

ADL500 the Ultimate Inverter for Elevator

Smart, flexible and
unique in safety

Industrial Motors
Commercial &
Appliance Motors
Automation
Digital &
Systems
Energy
Transmission &
Distribution
Coatings



Driving efficiency and sustainability





S U M M A R Y

Presentation

04

Segments

05

Guide to selection

05

Fields of application

06

Advanced safety functions

08

Smart connectivity

09

Simple to use

10

ADL500

12

Product overview

12

General characteristics

13

Input data

14

Output data

15

Dimensions and weights

17

Ordering codes

19

EBC500

24

Drive programming

26

The advantages of regeneration

27







ADL500 Lift Drives

Complete power range

ADL500 range extension

- 3 product lines
- 4 mechanical sizes
- 14 power sizes from 1.1 to 45 kW



	SIZE 1	SIZE 2	SIZE 3	SIZE 4
@400 Vac	4 / 5.5 / 7.5 kW	11 / 15 kW	18.5 / 22 kW	30 / 37 / 45 kW

In the last decade the elevators have been under a tremendous evolution from the technology standpoint like never before. Safety, comfort travel, efficiency, reliability, remote access combined with the use of smartphones and tablets are the major changes that we daily experience versus the old generation systems.

WEG has developed the new **ADL500 inverter series** specific for elevators EN 81-20 / EN 81-50 certified.

The series is composed of three lines ADL550, ADL530 and ADL510 designed to answer the requirements of high rise, medium rise and low rise buildings, without to forget the big market of the modernization.

ADL510

Designed to be simple and easy to install in case of **asynchronous motors** typical of low-rise buildings or modernization both in open and close loop.

ADL530

Designed to control both **geared and gearless** motors with integrated on-board **universal encoder interface** (EnDat, SinCos, BiSS, SSI and Digital Incremental) and built-in CAN port for communication by **CANopen 301** and **CANopen Lift DS417** are ready to use.

ADL550

In addition to ADL530 features, ADL550 integrates:



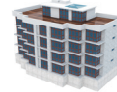
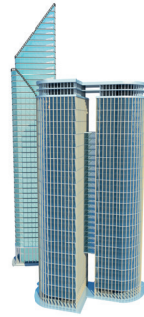

- **Advanced safety functions:** Safe Torque Off SIL3 (phase contactor-less), Safe Brake Test (SBT) to check the motor brakes effectiveness, and the Safe Brake Control SIL3 (SBC) that replaces the electro-mechanical brakes contactors by internal electronics with the accessory EBC500 (brake contactor-less).
- **Elevator positioning control** (EPC) that allows to have a better comfort with the direct approach and precise floor levelling even for very high demanding elevators.
- **Stand-by management**, to power supply only the regulation card of the drive to eliminate the energy consumption during the idle state.

Segments



	High rise	Mid rise	Low rise	Home lift
Profile	<ul style="list-style-type: none"> - Height: 90+ m - Floors: 30+ - Speed range: up to 5 m/s 	<ul style="list-style-type: none"> - Height: 18...90 m - Floors: 6...30 - Speed range: 0.8...2.5 m/s 	<ul style="list-style-type: none"> - Height: 12...18 m - Floors: 3...6 - Speed range: 0.6...0.8 m/s 	<ul style="list-style-type: none"> - Height: 4...8 m - Floors: 1...2 - Speed range: 0.3...0.6 m/s
Requirements	<ul style="list-style-type: none"> - High speed - Reliability - Smooth acceleration and ride comfort - Low noise - Limited passengers' waiting and travel time - Regenerative solution 	<ul style="list-style-type: none"> - Cost saving - Space saving - Low energy consumption - Smooth acceleration and ride comfort - Regenerative solution 		<ul style="list-style-type: none"> - Cost saving - Space saving (MRL) - Low energy consumption - Low noise - Easy commissioning - Single phase 230 V
Specific functions	<ul style="list-style-type: none"> - Advanced safety functions - Remote monitoring - Pre-torque and precise landing at floor - Contactor-less - Door pre-opening - AFE regenerative units 	<ul style="list-style-type: none"> - Optimized hardware solutions - Pre-torque and precise landing at floor - AFE regenerative units 		<ul style="list-style-type: none"> - Optimized hardware solutions - Contactor-less - External +24 Vdc power supply for stand-by control - Rapid commissioning

Guide to selection

	High rise	Mid rise	Low rise	Home lift
Regenerative	 <p>AFE200 + ADL500</p>			
Non regenerative	 <p>ADL550</p>	 <p>ADL530</p>	 <p>ADL510</p>	 <p>ADL550-2M</p>

Fields of application

Traffic profiles

Although an application may be defined initially in terms of floor number and car speed, the various traffic profiles are another essential factor for its better definition.

Buildings used for offices, apartments, businesses or public services require an adequate analysis of their traffic profile in order to choose the best system and all of its components.

The number of people, direction of movement, and specific time bands determine different traffic profiles, characterized by:

- People entering or leaving the loading lobby
- Inter-floor traffic
- Traffic on specific floors
- Peak hours
- Average car load

Each type of building will have different traffic profiles to be managed by the lift system.

Office buildings

These have two peak periods: up-peak in the morning and down-peak in the evening, with inter-floor traffic limited to specific floors (restaurants, car parks, and common areas).

The system must be designed to reduce waiting times for people entering the loading lobby in the morning, to efficiently receive calls from people leaving in the evening, and to manage full loads at peak hours. Homing functions are typically used, in which the car automatically goes to the floor in specific time bands. Functions such as door **pre-opening and express arrival** (available in the ADL500 family) **reduce waiting times and increase the traffic handled.**

Functions such as pre-torque increase comfort regardless of the number of people in the car.



Hotels

There is a peak in the morning to the restaurant floor for breakfast and to the exit, whereas incoming traffic has no specific peaks.

Inter-floor traffic mainly regards the hotel staff or specific floors (leisure, catering).

The entire system is improved by functions that reduce waiting times and that best manage full cars.

The ADL500 provides functions such as pre-torque and door pre-opening **to improve system performance.**

The integrated STO allows to avoid installations on contactors, **reducing the switching noise.**

Fields of application

Traffic profiles

Hospitals

Peak hours are during visiting hours (if concentrated in specific time bands). Hospitals have heavy inter-floor traffic due to patients moving from one ward to another and to movements of personnel. Hospitals can **greatly reduce energy costs by using regenerative solutions**, even in Low and Mid Rise applications. Regardless of height, comfort and landing speed are critical for handling emergencies and for moving people with physical limitations. Functions such as **precise landing at the floor and comfort** when running and starting/arriving are requirements that cannot be entrusted to general purpose drives. The ADL500, designed for civil lift applications, is the best answer. The 24h x 365 days **remote monitoring** open the possibility to the predictive maintenance reducing the down service.



Residential buildings

Residential buildings have no peak traffic hours, although traffic in the morning and in the evening is higher than the daily average. There is practically no inter-floor traffic. Because of the progressively aging population, system down-time must be reduced to an absolute minimum, and all components must be selected on the basis of quality and reliability. Thanks to the **stand-by management it is possible to save energy** limiting the power consumption to a few watts in not operative elevator time bands. The noise especially in the night can be dramatically reduced by the contactorless configuration.

Advanced safety functions

Since years WEG aims to increase more and more the **level of safety** of the inverters, helping the operators to reduce installation and maintenance costs avoiding the use of external components.

The ADL550 series integrates multiple safety features that are requested by the current standards **EN 81-20 / EN 81-50**.

UCM (Unintended Car Movement)

As reported in the paragraph 5.6.7 in the EN 81-20, it is requested the immediate stop of the car in case of movement with doors open. To answer this requirement, WEG introduced the continuous independent monitoring of the brakes feedback.

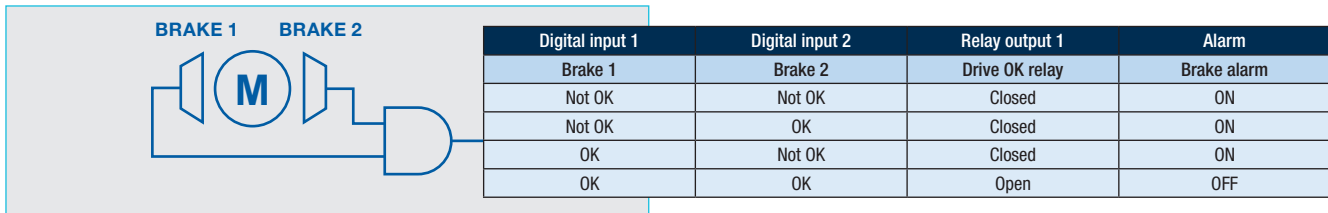

STO (Safe Torque Off) SIL3

Based on the paragraph 5.9.2.5 in the EN 81-20, in order to cut the motor power supply that cause the motor rotation it is requested to use two independent contactors that increase the cost of the installation and the noise of the switch. WEG integrated the STO-SIL3 certified safety circuit that allows to avoid the installation of external contactors between the motor and the inverter.

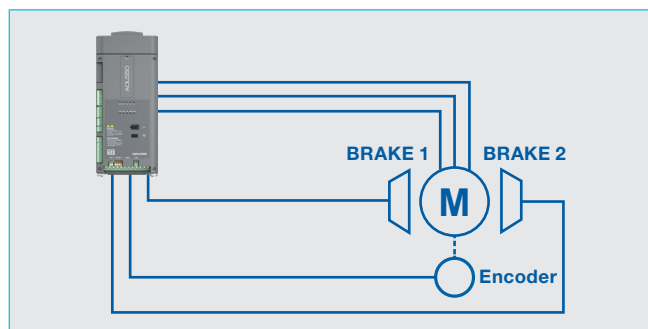
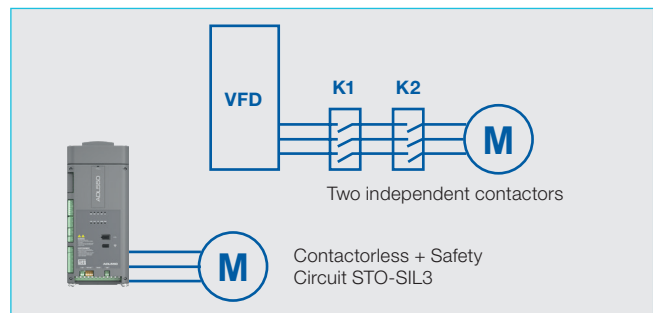

SBT (Safe Brake Test)

WEG has developed a specific function to test the holding torque of the motor brakes (operational or holding brake) in motor with encoder, both with the two brakes active or for each brake independently. If, during the test, the rotor moves beyond an acceptable range an alarm is raised.

EBC500 - Electronic Brake Control SIL3

The EBC500 (Electronic Brake Control) is an external optional module designed by WEG for the new inverter family ADL550, that enable the safe control and monitoring of the motor's brakes. The traditional electro-mechanical brakes contactors, subject to wear and failures are replaced by internal electronics featuring longest lifetime (zero contactors solution) reducing the maintenance cost and increasing the durability of the service life of the brakes.

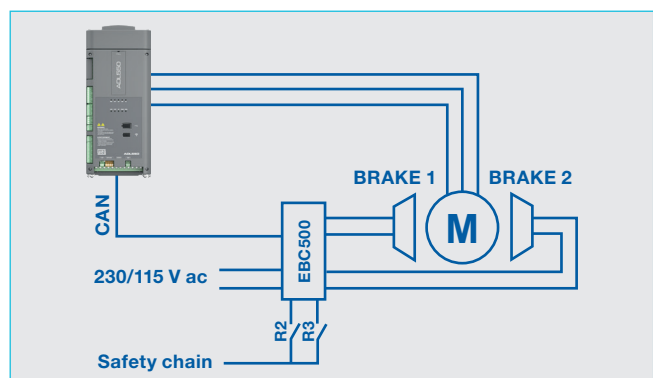

Smart Connectivity

Wi-Fi connection and cloud service: the new era of accessibility



The **ADL500 series** introduce operators in a new era of inverter management. Together with the traditional approach by plugged keypad or cabled PC, that oblige the operators to be on-site and close to the drive; WEG introduces a new generation of inverter management based on the modern telecommunication technology.

Thanks to WEG Liftouch, the app designed by WEG, operations like the startup, tuning, monitoring and the alarm check, can be easily achieved by mobile phone or tablet with a simple Wi-Fi connection, or can be fulfilled from remote, thanks to the WEG Portal, the cloud infrastructure that allows customers to create their own **Elevator Management System**.



WEG Liftouch App

- Direct Wi-Fi connection using Wi-Fi drive link optional module (1).
- Direct ETH connection or through LAN using the Modbus-TCP protocol (2).
- Remote connection with drive connected to a IoT gateway with SIM card and data connection. By logging onto the WEG Drives RMS portal, it is possible to monitor and manage the in-field drives and access them directly (3).

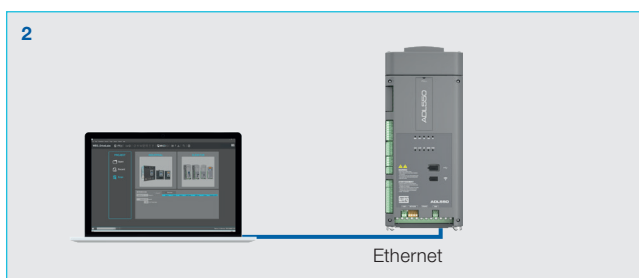

WEG Drivelabs configuration tool

- Direct ETH connection or through LAN using the Modbus-TCP protocol (2).
- Direct Wi-Fi connection using Wi-Fi DriveLink optional module (1).

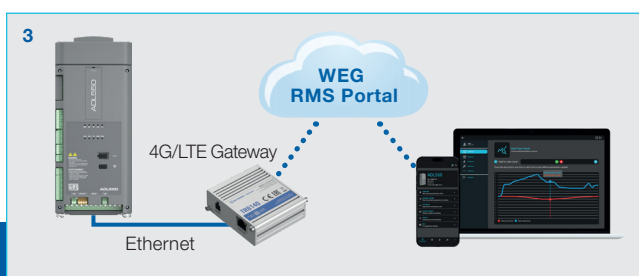

Simple to use

Following one of the famous statements of the greatest scientist Albert Einstein “Make things as simple as possible, but no simpler”, the ADL500 drive introduces many features to meet all user profiles and needs.

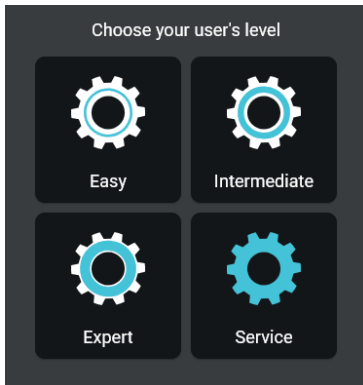

3 user levels

The ADL500 has 3 levels of users to meet every skill level. From **Easy** to **Intermediate** to **Expert** level it is possible to set the drive to give access in Read and Write mode to a selection of parameters based on user skill level. In addition, the access can be locked with customizable passwords to further secure the system giving access only to authorized users.

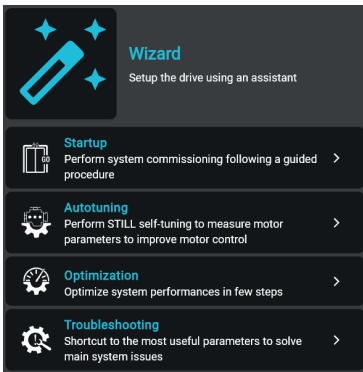

4 wizards

The ADL500 drive interface has been expanded with 4 multi-step guided procedures leading the user through a sequence of small steps for:

- **Drive set-up:** for drive setting at first power-on.
- **System Start-up:** for elevator commissioning.
- **Performance optimization:** to optimize control response in order to maximise cabin comfort.
- **Troubleshooting:** to have direct access to the parameters affected by specific elevator operating conditions.

Universal encoder

The ADL530 and ADL550 have an integrated HW interface to manage multiple encoders. Encoder configuration can be simply set via SW with a dedicated parameter and selection list including all the most common encoders used in elevator application (SinCos, EnDat, SSI, BiSS, Digital Incremental).

Integrated Universal encoder leads to multiple advantages from ordering codes reduction, no need to stock expansion cards for each encoder type and no effort to mount them on the drive.

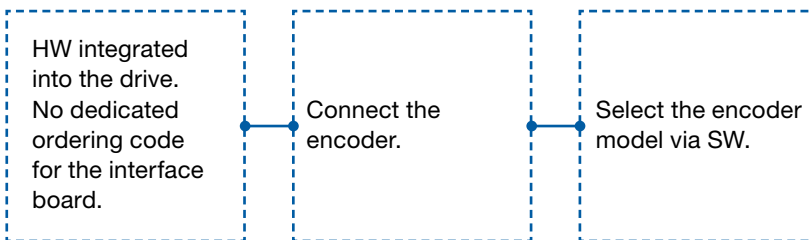

Universal encoder interface

- No need of additional cards to install and stock.
- Configuration via software.

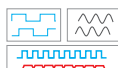

Emergency Complete Functions

In case of blackouts and emergency conditions ADL500 offer a wide range of features to meet user and application needs:

- -EMS version allow ADL500 to be powered directly with 48-96 Vdc battery bank.
- “Recommended direction” function allows the drive to automatically choose the best direction to return to the nearest floor reducing the energy consumption of the back-up power supply system.
- Wide choice of emergency manoeuvre even simplifying the wiring of the control panel to manage the various movements in emergency by reducing external circuits.

Periodic Safety Check

Special functions integrated into ADL500 allow to simply manage safety periodic tests such as:

- Elevator brakes monitoring and control.
- Elevator Ropes Slippage check without damaging them.



ADL500

Product overview

Optional programming keypad

The optional programming keypad with internal memory is easy to use and always ready

Expansion cards

- Plug-in boards for:
- additional I/Os (4DI + 2DO) or
 - serial communication integration

Easy to use

- 4 wizards
- Multiple user levels
- Simple configuration

Input/Output

	ADL500	ADL530	ADL510
Analog input	2	2	1
Digital input	8-1 enable	8-1 enable	8-1 enable
Digital output	4 (relays)	4 (relays)	4 (relays)
Fast digital input	2	-	-

Universal multi-encoder interface

Selects the encoder type without adding dedicated boards, such as: SinCos, EnDat, SSI, BiSS, Digital Incremental

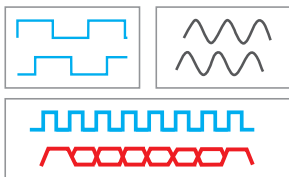

Safety functions

Safety features to prevent accidental motor start:

- SBT Safe Brake Test
- STO Contactorless SIL3 (Category PL_e)
- SBC Safe Brake Control SIL3 with EBC accessory



Green approach

- Regenerative configuration with the AFE200 external modules
- External +24 Vdc power supply for stand-by management
- Hybrid power supply with supercapacitors
- Regenerative energy calculation



USB port

- Uploading and downloading parameters file
- Fast upload of motor dataplate information from free database
- Uploading languages and SW applications on board the drive
- Smart FW update

Wi-Fi communication

Plug-in for optional Drive Link Wi-Fi module for wireless communication via WEG Liftouch APP and WEG DriveLabs



CANopen port

- CANopen 301
- CANopen customizable
- CANopen Lift DS417 with dedicated SW





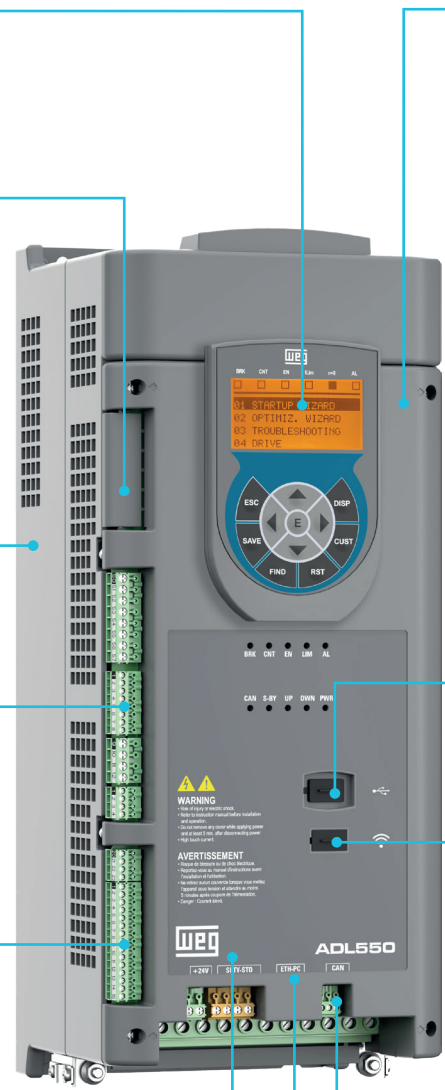

Ethernet port

Built-in Ethernet communication with Modbus-TCP protocol for direct/LAN connection to monitor and configure the drive or for remote gateway connection



ADL500

General characteristics

Model	ADL510	ADL530	ADL550
Control mode	SSC (Sensorless Scalar Control), Asyn FOC (Field Oriented Control)	SSC (Sensorless Scalar Control), Asyn / Syn FOC (Field Oriented Control)	
Motor type	Asynchronous	Asynchronous, synchronous	
Input voltage (output power)	- 4: 3 x 400 Vac	- 4: 3 x 230-400-480 Vac - 2T: 3 x 200-230 Vac	- 4: 3 x 230-400-480 Vac - 2T: 3 x 200-230 Vac - 2M: 1 x 200-230 Vac
Speed accuracy	±0.01% rated motor speed		
Analog inputs	1		
PTC input	-	Yes	
Digital outputs	4 (relay)		
Fast freeze inputs	-	2	
Overload	183% x 10s	183% x 10s	183% x 10s / 200% x 2s
+24 V dc external supply	-	Yes	
Regulation terminals	Removable		
IO extension	-	4DI + 2RO	
Max output frequency	300 Hz		
EMI filter	Integrated (in the ADL5x0-...-F version)		
Braking unit	Integrated		
USB port	-	Yes	
Wi-Fi module	-	Optional	Optional
Encoder	TTL/HTL	Universal multi-encoder card integrated (TTL/HTL/EnDat/BISS/SinCos/SSI)	
Emergency operation	Based on drive version: UPS (1x230 Vac), UPS or battery with aux PW supply (UB version), direct 48-96 Vdc battery supply (EMS version)		
Functions	<ul style="list-style-type: none"> - Wizards for: <ul style="list-style-type: none"> - Drive set-up - Startup - Optimization of comfort and performance - Troubleshooting - Management of built-in incremental digital encoder with repetition - Multi-speed control (EFC) - Calculation of energy savings in regenerative configuration - Extended emergency functions 	<ul style="list-style-type: none"> In addition to the functions of the 510: <ul style="list-style-type: none"> - Universal multi-encoder card integrated - Wireless control through WEG Liftouch APP - USB port for: <ul style="list-style-type: none"> - Import/export parameter file - FW download - Drive language selection - Setting motor data from DB - CANopen Lift 417 	<ul style="list-style-type: none"> In addition to the functions of the 530: <ul style="list-style-type: none"> - Safety functions - System stand-by management - Position Control - Direct Arrival (EPC)
Communication	Modbus-TCP (RJ45 port)		
Protection level	IP20		
Safety features	-	<ul style="list-style-type: none"> - Safe Torque Off SIL3 (Contactorless). - Safe Brake Test (SBT) - Safe Brake Control SIL3 (with EBC500 external module) 	
Operating temperature	Size 1/2/3	40 °C (without derating) 50 °C (with derating)	50 °C (without derating)
	Size 4	-	45 °C (without derating) 50 °C (with derating)
Altitude	Max 2,000 m (up to 1,000 m without derating)		
Marks	    Check for each individual product.		
Standards	Climatic conditions: EN 60721-3-3; Electrical safety: EN 61800-5-1, ASME17.5/CSA B44.1, UL840 pollution degree 2; EMC compatibility: EN 12015 (with integrated filter), EN 12016. Other elevator standards: EN 81-20, EN 81-50, EN 50581:2012.		

Notes

¹⁾ Compliant with CE directive on low-voltage equipment (LVD 2014/35/EU, EMC 2014/30/EU, Lift 2014/33/EU, RoHS 2011/65/EU, Reach (1907/2006).

Input data

ADL5XX - ... - 4, 3 ph		1040	1055	1075	2110	2150	3185	3220	4300	4370	4450	
U _{in} • AC input voltage	Vac	three-phase 230 - 400 - 480 Vac -15% +10%										
F _{in} • Input frequency	Hz	50/60 Hz, ±5%										
Connection to TT and TN networks		Yes, standard version										
Connection to IT networks		Yes, dedicated version available upon request ¹⁾										
Choke		Optional (DC or AC) on size 1, 2, 3. Integrated DC side choke on size 4.										
Overvoltage threshold	Vdc	820 Vdc										
Undervoltage threshold	Vdc	@ 480 Vac = 470 Vdc @ 460 Vac = 450 Vdc @ 400 Vac = 391 Vdc @ 230 Vac = 225 Vdc										
In • Effective input current (@ In out)												
	@ 230 Vac	A	12	17	23	31	42	50	55	55	72	89
	@ 400 Vac	A	11	16	22	29	40	47	53	55	72	89
	@ 480 Vac	A	10	15	20	26	37	45	50	49	65	81
No-load consumption (energy rating):												
	Ready (no-load) ²⁾ consumption "Fan Off"	W	20	20	20	20	20	20	20	32	32	32
	Fan consumption	W	8	10	10	10	16	16	16	21	32	32
	Ready (no-load) ²⁾ consumption "Fan On"	W	28	30	30	30	36	36	36	53	64	64

ADL5XX - ... - 2T, 3 ph		2055	2075	3110	4150	4185	4220	
U _{in} • AC input voltage	Vac	three-phase 200 - 230 Vac ±10%						
F _{in} • Input frequency	Hz	50/60 Hz, ±2%						
Connection to TT and TN networks		Yes, standard version						
Connection to IT networks		Yes, dedicated version available upon request ¹⁾						
Choke		Optional (DC or AC) on size 1, 2, 3. Integrated DC side choke on size 4.						
Overvoltage threshold	Vdc	500 Vdc						
Undervoltage threshold	Vdc	@ 200 Vac = 196 Vdc @ 230 Vac = 225 Vdc						
In • Effective input current (@ In out)								
	@ 230 Vac	A	31	42	55	55	72	89
No-load consumption (energy rating):								
	Ready (no-load) ²⁾ consumption "Fan Off"	W	20	20	20	25	25	25
	Fan consumption	W	8	16	16	25	36	36
	Ready (no-load) ²⁾ consumption "Fan On"	W	28	36	36	45	56	56

ADL5XX - ... - 2M, 1 ph		1011	1015	2022	2030	3040	3055	
U _{in} • AC input voltage	Vac	single-phase 200 Vac -10% +10% single-phase 230 Vac -15% +10%						
F _{in} • Input frequency	Hz	50/60 Hz, ±2%						
Connection to TT and TN networks		Yes, standard version						
Connection to IT networks		Yes, dedicated version available upon request ¹⁾						
Overvoltage threshold	Vdc	410 Vdc						
Undervoltage threshold	Vdc	@ 200 Vac = 196 Vdc @ 230 Vac = 225 Vdc						
In • Effective input current (@ In out)								
	@ 230 Vac	A	16	18	24	31	35	50
No-load consumption (energy rating):								
	Ready (no-load) ²⁾ consumption "Fan Off"	W	20	20	20	32	32	32
	Fan consumption	W	10	10	10	21	32	32
	Ready (no-load) ²⁾ consumption "Fan On"	W	30	30	30	53	64	64

Notes

- ¹⁾ ADL500 can only operate on IT networks devoid of any faults (between active parts and PE) or in the presence of temporary faults. Therefore an insulation monitor MUST be used to detect and enable prompt removal of any fault condition.
- ²⁾ Power consumption when drive is powered from the three-phase mains and is ready to start.

Output data

ADL5XX - ... - 4, 3 ph												
Sizes		1040	1055	1075	2110	2150	3185	3220	4300	4370	4450	
In • Rated output current (fsw = default)												
@ Uln = 230 Vac	A	9	13.5	18.5	24.5	32	39	45	60	75	90	
@ Uln = 400 Vac	A	9	13.5	18.5	24.5	32	39	45	60	75	90	
@ Uln = 460 Vac	A	8.1	12.2	16.7	22	28.8	35.1	40.5	54	67.5	81	
Pn mot (recommended motor power, fsw = default)												
@ Uln = 230 Vac	kW	2	3	4	5.5	7.5	9	11	15	18.5	22	
@ Uln = 400 Vac	kW	4	5.5	7.5	11	15	18.5	22	30	37	45	
@ Uln = 460 Vac	HP	5	7.5	10	15	20	25	30	40	50	60	
Reduction factor												
Kt ADL550 ¹⁾		1	1	1	1	1	1	1	0.95	0.95	0.95	
Kt ADL510-530 ²⁾		0.90	0.90	0.90	0.90	0.90	0.90	0.90	0.95	0.95	0.95	
Kalt ³⁾		1.2	1.2	1.2	1.2	1.2	1.2	1.2	1.2	1.2	1.2	
Overload												
ADL510, ADL530: 183% x 10s ADL550: 183% x 10s/200% x 2s												
Maximum switching frequency	kHz	10										
U2 • Maximum output voltage		0.98 x Uln (Uln = AC input voltage)										
f2 • Maximum output frequency	Hz	300										
IGBT braking unit		Standard internal (requires external resistor); braking torque 150% MAX										

ADL5XX - ... - 2T, 3 ph								
Sizes		2055	2075	3110	4150	4185	4220	
In • Rated output current (fsw = default)								
@ Uln = 200 - 230 Vac	A	24.5	32	45	60	75	90	
Pn mot (recommended motor power, fsw = default)								
@ Uln = 200 - 230 Vac	kW	5.5	7.5	11	15	18.5	22	
@ Uln = 200 - 230 Vac	HP	7.5	10	15	20	25	30	
Reduction factor								
Kt ADL550 ¹⁾		1	1	1	0.95	0.95	0.95	
Kt ADL510-530 ¹⁾		0.90	0.90	0.90	0.95	0.95	0.95	
Kalt ³⁾		1.2	1.2	1.2	1.2	1.2	1.2	
Overload								
ADL510, ADL530: 183% x 10s ADL550: 183% x 10s/200% x 2s								
Maximum switching frequency	kHz	10						
U2 • Maximum output voltage		0.98 x Uln (Uln = AC input voltage)						
f2 • Maximum output frequency	Hz	300						
IGBT braking unit		Standard internal (requires external resistor); braking torque 150% MAX						

ADL5XX - ... - 2M, 1 ph							
Sizes		1011	1015	2022	2030	3040	3055
In • Rated output current (fsw = default)							
@ Uln = 200 - 230 Vac	A	6	6.8	9.6	13	15	22
Pn mot (recommended motor power, fsw = default)							
@ Uln = 200 - 230 Vac	kW	1.1	1.5	2.2	3	4	5.5
Reduction factor							
Kt ADL550 ¹⁾		1	1	1	1	1	1
Kalt ³⁾		1.2	1.2	1.2	1.2	1.2	1.2
Overload							
ADL550: 183% x 10s/200% x 2s							
Maximum switching frequency	kHz	10					
U2 • Maximum output voltage		0.98 x Uln (Uln = AC input voltage)					
f2 • Maximum output frequency	Hz	300					
IGBT braking unit		Standard internal (requires external resistor); braking torque 150% MAX					

Notes:

¹⁾ Kt (ADL550 size 1, 2, 3): no derating.

Kt (ADL510, ADL530 size 1,2,3): derating factor for ambient temperature of 50 °C (1% every °C above 40 °C).

Kt (ADL530, ADL550 size 4): derating factor for ambient temperature of 50 °C (1% every °C above 45 °C).

³⁾ Kalt: derating factor for installation at altitudes above 1,000 meters a.s.l. Value to be applied = 1.2% each 100 m increase above 1,000 m.

E.g.: altitude 2,000 m, Kalt = 1.2% x 10 = 12% derating; In derated = (100 - 12) % = 88 % In.

Derating values in overload condition

In overload conditions the output current DO NOT depends on the output frequency, as shown in the figure below.

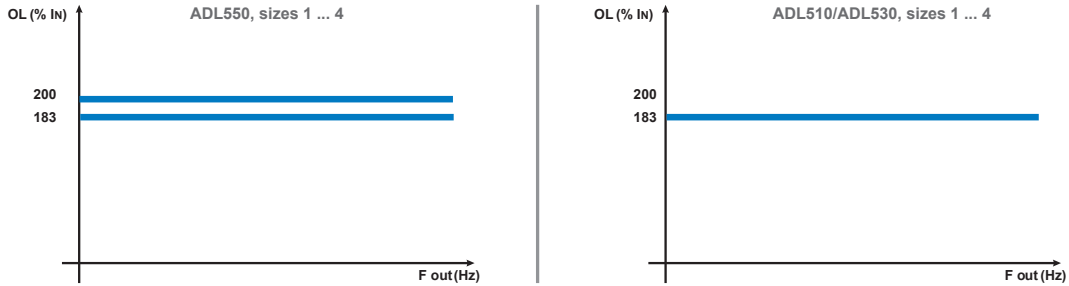

Derating values for switching frequency

The switching frequency is modified according to the temperature of the drive (measured on the heat sink), as shown in the figure below.

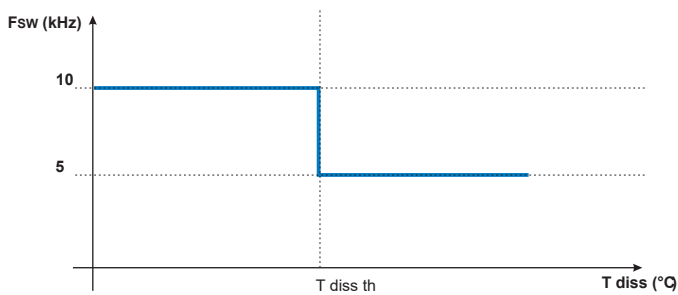

Ambient temperature reduction factor

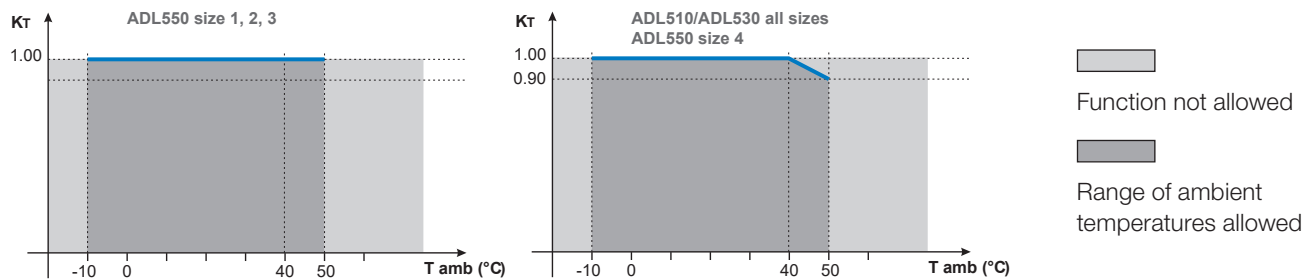

Dimensions and weights

Size 1

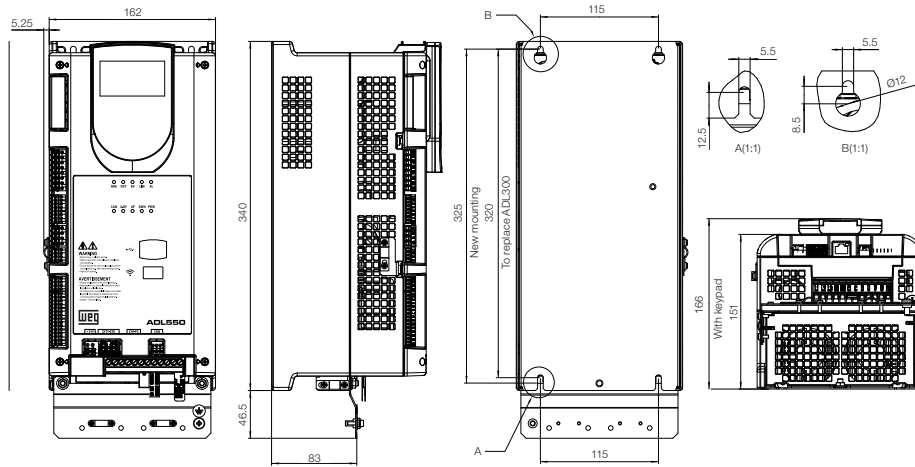

Sizes	Dimensions: Width x Height x Depth ¹⁾		Weight	
	mm	inches	kg	lbs
ADL510/530/550-1...	162 x 340 x 151	6.38 x 13.38 x 5.9	5.5	12.1

Size 2

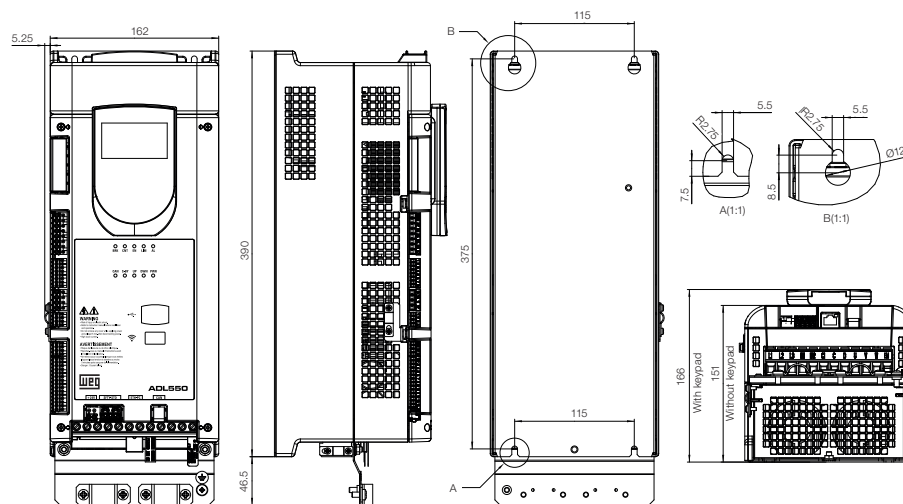

Sizes	Dimensions: Width x Height x Depth ¹⁾		Weight	
	mm	inches	kg	lbs
ADL510/530/550-2...	162 x 390 x 151	6.38 x 15.35 x 5.94	7.0	15.4

Note:

¹⁾ Without optional power shield (KIT-POWER-SHIELD).

Size 3

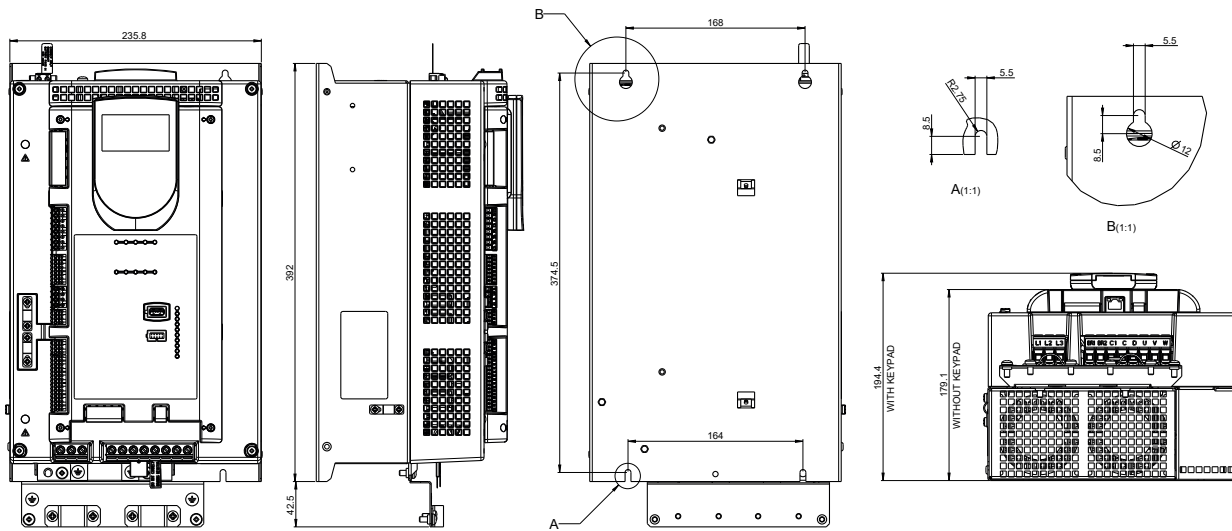

Sizes	Dimensions: Width x Height x Depth ¹⁾		Weight	
	mm	inches	kg	lbs
ADL510/530/550-3...	235.8 x 392 x 179.1	9.28 x 14.5 x 7	10.0	22.05

Size 4

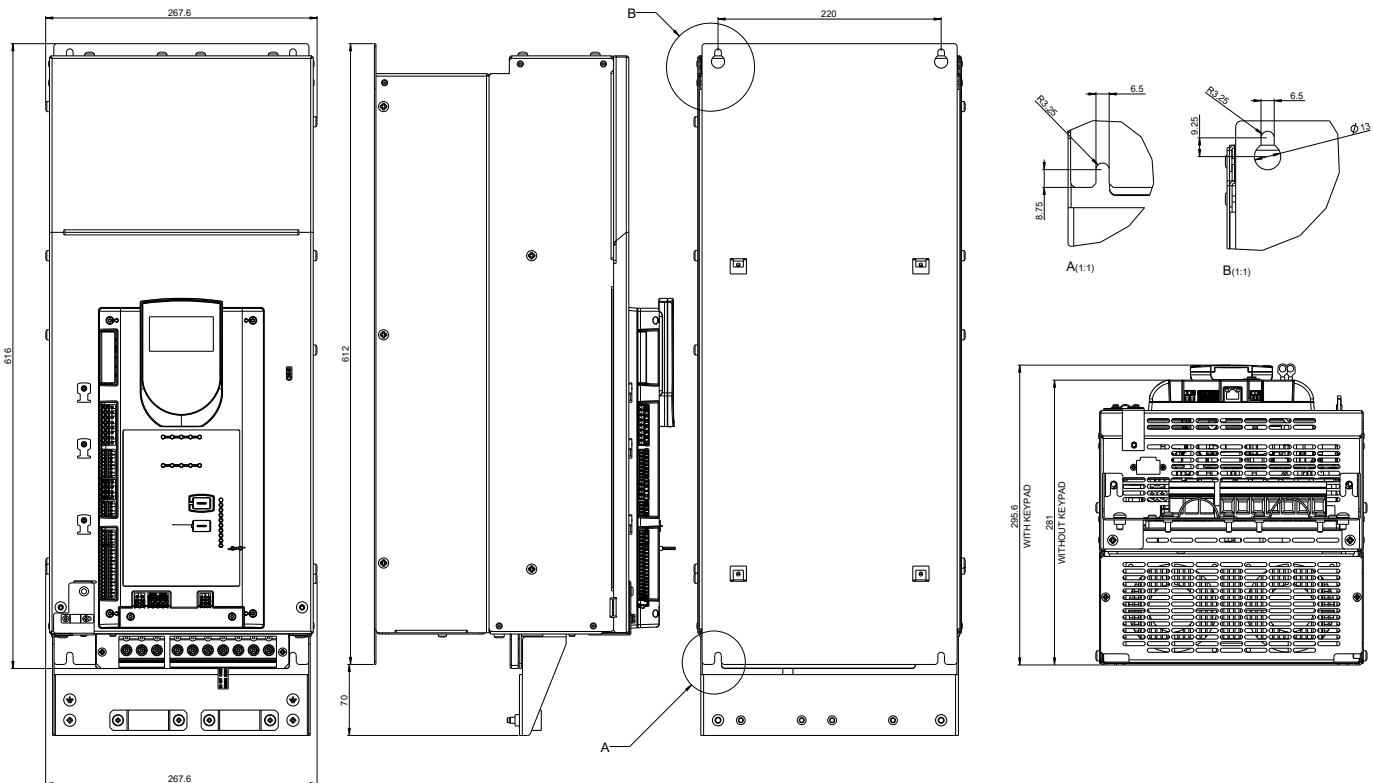

Sizes	Dimensions: Width x Height x Depth ¹⁾		Weight	
	mm	inches	kg	lbs
ADL510/530/550-4...	268 x 615 x 281	15.6 x 24.2 x 11	32	70.6

Note:
¹⁾ Without optional power shield (KIT-POWER-SHIELD).

Ordering codes

Product identification

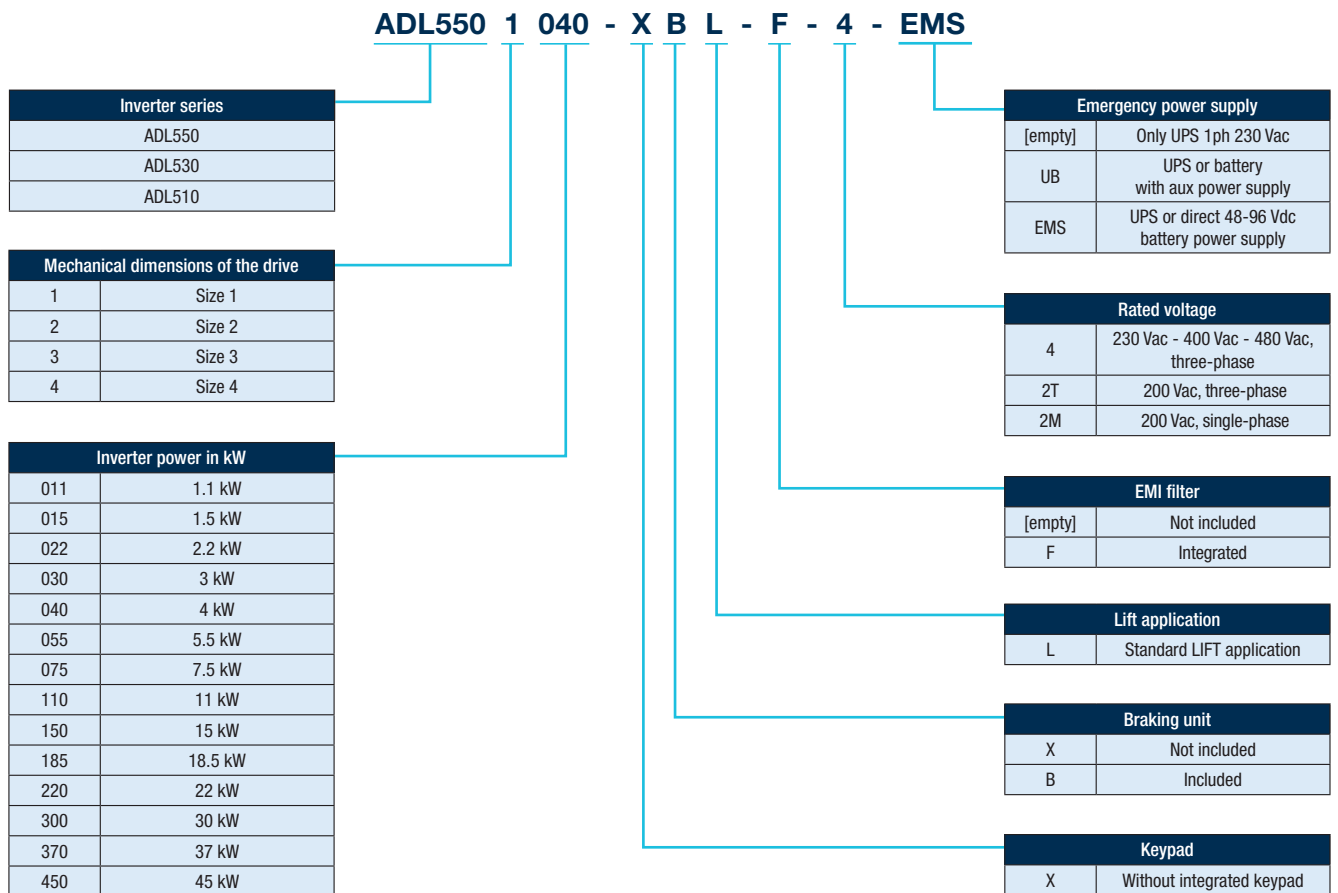

ADL510 | -4 | 400 Vac | Three-phase

Feedback for Incremental Digital + Sinusoidal Encoder

Code	Type	Pn at 400 Vac	Configuration
S9DL5101	ADL510-1040-XBL-4	4 kW	Integrated braking module - External EMC filter
S9DL5102	ADL510-1055-XBL-4	5.5 kW	Integrated braking module - External EMC filter
S9DL5103	ADL510-1075-XBL-4	7.5 kW	Integrated braking module - External EMC filter
S9DL5104	ADL510-2110-XBL-4	11 kW	Integrated braking module - External EMC filter
S9DL5105	ADL510-2150-XBL-4	15 kW	Integrated braking module - External EMC filter
S9DL5116	ADL510-3185-XBL-4-UB	18,5 kW	Integrated braking module - External EMC filter
S9DL5117	ADL510-3220-XBL-4-UB	22 kW	Integrated braking module - External EMC filter
S9DL5121	ADL510-1040-XBL-F-4	4 kW	Integrated braking module - Integrated EMC filter
S9DL5122	ADL510-1055-XBL-F-4	5.5 kW	Integrated braking module - Integrated EMC filter
S9DL5123	ADL510-1075-XBL-F-4	7.5 kW	Integrated braking module - Integrated EMC filter
S9DL5124	ADL510-2110-XBL-F-4	11 kW	Integrated braking module - Integrated EMC filter
S9DL5125	ADL510-2150-XBL-F-4	15 kW	Integrated braking module - Integrated EMC filter
S9DL5136	ADL510-3185-XBL-F-4-UB	18,5 kW	Integrated braking module - Integrated EMC filter
S9DL5137	ADL510-3220-XBL-F-4-UB	22 kW	Integrated braking module - Integrated EMC filter
S9DL5141	ADL510-1040-XBL-4-EMS	4 kW	Integrated braking module - External EMC filter - Integrated EMS module
S9DL5142	ADL510-1055-XBL-4-EMS	5.5 kW	Integrated braking module - External EMC filter - Integrated EMS module
S9DL5143	ADL510-1075-XBL-4-EMS	7.5 kW	Integrated braking module - External EMC filter - Integrated EMS module
S9DL5144	ADL510-2110-XBL-4-EMS	11 kW	Integrated braking module - External EMC filter - Integrated EMS module
S9DL5145	ADL510-2150-XBL-4-EMS	15 kW	Integrated braking module - External EMC filter - Integrated EMS module
S9DL5161	ADL510-1040-XBL-F-4-EMS	4 kW	Integrated braking module - Integrated EMC filter - Integrated EMS module
S9DL5162	ADL510-1055-XBL-F-4-EMS	5.5 kW	Integrated braking module - Integrated EMC filter - Integrated EMS module
S9DL5163	ADL510-1075-XBL-F-4-EMS	7.5 kW	Integrated braking module - Integrated EMC filter - Integrated EMS module
S9DL5164	ADL510-2110-XBL-F-4-EMS	11 kW	Integrated braking module - Integrated EMC filter - Integrated EMS module
S9DL5165	ADL510-2150-XBL-F-4-EMS	15 kW	Integrated braking module - Integrated EMC filter - Integrated EMS module

Ordering codes

ADL530 | -2T | 200-230 Vac | Three-phase

Feedback for multi encoder

Code	Type	Pn at 400 Vac	Configuration
S9DLT5302	ADL530-2055-XBL-2T	5.5 kW	Integrated braking module - External EMC filter
S9DLT5303	ADL530-2075-XBL-2T	7.5 kW	Integrated braking module - External EMC filter
S9DLT5314	ADL530-3110-XBL-2T-UB	11 kW	Integrated braking module - External EMC filter
S9DLT5315	ADL530-4150-XBL-2T-UB	15 kW	Integrated braking module - External EMC filter
S9DLT5316	ADL530-4185-XBL-2T-UB	18,5 kW	Integrated braking module - External EMC filter
S9DLT5317	ADL530-4220-XBL-2T-UB	22 kW	Integrated braking module - External EMC filter
S9DLT5322	ADL530-2055-XBL-F-2T	5.5 kW	Integrated braking module - Integrated EMC filter
S9DLT5323	ADL530-2075-XBL-F-2T	7.5 kW	Integrated braking module - Integrated EMC filter
S9DLT5334	ADL530-3110-XBL-F-2T-UB	11 kW	Integrated braking module - Integrated EMC filter
S9DLT5335	ADL530-4150-XBL-F-2T-UB	15 kW	Integrated braking module - Integrated EMC filter
S9DLT5336	ADL530-4185-XBL-F-2T-UB	18,5 kW	Integrated braking module - Integrated EMC filter
S9DLT5337	ADL530-4220-XBL-F-2T-UB	22 kW	Integrated braking module - Integrated EMC filter
S9DLT5342	ADL530-2055-XBL-2T-EMS	5.5 kW	Integrated braking module - External EMC filter - Integrated EMS module
S9DLT5343	ADL530-2075-XBL-2T-EMS	7.5 kW	Integrated braking module - External EMC filter - Integrated EMS module
S9DLT5362	ADL530-2055-XBL-F-2T-EMS	5.5 kW	Integrated braking module - Integrated EMC filter - Integrated EMS module
S9DLT5363	ADL530-2075-XBL-F-2T-EMS	7.5 kW	Integrated braking module - Integrated EMC filter - Integrated EMS module

ADL550 | -2T | 200-230 Vac | Three-phase

Feedback for multi encoder

Code	Type	Pn at 400 Vac	Configuration
S9DLT5502	ADL550-2055-XBL-2T	5.5 kW	Integrated braking module - External EMC filter
S9DLT5503	ADL550-2075-XBL-2T	7.5 kW	Integrated braking module - External EMC filter
S9DLT5514	ADL550-3110-XBL-2T-UB	11 kW	Integrated braking module - External EMC filter
S9DLT5515	ADL550-4150-XBL-2T-UB	15 kW	Integrated braking module - External EMC filter
S9DLT5516	ADL550-4185-XBL-2T-UB	18,5 kW	Integrated braking module - External EMC filter
S9DLT5517	ADL550-4220-XBL-2T-UB	22 kW	Integrated braking module - External EMC filter
S9DLT5522	ADL550-2055-XBL-F-2T	5.5 kW	Integrated braking module - Integrated EMC filter
S9DLT5523	ADL550-2075-XBL-F-2T	7.5 kW	Integrated braking module - Integrated EMC filter
S9DLT5534	ADL550-3110-XBL-F-2T-UB	11 kW	Integrated braking module - Integrated EMC filter
S9DLT5535	ADL550-4150-XBL-F-2T-UB	15 kW	Integrated braking module - Integrated EMC filter
S9DLT5536	ADL550-4185-XBL-F-2T-UB	18,5 kW	Integrated braking module - Integrated EMC filter
S9DLT5537	ADL550-4220-XBL-F-2T-UB	22 kW	Integrated braking module - Integrated EMC filter
S9DLT5542	ADL550-2055-XBL-2T-EMS	5.5 kW	Integrated braking module - External EMC filter - Integrated EMS module
S9DLT5543	ADL550-2075-XBL-2T-EMS	7.5 kW	Integrated braking module - External EMC filter - Integrated EMS module
S9DLT5562	ADL550-2055-XBL-F-2T-EMS	5.5 kW	Integrated braking module - Integrated EMC filter - Integrated EMS module
S9DLT5563	ADL550-2075-XBL-F-2T-EMS	7.5 kW	Integrated braking module - Integrated EMC filter - Integrated EMS module

ADL550 | -2M | 200-230 Vac | Single phase

Feedback for multi encoder

Code	Type	Pn at 400 Vac	Configuration
S9DLM5501	ADL550-1011-XBL-2M	1.1 kW	Integrated braking module - External EMC filter
S9DLM5502	ADL550-1015-XBL-2M	1.5 kW	Integrated braking module - External EMC filter
S9DLM5503	ADL550-2022-XBL-2M	2.2 kW	Integrated braking module - External EMC filter
S9DLM5504	ADL550-2030-XBL-2M	3 kW	Integrated braking module - External EMC filter
S9DLM5515	ADL550-3040-XBL-2M-UB	4 kW	Integrated braking module - External EMC filter
S9DLM5516	ADL550-3055-XBL-2M-UB	5.5 kW	Integrated braking module - External EMC filter
S9DLM5541	ADL550-1011-XBL-2M-EMS	1.1 kW	Integrated braking module - External EMC filter - Integrated EMS module
S9DLM5542	ADL550-1015-XBL-2M-EMS	1.5 kW	Integrated braking module - External EMC filter - Integrated EMS module
S9DLM5543	ADL550-2022-XBL-2M-EMS	2.2 kW	Integrated braking module - External EMC filter - Integrated EMS module
S9DLM5544	ADL550-2030-XBL-2M-EMS	3 kW	Integrated braking module - External EMC filter - Integrated EMS module

Options' ordering codes

DC/AC input chokes

DC input choke | ADL510/530/550 | -4 |

Code	Type	1040	1055	1075	2110	2150	3185	3220	4300...4450
S7AI10	LDC-004	•							
S7AI11	LDC-005		•						
S7AI12	LDC-007			•					
S7AI13	LDC-011				•				
S7AI14	LDC-015					•			
S7AI15	LDC-022						•	•	
Internal choke									•

DC input choke | ADL530/550 | -2T |

Code	Type	2055	2075	3110	4150	4185	4220
S7AI13	LDC-011	•					
S7AI14	LDC-015		•				
S7AI15	LDC-022			•			
Internal choke					•		
						•	
							•

AC input choke | ADL510/530/550 | -4 |

Code	Type	1040	1055	1075	2110	2150	3185	3220	4300	4370	4450
S7AAG	LR3y-2040	•									
S7AB5	LR3y-2055		•								
S7AB6	LR3y-2075			•							
S7AB7	LR3y-3110				•						
S7AB8	LR3y-3150					•	•				
S7FF4	LR3-022							•	•		
S7FF2	LR3-037									•	•

AC input choke | ADL530/550 | -2T |

Code	Type	2055	2075	3110	4150	4185	4220
S7AB6	LR3y-2075	•					
S7AB7	LR3y-3110		•				
S7AB8	LR3y-3150			•	•		
S7FF4	LR3-022					•	
S7FF2	LR3-037						•

AC output chokes

AC output choke | ADL510/530/550 | -4 |

Code	Type	1040	1055	1075	2110	2150	3185	3220	4300	4370	4450
S7FG3	LU3-005	•	•	•							
S7FG4	LU3-011				•						
S7FH2	LU3-015					•	•				
S7FH3	LU3-022							•			
S7FH4	LU3-030								•	•	
S7FH5	LU3-037										•

AC output choke | ADL530/550 | -2T |

Code	Type	2055	2075	3110	4150	4185	4220
S7FG4	LU3-011	•	•				
S7FH2	LU3-015			•			
S7FH3	LU3-022				•		
S7FH4	LU3-030					•	
S7FH5	LU3-037						•

Options' ordering codes

External braking resistors

Low & Mid Demand Systems | ADL510/530/550 | -4 |

Code	Type	1040	1055	1075	2110	2150	3185	3220	4300	4370	4450
S8SZ7	BRK RES EC 1K5 68R T	•	•								
S8SZ8	BRK RES EC 1K5 49R T			•							
S8SZ9	BRK RES EC 2K 28R T				•	•					
S8SZ18	BRK RES EC 4K 15R T						•	•			
S8T00H	BRT4K0-11R6								•	•	
S8T00I	BRT8K0-7R7										•

Low & Mid Demand Systems | ADL530/550 | -2T |

Code	Type	2055	2075	3110	4150	4185	4220
S8SZ16	BRK RES EC 2K 18R T	•	•				
S8SZ19	BRK RES EC 4K 12R T			•			
S8T00H	BRT4K0-11R6				•	•	
S8T00I	BRT8K0-7R7						•

Low & Mid Demand Systems | ADL550 | -2M |

Code	Type	1011	1015	2022	2030	3040	3055
S8SZ7	BRK RES EC 1K5 68R T	•	•				
S8SZ8	BRK RES EC 1K5 49R T			•			
S8SZ9	BRK RES EC 2K 28R T				•		
S8SZ18	BRK RES EC 4K 15R T					•	•

High Demand Systems | ADL510/530/550 | -4 |

Code	Type	1040	1055	1075	2110	2150	3185	3220	4300	4370	4450
S8SZ10	BRK RES EC 3K 68R T	•	•								
S8SZ11	BRK RES EC 4K 49R T			•							
S8SZ12	BRK RES EC 5K 28R T				•						
S8SZ13	BRK RES EC 8K 28R T					•					
S8SZ21	BRK RES EC 12K 15R T						•	•			
S799974	BDRT 16K1 10R								•	•	
S799962	BDR 24K1 7R5										•

High Demand Systems | ADL530/550 | -2T |

Code	Type	2055	2075	3110	4150	4185	4220
S8SZ17	BRK RES EC 4K 18R T	•	•				
S8SZ20	BRK RES EC 6K 12R T			•			
S8SZ18	BRK RES EC 4K 15R T				• (x 2)	• (x 2)	
S8T00H	BRT 4K0-11R6						• (x 2)

Various

Code	Type	Description
S5DL408	EXP-I01-ADL500	I/O expansion (4 digital inputs + 2 relays)
S52969WF	Wi-Fi Drive Link	Wi-Fi plug-in module
S5P11T	KB-ADL500	Programming keypad
S5P11TK1	KIT REMOTE KB-ADL500 5MT	RJ45 keypad remoting kit, L = 5 m
S5P11TK2	KIT REMOTE KB-ADL500 10MT	RJ45 keypad remoting kit, L = 10 m
S72684S12	KIT-POWER-SHIELD S1	Power cable shielding kit for size 1
S72684S13	KIT-POWER-SHIELD S2	Power cable shielding kit for size 2
S730143	KIT-POWER-SHIELD S3	Power cable shielding kit for size 3
S72902	KIT-POWER-SHIELD S4	Power cable shielding kit for size 4
S9DLEBC01	EBC500	Electronic Brake Control Module

EBC500

Electronic Brake Control

The EBC500 module is an electronic device for the excitation and control of the brakes elements with the ability to communicate and synchronize with the ADL550 series drives.

The Electronic Brake Module simplifies the brake control system by eliminating rectifiers and contactors while maintaining the highest level of safety and improving the efficiency and overall maintenance of the brake system.

The EBC500 manages the uncontrolled car movements requirements according to EN 81-20/50 and new revamping requirements UNI 10411-1.

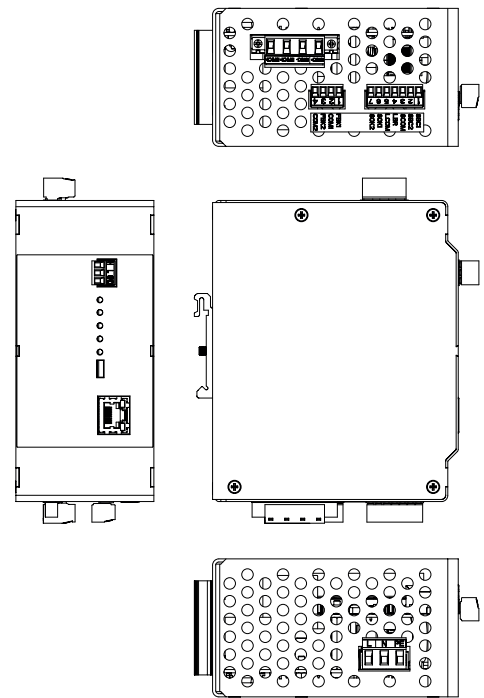

DIMENSIONS (WxHxD)		WEIGHT	
mm	inches	kg	lbs
66x144x116	2,59x5,66x4,56	0,680	1,5

Main Features:

- Up to 2 brake circuits from 105 to 207 Vdc
- Output current: 2 x 3.4 Arms
- Input voltage: 110-220 Vac @50/60Hz
- Controlled via CAN
- Safe Brake Control SIL 3 Certified

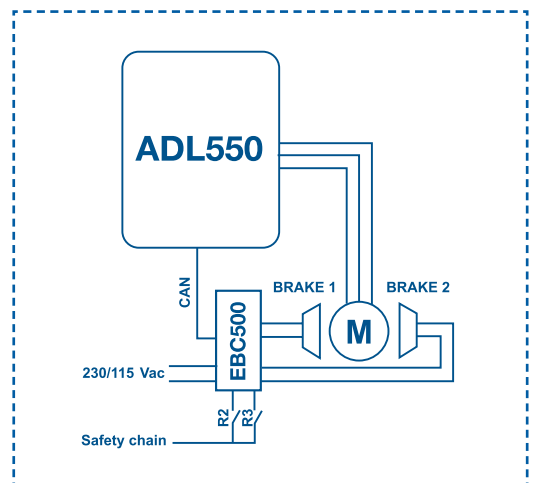

ZERO CONTACTORS

Integrated Safety circuit STO SIL 3
+ Safe Brake Control SIL 3

Advantages



COMMISSIONING

Traditional

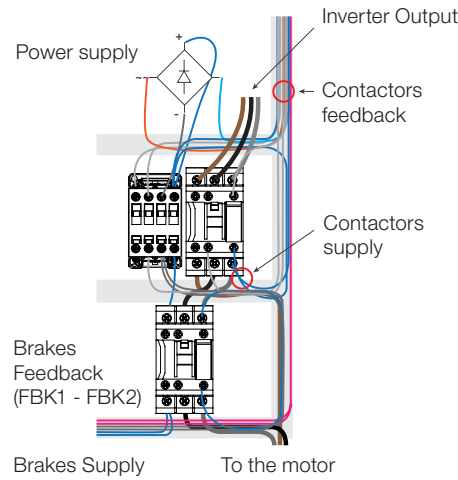

EBC500 + STO

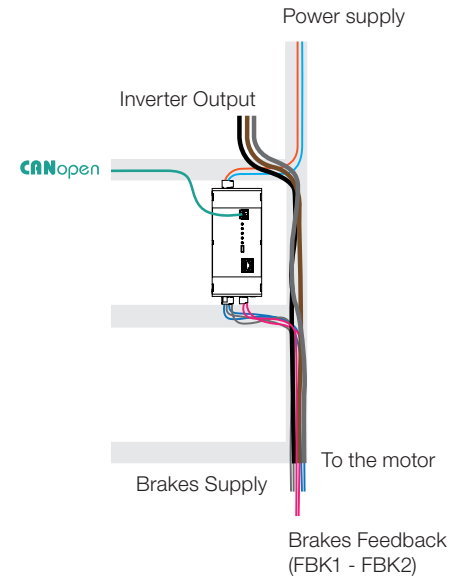

- Comparison with traditional approach
- Less cables and devices
- Less time for installation



ENERGY SAVING

- Adjustable output voltage and current
- Reduced holding voltage for lowest energy consumption

Traditional

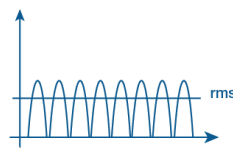

EBC500

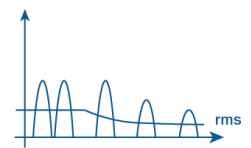

MAINTENANCE

- No need to periodically check cabling and connections
- No limitation coming from contactors durability



TROUBLESHOOTING

- Mean Time Between Failures (MTBF) increase
- Reduced EMC noise
- Less devices and cabling



SAFETY

- Faults elevator stop improved in terms of safety
- Brakes continuous monitoring
- Brakes control in line with EN81-20/50, SIL 3



COST SAVING

- All the above advantages leads to a cost reduction in both first investment and system life cycle

Drive programming

WEG Liftouch App



Fully responsive App, compatible with smartphones, tablets and PCs, and with any operating system.

Ease to use

Always keep track of the drive status, but with the intuitiveness of a common mobile app.

Available for Android, IOS, Windows.



Connect easily your mobile to your ADL500

In less than one minute

1
Plug Wi-Fi Drive Link Module on ADL500 or ADL550.

2
Open the App and follow the step by step connection procedure or select one of the preferred connections.

3
Select your access level and insert your password.

WEG DriveLabs Configurator

Enhancement of WEG PC configurator features in the same “family feeling” programming.

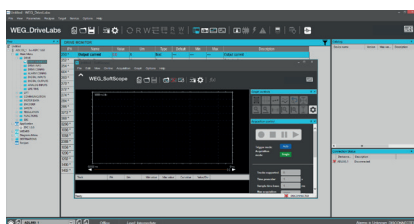
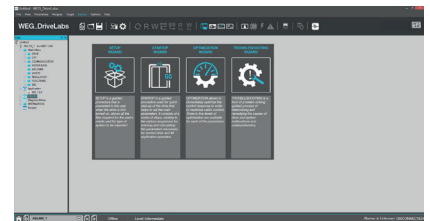
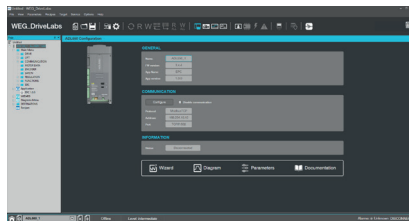
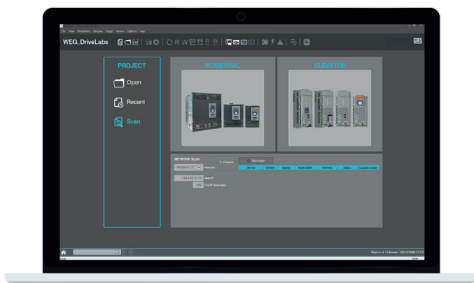

- Drive selection and scan
- Offline mode
- 4 wizards
- Function diagrams
- Digital oscilloscope

The advantages of regeneration

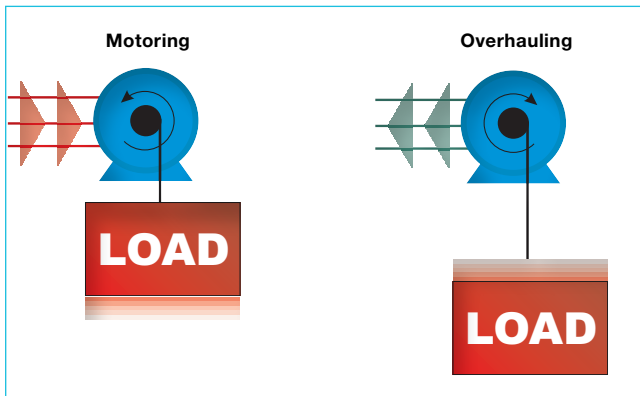

Lower operating costs

Regenerative units in lift systems provide significant benefits in terms of Building Automation and Energy Efficiency. Where justified by traffic profiles, a system with regenerative units provides both economic and technical advantages. The operating principle is simple: when the empty car goes up or the full car goes down, the mechanical system generates potential energy that the electric motor, “pulled” by the car load, converts into electrical energy.

Clean energy

The regenerative unit transforms the electrical energy generated by the motor into clean energy, namely with reduced harmonic distortion (THD <4%), making it reusable by other electrical equipment in the building.

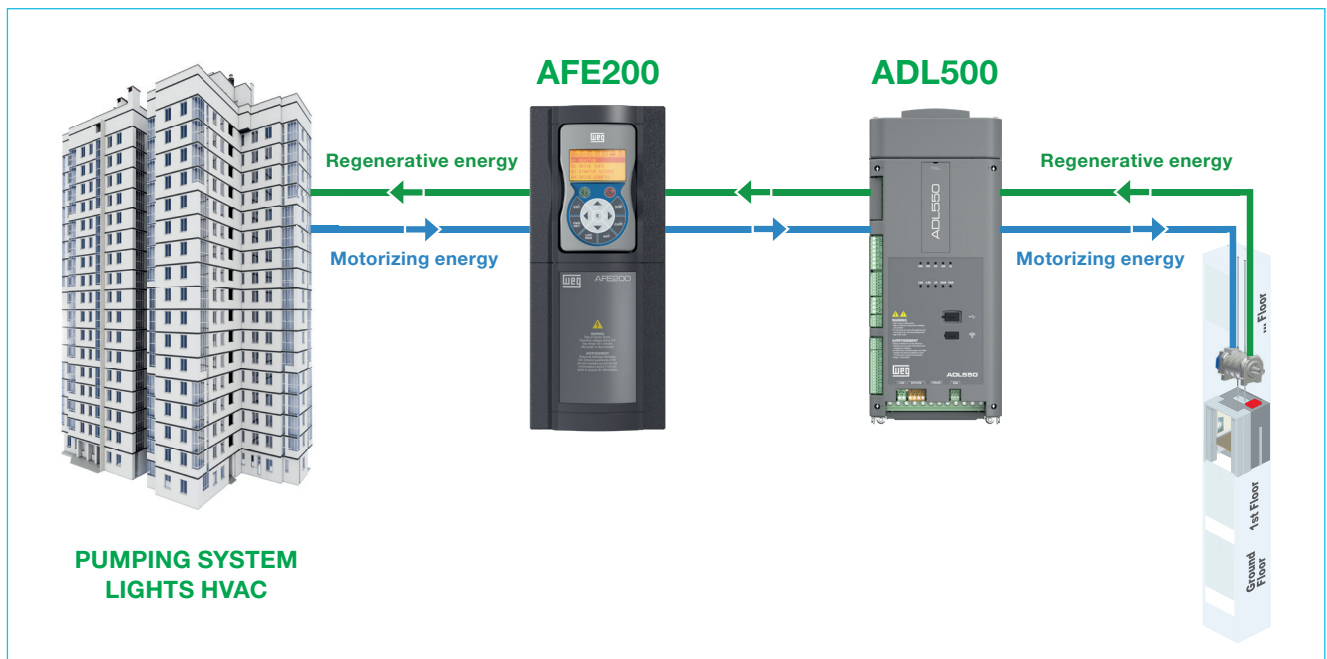
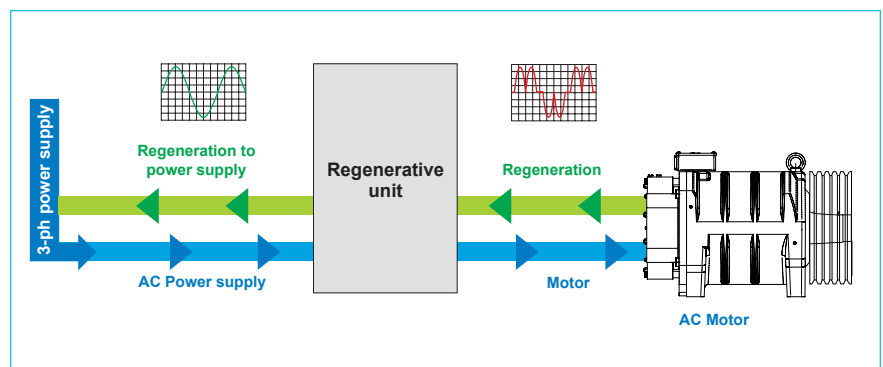

More efficient buildings

In addition to reducing installation space (because braking resistors are no longer needed), this solution reduces the building’s energy consumption, most of which is attributable to air conditioning systems, refrigeration, pump systems, and lifts. Regenerative systems can be used with external Active Front End (AFE) solutions (coupled with the ADL500 series).

WEG reserves the right to make changes and variations to products, data, dimensions at any time without the obligation of prior notice. The data indicated are provided for the sole purpose of describing the product and must not be considered as legally binding characteristics.

Notes

Global presence

is essential, as much
as understanding
your needs.

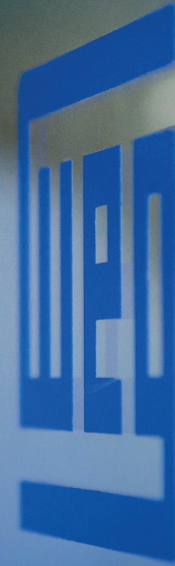

Global Presence

With more than 40,000 employees worldwide, WEG is one of the largest electric motors, electronic equipments and systems manufacturers. We are constantly expanding our portfolio of products and services with expertise and market knowledge. We create integrated and customized solutions ranging from innovative products to complete after-sales service.

WEG's know-how guarantees our **ADL500 - The Ultimate Inverter for Elevator** is the right choice for your application and business, assuring safety, efficiency and reliability.



Availability is to have a global support network



Partnership is to create solutions that suits your needs



Competitive edge is to unite technology and innovation



Know More

High performance and reliable products to improve your production process.



Excellence is to provide a whole solution in industrial automation that improves our customers productivity.

Visit: www.weg.net

 youtube.com/wegvideos

The scope of WEG Group solutions
is not limited to products and solutions
presented in this catalogue.

To see our portfolio, contact us.

**For WEG's worldwide
operations visit our website**



www.weg.net



 +39 02 967601

 info.motion@weg.net

 Gerenzano (VA) Italy

Cod: 50126885 | Rev: 02 | Date (m/y): 10/2024.

The values shown are subject to change without prior notice.
The information contained is reference values.