

Frequency Inverter

Convertidor de Frecuencia

Inversor de Frequência

Frequenzumrichter

Variateur de Vitesse

Frekvensomvandlare

CFW-10

**User's Manual
Manual del Usuario
Manual do Usuário
Bedienungsanleitung
Manuel d'utilisation
Användarinstruktioner**

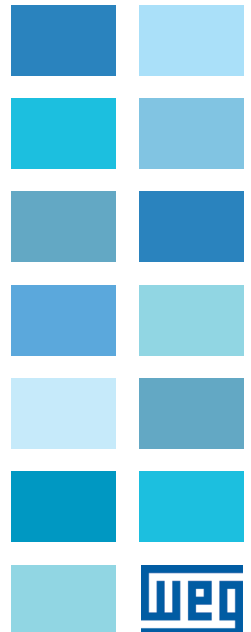

FREQUENCY INVERTER MANUAL

Series: CFW-10

Software: version 2.XX

Language: English

Document: 0899.5202 / 08

05/2012



ATTENTION!

It is very important to check if the inverter software version is the same as indicated above.

Summary of Revisions

The table below describes all revisions made to this manual.

| Revision | Description | Section |
|-----------------|--|----------------|
| 1 | First Edition | - |
| 2 | Addition of the CFW10 MECII and addition of the EMC filter for MECI. General revision. | - |
| 3 | Addition of the CFW10 Size III and Addition of the EMC filter for sizes II and III. | - |
| 4 | CFW 10 Plus and Clean versions inclusion | - |
| 5 | Inclusion of the three-phase and Cold Plate models, and the models with Built-in filter. | - |
| 6 | Revision in the text of parameter P206 – Auto-Reset Time | 6 |

Quick Parameter Reference, Fault and Status Messages

| | | |
|-----|----------------------|----|
| I | Parameters | 08 |
| II | Fault Messages | 11 |
| III | Other Messages | 11 |

CHAPTER 1 *Safety Notices*

| | | |
|-----|------------------------------------|----|
| 1.1 | Safety Notices in the Manual | 12 |
| 1.2 | Safety Notice on The Product | 12 |
| 1.3 | Preliminary Recommendations | 12 |

CHAPTER 2 *General Information*

| | | |
|-----|-----------------------------|----|
| 2.1 | About this Manual | 14 |
| 2.2 | Software Version | 14 |
| 2.3 | About the CFW-10 | 15 |
| 2.4 | CFW-10 Identification | 19 |
| 2.5 | Receiving and Storing | 21 |

CHAPTER 3 *Installation and Connection*

| | | |
|---------|---|----|
| 3.1 | Mechanical Installation | 22 |
| 3.1.1 | Environment | 22 |
| 3.1.2 | Dimensional of CFW-10 | 22 |
| 3.1.3 | Mounting Specification | 25 |
| 3.1.3.1 | Panel Mounting | 26 |
| 3.1.3.2 | Mounting Surface | 26 |
| 3.2 | Electrical Installation | 26 |
| 3.2.1 | Power and Grounding Terminals | 27 |
| 3.2.2 | Location of the Power, Grounding and Control Connections | 28 |
| 3.2.3 | Wiring and Fuses for Power and Grounding | 28 |
| 3.2.4 | Power Connections | 29 |
| 3.2.4.1 | AC Input Connection | 31 |
| 3.2.4.2 | Output Connection | 32 |
| 3.2.4.3 | Grounding Connections | 32 |
| 3.2.5 | Signal and Control Connections | 34 |
| 3.2.6 | Typical Terminal Connections | 36 |
| 3.3 | European EMC Directive - Requirements for Conforming Installations | 38 |
| 3.3.1 | Installation | 39 |

| | |
|---|----|
| 3.3.2 Specification of the Emission and Immunity Levels | 40 |
| 3.3.3 Inverter and Filters | 41 |
| 3.3.4 Characteristics of the EMC Filters | 43 |

CHAPTER 4

Keypad (HMI) Operation

| | |
|---|----|
| 4.1 Keypad (HMI) Description | 47 |
| 4.2 Use of the Keypad (HMI) | 48 |
| 4.2.1 Keypad (HMI) Operation | 48 |
| 4.2.2 Inverter Status - HMI Display | 49 |
| 4.2.3 Read-Only Variables | 50 |
| 4.2.4 Parameter Viewing and Programming | 50 |

CHAPTER 5

Start-up

| | |
|---|----|
| 5.1 Pre-Power Checks | 52 |
| 5.2 Initial Power-up | 52 |
| 5.3 Start-up | 53 |
| 5.3.1 Start-up Operation via Keypad (HMI) | 53 |
| 5.3.2 Start-up Operation via Terminals | 54 |

CHAPTER 6

Detailed Parameter Description

| | |
|--|----|
| 6.1 Symbols | 55 |
| 6.2 Introduction | 55 |
| 6.2.1 V/F (Scalar) Control | 55 |
| 6.2.2 Frequency Reference Sources | 56 |
| 6.2.3 Commands | 59 |
| 6.2.4 Local/Remote Operation Modes | 59 |
| 6.3 Parameter Listing | 60 |
| 6.3.1 Access and Read Only Parameters - P000 to P099 | 61 |
| 6.3.2 Regulation Parameters - P100 to P199 | 62 |
| 6.3.3 Configuration Parameters - P200 to P398 | 71 |
| 6.3.4 Special Functions Parameters - P500 to P599 | 88 |
| 6.3.4.1 Introduction | 88 |
| 6.3.4.2 Description | 88 |
| 6.3.4.3 Start up Guide | 91 |

CHAPTER 7

Diagnostics and Troubleshooting

| | |
|--------------------------------------|-----|
| 7.1 Faults and Possible Causes | 96 |
| 7.2 Troubleshooting | 98 |
| 7.3 Contacting WEG | 99 |
| 7.4 Preventive Maintenance | 99 |
| 7.4.1 Cleaning Instructions | 100 |

CHAPTER 8

Options and Accessories

| | |
|---------------------------------|-----|
| 8.1 RFI Filter | 101 |
| 8.2 Line Reactor | 102 |
| 8.2.1 Application Criteria..... | 102 |
| 8.3 Load Reactor..... | 104 |
| 8.4 Rheostatic Braking | 104 |
| 8.4.1 Sizing | 105 |
| 8.4.2 Installation | 106 |

CHAPTER 9

Technical Specifications

| | |
|--|-----|
| 9.1 Power Data | 108 |
| 9.1.1 Power Supply: 200/240 V - Single-phase | 108 |
| 9.1.2 Power Supply: 200/240 V - Three-phase | 108 |
| 9.1.3 Power Supply: 110-127 V - Single-phase | 109 |
| 9.2 Electronic/General Data | 110 |

CFW-10 - QUICK PARAMETER REFERENCE

QUICK PARAMETER REFERENCE, FAULT AND STATUS MESSAGES

Software: V2.XX

Application:

Model:





Serial Number:

Responsible:

Date: / / .

I. Parameters

| Parameter | Function | Adjustable Range | Factory Setting | Unit | User Setting | Page |
|---|---|---|-----------------|------|--------------|------|
| P000 | Access Parameter | 0 to 4, 6 to 999 = Read 5 = Alteration | 0 | - | | 61 |
| READ ONLY PARAMETERS - P002 to P099 | | | | | | |
| P002 | Frequency Proportional Value (P208 x P005) | 0.0 to 999 | - | - | | 61 |
| P003 | Motor Current (Output) | 0 to $1.5 \times I_{nom}$ | - | A | | 61 |
| P004 | DC Link Voltage | 0 to 524 | - | V | | 61 |
| P005 | Motor Frequency (Output) | 0.0 to 99.9, 100 to 300 | - | Hz | | 61 |
| P007 | Motor Voltage (Output) | 0 to 240 | - | V | | 61 |
| P008 | Heatsink Temperature | 25 to 110 | - | °C | | 61 |
| P014 | Last Fault | 00 to 41 | - | - | | 61 |
| P015 | Second Fault Occurred | 00 to 41 | - | - | | 61 |
| P016 | Third Fault Occurred | 00 to 41 | - | - | | 61 |
| P023 | Software Version | x.yz | - | - | | 61 |
| P040 | PID Process Variable | 0.0 to 999 | - | - | | 62 |
| REGULATION PARAMETERS - P100 to P199 | | | | | | |
| Ramps | | | | | | |
| P100 | Acceleration Time | 0.1 to 999 | 5.0 | s | | 62 |
| P101 | Deceleration Time | 0.1 to 999 | 10.0 | s | | 62 |
| P102 | Acceleration Time Ramp 2 | 0.1 to 999 | 5.0 | s | | 62 |
| P103 | Deceleration Time Ramp 2 | 0.1 to 999 | 10.0 | s | | 62 |
| P104 | S Ramp | 0 = Inactive 1 = 50 2 = 100 | 0 | % | | 62 |
| Frequency Reference | | | | | | |
| P120 | Digital Reference Backup | 0 = Inactive 1 = Active 2 = Backup by P121 3 = Active after Ramp | 1 | - | | 63 |
| P121 | Keypad Frequency Reference | P133 to P134 | 3.0 | Hz | | 64 |
| P122 | JOG Speed Reference | P133 to P134 | 5.0 | Hz | | 64 |
| P124 | Multispeed Reference 1 | P133 to P134 | 3.0 | Hz | | 64 |
| P125 | Multispeed Reference 2 | P133 to P134 | 10.0 | Hz | | 64 |
| P126 | Multispeed Reference 3 | P133 to P134 | 20.0 | Hz | | 64 |
| P127 | Multispeed Reference 4 | P133 to P134 | 30.0 | Hz | | 64 |
| P128 | Multispeed Reference 5 | P133 to P134 | 40.0 | Hz | | 65 |
| P129 | Multispeed Reference 6 | P133 to P134 | 50.0 | Hz | | 65 |
| P130 | Multispeed Reference 7 | P133 to P134 | 60.0 | Hz | | 65 |
| P131 | Multispeed Reference 8 | P133 to P134 | 66.0 | Hz | | 65 |
| Frequency Limits | | | | | | |
| P133 | Minimum Frequency (F_{min}) | 0.00 to P134 | 3.0 | Hz | | 66 |
| P134 | Maximum Frequency (F_{max}) | P133 to 300 | 66.0 | Hz | | 66 |

| Parameter | Function | Adjustable Range | Factory Setting | Unit | User Setting | Page |
|--|---|--|---|------|--------------|------|
| V/F Control | | | | | | |
| P136 | Manual Torque Boost (I x R Compensation) | 0.0 to 100 | 20.0 ⁽³⁾ | % | | 66 |
| P137 | Automatic Torque Boost (Automatic I x R Compensation) | 0.0 to 100 | 0.0 | % | | 67 |
| P138 | Slip Compensation | 0.0 to 10.0 | 0.0 | % | | 68 |
| P142 ^{(1) (2)} | Maximum Output Voltage | 0.0 to 100 | 100 | % | | 69 |
| P145 ^{(1) (2)} | Field Weakening Frequency (F _{nom}) | P133 to P134 | 60.0 | Hz | | 69 |
| DC Link Voltage Regulation | | | | | | |
| P151 | Actuation Level of the Voltage Regulation at the DC Link (Intermediary Circuit) | Model 100: 360 to 460 Model 200: 325 to 410 | 430 380 | V | | 69 |
| Overload Current | | | | | | |
| P156 ⁽²⁾ | Motor Overload Current | 0.3 x I _{nom} to 1.3 x I _{nom} | 1.2 x P295 | A | | 70 |
| Current Limitation | | | | | | |
| P169 ⁽²⁾ | Maximum Output Current | 0.2 x I _{nom} to 2.0 x I _{nom} | 1.5 x P295 | A | | 71 |
| CONFIGURATION PARAMETERS - P200 to P398 | | | | | | |
| Generic Parameters | | | | | | |
| P202 ⁽¹⁾ | Control Mode | 0 = Linear V/F Control 1 = Quadratic V/F Control | 0 | - | | 71 |
| P203 | Special Functions Selection | 0 = None 1 = PID Regulator | 0 | - | | 73 |
| P204 ⁽¹⁾ | Load Parameters with Factory Setting | 0 to 4 = Not used 5 = Load Factory Default 6 to 999 = Not used | 0 | - | | 73 |
| P206 | Auto-Reset Time | 0 to 255 | 0 | s | | 73 |
| P208 | Reference Scale Factor | 0.0 to 100 | 1.0 | - | | 73 |
| P219 ⁽¹⁾ | Starting Point of the Switching Frequency Reduction | 0.0 to 15.0 | 15.0 | Hz | | 73 |
| Local/Remote Definition | | | | | | |
| P221 ⁽¹⁾ | Speed Reference Selection – Local Mode | 0 = HMI Keys  /  1 = AI1 2 = EP 3 = HMI Potentiometer 4 to 5 = Reserved 6 = Multispeed 7 = Frequency Input | 0 = For Inverters Standard and Clean Versions 3 = For Inverters Plus Version | - | | 74 |
| P222 ⁽¹⁾ | Speed Reference Selection - Remote Mode | 0 = HMI Keys  /  1 = AI1 2 = EP 3 = HMI Potentiometer 4 to 5 = Reserved 6 = Multispeed 7 = Frequency Input | 1 | - | | 74 |
| P229 ⁽¹⁾ | Command Selection - Local Mode | 0 = HMI Keypad 1 = Terminals | 0 | - | | 74 |
| P230 ⁽¹⁾ | Command Selection - Remote Mode | 0 = HMI Keypad 1 = Terminals | 1 | - | | 74 |

CFW-10 - QUICK PARAMETER REFERENCE

| Parameter | Function | Adjustable Range | Factory Setting | Unit | User Setting | Page |
|-------------------------|---|--|-----------------|------|--------------|------|
| P231 ⁽¹⁾ | Forward/Reverse Selection | 0 = Forward 1 = Reverse 2 = Commands | 2 | - | | 75 |
| Analog Inputs(s) | | | | | | |
| P234 | Analog Input AI1 Gain | 0.0 to 999 | 100 | % | | 75 |
| P235 ⁽¹⁾ | Analog Input AI1 Signal | 0 = (0 to 10) V/ (0 to 20) mA 1 = (4 to 20) mA | 0 | - | | 78 |
| P236 | Analog Input AI1 Offset | -120 to +120 | 0 | % | | 78 |
| P238 | Input Gain(HMI Potentiometer) | 0.0 to 999 | 100 | % | | 78 |
| P240 | Input Offset(HMI Potentiometer) | -120 to +120 | 0 | % | | 78 |
| P248 | Analog Input (AI1) Filter Time Constant | 0 to 200 | 200 | ms | | 78 |
| Digital Inputs | | | | | | |
| P263 ⁽¹⁾ | Digital Input DI1 Function | 0 = No Function 1 = No Function or General Enable | 1 | - | | 78 |
| P264 ⁽¹⁾ | Digital Input DI2 Function | 2 = General Enable | 5 | - | | 78 |
| P265 ⁽¹⁾ | Digital Input DI3 Function | 3 = JOG 4 = Start/Stop | 6 | - | | 78 |
| P266 ⁽¹⁾ | Digital Input DI4 Function | 5 = Forward/Reverse 6 = Local/Remote 7 = Multispeed 8 = Multispeed using Ramp2 9 = Forward 10 = Reverse 11 = Forward with Ramp 2 12 = Reverse with Ramp 2 13 = On 14 = Off 15 = Activates ramp 2 16 = Accelerates EP 17 = Decelerates EP 18 = Accelerates EP with Ramp2 19 = Decelerates EP with Ramp2 20 = Without External Fault 21 = Error Reset 22 = Start/Accelerate EP 23 = Decelerate EP/Stop 24 = Stop 25 = Security Switch 26 = Frequency Input 27 = Manual/Automatic (PID) | 4 | - | | 79 |
| P271 | Frequency Input Gain | 0.0 to 999 | 200 | % | | 84 |
| Digital Outputs | | | | | | |
| P277 ⁽¹⁾ | Relay Output RL1 Function | 0 = Fs > Fx 1 = Fe > Fx 2 = Fs = Fe 3 = Is > Ix 4 and 6 = Not Used 5 = Run 7 = Not Fault | 7 | - | | 84 |

| Parameter | Function | Adjustable Range | Factory Setting | Unit | User Setting | Page |
|--|--|--|---------------------|------|--------------|------|
| Fx and Ix | | | | | | |
| P288 | Fx Frequency | 0.0 to P134 | 3.0 | Hz | | 85 |
| P290 | Ix Current | 0.0 to 1.5 x I _{nom} | P295 | A | | 85 |
| Inverter Data | | | | | | |
| P295 | Rated Inverter Current (I _{nom}) | 1.6 2.6 4.0 7.3 10.0 15.2 | Read only Parameter | A | | 85 |
| P297⁽¹⁾ | Switching Frequency | 2.5 to 15.0 | 5.0 ⁽⁴⁾ | kHz | | 86 |
| DC Braking | | | | | | |
| P300 | DC Braking Time | 0.0 to 15.0 | 0.0 | s | | 86 |
| P301 | DC Braking Start Frequency | 0.0 to 15.0 | 1.0 | Hz | | 86 |
| P302 | Braking Torque | 0.0 to 100 | 50.0 | % | | 86 |
| SPECIAL FUNCTION - P500 to P599 | | | | | | |
| PID Regulator | | | | | | |
| P520 | PID Proportional Gain | 0.0 to 999 | 100 | % | | 94 |
| P521 | PID Integral Gain | 0.0 to 999 | 100 | % | | 94 |
| P522 | PID Differential Gain | 0.0 to 999 | 0 | % | | 94 |
| P525 | PID Regulator Set point via keypad | 0.0 to 100 | 0 | % | | 94 |
| P526 | Process Variable Filter | 0.0 to 10.0 | 0.1 | s | | 94 |
| P527 | PID Regulator Action Type | 0 = Direct 1 = Reverse | 0 | - | | 94 |
| P528 | Proc. Var. Scale Factor | 0 to 999 | 100 | - | | 95 |
| P536 | Automatic Setting of P525 | 0 = Active 1 = Inactive | 0 | - | | 95 |

(1) This parameter can be changed only with the inverter disabled (stopped motor).

(2) This Parameter cannot be changed when the routine "load factory default" is executed (P204 = 5).

(3) 6 % for the 15.2 A model.

(4) 2.5 kHz for the 15.2 A model.

II. Fault Messages

| Display | Description | Page |
|------------|---|------|
| E00 | Output Overcurrent/Short-Circuit | 96 |
| E01 | DC Link Overvoltage | 96 |
| E02 | DC Link Undervoltage | 96 |
| E04 | Inverter Overtemperature | 97 |
| E05 | Output Overload (I _x t function) | 97 |
| E06 | External Fault | 97 |
| E08 | CPU Error (watchdog) | 97 |
| E09 | Program Memory Error (checksum) | 97 |
| E24 | Programming Error | 97 |
| E31 | Keypad (HMI) Communication Fault | 97 |
| E41 | Self-Diagnosis Error | 97 |

III. Other Messages

| Display | Description |
|------------|---|
| rdy | Inverter is ready to be enabled |
| Sub | Power supply voltage is too low for the inverter operation (undervoltage) |
| dcb | Inverter in DC braking mode |
| EPP | Inverter is loading factory setting |

SAFETY NOTICES

This manual contains necessary information for the correct use of the CFW-10 Variable Frequency Drive.

This manual has been written for qualified personnel with suitable training and technical qualification to operate this type of equipment.

1.1 SAFETY NOTICES IN THE MANUAL

The following Safety Notices will be used in this manual:



DANGER!

If the recommended Safety Notices are not strictly observed, it can lead to serious or fatal injuries of personnel and/or material damage.



ATTENTION!

Failure to observe the recommended Safety Procedures can lead to material damage.



NOTE!

The content of this manual supplies important information for the correct understanding of operation and proper performance of the equipment.

1.2 SAFETY NOTICE ON THE PRODUCT

The following symbols may be attached to the product, serving as Safety Notice:



High Voltages



Components sensitive to electrostatic discharge. Do not touch them without proper grounding procedures.



Mandatory connection to ground protection (PE)



Shield connection to ground

1.3 PRELIMINARY RECOMMENDATIONS



DANGER!

Only qualified personnel should plan or implement the installation, start-up, operation and maintenance of this equipment. Personnel must review entire Manual before attempting to install, operate or troubleshoot the CFW-10.

These personnel must follow all safety instructions included in this Manual and/or defined by local regulations.

Failure to comply with these instructions may result in personnel injury and/or equipment damage.



NOTE!

In this manual, qualified personnel are defined as people that are trained to:

1. Install, ground, power up and operate the CFW-10 according to this manual and the local required safety procedures;
2. Use of safety equipment according to the local regulations;
3. Administer First Aid.



DANGER!

The inverter control circuit (CCP10, DSP) and the HMI-CFW-10 are not grounded. They are high voltage circuits.



DANGER!

Always disconnect the supply voltage before touching any electrical component inside the inverter.

Many components are charged with high voltages, even after the incoming AC power supply has been disconnected or switched OFF. Wait at least 10 minutes for the total discharge of the power capacitors.



Always connect the frame of the equipment to the ground (PE) at the suitable connection point.

CFW-10 drive must be grounded appropriately for safety purposes (PE).



ATTENTION!

All electronic boards have components that are sensitive to electrostatic discharges. Never touch any of the electrical components or connectors without following proper grounding procedures. If necessary to do so, touch the properly grounded metallic frame or use a suitable ground strap.

**Do not apply High Voltage (High Pot) Test on the inverter!
If this test is necessary, contact the Manufacturer.**



NOTE!

Inverters can interfere with other electronic equipment. In order to reduce this interference, adopt the measures recommended in Section 3 "Installation".



NOTE!

Read this entire manual carefully and completely before installing or operating the CFW-10.

GENERAL INFORMATION

This chapter defines the contents and purposes of this manual and describes the main characteristics of the CFW-10 frequency inverter. Identification, receiving inspections and storage requirements are also provided.

2.1 ABOUT THIS MANUAL

This Manual is divided into 9 Chapter, providing information to the user on receiving, installation, start-up and operation:

- Chapter 1 - Safety Notices.
- Chapter 2 - General Informations and Receiving the CFW-10.
- Chapter 3 - CFW-10 and RFI Filters - Mechanical and Electrical Installation (power and control circuitry).
- Chapter 4 - Using the Keypad (Human Machine Interface - HMI).
- Chapter 5 - Start-up - Steps to follow.
- Chapter 6 - Setup and Read-only Parameters-Detailed description.
- Chapter 7 - Solving problems, cleaning instructions and preventive maintenance.
- Chapter 8 - CFW-10 Optional Devices - Description, technical characteristics and installation.
- Chapter 9 - CFW-10 ratings - Tables and technical information.

This Manual provides information for the correct use of the CFW-10. The CFW-10 is very flexible and allows the operation in many different modes as described in this manual.

As the CFW-10 can be applied in several ways, it is impossible to describe here all of the application possibilities. WEG does not accept any responsibility when the CFW-10 is not used according to this Manual.

No part of this Manual may be reproduced in any form, without the written permission of WEG.

2.2 SOFTWARE VERSION

It is important to note the Software Version installed in the CFW-10, since it defines the functions and the programming parameters of the inverter.

This manual refers to the software version indicated on the inside cover. For example, the Version 1.0X applies to versions 1.00 to 1.09, where "X" is a variable that will change due to minor software revisions.

The Software Version can be read in the Parameter P023.

2.3 ABOUT THE CFW-10

The CFW-10 frequency inverter is fitted with the V/F (scalar) control method.

The V/F (scalar) mode is recommended for more simple applications such as pump and fan drives. In these cases one can reduce the motor and inverter losses by using the "Quadratic V/F" option, that results in energy saving.

The V/F mode is also used when more than one motor should be driven simultaneously by one inverter (multimotor application).

Chapter 9 shows the different power lines and additional technical information

The block diagram below gives a general overview of the CFW-10.

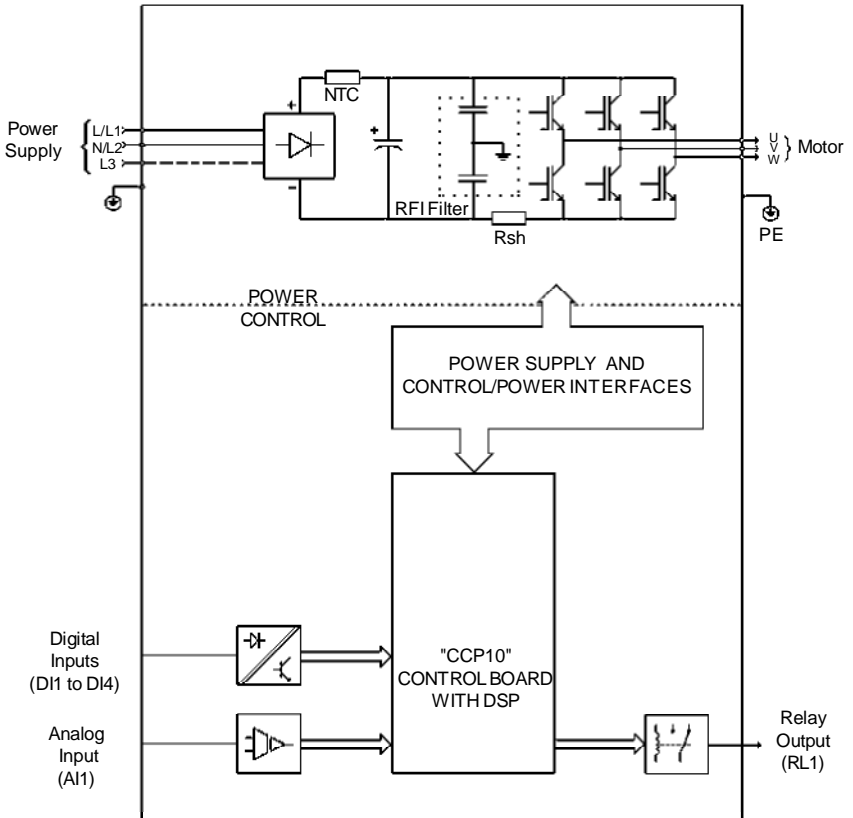

Figure 2.1 - CFW-10 Block Diagram for models 1.6 A, 2.6 A and 4.0 A /200-240 V (single-phase) and 1.6 A, 2.6 A, 4.0 A and 7.3 A/200-240 V (three-phase)

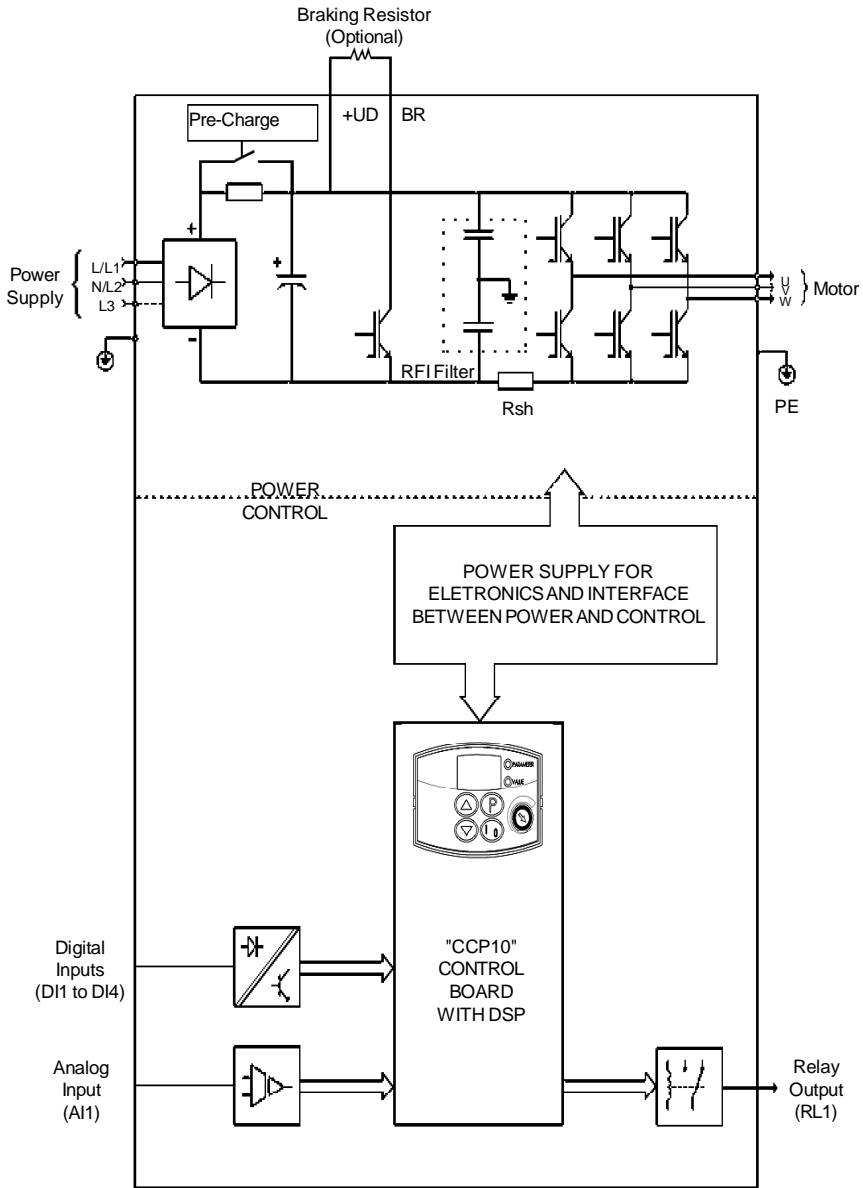

Figure 2.2 - CFW-10 Block Diagram for model 7.3 A and 10.0 A/200-240 V (single-phase) and 10.0 A and 15.2 A/200-240 V (three-phase)

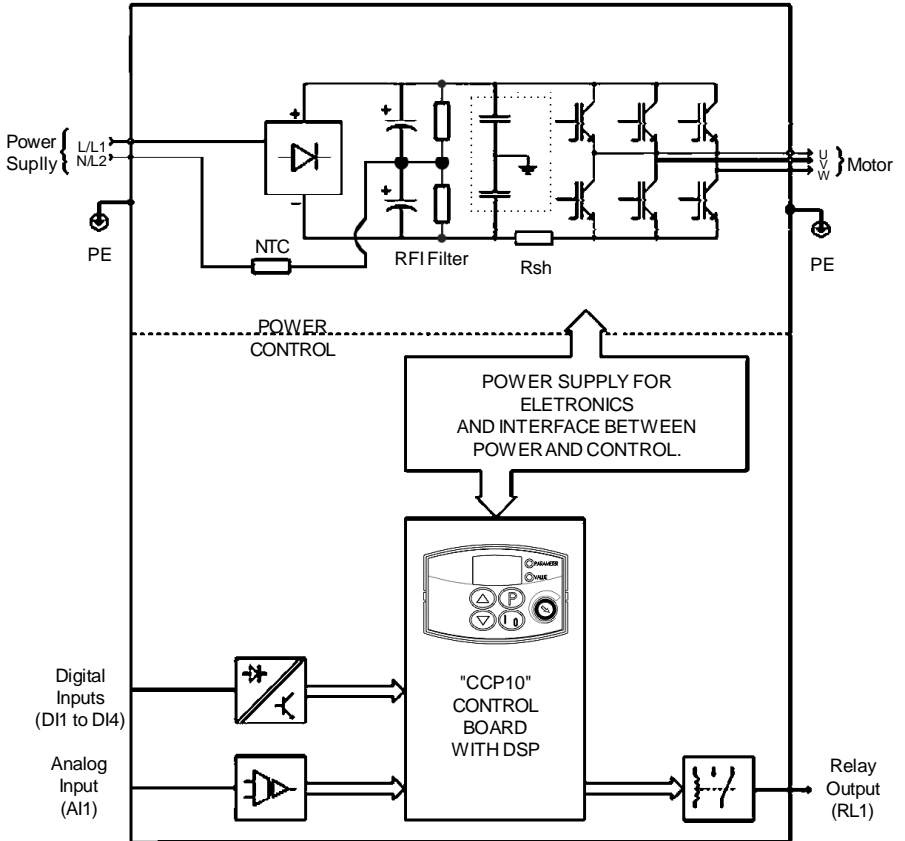

Figure 2.3 - CFW-10 Block Diagram for model 1.6 A and 2.6 A/110-127 V

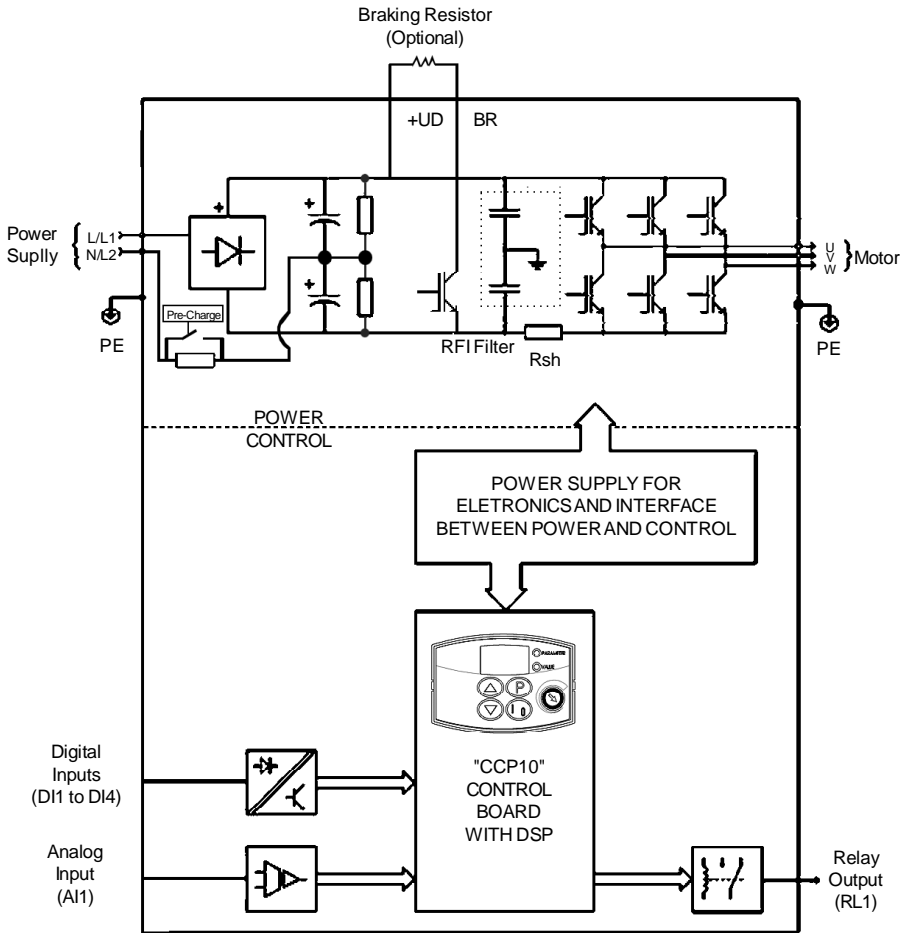
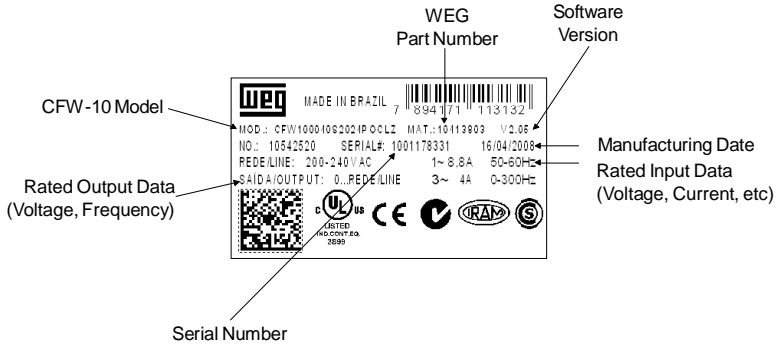

Figure 2.4 - CFW-10 Block Diagram for model 4.0 A/110-127 V

2.4 CFW-10 IDENTIFICATION



Lateral Nameplate CFW-10

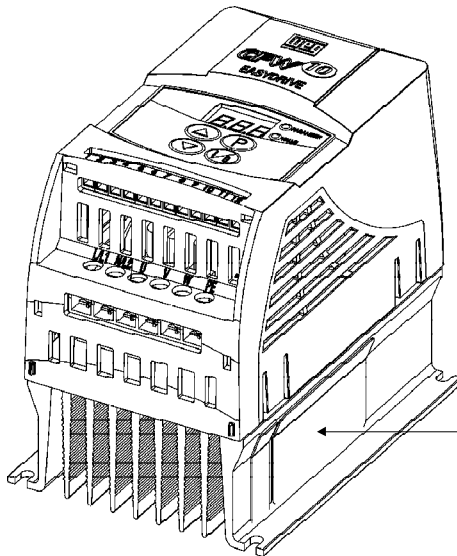

Figure 2.5 - Description and Location of the Nameplate

HOW TO SPECIFY THE CFW-10 MODEL

| CFW-10 | 0040 | S | 2024 | P | O | Control Board: | Built-in EMC filter: | Special Hardware | Special Software | Z |
|----------------------------------|--|---|---|--|--|---|--|--|------------------|----------|
| WEG Series 10 Frequency Inverter | Rated Output Current for 220 to 240 V: 0016 = 1.6 A 0026 = 2.6 A 0040 = 4.0 A 0073 = 7.3 A 0100 = 10.0 A 0152 = 15.2 A 110 to 127 V: 0016 = 1.6 A 0026 = 2.6 A 0040 = 4.0 A | Number of phases of the power supply S = single-phase T = three-phase | Power supply: 2024 = 200 to 240 V 1112 = 110 to 127 V | Manual Language: P = Portuguese E = English S = Spanish G = German | Options: S = standard O = with options | Blank = standard control CL = Clean PL = Plus | Blank = standard FA = with EMC (class A) filter | Blank = standard CP = Cold Plate heatsink version | Blank = standard | End Code |



NOTE!

- ☑ The Option field (S or O) defines if the CFW-10 is a standard version or if it will be equipped with any optional devices. If the standard version is required, the specification code ends here.
- The model number has always the letter Z at the end. For example:
CFW100040S2024ESZ = standard 4.0 A CFW-10 inverter, single-phase at 200 V to 240 V input with manual in English.
- ☑ If the CFW-10 is equipped with any optional devices, you must fill out all fields in the correct sequence up to the last optional device, the model number is completed with the letter Z.

2.5 RECEIVING
AND STORING

The CFW-10 is supplied in cardboard boxes.

There is a nameplate on the outside of the packing box that is identical to that one on the CFW-10.

Check if the:

- CFW-10 nameplate data matches with your purchase order.
- The equipment has not been damaged during transport.

If any problem is detected, contact the carrier immediately.

If the CFW-10 is not installed immediately, store it in a clean and dry room (storage temperatures between -25 °C and 60 °C). Cover it to protect it against dust, dirt or other contamination.



ATTENTION!

When stored for a long time, it is recommended to power up and keep the drive running for 1 hour every year. Make sure to use a single-phase power supply (50 or 60 Hz) that matches the drive rating without connecting the motor to its output. After powering up the drive, keep it off for 24 hours before using it again.

INSTALLATION AND CONNECTION

This chapter describes the procedures for the electrical and mechanical installation of the CFW-10.

These guidelines and suggestions must be followed for proper operation of the CFW-10.

3.1 MECHANICAL INSTALLATION

3.1.1 Environment

The location of the inverter installation is an important factor to assure good performance and high product reliability. For proper installation, we make the following recommendations:

- ☑ Avoid direct exposure to sunlight, rain, high moisture and sea air.
- ☑ Avoid exposure to gases or explosive or corrosive liquids;
- ☑ Avoid exposure to excessive vibration, dust, oil or any conductive particles or materials.

Environmental Conditions:

- ☑ Temperature : 0 °C to 50 °C (32 °F to 122 °F) - nominal conditions, except for the 15.2 A model with Built-in filter (0 to 40 °C).
- ☑ Relative Air Humidity: 5 % to 90 % - non-condensing.
- ☑ Maximum Altitude: 1000 m (3.300 ft) - nominal conditions.
From 1000 m to 4000 m (3.300 ft to 13.200 ft): with 1 % current derating for each 100 m (330 ft) above 1000 m (3.300 ft).
- ☑ Pollution Degree: 2 (according to EN50178 and UL508C).

3.1.2 Dimensional of CFW-10

External dimensions and mounting holes for the CFW-10 shall be according to figure 3.1 and table 3.1.

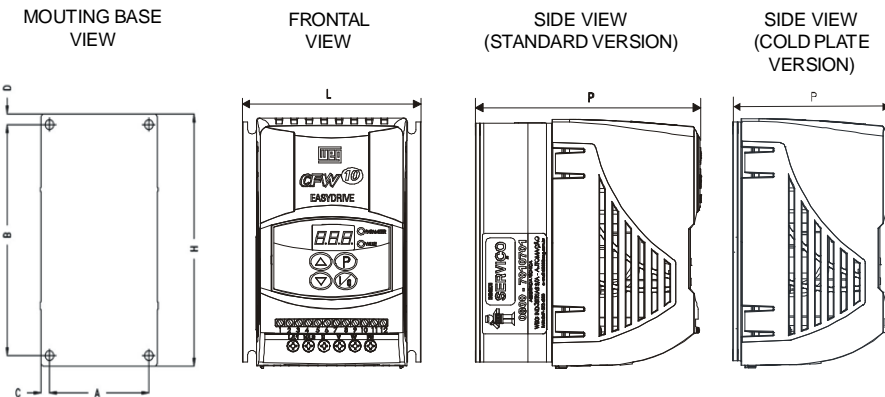

Figure 3.1 - Dimensional of CFW-10 - Sizes 1, 2 and 3

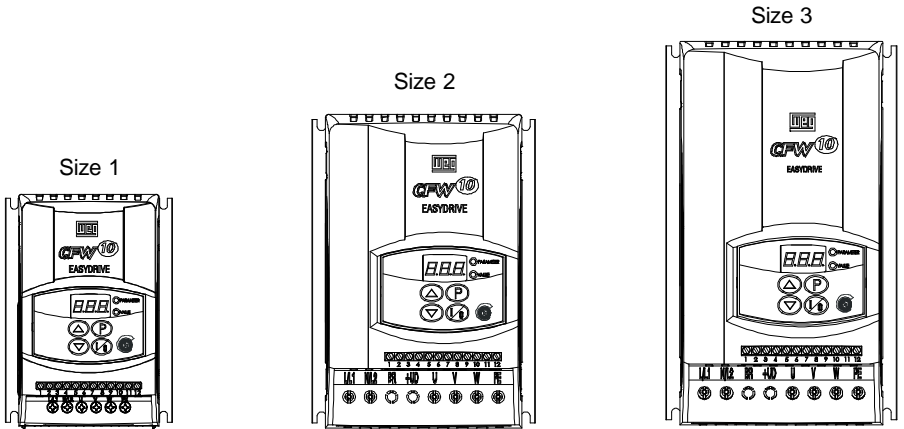

Figure 3.1 - Dimensional of CFW-10 - Sizes 1, 2 and 3

| Model | Dimensions | | | Fixing Base | | | | Mounting Screw | Weight [kg] (lb) | Degree of Protection |
|--------------------|-------------------|--------------------|-------------------|-------------|-------------|-------------|-------------|----------------|------------------|----------------------|
| | Width L [mm] (in) | Height H [mm] (in) | Depth P [mm] (in) | A [mm] (in) | B [mm] (in) | C [mm] (in) | D [mm] (in) | | | |
| SINGLE-PHASE | | | | | | | | | | |
| 1.6 A / 200-240 V | 95 (3.74) | 132 (5.20) | 121 (4.76) | 85 (3.35) | 120 (4.72) | 5 (0.2) | 6 (0.24) | M4 | 0.9 (1.98) | IP20 |
| 2.6 A / 200-240 V | 95 (3.74) | 132 (5.20) | 121 (4.76) | 85 (3.35) | 120 (4.72) | 5 (0.2) | 6 (0.24) | M4 | 0.9 (1.98) | IP20 |
| 4.0 A / 200-240 V | 95 (3.74) | 132 (5.20) | 121 (4.76) | 85 (3.35) | 120 (4.72) | 5 (0.2) | 6 (0.24) | M4 | 0.9 (1.98) | IP20 |
| 7.3 A / 200-240 V | 115 (4.53) | 161 (6.34) | 122 (4.8) | 105 (4.13) | 149 (5.83) | 5 (0.2) | 6 (0.24) | M4 | 1.5 (3.31) | IP20 |
| 10.0 A / 200-240 V | 115 (4.53) | 191 (7.46) | 122 (4.8) | 105 (4.13) | 179 (7.05) | 5 (0.2) | 6 (0.24) | M4 | 1.8 (3.96) | IP20 |
| 1.6 A / 110-127 V | 95 (3.74) | 132 (5.20) | 121 (4.76) | 85 (3.35) | 120 (4.72) | 5 (0.2) | 6 (0.24) | M4 | 0.9 (1.98) | IP20 |
| 2.6 A / 110-127 V | 95 (3.74) | 132 (5.20) | 121 (4.76) | 85 (3.35) | 120 (4.72) | 5 (0.2) | 6 (0.24) | M4 | 0.9 (1.98) | IP20 |
| 4.0 A / 110-127 V | 115 (4.53) | 161 (6.34) | 122 (4.8) | 105 (4.13) | 149 (5.83) | 5 (0.2) | 6 (0.24) | M4 | 1.5 (3.31) | IP20 |
| THREE-PHASE | | | | | | | | | | |
| 1.6 A / 200-240 V | 95 (3.74) | 132 (5.20) | 121 (4.76) | 85 (3.35) | 120 (4.72) | 5 (0.2) | 6 (0.24) | M4 | 0.9 (1.98) | IP20 |
| 2.6 A / 200-240 V | 95 (3.74) | 132 (5.20) | 121 (4.76) | 85 (3.35) | 120 (4.72) | 5 (0.2) | 6 (0.24) | M4 | 0.9 (1.98) | IP20 |
| 4.0 A / 200-240 V | 95 (3.74) | 132 (5.20) | 121 (4.76) | 85 (3.35) | 120 (4.72) | 5 (0.2) | 6 (0.24) | M4 | 0.9 (1.98) | IP20 |
| 7.3 A / 200-240 V | 95 (3.74) | 132 (5.20) | 121 (4.76) | 85 (3.35) | 120 (4.72) | 5 (0.2) | 6 (0.24) | M4 | 0.9 (1.98) | IP20 |
| 10.0 A / 200-240 V | 115 (4.53) | 161 (6.34) | 122 (4.8) | 105 (4.13) | 149 (5.83) | 5 (0.2) | 6 (0.24) | M4 | 1.5 (3.31) | IP20 |
| 15.2 A / 200-240 V | 115 (4.53) | 191 (7.46) | 122 (4.8) | 105 (4.13) | 179 (7.05) | 5 (0.2) | 6 (0.24) | M4 | 1.8 (3.96) | IP20 |

Table 3.1 a) Installation data (dimensions in mm (in)) – Refer to Section 9.1

CHAPTER 3 - INSTALLATION AND CONNECTION

| Model | Dimensions | | | Fixing Base | | | | Mounting Screw | Weight [kg] (lb) | Degree of Protection |
|---------------------|-------------------|--------------------|-------------------|-------------|-------------|-------------|-------------|----------------|------------------|----------------------|
| | Width L [mm] (in) | Height H [mm] (in) | Depth P [mm] (in) | A [mm] (in) | B [mm] (in) | C [mm] (in) | D [mm] (in) | | | |
| SINGLE-PHASE | | | | | | | | | | |
| 1.6 A / 200-240 V | 100 (3.94) | 132 (5.20) | 82 (3.23) | 90 (3.54) | 120 (4.72) | 5 (0.2) | 6 (0.24) | M4 | 0.7 (1.54) | IP20 |
| 2.6 A / 200-240 V | 100 (3.94) | 132 (5.20) | 82 (3.23) | 90 (3.54) | 120 (4.72) | 5 (0.2) | 6 (0.24) | M4 | 0.7 (1.54) | IP20 |
| 4.0 A / 200-240 V | 100 (3.94) | 132 (5.20) | 82 (3.23) | 90 (3.54) | 120 (4.72) | 5 (0.2) | 6 (0.24) | M4 | 0.7 (1.54) | IP20 |
| 7.3 A / 200-240 V | 120 (4.72) | 161 (6.34) | 82 (3.23) | 110 (4.33) | 149 (5.83) | 5 (0.2) | 6 (0.24) | M4 | 1.0 (2.20) | IP20 |
| 10.0 A / 200-240 V | 120 (4.72) | 191 (7.46) | 82 (3.23) | 110 (4.33) | 179 (7.05) | 5 (0.2) | 6 (0.24) | M4 | 1.2 (2.65) | IP20 |
| 1.6 A / 110-127 V | 100 (3.94) | 132 (5.20) | 82 (3.23) | 90 (3.54) | 120 (4.72) | 5 (0.2) | 6 (0.24) | M4 | 0.7 (1.54) | IP20 |
| 2.6 A / 110-127 V | 100 (3.94) | 132 (5.20) | 82 (3.23) | 90 (3.54) | 120 (4.72) | 5 (0.2) | 6 (0.24) | M4 | 0.7 (1.54) | IP20 |
| 4.0 A / 110-127 V | 120 (4.72) | 161 (6.34) | 82 (3.23) | 110 (4.33) | 149 (5.83) | 5 (0.2) | 6 (0.24) | M4 | 1.0 (2.20) | IP20 |
| THREE-PHASE | | | | | | | | | | |
| 1.6 A / 200-240 V | 100 (3.94) | 132 (5.20) | 82 (3.23) | 90 (3.54) | 120 (4.72) | 5 (0.2) | 6 (0.24) | M4 | 0.7 (1.54) | IP20 |
| 2.6 A / 200-240 V | 100 (3.94) | 132 (5.20) | 82 (3.23) | 90 (3.54) | 120 (4.72) | 5 (0.2) | 6 (0.24) | M4 | 0.7 (1.54) | IP20 |
| 4.0 A / 200-240 V | 100 (3.94) | 132 (5.20) | 82 (3.23) | 90 (3.54) | 120 (4.72) | 5 (0.2) | 6 (0.24) | M4 | 0.7 (1.54) | IP20 |
| 7.3 A / 200-240 V | 100 (3.94) | 132 (5.20) | 82 (3.23) | 90 (3.54) | 120 (4.72) | 5 (0.2) | 6 (0.24) | M4 | 0.7 (1.54) | IP20 |
| 10.0 A / 200-240 V | 120 (4.72) | 161 (6.34) | 82 (3.23) | 110 (4.33) | 149 (5.83) | 5 (0.2) | 6 (0.24) | M4 | 1.0 (2.20) | IP20 |
| 15.2 A / 200-240 V | 120 (4.72) | 191 (7.46) | 82 (3.23) | 110 (4.33) | 179 (7.05) | 5 (0.2) | 6 (0.24) | M4 | 1.2 (2.65) | IP20 |

Table 3.1 b) Cold Plate Version, installation data (dimensions in mm (in)) – Refer to Section 9.1

The Cold Plate version was designed in order to allow mounting the “CP” CFW-10 frequency inverter in any heat dissipation surface, since following recommendations are fulfilled.

INSTALLATING THE FREQUENCY INVERTER ON THE HEAT DISSIPATION SURFACE - STEPS

1. Mark out the positions of the mounting holes on the backing plate where the frequency inverter will be located (see in figure 3.1 drawing and hole size).
2. The surface that is in contact with frequency inverter dissipation surface must be free of dirt and burr. Standard requirements are: the backing plate flatness (considering an area of 100 mm² (0.15 in²)) shall be less than 50 μm and the roughness less than 10 μm.

3. Use (M4) mounting screws in order to fasten the frequency inverter to the base plate.
4. After drilling the holes, clean the contact surface of the backing plate and coat it with a thin thermal paste layer, or with a heat conducting foil or similar product (approx. 100 µm).
5. Continue the mechanical installation as indicated in Chapter 3.1.
6. Electrical installation shall be performed as indicated in the Chapter 3.2.



ATTENTION!

After operation, check P008. This parameter must not exceed 90 °C.

3.1.3 Mounting Specification

Figure 3.2 and table 3.2 show free space requirements to be left around the drive.

Install the drive on a vertical position, following the recommendations listed below:

- 1) Install the drive on a flat surface.
- 2) Do not install heat sensitive components immediately above the drive.



ATTENTION!

When there are other devices installed at the top and at the bottom of the drive, respect the minimum recommended distance (A + B) and deflect the hot air coming from the device below.



ATTENTION!

Provide independent conduits for signal, control and power conductors. (Refer to Electrical Installation). Separate the motor cables from the other cables.

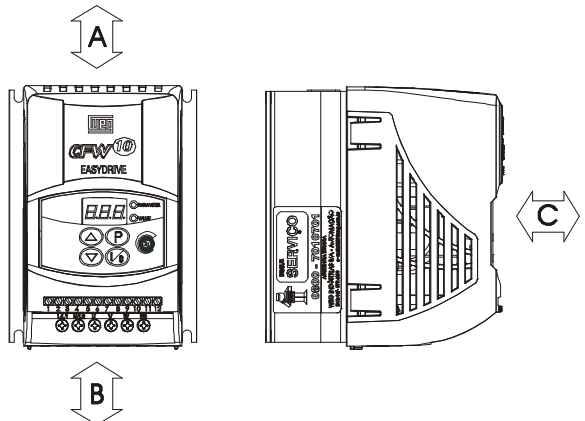

Figure 3.2 - Free-space for Cooling

| CFW-10 Model | A | | B | | C | |
|--------------------|-------|---------|-------|------|-------|------|
| 1.6 A / 200-240 V | 30 mm | 1.18 in | 50 mm | 2 in | 50 mm | 2 in |
| 2.6 A / 200-240 V | | | | | | |
| 4.0 A / 200-240 V | | | | | | |
| 7.3 A / 200-240 V | | | | | | |
| 10.0 A / 200-240 V | | | | | | |
| 15.2 A / 200-240 V | | | | | | |
| 1.6 A / 110-127 V | | | | | | |
| 2.6 A / 110-127 V | | | | | | |
| 4.0 A / 110-127 V | | | | | | |

Table 3.2 - Free space requirements

3.1.3.1 Panel Mounting

When drives are installed inside panels or inside closed metallic boxes, proper cooling is required to ensure that the temperature around the drive will not exceed the maximum allowable temperature. Refer to Section 9.1 for Power Dissipation data.

3.1.3.2 Mounting Surface

Figure 3.3 shows the installation procedure of the CFW-10 on a mounting surface.

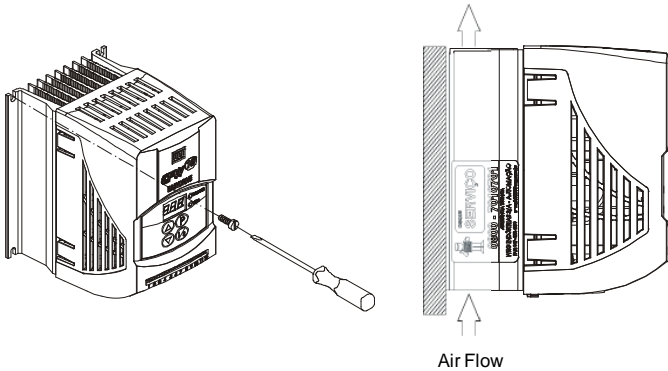

Figure 3.3 - Mounting Procedures for the CFW-10

3.2 ELECTRICAL INSTALLATION



DANGER!

The information below will be a guide to achieve a proper installation. Follow also all applicable local standards for electrical installations.



DANGER!

Be sure the AC input power has been disconnected before making any terminal connection.



DANGER!

The CFW-10 shall not be used as an emergency stop device. Use additional devices proper for this purpose.

3.2.1 Power and Grounding Terminals

Description of the Power Terminals:

- ☑ L/L1, N/L2, L3: AC power supply.
- ☑ U, V and W: Motor connection.
- ☑ PE: Grounding connection.
- ☑ BR: Connection terminal for the braking resistor. Not available for 1.6 A, 2.6 A and 4 A/200-240 V and 1.6 A and 2.6 A/110-127 V and 7.3 A/200-240 V three-phase models.
- ☑ +UD: Positive connection terminal (DC Link). This terminal is used to connect the braking resistor (connect also the BR terminal). Not available for 1.6 A, 2.6 A and 4.0 A/200-240 V and 1.6 A and 2.6 A/110-127 V and 7.3 A/200-240 V three-phase models.

a) Models 1.6 A, 2.6 A and 4.0 A/200-240 V and 1.6 A and 2.6 A/110-127 V (single-phase)

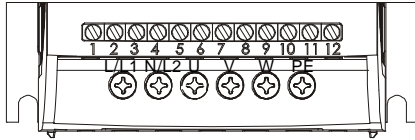

b) Models 7.3 A and 10 A/200-240 V and 4.0 A/110-127 V (single-phase)

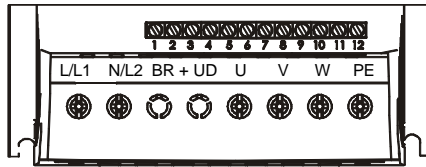

c) Models 1.6 A, 2.6 A, 4.0 A, 7.3 A/200-240 V (three-phase)

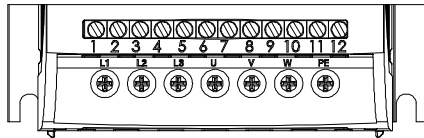

d) Models 10.0 A and 15.2 A/200-240 V (three-phase)

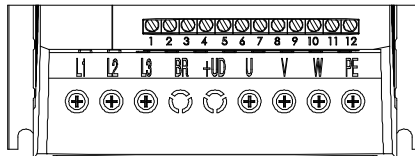

Figure 3.4 a) b) c) d) - CFW-10 Power Terminals

3.2.2 Location of the Power, Grounding and Control Connections

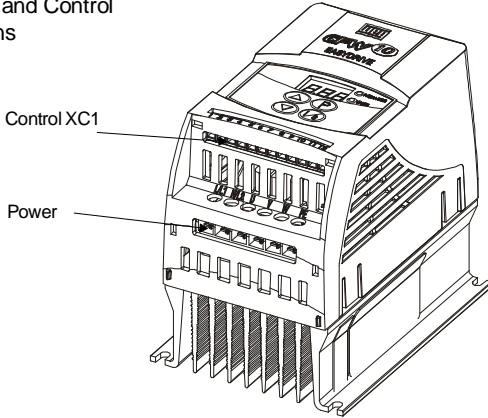

Figure 3.5 - Location of the Power and Control Connections

3.2.3 Wiring and Fuses for Power and Grounding



ATTENTION!

Provide at least 0.25 m (10 in) spacing between low voltage wiring and drive/motor cables. For instance: PLC's, temperature monitoring devices, thermocouples, etc.

Table 3.3 presents minimum cable diameter and circuit breaker rating for the CFW-10. Tightening torque shall be as indicated in table 3.4. All power wiring (copper) shall be rated for 70 °C minimum.

| Rated Inverter Current [A] | Motor Wiring [mm ²] | Grounding Wiring [mm ²] | Power Cables [mm ²] | Maximum Cables [mm ²] | Circuit-Breaker | |
|----------------------------|---------------------------------|-------------------------------------|---------------------------------|-----------------------------------|-----------------|-----------|
| | | | | | Current | WEG Model |
| SINGLE-PHASE MODELS | | | | | | |
| 1.6 (200-240 V) | 1.5 | 2.5 | 1.5 | 2.5 | 6 | MPW25-6.3 |
| 1.6 (110-127 V) | 1.5 | 2.5 | 1.5 | 2.5 | 10 | MPW25-10 |
| 2.6 (200-240 V) | 1.5 | 2.5 | 1.5 | 2.5 | 10 | MPW25-10 |
| 2.6 (110-127 V) | 1.5 | 2.5 | 2.5 | 2.5 | 16 | MPW25-16 |
| 4.0 (200-240 V) | 1.5 | 2.5 | 1.5 | 2.5 | 16 | MPW25-16 |
| 4.0 (110-127 V) | 1.5 | 4.0 | 2.5 | 4.0 | 20 | MPW25-20 |
| 7.3 (200-240 V) | 2.5 | 4.0 | 2.5 | 4.0 | 20 | MPW25-20 |
| 10.0 (200-240 V) | 2.5 | 4.0 | 4.0 | 4.0 | 25 | MPW25-25 |
| THREE-PHASE MODELS | | | | | | |
| 1.6 (200-240 V) | 1.5 | 2.5 | 1.5 | 2.5 | 2.5 | MPW25-2.5 |
| 2.6 (200-240 V) | 1.5 | 2.5 | 1.5 | 2.5 | 6.3 | MPW25-6.3 |
| 4.0 (200-240 V) | 1.5 | 2.5 | 1.5 | 2.5 | 10 | MPW25-10 |
| 7.3 (200-240 V) | 2.5 | 4.0 | 2.5 | 4.0 | 15 | MPW25-15 |
| 10.0 (200-240 V) | 2.5 | 4.0 | 4.0 | 4.0 | 20 | MPW25-20 |
| 15.2 (200-240 V) | 4.0 | 4.0 | 4.0 | 4.0 | 25 | MPW25-25 |

Table 3.3 - Recommended wire cross-section and circuit-breakers - use (70 °C) copper wires only



NOTE!

Cable dimensions indicated in table 3.3 are reference values only. Installation conditions and the maximum acceptable line voltage drop shall be considered when sizing the power cables.

| Model | Power Cables | |
|--------------------|--------------|--------|
| | N.m | Lbf.in |
| SINGLE-PHASE | | |
| 1.6 A / 200-240 V | 1.0 | 8.68 |
| 2.6 A / 200-240 V | 1.0 | 8.68 |
| 4.0 A / 200-240 V | 1.0 | 8.68 |
| 7.3 A / 200-240 V | 1.76 | 15.62 |
| 10.0 A / 200-240 V | 1.76 | 15.62 |
| 1.6 A / 110-127 V | 1.0 | 8.68 |
| 2.6 A / 110-127 V | 1.0 | 8.68 |
| 4.0 A / 110-127 V | 1.76 | 15.62 |
| THREE-PHASE | | |
| 1.6 A / 200-240 V | 1.0 | 8.68 |
| 2.6 A / 200-240 V | 1.0 | 8.68 |
| 4.0 A / 200-240 V | 1.0 | 8.68 |
| 7.3 A / 200-240 V | 1.0 | 8.68 |
| 10.0 A / 200-240 V | 0.5 | 4.4 |
| 15.2 A / 200-240 V | 0.5 | 4.4 |

Table 3.4 - Recommended tightening torques for power connections

3.2.4 Power Connections

a) Models 1.6 A, 2.6 A and 4.0 A/200-240 V and 1.6 A and 2.6 A/110-127 V (single-phase)

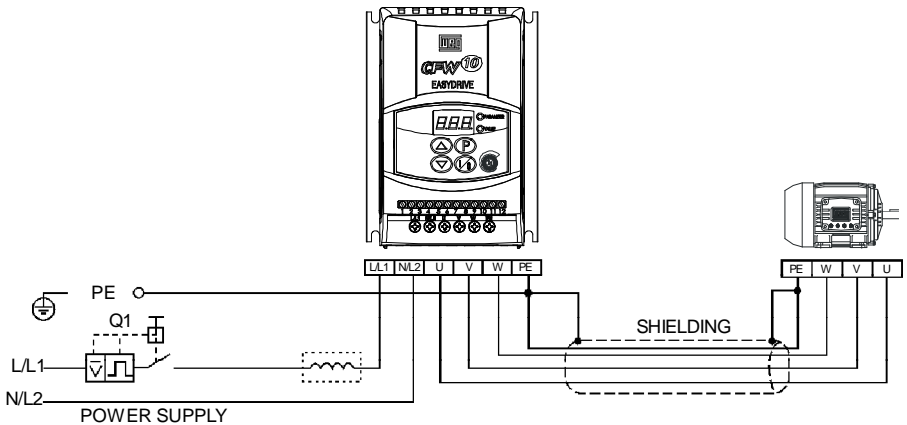
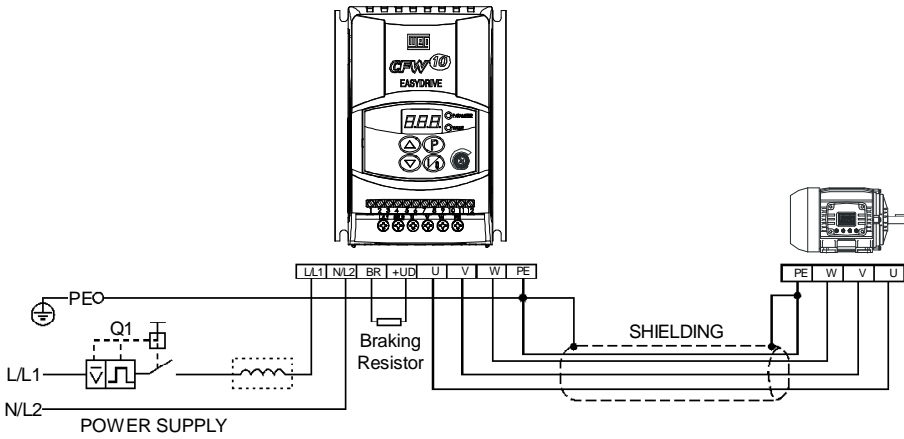

Figure 3.6 a) - Grounding and power supply connections

CHAPTER 3 - INSTALLATION AND CONNECTION

b) Models 7.3 A to 10 A/200-240 V and 4.0 A/110-127 V (single-phase)



c) Models 1.6 A, 2.6 A, 4.0 A and 7.3 A/200-240 V (three-phase)

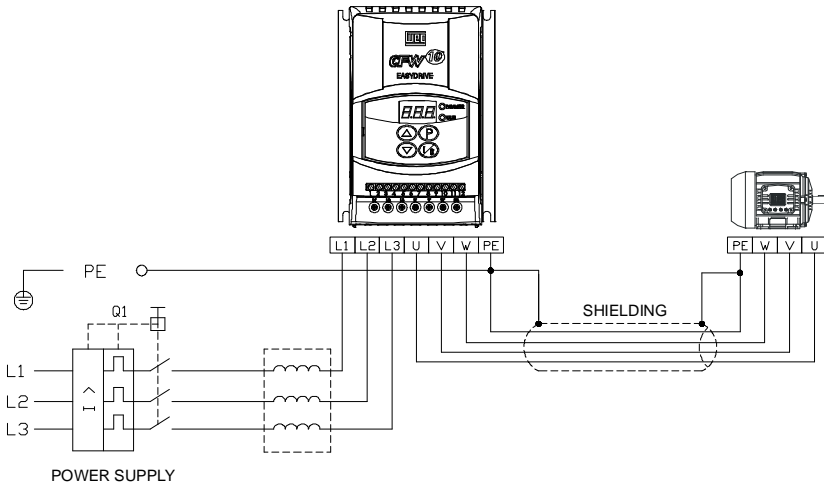

Figure 3.6 b) c) - Grounding and power supply connections

d) Models 10.0 A and 15.2 A/200-240 V (three-phase)

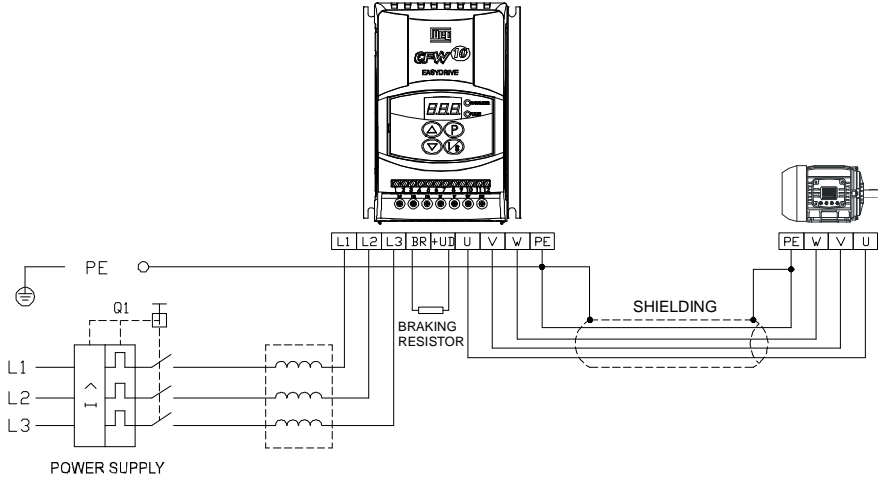

Figure 3.6 d) - Grounding and power supply connections

3.2.4.1 AC Input Connection



DANGER!

Use a disconnecting device at the drive AC-input power supply. This device shall be capable of disconnecting the drive from the power supply when necessary (for maintenance purposes, for instance).



ATTENTION!

The drive AC-input power supply shall have a grounded neutral conductor.



NOTE!

The AC-input voltage shall match the drive rated voltage.

Supply line capacity:

- ☑ The CFW-10 is capable of withstanding up to 30.000 symmetrical rms Amperes at 127 V/240 V.
- ☑ If the CFW-10 is installed in networks with higher symmetrical rms currents (> 30.000 Amps), an appropriate protection mean shall be provided (fuses or circuit breaker).

Line Reactors

The use of line reactors is dependent upon several factors. Refer to Chapter 8.2 in order to understand these requirements.



NOTE!

Capacitors for power factor correction are not required at the input (L/L1, N/L2, L3) and shall not be connected at the output (U, V, W).

3.2.4.2 Output Connection

The drive has electronic protection against motor overload. This protection shall be set according to the specific motor. When the same drive is connected to several motors, individual overload relays shall be used for each motor protection.



ATTENTION!

If a disconnecting switch or a contactor is inserted between the drive output and the motor input, do not operate them when motor is running or when drive is enabled. Maintain the electrical continuity of the motor cable shield.

Rheostatic Braking

For the drives with the rheostatic braking optional, the braking resistor shall be installed externally. Refer to figure 8.4 for correct braking resistor installation. Size the braking resistor according to the application and respecting the maximum admissible current for the braking circuit.

Use twisted pair to connect the braking resistor to the drive. Run this cable separately from the signal and control cables. If the braking resistor is installed inside the drive panel, the additional resistor heat dissipation shall be considered when defining the panel ventilation.

3.2.4.3 Grounding Connections



DANGER!

The drive must be grounded for safety purposes (PE). The ground connection must comply with the local regulations. For grounding purposes, use cables with cross sections as indicated in table 3.3. Make the ground connection to a grounding bar or to the general grounding point (resistance ≤ 10 ohms).



DANGER!

The grounding wiring shall be installed away from equipment operating with high currents (for instance: high voltage motors, welding machines, etc).

If several drives are used together, refer to figure 3.7.

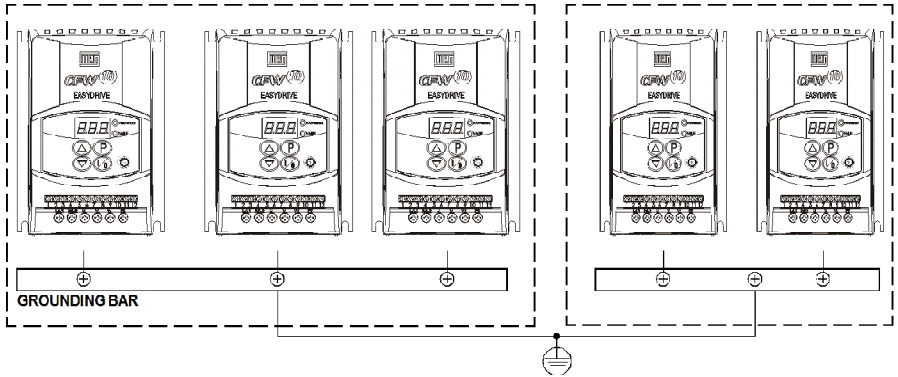

Figure 3.7 - Grounding connections for more than one drive



NOTE!

Do not use the neutral conductor for grounding purposes.



ATTENTION!

The AC input for the drive supply must have a grounded neutral conductor.

Electromagnetic Interference (EMI)

Shielded cable or metallic conduit shall be used for motor wiring when electromagnetic interference (EMI) caused by the drive interferes in the performance of other equipment. Connect one end of the shielding to the drive grounding point and the other end to the motor frame.

Motor Frame

Always ground the motor frame. Ground the motor in the panel where the drive is installed or ground it to the drive. The drive output wiring must be laid separately from the input wiring as well as from the control and signalcables.

3.2.5 Signal and Control Connections

The signal (analog input) and control connections (digital inputs and relay output) are made on the XC1 connector of control board (see location in figure 3.5).

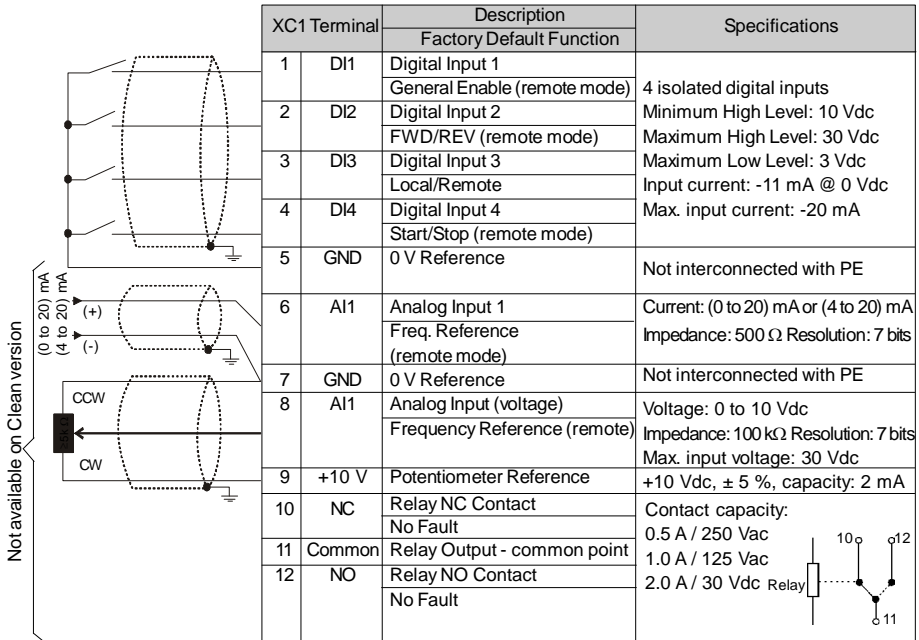

Figure 3.8 - Description of the XC1 terminal of the control board



NOTE!

- ☑ If the input current from (4 to 20) mA is used as standard, do not forget to set the Parameter P235 which defines the signal type at AI1.
- ☑ The analog input AI1 and the Relay output, (XC1:6...12) are not available on Clean version of the CFW-10.

During the signal and control wire installation note the following:

- 1) Cable cross section: (0.5 to 1.5) mm² / (20 to 14) AWG.
- 2) Max. Torque: 0.50 N.m (4.50 lbf.in).
- 3) XC1 wiring must be connected with shielded cables and installed at least 10 cm (3.9 in) minimum separately from other wiring (power, control at 110/220 V, etc) for lengths up to 100 m (330 ft) and 25 cm (9.8 in) minimum for total lengths over 100 m (330 ft).
If the crossing of these cables is unavoidable, install them perpendicular, maintaining a minimum separation distance of 5 cm (2 in) at the crossing point.

Connect the shield as shown below:

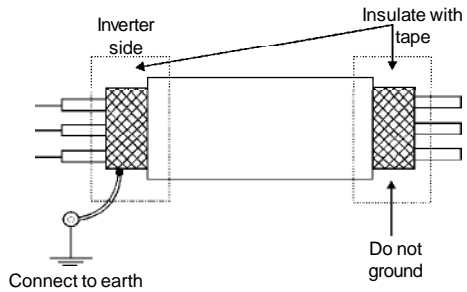

Figure 3.9 - Shield connection

- 4) For wiring distances longer than 50 m (150 ft), the use of galvanic isolators is required for the XC1:6 to XC1:9 analog signals.
- 5) Relays, contactors, solenoids or eletromagnetic braking coils installed near inverters can eventually generate interferences in the control circuit. To eliminate this interference, connect RC suppressor in parallel with the coils of AC relays. Connect free-wheeling diode in case of DC relays.
- 6) **When analog reference (AI1) is used and the frequency oscillates (problem caused by electromagnetic interference) connect XC1:7 to the inverter grounding bar.**

3.2.6 Typical Terminal Connections

Connection 1

With the **factory default programming**, it is possible to operate the inverter in **local mode** with the minimum connections shown in figure 3.6 (Power) and without control connections. This operation mode is recommended for users who are operating the inverter for the first time as initial learning about equipment. Note that any connection is needed on control terminal.

For start-up according to this operation mode, refer to Chapter 5.

Connection 2

Command enabling via terminals.

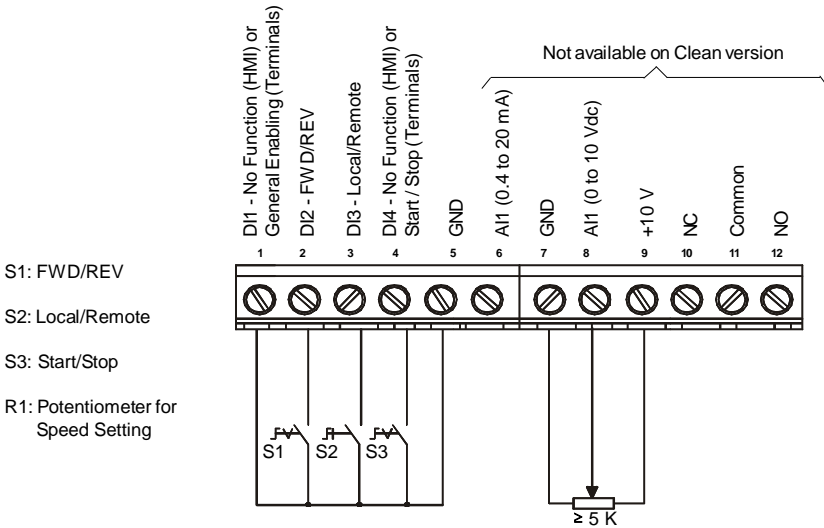

Figure 3.10 - Wiring for Connection 2



NOTE!

- ☑ The frequency reference can be sent via AI1 analog input (as shown in figure above), via keypad HMI-CFW 10, or via any other source (see description of Parameters P221 and P222).
- ☑ When a line fault occurs by using this type of connection with switch S3 at position "RUN", the motor will be enabled automatically as soon as the line is re-established.
- ☑ Function 2 configuration is not possible on CFW-10 Clean version.

Connection 3

Start/Stop function enabling (three-wire control):

Set DI1 to Start: P263 = 13

Set DI2 to Stop: P264 = 14

Set P229 = 1 (commands via terminals) if you want the 3-wire control in local mode.

Set P230 = 1 (commands via terminals) if you want the 3-wire control in remote mode.

FWD / REV Selection:

Program P265 = 5 (DI3) or P266 = 5 (DI4), according to the selected digital input (DI).

If P265 and P266 ≠ 0, the direction of rotation is always FWD.

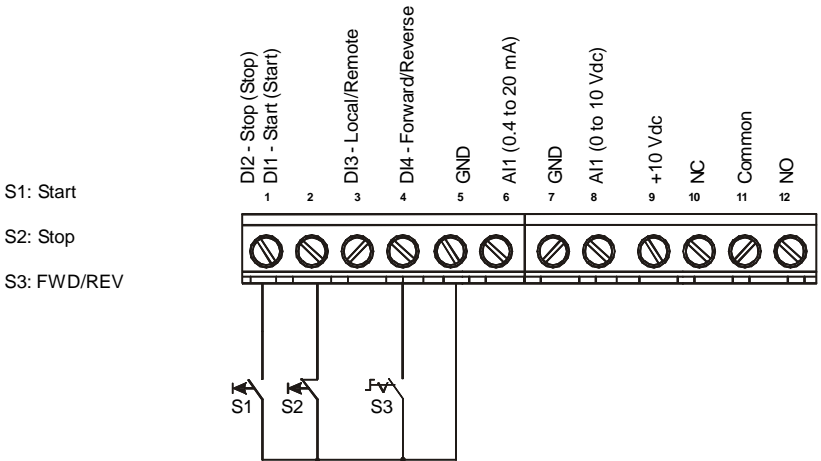

Figure 3.11 - Wiring for Connection 3



NOTE!

- ☑ S1 and S2 are push buttons, NO and NC contact, respectively.
- ☑ The speed reference can be realized via Analog Input AI1 (as in connection 2), via keypad (HMI-CFW 10), or via any other source (See description of parameters P221 and P222).

When a line fault occurs by using this connection with the motor running and the S1 and S2 switches are in original position (S1 opened and S2 closed), the inverter will not be enabled automatically as soon as the line is re-established.

The drive will be enabled only when S1 switch is closed. (Pulse on the "Start" digital input).

The Start/Stop function is described in Chapter 6.

Connection 4

Enabling of the FWD/REV function:

Set DI1 to Forward Run : P263 = 9

Set DI2 to Reverse Run : P264 = 10

Make sure the inverter commands are via terminals, i.e., set P229 = 1 to local mode.

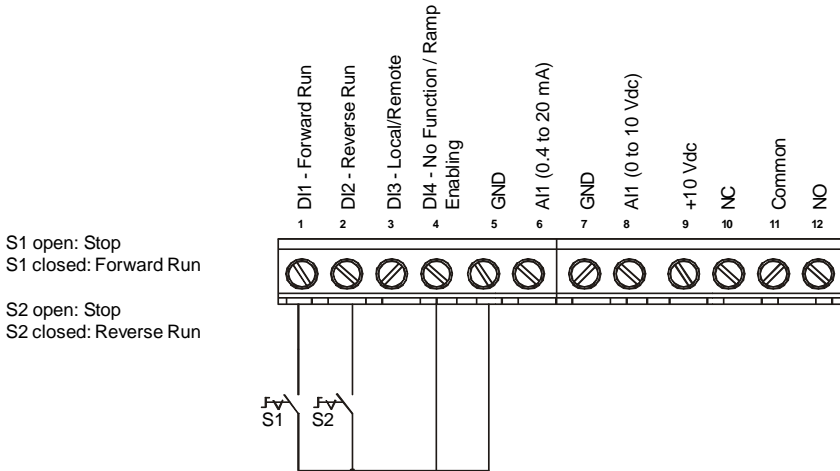

Figure 3.12 - Wiring for Connection 4



NOTE!

- ☑ The speed reference can be realized via Analog Input AI1 (as in connection 2), via keypad (HMI), or via any other source (see description of parameters P221 and P222).
- ☑ When a line fault occurs in this connection mode with switch S1 or switch S2 is closed, the motor will be enabled automatically as soon as the line is re-established.

3.3 European EMC Directive - Requirements for Conforming Installations

The CFW-10 inverter series was designed considering all safety and EMC (ElectroMagnetic Compatibility) aspects.

The CFW-10 units do not have an intrinsic function until connected with other components (e. g. a motor). Therefore, the basic product is not CE marked for compliance with the EMC Directive. The end user takes personal responsibility for the EMC compliance of the whole installation. However, when installed according to the recommendations described in the product manual and including the recommended filters and EMC measures the CFW-10 fulfill all requirements of the (EMC Directive 89/336/EEC) as defined by the **EN61800-3 "EMC Product Standard for Adjustable Speed Electrical Power Drive Systems** - specific standard for variable speed drives.

The conformity of the complete CFW-10 series is based on tests performed on sample models. A Technical Construction File (TCF) was prepared, checked and approved by a Competent Body.

3.3.1 Installation

Figure 3.13 below shows the EMC filters connection.

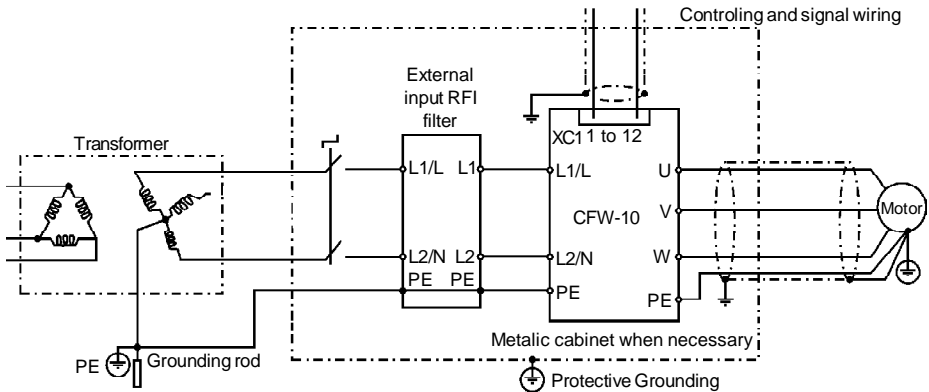

Figure 3.13 - EMC filter connection - general condition

The following items are required in order to have an appropriated installation:

- 1) The motor cable shall be armored, or installed inside a metallic conduit or trunking with equivalent attenuation. Ground the screen/metallic conduit at both ends (inverter and motor).
- 2) Control (I/O) and signal wiring shall be shielded or installed inside a metallic conduit or trunking with equivalent attenuation, as possible.
- 3) The inverter and the external filter shall be closely mounted on a common metallic back plate. Ensure a good electrical connection between the inverter heatsink, the filter frame and the back plate.
- 4) The wiring between the filter and the inverter shall be kept as short.
- 5) The cable shield (motor and control) shall be solidly connected to the common back plate, using metallic brackets.
- 6) Grounding shall be performed as recommended in this user's guide.
- 7) Use short and thick cables to ground the external filter or inverter. When an external filter is used, ground only the filter (input) - the inverter ground connection is performed through the metallic back plate.
- 8) Ground the back plate using a braid, as short as possible. Flat conductors (e.g. braids or brackets) have lower impedance at high frequencies.
- 9) Use cable glands whenever possible.

3.3.2 Specification of the Emission and Immunity Levels

| EMC phenomenon | Basic standard for test method | Level |
|---|--------------------------------|--|
| Emission: | | |
| Conducted emissions (mains terminal disturbance voltage - freq band 150 kHz to 30 MHz) | IEC/EN61800-3 | "First environment" ⁽¹⁾ , restricted distribution ⁽³⁾ Class B, or; "First environment" ⁽¹⁾ , restricted distribution ⁽⁴⁾⁽⁵⁾ Class A1, or; "Second environment" ⁽²⁾ , unrestricted distribution ⁽³⁾⁽⁶⁾ Classe A2 Note: It depends on the drive model and on the motor cable length (Refer to table 3.5.2). |
| Radiated emissions (electromagnetic radiation disturbance - freq band 30 MHz to 1000 MHz) | | "First environment" ⁽¹⁾ , restricted distribution ⁽⁴⁾⁽⁵⁾ |
| Immunity: | | |
| Electrostatic discharge (ESD) | IEC 61000-4-2 | 6 kV contact discharge |
| Fast Transient-Burst | IEC 61000-4-4 | 4 kV/2.5 kHz (capacitive clamp) input cable; 2 kV/5 kHz control cables; 2 kV/5 kHz (capacitive clamp) motor cable; |
| Conducted radio-frequency common mode | IEC 61000-4-6 | 0.15 to 80 MHz; 10 V; 80 % AM (1 kHz) - motor control and remote Keypad cable HMI Remote |
| Surge | IEC 61000-4-5 | 1.2/50 µs, 8/20 µs; 1 kV coupling line to line; 2 kV coupling line to earth |
| Radio-frequency electromagnetic field | IEC 61000-4-3 | 80 to 1000 MHz; 10 V/m; 80 % AM (1 kHz) |

Notes:

- (1) "First environment": environment that includes domestic premises. It also includes establishments directly connected without intermediate transformers to a low-voltage power supply network which supplies buildings used for domestic purposes.
- (2) "Second environment": environment that includes all establishments other than those directly connected to a low-voltage power supply network which supplies buildings used for industrial purposes.
- (3) Unrestricted distribution: mode of sales distribution in which the supply of equipment is not dependent on the EMC competence of the customer or user for the application of drives.
- (4) Restricted distribution: mode of sales distribution in which the manufacturer restricts the supply of equipment to suppliers, customers or users who separately or jointly have technical competence in the EMC requirements of the application of drives. (source: these definitions were extracted from the product standard IEC/EN61800-3 (1996) + A11 (2000))

- (5) For installation in residential environments with conducted emission level Class A1 (according to table 3.5.2), please, consider the following:
This is a product of restricted sales distribution class according to the product standard IEC/EN61800-3 (1996) + A11 (2000). In a domestic environment this product may cause radio interference in which case the user may be required to take adequate measures.
- (6) When installing drives that meet Class A2 for conducted emission level, i.e. industrial environment and unrestricted distribution (according to table 3.5.2), observe the following:
This product is specifically designed for use in industrial low-voltage power supply networks (public networks) that not supply residential buildings. This product may cause radio frequency interference in a domestic environment.

3.3.3 Inverter and Filters

Table 3.5.2 shows the inverter models, its respective EMC filter and the EMC category classification. Refer to section 3.3.2 for EMC category description and to section 3.3.4 for external filters characteristics.

| Inverter Model with Built-in EMC Filter (single-phase) | EMC Class |
|--|---|
| 1.6 A / 200-240 V | Class A1. Maximum motor cable length 7 meters (22.9 ft) . |
| 2.6 A / 200-240 V | |
| 4.0 A / 200-240 V | Class A2. Maximum motor cable length 50 meters (164 ft) . Switching frequency ≤ 5 kHz. |
| 7.3 A / 200-240 V | |
| 10.0 A / 200-240 V | |

Table 3.5.1 - List of frequency drive models, EMC filters and EMC categories

| Inverter Model (single-phase) | Input RFI Filter | EMC Class |
|-------------------------------|---|---|
| 1.6 A / 200-240 V | Footprint / Booksize Model: B84142A0012R212 (EPCOS) Standard Model: B84142-A20-R (EPCOS) | Class A1. Maximum motor cable length is 30 meters (98.4 ft) . Class A2. Maximum motor cable length is 50 meters (164 ft) . Class B. Maximum motor cable length is 5 meters (16.4 ft) . |
| 2.6 A / 200-240 V | | |
| 4.0 A / 200-240 V | | |
| 1.6 A / 110-127 V | | |
| 2.6 A / 110-127 V | | |
| 7.3 A / 200-240 V | Footprint / Booksize Model: B84142B18R212 (EPCOS) | Class A1. Maximum motor cable length is 30 meters (98.4 ft) . Class A2. Maximum motor cable length is 50 meters (164 ft) . Class B. Maximum motor cable length is 5 meters (16.4 ft) . |
| 4.0 A / 110-127 V | | |
| 7.3 A / 200-240 V | (EPCOS) Standard Model: B84142-A20-R (EPCOS) | Class A1. Maximum motor cable length is 25 meters (82 ft) . Class A2. Maximum motor cable length is 40 meters (131.2 ft) . Class B. Maximum motor cable length is 5 meters (16.4 ft) . |
| 4.0 A / 110-127 V | | |
| 10.0 A / 200-240 V | Footprint / Booksize Model: B84142B22R212 (EPCOS) | Class A1. Maximum motor cable length is 30 meters (98.4 ft) . Class A2. Maximum motor cable length is 40 meters (131.2 ft) . Class B. Maximum motor cable length is 5 meters (16.4 ft) . |
| 10.0 A / 200-240 V | Standard Model: B84142-A30-R (EPCOS) | Class A1. Maximum motor cable length is 30 meters (98.4 ft) . Class A2. Maximum motor cable length is 50 meters (164 ft) . Class B. Maximum motor cable length is 3 meters (9.8 ft) . |

Note: Maximum switching frequency is 5 kHz.

Table 3.5.2 - List of frequency drive models, EMC filters and EMC categories



NOTE!

The CFW-10 inverters with three-phase supply do not have EMC filters.

3.3.4 Characteristics of the EMC Filters

Footprint / Booksize Model B84142A0012R212 (EPCOS)

Supply voltage: 250 V, 50/60 Hz

Current: 12 A

Weight: 0.95 Kg (2.1 lb)

a) Model footprint/booksize B84142A0012R212 (EPCOS)

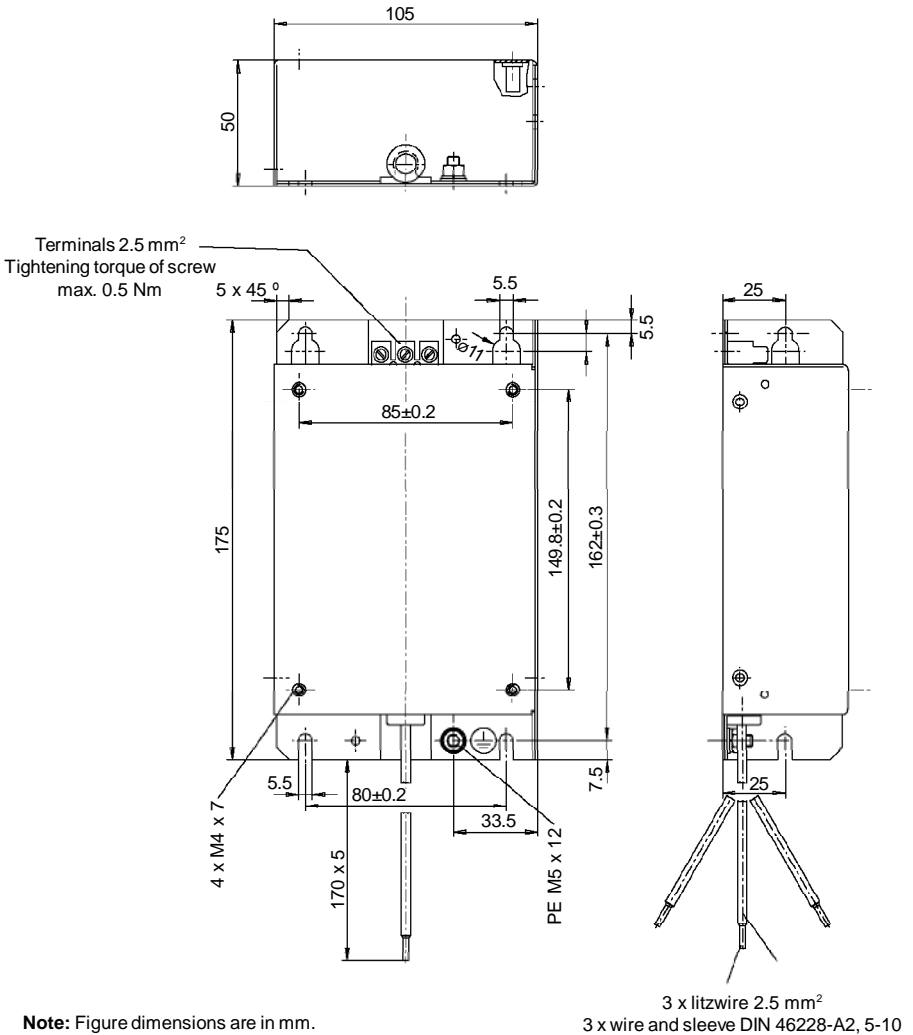

Figure 3.14 a) - Drawing of the footprint / bookside filter

CHAPTER 3 - INSTALLATION AND CONNECTION

Footprint / booksize Model B84142B18R212 (EPCOS)

Supply Voltage: 250 V, 50/60 Hz

Current: 18 A

Weight: 1.3 kg (2.9 lb)

b) Footprint/booksize model B84142B18R212 (EPCOS)

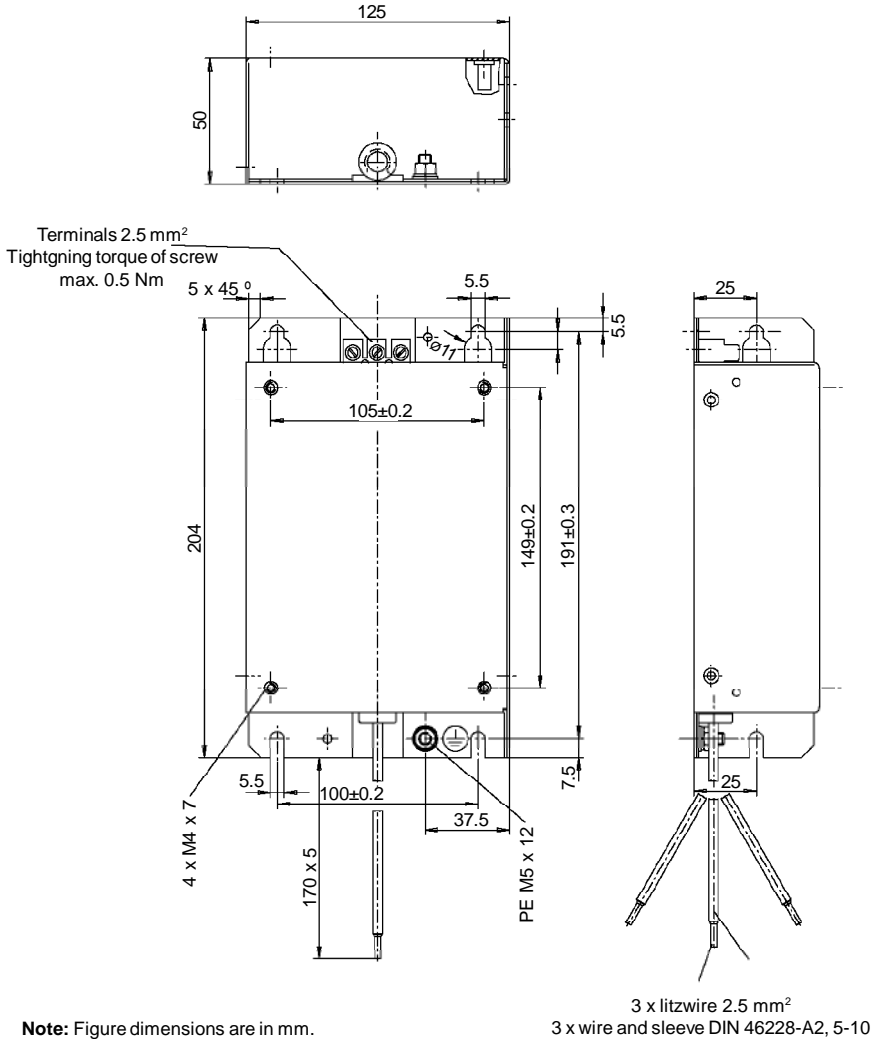

Note: Figure dimensions are in mm.

Figure 3.14 b) - Drawing of the footprint / booksize filter

Footprint / booksize Model B84142B22R212 (EPCOS)
 Supply voltage: 250 V, 50/60 Hz
 Current: 22 A
 Weight: 1.4 kg (3 lb)

c) Footprint/booksize Model B84142B22R212 (EPCOS)

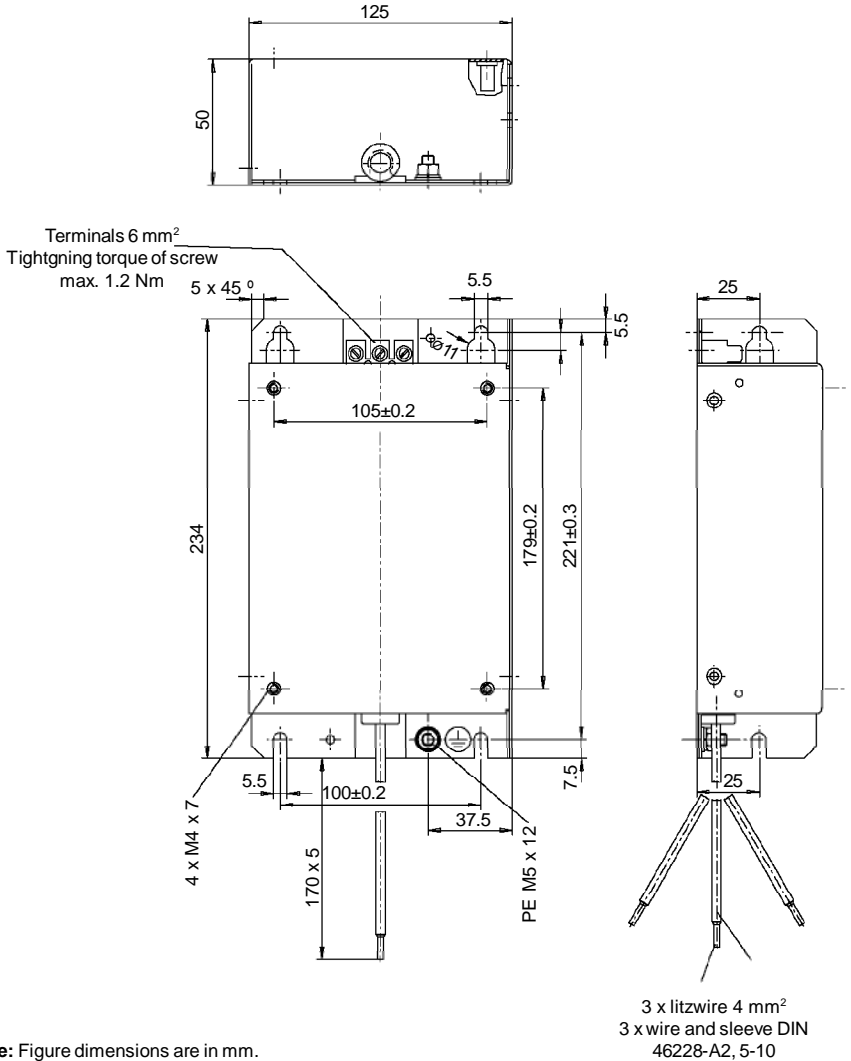

Note: Figure dimensions are in mm.

Figure 3.14 c) - Drawing of the footprint / booksize filter

CHAPTER 3 - INSTALLATION AND CONNECTION

Standard Model: B84142 - A20-R

Supply voltage: 250 V, 50/60 Hz

Current: 20 A

Weight: 1 kg (2.2 lb)

a) Standard Model: B84142-A20-R (EPCOS)

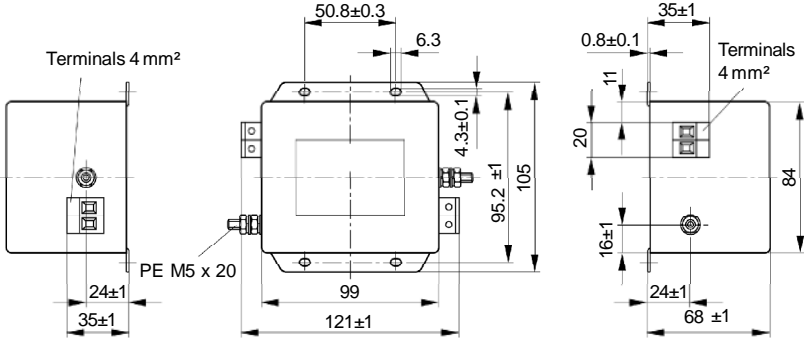

Note: Figure dimensions are in mm.

Standard Model: B84142 - A30-R

Supply voltage: 250 V, 50/60 Hz

Current: 30 A

Weight: 1 kg (2.2 lb)

b) Standard Model: B84142-A30-R (EPCOS)

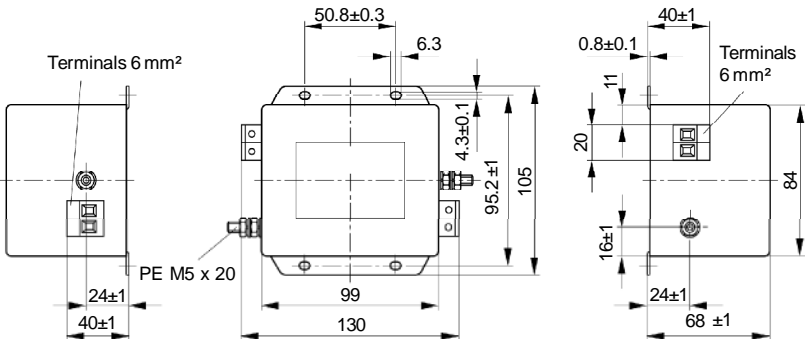

Note: Figure dimensions are in mm.

Figure 3.15 a) b) - Drawing of the Standard Filter



NOTE!

The declaration of conformity CE is available on the website www.weg.net or on the CD, which comes with the products.

KEYPAD (HMI) OPERATION

This chapter describes the CFW-10 operation via Human-Machine Interface (HMI), providing the following information:

- ☑ General keypad description (HMI);
- ☑ Use of the keypad (HMI);
- ☑ Inverter parameters arrangement;
- ☑ Alteration mode parameters (programming);
- ☑ Description of the status indicators.

4.1 KEYPAD (HMI) DESCRIPTION

The standard CFW-10 keypad has a LED display with 3 digits of 7 segments, 2 status LEDs and 4 keys. Figure 4.1 shows the front view of the keypad and indicates the position of the Display and the status LEDs. CFW-10 Plus version still has a potentiometer for speed setting.

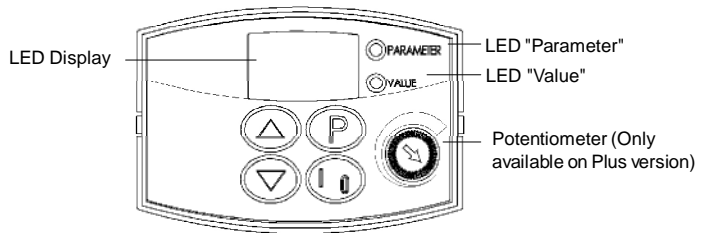

Figure 4.1 - CFW-10 keypad (HMI)

Functions of the LED Display:

The Led Display shows the fault and status messages (see Quick Parameter Reference, Fault and Status), the parameter number and its value.

Functions of the LED's "Parameter" and "Value":





Inverter indicates the parameter number:
Green Led OFF and red Led ON.

Inverter indicates the parameter content:
Green Led ON and red Led OFF.

Potentiometer Function



Increase/Decrease the speed (only available on Plus version)

Basic Functions of the Keys:

-  Enables/disables the inverter via acceleration/deceleration ramp (run/stop). Resets the inverter after a fault trip.
-  Selects (commutates) the display between parameter number/value (position/content).
-  Increases the frequency, the parameter number or the parameter value.
-  Decreases the frequency, the parameter number or the parameter value.

4.2 USE OF THE KEYPAD (HMI)

The Keypad (HMI) is a simple interface that allows inverter operation/programming. This interface has the following functions:

- Indication of the inverter status and operation variables;
- Fault indication and diagnostics;
- Viewing and programming parameters;
- Inverter operation (key ) and speed reference setting (keys  and 
- Potentiometer for the output frequency variation (only in the Plus version).

4.2.1 Keypad (HMI) Operation

All functions relating to the CFW-10 operation (Start/Stop, Increment/Decrement of the Speed Frequency) can be performed through the HMI selection. For factory default programming of the inverter, all keypad keys are enabled. These functions can be carried out through digital and analog inputs. Thus you must program the parameters related to these corresponding inputs.



NOTE!

The command key  will be enabled only when:





- P229 = 0 for LOCAL Mode operation
- P230 = 0 for REMOTE Mode operation

See below the keypad functions description:





When pressed, motor accelerates according to acceleration ramp up to the speed (frequency) reference. The function is similar to that performed through digital input START/STOP, when it is closed (enabled) and maintained enabled.

When pressed again, inverter is disabled via ramp (motor accelerates according to acceleration ramp and stops). The function is similar to that performed through digital input START/STOP, when it is opened (disabled) and maintained disabled.

-  and  Motor speed (frequency) setting: these keys are enabled for speed setting only when:
- The speed reference source is the keypad (P221 = 0 for LOCAL Mode and/or P222 = 0 for REMOTE Mode);
 - The following parameter content is displayed: P002, P005 or P121. Parameter P121 stores the speed reference set by these keys.
-  When pressed, it increases the speed (frequency) reference.
-  When pressed, it decreases the speed (frequency) reference.

Reference Backup

The last frequency reference, set by the keys the  and , is stored when inverter is stopped or the AC power is removed, provided P120 = 1 (reference backup active is the factory default). To change the frequency reference before inverter is enabled, you must change the value of the parameter P121.



NOTE!

On CFW-10 Plus version, the motor frequency setting function is made through the HMI potentiometer. However, it is possible to set the motor frequency through the keys since P221/P222 parameters were programmed.

4.2.2 Inverter Status - HMI Display

Inverter status:



Inverter is READY to be started.



Line voltage is too low for inverter operation (undervoltage condition).



Inverter is in a Fault condition. Fault code is flashing on the display. In our example we have the fault code E02 (refer to chapter 7).



Inverter is applying a DC current on the motor (DC braking) according to the values programmed at P300, P301 and P302 (refer to chapter 6).



Inverter is running self-tuning routine to identify parameters automatically. This operation is controlled by P204 (refer to chapter 6).



NOTE!

Besides the fault conditions, the display also flashes when the inverter is in overload condition (refer to chapter 7).

CHAPTER 4 - KEYPAD (HMI) OPERATION

- 4.2.3 Read-Only Variables Parameters from P002 to P008 are reserved for the display of read-only variables.
When the inverter is powered up, the display will indicate the value of the Parameter P002 (output frequency value).
- 4.2.4 Parameter Viewing and Programming All inverter settings are made through parameters. Parameters and their contents are shown on the Display through the LED's "Parameter" and "Value". The identification is made between parameter number and its value.
Example (P100):

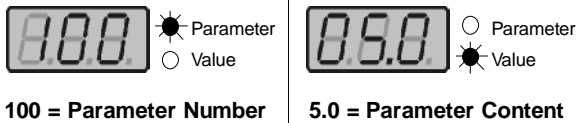

Each parameter is associated with a numerical value (parameter value), that corresponds to the selected option among the available ones for this parameter.



The parameter values define the inverter programming or the value of a variable (e.g.: current, frequency, voltage). For inverter programming you should change the parameter content(s).

To allow the reprogramming of any parameter value it is required to set P000 = 5. Otherwise you can only read the parameter values, but not reprogram them. For more details, see P000 description in Chapter 6.

| ACTION | HMI DISPLAY | DESCRIPTION |
|----------------------|-------------|--|
| Turn ON the inverter | | Inverter is ready to be started |
| Use the keys and | | Select the desired parameter |
| Press the key | | Numerical value associated with the parameter ⁽⁴⁾ |
| Use the keys and | | Set the new desired value ⁽¹⁾⁽⁴⁾ |
| Press the key | | ^{(1) (2) (3)} |



NOTE!

- (1) For parameters that can be changed with the running motor, the inverter will use the new value immediately after it has been set. For parameters that can be changed only with stopped motor, the inverter will use this new value only after the key  is pressed.
- (2) By pressing the  key after the reprogramming, the new programmed value will be saved automatically in the volatile memory and will remain stored there until a new value is programmed.
- (3) If the last programmed value in the parameter is not functionally compatible with the other parameter values already programmed, the E24 = Programming Error - will be displayed.
 Example of programming error:
 Programming of two digital inputs (DI) with the same function. Refer to table 4.1 for list of programming errors that can generate an E24 Programming Error.
- (4) To change any parameter value, you must set before P000 = 5. Otherwise you can only read the parameter values, but not reprogram them. For more details, see P000 description in Chapter 6.

| |
|---|
| If one DI has been set to JOG (P263 to P266 = 3) and no other DI has been set to General Enable or Ramp (P263 to P266 ≠ 1 or 2 or 4 or 9 or 13). |
| Two or more DI(s) programmed to the same value (P263 to P266 = 3 to 6.9 to 26). |
| In one DI has been set to FWD (P263 to P266 = 9 or 11) and no other DI has been set to REV (P263 to P266 = 10 or 12). |
| One DI programmed to ON (P263 to P266 = 13) and no other DI has been set to OFF (P263 to P266 = 14). |
| One DI programmed to Accelerate (P263 to P266 = 16 or 18) and no other DI has been set to Decelerate (P263 to P266 = 17 or 19). |
| DI(s) programmed to the function FWD/REV (P263 to P266 = [9 or 11] and [10 or 12]), and simultaneously other DI(s) have been programmed to the functions ON/OFF (P263 to P266 = 13 and 14). |
| Reference programmed to Multispeed (Local or Remote - P221 and/or P222 = 6) and there are no DI(s) programmed to Multispeed (P263 to P266 = 7 or 8). |
| Reference programmed to EP (Local or Remote - P221 and/or P222 = 2) and there are no DI(s) programmed to Accelerate/Decelerate EP (P263 to P266 = 16 to 19). |
| There is command selected to Local and/or Remote (P229 and/or P230 = 1) and there is no DI programmed to General Enable or Ramp or FWD/REV or ON/OFF (P263 to P266 = 1, 2, 4, 13, 14, 9, 10). |
| The DI1 and the DI2 (P263 and P264 = 7 or 8) have been programmed simultaneously to Multispeed. |
| If one DI has been programmed to accelerate EP/on (P263 to P266 = 22) and no other DI has been programmed to decelerate EP/off (P263 to P266 = 23). |
| Reference programmed to local or remote frequency input (P221 and/or P222 = 7) and there is no DI programmed to frequency input (P263 to P266 = 26). |
| When the special function (PID) P203 = 1 is programmed and the reference selection is different than (P221 and P222 ≠ 0 or 3). |

Table 4.1 - Incompatibility between Parameters - E24

START-UP

This Chapter provides the following information:

- ☑ How to check and prepare the inverter before power-up;
- ☑ How to power-up and check for proper operation;
- ☑ How to operate the inverter when it is installed according to the typical connections (See Electrical Installation).

5.1 PRE-POWER CHECKS

The inverter shall be installed according to Chapter 3 - Installation and Connection. If the drive project is different from the typical suggested connections, follow the procedures below.



DANGER!

Always disconnect the AC input power before making any connections.

1) Check all connections

Check if the power, grounding and control connections are correct and well tightened.

2) Check the motor

Check all motor connections and verify if its voltage, current and frequency match the inverter specifications.

3) Uncouple the load from the motor

If the motor can not be uncoupled, make sure that the direction of rotation (FWD/REV) can not cause damage to the machine.

5.2 INITIAL POWER-UP

After the inverter has been checked, AC power can be applied:

1) Check the power supply

Measure the line voltage and check if it is within the specified range (rated voltage: - 15 % / + 10 %).

2) Power-up the AC input

Close the input circuit breaker.

3) Check if the power-up has been successful

The keypad display will show:



While the red LED (Parameter) is ON, the green LED (Value) remains OFF. Inverter runs some self-diagnosis routines. If no problems are found, the display shows:



This means that the inverter is ready (rdy = ready) to be operated.

5.3 START-UP



DANGER!

Even after the AC power supply has been disconnected, high voltages may be still present. Wait at least 10 minutes after powering down to allow full discharge of the capacitors.

5.3.1 Start-up Operation via Keypad (HMI)

The sequence below is valid for the connection 1 (refer to Section 3.2.6). Inverter must be already installed and powered up according to Chapter 3 and Section 5.2.

Connections according to figure 3.6.

| ACTION | HMI DISPLAY | DESCRIPTION |
|---|-------------|---|
| Power-up the inverter | | Inverter is ready to be operated |
| Press the key | | Motor accelerates from 0 Hz to 3 Hz* (min. frequency), in the forward (CW) direction of rotation ⁽¹⁾ * 90 rpm for 4 pole motor |
| Press the key and hold it depressed until 60 Hz is reached On Plus version, vary the potentiometer on the HMI | | Motor accelerates up to 60 Hz* ⁽²⁾ * 1800 rpm for 4 pole motor |
| Press key | | Motor decelerates down to 0 rpm ⁽³⁾ . |



NOTE!

The last frequency reference (speed) value set via the and keys is saved.







If you wish to change this value before inverter enabling, change parameter P121 (Keypad Reference).

NOTES:

- (1) If the direction of rotation of the motor is not correct, switch off the inverter. Wait at least for 10 minutes to allow complete capacitor discharge and then swap any two wires at the motor output.
- (2) If the acceleration current becomes too high, mainly at low frequencies, set the torque boost (I x R compensation) at **P136**. Increase/decrease the content of **P136** gradually until you obtain an operation with constant current over the entire frequency range. For the case above, refer to Parameter Description in Chapter 6.
- (3) If E01 fault display occurs during deceleration, increase the deceleration time at **P101 / P103**.

5.3.2 Start-up Operation Via Terminals The sequence below is valid for the Connection 2 (refer to Section 3.2.6). Inverter must be already installed and powered up according to Chapter 3 and Section 5.2.

Connections according to figures 3.6 and 3.10.

| ACTION | HMI DISPLAY | DESCRIPTION |
|---|--|---|
| See Figure 3.10 Switch S1 (FWD/REV) = Open Switch S2 (Local/Remote) = Open Switch S3 (Start/Stop) = Open Potentiometer R1 (Ref.) = Positioned totally to the left (counterclockwise) Power-up inverter |  | Inverter is ready to be operated |
| Close S2 – Local/Remote |  | The command and the reference are commutated to REMOTO condition (via terminals). |
| Close S3 – Start / Stop |  | Motor accelerates from 0 Hz to 3 Hz* (min. frequency), CW direction ⁽¹⁾ * 90 rpm for 4-pole motor The frequency reference is given by the potentiometer R1 |
| Turn potentiometer clockwise until the end |  | Motor accelerates up to the the maximum frequency (P134 = 66 Hz) ⁽²⁾ |
| Close S1 – FWD/REV |  | Motor decelerates ⁽³⁾ down to 0 rpm (0 Hz), reverses the direction of rotation (CW ⇒ CWW) and accelerates up to the maximum frequency (P134 = 66 Hz) |
| Open S3 – Start/Stop |  | Motor decelerates ⁽³⁾ down to 0 rpm |



NOTES!

- (1) If the direction of roation of the motor rotation is not correct, switch off the inverter. Wait 10 minutes to allow a complete capacitor discharge and the swap any two wires at the motor output.
- (2) If the acceleration current becomes too high, mainly at low frequencies, set the torque boost (I x R compensation) at **P136**. Increase/decrease the content of **P136** gradually until you obtain an operation with constant current over the entire frequency range. For the case above, refer to Parameter Description in Chapter 6.
- (3) If E01 fault occurs during deceleration, increase the deceleration time at **P101 / P103**.
- (4) Function 2 configuration is not possible on CFW-10 Clean version.

DETAILED PARAMETER DESCRIPTION

This chapter describes in detail all CFW-10 parameters and functions.

- 6.1 **SYMBOLS** Please find below some symbols used in this chapter:
A_{lx} = Analog input number x.
AO = Analog output.
D_{lx} = Digital input number x.
F* = Frequency reference. This is the frequency value (or alternatively, of speed) that indicates the desired motor speed at the inverter output.
F_e = Input frequency of the acceleration and deceleration ramp.
F_{max} = Maximum output frequency, defined at P134.
F_{min} = Minimum output frequency, defined at P133.
F_s = Output frequency - frequency applied to the motor.
I_{nom} = Rated inverter output current (rms), in Ampères (A). This value is defined in P295.
I_s = Inverter output current.
I_a = Active current at inverter output, i.e., it is the component of the total motor current proportional to active electric power absorbed by the motor.
RLx = Relay output number x.
U_d = DC link voltage in the DC link circuit.
- 6.2 **INTRODUCTION** This section describes the main concepts related to the CFW-10 frequency inverter.
- 6.2.1 **V/F (Scalar) Control** This control mode is based on the constant V/F curve (P202 = 0 - linear V/F curve). Its performance is limited at low frequencies as function of the voltage drop in the stator resistance, that causes a significant magnetic flow reduction in the motor air gap and consequently reducing the motor torque. This deficiency should be compensated by using manual and automatic boost torque (I x R compensations), that are set manually and depend on the user experience.
 In most applications (for instance: centrifugal pumps and fans) the setting of these functions is enough to obtain the required performance.
 In V/F control, the speed regulation, that can be obtained by setting properly slip compensation can be maintained within 1 % to 2 % of the rated speed. For instance, for a 4V pole motor/60 Hz, the minimum speed variation at no load condition and at rated load can be maintained between 18 to 36 rpm.

 There is still a variation of the linear V/F control previously described: The quadratic V/F control.

This control is suitable for applications like centrifugal pumps and fan (loads with quadratic torque x speed characteristics), since it enables a motor loss reduction, resulting in an additional energy saving by using an inverter.

For more details about the V/F control mode, please refer to the description of the parameters P136, P137, P138, P142 and P145.

6.2.2 Frequency Reference Sources

The frequency reference (i.e., the desired output frequency, or alternatively, the motor speed) can be defined in several ways:



- The keypad - digital reference that can be changed through the keypad (HMI), by using the keys  and  (see P221, P222 and P121);
- Analog input - the analog input AI1 (XC1:6 to XC1:9) (see P221, P222 and P234 to P236);
- Multi-speed - up to 8 preset digital references (see P221, P222 and P124 to P131);
- Electronic potentiometer (EP) - another digital reference, its value is defined by using 2 digital inputs (DI1 and DI4) - see P221, P222, P263 and P266;
- HMI Potentiometer – the reference can be changed through the HMI potentiometer (Only available on CFW-10 Plus version).

Figure 6.1 shows through a diagram block the frequency reference definition to be used by the inverter.

The block diagram in figure 6.2 shows the inverter control.

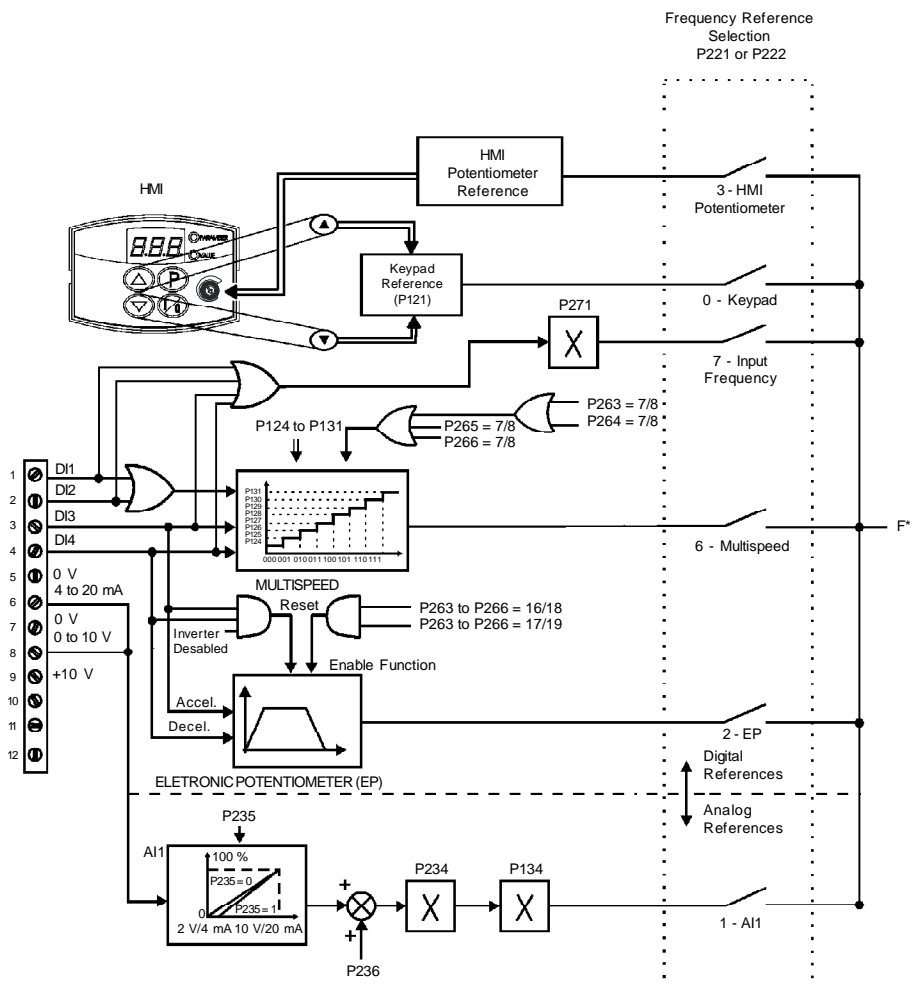

Figure 6.1 - Block diagram of the frequency reference



NOTE!

- ☑ DI5 ON (status 1) when connected to 0 V (XC1:5).
- ☑ When $F^* < 0$ one takes the module of F^* and reverses the direction of rotation (if this is possible - $P231 = 2$ and if the selected control is not forward run/reverse run).

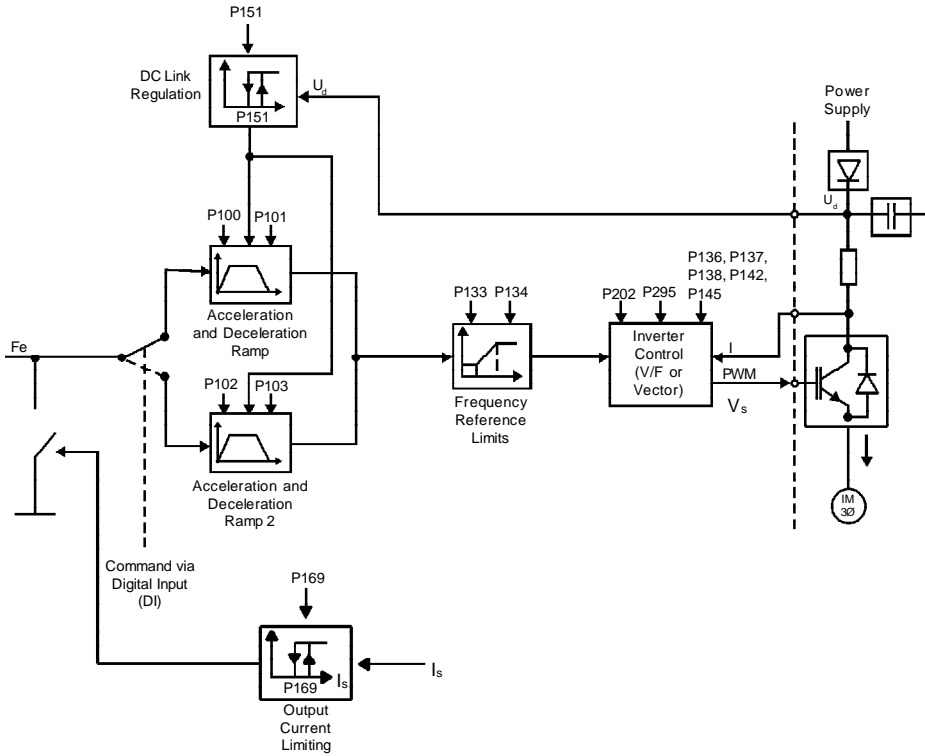

Figure 6.2 - Inverter block diagram



NOTE!

- In V/F control mode ($P202 = 0$ or 1), $F_e = F^*$ (see Fig. 6.1) if $P138 = 0$ (slip compensation disabled). If $P138 \neq 0$, see figure 6.9 for the relation between F_e and F^* .

6.2.3 Commands

The inverter has the following commands: PWM pulse enabling/disabling, definition of the direction of rotation and JOG. As the frequency reference, also the inverter commands can be defined in several ways.

The main command sources are:

- Via keypad key -key  ;
- Via control terminals (XC1) - digital inputs.

The inverter enabling and disabling commands can be defined as follows:

- Via keypad  of the HMI;
- Start/Stop (terminals XC1 - DI(s) - see P263 to P266);
- General enable (terminals XC1 - DI(s) - see P263 to P266);
- Forward and Reverse (terminals XC1 – DI'(s) - see P263 to P266) – also defines the direction of rotation;
- ON/OFF (3-wire controls) (terminals XC1 - DI'(s)- see P263 and P266).

The definition of the direction of rotation can be defined by using:

- Digital input (DI) programmed for FWD/REV (see P263 to P266);
- Digital inputs programmed as FWD / REV, that defines both inverter enabling or disabling and direction of rotation (see P263 to P266);
- Analog input - when the reference is via analog input and a negative offset is programmed (P236 < 0), the reference may assume negative values, thus reversing the direction of the motor rotation.

6.2.4 Local/Remote Operation Modes

User can define two different conditions relating to the frequency reference source and the inverter commands: these are the local and the remote operation modes.

Figure 6.3 shows the local and remote operation modes in a block diagram.

With the factory setting in local mode the inverter can be controlled by using the keypad, (HMI) while in remote mode all controls are via terminals (XC1) - inverter reference and command definition.

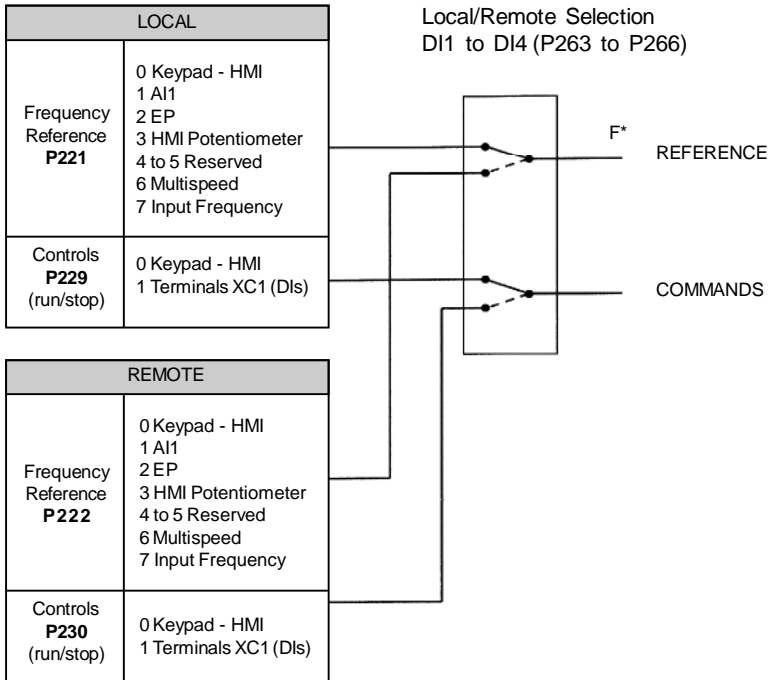

Figure 6.3 - Block diagram of the Local/Remote operation mode

6.3 PARAMETER LISTING

In order to simplify the explanation, the parameters have been grouped by characteristics and functions:

| | |
|-----------------------------|---|
| Read-Only Parameters | Variables that can be viewed on the display, but can not be changed by the user. |
| Regulation Parameters | Programmable values that can be used by the CFW-10 functions. |
| Configuration Parameters | They define the inverter characteristics, the functions to be executed, as well as the input/output functions of the control board. |
| Special Function Parameters | Here are included parameters related to special functions. |

- (1) This parameter can be changed only with the inverter disabled (stopped motor).
- (2) This parameter is not changed when the load factory default routine is executed (P204 = 5).

6.3.1 Access and Read Only Parameters - P000 to P099

| Parameter | Range [Factory Setting] | Description / Notes |
|--|---|--|
| P000 Access Parameter | 0 to 999 [0] 1 | <input checked="" type="checkbox"/> Releases the access to change the parameter values. <input checked="" type="checkbox"/> The password is 5. <input checked="" type="checkbox"/> The use of the password is always active. |
| P002 Frequency Proportional Value | 0 to 999 [-] 0.01 (< 10.0); 0.1 (< 100); 1 (> 99.9) | <input checked="" type="checkbox"/> Indicates the value of P208 x P005. <input checked="" type="checkbox"/> In case of different scales and units, use P208. |
| P003 Motor Current (Output) | 0 to 1.5 x I _{nom} [-] 0.1 A | <input checked="" type="checkbox"/> Indicates the inverter output current in ampères. (A). |
| P004 DC Link Voltage | 0 to 524 [-] 1 V | <input checked="" type="checkbox"/> Indicates the inverter DC Link voltage in volts (V). |
| P005 Motor Frequency (Output) | 0 to 300 [-] 0.1 (< 100); 1 (> 99.9) | <input checked="" type="checkbox"/> Indicates the inverter output frequency in hertz (Hz). |
| P007 Motor Voltage (Output) | 0 to 240 [-] 1 V | <input checked="" type="checkbox"/> Indicates the inverter output voltage in volts (V). |
| P008 Heatsink Temperature | 25 to 110 [-] 1 °C | <input checked="" type="checkbox"/> Indicates the current power at the heatsink in Celsius degrees (°C). <input checked="" type="checkbox"/> The inverter overtemperature protection (E04) acts when heatsink temperature reaches 103 °C. |
| P014 Last Fault | 00 to 41 [-] - | <input checked="" type="checkbox"/> Indicates the code of the last occurred fault. <input checked="" type="checkbox"/> Section 7.1 shows a list of possible faults, their code numbers and possible causes. |
| P015 Second Fault Occurred | 00 to 41 [-] - | <input checked="" type="checkbox"/> Indicates the code of the last occurred fault. <input checked="" type="checkbox"/> Section 7.1 shows a list of possible faults, their code numbers and possible causes. |
| P016 Third Fault Occurred | 00 to 41 [-] - | <input checked="" type="checkbox"/> Indicates the code of the last occurred fault. <input checked="" type="checkbox"/> Section 7.1 shows a list of possible faults, their code numbers and possible causes. |
| P023 Software Version | xyz [-] | <input checked="" type="checkbox"/> Indicates the software version installed in the DSP memory located on the control board. |

CHAPTER 6 - DETAILED PARAMETER DESCRIPTION

6.3.2 Regulation Parameters - P100 to P199

| Parameter | Range [Factory Setting] | Description / Notes |
|---|---|---|
| P040 Variable Process | 0.0 to 999 [-] - | <ul style="list-style-type: none"> <input checked="" type="checkbox"/> Indicates the value of the process variable used as PID regulator feedback, in percent (%). <input checked="" type="checkbox"/> The PID function is only available from V.2.00 software version. <input checked="" type="checkbox"/> The unit scale can be changed through P528. <input checked="" type="checkbox"/> See detailed description of the PID regulator in Special Functions Parameters item. |
| P100 Acceleration Time | 0.1 to 999 s [5.0 s] 0.1 s (< 100); 1 s (> 99.9) | <ul style="list-style-type: none"> <input checked="" type="checkbox"/> This set of parameters defines the times to accelerate linearly from zero up to the rated frequency and to decelerate linearly from the rated frequency down to zero. <input checked="" type="checkbox"/> The rated frequency is defined by parameter P145 . |
| P101 Deceleration Time | 0.1 to 999 s [10.0 s] 0.1 s (< 100); 1 s (> 99.9) | <ul style="list-style-type: none"> <input checked="" type="checkbox"/> When factory setting is used, inverter always follows the time defined in P100 and P101. <input checked="" type="checkbox"/> If Ramp 2 should be used, where the acceleration and deceleration times follow the values programmed at P102 and P103, use a digital input. See parameters P263 to P265. |
| P102 Acceleration Time Ramp 2 | 0.1 to 999 s [5.0 s] 0.1 s (< 100); 1 s (> 99.9) | <ul style="list-style-type: none"> <input checked="" type="checkbox"/> Depending on the load inertia, too short acceleration times can disable the inverter due to overcurrent (E00). <input checked="" type="checkbox"/> Depending on the load inertia, too short deceleration times can disable the inverter due to overvoltage (E01). For more details, refer to P151. |
| P103 Deceleration Time Ramp 2 | 0.1 to 999 s [10.0 s] 0.1 s (< 100); 1 s (> 99.9) | |
| P104 S Ramp | 0 to 2 [0 - Inactive] - | <ul style="list-style-type: none"> <input checked="" type="checkbox"/> The ramp S reduces mechanical stress during the the load acceleration and deceleration. |

| P104 | Ramp S |
|------|----------|
| 0 | Inactive |
| 1 | 50 % |
| 2 | 100 % |



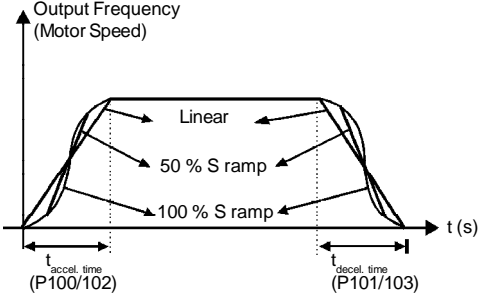



Table 6.1 - Ramp configuration

| Parameter | Range [Factory Setting] | Description / Notes |
|-----------|----------------------------|--|
| | |  <p>Figure 6.4 - S or linear Ramp</p> <p>It is recommended to use the S ramp with digital frequency/speed references.</p> |

| <p>P120 Digital Reference Backup</p> | <p>0 to 3 [1 - active] -</p> | <p>It Defines if the inverter should save or not the last used digital reference. This backup function is only applicable to the keypad reference (P121).</p> <table border="1" data-bbox="584 821 988 965"> <thead> <tr> <th>P120</th> <th>Reference Backup</th> </tr> </thead> <tbody> <tr> <td>0</td> <td>Inactive</td> </tr> <tr> <td>1</td> <td>Active</td> </tr> <tr> <td>2</td> <td>Active, but always given by P121, independently of the source reference</td> </tr> <tr> <td>3</td> <td>Active after ramp</td> </tr> </tbody> </table> | P120 | Reference Backup | 0 | Inactive | 1 | Active | 2 | Active, but always given by P121, independently of the source reference | 3 | Active after ramp |
|---|---|--|------|------------------|---|----------|---|--------|---|---|---|-------------------|
| P120 | Reference Backup | | | | | | | | | | | |
| 0 | Inactive | | | | | | | | | | | |
| 1 | Active | | | | | | | | | | | |
| 2 | Active, but always given by P121, independently of the source reference | | | | | | | | | | | |
| 3 | Active after ramp | | | | | | | | | | | |

Table 6.2 - Backup configuration of digital reference

- It If the digital reference backup is inactive (P120 = 0), the reference will be equal to the minimum frequency every time the inverter is enabled, according to P133.
- It When P120 = 1, inverter saves automatically the digital reference value, (independent of the reference source, keypad, EP). This occurs always when inverter disable is present, independent of the present disable condition (ramp or general), error or undervoltage.
- It When P120 = 2, the initial reference will be given by P121, and saved always the inverter is enabled. Application example: reference via EP when inverter is disabled via digital input and decelerates EP (coming to reference 0). However at a new enable, it is desired that the inverter returns to a frequency different from the minimum frequency, which will be saved at Parameter P121.

| Parameter | Range [Factory Setting] | Description / Notes |
|--|--|--|
| | | <ul style="list-style-type: none"> <input checked="" type="checkbox"/> P120 = 3, works according P120 = 1, however, only update the backup after a start when the output frequency value reaches the previously backup stored value. |
| P121 Frequency Reference by key  and  | P133 to P134 [3.0 Hz] 0.1 Hz (< 100 Hz); 1 Hz (> 99.9 Hz) | <ul style="list-style-type: none"> <input checked="" type="checkbox"/> Defines the keypad reference value that can be set by using the keys  and  when the parameters P002 or P005 are being displayed on the HMI Display. <input checked="" type="checkbox"/> The keys  and  are enabled if P221 = 0 (in local mode) or P222 = 0 (in remote mode). The value of P121 is maintained at the last set value, even when inverter is disabled or turned OFF, provided P120 = 1 or 2 (backup active). |
| P122 JOG Speed Reference | P133 to P134 [5.0 Hz] 0.1 Hz (< 100 Hz); 1 Hz (> 99.9 Hz) | <ul style="list-style-type: none"> <input checked="" type="checkbox"/> Defines the frequency reference (speed) for the JOG function. The JOG function can be activated by using the digital inputs. <input checked="" type="checkbox"/> The inverter must be disabled by ramp (stopped motor) to operate in the JOG function. Thus if the control source is via terminal, there must be at least one digital input programmed as start/stop enabling (otherwise E24 will be displayed), which must be OFF to enable the JOG function via digital input. (See P263 to P266). <input checked="" type="checkbox"/> The rotation direction is defined by P231 parameter. |
| P124 ⁽¹⁾ Multispeed Ref. 1 | P133 to P134 [3.0 Hz] 0.1 Hz (< 100 Hz); 1 Hz (> 99.9 Hz) | <ul style="list-style-type: none"> <input checked="" type="checkbox"/> Multispeed is used when the selection of up to 8 pre-programmed speeds are required. <input checked="" type="checkbox"/> It allows the control of the output speed related to the values programmed by the parameters P124 to P131, according to the logical combination of the digital inputs programmed to multispeed. |
| P125 ⁽¹⁾ Multispeed Ref. 2 | P133 to P134 [10.0 Hz] 0.1 Hz (< 100 Hz); 1 Hz (> 99.9 Hz) | <ul style="list-style-type: none"> <input checked="" type="checkbox"/> Activation of the multispeed function: To ensure that the reference source is given by the multispeed function, i.e., setting P221 = 6 for local mode or P222 = 6 for remote mode; To program one or more digital inputs to multispeed, according to table below: |
| P126 ⁽¹⁾ Multispeed Ref. 3 | P133 to P134 [20.0 Hz] 0.1 Hz (< 100 Hz); 1 Hz (> 99.9 Hz) | |
| P127 ⁽¹⁾ Multispeed Ref. 4 | P133 to P134 [30.0 Hz] 0.1 Hz (< 100 Hz); 1 Hz (> 99.9 Hz) | |

| DIenable | Programming |
|------------|--------------------------|
| DI1 or DI2 | P263 = 7/8 or P264 = 7/8 |
| DI3 | P265 = 7/8 |
| DI4 | P266 = 7/8 |

Table 6.3 - Parameters setting to define multispeed function on DI's

| Parameter | Range [Factory Setting] | Description/Notes | | | | | | | | | | | | | | | | | | | | | | | | | | | | | | | | | | | | | | | | | | | | |
|---|--|---|----------|------|-----------------|--|----------|--|--|----------|------------|-----|-----|-----------------|------|------|------|------|------|------|-----|------|------|-----|------|------|------|-----|-----|------|-----|------|------|------|-----|------|-----|------|-----|-----|------|------|-----|-----|-----|------|
| P128 ⁽¹⁾ Multispeed Ref. 5 | P133 to P134 [40.0 Hz] 0.1 Hz (< 100 Hz); 1 Hz (> 99.9 Hz) | ☑ The frequency reference is defined by the status of the digital inputs programmed to multispeed as shown in table below: | | | | | | | | | | | | | | | | | | | | | | | | | | | | | | | | | | | | | | | | | | | | |
| P129 ⁽¹⁾ Multispeed Ref. 6 | P133 to P134 [50.0 Hz] 0.1 Hz (< 100 Hz); 1 Hz (> 99.9 Hz) | <table border="1"> <thead> <tr> <th colspan="4">8 speeds</th> </tr> <tr> <th colspan="3">4 speeds</th> <th rowspan="2">2 speeds</th> </tr> <tr> <th>DI1 or DI2</th> <th>DI3</th> <th>DI4</th> <th>Freq. Reference</th> </tr> </thead> <tbody> <tr> <td>Open</td> <td>Open</td> <td>Open</td> <td>P124</td> </tr> <tr> <td>Open</td> <td>Open</td> <td>0 V</td> <td>P125</td> </tr> <tr> <td>Open</td> <td>0 V</td> <td>Open</td> <td>P126</td> </tr> <tr> <td>Open</td> <td>0 V</td> <td>0 V</td> <td>P127</td> </tr> <tr> <td>0 V</td> <td>Open</td> <td>Open</td> <td>P128</td> </tr> <tr> <td>0 V</td> <td>Open</td> <td>0 V</td> <td>P129</td> </tr> <tr> <td>0 V</td> <td>0 V</td> <td>Open</td> <td>P130</td> </tr> <tr> <td>0 V</td> <td>0 V</td> <td>0 V</td> <td>P131</td> </tr> </tbody> </table> | 8 speeds | | | | 4 speeds | | | 2 speeds | DI1 or DI2 | DI3 | DI4 | Freq. Reference | Open | Open | Open | P124 | Open | Open | 0 V | P125 | Open | 0 V | Open | P126 | Open | 0 V | 0 V | P127 | 0 V | Open | Open | P128 | 0 V | Open | 0 V | P129 | 0 V | 0 V | Open | P130 | 0 V | 0 V | 0 V | P131 |
| 8 speeds | | | | | | | | | | | | | | | | | | | | | | | | | | | | | | | | | | | | | | | | | | | | | | |
| 4 speeds | | | 2 speeds | | | | | | | | | | | | | | | | | | | | | | | | | | | | | | | | | | | | | | | | | | | |
| DI1 or DI2 | DI3 | | | DI4 | Freq. Reference | | | | | | | | | | | | | | | | | | | | | | | | | | | | | | | | | | | | | | | | | |
| Open | Open | | Open | P124 | | | | | | | | | | | | | | | | | | | | | | | | | | | | | | | | | | | | | | | | | | |
| Open | Open | | 0 V | P125 | | | | | | | | | | | | | | | | | | | | | | | | | | | | | | | | | | | | | | | | | | |
| Open | 0 V | | Open | P126 | | | | | | | | | | | | | | | | | | | | | | | | | | | | | | | | | | | | | | | | | | |
| Open | 0 V | | 0 V | P127 | | | | | | | | | | | | | | | | | | | | | | | | | | | | | | | | | | | | | | | | | | |
| 0 V | Open | Open | P128 | | | | | | | | | | | | | | | | | | | | | | | | | | | | | | | | | | | | | | | | | | | |
| 0 V | Open | 0 V | P129 | | | | | | | | | | | | | | | | | | | | | | | | | | | | | | | | | | | | | | | | | | | |
| 0 V | 0 V | Open | P130 | | | | | | | | | | | | | | | | | | | | | | | | | | | | | | | | | | | | | | | | | | | |
| 0 V | 0 V | 0 V | P131 | | | | | | | | | | | | | | | | | | | | | | | | | | | | | | | | | | | | | | | | | | | |
| P130 ⁽¹⁾ Multispeed Ref. 7 | P133 to P134 [60.0 Hz] 0.1 Hz (< 100 Hz); 1 Hz (> 99.9 Hz) | | | | | | | | | | | | | | | | | | | | | | | | | | | | | | | | | | | | | | | | | | | | | |
| P131 ⁽¹⁾ Multispeed Ref. 8 | P133 to P134 [66.0 Hz] 0.1 Hz (< 100 Hz); 1 Hz (> 99.9 Hz) | | | | | | | | | | | | | | | | | | | | | | | | | | | | | | | | | | | | | | | | | | | | | |

Table 6.4 - Frequency reference

- ☑ If a multi-speed reference (P124 to P131) is set to 0.0 Hz and this same reference is selected, the drive will decelerate to 0.0 Hz and will remain ready (RDY) while the selection is kept.
- ☑ The multispeed function has some advantages for the stability of the fixed preprogrammed references and the immunity against electrical noises (digital references and insulated digital inputs).

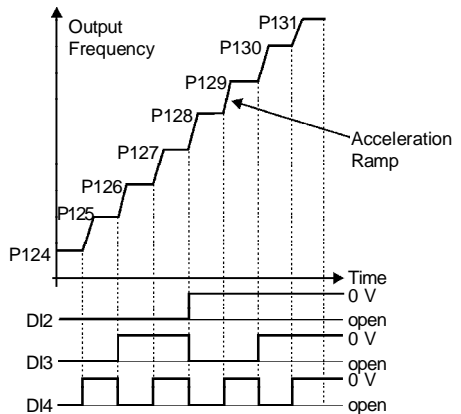

Figure 6.5 - Time Diagram of the multispeed function

| Parameter | Range [Factory Setting] | Description / Notes |
|--|---|---|
| P133 ⁽¹⁾ Minimum Frequency (F_{min}) | 0.0 to P134 [3.0 Hz] 0.1 Hz (< 100 Hz); 1 Hz (> 99.9 Hz) | <ul style="list-style-type: none"> <input checked="" type="checkbox"/> Defines the maximum and minimum output frequency (motor) when inverter is enabled. <input checked="" type="checkbox"/> It is valid for any type of speed reference. <input checked="" type="checkbox"/> The parameter P133 defines a dead zone when analog inputs are used - see parameters P234 to P236. |
| P134 ⁽¹⁾ Maximum Frequency (F_{max}) | P133 to 300 [66.0 Hz] 0.1 Hz (< 100 Hz); 1 Hz (> 99.9 Hz) | <ul style="list-style-type: none"> <input checked="" type="checkbox"/> P134 and the gain and offset of the analog input(s) (P234, P236) define the scale and the range of the speed variation via analog input. For more details see parameters P234 to P236. |
| P136 Manual Torque Boost (I x R Compensation) | 0.0 to 100 [20.0] 0.1 % For the 15.2 A model the factory adjustment is [6.0] | <ul style="list-style-type: none"> <input checked="" type="checkbox"/> Compensates the voltage drop due to the motor stator resistance. It acts at low speeds by increasing the inverter output voltage, in order to maintain a constant torque during the V/F operation. <input checked="" type="checkbox"/> The best setting is to program the lowest value for P136 that still permits the motor start satisfactorily. If the value is higher than required, an inverter overcurrent (E00 or E05) may occur due to high motor currents at low speeds. <input checked="" type="checkbox"/> The setting P136 = 100 % corresponds to the maximum increment of the output voltage (30 % of P142). <p>a) P202 = 0</p>  |

Figure 6.6 a) - V/F curve and details of the manual torque boost (I x R compensation)

| Parameter | Range [Factory Setting] | Description / Notes |
|-----------|----------------------------|--|
| | | <p>b) P202 = 1</p>  <p>Figure 6.6 b) cont. - V/F curve and details of the manual torque boost (I x R compensation)</p> |

| | | |
|--|-------------------------------------|---|
| <p>P137 Automatic Torque Boost (Automatic I x R Compensation)</p> | <p>0.0 to 100 % [0.0] -</p> | <ul style="list-style-type: none"> ☑ The automatic torque boost compensates for the voltage drop in the stator resistance as a function of the active motor current. ☑ The criteria for setting P137 are the same as for the parameter P136. ☑ Setting P137 = 100 % corresponds to the maximum increment of the output voltage (30 % of P142). |
|--|-------------------------------------|---|

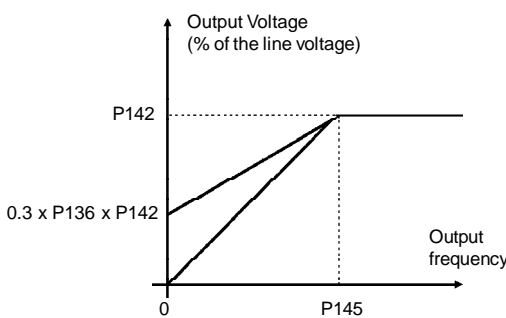
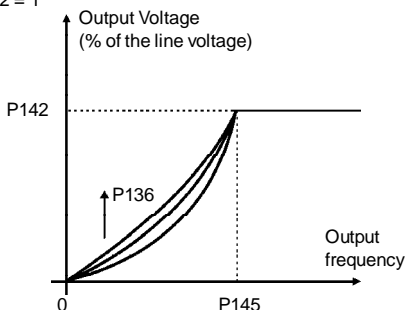
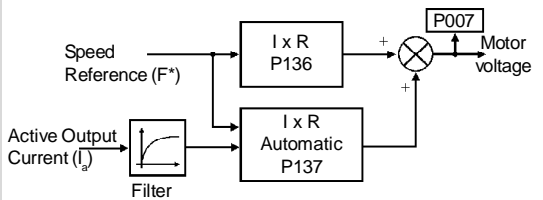

Figure 6.7 - Block diagram of the automatic torque boost function

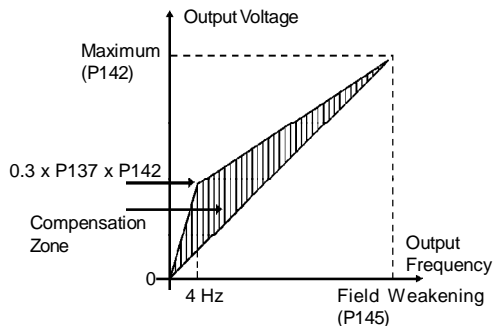

Figure 6.8 - V/F curve with automatic torque boost (automatic I x R compensation)

| Parameter | Range [Factory Setting] | Description / Notes |
|-------------------------------------|---------------------------------|--|
| P138 Slip Compensation | 0.0 to 10.0 [0.0] 0.1 % | <ul style="list-style-type: none"> ☑ The parameter P138 is used in the motor slip compensation function. ☑ This function compensates the drop of the motor speed due to load, which is an inherent characteristic relating to the operation principle of the induction motor. ☑ This speed drop is compensated by increasing the output frequency (applied to the motor) as a function of the increase of the active motor current, as shown in the block diagram and in the V/F curve below. |

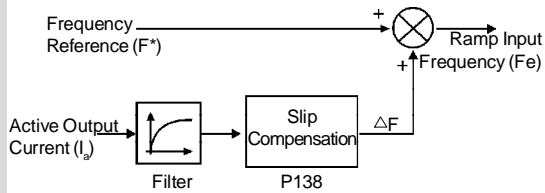

Figure 6.9 - Block diagram of the slip compensation function

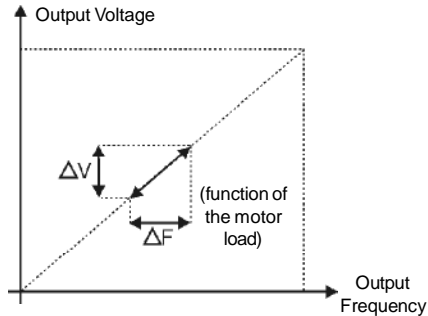
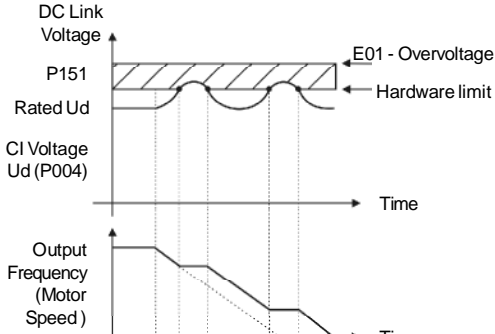

Figure 6.10 - V/F curve with slip compensation

- ☑ To set the parameter P138 adopt the following procedure:
 - run the motor without load up to approximately half of the application top speed;
 - measure the actual motor or equipment speed;
 - apply rated load to equipment;
 - increase parameter P138 until the speed reaches its no-load speed.

| Parameter | Range [Factory Setting] | Description / Notes |
|--|--|---|
| P142 ⁽¹⁾⁽²⁾ Maximum Output Voltage | 0 to 100 [100] 0.1 % | <ul style="list-style-type: none"> ☑ Define the V/F curve used in V/Fcontrol (P202 = 0 or 1). ☑ These parameters allow changing the standard V/F curve defined at P202 - programmable V/F curve. ☑ P142 sets the maximum output voltage. This value is set as a percent of the inverter supply voltage. |
| P145 ⁽¹⁾⁽²⁾ Field Weakening Frequency (Rated Frequency) | P133 to P134 [60.0 Hz] 0.01 Hz (< 100 Hz) 1 Hz (> 99.9 Hz) | <p>NOTE! For inverter models 110-127 V; the output voltage applied to the motor is doubled the power supply voltage on the inverter input.</p> <ul style="list-style-type: none"> ☑ Parameter P145 defines the rated frequency of the motor used. ☑ The V/F curve relates the inverter output voltage and frequency (applied to the motor) and consequently the magnetizing flux of the motor. ☑ The programmable V/F curve can be used in special applications where the motors used require a rated voltage and/or frequency different than the standard ones. Examples: motor for 220 V/300 Hz and a motor for 200 V/60 Hz. ☑ Parameter P142 is also useful in applications that require rated voltage different from the inverter supply voltage. Example: 220 V line and 200 V motor. |
| | | |
| P151 DC Link Voltage Regulation Level | 360 to 460 (line 110-127 V) [430] 1 V 325 to 410 (line 200-240 V) [380] 1 V | <ul style="list-style-type: none"> ☑ The DC link voltage regulation (ramp holding) avoids inverter disable due to overvoltage trips (E01) during deceleration of loads with high inertia or short deceleration times. ☑ It acts in order to increase the deceleration time (according to load - inertia), thus avoiding the E01 activation. |

Figure 6.11 - Adjustable V/F curve

| Parameter | Range [Factory Setting] | Description / Notes |
|-----------|----------------------------|--|
| | |  <p>Figure 6.12 - Deceleration curve with DC Link voltage regulation</p> <ul style="list-style-type: none"> <input checked="" type="checkbox"/> By this function an optimized deceleration time (minimum) is achieved for the driven load. <input checked="" type="checkbox"/> This function is useful in applications with medium inertia that require short deceleration times. <input checked="" type="checkbox"/> In case of overvoltage trip during the deceleration, you must reduce gradually the value of P151 or increase the time of the deceleration ramp (P101 and/ or P103). <input checked="" type="checkbox"/> The motor will not stop if the line is permanently with overvoltage ($U_d > P151$). In this case, reduce the line voltage, or increase the value of P151. <input checked="" type="checkbox"/> If even with these settings the motor does not decelerate within the required time, you will have the alternative to increase P136; |

P156
Motor Overload
Current

$0.3 \times I_{nom}$ to $1.3 \times I_{nom}$
[**1.2 x P295**]
0.1 A

- This function is used to protect the motor against overload ($I \times t$ function - E05).
- The motor overload current is the current level above which the inverter will consider the motor operating under overload. The higher the difference between the motor current and the overload current, the sooner the $I \times t$ function - E05 - will act.

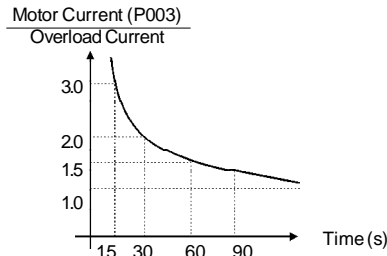

Figure 6.13 - $I \times t$ function – Overload detection

- Parameter P156 shall be set to a value 10 % to 20 % higher than the motor rated current.

| Parameter | Range [Factory Setting] | Description / Notes |
|---|--|--|
| P169⁽²⁾ Maximum Output Current | $0.2 \times I_{nom}$ to $2.0 \times I_{nom}$ [1.5 x P295] 0.1 A | <p><input checked="" type="checkbox"/> Prevents motor stalling during an overload. If motor load increases its current will increase too. If the motor current attempts to exceed the value set at P169, the motor speed will be decreased by following the deceleration ramp until the current becomes lower than P169. As soon as the overload condition disappears, the motor speed is resumed.</p> <p>Figure 6.14 - Curves showing the operation of the current limitation</p> <p><input checked="" type="checkbox"/> The "current limiting" function disabled when setting P169 > 1.5 x P295.</p> |

6.3.3 Configuration Parameters - P200 to P398

| P202⁽¹⁾ Type of Control | 0 to 1 [0 - V/F linear] - | <p><input checked="" type="checkbox"/> Defines the inverter control mode.</p> <table border="1" data-bbox="590 1098 994 1173"> <thead> <tr> <th>P202</th> <th>Type of Control</th> </tr> </thead> <tbody> <tr> <td>0</td> <td>Linear V/F Control (scalar)</td> </tr> <tr> <td>1</td> <td>Quadratic V/F Control (scalar)</td> </tr> </tbody> </table> <p>Table 6.5 - P202 setting for each control type</p> <p><input checked="" type="checkbox"/> As shown in table above, there are 2 V/F control modes:</p> <ul style="list-style-type: none"> - Linear V/F control: this control mode ensures a flux in the motor air gap approximately constant from around 3 Hz up to the field weakening (defined by the parameters P142 and P145). Thus in this speed range, an approximately constant torque capacity is obtained. This control mode is | P202 | Type of Control | 0 | Linear V/F Control (scalar) | 1 | Quadratic V/F Control (scalar) |
|--|--|---|------|-----------------|---|-----------------------------|---|--------------------------------|
| P202 | Type of Control | | | | | | | |
| 0 | Linear V/F Control (scalar) | | | | | | | |
| 1 | Quadratic V/F Control (scalar) | | | | | | | |











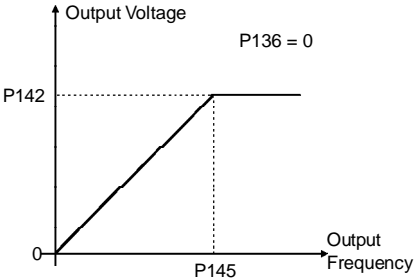
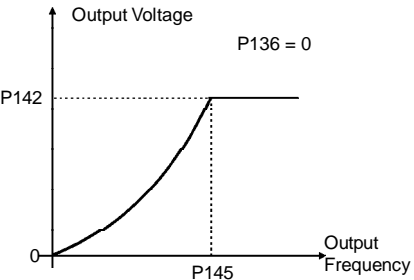

| Parameter | Range [Factory Setting] | Description / Notes |
|-----------|----------------------------|--|
| | | <p>recommended for belt conveyors, extruding machines, etc.</p> <p>- Quadratic V/F control: in this control mode the flux in the motor air gap is proportional to the output frequency up to the field weakening point (defined at P142 and P145). Thus the torque capacity is a function of the quadratic speed. The main advantage of this type of control is the energy saving capability with variable torque loads, due to the reduction of the motor losses (mainly due to motor iron losses and magnetic losses).</p> <p>Example of a application: centrifugal pumps, fans, multimotor drivings.</p> <p>a) linear V/F</p>  <p>b) Quadratic V/F</p>  |

Figure 6.15 a) b) - V/F Control modes (scalar)

| Parameter | Range [Factory Setting] | Description / Notes | | | | | | |
|---|---|---|------|------------------|---|------|---|---------------|
| P203⁽¹⁾ Special Functions Selection | 0 to 1 [0 - None] - | <p><input checked="" type="checkbox"/> Selects or not the PID Regulator special function.</p> <table border="1" data-bbox="645 252 901 328"> <thead> <tr> <th>P203</th> <th>Special Function</th> </tr> </thead> <tbody> <tr> <td>0</td> <td>None</td> </tr> <tr> <td>1</td> <td>PID Regulator</td> </tr> </tbody> </table> <p><i>Table 6.6 - P203 configuration to use or not the PID regulator special function</i></p> <p><input checked="" type="checkbox"/> For PID Regulator special function see detailed description of the related parameters (P520 to P528).</p> <p><input checked="" type="checkbox"/> When P203 is changed to 1, it is necessary to program one of the digital inputs P263 to P266 for 27 (DIX = manual/automatic).</p> | P203 | Special Function | 0 | None | 1 | PID Regulator |
| P203 | Special Function | | | | | | | |
| 0 | None | | | | | | | |
| 1 | PID Regulator | | | | | | | |
| P204⁽¹⁾ Loads Factory Setting | 0 to 999 [0] - | <p><input checked="" type="checkbox"/> Programs all parameters to the standard factory default, when P204 = 5.</p> <p> NOTE! The parameters P142 (max. output voltage), P145 (field weakening frequency), P156 (motor overload current), P169 (maximum output current) are not changed.</p> | | | | | | |
| P206 Auto-Reset Time | 0 to 255 [0] 1 s | <p><input checked="" type="checkbox"/> In the event of a fault trip, except for E09, E24, E31 and E41, the inverter can start an automatic reset after the time given by P206 is elapsed.</p> <p><input checked="" type="checkbox"/> If P206 ≤ 2 Auto-Reset does not occur.</p> <p><input checked="" type="checkbox"/> If after Auto-Reset the same fault is repeated three times consecutively, the Auto-Reset function will be disabled. A fault is considered consecutive if it happens again within 60 seconds after the Auto-Reset. Thus if a fault occurs four times consecutively, this fault remains indicated permanently (and inverter disabled).</p> | | | | | | |
| P208 Reference Scale Factor | 0.0 to 100 [1.0] 0.01 (< 10.0) 0.1 (> 9.99) | <p><input checked="" type="checkbox"/> It allows that the read-only parameter P002 indicates the motor speed in any value, for instance, rpm.</p> <p><input checked="" type="checkbox"/> The indication of P002 is equal to the output frequency value (P005) multiplied by the value of P208, i.e., P002 = P208 x P005.</p> <p><input checked="" type="checkbox"/> Always when the value of the multiplication of P208 x P005 is higher than 999, the displayed value remains at 999.</p> | | | | | | |
| P219⁽¹⁾ Switching Frequency Reduction Point | 0.0 to 15.0 [15.0] 0.1 Hz | <p><input checked="" type="checkbox"/> Defines the point where there is automatic gradual reduction of the switching frequency.</p> <p><input checked="" type="checkbox"/> This improves considerably the measurement of the output current at low frequencies, and consequently improves the inverter performance.</p> <p><input checked="" type="checkbox"/> In application where it is not possible to operate the inverter at low frequencies, ex. 2.5 kHz (for instance, due to acoustic noise), set P219 = 0.0.</p> | | | | | | |

| Parameter | Range [Factory Setting] | Description / Notes | | | | | | | | | | | | | | | | |
|---|---|---|-----------|------------------|---|---|---|---|---|-------------------------------|---|--|--------|----------|---|---------------------------|---|-----------------|
| P221⁽¹⁾ Local Reference Selection | 0 to 7 [0 - keys] - | <p><input checked="" type="checkbox"/> Defines the frequency reference selection in the Local and Remote mode.</p> <table border="1"> <thead> <tr> <th>P221/P222</th> <th>Reference Source</th> </tr> </thead> <tbody> <tr> <td>0</td> <td>Keys  and  of the HMIs (P121)</td> </tr> <tr> <td>1</td> <td>Analog input AI1' (P234, P235 and P236)</td> </tr> <tr> <td>2</td> <td>Electronic potentiometer (EP)</td> </tr> <tr> <td>3</td> <td>HMI potentiometer (Only on Plus version)</td> </tr> <tr> <td>4 to 5</td> <td>Reserved</td> </tr> <tr> <td>6</td> <td>Multispeed (P124 to P131)</td> </tr> <tr> <td>7</td> <td>Input Frequency</td> </tr> </tbody> </table> | P221/P222 | Reference Source | 0 | Keys  and  of the HMIs (P121) | 1 | Analog input AI1' (P234, P235 and P236) | 2 | Electronic potentiometer (EP) | 3 | HMI potentiometer (Only on Plus version) | 4 to 5 | Reserved | 6 | Multispeed (P124 to P131) | 7 | Input Frequency |
| P221/P222 | Reference Source | | | | | | | | | | | | | | | | | |
| 0 | Keys  and  of the HMIs (P121) | | | | | | | | | | | | | | | | | |
| 1 | Analog input AI1' (P234, P235 and P236) | | | | | | | | | | | | | | | | | |
| 2 | Electronic potentiometer (EP) | | | | | | | | | | | | | | | | | |
| 3 | HMI potentiometer (Only on Plus version) | | | | | | | | | | | | | | | | | |
| 4 to 5 | Reserved | | | | | | | | | | | | | | | | | |
| 6 | Multispeed (P124 to P131) | | | | | | | | | | | | | | | | | |
| 7 | Input Frequency | | | | | | | | | | | | | | | | | |
| P222⁽¹⁾ Remote Reference Selection | 0 to 7 [1 - AI1] - | <p>Table 6.7 - P221 programming (local mode) or P222 (remote mode) for speed reference selection</p> <p><input checked="" type="checkbox"/> AI1' is the value of the analog input AI1 when gain and offset have been applied.</p> <p><input checked="" type="checkbox"/> For factory default setting, the local reference is via  and  keys of the keypad and the remote reference is via analog input AI1. On CFW-10 Plus version, local reference via HMI potentiometer is the factory default setting.</p> <p><input checked="" type="checkbox"/> The reference value set by the  and  keys is contained in parameter P121.</p> <p><input checked="" type="checkbox"/> For more details about the Electronic Potentiometer (EP) operation, refer to figure 6.19.</p> <p><input checked="" type="checkbox"/> When option 6 (multispeed) is selected, set P263-P264 and/or P265 and/or P266 to 7/8.</p> <p><input checked="" type="checkbox"/> For more details, refer to items 6.2.2 and 6.2.4.</p> <p><input checked="" type="checkbox"/> Program P263 or P264 or P265 or P266 in 26 when option 7 (frequency input) is selected.</p> | | | | | | | | | | | | | | | | |
| P229⁽¹⁾ Local Command Selection | 0 to 1 [0 - Keys] - | <p><input checked="" type="checkbox"/> Define the control sources for the inverter enabling / disabling.</p> <table border="1"> <thead> <tr> <th>P229/P230</th> <th>Control Source</th> </tr> </thead> <tbody> <tr> <td>0</td> <td>HMI Keypad</td> </tr> <tr> <td>1</td> <td>Terminals (XC1)</td> </tr> </tbody> </table> | P229/P230 | Control Source | 0 | HMI Keypad | 1 | Terminals (XC1) | | | | | | | | | | |
| P229/P230 | Control Source | | | | | | | | | | | | | | | | | |
| 0 | HMI Keypad | | | | | | | | | | | | | | | | | |
| 1 | Terminals (XC1) | | | | | | | | | | | | | | | | | |
| P230⁽¹⁾ Remote Command Selection | 0 to 1 [1 - Terminals] - | <p>Table 6.8 - P229 and P230 programming to origin selection of inverter commands</p> <p><input checked="" type="checkbox"/> The direction of rotation is the only operation control that depends on other parameter for operation - P231.</p> <p><input checked="" type="checkbox"/> For more details, refer to Items 6.2.2, 6.2.3 and 6.2.4.</p> | | | | | | | | | | | | | | | | |

| Parameter | Range [Factory Setting] | Description / Notes | | | | | | | | |
|---|--------------------------------------|--|------|-----------------------|---|----------------|---|----------------|---|--------------------------------------|
| P231⁽¹⁾ Forward/Reverse - Local/Remote Modes | 0 to 2 [2 - Commands] | <input checked="" type="checkbox"/> Defines the direction of rotation. <table border="1" data-bbox="631 252 941 373"> <thead> <tr> <th>P231</th> <th>Direction of rotation</th> </tr> </thead> <tbody> <tr> <td>0</td> <td>Always forward</td> </tr> <tr> <td>1</td> <td>Always reverse</td> </tr> <tr> <td>2</td> <td>Commands as defined in P229 and P230</td> </tr> </tbody> </table> | P231 | Direction of rotation | 0 | Always forward | 1 | Always reverse | 2 | Commands as defined in P229 and P230 |
| P231 | Direction of rotation | | | | | | | | | |
| 0 | Always forward | | | | | | | | | |
| 1 | Always reverse | | | | | | | | | |
| 2 | Commands as defined in P229 and P230 | | | | | | | | | |

Table 6.9 - P231 programming to select rotation direction

| | |
|---|--|
| P234 Analog Input AI1 Gain (Software Version 2.0X) | 0.0 to 999 [100] 0.1 (< 100) 1 (> 99.9) |
|---|--|

The analog input AI1 defines the inverter frequency reference as shown in the curve below.

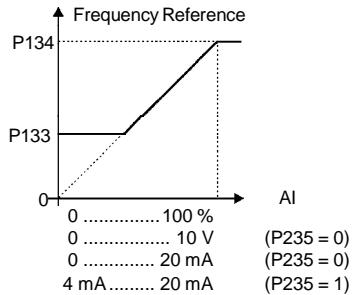

Figure 6.17 a) - Analog Input AI1 Signal x Frequency reference

Note that there is always a dead zone at the starting of the curve where the frequency reference remains at the value of the minimum frequency (P133), even when the input signal is changed. This dead zone is only suppressed when P133 = 0.0.

The internal value AI1' that defines the frequency reference to be used by the inverter, is given as percent of the full scale reading and is obtained by using one of the following equations (see P235):

| P235 | Signal | Equation |
|------|--------------|--|
| 0 | (0 to 10) V | $AI1' = \left(\frac{AI1}{10} + \frac{OFFSET}{100} \right) \cdot GAIN$ |
| 0 | (0 to 20) mA | $AI1' = \left(\frac{AI1}{20} + \frac{OFFSET}{100} \right) \cdot GAIN$ |
| 1 | (4 to 20) mA | $AI1' = \left(\frac{AI1-4}{16} + \frac{OFFSET}{100} \right) \cdot GAIN$ |

Table 6.10 a) - Analog input signal AI1 (P235) definition

Where:

- AI1 is given in V or mA, according to the used signal (see parameter P235);
- GAIN is defined by the parameter P234;
- OFFSET is defined by the parameter P236.

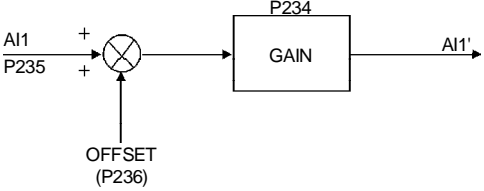
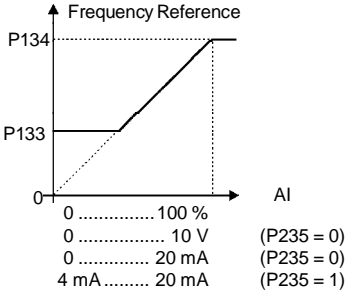
| Parameter | Range [Factory Setting] | Description / Notes |
|---|---|---|
| | | <p>☑ This is shown in the block diagram below:</p>  <p><i>Figure 6.18 a) - Block diagram of the analog input AI1</i></p> <p>☑ Following situation as example: AI1 is the voltage input (0-10 V - P235 = 0), AI1 = 5 V, P234 = 1.00 and P236 = -70 %. Thus:</p> $AI1' = \left[\frac{5}{10} + \frac{(-70)}{100} \right] \cdot 1 = -0.2 = -20 \%$ <p>The motor will run in reverse direction of rotation as defined by the commands (negative value) - if this is possible (P231 = 2), with a module reference equal to 0.2 or 20 % of the maximum output frequency (P134). I.e., if P134 = 66.0 Hz, then the frequency reference is equal to 13.2 Hz.</p> |
| <p>P234 Analog Input AI1 Gain (Software Version 2.2X)</p> | <p>0.0 to 999 [100] 0.1 (< 100) 1 (> 99.9)</p> | <p>☑ The analog input AI1 defines the inverter frequency reference as shown in the curve below.</p>  <p><i>Figure 6.17 b) - Analog Input AI1 Signal x Frequency reference</i></p> |

| Parameter | Range [Factory Setting] | Description / Notes | | | | | | | | | | | | |
|-----------|----------------------------|--|------|--------|----------|---|-----------|--|---|------------|--|---|------------|--|
| | | <p>☑ Note that there is always a dead zone at the starting of the curve where the frequency reference remains at the value of the minimum frequency (P133), even when the input signal is changed. This dead zone is only suppressed when P133 = 0.0.</p> <p>☑ The internal value AI1' that defines the frequency reference to be used by the inverter, is given as percent of the full scale reading and is obtained by using one of the following equations (see P235):</p> <table border="1"> <thead> <tr> <th>P235</th> <th>Signal</th> <th>Equation</th> </tr> </thead> <tbody> <tr> <td>0</td> <td>0 to 10 V</td> <td>$AI1' = \left(\frac{Alx \cdot GAIN}{10} + \frac{OFFSET}{100} \right)$</td> </tr> <tr> <td>0</td> <td>0 to 20 mA</td> <td>$AI1' = \left(\frac{Alx \cdot GAIN}{20} + \frac{OFFSET}{100} \right)$</td> </tr> <tr> <td>1</td> <td>4 to 20 mA</td> <td>$AI1' = \left(\frac{(Alx - 4)}{16} \cdot GAIN + \frac{OFFSET}{100} \right)$</td> </tr> </tbody> </table> | P235 | Signal | Equation | 0 | 0 to 10 V | $AI1' = \left(\frac{Alx \cdot GAIN}{10} + \frac{OFFSET}{100} \right)$ | 0 | 0 to 20 mA | $AI1' = \left(\frac{Alx \cdot GAIN}{20} + \frac{OFFSET}{100} \right)$ | 1 | 4 to 20 mA | $AI1' = \left(\frac{(Alx - 4)}{16} \cdot GAIN + \frac{OFFSET}{100} \right)$ |
| P235 | Signal | Equation | | | | | | | | | | | | |
| 0 | 0 to 10 V | $AI1' = \left(\frac{Alx \cdot GAIN}{10} + \frac{OFFSET}{100} \right)$ | | | | | | | | | | | | |
| 0 | 0 to 20 mA | $AI1' = \left(\frac{Alx \cdot GAIN}{20} + \frac{OFFSET}{100} \right)$ | | | | | | | | | | | | |
| 1 | 4 to 20 mA | $AI1' = \left(\frac{(Alx - 4)}{16} \cdot GAIN + \frac{OFFSET}{100} \right)$ | | | | | | | | | | | | |

Table 6.10 b) - Analog input signal AI1 (P235) definition

Where:

- AI1 is given in V or mA, according to the used signal (see parameter P235);
- GAIN is defined by the parameter P234;
- OFFSET is defined by the parameter P236.

☑ This is shown in the block diagram below:

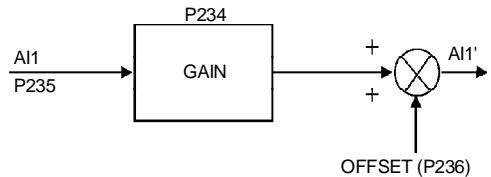

Figure 6.18 b) - Block diagram of the analog input AI1

☑ Following situation as example: AI1 is the voltage input (0-10 V - P235 = 0), AI1 = 5 V, P234 = 1.00 and P236 = -70 %.

Thus:

$$AI1' = \left[\frac{5}{10} \cdot 1.00 + \frac{(-70)}{100} \right] = -20 \%$$

The motor will run in reverse direction of rotation as defined by the commands (negative value) - if this is possible (P231 = 2), with a module reference equal to 0.2 or 20 % of the maximum output frequency (P134). I.e., if P134 = 66.0 Hz, then the frequency reference is equal to 13.2 Hz.

CHAPTER 6 - DETAILED PARAMETER DESCRIPTION

| Parameter | Range [Factory Setting] | Description / Notes | | | | | | | | | | | | | | | | | | | | |
|---|--|--|--------------------------|---|----------|----------------------------|---|--------------|----------------|---|-----|---|------------|---|---------|---|--------------|---|------------|---|------------------------|---|
| P235⁽¹⁾ Analog Input AI1 Signal | 0 to 1 [0] | <input checked="" type="checkbox"/> Defines the signal type of the analog input, as shown in table below: <table border="1" data-bbox="514 284 820 357" style="margin-left: auto; margin-right: auto;"> <thead> <tr> <th>P235</th> <th>Signal Type</th> </tr> </thead> <tbody> <tr> <td>0</td> <td>(0 to10) V or (0 to 20) mA</td> </tr> <tr> <td>1</td> <td>(4 to 20) mA</td> </tr> </tbody> </table> | P235 | Signal Type | 0 | (0 to10) V or (0 to 20) mA | 1 | (4 to 20) mA | | | | | | | | | | | | | | |
| P235 | Signal Type | | | | | | | | | | | | | | | | | | | | | |
| 0 | (0 to10) V or (0 to 20) mA | | | | | | | | | | | | | | | | | | | | | |
| 1 | (4 to 20) mA | | | | | | | | | | | | | | | | | | | | | |
| <i>Table 6.11 - P235 setting according to signal type/excursion</i> | | | | | | | | | | | | | | | | | | | | | | |
| P236 Analog Input AI1 Offset | -120 to +120 [0] 1 % | <input checked="" type="checkbox"/> See P234. | | | | | | | | | | | | | | | | | | | | |
| P238 Input Gain (HMI Potentiometer) | 0.0 to 999 [100] 0.1(< 100) 1(> 99.9) | <input checked="" type="checkbox"/> See P234. | | | | | | | | | | | | | | | | | | | | |
| P240 Input Offset (HMI Potentiometer) | -120 to +120 [0] 1 % | <input checked="" type="checkbox"/> See P234. | | | | | | | | | | | | | | | | | | | | |
| P248 Analog Inputs Filter Time Constant | 0 to 200 [200] 1 ms | <input checked="" type="checkbox"/> It configures the time constant of the analog inputs filter between 0 (without filtering) and 200 ms. <input checked="" type="checkbox"/> Thus the analog input will have a response time equal to three time constants. For instance, if the time constant is 200 ms, and a step is applied to the analog input, the response will be stabilized after 600 ms. | | | | | | | | | | | | | | | | | | | | |
| P263⁽¹⁾ Digital Input DI1 Function | 0 to 27 [1 - Not used (HMI) or General Enable (Terminals)] - | <input checked="" type="checkbox"/> Check possible options on table below and details about each function operation in Figure 6.19. <table border="1" data-bbox="434 1187 940 1477" style="margin-left: auto; margin-right: auto;"> <thead> <tr> <th>DI Parameter Function</th> <th>DI1 (P263), DI2 (P264), DI3 (P265), DI4 (P266)</th> </tr> </thead> <tbody> <tr> <td>Not used</td> <td>0</td> </tr> <tr> <td>Not used (HMI) or General Enable (Terminals)</td> <td>1</td> </tr> <tr> <td>General Enable</td> <td>2</td> </tr> <tr> <td>JOG</td> <td>3</td> </tr> <tr> <td>Start/Stop</td> <td>4</td> </tr> <tr> <td>FWD/REV</td> <td>5</td> </tr> <tr> <td>Local/Remote</td> <td>6</td> </tr> <tr> <td>Multispeed</td> <td>7</td> </tr> <tr> <td>Multispeed with Ramp 2</td> <td>8</td> </tr> </tbody> </table> | DI Parameter Function | DI1 (P263), DI2 (P264), DI3 (P265), DI4 (P266) | Not used | 0 | Not used (HMI) or General Enable (Terminals) | 1 | General Enable | 2 | JOG | 3 | Start/Stop | 4 | FWD/REV | 5 | Local/Remote | 6 | Multispeed | 7 | Multispeed with Ramp 2 | 8 |
| DI Parameter Function | DI1 (P263), DI2 (P264), DI3 (P265), DI4 (P266) | | | | | | | | | | | | | | | | | | | | | |
| Not used | 0 | | | | | | | | | | | | | | | | | | | | | |
| Not used (HMI) or General Enable (Terminals) | 1 | | | | | | | | | | | | | | | | | | | | | |
| General Enable | 2 | | | | | | | | | | | | | | | | | | | | | |
| JOG | 3 | | | | | | | | | | | | | | | | | | | | | |
| Start/Stop | 4 | | | | | | | | | | | | | | | | | | | | | |
| FWD/REV | 5 | | | | | | | | | | | | | | | | | | | | | |
| Local/Remote | 6 | | | | | | | | | | | | | | | | | | | | | |
| Multispeed | 7 | | | | | | | | | | | | | | | | | | | | | |
| Multispeed with Ramp 2 | 8 | | | | | | | | | | | | | | | | | | | | | |
| P264⁽¹⁾ Digital Input DI2 Function | 0 to 27 [5 - FWD/REV] - | | | | | | | | | | | | | | | | | | | | | |
| P265⁽¹⁾ Digital Input DI3 Function | 0 to 27 [6 - Local/Remote] - | | | | | | | | | | | | | | | | | | | | | |

Table 6.12 - DI's functions programming

| Parameter | Range [Factory Setting] | Description / Notes | |
|-------------------------------|---|----------------------------|---|
| | | DI Parameter | DI1 (P263), DI2 (P264), DI3 (P265), DI4 (P266) |
| P266⁽¹⁾ | 0 to 27 | | |
| Digital Input DI4 Function | [4 - Not used (HMI) or Start/Stop (Terminals)] | Function | |
| | | Forward run | 9 |
| | | Reverse Run | 10 |
| | | FWD with Ramp 2 | 11 |
| | | Reverse with Ramp 2 | 12 |
| | | Start | 13 |
| | | Stop | 14 |
| | | Activates Ramp 2 | 15 |
| | | Increase EP | 16 |
| | | Decrease EP | 17 |
| | | Accelerated EP with Ramp 2 | 18 |
| | | Decelerates EP with Ramp 2 | 19 |
| | | No external fault | 20 |
| | | Error reset | 21 |
| | | Start / Accelerate EP | 22 |
| | | Decelerate EP / Stop | 23 |
| | | Stop | 24 |
| | | Security Switch | 25 |
| | | Frequency Input | 26 |
| | | Manual / Automatic (PID) | 27 |

Table 6.12 (cont.) - DI's functions programming

Functions activated with 0 V at digital input.

NOTES!

- 1) Local/Remote = open/0 V at the digital input respectively.
- 2) P263 to P266 = 1 (not used or general enable) operates as follows:
 - if the command source are the terminals, i.e., if P229 = 1 for the local mode or P230 = 1 for the remote mode, the digital input selected operates as general enable;
 - otherwise, no function is assigned to the digital input.
- 3) P263 to P266 = 2 (general enable):
 - Regardless of the command source being the terminals or the keys, P229 = 0 or 1, or P230 = 0 or 1, the selected digital input works as general enable.
- 4) The selection of P263 to P266 = 16 / 17, P263 to P266 = 18/19 and/or, P263 to P266 = 22/23 requires the programming of P221 and/or P222 = 2.
- 5) The selection (P263 or P264) and/or P265 and/or P266 = 7 / 8 (multispeed) requires the programming of P221 and/or P222 = 6.

| Parameter | Range [Factory Setting] | Description / Notes |
|-----------|----------------------------|---|
| | | <p>6) When setting P263 to P266 = 26 it is necessary to set P221 and/or P222 = 7.</p> <p>7) P263 and P266 = 27 selection requires P203 = 1 to be programmed.</p> <p>8) If different acceleration and deceleration times are desired for a given operation condition (for instance for a set of frequencies or for a direction of rotation), check if it possible to use the multispeed function with Ramp 2 and FWD/REV with Ramp 2.</p> <p>9) Only one digital input can be programmed for each function. If more than one input has been programmed, programming error will be displayed (E24).</p> |

a) GENERAL ENABLE

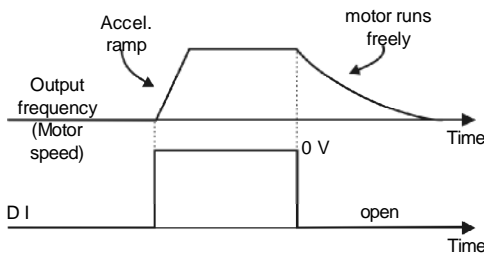

b) START/STOP

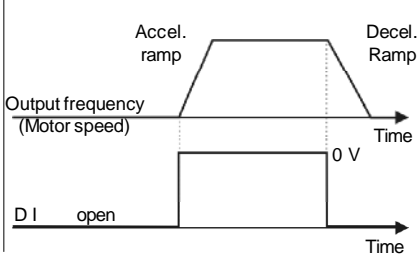

c) WIRE START/STOP

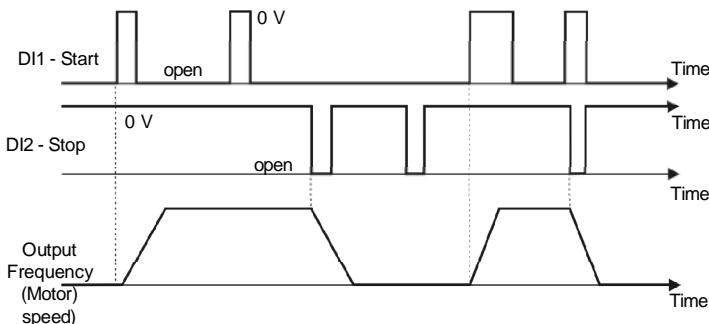
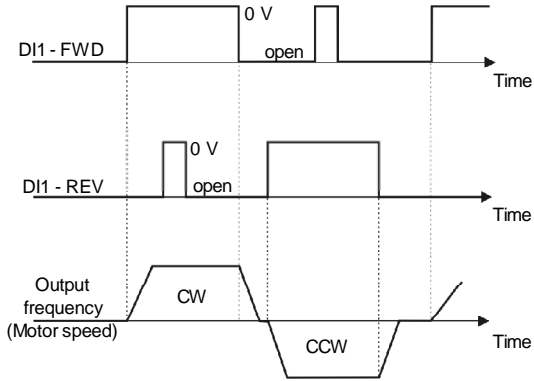
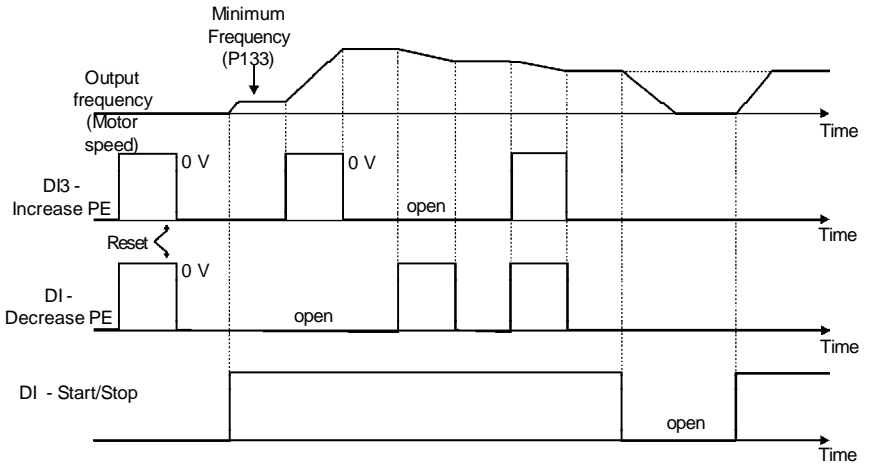

Figure 6.19 a) to c) - Details about the function of the digital inputs

d) FORWARD RUN / REVERSE RUN



e) ELECTRONIC POTENTIOMETER (EP)



f) FWD / REV

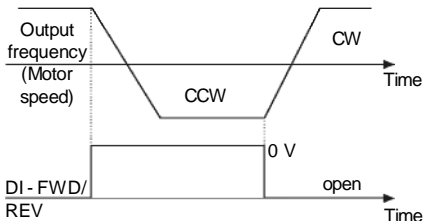

g) RAMP 2

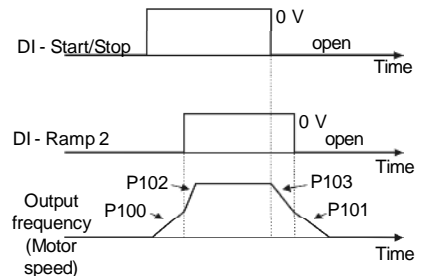
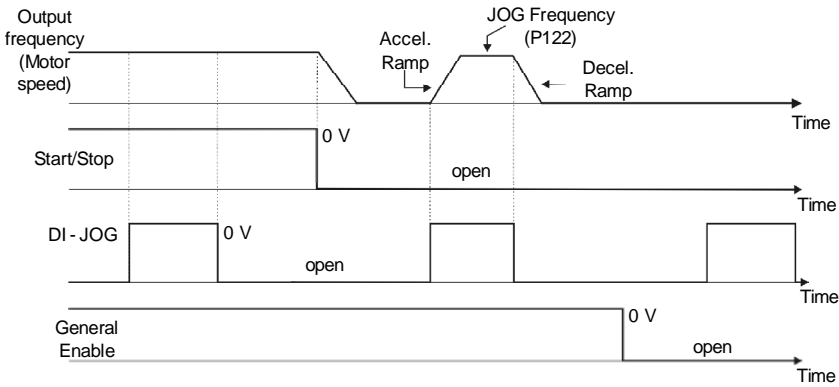
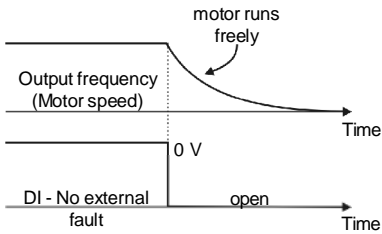

Figure 6.19 d) to f) - Details about the function of the digital inputs

h) JOG



i) NO EXTERNAL FAULT



j) ERROR RESET

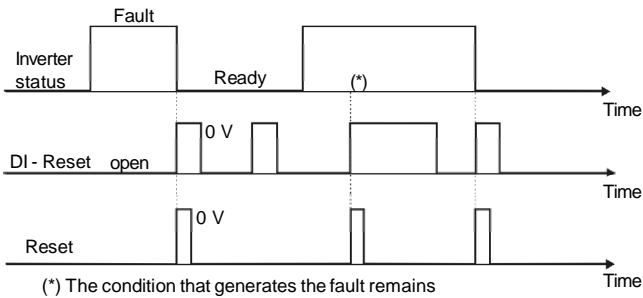
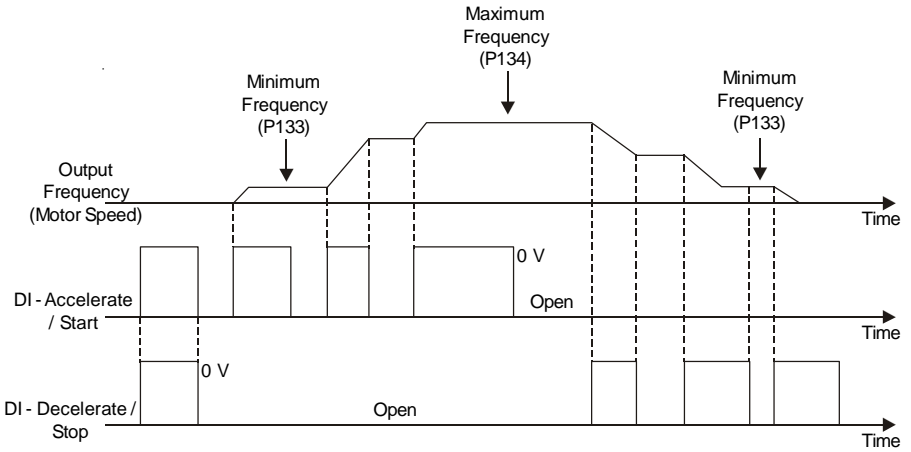
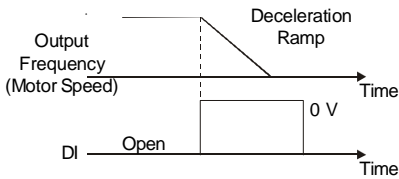

Figure 6.19 h) to j) - Details about the function of the digital inputs

**k) ELETRONIC POTENTIOMETER (EP)
(START/ACCELERATE) - (DECELERATE / STOP)**



l) STOP



m) SECURITY KEY

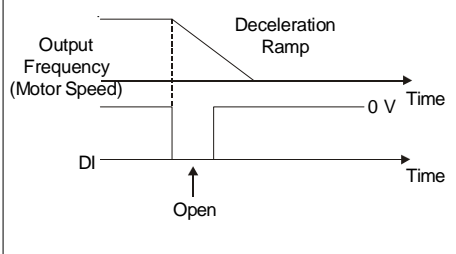

n) FREQUENCY INPUT

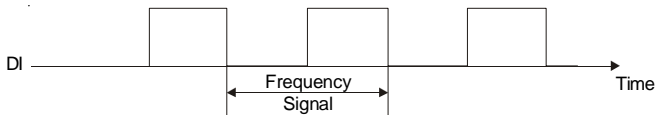

☑ Digital input signal frequency: 0.5 to 300 Hz.

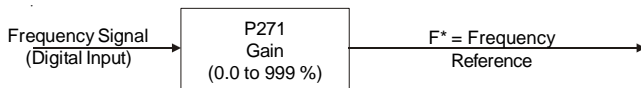

Figure 6.19 k) to n) - Details about the operation of the relay input functions

| Parameter | Range [Factory Setting] | Description / Notes | | | | | | | | | | | | | | | | |
|---|---|---|------------------------------|---------------|---------|---|---------|---|---------|---|---------|---|----------|---------|------------------------|---|----------|---|
| P271 Frequency Input Gain | 0.0 to 999 % [200] 0.1(< 100) 1(> 99.9) | <p><input checked="" type="checkbox"/> Defines the frequency input gain, according to the following equation:</p> $\text{Frequency Reference} = \left(\frac{\text{P271}}{100} \right) \times \text{Frequency Signal}$ <p>DI - Frequency Signal (Digital Input) → P271 GAIN → F* = Frequency Reference</p> <p><input checked="" type="checkbox"/> Digital input signal frequency: 0.5 to 300 Hz.</p> | | | | | | | | | | | | | | | | |
| P277⁽¹⁾ Relay Output RL1 Function | 0 to 7 [7 - No fault] | <p><input checked="" type="checkbox"/> Table below shows the available options.</p> <table border="1" style="margin-left: auto; margin-right: auto;"> <thead> <tr> <th>Output/Parameter Function</th> <th>P277 (RL1)</th> </tr> </thead> <tbody> <tr> <td>Fs > Fx</td> <td>0</td> </tr> <tr> <td>Fe > Fx</td> <td>1</td> </tr> <tr> <td>Fs = Fe</td> <td>2</td> </tr> <tr> <td>Is > Ix</td> <td>3</td> </tr> <tr> <td>Not used</td> <td>4 and 6</td> </tr> <tr> <td>Run (inverter enabled)</td> <td>5</td> </tr> <tr> <td>No fault</td> <td>7</td> </tr> </tbody> </table> | Output/Parameter Function | P277 (RL1) | Fs > Fx | 0 | Fe > Fx | 1 | Fs = Fe | 2 | Is > Ix | 3 | Not used | 4 and 6 | Run (inverter enabled) | 5 | No fault | 7 |
| Output/Parameter Function | P277 (RL1) | | | | | | | | | | | | | | | | | |
| Fs > Fx | 0 | | | | | | | | | | | | | | | | | |
| Fe > Fx | 1 | | | | | | | | | | | | | | | | | |
| Fs = Fe | 2 | | | | | | | | | | | | | | | | | |
| Is > Ix | 3 | | | | | | | | | | | | | | | | | |
| Not used | 4 and 6 | | | | | | | | | | | | | | | | | |
| Run (inverter enabled) | 5 | | | | | | | | | | | | | | | | | |
| No fault | 7 | | | | | | | | | | | | | | | | | |

Table 6.13 - Relay output functions

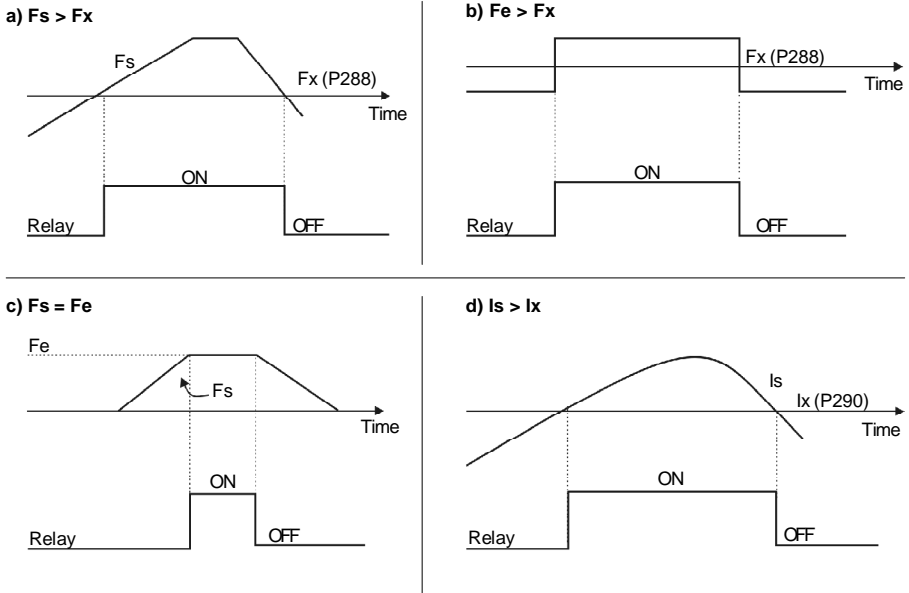

Figure 6.20 a) to d) - Details about the operation of the relay output functions

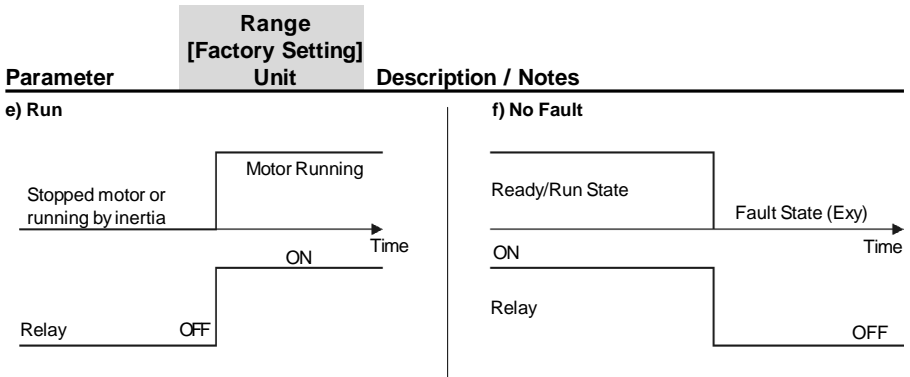

Figure 6.20 e) f) - Details about the operation of the relay output functions

| | | <ul style="list-style-type: none"> <input checked="" type="checkbox"/> When the definition in the function name is true, the digital output will be activated, i.e., the relay coil is energized. <input checked="" type="checkbox"/> When the option 'Not used' has been programmed, the relay output(s) will be disabled, i.e., the coil is not energized. <input checked="" type="checkbox"/> Definitions of the used symbols in the functions: Fs = P005 - output frequency (motor) Fe = Reference frequency (ramp input frequency) Fx = P288 - Fx frequency Is = P003 - output current (motor) Ix = P290 - Ix current | | | | | | | | | | | | | | |
|---|--|--|------|--|-----|-------|-----|-------|-----|-------|-----|-------|------|--------|------|--------|
| P288 Frequency Fx | 0.0 to P134 [3.0 Hz] 0.1 Hz (< 100 Hz); 1 Hz (> 99.9 Hz) | <input checked="" type="checkbox"/> Used in the relay output functions Fs > Fx, Fe > Fx e Is > Ix (see P277). | | | | | | | | | | | | | | |
| P290 Current Ix | 0 to 1.5 x P295 [1.0 x P295] 0.1 A | | | | | | | | | | | | | | | |
| P295 Inverter Rated Current (I _{nom}) | 1.6 to 10.0 [According to Inverter Rated Current] - | <table border="1"> <thead> <tr> <th>P295</th> <th>Inverter Rated Current (I_{nom})</th> </tr> </thead> <tbody> <tr> <td>1.6</td> <td>1.6 A</td> </tr> <tr> <td>2.6</td> <td>2.6 A</td> </tr> <tr> <td>4.0</td> <td>4.0 A</td> </tr> <tr> <td>7.3</td> <td>7.3 A</td> </tr> <tr> <td>10.0</td> <td>10.0 A</td> </tr> <tr> <td>15.2</td> <td>15.2 A</td> </tr> </tbody> </table> | P295 | Inverter Rated Current (I _{nom}) | 1.6 | 1.6 A | 2.6 | 2.6 A | 4.0 | 4.0 A | 7.3 | 7.3 A | 10.0 | 10.0 A | 15.2 | 15.2 A |
| P295 | Inverter Rated Current (I _{nom}) | | | | | | | | | | | | | | | |
| 1.6 | 1.6 A | | | | | | | | | | | | | | | |
| 2.6 | 2.6 A | | | | | | | | | | | | | | | |
| 4.0 | 4.0 A | | | | | | | | | | | | | | | |
| 7.3 | 7.3 A | | | | | | | | | | | | | | | |
| 10.0 | 10.0 A | | | | | | | | | | | | | | | |
| 15.2 | 15.2 A | | | | | | | | | | | | | | | |

Table 6.14 - Inverter rated current definition

| Parameter | Range [Factory Setting] Unit | Description / Notes | | | | | | | | | | | | | | | | | | | | | | | | | | | | | | | | | | | |
|---|--|--|--------------------------|------------------------|----------------------|-----------------------|------------------------|-----------|-------|-------|-------|-------|-----------|-------|-------|-------|-------|-----------|-------|-------|-------|-------|-----------|-------|-------|-------|-------|-----------|--------|--------|-------|-------|-----------|--------|--------|--------|--------|
| P297⁽¹⁾ Switching Frequency | 2.5 to 15.0 [5 kHz] 0.1 kHz For the 15.2 A model the factory adjustment is [2.5 kHz] | <ul style="list-style-type: none"> ☑ Defines the switching frequency of the IGBTs in the inverter. ☑ The switching frequency is a compromise between the motor acoustic noise level and the inverters IGBTs losses. Higher switching frequencies cause lower motor acoustic noise level, but increase the IGBTs losses, increasing the drive components temperature and thus reducing their useful life. ☑ The predominant frequency on the motor is twice the switching frequency set at P297. ☑ Thus, P297 = 5 kHz results in an audible motor noise corresponding to 10 kHz. This is due to the used PWM technique . ☑ The reduction of the switching frequency also contributes to the reduction of instability and resonance that may occur in certain application conditions, as well as reduces the emission of electromagnetic energy by the inverter. ☑ The reduction of the switching frequencies also reduces the leakage currents to ground. ☑ Use currents according to table below: <table border="1" style="margin-left: 20px; margin-top: 10px;"> <thead> <tr> <th>Inverter Model / P297</th> <th>2.5 kHz</th> <th>2.5 kHz a 5.0 kHz</th> <th>5.1 kHz a 10.0 kHz</th> <th>10.1 kHz a 15.0 kHz</th> </tr> </thead> <tbody> <tr> <td>CFW100016</td> <td>1.6 A</td> <td>1.6 A</td> <td>1.6 A</td> <td>1.6 A</td> </tr> <tr> <td>CFW100026</td> <td>2.6 A</td> <td>2.6 A</td> <td>2.6 A</td> <td>2.1 A</td> </tr> <tr> <td>CFW100040</td> <td>4.0 A</td> <td>4.0 A</td> <td>4.0 A</td> <td>3.4 A</td> </tr> <tr> <td>CFW100073</td> <td>7.3 A</td> <td>7.3 A</td> <td>6.8 A</td> <td>6.3 A</td> </tr> <tr> <td>CFW100100</td> <td>10.0 A</td> <td>10.0 A</td> <td>9.5 A</td> <td>9.0 A</td> </tr> <tr> <td>CFW100152</td> <td>15.2 A</td> <td>14.0 A</td> <td>12.0 A</td> <td>10.0 A</td> </tr> </tbody> </table> | Inverter Model / P297 | 2.5 kHz | 2.5 kHz a 5.0 kHz | 5.1 kHz a 10.0 kHz | 10.1 kHz a 15.0 kHz | CFW100016 | 1.6 A | 1.6 A | 1.6 A | 1.6 A | CFW100026 | 2.6 A | 2.6 A | 2.6 A | 2.1 A | CFW100040 | 4.0 A | 4.0 A | 4.0 A | 3.4 A | CFW100073 | 7.3 A | 7.3 A | 6.8 A | 6.3 A | CFW100100 | 10.0 A | 10.0 A | 9.5 A | 9.0 A | CFW100152 | 15.2 A | 14.0 A | 12.0 A | 10.0 A |
| Inverter Model / P297 | 2.5 kHz | 2.5 kHz a 5.0 kHz | 5.1 kHz a 10.0 kHz | 10.1 kHz a 15.0 kHz | | | | | | | | | | | | | | | | | | | | | | | | | | | | | | | | | |
| CFW100016 | 1.6 A | 1.6 A | 1.6 A | 1.6 A | | | | | | | | | | | | | | | | | | | | | | | | | | | | | | | | | |
| CFW100026 | 2.6 A | 2.6 A | 2.6 A | 2.1 A | | | | | | | | | | | | | | | | | | | | | | | | | | | | | | | | | |
| CFW100040 | 4.0 A | 4.0 A | 4.0 A | 3.4 A | | | | | | | | | | | | | | | | | | | | | | | | | | | | | | | | | |
| CFW100073 | 7.3 A | 7.3 A | 6.8 A | 6.3 A | | | | | | | | | | | | | | | | | | | | | | | | | | | | | | | | | |
| CFW100100 | 10.0 A | 10.0 A | 9.5 A | 9.0 A | | | | | | | | | | | | | | | | | | | | | | | | | | | | | | | | | |
| CFW100152 | 15.2 A | 14.0 A | 12.0 A | 10.0 A | | | | | | | | | | | | | | | | | | | | | | | | | | | | | | | | | |
| P300 DC Braking Time | 0.0 to 15.0 [0.0] 0.1 s | <ul style="list-style-type: none"> ☑ The DC braking feature provides a motor fast stop via DC current injection. ☑ The applied DC braking current, that is proportional to the braking torque, is set at P302. | | | | | | | | | | | | | | | | | | | | | | | | | | | | | | | | | | | |
| P301 DC Braking Start Frequency | 0.0 to 15.0 [1.0] 0.1 Hz | <ul style="list-style-type: none"> ☑ The figures below show the DC braking operation at the two possible conditions: ramp disabling and general disabling. | | | | | | | | | | | | | | | | | | | | | | | | | | | | | | | | | | | |
| P302 Braking Torque | 0.0 to 100 [50.0] 0.1 % | | | | | | | | | | | | | | | | | | | | | | | | | | | | | | | | | | | | |

Table 6.15 - Current values for values of P297

| Parameter | Range [Factory Setting] Unit | Description / Notes |
|-----------|------------------------------------|---------------------|
|-----------|------------------------------------|---------------------|

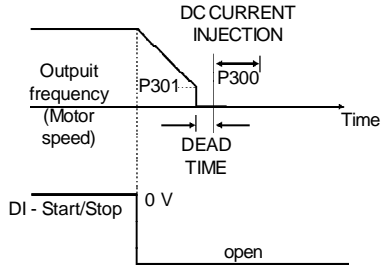

Figure 6.21 - DC braking after ramp disable

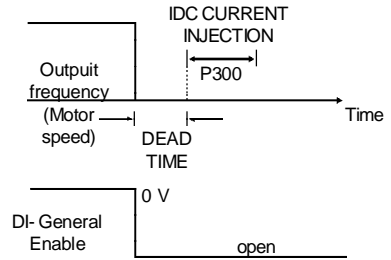

Figure 6.22 - DC braking after general disable

Before DC braking starts, there is a "Dead Time" (motor runs freely) required for the motor demagnetization. This time is function of the motor speed at which the DC braking occurs (output frequency).

During the DC braking the LED display flashes



If the inverter is enabled during the braking process, this process will be aborted and motor operates normally.

DC braking can continue its braking process even after the motor has stopped. Pay special attention to the dimensioning of the motor thermal protection for cyclic braking of short times.

In applications where the motor current is lower than the rated inverter current, and where the braking torque is not enough for the braking condition, please contact WEG to optimize the settings.

6.3.4 Special Functions Parameters – P500 to P599

6.3.4.1 Introduction

- ☑ Other application examples: level control, temperature, dosing, etc. The CFW-10 is fitted with PID regulator function that can be used for closed loop process control. This function works as a proportional, integral and derivative regulator which superimposes the normal inverter speed control.
- ☑ The speed will be changed in order to maintain the process variable (the one that want to be controlled – for example: water level of a reservoir) at the desired value, set at the reference (set point).
- ☑ For instance, a motor connected to a pump and driven by an inverter makes a fluid circulate into the piping. The inverter itself can make the flow control into the piping by means of the PID regulator. In this case, for example, the set point (flow) could be given by the input (HMI Potentiometer) or through P525 (digital set point) and the flow feedback signal would come to the analog AI1 input.
- ☑ Other application examples: level control, temperature, dosing, etc.

6.3.4.2 Description

- ☑ Figure 6.23 shows a schematic representation of PID regulator function.
- ☑ The feedback signal must come in the analog input AI1.
- ☑ The set point is the process variable value which desires to operate. This value is entered as percentage, and it is defined by the following equation:

$$\text{Setpoint (\%)} = \frac{\text{setpoint (UP)}}{\text{full scale of used sensor (UP)}} \times P234$$

Where both set point and full scale of the used sensor are given by the process unit (i.e., °C, bar, etc.).

Example: A pressure transducer (sensor) with 4 - 20 mA output and 25 bar full scale (i.e., 4 mA = 0 bar and 20 mA = 25 bar) and P234 = 200. If 10 bar is desired to control, the following set point should be entered:

$$\text{Setpoint (\%)} = \frac{10}{25} \times 200 = 80 \%$$

- ☑ The set point can be defined via:
 - Keypad: digital set point, P525 parameter.
 - Input (HMI potentiometer) (only available in the CFW-10 Plus): the percentage value is calculated based on P238 and P240 (see description of these parameters).

- ☑ The P040 parameter indicates the process variable value (feedback) in the selected scale at P528, which is set according to the following equation:

$$P528 = \frac{\text{full scale of used sensor}}{P234} \times 100$$

Example: Consider the previous example data (pressure sensor of 0 - 25 bar and P234 = 200). P528 must be set to $(25/200) \times 100 = 12.5$.

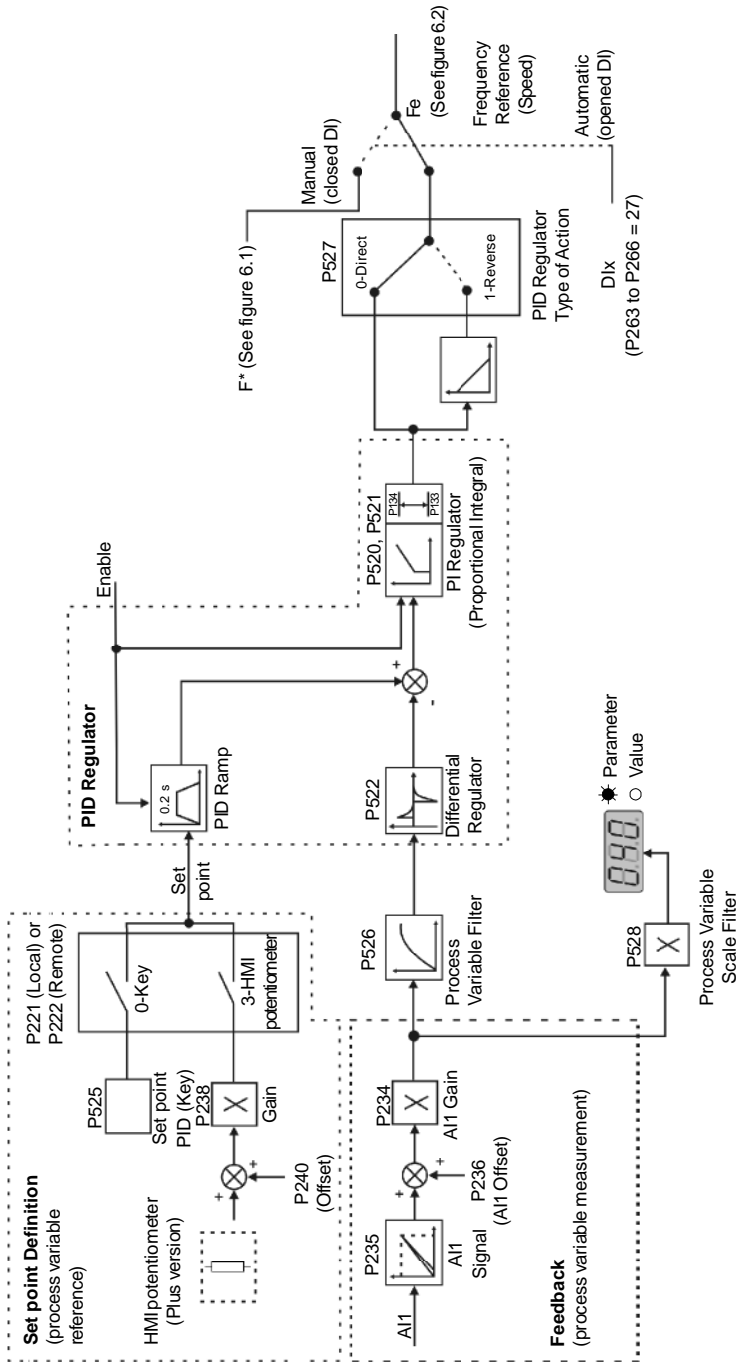

Figure 6.23 - PID regulator function block diagram



NOTE!

In case of none digital input has been selected for manual/automatic function, the PID always will work on the automatic condition.



NOTE!

When PID (P203 = 1) function is enabled:

- ☑ Program one of the digital inputs DIX (P263 to P266 = 27). In this manner, with closed DIX it operates in manual mode (without closing the loop control – feedback) and opening the DIX the PID regulator starts to operate (closed loop control – automatic mode). If there is no digital input (DIX) selected for manual/automatic function (P263 to P266 = 27), the inverter operation always will be in automatic mode.
- ☑ If P221 or P222 is equal to 1, 2, 4, 5, 6 or 7 there will be an E24 indication.
Set P221 and P222 equal to 0 or 3 as need.
- ☑ In manual mode the frequency reference is given by F* according to figure 6.1.
- ☑ When changed from manual to automatic, P525 = P040 is automatically set if P536 = 0 (at the moment immediately before the commutation). In this manner, if the set point is defined by P525 (P221 or P222 = 0) and changed from manual to automatic, P525 = P040 is automatically set, since P536 parameter is active (P536 = 0). In this case, the commutation from manual to automatic is smooth (there is no abrupt speed variation).
- ☑ The following figure 6.24 shows an application example of an inverter controlling a process in closed loop (PID regulator).

6.3.4.3 Start up Guide Find below a start-up procedure for the PID regulator:

Initial Definitions

- 1) Process - To define the PID type of action that the process requires: direct or reverse. The control action must be direct (P527 = 0) when it is required to increase the motor speed and so also increment the process variable. Otherwise select reverse (P527 = 1).

Examples:

- a) Direct: Pump driven by an inverter and filling a reservoir where the PID regulates the reservoir level. To increase the reservoir level (process variable) the flow must be increased and consequently also the motor speed must be increased.
- b) Reverse: Fan driven by an inverter to cool a cooling tower, with the PID controlling the tower temperature.
When it is required to increase the temperature (process variable), the cooling must be decreased by reducing the motor speed.

- 2) Feedback (process variable measurement):

It is always via analog input AI1.

- ☑ Transducer (sensor) to be used for the feedback of the control variable: it is recommended to use a full scale sensor with minimum 1.1 times higher than the largest value of the process variable that shall be controlled. Example: If a pressure control at 20 bar is desired, select a sensor with a control capacity of at least 22 bar.

- ☑ Signal type: set P235 according to transducer signal (4-20 mA, 0-20 mA or 0-10 V).

Set P234 according to the variation range of the used feedback signal (for more details see parameters descriptions P234 to P240).

Example: suppose the following application:

- Full scale of the transducer (maximum value at the transducer output) = 25 bar (FS = 25);
- Operation range (range of interest) = 0 to 15 bar (FO = 15).
Considering a safety margin of 10 %, the measuring range of the process variable must be set to: 0 to 16.5 bar.

Thus: FM = 1.1 x FS = 16.5.

In this manner, the P234 parameter must be set to:

$$P234 = \frac{FS}{FM} \times 100 = \frac{25}{16.5} \times 100 = 152$$

- ☑ As the operation range starts at zero, P236 = 0.
Thus, a set point of 100 % represents 16.5 bar, i.e., the operation range, in percentage is: 0 to 90.9 %.



NOTE!

In most of the cases it is not necessary to set the gain and the offset (P234 = 100 and P236 = 0.0). Thus, the percentage value of the set point is equivalent to the percentage value of the full scale used sensor. However, if the maximum resolution of the analog input AI1 (feedback) is desired, set P234 per previous explanation.

Setting of the display indication to the process variable measuring unit (P040): set P528 according to the full scale of the used transducer (sensor) and defined P234 (see the following description of parameter P528)

- 3) Reference (set point):
Local/remote mode.
Reference source: Set P221 or P222 according to last definition.
- 4) Speed Limits: Set P133 and P134 according to the application.

Start Up

- 1) Manual Operation (closed DI):
Display indication (P040): check indication based on external measurement and on the feedback signal (transducer) at AI1.
Vary the frequency reference (F*) until the desired value of the process variable is reached.
Only then switch to the automatic mode (inverter will set automatically P525 = P040), if P536 equal to zero.

- 2) Automatic Operation: open the DI and make the dynamic setting of the PID regulator, i.e., set the proportional gain (P520), integral gain (P521) and differential gain (P522).



NOTE!

The inverter setting must be correct in order to obtain a good performance of the PID regulator. Ensure the following settings:

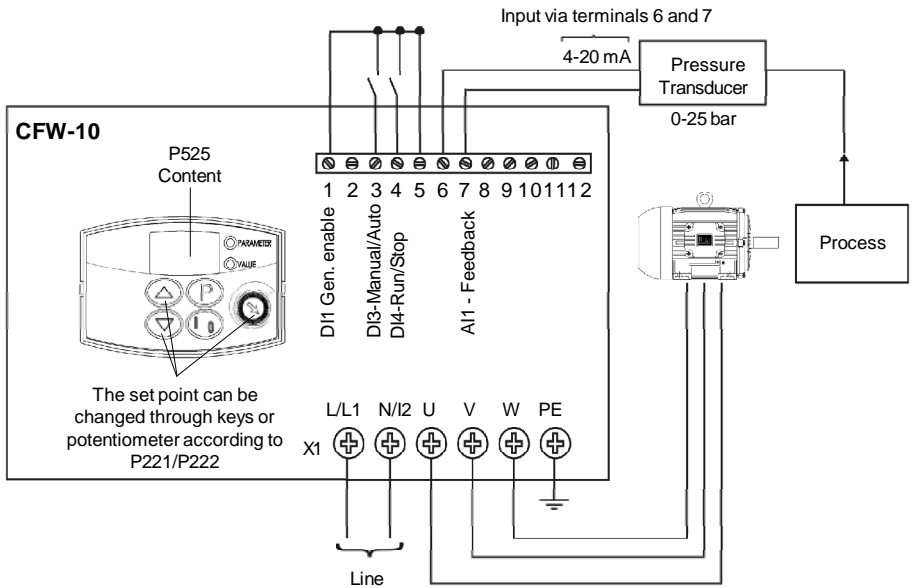

- Torque boosts (P136 and P137) and slip compensation (P138) in the V/F mode control (P202 = 0 or 1);
- Acceleration and deceleration ramps (P100 to P103);
- Current limitation (P169).



Inverter parameterization:

- | | |
|---------------|------------|
| P203 = 1 | P238 = 100 |
| P221 = 0 or 3 | P240 = 0 |
| P222 = 0 or 3 | P265 = 27 |
| P229 = 1 | P525 = 0 |
| P234 = 100 | P526 = 0.1 |
| P235 = 1 | P527 = 0 |
| P236 = 000 | P528 = 25 |

Figure 6.24 - Application example of an inverter with PID regulator

| Parameter | Range [Factory Setting] Unit | Description / Notes | | | | | | | | | | | | | | | |
|---|---|---|------|-------------|---|--------|---|---------|------------------------------|--------------------------------|-----------------|----------|-------------|------------|----------|------|------------|
| P520 PID Proportional Gain | 0.0 to 999 % [100] 0.1 (< 100) 1 (> 99.9) | <input checked="" type="checkbox"/> The integral gain can be defined as being the time required to vary the PI regulator output from 0 to P134, <input checked="" type="checkbox"/> That is given, in seconds, by the equation below: $t = \frac{1600}{P521.P525}$ | | | | | | | | | | | | | | | |
| P521 PID Integral Gain | 0.0 to 999 % [100] 0.1 (< 100) 1 (> 99.9) | For the following conditions: - P040 = P520 = 0; - Dix in automatic position. | | | | | | | | | | | | | | | |
| P522 PID Differential Gain | 0.0 to 999 % [0] 0.1 (< 100) 1 (> 99.9) | | | | | | | | | | | | | | | | |
| P525 PID Regulator Set point (Via Keys) | 0.0 to 100.0 % [0.0] 0.1 % | <input checked="" type="checkbox"/> Provides the set point (reference) of the process via keys  and  for PID regulator since P221 = 0 (local) or P222 = 0 (remote) and it has been set to automatic mode. If it has been set to manual mode the keys reference is provided by P121 <input checked="" type="checkbox"/> If P120 = 1 (active backup), the value of P525 is maintained at the last set value (backup), even when the inverter is disabled or not energized. | | | | | | | | | | | | | | | |
| P526 Process Variable Filter | 0.0 to 10.0 s [0.1 s] 0.1 | <input checked="" type="checkbox"/> Sets the time constant of the process variable filter. <input checked="" type="checkbox"/> It is useful for noise filtering at the analog input AI1 (feedback of the process variable). | | | | | | | | | | | | | | | |
| P527 Action Type of PID Regulator | 0 to 1 [0] - | <input checked="" type="checkbox"/> Defines the action type of the PID control. <table border="1" data-bbox="573 1117 753 1197" style="margin-left: auto; margin-right: auto;"> <thead> <tr> <th>P527</th> <th>Action Type</th> </tr> </thead> <tbody> <tr> <td>0</td> <td>Direct</td> </tr> <tr> <td>1</td> <td>Reverse</td> </tr> </tbody> </table> <p style="text-align: center;">Table 6.16 - PID action type configuration</p> <input checked="" type="checkbox"/> Select according to the table below: <table border="1" data-bbox="485 1316 868 1444" style="margin-left: auto; margin-right: auto;"> <thead> <tr> <th>Process variable requirement</th> <th>Increase Increase For this the</th> <th>P527 to be used</th> </tr> </thead> <tbody> <tr> <td>Increase</td> <td>motor speed</td> <td>1(Reverse)</td> </tr> <tr> <td>Decrease</td> <td>must</td> <td>0 (Direct)</td> </tr> </tbody> </table> <p style="text-align: center;">Table 6.17 - Options operation description for P527</p> | P527 | Action Type | 0 | Direct | 1 | Reverse | Process variable requirement | Increase Increase For this the | P527 to be used | Increase | motor speed | 1(Reverse) | Decrease | must | 0 (Direct) |
| P527 | Action Type | | | | | | | | | | | | | | | | |
| 0 | Direct | | | | | | | | | | | | | | | | |
| 1 | Reverse | | | | | | | | | | | | | | | | |
| Process variable requirement | Increase Increase For this the | P527 to be used | | | | | | | | | | | | | | | |
| Increase | motor speed | 1(Reverse) | | | | | | | | | | | | | | | |
| Decrease | must | 0 (Direct) | | | | | | | | | | | | | | | |

| Parameter | Range [Factory Setting] Unit | Description / Notes | | | | | | |
|--|--|--|------|----------|---|---|---|--|
| P528 Process Variable Scale Factor | 0.0 to 999 [100] 0.1(< 100) 1 (> 99.9) | <p><input checked="" type="checkbox"/> Defines the process variables scale. It makes the conversion between percentage value (internally used by the inverter) and the process variable unit</p> <p><input checked="" type="checkbox"/> P528 defines how the process variable at P040 will be showed: P040 = value % x P528.</p> <p><input checked="" type="checkbox"/> Set P528 in:</p> $P528 = \frac{\text{full scale of used sensor (FM)}}{P234} \times 100$ | | | | | | |
| P536 Automatic Setting of P525 | 0 to 1 [0] - | <p><input checked="" type="checkbox"/> Allows the user to enable/disable a copy of P040 (process variable) in P525, when there is a commutation of PID operation mode from manual to automatic.</p> <table border="1" data-bbox="579 647 1043 719"> <thead> <tr> <th>P536</th> <th>Function</th> </tr> </thead> <tbody> <tr> <td>0</td> <td>Active (copies the value of P040 in P525)</td> </tr> <tr> <td>1</td> <td>Inactive (does not copies the value of P040 in P525)</td> </tr> </tbody> </table> | P536 | Function | 0 | Active (copies the value of P040 in P525) | 1 | Inactive (does not copies the value of P040 in P525) |
| P536 | Function | | | | | | | |
| 0 | Active (copies the value of P040 in P525) | | | | | | | |
| 1 | Inactive (does not copies the value of P040 in P525) | | | | | | | |

Table 6.18 - P536 Configuration

DIAGNOSTICS AND TROUBLESHOOTING

7.1 FAULTS AND POSSIBLE CAUSES

This chapter assists the user to identify and correct possible faults that can occur during the CFW-10 operation. Also instructions about required periodical inspections and cleaning procedures are also provided.

When a fault is detected, the inverter is disabled and the fault code is displayed on the readout in E_{XX} form, where XX is the actual fault code.

To restart the inverter after a fault has occurred, the inverter must be reset. The reset can be made as follows:

- disconnect and reapply the AC power (power-on reset);
- press key  (manual reset);
- automatic reset through P206 (auto-reset);
- via digital input: DI1 to DI4 (P263 to P266 = 21).

The table below defines each fault code, explains how to reset the fault and shows the possible causes for each fault code.

| FAULT | RESET ⁽¹⁾ | POSSIBLE CAUSES |
|--|---|--|
| E00 Output Overcurrent (between phases) | <input checked="" type="checkbox"/> Power-on <input checked="" type="checkbox"/> Manual (key ) <input checked="" type="checkbox"/> Auto-Reset <input checked="" type="checkbox"/> DI | <input checked="" type="checkbox"/> Short-circuit between two motor phases. <input checked="" type="checkbox"/> If this fault occurs during power-up, there may be short-circuit between ground and one of more output phases. <input checked="" type="checkbox"/> Inertia of the load too high, or acceleration ramp too short. <input checked="" type="checkbox"/> P169 set too high. <input checked="" type="checkbox"/> Undue set of P136 and/or P137. <input checked="" type="checkbox"/> IGBT transistor module is short-circuited. |
| E01 DC Link Overvoltage | | <input checked="" type="checkbox"/> Power supply voltage too high, generating in the DC link a voltage higher than the allowed value: Ud > 410 V - Models 200-240 V Ud > 460 V - Models 110-127 V <input checked="" type="checkbox"/> Load inertia too high and acceleration ramp is too short <input checked="" type="checkbox"/> Setting of P151 too high. |
| E02 DC Link Undervoltage (Ud) | | <input checked="" type="checkbox"/> Power supply voltage too low, causing a DC link voltage higher than the allowed value (read the value at Parameter P004): Ud < 200 V - Modelos 200-240 V Ud < 250 V - Modelos 110-127 V |

| FAULT | RESET ⁽¹⁾ | POSSIBLE CAUSES |
|---|---|--|
| E04 Inverter Overtemperature | <input checked="" type="checkbox"/> Power-on <input checked="" type="checkbox"/> Manual (key ) <input checked="" type="checkbox"/> Auto-reset <input checked="" type="checkbox"/> DI | <input checked="" type="checkbox"/> Ambient temperature too high (> 50 °C), (> 40 °C for the 15.2 A model) and/or output current too high. <input checked="" type="checkbox"/> Blocked or defective fan. NOTE The heat sink overtemperature protection (E04) is activated when the heat sink temperature (P008) reaches 103 °C or 133 °C for the 15.2 A model. |
| E05 Overload at output I x t Function | | <input checked="" type="checkbox"/> P156 set too low for the motor that is being used. <input checked="" type="checkbox"/> Motor is under an actual overload condition. |
| E06 External Error (digital input progra for ext. fault is open) | | <input checked="" type="checkbox"/> Wiring at DI1 to DI4 inputs is open [not connected to GND (pin 5 of the XC1 control connector)]. |
| E08 CPU Error | | <input checked="" type="checkbox"/> Electrical noise. |
| E09 Program Memory Error (Checksum) | Contact WEG (refer to section 7.3) | <input checked="" type="checkbox"/> Memory with corrupted values. |
| E24 Programming error | It is automatically reset when the incompatible parameters are changed | <input checked="" type="checkbox"/> Incompatible parameters were programmed Refer to table 5.1. |
| E31 Keypad (HMI) Connection Fault | Contact WEG Servicing (Refer to section 7.3) | <input checked="" type="checkbox"/> Inverter control circuit is defective. <input checked="" type="checkbox"/> Electrical noise in the installation (electromagnetic interference). |
| E41 Self-Diagnosis Fault | Contact WEG Servicing (refer to section 7.3) | <input checked="" type="checkbox"/> Inverter power circuit is defective. |

Note:

(1) In case of E04 Fault due to inverter overtemperature, allow the inverter to cool down before trying to reset it.



NOTE!

The faults act as follows:

- E00 to E06: switches off the relay that has been programmed to “no fault”, disables the PWM pulses, displays the fault code on the display. Some data are saved on the EEPROM memory: keypad reference and EP (electronic potentiometer) (when the function “backup of the references” at P120 has been enabled), the occurred fault number, the status of the integrator of the I x t function (overcurrent).
- E24: Indicates the fault code on the LED display.
- E08, E09, E31 and E41: do not allow inverter operation (it is not possible to enable the inverter); the fault code is indicated on the LED display.

CHAPTER 7 - DIAGNOSTICS AND TROUBLESHOOTING

7.2 TROUBLESHOOTING

| PROBLEM | POINT TO BE CHECKED | CORRECTIVE ACTION |
|---------------------------------|--|--|
| Motor does not run | Incorrect wiring | 1.Check the power and the control connections. For example, the digital inputs Dlx programmed for Start/Stop or General Enable or No External Fault must be connected to GND (pin 5 of the control connector XC1). |
| | Analog reference (if used) | 1.Check if the external signal is properly connected. 2.Check the status of the speed potentiometer (if used). |
| | Incorrect programming | 1.Check if the parameters are properly programmed for the application. |
| | Fault | 1.Check if the inverter has not been disabled due to detected fault condition (refer to table above). |
| | Motor stall | 1.Reduce the motor load. 2.Increase P169 or P136/P137. |
| Motor speed oscillates | Loose connections | 1.Disable the inverter, switch OFF the power supply and tighten all connections. |
| | Defective speed potentiometer | 1.Replace the defective speed potentiometer. |
| | Variation of the external analog reference | 1.Identify the cause of the variation. |
| Motor speed too high or too low | Programming error (reference limits) | 1.Check if the contents of P133 (minimum frequency) and P134 (maximum frequency) are according to the motor and the application. |
| | Signal of the reference control | 1.Check the control signal level of the reference. 2.Check the programming (gains and offset) at P234 to P236. |
| | Motor nameplate | 1.Check if the used motor meets the application requirements. data. |
| Display OFF | Power supply | 1.The power supply must be within the following ranges: 200-240 V models: - Min: 170 V - Max: 264 V 110-127 V models: - Min: 93 V - Max: 140 V |

7.3 CONTACTING WEG



NOTE!

When contacting WEG for services, please have the following data on hand:

- Inverter model;
- Serial number, manufacturing date and hardware revision, as indicated on the inverter nameplate (refer to section 2.4);
- Software version (refer to section 2.2);
- Information about the application and inverter programming.

For further clarification, training or service, please, contact our Service Department:

7.4 PREVENTIVE MAINTENANCE



DANGER!

Always disconnect the power supply voltage before touching any component of the inverter.

Even after switching OFF the inverter, high voltages may be present. Wait 10 minutes to allow complete discharge of the power capacitors. Always connect the equipment frame to a suitable ground (PE) point.



ATTENTION!

Electronic boards have components sensitive to electrostatic discharges.

Never touch the components or connectors directly. If this is unavoidable, first touch the metallic frame or use a suitable ground strap.

Never apply a high voltage test on the inverter!
If this is necessary, contact WEG.

To avoid operation problems caused by harsh ambient conditions, such as high temperature, moisture, dirt, vibration or premature ageing of the components, periodic inspections of the inverter and installations are recommended.

CHAPTER 7 - DIAGNOSTICS AND TROUBLESHOOTING

| COMPONENTS | PROBLEMS | CORRECTIVE ACTIONS |
|--------------------------------------|------------------------------------|--------------------------------|
| Terminal blocks | Loose screws | Tighten them |
| | Loose connectors | |
| Printed circuit boards | Dust, oil or moisture accumulation | Clean them and/or replace them |
| | Smell | Replace them |
| Fans ⁽¹⁾ / Cooling System | Dirty fan | Clean fan |
| | Unusual acoustic noise | Change fan |
| | Stopped fan | |
| | Unusual vibration | |

(1) It is recommended to change the fans after 40.000 operation hours.

Table 7.1 - Periodic inspection after start-up

7.4.1 Cleaning Instructions

When required to clean the inverter, flow the instructions below:

a) Cooling System:

- Remove AC power from the inverter and wait 10 minutes.
- Remove all dust from ventilation openings by using a plastic brush or a soft cloth.
- Remove dust accumulated on the heatsink fins and from the blower blades with compressed air.

b) Electronic Boards:

- Remove AC power from the inverter and wait 10 minutes.
- Disconnect the inverter cables, ensuring that they are marked carefully to facilitate later reconnection.
- Remove all dust from the printed circuit boards by using an anti-static soft brush and/or remove it with an ionized compressed air gun; (for example: Charges Burtel Ion Gun (non nuclear) Ref. A6030-6 DESCO).

OPTIONS AND ACCESSORIES

This Chapter describes the optional devices that can be used internal or external with the CFW-10.



NOTE!

The CFW-10 inverter line has filters only for the models with single-phase power supply.

8.1 RFI FILTER

The installation of frequency inverters requires some care in order to prevent electromagnetic interferences (EMI).

This electromagnetic interference may disturb the operation of the inverter itself or other devices, such as electronic sensors, PLCs, transducers, radio equipment, etc. installed in the proximity.

To avoid these troubles, follow the installation instructions contained in this Manual.

In this case, avoid the installation of electromagnetic noise generating circuits, such as power cables, motors, etc. near to signal or control cables.

Care should also be taken with the radiated interference, by shielding the cables and the circuits that tend to emit electromagnetic waves and can cause interference.

The electromagnetic interference can also be transmitted through power supply line. This type of interference is minimized in the most cases by capacitive filters which are already installed inside the CFW-10.

However, when inverters are installed in residential areas, the installation of additional filter may be required.

These filters can be externally installed on the inverters. The class B filter has more attenuation than Class A filter as defined on EMC standard, being more suitable for residential environments. The existing filters and inverters models which apply are showed on table 3.5. The external filters must be installed between the power supply line and the inverters input, as further figure 8.1.

Instructions for the RFI filter installation:

- ☑ Install the inverter and the filter on a metallic grounded plate as near to each other as possible and ensure a good electrical contact between the grounded plate and the inverter and filter frames.
- ☑ For motor connection use a shielded cable or individual cables inside a grounded metallic conduit.

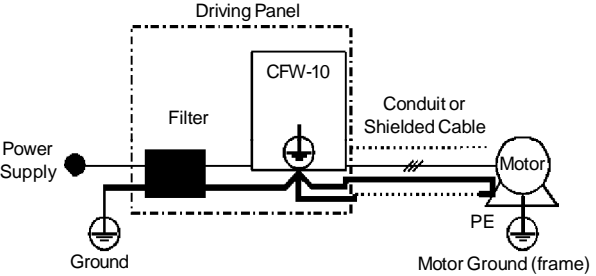

Figure 8.1 - Connection of the external RFI filter

8.2 LINE REACTOR

Due to the input circuit characteristic, common to the most inverters available on the market, consisting of a diode rectifier and a capacitor bank, the input current (drained from the power supply line) of inverters is a non sinusoidal waveform and contains harmonics of the fundamental frequency (frequency of the power supply: 60 Hz or 50 Hz). These harmonic currents circulate through the power supply line and cause harmonic voltage drops which distort the power supply voltage of the inverter and other loads connected to this line. These harmonic currents and voltage distortions may increase the electrical losses in the installation, overheating the components (cables, transformers, capacitor banks, motors, etc.), as well as lowering the power factor. The harmonic input currents depend on the impedance values that are present in the rectifier input/output circuit. The installation of a line reactor reduces the harmonic content of the input current, providing the following advantages:

- ☑ Increasing the input power factor;
- ☑ Reduction of the RMS input current;
- ☑ Reduction of the power supply voltage distortion;
- ☑ Increasing the life of the DC link capacitors.

8.2.1 Application Criteria

In a general manner, the CFW-10 series inverters can be connected directly to the power supply line without line reactors. But in this case, ensure the following:

- ☑ To ensure the inverter expected life, a **minimum line impedance** that introduces a voltage drop as shown in table 8.1, as a function of the motor load, is recommended. If the line impedance (transformers + wirings) is lower than these values, **it is recommended to use line reactor(s)**.
- ☑ When it is necessary to add a line reactor to the system, it is recommended to size it considering a 2 % to 4 % voltage drop (for nominal output current). This practice results in a compromise between motor voltage drop, power factor improvement and harmonic current distortion reduction.
- ☑ Always add a line reactor, when capacitors for power factor correction are installed in the same line and near to the inverter.
- ☑ Figure 8.2 shows the line reactor connection to the input.
- ☑ Use the following equation to calculate the value of the line reactor necessary to obtain the desired percentage of the voltage drop:

$$L = 1592 \cdot \Delta V \cdot \frac{V_e}{(f \cdot I_{e, nom})} \quad [\mu H]$$

where:

- ΔV - Desired line voltage drop, in percentage (%);
- V_e - Phase voltage at inverter input (line voltage), given in Volts (V);
- $I_{e, nom}$ - Input inverter rated current (refer to Chapter 9);
- f - Line frequency.

| Model | Minimum Line Impedance |
|--------------------|---|
| | Rated load at inverter output ($I_s = I_{s, nom}$) |
| 1.6 A / 200-240 V | 0.5 % |
| 2.6 A / 200-240 V | 0.5 % |
| 4.0 A / 200-240 V | 0.5 % |
| 7.3 A / 200-240 V | 1.0 % |
| 10.0 A / 200-240 V | 1.0 % |
| 15.2 A / 200-240 V | 2.0 % |
| 1.6 A / 110-127 V | 1.0 % |
| 2.6 A / 110-127 V | 2.0 % |
| 4.0 A / 110-127 V | 1.5 % |

Note: These values ensure a life of 20.000 hour for the DC link capacitors, i.e., they can be operated during 5 years with operation of 12 hours per day.

Table 8.1 - Minimum line impedance for several load conditions

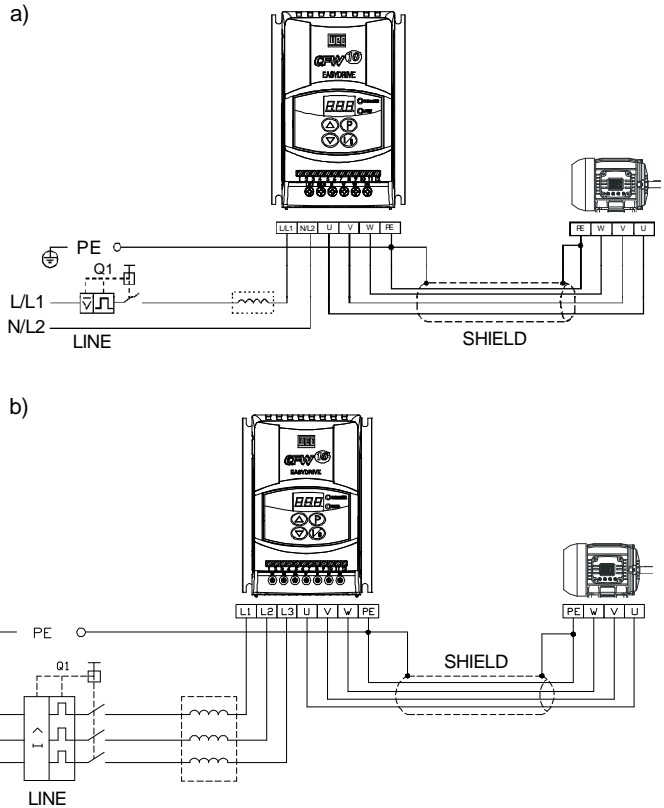

Figure 8.2 a) b) - Power connection with line reactor at the input

- ☑ As an alternative criterion, we recommend to add a line reactor always the transformer that supplies the inverter has rated output higher than indicated in table below:

| Inverter Model | Power of the Transformer [kVA] |
|--------------------------------------|--|
| 1.6 A and 2.6 A/200-240 V | 30 x rated apparent power of the inverter [kVA] |
| 4 A/200-240 V | 6 x rated apparent power of the inverter [kVA] |
| 1.6 A, 2.6 A and 4.0 A/ 110-127 V | 6 x rated apparent power of the inverter [kVA] |
| 7.3 A/220-240 V | 10 x rated apparent power of the inverter [kVA] |
| 10.0 A/200-240 V | 7.5 x rated apparent power of the inverter [kVA] |
| 15.2 A/200-240 V | 4 x rated apparent power of the inverter [kVa] |

Note: The value for the rated apparent power can be obtained in section 9.1 of this manual.

Table 8.2 - Alternative criteria for use of line reactor - Maximum values of the transformer power

8.3 LOAD REACTOR

The use of a three-phase load reactor, with an approximate 2 % voltage drop, adds an inductance at the inverter output to the motor. This decreases the dV/dt (voltage rising rate) of the pulses generated at the inverter output. This practice reduces the voltage spikes on the motor windings and the leakage currents that may be generated when long cables between inverter and motor (as a function of the "transmission line" effect) are used.

WEG Motor with voltages up to 460 V, no use of load reactor is required, since the insulation of the motor wires support the operation bi the CFW-10. If the cables between inverter and motor are longer than 100 m (330 ft), the cable capacitance to ground increases. In this case it is also recommended to use a load reactor.

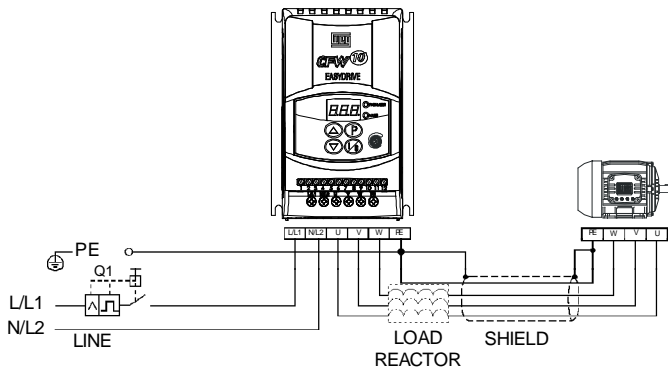

Figure 8.3 - Load Reactor Connection

8.4 RHEOSTATIC BRAKING

The rheostatic braking is used when short deceleration times are required or when high inertia loads are driven. For the correct braking resistor sizing the following application data shall be considered: deceleration time, load inertia, braking duty cycle, etc.

In any case, the RMS current capacity and the maximum peak current shall be respected.

The maximum peak current defines the minimum resistance value (ohms) of the braking resistor. Refer to table 8.3.

The DC Link voltage level at which the rheostatic braking is activated is the following:

CFW-10 200-240 V models: 366 Vdc

CFW-10 110-127 V models: 411 Vdc

8.4.1 Sizing

The braking torque that can be achieved through the application of frequency inverters, without using the rheostatic braking module, varies from 10 % to 35 % of the motor rated torque.

During the deceleration, the kinetic energy of the load is regenerated to the DC Link (intermediary circuitry). This regenerated energy charges the capacitors at the intermediary circuitry increasing the voltage level at the DC Link. In case this additional energy is not dissipated, an overvoltage error (E01) may occur disabling the inverter.

In order to have higher braking torques the rheostatic braking is applied. When using the rheostatic braking, the additional regenerated energy is dissipated in an external resistor. The braking resistor power is a function of the deceleration time, the load inertia and the resistive torque.

Use WIRE or RIBBON resistors in ceramic case with appropriated insulation voltage to withstand a high instantaneous power (respecting to the rated power).

| CFW-10 Model | V _{max} (Maximum Resistor Voltage) | Maximum Braking Current | P _{max} (Resistor Peak Power) | Maximum RMS Braking Current | P _{rms} (Resistor Maximum Power) | Recommended Resistor | Recommended Wiring |
|--------------------|--|-------------------------|---|-----------------------------|--|----------------------|------------------------------|
| SINGLE-PHASE | | | | | | | |
| 1.6 A / 200-240 V | Braking not available | | | | | | |
| 2.6 A / 200-240 V | | | | | | | |
| 4.0 A / 200-240 V | | | | | | | |
| 7.3 A / 200-240 V | 410 V | 11 A | 4.3 kW | 10 A | 3.9 kW | 39 (ohms) | 2.5 mm ² / 14 AWG |
| 10.0 A / 200-240 V | 410 V | 11 A | 4.3 kW | 10 A | 4.3 kW | 39 (ohms) | 2.5 mm ² / 14 AWG |
| 1.6 A / 110-127 V | Braking not available | | | | | | |
| 2.6 A / 110-127 V | | | | | | | |
| 4.0 A / 110-127 V | | | | | | | |

Table 8.3 - Recommended braking resistors

| CFW-10 Model | V _{max} (Maximum Resistor Voltage) | Maximum Braking Current | P _{max} (Resistor Peak Power) | Maximum RMS Braking Current | P _{rms} (Resistor Maximum Power) | Recommended Resistor | Recommended Wiring |
|-----------------------|--|-------------------------|---|-----------------------------|--|----------------------|---------------------------------|
| THREE-PHASE | | | | | | | |
| 1.6 A / 200-240 V | | | | | | | |
| 2.6 A / 200-240 V | | | | | | | |
| 4.0 A / 200-240 V | | | | | | | |
| 7.3 A / 200-240 V | | | | | | | |
| 10.0 A / 200-240 V | 410 V | 11 A | 4.3 kW | 10 A | 4.3 kW | 39 (ohms) | 2.5 mm ² / 14 AWG |
| 15.2 A / 200-240 V | 410 V | 11 A | 4.3 kW | 10 A | 4.3 kW | 39 (ohms) | 2.5 mm ² / 14 AWG |

Table 8.3 (cont.) - Recommended braking resistors



NOTE!

Data presented in table 8.3 were calculated for the maximum power admissible for the frequency converter. For smaller braking power, another resistor can be used according to the application.

8.4.2 Installation

- ☑ Connect the braking resistor between the +UD and BR power terminals (Refer to Section 3.2.1 and fig. 3.6);
- ☑ Make this connection with a twisted pair. Run this cable separately from any signal or control wire. Size the cable cross section according to the application, considering the maximum and RMS current;
- ☑ If the braking resistor is installed inside the inverter panel, the additional heat dissipated by the resistor shall be considered when defining the panel ventilation.



DANGER!

The internal braking circuitry of the inverter as well as the braking resistor may be damaged if they are not properly sized and/or if the input power supply exceeds the maximum admissible value. In this case, the only guaranteed method to avoid burning the resistor and to eliminate the risk of fire is the installation of a thermal overload relay in series with the resistor and/or the installation of a thermostat on the resistor body, wiring it in a way to disconnect the inverter power supply in case of overload, as shown below:

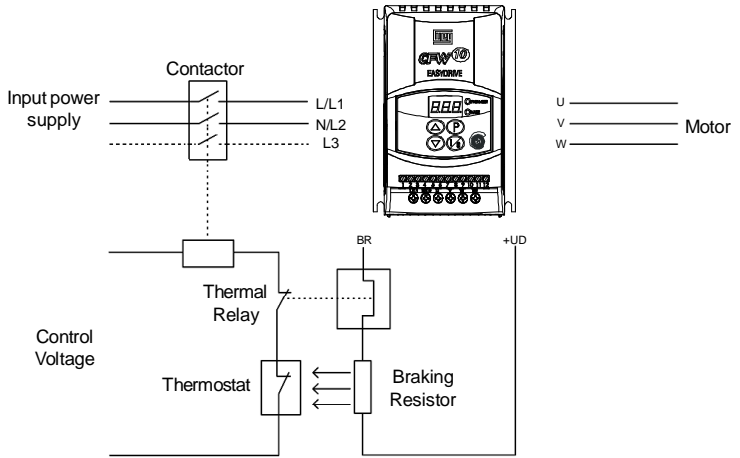

Figure 8.4 - Braking resistor connection (only for the models 7.3 and 10.0 A/200-240 V and 4.0 A/110-127 V single-phase and 10.0 A and 15.2 A/200-240 V three-phase)

TECHNICAL SPECIFICATIONS

This chapter describes the technical specifications (electrical and mechanical) of the CFW-10 inverter series.

- 9.1 POWER DATA** AC Input Specifications:
- Voltage: -15 %, +10 % (with loss of motor efficiency);
 - Frequency : 50/60 Hz (± 2 Hz);
 - Overvoltage: Category III (EN 61010/UL 508C);
 - Transient voltages according to Category III.

Minimum line impedance: variable according to inverter model. Refer to Section 8.2.

Power-up: max. 10 ON/OFF cycles per hour.

9.1.1 Power Supply: 200/240 V – Single-phase

| Model: Current (A) / Voltage (V) | 1.6/ 200-240 | 2.6/ 200-240 | 4.0/ 200-240 | 7.3/ 200-240 | 10.0/ 200-240 |
|---|---------------------|--------------------|------------------|-----------------|------------------|
| Power (kVA) ⁽¹⁾ | 0.6 | 1.0 | 1.5 | 2.8 | 3.8 |
| Rated Output Current (A) ⁽²⁾ | 1.6 | 2.6 | 4.0 | 7.3 | 10.0 |
| Max. Output Current (A) ⁽³⁾ | 2.4 | 3.9 | 6.0 | 11.0 | 15.0 |
| Power Supply | Single-phase | | | | |
| Rated Input Current (A) | 3.5 | 5.7 | 8.8 | 16.0 | 22.0 |
| Switching Frequency (kHz) | 10 | 10 | 10 | 5 | 5 |
| Max. Motor Output (CV) ^{(4) (5)} | 0.25 HP/ 0.18 kW | 0.5 HP/ 0.37 kW | 1 HP/ 0.75 kW | 2 HP/ 1.5 kW | 3 HP/ 2.2 kW |
| Watt Losses (W) | 30 | 35 | 50 | 90 | 100 |
| Rheostatic Braking | No | No | No | Yes | Yes |

9.1.2 Power Supply: 200/240 V – Three-phase

| Model: Current (A) / Voltage (V) | 1.6/ 200-240 | 2.6/ 200-240 | 4.0/ 200-240 | 7.3/ 200-240 | 10.0/ 200-240 | 15.2/ 200-240 |
|--|---------------------|--------------------|------------------|-----------------|------------------|------------------|
| Power (kVA) ⁽¹⁾ | 0.6 | 1.0 | 1.5 | 2.8 | 3.8 | 5.8 |
| Rated Output Current (A) ⁽²⁾ | 1.6 | 2.6 | 4.0 | 7.3 | 10.0 | 15.2 |
| Max. Output Current (A) ⁽³⁾ | 2.4 | 3.9 | 6.0 | 11.0 | 15.0 | 22.8 |
| Power Supply | Three-phase | | | | | |
| Rated Input Current (A) | 2.0 | 3.1 | 4.8 | 8.6 | 12.0 | 18.0 |
| Switching Frequency (kHz) | 10 | 10 | 10 | 5 | 5 | 2.5 |
| Max. Motor Power (CV) ^{(4) (5)} | 0.25 HP/ 0.18 kW | 0.5 HP/ 0.37 kW | 1 HP/ 0.75 kW | 2 HP/ 1.5 kW | 3 HP/ 2.2 kW | 5 HP/ 3.7 kW |
| Watt Losses (W) | 30 | 35 | 50 | 90 | 100 | 160 |
| Rheostatic Braking | No | No | No | No | Yes | Yes |

9.1.3 Power Supply: 110/127 V – Single-phase

| Model: Current/Voltage (V) | 1.6/ 110-127 | 2.6/ 110-127 | 4.0/ 100-127 |
|--|---------------------|--------------------|------------------|
| Power (kVA) ⁽¹⁾ | 0.6 | 1.0 | 1.5 |
| Rated Output Current (A) ⁽²⁾ | 1.6 | 2.6 | 4.0 |
| Max. Output Current (A) ⁽³⁾ | 2.4 | 3.9 | 6.0 |
| Power Supply | Single-Phase | | |
| Rated Input Current (A) | 7.1 | 11,5 | 17.7 |
| Switching Frequency (kHz) | 10 | 10 | 10 |
| Max. Motor Power (cv) ^{(4) (5)} | 0.25 HP/ 0.18 kW | 0.5 HP/ 0.37 kW | 1 HP/ 0.75 kW |
| Watt Losses (W) | 40 | 45 | 60 |
| Rheostatic Braking | No | No | Yes |



NOTE!

(1) The power rating in kVA is determined by the following equation:

$$P \text{ (kVA)} = \frac{\sqrt{3} \cdot \text{Voltage (V)} \cdot \text{Current (A)}}{1000}$$

The values shown in the table were calculated by considering the rated inverter current, input voltage of 220 V.

(2) Rated current is valid for the following conditions:

- ☑ Relative air humidity: 5 % to 90 %, non condensing.
- ☑ Altitude: 1000 m up to 4000 m (3.300 ft up to 13.200 ft) – current derating of 1 % for each 100 m (330 ft) above 1000 m (3.300 ft) altitude.
- ☑ Ambient temperature: 0 °C to 50 °C (32 °F to 122 °F). For the 15.2 A model and models with Built-in filter the temperature is 0 to 40 °C (32 °F to 104 °F).
The rated current values are valid for the switching frequencies of 2.5 kHz to 10 kHz (factory setting = 5 kHz, 2.5 kHz for the 15.2 A model).
- ☑ For higher switching frequencies, 10.1 kHz to 15 kHz, consider the values shown in the description of the parameter P297 (refer to chapter 6).

(3) Maximum Current:

- ☑ Inverter supports an overload of 50 % (maximum output current = 1.5 x the rated output current) during 1 minute for each 10 minutes of operation.
- ☑ For higher switching frequencies, 10.1 kHz up to 15 kHz, consider 1.5 times the value showed in parameter description P297 (see chapter 6).

(4) The indicated motor power ratings are only orientative values for IV-pole motors and normal duty loads. The precise inverter sizing must consider the actual motor nameplate and application data.

CHAPTER 9 - TECHNICAL SPECIFICATIONS

- (5) WEG inverters are supplied with parameter settings for WEG IV pole standard motors, 60 Hz, 220 V and outputs as indicated above.

9.2 ELECTRONIC/GENERAL DATA

| | | |
|-------------------------|------------------|--|
| CONTROL | METHOD | <input checked="" type="checkbox"/> Applied Voltage V/F (scalar) |
| | OUTPUT FREQUENCY | <input checked="" type="checkbox"/> 0 to 300 Hz, resolution: 0.01 Hz. |
| PERFORMANCE | V/F CONTROL | <input checked="" type="checkbox"/> Speed regulation: 1 % of the rated speed. |
| INPUTS (CCP10 Board) | ANALOG | <input checked="" type="checkbox"/> 1 isolated input, resolution: 7 bits, (0 to 10) V or (0 to 20) mA, or (4 to 20) mA, Impedance: 100 k Ω [(0 to 10) V], 500 Ω [(0 to 20) mA or (4 to 20) mA], programable function. |
| | DIGITAL | <input checked="" type="checkbox"/> 4 isolated digital inputs, 12 Vdc, programmable functions. |
| OUTPUT (CCP10 Board) | RELAY | <input checked="" type="checkbox"/> 1 relay with reverse contacts, (250 Vac - 0.5 A/ 125 Vac 1.0 A/ 30 Vdc 2.0 A), programmable functions. |
| SAFETY | PROTECTION | <input checked="" type="checkbox"/> Overcurrent/output short-circuit <input checked="" type="checkbox"/> Undervoltage and overvoltage at the power part <input checked="" type="checkbox"/> Inverter overtemperature <input checked="" type="checkbox"/> Motor/inverter overload (I xt) <input checked="" type="checkbox"/> External fault <input checked="" type="checkbox"/> Programming error <input checked="" type="checkbox"/> Defective inverter |
| KEYPAD (HMI) | STANDARD HMI | <input checked="" type="checkbox"/> 4 keys: start/stop, increment, decrement and programming, <input checked="" type="checkbox"/> LEDs display: 3 digits with 7 segments <input checked="" type="checkbox"/> LEDs for Parameter and its Conctent Indication <input checked="" type="checkbox"/> It permits access/alteration of all parameters <input checked="" type="checkbox"/> Display accuracy: - current: 10 % of the rated current - voltage resolution: 1 V - frequency resolution: 0.1 Hz - 1 potentiometer for the output frequency variation (available only in the Plus version) |
| DEGREE OF PROTECTION | IP20 | <input checked="" type="checkbox"/> For all models |
| STANDARDS | IEC 146 | <input checked="" type="checkbox"/> Inverters and semiconductors |
| | UL 508 C | <input checked="" type="checkbox"/> Power Conversion Equipment |
| | EN 50178 | <input checked="" type="checkbox"/> Electronic equipment for use in power installations |
| | EN 61010 | <input checked="" type="checkbox"/> Safety requirements for electrical equipment for measurement, control and laboratory use |
| | EN 61800-3 | <input checked="" type="checkbox"/> EMC product standard for adjustable speed electrical power drive systems, (with external filter) |