

# PUMP GENIUS

## Simplex

### CFW-11

#### Application Manual

Language: English  
Document: 10003799455 / 00

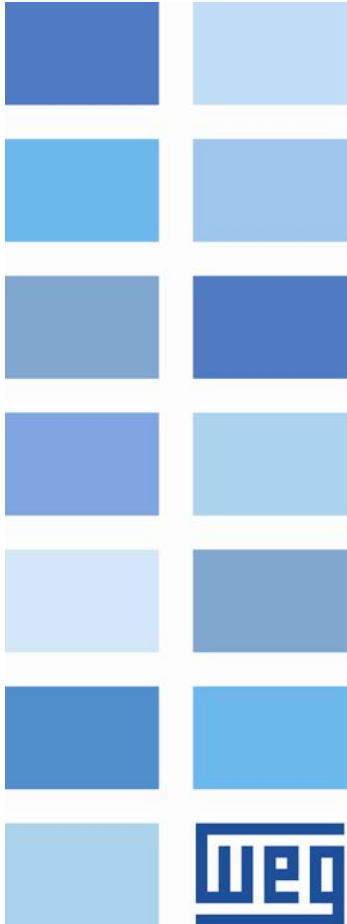





# **Pump Genius Simplex Application Manual**

Series: CFW-11

Language: English

Document Number: 10003799455 / 00

Publication Date: 09/2015

# CONTENTS

- ABOUT THE MANUAL ..... 6**
  - ABBREVIATIONS AND DEFINITIONS ..... 6
  - NUMERICAL REPRESENTATION ..... 6
- QUICK PARAMETER REFERENCE, FAULTS AND ALARMS ..... 7**
- 1 INTRODUCTION TO THE PUMP GENIUS SIMPLEX APPLICATION..... 12**
  - 1.1 PUMPS ..... 12
    - 1.1.1 Centrifugal Pumps.....12
    - 1.1.2 Positive Displacement Pumps .....12
  - 1.2 GENERAL CHARACTERISTICS OF THE PUMP GENIUS SIMPLEX APPLICATION ..... 13
- 2 PUMP GENIUS SIMPLEX CONFIGURATION ..... 14**
  - 2.1 CONTROL SETPOINT VIA HMI ..... 14
  - 2.2 CONTROL SETPOINT VIA ANALOG INPUT ..... 16
  - 2.3 CONTROL SETPOINT VIA LOGICAL COMBINATION OF THE DIGITAL INPUTS DI4 AND DI5..... 18
  - 2.4 CONTROL SETPOINT ACCORDING TO WEEKLY SCHEDULE..... 20
  - 2.5 SELECTION OF PID CONTROLLER IN MANUAL OR AUTOMATIC VIA DIGITAL INPUT DI3 ..... 22
  - 2.6 EXTERNAL PUMP FOR JOCKEY PUMP FUNCTION ..... 24
  - 2.7 PUMP PROTECTION VIA EXTERNAL SENSOR IN THE DIGITAL INPUT DI6 ..... 26
  - 2.8 PUMP PROTECTION VIA CONTROL AUXILIARY VARIABLE..... 28
  - 2.9 DERAGGING FUNCTION WITH COMMAND VIA DIGITAL INPUT DI2..... 30
- 3 PARAMETERS DESCRIPTION ..... 32**
  - 3.1 ORIGIN OF COMMANDS ..... 32
  - 3.2 RAMPS ..... 33
  - 3.3 SPEED LIMITS ..... 33
  - 3.4 DIGITAL INPUTS..... 34
  - 3.5 DIGITAL OUTPUTS..... 36
  - 3.6 ANALOG INPUTS..... 37
  - 3.7 CONTROL PROCESS VARIABLE..... 39
    - 3.7.1 Engineering Unit Configuration .....40
    - 3.7.2 Sensor Scale Configuration.....41
  - 3.8 CONTROL SETPOINT ..... 42
  - 3.9 WEEKLY SCHEDULE ..... 44
    - 3.9.1 Operation with Schedules 1 to 12 from Monday to Sunday (P1063=1) .....49
    - 3.9.2 Operation with Schedules 1 to 6 from Monday to Friday and Schedules 7 to 12 on Saturday and Sunday (P1063=2).....50
    - 3.9.3 Operation with Schedules 1 to 4 from Monday to Friday and Schedules 5 to 8 on Saturday and Schedules 9 to 12 on Sunday (P1063=3).....54
  - 3.10 PID CONTROLLER ..... 58
  - 3.11 STARTUP MODES ..... 61
    - 3.11.1 Wake up and Start Level Mode.....61
    - 3.11.2 Sleep Mode and Sleep Boost.....62
  - 3.12 PIPE CHARGING ..... 67
  - 3.13 EXTERNAL PUMP ..... 70
  - 3.14 LOW LEVEL PROTECTION FOR THE CONTROL PROCESS VARIABLE (PIPE BREAKING) ..... 72
  - 3.15 HIGH LEVEL PROTECTION FOR THE CONTROL PROCESS VARIABLE (PIPE OBSTRUCTION) ..... 73
  - 3.16 DRY PUMP PROTECTION ..... 74
  - 3.17 PUMP PROTECTION VIA EXTERNAL SENSOR ..... 76
  - 3.18 CONTROL AUXILIARY VARIABLE FOR PUMP PROTECTION ..... 76
    - 3.18.1 Engineering Unit Configuration .....77
    - 3.18.2 Sensor Scale Configuration.....79
    - 3.18.3 Pump Protection Configuration.....80

<b>3.19 DERAGGING FUNCTION .....</b>	<b>82</b>
<b>3.19.1 Deragging with Command to Run the Pump (P1052=1) .....</b>	<b>84</b>
<b>3.19.2 Deragging with Command via Digital Input DI2 (P1052=2) .....</b>	<b>85</b>
<b>3.19.3 Deragging when Clogging of Pump is detected (P1052=3).....</b>	<b>87</b>
<b>3.20 HMI MONITORING .....</b>	<b>89</b>
<b>3.21 READING PARAMETERS .....</b>	<b>90</b>
<b>4 CREATION AND DOWNLOAD THE APPLICATION .....</b>	<b>92</b>
<b>5 APPLICATION CONFIGURATION WIZARD.....</b>	<b>97</b>
<b>6 DOWNLOAD DIALOG BOXES.....</b>	<b>109</b>
<b>7 MONITORING DIALOG BOXES .....</b>	<b>110</b>
<b>8 TREND VARIABLES DIALOG BOXES.....</b>	<b>119</b>
<b>9 PARAMETER VALUE DIALOG .....</b>	<b>121</b>

# ABOUT THE MANUAL

This manual provides the necessary information for the configuration of a Pump Genius Simplex (One Pump) application developed with the CFW-11 inverter SoftPLC function. This application manual must be used together with the CFW-11 user's manual, the SoftPLC function manual and the WLP software manual.

## ABBREVIATIONS AND DEFINITIONS

<b>PLC</b>	Programmable Logic Controller
<b>CRC</b>	Cycling Redundancy Check
<b>RAM</b>	Random Access Memory
<b>USB</b>	Universal Serial Bus
<b>WLP</b>	Ladder Language Programming Software

## NUMERICAL REPRESENTATION

Decimal numbers are represented by means of digits without suffix. Hexadecimal numbers are represented with the letter 'h' after the number.



## QUICK PARAMETER REFERENCE, FAULTS AND ALARMS

Parameter	Description	Adjustable Range	Factory Setting	User Setting	Properties	Groups	Page
P1010	Pump Genius Simplex Application Version	0.00 to 10.00			ro	50	90
P1011	Control Setpoint	-32768 to 32767 [Eng. Un. 1]	200		rw	50	42
P1012	Control Setpoint 1	-32768 to 32767 [Eng. Un. 1]	200			50	43
P1013	Control Setpoint 2	-32768 to 32767 [Eng. Un. 1]	230			50	43
P1014	Control Setpoint 3	-32768 to 32767 [Eng. Un. 1]	180			50	43
P1015	Control Setpoint 4	-32768 to 32767 [Eng. Un. 1]	160			50	43
P1016	Control Process Variable	-32768 to 32767 [Eng. Un. 1]			ro	50	90
P1017	Control Auxiliary Variable	0 to 32767 [Eng. Un. 2]			ro	50	90
P1018	Setpoint of the PID Controller in Manual Mode	0 to 18000 rpm	0 rpm			50	58
P1019	Pump Genius Simplex Logical Status	Bit 0 = Sleep Mode Active (A750) Bit 1 = Pipe Charging (A752) Bit 2 = Sleep Boost Active (A756) Bit 3 = Low Level PV (A770) Bit 4 = Low Level PV (F771) Bit 5 = High Level PV (A772) Bit 6 = High Level PV (F773) Bit 7 = Low Level Auxiliary Variable (A774) Bit 8 = Dry Pump (A780) Bit 9 = Dry Pump (F781) Bit 10 = External Sensor Protection (A782) Bit 11 = External Sensor Protection (F783) Bit 12 = External Pump Running Bit 13 = Deragging in Execution (A794) Bit 14 = Pump Clogging detected (A790) Bit 15 = Excess of Clogging (F791)			ro	50	90
P1020	Control Setpoint Selection Source	1 = Setpoint via Analog Input AI1 2 = Setpoint via Analog Input AI2 3 = Setpoint via Analog Input AI3 4 = Setpoint via Analog Input AI4 5 = Setpoint via HMI or Communication Networks (P1011) 6 = Two Setpoints via Digital Input DI4 (P1012 and P1013) 7 = Three Setpoints via Digital Inputs DI4 and DI5 (P1012, P1013 and P1014) 8 = Four Setpoints via Digital Inputs DI4 and DI5 (P1012, P1013, P1014 and P1015) 9 = Setpoint according to Weekly Schedule	5			50	43
P1021	Control Process Variable Selection Source	0 = Without Control Process Variable (Disable the PID Controller) 1 = Control Process Variable via Analog Input AI1 2 = Control Process Variable via Analog Input AI2 3 = Control Process Variable via difference between Analog Input AI1 and AI2 (AI1 – AI2) 4 = Control Process Variable via Analog Input AI3 5 = Control Process Variable via Analog Input AI4	1			50	39

## Quick Parameter Reference, Faults and Alarms



Parameter	Description	Adjustable Range	Factory Setting	User Setting	Properties	Groups	Page
P1022	Control Process Variable Sensor Minimum Level	-32768 to 32767 [Eng. Un. 1]	0			50	41
P1023	Control Process Variable Sensor Maximum Level	-32768 to 32767 [Eng. Un. 1]	400			50	42
P1024	Value for Low Level Alarm for the Control Process Variable	-32768 to 32767 [Eng. Un. 1]	100			50	72
P1025	Time Delay for Low Level Fault for the Control Process Variable (F771)	0 to 32767 s	0 s			50	73
P1026	Value for High Level Alarm for the Control Process Variable	-32768 to 32767 [Eng. Un. 1]	350			50	73
P1027	Time Delay for High Level Fault for the Control Process Variable (F773)	0 to 32767 s	0 s			50	73
P1028	Selection of Control Action of the PID Controller	0 = Disable the PID Controller 1 = Direct Mode 2 = Reverse Mode	1			50	58
P1029	Operation Mode of the PID Controller	0 = Manual 1 = Automatic 2 = Manual or Automatic Selection via DI3	1			50	59
P1030	Automatic Adjustment of the PID Controller Setpoint	0 = P1011 Off and P1018 Off 1 = P1011 On and P1018 Off 2 = P1011 Off and P1018 On 3 = P1011 On and P1018 On	0			50	60
P1031	PID Proportional Gain	0.000 to 32.000	1.000			50	60
P1032	PID Integral Gain	0.000 to 32.000	5.000			50	60
P1033	PID Derivative Gain	0.000 to 32.000	0.000			50	61
P1034	Control Process Variable Deviation to Wake up the Pump Genius	-32768 to 32767 [Eng. Un. 1]	30			50	61
P1035	Control Process Variable Level for Starting the Pump Genius	-32768 to 32767 [Eng. Un. 1]	180			50	61
P1036	Time Delay to Wake up or Starting by Level the Pump Genius	0 to 32767 s	5 s			50	62
P1037	Pump Motor Speed below which Pump Genius goes to Sleep Mode	0 to 18000 rpm	1250 rpm			50	62
P1038	Time Delay for Pump Genius goes to Sleep Mode	0 to 32767 s	10 s			50	63
P1039	Sleep Boost Offset	-32768 to 32767 [Eng. Un. 1]	0			50	63
P1040	Sleep Boost Maximum Time	0 to 32767 s	15 s			50	63
P1041	Pipe Charging Time	0 to 65535 s	30 s			50	68
P1042	Maximum Output Current during the Pipe Charging	0.0 to 3200.0 A	0.0 A			50	68
P1043	Motor Speed for Dry Pump	0 to 18000 rpm	1650 rpm			50	74
P1044	Motor Torque for Dry Pump	0.0 to 100.0 %	20.0 %			50	74
P1045	Time Delay for Dry Pump Fault (F781)	0 to 32767 s	0 s			50	74
P1046	Time Delay for Pump Protection via External Sensor Fault (F783)	0 to 32767 s	2 s			50	76
P1047	Control Auxiliary Variable Selection Source for Pump Protection	0 = Without Protection via Control Auxiliary Variable 1 = Control Auxiliary Variable via Analog Input AI1 2 = Control Auxiliary Variable via Analog Input AI2 3 = Control Auxiliary Variable via Analog Input AI3 4 = Control Auxiliary Variable via Analog Input AI4	0			50	77
P1048	Control Auxiliary Variable Sensor Maximum Level (Range)	0 to 32767 [Eng. Un. 2]	1000			50	79
P1049	Value to detect Low Level of Control Auxiliary Variable	0 to 32767 [Eng. Un. 2]	250			50	80
P1050	Control Setpoint in Low Level	-32768 to 32767 [Eng. Un. 1]	160			50	80
P1051	Hysteresis to reactivate the Control Setpoint	0 to 32767 [Eng. Un. 2]	100			50	80



## Quick Parameter Reference, Faults and Alarms



Parameter	Description	Adjustable Range	Factory Setting	User Setting	Properties	Groups	Page
P1052	Execution Mode of the Deragging Function	0 = Not Execute Deragging Function 1 = Executes with Command to Run the Pump 2 = Executes with Command via Digital Input DI2 3 = Executes when the Clogging of Pump is Detected	0			50	82
P1053	Number of Cycles for Deragging	0 to 100	5			50	82
P1054	Speed Reference for Deragging	0 to 18000 rpm	600 rpm			50	83
P1055	Deragging Run Time	0 to 32767 s	10 s			50	83
P1056	Deragging Stop Time	0 to 32767 s	10 s			50	83
P1057	Motor Current to detect Clogging of Pump	0.0 to 3200.0 A	20.0 A			50	83
P1058	Time Delay to detect Clogging of Pump	0 to 32767 s	60 s			50	83
P1059	Number of consecutives Clogging to generate the Fault (F791)	0 to 100	5			50	84
P1060	Control Process Variable Level for Stopping the External Pump	-32768 to 32767 [Eng. Un. 1]	195			50	70
P1061	Control Process Variable Level for Starting the External Pump	-32768 to 32767 [Eng. Un. 1]	185			50	70
P1062	Time Delay for Starting the External Pump	0 to 32767 s	5 s			50	71
P1063	Action Mode of Schedules according to the Day of Week	0 = Disable Weekly Schedule (valid for P1021=0 or P1028=0) 1 = Schedule 1 to 12 from Monday to Sunday 2 = Schedule 1 to 6 from Monday to Friday and Schedule 7 to 12 on Saturday and Sunday 3 = Schedule 1 to 4 from Monday to Friday and Schedule 5 to 8 on Saturday and Schedule 9 to 12 on Sunday	1			50	44
P1064	Hour to Start the Schedule 1	0 to 23 h	4 h			50	45
P1065	Minute to Start the Schedule 1	0 to 59 min	0 min			50	46
P1066	Control Setpoint / Speed Reference of Schedule 1	-32768 to 32767 [Eng. Un. 1] or rpm	200			50	47
P1067	Hour to Start the Schedule 2	0 to 23 h	9 h			50	45
P1068	Minute to Start the Schedule 2	0 to 59 min	0 min			50	46
P1069	Control Setpoint / Speed Reference of Schedule 2	-32768 to 32767 [Eng. Un. 1] or rpm	240			50	47
P1070	Hour to Start the Schedule 3	0 to 24 h	17 h			50	45
P1071	Minute to Start the Schedule 3	0 to 59 min	0 min			50	46
P1072	Control Setpoint / Speed Reference of Schedule 3	-32768 to 32767 [Eng. Un. 1] or rpm	280			50	47
P1073	Hour to Start the Schedule 4	0 to 24 h	22 h			50	45
P1074	Minute to Start the Schedule 4	0 to 59 min	0 min			50	46
P1075	Control Setpoint / Speed Reference of Schedule 4	-32768 to 32767 [Eng. Un. 1] or rpm	140			50	47
P1076	Hour to Start the Schedule 5	0 to 24 h	24 h			50	45
P1077	Minute to Start the Schedule 5	0 to 59 min	0 min			50	46
P1078	Control Setpoint / Speed Reference of Schedule 5	-32768 to 32767 [Eng. Un. 1] or rpm	0			50	47
P1079	Hour to Start the Schedule 6	0 to 24 h	24 h			50	45
P1080	Minute to Start the Schedule 6	0 to 59 min	0 min			50	46
P1081	Control Setpoint / Speed Reference of Schedule 6	-32768 to 32767 [Eng. Un. 1] or rpm	0			50	47
P1082	Hour to Start the Schedule 7	0 to 24 h	24 h			50	45
P1083	Minute to Start the Schedule 7	0 to 59 min	0 min			50	46
P1084	Control Setpoint / Speed Reference of Schedule 7	-32768 to 32767 [Eng. Un. 1] or rpm	0			50	47
P1085	Hour to Start the Schedule 8	0 to 24 h	24 h			50	45
P1086	Minute to Start the Schedule 8	0 to 59 min	0 min			50	46

## Quick Parameter Reference, Faults and Alarms



Parameter	Description	Adjustable Range	Factory Setting	User Setting	Properties	Groups	Page
P1087	Control Setpoint / Speed Reference of Schedule 8	-32768 to 32767 [Eng. Un. 1] or rpm	0			50	47
P1088	Hour to Start the Schedule 9	0 to 24 h	24 h			50	45
P1089	Minute to Start the Schedule 9	0 to 59 min	0 min			50	46
P1090	Control Setpoint / Speed Reference of Schedule 9	-32768 to 32767 [Eng. Un. 1] or rpm	0			50	47
P1091	Hour to Start the Schedule 10	0 to 24 h	24 h			50	45
P1092	Minute to Start the Schedule 10	0 to 59 min	0 min			50	46
P1093	Control Setpoint / Speed Reference of Schedule 10	-32768 to 32767 [Eng. Un. 1] or rpm	0			50	47
P1094	Hour to Start the Schedule 11	0 to 24 h	24 h			50	45
P1095	Minute to Start the Schedule 11	0 to 59 min	0 min			50	46
P1096	Control Setpoint / Speed Reference of Schedule 11	-32768 to 32767 [Eng. Un. 1] or rpm	0			50	47
P1097	Hour to Start the Schedule 12	0 to 24 h	24 h			50	45
P1098	Minute to Start the Schedule 12	0 to 59 min	0 min			50	46
P1099	Control Setpoint / Speed Reference of Schedule 12	-32768 to 32767 [Eng. Un. 1] or rpm	0			50	47

## Quick Parameter Reference, Faults and Alarms



Fault / Alarm	Description	Possible Causes
A750: Sleep Mode Active	It indicates that the Pump Genius is in the sleep mode	Value of the pump motor speed is below the threshold programmed in P1037 during the time programmed in P1038
A752: Pipe Charging	It indicates that the process of pipe charging is being executed	The Run/Stop command was is executed in the CFW-11 inverter with the pipe charging enabled
A756: Sleep Boost Active	It indicates that the sleep boost is in execution	Motor speed was below the value set in P1037 during the time set in P1038, but before going into sleep mode applies a boost in the control setpoint to increase the process variable
A760: DI3 not programmed for PID in Manual / Automatic	It indicates that the parameter of digital input DI3 (P0265) was not programmed to select the PID controller in Manual (0) / Automatic (1)	PID Controller was enabled to have selection Manual / Automatic (P1029 =2) and the digital input DI3 wasn't programmed correctly (P0265≠21)
A770: Low Level of the Control Process Variable	It indicates that the control process variable (P1016) is in low level	The control process variable (P1016) is lower than the value programmed in P1024
F771: Low Level of the Control Process Variable	It indicates that the pump was stopped due to low level of the control process variable	The control process variable (P1016) remained for a time (P1025) at a value lower than the threshold programmed in P1024
A772: High Level of the Control Process Variable	It indicates that the control process variable (P1016) is in high level	The control process variable (P1016) is higher than the value programmed in P1026
F773: High Level of the Control Process Variable	It indicates that the pump was stopped due to high level of the control process variable	The control process variable (P1016) remained for a time (P1027) at a value higher than the threshold programmed in P1026
A774: Low Level of Control Auxiliary Variable	It indicates that the control auxiliary variable (P1017) is in low level and the control setpoint was changed to the value of P1050	The control auxiliary variable (P1017) is lower than the value programmed in P1049
A780: Dry Pump	It indicates that the dry pump condition was detected	Value of the pump motor speed is above of the threshold programmed in P1043 and motor torque is below the threshold programmed in P1044
F781: Dry Pump	It indicates that the pump was stopped due to dry pump protection	During a time (P1045) the value of the pump motor speed remains above of the threshold programmed in P1043 and motor torque remains below the threshold programmed in P1044
A782: External Sensor Protection	It indicates that protection via external sensor (DI6) is actuated	Pump in operation and digital input DI6 is at logic level "0"
F783: External Sensor Protection	It indicates that the pump was stopped due to protection via external sensor (DI6)	Pump in operation and digital input DI6 remained at logic level "0" for a time (P1046)
A790: Clogging Detected	It indicates that the clogging of pump was detected due the high current in the pump motor	Deragging was configured to execute when clogging is detected (P1052=3) and the motor current was greater than the motor current to detect the pump clogging (P1057) during a time to detect the pump clogging (P1058).
F791: Excess of Clogging	It indicates that the pump was stopped due a excess number of clogging detected	Deragging was configured to execute when clogging is detected (P1052=3) and the number of clogging detected was equal to the value defined as limit to generate a fault by consecutives clogging (P1059)
A792: Deragging Configuration Error	It indicates that the deragging couldn't be executed due the forward/reverse selection in REMOTE mode (P0226) not be configured to be via SoftPLC	Speed reference in REMOTE mode was programmed to SoftPLC (P0222=12), the CFW-11 frequency inverter is on REMOTE mode, but the forward/reverse selection in REMOTE mode wasn't programmed to SoftPLC (P0226=12 or 13)
A794: Deragging is in Execution	It indicates that the deragging function is in execution	The deragging function is enabled (P1052≠0) and in execution
A796: Deragging not Executed	It indicates that the deragging couldn't be executed due to the CFW-11 inverter be in LOCAL mode	The deragging function is enabled (P1052≠0), but couldn't be executed due to the CFW-11 inverter be operating in LOCAL mode
F799: Incompatible Software Version	It Indicates that the software version of the CFW-11 inverter is not compatible with the software version required to use the Pump Genius Simplex application	The value of the P0023 parameter that indicates the software version of the CFW-11 inverter is less than 5.30 or greater than 5.39

# 1 INTRODUCTION TO THE PUMP GENIUS SIMPLEX APPLICATION

The Pump Genius Simplex application developed for the CFW-11 inverter SoftPLC function provides the user with flexibility in the operation and configuration. Tools, already developed for the WLP programming software, are being used together with configuration wizards and monitoring dialogs boxes.

## 1.1 PUMPS

Pumps are hydraulic operating machines that transfer energy to the fluid for the purpose of transporting it from one point to another. They receive energy from a motor source and transfer part of it to the fluid in the form of pressure energy, kinetic energy, or both, i.e., increase the fluid's pressure or speed, or both quantities.

Commonly used ways to drive pumps are:

- Electric motors;
- Internal combustion motors;
- Turbines.

Pumps can be classified into two wide categories:

- Centrifugal pumps or turbo pumps;
- Volumetric pumps or positive displacement pumps.

### 1.1.1 Centrifugal Pumps

The operating based on the principle of transferring kinetic energy to the fluid to be pumped; this kinetic energy is transformed into potential energy (pressure). The rotational movement of a rotor inserted into a casing is the functional part responsible for this transformation.

Depending on the types and shapes of rotors, centrifugal pumps can be classified as follows:

- **Radial or pure**, when the direction of the pumped fluid is perpendicular to the rotating axle;
- **Mixed flow or semi-axial**, when the direction of the pumped fluid is inclined in relation to the rotating axle;
- **Axial flow**, when the direction of the pumped fluid is parallel in relation to the rotating axle.

### 1.1.2 Positive Displacement Pumps

The operating principle of this type of pump is based on the direct transfer of mechanical work (of a motor shaft rotation against a load torque) into potential energy (pressure energy). This transfer is obtained by the movement of a mechanical apparatus of the pump (piston, diaphragm, gears, screws, etc.), which forces the fluid to execute the same movement.

The liquid cyclical fills and then is ejected from a given volume of space inside the pump, a process which is responsible for the name "Volumetric Pump".

Variations of these mechanical apparatuses permit the classification of volumetric or positive displacement pumps:

- **Piston or alternative pumps**, when the apparatus which produces the movement of the fluid is a piston which moves in alternating directions and expels the pumped fluid;
- **Rotary pumps**, when the apparatus which produces the movement of the fluid is driven by rotational movement, like a screw, gear, flukes, lobes, etc.

## 1.2 GENERAL CHARACTERISTICS OF THE PUMP GENIUS SIMPLEX APPLICATION

The main characteristic of the Pump Genius Simplex application developed for the CFW-11 inverter SoftPLC function is the control of one pump using for this a frequency inverter that will control your speed as required by the user demand.

Each is notable for the following characteristics:

- Control of only one pump driven by CFW-11 inverter;
- Acceleration and deceleration ramps for the pump driven by inverter;
- Maximum and minimum speed limits for the pump driven by inverter;
- Selection of the control setpoint via analog input, CFW-11 HMI, logical combination of the two digital inputs DI4 and DI5 (maximum of 4 setpoints) or weekly schedule based in real time clock (RTC) of the CFW-11 inverter;
- Programming of two to twelve values of control setpoint or speed reference (PID controller disabled) as the time and day of week defined;
- Selection of the control process variable via analog input or the difference between analog input AI1 and AI2 (AI1 – AI2); allows also not have the control process variable so disabling the PID controller;
- Selection of the engineering unit and range of the control process variable sensor via CFW-11 parameters;
- Gain, offset and filter adjustments for the control signals via analog inputs;
- PID controller gains setting of the pumping control via HMI parameters;
- Control action of the PID controller configured for direct mode or reverse mode, or can be disabled;
- Selection of operation mode of the PID controller in Manual or Automatic, and may be selecting via digital input DI3 or via parameter;
- Enable or not of the sleep mode with the PID controller enabled;
- Enable or not of the sleep boost before to going into sleep mode;
- Wake up mode or start level mode for starting the pump with the PID controller enabled;
- Initiate the pumping with pipe charging through the pump driven by inverter;
- Adjustment of the motor current limitation during the pipe charging process;
- Enable or not the use of an external pump for jockey pump function (control the pumping when the demand is minimal) via digital input DI1 and command via digital output DO1;
- Low level protection for the control process variable (pipe breaking);
- High level protection for the control process variable (pipe obstruction);
- Indication of the low or high level alarm protection for the control process variable via digital output DO3;
- Indication of the real time clock (RTC) with error via digital output DO2
- Dry pump protection through evaluation of motor torque and pump speed;
- Pump protection via external sensor in the digital input DI6;
- Selection of an analog input as a control auxiliary variable for pump protection;
- Pump cavitation protection via low level limitation for the control auxiliary variable;
- Detection clogging of a pump driven by the inverter via high current in the motor;
- Execution of the deragging of the pump via a command in the digital input DI2, or a command to start the pump or when the clogging of pump is detected;
- Possibility to enable the pump driven by the frequency inverter via HMI (local mode)
- Possibility of implementation or modification of the application by the user through the WLP software.

## 2 PUMP GENIUS SIMPLEX CONFIGURATION

In the Pump Genius Simplex application developed for the CFW-11 SoftPLC function several possibilities of use or configuration were implemented: have only one pump, associated on external pump, protect the pump using an analog variable or a digital sensor, enable the PID controller in automatic or manual via digital input DI3, enable the functionality for deragging the pump, define that the control setpoint or the speed reference acts according to weekly schedule defined by the user, etc.



**NOTE!**

The Pump Genius Simplex application only works on CFW-11 inverter with **especial firmware version Ve.5.3x**. So upgrading the CFW-11 inverter firmware to the working of this application is required.

### 2.1 CONTROL SETPOINT VIA HMI

The user can configure the Pump Genius Simplex application to having one pump and the control setpoint adjusted via HMI of the CFW-11 inverter, which is the simplest way configuration. It basically comprises:

- 01 CFW-11 inverter (D1);
- 01 Electric motor and pump (P1);
- 01 Sensor with analog output signal for measurement of the control process variable (A1);
- Command for Run/Stop (S1);
- Status light for inverter fault (H1);
- Status light for motor running (H2);
- Status light for low or high level protection for the control process variable (H3).

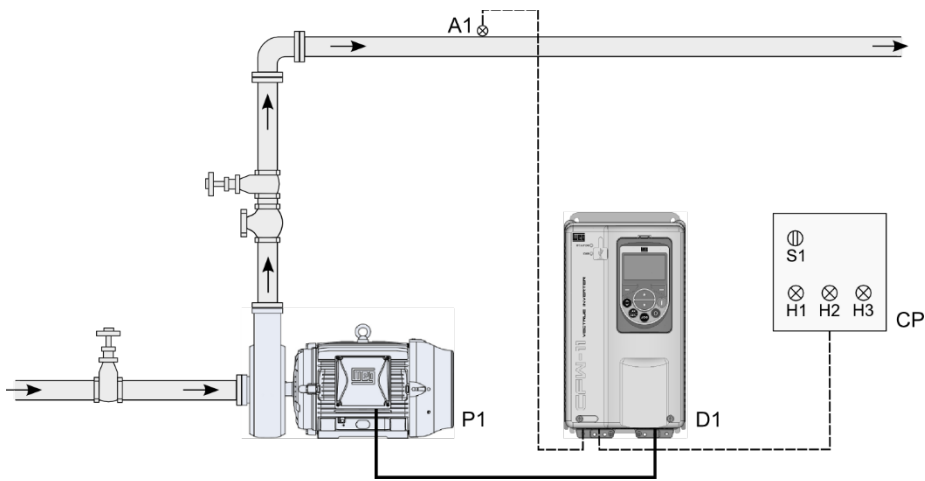

Figure 2.1 – Pump Genius Simplex application and control setpoint via HMI



**NOTE!**

Using the **Pump Genius Simplex** configuration wizard to configure the pump driven by CFW-11 inverter with control setpoint via HMI. See chapter 5 for more details on the configuration wizard.



**NOTE!**

The indicating lights H1, H2 and H3 are not necessary for the operation of the Pump Genius with control setpoint via HMI. They only indicate the condition of the pump operation at the command panel (CP).

## Pump Genius Simplex Configuration

The figure 2.2 presents the control connections (analog inputs/outputs, digital inputs/outputs) that must be made at the CC11 control board terminal strip XC1 of the CFW-11 inverter to have the control setpoint adjusted via HMI.

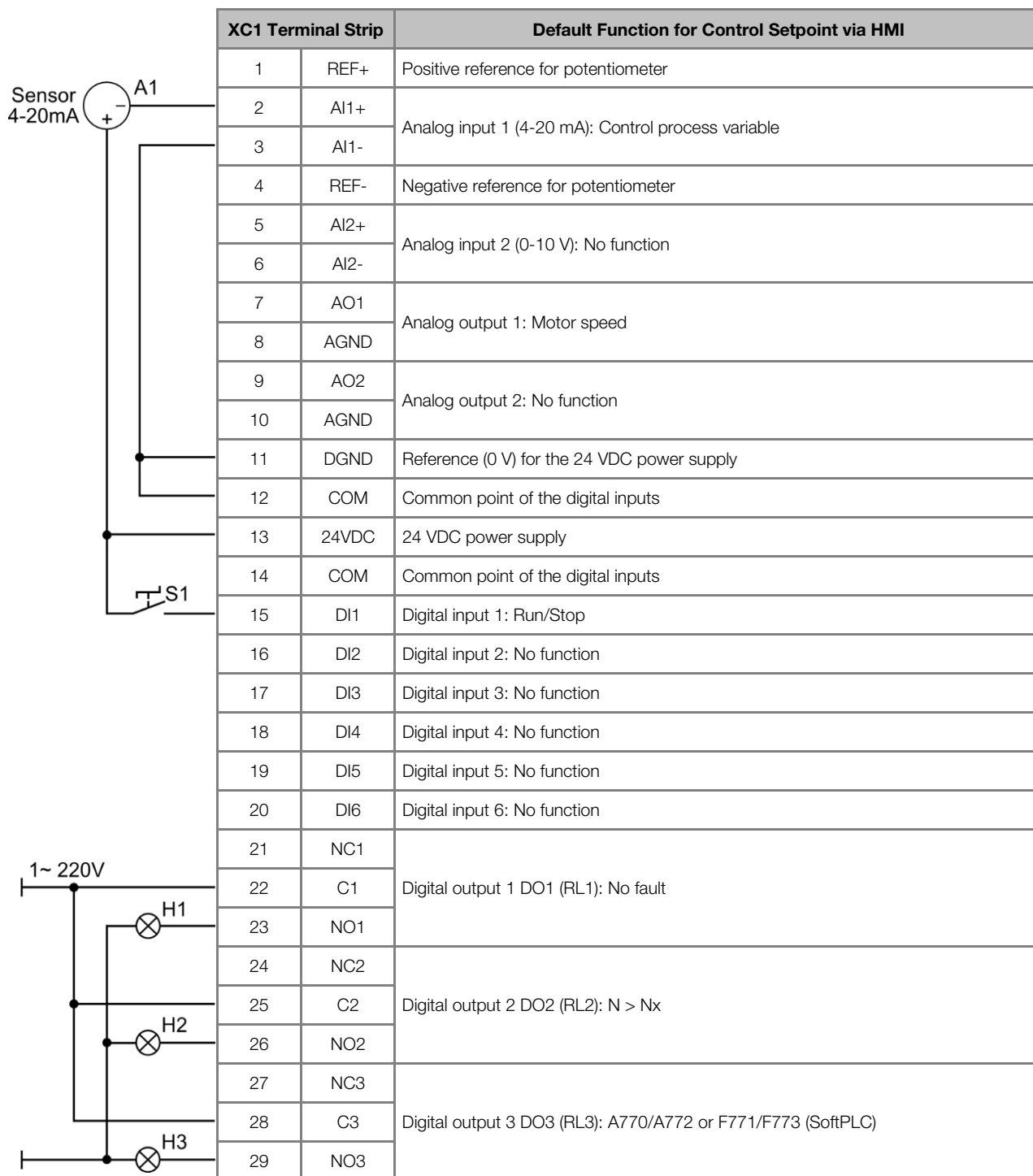

Figure 2.2 – Terminal strip XC1 for control setpoint via HMI



**NOTE!**

Refer to the CFW-11 inverter manual for more information on the connections.

## Pump Genius Simplex Configuration

### 2.2 CONTROL SETPOINT VIA ANALOG INPUT

The user can configure the Pump Genius Simplex application to having one pump and the control setpoint adjusted via one analog input of the CFW-11 inverter, which basically comprises:

- 01 CFW-11 inverter (D1);
- 01 Electric motor and pump (P1);
- 01 Sensor with analog output signal for measurement of the control process variable (A1);
- 01 Potentiometer for adjusting the control setpoint via input analog (R1);
- Command for Run/Stop (S1);
- Status light for inverter fault (H1);
- Status light for motor running (H2);
- Status light for low or high level protection for the control process variable (H3).

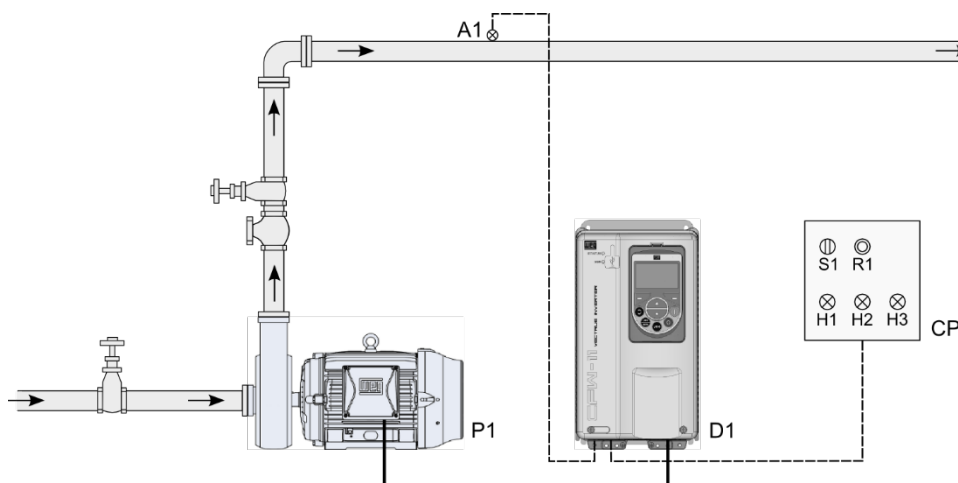

*Figure 2.3 – Pump Genius Simplex application and control setpoint via analog input*



#### NOTE!

Using the **Pump Genius Simplex** configuration wizard to configure the pump driven by CFW-11 inverter with control setpoint via analog input. See chapter 5 for more details on the configuration wizard.



#### NOTE!

The indicating lights H1, H2 and H3 are not necessary for the operation of the Pump Genius with control setpoint via analog input. They only indicate the condition of the pump operation at the command panel (CP).



## Pump Genius Simplex Configuration

The figure 2.4 presents the control connections (analog inputs/outputs, digital inputs/outputs) that must be made at the XC1 control board terminal strip of the CFW-11 inverter to have the control setpoint via analog input.

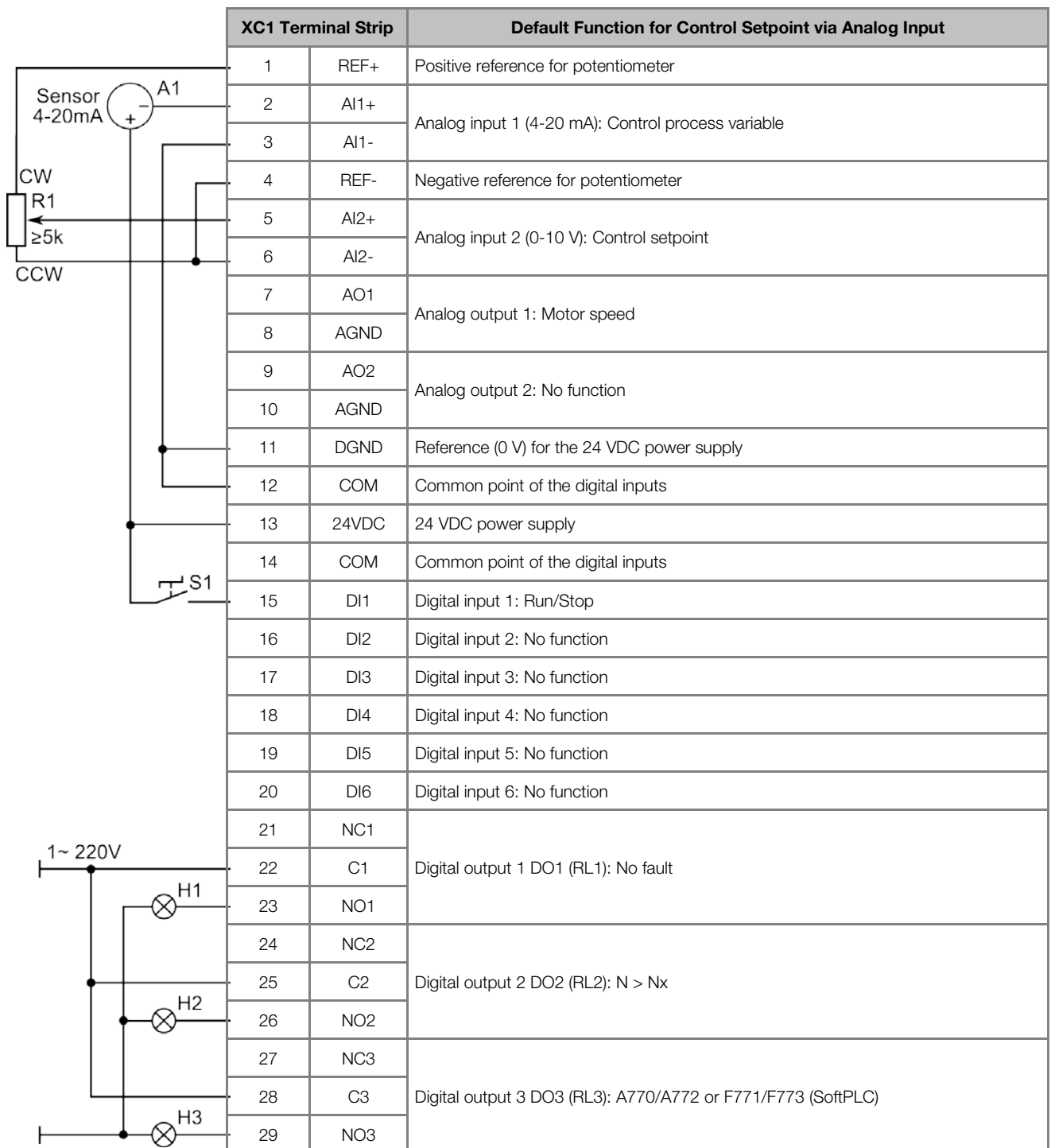

Figure 2.4 – Terminal strip XC1 for control setpoint via analog input



**NOTE!**

Refer to the CFW-11 inverter manual for more information on the connections.

## Pump Genius Simplex Configuration

### 2.3 CONTROL SETPOINT VIA LOGICAL COMBINATION OF THE DIGITAL INPUTS DI4 AND DI5

The user can configure the Pump Genius Simplex application to having one pump and the control setpoint adjusted via logical combination of digital inputs DI4 and DI5 which basically comprises:

- 01 CFW-11 inverter (D1);
- 01 Electric motor and pump (P1);
- 01 Sensor with analog output signal for measurement of the control process variable (A1);
- Command for Run/Stop (S1);
- Switch of "n" positions for selection of the control setpoint (S4);
- Status light for inverter fault (H1);
- Status light for motor running (H2);
- Status light for low or high level protection for the control process variable (H3).

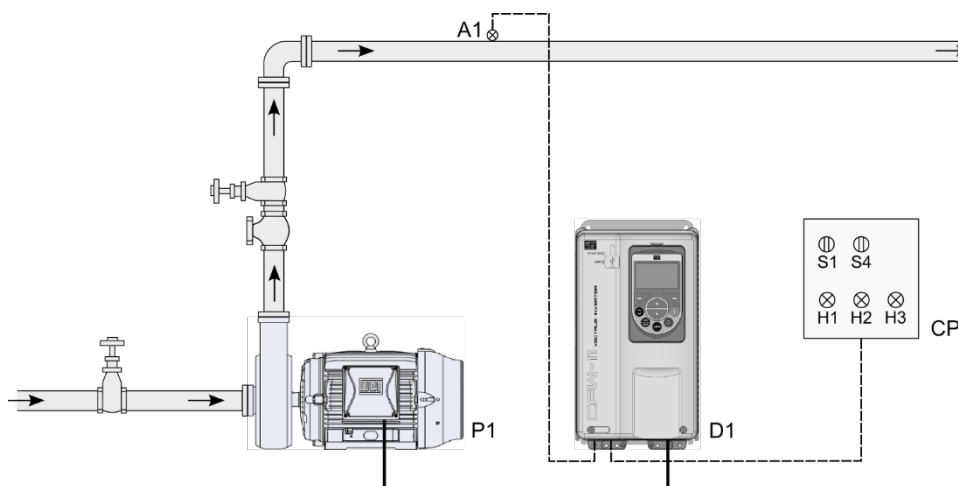

*Figure 2.5 – Pump Genius Simplex application and control setpoint via logical combination of the digital inputs DI4 and DI5*



**NOTE!**

Using the **Pump Genius Simplex** configuration wizard to configure the pump driven by CFW-11 inverter with control setpoint via logical combination of the digital inputs DI4 and DI5. See chapter 5 for more details on the configuration wizard.



**NOTE!**

The indicating lights H1, H2 and H3 are not necessary for the operation of the Pump Genius with control setpoint via logical combination of the digital inputs DI4 and DI5. They only indicate the condition of the pump operation at the command panel (CP).

## Pump Genius Simplex Configuration

The figure 2.6 presents the control connections (analog inputs/outputs, digital inputs/outputs) that must be made at the CC11 control board terminal strip XC1 of the CFW-11 inverter to have the control setpoint via logical combination of digital inputs DI4 and DI5.

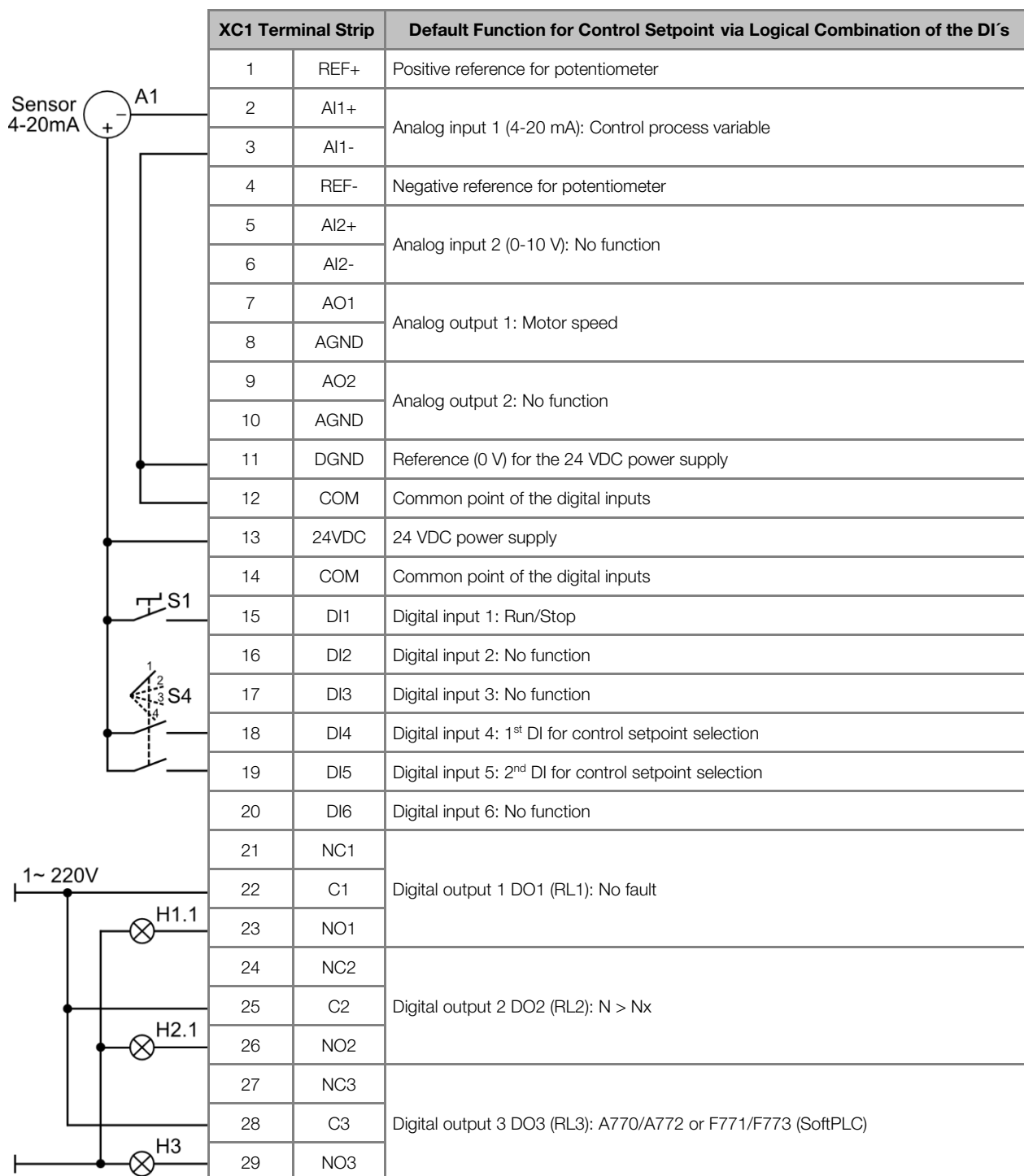

Figure 2.6 – Terminal strip XC1 for control setpoint via logical combination of the digital inputs DI4 and DI5



**NOTE!**

Refer to the CFW-11 inverter manual for more information on the connections.

## Pump Genius Simplex Configuration

### 2.4 CONTROL SETPOINT ACCORDING TO WEEKLY SCHEDULE

The user can configure the Pump Genius Simplex application to having one pump and the two to twelve values of control setpoint selected according to weekly schedule defined witch basically comprises:

- 01 CFW-11 inverter (D1);
- 01 Electric motor and pump (P1);
- 01 Sensor with analog output signal for measurement of the control process variable (A1);
- Command for Run/Stop (S1);
- Status light for inverter fault (H1);
- Status light for motor running (H2);
- Status light for low or high level protection for the control process variable (H3).

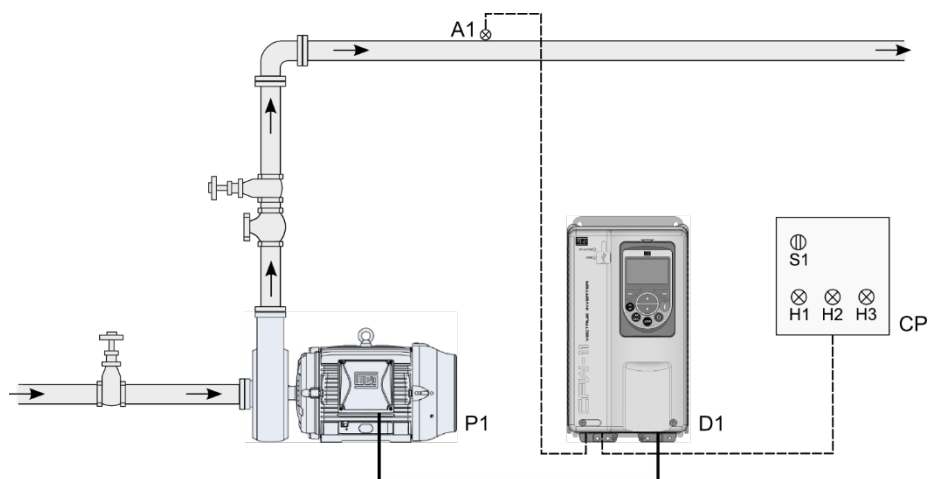

*Figure 2.7– Pump Genius Simplex application and control setpoint according to weekly schedule*



**NOTE!**

Using the **Pump Genius Simplex** configuration wizard to configure the pump driven by CFW-11 inverter with control setpoint according to weekly schedule. See chapter 5 for more details on the configuration wizard.



**NOTE!**

The indicating lights H1, H2 and H3 are not necessary for the operation of the Pump Genius with control setpoint according to weekly schedule. They only indicate the condition of the pump operation at the command panel (CP).

## Pump Genius Simplex Configuration

The figure 2.8 presents the control connections (analog inputs/outputs, digital inputs/outputs) that must be made at the CC11 control board terminal strip XC1 of the CFW-11 inverter to have the control setpoint according to weekly schedule.

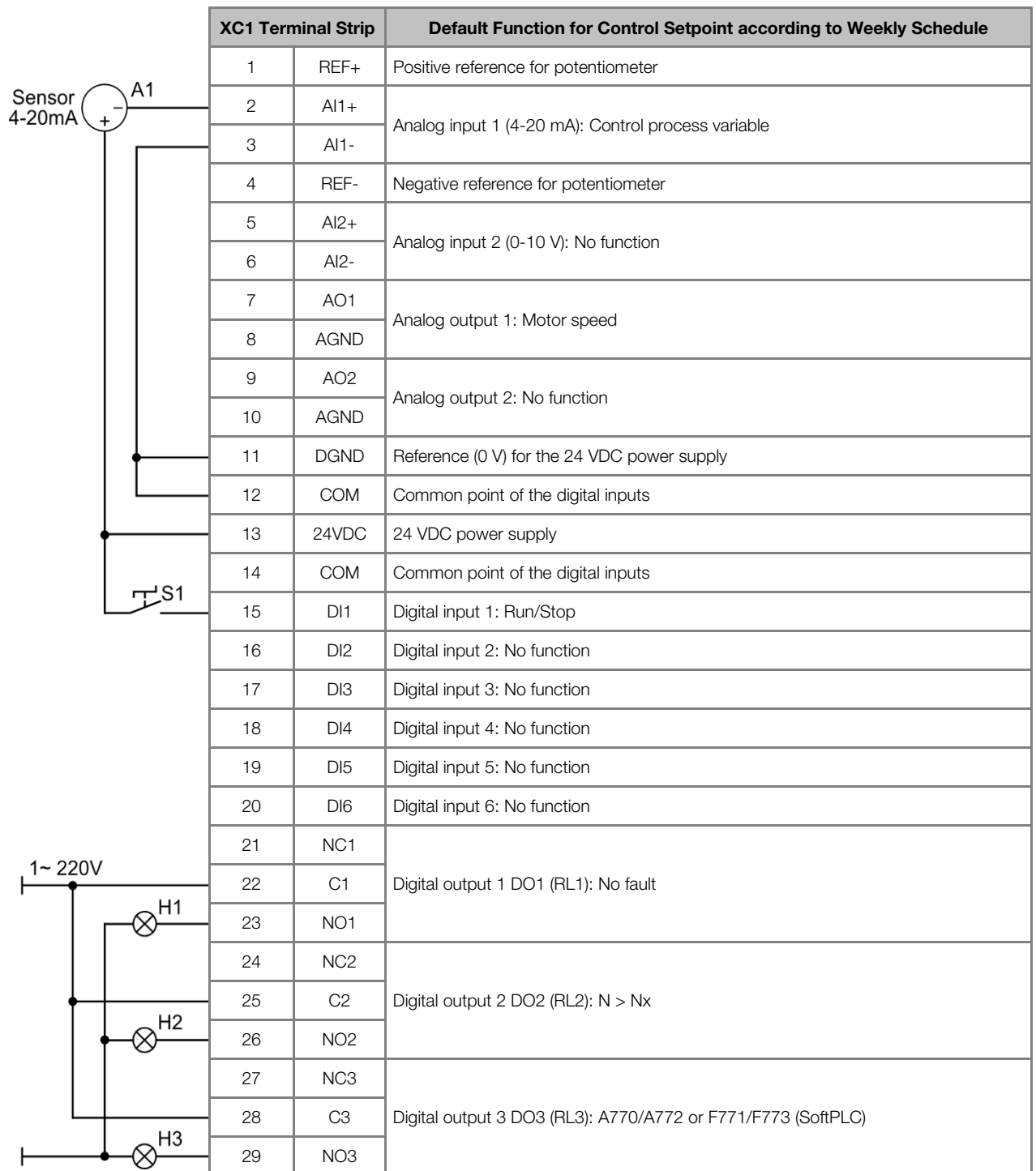

Figure 2.8 – Terminal strip XC1 for control setpoint according to weekly schedule



**NOTE!**

Refer to the CFW-11 inverter manual for more information on the connections.

## Pump Genius Simplex Configuration

### 2.5 SELECTION OF PID CONTROLLER IN MANUAL OR AUTOMATIC VIA DIGITAL INPUT DI3

The user can configure the Pump Genius Simplex application to having one pump and the selection of PID controller operation mode in manual or automatic via digital input DI3 which basically comprises:

- 01 CFW-11 inverter (D1);
- 01 Electric motor and pump (B1);
- 01 Sensor with analog output signal for measurement of the control process variable (A1);
- Command for Run/Stop (S1);
- Manual (0) / Automatic (1) commutation switch to select the operation mode of the PID controller (S3);
- Status light for inverter fault (H1);
- Status light for motor running (H2);
- Status light for low or high level protection for the control process variable (H3).

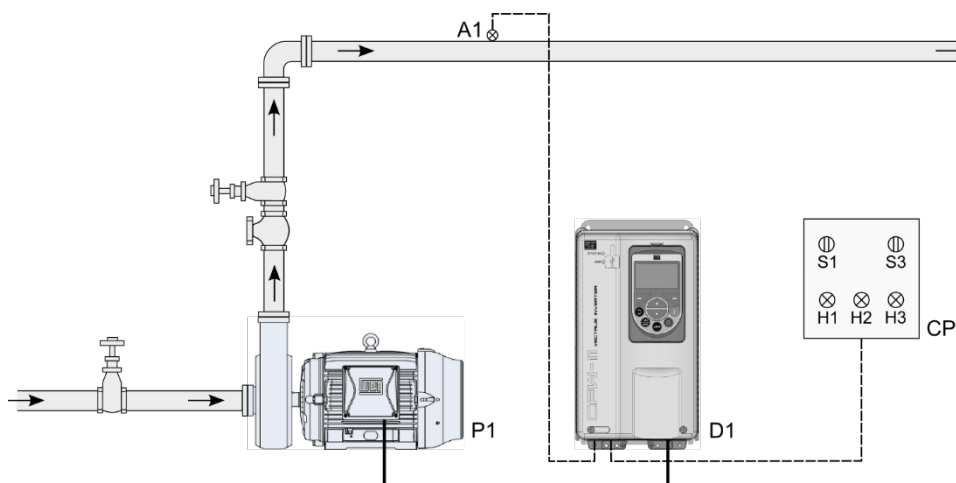

*Figure 2.9 – Pump Genius Simplex application and selection of PID controller in manual or automatic via digital input DI3*



**NOTE!**

Using the **Pump Genius Simplex** configuration wizard to configure the pump driven by CFW-11 inverter with selection of PID controller in manual or automatic via digital input DI3. See chapter 5 for more details on the configuration wizard.



**NOTE!**

The indicating lights H1, H2 and H3 are not necessary for the operation of the Pump Genius with selection of PID controller in manual or automatic via digital input DI3. They only indicate the condition of the pump operation at the command panel (CP).

## Pump Genius Simplex Configuration

The figure 2.10 presents the control connections (analog inputs/outputs, digital inputs/outputs) that must be made at the CC11 control board terminal strip XC1 of the CFW-11 inverter to have the selection of PID controller in manual or automatic via digital input DI3.

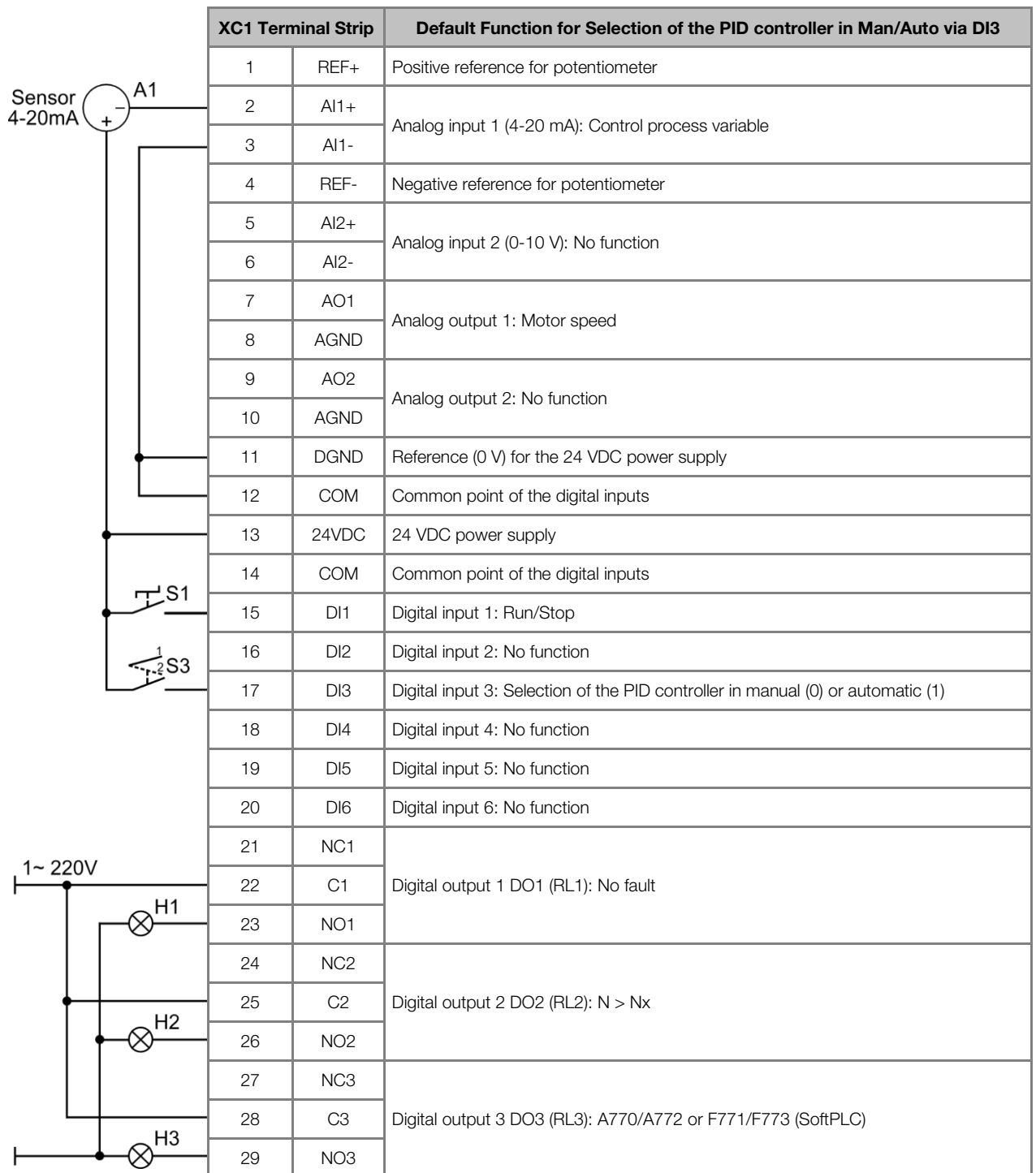

Figure 2.10 – Terminal strip XC1 for selection of PID controller in manual or automatic via digital input DI3



**NOTE!**

Refer to the CFW-11 inverter manual for more information on the connections.

## Pump Genius Simplex Configuration

### 2.6 EXTERNAL PUMP FOR JOCKEY PUMP FUNCTION

The user can configure the Pump Genius Simplex application to having one pump and be able to command another pump (external) of lesser capacity for jockey pump function, i.e., control the pumping when the demand is minimal which basically comprises:

- 01 CFW-11 inverter (D1);
- 01 Electric motor and pump (P1);
- 01 Electric motor and external pump (EP);
- 01 Sensor with analog output signal for measurement of the control process variable (A1);
- Command to enable the use of the external pump (S1);
- Command for Run/Stop (S2);
- Status light for external pump running (H1);
- Status light for inverter fault (H2);
- Status light for motor running (H3).

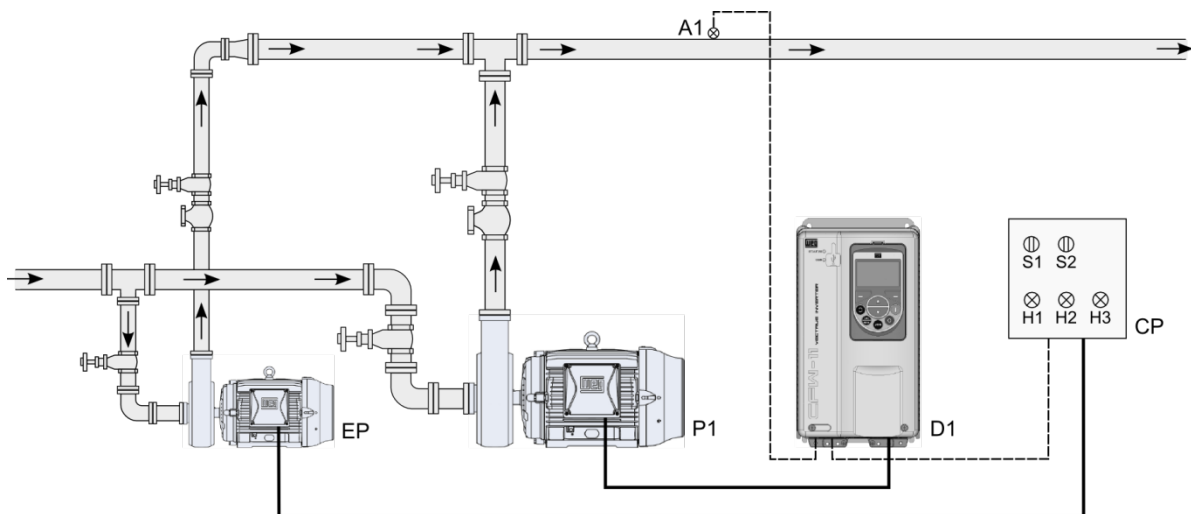

*Figure 2.11 – Pump Genius Simplex application and an external pump for jockey pump function*



**NOTE!**

Using the **Pump Genius Simplex** configuration wizard to configure the pump driven by CFW-11 inverter with an external pump for jockey pump function. See chapter 5 for more details on the configuration wizard.



**NOTE!**

The external pump can be driven by a contactor (direct on line or star delta start), a soft-starter, a smart relay, etc. The indicating lights H1, H2 and H3 are not necessary for the operation of the Pump Genius with an external pump for jockey pump. They only indicate the condition of the pump operation at the command panel (CP).



## Pump Genius Simplex Configuration

The figure 2.12 presents the control connections (analog inputs/outputs, digital inputs/outputs) that must be made at the CC11 control board terminal strip XC1 of the CFW-11 inverter to have an external pump for jockey pump function.

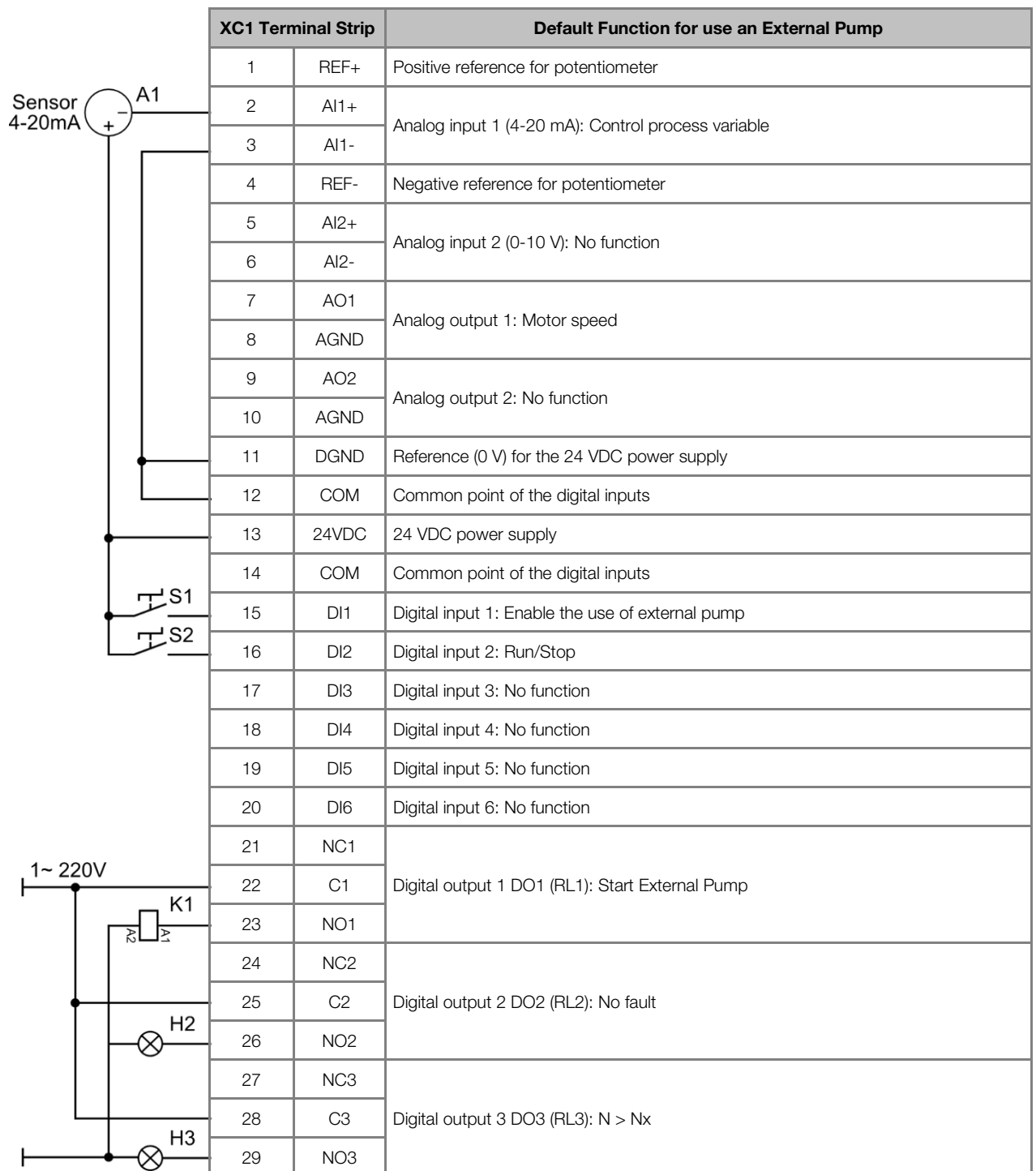

Figure 2.12 – Terminal strip XC1 for use an external pump for jockey pump function



**NOTE!**

Refer to the CFW-11 inverter manual for more information on the connections.

## Pump Genius Simplex Configuration

### 2.7 PUMP PROTECTION VIA EXTERNAL SENSOR IN THE DIGITAL INPUT DI6

The user can configure the Pump Genius Simplex application to having one pump and protect it via an external sensor installed in the digital input DI6 which basically comprises:

- 01 CFW-11 inverter (D1);
- 01 Electric motor and pump (P1);
- 01 Sensor with analog output signal for measurement of the control process variable (A1);
- 01 Sensor with “NO” contact for pump protection (S6);
- Command for Run/Stop (S1);
- Status light for inverter fault (H1);
- Status light for motor running (H2);
- Status light for low or high level protection for the control process variable (H3).

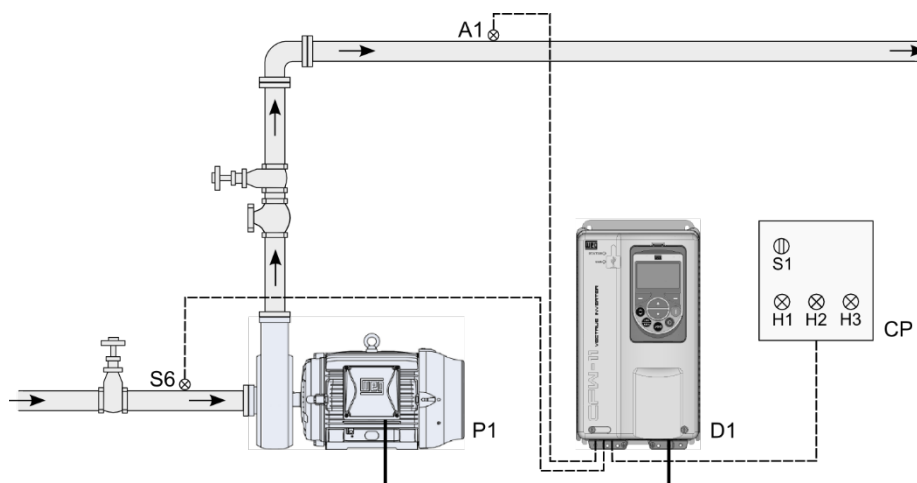

*Figure 2.13 – Pump Genius Simplex application and pump protection via external sensor in the digital input DI6*



#### NOTE!

Using the **Pump Genius Simplex** configuration wizard to configure the pump driven by CFW-11 inverter and pump protection with an external sensor via digital input DI6. See chapter 5 for more details on the configuration wizard.



#### NOTE!

The indicating lights H1, H2 and H3 are not necessary for the operation of the Pump Genius and pump protection with an external sensor via digital input DI6. They only indicate the condition of the pump operation at the command panel (CP).

## Pump Genius Simplex Configuration

The figure 2.14 presents the control connections (analog inputs/outputs, digital inputs/outputs) that must be made at the CC11 control board terminal strip XC1 of the CFW-11 inverter to have the pump protection via external sensor in the digital input DI6.

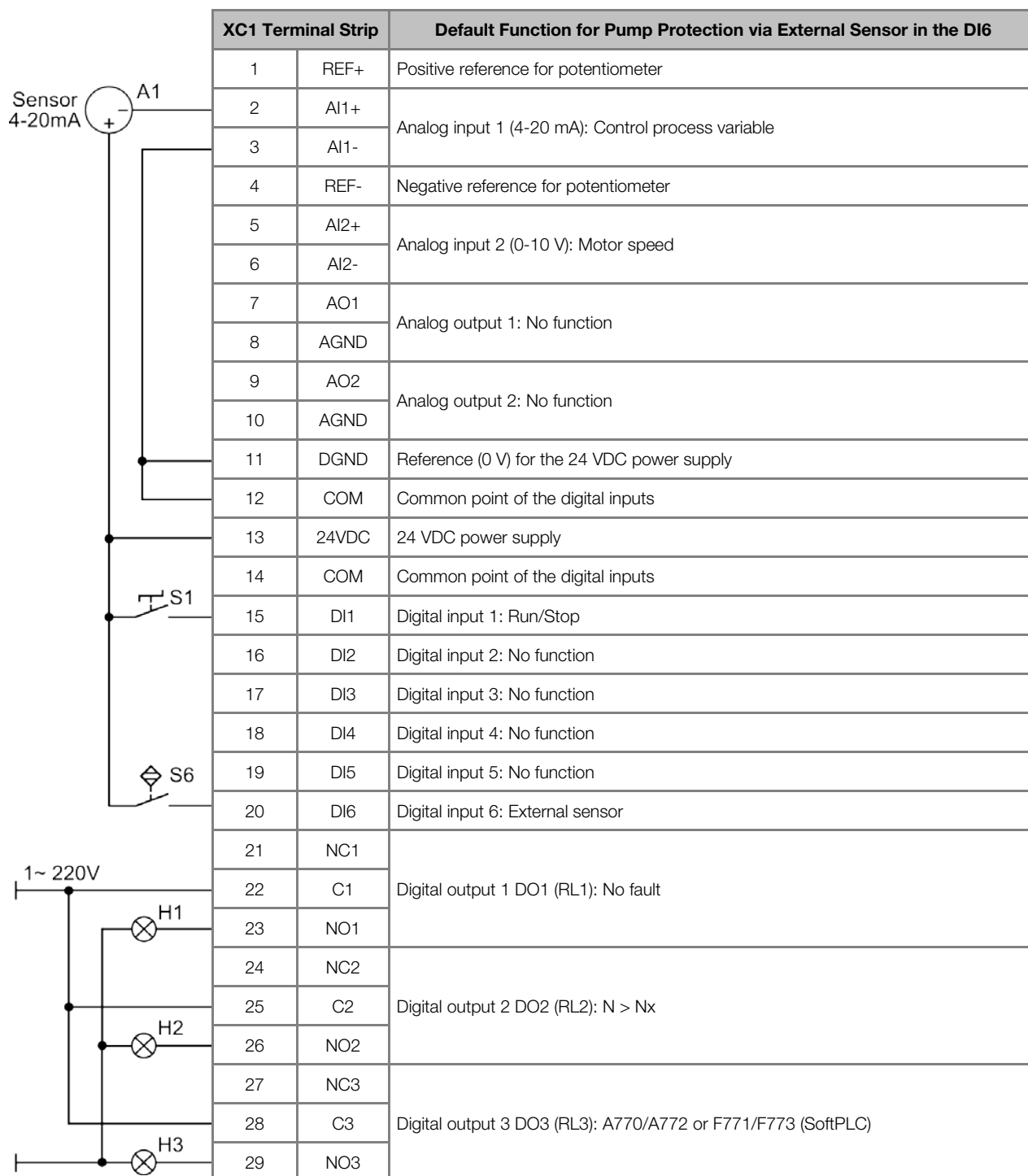

Figure 2.14 – Terminal strip XC1 for pump protection via external sensor in the digital input DI6



**NOTE!**

Refer to the CFW-11 inverter manual for more information on the connections.

## Pump Genius Simplex Configuration

### 2.8 PUMP PROTECTION VIA CONTROL AUXILIARY VARIABLE

The user can configure the Pump Genius Simplex application to having one pump and protect it via a sensor with analog output signal for measure the control auxiliary variable via an analog input which basically comprises:

- 01 CFW-11 inverter (D1);
- 01 Electric motor and pump (P1);
- 01 Sensor with analog output signal for measurement of the control process variable (A1);
- 01 Sensor with analog output signal for measurement of the control auxiliary variable (A2);
- Command for Run/Stop (S1);
- Status light for inverter fault (H1);
- Status light for motor running (H2);
- Status light for low or high level protection for the control process variable (H3).

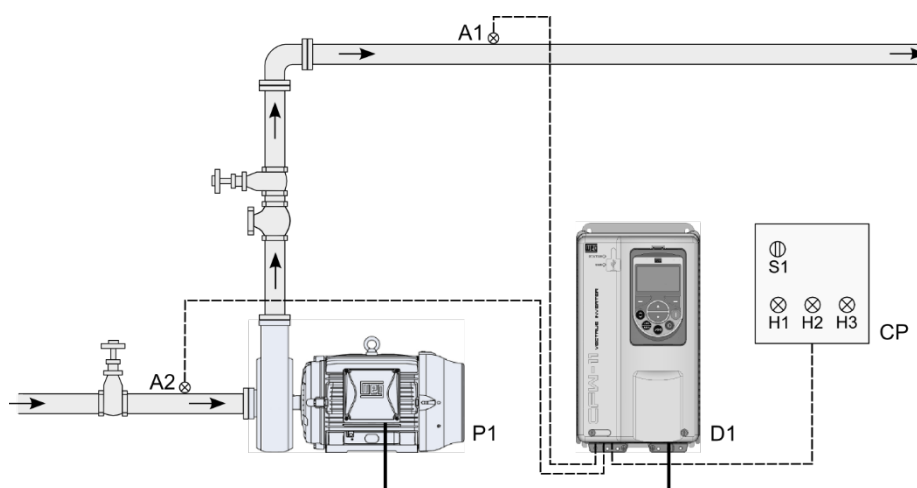

*Figure 2.15 – Pump Genius Simplex application and pump protection via control auxiliary variable read by analog input*



#### NOTE!

Using the **Pump Genius Simplex** configuration wizard to configure the pump driven by CFW-11 inverter and pump protection via control auxiliary variable read by analog input. See chapter 5 for more details on the configuration wizard.



#### NOTE!

The indicating lights H1, H2 and H3 are not necessary for the operation of the Pump Genius and pump protection via control auxiliary variable read by analog input. They only indicate the condition of the pump operation at the command panel (CP).

## Pump Genius Simplex Configuration

The figure 2.16 presents the control connections (analog inputs/outputs, digital inputs/outputs) that must be made at the CC11 control board terminal strip XC1 of the CFW-11 inverter for pump protection via control auxiliary variable read by analog input.

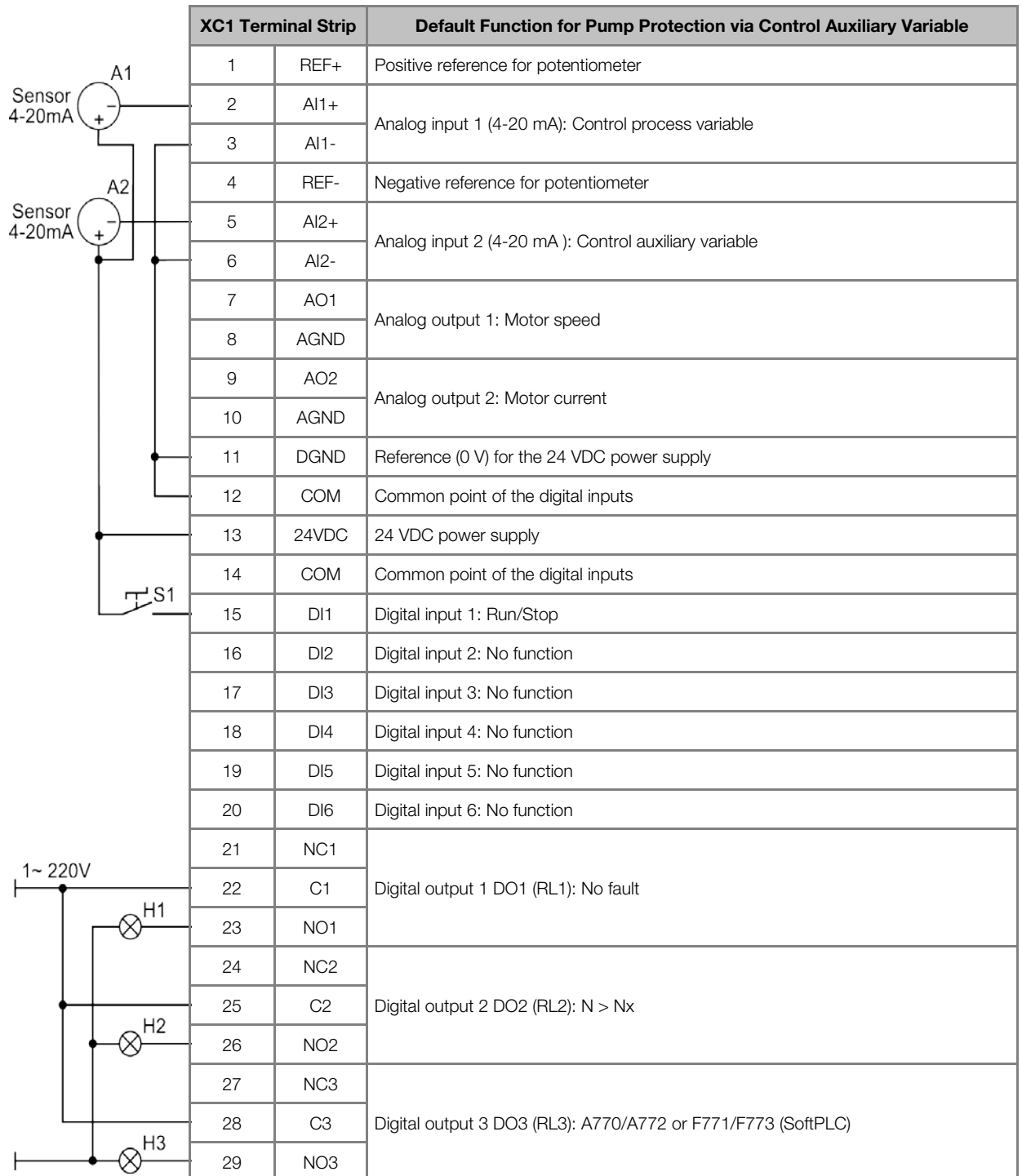

Figure 2.16 – Terminal strip XC1 for pump protection via control auxiliary variable read by analog input



**NOTE!**

Refer to the CFW-11 inverter manual for more information on the connections.

## Pump Genius Simplex Configuration

### 2.9 DERAGGING FUNCTION WITH COMMAND VIA DIGITAL INPUT DI2

The user can configure the Pump Genius Simplex application to having one pump and execute the deragging function through a command via digital input DI2 which basically comprises:

- 01 CFW-11 inverter (D1);
- 01 Electric motor and pump (P1);
- 01 Sensor with analog output signal for measurement of the control process variable (A1);
- Command for Run/Stop (S1);
- Command to execute the deragging function (S2);
- Status light for inverter fault (H1);
- Status light for motor running (H2);
- Status light for low or high level protection for the control process variable (H3).

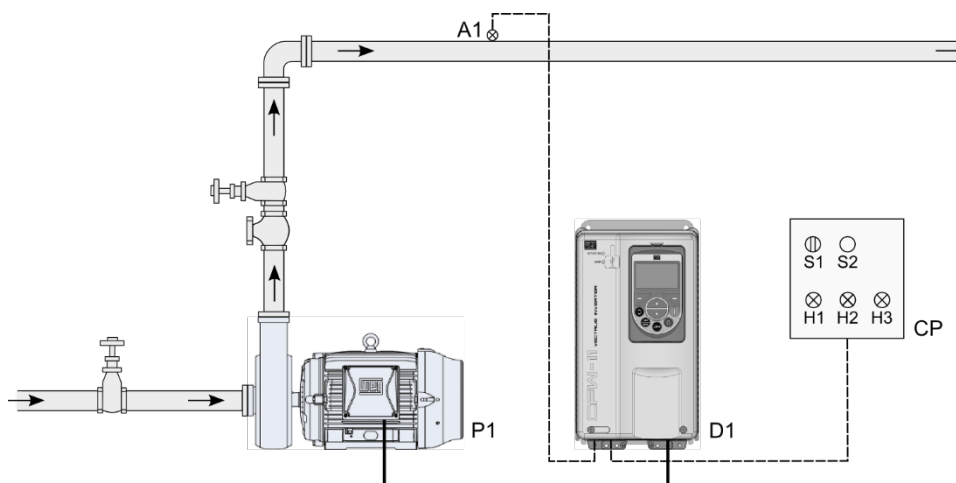

*Figure 2.17 – Pump Genius Simplex application and deragging function with command via digital input DI2*



**NOTE!**

Using the **Pump Genius Simplex** configuration wizard to configure the pump driven by CFW-11 inverter and the deragging function with command via digital input DI2. See chapter 5 for more details on the configuration wizard.



**NOTE!**

The indicating lights H1, H2 and H3 are not necessary for the operation of the Pump Genius and the deragging function with command via digital input DI2. They only indicate the condition of the pump operation at the command panel (CP).

## Pump Genius Simplex Configuration

The figure 2.18 presents the control connections (analog inputs/outputs, digital inputs/outputs) that must be made at the CC11 control board terminal strip XC1 of the CFW-11 inverter to have the deragging function with command via digital input DI2.

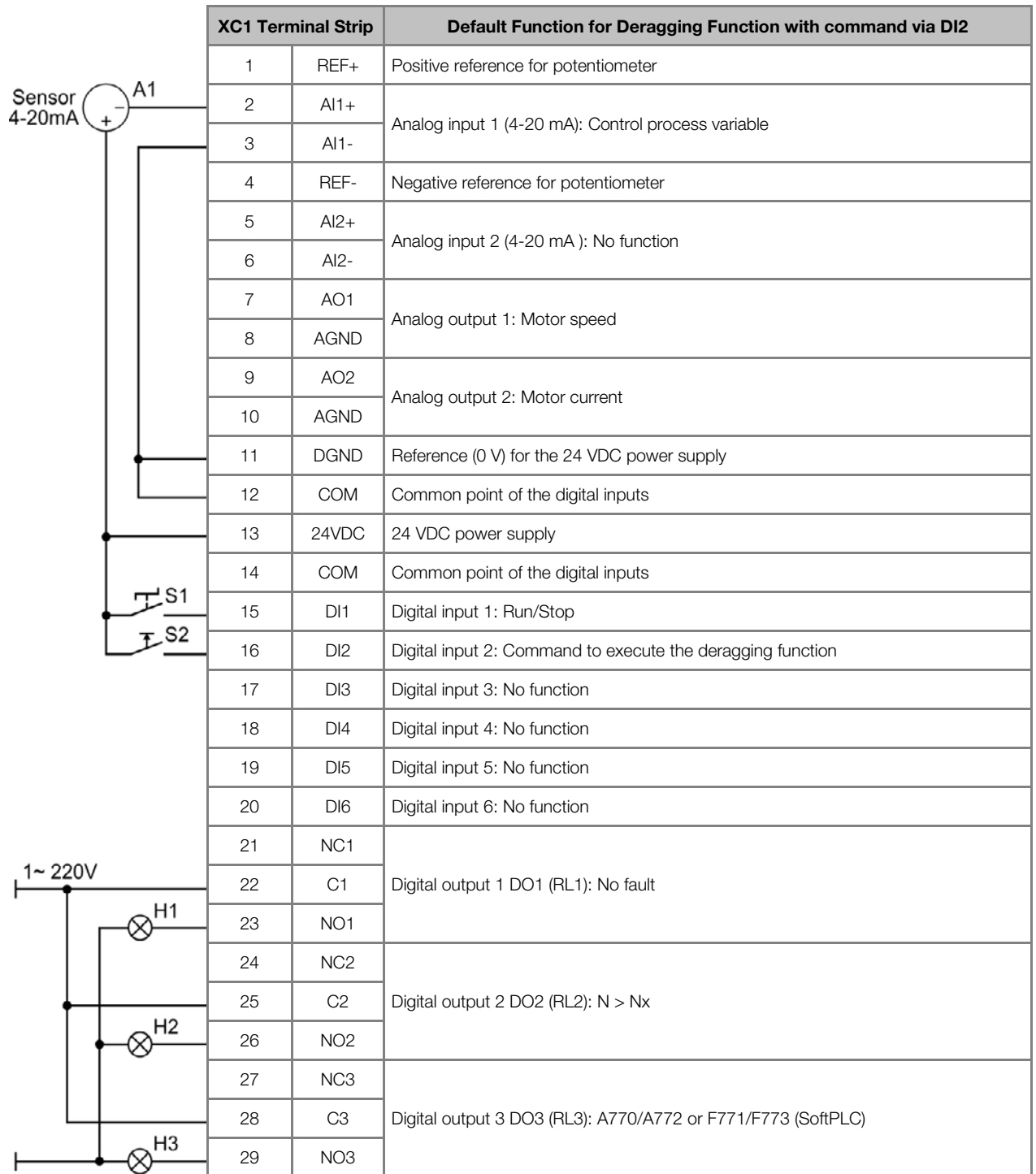

Figure 2.18 – Terminal strip XC1 for deragging function with command via digital input DI2



**NOTE!**

Refer to the CFW-11 inverter manual for more information on the connections.

### 3 PARAMETERS DESCRIPTION

The CFW-11 inverter parameters (P0000 to P0999) and the SoftPLC function parameters (P1000 to P1099) for the Pump Genius Simplex application will be presented next.



**NOTE!**

The Pump Genius Simplex application only works on CFW-11 inverter with **especial firmware version Ve.5.3x**. So upgrading the CFW-11 inverter firmware to the working of this application is required.



**NOTE!**

The adjustable range of the CFW-11 parameters has been customized for the Pump Genius Simplex application. Refer to the CFW-11 programming manual for more details on the parameters.

**Symbols for property description:**

<b>CFG</b>	Configuration parameter, value can be programmed only with motor stopped
<b>RO</b>	Read-only parameter
<b>RW</b>	Read and write parameter

#### 3.1 ORIGIN OF COMMANDS

This group of parameters allows the user to configure the origin of the CFW-11 inverter commands. For this application, the speed reference in LOCAL situation can be via HMI, and in REMOTE situation has to be via SOFTPLC to do the Pump Genius software works properly.

**LOCAL Situation:**

It allows the user to command the pump driven by the CFW-11 inverter disregarding the control of the speed reference from the Pump Genius logic.



**NOTE!**

The parameter P0205 (Reading Parameter Selection 1) is automatically changed to "1 - Speed-Reference #" when the CFW-11 inverter operates in LOCAL mode.

**REMOTE Situation:**

It enables the control of the speed reference from the Pump Genius logic according to the programming performed by the user.



**NOTE!**

The parameter P0205 (Reading Parameter Selection 1) is automatically changed to "22 – P1011 Control Setpoint #" when the CFW-11 inverter operates in REMOTE mode.

**P0220 – LOCAL/REMOTE Selection Source**

**P0221 – Speed Reference Selection – LOCAL Situation**

**P0222 – Speed Reference Selection – REMOTE Situation**

**P0223 – FORWARD/REVERSE Selection - LOCAL Situation**

**P0226 – FORWARD/REVERSE Selection - REMOTE Situation**

**P0224 – Run/Stop Selection – LOCAL Situation**

**P0227 – Run/Stop Selection – REMOTE Situation**

**P0225 – JOG Selection – LOCAL Situation**

**P0228 – JOG Selection – REMOTE Situation**





**NOTE!**

Refer to the CFW-11 inverter programming manual for more information on the command origin parameters. Some parameter options have been removed from the configuration wizard.

### 3.2 RAMPS

This group of parameters allows the user to adjust the inverter ramps, so that the motor can be accelerated or decelerated at a faster or slower rate.

#### P0100 – Acceleration Time

<b>Adjustable Range:</b>	0.0 to 999.0 s	<b>Factory Setting:</b>	20.0 s
<b>Properties:</b>			
<b>Access groups via HMI:</b>	<input type="text" value="01 PARAMETER GROUPS"/>		
	<input type="text" value="L 20 Ramps"/>		

**Description:**

This parameter determines the time of linear acceleration between zero and maximum speed (defined in P0134).

#### P0101 – Deceleration Time

<b>Adjustable Range:</b>	0.0 to 999.0 s	<b>Factory Setting:</b>	20.0 s
<b>Properties:</b>			
<b>Access groups via HMI:</b>	<input type="text" value="01 PARAMETER GROUPS"/>		
	<input type="text" value="L 20 Ramps"/>		

**Description:**

This parameter determines the time of linear deceleration between the maximum speed (defined in P0134) and zero.



**NOTE!**

Refer to the CFW-11 programming manual for more information on the ramp parameters.

### 3.3 SPEED LIMITS

This group of parameters allows the user to configure the motor speed limits.

#### P0133 – Minimum Speed Reference Limit

<b>Adjustable Range:</b>	0 to 18000 rpm	<b>Factory Setting:</b>	1200 rpm
<b>Properties:</b>			
<b>Access groups via HMI:</b>	<input type="text" value="01 PARAMETER GROUPS"/>		
	<input type="text" value="L 22 Speed Limits"/>		

**Description:**

This parameter defines the minimum value for the motor speed reference when the inverter is enabled.

#### P0134 – Maximum Speed Reference Limit

<b>Adjustable Range:</b>	0 to 18000 rpm	<b>Factory Setting:</b>	1800 rpm
<b>Properties:</b>			
<b>Access groups via HMI:</b>	<input type="text" value="01 PARAMETER GROUPS"/>		
	<input type="text" value="L 22 Speed Limits"/>		

## Parameters Description

### Description:

This parameter defines the maximum value for the motor speed reference when the inverter is enabled.



#### NOTE!

Refer to the CFW-11 programming manual for more information on the speed limit parameters. With the CFW-11 inverter programmed to scalar (V/f) mode, the motor slip is disregarded.

### 3.4 DIGITAL INPUTS

This group of parameters allows the user to configure the command function of each digital input in the Pump Genius Simplex application.

#### P0263 – DI1 Function

<b>Adjustable Range:</b>	0 to 31 / 21 = Enable use of the External Pump (PLC Use)	<b>Factory Setting:</b>	1
<b>Properties:</b>	CFG		
<b>Access groups via HMI:</b>	01 PARAMETER GROUPS └ 40 Digital Inputs	or	07 I/O CONFIGURATION └ 40 Digital Inputs

### Description:

This parameter configures the function of the digital input DI1 in the application ladder as enable the use of the external pump for jockey pump function (control the pumping when the demand is minimal). Additional switching elements can be inserted into the wiring of this digital input in order to perform protection functions, such as: a protection sensor for pump or motor, etc.

Logic level "0", disable the use of the external pump for jockey pump function.

Logic level "1", enable the use of the external pump for jockey pump function.



#### NOTE!

Refer to the section 3.13 for more information on the use of an external pump for jockey pump function.

#### P0264 – DI2 Function

<b>Adjustable Range:</b>	0 to 31 / 21 = Execute Deragging Function (PLC Use)	<b>Factory Setting:</b>	0
<b>Properties:</b>	CFG		
<b>Access groups via HMI:</b>	01 PARAMETER GROUPS └ 40 Digital Inputs	or	07 I/O CONFIGURATION └ 40 Digital Inputs

### Description:

This parameter configures the function of the digital input DI2 in the application ladder as the command to execute the deragging function.

When the transition from logic level "0" to "1" in the digital input DI2 occurs, it initiates the logic to execute the deragging function. At the end of the number of cycles set in P1053 parameter, the Pump Genius returns to normal operation.



#### NOTE!

Refer to the section 3.19 for more information on the deragging function.

## Parameters Description

### P0265 – DI3 Function

<b>Adjustable Range:</b>	0 to 31 / 21 = Sel. Control in Manual (0) or Automatic (1) (PLC Use)	<b>Factory Setting:</b>	0
<b>Properties:</b>	CFG		
<b>Access groups via HMI:</b>	<input type="text" value="01 PARAMETER GROUPS"/> or <input type="text" value="07 I/O CONFIGURATION"/> <input type="text" value="L 40 Digital Inputs"/>		

#### Description:

This parameter configures the function of the digital input DI3 in the application ladder as the selection the operation mode of PID controller in manual or automatic.

Logic level “0”, defines that the control (i.e., the PID controller) will operate in manual mode.

Logic level “1”, defines that the control (i.e., the PID controller) will operate in automatic mode.



#### NOTE!

Refer to the section 3.10 for more information on operation mode of PID controller.

### P0266 – DI4 Function

<b>Adjustable Range:</b>	0 to 31 / 21 = 1 <sup>st</sup> DI for Control Setpoint Selection (PLC Use)	<b>Factory Setting:</b>	0
<b>Properties:</b>	CFG		
<b>Access groups via HMI:</b>	<input type="text" value="01 PARAMETER GROUPS"/> or <input type="text" value="07 I/O CONFIGURATION"/> <input type="text" value="L 40 Digital Inputs"/>		

#### Description:

This parameter configures the function of the digital input DI4 in the application ladder as the 1<sup>st</sup> digital input of the logical combination which defines the control setpoint of the Pump Genius.

### P0267 – DI5 Function

<b>Adjustable Range:</b>	0 to 31 / 21 = 2 <sup>nd</sup> DI for Control Setpoint Selection (PLC Use)	<b>Factory Setting:</b>	0
<b>Properties:</b>	CFG		
<b>Access groups via HMI:</b>	<input type="text" value="01 PARAMETER GROUPS"/> or <input type="text" value="07 I/O CONFIGURATION"/> <input type="text" value="L 40 Digital Inputs"/>		

#### Description:

This parameter configures the function of the digital input DI5 in the application ladder as the 2<sup>nd</sup> digital input of the logical combination which defines the control setpoint of the Pump Genius.



#### NOTE!

Refer to the section 3.8 for more information on the control setpoint via logical combination of the digital inputs DI4 and DI5.

### P0268 – DI6 Function

<b>Adjustable Range:</b>	0 to 31 / 21 = External Sensor (PLC Use)	<b>Factory Setting:</b>	0
<b>Properties:</b>	CFG		
<b>Access groups via HMI:</b>	<input type="text" value="01 PARAMETER GROUPS"/> or <input type="text" value="07 I/O CONFIGURATION"/> <input type="text" value="L 40 Digital Inputs"/>		

#### Description:

This parameter configures the function of the digital input DI6 in the application ladder as enabling the pump protection via an external sensor.

## Parameters Description

Logic level “0” indicates that the external sensor for pump protection is actuated. When the pump is running, the alarm “A782: External Sensor for Pump Protection actuated” will be generated. After the programmed time in P1044 elapses, the fault “F783: External Sensor for Pump Protection actuated” will be generated, and the pump will be disabled.

Logic level “1” indicates that the condition for pump protection was not detected.



### NOTE!

Refer to the section 3.17 for more information on the pump protection via an external sensor.

### P0269 – DI7 Function

### P0270 – DI8 Function

<b>Adjustable</b>	0 to 31	<b>Factory Setting:</b>	0
<b>Range:</b>			
<b>Properties:</b>	CFG		
<b>Access groups via HMI:</b>	<input type="text" value="01 PARAMETER GROUPS"/> or <input type="text" value="07 I/O CONFIGURATION"/> <input type="text" value="L 40 Digital Inputs"/>		

### Description:

These parameters configure the function of digital input DI7 and DI8. It has no specific function in the Pump Genius Simplex application. It is necessary to install the IOB-01 accessory module in order to get access to these digital inputs.



### NOTE!

Refer to the CFW-11 programming manual for more information on the digital inputs parameters. Some parameter options have been removed from the configuration wizard.

## 3.5 DIGITAL OUTPUTS

This group of parameters allows the user to configure the command function of each digital output in the Pump Genius Simplex application.

### P0275 – DO1 Function (RL1)

<b>Adjustable</b>	0 to 36 / 28 = Start External Pump (SoftPLC)	<b>Factory Setting:</b>	13
<b>Range:</b>			
<b>Properties:</b>	CFG		
<b>Access groups via HMI:</b>	<input type="text" value="01 PARAMETER GROUPS"/> or <input type="text" value="07 I/O CONFIGURATION"/> <input type="text" value="L 41 Digital Outputs"/>		

### Description:

This parameter defines the function of the digital output DO1. If you selected the "28 = Start External Pump (SoftPLC)", the output assumes the function to start the external pump for jockey pump function. According to the section 2.6, a NO contact of the relay digital output must be used.

### P0276 – DO2 Function (RL2)

<b>Adjustable</b>	0 to 36 / 28 = Error in the RTC (Real Time Clock)	<b>Factory Setting:</b>	2
<b>Range:</b>			
<b>Properties:</b>	CFG		
<b>Access groups via HMI:</b>	<input type="text" value="01 PARAMETER GROUPS"/> or <input type="text" value="07 I/O CONFIGURATION"/> <input type="text" value="L 41 Digital Outputs"/>		

### Description:

This parameter defines the function of the digital output DO2. If you selected the "28 = Error in RTC (SoftPLC)", the output assumes the function to indicate the existence of an error on the real time clock (RTC) of the CFW-11 inverter. This error may be related to HMI of the CFW-11 inverter is poorly connected or the alarm "A181: Invalid Clock Value " have occurred.

## Parameters Description

### P0277 – DO3 Function (RL3)

<b>Adjustable Range:</b>	0 to 36 / 28 = With alarm A770/A772 or fault F771/F773 (SoftPLC)	<b>Factory Setting:</b>	1
<b>Properties:</b>	CFG		
<b>Access groups via HMI:</b>	<input type="text" value="01 PARAMETER GROUPS"/> or <input type="text" value="07 I/O CONFIGURATION"/> <input type="text" value="L 41 Digital Outputs"/>		

#### Description:

This parameter defines the function of the digital output DO3. If you selected the "28 = Alarm A770/A772 or Fault F771/F773 active (SoftPLC)", the output assumes the function of indicating that the alarm "A770: Low Level Alarm for the Control Process Variable" or "A772: High Level Alarm for the Control Process Variable" or "F771: Low Level Fault for the Control Process Variable" or "F773: High Level Fault for the Control Process Variable" is active. According to the chapter 2, a NO contact of the relay digital output must be used.

### P0278 – DO4 Function

### P0279 – DO5 Function

<b>Adjustable Range:</b>	0 to 36	<b>Factory Setting:</b>	P0278 = 0 P0279 = 0
<b>Properties:</b>	CFG		
<b>Access groups via HMI:</b>	<input type="text" value="01 PARAMETER GROUPS"/> or <input type="text" value="07 I/O CONFIGURATION"/> <input type="text" value="L 41 Digital Outputs"/>		

#### Description:

These parameters define the function of the digital outputs DO4 and DO5. It has no specific function in the Pump Genius Simplex application. It is necessary to install the IOB-01 accessory module to get access to the digital outputs DO4 and DO5.



#### NOTE!

Refer to the CFW-11 programming manual for more information on the digital outputs parameters.

## 3.6 ANALOG INPUTS

This group of parameters allows the user to configure the function of each analog input in the Pump Genius Simplex application.

### P0231 – AI1 Signal Function

### P0236 – AI2 Signal Function

### P0241 – AI3 Signal Function

### P0246 – AI4 Signal Function

<b>Adjustable Range:</b>	0 to 7 / 7 = Control Setpoint (PLC Use) (P1020 = 1 to 4)	<b>Factory Setting:</b>	P0231 = 7
<b>Range:</b>	0 to 7 / 7 = Control Process Variable (PLC Use) (P1021 = 1 to 5)		P0236 = 0
	0 to 7 / 7 = Control Auxiliary Variable (PLC Use) (P1047 = 1 to 4)		P0241 = 0
			P0246 = 0
<b>Properties:</b>	CFG		
<b>Access groups via HMI:</b>	<input type="text" value="01 PARAMETER GROUPS"/> or <input type="text" value="07 I/O CONFIGURATION"/> <input type="text" value="L 38 Analog Inputs"/>		

#### Description:

These parameters configure the function of the analog inputs AI1, AI2, AI3 and AI4 in the Pump Genius Simplex application as reading of the control setpoint (P1020=1 to 4), or as control process variable (P1021=1 to 5) or as control auxiliary variable (P1047=1 to 4).

## Parameters Description

### P0233 – AI1 Signal Type

### P0238 – AI2 Signal Type

### P0243 – AI3 Signal Type

### P0248 – AI4 Signal Type

**Adjustable** 0 = 0 to 10 V / 20 mA **Factory Setting:** 0  
**Range:**  
 1 = 4 to 20 mA  
 2 = 10 V / 20 mA to 0  
 3 = 20 to 4 mA

**Properties:**

**Access groups via HMI:**  or

**Description:**

These parameters configure the type of signal (voltage or current) that will be read at each analog input, as well as its range. According to the selected option adjust the DIP switch S1.4 (AI1) and S1.3 (AI2) of the CFW-11 control board, and the DIP switch S3.1 (AI3) and S3.2 (AI4) of the IOB-01 accessory module.

### P0232 – AI1 Gain

### P0237 – AI2 Gain

### P0242 – AI3 Gain

### P0247 – AI4 Gain

**Adjustable** 0.000 to 9.999 **Factory Setting:** 1.000  
**Range:**

**Properties:**

**Access groups via HMI:**  or

**Description:**

These parameters apply a gain to the value read at the analog inputs AI1, AI2, AI3 and AI4, i.e., the value obtained at the analog input is multiplied by the gain, thus allowing adjustments in the measured variable.

### P0234 – AI1 Offset

### P0239 – AI2 Offset

### P0244 – AI3 Offset

### P0249 – AI4 Offset

**Adjustable** -100.00 to +100.00 % **Factory Setting:** 0.00 %  
**Range:**

**Properties:**

**Access groups via HMI:**  or

**Description:**

These parameters add to the measured quantity a value, in percentage, in order to adjust the read variable.

## Parameters Description

### P0235 – AI1 Filter

### P0240 – AI2 Filter

### P0245 – AI3 Filter

### P0250 – AI4 Filter

**Adjustable Range:** 0.00 to 16.00 s **Factory Setting:** 0.25 s

**Properties:**

**Access groups via HMI:** 01 PARAMETER GROUPS or 07 I/O CONFIGURATION  
 L 38 Analog Inputs L 38 Analog Inputs

**Description:**

These parameters configure the 1<sup>st</sup> order filter time constant that will be applied to the analog inputs AI1, AI2, AI3 and AI4.



**NOTE!**

Refer to the CFW-11 programming manual for more information on the analog inputs parameters. Some parameter options have been removed from the configuration wizard.

## 3.7 CONTROL PROCESS VARIABLE

This group of parameters allows the user to configure the control process variable in the Pump Genius Simplex application.

### P1021 – Control Process Variable Selection Source

**Adjustable Range:** 0 = Without Control Process Variable (Disable the PID Controller) **Factory Setting:** 1  
 1 = Control Process Variable via Analog Input AI1  
 2 = Control Process Variable via Analog Input AI2  
 3 = Control Process Variable via difference between Analog Input AI1 and AI2  
 4 = Control Process Variable via Analog Input AI3  
 5 = Control Process Variable via Analog Input AI4

**Properties:**

**Access groups via HMI:** 01 PARAMETER GROUPS  
 L 50 SoftPLC

**Description:**

This parameter defines the source of the Pump Genius control process variable.

*Table 3.1 – Description of the control process variable source*

P1021	Description
0	It defines that there is no source for the control process variable of the Pump Genius, thereby disabling the PID controller. This enables the weekly schedule defines the speed reference for the pump driven by CFW-11 inverter according to the days of week rather than defines the control setpoint.
1	It defines that the source of the control process variable of the Pump Genius is the value read by the analog input AI1. The value is converted according to engineering unit 1 and displayed in parameter P1016.
2	It defines that the source of the control process variable of the Pump Genius is the value read by the analog input AI2. The value is converted according to engineering unit 1 and displayed in parameter P1016.
3	It defines that the source of the control process variable of the Pump Genius is the value read by the analog input AI1 subtracted from the value read by the analog input AI2. The value of AI1 – AI2 is converted according to engineering unit 1 and displayed in parameter P1016.
4	It defines that the source of the control process variable of the Pump Genius is the value read by the analog input AI3. The value is converted according to engineering unit 1 and displayed in parameter P1016.
5	It defines that the source of the control process variable of the Pump Genius is the value read by the analog input AI4. The value is converted according to engineering unit 1 and displayed in parameter P1016.

## Parameters Description

### 3.7.1 Engineering Unit Configuration

This group of parameters allows the user to configure the engineering unit of the Pump Genius control process variable.

#### P0510 – Engineering Unit 1

<b>Adjustable Range:</b>	<ul style="list-style-type: none"> <li>0 = None</li> <li>1 = V</li> <li>2 = A</li> <li>3 = rpm</li> <li>4 = s</li> <li>5 = ms</li> <li>6 = N</li> <li>7 = m</li> <li>8 = Nm</li> <li>9 = mA</li> <li>10 = %</li> <li>11 = °C</li> <li>12 = CV</li> <li>13 = Hz</li> <li>14 = HP</li> <li>15 = h</li> <li>16 = W</li> <li>17 = kW</li> <li>18 = kWh</li> <li>19 = H</li> <li>20 = min</li> <li>21 = °F</li> <li>22 = bar</li> <li>23 = mbar</li> <li>24 = psi</li> <li>25 = Pa</li> <li>26 = kPa</li> <li>27 = MPa</li> <li>28 = mwc (meter of water column)</li> <li>29 = mca (metro de columna d'agua)</li> <li>30 = gal</li> <li>31 = l (litro)</li> <li>32 = in</li> <li>33 = ft</li> <li>34 = m<sup>3</sup></li> <li>35 = ft<sup>3</sup></li> <li>36 = gal/s</li> <li>37 = GPM (= gal/min)</li> <li>38 = gal/h</li> <li>39 = l/s</li> <li>40 = l/min</li> <li>41 = l/h</li> <li>42 = m/s</li> <li>43 = m/min</li> <li>44 = m/h</li> <li>45 = ft/s</li> <li>46 = ft/min</li> <li>47 = ft/h</li> <li>48 = m<sup>3</sup>/s</li> <li>49 = m<sup>3</sup>/min</li> <li>50 = m<sup>3</sup>/h</li> <li>51 = ft<sup>3</sup>/s</li> <li>52 = CFM (= ft<sup>3</sup>/min)</li> <li>53 = ft<sup>3</sup>/h</li> <li>54 = kgf</li> </ul>	<b>Factory Setting:</b> 24
--------------------------	---	----------------------------



## Parameters Description

55 = kgfm  
 56 = lbf  
 57 = lbfft  
 58 = ohm  
 59 = rpm/s  
 60 = mH  
 61 = ppr  
 62 = °  
 63 = rot

### Properties:

#### Access groups via HMI:

01 PARAMETER GROUPS

└ 30 HMI

### Description:

This parameter selects the engineering unit that will be displayed in the SoftPLC user parameter that is associated with it. I.e., any SoftPLC user parameter that is associated with the engineering unit 1 will be displayed in this format on the CFW-11 inverter HMI.



#### NOTE!

The parameters P1011, P1012, P1013, P1014, P1015, P1016, P1022, P1023, P1024, P1026, P1034, P1035, P1039, P1050, P1060, P1061, P1066, P1069, P1072, P1075, P1078, P1081, P1084, P1087, P1090, P1093, P1096 and P1099 are associated with the engineering unit 1.

## P0511 – Decimal Point of Engineering Unit 1

### Adjustable

0 = xyzw

**Factory Setting:** 1

### Range:

1 = xyz.w

2 = xy.zw

3 = x.yzw

### Properties:

#### Access groups via HMI:

01 PARAMETER GROUPS

└ 30 HMI

### Description:

This parameter selects the decimal point that will be displayed in the SoftPLC user parameter that is associated with it. I.e., any SoftPLC user parameter that is associated with the decimal point of engineering unit 1 will be displayed in this format on the CFW-11 inverter HMI.



#### NOTE!

The parameters P1011, P1012, P1013, P1014, P1015, P1016, P1022, P1023, P1024, P1026, P1034, P1035, P1039, P1050, P1060, P1061, P1066, P1069, P1072, P1075, P1078, P1081, P1084, P1087, P1090, P1093, P1096 and P1099 are associated with decimal point of engineering unit 1.

### 3.7.2 Sensor Scale Configuration

This group of parameters allows the user to configure the scaling of the Pump Genius control process variable.

## P1022 – Control Process Variable Sensor Minimum Level

### Adjustable

-32768 to 32767 [Eng. Unit 1]

**Factory Setting:** 0

### Range:

### Properties:

#### Access groups via HMI:

01 PARAMETER GROUPS

└ 50 SoftPLC

### Description:

This parameter defines the minimum level of the Pump Genius control process variable sensor according to its engineering unit.

## Parameters Description

**NOTE!**

This parameter is displayed according to the selection of the engineering unit 1 parameters (P0510 and P0511).

### P1023 – Control Process Variable Sensor Maximum Level

<b>Adjustable Range:</b>	-32768 to 32767 [Eng. Unit 1]	<b>Factory Setting:</b>	400
<b>Properties:</b>	RW		
<b>Access groups via HMI:</b>	01 PARAMETER GROUPS L 50 SoftPLC		

**Description:**

This parameter defines the maximum level of the Pump Genius control process variable sensor according to its engineering unit.

**NOTE!**

This parameter is displayed according to the selection of the engineering unit 1 parameters (P0510 and P0511).

Through the minimum and maximum level of control process variable sensor and the value of analog input  $AI_x$ , we have the line equation for conversion of the Pump Genius control process variable:

$$P1016 = (P1023 - P1022) \times AI_x + P1022$$

Where,

P1016 = Control process variable;

P1022 = Minimum level of control process variable sensor;

P1023 = Maximum level of control process variable sensor;

$AI_x$  = Value of analog input AI1, AI2, AI3, AI4 or difference between AI1 and AI2 ( $AI1 - AI2$ ) in %.

### 3.8 CONTROL SETPOINT

This group of parameters allows the user to configure the control setpoint in the Pump Genius Simplex application.

### P1011 – Control Setpoint

<b>Adjustable Range:</b>	-32768 to 32767 [Eng. Unit 1]	<b>Factory Setting:</b>	200
<b>Properties:</b>	RW		
<b>Access groups via HMI:</b>	01 PARAMETER GROUPS L 50 SoftPLC		

**Description:**

This parameter defines the setpoint value in automatic mode for the Pump Genius in engineering units when the control setpoint source was programmed to be via HMI or communication networks ( $P1020 = 5$ ). When the control setpoint source was programmed to be another source ( $P1020 \neq 5$ ), it indicates the actual control setpoint in automatic mode of the Pump Genius.

**NOTE!**

This parameter is displayed according to the selection of the engineering unit 1 parameters (P0510 and P0511).

## Parameters Description

### P1012 – Control Setpoint 1

### P1013 – Control Setpoint 2

### P1014 – Control Setpoint 3

### P1015 – Control Setpoint 4

<b>Adjustable Range:</b>	-32768 to 32767 [Eng. Unit 1]	<b>Factory Setting:</b>	P1012 = 200 P1013 = 230 P1014 = 180 P1015 = 160
<b>Properties:</b>			
<b>Access groups via HMI:</b>	<input type="text" value="01 PARAMETER GROUPS"/> <input type="text" value="L 50 SoftPLC"/>		

#### Description:

These parameters define the value of the control setpoint in automatic mode of the Pump Genius in engineering units when the control setpoint source was programmed to be via logical combination of digital inputs DI4 and DI5 (P1020=6, 7 or 8) according the table 3.3.



#### NOTE!

These parameters are displayed according to the selection of the engineering unit 1 parameters (P0510 and P0511).

### P1020 – Control Setpoint Selection Source

<b>Adjustable Range:</b>	1 = Setpoint via Analog Input AI1 2 = Setpoint via Analog Input AI2 3 = Setpoint via Analog Input AI3 4 = Setpoint via Analog Input AI4 5 = Setpoint via HMI or Communication Networks (P1011) 6 = Two Setpoints via Digital Input DI4 (P1012 and P1013) 7 = Three Setpoints via Digital Inputs DI4 and DI5 (P1012, P1013 and P1014) 8 = Four Setpoints via Digital Inputs DI4 and DI5 (P1012, P1013, P1014 and P1015) 9 = Setpoint according to Weekly Schedule	<b>Factory Setting:</b>	5
<b>Properties:</b>			
<b>Access groups via HMI:</b>	<input type="text" value="01 PARAMETER GROUPS"/> <input type="text" value="L 50 SoftPLC"/>		

#### Description:

This parameter defines the source of the Pump Genius control setpoint.

*Table 3.2 – Description of the control setpoint source*

P1020	Description
1	It defines that the source of the control setpoint in automatic mode of the Pump Genius is the value read by the analog input AI1. The value is converted according to engineering unit 1 and displayed in parameter P1011.
2	It defines that the source of the control setpoint in automatic mode of the Pump Genius is the value read by the analog input AI2. The value is converted according to engineering unit 1 and displayed in parameter P1011.
3	It defines that the source of the control setpoint in automatic mode of the Pump Genius is the value read by the analog input AI3. The value is converted according to engineering unit 1 and displayed in parameter P1011.
4	It defines that the source of the control setpoint in automatic mode of the Pump Genius is the value read by the analog input AI4. The value is converted according to engineering unit 1 and displayed in parameter P1011.
5	It defines that the source of the control setpoint in automatic mode of the Pump Genius is the value programmed in the parameter P1011 via CFW-11 inverter HMI or writing via communication networks.
6	It defines that there are two control setpoints in automatic mode of the Pump Genius selected via logical combination of the digital input DI4. The control setpoint value selected is displayed in parameter P1011.
7	It defines that there are three control setpoints in automatic mode of the Pump Genius selected via logical combination of the digital inputs DI4 and DI5. The control setpoint value selected is displayed in parameter P1011.
8	It defines that there are four control setpoints in automatic mode of the Pump Genius selected via logical combination of the digital inputs DI4 and DI5. The control setpoint value selected is displayed in parameter P1011.

## Parameters Description

9	It defines that there the two to twelve control setpoints in automatic mode of the Pump Genius according to the weekly schedule, being each schedule based in the time and day of week controlled by the real time clock (RTC) of the CFW-11 inverter. The control setpoint value selected is displayed in parameter P1011.
---	---

When the control setpoint is via logical combination of the digital inputs DI4 and DI5, the following truth table should be applied for obtaining the control setpoint of the Pump Genius:

**Table 3.3** – Truth table for control setpoint via logical combination of the digital inputs DI4 and DI5

	P1012 – Control Setpoint 1	P1013 – Control Setpoint 2	P1014 – Control Setpoint 3	P1015 – Control Setpoint 4
Digital Input DI4	0	1	0	1
Digital Input DI5	0	0	1	1

### 3.9 WEEKLY SCHEDULE

This group of parameters allows the user to configure a weekly scheduling where, as the day of the week and time, the control setpoint or speed reference (PID controller is disabled (P1021 = 0 or P1028=0)) can have from two to twelve distinct values in the Pump Genius.

#### P1063 – Action Mode of Schedules according to the Day of Week

**Adjustable Range:** 0 = Disable Weekly Schedule (valid for P1021=0 or P1028=0) **Factory Setting:** 1  
 1 = Schedule 1 to 12 from Monday to Sunday  
 2 = Sched. 1 to 6 from Monday to Friday and Sched. 7 to 12 on Saturday and Sunday  
 3 = Sc. 1 to 4 from Monday to Friday, Sc. 5 to 8 on Saturday and Sc. 9 to 12 on Sunday

**Properties:**

**Access groups via HMI:** 01 PARAMETER GROUPS  
 L 50 SoftPLC

**Description:**

This parameter defines how the schedules 1 to 12 will be divided to compose the weekly schedule of change the control setpoint in automatic mode or the speed reference.



**NOTE!**

With the PID controller disabled (P1021=0 or P1028=0), it is possible enable the use of the schedule to define the two to twelve speed references to the Pump Genius.

**Table 3.4** – Description of the action mode of schedules according to the day of week

P1063	Description
0	It defines that the weekly schedule will not be used in the Pump Genius.
1	It defines that the schedules 1 to 12 will occur from Monday to Sunday.
2	It defines that the schedules 1 to 6 will occur from Monday to Friday and the schedules 7 to 12 will occur on Saturday and Sunday.
3	It defines that the schedules 1 to 4 will occur from Monday to Friday, the schedules 5 to 8 will occur on Saturday and the schedules 9 to 12 will occur on Sunday.

## Parameters Description

**P1064 – Hour to Start the Schedule 1**

**P1067 – Hour to Start the Schedule 2**

**P1070 – Hour to Start the Schedule 3**

**P1073 – Hour to Start the Schedule 4**

**P1076 – Hour to Start the Schedule 5**

**P1079 – Hour to Start the Schedule 6**

**P1082 – Hour to Start the Schedule 7**

**P1085 – Hour to Start the Schedule 8**

**P1088 – Hour to Start the Schedule 9**

**P1091 – Hour to Start the Schedule 10**

**P1094 – Hour to Start the Schedule 11**

**P1097 – Hour to Start the Schedule 12**

**Adjustable Range:** 0 to 24 h

**Factory Setting:**

P1064 =	04
P1067 =	09
P1070 =	17
P1073 =	22
P1076 =	24
P1079 =	24
P1082 =	24
P1085 =	24
P1088 =	24
P1091 =	24
P1094 =	24
P1097 =	24

**Properties:**

**Access groups via HMI:** 01 PARAMETER GROUPS  
 L 50 SoftPLC

**Description:**

These parameters define the hour value to start of each schedule, which then, will be active the respective control setpoint or speed reference. The end of each schedule is defined by the next schedule, since that the same be enabled.



**NOTE!**

A setting of “24” disables the use of the respective schedule and the next schedules. Each day of week should have at least two schedules active.

## Parameters Description

**P1065 – Minute to Start the Schedule 1**

**P1068 – Minute to Start the Schedule 2**

**P1071 – Minute to Start the Schedule 3**

**P1074 – Minute to Start the Schedule 4**

**P1077 – Minute to Start the Schedule 5**

**P1080 – Minute to Start the Schedule 6**

**P1083 – Minute to Start the Schedule 7**

**P1086 – Minute to Start the Schedule 8**

**P1089 – Minute to Start the Schedule 9**

**P1092 – Minute to Start the Schedule 10**

**P1095 – Minute to Start the Schedule 11**

**P1098 – Minute to Start the Schedule 12**

**Adjustable Range:** 0 to 59 min

**Factory Setting:** P1065 = 0  
P1068 = 0  
P1071 = 0  
P1074 = 0  
P1077 = 0  
P1080 = 0  
P1083 = 0  
P1086 = 0  
P1089 = 0  
P1092 = 0  
P1095 = 0  
P1098 = 0

**Properties:**

**Access groups via HMI:** 01 PARAMETER GROUPS  
L 50 SoftPLC

**Description:**

These parameters define the minute value to start of each schedule, which then, will be active the respective control setpoint or speed reference. The end of each schedule is defined by the next schedule, since that the same be enabled.

## Parameters Description

**P1066 – Control Setpoint / Speed Reference of Schedule 1**

**P1069 – Control Setpoint / Speed Reference of Schedule 2**

**P1072 – Control Setpoint / Speed Reference of Schedule 3**

**P1075 – Control Setpoint / Speed Reference of Schedule 4**

**P1078 – Control Setpoint / Speed Reference of Schedule 5**

**P1081 – Control Setpoint / Speed Reference of Schedule 6**

**P1083 – Control Setpoint / Speed Reference of Schedule 7**

**P1087 – Control Setpoint / Speed Reference of Schedule 8**

**P1090 – Control Setpoint / Speed Reference of Schedule 9**

**P1093 – Control Setpoint / Speed Reference of Schedule 10**

**P1096 – Control Setpoint / Speed Reference of Schedule 11**

**P1099 – Control Setpoint / Speed Reference of Schedule 12**

**Adjustable Range:** -32768 to 32767 [Eng. Unit 1] or rpm

**Factory Setting:**

P1066 =	200
P1069 =	240
P1072 =	280
P1075 =	140
P1078 =	0
P1081 =	0
P1084 =	0
P1087 =	0
P1090 =	0
P1093 =	0
P1096 =	0
P1099 =	0

**Properties:**

**Access groups via HMI:**

01 PARAMETER GROUPS

L 50 SoftPLC

**Description:**

These parameters define, to each schedule (1 to 12), a value of the control setpoint in automatic mode of the Pump Genius in engineering units when the control setpoint is set to according weekly schedule (P1020=9) or a value of pump speed reference in rpm when the PID controller is disabled (P1021=0 or P1028=0) and the action mode of schedules is enabled (P1063≠0).



**NOTE!**

These parameters are displayed according to the selection of the engineering unit 1 parameters (P0510 and P0511) when it is control setpoint or will be displayed in rpm when it is pump speed reference.



**NOTE!**

A setting of “0 rpm” executes the command to stop the pump. It is valid only when the parameter define the speed reference of the pump (P1021 = 0 or P1028=0 and P1063 ≠ 0).

The table 3.5 shows what schedule is active according to the hour and minute setting and mode of action according to the days of the week.

Table 3.5 – Table of start and end of each schedule according to the days of week

Hour and Minute to Start the Schedules	P1063 = 1		P1063 = 2		P1063 = 3	
	Start	End	Start	End	Start	End
<b>P1064 and P1065</b>	Schedule 1 (Monday to Sunday)	Schedule 12 (Monday to Sunday)	Schedule 1 (Monday to Friday)	Schedule 12 (Monday) Schedule 6 (Tuesday to Friday)	Schedule 1 (Monday to Friday)	Schedule 12 (Monday) Schedule 4 (Tuesday to Friday)
<b>P1067 and P1068</b>	Schedule 2 (Monday to Sunday)	Schedule 1 (Monday to Sunday)	Schedule 2 (Monday to Friday)	Schedule 1 (Monday to Friday)	Schedule 2 (Monday to Friday)	Schedule 1 (Monday to Friday)
<b>P1070 and P1071</b>	Schedule 3 (Monday to Sunday)	Schedule 2 (Monday to Sunday)	Schedule 3 (Monday to Friday)	Schedule 2 (Monday to Friday)	Schedule 3 (Monday to Friday)	Schedule 2 (Monday to Friday)
<b>P1073 and P1074</b>	Schedule 4 (Monday to Sunday)	Schedule 3 (Monday to Sunday)	Schedule 4 (Monday to Friday)	Schedule 3 (Monday to Friday)	Schedule 4 (Monday to Friday)	Schedule 3 (Monday to Friday)
<b>P1076 and P1077</b>	Schedule 5 (Monday to Sunday)	Schedule 4 (Monday to Sunday)	Schedule 5 (Monday to Friday)	Schedule 4 (Monday to Friday)	Schedule 5 (Saturday)	Schedule 4 (Saturday)
<b>P1079 and P1080</b>	Schedule 6 (Monday to Sunday)	Schedule 5 (Monday to Sunday)	Schedule 6 (Monday to Friday)	Schedule 5 (Monday to Friday)	Schedule 6 (Saturday)	Schedule 5 (Saturday)
<b>P1082 and P1083</b>	Schedule 7 (Monday to Sunday)	Schedule 6 (Monday to Sunday)	Schedule 7 (Saturday and Sunday)	Schedule 6 (Saturday) Schedule 12 (Sunday)	Schedule 7 (Saturday)	Schedule 6 (Saturday)
<b>P1085 and P1086</b>	Schedule 8 (Monday to Sunday)	Schedule 7 (Monday to Sunday)	Schedule 8 (Saturday and Sunday)	Schedule 7 (Saturday and Sunday)	Schedule 8 (Saturday)	Schedule 7 (Saturday)
<b>P1088 and P1089</b>	Schedule 9 (Monday to Sunday)	Schedule 8 (Monday to Sunday)	Schedule 9 (Saturday and Sunday)	Schedule 8 (Saturday and Sunday)	Schedule 9 (Sunday)	Schedule 8 (Sunday)
<b>P1091 and P1092</b>	Schedule 10 (Monday to Sunday)	Schedule 9 (Monday to Sunday)	Schedule 10 (Saturday and Sunday)	Schedule 9 (Saturday and Sunday)	Schedule 10 (Sunday)	Schedule 9 (Sunday)
<b>P1094 and P1095</b>	Schedule 11 (Monday to Sunday)	Schedule 10 (Monday to Sunday)	Schedule 11 (Saturday and Sunday)	Schedule 10 (Saturday and Sunday)	Schedule 11 (Sunday)	Schedule 10 (Sunday)
<b>P1097 and P1098</b>	Schedule 12 (Monday to Sunday)	Schedule 11 (Monday to Sunday)	Schedule 12 (Saturday and Sunday)	Schedule 11 (Saturday and Sunday)	Schedule 12 (Sunday)	Schedule 11 (Sunday)



3.9.1 Operation with Schedules 1 to 12 from Monday to Sunday (P1063=1)

Selecting the action mode of schedules according to the day of week (P1063) in 1, it is defined that the schedules 1 to 12 will occur from Monday to Sunday, i.e., will have only a scheduling that will valid for all days of week.

The figure 3.1 presents a timing analysis of the operation of schedules when the schedules 1 to 12 are defined to act sequentially from Monday to Sunday. The schedules 1 to 4 are enabled and the schedules 5 to 12 are disabled (P1076=24).

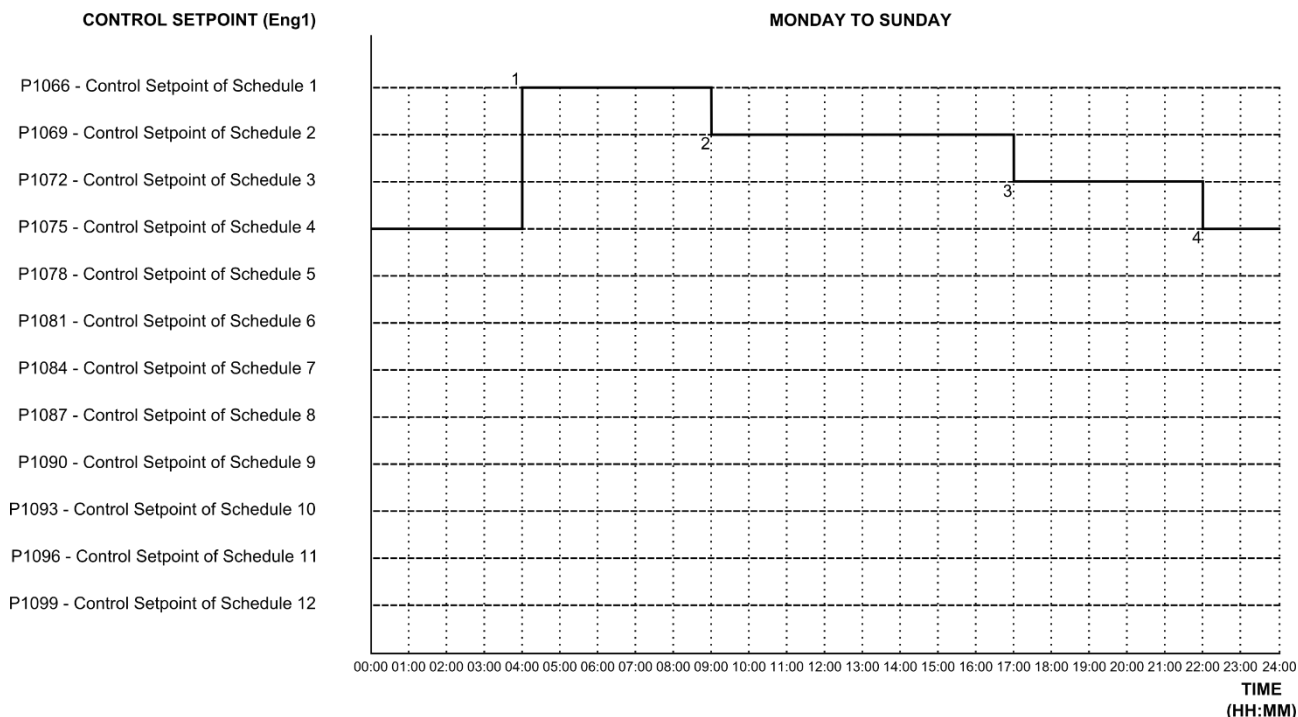

Figure 3.1 – Action of control setpoint according to schedules from Monday to Sunday

**1** – When the time of the CFW-11 inverter is equal to the hour (P1064) and the minute (1065) programmed to start the Schedule 1, the control setpoint (P1011) is changed to control setpoint of Schedule 1 defined in P1066 parameter. The control setpoint of Schedule 1 (P1066) will remain active in the Pump Genius until the moment of start the Schedule 2;

**2** – When the time of the CFW-11 inverter is equal to the hour (P1067) and the minute (1068) programmed to start the Schedule 2, the control setpoint (P1011) is changed to control setpoint of Schedule 2 defined in P1069 parameter. The control setpoint of Schedule 2 (P1069) will remain active in the Pump Genius until the moment of start the Schedule 3;

**3** – When the time of the CFW-11 inverter is equal to the hour (P1070) and the minute (1071) programmed to start the Schedule 3, the control setpoint (P1011) is changed to control setpoint of Schedule 3 defined in P1072 parameter. The control setpoint of Schedule 3 (P1072) will remain active in the Pump Genius until the moment of start the Schedule 4;

**4** – When the time of the CFW-11 inverter is equal to the hour (P1073) and the minute (1074) programmed to start the Schedule 4, the control setpoint (P1011) is changed to control setpoint of Schedule 4 defined in P1075 parameter. As this is the last schedule enabled, the control setpoint of Schedule 4 (P1075) will remain active in the Pump Genius until the moment of start the Schedule 1 in the next day.

## Parameters Description

### 3.9.2 Operation with Schedules 1 to 6 from Monday to Friday and Schedules 7 to 12 on Saturday and Sunday (P1063=2)

Selecting the action mode of schedules according to the day of week (P1063) in 2, is defined that the schedules 1 to 6 will occur from Monday to Friday and the schedules 7 to 12 will occur on Saturday and Sunday, i.e., will have two distinct ways of scheduling, one being valid from Monday to Friday and another valid for the weekend.

The figures 3.2, 3.3, 3.4 and 3.5 presents a timing analysis of the operation of schedules when the schedules 1 to 6 are defined to act sequentially from Monday to Friday and schedules 7 to 12 are defined to act sequentially on Saturday and Sunday. The schedules 1, 2, 3, 4, 7, 8, 9 and 10 are enabled and the schedules 5, 6, 11 and 12 are disabled (P1076=24 and P1094=24).

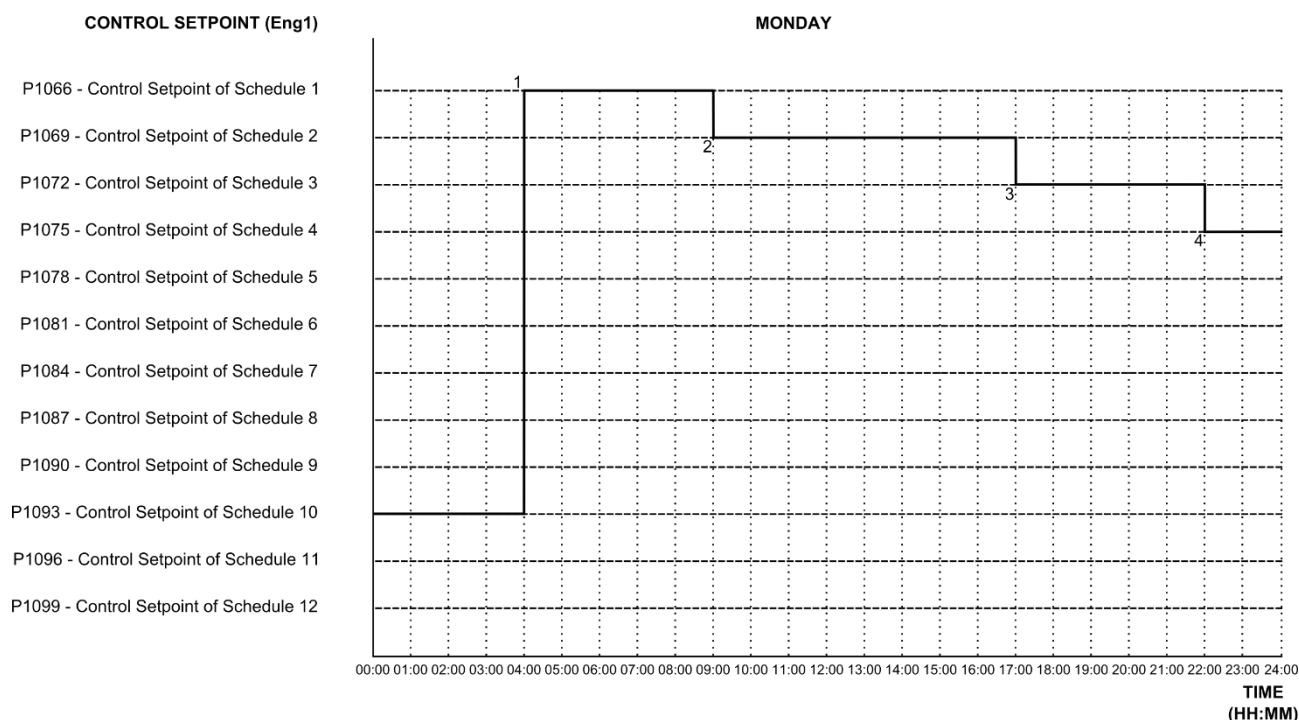

*Figure 3.2 – Action of control setpoint according to schedules on Monday*

**1** – When the time of the CFW-11 inverter is equal to the hour (P1064) and the minute (1065) programed to start the Schedule 1, the control setpoint (P1011) is changed to control setpoint of Schedule 1 defined in P1066 parameter. The control setpoint of Schedule 1 (P1066) will remain active in the Pump Genius until the moment of start the Schedule 2;

**2** – When the time of the CFW-11 inverter is equal to the hour (P1067) and the minute (1068) programed to start the Schedule 2, the control setpoint (P1011) is changed to control setpoint of Schedule 2 defined in P1069 parameter. The control setpoint of Schedule 2 (P1069) will remain active in the Pump Genius until the moment of start the Schedule 3;

**3** – When the time of the CFW-11 inverter is equal to the hour (P1070) and the minute (1071) programed to start the Schedule 3, the control setpoint (P1011) is changed to control setpoint of Schedule 3 defined in P1072 parameter. The control setpoint of Schedule 3 (P1072) will remain active in the Pump Genius until the moment of start the Schedule 4;

**4** – When the time of the CFW-11 inverter is equal to the hour (P1073) and the minute (1074) programed to start the Schedule 4, the control setpoint (P1011) is changed to control setpoint of Schedule 4 defined in P1075 parameter. As this is the last schedule enabled, the control setpoint of Schedule 4 (P1075) will remain active in the Pump Genius until the moment of start the Schedule 1 in the next day (Tuesday).

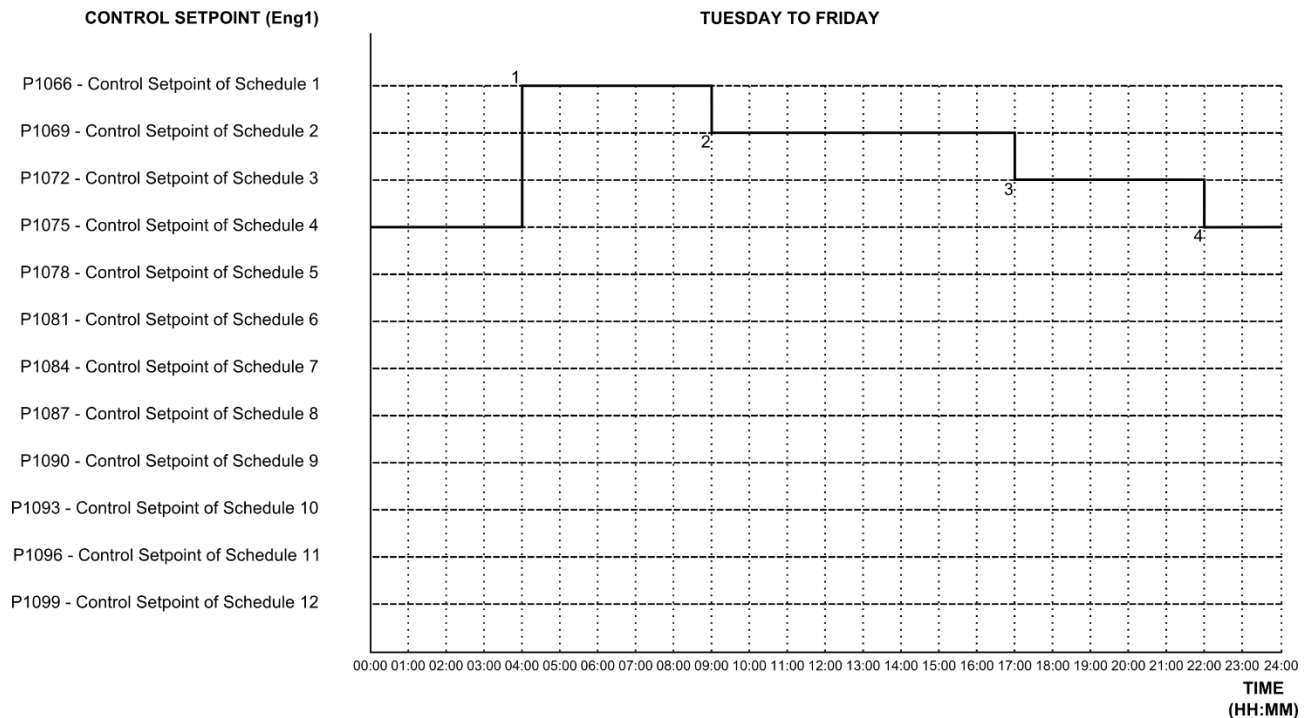

*Figure 3.3 – Action of control setpoint according to schedules from Tuesday to Friday*

**1** – When the time of the CFW-11 inverter is equal to the hour (P1064) and the minute (1065) programmed to start the Schedule 1, the control setpoint (P1011) is changed to control setpoint of Schedule 1 defined in P1066 parameter. The control setpoint of Schedule 1 (P1066) will remain active in the Pump Genius until the moment of start the Schedule 2;

**2** – When the time of the CFW-11 inverter is equal to the hour (P1067) and the minute (1068) programmed to start the Schedule 2, the control setpoint (P1011) is changed to control setpoint of Schedule 2 defined in P1069 parameter. The control setpoint of Schedule 2 (P1069) will remain active in the Pump Genius until the moment of start the Schedule 3;

**3** – When the time of the CFW-11 inverter is equal to the hour (P1070) and the minute (1071) programmed to start the Schedule 3, the control setpoint (P1011) is changed to control setpoint of Schedule 3 defined in P1072 parameter. The control setpoint of Schedule 3 (P1072) will remain active in the Pump Genius until the moment of start the Schedule 4;

**4** – When the time of the CFW-11 inverter is equal to the hour (P1073) and the minute (1074) programmed to start the Schedule 4, the control setpoint (P1011) is changed to control setpoint of Schedule 4 defined in P1075 parameter. As this is the last schedule enabled, the control setpoint of Schedule 4 (P1075) will remain active in the Pump Genius until the moment of start the Schedule 1 in the next day, except on Friday where the control setpoint will be active until the moment of start the Schedule 7 (Saturday).

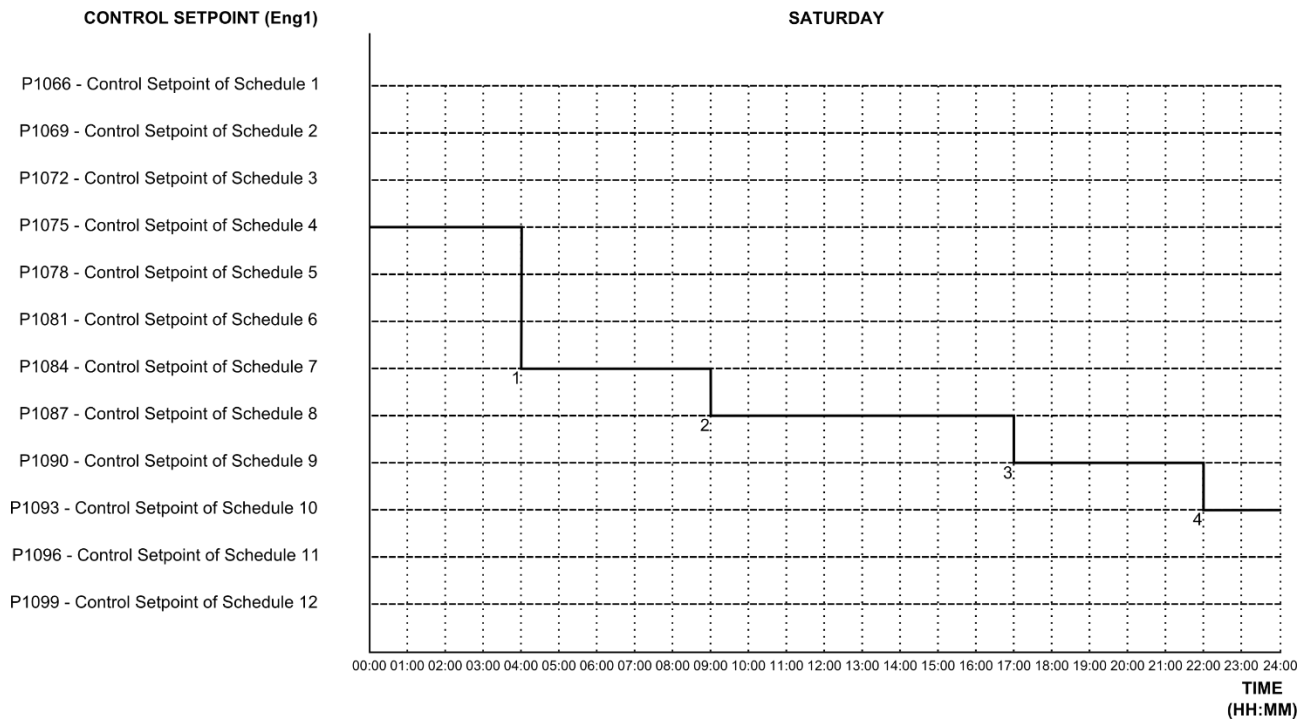

Figure 3.4 – Action of control setpoint according to schedules on Saturday

**1** – When the time of the CFW-11 inverter is equal to the hour (P1082) and the minute (1083) programed to start the Schedule 7, the control setpoint (P1011) is changed to control setpoint of Schedule 7 defined in P1084 parameter. The control setpoint of Schedule 7 (P1084) will remain active in the Pump Genius until the moment of start the Schedule 8;

**2** – When the time of the CFW-11 inverter is equal to the hour (P1085) and the minute (1086) programed to start the Schedule 8, the control setpoint (P1011) is changed to control setpoint of Schedule 8 defined in P1087 parameter. The control setpoint of Schedule 8 (P1087) will remain active in the Pump Genius until the moment of start the Schedule 9;

**3** – When the time of the CFW-11 inverter is equal to the hour (P1088) and the minute (1089) programed to start the Schedule 9, the control setpoint (P1011) is changed to control setpoint of Schedule 9 defined in P1090 parameter. The control setpoint of Schedule 9 (P1090) will remain active in the Pump Genius until the moment of start the Schedule 10;

**4** – When the time of the CFW-11 inverter is equal to the hour (P1091) and the minute (1092) programed to start the Schedule 10, the control setpoint (P1011) is changed to control setpoint of Schedule 10 defined in P1093 parameter. As this is the last schedule enabled, the control setpoint of Schedule 10 (P1093) will remain active in the Pump Genius until the moment of start the Schedule 7 in the next day (Sunday).

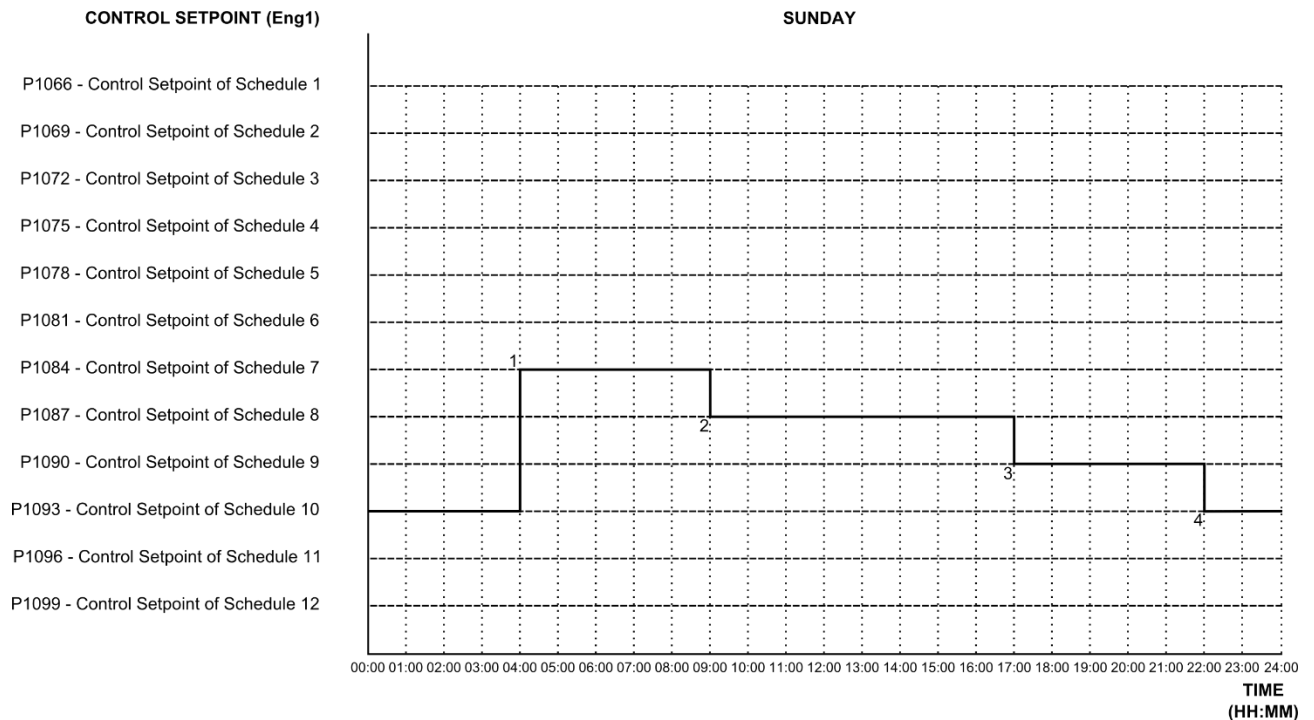

*Figure 3.5 – Action of control setpoint according to schedules on Sunday*

**1** – When the time of the CFW-11 inverter is equal to the hour (P1082) and the minute (1083) programmed to start the Schedule 7, the control setpoint (P1011) is changed to control setpoint of Schedule 7 defined in P1084 parameter. The control setpoint of Schedule 7 (P1084) will remain active in the Pump Genius until the moment of start the Schedule 8;

**2** – When the time of the CFW-11 inverter is equal to the hour (P1085) and the minute (1086) programmed to start the Schedule 8, the control setpoint (P1011) is changed to control setpoint of Schedule 8 defined in P1087 parameter. The control setpoint of Schedule 8 (P1087) will remain active in the Pump Genius until the moment of start the Schedule 9;

**3** – When the time of the CFW-11 inverter is equal to the hour (P1088) and the minute (1089) programmed to start the Schedule 9, the control setpoint (P1011) is changed to control setpoint of Schedule 9 defined in P1090 parameter. The control setpoint of Schedule 9 (P1090) will remain active in the Pump Genius until the moment of start the Schedule 10;

**4** – When the time of the CFW-11 inverter is equal to the hour (P1091) and the minute (1092) programmed to start the Schedule 10, the control setpoint (P1011) is changed to control setpoint of Schedule 10 defined in P1093 parameter. As this is the last schedule enabled, the control setpoint of Schedule 10 (P1093) will remain active in the Pump Genius until the moment of start the Schedule 1 in the next day (Monday).

## Parameters Description

### 3.9.3 Operation with Schedules 1 to 4 from Monday to Friday and Schedules 5 to 8 on Saturday and Schedules 9 to 12 on Sunday (P1063=3)

Selecting the action mode of schedules according to the day of week (P1063) in 3, is defined that the schedules 1 to 4 will occur from Monday to Friday and schedules 5 to 8 will occur on Saturday and schedules 9 to 12 will occur on Sunday, i.e., will have three distinct ways of scheduling, one being valid from Monday to Friday, other valid for Saturday and other valid for Sunday.

The figures 3.6, 3.7, 3.8 and 3.9 presents a timing analysis of the operation of schedules when the schedules 1 to 4 are defined to act sequentially from Monday to Friday, schedules 5 to 8 are defined to act sequentially on Saturday and schedules 9 to 12 are defined to act sequentially on Sunday. All schedules (1 to 12) are enabled.

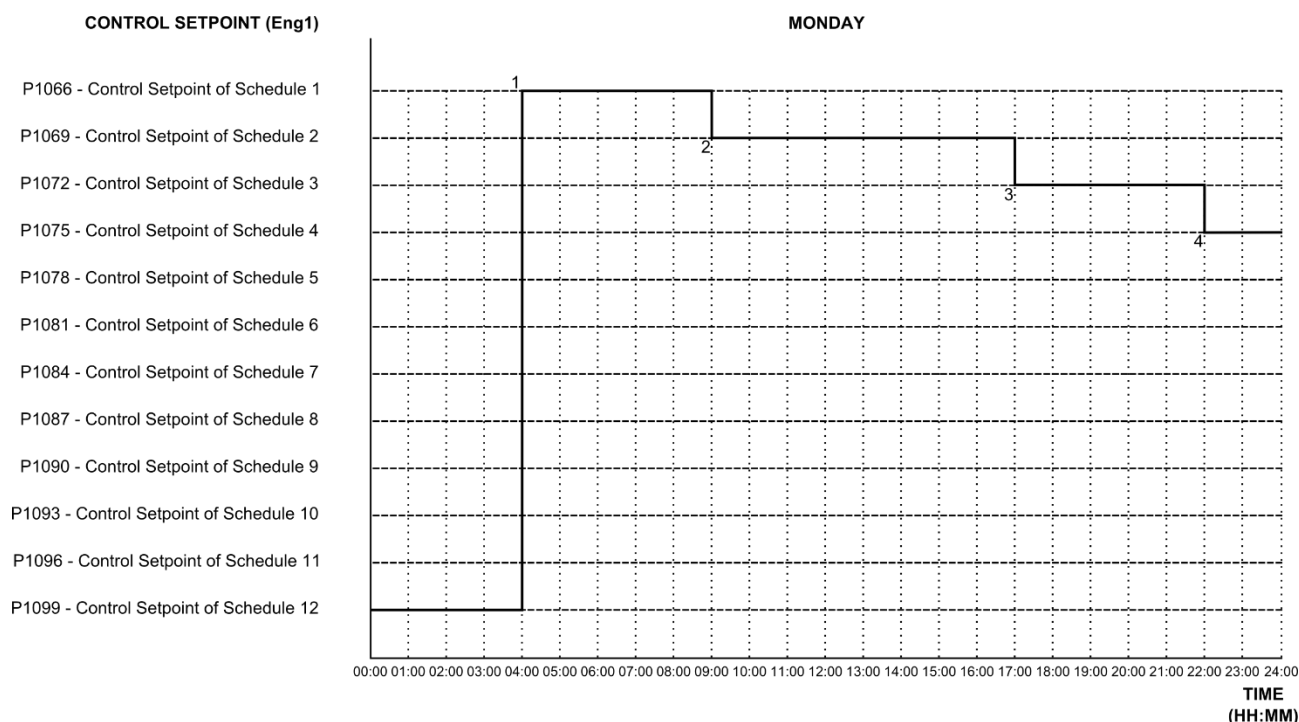

*Figure 3.6 – Action of control setpoint according to schedules on Monday*

**1** – When the time of the CFW-11 inverter is equal to the hour (P1064) and the minute (1065) programed to start the Schedule 1, the control setpoint (P1011) is changed to control setpoint of Schedule 1 defined in P1066 parameter. The control setpoint of Schedule 1 (P1066) will remain active in the Pump Genius until the moment of start the Schedule 2;

**2** – When the time of the CFW-11 inverter is equal to the hour (P1067) and the minute (1068) programed to start the Schedule 2, the control setpoint (P1011) is changed to control setpoint of Schedule 2 defined in P1069 parameter. The control setpoint of Schedule 2 (P1069) will remain active in the Pump Genius until the moment of start the Schedule 3;

**3** – When the time of the CFW-11 inverter is equal to the hour (P1070) and the minute (1071) programed to start the Schedule 3, the control setpoint (P1011) is changed to control setpoint of Schedule 3 defined in P1072 parameter. The control setpoint of Schedule 3 (P1072) will remain active in the Pump Genius until the moment of start the Schedule 4;

**4** – When the time of the CFW-11 inverter is equal to the hour (P1073) and the minute (1074) programed to start the Schedule 4, the control setpoint (P1011) is changed to control setpoint of Schedule 4 defined in P1075 parameter. The control setpoint of Schedule 4 (P1075) will remain active in the Pump Genius until the moment of start the Schedule 1 in the next day (Tuesday).



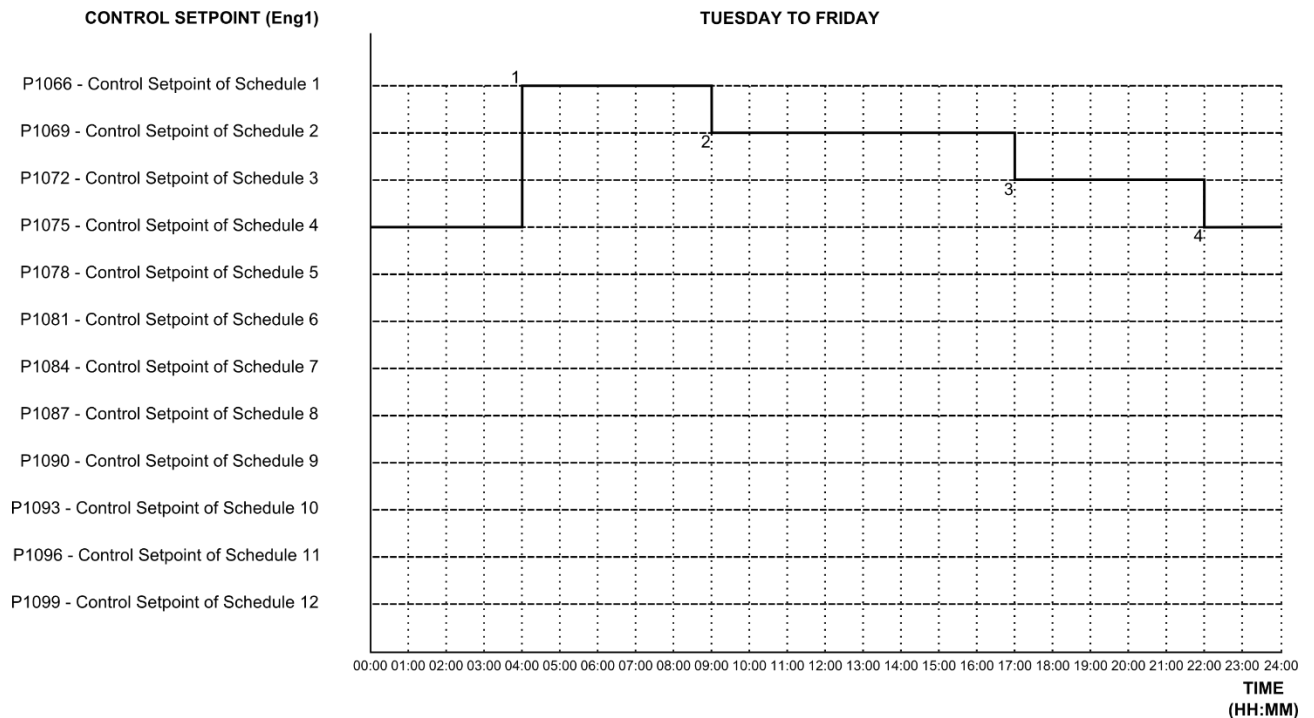

*Figure 3.7 – Action of control setpoint according to schedules from Tuesday to Friday*

**1** – When the time of the CFW-11 inverter is equal to the hour (P1064) and the minute (1065) programmed to start the Schedule 1, the control setpoint (P1011) is changed to control setpoint of Schedule 1 defined in P1066 parameter. The control setpoint of Schedule 1 (P1066) will remain active in the Pump Genius until the moment of start the Schedule 2;

**2** – When the time of the CFW-11 inverter is equal to the hour (P1067) and the minute (1068) programmed to start the Schedule 2, the control setpoint (P1011) is changed to control setpoint of Schedule 2 defined in P1069 parameter. The control setpoint of Schedule 2 (P1069) will remain active in the Pump Genius until the moment of start the Schedule 3;

**3** – When the time of the CFW-11 inverter is equal to the hour (P1070) and the minute (1071) programmed to start the Schedule 3, the control setpoint (P1011) is changed to control setpoint of Schedule 3 defined in P1072 parameter. The control setpoint of Schedule 3 (P1072) will remain active in the Pump Genius until the moment of start the Schedule 4;

**4** – When the time of the CFW-11 inverter is equal to the hour (P1073) and the minute (1074) programmed to start the Schedule 4, the control setpoint (P1011) is changed to control setpoint of Schedule 4 defined in P1075 parameter. The control setpoint of Schedule 4 (P1075) will remain active in the Pump Genius until the moment of start the Schedule 1 in the next day, except on Friday where the control setpoint will be active until the moment of start the Schedule 5 (Saturday).

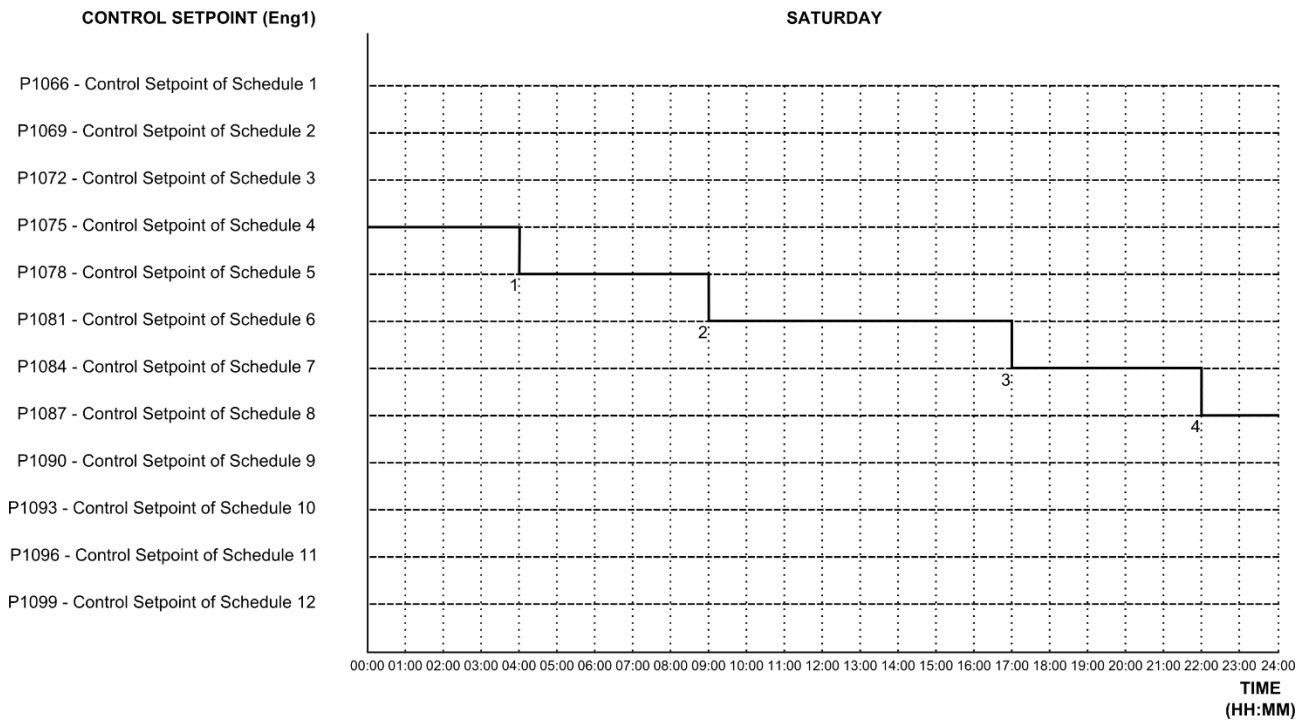

Figure 3.8 – Action of control setpoint according to schedules on Saturday

1 – When the time of the CFW-11 inverter is equal to the hour (P1076) and the minute (1077) programed to start the Schedule 5, the control setpoint (P1011) is changed to control setpoint of Schedule 5 defined in P1078 parameter. The control setpoint of Schedule 5 (P1078) will remain active in the Pump Genius until the moment of start the Schedule 6;

2 – When the time of the CFW-11 inverter is equal to the hour (P1079) and the minute (1080) programed to start the Schedule 6, the control setpoint (P1011) is changed to control setpoint of Schedule 6 defined in P1081 parameter. The control setpoint of Schedule 6 (P1081) will remain active in the Pump Genius until the moment of start the Schedule 7;

3 – When the time of the CFW-11 inverter is equal to the hour (P1082) and the minute (1083) programed to start the Schedule 7, the control setpoint (P1011) is changed to control setpoint of Schedule 7 defined in P1084 parameter. The control setpoint of Schedule 7 (P1084) will remain active in the Pump Genius until the moment of start the Schedule 8;

4 – When the time of the CFW-11 inverter is equal to the hour (P1085) and the minute (1086) programed to start the Schedule 8, the control setpoint (P1011) is changed to control setpoint of Schedule 8 defined in P1087 parameter. The control setpoint of Schedule 8 (P1087) will remain active in the Pump Genius until the moment of start the Schedule 9 in the next day (Sunday).



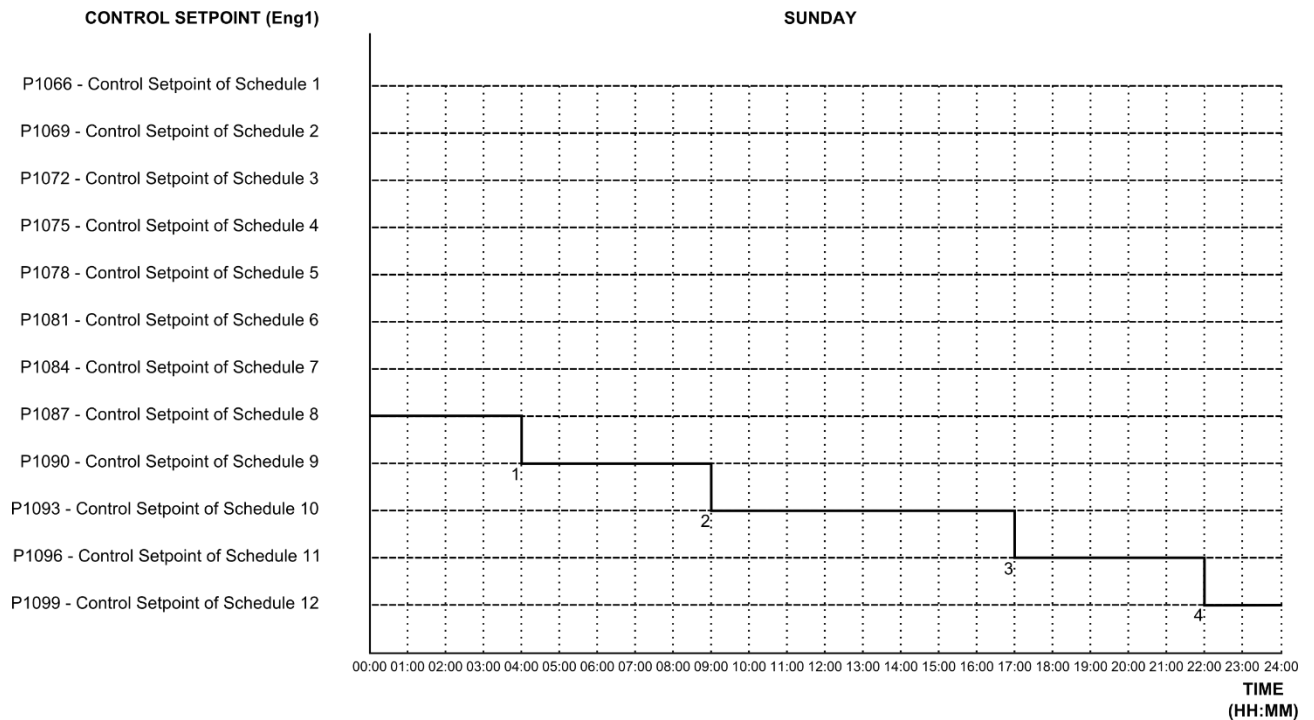

*Figure 3.9 – Action of control setpoint according to schedules on Sunday*

**1** – When the time of the CFW-11 inverter is equal to the hour (P1088) and the minute (1089) programmed to start the Schedule 9, the control setpoint (P1011) is changed to control setpoint of Schedule 9 defined in P1090 parameter. The control setpoint of Schedule 9 (P1090) will remain active in the Pump Genius until the moment of start the Schedule 10;

**2** – When the time of the CFW-11 inverter is equal to the hour (P1091) and the minute (1092) programmed to start the Schedule 10, the control setpoint (P1011) is changed to control setpoint of Schedule 10 defined in P1093 parameter. The control setpoint of Schedule 10 (P1093) will remain active in the Pump Genius until the moment of start the Schedule 11;

**3** – When the time of the CFW-11 inverter is equal to the hour (P1094) and the minute (1095) programmed to start the Schedule 11, the control setpoint (P1011) is changed to control setpoint of Schedule 11 defined in P1096 parameter. The control setpoint of Schedule 11 (P1096) will remain active in the Pump Genius until the moment of start the Schedule 12;

**4** – When the time of the CFW-11 inverter is equal to the hour (P1097) and the minute (1098) programmed to start the Schedule 12, the control setpoint (P1011) is changed to control setpoint of Schedule 12 defined in P1099 parameter. The control setpoint of Schedule 12 (P1099) will remain active in the Pump Genius until the moment of start the Schedule 1 in the next day (Monday).

## Parameters Description

### 3.10 PID CONTROLLER

This group of parameters allows the user to adjust the operating conditions of the PID controller for controlling the pumping.

The PID controller can control the motor (pump) speed driven by CFW-11 inverter through the comparison of the control process variable (feedback) with the control setpoint required by the user.

The PID controller will be set up to operate from 0.0 to 100.0 %, where 0.0 % equates to minimum speed programmed in P0133 and 100.0 % equates to maximum speed programmed in P0134.

The control process variable is read via an analog input, which requires the chosen input to be appropriately configured for the purpose.

The "Academic" structure has been adopted as algorithm for the PID controller. It obeys the following equation:

$$u(k) = i(k-1) + K_p \cdot [(1 + K_i \cdot T_s + (K_d/T_s)) \cdot e(k) - (K_d/T_s) \cdot e(k-1)]$$

Where,

$u(k)$  = PID controller output

$i(k-1)$  = integral part in the previous sampling instant

$K_p$  = proportional gain

$K_i$  = integral gain

$K_d$  = derivative gain

$T_s$  = cyclic sampling time (fixed at 50ms)

$e(k)$  = error in the present sampling instant (setpoint – process variable (direct), or process variable – setpoint (reverse))

$e(k-1)$  = error in the previous sampling instant

#### P1018 – Setpoint of the PID Controller in Manual mode

**Adjustable** 0 to 18000 rpm **Factory Setting:** 0

**Range:**

**Proprieties:**

**Access groups via HMI:** 01 PARAMETER GROUPS

L 50 SoftPLC

#### Description:

This parameter defines the PID controller setpoint value when it is operating in manual mode. When the PID controller operates in manual mode, the speed value set in parameter P1018 (setpoint in manual mode) is transferred directly to the PID controller output, thus defining the speed reference of the pump driven by the CFW-11 inverter.

#### P1028 – Selection of Control Action of the PID Controller

**Adjustable** 0 = Disable the PID Controller **Factory Setting:** 1

**Range:**  
1 = Direct Mode  
2 = Reverse Mode

**Properties:** CFG

**Access groups via HMI:** 01 PARAMETER GROUPS

L 50 SoftPLC

#### Description:

This parameter defines the control action of the PID controller for the Pump Genius when it is enabled. I.e. it defines how will be the error signal.

## Parameters Description

*Table 3.6 – Description of the control action of the PID controller*

P1028	Description
0	It defines that the PID controller will be disabled. I.e., will not have control of the process variable.
1	It defines that the control or regulation action of the PID controller will be in direct mode. I.e., the error is the control setpoint value (P1011) minus the control process variable value (P1016).
2	It defines that the control or regulation action of the PID controller will be in reverse mode. I.e., the error is the control process variable value (P1016) minus the control setpoint value (P1011).



### NOTE!

The PID control action should be set to direct mode, when, in order to increase the control process variable value, it is necessary to increase the PID output. Ex: Pump driven by the inverter is filling a reservoir. Raising the reservoir level (control process variable), requires a higher flow rate, which is achieved by increasing the motor speed.

The PID control action should be selected to reverse mode, when, in order to increase the control process variable value, it is necessary to reduce the PID output. Ex: Pump driven by the inverter is removing fluid from a reservoir. In order to increase the fluid level in the reservoir (control process variable), it is necessary to reduce the pump speed by reducing the motor speed.

## P1029 – Operation Mode of the PID Controller

**Adjustable** 0 = Manual **Factory Setting:** 1  
**Range:** 1 = Automatic  
 2 = Manual or Automatic selection via digital input DI3

### Properties:

**Access groups via HMI:** 01 PARAMETER GROUPS  
 L 50 SoftPLC

### Description:

This parameter defines the operation mode of the PID controller for the Pump Genius.

*Table 3.7 – Description of operation mode of the PID controller*

P1029	Description
0	It defines that the PID controller will operate in manual mode. I.e., the process variable will not be controlled as the control setpoint required by the user and the PID controller output value will be the setpoint value in manual mode set in parameter P1018.
1	It defines that the PID controller will operate in automatic mode. I.e., the process variable will be controlled as the control setpoint required by the user and the output value of the PID controller will behave as the setting defined by de user.
2	It defines that the PID controller can operate in manual or automatic mode according to the state of digital input DI3. I.e., if the digital input is in logic level "0", the PID controller will operate in manual mode; if the digital input is in logic level "1" the PID controller will operate in automatic mode.



### NOTE!

The change from one operation mode to another with the Pump Genius in operation can cause disturbances in the pumping control. This can be optimized as the automatic adjustment of the PID controller setpoint defined in P1030 parameter together with the bumpless transfer characteristic from manual to automatic mode of the SoftPLC PID block.

The Bumpless transfer is merely making the transfer from the manual mode to the automatic mode without causing variation in the PID controller output. I.e., when the transition occurs from the manual mode to the automatic mode, the PID controller output value in manual mode is used to start the integral part of the PID controller. That ensures that the output will start from this value.

## Parameters Description

### P1030 – Automatic Adjustment of the PID Controller Setpoint

**Adjustable** 0 = P1011 Off and P1018 Off **Padrão:** 0  
**Range:** 1 = P1011 On and P1018 Off  
 2 = P1011 Off and P1018 On  
 3 = P1011 On and P1018 On

**Properties:**

**Access groups via HMI:** 01 PARAMETER GROUPS  
 L 50 SoftPLC

**Description:**

This parameter defines if the setpoint of the PID controller in automatic mode (P1011) and / or manual mode (P1018) will be changed or adjusted automatically in change of operation mode of the PID controller.



**NOTE!**

The adjustment of the control setpoint in automatic mode is only valid when the control setpoint source is set to HMI or communication networks (P1020 = 5). For other control setpoint sources, the automatic adjust of the control setpoint is not executed.

*Table 3.8 – Description of automatic adjustment of the PID controller setpoint*

P1030	Description
0	It defines that in the transition of the PID controller operation mode from manual to automatic, the control setpoint value (P1011) is <b>not</b> loaded with the current value of the control process variable (P1016); and that in the transition of the PID controller operation mode from automatic to manual, the PID controller setpoint value in manual mode (P1018) is <b>not</b> loaded with the current value of the pump motor speed (P0002).
1	It defines that in the transition of the PID controller operation mode from manual to automatic, the control setpoint value (P1011) <b>will be</b> loaded with the current value of the control process variable (P1016); and that in the transition of the PID controller operation mode from automatic to manual, the PID controller setpoint value in manual mode (P1018) is <b>not</b> loaded with the current value of the pump motor speed (P0002).
2	It defines that in the transition of the PID controller operation mode from manual to automatic, the control setpoint value (P1011) is <b>not</b> loaded with the current value of the control process variable (P1016); and that in the transition of the PID controller operation mode from automatic to manual, the PID controller setpoint value in manual mode (P1018) <b>will be</b> loaded with the current value of the pump motor speed (P0002).
3	It defines that in the transition of the PID controller operation mode from manual to automatic, the control setpoint value (P1011) <b>will be</b> loaded with the current value of the control process variable (P1016); and that in the transition of the PID controller operation mode from automatic to manual, the PID controller setpoint value in manual mode (P1018) <b>will be</b> loaded with the current value of the pump motor speed (P0002).

### P1031 – PID Proportional Gain

**Adjustable** 0.000 to 32.000 **Factory Setting:** 1.000

**Range:**

**Properties:**

**Access groups via HMI:** 01 PARAMETER GROUPS  
 L 50 SoftPLC

**Description:**

This parameter defines the proportional gain value of the PID controller of the Pump Genius.

### P1032 – PID Integral Gain

**Adjustable** 0.000 to 32.000 **Factory Setting:** 5.000

**Range:**

**Properties:**

**Access groups via HMI:** 01 PARAMETER GROUPS  
 L 50 SoftPLC

**Description:**

This parameter defines the integral gain value of the PID controller of the Pump Genius.

## Parameters Description

### P1033 – PID Derivative Gain

**Adjustable** 0.000 to 32.000 **Factory Setting:** 0.000

**Range:**

**Properties:**

**Access groups via HMI:** 01 PARAMETER GROUPS

└ 50 SoftPLC

#### Description:

This parameter defines the derivative gain value of the PID controller of the Pump Genius.



#### NOTE!

The PID controller of the standard Pump Genius Simplex application is of the academic type. Should a different structure be adopted for the PID controller (through WLP), then the controller gains must be re-optimized by the user. PID block input arguments can only be changed in the ladder application developed with the WLP. Refer to the WLP programming software help topics for more information on the PID block.

### 3.11 STARTUP MODES

It defines the conditions to startup the Pump Genius.

#### 3.11.1 Wake up and Start Level Mode

This group of parameters allows the user to set the conditions to startup and control the pumping, and it may be:

- **Wake up Mode:** Configures the Pump Genius to start the pump and resume control of the pumping when the deviation between the control process variable and the control setpoint reaches a programmed threshold;
- **Start Level Mode:** Configures the Pump Genius to start the pump and resume control of the pumping when the control process variable reaches a programmed threshold;

### P1034 – Control Process Variable Deviation to Wake up the Pump Genius

**Adjustable** -32768 to 32767 [Eng. Un. 1] **Factory Setting:** 30

**Range:**

**Properties:**

**Access groups via HMI:** 01 PARAMETER GROUPS

└ 50 SoftPLC

#### Description:

This parameter defines the value to be reduced (direct PID) or increased (reverse PID) to the control setpoint for starting the pump and resuming control of the pumping. Becoming this value is compared with the control process variable and, if the value of the control process variable is less (direct PID) or greater (reverse PID) than this value, the condition to wake up is enabled.



#### NOTE!

This parameter is displayed according to the selection of the engineering unit 1 parameters (P0510 and P0511).

### P1035 – Control Process Variable Level for Starting the Pump Genius

**Adjustable** -32768 to 32767 [Eng. Un. 1] **Factory Setting:** 180

**Range:**

**Properties:**

**Access groups via HMI:** 01 PARAMETER GROUPS

└ 50 SoftPLC

## Parameters Description

### Description:

This parameter defines the control process variable level for starting the pump and resuming control of the pumping. With a Direct Mode PID controller, the pumping control will be enabling to start when the control process variable drops lower than P1035. With a Reverse Mode PID controller it will be enabling to start when the process variable rises above P1035.



#### NOTE!

This parameter is displayed according to the selection of the engineering unit 1 parameters (P0510 and P0511).

### P1036 – Time Delay to Wake up or Starting by Level the Pump Genius

**Adjustable** 0 to 32767 s **Factory Setting:** 5 s

#### Range:

#### Properties:

**Access groups via HMI:** 01 PARAMETER GROUPS  
L 50 SoftPLC

### Description:

This parameter defines the waiting time after the condition for wake up mode or start level mode becomes true, as follows:

- **Wake up Mode:** The Wake up condition, as defined in P1034, must remain TRUE continuously for the time programmed in P1036, in order for the pump to start and pumping control to resume. The P1036 waiting time restarts from zero, if the Wake up condition momentarily becomes FALSE.
- **Start Level Mode:** The control process variable Start Level condition, as defined in P1035, must remain TRUE continuously for the time programmed in P1036, in order for the pump to start and pumping control to resume. The P1036 waiting time restarts from zero, if the Start Level condition momentarily becomes FALSE.



#### NOTE!

If in enabling of the Pump Genius operation (command Run/Stop active), the condition for Wake up or Start by Level is active, the time set in P1036 is not awaited, and thus, the pump will start operating immediately.

### 3.11.2 Sleep Mode and Sleep Boost

This group of parameters allows the user to set the conditions to stop the pump, and it may be:

- **Sleep Mode:** Configures the Pump Genius to stop the pump when the pump motor speed drops below a programmed threshold (low control demand). Even though apparently the pumping control is off, the control process variable is still monitored for wake up or start level conditions.
- **Sleep Boost:** Configures the Pump Genius so before stop the pump when the pump motor speed drops below a programmed threshold (low demand control), i.e., enable the sleep mode, to be added to the control setpoint a value to increase the control process variable with the purpose of the pump will remain in sleep mode longer.

### P1037 – Pump Motor Speed below which Pump Genius goes to Sleep Mode

**Adjustable** 0 to 18000 rpm **Factory Setting:** 1250 rpm

#### Range:

#### Properties:

**Access groups via HMI:** 01 PARAMETER GROUPS  
L 50 SoftPLC

### Description:

This parameter defines the value of the pump motor speed below which the Pump Genius will stop the pump keeping the control active, i.e., will sleep.

## Parameters Description



### NOTE!

A setting of "0 rpm" disables the sleep mode, it means that the pump will be started or stopped according to the status of the command "Run/Stop".

### P1038 – Time Delay for Pump Genius goes to Sleep Mode

**Adjustable** 0 to 32767 s **Factory Setting:** 10 s

**Range:**

**Properties:**

**Access groups via HMI:** 01 PARAMETER GROUPS

L 50 SoftPLC

#### Description:

This parameter defines the waiting time with the value of the pump motor speed should remain below the value set in P1037 in order for sleep mode to be activated and the pump to be stopped.



### NOTE!

The alarm message "A750: Sleep Mode Active" will be generated on the HMI of the CFW-11 inverter to alert that the Pump Genius is in sleep mode.

### P1039 – Sleep Boost Offset

**Adjustable** -32768 to 32767 [Eng. Un. 1] **Factory Setting:** 0

**Range:**

**Properties:**

**Access groups via HMI:** 01 PARAMETER GROUPS

L 50 SoftPLC

#### Description:

This parameter defines the value to be added to the control setpoint in automatic mode to increase the control process variable before the Pump Genius go into sleep mode. When the control process variable reach the control setpoint value added to the sleep boost offset, the Pump Genius will go into sleep mode.



### NOTE!

This parameter is displayed according to the selection of the engineering unit 1 parameters (P0510 and P0511). A setting of "0" disable the sleep boost. This function is only enabled to use for control action of the PID controller in direct mode (P1028=1).



### NOTE!

The alarm message "A756: Sleep Boost Active" will be generated on the HMI of the CFW-11 inverter to alert that the Pump Genius is executing the sleep boost.

### P1040 – Sleep Boost Maximum Time

**Adjustable** 0 to 32767 s **Factory Setting:** 15 s

**Range:**

**Properties:**

**Access groups via HMI:** 01 PARAMETER GROUPS

L 50 SoftPLC

#### Description:

This parameter defines the maximum time that the control process variable has to reach the control setpoint value added to the sleep boost offset, i.e., the maximum time that the sleep boost will be active. If the control process variable does not reach the control setpoint value added to the sleep boost offset during this time, the Pump Genius will go into sleep mode.

The figure 3.10 presents a timing analysis of the Pump Genius operation with a direct mode PID controller when it is configured for Wake up Mode and Sleep Mode with Sleep Boost disabled.

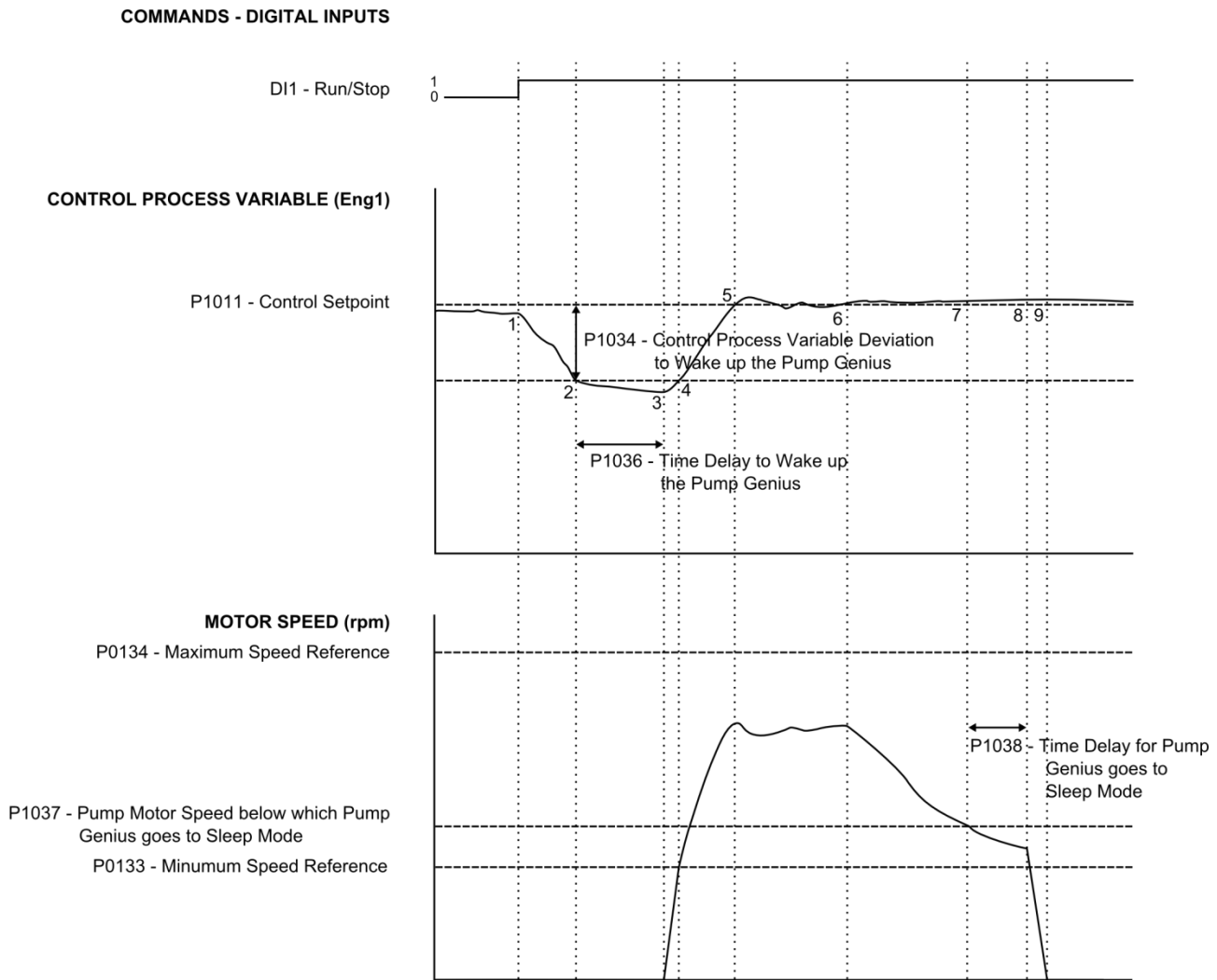

Figure 3.10 – Operation of the Pump Genius for wake up mode and sleep mode

- 1 – The Run/Stop command via digital input DI1 enables starting the motor, but also enables the operation of Pump Genius. As the condition to wake up was not detected, the pumping control remains in the sleep mode and the pump remains stopped;
- 2 – The control process variable begins to decrease and is lower than the control process variable deviation programmed to wake up the Pump Genius (P1034); in this moment the time count to wake up (P1036) is initiated;
- 3 – The control process variable remains smaller than the control process deviation to wake up the Pump Genius (P1034) and the time delay to wake up (P1036) is elapsed; at this moment the control issues the command to start the pump and resumes controlling the pumping with variable speed;
- 4 – The inverter accelerates the pump up to the minimum speed (P0133). After that, the PID controller is enabled and starts controlling the pump speed;
- 5 – The resumed Pump Genius allows the value of the control process variable to catch up with the control setpoint required by the user. The PID controller output increases during the catch-up phase, raising the pumping speed. A stable phase with constant pumping speed may follow;
- 6 – The value of the control process variable continues above the setpoint due to a decrease in demand and pump speed begins to decrease;



## Parameters Description

**7** – The pump motor speed output drops below the speed for Pump Genius goes to sleep mode threshold (P1037); the time count for Pump Genius goes to sleep mode (P1038) is initiated;

**8** – The pump motor speed remains below the speed for Pump Genius goes to sleep mode threshold (P1037) and the time delay for Pump Genius goes to sleep mode (P1038) is elapsed; at this moment the control issues the command to stop the pump;

**9** – The inverter driven pump reaches "zero" speed, and remains stopped; at this moment the Pump Genius goes into sleep mode.

The figure 3.11 presents a timing analysis of the Pump Genius operation with a Direct Mode PID controller when it is configured for Start Level Mode and Sleep Mode with Sleep Boost Disabled:

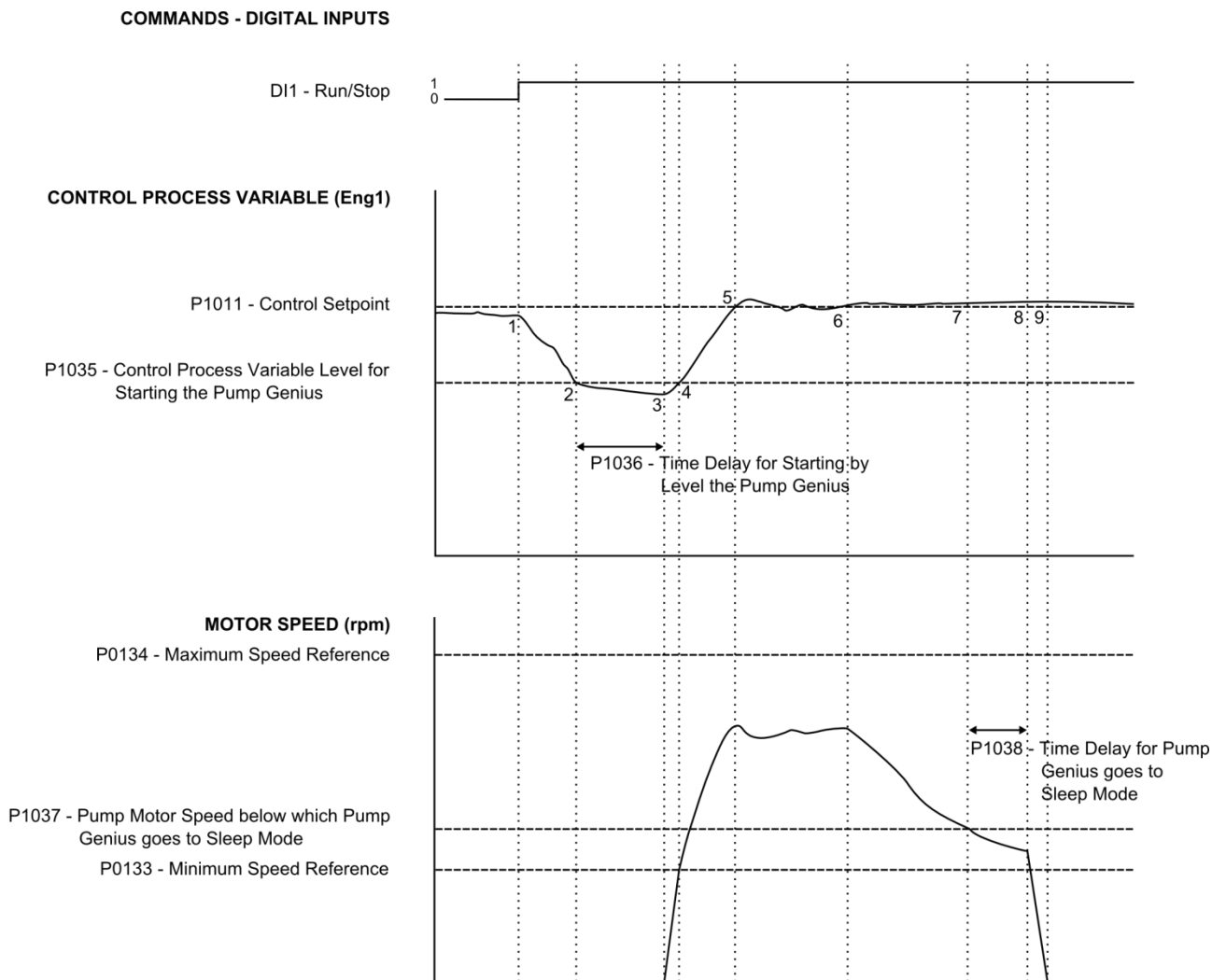

*Figure 3.11 – Operation of the Pump Genius for start level mode and sleep mode*

**1** – The Run/Stop command via digital input DI1 enables starting the motor, but also enables the operation of Pump Genius. As the control process variable level condition to start the Pump Genius was not detected, the Pump Genius remains in the sleep mode and the pump remains stopped;

**2** – The control process variable begins to decrease and is lower than the control process variable threshold programmed starting the Pump Genius (P1035); in this moment the time count for starting by level the Pump Genius (P1036) is initiated;

**3** – The control process variable remains smaller than the threshold for starting the Pump Genius (P1035) and the time delay for starting by level the Pump Genius (P1036) is elapsed; at this moment the control issues the command to start the pump and resumes controlling the pumping with variable speed;

## Parameters Description

4 – The inverter accelerates the pump up to the minimum speed (P0133). After that, the PID controller is enabled and starts controlling the pump speed;

5 – The resumed Pump Genius allows the value of the control process variable to catch up with the control setpoint required by the user. The PID controller output increases during the catch-up phase, raising the pumping speed. A stable phase with constant pumping speed may follow;

6 – The value of the control process variable continues above the setpoint due to a decrease in demand and pump speed begins to decrease;

7 – The pump motor speed output drops below the speed for Pump Genius goes to sleep mode threshold (P1037); the time count for Pump Genius goes to sleep mode (P1038) is initiated;

8 – The pump motor speed remains below the speed for Pump Genius goes to sleep mode threshold (P1037) and the time delay for Pump Genius goes to sleep mode (P1038) is elapsed; at this moment the control issues the command to stop the pump;

9 – The inverter driven pump reaches "zero" speed, and remains stopped; at this moment the Pump Genius goes into sleep mode.

The figure 3.12 presents a timing analysis of the Pump Genius operation with a Direct Mode PID controller when it is configured for Wake up Mode and Sleep Mode with Sleep Boost enabled:

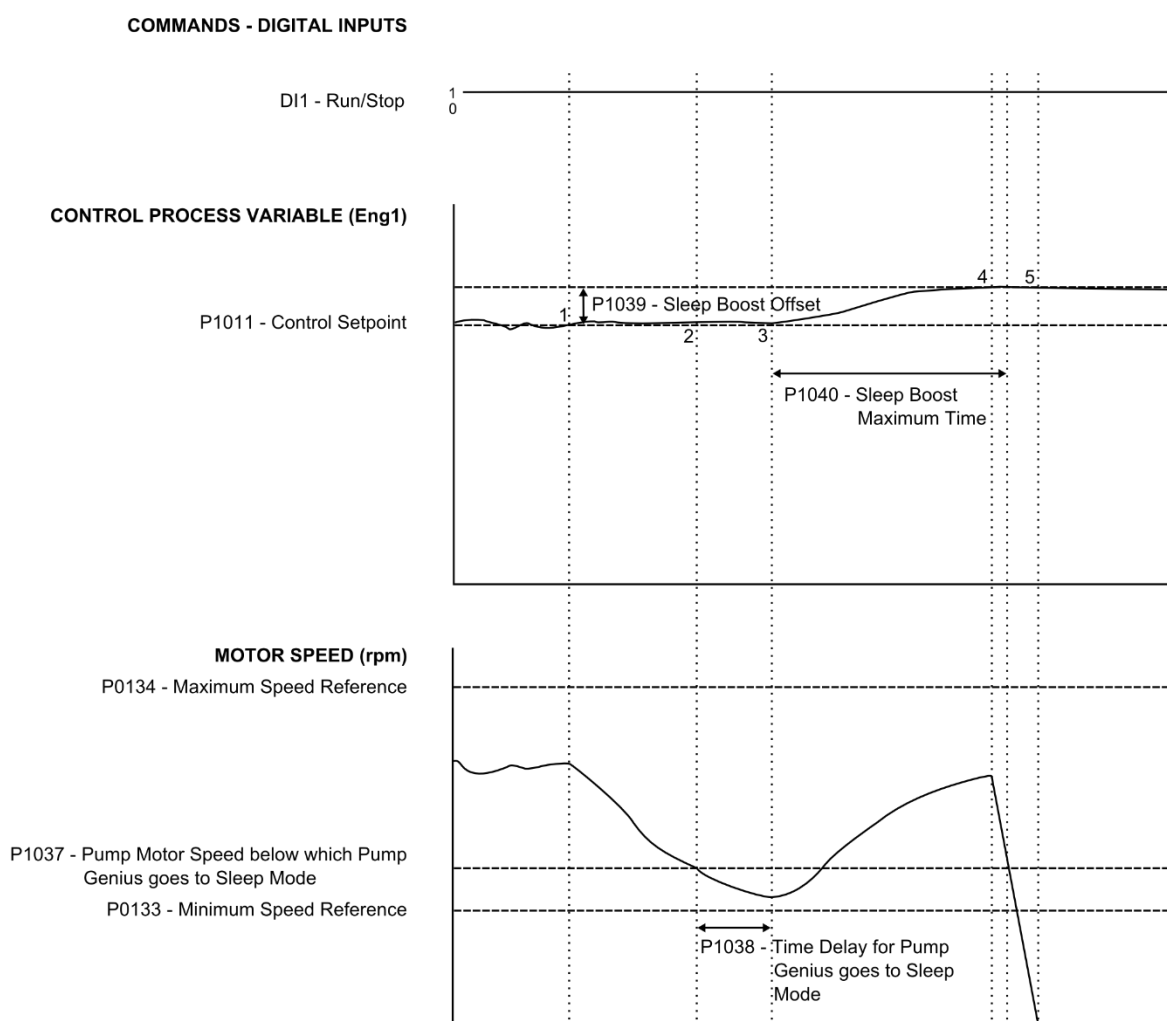

*Figure 3.12 – Operation of the Pump Genius for sleep mode with sleep boost enabled*

1 – The Pump Genius is keeping the system controlled as the control setpoint required by the user. At this moment the value of the control process variable begins to increase and the speed motor begins to decrease;

## Parameters Description

2 – The pump motor speed output drops below the speed for Pump Genius goes to sleep mode threshold (P1037); the time count for the Pump Genius go to sleep mode (P1038) is initiated;

3 – The pump motor speed remains below the speed for Pump Genius goes to sleep mode threshold (P1037) and the time delay for Pump Genius goes to sleep mode (P1038) is elapsed; at this moment, as the sleep boost is enabled will not be made the command to stop the pump. It will be added the sleep boost offset (P1039) to the control setpoint for increase the control process variable; at this moment the count of the sleep boost maximum time (P1040) is initiated;

4 – The inverter accelerates the pump again as the action of the PID controller and the control process variable reaches the control setpoint value added to the sleep boost active; at this moment the control issues the command to stop the pump before the count of the sleep boost maximum time be elapsed;

5 – The inverter driven pump reaches "zero" speed, and remains stopped; at this moment the Pump Genius goes into sleep mode.

### 3.12 PIPE CHARGING

This group of parameters allows the user to configure the Pump Genius to execute the pipe charging sequence using the pump driven by the CFW-11 inverter.

The **Pipe Charging** assures that the pumping pipe is charged gradually, thus avoiding the "water hammer" pressure shock at the instant the pipe is filled with fluid. It is executed every time the Pump Genius receives a new enable, either via enable command or an exit from a disabled by fault state. If the control process variable in the newly enabled Pump Genius is already at a certain value, and it enters into sleep mode, the pipe charging sequence is not executed.



#### NOTE!

If in enabling the Pump Genius operation (command Run/Stop active) it enters into sleep mode, the pipe charging process will not be executed.

### P0105 – Enable Pipe Charging (1<sup>st</sup>/2<sup>nd</sup> Ramp Selection)

<b>Adjustable</b>	0 = Disable (1 <sup>st</sup> Ramp)	<b>Factory Setting:</b> 6
<b>Range:</b>	6 = Enable (SoftPLC)	
<b>Properties:</b>	CFG	
<b>Access groups via HMI:</b>	01 PARAMETER GROUPS L 20 Ramps	

#### Description:

This parameter allows enabling of the pipe charging sequence (assigns to the SoftPLC function the ramp selection command) using the pump driven by CFW-11 inverter.



#### NOTE!

The alarm message "A752: Pipe Charging" will be generated in the HMI of the CFW-11 inverter providing an alert that the Pump Genius control is in the pipe charging sequence.

### P0102 – Acceleration Time 2

<b>Adjustable</b>	0.0 to 999.0 s	<b>Factory Setting:</b> 40.0 s
<b>Range:</b>		
<b>Properties:</b>		
<b>Access groups via HMI:</b>	01 PARAMETER GROUPS L 20 Ramps	

#### Description:

This parameter defines a second acceleration time for the pump driven by CFW-11 inverter for the purpose of pipe charging.

## Parameters Description



### NOTE!

Refer to the CFW-11 inverter programming manual for more information on the ramp parameters.

### P1041 – Pipe Charging Time

**Adjustable** 0 to 65535 s **Factory Setting:** 60 s

**Range:**

**Properties:**

**Access groups via HMI:** 01 PARAMETER GROUPS  
L 50 SoftPLC

#### Description:

This parameter defines the elapsed time for pipe charging.

### P1042 – Maximum Output Current during the Pipe Charging

**Adjustable** 0.0 to 3200.0 A **Factory Setting:** 0.0 A

**Range:**

**Properties:**

**Access groups via HMI:** 01 PARAMETER GROUPS  
L 50 SoftPLC

#### Description:

This parameter defines the value of the maximum motor current during the pipe charging process to execute the current limit defined by P0344.



### NOTE!

A setting of "0.0 A" executed the motor current limitation only by the value set in P0135 parameter



### NOTE!

Refer to the CFW-11 inverter programming manual for more information on the motor current limitation parameters.

The figure 3.13 presents a timing analysis of the Pump Genius operation when is configured for execution of the pipe charging sequence (the PID controller shown in this example is Direct Mode, which is, however, irrelevant for the pipe charging sequence):

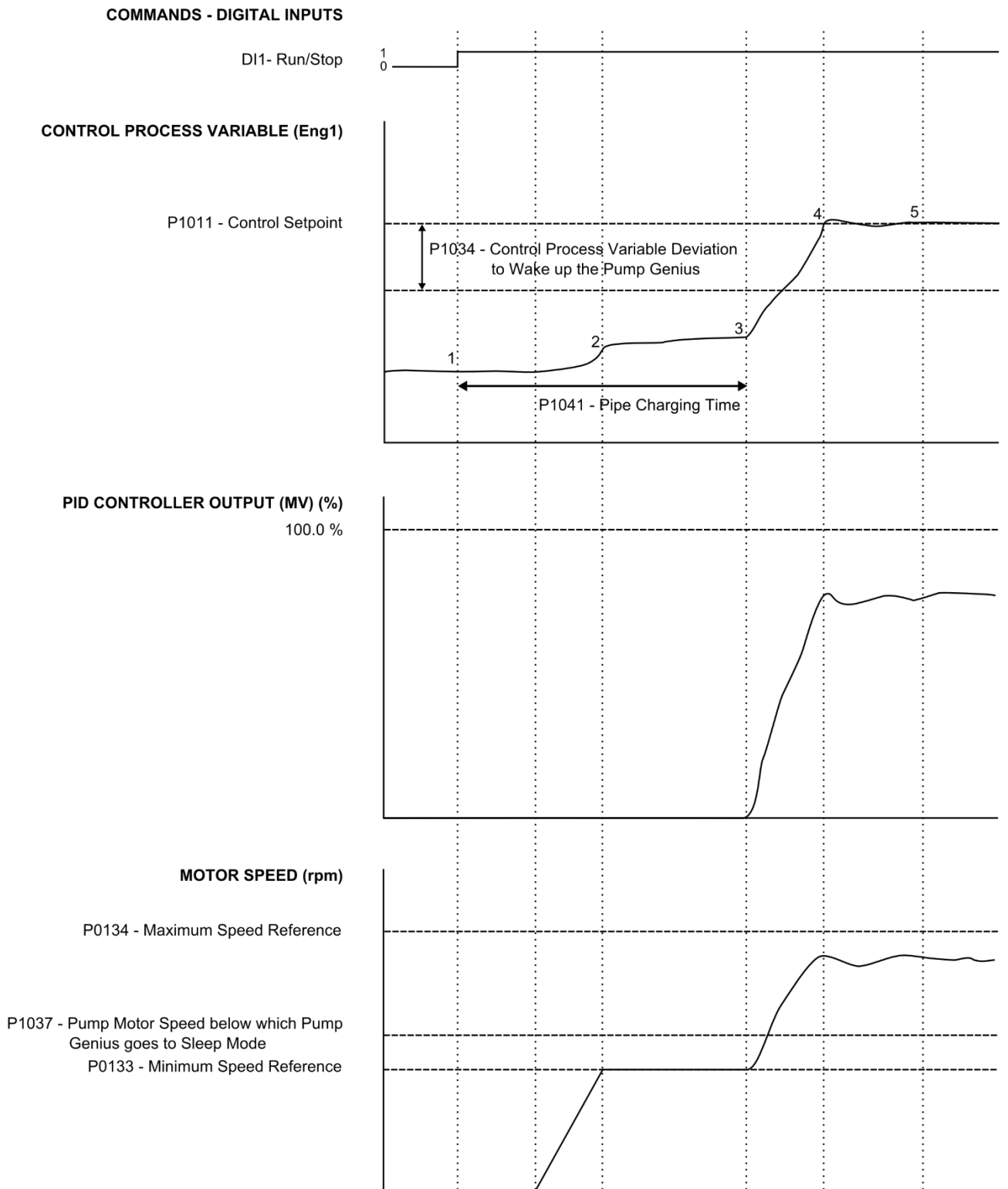

*Figure 3.13 – Operation of the Pump Genius with pipe charging enabled*

1 – The Run/Stop command via digital input DI1 enables starting the motor, but also enables the operation of Pump Genius. As the control process variable is lower than the control process deviation for Pump Genius to wake up (P1034), the time delay to wake up (P1036) is not awaited and the command run is issued. As pipe charging is enabled (P0105), the time count (P1041) is initiated, while the PID controller remains disabled. The pump is accelerated to the minimum speed (P0133) with a slower ramp in order to avoid the “water hammer”;

2 – The pump speed reaches the value programmed for minimum speed (P0133) and continues at this speed during the course of time for pipe charging (P1041). During this time the PID controller is disabled. If the value of



## P1062 – Time Delay for Starting the External Pump

<b>Adjustable</b>	0 a 32767 s	<b>Factory Setting:</b>	5 s
<b>Range:</b>			
<b>Proprieties:</b>			
<b>Access groups via HMI:</b>	01 PARAMETER GROUPS L 50 SoftPLC		

### Description:

This parameter defines the waiting time with the control process variable lower than the level for starting the external pump (P1061) to start the external pump for jockey pump function.

The figure 3.14 presents a timing analysis of the external pump for jockey pump function.

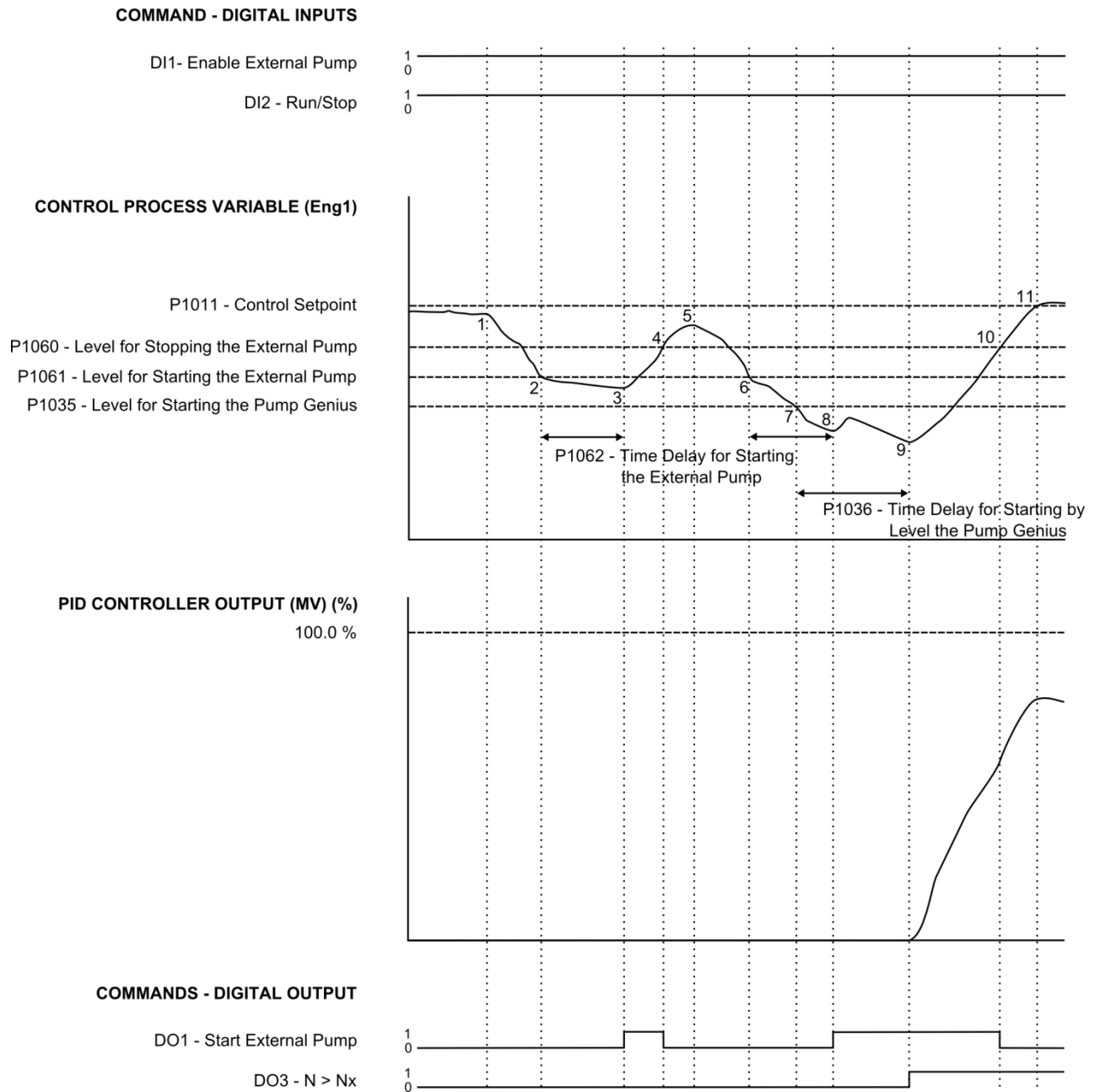

Figure 3.14 – External pump operation for jockey pump function

- 1 – The Pump Genius is enabled and in sleep mode; the control process variable begins to decrease;
- 2 – The control process variable continues to decrease and is lower than the level programmed for starting the external pump (P1061); the time count for starting the external pump (P1062) is initiated;

## Parameters Description

- 3 – The control process variable continues smaller than the level for starting the external pump (P1061) and the time delay for starting the external pump (P1062) is elapsed; in this moment is done the command to start the external pump via digital output DO1;
- 4 – With the external pump started, the control process variable is increased. The control process variable is greater than the level for stopping the external pump (P1060); in this moment is done the command to stop the external pump via digital output DO1;
- 5 – The value of the control process variable begins to decrease due to increased demand;
- 6 – The control process variable continues to decrease and is lower than the level programmed for starting the external pump (P1061); the time count for starting the external pump (P1062) is initiated;
- 7 – The control process variable continues to decrease and is lower than the level of control process variable for starting the Pump Genius (P1035); in this moment the time count for starting by level (P1036) is initiated;
- 8 – The control process variable continues smaller than the level for starting the external pump (P1061) and the time for starting the external pump (P1062) is elapsed; in this moment is done the command to start the external pump via digital output DO1;
- 9 – Even starting the external pump, the control process variable continues smaller than the level of control process variable for starting the Pump Genius (P1035) and the time for starting the Pump Genius (P1036) is elapsed; in this moment is done the run command in the CFW-11 inverter to run the pump driven by the CFW-11 inverter to control the pumping;
- 10 – The control process variable is greater than the level for stopping the external pump (P1060); in this moment is done the command to stop the external pump via digital output DO1; due to increased demand, the pump speed of the pump driven by CFW-11 inverter is increased to control the pumping as the control setpoint required by the user;
- 11 – With increasing the pump speed is achieved stabilize the control process variable as the control setpoint required by the user.

### 3.14 LOW LEVEL PROTECTION FOR THE CONTROL PROCESS VARIABLE (PIPE BREAKING)

This group of parameters allows the user to configure the conditions for alarm and failure to detect low level for the control process variable. This allows detecting non-ideal conditions of the pumping operation, for example, a pipe breaking.

#### P1024 – Value for Low Level Alarm for the Control Process Variable

<b>Adjustable Range:</b>	-32768 to 32767 [Eng. Un. 1]	<b>Factory Setting:</b>	100
<b>Properties:</b>			
<b>Access groups via HMI:</b>	<input type="text" value="01 PARAMETER GROUPS"/> <input type="text" value="L 50 SoftPLC"/>		

#### Description:

This parameter defines the value below which a low level alarm will be generated for the control process variable of the pumping control (A770).



#### NOTE!

A setting of "0" disables the low level alarm and fault for the control process variable.



#### NOTE!

This parameter is displayed according to the selection of the engineering unit 1 parameters (P0510 and P0511).



## Parameters Description

### P1025 – Time Delay for Low Level Fault for the Control Process Variable (F771)

<b>Adjustable Range:</b>	0 to 32767 s	<b>Factory Setting:</b>	0 s
<b>Properties:</b>			
<b>Access groups via HMI:</b>	<input type="text" value="01 PARAMETER GROUPS"/> <input type="text" value="L 50 SoftPLC"/>		

#### Description:

This parameter defines the waiting time with the low level alarm (A770) for the control process variable active, before the fault “F771: Low Level Fault for the Control Process Variable” is generated.



#### NOTE!

A setting of “0 s” disables the low level fault for the control process variable.

### 3.15 HIGH LEVEL PROTECTION FOR THE CONTROL PROCESS VARIABLE (PIPE OBSTRUCTION)

This group of parameters allows the user to configure the conditions for alarm and failure to detect high level for the control process variable. This allows detecting non-ideal conditions of the pumping operation, for example, a pipe obstruction.

### P1026 – Value for High Level Alarm for the Control Process Variable

<b>Adjustable Range:</b>	-32768 to 32767 [Eng. Un. 1]	<b>Factory Setting:</b>	350
<b>Properties:</b>			
<b>Access groups via HMI:</b>	<input type="text" value="01 PARAMETER GROUPS"/> <input type="text" value="L 50 SoftPLC"/>		

#### Description:

This parameter defines the value above which a high level alarm will be generated for the control process variable of the Pump Genius control (A772).



#### NOTE!

A setting of “0” disables the high level alarm and fault for the control process variable.



#### NOTE!

This parameter is displayed according to the selection of the engineering unit 1 parameters (P0510 and P0511).

### P1027 – Time Delay for High Level Fault for the Control Process Variable (F773)

<b>Adjustable Range:</b>	0 to 32767 s	<b>Factory Setting:</b>	0 s
<b>Properties:</b>			
<b>Access groups via HMI:</b>	<input type="text" value="01 PARAMETER GROUPS"/> <input type="text" value="L 50 SoftPLC"/>		

#### Description:

This parameter defines the waiting time with the high level alarm (A772) for the control process variable active, before the fault “F773: High Level Fault for the Control Process Variable” is generated.



#### NOTE!

A setting of “0 s” disables the high level fault for the control process variable.

## Parameters Description

### 3.16 DRY PUMP PROTECTION

This group of parameters allows the user to configure dry pump detection, to protect the inverter driven pump.

#### P1043 – Motor Speed for Dry Pump

<b>Adjustable Range:</b>	0 to 18000 rpm	<b>Factory Setting:</b>	1650 rpm
<b>Properties:</b>			
<b>Access groups via HMI:</b>	<input type="text" value="01 PARAMETER GROUPS"/> <input type="text" value="L 50 SoftPLC"/>		

#### Description:

This parameter defines the pump motor speed threshold value, above which evaluation of actual motor torque to detect the dry pump condition (P1044) is enabled.

#### P1044 – Motor Torque for Dry Pump

<b>Adjustable Range:</b>	0.0 to 100.0 %	<b>Factory Setting:</b>	20.0 %
<b>Properties:</b>			
<b>Access groups via HMI:</b>	<input type="text" value="01 PARAMETER GROUPS"/> <input type="text" value="L 50 SoftPLC"/>		

#### Description:

This parameter defines the pump motor torque threshold value, below which the dry pump condition is detected, resulting in the alarm message “A780: Dry Pump”.

#### P1045 – Time Delay for Dry Pump Fault (F781)

<b>Adjustable Range:</b>	0 to 32767 s	<b>Factory Setting:</b>	0 s
<b>Properties:</b>			
<b>Access groups via HMI:</b>	<input type="text" value="01 PARAMETER GROUPS"/> <input type="text" value="L 50 SoftPLC"/>		

#### Description:

This parameter defines the waiting time with the dry pump condition (A780) active, before the dry pump fault “F781: Dry Pump” is generated.



#### NOTE!

A setting of “0 s” disables the dry pump fault.

The figure 3.15 presents a timing analysis of the Pump Genius operation when a Dry Pump Fault is detected:

CONTROL PROCESS VARIABLE (Eng1)

P1011 - Control Setpoint

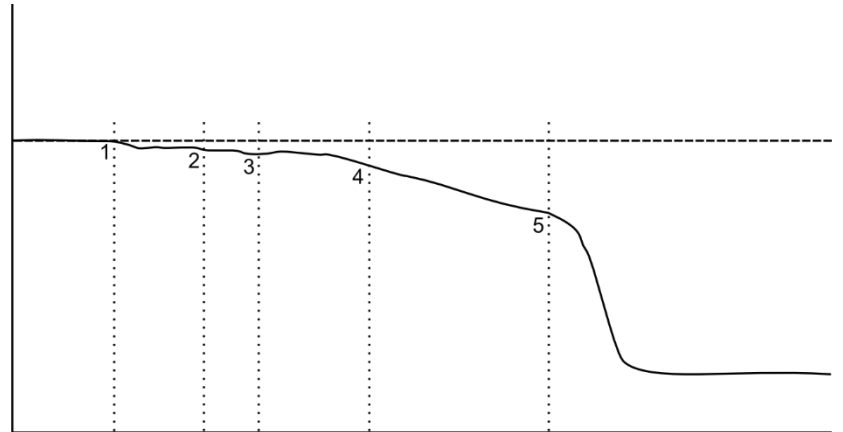

MOTOR SPEED (rpm)

P0134 - Maximum Speed Reference

P1043 - Motor Speed for Dry Pump

P0133 - Minimum Speed Reference

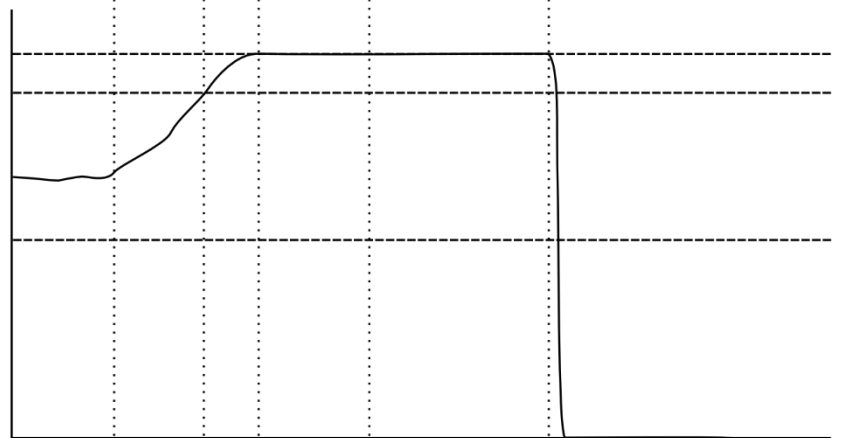

MOTOR TORQUE (%)

100.0 %

P1044 - Motor Torque for Dry Pump

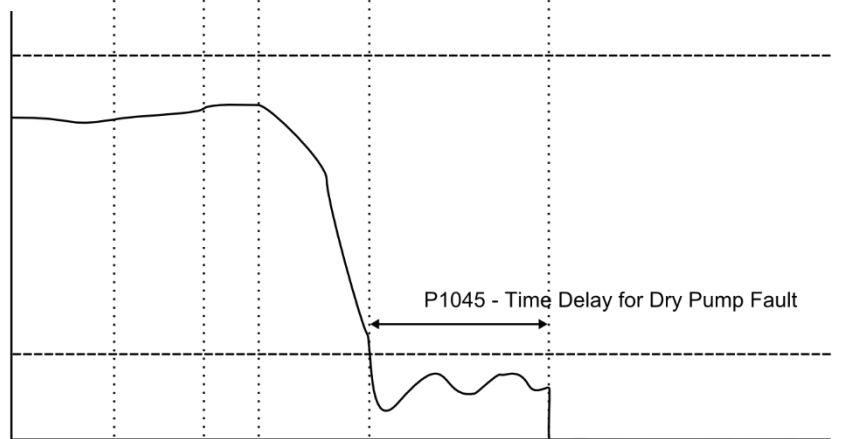

COMMANDS - DIGITAL OUTPUTS

DO1 - No Fault

1

DO2 - N > Nx

1

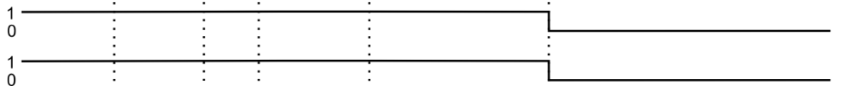

Figure 3.15 – Operation of the Pump Genius for dry pump protection

- 1 – The Pump Genius is running at a speed satisfying the control setpoint required by the user. At this moment the value of the control process variable begins to decrease and pump speed begins to increase;
- 2 – The pump speed continues to increase and becomes greater than the threshold programmed for detecting dry pump (P1043);

## Parameters Description

3 – The pump speed continues to increase and reaches the maximum speed programmed for the pump (P0134), but as the pump motor torque is still greater than the threshold programmed to detect dry pump (P1044), pumping continues while the value of the control process variable continues to decrease;

4 – As the pump continues to operate at maximum speed, and the process variable continues to decrease, the pump motor torque drops below the threshold programmed to detect dry pump (P1044). At this moment the time count to generate Dry Pump Fault (P1045) is initiated and the alarm message "A780: Dry Pump" is generated to alert the user, that the protection for dry pump is about to act and disable the inverter driven pump;

5 – The pump continues to operate at maximum speed, and the control process variable continues to decrease, while the pump motor torque remains below the threshold programmed to detect Dry Pump (P1044). At this moment the time delay to generate Dry Pump Fault (P1045) is elapsed, and the fault "F781: Dry Pump" is generated, disabling the inverter driven pump.

### 3.17 PUMP PROTECTION VIA EXTERNAL SENSOR

This group of parameters allows the user to configure an external sensor (pressure switch, level sensor, etc.) to protect the inverter driven pump. The sensor or sensors must be installed at the digital input DI6.



**NOTE!**

Enabling the use of an external sensor for pump protection is accomplished by programming the digital input DI6 in "21=External Sensor", as described in section 3.4.

### P1046 – Time Delay for Pump Protection Faults via External Sensor (F783)

**Adjustable** 0 to 32767 s **Factory Setting:** 2 s

**Range:**

**Properties:**

**Access groups via HMI:** 01 PARAMETER GROUPS  
L 50 SoftPLC

**Description:**

This parameter defines the waiting time with the condition of sensor (DI6) at logic level "0" while the pump is running, before the external sensor fault "F783: External Sensor Protection" is generated.



**NOTE!**

A setting of "0 s" disables the pump protection faults via external sensor (DI6).

### 3.18 CONTROL AUXILIARY VARIABLE FOR PUMP PROTECTION

This group of parameters allows the user to configure a control auxiliary variable for the protection of pump. This protection is accomplished by reading a sensor installed on an analog input, and comparing its value with low level conditions. The low level condition is directly associated with pump cavitation protection.

**Cavitation** is a phenomenon that occurs in a pump when the pressure at the inlet side of the rotor drops below the vapor pressure of the pumped liquid, resulting in evaporation with the formation of small vapor bubbles (cavities) in the liquid part. When these cavities, formed in the low pressure region of the rotor, reach the high pressure region at the outlet side of the rotor, they immediately collapse, returning to the liquid phase. The rapid implosion of the cavities results in violent shock waves and momentary huge temperature gradients between the bubble surface and the surrounding liquid (10000°C have been measured). If, prior to their collapse, these bubbles adhere to rotor surfaces, their implosion produces microjets, which impact the surface with sufficient energy to remove microscopic amounts of material. Immediate negative consequences of cavitation and its cumulative effects over extended periods of time are as follows:

- Operation with high level of noise and vibration;
- Impairment of performance, changing the pump characteristics;
- Premature wear of the rotor by removal of metal particles.

## Parameters Description

Occurrence of pump cavitation can be prevented by avoiding operation with insufficient liquid at the inlet of the pump. Installing an external sensor in the suction part, for example a level sensor, which measures the inlet reservoir fluid level, can help detect conditions that lead to cavitation. When this level is below a certain threshold, the control setpoint is changed to a value that reduces pump suction, thus lowering the pressure difference between the inlet and outlet of the pump.

### P1047 – Control Auxiliary Variable Selection Source for Pump Protection

**Adjustable Range:** 0 = Without Protection via Control Auxiliary Variable  
 1 = Control Auxiliary Variable via Analog Input AI1  
 2 = Control Auxiliary Variable via Analog Input AI2  
 3 = Control Auxiliary Variable via Analog Input AI3  
 4 = Control Auxiliary Variable via Analog Input AI4  
**Factory Setting:** 0

**Properties:**

**Access groups via HMI:** 01 PARAMETER GROUPS  
 L 50 SoftPLC

**Description:**

This parameter defines the source of the control auxiliary variable for pump protection.

*Table 3.9 – Description of control auxiliary variable source for pump protection*

P1045	Description
0	It defines that there is no pump protection via control auxiliary variable.
1	It defines that the source of the control auxiliary variable for pump protection is the value read by the analog input AI1. The value is converted according to engineering unit 2 and displayed in parameter P1017.
2	It defines that the source of the control auxiliary variable for pump protection is the value read by the analog input AI2. The value is converted according to engineering unit 2 and displayed in parameter P1017.
3	It defines that the source of the control auxiliary variable for pump protection is the value read by the analog input AI3. The value is converted according to engineering unit 2 and displayed in parameter P1017.
4	It defines that the source of the control auxiliary variable for pump protection is the value read by the analog input AI4. The value is converted according to engineering unit 2 and displayed in parameter P1017.

### 3.18.1 Engineering Unit Configuration

This group of parameters allows the user to configure the engineering unit of the control auxiliary variable for pump protection.

### P0512 – Engineering Unit 2

**Adjustable Range:** 0 = None  
 1 = V  
 2 = A  
 3 = rpm  
 4 = s  
 5 = ms  
 6 = N  
 7 = m  
 8 = Nm  
 9 = mA  
 10 = %  
 11 = °C  
 12 = CV  
 13 = Hz  
 14 = HP  
 15 = h  
 16 = W  
 17 = kW  
 18 = kWh  
 19 = H  
 20 = min  
 21 = °F  
**Factory Setting:** 10

## Parameters Description

22 = bar  
 23 = mbar  
 24 = psi  
 25 = Pa  
 26 = kPa  
 27 = MPa  
 28 = mwc (meter of water column)  
 29 = mca (metro de columna d'agua)  
 30 = gal  
 31 = l (litro)  
 32 = in  
 33 = ft  
 34 = m<sup>3</sup>  
 35 = ft<sup>3</sup>  
 36 = gal/s  
 37 = GPM (= gal/min)  
 38 = gal/h  
 39 = l/s  
 40 = l/min  
 41 = l/h  
 42 = m/s  
 43 = m/min  
 44 = m/h  
 45 = ft/s  
 46 = ft/min  
 47 = ft/h  
 48 = m<sup>3</sup>/s  
 49 = m<sup>3</sup>/min  
 50 = m<sup>3</sup>/h  
 51 = ft<sup>3</sup>/s  
 52 = CFM (= ft<sup>3</sup>/min)  
 53 = ft<sup>3</sup>/h  
 54 = kgf  
 55 = kgfm  
 56 = lbf  
 57 = lbfft  
 58 = ohm  
 59 = rpm/s  
 60 = mH  
 61 = ppr  
 62 = °  
 63 = rot

### Properties:

#### Access groups via HMI:

01 PARAMETER GROUPS

L 30 HMI

### Description:

This parameter selects the engineering unit that will be displayed in the SoftPLC user parameter that is associated with it. I.e., any SoftPLC user parameter that is associated with the engineering unit 2 will be displayed in this format on the CFW-11 inverter HMI.



#### NOTE!

The parameters P1017, P1048, P1049 and P1051 are associated with engineering unit 2.

## Parameters Description

### P0513 – Decimal Point of Engineering Unit 2

<b>Adjustable</b>	0 = xyzw	<b>Factory Setting:</b>	1
<b>Range:</b>	1 = xyzw.z		
	2 = xy.wz		
	3 = x.ywz		

#### Properties:

<b>Access groups via HMI:</b>	01 PARAMETER GROUPS
	└ 30 HMI

#### Description:

This parameter selects the decimal point that will be displayed in the SoftPLC user parameter that is associated with it. I.e., any SoftPLC user parameter that is associated with the decimal point of engineering unit 2 will be displayed in this format on the CFW-11 inverter HMI.



#### NOTE!

The parameters P1017, P1048, P1049 and P1051 are associated with engineering unit 2.

### 3.18.2 Sensor Scale Configuration

This group of parameters allows the user to configure the scale of the control auxiliary variable for pump protection.

### P1048 – Control Auxiliary Variable Sensor Maximum Level (Range)

<b>Adjustable</b>	0 to 32767 [Eng. Unit 2]	<b>Factory Setting:</b>	1000
-------------------	--------------------------	-------------------------	------

#### Range:

#### Properties:

<b>Access groups via HMI:</b>	01 PARAMETER GROUPS
	└ 50 SoftPLC

#### Description:

This parameter defines the maximum level (or range) of the control auxiliary variable sensor for pump protection according to its engineering unit.



#### NOTE!

The minimum level of the control auxiliary variable sensor is “0”.



#### NOTE!

This parameter is displayed according to the selection of the engineering unit 2 parameters (P0512 and P0513).

The relationship between the analog input,  $AI_x$ , configured for control auxiliary variable sensor, and the display value, P1017, in engineering units, is as follows:

$$P1017 = P1048 \times AI_x$$

Where,

P1017 = Control auxiliary variable;

P1048 = Maximum level (or range) of the control auxiliary variable sensor;

$AI_x$  = Value of analog input AI1, AI2, AI3 or AI4 in %.

## Parameters Description

### 3.18.3 Pump Protection Configuration

This group of parameters allows the user to configure the protection of pump via control auxiliary variable.

#### P1049 – Value to detect Low Level of Control Auxiliary Variable

<b>Adjustable Range:</b>	0 to 32767 [Eng. Unit 2]	<b>Factory Setting:</b>	250
<b>Properties:</b>			
<b>Access groups via HMI:</b>	<input type="text" value="01 PARAMETER GROUPS"/> <input type="text" value="L 50 SoftPLC"/>		

#### Description:

This parameter defines the control auxiliary variable threshold below which the control setpoint will be changed to the value programmed in P1050. I.e., when low level is detected, the control setpoint can be changed to a different value (lower), thus assuring a decrease in consumption of the pump, preventing it to operate in cavitation for example.



#### NOTE!

The alarm message "A774: Low Level of Control Auxiliary Variable" will be generated in the HMI of the CFW-11 inverter, to alert that the control auxiliary variable is in low level.



#### NOTE!

This parameter is displayed according to the selection of the engineering unit 2 parameters (P0512 and P0513).

#### P1050 – Control Setpoint in Low Level

<b>Adjustable Range:</b>	-32768 to 32767 [Eng. Unit 1]	<b>Factory Setting:</b>	160
<b>Properties:</b>			
<b>Access groups via HMI:</b>	<input type="text" value="01 PARAMETER GROUPS"/> <input type="text" value="L 50 SoftPLC"/>		

#### Description:

This parameter defines the value of the control setpoint in automatic mode for the Pump Genius, when a low level of the control auxiliary variable is detected.



#### NOTE!

The control setpoint should be adjusted to an appropriate value that reduces the consumption of the pump to prevent the cavitation.



#### NOTE!

This parameter is displayed according to the selection of the engineering unit 1 parameters (P0510 and P0511).

#### P1051 – Hysteresis to reactivate the Control Setpoint

<b>Adjustable Range:</b>	0 to 32767 [Eng. Unit 2]	<b>Factory Setting:</b>	100
<b>Properties:</b>			
<b>Access groups via HMI:</b>	<input type="text" value="01 PARAMETER GROUPS"/> <input type="text" value="L 50 SoftPLC"/>		



## Parameters Description

### Description:

This parameter defines the value of control auxiliary variable hysteresis to be applied for the reset of its low or high level condition, after which the Pump Genius returns to operate with the control setpoint required by the user.



#### NOTE!

This parameter is displayed according to the selection of the engineering unit 2 parameters (P0512 and P0513).

The figure 3.16 presents a timing analysis of the Pump Genius operation when low level of the control auxiliary variable is detected:

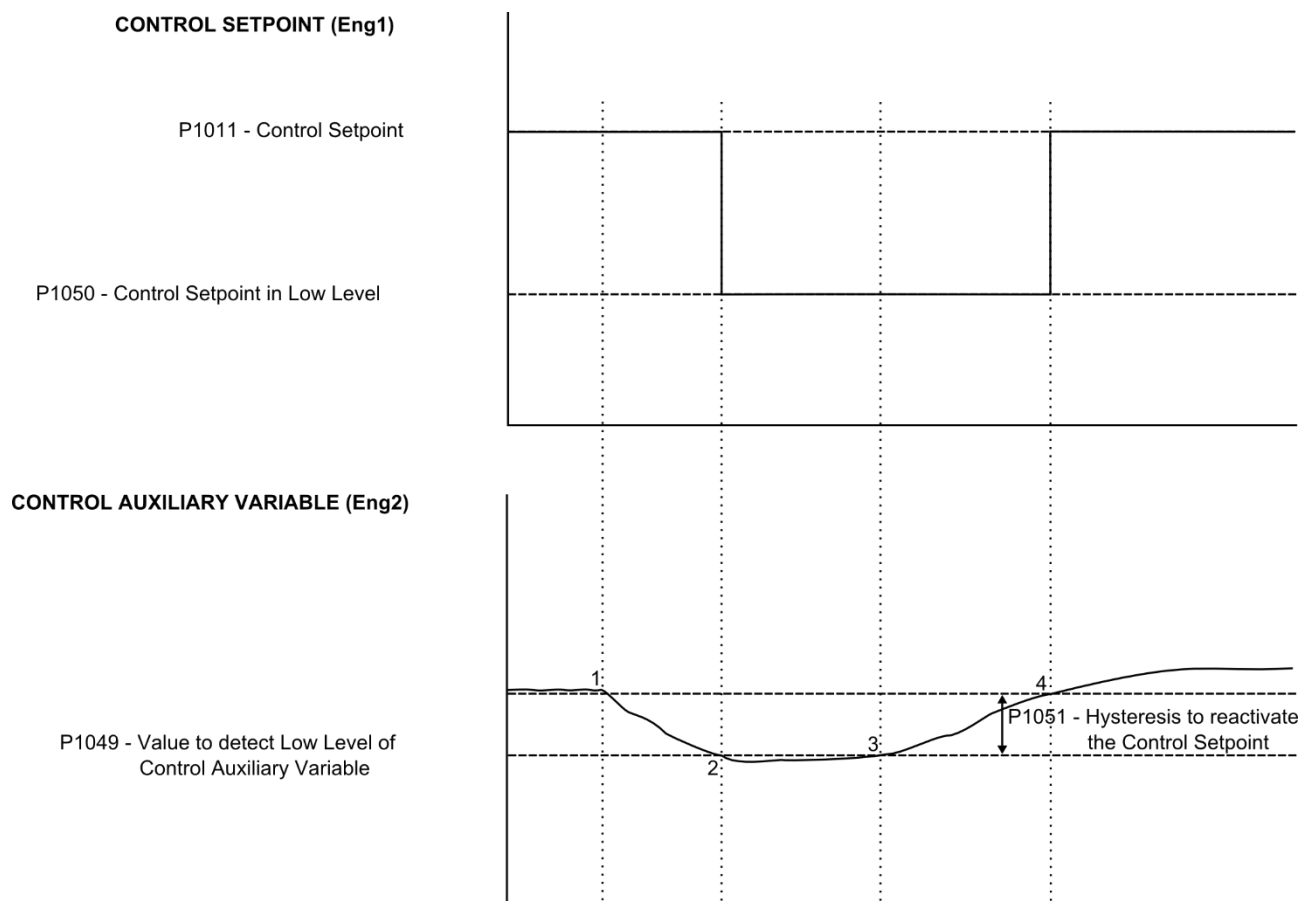

**Figure 3.16** – Pump Genius operation with pump protection via control auxiliary variable

**1** – The Pump Genius is running at a speed satisfying the control setpoint required by the user. At this moment, the value of the auxiliary variable begins to decrease;

**2** – The control auxiliary variable drops below the threshold programmed to detect low level of the control auxiliary variable (P1049). At this moment, the value of the control setpoint is changed to the value programmed as control setpoint in low level (P1050);

**3** – The change of control setpoint results in an increase of the control auxiliary variable and the same reaches the value programmed to detect low level of control auxiliary variable (P1049), but to reactivate the control setpoint is necessary to be greater than the value set in hysteresis to reactivate the control setpoint (P1051);

**4** – At this moment, its value exceeds the programmed hysteresis threshold (P1051), and the control setpoint is reset back to the value required by the user, according to the value programmed in P1011.

## Parameters Description

### 3.19 DERAGGING FUNCTION

This group of parameters allows the user to enable the logic to execute the deragging function in the inverter driven pump in order to prevent it reaches the clogging, and thus, it can't come into operation.

Its basic principle is running the pump in the reverse pumping direction to remove the accumulated debris, and thus, the pump can run again.



#### NOTE!

This function should only be enabled on a pump that can run with rotation in the reverse pumping direction; otherwise it may cause damage to it.

#### P1052 – Execution Mode of the Deragging Function

**Adjustable Range:** 0 = Not Execute Deragging Function **Factory Setting:** 0  
 1 = Executes with Command to Run the Pump  
 2 = Executes with Command via Digital Input DI2  
 3 = Executes when the Clogging of Pump is Detected

#### Properties:

**Access groups via HMI:** 01 PARAMETER GROUPS  
 L 50 SoftPLC

#### Description:

This parameter defines the execution mode of the deragging function for the pump driven by the CFW-11 inverter.

*Table 3.10 – Description of execution mode of the deragging function*

P1052	Description
0	It defines that the deragging function will not be executed, i.e., is disabled.
1	It defines that the deragging function will be enabled and executed every time there is a command to run the pump driven by CFW-11 inverter. This command can be from HMI, a digital input, via communications networks, etc.
2	It defines that the deragging function will be enabled and executed every time the digital input DI2 receives a command, i.e., change the logic level "0" to logic level "1".
3	It defines that the deragging function will be enabled and executed every time that the clogging of pump is detected via high motor current.



#### NOTE!

Order to be able execute the deragging function, it is necessary that the SoftPLC function controls the motor speed direction to do with the pump operates in reverse pumping direction. Thus, was defined that the deragging function only will operate with the CFW-11 inverter operating in REMOTE mode. Beyond that, is too necessary program the P0226 parameter in 12 (SoftPLC FWD) or in 13 (SoftPLC REV) to defines the motor speed direction in remote mode. When in 12, defines that the speed direction for pumping will be FOWARD and for deragging will be REVERSE. When in 13, defines that the speed direction for pumping will be REVERSE and for deragging will be FOWARD.

#### P1053 – Number of Cycles for Deragging

**Adjustable Range:** 0 to 100 **Factory Setting:** 5  
**Properties:**  
**Access groups via HMI:** 01 PARAMETER GROUPS  
 L 50 SoftPLC

#### Description:

This parameter defines the number of times (cycles) that the pump will operate in reverse pumping direction to execute the deragging function for the pump driven by CFW-11 inverter.

## Parameters Description

### P1054 – Speed Reference for Deragging

**Adjustable** 0 to 18000 rpm **Factory Setting:** 600 rpm

**Range:**

**Properties:**

**Access groups via HMI:** 01 PARAMETER GROUPS

L 50 SoftPLC

#### Description:

This parameter defines the speed reference value for the pump to execute the deragging function. This speed is used in the pumping direction as the deragging direction.

### P1055 – Deragging Run Time

**Adjustable** 0 to 32767 s **Factory Setting:** 10 s

**Range:**

**Properties:**

**Access groups via HMI:** 01 PARAMETER GROUPS

L 50 SoftPLC

#### Description:

This parameter defines the value of time that the pump will run (with speed reference for deragging) in the deragging cycle execution. This time is used in the pumping direction as the deragging direction.

### P1056 – Deragging Stop Time

**Adjustable** 0 to 32767 s **Factory Setting:** 10 s

**Range:**

**Properties:**

**Access groups via HMI:** 01 PARAMETER GROUPS

L 50 SoftPLC

#### Description:

This parameter defines the value of time that the pump remains stopped in the deragging cycle execution.

### P1057 – Motor Current to detect Clogging of Pump

**Adjustable** 0.0 to 3200.0 A **Factory Setting:** 20.0 A

**Range:**

**Properties:**

**Access groups via HMI:** 01 PARAMETER GROUPS

L 50 SoftPLC

#### Description:

This parameter defines the value of motor current above which will be considered that the pump is running at high current, i.e., the pump is in clogging process.

### P1058 – Time Delay to detect Clogging of Pump

**Adjustable** 0 to 32767 s **Factory Setting:** 60 s

**Range:**

**Properties:**

**Access groups via HMI:** 01 PARAMETER GROUPS

L 50 SoftPLC

#### Description:

This parameter define the waiting time with the condition of high current in the pump motor to detect that it is in clogging process, being thus generated the alarm message “A790: Clogging Detected” to indicate this situation.

## Parameters Description

### P1059 – Number of consecutives Clogging to generate the Fault (F791)

<b>Adjustable Range:</b>	0 to 100	<b>Factory Setting:</b>	5
<b>Properties:</b>			
<b>Access groups via HMI:</b>	<div style="border: 1px solid black; padding: 2px; display: inline-block;">01 PARAMETER GROUPS</div> <div style="border: 1px solid black; padding: 2px; display: inline-block;">L 50 SoftPLC</div>		

#### Description:

This parameter defines the number of consecutives clogging detected to generate the fault “F791: Excess of Clogging Detected”.



#### NOTE!

A setting of “0” disables the fault by excess of clogging detected. Every time that the Pump Genius is disabled or goes to sleep mode, i.e., the pump is stopped, the count of clogging is reset.

### 3.19.1 Deragging with Command to Run the Pump (P1052=1)

Selecting the execution mode of the deragging function (P1052) in 1 is defined that the deragging is enabled and it is executed every time there is a command to run the pump. This command can be from HMI, a digital input, via communications networks, etc.

The figure 3.17 presents a timing analysis of the deragging function operation when occurs a command to run the pump driven by the CFW-11 inverter.

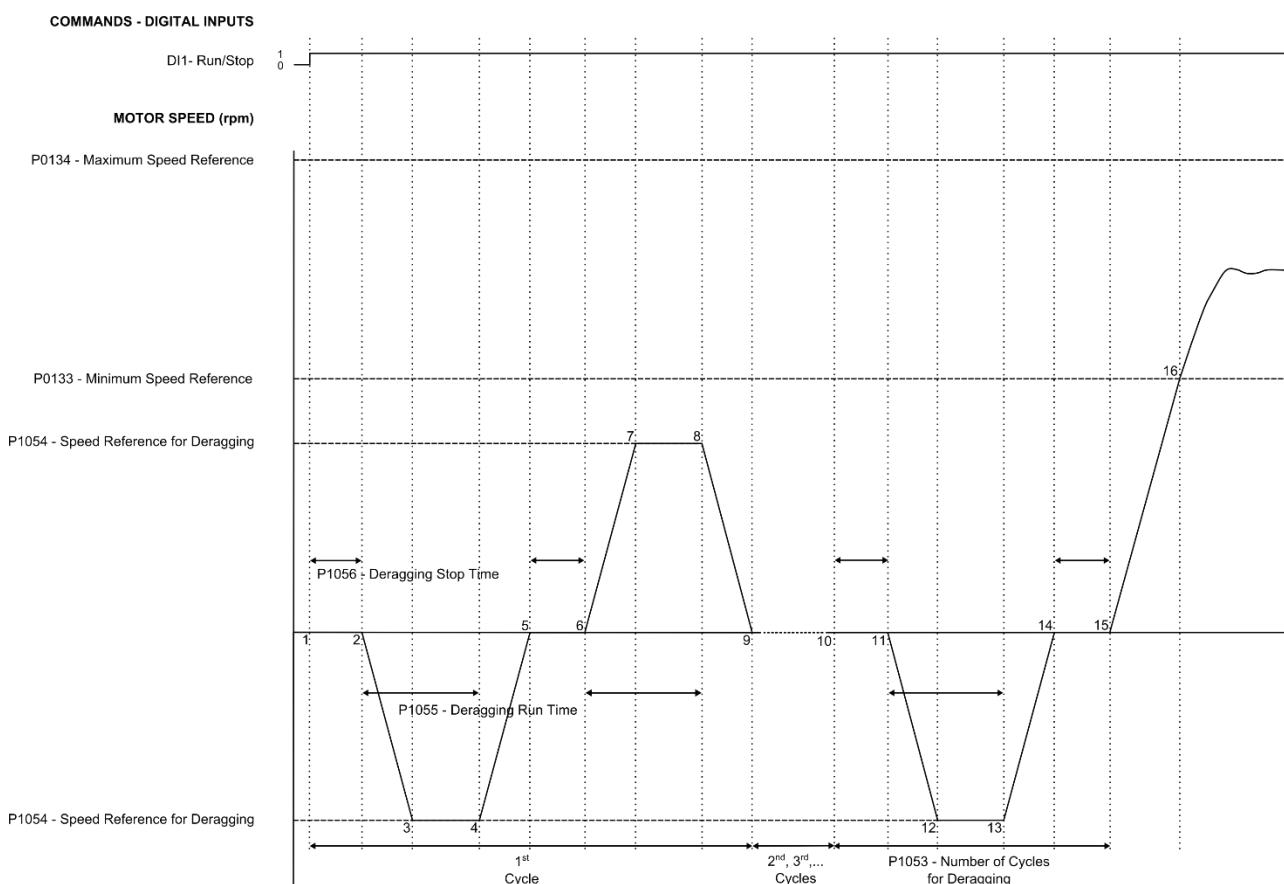

Figure 3.17 – Deragging pump operation with command to run the pump

1 – The command Run/Stop via digital input DI1 enables run the motor, as well as, enable the operation of Pump Genius. In this moment, initiate the count of the first cycle to deragging the pump and the counting time of pump stopped (P1056) is initiated;

## Parameters Description

- 2 – The deragging stop time (P1056) is elapsed; in this moment is done the command to run the pump in the reverse direction of the pumping and with the speed reference to deragging (P1054); the PID controller stays disabled. In this moment the counting time of pump running (P1055) is initiated;
- 3 – The pump is accelerated until the speed reference for deragging (P1054) with the acceleration ramp set in P0100 parameter and stays in this speed until that the counting time of pump running (P1055) is elapsed;
- 4 – The deragging run time (P1055) is elapsed; in this moment is done the command to stop the pump in reverse direction of the pumping;
- 5 – The pump is decelerated to the zero speed as the deceleration ramp set in the P0101 parameter and stays stopped. In this moment the counting time of pump stopped (P1056) is initiated;
- 6 – The deragging stop time (P1056) is elapsed; in this moment is done the command to run the pump in the direction of the pumping and with the speed reference to deragging (P1054); the PID controller stays disabled. In this moment the counting time of pump running (P1055) is initiated;
- 7 – The pump is accelerated until the speed reference for deragging (P1054) with the acceleration ramp set in P0100 parameter and stays in this speed until that the counting time of pump running (P1055) is elapsed;
- 8 – The deragging run time (P1055) is elapsed; in this moment is done the command to stop the pump in direction of the pumping;
- 9 – The pump is decelerated to the zero speed as the deceleration ramp set in the P0101 parameter and stays stopped. In this moment the counter of cycles is increased and the counting time of pump stopped (P1056) is initiated; the steps 2 to 9 occur again until that the number of cycles is equal to the number of cycles for deragging (P1053);
- 10 – The number of cycles arrives to the number of cycles for deragging (P1053) programmed and the last cycle is initiated; thus, the deragging stop time (P1056) is initiated;
- 11 – The deragging stop time (P1056) is elapsed; in this moment is done the command to run the pump in the reverse direction of the pumping and with the speed reference to deragging (P1054); the PID controller stays disabled. In this moment the counting time of pump running (P1055) is initiated
- 12 – The pump is accelerated until the speed reference for deragging (P1054) with the acceleration ramp set in P0100 parameter and stays in this speed until that the counting time of pump running (P1055) is elapsed;
- 13 – The deragging run time (P1055) is elapsed; in this moment is done the command to stop the pump in reverse direction of the pumping;
- 14 – The pump is decelerated to the zero speed as the deceleration ramp set in the P0101 parameter and stays stopped. In this moment the counting time of pump stopped (P1056) is initiated
- 15 – The deragging stop time (P1056) is elapsed; in this moment is done the command to run the pump and control the pumping again, i.e., the deragging function was finished;
- 16 – The pump is accelerated until the minimum speed reference. After this the PID controller is enabled and starts to control the pump speed in order for the control process variable to catch up with the control setpoint required by the user.

### 3.19.2 Deragging with Command via Digital Input DI2 (P1052=2)

Selecting the execution mode of the deragging function (P1052) in 2 is defined that the deragging is enabled and it is executed every time there is a command via digital input DI2, i.e., the digital input DI2 change the logic level “0” to logic level “1”.

The figure 3.18 presents a timing analysis of the deragging function operation when occurs a command in the digital input DI2.

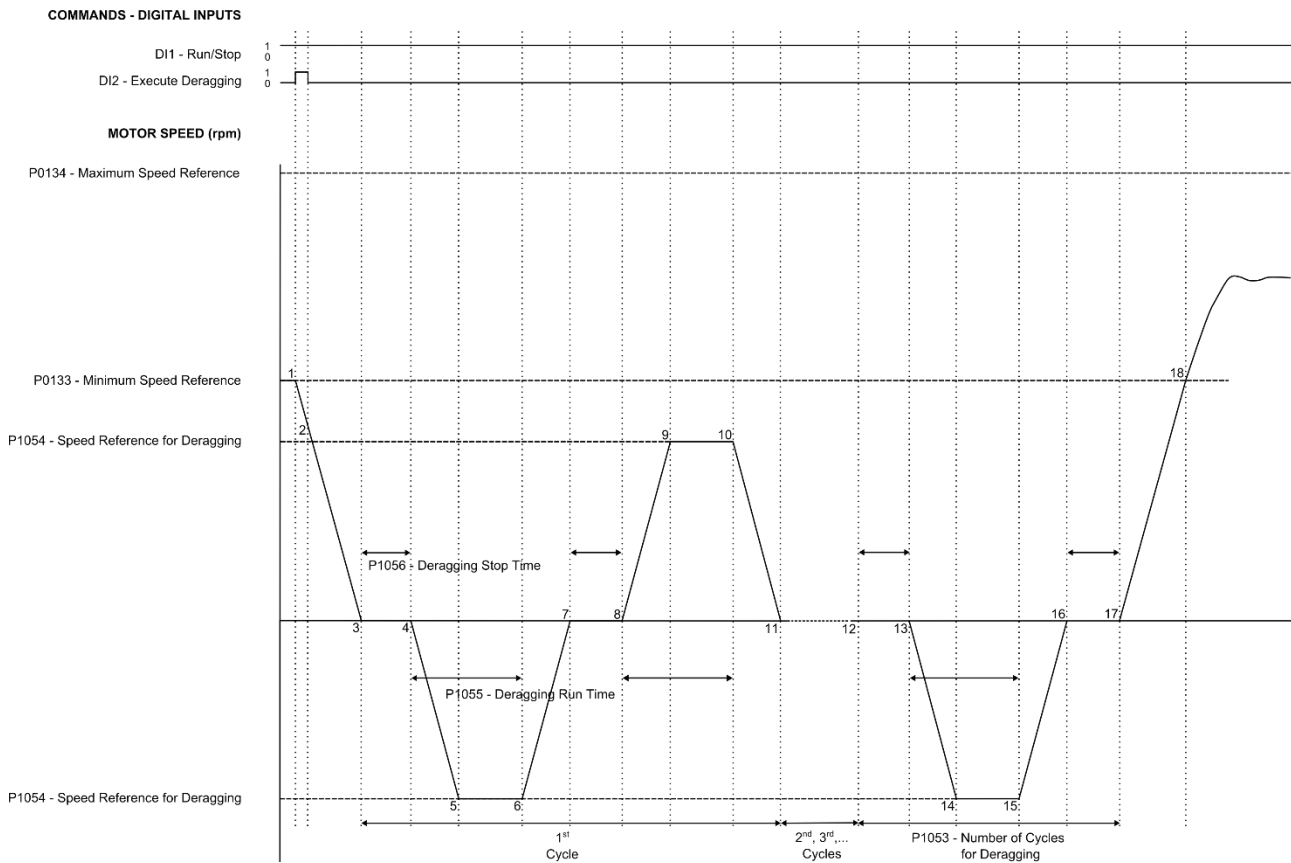

**Figure 3.18** – Deragging pump operation with command via digital input DI2

1 – The Pump Genius is enabled to run through the command Run/Stop via digital input DI1 and is controlling the pump driven by the CFW-11 inverter. In this moment, a command is done in the digital input DI2 to execute the deragging function, i.e., the digital input DI2 goes from logic level "0" to logic level "1". So, it is done the command to stop the pump and starts the deragging function;

2 – The digital input DI2 goes to logic level "0", because the command to execute the deragging function is done when the pump change the logic level of "0" to "1", i.e., when execute a pulse in the digital input DI2. The pump continues in deceleration process;

3 – The pump is decelerated to the zero speed as the deceleration ramp set in the P0101 parameter and stays stopped. In this moment initiate the count of the first cycle to deragging the pump and the counting time of pump stopped (P1056) is initiated;

4 – The deragging stop time (P1056) is elapsed; in this moment is done the command to run the pump in the reverse direction of the pumping and with the speed reference to deragging (P1054); the PID controller stays disabled. In this moment the counting time of pump running (P1055) is initiated;

5 – The pump is accelerated until the speed reference for deragging (P1054) with the acceleration ramp set in P0100 parameter and stays in this speed until that the counting time of pump running (P1055) is elapsed;

6 – The deragging run time (P1055) is elapsed; in this moment is done the command to stop the pump in reverse direction of the pumping;

7 – The pump is decelerated to the zero speed as the deceleration ramp set in the P0101 parameter and stays stopped. In this moment the counting time of pump stopped (P1056) is initiated;

8 – The deragging stop time (P1056) is elapsed; in this moment is done the command to run the pump in the direction of the pumping and with the speed reference to deragging (P1054); the PID controller stays disabled. In this moment the counting time of pump running (P1055) is initiated;

9 – The pump is accelerated until the speed reference for deragging (P1054) with the acceleration ramp set in P0100 parameter and stays in this speed until that the counting time of pump running (P1055) is elapsed;

## Parameters Description

**10** – The deragging run time (P1055) is elapsed; in this moment is done the command to stop the pump in direction of the pumping;

**11** – The pump is decelerated to the zero speed as the deceleration ramp set in the P0101 parameter and stays stopped. In this moment the counter of cycles is increased and the counting time of pump stopped (P1056) is initiated; the steps 2 to 9 occur again until that the number of cycles is equal to the number of cycles for deragging (P1053);

**12** – The number of cycles arrives to the number of cycles for deragging (P1053) programmed and the last cycle is initiated; thus, the deragging stop time (P1056) is initiated;

**13** – The deragging stop time (P1056) is elapsed; in this moment is done the command to run the pump in the reverse direction of the pumping and with the speed reference to deragging (P1054); the PID controller stays disabled. In this moment the counting time of pump running (P1055) is initiated

**14** – The pump is accelerated until the speed reference for deragging (P1054) with the acceleration ramp set in P0100 parameter and stays in this speed until that the counting time of pump running (P1055) is elapsed;

**15** – The deragging run time (P1055) is elapsed; in this moment is done the command to stop the pump in reverse direction of the pumping;

**16** – The pump is decelerated to the zero speed as the deceleration ramp set in the P0101 parameter and stays stopped. In this moment the counting time of pump stopped (P1056) is initiated

**17** – The deragging stop time (P1056) is elapsed; in this moment is done the command to run the pump and control the pumping again, i.e., the deragging function was finished;

**18** – The pump is accelerated until the minimum speed reference. After this the PID controller is enabled and starts to control the pump speed in order for the control process variable to catch up with the control setpoint required by the user.

### 3.19.3 Deragging when Clogging of Pump is detected (P1052=3)

Selecting the execution mode of the deragging function (P1052) in 3 is defined that the deragging is enabled and it is executed when the clogging of pump is detected.

The figure 3.19 presents a timing analysis of the deragging function operation when occurs a clogging of pump.

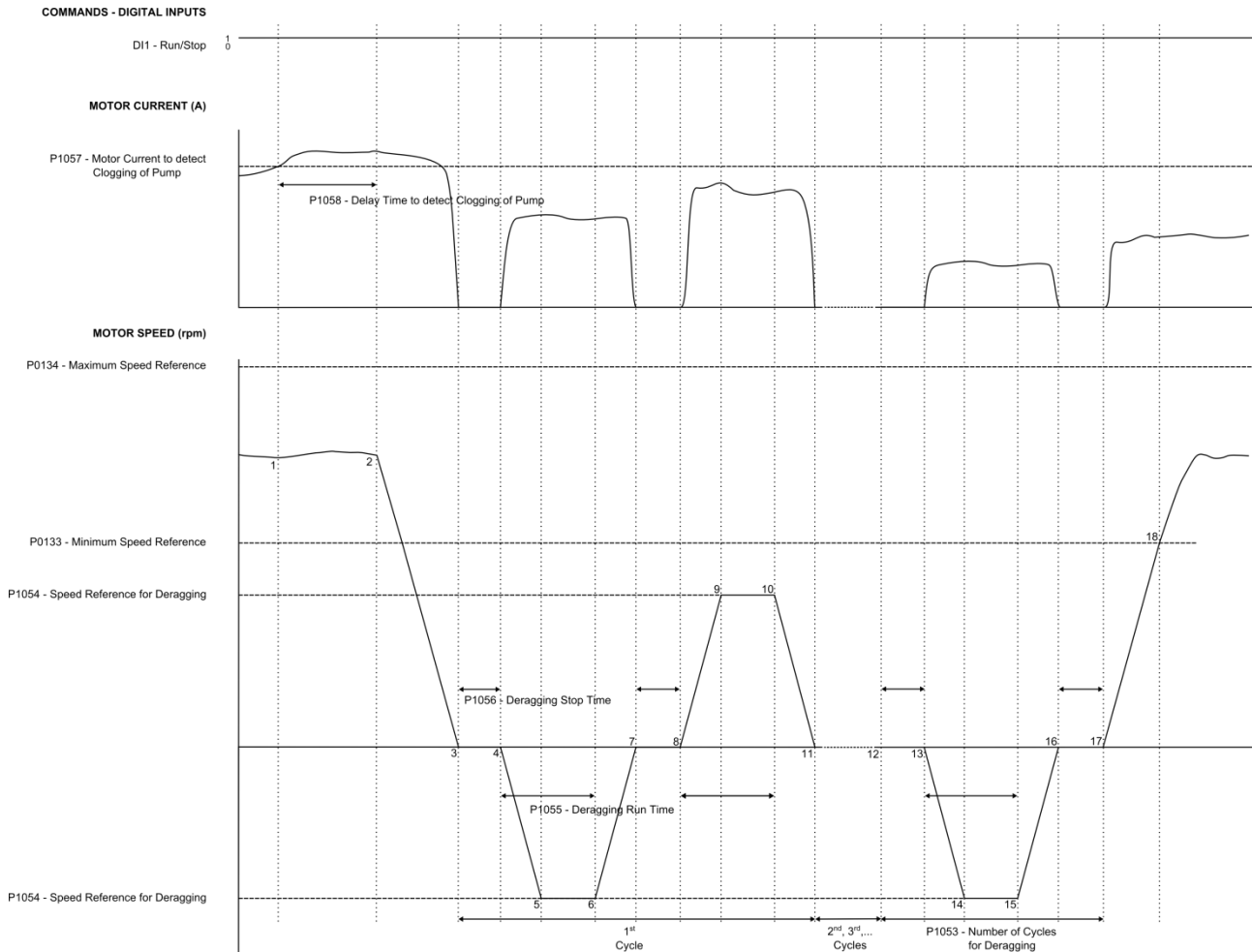

**Figure 3.19** – Deragging pump operation when a clogging of pump is detected

- 1 – The Pump Genius is enabled to run through the command Run/Stop via digital input DI1 and is controlling the pump driven by the CFW-11 inverter. In this moment the motor current is greater than the motor current to detect clogging of pump (P1057) and the counting time to detect clogging of pump (P1058) is initiated;
- 2 – The motor current remains greater than the motor current to detect clogging of pump (P1057) and the time to detect clogging of pump (P1058) is elapsed; in this moment is done the command to stop the pump and starts the deragging function;
- 3 – The pump is decelerated to the zero speed as the deceleration ramp set in the P0101 parameter and stays stopped. In this moment, initiate the count of the first cycle to deragging the pump and the counting time of pump stopped (P1056) is initiated;
- 4 – The deragging stop time (P1056) is elapsed; in this moment is done the command to run the pump in the reverse direction of the pumping and with the speed reference to deragging (P1054); the PID controller stays disabled. In this moment the counting time of pump running (P1055) is initiated;
- 5 – The pump is accelerated until the speed reference for deragging (P1054) with the acceleration ramp set in P0100 parameter and stays in this speed until that the counting time of pump running (P1055) is elapsed;
- 6 – The deragging run time (P1055) is elapsed; in this moment is done the command to stop the pump in reverse direction of the pumping;
- 7 – The pump is decelerated to the zero speed as the deceleration ramp set in the P0101 parameter and stays stopped. In this moment the counting time of pump stopped (P1056) is initiated;



## Parameters Description

**8** – The deragging stop time (P1056) is elapsed; in this moment is done the command to run the pump in the direction of the pumping and with the speed reference to deragging (P1054); the PID controller stays disabled. In this moment the counting time of pump running (P1055) is initiated;

**9** – The pump is accelerated until the speed reference for deragging (P1054) with the acceleration ramp set in P0100 parameter and stays in this speed until that the counting time of pump running (P1055) is elapsed;

**10** – The deragging run time (P1055) is elapsed; in this moment is done the command to stop the pump in direction of the pumping;

**11** – The pump is decelerated to the zero speed as the deceleration ramp set in the P0101 parameter and stays stopped. In this moment the counter of cycles is increased and the counting time of pump stopped (P1056) is initiated; the steps 2 to 9 occur again until that the number of cycles is equal to the number of cycles for deragging (P1053);

**12** – The number of cycles arrives to the number of cycles for deragging (P1053) programmed and the last cycle is initiated; thus, the deragging stop time (P1056) is initiated;

**13** – The deragging stop time (P1056) is elapsed; in this moment is done the command to run the pump in the reverse direction of the pumping and with the speed reference to deragging (P1054); the PID controller stays disabled. In this moment the counting time of pump running (P1055) is initiated

**14** – The pump is accelerated until the speed reference for deragging (P1054) with the acceleration ramp set in P0100 parameter and stays in this speed until that the counting time of pump running (P1055) is elapsed;

**15** – The deragging run time (P1055) is elapsed; in this moment is done the command to stop the pump in reverse direction of the pumping;

**16** – The pump is decelerated to the zero speed as the deceleration ramp set in the P0101 parameter and stays stopped. In this moment the counting time of pump stopped (P1056) is initiated

**17** – The deragging stop time (P1056) is elapsed; in this moment is done the command to run the pump and control the pumping again, i.e., the deragging function was finished;

**18** – The pump is accelerated until the minimum speed reference. After this the PID controller is enabled and starts to control the pump speed in order for the control process variable to catch up with the control setpoint required by the user.

### 3.20 HMI MONITORING

This parameter group allows the user to configure which parameters will be shown on the HMI display in the monitoring mode.

#### P0205 – Reading Parameter Selection 1

#### P0206 – Reading Parameter Selection 2

#### P0207 – Reading Parameter Selection 3



#### NOTE!

Refer to the CFW-11 programming manual for more information about the HMI parameters. Some parameter options have been removed from the configuration wizard.

## Parameters Description

### 3.21 READING PARAMETERS

#### P1010 – Pump Genius Simplex Application Version

<b>Adjustable</b>	0.00 to 10.00	<b>Factory Setting:</b>	-
<b>Range:</b>			
<b>Properties:</b>	RO		
<b>Access groups via HMI:</b>	01 PARAMETER GROUPS L 50 SoftPLC		

#### Description:

This parameter indicates the version of the Pump Genius Simplex application.

#### P1016 – Control Process Variable

<b>Adjustable</b>	-32768 to 32767 [Eng. Un. 1]	<b>Factory Setting:</b>	-
<b>Range:</b>			
<b>Properties:</b>	RO		
<b>Access groups via HMI:</b>	01 PARAMETER GROUPS L 50 SoftPLC		

#### Description:

This parameter indicates the value of the Pump Genius control process variable according to the source of the control process variable selected by P1021.



#### NOTE!

This parameter is displayed according to the selection of the engineering unit 1 parameters (P0510 and P0511).

#### P1017 – Control Auxiliary Variable

<b>Adjustable</b>	0 to 32767 [Eng. Un. 2]	<b>Factory Setting:</b>	-
<b>Range:</b>			
<b>Properties:</b>	RO		
<b>Access groups via HMI:</b>	01 PARAMETER GROUPS L 50 SoftPLC		

#### Description:

This parameter indicates the value of the Pump Genius control auxiliary variable according to the source of the control auxiliary variable selected by P1047.



#### NOTE!

This parameter is displayed according to the selection of the engineering unit 2 parameters (P0512 and P0513).

#### P1019 – Pump Genius Simplex Logical Status

<b>Adjustable</b>	0000h to FFFFh	<b>Factory Setting:</b>	-
<b>Range:</b>			
<b>Properties:</b>	RO		
<b>Access groups via HMI:</b>	01 PARAMETER GROUPS L 50 SoftPLC		

#### Description:

This parameter allows the monitoring of the Pump Genius Simplex application status. Each bit corresponds to one state.

## Parameters Description

*Table 3.11 – Description of Pump Genius Simplex status word*

Bits	15	14	13	12	11	10	9	8	7	6	5	4	3	2	1	0
Function	Excess of Clogging (F791)	Pump Clogging detected (A790)	Deragging in Execution (A794)	External Pump Running	External Sensor Protection (F873)	External Sensor Protection (A872)	Dry Pump (F781)	Dry Pump (A780)	Low Level Auxiliary Variable (A774)	High Level Process Variable (F773)	High Level Process Variable (A772)	Low Level Process Variable (F771)	Low Level Process Variable (A770)	Sleep Boost Active (A756)	Pipe Charging (A752)	Sleep Mode Active (A750)

Bits	Values
Bit 0 Sleep Mode Active (A750)	0: No alarm indication. 1: It indicates that the Pump Genius is in the sleep mode (A750).
Bit 1 Pipe Charging (A752)	0: No alarm indication. 1: It indicates that the process of pipe charging is being executed (A752).
Bit 2 Sleep Boost Active (A756)	0: No alarm indication. 1: It indicates that the Pump Genius is executing the Sleep Boost before to sleep (A756).
Bit 3 Low Level Process Variable (A770)	0: No alarm indication. 1: It indicates that the control process variable (P1016) is in low level (A770).
Bit 4 Low Level Process Variable (F771)	0: No fault indication. 1: It indicates that the Pump Genius was stopped due to low level of the control process variable (F771).
Bit 5 High Level Process Variable (A772)	0: No alarm indication. 1: It indicates that the control process variable (P1016) is in high level (A772).
Bit 6 High Level Process Variable (F773)	0: No fault indication. 1: It indicates that the Pump Genius was stopped due to high level of the control process variable (F773).
Bit 7 Low Level Auxiliary Variable (A774)	0: No alarm indication. 1: It indicates that the control auxiliary variable (P1017) is in low level and the control setpoint was changed to the value of P1048 (A774).
Bit 8 Dry Pump (A780)	0: No alarm indication. 1: It indicates that the dry pump condition was detected (A780).
Bit 9 Dry Pump (F781)	0: No fault indication. 1: It indicates that the pump was stopped due to dry pump protection (F781).
Bit 10 External Sensor Protection (A782)	0: No alarm indication. 1: It indicates that protection via external sensor (DI6) is actuated (A782).
Bit 11 External Sensor Protection (F783)	0: No fault indication. 1: It indicates that the pump was stopped due to protection via external sensor (DI6) (F783).
Bit 12 External Pump Running	0: It indicates that the external pump is stopped or is not enabled. 1: It indicates that the external pump is running.
Bit 14 Deragging in Execution (A794)	0: No alarm indication. 1: It indicates that the deragging process is in execution (A794).
Bit 14 Pump Clogging detected (A790)	0: No alarm indication. 1: It indicates it has detected clogging the pump to operate with high current (A790).
Bit 15 Excess of Clogging (F791)	0: No fault indication. 1: It indicates that the pump was stopped due an excessive number of clogging detected (F791).

## Creation And Download the Application

### 4 CREATION AND DOWNLOAD THE APPLICATION

In order to configure the CFW-11 inverter for Pump Genius Simplex application, it is necessary to create the ladder application on the WLP and then download it to the SoftPLC function of the CFW-11 inverter, as well as the parameter values configured on the configuration wizard.

The following steps show how to create and configure the Pump Genius Simplex application in the WLP and how to transfer it to the CFW-11 inverter.



#### NOTE!

The Pump Genius Simplex application only works on CFW-11 inverter with **especial firmware version Ve.5.3x**. So upgrading the CFW-11 inverter firmware to the working of this application is required.

**1<sup>st</sup> Step:** Create a new project on the WLP based on the Pump Genius Simplex ladder standard application. For this, select Tools, Application, CFW-11, Create, Pump Genius and finally click Simplex;

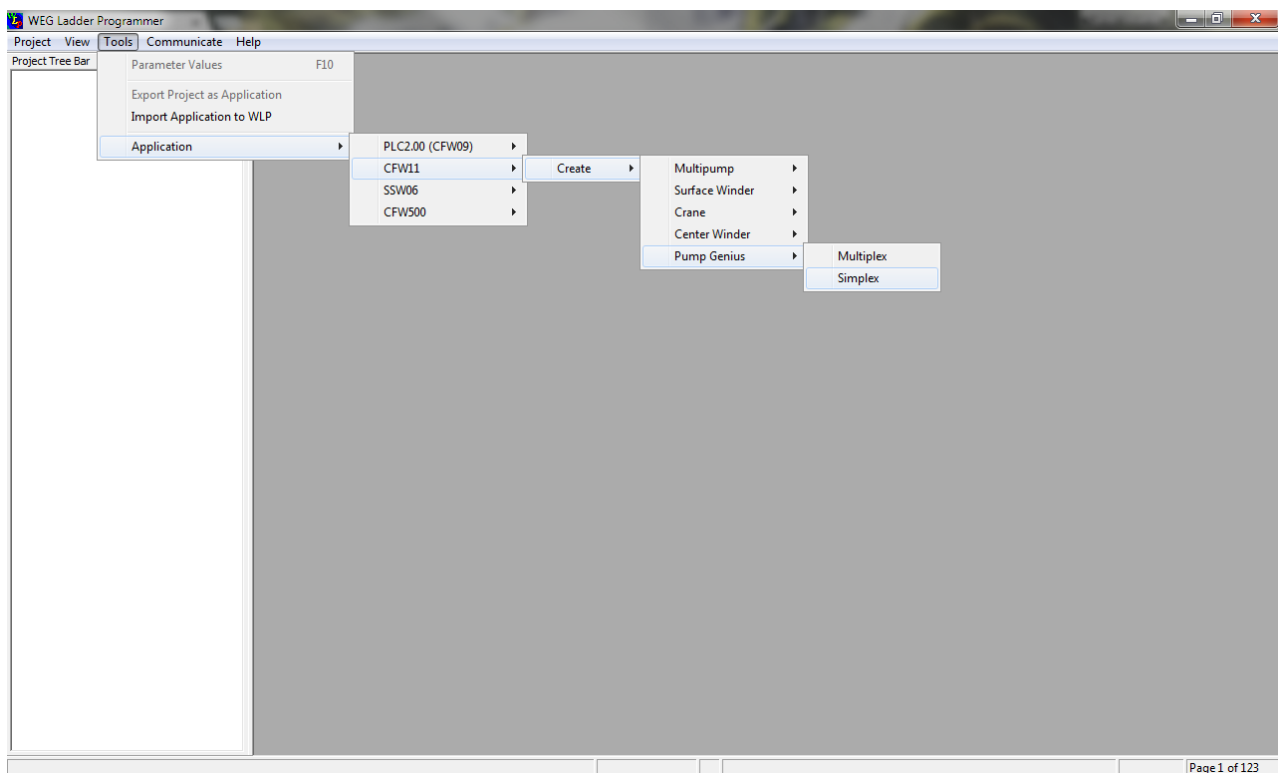

*Figure 4.1 – Create the Pump Genius Simplex application in the WLP*

**2<sup>nd</sup> Step:** Name the new project created;

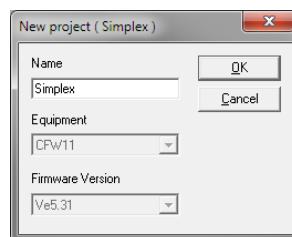

*Figure 4.2 – Dialog to name the new project*

## Creation And Download the Application

**3<sup>rd</sup> Step:** Adjust the configuration of the WLP communication interface with the equipment, can be via serial port (COM1..COM8) or via USB. For this, select Communicate and then click Configuration (Shift + F8);

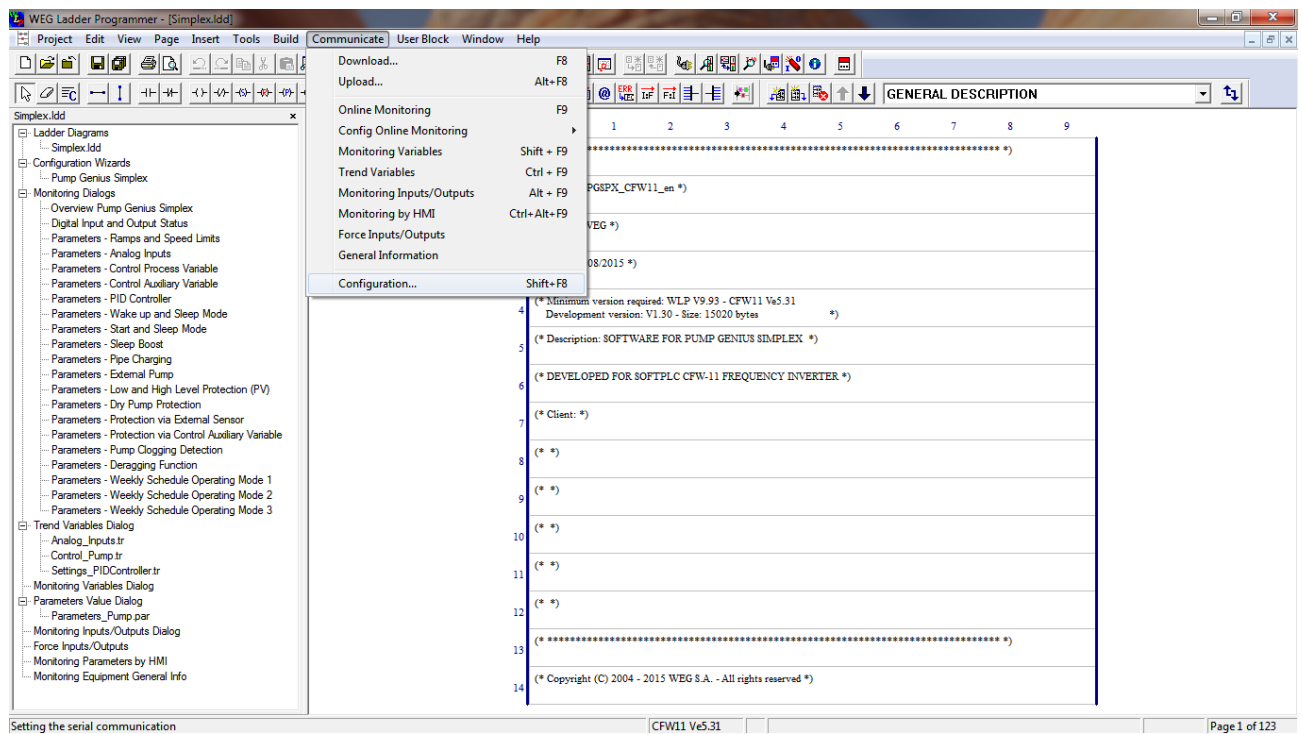

*Figure 4.3 – Adjust the communication interface in the new project*

**4<sup>th</sup> Step:** Download the ladder application and user's parameter. For this, select Communicate and then click Download (F8);

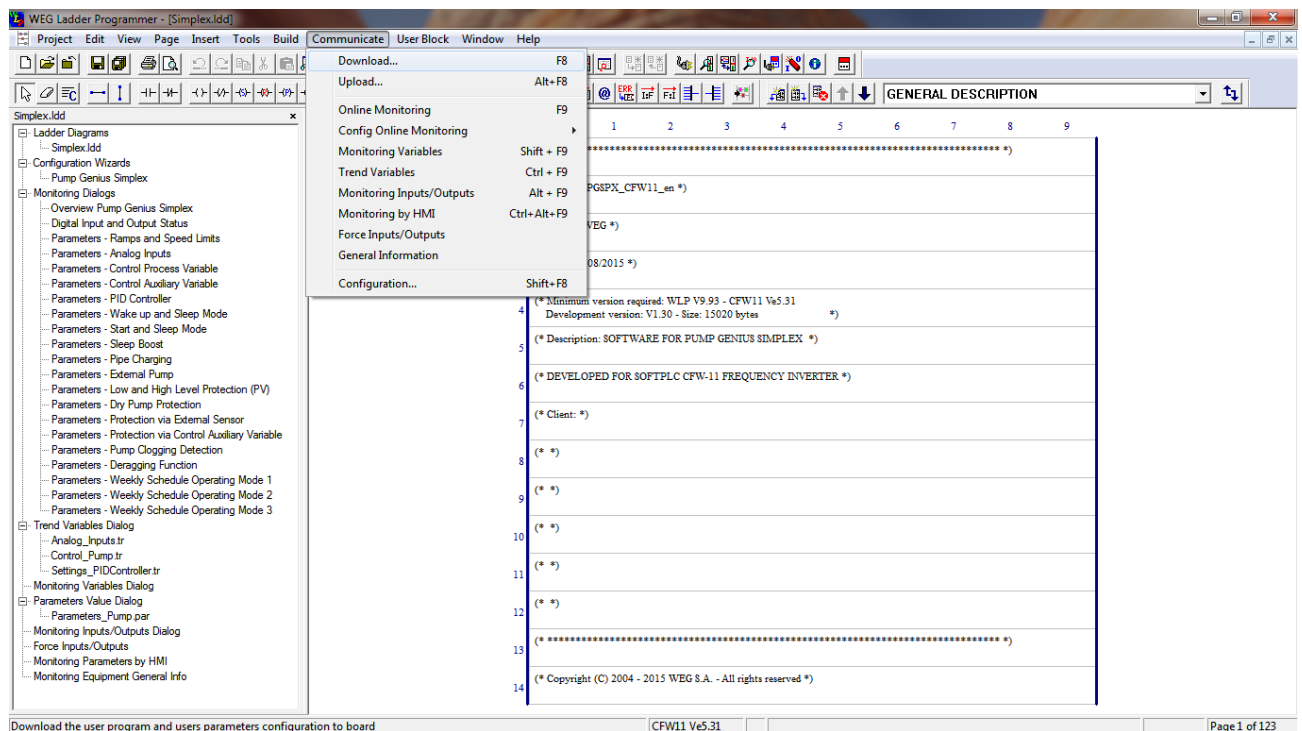

*Figure 4.4– Download the new project*

## Creation And Download the Application

**5<sup>th</sup> Step:** Select “User Program” and “Users Parameters Configuration” in the download dialog. Then click “OK” to start the transfer to the CFW-11 inverter;

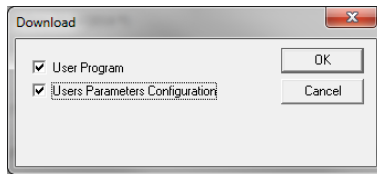

Figure 4.5 – Ladder application download dialog

**6<sup>th</sup> Step:** Download the ladder application to the CFW-11 inverter. For this, after the project is compiled and the CFW-11 inverter is identified, click "Yes" to start the download;

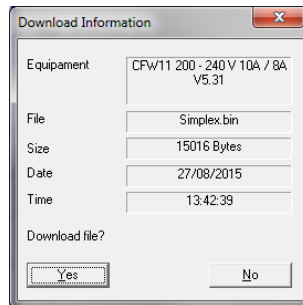

Figure 4.6 – User program download dialog

**7<sup>th</sup> Step:** Enable the execution of the SoftPLC user program after the download of the ladder application to the CFW-11 inverter. Click "Yes" to enable the execution of the SoftPLC user program.

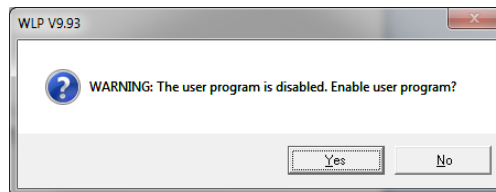

Figure 4.7 – Enabling dialog of the SoftPLC user's program

**8<sup>th</sup> Step:** Download the user's parameters configuration of the ladder application to the CFW-11 inverter. For this, click “Download” in the user parameters configuration dialog; and then, click "Yes" to start the download;

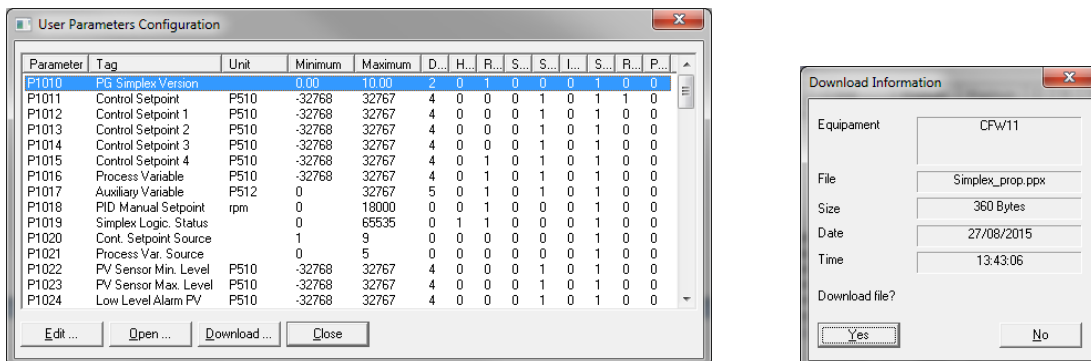

Figure 4.8 – User parameters download dialogs

## Creation And Download the Application

**9<sup>th</sup> Step:** Start the configuration wizard setup for Pump Genius Simplex application. For this, click the Configuration Wizard “Pump Genius Simplex” in the project tree bar and follow the steps described in chapter 5;

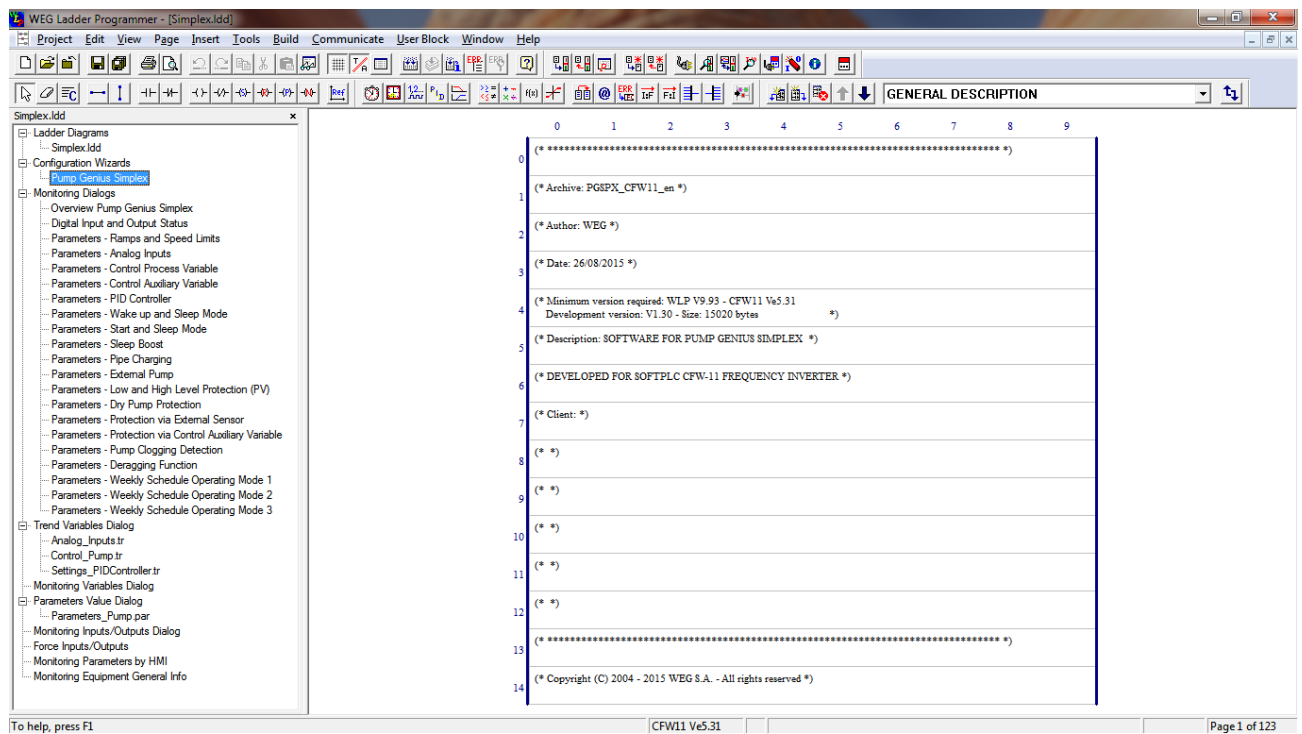

Figure 4.9 – Select the configuration wizard for Pump Genius Simplex

**10<sup>th</sup> Step:** Click "Finish" in the summary of Pump Genius Simplex configuration;

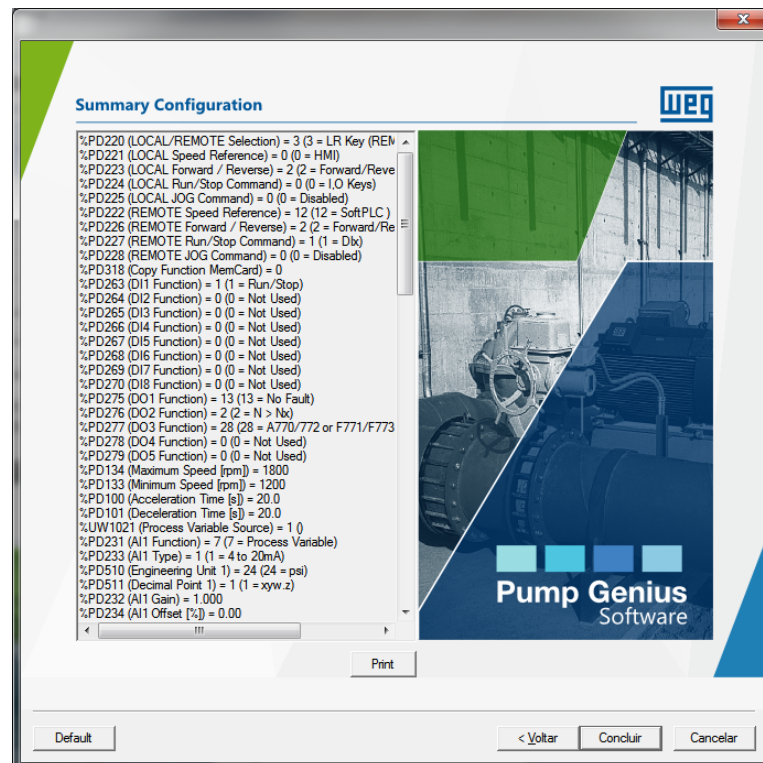
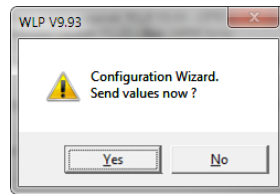

Figure 4.10 – Summary of Pump Genius Simplex configuration

## Creation And Download the Application

**11<sup>th</sup> Step:** Send the values of the parameters configured in the configuration wizard of Pump Genius Simplex for the CFW-11 inverter. For this, click "Yes" to start sending the values.



*Figure 4.11 – Dialog for download the values of configuration wizard*



**NOTE!**

After performing these steps, the CFW-11 inverter is configured for Pump Genius Simplex application.



## 5 APPLICATION CONFIGURATION WIZARD

The Pump Genius Simplex application can be configured with the WLP (WEG Ladder Programmer) software using the “Pump Genius Simplex” configuration wizard, which consists of an oriented step by step guide for the configuration of the parameters regarding the application.



**NOTE!**

When powering up the inverter for the first time follow the steps described in the chapter 5 “First time Power-up and Start-up” of the CFW-11 user’s guide inverter. It is recommended to use the V/f control mode for this type of application!

*Table 5.1 – Configuration wizard for Pump Genius Simplex application*

Step	Description	WLP Configuration Wizard
	General presentation of the Pump Genius Simplex configuration wizard.	
1	It presents to select whether there will be an external pump in Pump Genius.	

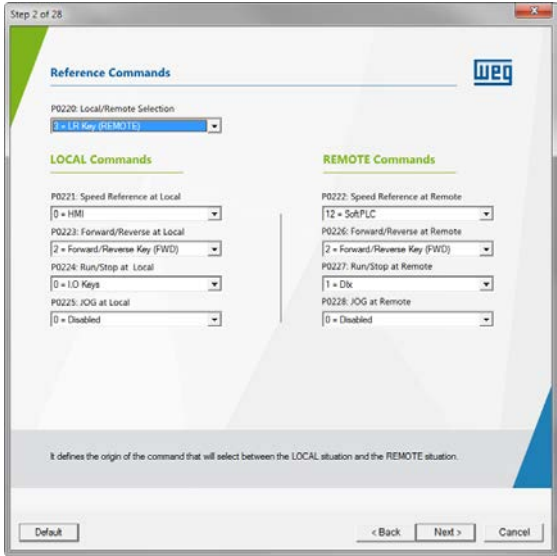
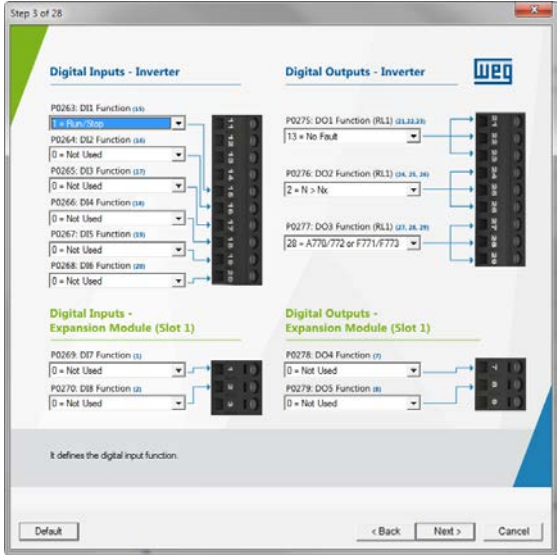
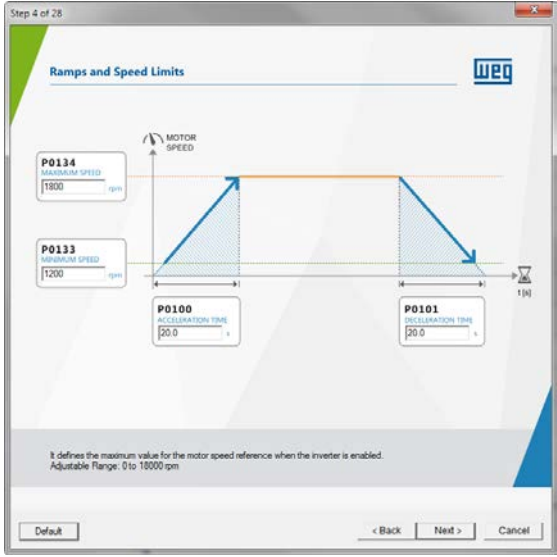
<p>2</p>	<p>It presents the parameters for the configuration of the origin of the commands:</p> <p>P0220: Local/Remote Selection Source</p> <p>P0221: Speed Reference Selection - Local Situation</p> <p>P0222: Speed Reference Selection - Remote Situation</p> <p>P0223: Forward/Reverse Selection - Local Situation</p> <p>P0224: Run/Stop Selection - Local Situation</p> <p>P0225: JOG Selection - Local Situation</p> <p>P0226: Forward/Reverse Selection - Remote Situation</p> <p>P0227: Run/Stop Selection - Remote Situation</p> <p>P0228: JOG Selection - Remote Situation</p>	
<p>3</p>	<p>It presents the parameters for the configuration of the functions of the CFW-11 digital inputs and outputs:</p> <p>P0263: DI1 Function</p> <p>P0264: DI2 Function</p> <p>P0265: DI3 Function</p> <p>P0266: DI4 Function</p> <p>P0267: DI5 Function</p> <p>P0268: DI6 Function</p> <p>P0269: DI7 Function</p> <p>P0270: DI8 Function</p> <p>P0275: DO1 Function (RL1)</p> <p>P0276: DO2 Function (RL2)</p> <p>P0277: DO3 Function (RL3)</p> <p>P0278: DO4 Function</p> <p>P0279: DO5 Function</p>	
<p>4</p>	<p>It presents the parameters for the configuration of the CFW-11 ramps and speed limits of the motor driven by the CFW-11:</p> <p>P0100: Acceleration Time</p> <p>P0101: Deceleration Time</p> <p>P0133: Minimum Speed Reference Limit</p> <p>P0134: Maximum Speed Reference Limit</p>	

<p>5</p>	<p>It presents the parameter for the source selection of the control process variable: P1021: Control Process Variable Selection Source</p>	
<p>6 - 1 to 6 - 5</p>	<p>It presents the parameters for the configuration of the control process variable via analog input AI1, AI2, AI3 or AI4 and the engineering unit of the control process variable: P0231, P0236, P0241 and P0246: AI1, AI2, AI3 and AI4 Signal Function P0233, P0238, P0243 and P0248: AI1, AI2, AI3 and AI4 Signal Type P0510: Engineering Unit 1 P0511: Decimal Point of Engineering Unit 1</p>	
<p>7 - 1 to 7 - 5</p>	<p>It presents the parameters for the configuration of the control process variable via analog input AI1, AI2, AI3 or AI4, and of the scale of the control process variable sensor: P0232, P0237, P0242 and P0247: AI1, AI2, AI3 and AI4 Gain P0234, P0239, P0244 and P0249: AI1, AI2, AI3 and AI4 Offset P0235, P0240, P0245 and P0250: AI1, AI2, AI3 and AI4 Filter P1022: Control Process Variable Sensor Minimum Level P1023: Control Process Variable Sensor Maximum Level</p>	

<p>8</p>	<p>It presents the parameter for selection the control action of the Pump Genius controller: P1028: Control Action of the PID Controller</p>	
<p>9</p>	<p>It presents the parameters for the configuration of the PID controller for the Pump Genius: P1018: Setpoint of the PID Controller in Manual mode P1029: Operation Mode of PID Controller P1030: Automatic Adjustment of the PID Controller Setpoint P1031: PID Proportional Gain P1032: PID Integral Gain P1033: PID Derivative Gain</p>	
<p>10</p>	<p>It presents the parameter for the source selection of the Pump Genius control setpoint in automatic mode: P1020: Control Setpoint Selection Source</p>	

<p>11</p>	<p>It presents the parameter for selection the action mode of schedules according to the day of week when the control setpoint is according to weekly schedule (P1020=9): P1063: Action Mode of Schedules according to the Day of Week</p>	
<p>12 – 1 to 12 – 4</p>	<p>It presents the parameters for the configuration of the control setpoint via analog input AI1, AI2, AI3 or AI4: P0231, P0236, P0241 and P0246: AI1, AI2, AI3 and AI4 Signal Function P0233, P0238, P0243 and P0248: AI1, AI2, AI3 and AI4 Signal Type P0232, P0237, P0242 and P0247: AI1, AI2, AI3 and AI4 Gain P0234, P0239, P0244 and P0249: AI1, AI2, AI3 and AI4 Offset P0235, P0240, P0245 and P0250: AI1, AI2, AI3 and AI4 Filter</p>	
<p>12 – 5</p>	<p>It presents the parameter for the configuration of the control setpoint via HMI or Communication Networks: P1011: Control Setpoint</p>	

<p>12 – 6 to 12 – 8</p>	<p>It presents the parameters for the configuration of the control setpoint via logical combination of digital inputs DI4 and DI5:                  P0266: DI4 Function                  P0267: DI5 Function                  P1012: Control Setpoint 1                  P1013: Control Setpoint 2                  P1014: Control Setpoint 3                  P1015: Control Setpoint 4</p>	
<p>12 - 9</p>	<p>It presents the parameters for configuration of weekly schedule:                  P1064, P1067, P1070, P1073, P1076, P1079, P1082, P1085, P1088, P1091, P1094 and P1097: Hour to Start the Schedule 1, 2, 3, 4, 5, 6, 7, 8, 9, 10, 11 and 12                  P1065, P1068, P1071, P1074, P1077, P1080, P1083, P1086, P1089, P1092, P1095 and P1098: Minute to Start the Schedule 1, 2, 3, 4, 5, 6, 7, 8, 9, 10, 11 and 12                  P1066, P1069, P1072, P1075, P1078, P1081, P1084, P1087, P1090, P1093, P1096 and P1099: Control Setpoint / Speed Reference of Schedule 1, 2, 3, 4, 5, 6, 7, 8, 9, 10, 11 and 12</p>	
<p>13</p>	<p>It presents the modes or conditions to startup the Pump Genius.</p>	



<p>14 – 1</p>	<p>It presents the parameters for the configuration of the sleep mode and wake up mode:                  P1034: Control Process Variable Deviation to Wake up the Pump Genius                  P1036: Time Delay to Wake up the Pump Genius                  P1037: Pump Motor Speed below which Pump Genius goes to Sleep Mode                  P1038: Time Delay for Pump Genius goes to Sleep Mode</p>	
<p>14 – 2</p>	<p>It presents the parameters for the configuration of the sleep mode and start level mode:                  P1035: Control Process Variable Level for Starting the Pump Genius                  P1036: Time Delay for Starting by Level the Pump Genius                  P1037: Pump Motor Speed below which Pump Genius goes to Sleep Mode                  P1038: Time Delay for Pump Genius goes to Sleep Mode</p>	
<p>15</p>	<p>It presents the parameters for configuration of the sleep boost:                  P1039: Sleep Boost Offset                  P1040: Sleep Boost Maximum Time</p>	

<p>16</p>	<p>It presents the parameters for the configuration of pipe charging using the pump driven by CFW-11 inverter:</p> <p>P0105: Enable Pipe Charging (1<sup>st</sup> / 2<sup>nd</sup> Ramp Selection)</p> <p>P0102: Acceleration Time 2</p> <p>P1041: Pipe Charging Time</p> <p>P1042: Maximum Output Current during the Pipe Charging</p>	
<p>17</p>	<p>It presents the parameters for the configuration of the external pump for jockey pump function:</p> <p>P1060: Process Variable Level for Stopping the External Pump</p> <p>P1061: Process Variable Level for Starting the External Pump</p> <p>P1062: Time Delay for Starting the External Pump</p>	
<p>18</p>	<p>It presents the parameters for the configuration of the low level protection for the control process variable (pipe breaking) and high level protection for process variable (pipe obstruction):</p> <p>P1024: Value for Low Level Alarm for the Control Process Variable</p> <p>P1025: Time Delay for Low Level Fault for the Control Process Variable (F771)</p> <p>P1026: Value for High Level Alarm for the Control Process Variable</p> <p>P1027: Time for High Level Fault for the Control Process Variable (F773)</p>	



<p>19</p>	<p>It presents the parameters for the configuration of the dry pump protection:</p> <p>P1043: Motor Speed for Dry Pump                  P1044: Motor Torque for Dry Pump                  P1045: Time Delay for Dry Pump Fault (F781)</p>	
<p>20</p>	<p>It presents the parameter for the configuration of the pump protection via external sensor (DI6):</p> <p>P0268: DI6 Function                  P1046: Time Delay for Pump Protection via External Sensor Fault (F783)</p>	
<p>21</p>	<p>It presents the parameter for the source selection of the control auxiliary variable for pump protection:</p> <p>P1047: Control Auxiliary Variable Selection Source for Pump Protection</p>	

## Application Configuration Wizard

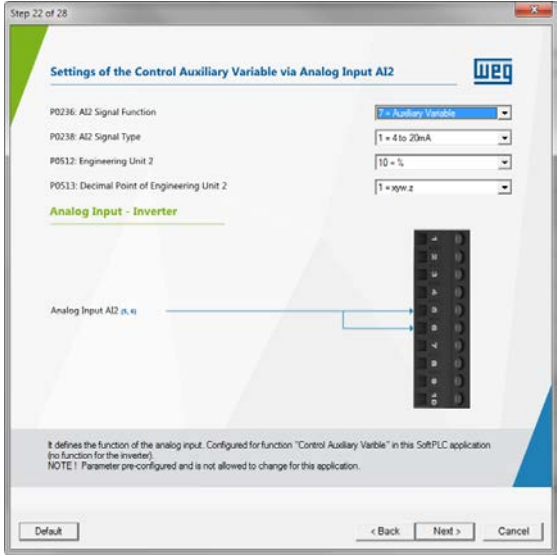
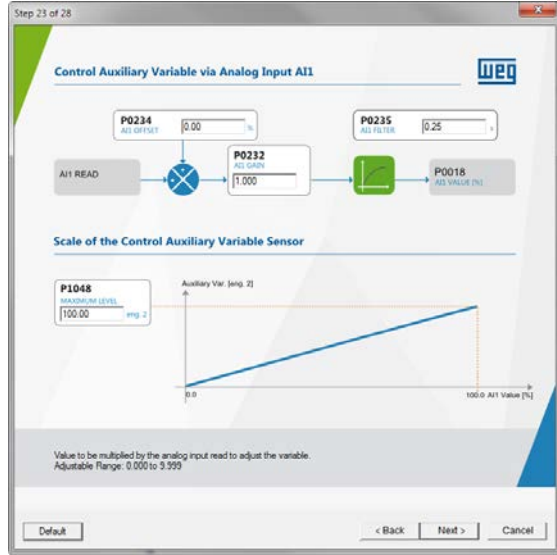
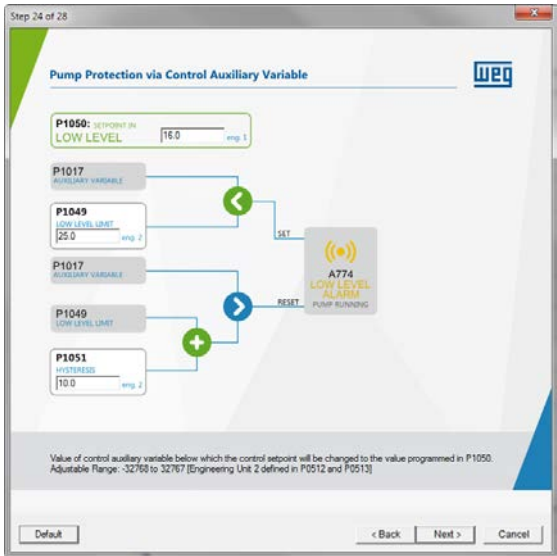
<p>22 – 1 to 22 – 4</p>	<p>It presents the parameters for the configuration of the control auxiliary variable for pump protection via analog input AI1, AI2, AI3 or AI4, and the engineering unit of the control auxiliary variable: P0231, P0236, P0241 and P0246: AI1, AI2, AI3 and AI4 Signal Function P0233, P0238, P0243 and P0248: AI1, AI2, AI3 and AI4 Signal Type P0512: Engineering Unit 2 P0513: Decimal Point of Engineering Unit 2</p>	
<p>23 – 1 to 23 – 4</p>	<p>It presents the parameters for the configuration of the control auxiliary variable for pump protection via analog input AI1, AI2, AI3 or AI4, and the scale of the control auxiliary variable sensor for pump protection: P0232, P0237, P0242 and P0247: AI1, AI2, AI3 and AI4 Gain P0234, P0239, P0244 and P0249: AI1, AI2, AI3 and AI4 Offset P0235, P0240, P0245 and P0250: AI1, AI2, AI3 and AI4 Filter P1048: Control Auxiliary Variable Sensor Maximum Level</p>	
<p>24</p>	<p>It presents the parameters for the configuration of the pump protection via control auxiliary variable: P1049: Value to detect Low Level of Control Auxiliary Variable P1050: Control Setpoint in Low Level P1051: Hysteresis to reactivate the Control Setpoint</p>	

<p>25</p>	<p>It presents the parameter for selection the execution mode of the deragging function: P1052: Execution Mode of the Deragging Function</p>	
<p>26</p>	<p>It presents the parameters for configuration of the pump clogging detection (P1052=3): P1057: Motor Current to detect the Clogging of Pump P1058: Time Delay to detect the Clogging of Pump P1059: Number of consecutives Clogging to generate the Fault (F791)</p>	
<p>27 – 1 to 27 – 3</p>	<p>It presents the parameters for configuration of the deragging function: P0222: Speed Reference Selection – Remote Situation P0226: Forward/Reverse Selection – Remote Situation P1053: Number of Cycles for Deragging P1054: Speed Reference for Deragging P1055: Deragging Run Time P1056: Deragging Stop Time</p>	

28

It presents the parameters that define which variables will be shown on the HMI display in the monitoring mode:

P0205: Reading Parameter Selection 1  
 P0206: Reading Parameter Selection 2  
 P0207: Reading Parameter Selection 3

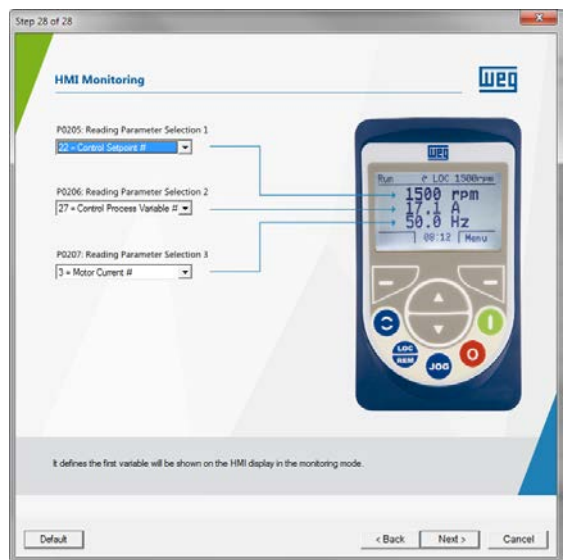

It presents a summary with all the parameters configured by the Pump Genius Simplex configuration wizard.

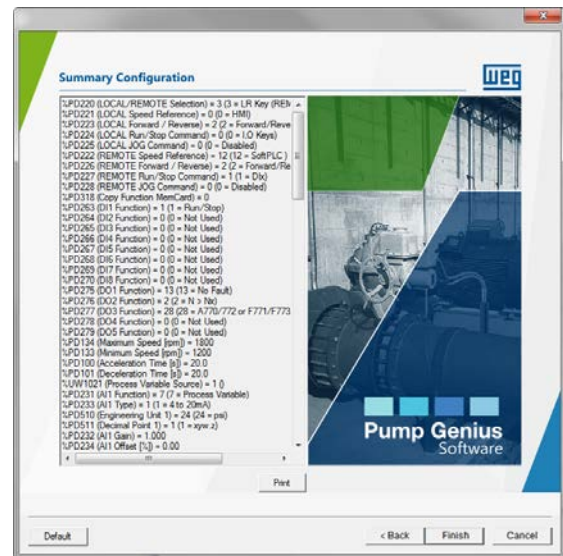

## Download Dialog Boxes

### 6 DOWNLOAD DIALOG BOXES

Through the WLP it is possible to download the user's ladder program, the configuration of user's parameters and the values configured in the configuration wizard. Below is a presentation of the main download dialogs to the CFW-11 inverter.



**NOTE!**

Refer to the help topics in the WLP programming software for more details on the download.

*Table 6.1 – Download dialog box for the Pump Genius Simplex application*

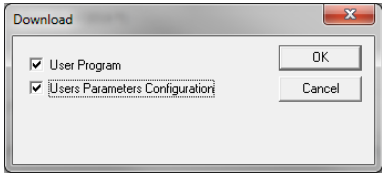
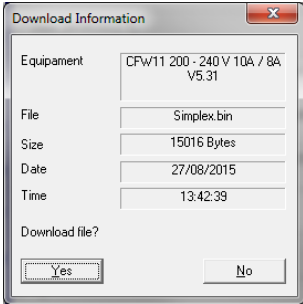
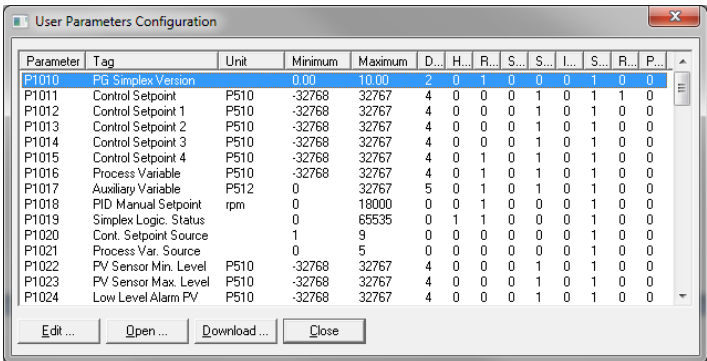
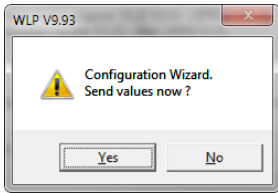
Description	WLP Download Dialog Box
<p>Download dialog box of the application developed with the WLP containing the following options:</p> <ul style="list-style-type: none"> <li>■ User Program;</li> <li>■ Configuration of the User's Parameters.</li> </ul>	
<p>User program download dialog box containing:</p> <ul style="list-style-type: none"> <li>■ Characteristics of the connected equipment;</li> <li>■ Name of the file to be downloaded;</li> <li>■ Size of the application to be downloaded;</li> <li>■ File compilation date;</li> <li>■ File compilation hour;</li> <li>■ Command to transfer or not the compiled application.</li> </ul>	
<p>Configuration of the user parameters dialog box containing:</p> <ul style="list-style-type: none"> <li>■ Parameter number;</li> <li>■ Name assigned to the parameter by the user;</li> <li>■ Unit assigned to the parameter by the user;</li> <li>■ Minimum and maximum values;</li> <li>■ Number of decimal positions;</li> <li>■ Options for visualization in hexadecimal format, with sign, ignoring the password, visualization on the HMI, retentive and for change confirmation;</li> <li>■ Commands for opening, editing, performing the download and for closing the dialog box of the user parameters.</li> </ul>	
<p>Dialog box for the download of the values configured with the Pump Genius Simplex configuration wizard.</p>	

## Monitoring Dialog Boxes

### 7 MONITORING DIALOG BOXES

It is possible to monitor and change the parameters of the Pump Genius Simplex application through the WLP.

*Table 7.1 – Monitoring dialogs of the Pump Genius Simplex application*

Description	WLP Monitoring Dialog
<p>Monitoring of the pump driven by CFW-11 inverter in the Pump Genius Simplex application. It permits visualization of the following variables:</p> <ul style="list-style-type: none"> <li>■ Actual control setpoint and control process variable displayed as engineering unit 1;</li> <li>■ Control auxiliary variable displayed as engineering unit 2;</li> <li>■ Frequency, current, torque and speed of pump driven by CFW-11 inverter;</li> <li>■ PID controller output;</li> <li>■ Command for starting the external pump via digital output DO1;</li> <li>■ Status of the pump indicating: Run/Stop Command, command for sleep mode, sleep boost in execution, pipe charging in execution, deragging in execution, low level and high level of the control process variable, low level of the control auxiliary variable, status of external sensor (DI6) and dry pump condition;</li> <li>■ Status of CFW-11 inverter indicating: general enabled, motor running, forward, remote situation, subtension, alarm active and fault active;</li> <li>■ Present alarm and fault;</li> <li>■ Command for reset of faults.</li> </ul>	
<p>Monitoring of the status of commands made at the pump driven by CFW-11 inverter. It permits the visualization of the following variables:</p> <ul style="list-style-type: none"> <li>■ Present status of CFW-11 digital inputs;</li> <li>■ Function of digital inputs for Pump Genius;</li> <li>■ Present status of CFW-11 digital outputs;</li> <li>■ Function of digital outputs for Pump Genius.</li> </ul>	

## Monitoring Dialog Boxes

It shows the parameters for reading the Pump Genius control signals via the CFW-11 analog inputs. It permits the modification and visualization of the following variables:

- P0018: AI1 Value;
- P0019: AI2 Value;
- P0029: AI3 Value;
- P0021: AI4 Value;
- P0232: AI1 Gain;
- P0234: AI1 Offset;
- P0235: AI1 Filter;
- P0237: AI2 Gain;
- P0239: AI2 Offset;
- P0240: AI2 Filter;
- P0242: AI3 Gain;
- P0244: AI3 Offset;
- P0245: AI3 Filter;
- P0247: AI4 Gain;
- P0249: AI4 Offset;
- P0250: AI4 Filter.

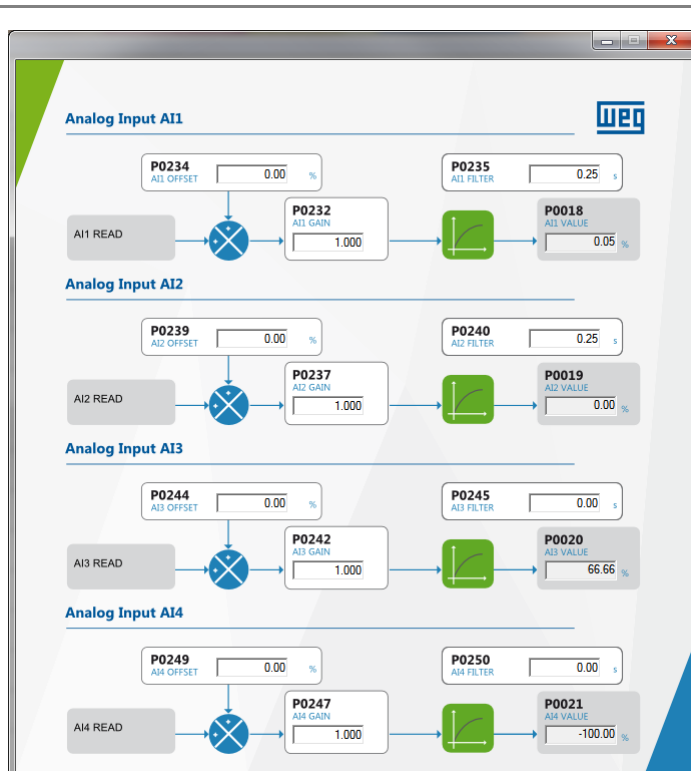

It shows the ramps and the speed limit parameters of the CFW-11 inverter, configured for the pump. It permits the modification of the following variables:

- P0100: Acceleration Time;
- P0101: Deceleration Time;
- P0133: Minimum Speed Reference Limit;
- P0134: Maximum Speed Reference Limit.

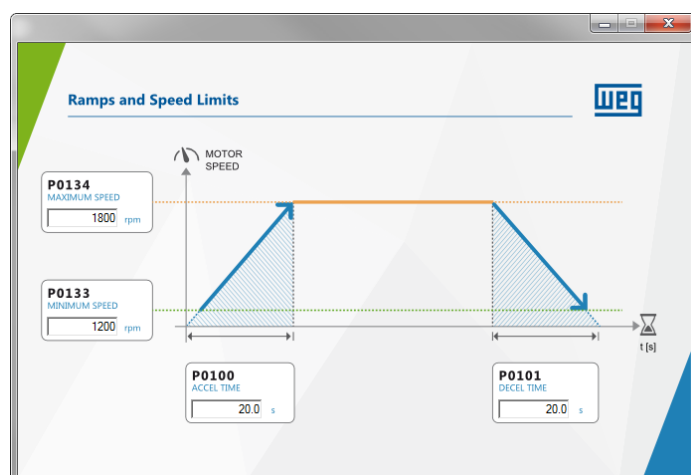

It shows the setting parameters of the control process variable. It permits the change and visualization of the following variables:

- P1022: Control Process Variable Sensor Minimum Level;
- P1023: Control Process Variable Sensor Maximum Level;
- Value of control process variable (P1016) displayed as engineering unit 1;
- Value of analog input selected for control process variable in %.

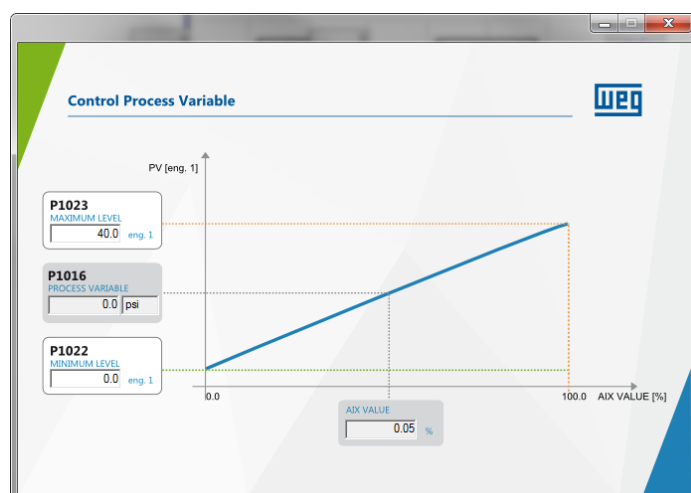



## Monitoring Dialog Boxes

It shows the setting parameters of the control auxiliary variable. It permits the change and visualization of the following variables:

- P1048: Control Auxiliary Variable Sensor Maximum Level (Range);
- Value of control auxiliary variable (P1017) as engineering unit 2;
- Value of analog input selected for control auxiliary variable in %.

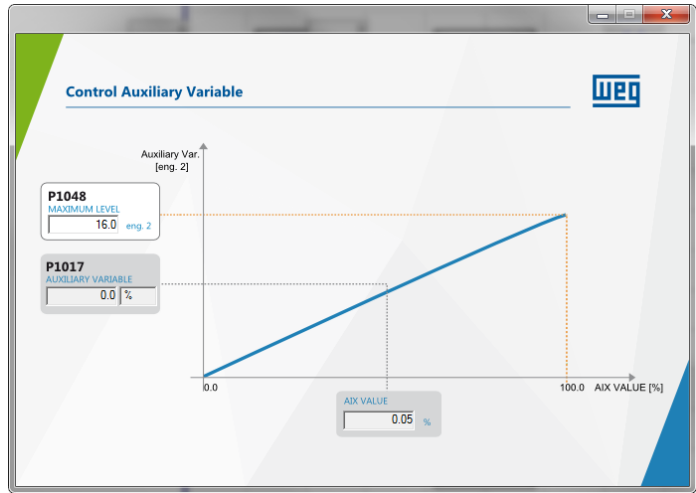

It shows the Pump Genius control's academic PID controller adjustment and operation parameters. It permits the modification and visualization of the following variables:

- P1011: Control Setpoint (read and write);
- P1012: Control Setpoint 1;
- P1013: Control Setpoint 2;
- P1014: Control Setpoint 3;
- P1015: Control Setpoint 4;
- P1016: Control Process Variable;
- P1018: Setpoint of the PID Controller in Manual mode;
- P1028: Control Action of the PID Controller (disabled, direct mode or reverse mode);
- P1029: Operation Mode of the PID Controller (manual or automatic);
- P1031: PID Proportional Gain;
- P1032: PID Integral Gain;
- P1033: PID Derivative Gain;
- Output (MV) of academic PID controller in %.

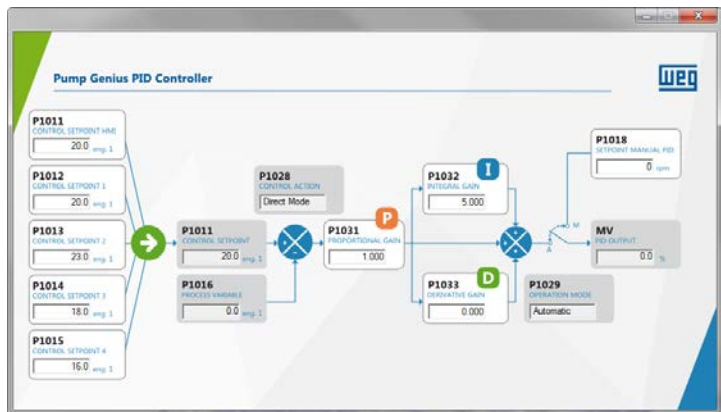

It shows the operation parameters for pipe charging using the pump driven by CFW-11 inverter. It permits the modification and visualization of the following variables:

- P0102: Acceleration Time 2;
- P0133: Minimum Speed Reference Limit;
- P1041: Pipe Charging Time;
- Value of the time elapsed of the pipe charging;
- Indication of pipe charging enabled.

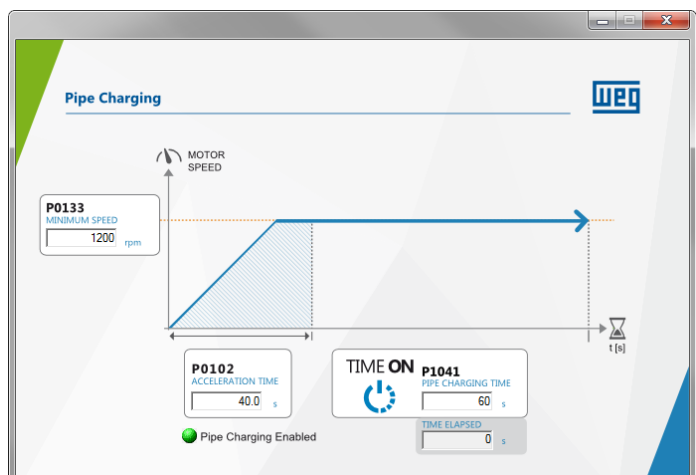



## Monitoring Dialog Boxes

It shows the operation parameters for executing the start and stops the Pump Genius with Wake up Mode configuration. It permits the modification and visualization of the following variables:

- P1011: Control Setpoint;
- P1016: Control Process Variable;
- P1028: Control Action of the PID Controller (disabled, direct mode or reverse mode);
- P1034: Control Process Variable Deviation to Wake up the Pump Genius;
- P1036: Time Delay to Wake up the Pump Genius;
- P1037: Pump Motor Speed below which Pump Genius goes to Sleep Mode;
- P1038: Time Delay for Pump Genius goes to Sleep Mode;
- Motor speed reference in rpm;
- Value of the time elapsed to wake up the Pump Genius;
- Value of the time elapsed for Pump Genius goes to sleep mode;
- Indication of wake up mode active;
- Indication of sleep mode or sleep boost active.

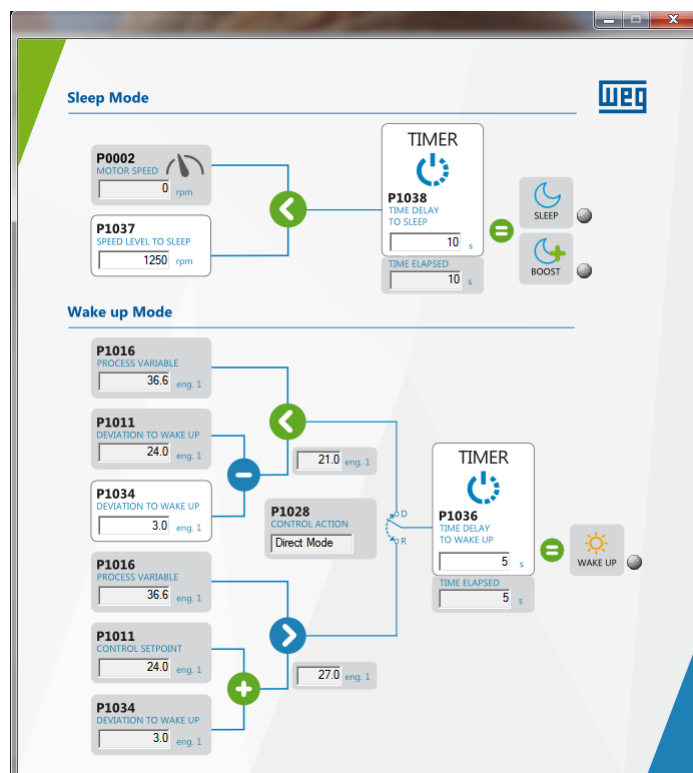

It shows the operation parameters for executing the start and stops the Pump Genius with Start Level Mode configuration. It permits the modification and visualization of the following variables:

- P1011: Control Setpoint;
- P1016: Control Process Variable;
- P1028: Control Action of the PID Controller (disabled, direct mode or reverse mode);
- P1035: Control Process Variable Level for Starting the Pump Genius;
- P1036: Time Delay for Starting by Level the Pump Genius;
- P1037: Pump Motor Speed below which Pump Genius goes to Sleep Mode;
- P1038: Time Delay for Pump Genius goes to Sleep Mode;
- Motor speed reference in rpm;
- Value of the time elapsed for starting by level the Pump Genius;
- Value of the time elapsed for Pump Genius control goes to sleep mode;
- Indication of start level mode active;
- Indication of sleep mode or sleep boost active.

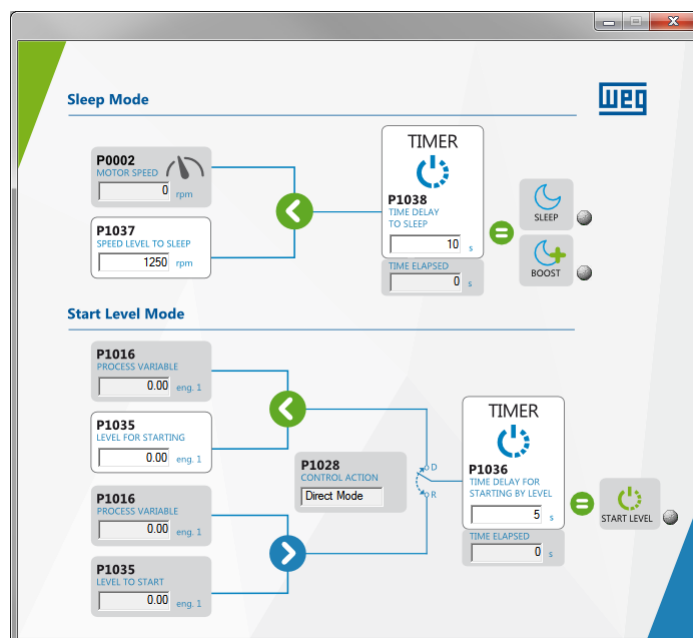

## Monitoring Dialog Boxes

It shows the operation parameters of sleep boost function. It permits the modification and visualization of the following variables:

- P1011: Control Setpoint;
- P1016: Control Process Variable;
- P1039: Sleep Boost Offset ;
- P1040: Sleep Boost Maximum time;
- Maximum time value elapsed of sleep boost;
- Indication of the sleep mode and sleep boost active.

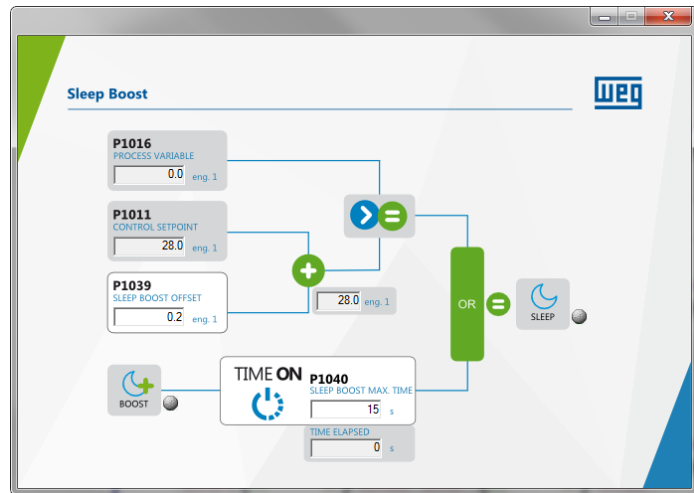

It shows the operation parameters of an external pump for jockey pump function. It permits the modification and visualization of the following variables:

- P1016: Control Process Variable;
- P1060: Process Variable Level for Stopping the External Pump;
- P1061: Process Variable Level for Starting the External Pump;
- P1062: Time Delay for Starting the External Pump;
- Value of the time elapsed for starting the external pump;
- Indication of command for start and stop the external pump via digital output DO1.

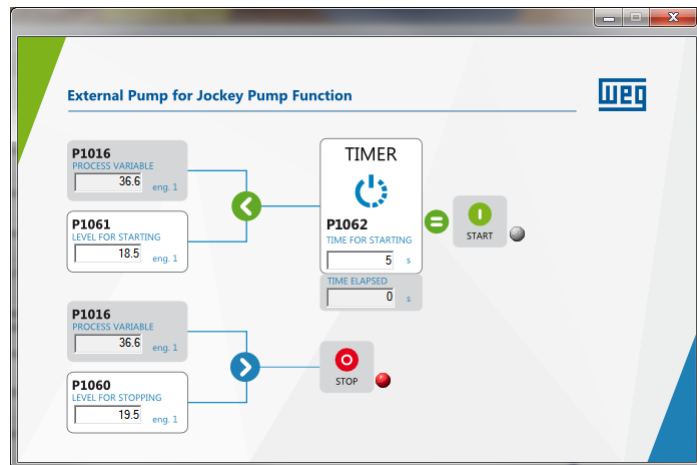

It shows the adjustment parameters of the low and high level protection for the control process variable. It permits the change and visualization of the following variables:

- P1016: Control Process Variable;
- P1024: Value for Low Level Alarm for the Control Process Variable;
- P1025: Time Delay for Low Level Fault for the Control Process Variable (F771);
- P1026: Value for High Level Alarm for the Control Process Variable;
- P1027: Time Delay for High Level Fault for the Control Process Variable (F773);
- Value of the time elapsed to generate the low level and high level fault for the control process variable;
- Indication of active alarms and faults.

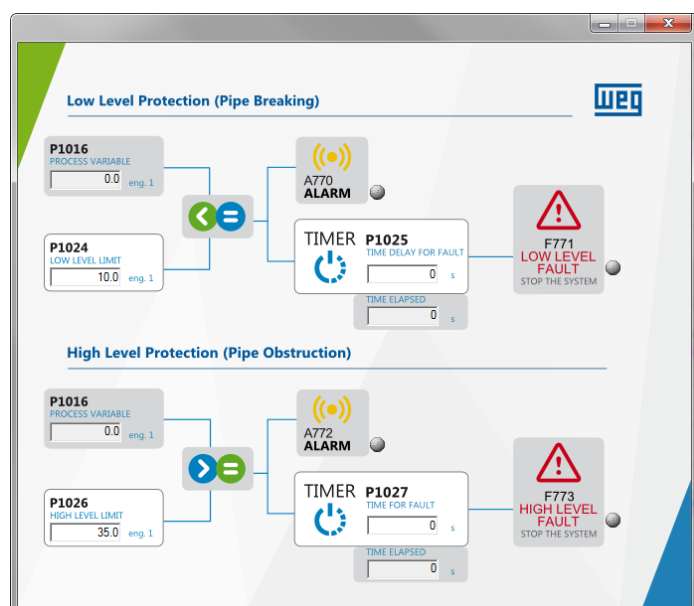

## Monitoring Dialog Boxes

It shows the adjustment parameters for dry pump protection.

It permits the change and visualization of the following variables:

- P0002: Actual Motor Speed in rpm;
- P0009: Actual Motor Torque in %;
- P1043: Motor Speed for Dry Pump;
- P1044: Motor Torque for Dry Pump;
- P1045: Time Delay for Dry Pump Fault (F781);
- Value of the time elapsed for generate the dry pump fault (F781);
- Indication of active alarm and fault.

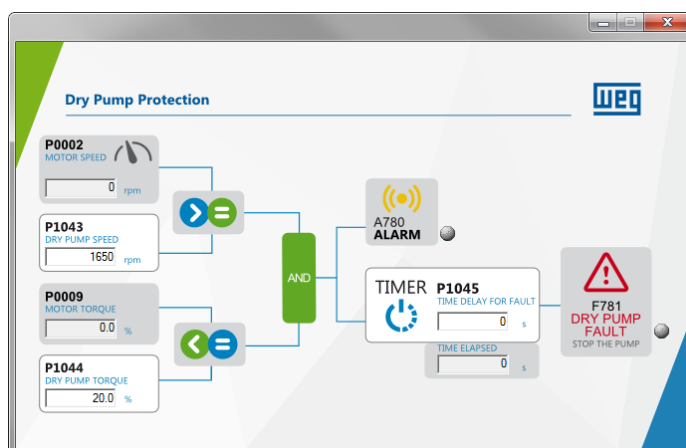

It shows the adjustment parameters for pump protection via external sensor in digital input DI6. It permits the change and visualization of the following variables:

- P1046: Time Delay for Pump Protection via External Sensor Fault (F783);
- Value of the time elapsed for generate the fault F783;
- Indication of sensor (DI6) enabled;
- Indication of status of sensor installed in digital input DI6;
- Indication of active alarm and fault.

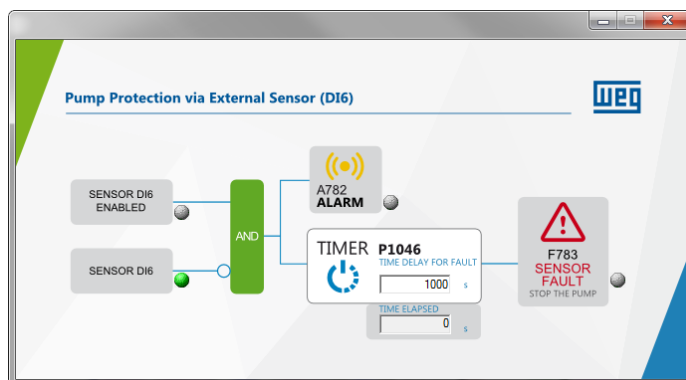

It shows the adjustment parameters for pump protection via control auxiliary variable. It permits the change and visualization of the following variables:

- P1011: Control Setpoint;
- P1017: Control Auxiliary Variable;
- P1049: Value to detect Low Level of Control Auxiliary Variable;
- P1050: Control Setpoint in Low Level;
- P1051: Hysteresis to reactivate the Control Setpoint;
- Indication of active alarm.

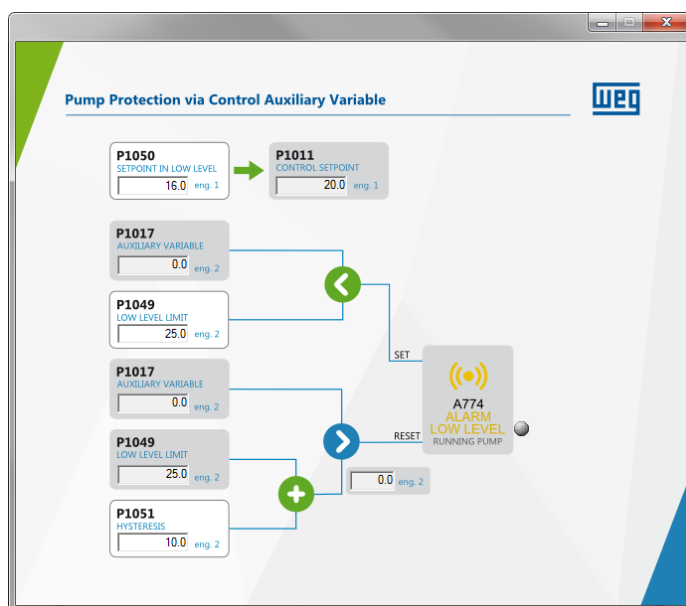

## Monitoring Dialog Boxes

It shows the adjustment parameters of deragging via Detection Clogging. It permits the change and visualization of the following variables:

- P0003: Actual Motor Current in A;
- P1057: Motor Current to detect Clogging of Pump;
- P1058: Time Delay to detect Clogging of Pump;
- P1059: Number of consecutives Clogging to generate the Fault (F791);
- Value of the time elapsed for clogging detection;
- Value of the number of clogging detected;
- Indication of the clogging detected;
- Indication of active fault.

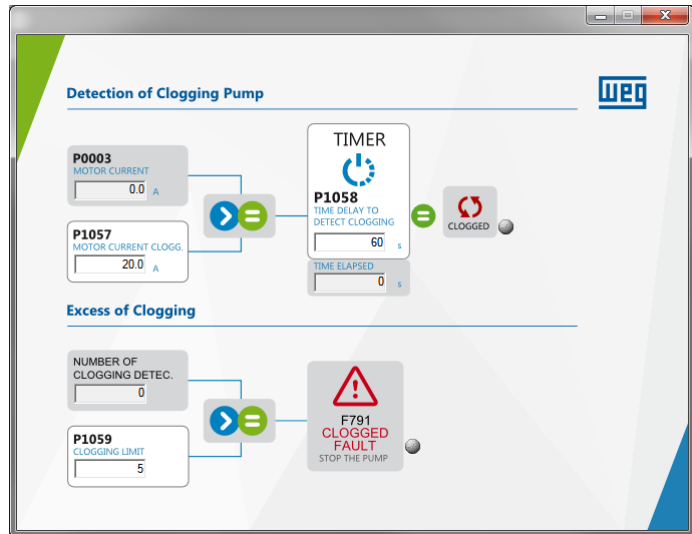

It shows the adjustment parameters of the deragging function. It permits the change and visualization of the following variables:

- P0002: Actual Motor Speed in rpm;
- P1053: Number of Cycles for Deragging;
- P1054: Speed Reference for Deragging;
- P1055: Deragging Run Time;
- P1056: Deragging Stop Time;
- Value of the deragging counter cycles;
- Value of the time elapsed for each step of the deragging function;
- Indication of the deragging function is in execution.

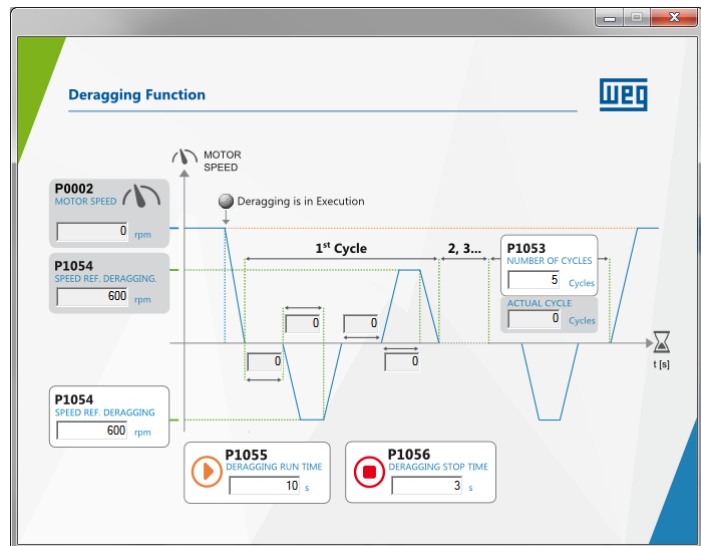

## Monitoring Dialog Boxes

It shows the adjustment parameters of control setpoint when is according to weekly schedule (P1020=9) and the action mode of Schedule 1 to 12 from Monday to Sunday (P1063=1). It permits the change and visualization of the following variables:

- P1064, P1067, P1070, P1073, P1076, P1079, P1082, P1085, P1088, P1091, P1094 and P1097: Hour to Start the Schedule 1, 2, 3, 4, 5, 6, 7, 8, 9, 10, 11 and 12.
- P1065, P1068, P1071, P1074, P1077, P1080, P1083, P1086, P1089, P1092, P1095 and P1098: Minute to Start the Schedule 1, 2, 3, 4, 5, 6, 7, 8, 9, 10, 11 and 12.
- P1066, P1069, P1072, P1075, P1078, P1081, P1084, P1087, P1090, P1093, P1096 and P1099: Control Setpoint of Schedule 1, 2, 3, 4, 5, 6, 7, 8, 9, 10, 11 and 12.
- Indication of weekly schedule (P1063=1) enabled;
- Indication of day of week, date and time in the CFW-11 inverter;
- Indication of schedules enabled and which schedule is in execution (ON);
- Indication of the end of schedule (final time).

EN	ON	Schedules	SP / Speed	Initial Time	Final Time
<input checked="" type="checkbox"/>	<input type="checkbox"/>	Schedule 1	20.0	4 : 0	9 : 0
<input checked="" type="checkbox"/>	<input type="checkbox"/>	Schedule 2	24.0	9 : 0	17 : 0
<input checked="" type="checkbox"/>	<input checked="" type="checkbox"/>	Schedule 3	28.0	17 : 0	22 : 0
<input checked="" type="checkbox"/>	<input type="checkbox"/>	Schedule 4	14.0	22 : 0	4 : 0
<input type="checkbox"/>	<input type="checkbox"/>	Schedule 5	0.0	24 : 0	4 : 0
<input type="checkbox"/>	<input type="checkbox"/>	Schedule 6	0.0	24 : 0	4 : 0
<input type="checkbox"/>	<input type="checkbox"/>	Schedule 7	0.0	24 : 0	4 : 0
<input type="checkbox"/>	<input type="checkbox"/>	Schedule 8	0.0	24 : 0	4 : 0
<input type="checkbox"/>	<input type="checkbox"/>	Schedule 9	0.0	24 : 0	4 : 0
<input type="checkbox"/>	<input type="checkbox"/>	Schedule 10	0.0	24 : 0	4 : 0
<input type="checkbox"/>	<input type="checkbox"/>	Schedule 11	0.0	24 : 0	4 : 0
<input type="checkbox"/>	<input type="checkbox"/>	Schedule 12	0.0	24 : 0	4 : 0

It shows the adjustment parameters of control setpoint when is according to weekly schedule (P1020=9) and the action mode of Schedule 1 to 6 from Monday to Friday and Schedule 7 to 12 on Saturday and Sunday (P1063=2). It permits the change and visualization of the following variables:

- P1064, P1067, P1070, P1073, P1076, P1079, P1082, P1085, P1088, P1091, P1094 and P1097: Hour to Start the Schedule 1, 2, 3, 4, 5, 6, 7, 8, 9, 10, 11 and 12.
- P1065, P1068, P1071, P1074, P1077, P1080, P1083, P1086, P1089, P1092, P1095 and P1098: Minute to Start the Schedule 1, 2, 3, 4, 5, 6, 7, 8, 9, 10, 11 and 12.
- P1066, P1069, P1072, P1075, P1078, P1081, P1084, P1087, P1090, P1093, P1096 and P1099: Control Setpoint of Schedule 1, 2, 3, 4, 5, 6, 7, 8, 9, 10, 11 and 12.
- Indication of weekly schedule (P1063=2) enabled;
- Indication of day of week, date and time in the CFW-11 inverter;
- Indication of schedules enabled and which schedule is in execution (ON);
- Indication of the end of schedule (final time).

EN	ON	Schedules	SP / Speed	Initial Time	Final Time
<input checked="" type="checkbox"/>	<input type="checkbox"/>	Schedule 1	20.0	4 : 0	9 : 0
<input checked="" type="checkbox"/>	<input type="checkbox"/>	Schedule 2	24.0	9 : 0	17 : 0
<input checked="" type="checkbox"/>	<input checked="" type="checkbox"/>	Schedule 3	28.0	17 : 0	22 : 0
<input checked="" type="checkbox"/>	<input type="checkbox"/>	Schedule 4	14.0	22 : 0	4 : 0
<input type="checkbox"/>	<input type="checkbox"/>	Schedule 5	0.0	24 : 0	4 : 0
<input type="checkbox"/>	<input type="checkbox"/>	Schedule 6	0.0	24 : 0	4 : 0

**NOTE!** The transition from Friday to Saturday, the Final Time of the last Sch. enabled is the Initial Time of Sch. 7.

EN	ON	Schedules	SP / Speed	Initial Time	Final Time
<input checked="" type="checkbox"/>	<input type="checkbox"/>	Schedule 7	20.0	4 : 0	9 : 0
<input checked="" type="checkbox"/>	<input type="checkbox"/>	Schedule 8	24.0	9 : 0	17 : 0
<input checked="" type="checkbox"/>	<input type="checkbox"/>	Schedule 9	28.0	17 : 0	22 : 0
<input checked="" type="checkbox"/>	<input type="checkbox"/>	Schedule 10	14.0	22 : 0	4 : 0
<input type="checkbox"/>	<input type="checkbox"/>	Schedule 11	0.0	24 : 0	4 : 0
<input type="checkbox"/>	<input type="checkbox"/>	Schedule 12	0.0	24 : 0	4 : 0

**NOTE!** The transition from Sunday to Monday, the Final Time of the last Sch. enabled is the Initial Time of Sch. 1.

# Monitoring Dialog Boxes

It shows the adjustment parameters of control setpoint when is according to weekly schedule (P1020=9) and the action mode of Schedule 1 to 4 from Monday to Friday , Schedule 5 to 8 on Saturday and Schedule 9 to 12 on Sunday (P1063=3). It permits the change and visualization of the following variables:

- P1064, P1067, P1070, P1073, P1076, P1079, P1082, P1085, P1088, P1091, P1094 and P1097: Hour to Start the Schedule 1, 2, 3, 4, 5, 6, 7, 8, 9, 10, 11 and 12.
- P1065, P1068, P1071, P1074, P1077, P1080, P1083, P1086, P1089, P1092, P1095 and P1098: Minute to Start the Schedule 1, 2, 3, 4, 5, 6, 7, 8, 9, 10, 11 and 12.
- P1066, P1069, P1072, P1075, P1078, P1081, P1084, P1087, P1090, P1093, P1096 and P1099: Control Setpoint of Schedule 1, 2, 3, 4, 5, 6, 7, 8, 9, 10, 11 and 12.
- Indication of weekly schedule (P1063=3) enabled;
- Indication of day of week, date and time in the CFW-11 inverter;
- Indication of schedules enabled and which schedule is in execution (ON);
- Indication of the end of schedule (final time).

**Schedule Status in the CFW-11 Inverter**

Schedule Enabled      Day of Week:

Date:       Time:

**Schedule 1 to 4 from Monday to Friday**

EN	ON	Schedules	SP / Speed	Initial Time	Final Time
<input checked="" type="checkbox"/>	<input type="checkbox"/>	Schedule 1	<input type="text" value="20.0"/>	<input type="text" value="4:0"/>	<input type="text" value="9:0"/>
<input checked="" type="checkbox"/>	<input type="checkbox"/>	Schedule 2	<input type="text" value="24.0"/>	<input type="text" value="9:0"/>	<input type="text" value="17:0"/>
<input checked="" type="checkbox"/>	<input type="checkbox"/>	Schedule 3	<input type="text" value="28.0"/>	<input type="text" value="17:0"/>	<input type="text" value="22:0"/>
<input checked="" type="checkbox"/>	<input type="checkbox"/>	Schedule 4	<input type="text" value="14.0"/>	<input type="text" value="22:0"/>	<input type="text" value="4:0"/>

**NOTE!** The transition from Friday to Saturday, the Final Time of the last Sch. enabled is the Inicial time 5.

**Schedule 5 to 8 on Saturday**

EN	ON	Schedules	SP / Speed	Initial Time	Final Time
<input checked="" type="checkbox"/>	<input type="checkbox"/>	Schedule 5	<input type="text" value="20.0"/>	<input type="text" value="4:0"/>	<input type="text" value="9:0"/>
<input checked="" type="checkbox"/>	<input type="checkbox"/>	Schedule 6	<input type="text" value="24.0"/>	<input type="text" value="9:0"/>	<input type="text" value="4:0"/>
<input checked="" type="checkbox"/>	<input type="checkbox"/>	Schedule 7	<input type="text" value="28.0"/>	<input type="text" value="17:0"/>	<input type="text" value="22:0"/>
<input checked="" type="checkbox"/>	<input type="checkbox"/>	Schedule 8	<input type="text" value="14.0"/>	<input type="text" value="22:0"/>	<input type="text" value="4:0"/>

**NOTE!** The Transition from Saturday to Sunday, the Final Time of the last Sch. enabled is the Initial Time of Sch. 9.

**Schedule 9 to 12 on Sunday**

EN	ON	Schedules	SP / Speed	Initial Time	Final Time
<input checked="" type="checkbox"/>	<input type="checkbox"/>	Schedule 9	<input type="text" value="20.0"/>	<input type="text" value="4:0"/>	<input type="text" value="9:0"/>
<input checked="" type="checkbox"/>	<input type="checkbox"/>	Schedule 10	<input type="text" value="24.0"/>	<input type="text" value="9:0"/>	<input type="text" value="17:0"/>
<input checked="" type="checkbox"/>	<input type="checkbox"/>	Schedule 11	<input type="text" value="28.0"/>	<input type="text" value="17:0"/>	<input type="text" value="22:0"/>
<input checked="" type="checkbox"/>	<input type="checkbox"/>	Schedule 12	<input type="text" value="14.0"/>	<input type="text" value="22:0"/>	<input type="text" value="4:0"/>

**NOTE!** The Transition form Sunday to Monday, The Final Time of the Last Sch. enabled is the Initial Time of Sch. 1.

## Trend Variables Dialog Boxes

### 8 TREND VARIABLES DIALOG BOXES

It is possible to monitor variables of the Pump Genius Simplex application through the WLP.

#### PID Controller Settings:

It permits the visualization of the values for the Pump Genius control's PID controller settings.

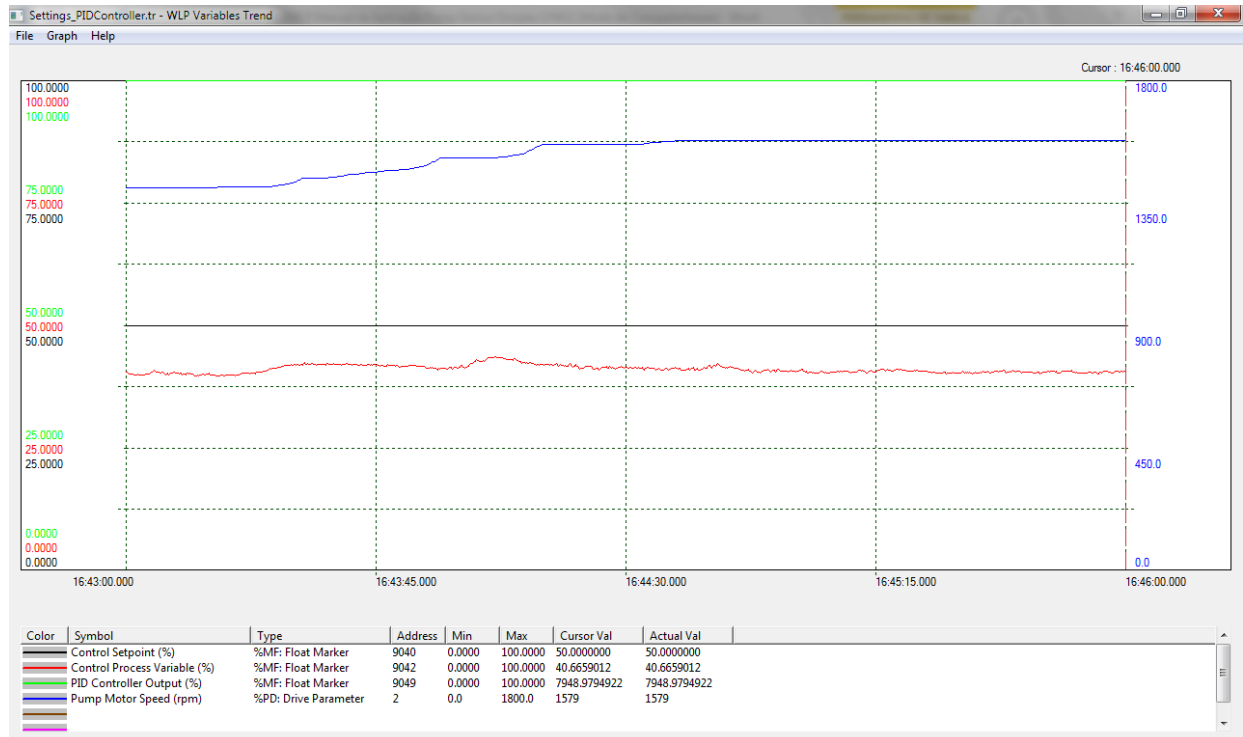

Figure 8.1 – Trend variable dialog for PID controller settings

#### Control of the Pump driven by CFW-11 Inverter:

It permits the visualization of control values of the pump driven by CFW-11 inverter.

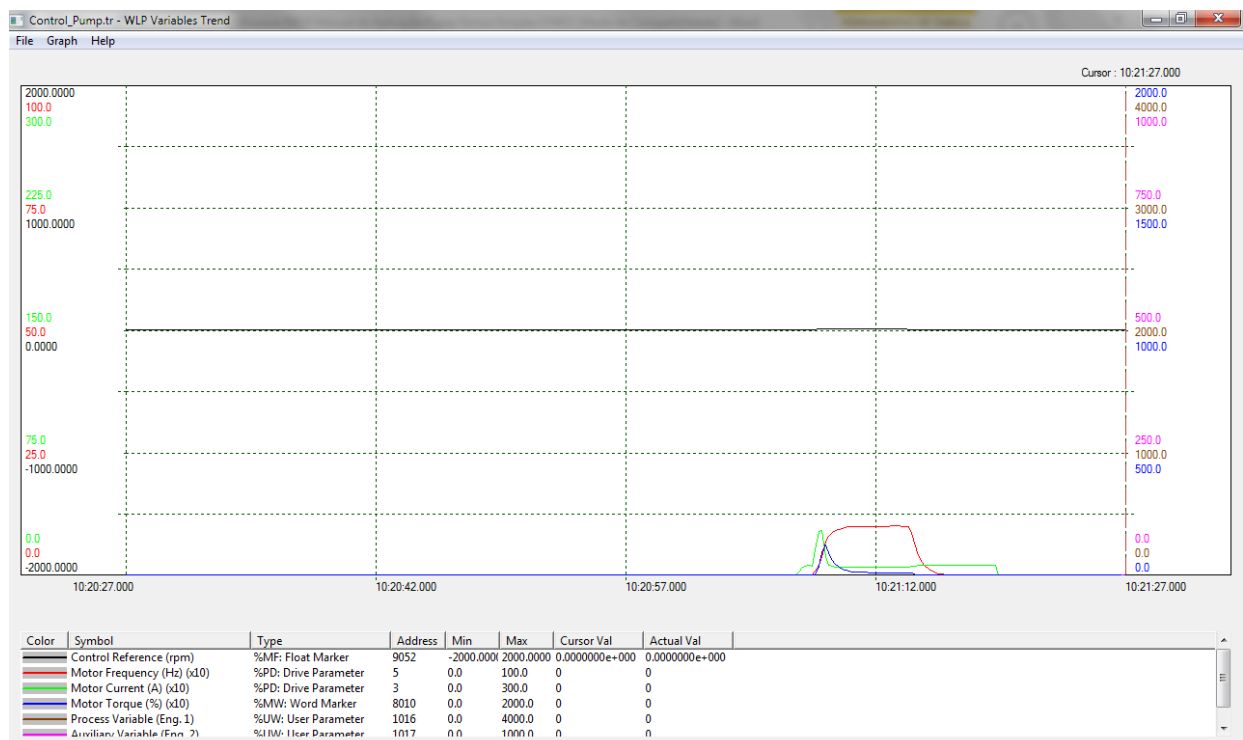

Figure 8.2 – Trend variable dialog for control values of the pump driven by CFW-11 inverter

# Trend Variables Dialog Boxes

## Analog Inputs:

It permits the visualization of the analog inputs values for an analysis of the response throughout the operation time.

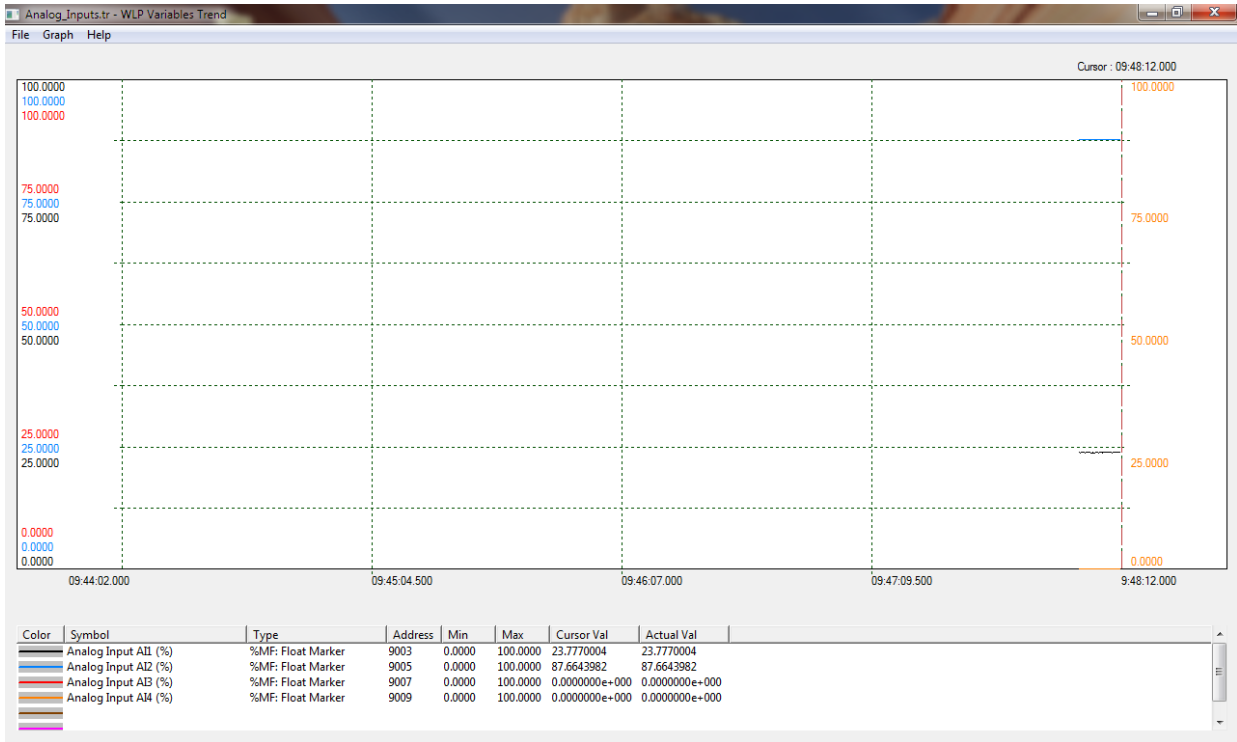

Figure 8.3 – Trend variable dialog for analog inputs



**NOTE!**

Refer to the WLP programming software help topics for more information on the use of the trend variables.



### 9 PARAMETER VALUE DIALOG

It is possible to save the parameters of the pump configured in the Pump Genius Simplex application through the WLP.

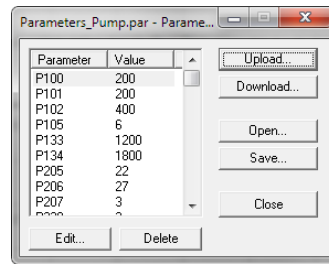

*Figure 9.1 – Parameter value dialog*



**NOTE!**

Refer to the WLP programming software help topics for more information on the use of the parameter value dialog box.