

MW500 – DECENTRALIZED VFD – MOTORDRIVE

Industrial Motors

Commercial &
Appliance Motors

Automation

Digital &
Systems

Energy

Transmission &
Distribution

Coatings

**For decentralized
solutions,** the VFD
wherever you need it.



Driving efficiency and sustainability





S U M M A R Y

Introduction	04
Easy configuration	06
Connectivity	08
Features	09
Built-in safety functions	10
Applications	11
Special characteristics	12
Coding	13
Specifications	14
Accessories	16
Dimensions and weights	17
Motor and drive mechanical mounting combination	18
Standards	20
Technical data	21
Block diagram	22



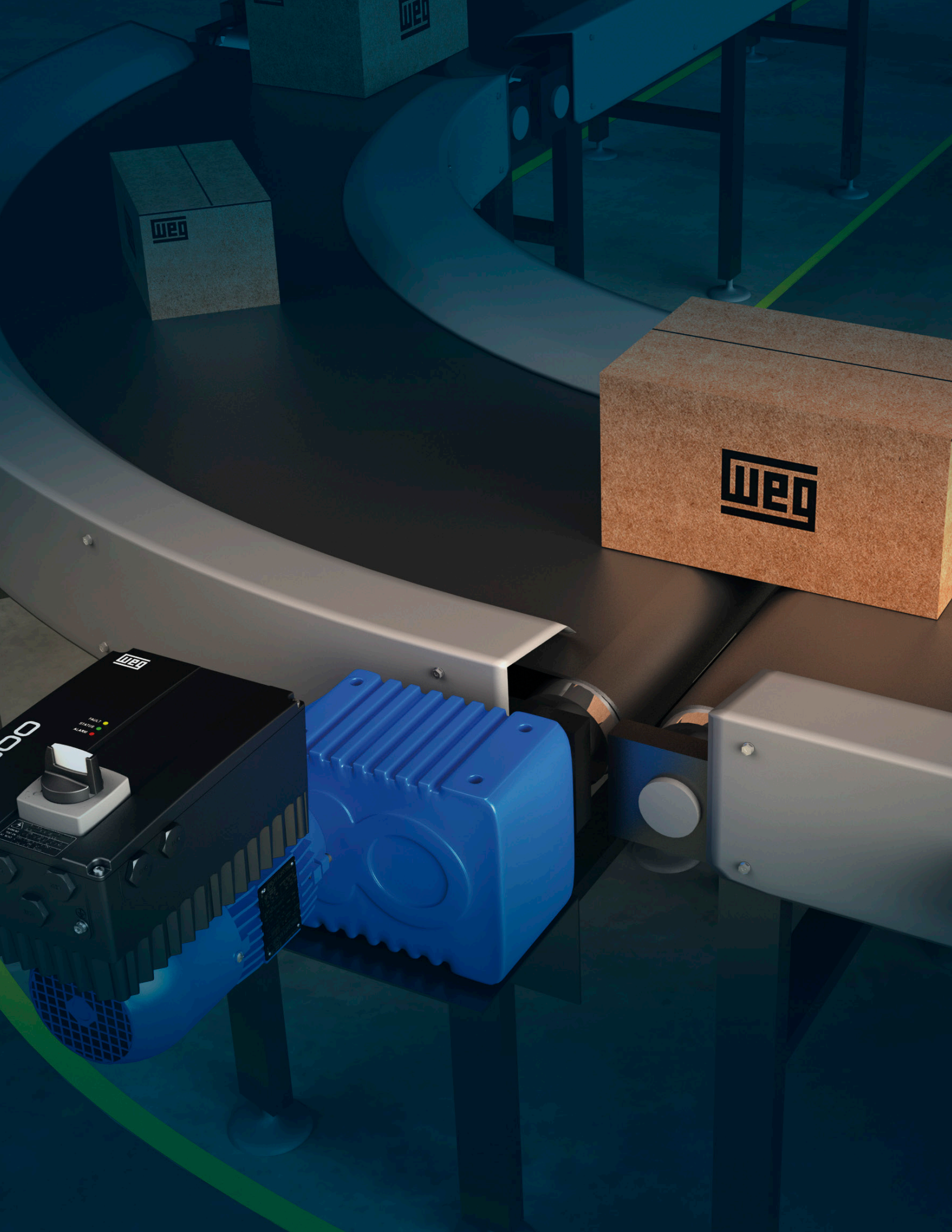

MW500

For decentralized solutions, the VFD wherever you need it.

The MW500 is a high-performance frequency inverter used to control three-phase induction motors. Its dedicated functions and **high degree of protection (IP66/NEMA 4X)** allow its use in applications that require a **high level of precision and robustness**. Furthermore, the MW500 presents excellent **flexibility**, as it can be directly installed on the wall or mounted on the motor, reducing the cabling and panel costs.

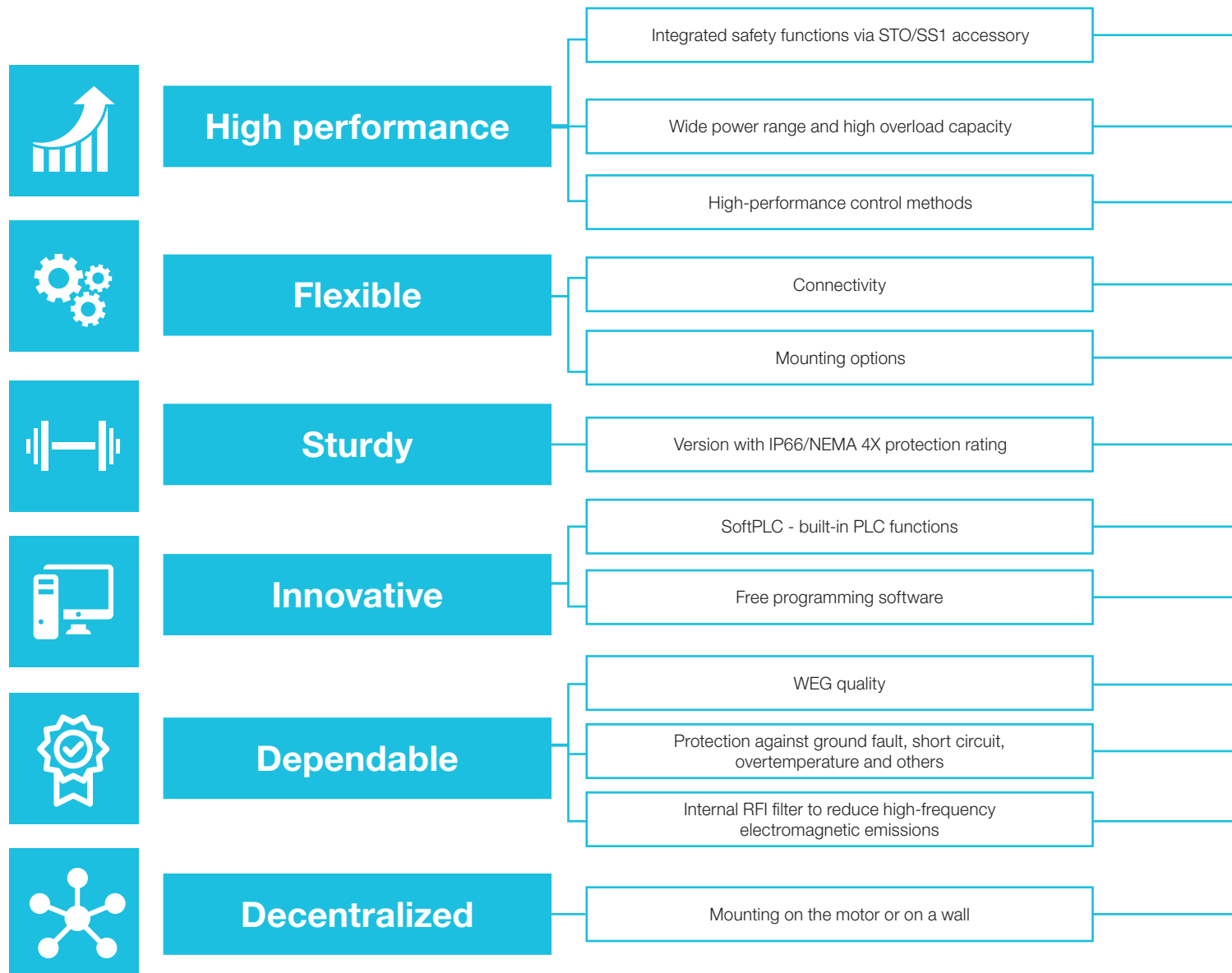

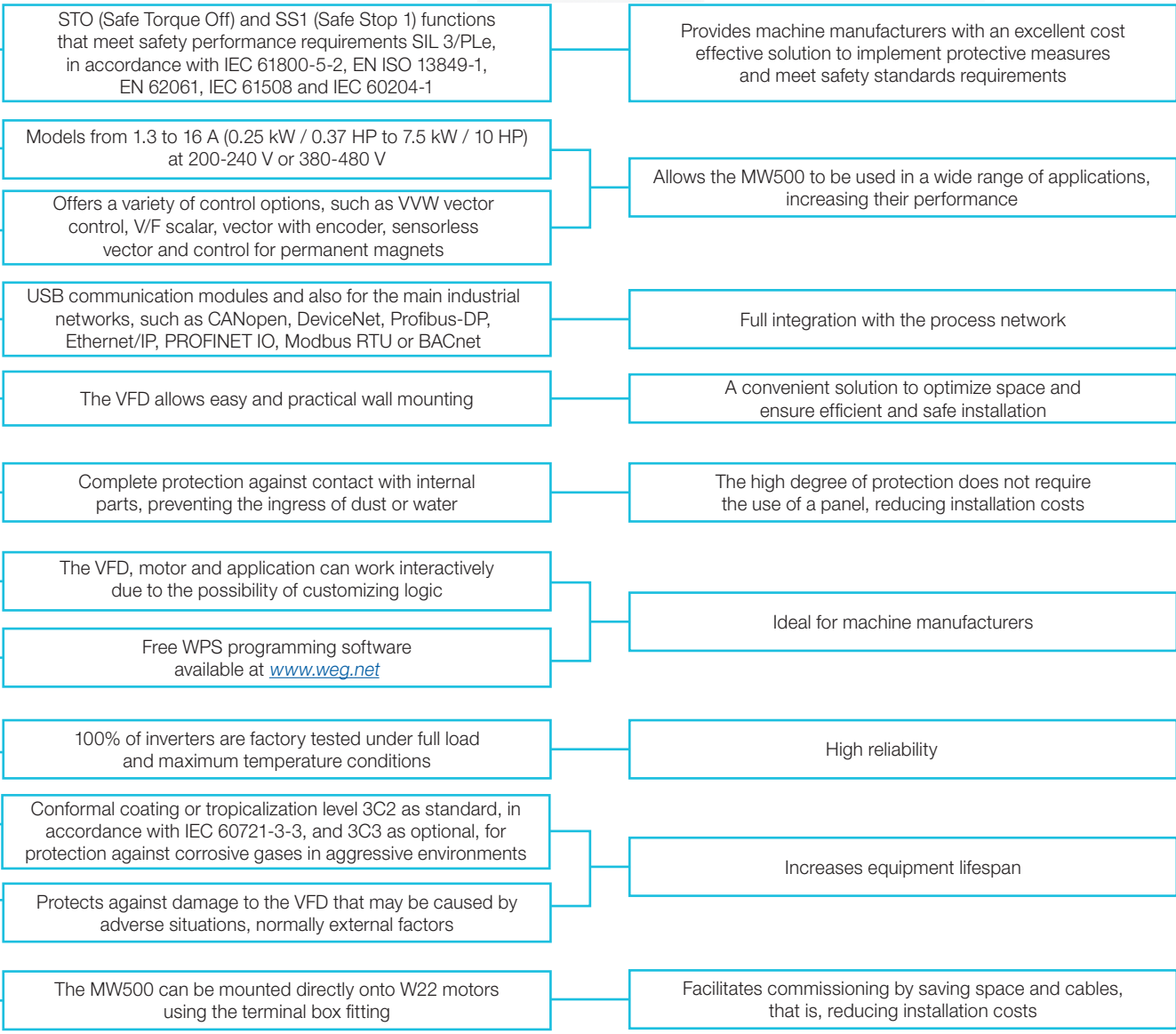

Easy configuration

Main components

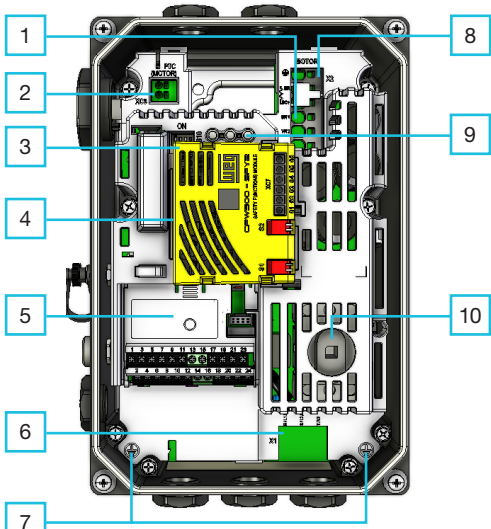
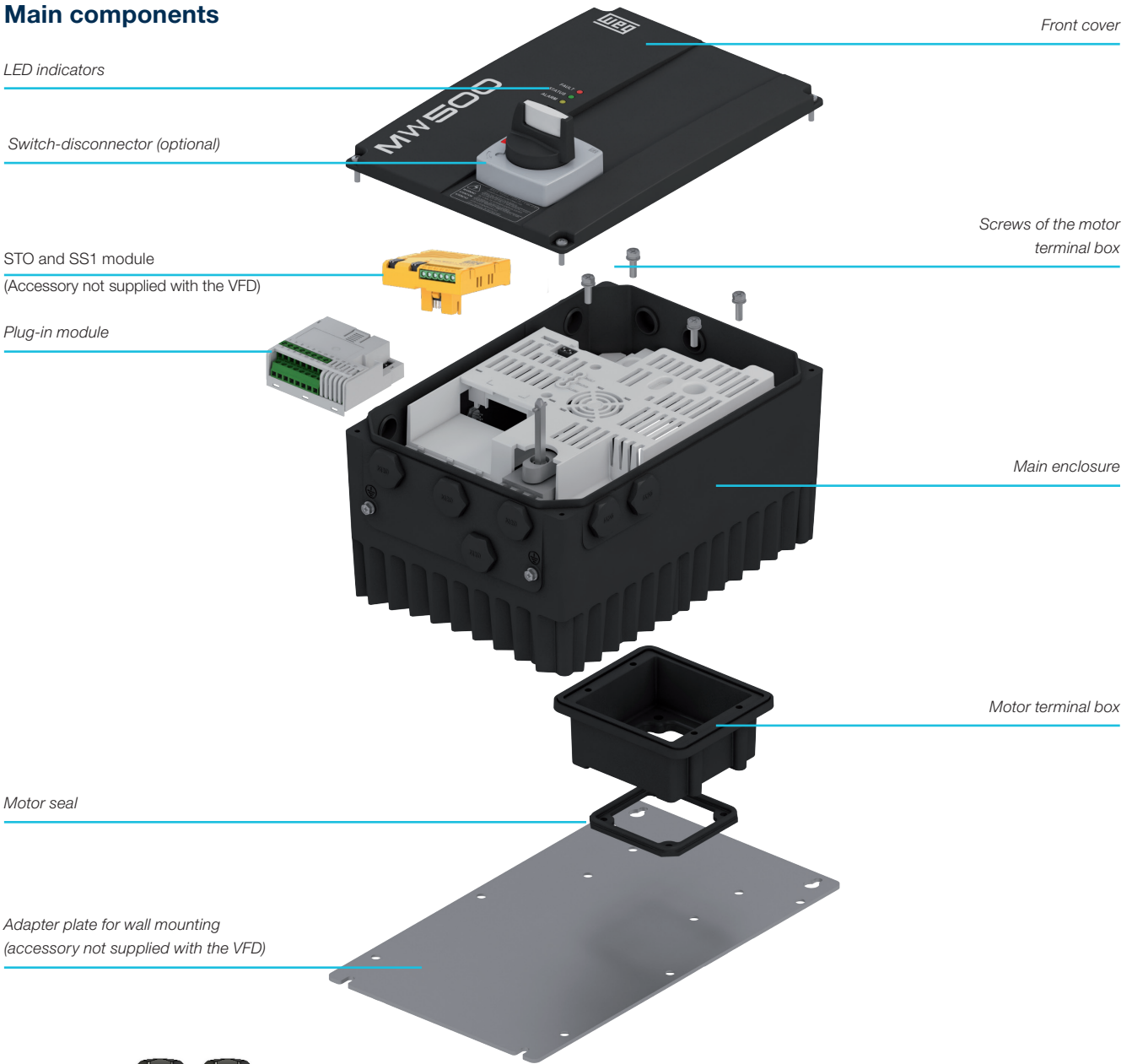

- 1 - Motor connection
- 2 - Motor PTC input
- 3 - S10 DIP switches
- 4 - Module connection CFW500-SFY2
- 5 - Slot for plugin
- 6 - Power connection
- 7 - Grounding points
- 8 - Braking resistor connection
- 9 - LED indicators
- 10 - Handle connection

Certifications





GREATER savings!



Space saving and flexible solution



Greater robustness



Reduced cable costs



Reduced installation costs



Easy commissioning



No panel required



+
space

-
costs

Up to
40%
cost
reduction

Connectivity



The MW500 can be interconnected to the main industrial communication networks, with worldwide protocols, such as CANopen, Profibus-DP, DeviceNet, PROFINET IO and EtherNet/IP, through plug-in modules.

Additionally, any plug-in module comes with a built-in RS485 Modbus-RTU / BACnet serial interface.

Remote operator interface (HMI) via HMI-01 accessory

Easy operation and view



I/O expansion:
IOS (standard, included in the version with plug-in), IOD, IOAD, IOR

Expansion of functionalities:
Incremental encoder
USB

Communication protocols:
Fieldbus
CANopen
DeviceNet
RS232
RS485
Profibus-DP
EtherNet/IP
Modbus-TCP
PROFINET IO

Selectable accessories

Free on the website www.weg.net

WPS software

USB connection (CFW500-CUSB accessory)

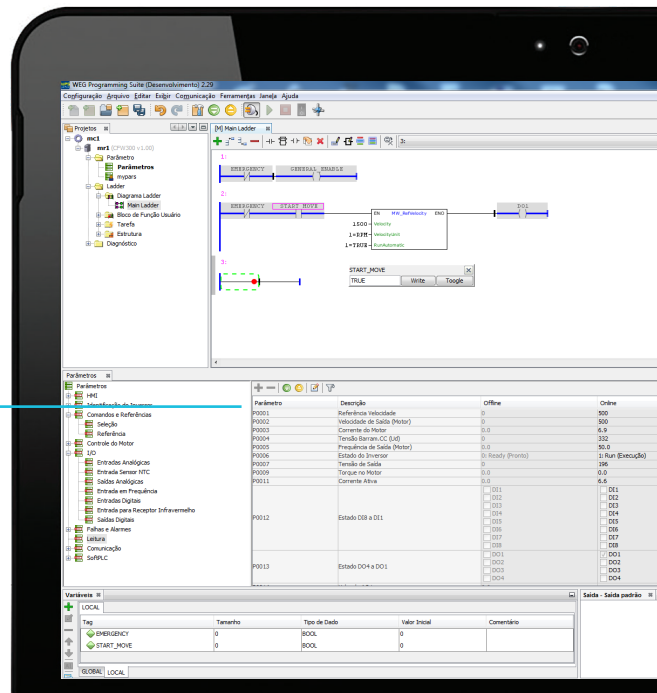
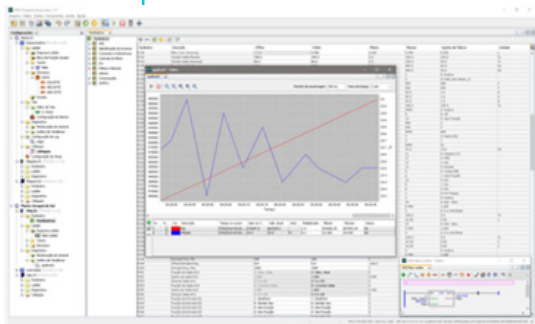

Features

- Special engineering units (RPM, °C, Nm, mA, %, kW, kWh, among others)
- Password to protect the setting
- Backup of all parameters
- Up to two different programs can be saved on the memory of the MW500
- Setting of the switching frequency according to the application requirements
- Speed reference via electronic potentiometer
- Multispeed with up to eight programmable speeds
- Slip compensation
- Manual or automatic torque boost (V/F scalar mode) and self-adjustment (vector modes and VVW)
- Acceleration/deceleration ramps
- Permanent magnet motor control: VVW PM
- “S” type ramp
- DC braking
- Built-in braking IGBT
- PID controller for process control with process variable feedback
- Flying start / Ride through
- Sleep mode
- Configurable avoided frequency or frequency ranges
- Overload and overtemperature protection
- Overcurrent protection
- DC link voltage supervision
- Fault log
- STO and SS1 safety functions (accessory)

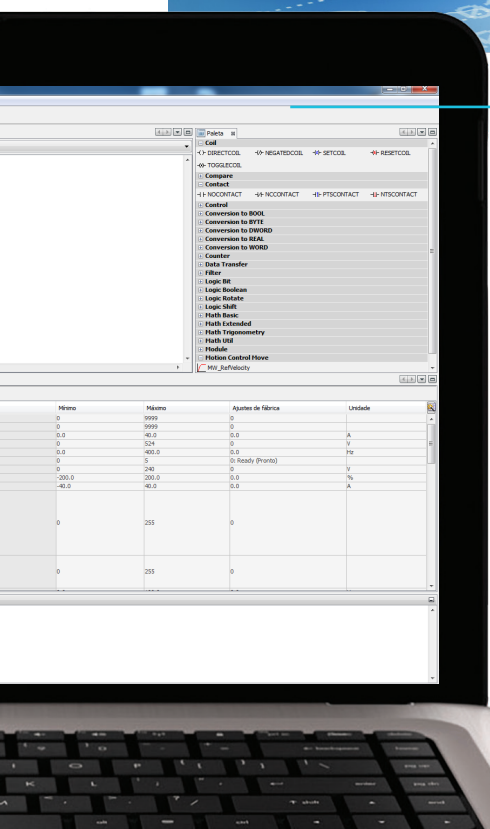

Easy and user-friendly environment

Free at www.weg.net

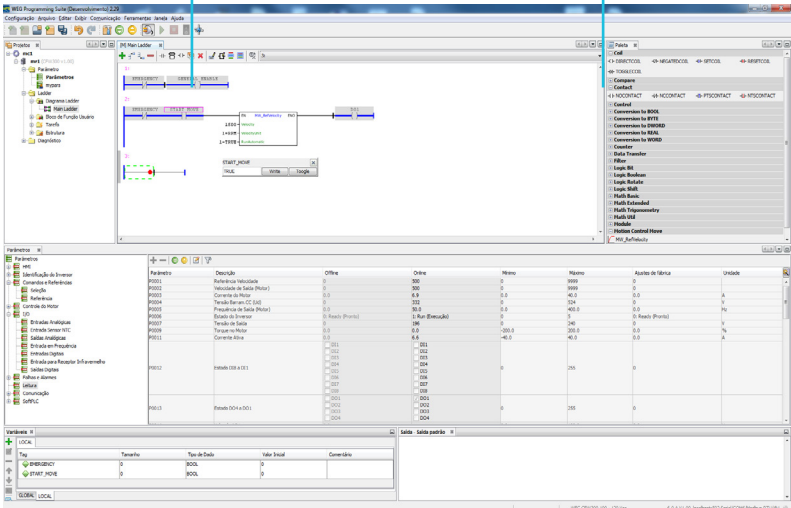

Built-in safety functions¹⁾

Safety functions are features used to reduce risks and protect people and equipment in the event of potentially dangerous failures in machines in operation. The built-in **STO** and **SS1** functions provide machine builders with a cost-effective solution for designing features to make machines comply with safety standards, reducing risks of unexpected and hazardous motions in machinery and industrial processes.

Advantages

- The MW500 safety features make it easier to meet machine safety requirements.
- Fewer components, no additional cabling required, saving space and installation costs.
- Easy installation, commissioning and maintenance.
- The absence of electromechanical components enables faster responses and a higher level of productivity.
- Due to SIL 3 safety level, the MW500 with safety functions does not require external safety relays for monitoring cables and emergency-stop pushbuttons.



Safety functions

STO (Safe Torque Off)

This function immediately switches off the inverter output to the motor, disconnecting the supply of torque generating power. The **STO** function is also used for preventing unexpected machine starts or for emergency stops, in compliance with stop category 0 (IEC 60204-1). It is applicable where the motor can be stopped soon enough by the load itself or when motor coasting is not safety-relevant.

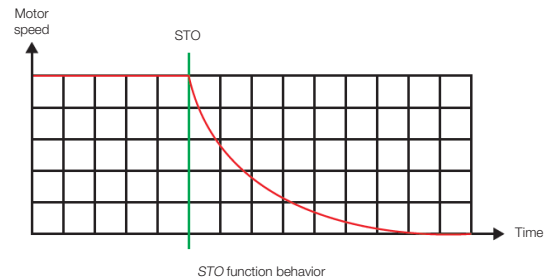

SS1 (Safe Stop 1)

The **SS1** function enables the motor deceleration ramp and, after the time set, automatically activates the **STO** function. It can be used to implement a controlled stop and then block the power supply to the motor, in compliance with stop category 1 according to IEC 60204-1.

This function is used when, in the event of a safety-related fault, the VFD must first stop the motor and then enter the **STO** state. A VFD stop using the **SS1** function reduces the risk of accidents and eliminates the need for external safety timers, increasing machine productivity and allowing safety distances on machines to be reduced. The reason is the active stop of the drive compared to the exclusive use of the **STO** function.

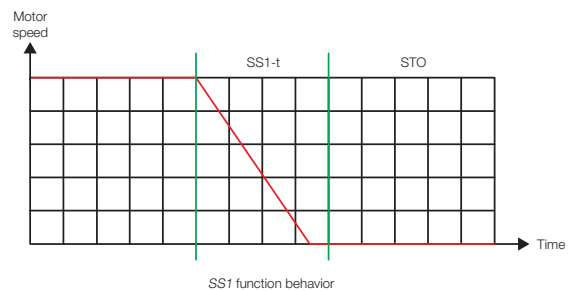

Note:

¹⁾ The **STO** and **SS1** safety functions are available on MW500 VFDs that contain G2 in the smart code. The CFW500-SFY2 plug-in is used as an accessory and is purchased separately. In compliance with SIL 3/PL safety performance requirements and with IEC 61800-5-2, EN ISO 13849-1, EN 62061, IEC 61508 and IEC 60204-1.

Applications

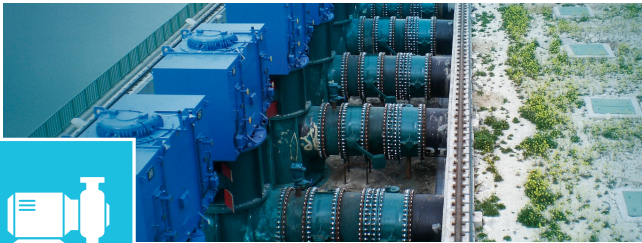

Pumps



Process pumps



Mixers / bottlers



Conveyor belts



Compressors

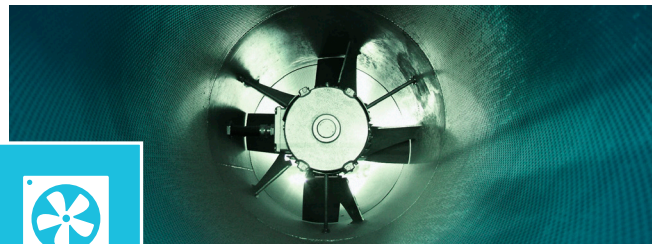

Fans / exhaust fans



Dryers / washing machines



General machinery

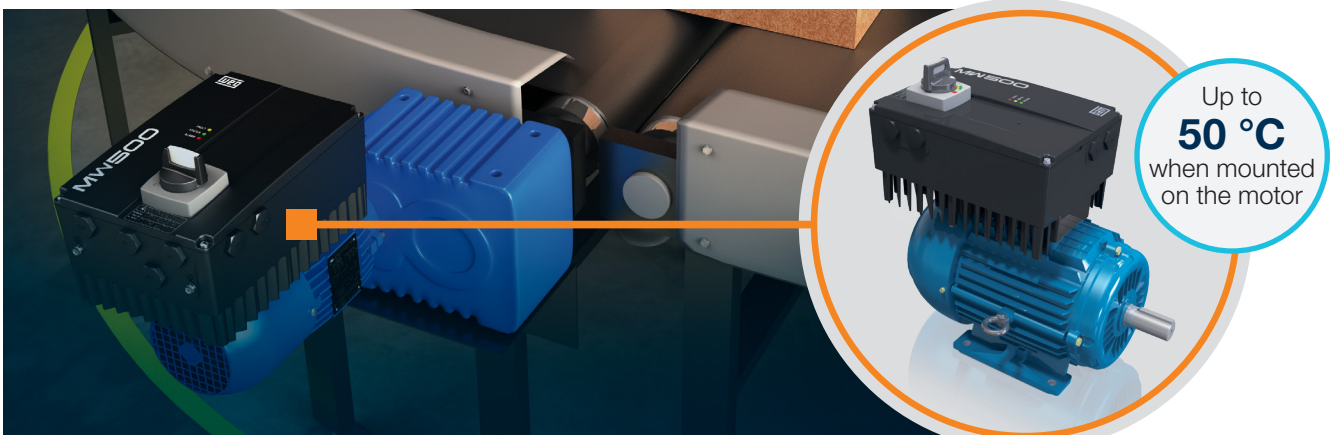

Up to **50 °C**
when mounted
on the motor

Special characteristics



Remote HMI

Simple and user-friendly



IP66/NEMA 4X connector

Special connector for remote HMI (M8) or external sensor



Cooling fins

No need for ventilation, reducing maintenance costs and noise

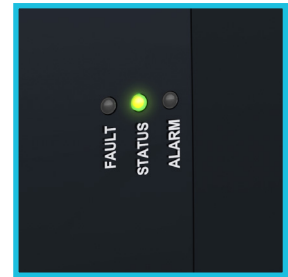

LED indicators

Programmable status indication



Internal analog potentiometer

No HMI required for operation



Built-in switch-disconnector (optional)

Easy and safe machine maintenance

Characteristics

Conformal coating

Standard Class 3C2 coating on the internal circuits of all versions, according to IEC 60721-3-3, guarantees more protection in environments with corrosive chemical agents.

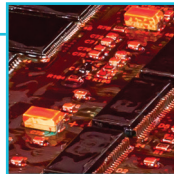

RFI filter

Category C2 or C3 to reduce the electromagnetic interference emission.

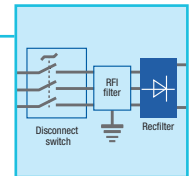

IP66/NEMA 4X protection rating

Essential for decentralized solutions, IP66 provides protection against contact with energized internal parts and ingress of dust or water.



Black

The black color increases the dissipation capacity of the housing, helping the VFD withstand up to 50 °C when mounted on the motor without current derating.



SoftPLC

Functions to streamline operation and increase performance, in many cases, eliminating the need for an external PLC, optimizing and simplifying the system.

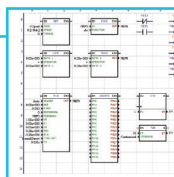

WPS

Free software for parameter configuration, and control and monitoring of the VFD, simulating an oscilloscope with the *Trend* function.

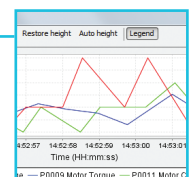

Coding¹⁾

- 1 MW500 2 A 3 02P6 4 T 5 4 6 DB 7 66 8 C2 9 DS 10 A56 11 12 --- 13 G2

- 1 - MW500 variable speed drive
- 2 - MW500 size according to table 1 below
- 3 - Rated output current according to table 1 below

Supply line	Single-phase (S)	Three-phase (T)
	200-240 V _{AC}	380-480 V _{AC}
Voltage	02P1 = 2.1 A 02P9 = 2.9 A 03P4 = 3.4 A 04P3 = 4.3 A 06P0 = 6.0 A	01P3 = 1.3 A 01P6 = 1.6 A 02P0 = 2.0 A 02P6 = 2.6 A 04P3 = 4.3 A 05P2 = 5.2 A 06P5 = 6.5 A 10P0 = 10.0 A 14P0 = 14.0 A 16P0 = 16.0 A

4 - Number of phases

S	Single-phase power supply
T	Three-phase power supply

5 - Rated voltage

2	200-240 V
4	380-480 V

6 - Internal dynamic braking²⁾

DB	With internal dynamic braking IGBT
----	------------------------------------

7 - Protection rating

66	IP66 (NEMA 4X) protection rating
----	----------------------------------

8 - Conducted emission level³⁾

Blank	Without internal RFI filter
C2	With internal RFI filter - category 2

9 - Switch-disconnector

Blank	Without switch-disconnector
DS	With switch-disconnector

10 - Terminal box⁴⁾

Blank	Motor connection box sizes 70 x 70 mm and 110 x 110 mm; applicable to frame C
A56	Motor connection box sizes 56 x 56 mm; applicable to frames A and B
A70	Motor connection box sizes 70 x 70 mm; applicable to frames A and B

11 - Special hardware versions - H xx

	Without plug-in module
--	------------------------

12 - Special software version - Sxx

Blank	Standard software
Sxx	Special software

13 - Generation

Blank	Generation 1
G2	Generation 2

Frames	Model	Output current	Input	Supply voltage
A	02P1	2.1 A	S = single-phase power supply	2 = 200...240 V
	02P9	2.9 A		
	03P4	3.4 A		
	04P3	4.3 A		
	06P0	6.0 A		
A	01P3	1.3 A	T = three-phase power supply	4 = 380...480 V
	01P6	1.6 A		
	02P0	2.0 A		
	02P6	2.6 A		
	04P3	4.3 A		
B	05P2	5.2 A		
	06P5	6.5 A		
	10P0	10.0 A		
C	14P0	14.0 A		
	16P0	16.0 A		

Notes:

1) Other configurations on request.

2) Braking resistor not included.

3) Conducted emission level (IEC 61800-3).

In order to minimize such problem, WEG variable speed drives contain common-mode capacitive filters, which are enough to avoid this type of interference in most cases.

If necessary, our VFDs also have radio frequency (RF) filters to reduce even more those high-frequency electromagnetic interference signals.

Definitions of IEC/EN 61800-3 standard.

Categories:

Category C1: variable speed drives with voltage rating below 1000 V and intended for application in the "First Environment".

Category C2: variable speed drives with voltage rating below 1000 V not provided with plugs or movable installations that, when applied in the "First Environment", must be installed and commissioned by a professional.

Category C3: variable speed drives with voltage ratings below 1000 V developed for application in the "Second Environment" and not designed for application in the "First Environment".

Environments: First Environment: environments that include domestic installations, such as establishments directly connected without intermediate transformers to the low voltage power line, which supplies buildings used for domestic purposes. Second environment: environments that include all the buildings other than those directly connected to the low voltage power line, which supplies buildings used for domestic purposes.

4) Frame C can use 70 mm and 110 mm box for connection; therefore, no specific code is required on the order for the 70 or 110 mm option.

Specifications

Specifications and models

MW500 variable frequency drive					Maximum applicable motor	
Reference	Supply voltage	Frame	Braking IGBT	Rated output current (A)	Motor Voltage	WEG Motor Power
						HP
Models						
MW500 without disconnecting switch and without RFI filter						
MW500A02P1S2DB66XXXG2	200-240	Single-phase	A	Internal included	3/230VAC	0.5
MW500A02P9S2DB66XXXG2						0.75
MW500A03P4S2DB66XXXG2						1
MW500A04P3S2DB66XXXG2						1.5
MW500A06P0S2DB66XXXG2						2
MW500A01P3T4DB66XXXG2	380-480	Three-phase	A	Internal included	3/460VAC	0.5
MW500A01P6T4DB66XXXG2						0.75
MW500A02P0T4DB66XXXG2						1
MW500A02P6T4DB66XXXG2						1.5
MW500A04P3T4DB66XXXG2						2
MW500B05P2T4DB66XXXG2			3			
MW500B06P5T4DB66XXXG2			5			
MW500B10P0T4DB66XXXG2			7.5			
MW500C14P0T4DB66G2			10			
MW500C16P0T4DB66G2			10			
MW500 without disconnecting switch and with RFI filter						
MW500A02P1S2DB66C2XXXG2	200-240	Single-phase	A	Internal included	3/230VAC	0.5
MW500A02P9S2DB66C2XXXG2						0.75
MW500A03P4S2DB66C2XXXG2						1
MW500A04P3S2DB66C2XXXG2						1.5
MW500A06P0S2DB66C2XXXG2						2
MW500A01P3T4DB66C2XXXG2	380-480	Three-phase	A	Internal included	3/460VAC	0.5
MW500A01P6T4DB66C2XXXG2						0.75
MW500A02P0T4DB66C2XXXG2						1
MW500A02P6T4DB66C2XXXG2						1.5
MW500A04P3T4DB66C2XXXG2						2
MW500B05P2T4DB66C2XXXG2			3			
MW500B06P5T4DB66C2XXXG2			5			
MW500B10P0T4DB66C2XXXG2			7.5			
MW500C14P0T4DB66C2G2			10			
MW500C16P0T4DB66C2G2			10			

Note:

- 1) The power ratings for the maximum applicable motor shown in the table above are reference values and valid for WEG motors. The powers indicated are based on WEG W22 Premium Efficiency, three-phase, four-pole induction motors with a 230V or 460V Power Supply. Proper sizing must always be determined according to the motor rated current, which must be less than or equal to the VFD rated output current. For further information, refer to the User Manual.
- 2) The "XXX" in the smart code must be filled in with A56 or A70, with the MW500 terminal box matching the motor terminal box. For more details, check the "Motor and Inverter Mechanical Assembly" tables to select the code according to the specified motor.
- 3) The current values are valid for mounting the MW500 VFD on a surface with an ambient temperature of 40°C or a self-ventilated motor with an ambient temperature of 50°C. For more information about installation on a motor at an ambient temperature of 40°C, see the user manual.



Specifications

Specifications and models

MW500 variable frequency drive					Maximum applicable motor		
Reference	Supply voltage	Frame	Braking IGBT	Rated output current (A)	Motor Voltage	WEG Motor Power	
							HP
Models							
MW500 with disconnecting switch and without RFI filter							
MW500A02P1S2DB66DSXXXG2	200-240	Single-phase	A	Internal included	2.1	3/230VAC	0.5
MW500A02P9S2DB66DSXXXG2					2.9		0.75
MW500A03P4S2DB66DSXXXG2					3.4		1
MW500A04P3S2DB66DSXXXG2					4.3		1.5
MW500A06POS2DB66DSXXXG2					6.0		2
MW500A01P3T4DB66DSXXXG2	380-480	Three-phase	A	Internal included	1.3	3/460VAC	0.5
MW500A01P6T4DB66DSXXXG2					1.6		0.75
MW500A02P0T4DB66DSXXXG2					2.0		1
MW500A02P6T4DB66DSXXXG2					2.6		1.5
MW500A04P3T4DB66DSXXXG2					4.3		2
MW500B05P2T4DB66DSXXXG2			5.2		3		
MW500B06P5T4DB66DSXXXG2			6.5		5		
MW500B10P0T4DB66DSXXXG2			10.0		7.5		
MW500C14P0T4DB66DSG2			14.0		10		
MW500C16P0T4DB66DSG2			16.0		10		
MW500 with disconnecting switch and with RFI filter							
MW500A02P1S2DB66C2DSXXXG2	200-240	Single-phase	A	Internal included	2.1	3/230VAC	0.5
MW500A02P9S2DB66C2DSXXXG2					2.9		0.75
MW500A03P4S2DB66C2DSXXXG2					3.4		1
MW500A04P3S2DB66C2DSXXXG2					4.3		1.5
MW500A06POS2DB66C2DSXXXG2					6.0		2
MW500A01P3T4DB66C2DSXXXG2	380-480	Three-phase	A	Internal included	1.3	3/460VAC	0.5
MW500A01P6T4DB66C2DSXXXG2					1.6		0.75
MW500A02P0T4DB66C2DSXXXG2					2.0		1
MW500A02P6T4DB66C2DSXXXG2					2.6		1.5
MW500A04P3T4DB66C2DSXXXG2					4.3		2
MW500B05P2T4DB66C2DSXXXG2			5.2		3		
MW500B06P5T4DB66C2DSXXXG2			6.5		5		
MW500B10P0T4DB66C2DSXXXG2			10.0		7.5		
MW500C14P0T4DB66C2DSG2			14.0		10		
MW500C16P0T4DB66C2DSG2			16.0		10		

Notes:

- 1) The power ratings for the maximum applicable motor shown in the table above are reference values and valid for WEG motors. The powers indicated are based on WEG W22 Premium Efficiency, three-phase, four-pole induction motors with a 230V or 460V Power Supply. Proper sizing must always be determined according to the motor rated current, which must be less than or equal to the VFD rated output current. For further information, refer to the User Manual.
- 2) The "XXX" in the smart code must be filled in with A56 or A70, with the MW500 terminal box matching the motor terminal box. For more details, check the "Motor and Inverter Mechanical Assembly" tables to select the code according to the specified motor.
- 3) The current values are valid for mounting the MW500 VFD on a surface with an ambient temperature of 40°C or a self-ventilated motor with an ambient temperature of 50°C. For more information about installation on a motor at an ambient temperature of 40°C, see the user manual.

Accessories

Plug-in modules

You can choose the plug-in module for the MW500 later. In this case, subsequent selection of a plug-in module according to the table below is necessary.

You must always use one plug-in module for the MW500.

Due to the different connections, when equipped with the plug-in module with the STO/SS1 safety functions, the VFD will still be able to connect another plug-in module.

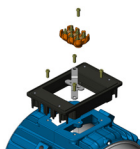
Reference	Description	Illustrative figures	
Input and output (I/O) expansion²			
CFW500-IOS ¹	Digital and analog input and output (I/O) plug-in module		
CFW500-IOD	Digital input and output (I/O) expansion plug-in module		
CFW500-IOAD	Digital and analog input and output (I/O) expansion plug-in module		
CFW500-IOR-B	Relay output expansion plug-in module		
Functionality expansion			
CFW500-ENC	Plug-in module with input for encoder		
CFW500-CUSB	Plug-in module with USB port		
CFW500-SFY2	Module with STO and SS1 safety functions		
Communication on Fieldbus networks			
CFW500-CCAN	CAN communication plug-in module (CANopen/DeviceNet)		
CFW500-CRS232	RS232 communication plug-in module		
CFW500-CRS485-B	RS485 communication plug-in module		
CFW500-CPDP2	Profibus-DP communication plug-in module		
CFW500-CETH-IP	EtherNet/IP communication plug-in module		
CFW500-CEMB-TCP	Modbus-TCP communication plug-in module		
CFW500-CEPN-IO	PROFINET IO communication plug-in module		
Memory			
CFW500-MMF	Flash memory module		
Interfaces			
CFW500-HMIR	Remote operator interface (HMI)		
HMI-01	Alphanumeric HMI		
CFW500-RHMIF	Remote HMI frame		
MW500-CCHMIR02M	Coiled Communication cable for connection of IP20 keypad via XC10 connector		
CFW500-CCHMIR01M	1-meter cable set for remote operator interface (HMI)		
CFW500-CCHMIR02M	2-meter cable set for remote operator interface (HMI)		
CFW500-CCHMIR03M	3-meter cable set for remote operator interface (HMI)		
CFW500-CCHMIR05M	5-meter cable set for remote operator interface (HMI)		
CFW500-CCHMIR075M	7,5-meter cable set for remote operator interface (HMI)		
CFW500-CCHMIR10M	10-meter cable set for remote operator interface (HMI)		
Kits			
MW500-KCFA-CL56	Adapter plate for wall mounting - Frame A and terminal box 56 x 56 mm		
MW500-KCFA-CL70	Adapter plate for wall mounting - Frame A and terminal box 70 x 70 mm		
MW500-KCFB-CL56	Adapter plate for wall mounting - Frame A and terminal box 56 x 56 mm		
MW500-KCFB-CL70	Adapter plate for wall mounting - Frame A and terminal box 70 x 70 mm		
MW500-KCFC	Adapter plate for the VFD wall mounting - Frame C		
MW500-KAIM-A56	Adapter plate for the VFD motor mounting - Frame A and terminal box 56 x 56 mm		
MW500-KAIM-A70	Adapter plate for the VFD motor mounting - Frame A and terminal box 70 x 70 mm		
MW500-KAIM-B56	Adapter plate for the VFD motor mounting - Frame B and terminal box 56 x 56 mm		
MW500-KAIM-B70	Adapter plate for the VFD motor mounting - Frame B and terminal box 70 x 70 mm		

Notes:

1) The "CFW500-IOS" module is included as standard with MW500 drives.

2) The plug-in modules are sold separately as an accessory item or spare part and replace the "CFW500-IOS" module which comes standard with drive.

Accessories

Plug-in module configuration ¹

Plug-in module	Functions																
	Inputs		Outputs			STO/SS1	USB port	Input for encoder ³	Fieldbus networks						Power supply		
	Digital	Analog	Analog	Digital relay	Digital transistor				CANopen DeviceNet	RS232	RS485	Profibus-DP	EtherNet/IP	Modbus-TCP	PROFINET IO	10 V	24 V
CFW500-IOS ⁵	4	1	1	1	1	-	-	-	-	-	1	-	-	-	-	1	1
CFW500-IOD	8	1	1	1	4	-	-	-	-	-	1	-	-	-	-	1	1
CFW500-IOAD	6	3	2	1	3	-	-	-	-	-	1	-	-	-	-	1	1
CFW500-IOR-B	5 ²	1	1	4	1	-	-	-	-	-	1	-	-	-	-	1	1
CFW500-ENC	5 ²	1	1	4	1	-	-	1	-	-	1	-	-	-	-	1	1
CFW500-CUSB	4	1	1	1	1	-	1	-	-	-	1	-	-	-	-	1	1
CFW500-SFY2 ⁴	-	-	-	-	-	2	-	-	-	-	-	-	-	-	-	-	-
CFW500-CCAN	2	1	1	1	1	-	-	-	1	-	1	-	-	-	-	1	-
CFW500-CRS232	2	1	1	1	1	-	-	-	-	1	1	-	-	-	-	-	1
CFW500-CRS485-B	4	2	1	2	1	-	-	-	-	-	2	-	-	-	-	1	1
CFW500-CPDP2	2	1	1	1	1	-	-	-	-	-	1	1	-	-	-	-	1
CFW500-CETH-IP	2	1	1	1	1	-	-	-	-	-	1	-	1	-	-	-	1
CFW500-CEMB-TCP	2	1	1	1	1	-	-	-	-	-	1	-	-	1	-	-	1
CFW500-CEPN-IO	2	1	1	1	1	-	-	-	-	-	1	-	-	-	1	-	1
CFW500-CETH2	2	1	-	-	1	-	-	-	-	-	1	-	1	1	-	-	-

Notes:

1) All plug-in module models have at least one RS485 port. The CFW500-CRS485 plug-in module has two RS485 ports.

The CFW500 allows the installation of one plug-in module per unit.

2) The DI5 input is always NPN, and it cannot be configured for PNP like the others.

3) Incremental Encoder (A/A - B/B).

See the installation guides of the plug-in modules on the website www.weg.net.

4) It enables the use with one more accessory on the same drive, due to its installation being on top of the product.

5) The CFW500-IOS module is included as standard with MW500 Drives

Step by step

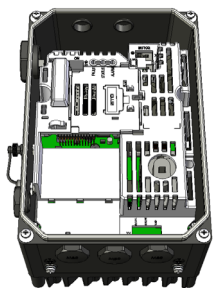

1 - Remove the cover

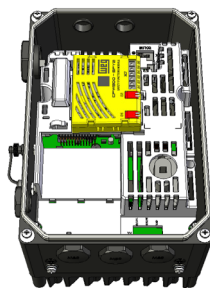

2 - Insert the accessory



3 - Close the cover

Simple!

Dimensions and weights

Version IP66/NEMA 4X

Frame	H	W	D1	D2	Weight
	mm [in]	mm [in]	mm [in]	mm [in]	kg [lb]
A	240 [9.45]	161.5 [6.36]	147.1 [5.79]	193.9 [7.63]	4.2 [9.3]
B	269 [10.61]	190 [7.48]	163.5 [6.44]	210.3 [8.28]	5.4 [11.9]
C	304.5 [12.0]	220.9 [8.7]	193.6 [7.62]	240.4 [9.46]	9.1 [20.1]

Note: VFD without wall mounting bracket.

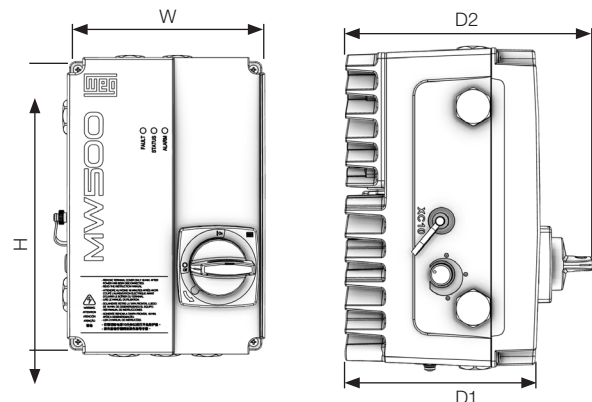

Motor and drive mechanical mounting combination¹⁾

Motor			NEMA dimensions																																					
Motor frame size	Motor terminal box mounting points/ MW500 mounting points (mm)	VFD housing size	2E	J	A	2F	B	BA	U	N-W	ES	S	R	S	D	HI	C	MA	MB	ØH	A'	H'	HD	L'																
NEMA (in)	143T	A	5.500	1.437	6.457	4.000	5.157	2.250	0.875	2.250	1.575	0.187	0.765	0.187	3.500	7.043	12.346	3.148	2.205	0.344	6.99	14.64	11.93	1.69																
		B																			8.1	15.32	12.62	2.83																
		L143T																			A	6.99	14.64	11.93	0.47															
																					B	8.1	15.32	12.62	1.61															
		145T																			A	5.000	6.142	2.250	0.875	2.250	1.575	0.187	0.765	0.187	3.500	7.043	13.346	3.640	2.205	0.344	6.99	14.64	11.93	1.69
																					B																8.1	15.32	12.62	2.2
	L145T	A	6.99	14.64	11.93	0.47																																		
		B	8.1	15.32	12.62	0.98																																		
	182T	A	7.500	1.594	8.661	4.500	5.945	2.750	1.125	2.750	1.969	0.250	0.984	0.250	4.500	8.883	14.860	3.608	2.756	0.406	6.99	16.57	13.86	0.445																
		B																			8.1	17.23	14.5	1.545																
		L182T																			A	6.99	16.57	13.86	-0.736															
																					B	8.1	17.23	14.5	0.364															
		184T																			A	6.969	2.750	1.125	2.750	1.969	0.250	0.984	0.250	4.500	8.974	15.860	4.093	2.756	0.406	6.99	16.57	13.86	-0.07	
																					B															8.1	17.23	14.5	1.03	
	L184T	A	6.99	16.57	13.86	-1.251																																		
		B	8.1	17.23	14.5	-0.151																																		
	213T	B	8.500	1.988	9.764	5.500	7.362	3.500	1.375	3.375	2.480	0.313	1.203	0.313	5.250	10.762	18.021	4.884	2.756	0.406	8.1	19.04	16.31	-0.09																
		C																			9.50	20.09	17.42	1.53																
		L213T																			B	8.1	19.04	16.31	-1.596															
																					C	9.50	20.09	17.42	0.024															
		215T																			B	7.000	8.858	3.500	1.375	3.375	2.480	0.313	1.203	0.313	5.250	10.762	19.517	5.634	2.756	0.406	8.1	19.04	16.31	0.65
																					C																9.50	20.09	17.42	0.01
	L215T	B	8.1	19.04	16.31	-0.738																																		
		C	9.50	20.09	17.42	-1.378																																		
254T	110x110 M8	C	10.000	2.539	12.126	8.252	10.000	4.250	1.625	4.000	2.456	0.375	1.406	0.375	6.250	12.746	23.213	6.076	4.331	0.531	9.50	22.07	19.41	-1.6																
		C				10.000	24.945										7.085	9.50			22.07	19.41	-2.6																	
		C				11.000	3.110										13.780	9.500			11.732	4.750	3.250	2.480	7.000	14.087	25.061	7.335	9.50	23.42	20.7	-3.2								
		C				1.875	4.622										3.149	0.500			1.594	0.500	26.433	9.50	23.42	20.7	-3.2													

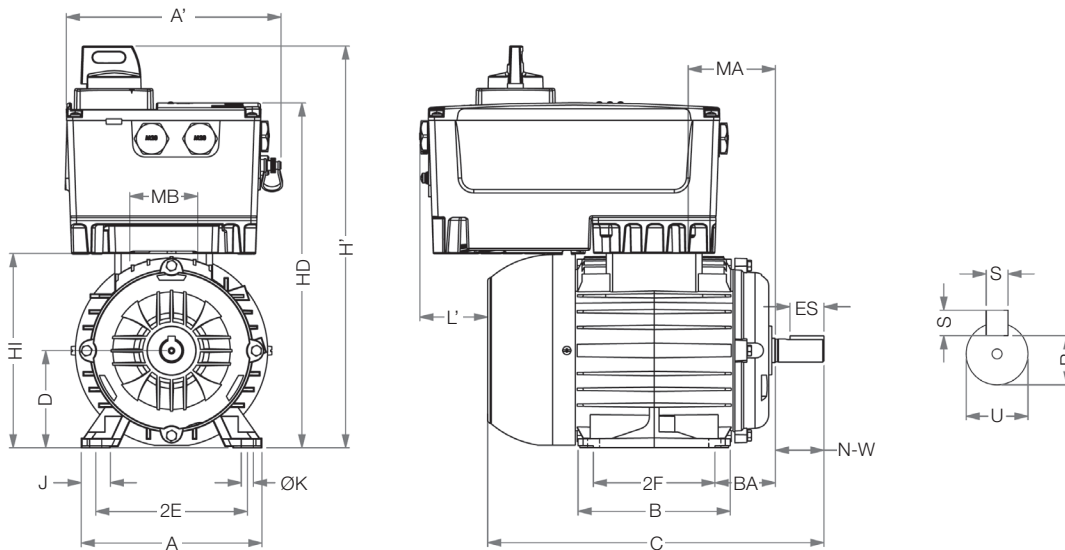

Note: 1) Dimensions considering the MW500 G2.

Motor and drive mechanical mounting combination

Motor		MW500																			IEC dimensions										
Motor frame size	Motor terminal box mounting points/ MW500 mounting points (mm)	VFD housing size	A	AA	AB	B	BB	C	D	E	ES	F	G	GD	H	HB	L	MA	MB	ØK	A'	H'	HD	L'							
70	56x56 M5x0.8	A	112	20	132	90	113.5	45	14	30	18	5	10	5	71	142	250	62	56	7	177.6	335	288	63							
80		A	125	30.5	149	100	125.5	50	19j6	40	28	6	15.5	6	80	160	276 325	72							78	10	206	391	344	72	
L80		A																													140
90S		A	160	40	188	173	63	28j6	60	45	24	100	200	376	420	105	70	12							206	483	436	-1			
L90S		B																											190	40.5	220
90L		A	216	45	248	178	225	89	38k6	80	63	10	33	8	132	272	490	515							155.5	110	240.9	512			
L90L		B																											216	45	248
100L		A	254	64	308	210	254	108	42k6	110	80	12	37	160	324	598	157.8	642							178.5	14.5	240.9	565			
L100L		B																											254	64	308
112M		A	254	64	308	210	254	108	42k6	110	80	12	37	160	324	598	157.8	642							178.5	14.5	240.9	565			
L112M	B	254																	64	308	210	254	108	42k6					110	80	12
132S	A		254	64	308	210	254	108	42k6	110	80	12	37	160	324	598	157.8	642							178.5	14.5	240.9	565			
L132S	B	254																	64	308	210	254	108	42k6					110	80	12
132M	A		254	64	308	210	254	108	42k6	110	80	12	37	160	324	598	157.8	642							178.5	14.5	240.9	565			
L132M	B	254																	64	308	210	254	108	42k6					110	80	12
132M/L	A		254	64	308	210	254	108	42k6	110	80	12	37	160	324	598	157.8	642							178.5	14.5	240.9	565			
L132M/L	B	254																	64	308	210	254	108	42k6					110	80	12
160M	A		254	64	308	210	254	108	42k6	110	80	12	37	160	324	598	157.8	642							178.5	14.5	240.9	565			
L160M	B	254																	64	308	210	254	108	42k6					110	80	12
160L	A		254	64	308	210	254	108	42k6	110	80	12	37	160	324	598	157.8	642							178.5	14.5	240.9	565			
L160L	B	254																	64	308	210	254	108	42k6					110	80	12

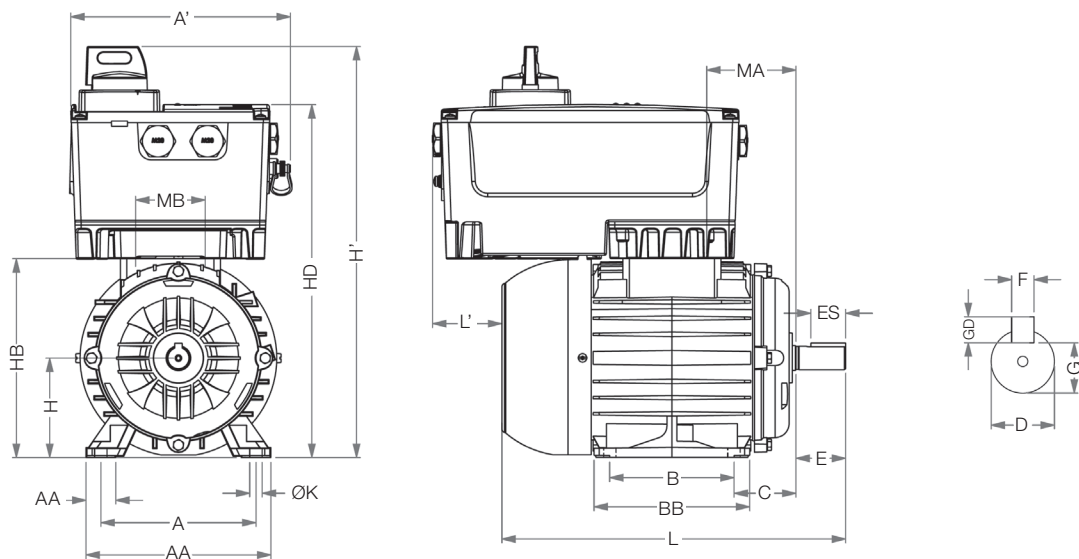

Standards

Standards	Safety standards	UL 61800-5-1: Adjustable Speed Electrical Drive Systems - Part 5-1.
		UL 840 - Insulation coordination including clearances and creepage distances for electrical equipment
		EN 61800-5-1 - Safety requirements electrical, thermal and energy
		EN 50178 - Electronic equipment for use in power installations
		EN 60204-1 - Safety of machinery. Electrical equipment of machines. Part 1: general requirements Note: In order to have a machine in accordance with this standard, the manufacturer of the machine is responsible for installing an emergency stop device and a device for disconnecting the power line.
		EN 60146 (IEC 146) - Semiconductor converters
		EN 61800-2 - Adjustable speed electrical power drive systems - Part 2: general requirements - Rating specifications for low voltage adjustable frequency AC power drive systems
	Electromagnetic compatibility standards	EN 61800-3 - Adjustable speed electrical power drive systems - Part 3: EMC product standard including specific test methods
		EN 55011 - Limits and methods of measurement of radio disturbance characteristics of industrial, scientific and medical (ISM) radio-frequency equipment
		CISPR 11 - Industrial, scientific and medical (ISM) radio-frequency equipment - Electromagnetic disturbance characteristics - Limits and methods of measurement
		EN 61000-4-2 - Electromagnetic compatibility (EMC) - Part 4: testing and measurement techniques - Section 2: electrostatic discharge immunity test
		EN 61000-4-3 - Electromagnetic compatibility - Part 4: testing and measurement techniques - Section 3: radiated, radio-frequency, electromagnetic field immunity test
		EN 61000-4-4 - Electromagnetic compatibility - Part 4: testing and measurement techniques - Section 4: electrical fast transient/burst immunity test
		EN 61000-4-5 - Electromagnetic compatibility - Part 4: testing and measurement techniques - Section 5: surge immunity test
	Mechanical construction standards	EN 61000-4-6 - Electromagnetic compatibility - Part 4: testing and measurement techniques - Section 6: immunity to conducted disturbances, induced by radio-frequency fields
		EN 60529 - Degrees of protection provided by enclosures (IP code)
		UL 50 - Enclosures for electrical equipment

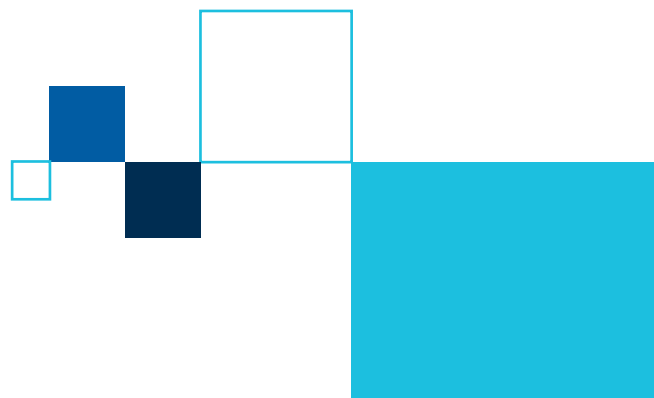

Technical data

Power	Power supply	Tolerance: -15 to +10% Frequency: 50/60 Hz (48 Hz to 62 Hz) Phase imbalance: ≤3% of the rated phase-phase input voltage Maximum of 10 (line) connections per hour (1 every 6 minutes) Typical efficiency: ≥97%
Control	Method	Control types: V/F (scalar) VW: voltage vector control Vector without encoder (sensorless) and vector with encoder VW PM: voltage vector control for permanent magnet motors
	Output frequency	0 to 500 Hz, resolution of 0.015 Hz
Performance	V/F control	Speed regulation: 1% of the rated speed (with sleep compensation) Speed variation range: 1:20
	Vector control (VW)	Speed regulation: 1% of the rated speed Speed variation range: 1:30
	Vector without encoder (sensorless)	Regulation: 0.5% of the rated speed Speed variation range: 1:100
	Vector with encoder	Regulation: ±0.01% of the rated speed Speed variation range: 1:100
	VW PM⁴⁾ control	Regulation: 0.1% of the rated speed Speed variation range: 1:20
Braking methods	Dynamic braking	Available as standard for frames A, B and C An external resistor must be used for dynamic braking capability
Environmental conditions	Temperature around the CFW500	-10 °C to 40 °C - for wall mounting -10 °C to 50 °C - for mounting using self-ventilated motor at rated speed 2% current derating for each degree Celsius above the operating temperature, limited to an increase of 10 °C
	Air relative humidity	5% to 95% non-condensing
	Altitude	Up to 1,000 m (maximum altitude under normal conditions) 1,000 to 4,000 m: current derating of 1% for each 100 m above 1,000 m of altitude From 2,000 to 4,000 m maximum voltage derating (380-480 V models) of 1.1% for every 100 meters above 2,000 m altitude
	Protection rating	IP66/NEMA 4X
Inputs¹⁾	Analog	1 isolated input Levels: (0 to 10) V or (0 to 20) mA or (4 to 20) mA Linearity error ≤0.25% Impedance: 100 kΩ for voltage input, 500 Ω for current input Programmable functions, including PTC input Maximum voltage accepted in the inputs: 30 V _{DC}
	Digital	4 isolated inputs Programmable functions: Active high (PNP): maximum low level 15 V _{DC} ; minimum high level 20 V _{DC} Active low (NPN): maximum low level 5 V _{DC} ; minimum high level 9 V _{DC} Maximum input voltage 30 V _{DC} Input current: 4.5 mA Max input current: 5.5 mA
Outputs¹⁾	Analog	1 isolated output Levels (0 to 10) V or (0 to 20) mA or (4 to 20) mA Linearity error ≤0.25% Programmable functions RL ≥10 kΩ (0 to 10 V) or RL ≤500 Ω (0 to 20 mA / 4 to 20 mA)
	Relay	1 relays with NO/NC contact Maximum voltage: 240 V _{AC} Maximum current 0.5 A Programmable functions
	Transistor	1 open sink isolated digital output (uses the 24 V _{DC} source as reference) Maximum current 150 mA (maximum source capacity 24 V _{DC}) ²⁾ Programmable functions
	Power supply	Power supply 24 V _{DC} Maximum capacity: 150 mA ³⁾ Power supply 10 V _{DC} Maximum capacity: 2 mA
Communication	Plug-in modules	Fieldbus: Modbus-RTU, CANopen, DeviceNet, Profibus-DP, EtherNet/IP, Modbus-TCP, PROFINET IO USB, RS485, and RS232
Safety	Protection	Overcurrent/phase-phase short circuit in the output Overcurrent/phase-ground short circuit in the output Under/overvoltage in the power Overtemperature on the heatsink Motor overload (1.5 x I _n (inverter) for 1 minute, every 10 minutes) ⁵⁾ Power module (IGBTs) overload External fault / alarm Setting error STO and SS1 safety functions (accessory)
Human machine interface (HMI)	CFW500-HMIR Accessory	9 keys: Run/Stop, Increment, Decrement, Direction of Rotation, Jog, Local/Remote, Back/Esc and Enter/Menu LCD display It allows accessing/changing all the parameters Precision of the indications: Current: 5% of the rated current Speed resolution: 0.1 Hz

Notes:

- 1) The number and/or types of analog/digital inputs/outputs may vary according to the plug-in module used. In the table above, the CFW500-IOS plug-in module was considered. For further information, refer to the module user manual.
- 2) The maximum capacity of 150 mA considers the load of the 24-V power supply plus the transistor output, that is, the sum of the consumption of both must not exceed 150 mA.
- 3) Designed for exclusive industrial or professional use.
- 4) The VW PM function is available for all VFDs with firmware version V3.XX or higher.
- 5) For the 0.37 kW and 0.55 kW models of the 380-480 V line, the overload capacity is 4 x I_n.

Block diagram

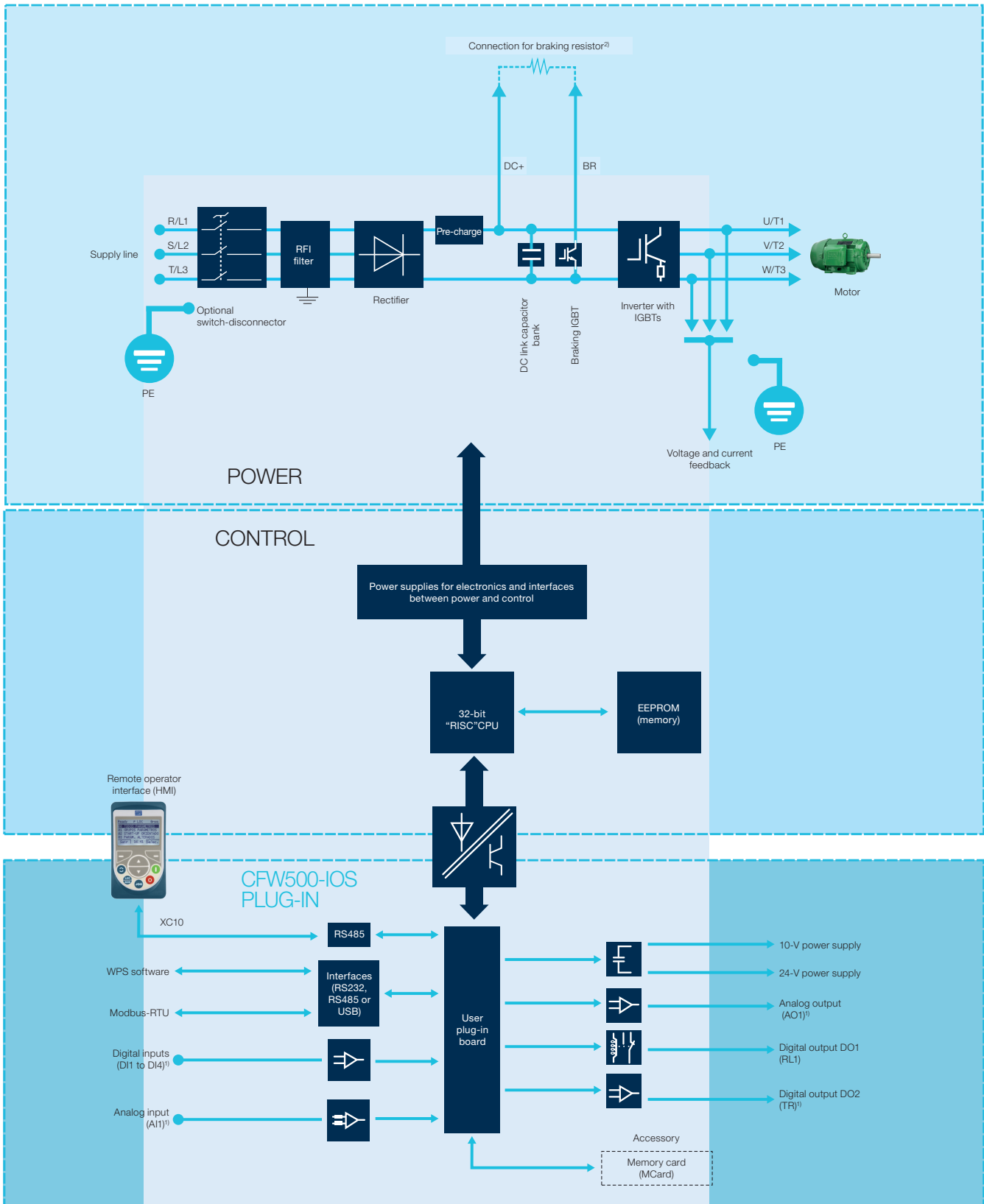

Notes:

- 1) The number of inputs and outputs (analog and digital), as well as other resources, may vary according to the plug-in module used. For further information, see the manual for the plug-in used.
- 2) Resistor not included. IGBT braking included across the entire MW500 line.

Global presence

is essential, as much as understanding your needs.

Global Presence

With more than 40,000 employees worldwide, WEG is one of the largest electric motors, electronic equipments and systems manufacturers. We are constantly expanding our portfolio of products and services with expertise and market knowledge. We create integrated and customized solutions ranging from innovative products to complete after-sales service.

WEG's know-how guarantees the **MW500 – Decentralized VFD – Motordrive** are the right choice for your application and business, assuring safety, efficiency and reliability.



Availability is to have a global support network



Partnership is to create solutions that suits your needs



Competitive edge is to unite technology and innovation

Know More

High performance and reliable products to improve your production process.

Excellence is to provide a whole solution in industrial automation that improves our customers productivity.

Visit:

www.weg.net



youtube.com/wegvideos



WEG's scope of solutions is not limited to the products and solutions presented in this brochure.

Contact WEG for information on additional products and solutions.

For WEG's worldwide operations visit our website



www.weg.net



 1-800-ASK-4WEG

 info-us@weg.net

 Duluth, GA