

Low Harmonic Regenerative Pump Controller U1000 iQpump MATRIX Drive User Manual

Type: CIMR-UW

Models: 200 V Class: 10 to 100 HP ND
400 V Class: 7.5 to 800 HP ND

To properly use the product, read this manual thoroughly and retain for easy reference, inspection, and maintenance. Ensure the end user receives this manual.

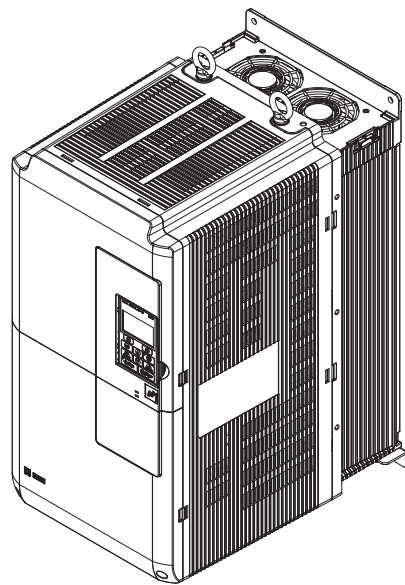

Receiving **1**

Mechanical Installation **2**

Electrical Installation **3**

Start-Up Programming & Operation **4**

Troubleshooting **5**

Periodic Inspection & Maintenance **6**

Peripheral Devices & Options **7**

Specifications **A**

Parameter List **B**

MEMOBUS/Modbus Communications **C**

Standards Compliance **D**

MANUAL NO. TOEPYAIUPW01C
PUBLISHED MARCH 2024
REVISION: <2>
DRIVE SOFTWARE PRG: 0030

This Page Intentionally Blank

Copyright © 2017 YASKAWA AMERICA, INC. All rights reserved.

No part of this publication may be reproduced, stored in a retrieval system, or transmitted, in any form or by any means, mechanical, electronic, photocopying, recording, or otherwise, without the prior written permission of Yaskawa. No patent liability is assumed with respect to the use of the information contained herein. Moreover, because Yaskawa is constantly striving to improve its high-quality products, the information contained in this manual is subject to change without notice. Every precaution has been taken in the preparation of this manual. Yaskawa assumes no responsibility for errors or omissions. Neither is any liability assumed for damages resulting from the use of the information contained in this publication.

Table of Contents

i. PREFACE & GENERAL SAFETY	11
i.1 Preface	12
Applicable Documentation.....	12
Symbols.....	12
Terms and Abbreviations	12
Trademarks	12
i.2 General Safety	13
Supplemental Safety Information	13
Safety Messages.....	14
General Application Precautions	16
Motor Application Precautions.....	18
Drive Label Warning Example.....	20
Warranty Information.....	20
1. RECEIVING	21
1.1 Section Safety	22
1.2 General Description	23
U1000 iQpump Model Selection.....	23
Control Mode Selection	23
1.3 Model Number and Nameplate Check	25
Nameplate	25
Model Number.....	28
1.4 Drive Models and Enclosures	30
Drive Models 2□0028 to 2□0248 and 4□0011 to 4□0930.....	30
Harmonic Filter Modules	31
1.5 Component Names	32
IP00/Open Type Enclosure	32
Harmonic Filter Modules	38
Front Views	39
2. MECHANICAL INSTALLATION	41
2.1 Section Safety	42
2.2 Mechanical Installation	44
Installation Environment	44
Installation Orientation and Spacing.....	45
Instructions on Installation Using the Eye Bolts and Hanging Brackets	47
HOA Keypad Remote Usage	50

Exterior and Mounting Dimensions	53
3. ELECTRICAL INSTALLATION	63
3.1 Section Safety.....	64
3.2 Standard Connection Diagram.....	66
Drive Models 2□0028 to 2□0248 and 4□0011 to 4□0590.....	67
Drive Models 4□0720 to 4□0930	69
3.3 Main Circuit Connection Diagram.....	71
Drive Models 2□0028 to 2□0248 and 4□0011 to 4□0590.....	71
Drive Models 4□0720 to 4□0930 and Harmonic Filter Modules	71
3.4 Terminal Block Configuration	72
Drive Models 2□0028 to 2□0248 and 4□0011 to 4□0930.....	72
Harmonic Filter Module	76
3.5 Terminal Cover	77
Models 2□0028 to 2□0130 and 4□0011 to 4□0124	77
Models 2□0154 to 2□0248 and 4□0156 to 4□0930	78
3.6 HOA Keypad and Front Cover.....	80
Removing/Reattaching the HOA Keypad	80
Removing/Reattaching the Front Cover	80
3.7 Top Protective Cover	83
Attaching the Top Protective Cover.....	83
Removing the Top Protective Cover	83
3.8 Main Circuit Wiring.....	84
Main Circuit Terminal Functions	84
Protecting Main Circuit Terminals	85
Main Circuit Wire Gauges and Tightening Torque	86
Main Circuit Terminal and Motor Wiring	92
3.9 Control Circuit Wiring	94
Control Circuit Connection Diagram.....	94
Control Circuit Terminal Block Functions	94
Wiring the Control Circuit Terminal	97
Module Communications Connector	99
Switches and Jumpers on the Terminal Board.....	101
3.10 Control I/O Connections	102
Sinking/Sourcing Mode for Digital Inputs	102
Terminals A1, A2, and A3 Input Signal Selection.....	103
Terminal AM/FM Signal Selection	106
MEMOBUS/Modbus Termination	106
Terminal A2 Input Signal Selection	106
3.11 Connect to a PC.....	107
3.12 Wiring Checklist	108
4. START-UP PROGRAMMING & OPERATION	111
4.1 Drive Start-Up Preparation	112
Start-Up Checklist	112
4.2 Powering Up the Drive	114
Setting the Real Time Clock.....	114
4.3 Application Selection	117

4.4	Using the HOA Keypad	118
	HOA Keypad Keys and Displays	118
	LCD Display	119
	ALARM (ALM) LED Displays.....	120
	AUTO LED and HAND LED Indications	120
	Menu Structure for HOA Keypad.....	122
	Changing Parameter Settings or Values	123
4.5	Pump Application Presets	125
	Modified Parameters Depending on A1-03 Setting	125
	Pump Quick Setup Menu Depending on A1-06 Setting	127
4.6	U1000 iQpump Presets and Functions	128
	Pump Down Level Control Application Preset.....	128
	Suction Control via Constant Pressure w/Well Draw Down	130
	General Purpose Mode Application Preset	131
	Well Draw Down Control Application Preset	133
	Low City or Low Suction Inlet Pressure.....	136
	Water Level / Suction Pressure Control	138
	Delta Data Entry	138
	Current Limit.....	139
	Vertical Turbine Controller (VTC).....	140
	Pre-Charge Function with One Lag Pump	143
	Setpoint Boost after Lag Pump De-staging	146
	Frequency Reduction after Lag Pump Staging	147
	Using the DO-A3 Option for Additional Lag Pumps	148
	De-Scale/De-Ragging	149
	Flow Rate Limiter	151
	Multi-function Digital Input On/Off Time Delay	156
	PI Auxiliary Control.....	156
	Hybrid Sequence Control	161
	Differential Level Detection	162
4.7	Basic U1000 iQpump Setup and Application Preset Parameters	163
4.8	Test Run with No Load.....	199
	No-Load Operation Test Run	199
4.9	Test Run with Load Connected.....	200
	Test Run with the Load Connected	200
5.	TROUBLESHOOTING.....	201
5.1	Motor Performance Fine-Tuning	202
	Fine-Tuning V/f Control	202
	Fine-Tuning Open Loop Vector Control	202
5.2	Drive Alarms, Faults, Errors, and Messages	204
	Types of Alarms, Faults, and Errors.....	204
5.3	Fault Detection	205
	Fault Displays, Causes, and Possible Solutions	205
5.4	Alarm Detection	222
	Alarm Codes, Causes, and Possible Solutions	222
5.5	Operator Programming Errors	236
	Operator Programming Error Codes, Causes, and Possible Solutions.....	236
5.6	Auto-Tuning Fault Detection	240

Table of Contents

Auto-Tuning Codes, Causes, and Possible Solutions	240
5.7 Copy Function Related Displays	243
Tasks, Errors, and Troubleshooting	243
5.8 HOA Keypad Display Messages	245
Fault Reset Methods	246
5.9 Auto-Tuning	247
Types of Auto-Tuning	247
Auto-Tuning Interruption and Fault Codes	248
Auto-Tuning Operation Example	248
6. PERIODIC INSPECTION & MAINTENANCE	251
6.1 Section Safety	252
6.2 Inspection	254
Recommended Daily Inspection	254
Recommended Periodic Inspection	255
6.3 Periodic Maintenance	257
Replacement Parts	257
6.4 Drive Cooling Fans	259
Number of Cooling Fans	259
Cooling Fan Component Names	260
Drive Cooling Fan Replacement: Models 2□0028 to 2□0130 and 4□0011 to 4□0124	263
Drive Cooling Fan Replacement: Models 2□0154, 2□0192, 4□0156, and 4□0180	265
Drive Cooling Fan Replacement: Models 2□0248 and 4□0216 to 4□0414	269
Installing the Cooling Fan	271
Drive Cooling Fan Replacement: Models 4□0477 and 4□0590	274
Drive Cooling Fan Replacement: Models 4□0720 to 4□0930	278
Harmonic Filter Module Cooling Fan Replacement	283
6.5 Drive Replacement	288
Replacing the Drive	288
7. PERIPHERAL DEVICES & OPTIONS	291
7.1 Section Safety	292
7.2 Drive Options and Peripheral Devices	294
7.3 Connecting Peripheral Devices	295
Drive Models 2□0028 to 2□0248 and 4□0011 to 4□0590	295
Drive Models 4□0720 to 4□0930	296
7.4 Option Installation	297
Prior to Installing the Option	297
Communication Option Installation Example	298
7.5 Installing Peripheral Devices	301
Installing a Molded Case Circuit Breaker (MCCB) or Ground Fault Circuit Interrupter (GFCI)	301
Installing a Magnetic Contactor at the Power Supply Side	301
Connecting a Surge Absorber	302
Reducing Noise	302
Attachment for External Heatsink Mounting (IP00 Enclosure)	302
Installing a Motor Thermal Overload (oL) Relay on the Drive Output	302
A. SPECIFICATIONS	305

A.1	Power Ratings	306
	Three-Phase 200 V Class Drive Models 2□0028 to 2□0081	306
	Three-Phase 200 V Class Drive Models 2□0104 to 2□0248	307
	Three-Phase 400 V Class Drive Models 4□0011 to 4□0077	308
	Three-Phase 400 V Class Drive Models 4□0096 to 4□0414	309
	Three-Phase 400 V Class Drive Models 4□0477 to 4□0930	310
A.2	Drive Specifications	311
A.3	Drive Watt Loss Data	313
	Drive Models 2□0028 to 2□0248	313
	Drive Models 4□0011 to 4□0930	313
	Harmonic Filter Modules for Drive Models 4□0720 to 4□0930	314
A.4	Drive Derating Data	315
	Rated Current Depending on Carrier Frequency	315
	Carrier Frequency Derating	316
	Temperature Derating	316
	Altitude Derating	317
B.	PARAMETER LIST	319
B.1	Understanding Parameter Descriptions	320
	Control Modes, Symbols, and Terms	320
B.2	A: Initialization Parameters	321
	A1: Initialization	321
	A2: User Parameters	322
B.3	b: Application	323
	b1: Operation Mode Selection	323
	b2: DC Injection Braking	324
	b3: Speed Search	324
	b4: Timer Function	326
	b5: PID Control	326
	b6: Dwell Function	328
	b8: Energy Saving	328
B.4	C: Tuning	330
	C1: Acceleration and Deceleration Times	330
	C2: S-Curve Characteristics	330
	C3: Slip Compensation	331
	C4: Torque Compensation	331
	C6: Carrier Frequency	332
	C7: Voltage Adjustment	332
B.5	d: Reference Settings	333
	d1: Frequency Reference	333
	d2: Frequency Upper/Lower Limits	334
	d3: Jump Frequency	334
	d4: Frequency Reference Hold and Up/Down 2 Function	335
B.6	E: Motor Parameters	336
	E1: V/f Pattern for Motor 1	336
	E2: Motor 1 Parameters	337
B.7	F: Option Settings	338
	F4: Analog Monitor Card Settings (AO-A3)	338
	F5: Digital Output Card Settings (DO-A3)	338

F6: Communication Option Card Settings	339
F7: Communication Option Card Settings (SI-EM3, SI-EN3, SI-EP3)	341
B.8 H Parameters: Multi-Function Terminals	344
H1: Multi-Function Digital Inputs	344
H2: Multi-Function Digital Outputs	348
H3: Multi-Function Analog Inputs	352
H4: Analog Outputs	354
H5: MEMOBUS/Modbus Serial Communication	355
H6: Pulse Train Input	356
B.9 L: Protection Function	358
L1: Motor Protection	358
L2: Momentary Power Loss Ride-Thru	358
L3: Stall Prevention	359
L4: Speed Detection	360
L5: Fault Restart	361
L6: Torque Detection	362
L7: Torque Limit	363
L8: Drive Protection	363
L9: Drive Protection 2	364
B.10 n: Special Adjustments	365
n1: Hunting Prevention	365
n2: Speed Feedback Detection Control (AFR) Tuning	365
n3: Overexcitation Braking	365
n6: Online Tuning	365
B.11 o: Operator-Related Settings	366
o1: HOA Keypad Display Selection	366
o2: HOA Keypad Keypad Functions	367
o3: Copy Function	368
o4: Maintenance Monitor Settings	368
B.12 P: Pump Parameters	369
P1: Pump Basic	369
P2: Pump Protection	371
P3: Contactor Multiplexing	373
P4: Pump Advanced	375
P5: Pump HAND Mode	378
P6: Flow Meter Setup	379
P7: Anti-Jam	382
P8: De-Scale / De-Ragging	383
B.13 Q: PID Controller Parameters	384
Q1: Preset Setpoint	384
Q3: Output Current Limit	384
Q4: Water Level Control	384
Q5: Suction Pressure Control	386
Q6: PI Auxiliary Control	388
B.14 S: Special Application	392
S1: Dynamic Noise Control Function	392
S2: Programmable Run Timers	392
S6: Protection	395
B.15 T: Motor Tuning	396
T1: Induction Motor Auto-Tuning	396

B.16 U: Monitors	397
U1: Operation Status Monitors	397
U2: Fault Trace.....	400
U3: Fault History.....	402
U4: Maintenance Monitors	403
U5: PID Monitors	405
U6: Operation Status Monitors	406
U9: Power Monitors.....	406
B.17 Parameter Default Values Changed by Control Mode	408
B.18 V/f Pattern Default Values	409
B.19 Defaults by Drive Model	410
C. MEMOBUS/MODBUS COMMUNICATIONS	415
C.1 MEMOBUS/Modbus Configuration	416
C.2 Communication Specifications	417
C.3 Connecting to a Network	418
Network Cable Connection.....	418
Wiring Diagram for Multiple Connections	419
Network Termination	420
C.4 MEMOBUS/Modbus Setup Parameters	421
MEMOBUS/Modbus Serial Communication.....	421
C.5 Drive Operations by MEMOBUS/Modbus	425
Observing the Drive Operation.....	425
Controlling the Drive.....	425
C.6 Communications Timing	426
Command Messages from Master to Drive.....	426
Response Messages from Drive to Master	426
C.7 Message Format	427
Message Content	427
Slave Address	427
Function Code	427
Data.....	427
Error Check	427
C.8 Message Examples	429
Reading Drive MEMOBUS/Modbus Register Contents	429
Loopback Test.....	429
Writing to Multiple Registers.....	430
C.9 MEMOBUS/Modbus Data Table	431
Command Data	431
Monitor Data.....	432
Broadcast Messages	445
Fault Trace Contents.....	445
Alarm Register Contents	447
C.10 Enter Command	449
Enter Command Types	449
C.11 Communication Errors	450
MEMOBUS/Modbus Error Codes.....	450
Slave Not Responding.....	450

C.12 Self-Diagnostics	451
D. STANDARDS COMPLIANCE	453
D.1 Section Safety.....	454
D.2 UL Standards	456
UL Standards Compliance	456
Drive Motor Overload Protection	467

Preface & General Safety

This section provides safety messages pertinent to this product that, if not heeded, may result in fatality, personal injury, or equipment damage. Yaskawa is not responsible for the consequences of ignoring these instructions.

i.1	PREFACE.....	12
i.2	GENERAL SAFETY.....	13

i.1 Preface

Yaskawa manufactures products used as components in a wide variety of industrial systems and equipment. The selection and application of Yaskawa products remain the responsibility of the equipment manufacturer or end user. Yaskawa accepts no responsibility for the way its products are incorporated into the final system design. Under no circumstances should any Yaskawa product be incorporated into any product or design as the exclusive or sole safety control. Without exception, all controls should be designed to detect faults dynamically and fail safely under all circumstances. All systems or equipment designed to incorporate a product manufactured by Yaskawa must be supplied to the end user with appropriate warnings and instructions as to the safe use and operation of that part. Any warnings provided by Yaskawa must be promptly provided to the end user. Yaskawa offers an express warranty only as to the quality of its products in conforming to standards and specifications published in the Yaskawa manual. **NO OTHER WARRANTY, EXPRESS OR IMPLIED, IS OFFERED.** Yaskawa assumes no liability for any personal injury, property damage, losses, or claims arising from misapplication of its products.

This manual is designed to ensure correct and suitable application of U1000 iQpump drives. Read this manual before attempting to install, operate, maintain, or inspect a drive and keep it in a safe, convenient location for future reference. Be sure you understand all precautions and safety information before attempting application.

◆ Applicable Documentation

The following manuals are available for U1000 iQpump series drives:

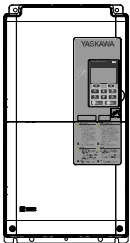
	U1000 iQpump Matrix Drive TOEPYAIUPW02 Quick Start Procedure
	Read this guide first. This guide is packaged together with the product and contains basic safety information, wiring information, and a list of models. Use this guide for basic settings and trial operation. The most recent version of this manual is available for download on our documentation website, www.yaskawa.com .
	U1000 iQpump Matrix Drive TOEPYAIUPW01 User Manual
	This manual contains information required to install and wire the drive, and gives an overview of fault diagnostics, maintenance safety, and parameter settings. The most recent version of this manual is available for download on our documentation website, www.yaskawa.com . Contact a Yaskawa representative to obtain a printed and bound version of the manual.

◆ Symbols

Note: Indicates a supplement or precaution that does not cause drive damage.

◆ Terms and Abbreviations

- **Drive:** Yaskawa U1000 iQpump Matrix Drive
- **BCD:** Binary coded decimal
- **H:** Hexadecimal number format
- **Harmonic Filter Module:** Standard configuration device harmonic filter module
- **IGBT:** Insulated Gate Bipolar Transistor
- **kbps:** Kilobits per Second
- **MAC:** Media Access Control
- **Mbps:** Megabits per Second
- **OLV:** Open Loop Vector Control
- **r/min:** Revolutions per Minute
- **V/f:** V/f Control

◆ Trademarks

- DeviceNet is a trademark of Open DeviceNet Vendor Association, Inc. (ODVA).
- EtherNet/IP is a trademark of Open DeviceNet Vendor Association, Inc. (ODVA).
- Modbus is a trademark of Schneider Electric.
- PROFIBUS-DP is a trademark of PROFIBUS International (PI).
- PROFNET is a trademark of PROFIBUS International (PI).
- Other companies and product names mentioned in this manual are trademarks of those companies.

i.2 General Safety

◆ Supplemental Safety Information

General Precautions

- The diagrams in this manual may be indicated without covers or safety shields to show details. Replace the covers or shields before operating the drive and run the drive according to the instructions described in this manual.
- Any illustrations, photographs, or examples used in this manual are provided as examples only and may not apply to all products to which this manual is applicable.
- The products and specifications described in this manual or the content and presentation of the manual may be changed without notice to improve the product and/or the manual.
- When ordering a new copy of the manual due to damage or loss, contact Yaskawa or a Yaskawa representative and provide the manual number shown on the front cover.
- If nameplate becomes worn or damaged, order a replacement from Yaskawa or a Yaskawa representative.

WARNING

Read and understand this manual before installing, operating or servicing this drive. The drive must be installed according to this manual and local codes.

The following conventions are used to indicate safety messages in this manual. Failure to heed these messages could result in serious or fatal injury or damage to the products or to related equipment and systems.

DANGER

Indicates a hazardous situation, which, if not avoided, will result in death or serious injury.

WARNING

Indicates a hazardous situation, which, if not avoided, could result in death or serious injury.

WARNING! *may also be indicated by a bold key word embedded in the text followed by an italicized safety message.*

CAUTION

Indicates a hazardous situation, which, if not avoided, could result in minor or moderate injury.

CAUTION! *may also be indicated by a bold key word embedded in the text followed by an italicized safety message.*

NOTICE

Indicates a property damage message.

NOTICE: *may also be indicated by a bold key word embedded in the text followed by an italicized safety message.*

◆ Safety Messages

DANGER

Heed the safety messages in this manual.

Failure to comply will result in death or serious injury.

The operating company is responsible for any injuries or equipment damage resulting from failure to heed the warnings in this manual.

Electrical Shock Hazard

Before servicing, disconnect all power to the equipment.

The output terminals remain charged even after the power supply is turned off. The charge indicator LED will extinguish when the control circuit DC voltage is below 50 Vdc. To prevent electric shock, wait for at least the time specified on the warning label, once all indicators are OFF, measure for unsafe voltages to confirm the drive is safe prior to servicing.

Failure to comply will result in death or serious injury.

WARNING

Sudden Movement Hazard

System may start unexpectedly upon application of power, resulting in death or serious injury.

Clear all personnel from the drive, motor and machine area before applying power. Secure covers, couplings, shaft keys and machine loads before applying power to the drive.

Electrical Shock Hazard

Do not attempt to modify or alter the drive in any way not explained in this manual.

Failure to comply could result in death or serious injury.

Yaskawa is not responsible for any modification of the product made by the user. This product must not be modified.

Do not allow unqualified personnel to use equipment.

Failure to comply could result in death or serious injury.

Installation, maintenance, inspection, and service must be performed only by authorized personnel familiar with installation, adjustment and maintenance of AC drives.

Do not remove covers or touch circuit boards while the power is on.

Failure to comply could result in death or serious injury.

Make sure the protective earthing conductor complies with technical standards and local safety regulations.

Because the leakage current exceeds 3.5 mA in models 4□0302 and larger, IEC/EN 61800-5-1:2007 states that either the power supply must be automatically disconnected in case of discontinuity of the protective earthing conductor or a protective earthing conductor with a cross-section of at least 10 mm² (Cu) or 16 mm² (Al) must be used. Failure to comply may result in death or serious injury.

Always use appropriate equipment for Ground Fault Circuit Interrupters (GFCIs).

The drive can cause a residual current with a DC component in the protective earthing conductor. Where a residual current operated protective or monitoring device is used for protection in case of direct or indirect contact, always use a type B GFCI according to IEC/EN 60755.

⚠ WARNING**Fire Hazard****Do not use an improper voltage source.**

Failure to comply could result in death or serious injury by fire. Verify that the rated voltage of the drive matches the voltage of the incoming power supply before applying power.

Do not use improper combustible materials.

Failure to comply could result in death or serious injury by fire. Attach the drive to metal or other noncombustible material.

Tighten all terminal screws to the specified tightening torque.

Loose electrical connections could result in death or serious injury by fire due to overheating of electrical connections.

Install adequate branch circuit protection according to applicable local codes and this manual. Failure to comply could result in fire and damage to the drive or injury to personnel.

The device is suitable for use on a circuit capable of delivering not more than 100,000 RMS symmetrical amperes, 240 Vac maximum (200 V class), and 500 Vac maximum (400 V class: 4A□□□□) when protected by branch circuit protection devices specified in this document.

Crush Hazard**Do not use this drive in lifting applications without installing external safety circuitry to prevent accidental dropping of the load. The drive does not possess built-in load drop protection for lifting applications.**

Failure to comply could result in death or serious injury from falling loads.

Install electrical and/or mechanical safety circuit mechanisms independent of drive circuitry.

⚠ CAUTION**Crush Hazard****Do not carry the drive by the front cover.**

Failure to comply may result in minor or moderate injury from the main body of the drive falling.

NOTICE**Observe proper electrostatic discharge procedures (ESD) when handling the drive and circuit boards. Failure to comply may result in ESD damage to the drive circuitry.****Do not do a withstand voltage test or use a megohmmeter or megger insulation tester on the drive.**

Failure to comply could result in damage to the sensitive devices within the drive.

Do not operate damaged equipment.

Failure to comply could result in further damage to the equipment. Do not connect or operate any equipment with visible damage or missing parts.

If a fuse is blown or a Ground Fault Circuit Interrupter (GFCI) is tripped, check the wiring and the selection of the peripheral devices.

Check for short circuits or ground faults on the secondary side of fuses and GFCIs and check the wiring and the selection of peripheral devices. Remove the cause of the problem and then turn the power supply off and on again. If the cause cannot be identified, do not turn on the power supply or attempt to operate the equipment.

Do not restart the drive immediately operate the peripheral devices if a fuse is blown or a GFCI is tripped.

Check the wiring and the selection of peripheral devices to identify the cause. Contact Yaskawa or a Yaskawa representative before restarting the drive or the peripheral devices if the cause cannot be identified.

Do not expose the drive to halogen group disinfectants.

Failure to comply may cause damage to the electrical components in the drive.

Do not pack the drive in wooden materials that have been fumigated or sterilized. Do not sterilize the entire package after the product is packed.

◆ General Application Precautions

■ Selection

Drive Rated Output Current

Make sure that the motor rated current is less than the rated output current for the drive.

When 2 Seconds is Required for Momentary Power Loss Ride-Thru Time

Use the units listed below when continuing drive operation after the power is restored even after a momentary loss of power of 2 seconds occurs:

- 200 V class Momentary Power Loss Ride-Thru unit: Model no. P0010
- 400 V class Momentary Power Loss Ride-Thru unit: Model no. P0020

Drive Start-Up Time

The drive requires 1.5 seconds to prepare for operation after the power is turned on. Be mindful of this delay when using an external reference input.

Note: 1.5 seconds is the required time when no optional devices are used with the drive. When using an optional communication device, the time required for the drive to be ready for operation will vary in accordance with the start up time of the communication card.

Selection of Power Supply Capacity

Use a power supply greater than the rated input capacity (kVA) of the drive. If the power supply is lower than the rated capacity of the drive, the device will be unable to run the application properly and will trigger a fault.

The rated input capacity of the drive, S_{CONV} (kVA), can be calculated by the following formula:

$$S_{CONV} = \sqrt{3} \times I_{in} \times V_{in} / 1000$$

(I_{in} : Rated input current [A], V_{in} : Applicable power supply voltage [V])

Connection to Power Supply

The total impedance of the power supply and wiring for the rated current of the drive is %Z = 10% or more. Power voltage distortion may occur when the impedance of the power supply is too large. When wiring over long distances, be sure to take preventative measures such as using thick cables or series wiring to lower the impedance of wiring. Also, tie the cables for three phases together at the power supply side (do not isolate the cable for each phase). If not, increased cable inductance will increase the voltage of the main circuit power supply input terminal. Contact Yaskawa or a Yaskawa representative for details.

Grounding the Power Supply

Yaskawa recommends using a dedicated ground for the power supply, as the drive is designed to run with a 1:1 ratio relative to the power supply. Ground other devices as directed in the specifications for those devices. Take particular care when connecting sensitive electronic devices. Separate ground lines and install a noise filter to prevent problems from noise.

When Using a Generator as a Power Supply

Select the generator capacity approximately twice as large as the drive input power supply capacity. Set the deceleration time or load so that the regenerative power from the motor will be 10% or less of the generator capacity. For further information, contact Yaskawa or a Yaskawa representative.

When a Phase Advance Capacitor or Thyristor Controller is Provided for the Power Supply

Do not install a phase advancing capacitor to the drive.

For the phase advance capacitor that has already been installed on the same power supply system as the drive, switch to a phase-advanced capacitor with a series reactor to prevent oscillation with the drive.

Contact Yaskawa or a Yaskawa representative when a device generating voltage surge or voltage distortion such as DC motor drive thyristor controller or magnetic agitator is installed on the same power supply system.

Effects of Power Supply Distortion

Distortion of the power supply voltage increases the harmonics contents due to power supply harmonics entering the drive.

Starting Torque

The startup and acceleration characteristics of the motor are restricted to the drive overload current rating (120% 60 s).

The overload rating for the drive determines the starting and accelerating characteristics of the motor. Expect lower torque than when running from line power. To achieve a higher starting torque, use a larger drive or a drive and motor with larger capacity.

Emergency Stop

During a drive fault condition, the output shuts off but the motor does not stop immediately. A mechanical brake may be required when it is necessary to stop the motor faster than the ability of the Fast Stop function of the drive.

Repetitive Starting/Stopping

Laundry machines, punching presses, and other applications with frequent starts and stops often approach 150% of their rated output current values. Heat stress generated from repetitive high current will shorten the life span of the IGBTs. The expected life span of the IGBTs is about 8 million start and stop cycles with a 4 kHz carrier frequency (3 kHz carrier frequency for models 4□0477 to 4□0930) and a 150% peak current.

Run only one motor from each drive when using vector control. It is not possible to run more than one motor from one drive with vector control.

■ Carrier Frequency Derating

Reduce the rated output current of the drive when increasing the carrier frequency above the factory default setting.

■ Installation

Enclosure Panels

Keep the drive in a clean environment by installing the drive in an enclosure panel or selecting an installation area free of airborne dust, lint, and oil mist. Be sure to leave the required space between drives to provide for cooling, and take proper measures so the ambient temperature remains within allowable limits and keep flammable materials away from the drive. Yaskawa offers protective designs for drives that must be used in areas subjected to oil mist and excessive vibration. Contact Yaskawa or a Yaskawa representative for details.

Installation Direction

NOTICE: *Install the drive upright as specified in the manual. Refer to the Mechanical Installation section for more information on installation. Failure to comply may damage the drive due to improper cooling.*

■ Settings

Upper Limits

NOTICE: *The drive is capable of running the motor up to 400 Hz. Be sure to set the upper limit for the frequency of the drive to prevent the possible danger of accidentally operating equipment at higher than rated speed. The default setting for the maximum output frequency is 60 Hz.*

DC Injection Braking

NOTICE: *Excessive current during DC Injection Braking and excessive duration of DC Injection Braking can cause motor overheat.*

Acceleration/Deceleration Times

Acceleration and deceleration times are affected by the amount of torque generated by the motor, the load torque, and the moment of inertia. Set a longer accel/decel time when Stall Prevention is enabled. The accel/decel times are lengthened for as long as the Stall Prevention function is in operation. Install one of the available braking options or increase the capacity of the drive for faster acceleration and deceleration.

■ General Handling

Wiring Check

NOTICE: *Be sure to perform a final check of all sequence wiring and other connections before turning on the power and also check for short circuits on the control terminals, which may damage the drive.*

Selecting a Circuit Breaker or Circuit Interrupter

Yaskawa recommends installing a Ground Fault Circuit Interrupter (GFCI) to the power supply side. The GFCI should be designed for use with AC drives (e.g., Type B according to IEC/EN 60755).

Select a Molded Case Circuit Breaker (MCCB) or GFCI with a rated current 1.5 to 2 times higher than the drive rated current. [Refer to Installing a Molded Case Circuit Breaker \(MCCB\) or Ground Fault Circuit Interrupter \(GFCI\) on page 301](#) for more information.

Magnetic Contactor Installation

WARNING! *Fire Hazard. Shut off the drive with a magnetic contactor (MC) when a fault occurs in any external equipment such as braking resistors. Failure to comply may cause resistor overheating, fire, and injury to personnel.*

NOTICE: *To get the full performance life out of the capacitor for the control power supply and circuit relays, refrain from switching the drive power supply off and on more than once every 30 minutes. Frequent use can damage the drive. Use the drive to stop and start the motor.*

i.2 General Safety

Inspection and Maintenance

WARNING! Electrical Shock Hazard. Capacitors in the drive do not immediately discharge after shutting off the power. Wait for at least the amount of time specified on the drive before touching any components after shutting off the power. Failure to comply may cause injury to personnel from electrical shock.

WARNING! Electrical Shock Hazard. Take the precautions described below to prevent shock and injury:

- In applications where the machine can still rotate after the drive has fully stopped a load, install a switch to the drive output side to disconnect the motor and the drive.
- Do not allow an external force to rotate the motor beyond the maximum allowable speed or to rotate the motor when the drive has been shut off.
- Wait for at least the time specified on the warning label after opening the load switch on the output side before inspecting the drive or performing any maintenance.
- Do not open and close the load switch while the motor is running.
- If the motor is coasting, make sure the power to the drive is turned on and the drive output has completely stopped before closing the load switch.

WARNING! Burn Hazard. Because the heatsink can get very hot during operation, take proper precautions to prevent burns. When replacing the cooling fan, shut off the power and wait at least 15 minutes to be sure that the heatsink has cooled down. Failure to comply may cause burn injury to personnel.

Wiring

All wire ends should use ring terminals for UL/cUL compliance. Use only the tools recommended by the terminal manufacturer for crimping.

Transporting the Drive

NOTICE: Never steam clean the drive. During transport, keep the drive from coming into contact with salts, fluorine, bromine, phthalate ester, and other such harmful chemicals.

◆ Motor Application Precautions

■ Standard Induction Motors

Low-Speed Range

The cooling fan of a standard motor should sufficiently cool the motor at the rated speed. As the self-cooling capability of such a motor decreases with the speed, applying full torque at low speed will possibly damage the motor. Reduce the load torque as the motor slows to prevent motor damage from overheat. [Figure i.1](#) shows the allowable load characteristics for a Yaskawa standard motor. Use a motor designed specifically for operation with a drive when 100% continuous torque is needed at low speeds.

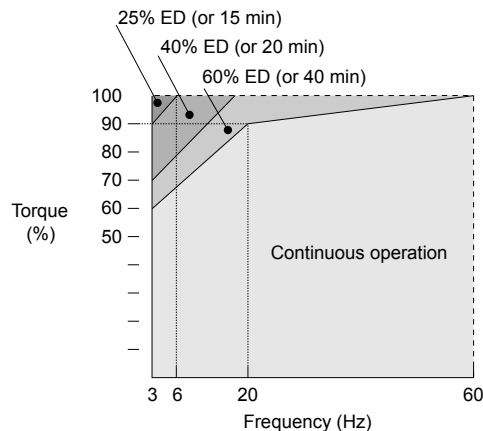

Figure i.1 Allowable Load Characteristics for a Yaskawa Motor

Insulation Tolerance

NOTICE: Consider motor voltage tolerance levels and motor insulation in applications with an input voltage of over 440 V or particularly long wiring distances.

High-Speed Operation

NOTICE: Problems may occur with the motor bearings and dynamic balance of the machine when operating a motor beyond its rated speed. Contact the motor or machine manufacturer.

Torque Characteristics

Torque characteristics differ compared to operating the motor directly from line power. The user should have a full understanding of the load torque characteristics for the application.

Vibration and Shock

The drive allows selection of high carrier PWM control.

- Take particular caution when adding a variable speed drive to an application running a motor from line power at a constant speed. If resonance occurs, install shock-absorbing rubber around the base of the motor and enable the Jump Frequency function to prevent continuous operation in the resonant frequency range.
- Mechanical resonance can occur with long motor shafts and in applications such as turbines, blowers, and fans with high inertia loads.

Audible Noise

The audible noise of the motor varies based on the carrier frequency setting. However, drive current derating may be required. When using a high carrier frequency, audible noise from the motor is comparable to the motor noise generated when running from line power.

Synchronous Motors

- Contact Yaskawa or a Yaskawa agent when planning to use a synchronous motor not endorsed by Yaskawa.
- Use a standard induction motor when running multiple synchronous motors simultaneously. A single drive does not have this capability.
- A synchronous motor may rotate slightly in the opposite direction of the Run command at start depending on parameter settings and rotor position.
- The amount of generated starting torque differs depending on the control mode and motor type. Set up the motor with the drive after verifying the starting torque, allowable load characteristics, impact load tolerance, and speed control range.
Contact Yaskawa or a Yaskawa agent when planning to use a motor that does not fall within these specifications:
- Contact Yaskawa or a Yaskawa agent for questions concerning applications with larger inertia.
- Use the Speed Search function to restart a coasting motor rotating over 200 Hz while in V/f Control.

Specialized Motors

Multi-Pole Motor

The rated current of a multi-pole motor differs from that of a standard motor, so be sure to check the maximum current when selecting a drive. Always stop the motor before switching between the number of motor poles. The motor will coast to stop if a regenerative overvoltage (ov) fault occurs or if overcurrent (oC) protection is triggered.

Submersible Motor

The rated current of a submersible motor is greater than that of a standard motor, so select the drive accordingly. Use a motor cable large enough to avoid decreasing the maximum torque level from voltage drop caused by a long motor cable.

Explosion-Proof Motor

The motor and the drive must be tested together to be certified as explosion-proof. The drive is not designed for explosion-proof areas.

When attaching an encoder to an explosion-proof motor, make sure the encoder is also explosion-proof. Use an insulating signal converter to connect the encoder signal lines to the speed feedback option card.

Geared Motor

Make sure that the gear and the lubricant are rated for the desired speed range to avoid gear damage when operating at low speeds or very high speeds. Consult with the manufacturer for applications that require operation outside the rated speed range of the motor or gear box.

Single-Phase Motor

Variable speed drives are not designed to operate with single phase motors. Using capacitors to start the motor causes a high-frequency current to flow to the capacitors and can damage the capacitors. A split-phase start or a repulsion start can burn out the starter coils because the internal centrifugal switch is not activated. The drive is for use with three-phase motors only.

Motor with Brake

Take caution when using the drive to operate a motor with a built-in holding brake. If the brake is connected to the output side of the drive, it may not release at start due to low voltage levels, so be sure to install a separate power supply for the motor brake. Note that motors with built-in brakes tend to generate a fair amount of noise when running at low speeds.

Notes on Power Transmission Machinery

Installing an AC drive in machinery that was previously connected directly to the power supply will allow the machine to operate at variable speeds. Continuous operation outside of the rated speeds can wear out lubrication material in gear boxes and other power transmission parts. Make sure that lubrication is sufficient within the entire speed range to avoid machine damage. Note that operation above the rated speed can increase the noise generated by the machine.

◆ Drive Label Warning Example

Always heed the warning information listed in *Figure i.2*.

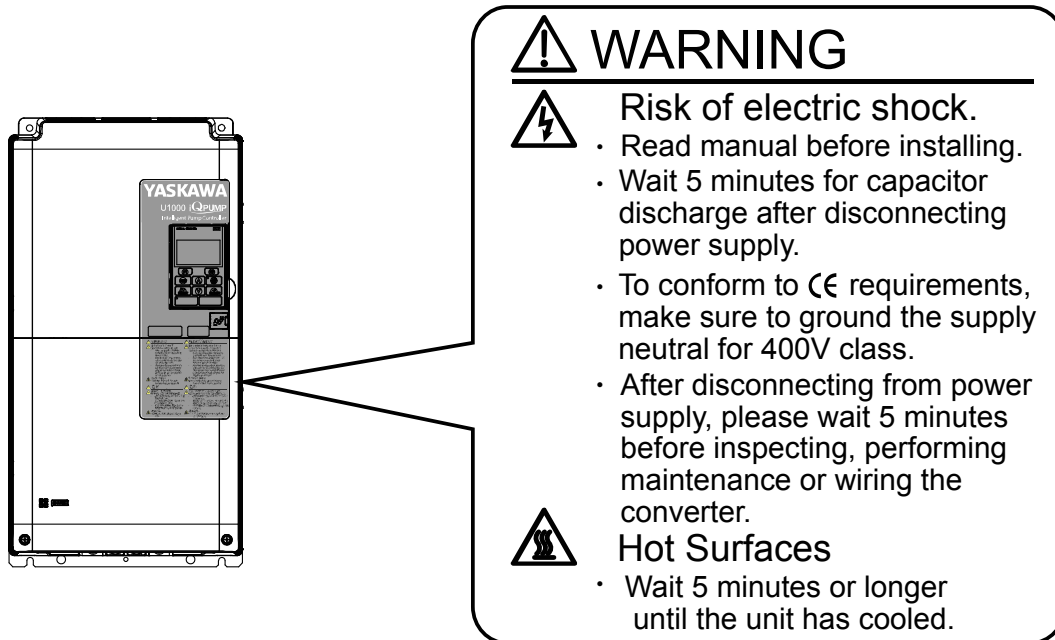

Figure i.2 Warning Information Example and Position

◆ Warranty Information

■ Restrictions

The drive is not designed or manufactured for use in devices or systems that may directly affect or threaten human lives or health.

Customers who intend to use the product described in this manual for devices or systems relating to transportation, health care, space aviation, atomic power, electric power, or in underwater applications must first contact Yaskawa or a Yaskawa representative.

WARNING! Injury to Personnel. *This product has been manufactured under strict quality-control guidelines. However, if this product is to be installed in any location where failure of this product could involve or result in a life-and-death situation or loss of human life or in a facility where failure may cause a serious accident or physical injury, safety devices must be installed to minimize the likelihood of any accident.*

Receiving

This chapter explains how to inspect the drive upon receipt, and gives an overview of the different enclosure types and components.

1.1	SECTION SAFETY.....	22
1.2	GENERAL DESCRIPTION.....	23
1.3	MODEL NUMBER AND NAMEPLATE CHECK.....	25
1.4	DRIVE MODELS AND ENCLOSURES.....	30
1.5	COMPONENT NAMES.....	32

1.1 Section Safety

CAUTION

Do not carry the drive by the front cover or the terminal cover.

Failure to comply may cause the main body of the drive to fall, resulting in minor or moderate injury.

NOTICE

Observe proper electrostatic discharge procedures (ESD) when handling the drive and circuit boards.

Failure to comply may result in ESD damage to the drive circuitry.

A motor connected to a the drive may operate at a higher temperature than a utility-fed motor and the operating speed range may reduce motor cooling capacity.

Ensure that the motor is suitable for drive duty and/or the motor service factor is adequate to accommodate the additional heating with the intended operating conditions.

1.2 General Description

◆ U1000 iQpump Model Selection

Refer to [Table 1.1](#) for drive selection.

Note: The models and capacities in shown here are based on standard settings and operation conditions. Higher carrier frequencies and higher ambient temperatures require derating.

Table 1.1 U1000 iQpump Models

Three-Phase 200 V Class		Three-Phase 400 V Class	
Drive Model	Rated Output Current (A)	Drive Model	Rated Output Current (A)
2□0028	28	4□0011	11
2□0042	42	4□0014	14
2□0054	54	4□0021	21
2□0068	68	4□0027	27
2□0081	81	4□0034	34
2□0104	104	4□0040	40
2□0130	130	4□0052	52
2□0154	154	4□0065	65
2□0192	192	4□0077	77
2□0248	248	4□0096	96
–	–	4□0124	124
–	–	4□0156	156
–	–	4□0180	180
–	–	4□0216	216
–	–	4□0240	240
–	–	4□0302	302
–	–	4□0361	361
–	–	4□0414	414
–	–	4□0477	477
–	–	4□0590	590
–	–	4□0720	720
–	–	4□0930	930

◆ Control Mode Selection

[Table 1.2](#) gives an overview of the U1000 iQpump control modes and their various features.

Table 1.2 Control Modes and Features

Motor Type		Induction Motors		Comments
Control Mode		V/f	OLV	–
Parameter Setting		A1-02 = 0	A1-02 = 2	Default Setting is V/f control (A1-02 = 0)
Basic Description		V/f control	Open Loop Vector control	–
Type of Applications	Motor Type	IM	IM	–
	Multi Motor	YES	–	–
	Motor data unknown	YES	–	–
	High Speed Accuracy	–	YES	–
	High Speed Response	–	YES	–
Torque Limit Operation		–	YES	–

1.2 General Description

Motor Type		Induction Motors		Comments
Control Mode		V/f	OLV	–
Control Characteristics	Speed Control Range	1:40	1:200	May fluctuate with characteristics and motor temperature.
	Speed Accuracy	±2 to 3%	±0.2%	Speed deviation rate between speed reference value and motor speed (100% = rated speed, motor temperature 25 °C ±10 °C) when operating at normal status and when load is stable.
	Speed Response	3 Hz (approximately)	10 Hz	Maximum frequency of a speed reference signal that the drive can follow may fluctuate with characteristics and motor temperature.
	Starting Torque	150% at 3 Hz	200% at 0.3 Hz	Starting torque may fluctuate with characteristics and motor temperature. Performance may differ by capacity.
Application-Specific	Auto-Tuning	• Stationary Auto-Tuning for Line-to-Line Resistance	• Stationary Auto-Tuning 2 • Stationary Auto-Tuning 3 • Rotational Auto-Tuning	Automatically adjusts parameter settings that concern electrical characteristics of the motor
		• Rotational Auto-Tuning for V/f Control		
	Torque Limit	–	YES	Sets the maximum torque for the motor to protect the load and connected machinery.
	Speed Search	YES	YES	Bi-directional speed detection of a coasting motor to restart it without stopping.
	Energy-Saving Control	YES	YES	Saves energy by always operating the motor at its maximum efficiency.
	Overexcitation Deceleration	YES	YES	Provides fast deceleration without using a braking resistor.
	Commercial Power Switching Selection	YES	–	When the output frequency matches the power supply frequency (60 Hz), the PWM switching operation stops and switches to operation with a direct commercial power supply connection.

1.3 Model Number and Nameplate Check

Please perform the following tasks after receiving the drive:

- Inspect the drive for damage.
If the drive appears damaged upon receipt, contact the shipper immediately.
- Verify receipt of the correct model by checking the information on the nameplate.
- If you have received the wrong model or the drive does not function properly, contact Yaskawa or a Yaskawa representative.

◆ Nameplate

■ Drive Models 2□0028 to 2□0248 and 4□0011 to 4□0590

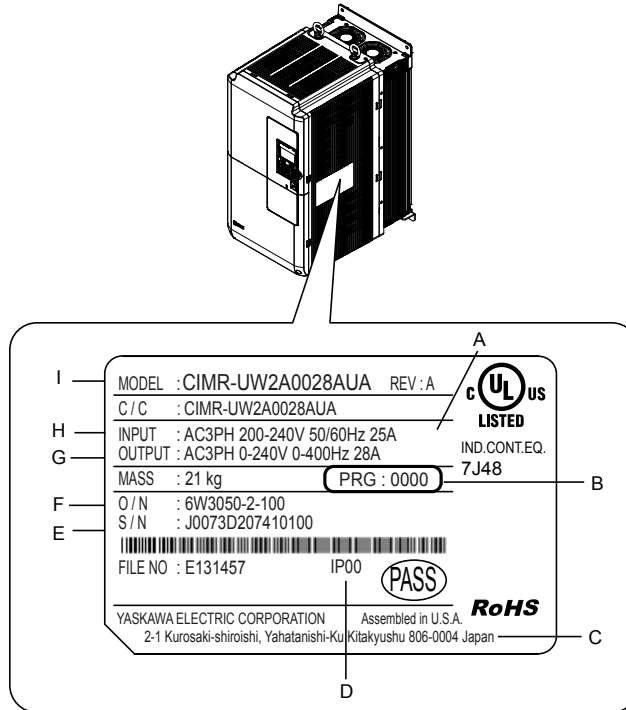

- | | |
|-----------------------------|--|
| A – Duty amps | F – Lot number |
| B – Software version | G – Output specifications |
| C – Address <1> | H – Input specifications |
| D – Enclosure type | I – AC drive model |
| E – Serial number | Refer to Figure 1.4 for details. |

Figure 1.1 Drive Nameplate Information Example

<1> The address of the head office of Yaskawa Electric Corporation (responsible for product liability) is shown on the nameplate.

1.3 Model Number and Nameplate Check

■ Drive Models 4□0720 to 4□0930

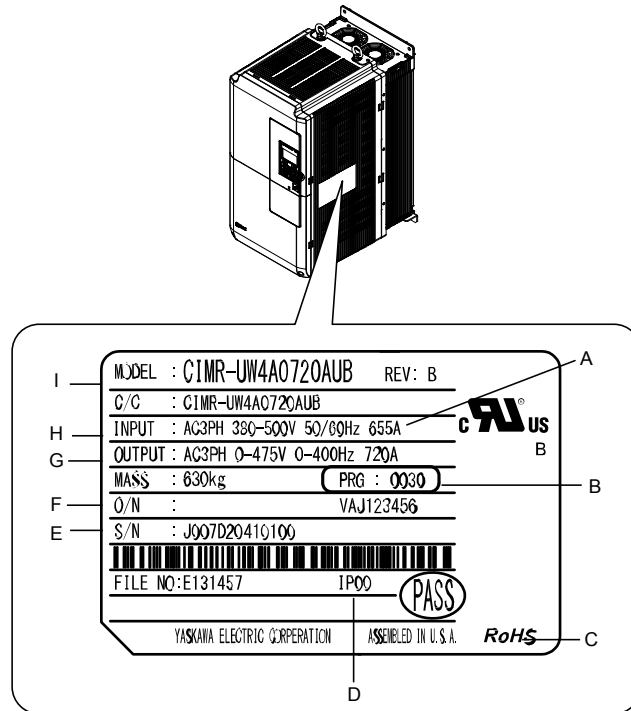

A – Duty amps
B – Software version
C – Address <1>
D – Enclosure type
E – Serial number

F – Lot number
G – Output specifications
H – Input specifications
I – AC drive model
Refer to [Figure 1.4](#) for details.

Figure 1.2 Drive Nameplate Information Example

<1> The address of the head office of Yaskawa Electric Corporation (responsible for product liability) is shown on the nameplate.

■ Harmonic Filter Module

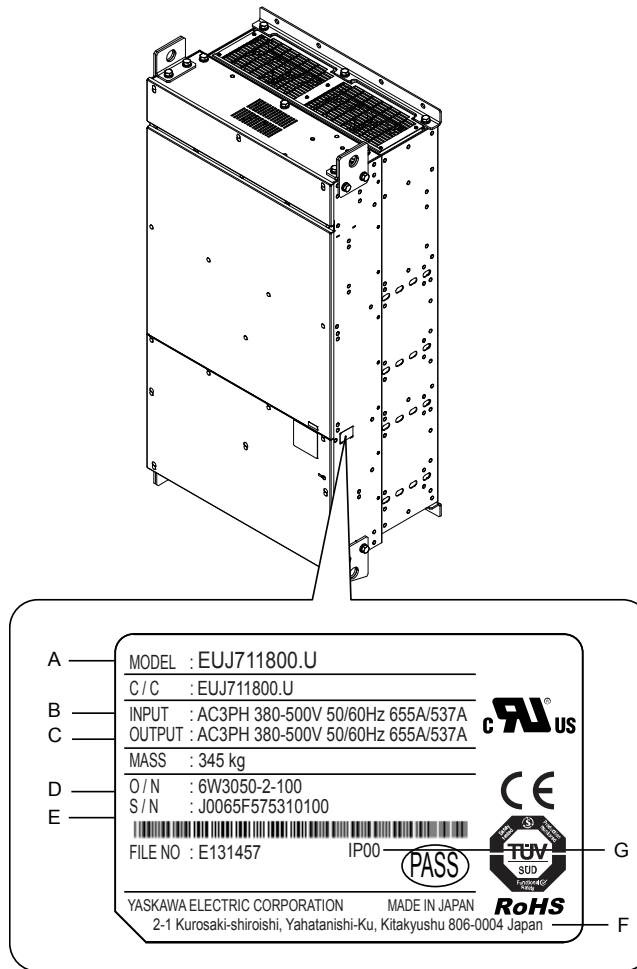

- A – Model number**
- B – Input specifications**
- C – Output specifications**
- D – Lot number**

- E – Serial number**
- F – Address <1>**
- G – Enclosure type**

Figure 1.3 Harmonic Filter Module Nameplate Information Example

<1> The address of the head office of Yaskawa Electric Corporation (responsible for product liability) is shown on the nameplate.

◆ Model Number

■ Drive Models 2□0028 to 2□0248 and 4□0011 to 4□0930

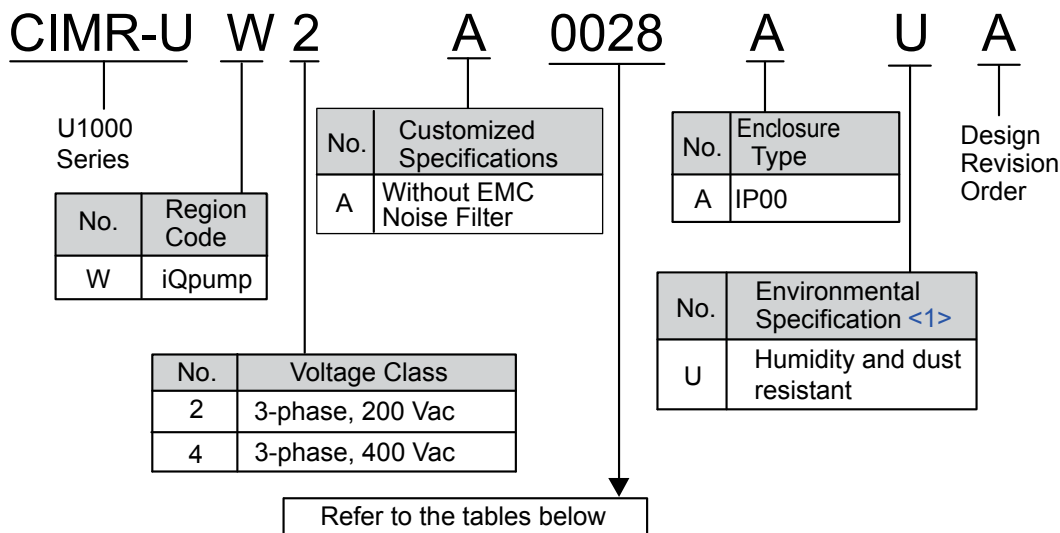

Figure 1.4 Drive Model Number Definition

<1> Drives with these specifications do not guarantee complete protection for the environmental conditions indicated.

■ Three-Phase 200 V Class

Table 1.3 Model Number and Specifications (200 V Class)

Drive Model	Reference Motor Capacity kW (HP)	Rated Output Current A
2□0028	7.5 (10)	28
2□0042	11 (15)	42
2□0054	15 (20)	54
2□0068	18.5 (25)	68
2□0081	22 (30)	81
2□0104	30 (40)	104
2□0130	37 (50)	130
2□0154	45 (60)	154
2□0192	55 (75)	192
2□0248	75 (100)	248

■ Three-Phase 400 V Class

Table 1.4 Model Number and Specifications (400 V Class)

Drive Model	Reference Motor Capacity kW (HP)	Rated Output Current A
4□0011	5.5 (7.5)	11
4□0014	7.5 (10)	14
4□0021	11 (15)	21
4□0027	15 (20)	27
4□0034	18.5 (25)	34
4□0040	22 (30)	40
4□0052	30 (40)	52
4□0065	37 (50)	65
4□0077	45 (60)	77
4□0096	55 (75)	96
4□0124	75 (100)	124
4□0156	90 (125)	156

1.3 Model Number and Nameplate Check

Drive Model	Reference Motor Capacity kW (HP)	Rated Output Current A
4□0180	110 (150)	180
4□0216	132 (175)	216
4□0240	150 (200)	240
4□0302	185 (250)	302
4□0361	220 (300)	361
4□0414	260 (350)	414
4□0477	300 (400)	477
4□0590	375 (500)	590
4□0720	450 (600)	720
4□0930	580 (800)	930

1.4 Drive Models and Enclosures

Yaskawa offers IP00/Open Type enclosures for the U1000 iQpump. IP00/Open Type models are designed for installation in an enclosure panel that serves to protect personnel from injury caused by accidentally touching live parts.

Customers who want IP20/NEMA 1, UL Type 1 enclosure models that mount to an indoor wall or in an enclosure panel must purchase the optional NEMA 1 End Cap Kit. [Refer to IP20/NEMA 1, UL Type 1 Kit Selection on page 57.](#)

[Table 1.5](#) describes drive models and enclosures.

◆ Drive Models 2□0028 to 2□0248 and 4□0011 to 4□0930

[Table 1.5](#) describes drive enclosures and models.

Table 1.5 Drive Models and Enclosure Types

Voltage Class	Enclosure Type	
	IP00/Open Type Enclosure Drive Models	IP20/NEMA 1, UL Type 1 Enclosure ^{<1>} Drive Models
Three-Phase 200 V Class	2□0028A	—
	2□0042A	—
	2□0054A	—
	2□0068A	—
	2□0081A	—
	2□0104A	—
	2□0130A	—
	2□0154A	—
	2□0192A	—
	2□0248A	—
Three-Phase 400 V Class	4□0011A	—
	4□0014A	—
	4□0021A	—
	4□0027A	—
	4□0034A	—
	4□0040A	—
	4□0052A	—
	4□0065A	—
	4□0077A	—
	4□0096A	—
	4□0124A	—
	4□0156A	—
	4□0180A	—
	4□0216A	—
	4□0240A	—
	4□0302A	—
	4□0361A	—
	4□0414A	—
	4□0477A	—
	4□0590A	—
4□0720A	—	
4□0930A	—	

<1> Attach a top protective cover and bottom cover from the optional End Cap Kit to an IP00/Open Type enclosure drive to convert the drive to an IP20/NEMA 1, UL Type 1 enclosure drive.

◆ Harmonic Filter Modules

Install a Three-Phase Harmonics Filter Module on the input side of drive models 4□0720 and 4□0930. Install the drive and peripherals in a suitable enclosure for end use. Refer to [Table 1.5](#) for details.

Table 1.6 Correspondence of Harmonic Filter Module Models and Enclosure Types for Drive Models 4□0720 and 4□0930

Voltage Class	Enclosure Type	
	IP00/Open Type Enclosure Drive Model	IP00/Open Type Enclosure Harmonic Filter Model
Three-Phase 400 V Class	4□0720	EUJ71180□.□
	4□0930	EUJ71182□.□

1.5 Component Names

This section gives an overview of the drive components and filter module components described in this manual.

- Note:**
1. Refer to *Using the HOA Keypad on page 118* for a description of the operator keypad.
 2. The drive may have no cooling fans or up to two cooling fans depending on the model.

◆ IP00/Open Type Enclosure

- Three-Phase AC 200 V Class Models 2□0028A to 2□0081A
- Three-Phase AC 400 V Class Models 4□0011A to 4□0077A

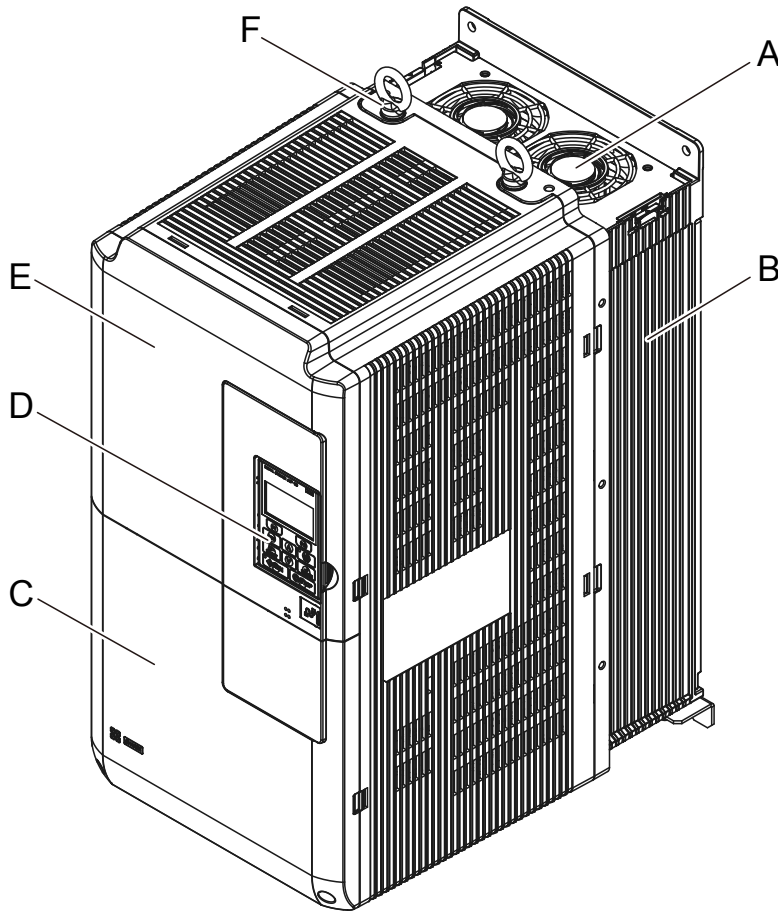

A – Cooling fan
B – Heatsink
C – Terminal cover

D – Digital operator
E – Front cover
F – Eye bolt

Figure 1.5 IP00/Open Type Components (Drive Model 2□0028A)

- Three-Phase AC 200 V Class Models 2□0104A to 2□0130A
- Three-Phase AC 400 V Class Models 4□0096A to 4□0124A

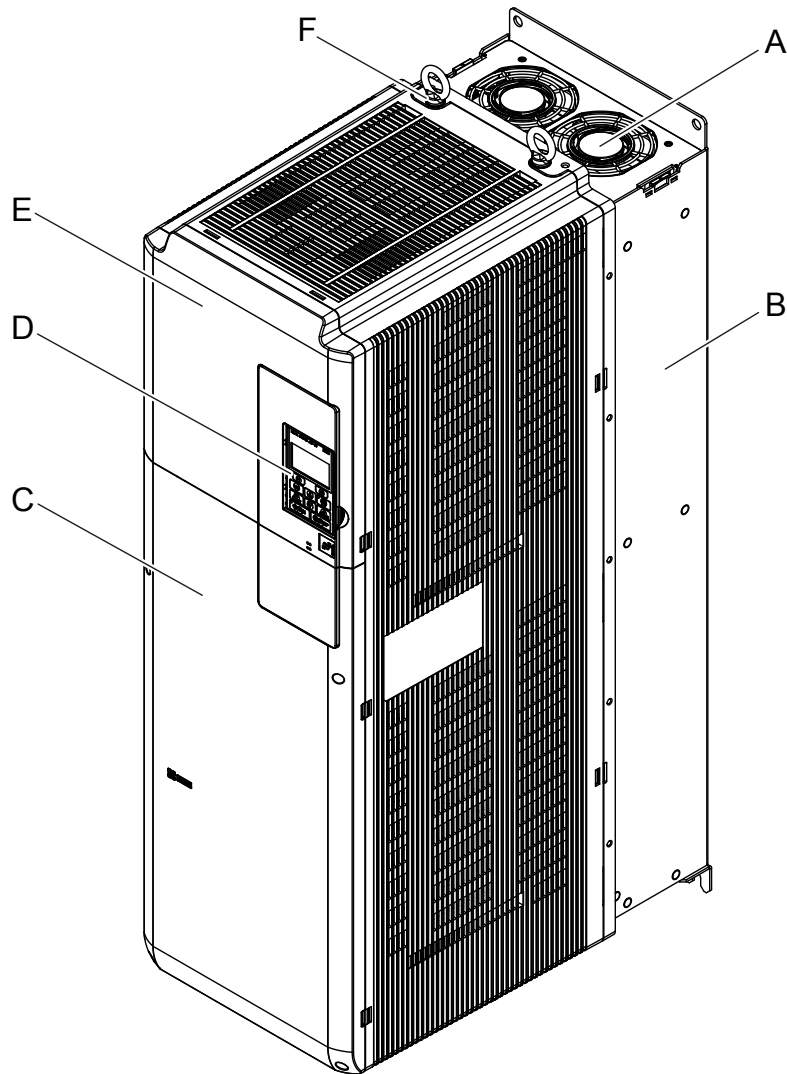

A – Cooling fan
 B – Heatsink
 C – Terminal cover

D – Digital operator
 E – Front cover
 F – Eye bolt

Figure 1.6 IP00/Open Type Components (Drive Model 2□0104A)

1.5 Component Names

- Three-Phase AC 200 V Class Models 2□0154A and 2□0192A
- Three-Phase AC 400 V Class Models 4□0156A and 4□0180A

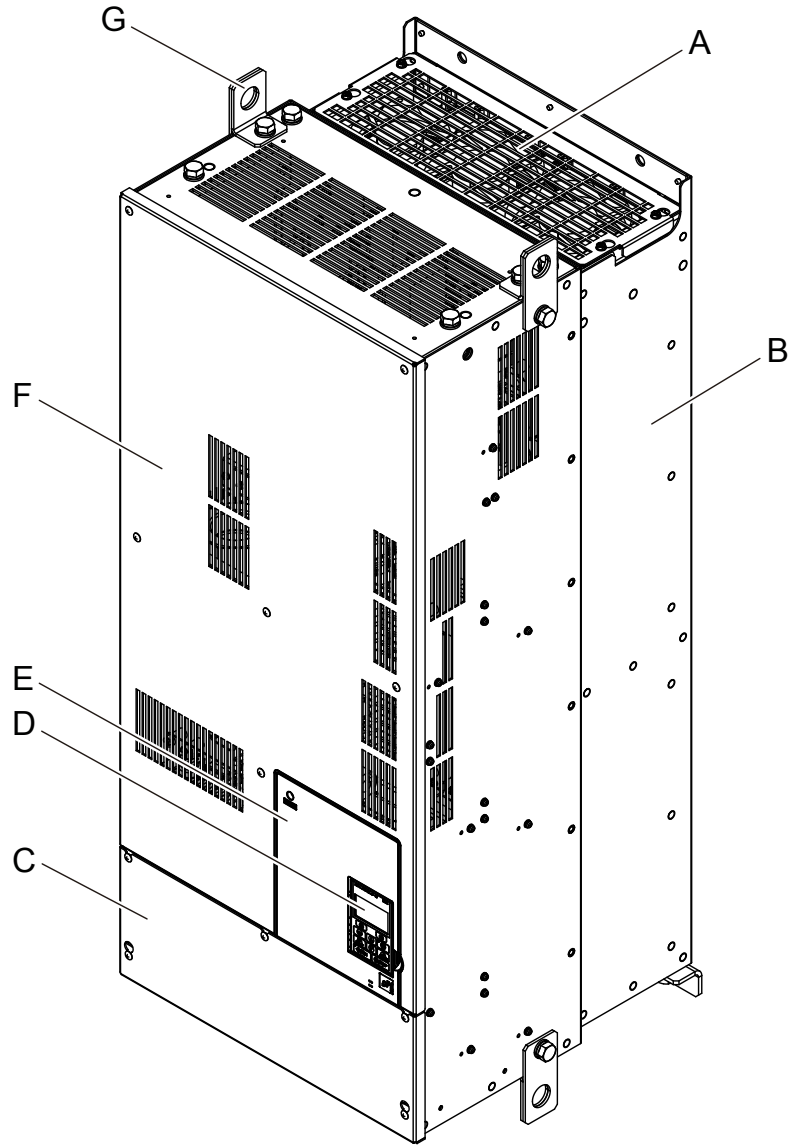

- | | |
|----------------------|---------------------|
| A – Cooling fan | E – Front cover |
| B – Heatsink | F – Drive cover |
| C – Terminal cover | G – Hanging bracket |
| D – Digital operator | |

Figure 1.7 IP00/Open Type Components (Drive Model 2□0154A)

■ Three-Phase AC 200 V Class Model 2□0248A
 Three-Phase AC 400 V Class Models 4□0216A to 4□0414A

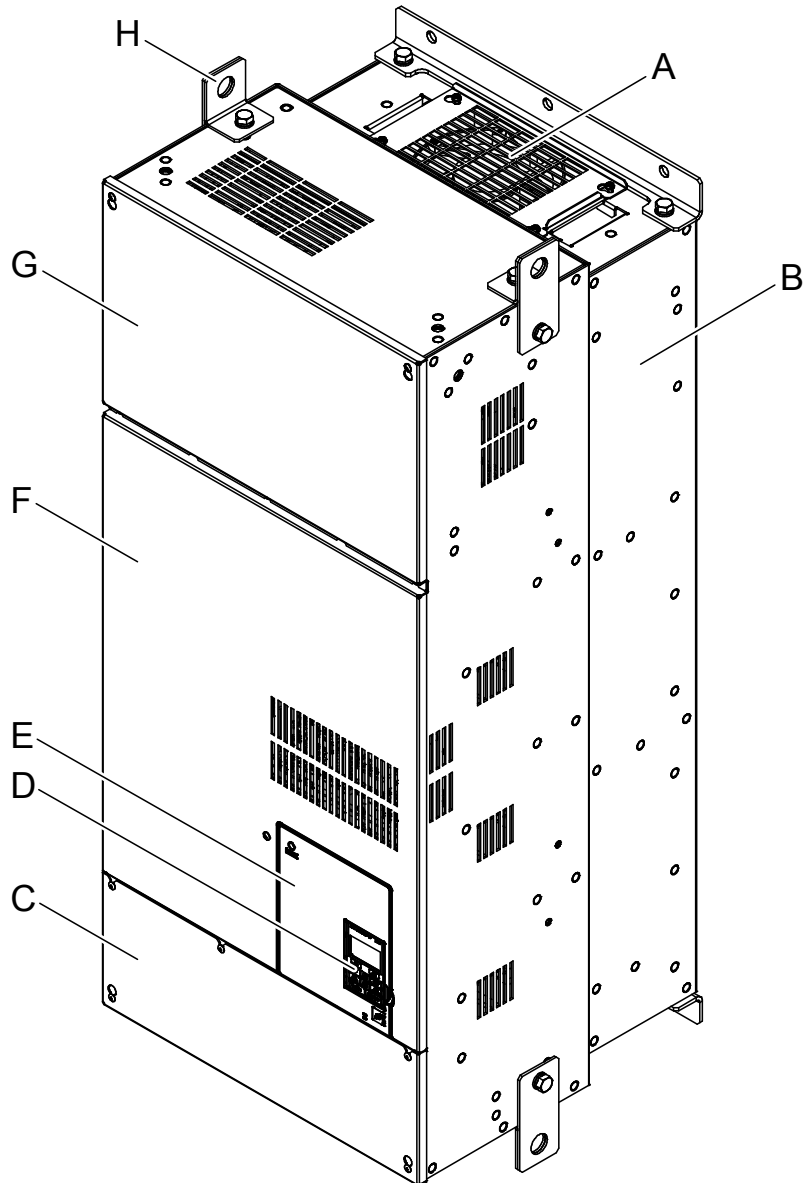

A – Cooling fan
 B – Heatsink
 C – Terminal cover
 D – Digital operator

E – Front cover
 F – Drive cover 2
 G – Drive cover 1
 H – Hanging bracket

Figure 1.8 IP00/Open Type Components (Drive Model 2□0248A)

■ Three-Phase AC 400 V Class Models 4□0477A and 4□0590A

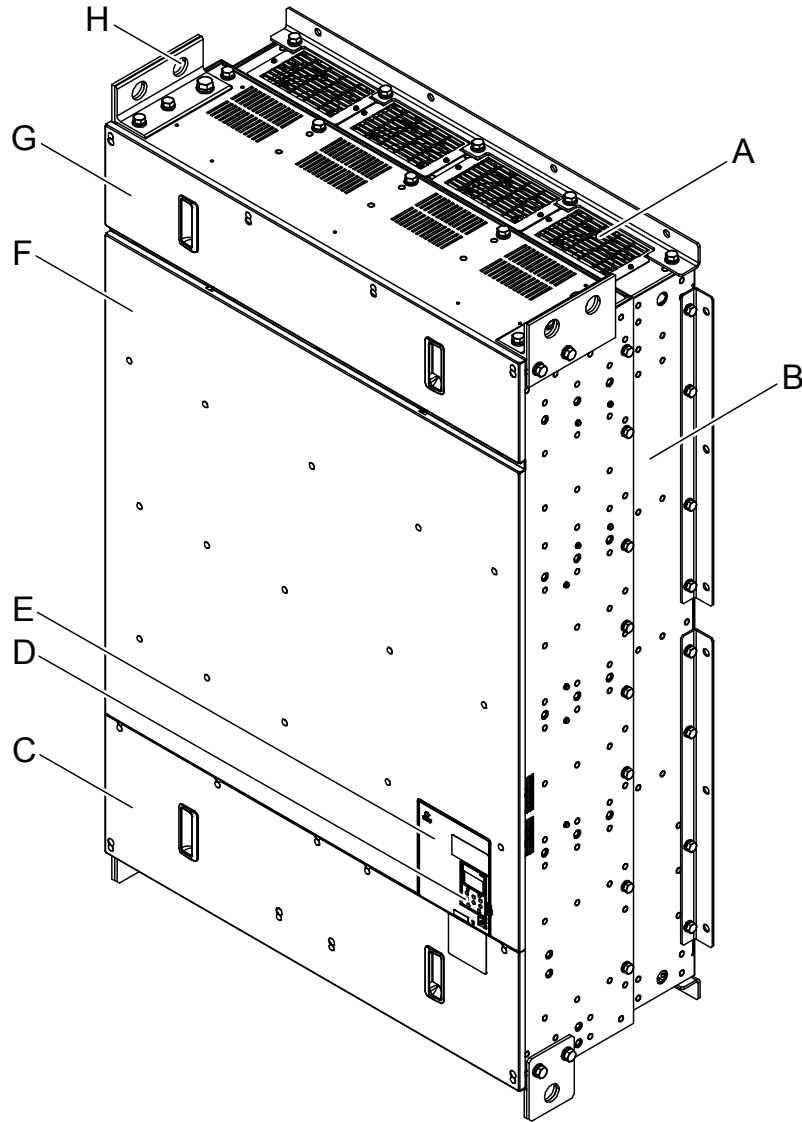

A – Cooling fan
B – Heatsink
C – Terminal cover
D – Digital operator

E – Front cover
F – Drive cover 2
G – Drive cover 1
H – Hanging bracket

Figure 1.9 IP00/Open Type Components (Drive Model 4□0477A)

■ Three-Phase AC 400 V Class Models 4□0720A to 4□0930A

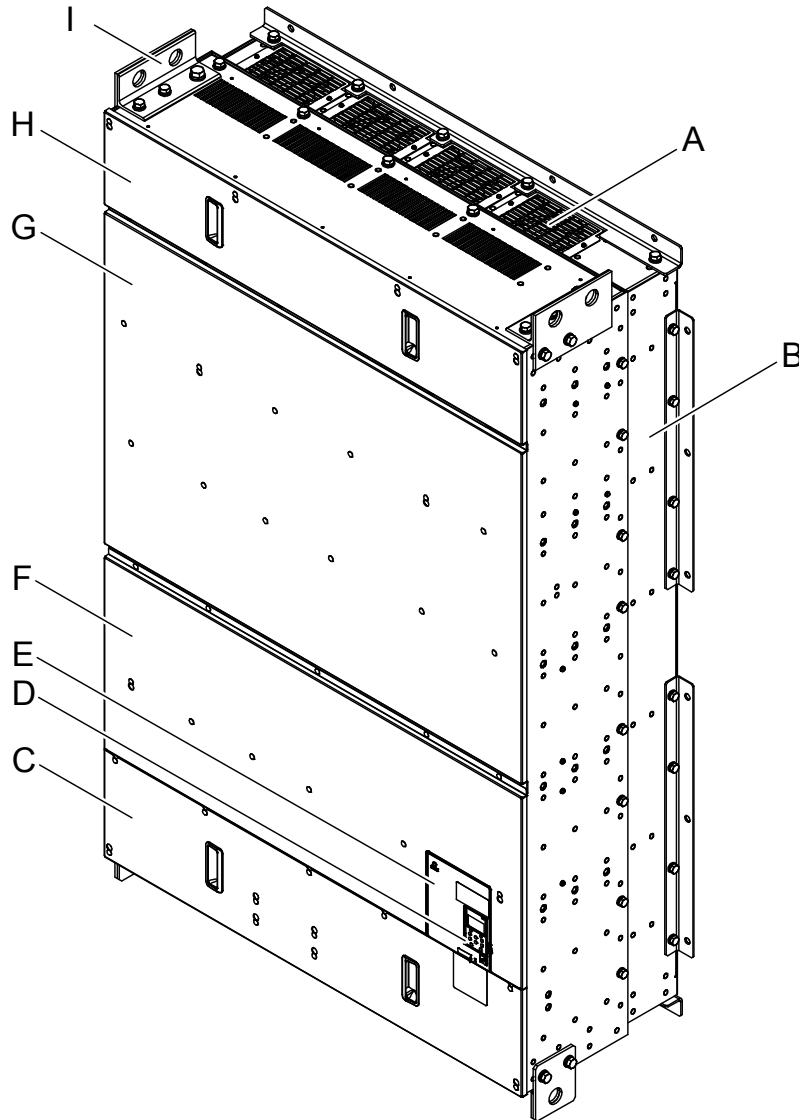

A – Cooling fan
 B – Heatsink
 C – Terminal cover
 D – Digital operator
 E – Front cover

F – Drive cover 2
 G – Drive cover 3
 H – Drive cover 1
 I – Hanging bracket

Figure 1.10 IP00/Open Type Components (Drive Model 4□0720A)

◆ Harmonic Filter Modules

Drive models 4□0720 to 4□0930 require stand-alone installation of input fuses, damping resistors, and AC reactors. These components are stored in a unit called the harmonic filter module.

■ Three-Phase AC 400 V Class Models

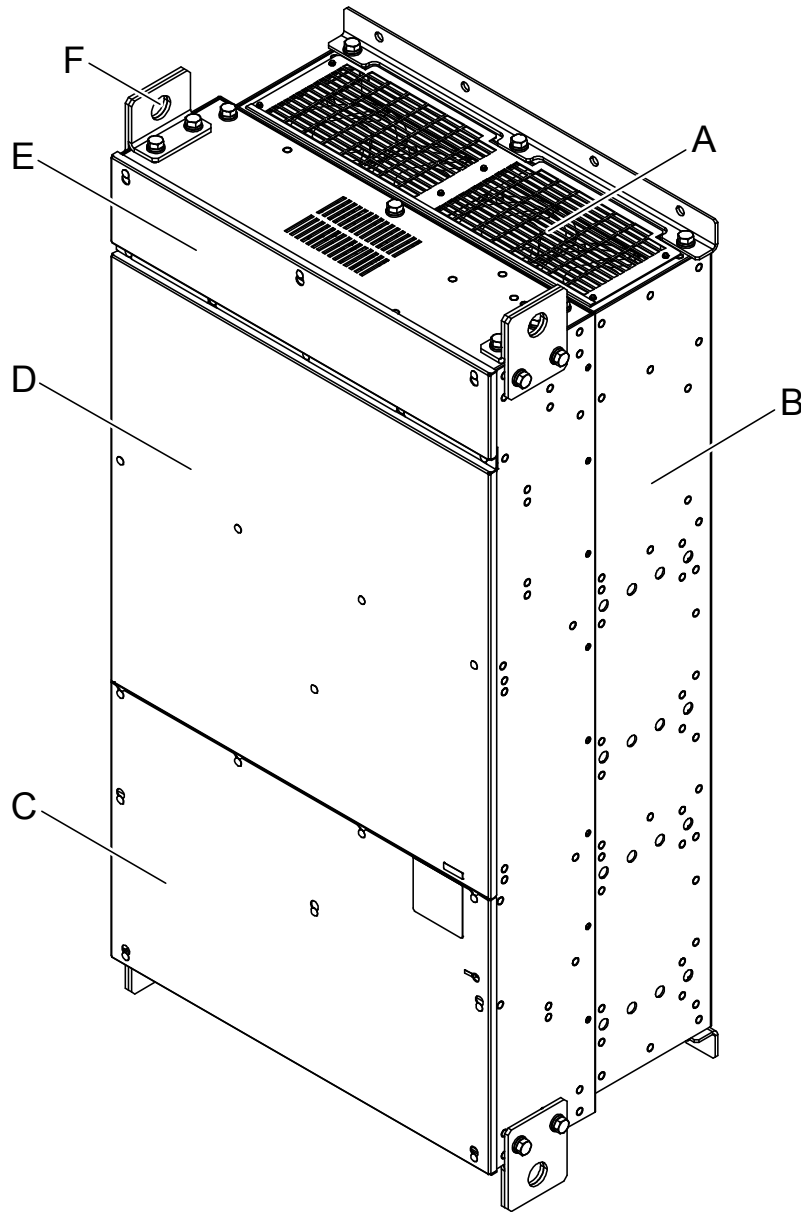

A – Cooling fan
B – Heatsink
C – Terminal cover

D – Harmonic filter module cover 2
E – Harmonic filter module cover 1
F – Hanging bracket

Figure 1.11 Harmonic Filter Module Components (Model EUJ7118□□□)

◆ Front Views

■ Drive Models 2□0028 to 2□0248 and 4□0011 to 4□0930

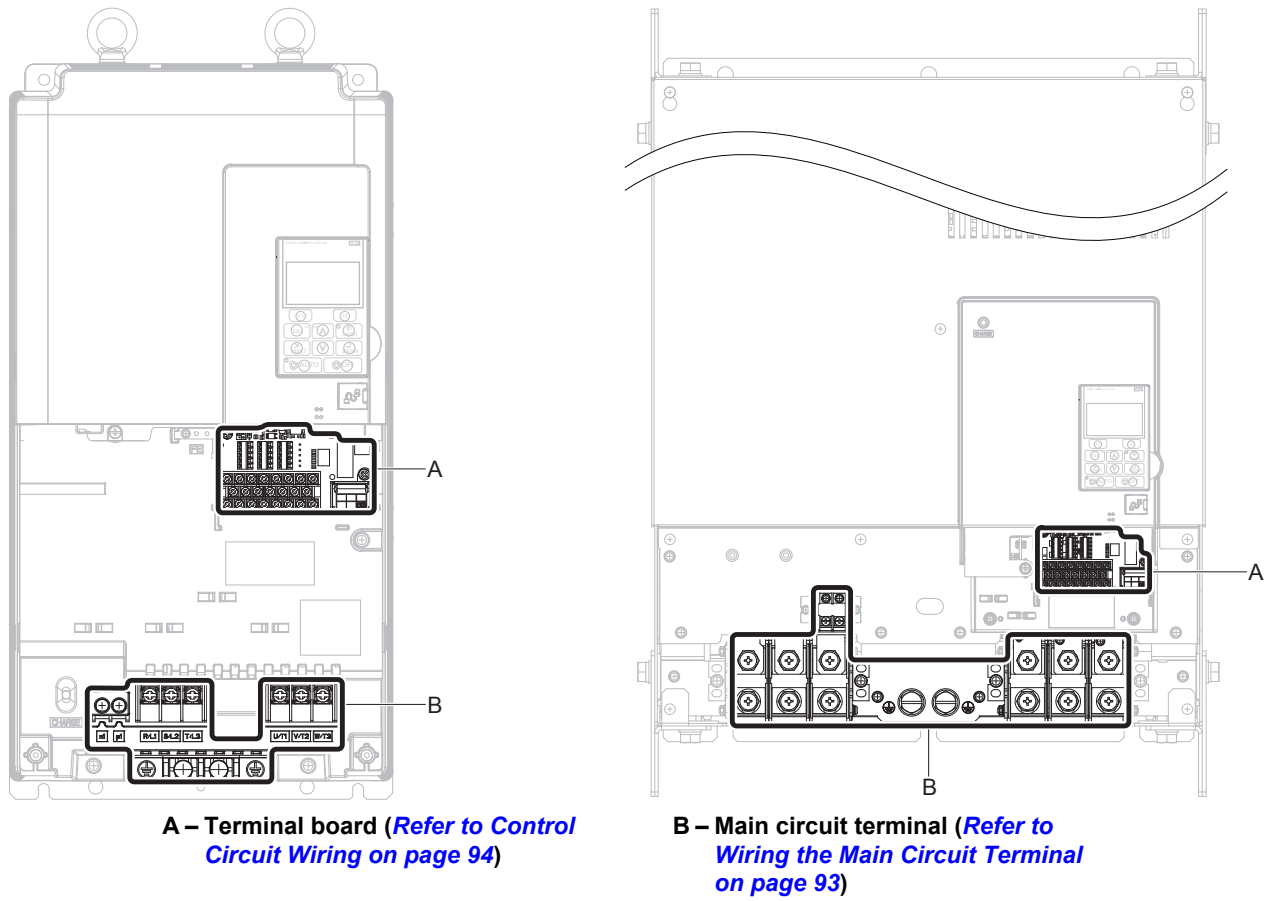
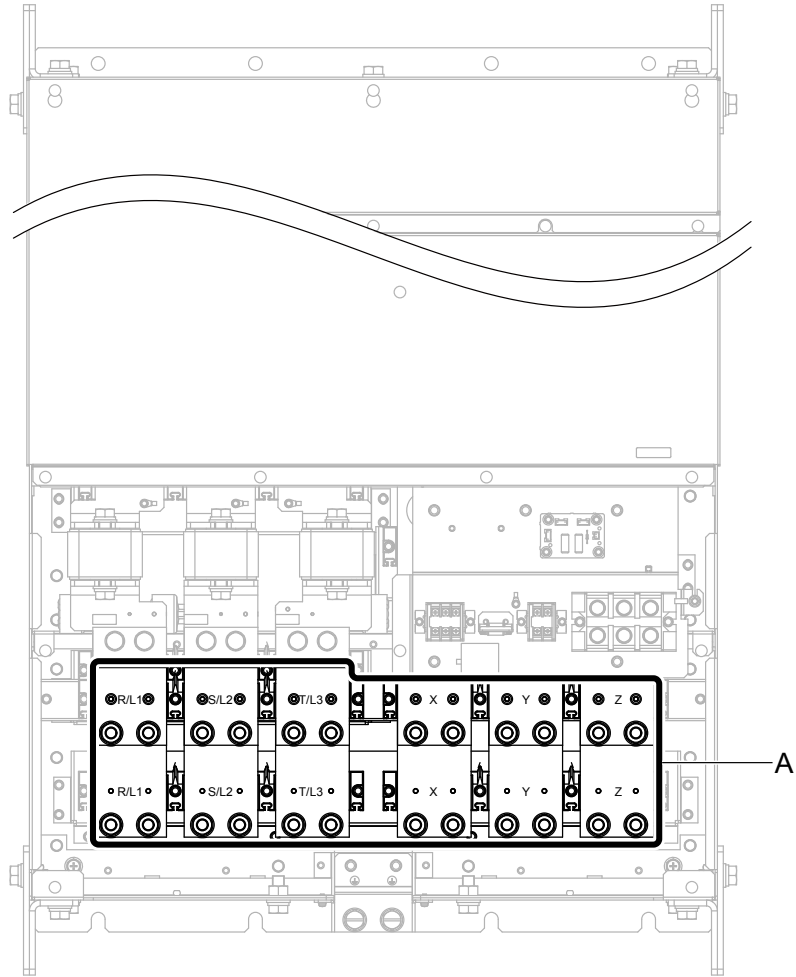

Figure 1.12 Front Views of Drives

■ Harmonic Filter Module



A –Main circuit terminal (*Refer to Harmonic Filter Module on page 84*)

Figure 1.13 Front View of Harmonic Filter Module (Model EUJ7118□□.□)

Mechanical Installation

This chapter explains how to properly mount and install the drive.

2.1	SECTION SAFETY.....	42
2.2	MECHANICAL INSTALLATION.....	44

2.1 Section Safety

WARNING

Fire Hazard

Provide sufficient cooling when installing the drive inside an enclosed panel or cabinet.

Failure to comply could result in overheating and fire.

When multiple drives are placed inside the same enclosure panel, install proper cooling to ensure air entering the enclosure does not exceed 40 °C.

Crush Hazard

Use a dedicated lifter when transporting the drive by a lifter.

Failure to comply may result in serious injury or death from falling equipment.

Only use vertical suspension to temporarily lift the drive during installation to an enclosure panel. Do not use vertical suspension to transport the drive.

Failure to comply may result in serious injury or death from falling equipment.

Use screws to securely affix the drive front cover, terminal blocks, and other drive components prior to vertical suspension.

Failure to comply may result in serious injury or death from falling equipment.

Do not subject the drive to vibration or impact greater than 1.96 m/s² (0.2 G) while it is suspended by the cables.

Failure to comply may result in serious injury or death from falling equipment.

Do not attempt to flip the drive over or leave the drive unattended while it is suspended by the wires.

Failure to comply may result in serious injury or death from falling equipment.

CAUTION

Crush Hazard

Do not carry the drive by the front cover or the terminal cover.

Failure to comply may result in minor or moderate injury from the main body of the drive falling.

NOTICE

Equipment Hazard

Prevent foreign matter such as metal shavings or wire clippings from falling into the drive during drive installation and project construction.

Failure to comply could result in damage to the drive. Place a temporary cover over the top during installation. Be sure to remove the temporary cover before start-up, as the cover will reduce ventilation and cause the unit to overheat.

Observe proper electrostatic discharge (ESD) procedures when handling the drive.

Failure to comply could result in ESD damage to the drive circuitry.

Operating the motor in the low-speed range diminishes the cooling effects, increases motor temperature, and may lead to motor damage by overheating.

Reduce the motor torque in the low-speed range whenever using a standard blower cooled motor. If 100% torque is required continuously at low speed, consider using a special drive or vector-control motor. Select a motor that is compatible with the required load torque and operating speed range.

The speed range for continuous operation differs according to the lubrication method and motor manufacturer.

If the motor is to be operated at a speed higher than the rated speed, consult with the manufacturer.

Continuously operating an oil-lubricated motor in the low-speed range may result in burning.

NOTICE

When the input voltage is 440 V or higher or the wiring distance is greater than 100 meters, pay special attention to the motor insulation voltage or use a drive-rated motor with reinforced insulation.

Failure to comply could lead to motor winding failure.

Motor vibration may increase when operating a machine in variable-speed mode, if that machine previously operated at a constant speed.

Install vibration-proof rubber on the motor base or use the frequency jump function to skip a frequency resonating the machine.

The motor may require more acceleration torque with drive operation than with a commercial power supply.

Set a proper V/f pattern by checking the load torque characteristics of the machine to be used with the motor.

The rated input current of submersible motors is higher than the rated input current of standard motors.

Select an appropriate drive according to its rated output current. When the distance between the motor and drive is long, use a cable thick enough to connect the motor to the drive to prevent motor torque reduction.

The current rating differs for a motor with variable pole pitches differs from a standard motor.

Check the maximum current of the motor before selecting the drive capacity. Only switch motor poles when the motor is stopped. Switching between motor during run will trigger overcurrent protection circuitry or result in overvoltage from regeneration, and the motor will simply coast to stop.

When using an explosion-proof motor, it must be subject to an explosion-proof test in conjunction with the drive.

This is also applicable when an existing explosion-proof motor is to be operated with the drive. Since the drive itself is not explosion-proof, always install it in a safe place.

Never lift the drive up while the cover is removed.

This can damage the terminal board and other components.

2.2 Mechanical Installation

This section outlines specifications, procedures, and the environment for proper mechanical installation of the drive and harmonic filter module.

◆ Installation Environment

Install the drive and harmonic filter module in an environment matching the specifications in [Table 2.1](#) and [Table 2.2](#) to help prolong optimum performance life.

■ Drive Models 2□0028 to 2□0248 and 4□0011 to 4□0930

Table 2.1 Drive Installation Environment

Environment	Conditions
Installation Area	Indoors
Ambient Temperature	IP00/Open Type enclosure: -10 °C to +50 °C (14 °F to 122 °F) IP20/NEMA 1, UL Type 1 enclosure: -10 °C to +40 °C (14 °F to 104 °F) <1> Drive reliability improves in environments without wide temperature fluctuations. When using the drive in an enclosure panel, install a cooling fan or air conditioner in the area to ensure that the air temperature inside the enclosure does not exceed the specified levels. Do not allow ice to develop on the drive.
Humidity	95% RH or less and free of condensation
Storage Temperature	-20 °C to +60 °C (-4 °F to +104 °F)
Surrounding Area	Install the drive in an area free from: <ul style="list-style-type: none"> • oil mist and dust • metal shavings, oil, water, or other foreign materials • radioactive materials • combustible materials (e.g., wood) • harmful gases and liquids • excessive vibration • chlorides • direct sunlight.
Altitude	1000 m (3281 ft.) or lower, up to 3000 m (9843 ft.) with derating
Vibration	10 to 20 Hz: 9.8 m/s ² (4□0477 to 4□0930: 5.9 m/s ²) 20 to 55 Hz: 5.9 m/s ² (2□0104 to 2□0248, 4□0096 to 4□0930: 2.0 m/s ²)
Orientation	Install the drive vertically to maintain maximum cooling effects.

<1> Attach a top protective cover and bottom cover from the optional End Cap Kit to an IP00/Open Type enclosure drive to convert the drive to an IP20/NEMA 1, UL Type 1 enclosure drive.

NOTICE: Avoid placing peripheral devices, transformers, or other electronics near the drive, as the noise created can lead to erroneous operation. Take proper steps to shield the drive from noise if such devices must be used in close proximity.

NOTICE: Prevent foreign matter such as metal shavings and wire clippings from falling into the drive during installation. Failure to comply could result in damage to the drive. Place a temporary cover over the top of the drive during installation. Remove the temporary cover before start-up, as the cover will reduce ventilation and cause overheat.

■ Harmonic Filter Module

Table 2.2 Harmonic Filter Module Installation Environment

Environment	Conditions
Installation Area	Indoors
Ambient Temperature	IP00/Open Type enclosure: -10 °C to +50 °C (14 °F to 122 °F) Harmonic filter module reliability improves in environments without wide temperature fluctuations. When using the harmonic filter module in an enclosure panel, install a cooling fan or air conditioner in the area to ensure that the air temperature inside the enclosure does not exceed the specified levels. Do not allow ice to develop on the harmonic filter module.
Humidity	95% RH or less and free of condensation
Storage Temperature	-20 °C to +60 °C (-4 °F to +104 °F)
Surrounding Area	Install the drive in an area free from: <ul style="list-style-type: none"> • oil mist and dust • metal shavings, oil, water, or other foreign materials • radioactive materials • combustible materials (e.g., wood) • harmful gases and liquids • excessive vibration • chlorides • direct sunlight.
Altitude	1000 m (3281 ft.) or lower, up to 3000 m (9843 ft.) with derating
Vibration	10 to 20 Hz: 5.9 m/s ² 20 to 55 Hz: 2.0 m/s ²
Orientation	Install the harmonic filter module vertically to maintain maximum cooling effects.

NOTICE: Avoid placing peripheral devices, transformers, or other electronics near the harmonic filter module, as the noise created can lead to erroneous operation. Take proper steps to shield the harmonic filter module from noise if such devices must be used in close proximity.

NOTICE: Prevent foreign matter such as metal shavings and wire clippings from falling into the harmonic filter module during installation. Failure to comply could result in damage to the harmonic filter module. Place a temporary cover over the top of the harmonic filter module during installation. Remove the temporary cover before start-up, as the cover will reduce ventilation and cause overheating.

◆ Installation Orientation and Spacing

NOTICE: Install the drive upright as illustrated in [Figure 2.1](#). Failure to comply may damage the drive due to improper cooling.

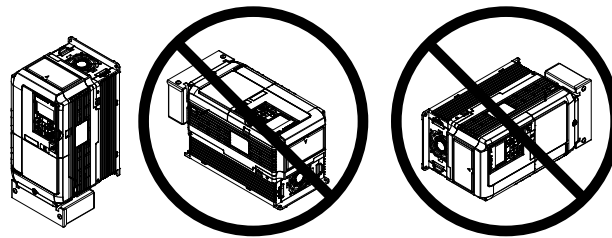

Figure 2.1 Correct Installation Orientation

NOTICE: Install the drive upright as specified in the manual. Failure to comply may damage the drive due to improper cooling.

2.2 Mechanical Installation

Single Drive Installation

Figure 2.2 and Figure 2.3 show the installation distance required to maintain sufficient space for airflow and wiring.

Drive Models 2□0028 to 2□0248 and 4□0011 to 4□0590

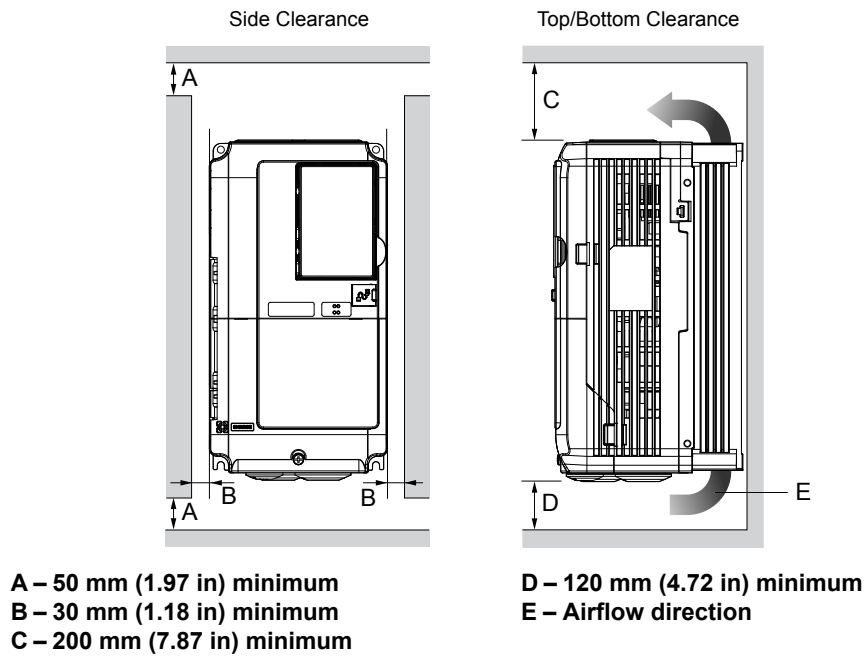

Figure 2.2 Correct Drive Installation Spacing

Drive Models 4□0720 to 4□0930 and Harmonic Filter Module

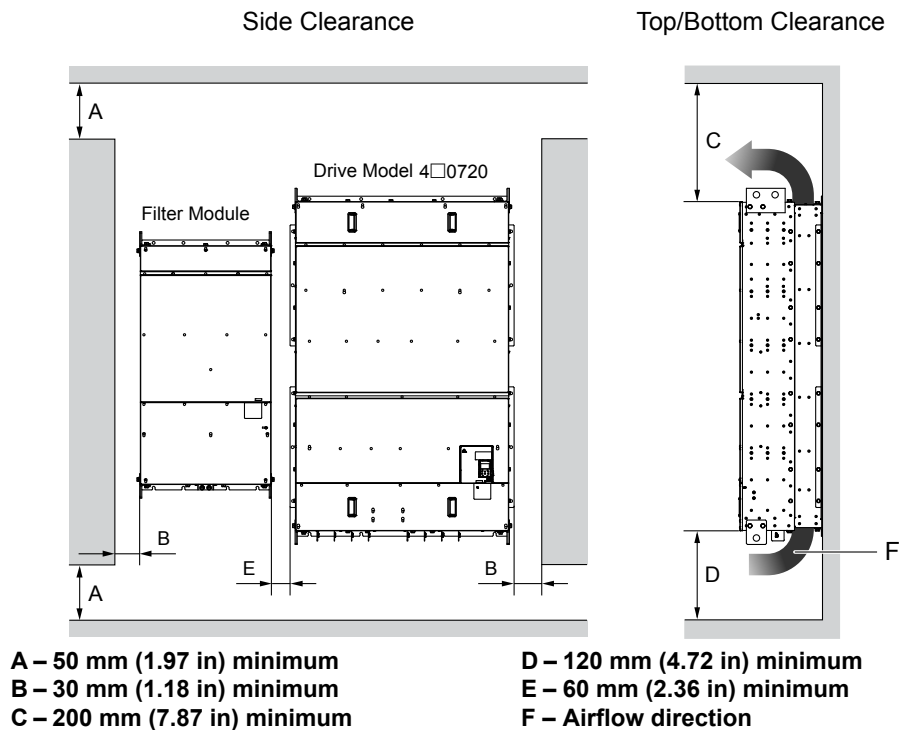

Figure 2.3 Correct Drive Model 4□0720 and Harmonic Filter Module Installation Spacing

◆ Instructions on Installation Using the Eye Bolts and Hanging Brackets

Eye bolts and hanging brackets are used to install the drive or to temporarily lift the drive during drive replacement. Using the eye bolts and hanging brackets, the drive can be installed in an enclosure panel or on a wall. Do not leave the drive suspended by the wires in a horizontal or vertical position for long periods of time. Do not transport the drive over long distances. Read the following precautions and instructions before installing the drive.

WARNING! Crush Hazard. Observe the following instructions and precautions. Failure to comply could result in serious injury or death from falling equipment.

Only use vertical suspension to temporarily lift the drive during installation to an enclosure panel. Do not use vertical suspension to transport the drive.

Confirm that the spring washer is completely closed prior to lifting to prevent damage to the drive.

Use screws to securely affix the drive front cover, terminal blocks, and other drive components prior to vertical suspension.

Do not subject the drive to vibration or impact greater than 1.96 m/s^2 (0.2 G) while it is suspended by the wires.

Do not leave the drive unattended while it is suspended by the wires.

Do not attempt to flip the drive over while it is suspended by the wires.

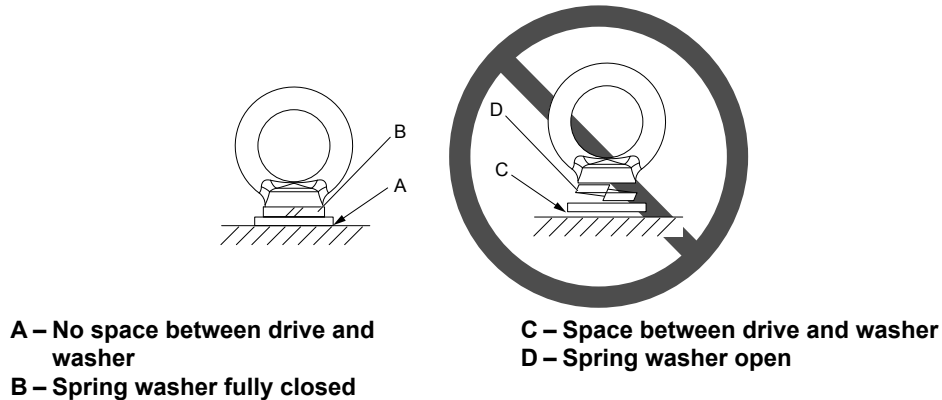

Figure 2.4 Spring Washer

■ Horizontal Suspension of Drive Models 2□0154 to 2□0248, 4□0156 to 4□0930, and Harmonic Filter Module

To make a wire hanger or frame for use when lifting the drive with a crane, lay the drive in a horizontal position and pass a wire through the hanging brackets.

NOTICE: Use the hanging brackets on the top and hanging holes of the bottom cover when lifting drive models 2□0154F, 2□0192F, 4□0156F, and 4□0180F.

2.2 Mechanical Installation

2□0154A, 2□0192A, 2□0248,

4□0156A, 4□0180A, and 4□0216 to 4□0590,

4□0720A to 4□0930A,

and Filter Module

2□0154F, 2□0192F, 4□0156F, and 4□0180F

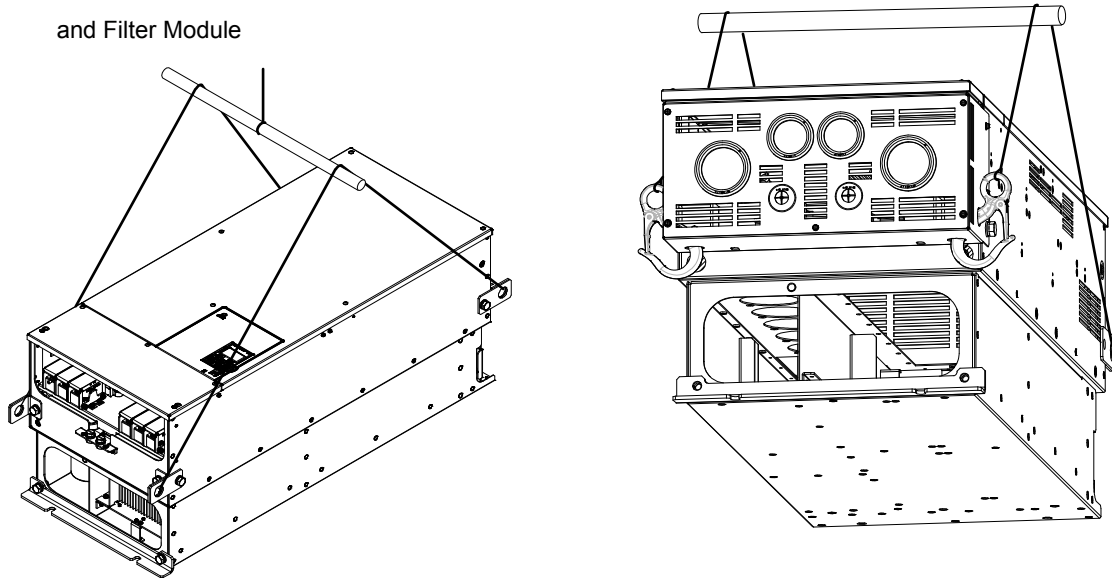

Figure 2.5 Horizontal Suspension of Drive Model 2□0154

■ Vertical Suspension of the Drive and Harmonic Filter Module

Follow the procedure described below when suspending the drive or harmonic filter module with eye bolts or hanging brackets.

Drive Models 2□0028 to 2□0130 and 4□0011 to 4□0124

WARNING! Crush Hazard. Use an adequate length of wire to ensure a 50° or wider suspension angle as illustrated in [Figure 2.6](#). The maximum allowable load of the eye bolts cannot be guaranteed when the drive or harmonic filter module is suspended with the wires at angles less than 50°. Failure to comply may result in serious injury or death from falling equipment.

1. Pass wire through the holes of the two eye bolts.

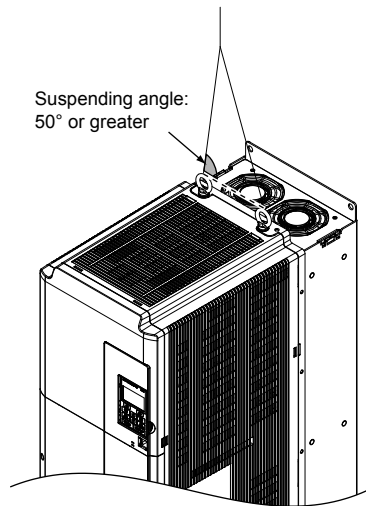

Figure 2.6 Suspension Using Wires and Eye Bolts

2. Gradually take up the slack in the wires and hoist the drive or harmonic filter module after the wires are stretched tight.
3. Lower the drive when ready to install in the enclosure panel. Stop lowering when near the floor, then slowly begin lowering the drive or again until the drive is placed correctly.

Drive Models 2□0154 to 2□0248 and 4□0156 to 4□0414

WARNING! Crush Hazard. Use an adequate length of wire to ensure a 50° or wider suspension angle as illustrated in [Figure 2.7](#). The maximum allowable load of the eye bolts cannot be guaranteed when the drive is suspended with the wires at angles less than 50°. Failure to comply may result in serious injury or death from falling equipment.

1. Remove the two hanging brackets from the drive lower side panels and bolt them on the top panel.

Note: Tighten the hanging brackets with the specified tightening torque: M10: 18 to 23 N·m (159 to 204 in-lb), M12: 32 to 40 N·m (283 to 354 in-lb).

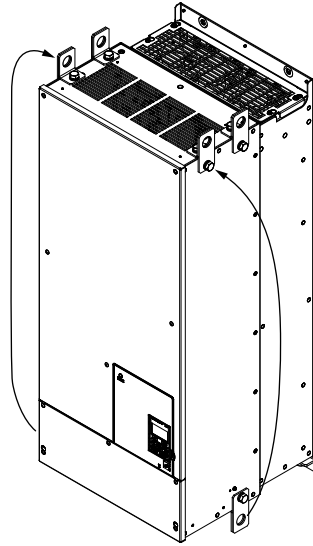

Figure 2.7 Location of Hanging Brackets (Drive Models 2□0154 to 2□0248 and 4□0156 to 4□0414)

2. Pass wire through the holes of all four hanging brackets.

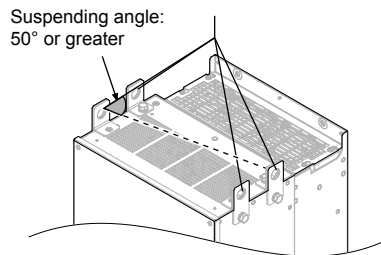

Figure 2.8 Drive Suspension Using Wires and Hanging Brackets (Drive Models 2□0154 to 2□0248 and 4□0156 to 4□0414)

3. Gradually take up the slack in the wires and hoist the drive after the wires are stretched tight.
4. Lower the drive when ready to install in the enclosure panel. Stop lowering the drive when it is near the floor, then slowly begin lowering the drive again until the drive is placed correctly.

Drive Models 4□0477 to 4□0930

1. Pass wire through the holes of all four hanging brackets.

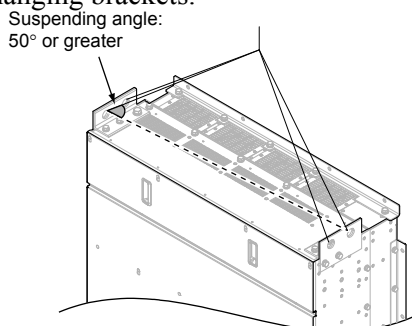

Figure 2.9 Drive Suspension Using Wires and Hanging Brackets (Models 4□0477 to 4□0930)

2.2 Mechanical Installation

2. Gradually take up the slack in the wires and hoist the drive after the wires are stretched tight.
3. Lower the drive when ready to install in the enclosure panel. Stop lowering the drive when it is near the floor, then slowly begin lowering the drive again very slowly until the drive is placed correctly.

Harmonic Filter Module

1. Pass wire through the holes of all four hanging brackets.

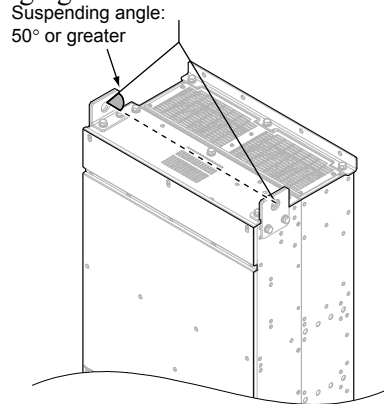

Figure 2.10 Harmonic Filter Module Suspension Using Wires and Hanging Brackets (EUJ7118□□□□)

2. Gradually take up the slack in the wires and hoist the harmonic filter module after the wires are stretched tight.
3. Lower the harmonic filter module when ready to install in the enclosure panel. Stop lowering the harmonic filter module when it is near the floor, then slowly begin lowering the harmonic filter module again very slowly until the harmonic filter module is placed correctly.

◆ HOA Keypad Remote Usage

■ Remote Operation

The HOA keypad mounted on the drive can be removed and connected to the drive using an extension cable up to 3 m (9.8 ft.) long to facilitate operation when the drive is installed in a location where it can not be easily accessed.

The HOA keypad can also be permanently mounted remote locations such as panel doors using an extension cable and an installation support set (depending on the installation type).

Note: Refer to *Peripheral Devices & Options on page 291* for information on extension cables and installation support sets.

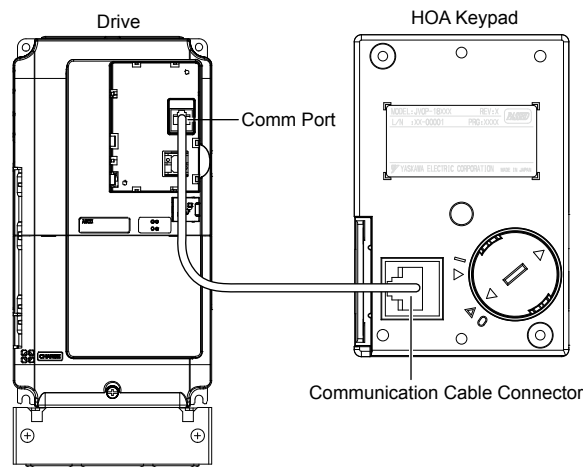

Figure 2.11 Communication Cable Connection

HOA Keypad Remote Installation

HOA Keypad Dimensions

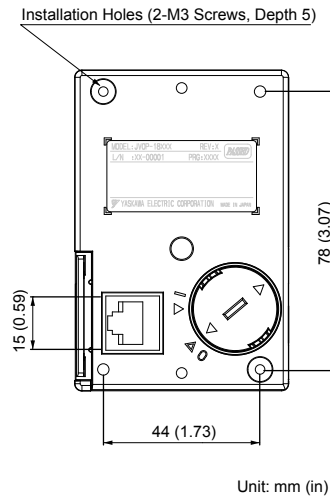

Figure 2.12 HOA Keypad Dimensions

Installation Types and Required Materials

The HOA keypad mounts to an enclosure two different ways:

- **External/face-mount** installs the HOA keypad outside the enclosure panel
- **Internal/flush-mount** installs the HOA keypad inside the enclosure panel

Table 2.3 HOA Keypad Installation Methods and Required Tools

Installation Method	Description	Installation Support Sets	Model	Required Tools
External/ Face-Mount	Simplified installation with the HOA keypad is mounted on the outside of the panel with two screws.	-	-	Phillips screwdriver (#1)
Internal/ Flush-Mount	Encloses the HOA keypad in the panel. The front of the HOA keypad is flush with the outside of the panel.	Installation Support Set A (for mounting with screws through holes in the panel)	EZZ020642A	Phillips screwdriver (#1, #2)
		Installation Support Set B (for use with threaded studs that are fixed to the panel)	EZZ020642B	Phillips screwdriver (#1) Wrench (7 mm)

NOTICE: Prevent foreign matter such as metal shavings or wire clippings from falling into the drive during installation and project construction. Failure to comply could result in damage to the drive. Place a temporary cover over the top of the drive during installation. Remove the temporary cover before drive start-up, as the cover will reduce ventilation and cause the drive to overheat.

External/Face-Mount

1. Cut an opening in the enclosure panel for the HOA keypad as shown in [Figure 2.13](#).
2. Position the HOA keypad so the display faces outwards, and mount it to the enclosure panel as shown in [Figure 2.14](#).

2.2 Mechanical Installation

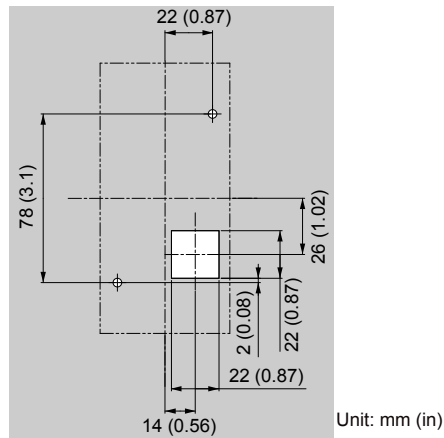

Figure 2.13 Panel Cut-Out Dimensions (External/Face-Mount Installation)

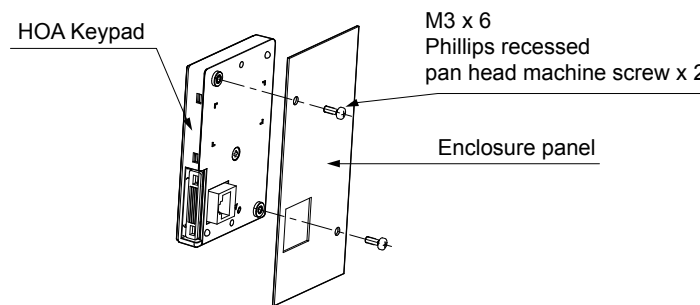

Figure 2.14 External/Face-Mount Installation

Internal/Flush-Mount

An internal/flush-mount requires an installation support set that must be purchased separately. Contact Yaskawa to order an installation support set and mounting hardware. **Figure 2.15** illustrates how to attach the Installation Support Set A.

1. Cut an opening in the enclosure panel for the HOA keypad as shown in **Figure 2.16**.
2. Mount the HOA keypad to the installation support.
3. Mount the installation support set and HOA keypad to the enclosure panel.

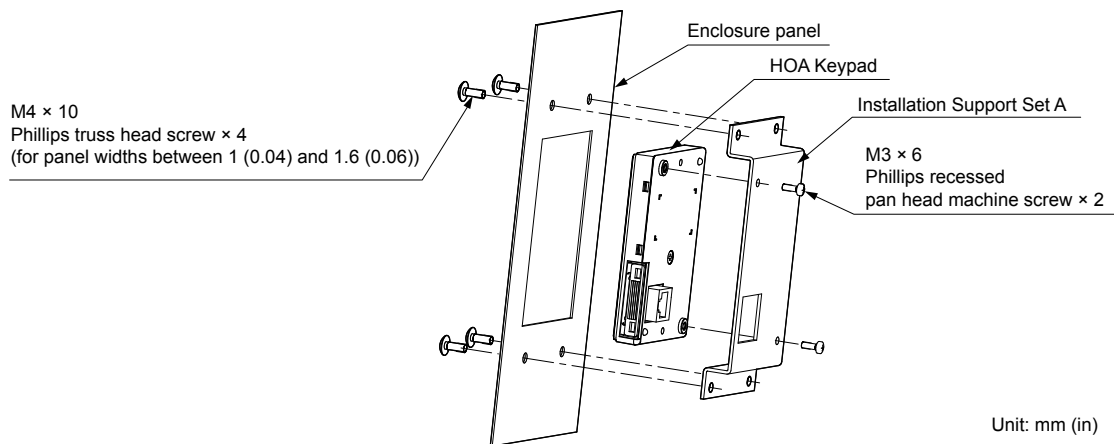

Figure 2.15 Internal/Flush Mount Installation

Note: Use a gasket between the enclosure panel and the HOA keypad in environments with a significant amount of dust or other airborne debris.

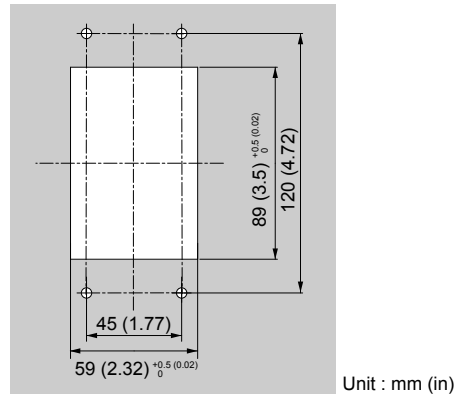

Figure 2.16 Panel Cut-Out Dimensions (Internal/Flush-Mount Installation)

◆ Exterior and Mounting Dimensions

■ Drive Models 2□0028□ to 2□0248□ and 4□0011□ to 4□0930□

Table 2.4 Drive Models and Types

Protective Design	Drive Model		Page
	Three-Phase 200 V Class	Three-Phase 400 V Class	
IP00 Enclosure	2□0028A 2□0042A 2□0054A 2□0068A 2□0081A 2□0104A 2□0130A 2□0154A 2□0192A 2□0248A	4□0011A 4□0014A 4□0021A 4□0027A 4□0034A 4□0040A 4□0052A 4□0065A 4□0077A 4□0096A 4□0124A 4□0156A 4□0180A 4□0216A 4□0240A 4□0302A 4□0361A 4□0414A	55
	—	4□0477A 4□0590A 4□0720A 4□0930A	57

2.2 Mechanical Installation

Protective Design	Drive Model		Page
	Three-Phase 200 V Class	Three-Phase 400 V Class	
IP20/NEMA 1, UL Type 1 Enclosure </>	2□0028F 2□0042F 2□0054F 2□0068F 2□0081F 2□0104F 2□0130F 2□0154F 2□0192F 2□0248F	4□0011F 4□0014F 4□0021F 4□0027F 4□0034F 4□0040F 4□0052F 4□0065F 4□0077F 4□0096F 4□0124F 4□0156F 4□0180F 4□0216F 4□0240F 4□0302F 4□0361F 4□0414F	59
	-	4□0477F 4□0590F	60

<1> Attach a top protective cover and bottom cover from the optional End Cap Kit to an IP00/Open Type enclosure drive to convert the drive to an IP20/NEMA 1, UL Type 1 enclosure drive.

IP00 Enclosure Drives

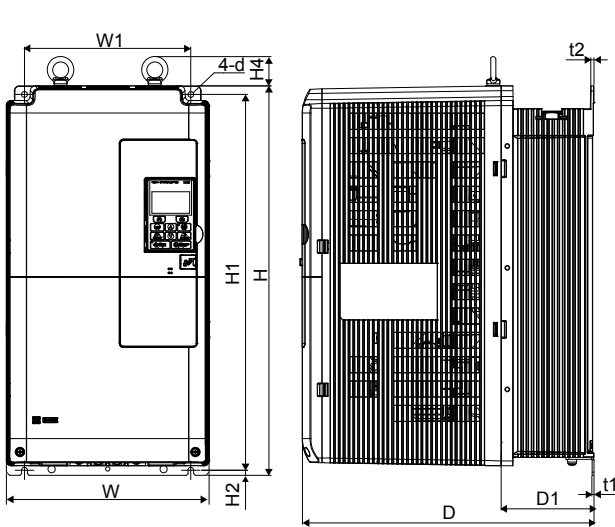

Figure 1

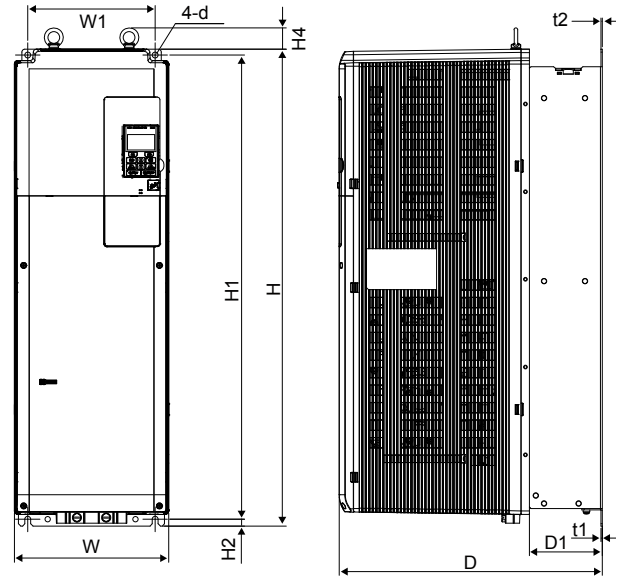

Figure 2

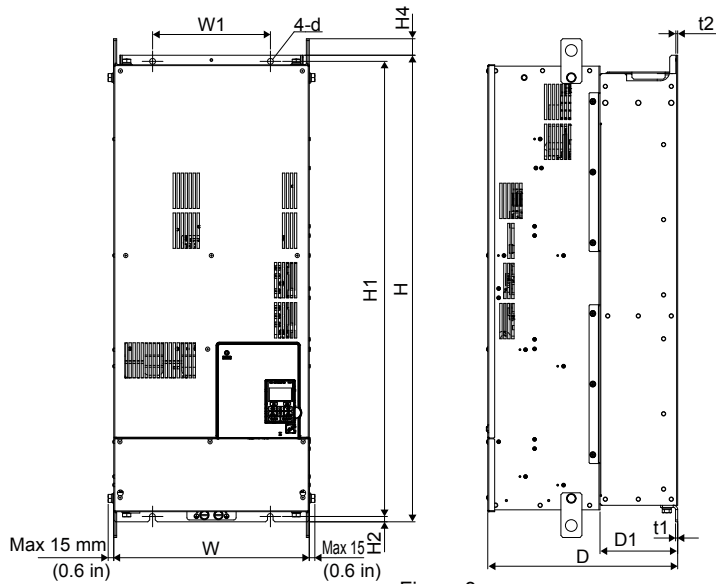

Figure 3

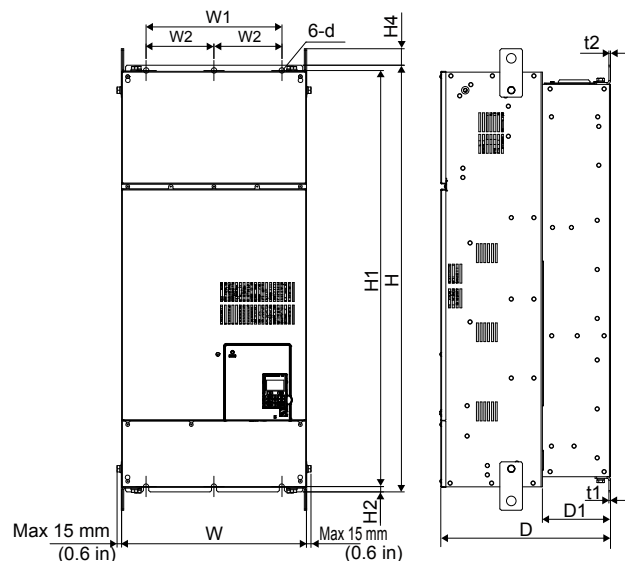

Figure 4

Table 2.5 Dimensions for IP00 Enclosure: 200 V Class

Drive Model	Figure	Dimensions mm (in)												Wt. kg (lb)
		W	H	D	W1	W2	H1	H2	H4	D1	t1	t2	d	
2□0028A	1	250 (9.84)	480 (18.89)	360 (14.17)	205 (8.07)	-	463 (18.22)	6.5 (0.25)	40 (1.58)	100 (3.93)	2.3 (0.10)	4 (0.16)	7 (0.28)	20 (44)
2□0042A		264 (10.39)	650 (25.60)	420 (16.53)	218 (8.58)	-	629 (24.73)	11.5 (0.45)	40 (1.58)	115.5 (4.54)	2.3 (0.10)	4 (0.16)	10 (0.40)	32 (71)
2□0054A		264 (10.39)	650 (25.60)	420 (16.53)	218 (8.58)	-	629 (24.73)	11.5 (0.45)	40 (1.58)	115.5 (4.54)	2.3 (0.10)	4 (0.16)	10 (0.40)	35 (77)
2□0068A		264 (10.39)	650 (25.60)	420 (16.53)	218 (8.58)	-	629 (24.73)	11.5 (0.45)	40 (1.58)	115.5 (4.54)	2.3 (0.10)	4 (0.16)	10 (0.40)	35 (77)
2□0081A		264 (10.39)	650 (25.60)	420 (16.53)	218 (8.58)	-	629 (24.73)	11.5 (0.45)	40 (1.58)	115.5 (4.54)	2.3 (0.10)	4 (0.16)	10 (0.40)	35 (77)
2□0104A	2	264 (10.39)	816 (32.12)	450 (17.71)	218 (8.58)	-	795 (31.29)	11.5 (0.45)	40 (1.58)	124.5 (4.90)	2.3 (0.10)	2.3 (0.10)	10 (0.40)	60 (132)
2□0130A		264 (10.39)	816 (32.12)	450 (17.71)	218 (8.58)	-	795 (31.29)	11.5 (0.45)	40 (1.58)	124.5 (4.90)	2.3 (0.10)	2.3 (0.10)	10 (0.40)	60 (132)
2□0154A	3	415 (16.33)	900 (38.97)	403 (15.86)	250 (9.84)	-	966 (38.03)	11 (0.43)	40 (1.58)	165 (6.49)	4.5 (0.18)	3.9 (0.15)	12 (0.47)	110 (245)
2□0192A		415 (16.33)	900 (38.97)	403 (15.86)	250 (9.84)	-	966 (38.03)	11 (0.43)	40 (1.58)	165 (6.49)	4.5 (0.18)	3.9 (0.15)	12 (0.47)	110 (245)
2□0248A	4	490 (19.29)	1132 (44.56)	450 (17.71)	360 (14.17)	180 (7.08)	1104 (43.46)	14.5 (0.57)	49 (1.92)	181 (7.12)	4.5 (0.18)	4.5 (0.18)	14 (0.55)	176 (388)

2.2 Mechanical Installation

Table 2.6 Dimensions for IP00 Enclosure: 400 V Class

Drive Model	Figure	Dimensions mm (in)												Wt. kg (lb)
		W	H	D	W1	W2	H1	H2	H4	D1	t1	t2	d	Models 4A□
4□0011A	1	250 (9.84)	480 (18.89)	360 (14.17)	205 (8.07)	-	463 (18.22)	6.5 (0.25)	40 (1.58)	100 (3.93)	2.3 (0.10)	4 (0.16)	7 (0.28)	20 (44)
4□0014A														
4□0021A														
4□0027A														
4□0034A		264 (10.39)	650 (25.60)	420 (16.53)	218 (8.58)	-	629 (24.73)	11.5 (0.45)	40 (1.57)	115.5 (4.54)	2.3 (0.10)	4 (0.16)	10 (0.40)	32 (71)
4□0040A														
4□0052A														
4□0065A														
4□0077A	2	264 (10.39)	816 (32.12)	450 (17.71)	218 (8.58)	-	795 (31.29)	11.5 (0.45)	40 (1.57)	124.5 (4.90)	2.3 (0.10)	2.3 (0.10)	10 (0.28)	60 (132)
4□0096A														
4□0124A	3	415 (16.33)	990 (38.97)	403 (15.86)	250 (9.84)	-	966 (38.03)	11 (0.43)	40 (1.57)	165 (6.49)	4.5 (0.18)	3.9 (0.15)	12 (0.47)	110 (245)
4□0156A														
4□0180A	4	490 (19.29)	1132 (44.56)	450 (17.71)	360 (14.17)	180 (7.08)	1104 (43.46)	14.5 (0.57)	49 (1.92)	181 (7.12)	4.5 (0.18)	4.5 (0.18)	14 (0.55)	176 (388)
4□0216A														
4□0240A		695 (27.36)	1132 (44.56)	450 (17.71)	560 (22.04)	280 (11.02)	1102 (43.39)	14.5 (0.57)	65 (2.55)	178 (7.00)	4.5 (0.18)	4.5 (0.18)	14 (0.55)	259 (571)
4□0302A														
4□0361A														
4□0414A														

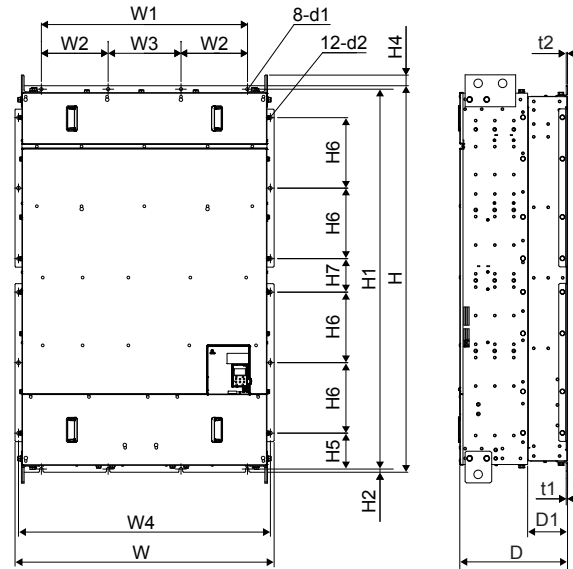

Figure 5

Table 2.7 Dimensions for IP00 Enclosure: 400 V Class

Drive Model	Figure	Dimensions mm (in)																		Wt. kg (lb)
		W	H	D	W1	W2	W3	W4	H1	H2	H4	H5	H6	H7	D1	t1	t2	d1	d2	
4□0477A	5	1070	1595	445	850	275	300	1040	1568	13	50	148	291	138.5	163	4.5	4.5	14	15	560
4□0590A		(42.13)	(62.80)	(17.52)	(33.46)	(10.83)	(11.81)	(40.94)	(61.73)	(0.51)	(1.97)	(5.83)	(11.46)	(5.45)	(6.42)	(0.18)	(0.18)	(0.55)	(0.59)	(1235)
4□0720A	6	1210	1835	445	1000	280	440	1180	1808	13	50	176.5	291	291	150	4.5	4.5	14	15	630
4□0930A		(47.64)	(72.24)	(17.52)	(39.37)	(11.02)	(17.32)	(46.46)	(71.18)	(0.51)	(1.97)	(6.95)	(11.46)	(11.46)	(5.91)	(0.18)	(0.18)	(0.55)	(0.59)	(1389)

IP20/NEMA 1, UL Type 1 Kit Selection

Customers may convert IP00/Open Type models to IP20/NEMA 1, UL Type 1 enclosures. Refer to [Table 2.8](#) to select the appropriate IP20/NEMA 1, UL Type 1 Kit when performing the conversion.

Contact a Yaskawa representative for IP20/NEMA 1, UL Type 1 Kit availability for IP00/Open Type models not listed.

Table 2.8 IP20/NEMA 1, UL Type 1 Kit Selection (240 V 3-Phase)

IP00/Open Type Drive Model	IP20/NEMA 1, UL Type 1 Kit Code
2A0028A	EZZ022745A
2A0042A	EZZ022745B
2A0054A	
2A0068A	
2A0081A	
2A0104A	EZZ022745C
2A0130A	
2A0154A	EZZ022745D
2A0192A	
2A0248A	EZZ022745E

Table 2.9 IP20/NEMA 1, UL Type 1 Kit Selection (400 V 3-Phase)

IP00/Open Type Drive Model	IP20/NEMA 1, UL Type 1 Kit Code
4A0011A	EZZ022745A
4A0014A	
4A0021A	
4A0027A	
4A0034A	

2.2 Mechanical Installation

IP00/Open Type Drive Model	IP20/NEMA 1, UL Type 1 Kit Code
4A0040A	EZZ022745B
4A0052A	
4A0065A	
4A0077A	
4A0096A	EZZ022745C
4A0124A	
4A0156A	EZZ022745D
4A0180A	
4A0216A	EZZ022745E
4A0302A	
4A0302A	EZZ022745F
4A0361A	
4A0414A	
4A0477A	EZZ022745G
4A0590A	

IP20/NEMA 1, UL Type 1 Enclosure Drives

Attach a top protective cover and bottom cover from the optional End Cap Kit to an IP00/Open Type enclosure drive to convert the drive to an IP20/NEMA 1, UL Type 1 enclosure drive.

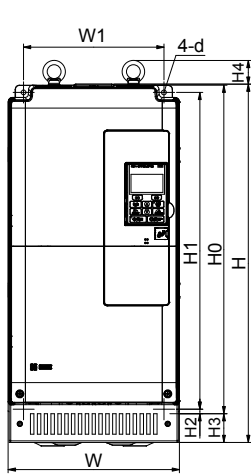

Figure 1

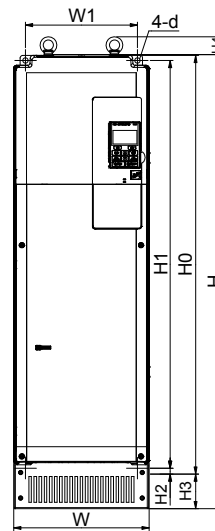
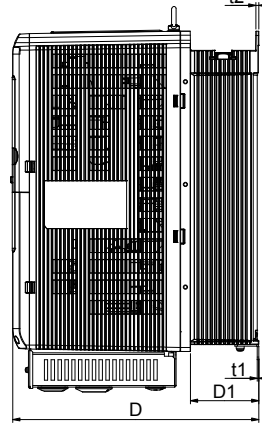

Figure 2

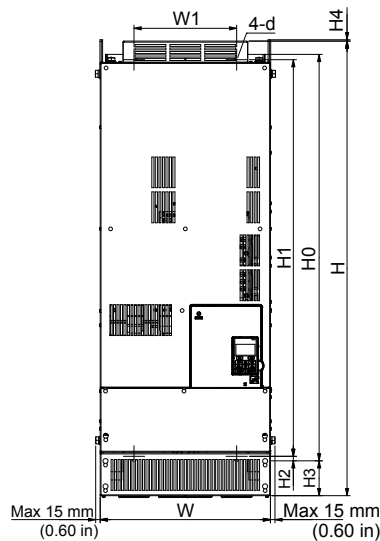
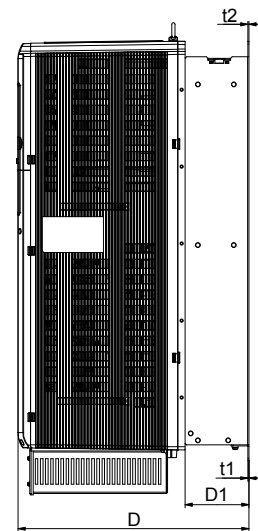

Figure 3

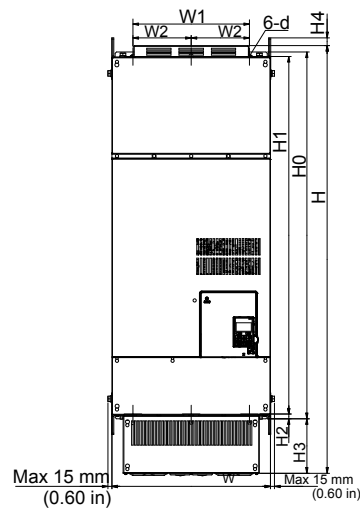
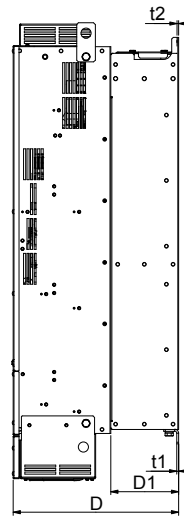

Figure 4

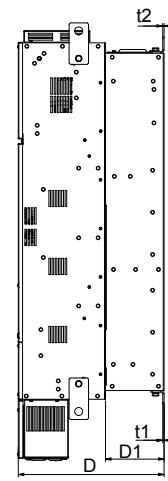

Table 2.10 Dimensions for IP20/NEMA 1, UL Type 1 Enclosure: 200 V Class

Drive Model	Figure	Dimensions mm (in)														Wt. kg (lb)
		W	H	D	W1	W2	H0	H1	H2	H3	H4	D1	t1	t2	d	
2□0028	1	250 (9.84)	524 (20.62)	360 (14.17)	205 (8.07)	-	480 (1890)	463 (18.22)	6.5 (0.25)	42 (1.65)	40 (1.58)	100 (3.93)	2.3 (0.10)	4 (0.16)	7 (0.28)	21.5 (47)
2□0042		264 (10.39)	705 (27.75)	420 (16.53)	218 (8.58)	-	650 (25.59)	629 (24.73)	11.5 (0.45)	54 (2.12)	40 (1.58)	115.5 (4.54)	2.3 (0.10)	4 (0.16)	10 (0.40)	34 (75)
2□0054		415 (16.33)	1107 (43.58)	403 (15.86)	250 (9.84)	-	990 (38.97)	966 (38.03)	11 (0.43)	85 (3.34)	8 (0.31)	165 (6.49)	4.5 (0.18)	3.9 (0.15)	12 (0.47)	113 (249)
2□0068		490 (19.29)	1320 (51.96)	450 (17.71)	360 (14.17)	180 (7.08)	1132 (44.56)	1104 (43.46)	14.5 (0.57)	169 (6.65)	29 (1.14)	181 (7.12)	4.5 (0.18)	4.5 (0.18)	14 (0.55)	180 (397)
2□0081	2	264 (10.39)	885 (34.84)	450 (17.71)	218 (8.58)	-	816 (32.12)	795 (31.29)	11.5 (0.45)	68 (2.67)	40 (1.58)	124.5 (4.90)	2.3 (0.10)	2.3 (0.10)	10 (0.40)	62 (137)
2□0104		264 (10.39)	885 (34.84)	450 (17.71)	218 (8.58)	-	816 (32.12)	795 (31.29)	11.5 (0.45)	68 (2.67)	40 (1.58)	124.5 (4.90)	2.3 (0.10)	2.3 (0.10)	10 (0.40)	62 (137)
2□0130	3	415 (16.33)	1107 (43.58)	403 (15.86)	250 (9.84)	-	990 (38.97)	966 (38.03)	11 (0.43)	85 (3.34)	8 (0.31)	165 (6.49)	4.5 (0.18)	3.9 (0.15)	12 (0.47)	113 (249)
2□0154		415 (16.33)	1107 (43.58)	403 (15.86)	250 (9.84)	-	990 (38.97)	966 (38.03)	11 (0.43)	85 (3.34)	8 (0.31)	165 (6.49)	4.5 (0.18)	3.9 (0.15)	12 (0.47)	113 (249)
2□0192	4	490 (19.29)	1320 (51.96)	450 (17.71)	360 (14.17)	180 (7.08)	1132 (44.56)	1104 (43.46)	14.5 (0.57)	169 (6.65)	29 (1.14)	181 (7.12)	4.5 (0.18)	4.5 (0.18)	14 (0.55)	180 (397)
2□0248		490 (19.29)	1320 (51.96)	450 (17.71)	360 (14.17)	180 (7.08)	1132 (44.56)	1104 (43.46)	14.5 (0.57)	169 (6.65)	29 (1.14)	181 (7.12)	4.5 (0.18)	4.5 (0.18)	14 (0.55)	180 (397)

2.2 Mechanical Installation

Table 2.11 Dimensions for IP20/NEMA 1, UL Type 1 Enclosure: 400 V Class

Drive Model	Figure	Dimensions mm (in)														Wt. kg (lb)	Models 4A□														
		W	H	D	W1	W2	H0	H1	H2	H3	H4	D1	t1	t2																	
4□0011	1	250 (9.84)	524 (20.62)	360 (14.17)	205 (8.07)	-	480 (18.90)	463 (18.22)	6.5 (0.25)	42 (1.65)	40 (1.58)	100 (3.93)	2.3 (0.10)	4 (0.15)	7 (0.27)	21.5 (47)															
4□0014																															
4□0021																															
4□0027																															
4□0034																															
4□0040																															
4□0052																	264 (10.39)	705 (27.75)	420 (16.53)	218 (8.58)	-	650 (22.59)	629 (24.73)	11.5 (0.45)	54 (2.12)	40 (1.57)	115.5 (4.55)	2.3 (0.10)	4 (0.15)	10 (0.40)	34 (75)
4□0065																															37 (82)
4□0077																															
4□0096	2	264 (10.39)	885 (34.84)	450 (17.71)	218 (8.58)	-	816 (32.12)	795 (31.29)	11.5 (0.45)	68 (2.67)	40 (1.57)	124.5 (4.90)	2.3 (0.10)	2.3 (0.10)	10 (0.40)	62 (137)															
4□0124																															
4□0156	3	415 (16.33)	1107 (43.58)	403 (15.86)	250 (9.84)	-	990 (38.97)	966 (38.03)	11 (0.43)	85 (3.34)	8 (0.31)	165 (6.49)	4.5 (0.18)	3.9 (0.15)	12 (0.47)	113 (249)															
4□0180																															
4□0216	4	490 (19.29)	1320 (51.96)	450 (17.71)	360 (14.17)	180 (7.08)	1132 (44.56)	1104 (43.46)	14.5 (0.57)	169 (6.65)	29 (1.14)	181 (7.12)	4.5 (0.18)	4.5 (0.18)	14 (0.55)	180 (398)															
4□0240																															
4□0302																	695 (27.36)	1460 (57.48)	450 (17.71)	560 (22.05)	280 (11.02)	1132 (44.56)	1102 (43.39)	14.5 (0.57)	300 (11.81)	29 (1.14)	178 (7.00)	4.5 (0.18)	4.5 (0.18)	14 (0.55)	270 (595)
4□0361																															
4□0414																															

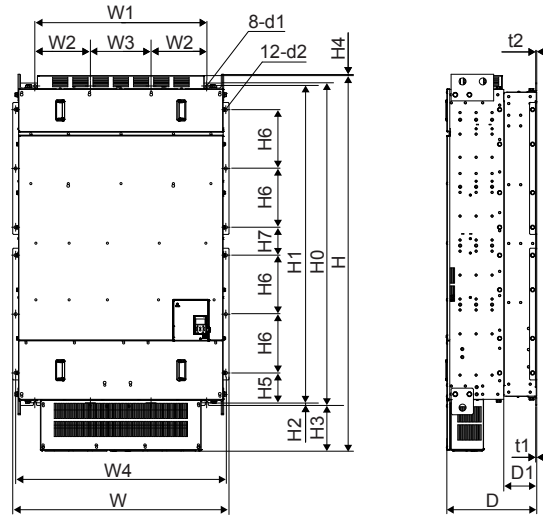

Figure 5

Table 2.12 Dimensions for IP20/UL Type 1 Enclosure: 400 V Class

Drive Model	Figure	Dimensions mm (in)									
		W	H	D	W1	W2	W3	W4	H0	H1	H2
4□0477F	5	1070 (42.13)	1853 (72.95)	445 (17.52)	850 (33.46)	275 (10.83)	300 (11.81)	1040 (40.94)	1595 (62.80)	1568 (61.73)	13 (0.51)
4□0590F											

Table 2.13 Dimensions for IP20/UL Type 1 Enclosure: 400 V Class (Continued)

Drive Model	Figure	Dimensions mm (in)										Wt. kg (lb)
		H3	H4	H5	H6	H7	D1	t1	t2	d	d2	
4□0477F	5	221 (8.70)	14 (0.55)	148 (5.83)	291 (11.46)	138.5 (5.45)	163 (6.42)	4.5 (0.18)	4.5 (0.18)	14 (0.55)	15 (0.59)	570 (1257)
4□0590F												

■ Harmonic Filter Module

Table 2.14 Harmonic Filter Module Models and Types for Models 4□0720 to 4□0930

Protective Design	Harmonic Filter Module Model Three-Phase 400 V Class
IP00 Enclosure	EUJ71180□.□ EUJ71182□.□

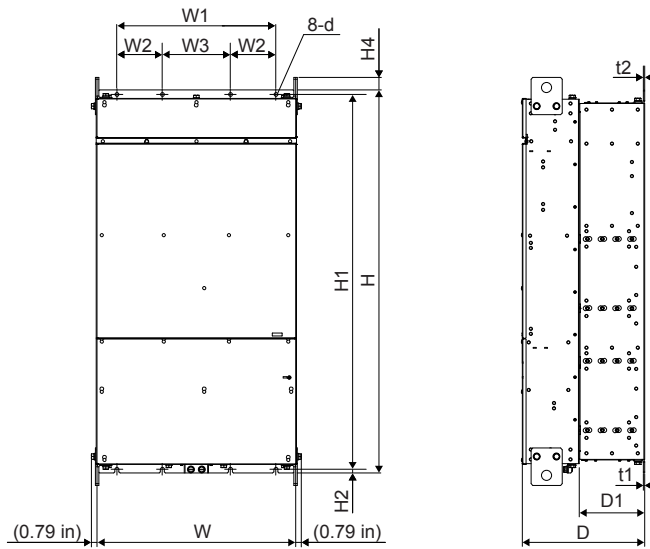

Table 2.15 Dimensions for IP00 Enclosure: Harmonic Filter Module for Models 4□0720 to 4□0930

Model	Dimensions mm (in)													Wt. kg (lb)
	W	H	D	W1	W2	W3	H1	H2	H4	D1	t1	t2	d	
EUJ71180□.□	700	1350	432	560	160	240	1321	13	50	231	4.5	4.5	14	345
EUJ71182□.□	(27.56)	(53.15)	(17.01)	(22.05)	(6.30)	(9.45)	(52.01)	(0.51)	(1.97)	(9.09)	(0.18)	(0.18)	(0.55)	(761)

This Page Intentionally Blank

Electrical Installation

This chapter explains proper procedures for wiring the control circuit terminals, motor, and power supply.

3.1	SECTION SAFETY.....	64
3.2	STANDARD CONNECTION DIAGRAM.....	66
3.3	MAIN CIRCUIT CONNECTION DIAGRAM.....	71
3.4	TERMINAL BLOCK CONFIGURATION.....	72
3.5	TERMINAL COVER.....	77
3.6	HOA KEYPAD AND FRONT COVER.....	80
3.7	TOP PROTECTIVE COVER.....	83
3.8	MAIN CIRCUIT WIRING.....	84
3.9	CONTROL CIRCUIT WIRING.....	94
3.10	CONTROL I/O CONNECTIONS.....	102
3.11	CONNECT TO A PC.....	107
3.12	WIRING CHECKLIST.....	108

3.1 Section Safety

DANGER

Electrical Shock Hazard

Before servicing, disconnect all power to the equipment.

The capacitor for the control power supply remains charged even after the power supply is turned off. The charge indicator LED will extinguish when the control power supply voltage is below 50 Vdc. To prevent electric shock, wait for at least the time specified on the warning label, once all indicators are OFF, measure for unsafe voltages to confirm the drive is safe prior to servicing.

Failure to comply will result in death or serious injury.

WARNING

Electrical Shock Hazard

Do not operate equipment with covers removed.

Failure to comply could result in death or serious injury.

The diagrams in this section may show drives without covers or safety shields to show details. Be sure to reinstall covers or shields before operating the drives and run the drives according to the instructions described in this manual.

Always use appropriate equipment for Ground Fault Circuit Interrupters (GFCIs).

The drive can cause a residual current with a DC component in the protective earthing conductor. Where a residual current operated protective or monitoring device is used for protection in case of direct or indirect contact, always use a type B GFCI according to IEC/EN 60755.

Always ground the motor-side grounding terminal.

Improper equipment grounding could result in death or serious injury by contacting the motor case.

Do not perform work on the drive while wearing loose clothing, jewelry or without eye protection.

Failure to comply could result in death or serious injury.

Remove all metal objects such as watches and rings, secure loose clothing, and wear eye protection before beginning work on the drive.

Do not remove covers or touch circuit boards while the power is on.

Failure to comply could result in death or serious injury.

Do not allow unqualified personnel to perform work on the drive.

Failure to comply could result in death or serious injury.

Installation, maintenance, inspection, and service must be performed only by authorized personnel familiar installation, adjustment, and maintenance of drives.

Do not touch any terminals before the capacitors have fully discharged.

Failure to comply could result in death or serious injury.

Before wiring terminals, disconnect all power to the equipment. The capacitor for the control power supply remains charged even after the power supply is turned off. After shutting off the power, wait for at least the amount of time specified on the drive before touching any components.

Fire Hazard

Tighten all terminal screws to the specified tightening torque.

Loose electrical connections could result in death or serious injury by fire due to overheating of electrical connections.

Failure to comply could result in death or serious injury by fire.

Attach the drive and harmonic filter module to metal or other noncombustible material.

⚠ WARNING**Do not use an improper voltage source.**

Failure to comply could result in death or serious injury by fire.

Verify that the rated voltage of the drive matches the voltage of the incoming power supply before applying power.

⚠ CAUTION**Do not carry the drive by the front cover or the terminal cover.**

Failure to comply may cause the main body of the drive to fall, resulting in minor or moderate injury.

NOTICE**Perform a final check of all sequence wiring and other connections prior to applying power.**

Failure to comply may cause erroneous operation or damage to the drive.

Ensure there are no short circuits on the control terminals.

Failure to comply may damage the drive.

Observe proper electrostatic discharge procedures (ESD) when handling the drive and circuit boards.

Failure to comply may result in ESD damage to the drive circuitry.

Never connect or disconnect the motor from the drive while the drive is outputting voltage.

Improper equipment sequencing could result in damage to the drive.

Do not use unshielded cable for control wiring.

Failure to comply may cause electrical interference resulting in poor system performance. Use shielded, twisted-pair wires and ground the shield to the ground terminal of the drive.

Use ring terminals that comply with UL/cUL for all wire ends.

Failure to comply may damage the drive.

Use only the tools recommended by the terminal manufacturer for crimping.

Failure to comply may damage the drive.

Do not allow unqualified personnel to use the product.

Failure to comply may damage the drive.

Carefully review instruction manual when connecting, wiring, or replacing the drive.

Do not modify the drive circuitry.

Failure to comply may damage the drive and will void warranty.

Yaskawa is not responsible for any modification of the product made by the user. This product must not be modified.

Check all the wiring to ensure that all connections are correct after installing the drive and connecting any other devices.

Failure to comply may damage the drive.

Comply with proper wiring practices

The motor may run in reverse if the phase order is incorrect.

Connect motor input terminals U, V, and W to drive output terminals U/T1, V/T2, and W/T3. The phase order for the drive and motor should match.

3.2 Standard Connection Diagram

Connect the drive and peripheral devices as shown in [Figure 3.1](#). It is possible to set and run the drive via the digital operator without connecting digital I/O wiring. This section does not discuss drive operation; [Refer to Start-Up Programming & Operation on page 111](#) for instructions on operating the drive.

Note: Drive models 4□0720 to 4□0930 require main circuit wiring and a connection to the module communications connector. [Refer to Module Communications Connector on page 99](#) for details.

WARNING! Sudden Movement Hazard. Do not close the wiring for the control circuit unless the multifunction input terminal parameters are properly set. Improper sequencing of run/stop circuitry could result in death or serious injury from moving equipment.

WARNING! Sudden Movement Hazard. Ensure start/stop and safety circuits are wired properly and in the correct state before energizing the drive. Failure to comply could result in death or serious injury from moving equipment. When programmed for 3-Wire control, a momentary closure on terminal S1 may cause the drive to start.

WARNING! Sudden Movement Hazard. When using a 3-Wire sequence, set the drive to 3-Wire sequence prior to wiring the control terminals and set parameter b1-17 to 0 so the drive will not accept a Run command at power up (default). If the drive is wired for a 3-Wire sequence but set up for a 2-Wire sequence (default), and parameter b1-17 is set to 1 so the drive accepts a Run command at power up, the motor will rotate in reverse direction at drive power up and may cause injury.

WARNING! Sudden Movement Hazard. Confirm the drive I/O signals and external sequence before executing the application preset function. Executing the application preset function or setting A1-06 ≠ 0 will change the drive I/O terminal functions and may cause unexpected equipment operation. Failure to comply may cause death or serious injury.

WARNING! When using the automatic fault restart function with wiring designed to shut off the power supply upon drive fault, make sure the drive does not trigger a fault output during fault restart (L5-02 = 0, default). Failure to comply will prevent the automatic fault restart function from working properly.

NOTICE: Inadequate wiring could result in damage to the drive. Install adequate branch circuit protection per applicable codes. The drive is suitable for use on a circuit capable of delivering not more than 100,000 RMS symmetrical amperes, 240 Vac maximum (200 V class) and 500 Vac maximum (400 V class: 4A□□□□) when protected by branch circuit protection devices specified in this document.

NOTICE: Do not connect AC control circuit ground to drive enclosure. Improper drive grounding can cause control circuit malfunction.

NOTICE: Route motor leads U/T1, V/T2, and W/T3 separate from all other leads to reduce possible interference related issues. Failure to comply may result in abnormal operation of drive and nearby equipment.

NOTICE: Correctly set Sink/Source jumper S3 for internal power supply. Failure to comply may result in damage to the drive.

Note: The minimum load for the relay outputs M1-M2, M3-M4, MD-ME-MF, and MA-MB-MC is 10 mA.

NOTICE: Create a sequence to shut off power on the power supply side by using a fault relay output as shown in the standard connection diagram, or create a sequence that prevents the motor shaft from being turned by an external force. If you continue to input power from a power supply with a large distortion or if an external force causes the motor shaft to continue turning even after an SoH (Snubber Discharge Resistor Overheat) occurs, the snubber resistor may break.

NOTICE: Do not connect more than one multi-function input to one terminal. Improper wiring may result in drive malfunction. Use an external power supply when sharing a terminal with more than one input. Do not use the built-in +24 V power supply.

◆ Drive Models 2□0028 to 2□0248 and 4□0011 to 4□0590

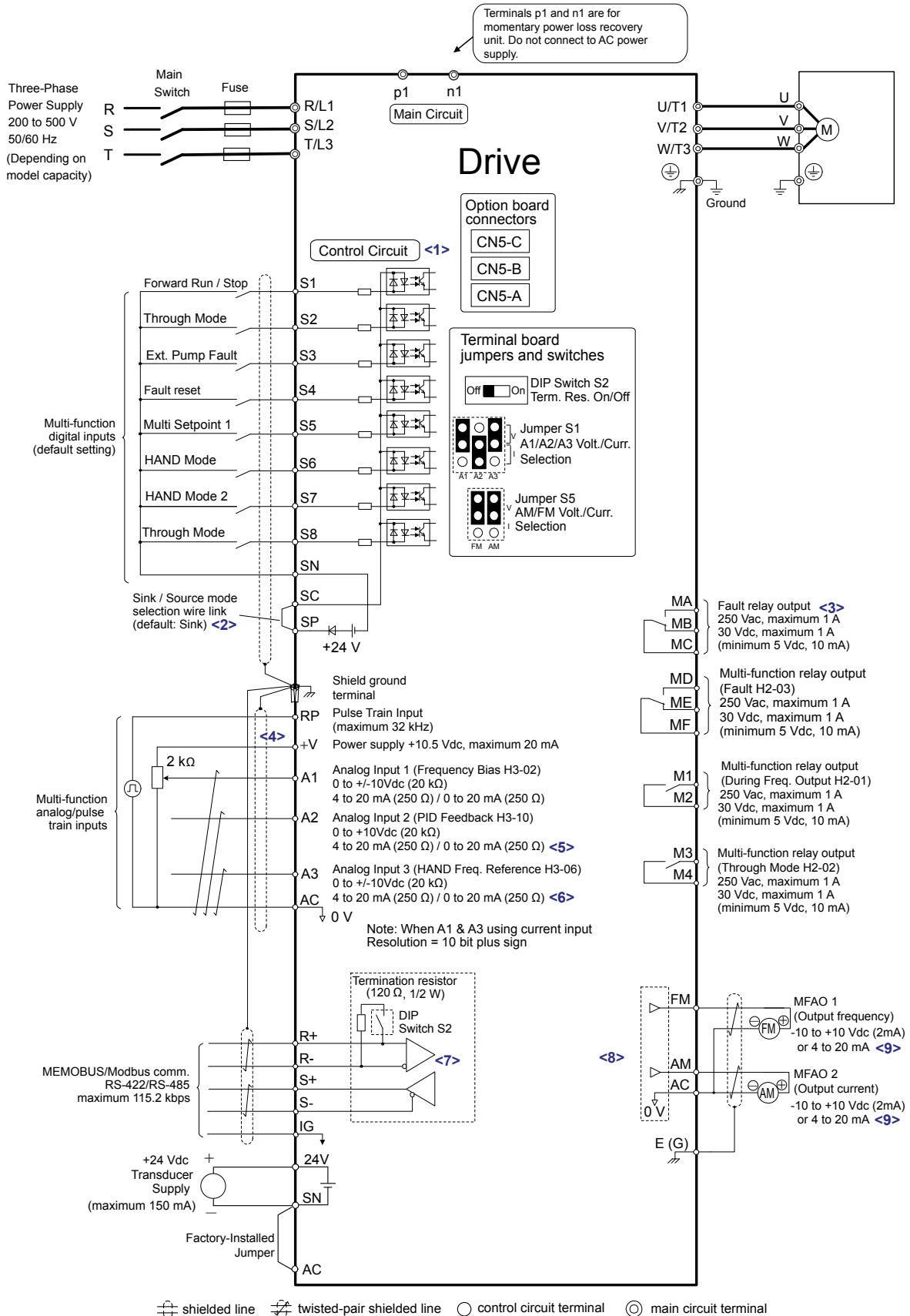

Figure 3.1 Drive Standard Connection Diagram (Example: Model 2□0028)

3.2 Standard Connection Diagram

- <1> Supplying power to the control circuit separately from the main circuit requires 24 V power supply (option).
- <2> This figure illustrates an example of a sequence input to S1 through S8 using a non-powered relay or an NPN transistor. Install the wire link between terminals SC-SP for Sink mode, between SC-SN for Source mode, or leave the link out for external power supply. Never short terminals SP and SN, as it will damage the drive. *Refer to Control I/O Connections on page 102* for details.
- <3> Wire the fault relay output separately from the main circuit power supply and other power lines.
- <4> The maximum output current capacity for the +V terminal on the control circuit is 20 mA. Never short terminals +V or AC, as it can cause erroneous operation or damage the drive.
- <5> Set jumper S1 to select between a voltage or current input signal to terminal A2. The default setting is for current input.
- <6> Set jumper S1 to select between a voltage or current input signal to terminal A1 and A3. The default setting is for current input.
- <7> Set DIP switch S2 to the ON position to enable the termination resistor in the last drive in a MEMOBUS/Modbus network.
- <8> Use jumper S5 to select between voltage or current output signals at terminals AM and FM. Set parameters H4-07 and H4-08 accordingly.
- <9> Monitor outputs work with devices such as analog frequency meters, ammeters, voltmeters, and wattmeters. They are not intended for use as a feedback-type signal.

◆ Drive Models 4□0720 to 4□0930

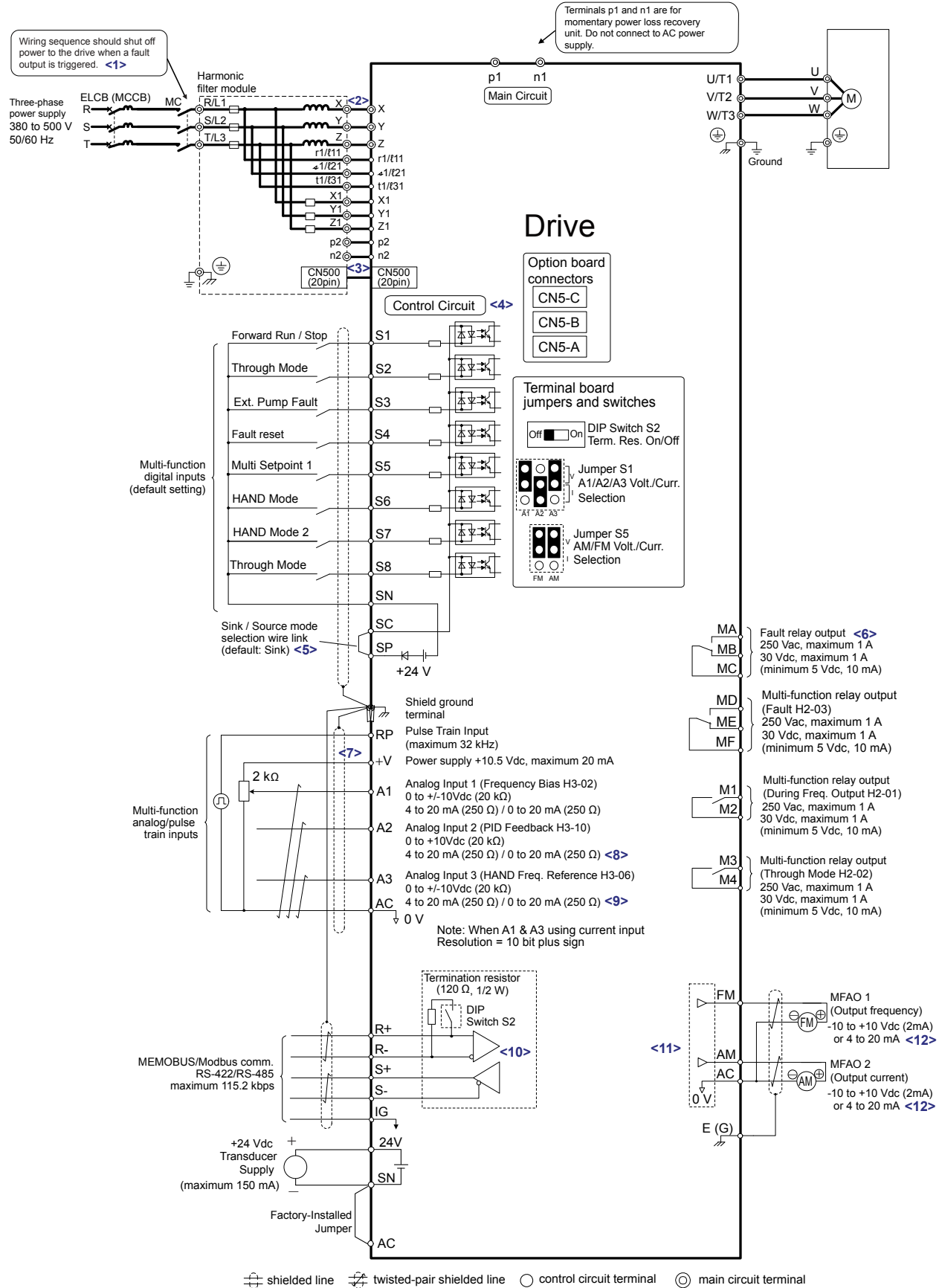

Figure 3.2 Drive Standard Connection Diagram (Example: Model 4□0720)

3.2 Standard Connection Diagram

- <1> When setting L5-02 to 1 to trigger a fault output whenever the fault restart function is activated, a sequence to interrupt power when a fault occurs will turn off power to the drive as the drive attempts to restart. The default setting for L5-02 is 0 (Fault output not active during restart attempt).
- <2> The cable between models 4□0720 to 4□0930 and the harmonic filter module should not exceed 5 m (16.4 ft.).
- <3> Wire module connector CN500 to connect the standard configuration device (harmonic filter module) before turning on or operating models 4□0720 to 4□0930.
- <4> Supplying power to the control circuit separately from the main circuit requires 24 V power supply (option).
- <5> This figure illustrates an example of a sequence input to S1 through S8 using a non-powered relay or an NPN transistor. Install the wire link between terminals SC-SP for Sink mode, between SC-SN for Source mode, or leave the link out for external power supply. Never short terminals SP and SN, as it will damage the drive. *Refer to Control I/O Connections on page 102* for details.
- <6> Wire the fault relay output separately from the main circuit power supply and other power lines.
- <7> The maximum output current capacity for the +V terminal on the control circuit is 20 mA. Never short terminals +V or AC, as it can cause erroneous operation or damage the drive.
- <8> Set jumper S1 to select between a voltage or current input signal to terminal A2. The default setting is for current input.
- <9> Set jumper S1 to select between a voltage or current input signal to terminal A1 and A3. The default setting is for current input.
- <10> Set DIP switch S2 to the ON position to enable the termination resistor in the last drive in a MEMOBUS/Modbus network.
- <11> Use jumper S5 to select between voltage or current output signals at terminals AM and FM. Set parameters H4-07 and H4-08 accordingly.
- <12> Monitor outputs work with devices such as analog frequency meters, ammeters, voltmeters, and wattmeters. They are not intended for use as a feedback-type signal.

3.3 Main Circuit Connection Diagram

Refer to [Figure 3.3](#) or [Figure 3.4](#) when wiring the main circuit of the drive.

◆ Drive Models 2□0028 to 2□0248 and 4□0011 to 4□0590

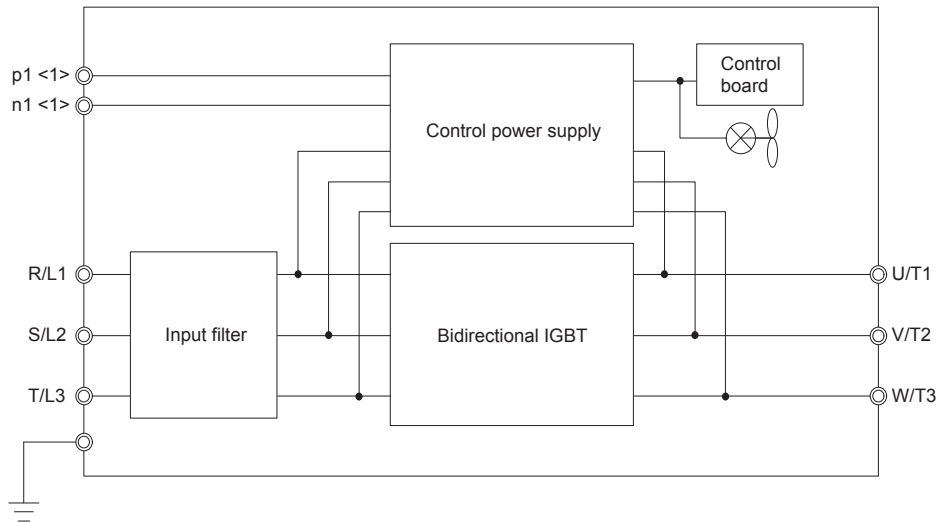

Figure 3.3 Connecting Main Circuit Terminals

<1> A Momentary Power Loss Recovery Unit can be connected as an option. Do not connect an AC power supply to these terminals.

◆ Drive Models 4□0720 to 4□0930 and Harmonic Filter Modules

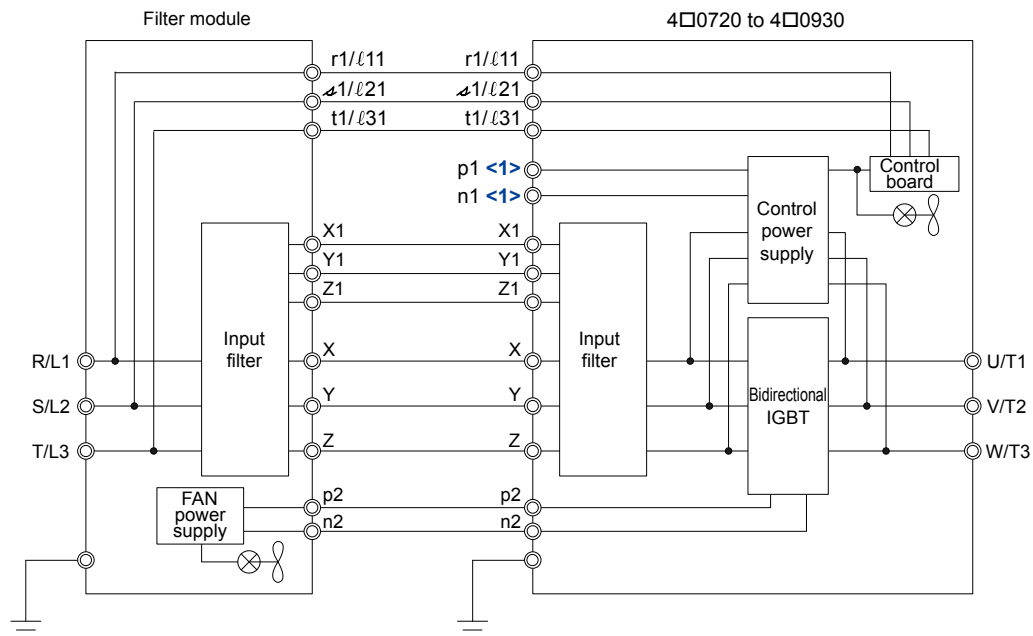

Figure 3.4 Connecting Main Circuit Terminals

<1> A Momentary Power Loss Recovery Unit can be connected as an option. Do not connect an AC power supply to these terminals.

3.4 Terminal Block Configuration

◆ Drive Models 2□0028 to 2□0248 and 4□0011 to 4□0930

Figure 3.5 to *Figure 3.12* show the different main circuit terminal arrangements for the drive capacities. Use *Table 3.1* to determine the correct figure based on drive model.

Table 3.1 Terminal Block Configuration

Voltage Class	Drive Model	Figure
200 V Class	2□0028	<i>Figure 3.5</i>
	2□0042	<i>Figure 3.6</i>
	2□0054	
	2□0068	
	2□0081	
	2□0104	
	2□0130	<i>Figure 3.7</i>
	2□0154	<i>Figure 3.8</i>
	2□0192	<i>Figure 3.9</i>
	2□0248	
400 V Class	4□0011	<i>Figure 3.5</i>
	4□0014	
	4□0021	
	4□0027	
	4□0034	
	4□0040	<i>Figure 3.6</i>
	4□0052	
	4□0065	
	4□0077	
	4□0096	
	4□0124	<i>Figure 3.7</i>
	4□0156	<i>Figure 3.8</i>
	4□0180	<i>Figure 3.9</i>
	4□0216	
	4□0240	
	4□0302	<i>Figure 3.10</i>
	4□0361	
	4□0414	
	4□0477	<i>Figure 3.11</i>
	4□0590	<i>Figure 3.12</i>
4□0720		
4□0930		

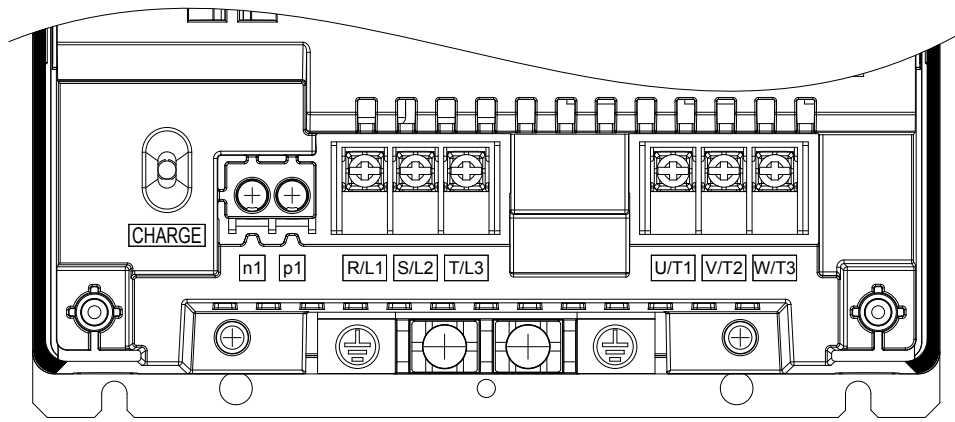

Figure 3.5 Main Circuit Terminal Configuration (Drive Models 2□0028 and 4□0011 to 4□0034)

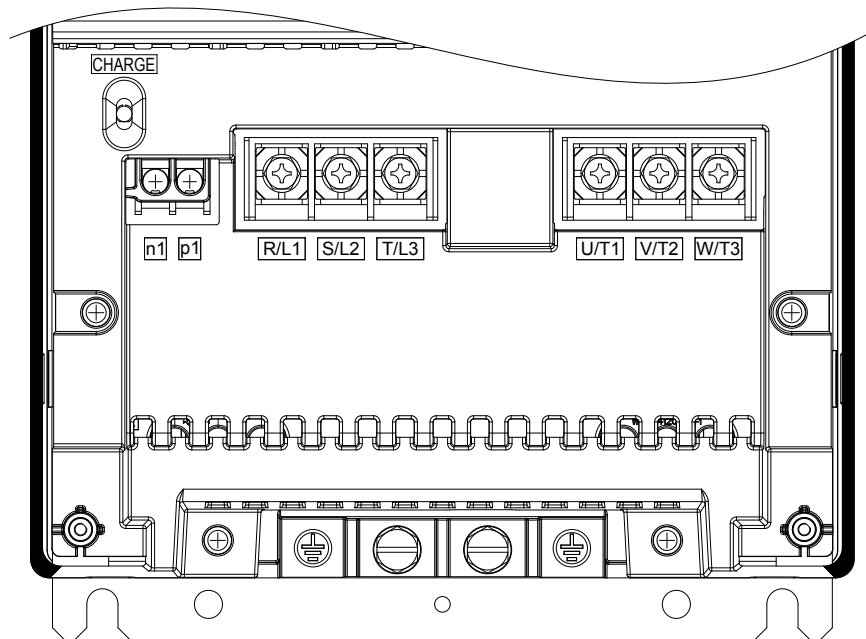

Figure 3.6 Main Circuit Terminal Configuration (Drive Models 2□0042 to 2□0081 and 4□0040 to 4□0077)

3.4 Terminal Block Configuration

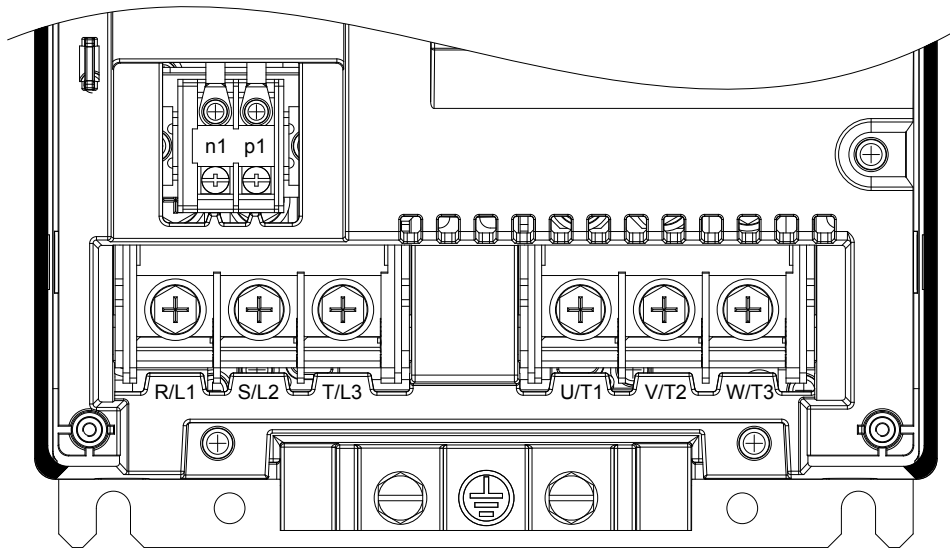

Figure 3.7 Main Circuit Terminal Configuration (Drive Models 2□0104, 2□0130, 4□0096, and 4□0124)

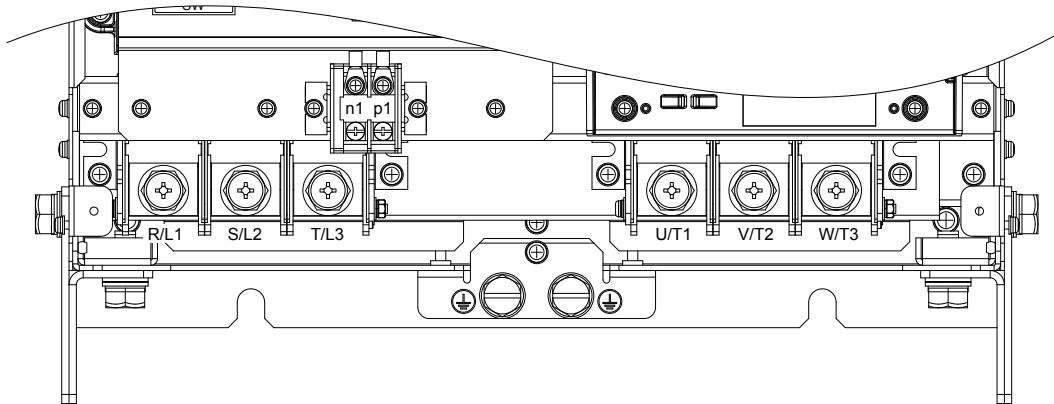

Figure 3.8 Main Circuit Terminal Configuration (Drive Models 2□0154, 2□0192, 4□0156, and 4□0180)

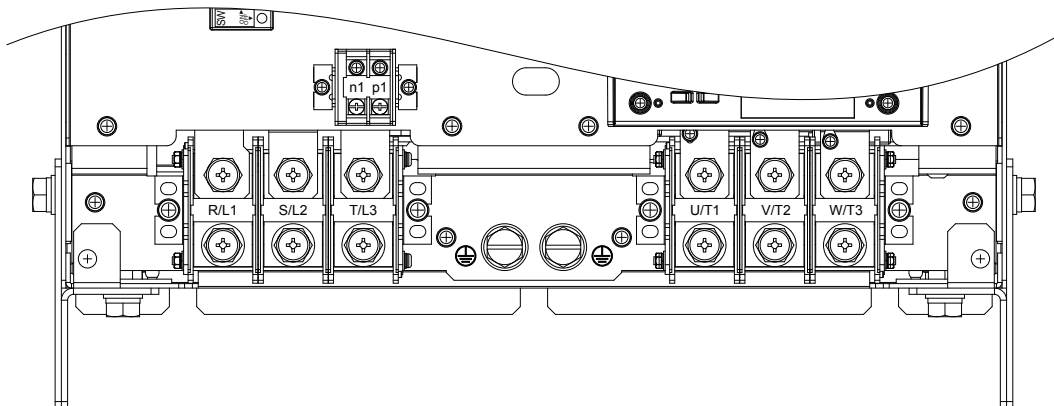

Figure 3.9 Main Circuit Terminal Configuration (Drive Models 2□0248, 4□0216, and 4□0240)

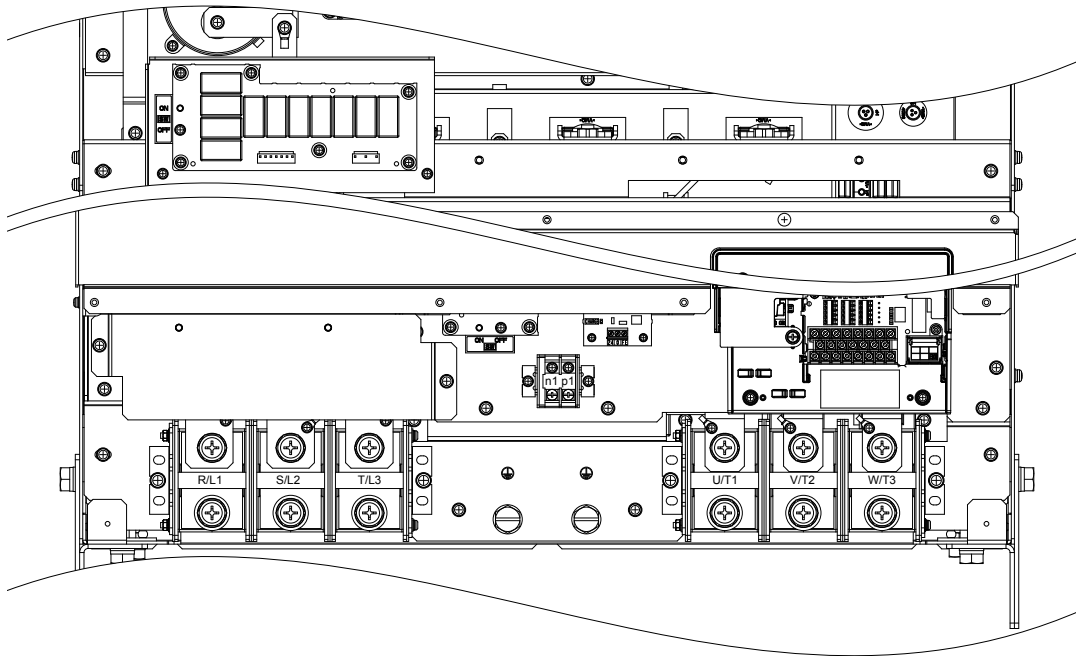

Figure 3.10 Main Circuit Terminal Configuration (Drive Models 4□0302 to 4□0414)

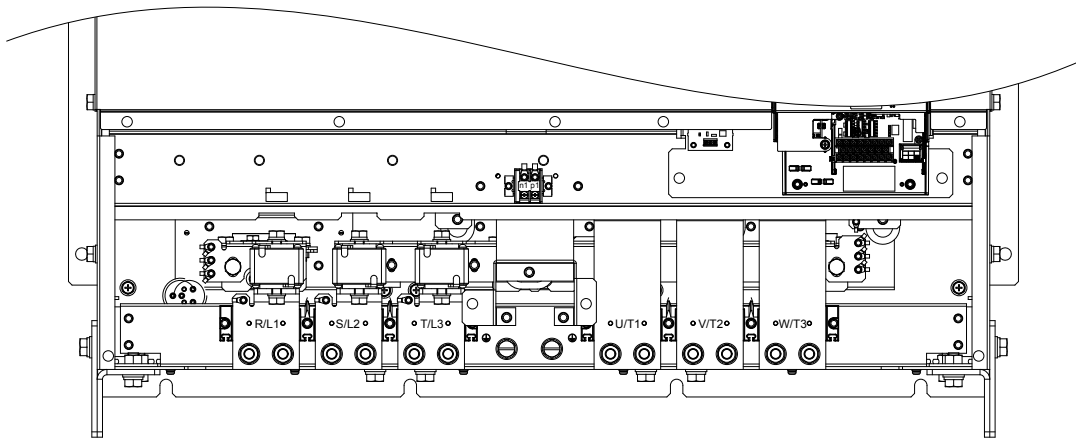

Figure 3.11 Main Circuit Terminal Configuration (Drive Models 4□0477 and 4□0590)

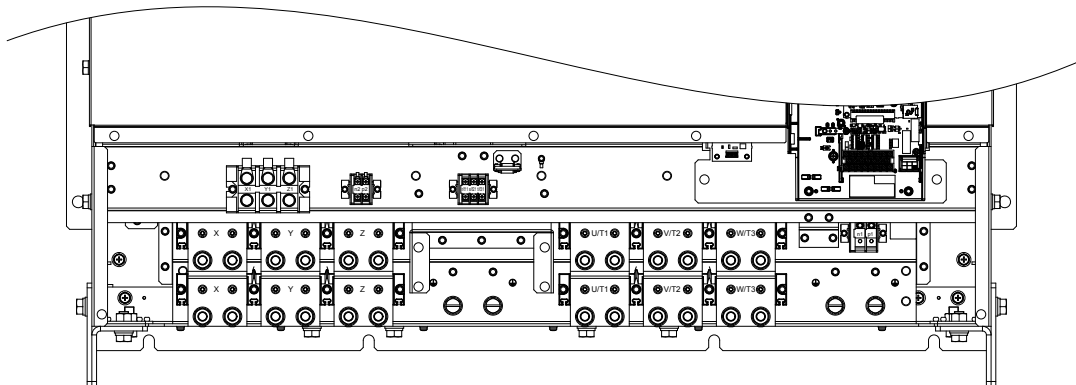

Figure 3.12 Main Circuit Terminal Configuration (Drive Models 4□0720 and 4□0930)

◆ Harmonic Filter Module

Figure 3.13 shows the main circuit terminal arrangements for the harmonic filter module.

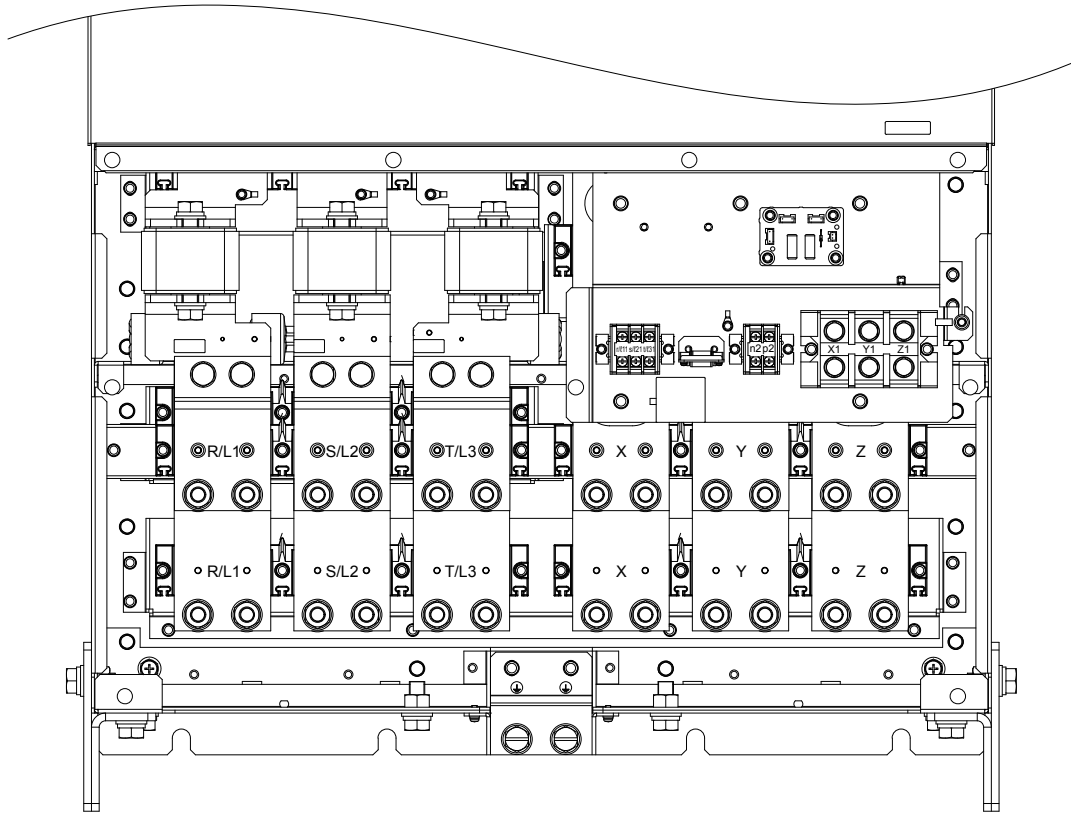

Figure 3.13 Main Circuit Terminal Configuration (Model EUJ7118□□.□)

3.5 Terminal Cover

Follow the procedure below to remove the terminal cover for wiring and to reattach the terminal cover after wiring is complete.

◆ Models 2□0028 to 2□0130 and 4□0011 to 4□0124

■ Removing the Terminal Cover

1. Loosen the terminal cover screw.

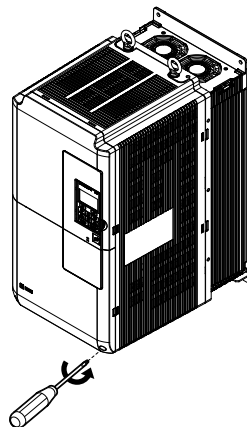

Figure 3.14 Removing the Terminal Cover

2. Push in on the tab located on the bottom of the terminal cover and gently pull forward to remove the terminal cover.

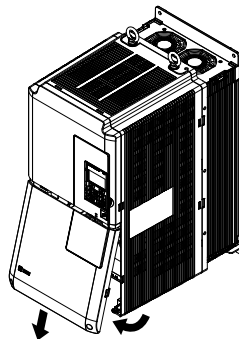

Figure 3.15 Removing the Terminal Cover

■ Reattaching the Terminal Cover

Power lines and signal wiring should pass through the opening provided. *Refer to Wiring the Main Circuit Terminal on page 93 and Wiring the Control Circuit Terminal on page 97 for details on wiring.*

Reattach the terminal cover after completing the wiring to the drive and other devices.

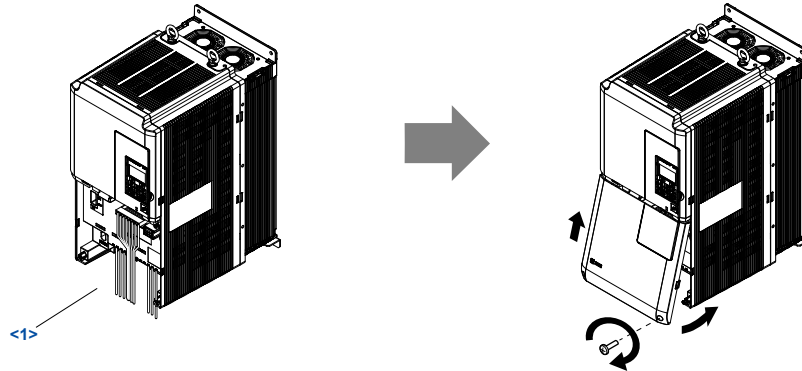

Figure 3.16 Reattaching the Terminal Cover

<1> Connect the ground wiring first, then the main circuit wiring, and finally the control circuit wiring.

◆ Models 2□0154 to 2□0248 and 4□0156 to 4□0930

■ Removing the Terminal Cover

1. Loosen the screws on the terminal cover, then pull down on the cover.

CAUTION! Do not completely remove the cover screws, just loosen them. If the cover screws are removed completely, the terminal cover may fall off causing an injury.

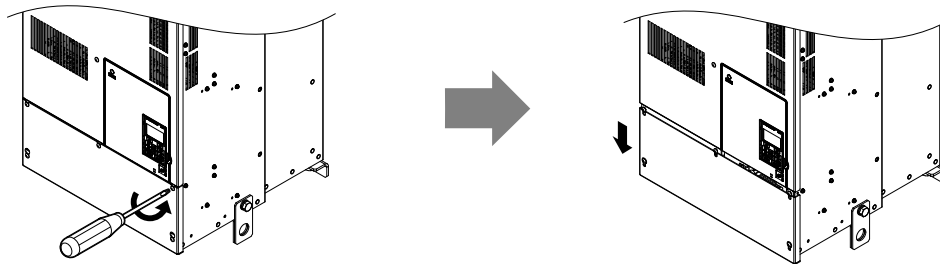

Figure 3.17 Removing the Terminal Cover

2. Pull forward on the terminal cover to free it from the drive.

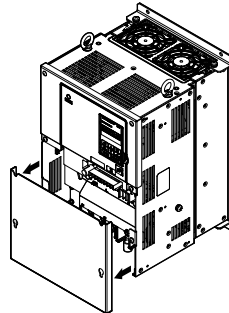

Figure 3.18 Removing the Terminal Cover

■ Reattaching the Terminal Cover

After wiring the terminal board and other devices, double-check connections and reattach the terminal cover. *Refer to Wiring the Main Circuit Terminal on page 93* and *Wiring the Control Circuit Terminal on page 97* for details on wiring.

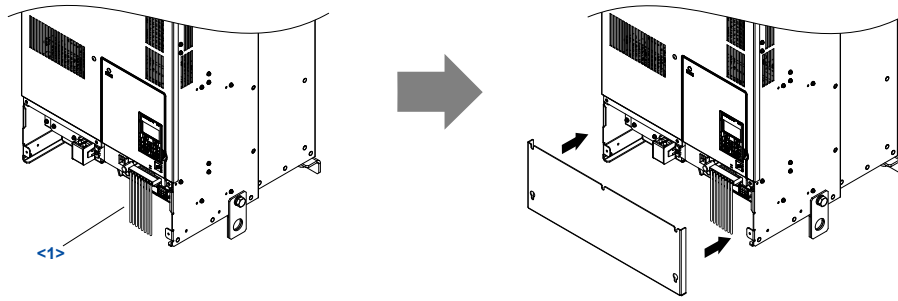

Figure 3.19 Reattaching the Terminal Cover

<1> Connect the ground wiring first, then the main circuit wiring, and finally the control circuit wiring.

3.6 HOA Keypad and Front Cover

Detach the HOA keypad from the drive for remote operation or when opening the front cover to install an option card.

NOTICE: Be sure to remove the HOA keypad prior to opening or reattaching the front cover. Leaving the HOA keypad plugged into the drive when removing the front cover can result in erroneous operation caused by a poor connection. Firmly fasten the front cover back into place before reattaching the HOA keypad.

◆ Removing/Reattaching the HOA Keypad

■ Removing the HOA Keypad

While pressing on the tab located on the right side of the digital operator, pull the HOA keypad forward to remove it from the drive.

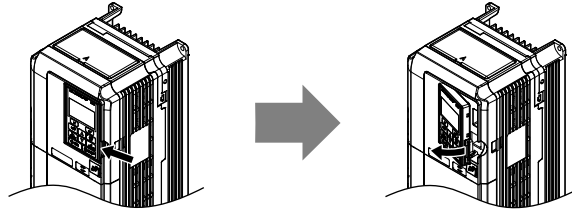

Figure 3.20 Removing the HOA Keypad

■ Reattaching the HOA Keypad

Insert the HOA keypad into the opening in the top cover while aligning it with the notches on the left side of the opening. Next, press gently on the right side of the keypad until it clicks into place.

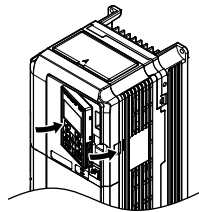

Figure 3.21 Reattaching the HOA Keypad

◆ Removing/Reattaching the Front Cover

■ Removing the Front Cover

Drive Models 2□0028 to 2□0130 and 4□0011 to 4□0124

After removing the terminal cover and the digital operator, loosen the screw that affixes the front cover. Pinch in on the tabs found on each side of the front cover, then pull forward to remove it from the drive.

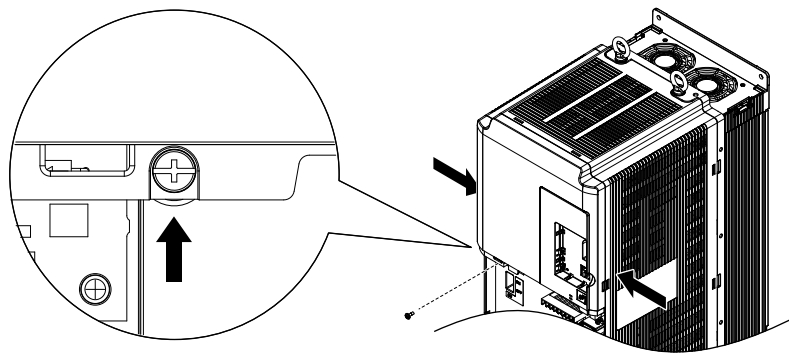

Figure 3.22 Remove the Front Cover (Drive Models 2□0028 to 2□0130 and 4□0011 to 4□0124)

Drive Models 2□0154 to 2□0248 and 4□0156 to 4□0930

1. Remove the terminal cover and the digital operator.
2. Loosen the installation screw on the front cover.
3. Use a straight-edge screwdriver to loosen the hooks on each side of the cover that hold it in place.

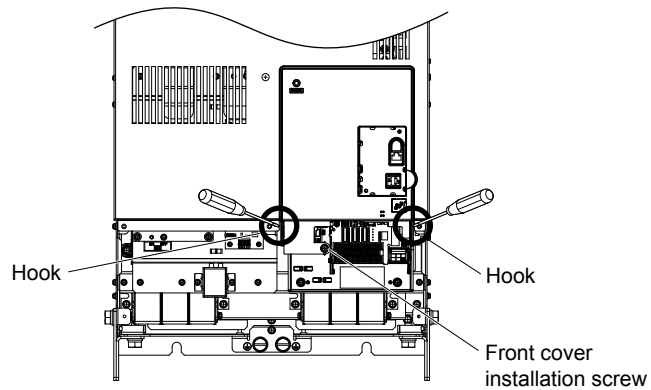

Figure 3.23 Remove the Front Cover (Drive Models 2□0154 to 2□0248 and 4□0156 to 4□0930)

4. Unhook the left side of the front cover then swing the left side towards you as shown in [Figure 3.24](#) until the cover comes off.

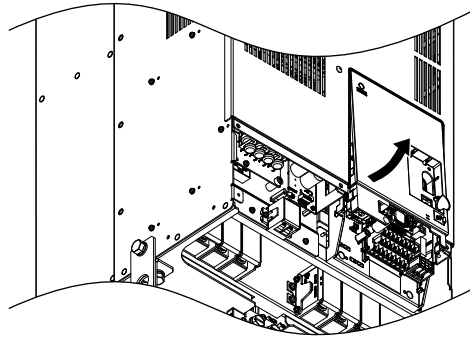

Figure 3.24 Remove the Front Cover (Drive Models 2□0154 to 2□0248 and 4□0156 to 4□0930)

■ Reattaching the Front Cover

Drive Models 2□0028 to 2□0130 and 4□0011 to 4□0124

Reverse the instructions given in *Remove the Front Cover (Drive Models 2□0028 to 2□0130 and 4□0011 to 4□0124)* on page 80 to reattach the front cover. Pinch inwards on the hooks found on each side of the front cover while guiding it back into the drive. Make sure it clicks firmly into place.

Drive Models 2□0154 to 2□0248 and 4□0156 to 4□0930

1. Slide the front cover so the hooks on the top connect to the drive.

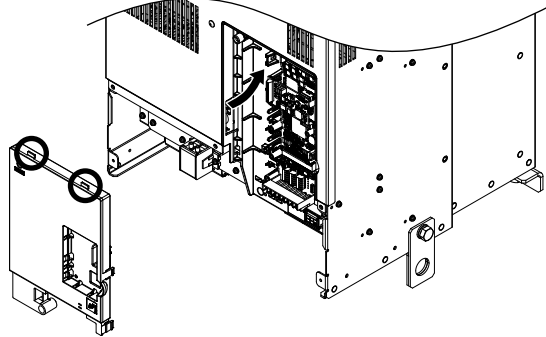

Figure 3.25 Reattach the Front Cover (Drive Models 2□0154 to 2□0248 and 4□0156 to 4□0930)

2. After connecting the hooks to the drive, press firmly on the cover to lock it into place.

3.7 Top Protective Cover

Drive models with IP00 specifications become IP20/NEMA 1, UL Type 1 after correctly installing a top protective cover and bottom conduit bracket. Do not attach the top protective cover when installing the drive in a control panel.

◆ Attaching the Top Protective Cover

Insert the small protruding hooks on the sides of the top protective cover into the provided mounting holes on the top of the drive. Pinch the hooks inward so that they connect with the mounting holes and fasten the top protective cover back into place.

Note: Attach a top protective cover and bottom cover from the optional End Cap Kit to an IP00/Open Type enclosure drive to convert the drive to an IP20/NEMA 1, UL Type 1 enclosure drive.

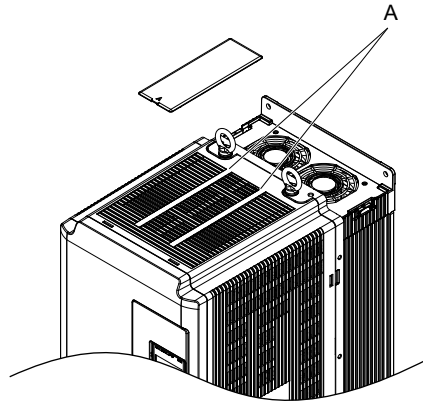

Figure 3.26 Reattaching the Protective Cover

◆ Removing the Top Protective Cover

Insert the tip of a straight-edge screwdriver into the small opening located on the front edge of the top protective cover. Gently apply pressure as shown in [Figure 3.27](#) to free the cover from the drive.

Note: Removing the top protective cover from an IP20/UL Type 1 enclosure drive voids UL Type 1 protection while retaining IP20 conformity.

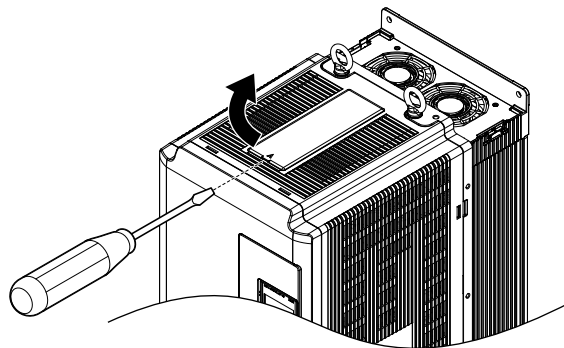

Figure 3.27 Removing the Top Protective Cover

3.8 Main Circuit Wiring

This section describes the functions, specifications, and procedures required to safely and properly wire the main circuit in the drive.

NOTICE: Do not solder the ends of wire connections to the drive. Soldered wiring connections can loosen over time. Improper wiring practices could result in drive malfunction due to loose terminal connections.

NOTICE: Do not switch the drive input to start or stop the motor. Frequently switching the drive on and off shortens the life of the DC bus charge circuit and the DC bus capacitors, and can cause premature drive failures. For the full performance life, refrain from switching the drive on and off more than once every 30 minutes.

◆ Main Circuit Terminal Functions

■ Drive Models 2□0028 to 2□0248 and 4□0011 to 4□0590

Table 3.2 Main Circuit Terminal Functions

Voltage Class	Three-Phase 200 V Class	Three-Phase 400 V Class	Function	Page
Drive Model	2□0028 to 2□0248	4□0011 to 4□0590		
Terminal	Type			
R/L1, S/L2, T/L3	Main circuit power supply input		Connects line power to the drive	67
U/T1, V/T2, W/T3	Drive output		Connects to the motor	
p1, n1	Momentary power loss recovery unit input		DC voltage terminals that connect to a momentary power loss recovery unit	
⊕	100 Ω or less	10 Ω or less	Grounding terminal	92

■ Drive Models 4□0720 to 4□0930

Table 3.3 Main Circuit Terminal Functions

Voltage Class	Three-Phase 400 V Class	Function	Page
Drive Model	4□0720 to 4□0930		
Terminal	Type		
X, Y, Z	Main circuit power supply input 1	Power supply input terminals that connect to the harmonic filter module.	69
X1, Y1, Z1	Main circuit power supply input 2		
r1/ℓ11, Ⓛ1/ℓ21, t1/ℓ31	Power supply voltage detection input	Connects to the harmonic filter module to detects the power supply voltage order and voltage levels.	
U/T1, V/T2, W/T3	Drive output	Connects to the motor	
p1, n1	Momentary power loss recovery unit input	DC voltage terminals that connect to a momentary power loss recovery unit	
p2, n2	DC voltage output	DC voltage terminals that connect to the harmonic filter module	
⊕	100 Ω or less	Grounding terminal	92

■ Harmonic Filter Module

Table 3.4 Harmonic Filter Module Main Circuit Terminal Functions

Terminal	Type	Function	Page
R/L1, S/L2, T/L3	Main circuit power supply input	Connects line power to the harmonic filter module	69
r1/ℓ11, Ⓛ1/ℓ21, t1/ℓ31	Power supply voltage detection input	Connects to drive models 4□0720 to 4□0930 to detect the power supply voltage order and voltage levels	
X, Y, Z	Filter module output 1	Harmonic filter module output terminals that connect to drive models 4□0720 to 4□0930.	
X1, Y1, Z1	Filter module output 2		
p2, n2	DC voltage output	DC voltage terminals that connect to the drive models 4□0720 to 4□0930	
⊕	100 Ω or less	Grounding terminal	92

◆ Protecting Main Circuit Terminals

■ Insulation Caps or Sleeves

Use insulation caps or sleeves when wiring the drive with crimp terminals. Take particular care to ensure that the wiring does not touch nearby terminals or the surrounding case.

■ Insulation Barrier

Insulation barriers are packaged with drive models 4□0477 and 4□0930 to provide added protection between terminals. Yaskawa recommends using the provided insulation barriers to ensure proper wiring. Refer to [Figure 3.28](#) for instructions on placement of the insulation barriers.

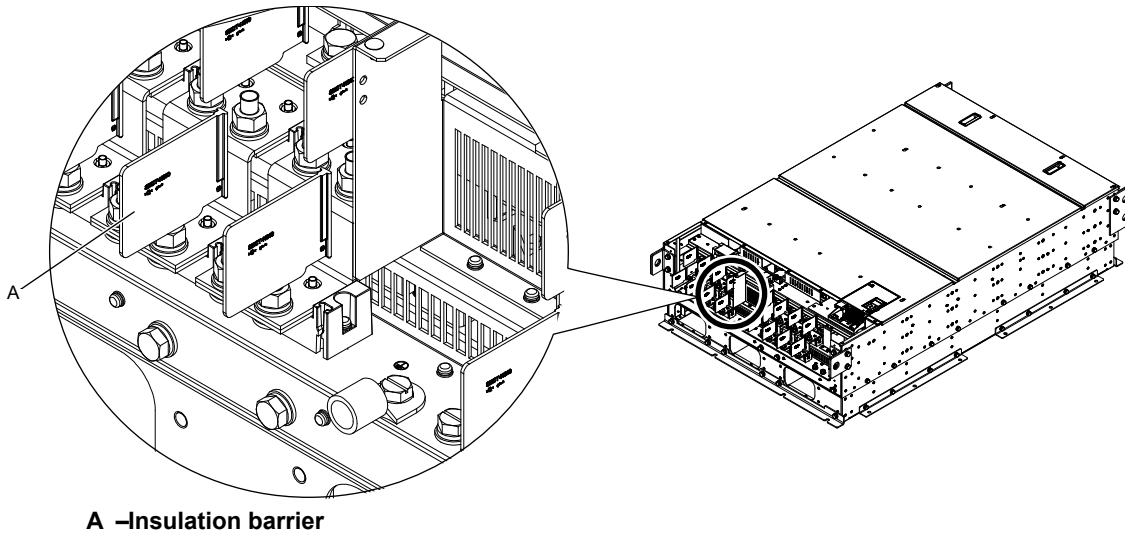

Figure 3.28 Installing Insulation Barriers

■ Main Circuit Protective Cover

Close the protective cover after wiring the main circuit terminals on drive models 2□0028 to 2□0081 and 4□0011 to 4□0077.

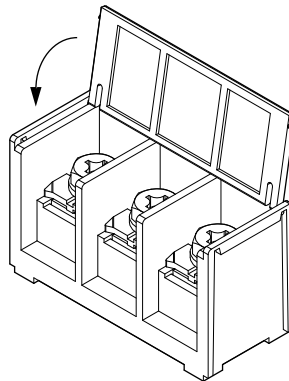
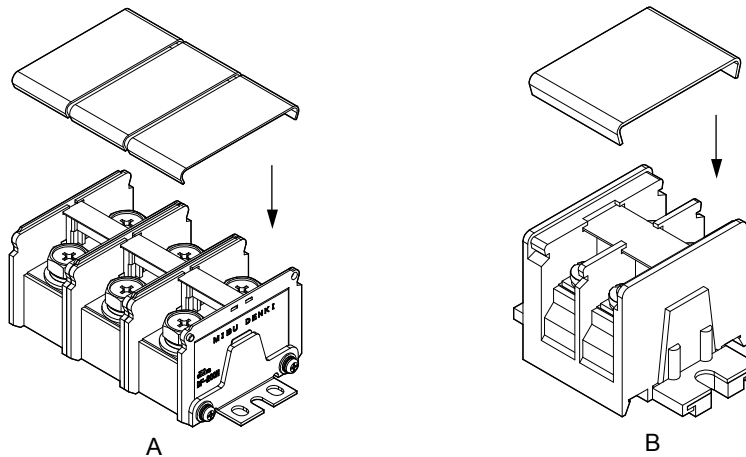

Figure 3.29 Main Circuit Protective Cover (Drive Models 2□0028 to 2□0081 and 4□0011 to 4□0077)

Attach the protective covers after wiring the main circuit terminals and p1, and n1 terminals on drive models 2□0104 to 2□0248 and 4□0096 to 4□0590.

Attach the protective covers after wiring the main circuit terminals and the p1, n1, p2, n2, r1, α 1, and t1 terminals on drive models 4□0720 to 4□0930.

3.8 Main Circuit Wiring



A – Main circuit terminal

B – Terminals p1 and n1

Figure 3.30 Protective Cover Example (Drive Model 2□0104)

◆ Main Circuit Wire Gauges and Tightening Torque

Use the tables in this section to select the appropriate wires and crimp terminals.

Gauges listed in the tables are for use in the United States.

- Note:** The recommended wires for the main circuit are 600 V, Class 2 vinyl-insulated copper wires with a continuous maximum operating temperature of 75 °C (167 °F). Assume these conditions:
- Ambient temperature: 40 °C (104 °F) maximum
 - Wiring distance: 100 m (328 ft) maximum
 - Normal Duty rated current value

Consider the amount of voltage drop when selecting wire gauges. Increase the wire gauge when the voltage drop is greater than 2% of motor rated voltage. Ensure the wire gauge is suitable for the terminal block. Use the following formula to calculate the amount of voltage drop:

$$\text{Line drop voltage (V)} = \sqrt{3} \times \text{wire resistance } (\Omega/\text{km}) \times \text{wire length (m)} \times \text{current (A)} \times 10^{-3}$$

[Refer to UL Standards Compliance on page 456](#) for information on UL compliance.

The wire gauges listed in the following tables are Yaskawa recommendations. Refer to local codes for proper wire gauge selections.

■ Three-Phase 200 V Class Drives

Table 3.5 Drive Wire Gauge and Torque Specifications (Three-Phase 200 V Class)

Drive Model	Terminal	For USA and Canada		For South America		Screw Size	Tightening Torque N·m (lb.in.)
		Recomm. Gauge mm ² (AWG, kcmil)	Applicable Gauge mm ² (AWG, kcmil)	Recomm. Gauge mm ² (AWG, kcmil)	Applicable Gauge mm ² (AWG, kcmil)		
2□0028	R/L1, S/L2, T/L3	10 (8)	6 to 10 (10 to 8)	4 (12)	2.5 to 10 (14 to 8)	M5	2.3 to 2.7 (20.4 to 23.9)
	U/T1, V/T2, W/T3	10 (8)	6 to 10 (10 to 8)	4 (12)	2.5 to 10 (14 to 8)	M5	
	⊕	10 (8)	6 to 16 (10 to 6)	6 (10)	6 to 16 (10 to 5)	M6	3.9 to 4.9 (34.7 to 43.4)
	p1, n1	2.5 (14)	2.5 to 4 (14 to 12)	2.5 (14)	2.5 to 4 (14 to 12)	M4	1 to 1.4 (8.9 to 12.4)
2□0042	R/L1, S/L2, T/L3	16 (6)	10 to 25 (8 to 3)	10 (8)	6 to 25 (10 to 3)	M6	4 to 6 (35.4 to 53.1)
	U/T1, V/T2, W/T3	16 (6)	10 to 25 (8 to 3)	10 (8)	6 to 25 (10 to 3)	M6	
	⊕	10 (8)	6 to 25 (10 to 3)	10 (8)	6 to 25 (10 to 3)	M8	8.8 to 10.8 (78.1 to 95.5)
	p1, n1	2.5 (14)	2.5 to 4 (14 to 12)	2.5 (14)	2.5 to 4 (14 to 12)	M4	1 to 1.4 (8.9 to 12.4)

Drive Model	Terminal	For USA and Canada		For South America		Screw Size	Tightening Torque N·m (lb.in.)
		Recomm. Gauge mm ² (AWG, kcmil)	Applicable Gauge mm ² (AWG, kcmil)	Recomm. Gauge mm ² (AWG, kcmil)	Applicable Gauge mm ² (AWG, kcmil)		
2□0054	R/L1, S/L2, T/L3	25 (4)	16 to 25 (6 to 3)	16 (5)	10 to 25 (8 to 3)	M6	4 to 6 (35.4 to 53.1)
	U/T1, V/T2, W/T3	25 (4)	16 to 25 (6 to 3)	16 (5)	10 to 25 (8 to 3)	M6	
	⊕	16 (6)	10 to 25 (8 to 3)	10 (8)	10 to 25 (8 to 3)	M8	8.8 to 10.8 (78.1 to 95.5)
	p1, n1	2.5 (14)	2.5 to 4 (14 to 12)	2.5 (14)	2.5 to 4 (14 to 12)	M4	1 to 1.4 (8.9 to 12.4)
2□0068	R/L1, S/L2, T/L3	25 (4)	25 (4 to 3)	16 (5)	16 to 25 (5 to 3)	M6	4 to 6 (35.4 to 53.1)
	U/T1, V/T2, W/T3	25 (4)	25 (4 to 3)	16 (5)	16 to 25 (5 to 3)	M6	
	⊕	16 (6)	16 to 25 (6 to 3)	16 (5)	16 to 25 (5 to 3)	M8	8.8 to 10.8 (78.1 to 95.5)
	p1, n1	2.5 (14)	2.5 to 4 (14 to 12)	2.5 (14)	2.5 to 4 (14 to 12)	M4	1 to 1.4 (8.9 to 12.4)
2□0081	R/L1, S/L2, T/L3	16 × 2 (6 × 2P)	16 to 25 × 2 (6 to 3 × 2P)	25 (3)	16 to 25 (5 to 3 × 2P)	M6	4 to 6 (35.4 to 53.1)
	U/T1, V/T2, W/T3	16 × 2 (6 × 2P)	16 to 25 × 2 (6 to 3 × 2P)	25 (3)	16 to 25 (5 to 3 × 2P)	M6	
	⊕	16 (6)	16 to 25 (6 to 3)	16 (5)	16 to 25 (5 to 3)	M8	8.8 to 10.8 (78.1 to 95.5)
	p1, n1	2.5 (14)	2.5 to 4 (14 to 12)	2.5 (14)	2.5 to 4 (14 to 12)	M4	1 to 1.4 (8.9 to 12.4)
2□0104	R/L1, S/L2, T/L3	35 (1)	16 to 50 × 2 (6 to 1/0 × 2P)	35 (1)	10 to 50 × 2P (8 to 1/0 × 2P)	M8	8 to 10 (70.8 to 88.5)
	U/T1, V/T2, W/T3	35 (1)	16 to 50 × 2 (6 to 1/0 × 2P)	35 (1)	10 to 50 × 2P (8 to 1/0 × 2P)	M8	
	⊕	25 (4)	25 to 35 (4 to 1)	25 (3)	10 to 35 (8 to 1)	M8	8.8 to 10.8 (78.1 to 95.5)
	p1, n1	2.5 (14)	2.5 to 4 (14 to 12)	2.5 (14)	2.5 to 4 (14 to 12)	M4	1.2 to 2.0 (10.4 to 17.4)
2□0130	R/L1, S/L2, T/L3	25 × 2 (4 × 2P)	16 to 50 × 2 (6 to 1/0 × 2P)	16 × 2P (5 × 2P)	10 to 50 × 2P (8 to 1/0 × 2P)	M8	8 to 10 (70.8 to 88.5)
	U/T1, V/T2, W/T3	25 × 2 (4 × 2P)	16 to 50 × 2 (6 to 1/0 × 2P)	16 × 2P (5 × 2P)	10 to 50 × 2P (8 to 1/0 × 2P)	M8	
	⊕	25 (4)	25 to 35 (4 to 1)	16 (5)	16 to 35 (5 to 1)	M8	8.8 to 10.8 (78.1 to 95.5)
	p1, n1	2.5 (14)	2.5 to 4 (14 to 12)	2.5 (14)	2.5 to 4 (14 to 12)	M4	1.2 to 2.0 (10.4 to 17.4)
2□0154	R/L1, S/L2, T/L3	25 × 2 (3 × 2P)	25 to 95 × 2 (4 to 4/0 × 2P)	25 × 2P (3 × 2P)	16 to 95 × 2P (5 to 4/0 × 2P)	M10	15 to 20 (130 to 173)
	U/T1, V/T2, W/T3	25 × 2 (3 × 2P)	25 to 95 × 2 (4 to 4/0 × 2P)	25 × 2P (3 × 2P)	16 to 95 × 2P (5 to 4/0 × 2P)	M10	
	⊕	25 (4)	25 to 70 (4 to 2/0)	25 (3)	25 to 70 (3 to 2/0)	M10	17.7 to 22.6 (156 to 200)
	p1, n1	2.5 (14)	2.5 to 4 (14 to 12)	2.5 (14)	2.5 to 4 (14 to 12)	M4	1.2 to 2.0 (10.4 to 17.4)
2□0192	R/L1, S/L2, T/L3	35 × 2 (1 × 2P)	25 to 95 × 2 (3 to 4/0 × 2P)	35 × 2P (1 × 2P)	25 to 95 × 2P (3 to 4/0 × 2P)	M10	15 to 20 (130 to 173)
	U/T1, V/T2, W/T3	35 × 2 (1 × 2P)	25 to 95 × 2 (3 to 4/0 × 2P)	35 × 2P (1 × 2P)	25 to 95 × 2P (3 to 4/0 × 2P)	M10	
	⊕	25 (3)	25 to 70 (4 to 2/0)	25 (3)	25 to 70 (3 to 2/0)	M10	17.7 to 22.6 (156 to 200)
	p1, n1	2.5 (14)	2.5 to 4 (14 to 12)	2.5 (14)	2.5 to 4 (14 to 12)	M4	1.2 to 2.0 (10.4 to 17.4)

3.8 Main Circuit Wiring

Drive Model	Terminal	For USA and Canada		For South America		Screw Size	Tightening Torque N·m (lb.in.)
		Recomm. Gauge mm ² (AWG, kcmil)	Applicable Gauge mm ² (AWG, kcmil)	Recomm. Gauge mm ² (AWG, kcmil)	Applicable Gauge mm ² (AWG, kcmil)		
2□0248	R/L1, S/L2, T/L3	70 × 2 (2/0 × 2P)	35 to 95 × 2 (1 to 4/0 × 2P)	50 × 2P (1/0 × 2P)	35 to 95 × 2P (1 to 4/0 × 2P)	M10	15 to 20 (130 to 173)
	U/T1, V/T2, W/T3	70 × 2 (2/0 × 2P)	35 to 95 × 2 (1 to 4/0 × 2P)	50 × 2P (1/0 × 2P)	35 to 95 × 2P (1 to 4/0 × 2P)	M10	
	⊕	25 (3)	25 to 95 (4 to 4/0)	35 (1)	25 to 95 (3 to 4/0)	M12	31.4 to 39.2 (278 to 347)
	p1, n1	2.5 (14)	2.5 to 4 (14 to 12)	2.5 (14)	2.5 to 4 (14 to 12)	M4	1.2 to 2.0 (10.4 to 17.4)

■ Three-Phase 400 V Class Drives

Table 3.6 Drive Wire Gauge and Torque Specifications (Three-Phase 400 V Class)

Drive Model	Terminal	For USA and Canada		For South America		Screw Size	Tightening Torque N·m (lb.in.)
		Recomm. Gauge mm ² (AWG, kcmil)	Wire Range mm ² (AWG, kcmil)	Recomm. Gauge mm ² (AWG, kcmil)	Wire Range mm ² (AWG, kcmil)		
4□0011	R/L1, S/L2, T/L3	2.5 (14)	2.5 to 10 (14 to 8)	2.5 (14)	2.5 to 10 (14 to 8)	M5	2.3 to 2.7 (20.4 to 23.9)
	U/T1, V/T2, W/T3	2.5 (14)	2.5 to 10 (14 to 8)	2.5 (14)	2.5 to 10 (14 to 8)	M5	
	⊕	6 (10)	4 to 16 (12 to 6)	2.5 (14)	2.5 to 16 (14 to 5)	M6	3.9 to 4.9 (34.7 to 43.4)
	p1, n1	2.5 (14)	2.5 to 4 (14 to 12)	2.5 (14)	2.5 to 4 (14 to 12)	M4	1 to 1.4 (8.9 to 12.4)
4□0014	R/L1, S/L2, T/L3	4 (12)	2.5 to 10 (14 to 8)	2.5 (14)	2.5 to 10 (14 to 8)	M5	2.3 to 2.7 (20.4 to 23.9)
	U/T1, V/T2, W/T3	4 (12)	2.5 to 10 (14 to 8)	2.5 (14)	2.5 to 10 (14 to 8)	M5	
	⊕	6 (10)	4 to 16 (12 to 6)	2.5 (14)	2.5 to 16 (14 to 5)	M6	3.9 to 4.9 (34.7 to 43.4)
	p1, n1	2.5 (14)	2.5 to 4 (14 to 12)	2.5 (14)	2.5 to 4 (14 to 12)	M4	1 to 1.4 (8.9 to 12.4)
4□0021	R/L1, S/L2, T/L3	6 (10)	4 to 10 (12 to 8)	2.5 (14)	2.5 to 10 (14 to 8)	M5	2.3 to 2.7 (20.4 to 23.9)
	U/T1, V/T2, W/T3	6 (10)	4 to 10 (12 to 8)	2.5 (14)	2.5 to 10 (14 to 8)	M5	
	⊕	6 (10)	4 to 16 (12 to 6)	2.5 (14)	2.5 to 16 (14 to 5)	M6	3.9 to 4.9 (34.7 to 43.4)
	p1, n1	2.5 (14)	2.5 to 4 (14 to 12)	2.5 (14)	2.5 to 4 (14 to 12)	M4	1 to 1.4 (8.9 to 12.4)
4□0027	R/L1, S/L2, T/L3	10 (8)	6 to 10 (10 to 8)	4 (12)	2.5 to 10 (14 to 8)	M5	2.3 to 2.7 (20.4 to 23.9)
	U/T1, V/T2, W/T3	10 (8)	6 to 10 (10 to 8)	4 (12)	2.5 to 10 (14 to 8)	M5	
	⊕	10 (8)	4 to 16 (12 to 6)	4 (12)	4 to 16 (12 to 5)	M6	3.9 to 4.9 (34.7 to 43.4)
	p1, n1	2.5 (14)	2.5 to 4 (14 to 12)	2.5 (14)	2.5 to 4 (14 to 12)	M4	1 to 1.4 (8.9 to 12.4)
4□0034	R/L1, S/L2, T/L3	10 (8)	10 (8)	6 (10)	4 to 10 (12 to 8)	M5	2.3 to 2.7 (20.4 to 23.9)
	U/T1, V/T2, W/T3	10 (8)	10 (8)	6 (10)	4 to 10 (12 to 8)	M5	
	⊕	10 (8)	6 to 16 (10 to 6)	6 (10)	6 to 16 (10 to 5)	M6	3.9 to 4.9 (34.7 to 43.4)
	p1, n1	2.5 (14)	2.5 to 4 (14 to 12)	2.5 (14)	2.5 to 4 (14 to 12)	M4	1 to 1.4 (8.9 to 12.4)

Drive Model	Terminal	For USA and Canada		For South America		Screw Size	Tightening Torque N·m (lb.in.)
		Recomm. Gauge mm ² (AWG, kcmil)	Wire Range mm ² (AWG, kcmil)	Recomm. Gauge mm ² (AWG, kcmil)	Wire Range mm ² (AWG, kcmil)		
4□0040	R/L1, S/L2, T/L3	10 (8)	10 to 25 (8 to 3)	10 (8)	6 to 25 (10 to 3)	M6	4 to 6 (35.4 to 53.1)
	U/T1, V/T2, W/T3	10 (8)	10 to 25 (8 to 3)	10 (8)	6 to 25 (10 to 3)	M6	
	⊕	10 (8)	10 to 25 (10 to 3)	10 (8)	6 to 25 (10 to 3)	M8	8.8 to 10.8 (78.1 to 95.5)
	p1, n1	2.5 (14)	2.5 to 4 (14 to 12)	2.5 (14)	2.5 to 4 (14 to 12)	M4	1 to 1.4 (8.9 to 12.4)
4□0052	R/L1, S/L2, T/L3	16 (6)	10 to 25 (8 to 3)	10 (8)	10 to 25 (8 to 3)	M6	4 to 6 (35.4 to 53.1)
	U/T1, V/T2, W/T3	16 (6)	10 to 25 (8 to 3)	10 (8)	10 to 25 (8 to 3)	M6	
	⊕	16 (6)	10 to 25 (8 to 3)	10 (8)	10 to 25 (8 to 3)	M8	8.8 to 10.8 (78.1 to 95.5)
	p1, n1	2.5 (14)	2.5 to 4 (14 to 12)	2.5 (14)	2.5 to 4 (14 to 12)	M4	1 to 1.4 (8.9 to 12.4)
4□0065	R/L1, S/L2, T/L3	25 (4)	16 to 25 (6 to 3)	16 (5)	10 to 25 (8 to 3)	M6	4 to 6 (35.4 to 53.1)
	U/T1, V/T2, W/T3	25 (4)	16 to 25 (6 to 3)	16 (5)	10 to 25 (8 to 3)	M6	
	⊕	16 (6)	16 to 25 (6 to 3)	16 (5)	16 to 25 (5 to 3)	M8	8.8 to 10.8 (78.1 to 95.5)
	p1, n1	2.5 (14)	2.5 to 4 (14 to 12)	2.5 (14)	2.5 to 4 (14 to 12)	M4	1 to 1.4 (8.9 to 12.4)
4□0077	R/L1, S/L2, T/L3	25 (3)	25 (4 to 3)	25 (3)	16 to 25 (5 to 3)	M6	4 to 6 (35.4 to 53.1)
	U/T1, V/T2, W/T3	25 (3)	25 (4 to 3)	25 (3)	16 to 25 (5 to 3)	M6	
	⊕	16 (6)	16 to 25 (6 to 3)	16 (5)	16 to 25 (5 to 3)	M8	8.8 to 10.8 (78.1 to 95.5)
	p1, n1	2.5 (14)	2.5 to 4 (14 to 12)	2.5 (14)	2.5 to 4 (14 to 12)	M4	1 to 1.4 (8.9 to 12.4)
4□0096	R/L1, S/L2, T/L3	35 (1)	10 to 50 (8 to 1/0 × 2P)	35 (1)	10 to 50 × 2P (8 to 1/0 × 2P)	M8	8 to 10 (70.8 to 88.5)
	U/T1, V/T2, W/T3	35 (1)	10 to 50 (8 to 1/0 × 2P)	35 (1)	10 to 50 × 2P (8 to 1/0 × 2P)	M8	
	⊕	25 (4)	25 to 35 (4 to 1)	25 (3)	10 to 35 (8 to 1)	M8	8.8 to 10.8 (78.1 to 95.5)
	p1, n1	2.5 (14)	2.5 to 4 (14 to 12)	2.5 (14)	2.5 to 4 (14 to 12)	M4	1.2 to 2.0 (10.4 to 17.4)
4□0124	R/L1, S/L2, T/L3	25 × 2 (4 × 2P)	16 to 50 × 2 (6 to 1/0 × 2P)	16 × 2P (5 × 2P)	10 to 50 × 2P (8 to 1/0 × 2P)	M8	8 to 10 (70.8 to 88.5)
	U/T1, V/T2, W/T3	25 × 2 (4 × 2P)	16 to 50 × 2 (6 to 1/0 × 2P)	16 × 2P (5 × 2P)	10 to 50 × 2P (8 to 1/0 × 2P)	M8	
	⊕	25 (4)	25 to 35 (4 to 1)	16 (5)	16 to 35 (5 to 1)	M8	8.8 to 10.8 (78.1 to 95.5)
	p1, n1	2.5 (14)	2.5 to 4 (14 to 12)	2.5 (14)	2.5 to 4 (14 to 12)	M4	1.2 to 2.0 (10.4 to 17.4)
4□0156	R/L1, S/L2, T/L3	25 × 2 (3 × 2P)	25 to 95 × 2 (4 to 4/0 × 2P)	25 × 2P (3 × 2P)	16 to 95 × 2P (5 to 4/0 × 2P)	M10	15 to 20 (130 to 173)
	U/T1, V/T2, W/T3	25 × 2 (3 × 2P)	25 to 95 × 2 (4 to 4/0 × 2P)	25 × 2P (3 × 2P)	16 to 95 × 2P (5 to 4/0 × 2P)	M10	
	⊕	25 (4)	25 to 70 (4 to 2/0)	25 (3)	25 to 70 (3 to 2/0)	M10	17.7 to 22.6 (156 to 200)
	p1, n1	2.5 (14)	2.5 to 4 (14 to 12)	2.5 (14)	2.5 to 4 (14 to 12)	M4	1.2 to 2.0 (10.4 to 17.4)

3.8 Main Circuit Wiring

Drive Model	Terminal	For USA and Canada		For South America		Screw Size	Tightening Torque N·m (lb.in.)
		Recomm. Gauge mm ² (AWG, kcmil)	Wire Range mm ² (AWG, kcmil)	Recomm. Gauge mm ² (AWG, kcmil)	Wire Range mm ² (AWG, kcmil)		
4□0180	R/L1, S/L2, T/L3	35 × 2 (2 × 2P)	25 to 95 × 2 (3 to 4/0 × 2P)	25 × 2P (3 × 2P)	25 to 95 × 2P (3 to 4/0 × 2P)	M10	15 to 20 (130 to 173)
	U/T1, V/T2, W/T3	35 × 2 (2 × 2P)	25 to 95 × 2 (3 to 4/0 × 2P)	25 × 2P (3 × 2P)	25 to 95 × 2P (3 to 4/0 × 2P)	M10	
	⊕	25 (3)	25 to 70 (4 to 2/0)	25 (3)	25 to 70 (3 to 2/0)	M10	17.7 to 22.6 (156 to 200)
	p1, n1	2.5 (14)	2.5 to 4 (14 to 12)	2.5 (14)	2.5 to 4 (14 to 12)	M4	1.2 to 2.0 (10.4 to 17.4)
4□0216	R/L1, S/L2, T/L3	50 × 2 (1/0 × 2P)	35 to 95 × 2 (2 to 4/0 × 2P)	35 × 2P (1 × 2P)	25 to 95 × 2P (3 to 4/0 × 2P)	M10	15 to 20 (130 to 173)
	U/T1, V/T2, W/T3	50 × 2 (1/0 × 2P)	35 to 95 × 2 (2 to 4/0 × 2P)	35 × 2P (1 × 2P)	25 to 95 × 2P (3 to 4/0 × 2P)	M10	
	⊕	25 (3)	25 to 95 (4 to 4/0)	35 (1)	25 to 95 (3 to 4/0)	M12	31.4 to 39.2 (278 to 347)
	p1, n1	2.5 (14)	2.5 to 4 (14 to 12)	2.5 (14)	2.5 to 4 (14 to 12)	M4	1.2 to 2.0 (10.4 to 17.4)
4□0240	R/L1, S/L2, T/L3	50 × 2 (1/0 × 2P)	50 to 95 × 2 (1/0 to 4/0 × 2P)	50 × 2P (1/0 × 2P)	35 to 95 × 2P (1 to 4/0 × 2P)	M10	15 to 20 (130 to 173)
	U/T1, V/T2, W/T3	50 × 2 (1/0 × 2P)	50 to 95 × 2 (1/0 to 4/0 × 2P)	50 × 2P (1/0 × 2P)	35 to 95 × 2P (1 to 4/0 × 2P)	M10	
	⊕	35 (2)	35 to 95 (2 to 4/0)	50 (1/0)	35 to 95 (1 to 4/0)	M12	31.4 to 39.2 (278 to 347)
	p1, n1	2.5 (14)	2.5 to 4 (14 to 12)	2.5 (14)	2.5 to 4 (14 to 12)	M4	1.2 to 2.0 (10.4 to 17.4)
4□0302	R/L1, S/L2, T/L3	70 × 2 (3/0 × 2P)	50 to 95 × 2 (1/0 to 4/0 × 2P)	70 × 2P (3/0 × 2P)	50 to 95 × 2P (1/0 to 4/0 × 2P)	M10	15 to 20 (130 to 173)
	U/T1, V/T2, W/T3	70 × 2 (3/0 × 2P)	50 to 95 × 2 (1/0 to 4/0 × 2P)	70 × 2P (3/0 × 2P)	50 to 95 × 2P (1/0 to 4/0 × 2P)	M10	
	⊕	35 (1)	35 to 150 (1 to 300)	70 (3/0)	35 to 150 (1 to 300)	M12	31.4 to 39.2 (278 to 347)
	p1, n1	2.5 (14)	2.5 to 4 (14 to 12)	2.5 (14)	2.5 to 4 (14 to 12)	M4	1.2 to 2.0 (10.4 to 17.4)
4□0361	R/L1, S/L2, T/L3	95 × 2 (4/0 × 2P)	70 to 95 × 2 (3/0 to 4/0 × 2P)	95 × 2P (4/0 × 2P)	70 to 95 × 2P (3/0 to 4/0 × 2P)	M10	15 to 20 (130 to 173)
	U/T1, V/T2, W/T3	95 × 2 (4/0 × 2P)	70 to 95 × 2 (3/0 to 4/0 × 2P)	95 × 2P (4/0 × 2P)	70 to 95 × 2P (3/0 to 4/0 × 2P)	M10	
	⊕	50 (1/0)	50 to 150 (1/0 to 300)	95 (4/0)	70 to 150 (3/0 to 300)	M12	31.4 to 39.2 (278 to 347)
	p1, n1	2.5 (14)	2.5 to 4 (14 to 12)	2.5 (14)	2.5 to 4 (14 to 12)	M4	1.2 to 2.0 (10.4 to 17.4)
4□0414	R/L1, S/L2, T/L3	150 × 2 (300 × 2P)	95 to 150 × 2 (4/0 to 300 × 2P)	95 × 2P (4/0 × 2P)	95 to 150 × 2P (4/0 to 300 × 2P)	M12	25 to 35 (217 to 304)
	U/T1, V/T2, W/T3	150 × 2 (300 × 2P)	95 to 150 × 2 (4/0 to 300 × 2P)	95 × 2P (4/0 × 2P)	95 to 150 × 2P (4/0 to 300 × 2P)	M12	
	⊕	50 (1/0)	50 to 240 (1/0 to 400)	95 (4/0)	70 to 240 (3/0 to 400)	M12	31.4 to 39.2 (278 to 347)
	p1, n1	2.5 (14)	2.5 to 4 (14 to 12)	2.5 (14)	2.5 to 4 (14 to 12)	M4	1.2 to 2.0 (10.4 to 17.4)

Drive Model	Terminal	For USA and Canada		For South America		Screw Size	Tightening Torque N·m (lb.in.)
		Recomm. Gauge mm ² (AWG, kcmil)	Wire Range mm ² (AWG, kcmil)	Recomm. Gauge mm ² (AWG, kcmil)	Wire Range mm ² (AWG, kcmil)		
4□0477	R/L1, S/L2, T/L3	95 × 4P (3/0 × 4P)	150 × 2P 70 to 150 × 4P (300 × 2P 2/0 to 300 × 4P)	120 × 2P (250 × 2P)	95 to 150 × 2P (4/0 to 300 × 2P)	M12	31.4 to 39.2 (278 to 347)
	U/T1, V/T2, W/T3	95 × 4P (3/0 × 4P)	150 × 2P 70 to 150 × 4P (300 × 2P 2/0 to 300 × 4P)	120 × 2P (250 × 2P)	95 to 150 × 2P (4/0 to 300 × 2P)	M12	31.4 to 39.2 (278 to 347)
	⊕	50 (1/0)	50 to 150 (1/0 to 300)	120 (250)	95 to 150 (4/0 to 300)	M12	31.4 to 39.2 (278 to 347)
	p1, n1	2.5 (14)	2.5 to 4 (14 to 12)	2.5 (14)	2.5 to 4 (14 to 12)	M4	1.2 to 2.0 (10.4 to 17.4)
4□0590	R/L1, S/L2, T/L3	120 × 4P (250 × 4P)	95 to 150 × 4P (3/0 to 300 × 4P)	95 × 4P (4/0 × 4P)	120 to 150 × 2P 70 to 150 × 4P (250 to 300 × 2P 2/0 to 300 × 4P)	M12	31.4 to 39.2 (278 to 347)
	U/T1, V/T2, W/T3	120 × 4P (250 × 4P)	95 to 150 × 4P (3/0 to 300 × 4P)	95 × 4P (4/0 × 4P)	120 to 150 × 2P 70 to 150 × 4P (250 to 300 × 2P 2/0 to 300 × 4P)	M12	31.4 to 39.2 (278 to 347)
	⊕	70 (2/0)	70 to 150 (2/0 to 300)	95 × 2P (4/0 × 2P)	120 to 150 95 to 150 × 2P (250 to 300 4/0 to 300 × 2P)	M12	31.4 to 39.2 (278 to 347)
	p1, n1	2.5 (14)	2.5 to 4 (14 to 12)	2.5 (14)	2.5 to 4 (14 to 12)	M4	1.2 to 2.0 (10.4 to 17.4)
4□0720	X, Y, Z	150 × 4P (300 × 4P)	120 to 150 × 4P (250 to 300 × 4P)	120 × 4P (250 × 4P)	95 to 150 × 4P (4/0 to 300 × 4P)	M12	31.4 to 39.2 (278 to 347)
	X1, Y1, Z1	50 (1/0)	50 to 70 (1/0 to 2/0)	35 (1)	35 to 50 (1 to 1/0)	M8	5.4 to 6.0 (47.8 to 53.0)
	U/T1, V/T2, W/T3	150 × 4P (300 × 4P)	120 to 150 × 4P (250 to 300 × 4P)	120 × 4P (250 × 4P)	95 to 150 × 4P (4/0 to 300 × 4P)	M12	31.4 to 39.2 (278 to 347)
	⊕	95 (3/0)	95 to 150 (3/0 to 300)	120 × 2P (250 × 2P)	95 to 150 × 2P (4/0 to 300 × 2P)	M12	31.4 to 39.2 (278 to 347)
	r1, s1, t1	2.5 (14)	2.5 to 4 (14 to 12)	2.5 (14)	2.5 to 4 (14 to 12)	M4	1.2 to 2.0 (10.4 to 17.4)
	p1, n1	2.5 (14)	2.5 to 16 (14 to 6)	2.5 (14)	2.5 to 16 (14 to 6)	M5	2.0 to 2.5 (17.4 to 21.7)
	p2, n2	2.5 (14)	2.5 to 4 (14 to 12)	2.5 (14)	2.5 to 4 (14 to 12)	M4	1.2 to 2.0 (10.4 to 17.4)
4□0930	X, Y, Z	95 × 8P (4/0 × 8P)	95 to 150 × 8P (4/0 to 300 × 8P)	150 × 4P (300 × 4P)	150 × 4P (300 × 4P)	M12	31.4 to 39.2 (278 to 347)
	X1, Y1, Z1	50 (1/0)	50 to 70 (1/0 to 2/0)	35 (1)	35 to 50 (1 to 1/0)	M8	5.4 to 6.0 (47.8 to 53.0)
	U/T1, V/T2, W/T3	95 × 8P (4/0 × 8P)	95 to 150 × 8P (4/0 to 300 × 8P)	150 × 4P (300 × 4P)	150 × 4P (300 × 4P)	M12	31.4 to 39.2 (278 to 347)
	⊕	95 (4/0)	95 to 150 (4/0 to 300)	150 × 2P (300 × 2P)	150 × 2P (300 × 2P)	M12	31.4 to 39.2 (278 to 347)
	r1, s1, t1	2.5 (14)	2.5 to 4 (14 to 12)	2.5 (14)	2.5 to 4 (14 to 12)	M4	1.2 to 2.0 (10.4 to 17.4)
	p1, n1	2.5 (14)	2.5 to 16 (14 to 6)	2.5 (14)	2.5 to 16 (14 to 6)	M5	2.0 to 2.5 (17.4 to 21.7)
	p2, n2	2.5 (14)	2.5 to 4 (14 to 12)	2.5 (14)	2.5 to 4 (14 to 12)	M4	1.2 to 2.0 (10.4 to 17.4)

3.8 Main Circuit Wiring

■ Harmonic Filter Modules

Table 3.7 Harmonic Filter Module Wire Gauge and Torque Specifications for Models 4□0720 to 4□0930

Model	Terminal	For USA and Canada		For South America		Screw Size	Tightening Torque N·m (lb.in.)
		Recomm. Gauge mm ² (AWG, kcmil)	Wire Range mm ² (AWG, kcmil)	Recomm. Gauge mm ² (AWG, kcmil)	Wire Range mm ² (AWG, kcmil)		
EUJ71180□.□	R/L1, S/L2, T/L3	150 × 4P (300 × 4P)	120 to 150 × 4P (250 to 300 × 4P)	120 × 4P (250 × 4P)	95 to 150 × 4P (4/0 to 300 × 2P)	M12	31.4 to 39.2 (278 to 347)
	X, Y, Z	150 × 4P (300 × 4P)	120 to 150 × 4P (250 to 300 × 4P)	120 × 4P (250 × 4P)	95 to 150 × 4P (4/0 to 300 × 2P)	M12	31.4 to 39.2 (278 to 347)
	X1, Y1, Z1	50 (1/0)	50 to 70 (1/0 to 2/0)	35 (1)	35 to 50 (1 to 1/0)	M8	5.4 to 6.0 (47.8 to 53.0)
	⊕	95 (3/0)	95 to 150 (3/0 to 300)	120 × 2P (250 × 2P)	95 to 150 × 2P (4/0 to 300)	M12	31.4 to 39.2 (278 to 347)
	r1, s1, t1	2.5 (14)	2.5 to 4 (14 to 12)	2.5 (14)	2.5 to 4 (14 to 12)	M4	1.2 to 2.0 (10.4 to 17.4)
	p2, n2	2.5 (14)	2.5 to 4 (14 to 12)	2.5 (14)	2.5 to 4 (14 to 12)	M4	1.2 to 2.0 (10.4 to 17.4)
EUJ71182□.□	R/L1, S/L2, T/L3	95 × 8P (4/0 × 8P)	95 to 150 × 8P (4/0 to 300 × 8P)	150 × 4P (300 × 4P)	150 × 4P (300 × 4P)	M12	31.4 to 39.2 (278 to 347)
	X, Y, Z	95 × 8P (4/0 × 8P)	95 to 150 × 8P (4/0 to 300 × 8P)	150 × 4P (300 × 4P)	150 × 4P (300 × 4P)	M12	31.4 to 39.2 (278 to 347)
	X1, Y1, Z1	50 (1/0)	50 to 70 (1/0 to 2/0)	35 (1)	35 to 50 (1 to 1/0)	M8	5.4 to 6.0 (47.8 to 53.0)
	⊕	95 (4/0)	95 to 150 (4/0 to 300)	150 × 2P (300 × 2P)	150 × 2P (300 × 2P)	M12	31.4 to 39.2 (278 to 347)
	r1, s1, t1	2.5 (14)	2.5 to 4 (14 to 12)	2.5 (14)	2.5 to 4 (14 to 12)	M4	1.2 to 2.0 (10.4 to 17.4)
	p2, n2	2.5 (14)	2.5 to 4 (14 to 12)	2.5 (14)	2.5 to 4 (14 to 12)	M4	1.2 to 2.0 (10.4 to 17.4)

◆ Main Circuit Terminal and Motor Wiring

This section outlines the various steps, precautions, and checkpoints for wiring the main circuit terminals and motor terminals.

NOTICE: When connecting the motor to the drive output terminals U/T1, V/T2, and W/T3, the phase order for the drive and motor should match. Failure to comply with proper wiring practices may cause the motor to run in reverse if the phase order is backward.

NOTICE: Route motor leads U/T1, V/T2, and W/T3 separate from all other leads to reduce possible interference related issues. Failure to comply may result in abnormal operation of drive and nearby equipment.

■ Cable Length Between Drive and Motor

Voltage drop along the motor cable may cause reduced motor torque when the wiring between the drive and the motor is too long, especially at low frequency output. This can also be a problem when motors are connected in parallel with a fairly long motor cable. Drive output current will increase as the leakage current from the cable increases. An increase in leakage current may trigger an overcurrent situation and weaken the accuracy of the current detection.

Adjust the drive carrier frequency according to [Table 3.8](#). If the motor wiring distance exceeds 100 m because of the system configuration, reduce the ground currents.

Table 3.8 Cable Length Between Drive and Motor

Cable Length	50 m or less	Greater than 50 m
Carrier Frequency	10 kHz or less	4 kHz or less

Note: When setting carrier frequency for drives running multiple motors, calculate cable length as the total wiring distance to all connected motors.

■ Ground Wiring

Follow the precautions below when wiring the ground for one drive or a series of drives.

WARNING! Electrical Shock Hazard. Always use a ground wire that complies with technical standards on electrical equipment and minimize the length of the ground wire. Improper equipment grounding may cause dangerous electrical potentials on equipment chassis, which could result in death or serious injury.

WARNING! *Electrical Shock Hazard. Be sure to ground the drive ground terminal (200 V class: ground to 100 Ω or less; 400 V class: ground to 10 Ω or less). Improper equipment grounding could result in death or serious injury by contacting ungrounded electrical equipment.*

NOTICE: *Do not share the ground wire with other devices such as welding machines or large-current electrical equipment. Improper equipment grounding could result in drive or equipment malfunction due to electrical interference.*

NOTICE: *When using more than one drive, ground multiple drives according to instructions. Improper equipment grounding could result in abnormal operation of drive or equipment.*

Refer to [Figure 3.31](#) when using multiple drives or when using multiple drive models 4□0720 to 4□0930 that are connected with harmonic filter module. Do not loop the ground wire.

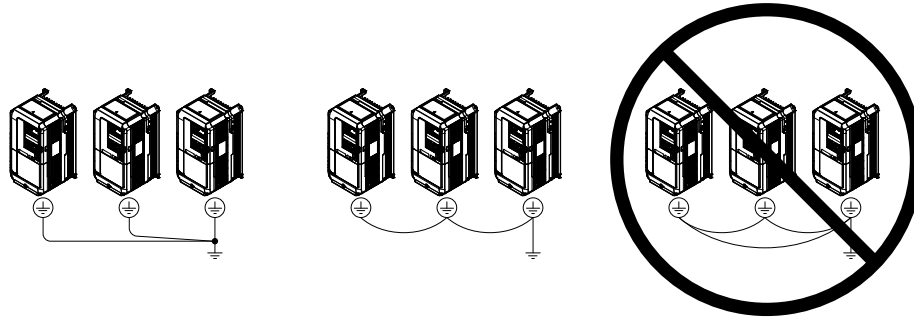

Figure 3.31 Multiple Drive Wiring

■ Wiring the Main Circuit Terminal

WARNING! *Electrical Shock Hazard. Shut off the power supply to the drive before wiring the main circuit terminals. Failure to comply may result in death or serious injury.*

Wire the main circuit terminals after the terminal board has been properly grounded.

Drive Models 2□0028 to 2□0081 and 4□0011 to 4□0077 have a cover placed over terminals p1 and n1 prior to shipment to help prevent miswiring. Use wire cutters to cut away covers as needed for terminals.

3.9 Control Circuit Wiring

◆ Control Circuit Connection Diagram

Refer to [Figure 3.1](#) on page 67 when wiring terminals on the drive control circuit.

◆ Control Circuit Terminal Block Functions

Drive parameters determine which functions apply to the multi-function digital inputs (S1 to S8), multi-function digital outputs (M1 to M4), multi-function analog inputs (A1 to A3), and multi-function analog monitor output (FM, AM). The default setting is listed next to each terminal in [Figure 3.1](#) on page 67.

WARNING! Sudden Movement Hazard. Always check the operation and wiring of control circuits after being wired. Operating a drive with untested control circuits could result in death or serious injury.

WARNING! Sudden Movement Hazard. Confirm the drive I/O signals and external sequence before starting test run. Setting parameter A1-03 may change the I/O terminal function automatically from the factory setting. Failure to comply may result in death or serious injury.

■ Terminal Configuration

The control circuit terminals should be arranged as shown in [Figure 3.32](#).

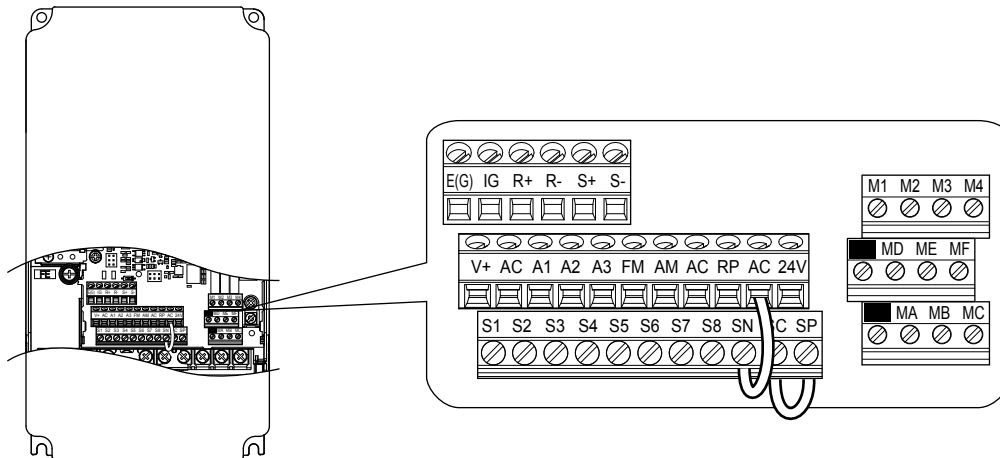

Figure 3.32 Control Circuit Terminal Arrangement

Input Terminals

Table 3.9 lists the input terminals on the drive. Text in parenthesis indicates the default setting for each multi-function input.

Table 3.9 Control Circuit Input Terminals

Type	No.	Terminal Name (Function)	Function (Signal Level) Default Setting	Page
Multi-Function Digital Inputs	S1	Multi-function input 1 (Closed: Forward run, Open: Stop)	<ul style="list-style-type: none"> • Photocoupler • 24 Vdc, 8 mA • <i>Refer to Sinking/Sourcing Mode for Digital Inputs on page 102.</i> 	344
	S2	Multi-function input 2 (Through mode)		
	S3	Multi-function input 3 (External pump fault, N.O.)		
	S4	Multi-function input 4 (Fault reset)		
	S5	Multi-function input 5 (Multi setpoint 1)		
	S6	Multi-function input 6 (HAND mode)		
	S7	Multi-function input 7 (HAND mode 2)		
	S8	Multi-function input 8 (Through mode)		
	SC	Multi-function input common		
	SP	Digital input power supply +24 Vdc	24 Vdc power supply for digital inputs, 150 mA max	102
SN	Digital input power supply 0 V 24 V transducer power supply 0 V	NOTICE: Do not jumper or short terminals SP and SN. Failure to comply will damage the drive.	102	
Analog Inputs / Pulse Train Input	RP	Multi-function pulse train input (Frequency reference)	<ul style="list-style-type: none"> • Input frequency range: 0 to 32 kHz • Signal Duty Cycle: 30 to 70% • High level: 3.5 to 13.2 Vdc, low level: 0.0 to 0.8 Vdc • Input impedance: 3 kΩ 	170 356
	+V	Power supply for analog inputs	10.5 Vdc (maximum allowable current 20 mA)	168
	24 V	+24 Vdc transducer power supply for customer use	150 mA maximum capacity	–
	A1	Multi-function analog input 1 (Frequency reference bias)	<ul style="list-style-type: none"> • -10 to 10 Vdc, 0 to 10 Vdc (input impedance: 20 kΩ) • 4 to 20 mA, 0 to 20 mA (input impedance: 250 Ω) • Voltage or current input must be selected by jumper S1 and H3-01. 	168 178
	A2	Multi-function analog input 2 (PID feedback)	<ul style="list-style-type: none"> • -10 to 10 Vdc, 0 to 10 Vdc (input impedance: 20 kΩ) • 4 to 20 mA, 0 to 20 mA (input impedance: 250 Ω) • Voltage or current input must be selected by jumper S1 and H3-09. 	168 168 180
	A3	Multi-function analog input 3 (HAND frequency reference)	<ul style="list-style-type: none"> • -10 to 10 Vdc, 0 to 10 Vdc (input impedance: 20 kΩ) • 4 to 20 mA, 0 to 20 mA (input impedance: 250 Ω) • Voltage or current input must be selected by jumper S1 and H3-05. 	168
	AC	Frequency reference common	0 V	168
	E (G)	Ground for shielded lines and option cards	–	–

3.9 Control Circuit Wiring

Output Terminals

[Table 3.10](#) lists the output terminals on the drive. Text in parenthesis indicates the default setting for each multi-function output.

Table 3.10 Control Circuit Output Terminals

Type	No.	Terminal Name (Function)	Function (Signal Level) Default Setting	Page
Fault Relay Output	MA	N.O.	30 Vdc, 10 mA to 1 A; 250 Vac, 10 mA to 1 A Minimum load: 5 Vdc, 10 mA	177
	MB	N.C. output		
	MC	Fault output common		
Multi-Function Digital Output <1>	MD	N.O.	30 Vdc, 10 mA to 1 A; 250 Vac, 10 mA to 1 A Minimum load: 5 Vdc, 10 mA	177
	ME	N.C. Output		
	MF	Common (Speed agree)		
	M1	Multi-function digital output (During frequency output)		
	M2			
M3	Multi-function digital output (Through mode)			
M4				
Monitor Output	FM	Analog monitor output 1 (Output frequency)	-10 to +10 Vdc, or 0 to +10 Vdc	354
	AM	Analog monitor output 2 (Output current)		
	AC	Monitor common	0 V	—

<1> Refrain from assigning functions to digital relay outputs that involve frequent switching, as doing so may shorten relay performance life. Switching life is estimated at 200,000 times (assumes 1 A, resistive load).

Serial Communication Terminals

Table 3.11 Control Circuit Terminals: Serial Communications

Type	No.	Signal Name	Function (Signal Level)	
MEMOBUS/Modbus Communication <1>	R+	Communications input (+)	MEMOBUS/Modbus communication: Use an RS-422 or RS-485 cable to connect the drive.	RS-422/RS-485 MEMOBUS/Modbus communication protocol 115.2 kbps (maximum)
	R-	Communications input (-)		
	S+	Communications output (+)		
	S-	Communications output (-)		
	IG	Shield ground	0 V	

<1> Enable the termination resistor in the last drive in a MEMOBUS/Modbus network by setting DIP switch S2 to the ON position. [Refer to MEMOBUS/Modbus Termination on page 106](#) for more information.

Wire Size and Torque Specifications

Select appropriate wire type and gauges from [Table 3.12](#). For simpler and more reliable wiring, use crimp ferrules on the wire ends. Refer to [Table 3.13](#) for ferrule terminal types and sizes.

Table 3.12 Wire Gauges

Terminal	Screw Size	Tightening Torque N•m (lb. in)	Bare Wire Terminal		Ferrule-Type Terminal		Wire Type
			Applicable wire size mm ² (AWG)	Recomm. wire size mm ² (AWG)	Applicable wire size mm ² (AWG)	Recomm. wire size mm ² (AWG)	
S1-S8, SC, SN, SP	M3	0.5 to 0.6 (4.4 to 5.3)	Stranded wire: 0.2 to 1.0 (24 to 16) Solid wire: 0.2 to 1.5 (24 to 16)	0.75 (18)	0.25 to 0.5 (24 to 20)	0.5 (20)	Shielded wire, etc.
RP, V+, A1, A2, A3, AC, 24 V							
MA, MB, MC, MD, ME, MF							
M1-M4							
FM, AM, AC							
R+, R-, S+, S-, IG							

■ Ferrule-Type Wire Terminals

Yaskawa recommends using CRIMPFOX 6, a crimping tool manufactured by PHOENIX CONTACT, to prepare wire ends with insulated sleeves before connecting to the drive. See [Table 3.13](#) for dimensions.

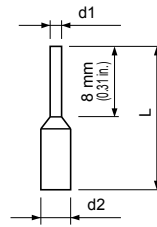

Figure 3.33 Ferrule Dimensions

Table 3.13 Ferrule Terminal Types and Sizes

Size mm ² (AWG)	Type	L mm (in)	d1 mm (in)	d2 mm (in)	Manufacturer
0.25 (24)	AI 0.25-8YE	12.5 (0.49)	0.8 (0.03)	2.0 (0.08)	PHOENIX CONTACT
0.34 (22)	AI 0.34-8TQ	12.5 (0.49)	0.8 (0.03)	2.0 (0.08)	
0.5 (20)	AI 0.5-8WH AI 0.5-8OG	14.0 (0.55)	1.1 (0.04)	2.5 (0.10)	

◆ Wiring the Control Circuit Terminal

This section describes the proper procedures and preparations for wiring the control terminals.

WARNING! *Electrical Shock Hazard. Do not remove covers or touch the circuit boards while the power is on. Failure to comply could result in death or serious injury.*

NOTICE: *Separate control circuit wiring from main circuit wiring (terminals R/L1, S/L2, T/L3, B1, B2, U/T1, V/T2, W/T3, e, e1, e2) and other high-power lines. Improper wiring practices could result in drive malfunction due to electrical interference.*

NOTICE: *Separate wiring for digital output terminals MA, MB, MC, MD, ME, MF and M1 to M4 from wiring to other control circuit lines. Improper wiring practices could result in drive or equipment malfunction or nuisance trips.*

NOTICE: *Use a class 2 power supply when connecting to the control terminals. Improper application of peripheral devices could result in drive performance degradation due to improper power supply. Refer to NEC Article 725 Class 1, Class 2, and Class 3 Remote-Control, Signaling, and Power Limited Circuits for requirements concerning class 2 power supplies.*

NOTICE: *Insulate shields with tape or shrink tubing to prevent contact with other signal lines and equipment. Improper wiring practices could result in drive or equipment malfunction due to short circuit.*

NOTICE: *Connect the shield of shielded cable to the appropriate ground terminal. Improper equipment grounding could result in drive or equipment malfunction or nuisance trips.*

NOTICE: *Do not tighten screws beyond the specified tightening torque. Failure to comply may result in erroneous operation, damage to the terminal block, or cause a fire.*

NOTICE: *Use shielded twisted-pair cables as indicated to prevent operating faults. Improper wiring practices could result in drive or equipment malfunction due to electrical interference.*

Wire the control circuit only after terminals have been properly grounded and main circuit wiring is complete. [Refer to Terminal Board Wiring Guide on page 98](#) for details. Prepare the ends of the control circuit wiring as shown in [Figure 3.36](#). [Refer to Wire Gauges on page 96](#).

Connect control wires as shown in [Figure 3.34](#) and [Figure 3.35](#).

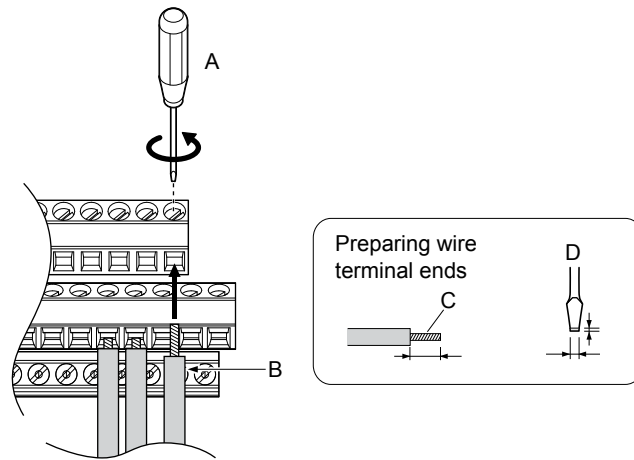

A – Loosen screw to insert wire.
 B – Single wire or stranded wire

C – Avoid fraying wire strands when stripping insulation from wire. Strip length 5.5 mm.
 D – Blade depth of 0.4 mm or less
 Blade width of 2.5 mm or less

Figure 3.34 Terminal Board Wiring Guide

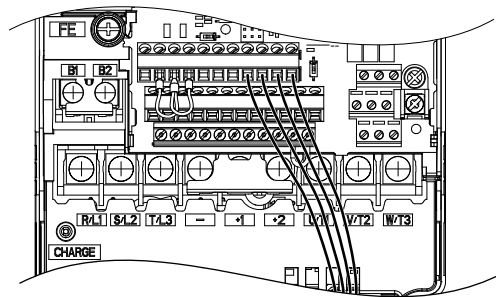
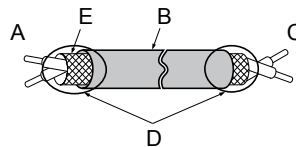

Figure 3.35 Terminal Board Location Inside the Drive

When setting the frequency by analog reference from an external potentiometer, use shielded twisted-pair wires (preparing wire ends as shown in [Figure 3.36](#)) and connect the shield to the ground terminal of the drive.



A – Drive side
 B – Insulation
 C – Control device side

D – Shield sheath (insulate with tape)
 E – Shield

Figure 3.36 Preparing the Ends of Shielded Cables

NOTICE: The analog signal wiring between the drive and the operator station or peripheral equipment should not exceed 50 meters when using an analog signal from a remote source to supply the frequency reference. Failure to comply could result in poor system performance.

◆ Module Communications Connector

The module communications connector port allows the transfer of information to enable turning on and operating drive models 4□0720 to 4□0930 and the filter module.

Note: Connect the drive and filter module before turning on or operating models 4□0720 to 4□0930.

Refer to Drive Standard Connection Diagram (Example: Model 4□0720) on page 69 for more information on module communications connector functions.

■ Module Communications Connector Locations

Connect drive models 4□0720 to 4□0930 to the filter module using the module communications connector cable packaged with the filter module.

Connect one end of the cable to the module communications connector port CN500 of the drive and the other end of the cable to the module communications connector port CN500 of the filter module.

Insert both ends of the cable then gently pull the cable to ensure a secure connection.

Drive Models 4□0720 to 4□0930

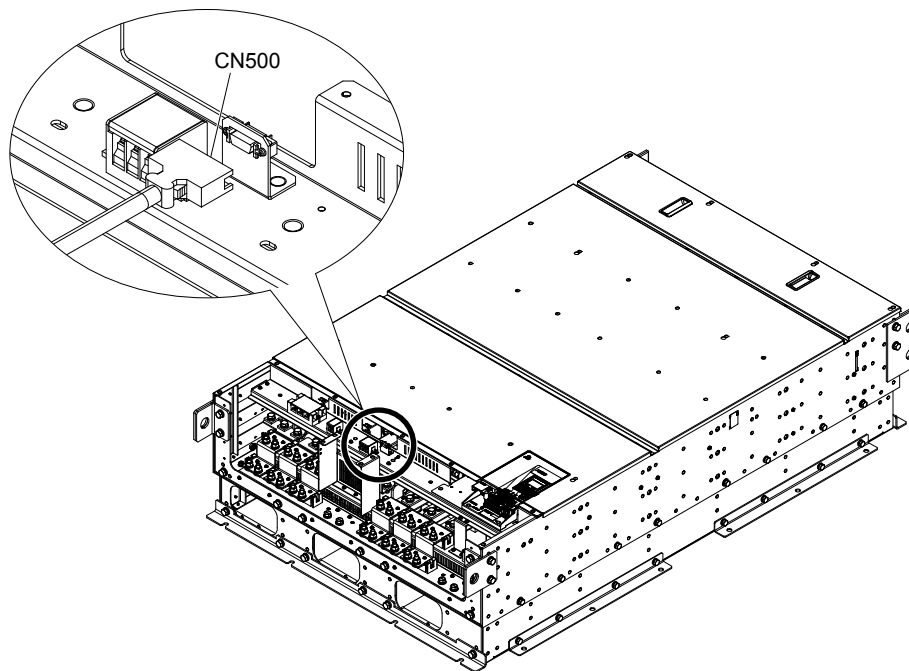

Figure 3.37 Module Communications Connector Port CN500 Location

3.9 Control Circuit Wiring

Filter Module

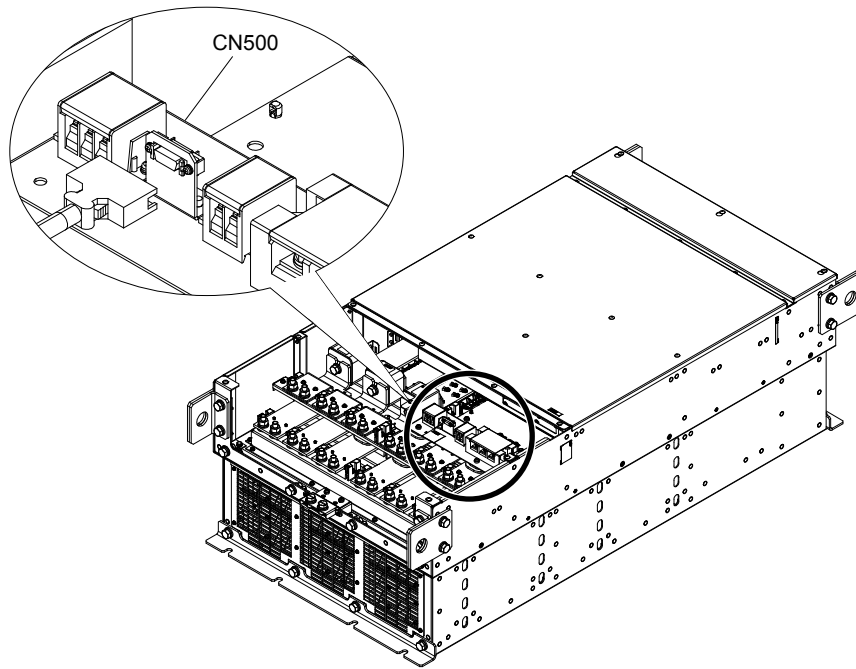
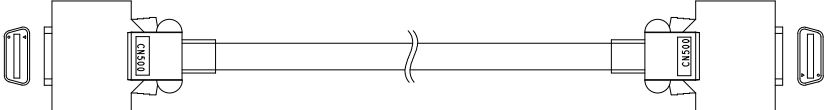

Figure 3.38 Module Communications Connector Port CN500 Location

■ Cable Specifications

Table 3.14 Module Communications Connector Cable Specifications

Cable Length	Cable Connector Exterior	Cable Example
Approximately 5 m (16.4 ft)	Half-pitch I/O connector (1.27 mm [0.05 in.])	

◆ Switches and Jumpers on the Terminal Board

The terminal board is equipped with several switches used to adapt the drive I/Os to the external control signals. *Figure 3.39* shows the location of these switches.

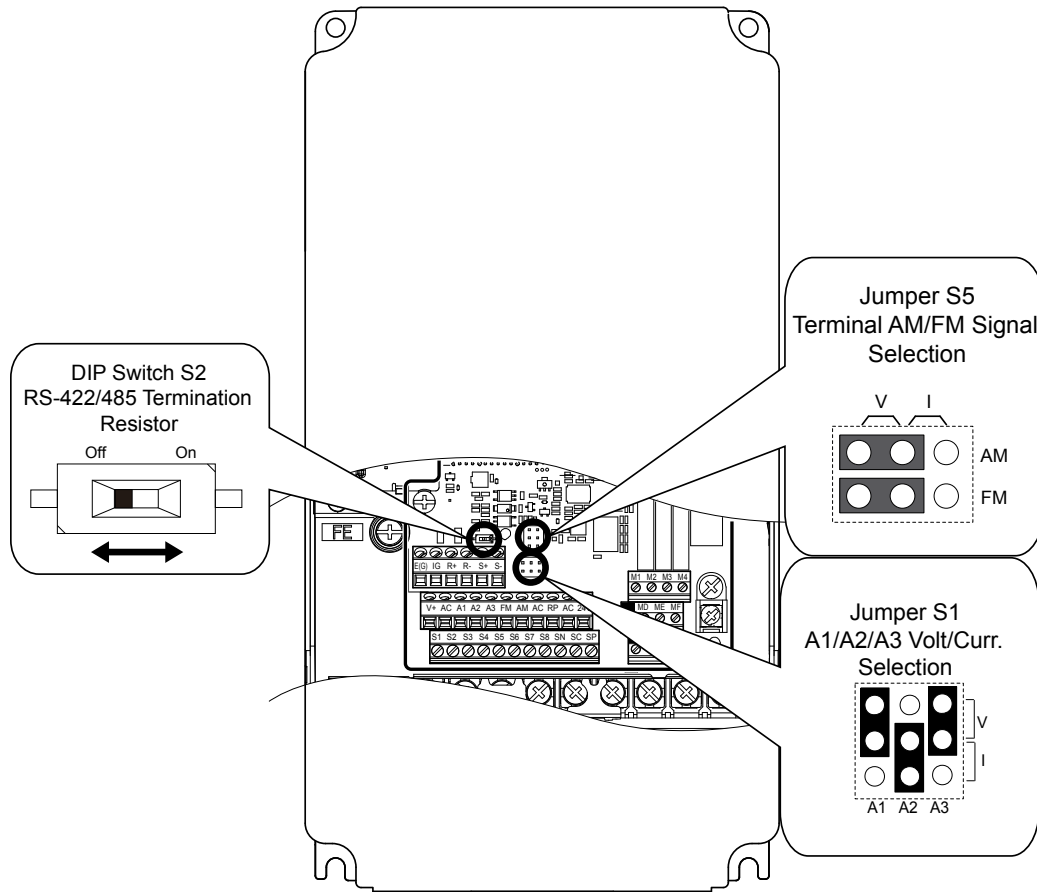

Figure 3.39 Locations of Jumpers and Switches on the Terminal Board

3.10 Control I/O Connections

◆ Sinking/Sourcing Mode for Digital Inputs

Use the wire jumper between terminals SC and SP or SC and SN to select between Sink mode, Source mode or external power supply for the digital inputs S1 to S8 as shown in [Table 3.15](#) (Default: Sink mode, internal power supply).

NOTICE: Do not short terminals SP and SN. Failure to comply will damage the drive.

Table 3.15 Digital Input Sink/Source/External Power Supply Selection

Mode	Drive Internal Power Supply (Terminals SN and SP)	External 24 Vdc Power Supply
Sinking Mode (NPN)		
Sourcing Mode (PNP)		

◆ Terminals A1, A2, and A3 Input Signal Selection

Terminals A1, A2, and A3 can be used to input either a voltage or a current signal. Select the signal type using jumper S1 as explained in [Table 3.16](#). Set parameters H3-01, H3-05, and H3-09 accordingly as shown in [Table 3.17](#).

Note: If terminals A1 and A2 are both set for frequency bias (H3-02 = 0 and H3-10 = 0), both input values will be combined to create the frequency reference.

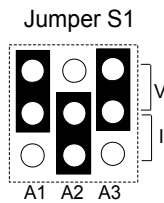

Figure 3.40 Terminal A2 Set to Current Input; A1 and A3 Set to Voltage Input

Table 3.16 Jumper S1 Settings

Setting	Description
V (top position)	Voltage input (-10 to +10 V or 0 to 10 V)
I (bottom position)	Current input (4 to 20 mA or 0 to 20 mA)

Table 3.17 Voltage/Current Selection Parameter Details

No.	Parameter Name	Description	Setting Range	Default Setting
H3-01	Terminal A1 signal level selection	Selects the signal level for terminal A1. 0: 0 to 10 Vdc 1: 0 to 10 Vdc Bipolar 2: 4 to 20 mA 3: 0 to 20 mA	0 to 3	0
H3-05	Terminal A3 signal level selection	Selects the signal level for terminal A3. 0: 0 to 10 Vdc 1: 0 to 10 Vdc Bipolar 2: 4 to 20 mA 3: 0 to 20 mA	0 to 3	0
H3-09	Terminal A2 signal level selection	Selects the signal level for terminal A2. 0: 0 to 10 Vdc 1: 0 to 10 Vdc Bipolar 2: 4 to 20 mA 3: 0 to 20 mA	0 to 3	2

■ Transducer Wiring

Simplex Pump System - Transducer Connection using Analog Input A2 (4 to 20 mA Mode)

A2 used for pressure transducer. Example of retrofit application where an external power supply is used.

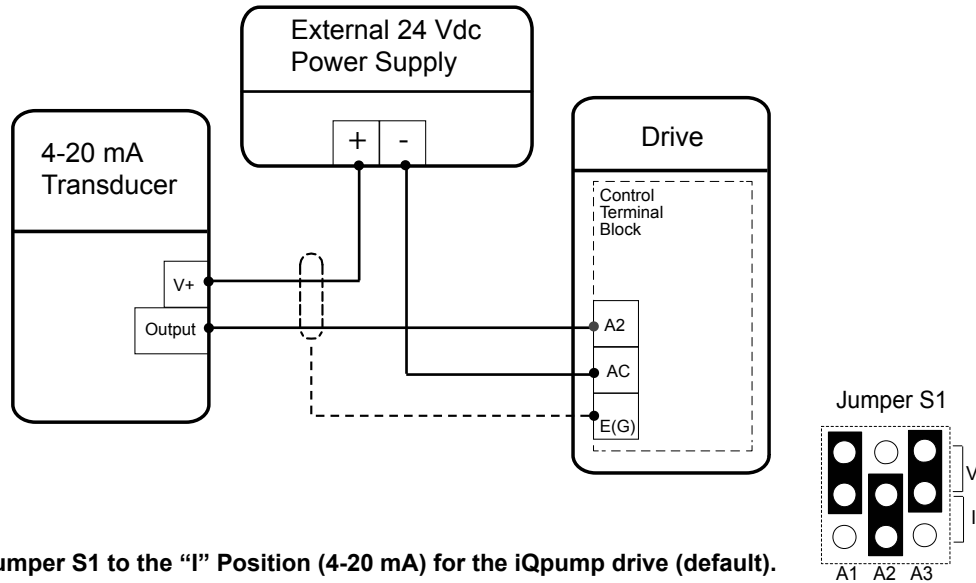

A2 used for pressure transducer. Example of new application where internal power supply is used

(2-Wire Transducer)

Example:
Customer supplied
pressure transducer
feedback device

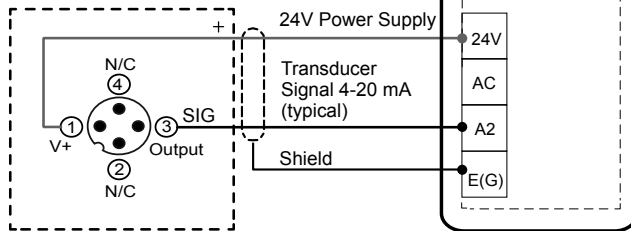

(3-Wire Transducer)

Example:
Customer supplied
pressure transducer
feedback device

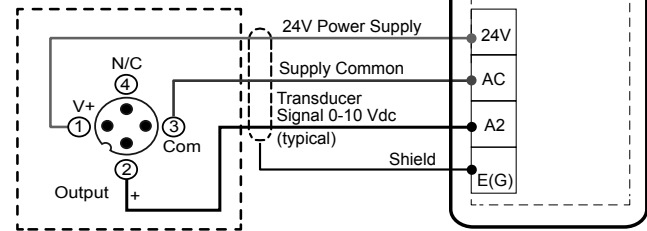

Duplex System: Single Transducer Connection using Analog Input A2

A2 used for pressure transducer.

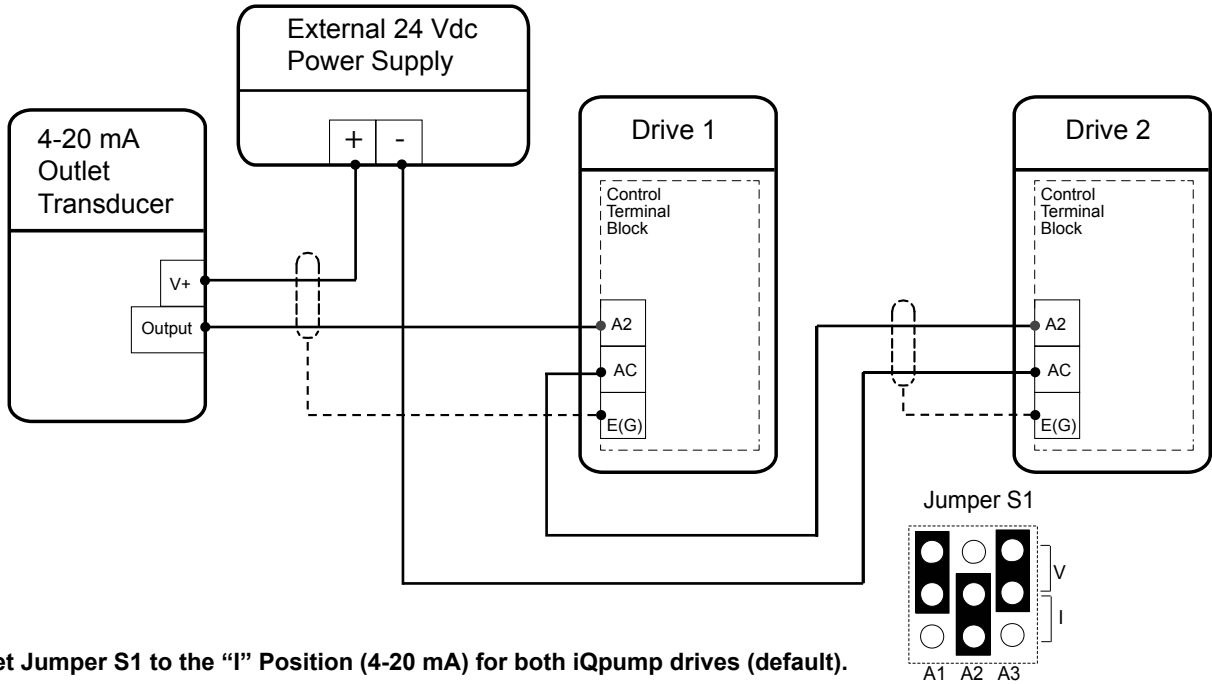

Set Jumper S1 to the "I" Position (4-20 mA) for both iQpump drives (default).

Triplex System: Transducer Connection using Analog Input A2

A2 used for water level or suction pressure transducer.

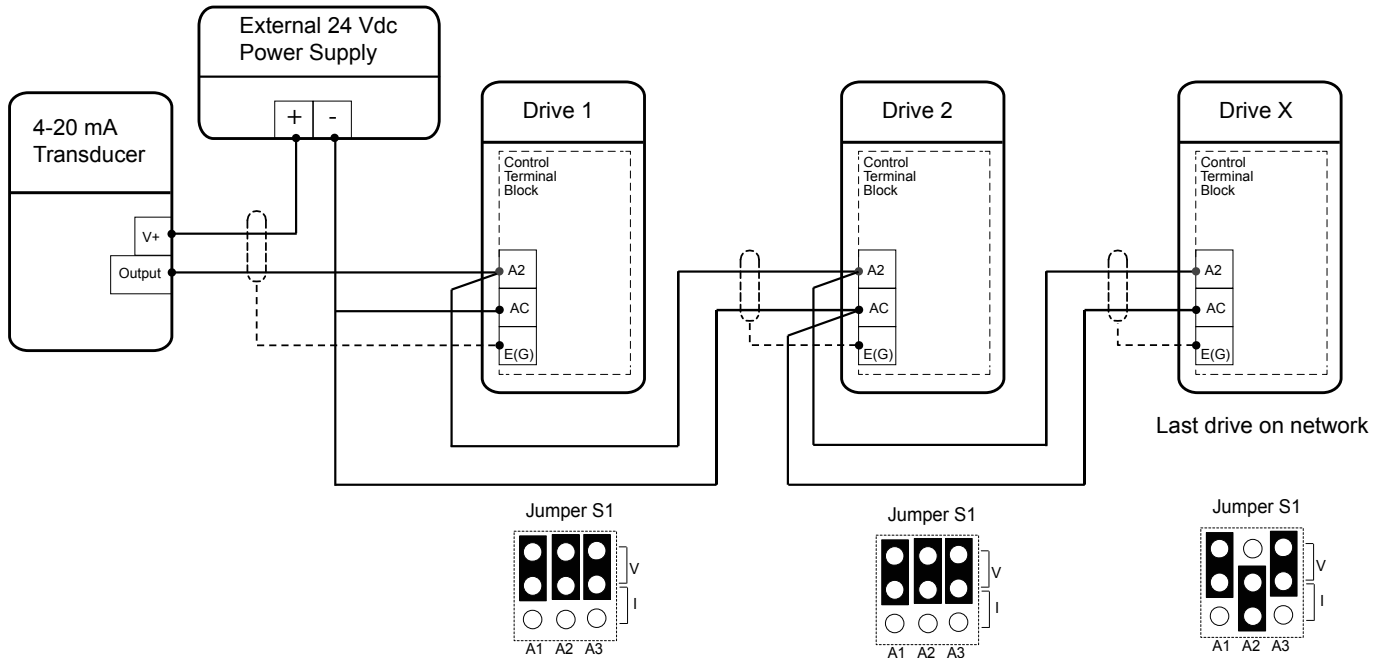

Set jumper S1 to the "I" position for the last iQpump drive on the network. All other iQpump drives should have S1 set to the "V" position.

◆ Terminal AM/FM Signal Selection

The signal type for terminals AM and FM can be set to either voltage or current output using jumper S5 on the terminal board as explained in [Table 3.18](#). When changing the setting of jumper S5, parameters H4-07 and H4-08 must be set accordingly. The default selection is voltage output for both terminals.

Table 3.18 Jumper S5 Settings





Terminal	Voltage Output	Current Output
Terminal AM		
Terminal FM		

Table 3.19 Parameter H4-07 and H4-08 Details

No.	Parameter Name	Description	Setting Range	Default Setting
H4-07	Terminal FM signal level selection	0: 0 to 10 Vdc 1: -10 to 10 Vdc	0 to 2	0
H4-08	Terminal AM signal level selection	2: 4 to 20 mA		

◆ MEMOBUS/Modbus Termination

This drive is equipped with a built-in termination resistor for the RS-422/RS-485 communication port. DIP switch S2 enables or disabled the termination resistor as shown in [Table 3.20](#). The OFF position is the default. The termination resistor should be placed to the ON position when the drive is the last in a series of slave drives.

Table 3.20 MEMOBUS/Modbus Switch Settings

S2 Position	Description
ON	Internal termination resistor ON
OFF	Internal termination resistor OFF (default setting)

◆ Terminal A2 Input Signal Selection

Terminal A2 can be used to input either a voltage or a current signal. Select the signal type using switch S1 as explained in [Table 3.16](#). Set parameter H3-09 accordingly as shown in [Table 3.17](#).

Note: If terminals A1 and A2 are both set for frequency bias (H3-02 = 0 and H3-10 = 0), both input values will be combined to create the frequency reference.

Table 3.21 DIP Switch S1 Settings

Setting	Description
V (left position)	Voltage input (-10 to +10 V or 0 to 10 V)
I (right position)	Current input (4 to 20 mA or 0 to 20 mA); default setting

Table 3.22 Parameter H3-09 Details

No.	Parameter Name	Description	Setting Range	Default Setting
H3-09	Terminal A2 Signal Level Selection	Selects the signal level for terminal A2. 0: 0 to 10 Vdc 1: -10 to 10 Vdc 2: 4 to 20 mA 3: 0 to 20 mA	0 to 3	2

3.11 Connect to a PC

This drive is equipped with a USB port (type-B).

The drive can connect to a USB port on a PC using a USB 2.0, AB-type cable (sold separately). After connecting the drive to a PC, Yaskawa DriveWizard Industrial software can be used to monitor drive performance and manage parameter settings. Contact Yaskawa or a Yaskawa representative for more information on DriveWizard Industrial.

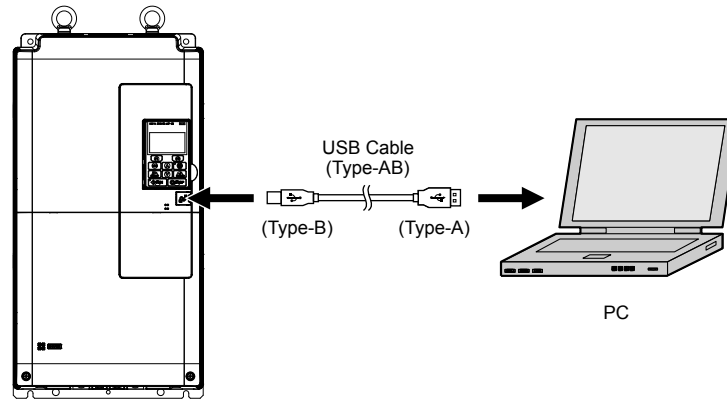



Figure 3.41 Connecting to a PC (USB)

3.12 Wiring Checklist

<input checked="" type="checkbox"/>	No.	Item	Page(s)
Drive, Peripherals, Option Cards			
<input type="checkbox"/>	1	Check drive model number to ensure receipt of correct model.	–
Drive, Peripherals, Option Cards			
<input type="checkbox"/>	2	Make sure you have the correct peripheral devices.	–
<input type="checkbox"/>	3	Check the option card model number.	–
Installation Area and Physical Setup			
<input type="checkbox"/>	4	Ensure that the area surrounding the drive complies with specifications.	44
Power Supply Voltage, Output Voltage			
<input type="checkbox"/>	5	The voltage from the power supply should be within the input voltage specification range of the drive.	–
<input type="checkbox"/>	6	The voltage rating for the motor should match the drive output specifications.	25
<input type="checkbox"/>	7	Verify that the drive is properly sized to run the motor.	
Main Circuit Wiring			
<input type="checkbox"/>	8	Confirm proper branch circuit protection as specified by national and local codes.	–
<input type="checkbox"/>	9	Properly wire the power supply to drive terminals R/L1, S/L2, and T/L3.	71
<input type="checkbox"/>	10	Properly wire the drive and motor together. The motor lines and drive output terminals U/T1, V/T2, and W/T3 should match in order to produce the desired phase order. If the phase order is incorrect, the drive will rotate in the opposite direction.	92
<input type="checkbox"/>	11	Use 600 Vac vinyl-sheathed wire for the power supply and motor lines. Wire gauge recommendations based on using 75 °C (167 °F), 600 Vac vinyl-sheathed wire.	86
<input type="checkbox"/>	12	Use the correct wire gauges for the main circuit. <ul style="list-style-type: none"> Consider the amount of voltage drop when selecting wire gauges. Increase the wire gauge when the voltage drop is greater than 2% of motor rated voltage. Ensure the wire gauge is suitable for the terminal block. Use the following formula to calculate the amount of voltage drop: Line drop voltage (V) = $\sqrt{3} \times \text{wire resistance } (\Omega/\text{km}) \times \text{wire length (m)} \times \text{current (A)} \times 10^{-3}$ If the cable between the drive and motor exceeds 50 m, adjust the carrier frequency set to C6-02 accordingly. 	86
<input type="checkbox"/>	13	Properly ground the drive.	92
<input type="checkbox"/>	14	Tighten control circuit and grounding terminal screws.	86
<input type="checkbox"/>	15	Verify phase advancing capacitors, input noise filters, or GFCIs are NOT installed on the output side of the drive.	–
<input type="checkbox"/>	16	Properly wire the power lines to terminals X, Y, and Z of drive models 4□0720 to 4□0930, and terminals X, Y, and Z of the harmonic filter module.	84
<input type="checkbox"/>	17	Properly wire the power lines to terminals X1, Y1, and Z1 of drive models 4□0720 to 4□0930, and terminals X1, Y1, and Z1 of the harmonic filter module.	
<input type="checkbox"/>	18	Properly wire the power lines to terminals p2 and n2 of mdrive models 4□0720 to 4□0930, and terminals p2 and n2 of the harmonic filter module.	
<input type="checkbox"/>	19	The cable between drive models 4□0720 to 4□0930 and harmonic filter module should not exceed 5 m (16.4 ft.).	84
<input type="checkbox"/>	20	The resistance value between the terminals R/L1, S/L2, and T/L3 of the harmonic filter module should exceed 1000 Ω when connected to drive models 4□0720 to 4□0930. If the resistance value does not exceed 1000 Ω, check for main circuit wiring mistakes between the harmonic filter module and drive models 4□0720 to 4□0930.	84
Control Circuit Wiring			
<input type="checkbox"/>	21	Use twisted-pair line for all drive control circuit wiring.	97
<input type="checkbox"/>	22	Ground the shields of shielded wiring to the GND  terminal.	97
<input type="checkbox"/>	23	For 3-Wire sequence, set parameters for multi-function contact input terminals S1 – S8, and wire control circuits.	–
<input type="checkbox"/>	24	Properly wire any option cards.	97
<input type="checkbox"/>	25	Check for any other wiring mistakes. Only use a multimeter to check wiring.	–
<input type="checkbox"/>	26	Properly fasten drive control circuit terminal screws.	86
<input type="checkbox"/>	27	Pick up all wire clippings.	–
<input type="checkbox"/>	28	Ensure that no frayed wires on the terminal block are touching other terminals or connections.	–

<input checked="" type="checkbox"/>	No.	Item	Page(s)
<input type="checkbox"/>	29	Properly separate control circuit wiring and main circuit wiring.	-
<input type="checkbox"/>	30	Analog signal line wiring should not exceed 50 m (164 ft.).	-
<input type="checkbox"/>	31	Properly wire the control signal lines to Module Communications Connector port CN500 of drive models 4□0720 to 4□0930, and Module Communications Connector port CN500 of the harmonic filter module.	99
<input type="checkbox"/>	32	The cable between drive models 4□0720 to 4□0930 and harmonic filter module should not exceed 5 m (16.4 ft.).	

This Page Intentionally Blank

Start-Up Programming & Operation

This chapter explains startup procedures, HOA keypad functions, gives instructions on programming the drive for initial operation, and other important functions.

4.1	DRIVE START-UP PREPARATION.....	112
4.2	POWERING UP THE DRIVE.....	114
4.3	APPLICATION SELECTION.....	117
4.4	USING THE HOA KEYPAD.....	118
4.5	PUMP APPLICATION PRESETS.....	125
4.6	U1000 IQPUMP PRESETS AND FUNCTIONS.....	128
4.7	BASIC U1000 IQPUMP SETUP AND APPLICATION PRESET PARAMETERS.....	163
4.8	TEST RUN WITH NO LOAD.....	199
4.9	TEST RUN WITH LOAD CONNECTED.....	200

4.1 Drive Start-Up Preparation

4.1 Drive Start-Up Preparation

To provide the most reliable drive available and to avoid any extra costs related to loss or reduction of warranty coverage, an authorized Yaskawa service representative should complete this start-up procedure. Please complete the following checklist and maintain it in a secure location, as technical service personnel may request information from this checklist.

Note: Refer to *Powering Up the Drive on page 114* prior to powering up the drive for the first time.

Date: _____

Start-Up Person:

Company Name: _____ Start-Up Location: _____

Sales Order #: _____ Serial #: _____

Printed Name: _____ Drive Location: _____

Phone #: _____ Signature: _____

Owner's Representative:

Printed Name: _____ Phone #: _____

Company: _____ Signature: _____

◆ Start-Up Checklist

<input checked="" type="checkbox"/>	No.	Item
<input type="checkbox"/>	1	The drive is thoroughly tested at the factory. The start up person should verify that the drive is free of shipping and installation damage. Shipping damage is not covered by the Yaskawa warranty. Claims must be filed with the shipping company as soon as possible for any potential recovery via insurance.
<input type="checkbox"/>	2	Review the U1000 iQpump Quick Start Procedure shipped with the drive.
<input type="checkbox"/>	3	Verify that the model number and voltage ratings in the purchase order match the nameplate data for each unit.
<input type="checkbox"/>	4	The location of the drive is important to achieve proper performance and normal operating life. <i>Refer to Drive Installation Environment on page 44</i> for details.
<input type="checkbox"/>	5	Ensure the drive is on a vertical surface with adequate space for air circulation. <i>Refer to Correct Drive Installation Spacing on page 46</i> for proper spacing.
<input type="checkbox"/>	6	Verify that the proper branch circuit protection is installed in front of the drive. <i>Refer to Branch Circuit Protection on page 467</i> for proper input fuse or circuit breaker sizing.
<input type="checkbox"/>	7	NOTICE: Separate control circuit wiring from main circuit wiring (terminals R/L1, S/L2, T/L3, B1, B2, U/T1, V/T2, W/T3, -, +1, +2) and other high-power lines. Improper wiring practices could result in drive malfunction due to electrical interference.
<input type="checkbox"/>	8	NOTICE: Insulate shields with tape or shrink tubing to prevent contact with other signal lines and equipment. Improper wiring practices could result in drive or equipment malfunction due to short circuit.
<input type="checkbox"/>	9	WARNING! Electrical Shock Hazard. Do not connect the AC power line to the output terminals of the drive. Failure to comply could result in death or serious injury by fire as a result of drive damage from line voltage application to output terminals.
<input type="checkbox"/>	10	NOTICE: Do not connect phase-advancing capacitors or LC/RC noise filters to the output circuits. Failure to comply could result in damage to the drive, phase-advancing capacitors, LC/RC noise filters or ground fault circuit interrupters.
<input type="checkbox"/>	11	Use crimp insulated terminals or insulated shrink tubing for wiring connections. Wires should have a continuous maximum allowable temperature of 75 °C 600 Vac UL-approved vinyl-sheathed insulation. Consider the amount of voltage drop when selecting wire gauges. Increase the wire gauge when the voltage drop is greater than 2% of motor rated voltage. Ensure the wire gauge is suitable for the terminal block. Use the following formula to calculate the amount of voltage drop: Line drop voltage (V) = 3 × wire resistance (Ω/km) × wire length (m) × current (A) × 10 ⁻³
<input type="checkbox"/>	12	If the cable between the drive and motor exceeds 50 m (164 ft.), adjust the carrier frequency set C6-02 accordingly.
<input type="checkbox"/>	13	Determine proper wire size for power and motor leads.

<input checked="" type="checkbox"/>	No.	Item
<input type="checkbox"/>	14	<p>WARNING! Always ground the ground terminal. (200 V Class: Ground to 100 Ω or less, 400 V Class: Ground to 10 Ω or less). Improper equipment grounding could result in death or serious injury by contacting ungrounded electrical equipment.</p> <p>When using multiple drives, ground each drive directly or daisy-chain to the ground pole(s). DO NOT FORM A LOOP WITH THE GROUND LEADS. <i>Refer to Multiple Drive Wiring on page 93.</i></p>
<input type="checkbox"/>	15	Review terminal functions of signal and control circuits.
<input type="checkbox"/>	16	Verify if any customer safety devices are required (e.g. External Pump Fault).
<input type="checkbox"/>	17	Record the following motor nameplate information: Voltage: _____ Motor Rated Amps: _____
<input type="checkbox"/>	18	Verify that the commercial power supply is within the rated drive input voltage: Power Supply: _____ Vac Drive Input Voltage: _____ Vac
<input type="checkbox"/>	19	Verify that the leads in the three-phase electric motor conduit box are configured for the proper voltage.
<input type="checkbox"/>	20	Ensure Motor Rated Current is less than or equal to drive output amps. If multiple motors are being used, make sure that the Motor Rated Current sum is less than or equal to drive output amp rating. Please note that if multiple motors are being operated from one drive, each motor must have its own overload and short circuit protection.
<input type="checkbox"/>	21	Wire all necessary power leads to the drive. DO NOT CONNECT MOTOR TO DRIVE AT THIS TIME.
<input type="checkbox"/>	2	Wire all necessary ground wires to the drive.
<input type="checkbox"/>	23	Wire all necessary control wires to the drive.
<input type="checkbox"/>	24	Ensure that the power leads are connected to the R/L1, S/L2 and T/L3 terminals in the drive. Confirm single-phase input or three-phase input wiring.
<input type="checkbox"/>	25	Tighten all of the three-phase power and ground connections. Please check that all control and signal terminations are tight.
<input type="checkbox"/>	26	Inspect the control circuit connections (including the shield) and determine if a motor safety circuit is connected. If normally closed, these contacts may be wired in series with the RUN command contacts, which are between terminals S1 and SN of the drive. No special programming is required. Alternately, these contacts could be wired between terminals S3 and SN as External Fault Inputs, and may be either normally closed or normally open contacts.
<input type="checkbox"/>	27	Record any other connections to the drive to determine if special programming is required for the following: Multi-function Inputs Multi-function Outputs Multi-function Digital Inputs Multi-function Analog Outputs Network Communications

4.2 Powering Up the Drive

Review the following table before applying power.

Item to Check	Description
Power supply voltage	200 V class: Three-phase/Single-phase 200 to 240 Vac 50/60 Hz 400 V class: Three-phase/Single-phase 380 to 480 Vac 50/60 Hz
	Properly wire the power supply input terminals (R/L1, S/L2, T/L3).
	Check for proper grounding of drive and motor.
Drive output terminals and motor terminals	Properly wire drive output terminals U/T1, V/T2, and W/T3 with motor terminals U, V, and W.
Control circuit terminals	Check control circuit terminal connections.
Drive control terminal status	Open all control circuit terminals (off).
Status of the load and connected machinery	Decouple the motor from the load.

◆ Setting the Real Time Clock

The time and date must be set when a new HOA keypad is plugged in and the drive is powered up. The HOA keypad will display the time and date setup screen for 30 seconds. If a button is not pressed during this time, the display will clear and a “Clock Not Set” alarm will flash. Pressing the F2 (Data) key will display the setting screen again.

■ Feedback Loss Wire Break Alarm

If there is no sensor wired to the drive, a “Feedback Loss – Wire Break” alarm will flash on the display. Providing the proper feedback device signal will clear the Feedback Loss alarm.

The drive requires a feedback device (e.g., pressure transducer, flow meter, etc.) to perform automatic system regulation. Any analog 0~10 V or 4~20 mA feedback device can be used in combination with the drive.

Note: The factory default setting for the drive is 4~20 mA feedback device connected to analog input A2.

■ Real Time Clock Setting Display

Note: Setting the Real-Time Clock will clear a “Clock Not Set” alarm.

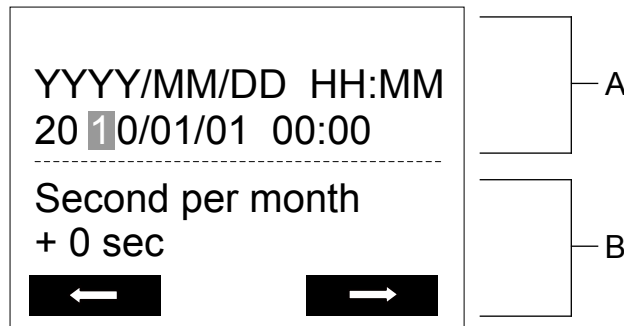

A – Real Time Clock Setting Display
Set in 24-Hour Clock Time

B – Gain/Loss Adjustment Display

Figure 4.1 Real Time Clock Adjustment Display

Display	Description
YYYY	Set the year with the last two digits.
MM	Set the month with two digits.
DD	Set the day with two digits.
HH:MM	Set the hours and minutes, with two digits for each. Note: Set in 24-hour clock time. After initial setup, the time will display in 12-hour clock time.
Second per month	Set the gain or loss in seconds per month. Note: This does not need to be set for the RTC to function properly.

Moving the Cursor

Pressing the F2 key or the RESET key will move the cursor to the digit on the right. Pressing the F1 key will move the cursor to the left.

Changing Settings

- **Changing YYYY/MM/DD HH:MM:** Pressing the up arrow key will increase the number selected by the cursor from 0 to 9. Pressing the down arrow key will decrease the number selected by the cursor from 0 to 9.
- **Setting the Seconds per Month:** *This setting does not need to be adjusted.* Pressing the up arrow key will increase the number selected by the cursor from -504 to +488 in increments of 8. Pressing the down arrow key will decrease the number selected by the cursor from -504 to +488 in increments of 8.

The feature is used to keep the RTC in sync with an external device clock, like a PLC or BAS system, and will adjust the clock by a set amount of seconds every month.

Real-Time Clock Setting at Initial Power-up of a New Drive

Setting the Real-time clock is required at power-up of a new HOA operator or after digital operator battery replacement.

Table 4.1 illustrates how to set the Real-Time Clock at initial power-up of a new drive.

Table 4.1 Clock Adjustment Procedure at Power-up of a New Drive

Procedure		Display
1	Turn the power on. The Real Time Clock Adjustment Display will appear. Use the right arrow key to select the desired digit, then set the correct date and 24-hour clock time using the up and down arrow keys.	<p>ALM YYYY/MM/DD HH:MM 20 10/01/01 00:00 ----- Second per month + 0 sec ← →</p>
2	After entering the Real-Time Clock data, press the ENTER key to save the changes. The display will indicate “Entry Accepted” and return to the initial display in step 3 and the alarm LED will be OFF.	<p>ALM Entry accepted</p>
3	Initial display.	<p>- MODE - DRV Rdy Auto Setpoint U5-99= 0.0PSI ----- U1-02= 0.00Hz [LSEQ] U1-91= 0.0PSI [LREF] <-MONITOR-></p>

Manual Clock Adjustment by Setting o4-17 to 1

The following actions are possible in the Clock Adjustment Mode:

- Set the current time
- Check the time set to the drive Real-Time Clock

Table 4.2 illustrates how to set the Real-Time Clock manually.

Table 4.2 Manual Clock Adjustment Procedure by Setting o4-17 to 1

Procedure		Display
1	The “Clock Not Set” display will appear if the Real-Time Clock data is not entered within 30 seconds of power-up of a drive with an HOA operator that has not yet been set.	<p>ALM - MODE - DRV Rdy Clock Not Set Press F2 to Set FWD DATA</p>
2	Use the up and down arrow keys to scroll through display menu until the screen shows “Programming”.	<p>ALM - MODE - PRG Programming HOME FWD</p>

4.2 Powering Up the Drive

Procedure		Display
3	Press the ENTER key to enter select the parameter setting mode.	
4	Use the up and down arrow keys to scroll through display menu until parameter o4-17 appears.	
5	Press the ENTER key until "0" flashes.	
6	Press the up arrow key so that the display changes to "1".	
7	Press the ENTER key and the time setting screen will appear. Use the right arrow key to select the desired digit, then set the correct date and time using the up and down arrow keys.	
8	After entering the correct time, press the ENTER key to save the changes. The display will return to the display shown in step 5 and the alarm LED will be OFF.	

■ o4-17: Real-Time Clock Setting (Resetting RTC to Factory Default)

No. (Addr. Hex)	Name	Description	Values
o4-17 (3100)	Set/Reset Real-time Clock	Sets the current date and time for the Real-Time Clock. 0: — — No Setting 1: Real-Time Clock Set 2: Real-Time Clock Reset	Default: 0 Range: 0 to 2

Setting 0: — —

No Setting (Default)

Setting 1: Set

The digital operator will show the Clock Adjustment display. In Clock Adjustment Mode the user can adjust the Real-Time Clock.

Setting 2: Reset

The Real-Time Clock data is cleared. A Clock Not Set alarm will occur until o4-17 is set to 1 and the Real-Time Clock is set.

4.3 Application Selection

Application Presets are available to facilitate drive setup for commonly used applications. Selecting one of these Application Presets automatically assigns functions to the input and output terminals and sets a predefined group of parameters to values appropriate for the selected application.

In addition, the parameters most likely to be changed are assigned to the group of User Parameters, A2-01 through A2-16. User Parameters are part of the Setup Group, which provides quicker access by eliminating the need to scroll through multiple menus.

Note: Entering a value to A1-03 to enable an Application Preset will fix that value to the parameter. The value cannot be changed without first setting A1-03 to 2220 or 3330 to initialize the drive.

WARNING! Sudden Movement Hazard. Confirm the drive I/O signals and external sequence before performing a test run. Setting parameter A1-03 may automatically change the I/O terminal function from the default setting. Failure to comply may result in death or serious injury.

No.	Parameter Name	Settings	Default
A1-03	Initialize Parameters	0: No initialization (default) 1110: User initialize (parameter values must be stored using parameter o2-03) 2220: 2-Wire initialize 3330: 3-Wire initialize 5550: Terminal/Control initialize 6008: Pressure control 6009: Pump down level 6011: VTC pressure control 6012: Pivot Panel VTC 6013: Advanced Pressure Control 6014: Pivot Panel Submersible 7770: General purpose 7771: Submersible motor control	0
A1-06	Application Presets (monitor only)	0: Pressure Control 1: General Purpose 2: Sub Mtr GP Oper 5: General Ext HOA 6: General HOA Keys 8: Pressure Control 9: Pump Down Level 11: VTC Pressure Control 12: Pivot Panel VTC 13: Advanced Pressure Control 14: Pivot Panel Submersible	0

4.4 Using the HOA Keypad

Use the HOA keypad to enter OFF commands, switch AUTO or HAND Mode, change parameters, and display data including fault and alarm information.

◆ HOA Keypad Keys and Displays

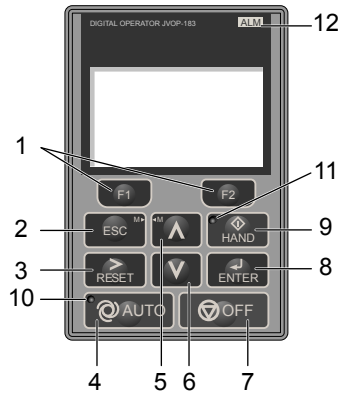

Figure 4.2 Keys and Displays on the HOA Keypad

No.	Display	Name	Function
1		Function Key (F1, F2)	The functions assigned to F1 and F2 vary depending on the currently displayed menu. The name of each function appears in the lower half of the display window.
2		ESC Key	<ul style="list-style-type: none"> Returns to the previous display. Moves the cursor one space to the left. Pressing and holding this button will return to the Frequency Reference display.
3		RESET Key	<ul style="list-style-type: none"> Moves the cursor to the right. Resets the drive to clear a fault situation.
4		AUTO Key	Selects the source of Run command and frequency reference. <ul style="list-style-type: none"> Set the drive to AUTO mode. Run command input source depends on b1-02. Frequency reference input source depends on b1-01.
5		Up Arrow Key	Scrolls up to display the next item, selects parameter numbers, and increments setting values.
6		Down Arrow Key	Scrolls down to display the previous item, selects parameter numbers, and decrements setting values.
7		OFF Key	Follows the stopping method set in b1-03 to stop drive operation.
8		ENTER Key	<ul style="list-style-type: none"> Enters parameter values and settings. Selects a menu item to move between displays.
9		HAND Key	The drive runs at a selectable frequency reference source as set by P5-01. <ul style="list-style-type: none"> Set the drive to HAND mode. When P5-03 is set to 1, HAND and AUTO mode can be switched while the drive is running.
10		AUTO Light	Lit while the drive is in AUTO mode. Refer to page 120 for details.
11		HAND Light	Lit while the drive is in HAND mode. Refer to page 120 for details.
12		ALM LED Light	<i>Refer to ALARM (ALM) LED Displays on page 120.</i>

◆ LCD Display

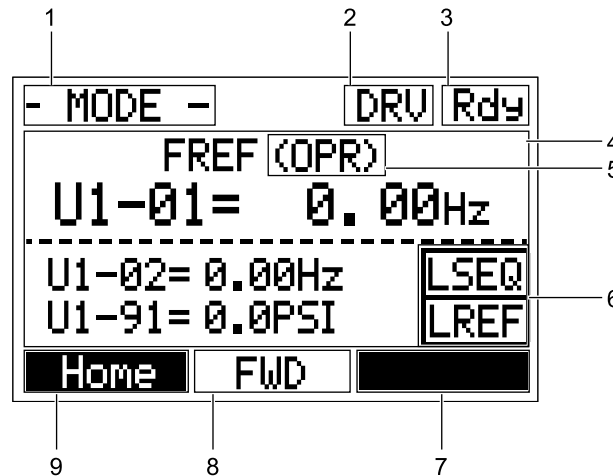







Figure 4.3 LCD Display

Table 4.3 Display and Contents

No.	Name	Display	Content
1	Operation Mode Menus	MODE	Displayed when in Mode Selection.
		QMONI: Use F1/F2	Instructions to access the Quick Monitors.
		MENU: Use UP/DWN	Instructions to access the next menu item.
		MONITR	Displayed when in Monitor Mode.
		VERIFY	Indicates the Verify Menu.
		PRMSET	Displayed when in Parameter Setting Mode.
		A.TUNE	Displayed during Auto-Tuning.
2	Mode Display Area	DRV	Displayed when in Drive Mode.
		PRG	Displayed when in Programming Mode.
3	Ready	Rdy	Indicates the drive is ready to run.
4	Data Display	—	Displays specific data and operation data.
5	Frequency Reference Assignment <F2>	OPR	Displayed when the frequency reference is assigned to the HOA keypad.
		COM	Displayed when the frequency reference is assigned to the MEMOBUS/Modbus Communication Inputs of the drive.
		OP	Displayed when the frequency reference is assigned to option card connected to the drive.
		AI	Displayed when the function reference is assigned to an analog input.
		OFF	Displayed when HAND mode is OFF.
6	LOCAL/REMOTE Display <F2>	RSEQ	Displayed when the Run command is supplied from a remote source. Note: This display will blink when b1-02 is set to 1 (Digital Inputs).
		LSEQ	Displayed when the Run command is supplied from the HOA keypad.
		RREF	Displayed when the Run command is supplied from a remote source. Note: This display will blink when b1-01 is set to 1 (Analog Inputs).
		LREF	Displayed when the Run command is supplied from the HOA keypad.
7	Function Key 2 (F2)	<-MONITOR->	Pressing F2 displays the next Quick Monitor.
		DATA	Pressing F2 scrolls to the next display.
		→	Pressing F2 scrolls the cursor to the right.
		RESET	Pressing F2 resets the existing drive fault error.
		Monitor	Pressing F2 switches Monitor mode.

4.4 Using the HOA Keypad

No.	Name	Display	Content
8	FWD/REV	FWD	Indicates forward motor operation.
		REV	Indicates reverse motor operation.
9	Function Key 1 (F1)	<-MONITOR->	Pressing  displays the next Quick Monitor.
		←	Pressing  scrolls the cursor to the left.
		Home	Pressing  returns to the top menu (Frequency Reference).
		ESC	Pressing  returns to the previous display.
		Monitor	Pressing  switches Monitor mode.

<1> Displayed when in Frequency Reference Mode.

<2> Displayed when in Frequency Reference Mode and Monitor Mode.





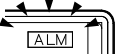
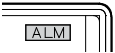









◆ ALARM (ALM) LED Displays

Table 4.4 ALARM (ALM) LED Status and Contents

State	Content	Display
Illuminated	When the drive detects an alarm or error.	
Flashing	<ul style="list-style-type: none"> When an alarm occurs. When an oPE is detected. When a fault or error occurs during Auto-Tuning. 	
Off	Normal operation (no fault or alarm).	

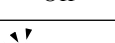
◆ AUTO LED and HAND LED Indications

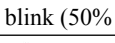
Table 4.5 AUTO LED and HAND LED Indications

AUTO LED	HAND LED	State
 Off	 Off	OFF mode
 Off	 On solid	HAND mode (Also during DC injection braking)
 Off	 Long blink (50% duty)	HAND mode when the Frequency Reference is 0 and/or decelerating in HAND mode, or during PI Sleep or Snooze.
 On solid	 Off	Running in AUTO mode (Also during DC injection braking)
 Off	 Double blink	HAND mode, cycle the Run command.
 Long blink (50% duty)	 Off	Running in AUTO mode when the Frequency Reference is 0 and/or decelerating in AUTO mode, or during PI Sleep or Snooze. AUTO mode, Ready, No Run command input.
 Double blink	 Off	AUTO mode, stopped by a Fast- Stop from a Multi-Function Digital Input.

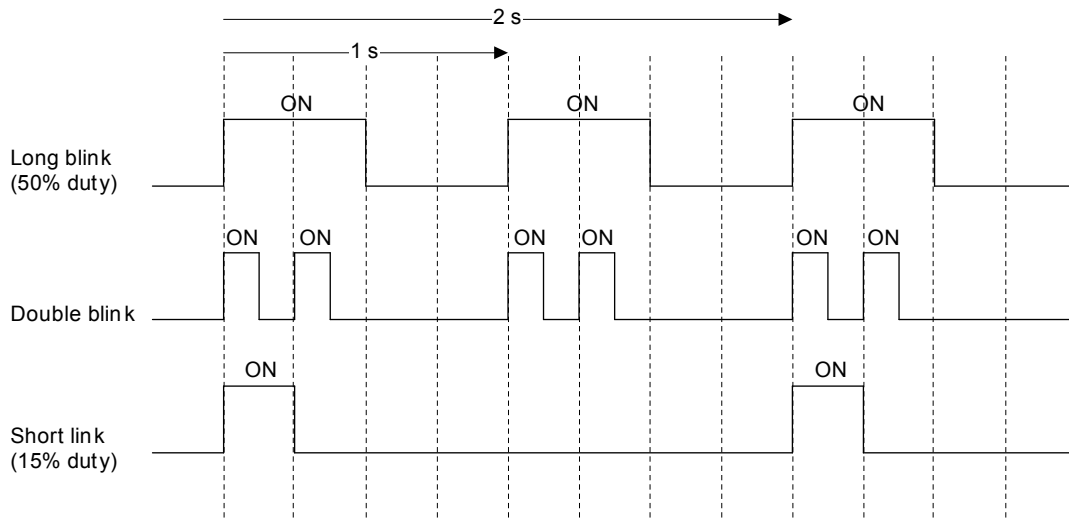

Figure 4.4 AUTO LED and HAND LED Timing Status

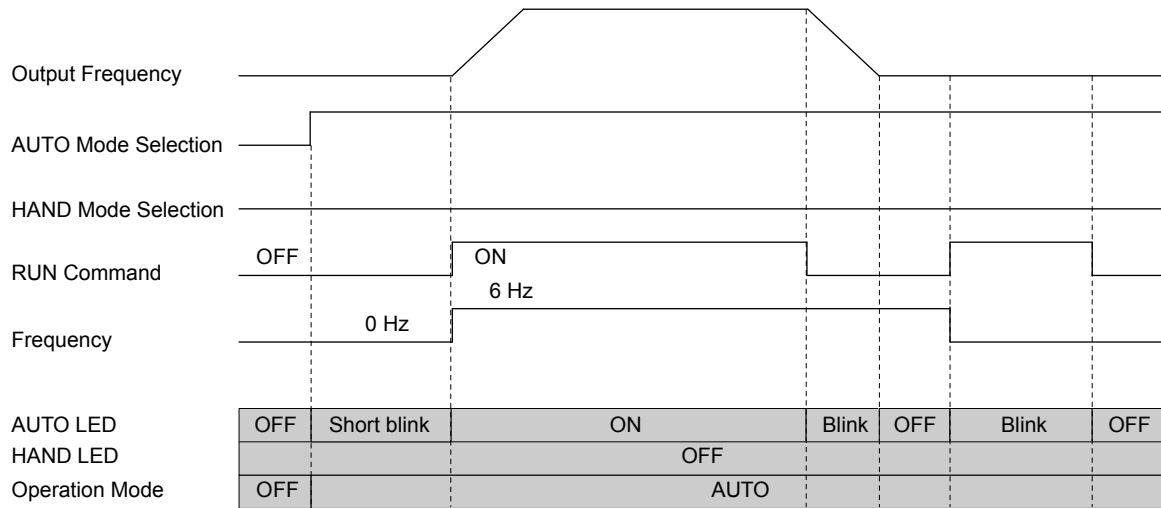

Figure 4.5 LEDs and Drive Operation in AUTO and HAND Modes

◆ Menu Structure for HOA Keypad

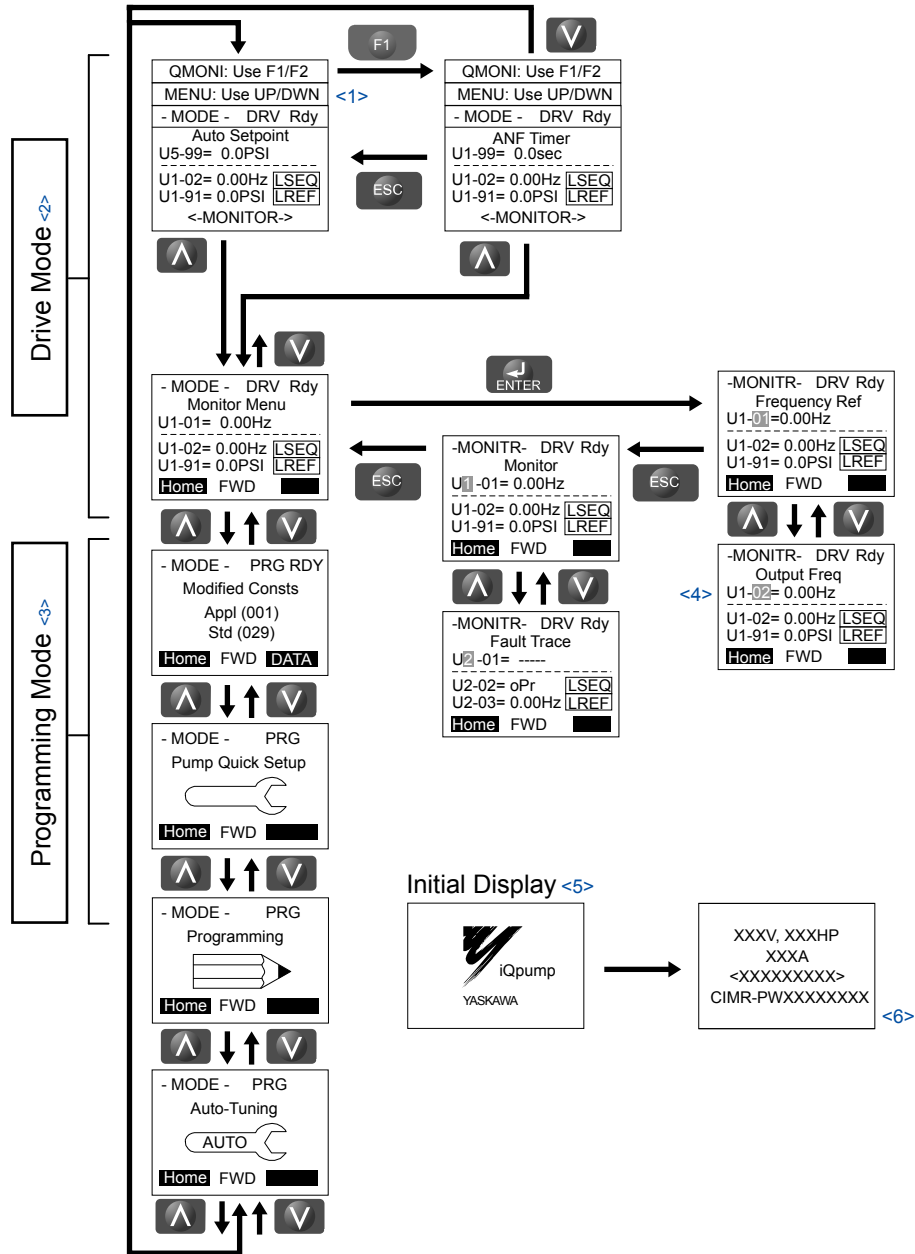

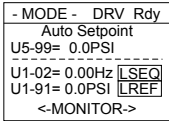

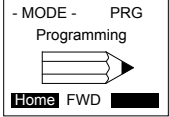

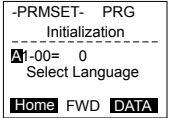

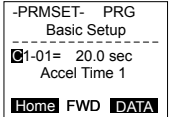

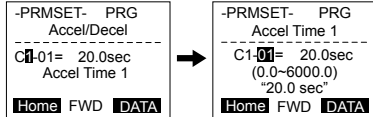

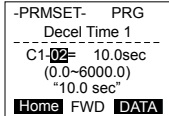

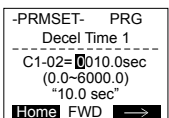

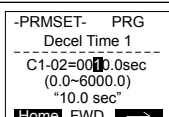

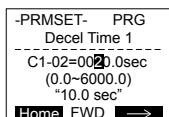

Figure 4.6 HOA Keypad Menu and Screen Structure

- <1> The display cycles between these three displays on the initial startup screen and the Quick Monitor screens.
- <2> Pressing “AUTO” or “HAND” will start the motor.
- <3> Drive cannot operate motor.
- <4> Flashing characters are shown with white letters on gray background. (Example: **0**)
- <5> The Frequency Reference appears after the initial display that shows the product name.
- <6> The information that appears on the display will vary depending on the drive model.

◆ Changing Parameter Settings or Values

This example explains changing C1-02 (Deceleration Time 1) from 10.0 seconds (default) to 20.0 seconds.

Note: During serial communication writing, if a parameter change is also attempted via the HOA keypad, a “BUSY - WRITE PROTECTED” message will display. Parameter change will not be possible from the HOA keypad until an Enter command is received via the serial communication to finish the serial writing process.

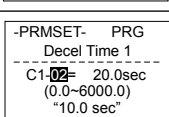
	Step		Display/Result
1.	Turn on the power to the drive. The initial display appears.	→	
2.	Press  or  until the Parameter Setting Mode screen appears.	→	
3.	Press  to enter the parameter menu tree.	→	
4.	Press  or  to select the C parameter group.	→	
5.	Press  two times.	→	
6.	Press  or  to select parameter C1-02.	→	
7.	Press  to view the current setting value (10.0 s). The leftmost digit flashes.	→	
8.	Press  or  until the desired number is selected. “1” flashes.	→	
9.	Press  and enter 0020.0.	→	
10.	Press  to confirm the change.	→	
11.	The display automatically returns to the screen shown in Step 6.	→	

4.4 Using the HOA Keypad

	Step		Display/Result
12.	Press  as many times as necessary to return to the initial display.	→	<pre>- MODE - DRV Rdy Auto Setpoint U5-99= 0.0PSI ----- U1-02= 0.00Hz [LSEQ] U1-91= 0.0PSI [LREF] <-MONITOR-></pre>

4.5 Pump Application Presets

The following sections list the parameters affected by the different Application Presets.

Note: Setting A1-03 to 6011 or 6012 changes the Quick Start and Preset parameters (tables below) and also changes HAND Mode so that it is no longer lower-limited by the minimum pump frequency or the thrust frequency. Also, the default for P1-06 when in RPM mode is 1800 RPM instead of 2400 RPM.

◆ Modified Parameters Depending on A1-03 Setting

The following tables show the parameters that are set depending on the A1-03 initialization:

A1-03 = 6008 (A1-06 = 8) Pressure Control		A1-03 = 6009 (A1-06 = 9) Pump Down Level		A1-03 = 6011 (A1-06 = 11) VTC Pressure Control		A1-03 = 6012 (A1-06 = 12) Pivot Panel VTC	
Parameter	Value	Parameter	Value	Parameter	Value	Parameter	Value
A1-02	0	A1-02	0	A1-02	0	A1-02	0
		b5-09	1	b1-03	1	b1-02	1
		b5-39	2	b5-03	5.0	b1-03	0
		P1-02	6	C1-01	15.0 s	b5-03	5.0 s
		P2-01	2	C1-02	15.0 s	C1-01	20.0 s
		P2-23	0.00%	E1-04	65.0 Hz	C1-02	20.0 s
				E2-04	4	E1-04	65.0 Hz
				L2-01	0	E2-04	4
				L5-01	0	L2-01	0
				P1-03	100.0 PSI	L5-01	0
				P1-06	35.0 Hz	L5-04	300.0 s
				P2-03	15 s	P1-03	200.0 PSI
				P2-23	0.00%	P1-06	35.0 Hz
				P3-50	35.0 Hz	P1-11	210.0 PSI
				P3-60	35.0 Hz	P1-40	60.0 Hz
				P3-70	35.0 Hz	P2-03	15 s
				P4-12	0.0 Hz	P2-23	0.00%
				P5-02	6.0 Hz	P4-12	0.0 Hz
				Q5-03	40.0 PSI	P5-01	0
				Q5-06	50.0 PSI	P5-02	6.0 Hz
				Q5-09	20.0 PSI		
				Q5-10	5.0 min		
				Q5-11	2		
				Q5-16	1.00		
				Q5-17	3.0 s		
				H2-01	80H		
				H2-02	81H		
				H2-03	82H		
				P1-40	60.0 Hz		
				P3-01	2		
				P3-04	5.0 PSI		
				P3-06	5.0 Hz		
				P3-07	7.0 s		
				P3-10	2.0 PSI		

4.5 Pump Application Presets

A1-03 = 6013 (A1-06 = 13) Advanced Pressure Control		A1-03 = 6014 (A1-06 = 14) Pivot Panel Submersible		A1-03 = 7770 (A1-06 = 1) General Purpose		A1-03 = 7771 (A1-06 = 2) Sub Mtr GP Oper	
Parameter	Value	Parameter	Value	Parameter	Value	Parameter	Value
A1-02	0	A1-02	0	A1-02	0	A1-02	0
		b1-02	1	b1-01	1	b5-01	0
		b1-03	0	b1-02	1	H1-06	4
		b5-03	5.0 s	b5-01	0	H2-01	0
		C1-01	20.0 s	C1-01	25.0 s	H2-02	A
		C1-02	20.0 s	C1-02	25.0 s	o1-06	0
		E1-04	65.0 Hz	H1-06	4	P1-05	0 s
		L2-01	0	H1-07	F	d1-01	40.00 Hz
		L5-01	0	H2-01	0		
		L5-04	300.0 s	H2-02	A		
		P1-03	200.0 PSI	H3-10	2		
		P1-11	210.0 PSI	L5-01	0		
		P1-40	60.0 Hz	L5-04	180.0 s		
		P2-03	15 s	o1-06	0		
		P2-23	0.00%	P1-05	0 sec		
		P5-01	0	P1-06	0.0 Hz		
		P5-02	6.0 Hz	P4-12	0.0 Hz		
				P4-17	0.0 min		
				P5-02	0.0 Hz		

◆ Pump Quick Setup Menu Depending on A1-06 Setting

The following table shows which parameters are shown on the Pump Quick Setting menu depending on the A1-06 selection:

A1-03 = 6008 (A1-06 = 8) Pressure Control	A1-03 = 6009 (A1-06 = 9) Pump Down Level	A1-03 = 6011 (A1-06 = 11) VTC Pressure Ctl	A1-03 = 6012 (A1-06 = 12) Pivot Panel VTC	A1-03 = 6013 (A1-06 = 13) Adv PressureCtrl	A1-03 = 6014 (A1-06 = 14) Pivot Panel Submersible	A1-03 = 7770 (A1-06 = 1) General Purpose	A1-03 = 7771 (A1-06 = 2) Sub Mtr GP Oper
E2-01	E2-01	E2-01	E2-01	E2-01	E2-01	b1-01	E2-01
E2-04	E2-04	b1-02	b1-02	E2-20	b1-02	b1-02	E2-04
P1-03	P1-02	b1-03	b1-03	P1-03	b1-03	C1-01	d1-01
Q1-01	P1-03	b1-11	b1-11	Q1-01	b1-11	C1-02	P1-06
P1-04	Q1-01	C1-01	C1-01	P1-04	C1-01	E2-01	P4-10
P1-06	P1-04	C1-02	C1-02	P1-06	C1-02	E2-04	P5-04
P4-10	P1-06	P1-03	P1-03	P1-08	P1-03	L5-01	
P5-04	P2-02	Q1-01	Q1-01	P1-09	Q1-01	L5-04	
	P4-10	P1-04	P1-06	L5-40	P1-06	P1-06	
	P5-04	P1-06	P1-08	P1-11	P1-08		
		P1-08	P1-09	P1-12	P1-09		
		P1-09	P1-11	L5-41	P1-11		
		P1-11	P1-12	P1-15	P1-12		
		P1-12	P4-01	P1-16	P4-01		
		P2-02	P4-02	L5-50	P4-02		
		P2-03	P4-03	P1-19	P4-03		
		P4-01	Q3-01	P1-20	Q3-01		
		P4-02	Q3-02	P1-23	Q3-02		
		P4-03		L5-51			
		Q3-01		P5-04			
		Q3-02		P4-10			

4.6 U1000 iQpump Presets and Functions

◆ Pump Down Level Control Application Preset

This preset allows the drive to regulate the depth of water in a tank or other vessel that is being filled by an external source. A feedback device that measures water depth is wired to the drive. A PI-control process loop will then modulate the pump speed to pump water out the tank to keep the water depth the setpoint level (pump out at the recharge rate). The drive controller has an application preset to simplify the start up and control of this application.

- System units are in feet (P1-02 = 6).
- Feedback device scaling (P1-03). The feedback device scaling must be entered into the drive for proper control.
- Minimum pump speed (P1-06). Most pumps cannot be run below a certain speed or cavitation can occur.
- Number of Motor Poles (E2-02). The default is for a 2-pole motor.
- Sleep Function. The drive controller will sleep when the system demand is low and awaken when demand returns.

■ Required Control Wiring

Most depth level transducers have current-based feedback (4-20 mA). The A2 terminal of the drive is preset for 4-20 mA and preprogrammed for PI feedback (H3-10 = B). If the sensor is voltage based (0-10 V) and terminal A3 is unused, then wire the transducer to terminal A3 and program H3-10 to F (A2 not used) and H3-06 to B (A3 PI Feedback).

■ Start Up Procedure

1. Set parameter A1-03 to 6009 (Pump Down Level) to preset parameter values for this application.
2. Set the motor-rated current in parameter E2-01. This information can be found on the motor nameplate or specification sheet.
3. Set the number of motor poles in parameter E2-04 (2-pole motors have a rated RPM of slightly less than 3600 RPM; 4-pole motors have a rated RPM of slightly less than 1800 RPM). This information can be found on the motor nameplate or specification sheet.
4. Set the feedback device scaling in parameter P1-03. Check the sensor nameplate or specification sheet. For example, if the device outputs 20 mA at 14.50 ft of water depth, the set P1-03 to 14.50. The drive controller will automatically scale all associated parameters and monitors. Monitor U1-91 (Pump Feedback) will display the measured water depth in feet. The drive has a High Feedback Fault set in parameter P1-11. Make sure that P1-11 is appropriately set for sensor scaling in P1-03.
5. Set the desired water depth level in parameter Q1-01 (PI setpoint). This is desired water depth that the drive will regulate the pump speed around. To quickly access this parameter, press the F1 key and then the ENTER key. The U1-99 monitor on the home screen displays the Q1-01 PI setpoint.
6. Set parameter P1-04 Start/Draw Down Level PSI value. It is mandatory to program the Start / Draw Down Level in order to use the sleep function. When the iQpump is turned ON and the feedback signal level (transducer) falls below the P1-04 PSI set value, the pump system will wake from sleep and start after the time specified in P1-05 (default 1 sec). The P1-04 PSI value can be set as either an Absolute level or Delta level from the setpoint.

Absolute Level Example: A Start /Draw Down Level P1-04 set to 50 PSI and delay time P1-05 set to 5 sec. The pump system will start when the pressure drops below 50 PSI for 5 sec.

7. Set the minimum speed that the pump can be run in parameter P1-06. The default is 40 Hz. This information can be found on the pump specification sheet.
8. The default settings will allow the drive to automatically restart after power loss if the drive was running at the time of power loss. To disable, set P4-10 to 1.
9. Press the AUTO key to start the drive with PI control (water depth control). Press the OFF key to stop the drive.
10. The pump can be run in a Hand (local) mode for maintenance purposes by pressing the HAND key while the drive is stopped. The HAND key acts as a start button. Press the OFF button to stop the drive. Press AUTO to return the drive to PI control. The HAND speed reference can be set in P5-02 (Hand Reference 1). Disable the HAND key by setting P5-04 to 0 (disabled).
11. Configure the sleep function. The pump can be programmed to shut off or “sleep” if the water falls below the depth set in parameter P2-02 (Sleep Level). The controller will monitor the water depth feedback signal and wake up when the water depth rises above the setting in parameter P1-04 (Start – Draw Down Level). Logically, set the Sleep Level (P2-02) lower than the PI setpoint and set the Draw Down Level (P1-04) slightly above the PI setpoint. This way the drive won't wake up until the water has already exceeded the desired depth setting. By sleeping, the drive will save energy and mechanical wear. A setting of zero in P1-04 will disable the sleep function (default setting).

■ Related Parameters

No.	Parameter Name	Setting Values
A1-01	Access Level Selection	Default: 2 Range: 0 to 3
A1-03	Initialize Parameters	Default: 0 Range: 0 to 5550; 6008 to 6014; 7770, 7771
E2-01	Motor Rated Current	Default: Minimum: 10% of drive rated current Maximum: 200% of drive rated current
E2-04	Number of Motor Poles	Default: 2 Minimum: 2 Maximum: 48
P1-03	Feedback Device Scaling	Default: 145.0 PSI Minimum: 0.1 Maximum: 6000.0
P1-11	High Feedback Level	Default: 0.0 PSI Minimum: 0.0 Maximum: 6000.0 <1>
P1-06	Minimum Pump Speed	Default: 40.0 Hz Minimum: 0.0 Maximum: [E1-04]
P1-04	Start / Draw Down Level	Default: 0.0 Minimum: -999.9 Maximum: 999.9
P2-02	Sleep Level	Default: 0.0 Hz Minimum: 0.0 Maximum: 6000.0
P4-10	AUTO Mode Operator Run Power Down Storage	Default: 0 Range: 0, 1
P5-02	HAND Speed Reference 1	Default: 40.0 Hz Minimum: 0 Maximum: [E1-04]
P5-04	HAND Key Function Selection	Default: 1 Range: 0, 1
Q1-01	PID Controller Setpoint 1	Default: 0.0 Minimum: 0.0 Maximum: 6000.0
U1-99	Anti-No-Flow Timer	No signal output available

<1> Range is 0.0 to 999.9 with sign-bit “-” indicating Delta to Setpoint.

◆ Suction Control via Constant Pressure w/Well Draw Down

This function enables the iQpump Controller to monitor suction pressure at the inlet of the pumps.

Note: This function is active when parameter Q5-01 is set to 1 for Suction Control.

Packaged Booster Systems have a desired discharge pressure and a given suction pressure from the city water system or from a suction tank. Such systems are often designed to handle a specific pressure and flow rate.

The suction pressure may have a wide range between high and low pressures. The suction pressure typically decreases with increased fluid flow rate. In some instances, pump cavitation may occur if suction pressure falls below a certain pressure level.

In addition, low or negative suction pressure can lead to damage such as pipe collapse due to external forces acting on the pipe.

The iQpump Controller will accept an analog suction transducer (Terminal A1) and can be programmed to trigger an alarm or shutdown the system when the suction pressure falls outside of a normal operating range. The iQpump Controller will automatically restart and return to normal operation once the suction pressure returns to a normal level.

When operating in multiplex mode, additional control can be programmed to de-stage any active pumps as a method to try and reduce pump loading to prevent suction pressure from continuing to drop below the shut down level.

■ Function Description

The iQpump Controller will regulate outlet pressure of the pump system using the standard iQpump Controller features when there is adequate suction pressure available at the inlet of the pumps and offers two options to respond to a drop in suction pressure.

1. Regulate Outlet Pressure and Suction Pressure: $Q5-03 \geq Q5-04$

To regulate suction pressure set the suction pressure setpoint (Q5-03) to a value greater or equal than the minimum suction pressure (Q5-04). In this mode the iQpump Controller will try to regulate the suction pressure based on the programmed suction pressure setpoint (Q5-03) level.

As the suction pressure decreases and approaches the suction pressure setpoint level (Q5-03), the iQpump Controller will slow down causing the outlet pressure and flow to decrease. When the suction pressure rises above the Q5-06 level for longer than the Q5-07 time, normal operation (outlet pressure regulation) will resume.

The iQpump controller goes to sleep when the suction pressure drops below Minimum Suction Pressure (Q5-04), for longer than the Sleep Delay Time (Q5-05).

Note: The Suction Control Minimum Speed parameter (Q5-08) should be set to a high enough value that will ensure flow.

2. Regulate Outlet Pressure Only: $(Q5-03 < Q5-04)$

Set the suction pressure setpoint (Q5-03) to a value smaller than the minimum suction pressure (Q5-04) to regulate outlet pressure.

This mode allows the iQpump Controller to maintain the outlet pressure setpoint using the standard iQpump Controller features and go to sleep immediately when the suction pressure drops below the Minimum Suction Pressure (Q5-04), for more than the Sleep Delay Time (Q5-05).

Normal operation (outlet pressure regulation) resumes when the suction pressure rises above the Q5-06 level for longer than the Q5-07 time.

■ Enabling Suction Pressure Control

The suction pressure control selection is added to parameter Q5-01 Water Level/Suction Pressure Selection. Follow the steps below for basic suction pressure control setup:

1. Enable suction control by setting parameter Q5-01 to 1 (Suction Control).
2. Set suction transducer scaling (Q5-02) in psi, scaling for analog input A1 (20 mA scale).
3. Set suction pressure setpoint (Q5-03) in psi.
4. Select iQpump operation when a drop in suction pressure occurs:

Regulate outlet pressure only and go to sleep immediately when suction pressure falls below minimum suction pressure level (Q5-04). Set suction pressure setpoint (Q5-03) below minimum suction pressure level (Q5-04).

Regulate suction pressure when pressure is below suction pressure setpoint (Q5-03) but above the minimum suction pressure level (Q5-04). Set suction pressure setpoint (Q5-03) to above the minimum suction pressure level (Q5-04).

5. Set minimum suction pressure (Q5-04) – Sleep Level for Suction Control.
6. Set suction pressure wake-up level (Q5-06) – Wake-up level.
7. Set suction control minimum speed (Q5-08) – Minimum Flow Speed.

◆ General Purpose Mode Application Preset

The purpose of this mode is to allow the drive controller to run a motor at a set speed without the PI process loop. This preset is designed to simplify using the drive for applications other than pumping control. The default settings call for the frequency reference to be an analog input and the run command to come from the terminal strip via a maintained contact closure. The PI loop is disabled and no process feedback is required.

■ Required Control Wiring

No additional control wiring is required when the drive controller is at its default settings.

■ Start Up Procedure

1. Set parameter A1-03 to 7770 (General Purpose Mode) to preset parameter values for this application.
2. Set the source of the frequency reference for the drive controller in parameter b1-01. The default setting is from the terminal strip via a 0 to 10 V analog signal wired into terminal A1.
3. Set the source of the Run Command for the drive controller in parameter b1-02. The default setting is from the terminal strip via a maintained contact closure.
4. Set the Acceleration Time of the motor in parameter C1-01. This is the time to accelerate the motor from zero speed to 60 Hz (E1-04 Maximum Output Frequency).
5. Determine the stopping method of the motor. The default setting is coast to stop. To ramp the motor to a stop, set b1-03 to 0 and then set the motor deceleration time in parameter C1-02. This is the time to stop the motor from to 60 Hz (E1-04 Maximum Output Frequency) to zero speed.
6. Set the motor-rated current in parameter E2-01. This information can be found on the motor nameplate or specification sheet.
7. Set the number of motor poles in parameter E2-04 (2-pole motors have a rated RPM of slightly less than 3600 RPM; 4-pole motors have a rated RPM of slightly less than 1800 RPM). This information can be found on the motor nameplate or specification sheet.
8. Determine whether the drive controller should attempt to reset itself after a fault. The default setting is disabled. The function is turned on by setting 1 to 10 reset attempts in parameter L5-01 and the time between each reset in parameter L5-04.
9. Set the minimum speed at which the motor can run in parameter P1-06. The default is 0 Hz. If the system has a minimum safe operation speed, set it in P1-06. This will act as a lower limit of the frequency reference.
10. The motor can be run in HAND (LOCAL) Mode for maintenance purposes by pressing the HAND key while the drive is stopped. The HAND key acts as a start button. Press the OFF button to stop the drive. Set P5-04 to 0 to disable the HAND key. The default frequency reference is 0.0 Hz in HAND Mode. This can be changed in parameter P5-02. The AUTO key has no effect with the default settings in the General Purpose Application Preset.

■ Related Parameters

No.	Parameter Name	Setting Values
A1-03	Initialize Parameters	Default: 0 Range: 0 to 5550; 6008, 6009; 6011 to 6014; 7770, 7771
b1-01	Frequency Reference Selection 1	Default: 0 Range: 0 to 5
b1-02	Run Command Selection 1	Default: 0 Range: 0 to 3; 6 to 8
b1-03	Stopping Method Selection	Default: 1 Range: 0 to 3
C1-01	Acceleration Time 1	Default: 20.0 s Minimum: 0.0 Maximum: 6000.0 </>
C1-02	Deceleration Time 1	Default: 20.0 s Minimum: 0.0 Maximum: 6000.0
E1-04	Maximum Output Frequency	Default: 60.0 Hz Minimum: 40.0 Maximum: 400.0

4.6 U1000 iQpump Presets and Functions

No.	Parameter Name	Setting Values
E2-01	Motor Rated Current	Default: Minimum: 10% of drive rated current Maximum: 200% of drive rated current
E2-04	Number of Motor Poles	Default: 2 Minimum: 2 Maximum: 48
L5-01	Number of Auto Restart Attempts	Default: 5 Minimum: 0 Maximum: 10
L5-04	Fault Reset Interval Time	Default: 20.0 s Minimum: 10.0 Maximum: 3600.0
P1-06	Minimum Pump Speed	Default: 40.0 Hz Minimum: 0.0 Maximum: [E1-04]
P5-02	HAND Reference	Default: 40.0 Hz Minimum: 0 Maximum: [E1-04]
P5-04	HAND Key Function Selection	Default: 1 Range: 0, 1

<1> Range is set by C1-10, Accel/Decel Time Setting Units. When C1-10 = 0 (units of 0.01 seconds), the setting range becomes 0.00 to 600.00 seconds.

◆ Well Draw Down Control Application Preset

The Well draw down function allows the drive to deliver water at a constant pressure as long as ground water level remains above a specified level. If the ground water level drops to this specified level the drive will switch from a constant pressure regulator to a level regulator, which will continue to supply water at the recharge rate of the well. Water will continue to flow at a reduced rate. Should the water level down hole continue to drop the drive will go to sleep and wait till the water level rises again to the specified wake up level to start pumping again. Once the water level rises above that level it will switch back to constant pressure mode.

■ Start Up Procedure

The following is a sample setup for the Well Draw Down function with 4 to 20 mA transducer feedback on both level (connected to input A1) and constant pressure (connected to A2)

1. Select a Proper Depth Sensing Transducer. The proper transducer for depth sensing has been specifically designed for depth sensing. This means the transducer element, electrical connections, and connecting cable are sealed for submersion. Additionally the sensor will have a vent tube running the length of the electrical conductors to compensate for changes in barometric air pressure, which ensures accurate feedback with changing weather patterns. Another important design characteristic is that the electrical conductors are installed by the manufacturer at the length specified by the installer. This ensures that the manufacturer can calibrate the transducer to compensate for the voltage drop across the conductor length. The maximum length for pressure transducer leads is 50 meters (164 feet) and beyond that length the voltage drop will cause inaccurate feedback. It is common for wells to exceed this depth. Do not use standard pressure transducer for level control. Select a range of depth that closely matches your application range. One size does not fit all as depth calculations work with small changes in feedback. If the range is too large accuracy will be compromised.

Proper Depth Transducer Characteristics:

Sealed element and electrical connections

Barometric compensation

Specified cable length calibrated by the manufacturer

Proper range, one that is close to applications actual operation

2. Install Depth Sensing Pressure Transducer Down Hole. Since the feedback from the transducer is low voltage and the output of the drive to the motor is a PWM waveform an effort should be made to keep the transducer leads as far from the motor leads as possible. Given that space in the bore hole is at a premium this is a difficult task and connection of the transducer shield drain wire is important. Many installers will set the transducer in its own plastic tubing with a cap at the bottom end that the transducer can rest on. It is necessary to drill holes in the tubing at or close to the bottom to allow water to flood the tube. This type of installation will help protect the transducer and connecting cable from damage and allow it to be retrieved if necessary.
3. Connect Level Transducer to the drive via Terminal A1. Most depth level transducers are current based feedback, typically 4 to 20 mA. The A1 terminal of the drive is selectable for either voltage or current based pressure transducer feedback. Most transducers in common use are current based (4 to 20 mA).
4. Set the drive to accept current based (4 to 20 mA) Feedback Set the A1 terminal of Jumper S1 to current type input (I) as shown in [Figure 4.7](#). Set parameter H3-01 to 2 (4 to 20 mA) for signal type on A1. Set parameter H3-02 to 23, function of the A1 input, Well Level feedback

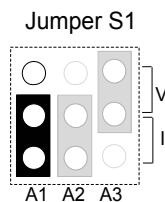

Figure 4.7 Terminal A1 Set to Current Input

Table 4.6 Jumper S1 Settings

Setting	Description
V (top position)	Voltage input (0 to 10 V Bipolar)
I (bottom position)	Current input (4 to 20 mA or 0 to 20 mA)

5. Connect Standard Pressure Transducer to Terminal A2. Terminal A2 is designed to accept both current and voltage based feedback devices and by default the drive is set to 4 to 20 mA input. Make sure to set all necessary parameters for proper constant pressure regulation.

4.6 U1000 iQpump Presets and Functions

6. Set parameter Q4-01 to 1 to enable the Well Draw Down Feature.
7. Set Constant Pressure Setpoint in U1-01 or Q1-01. U1-01 is the only monitor which will change parameter values without going to the program menu. Using this monitor, the setpoint can be changed while the drive is running. A setpoint must be entered for the Well Draw Down feature to work properly.
8. Enter the maximum value of the range of the transducer in PSI in parameter Q4-02 and the drive will automatically scale associated parameters. The level transducer should display a specification for range (e.g., 0 to 50 PSI [115.4 feet]) 1 PSI = 2.308 ft.
9. Set Well Level to be maintained in parameter Q4-03 This is the level (in feet) at which the drive will stop regulating pressure and start maintaining level. If the water level rises above this level, the drive will automatically switch back to pressure regulation.
10. Set Well Level to Sleep in parameter Q4-04 When the well level reaches this level (in feet) and the sleep time set in parameter Q4-05 expires, the drive will go to sleep and stop running the pump. The pump will remain in this state until the well level reaches the wake level set in Q4-06.
11. Set Wake Level in parameter Q4-06. When the well level has reached this level (in feet) and the on-delay timer set in Q4-07 expires, the drive will automatically start running again. Set this level should to a value greater than Q4-03 (Maintain Level) so the drive will automatically go to pressure regulation mode.
12. Set the Minimum Pump Speed while in Level Control in parameter Q4-08 Set this speed at a level which ensures that the pump is moving water out of the well. If it is set to a speed where no water is moving, the PI regulator may not drive the well level to the sleep level and cause damage to the pump or motor. This speed is only used in Level Control Mode but the actual minimum speed in Level Mode will be the greater value between P1-06 (minimum pump frequency) and P4-05 (thrust frequency). If Q4-08 is set higher than P1-06 and P4-05, it will only be used while the drive is in Level Control Mode.
13. Set Low Level Detection Value in Parameter Q4-09 and program the drive response in Q4-11 This is the level (in feet) at which you do not want the pump to run at because below this level there is a danger dry running. Generally this level is a fail safe level and if reached you would likely want the drive to fault out and stop running immediately. This can also activate the drive fault contacts, which can be used for auxiliary notification such as a horn or external warning light. In Q4-11 the drive can be programmed for one of four responses 0. No Response, 1. Alarm Only, 2. Fault 3. Time Delay. Default is Alarm Only. Note: option 3 is controlled by parameters Q4-12 (timer) and L5-01 > 0 (fault auto-restart).
14. Verify Settings and Well Level in Monitor U1-97 By using monitor U1-97 (displayed in feet) without the pump running you should see the well level displayed and can note it down. Then press the Auto button to start the drive in pressure regulation mode. This assumes all other parameters for pressure regulation have been set up prior to this step. Once the setpoint pressure has been reached check U1-97 and note the level. Depending on the recharge rate of the well this value will be lower than the level without the pump running by some amount. This can give you an idea of the well's recharge rate at the current demand. It will give you an idea if the other levels you have set are appropriate. The level should be checked periodically over the season of operation to check level variations related to times of the year.

■ Related Parameters

No.	Parameter Name	Setting Values
H3-01	Terminal A1 Signal Level Selection	Default: 0 Range: 0 to 3
H3-02	Terminal A1 Function Selection	Default: 0 Range: 0 to 32
L5-01	Number of Auto Restart Attempts	Default: 5 Minimum: 0 Maximum: 10
P1-06	Minimum Pump Speed	Default: 40.0 Hz Minimum: 0.0 Maximum: [E1-04]
P4-05	Pre-Charge Loss of Prime Level	Default: 0.0 A Minimum: 0.0 Maximum: 1000.0
Q1-01	PID Controller Setpoint 1	Default: 0.0 Minimum: 0.0 Maximum: 6000.0
Q4-01	Water Level Selection	Default: 0 Range: 0, 1

No.	Parameter Name	Setting Values
Q4-02	Water Level Scaling	Default: 100 PSI Minimum: 5 Maximum: 500
Q4-03	Water Level Setpoint	Default: 20.0 ft Minimum: 0.0 Maximum: 1200.0
Q4-04	Minimum Water Level	Default: 10.0 ft Minimum: 0.0 Maximum: 1200.0
Q4-05	Water Level Sleep Delay Time	Default: 5 s Minimum: 0 Maximum: 3600
Q4-06	Wake-Up Water Level	Default: 30.0 ft Minimum: 0.0 Maximum: 1200.0
Q4-07	Water Level Control Sleep Wake-Up Time	Default: 1 s Minimum: 0 Maximum: 3600
Q4-08	Level Control Minimum Speed	Default: 0.00 Hz Minimum: 0.00 Maximum: 400.00
Q4-09	Low Level Detection Level	Default: 0.0 ft Minimum: 0.0 Maximum: 1200.0
Q4-10	Low Level Detection Time Delay	Default: 0.0 Minimum: 0.0 Maximum: 300.0
Q4-11	Low Level Behavior	Default: 1 Range: 0 to 3
Q4-12	Water Level Control Auto-Restart Time	Default: 5.0 min Minimum: 0.1 Maximum: 6000.0
Q4-15	Low Water Level Detection Time Unit	Default: 0 Range: 0, 1
U1-01	Frequency Reference	10 V: Maximum frequency
U1-97	Water Level	Full scale: 10 V = Q4-02

◆ Low City or Low Suction Inlet Pressure

This function is used with low suction inlet pressure switches on pressure booster systems for buildings that get their main water supply from a municipality. This pressure switch enables and disables the pump system when the inlet supply is at a low demand and when running the pump system in this condition will cause damage.

An inlet pressure switch is wired directly into the drive using one of the digital input terminals. If the pressure switch is active and sufficient pressure is available, the drive system will operate normally. If the pressure switch indicates that incoming pressure is too low, the drive will take the following actions:

- The drive will be forced into a sleep-like state (coast to stop).
- Any drives staged in multiplex mode will immediately coast to stop.
- The selected alarm “Low City Pressure”, “Low Suction Pressure”, or “Low Water In Tank” will be displayed (determined by P4-24).

All drives will restart when sufficient pressure returns.

■ Required Control Wiring

Any one of the multi-function digital inputs (S1 to S8) must be wired and programmed with a low suction inlet pressure switch. The appropriate terminal parameter (H1-□□) must be set to 73 (Low City Pressure). The action of the switch (normally open / normally closed) is set in parameter P4-21.

■ Start Up Procedure

1. Set all other parameters required for the application such as PI control loop, sleep, motor, and I/O parameters.
2. Set one digital input for the low suction inlet pressure switch (H1-□□ = 73). Wire the switch to this terminal.
3. Configure the terminal for a normally open / closed switch type using parameter P4-21.
4. Configure the delay times for activating and removing the alarm in parameters P4-23 and P4-24. This can be used to stop the drive from cycling too frequently if the pressure varies a lot.
5. Select the alarm message that will be displayed when a Low City condition is detected using parameter P4-24. Options include “Low Cty Pressure”, “Low Suction Pres”, and “Low Watr In Tank”.

■ Related Parameters, Faults, and Alarms

No.	Parameter Name	Setting Values
P4-21	Low City Input Select	Default: 1 Range: 0, 1
P4-22	Low City On-Delay Time	Default: 10 s Minimum: 1 Maximum: 1000
P4-23	Low City Off-Delay Time	Default: 5 s Minimum: 0 Maximum: 1000
P4-24	Low City Alarm Text	Default: 0 Range: 0 to 2

H1 Multi-Function Digital Input Settings

H1-□□ Setting	Function	Description
73	Low City Press	Indicates that sufficient or insufficient pressure is present on the inlet to the pump. Used mainly for pressure booster situations.

HOA Keypad Display	Minor Fault Name
Low City Pressure	Low City Pressure
Cause	Possible Solution
Insufficient pressure is present on the inlet to the pump.	<ul style="list-style-type: none"> • Check pressure switch contact for correct operation. • Check control wiring to drive terminal strip from pressure switch contact. • Check to make sure that suction pressure is present by means of a separate measuring device.

HOA Keypad Display	Minor Fault Name
Low Suction Pressure	Low Suction Pressure
Cause	Possible Solution
Insufficient suction pressure is present.	<ul style="list-style-type: none"> • Check pressure switch contact for correct operation. • Check control wiring to drive terminal strip from pressure switch contact. • Check to make sure that suction pressure is present by means of a separate measuring device.

HOA Keypad Display	Minor Fault Name
Low Water in Tank	Low Water in Tank
Cause	Possible Solution
The water level in the tank is too low.	<ul style="list-style-type: none"> • Check pressure switch contact for correct operation. • Check control wiring to drive terminal strip from pressure switch contact. • Check to make sure that suction pressure is present by means of a separate measuring device.

4.6 U1000 iQpump Presets and Functions

◆ Water Level / Suction Pressure Control

This function provides the ability to use the Low and High Level Detection feature of Water Level or Suction Pressure Control without affecting the output speed (drive main PI control).

This function will affect the output speed only when setting Q4-01 > 0 to enable Water Level Control will and setting Q4-20 to 1 to enable Water Level Speed Control.

In all other cases, only Sleep at Minimum Water Level and Level Detection features are usable.

This function will affect the output speed only when setting Q5-01 > 0 to enable Suction Pressure Control will and setting Q5-20 to 1 to enable Suction Pressure Speed Control.

In all other cases, only Sleep at Minimum Suction Pressure and Pressure Detection features are usable.

■ Related Parameters

No.	Parameter Name	Setting Values
Q4-20	Water Level Speed Control	Default: 1 Range: 0, 1
Q5-20	Suction Pressure Speed Control	Default: 1 Range: 0, 1

◆ Delta Data Entry

Delta Data Entry allows the user to set the Low and High Feedback Detection Levels relative to the current setpoint and establish a PI setpoint when PID is not active.

Parameter/Condition	Delta Entry	Absolute Entry	Range Display (Toggles Automatically)
P1-04 Start Draw Down Level PID Direct-acting	-0.0 to -999.9	0.0 to 999.9	(0.0 to 999.9) <- -> “-Sub frm SetPt”
P1-04 Start Draw Down Level PID Inverse-acting	+0.0 to +999.9	0.0 to 999.9	(0.0 to 999.9) <- -> “+Add to SetPt”
P1-08 Low Feedback Level	-0.0 to -999.9	0.0 to 999.9	(0.0 to 999.9) <- -> “-Sub frm SetPt”
P1-11 High Feedback Level	+0.0 to +999.9	0.0 to 999.9	(0.0 to 999.9) <- -> “+Add to SetPt”

The following conditions will change the setpoint in order of priority when the drive is a non-PID mode or when PID is disabled:

The default Setpoint is Q1-01 (Setpoint 1)

1. Setpoints Q1-02 to Q1-04 when Multi-setpoint Digital Inputs are active (H1-□□ = 8D, 8E, 83, 84, or 85)
2. MEMOBUS Setpoint when MEMOBUS PID Setpoint enable bit is set
3. Pulse Input RP when H6-01 = 2 (PID Setpoint)
4. Analog Input when H3-□□ = C (PID Setpoint).

■ Related Parameters

No.	Parameter Name	Setting Values
P1-04	Start / Draw Down Level	Default: 0.0 Range: 0.0 to 999.9
P1-08	Low Feedback Level	Default: 0.0 Range: 0.0 to 999.9
P1-11	High Feedback Level	Default: 155.0 Range: 0.0 to 999.9

◆ Current Limit

This function provides a current limit of the pump (motor). The function is designed to prevent long-term overload conditions of the pump, especially if the motor and drive are oversized compared to the pump. The drive will attempt to limit the output current by reducing the frequency reference. The frequency is reduced using an internal current PI regulator. When the Current Limit function is active, the alarm "Current Limit Foldback" will be displayed on the HOA keypad. This function will only operate correctly when the drive is connected to a variable torque motor load such as a centrifugal pump. More specifically, it will only operate if the load is such that output current increases as output frequency increases (and vice-versa). The current limit function reduces the pump speed to just above the lower value between the minimum pump speed (P1-06) or the minimum output frequency. If PI mode is enabled (b5-01 > 0), a special limit will be applied to the PID integrator when output current limit is active to prevent integrator wind-up.

■ Start Up Procedure

1. Set all other parameters required for the application such as PI control loop, sleep, motor, and I/O parameters
2. Turn on the current limit function by setting Q3-01 to 1 (enabled). The default setting is 0 (disabled).
3. Set the desired current limit in Q3-02. This value should not exceed the motor, pump or drive's ratings. This does not in any way change the motor (oL1) and inverter (oL2) overload functions.
4. If desired, program a multi-function digital output (H2-□□) to 89 (Output Current Limit) to annunciate the alarm.

■ Related Parameters

No.	Parameter Name	Setting Values
Q3-01	Output Current Limit Select	Default: 0 Range: 0, 1
Q3-02	Current Limit	Default: 0.0 A Minimum: 0.0 Maximum: 1000.0

H2 Multi-Function Digital Output Settings		
H2-□□ Setting	Function	Description
89	Output 1 Limit	Closed: Drive output speed is being limited due to the output current limit or the single phase foldback regulator.

The drive displays an alarm on the keypad when the drive is in output current limit.

HOA Keypad Display	Minor Fault Name
Current Limit Foldback	Current Limit Foldback
Cause	Possible Solution
Drive output speed is being limited due to the output current limit.	<ul style="list-style-type: none"> • Reduce the load. • Verify setting of Q3-02. • Change to a larger drive size.

◆ Vertical Turbine Controller (VTC)

Vertical turbine pumps are typically used when water needs to be pumped from deep-water wells or open bodies of water such as rivers, lakes, irrigation canals, lifting stations, and water storage facilities. The VTC Application Preset allows the operator to easily setup control for a wide range of pumping applications. The drive will automatically adjust pump-operating conditions from Simplex (one pump on the drive) to multiple lag pumps as the process variables change. Control can be extended from simple pressure regulation to adding suction and vacuum control as well.

■ Required Control Wiring

Most pressure transducers have current-based feedback (4 - 20 mA). The drive A2 terminal is preset for 4-20 mA and preprogrammed for PI feedback (H3-10 = B). If the sensor is voltage based (0-10 V) and terminal A3 is unused, then wire the transducer to terminal A3 and program H3-10 to F (A2 not used) and H3-06 to B (A3 PI Feedback).

When using lag pumps, the lag pump on/off control must be wired to the drive digital output terminals. The figure below shows the drive with the pressure transducer wired into terminal A2 and 3 lag pumps wired into output relays.

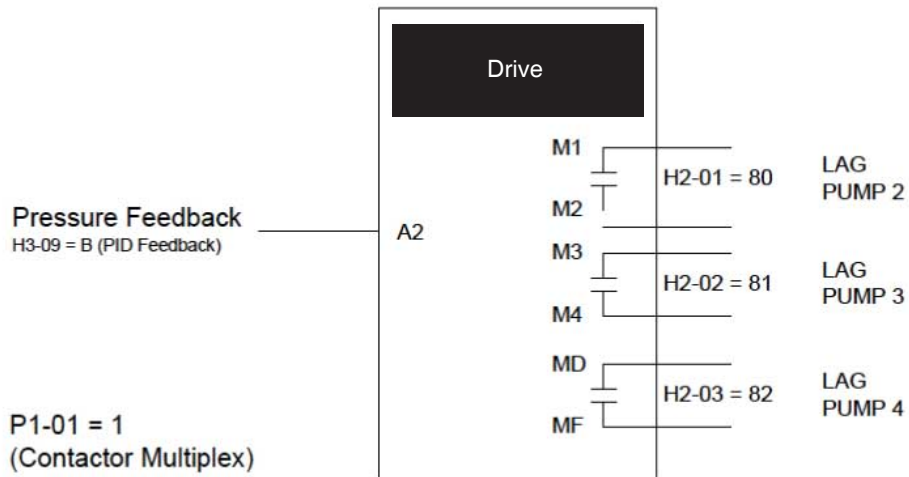

■ Start Up Procedure for Drive with Three Lag Pumps

1. Set parameter A1-03 to 6011 (VTC Pressure Control). This will preset parameter values for this application.
2. Set the motor-rated current in parameter E2-01. This information can be found on the motor nameplate or specification sheet.
3. Set the number of motor poles in parameter E2-04 (2-pole motors have a rated RPM of slightly less than 3600 RPM; 4-pole motors have a rated RPM of slightly less than 1800 RPM). This information can be found on the motor nameplate or specification sheet.
4. Set the feedback device scaling in parameter P1-03. Check the sensor nameplate or specification sheet. For example, if the device outputs 20 mA at 100.0 PSI of pressure, then set P1-03 to 100.0 PSI. The drive controller will automatically scale all associated parameters and monitors. Monitor U1-91 (Pump Feedback) will display the measured pressure in PSI. The drive has a High Feedback Fault set in parameter P1-11. Make sure that P1-11 is appropriately set for sensor scaling in P1-03.
5. Set the desired pressure setpoint in parameter Q1-01 (PI setpoint). This is desired pressure that the drive will regulate the pump to control around. To quickly access this parameter, press the F1 key and then the ENTER key. The U1-99 monitor on the home screen displays the Q1-01 PI setpoint.
6. Set the minimum speed that the pump can be run in parameter P1-06. The default is 35 Hz. This information can be found on the pump specification sheet.
7. The default setting is for the drive to control the pump motor wired to the drive. Additional Lag pumps can be added to the system by wiring the on/off switch of the lag-pump motor to the drive as shown in the figure above. Set parameter P1-01 to 1 (Contactor Lag). This will enable the multiplexing control for multiple pumps
8. Set the number of additional lag pumps in parameter P3-00. For example, for a system with the drive pump and 3 additional lag pumps, set P3-00 to 3.
9. Set each lag pump's shutdown (stage off) level in Parameters P3-50, P3-60 and P3-70. The value is set in Hz. The setting tells the drive controller to de-stage the lag pump if the output frequency drops below this level. This setting needs to be coordinated with minimum pump speed (P1-06) and the sleep level. It is important that all lag pumps be de-staged above the sleep level or the drive will not enter sleep mode

10. The drive will stage lag pumps on based on the output frequency of the drive. At start, only the drive pump will be running. If the drive output frequency reaches 60 Hz for the time set in P3-05 and the pressure setpoint cannot be met, the drive will stage on (turn on) one of the lag pumps. The drive will stage on additional lag pumps until the pressure setpoint can be achieved.
11. The drive will stage lag pumps off based on the output frequency of the drive. Assume the system has been running with multiple lag pumps on. Now the demand starts to drop. The drive's output frequency will drop. If the output frequency falls below a lag pump frequency shutdown level for the time set in P3-09, the pump is de-staged. The drive will continue to de-stage pumps until the pressure setpoint can be met
12. Configure the sleep function. The drive can be programmed to shut off or sleep if the pressure stays at or above the Q1-01 setpoint with all lag pumps de-staged and the drive running at the minimum pump speed. In order to turn on the sleep function, set parameter P1-04 (Start – Draw Down Level) to a level slightly less than the pressure Q1-01 setpoint. When the drive is sleeping and the system pressure drops below the P1-04 setting, the drive will wake up and begin regulating pressure again. By sleeping, the drive will save energy and mechanical wear. A setting of zero in P1-04 will disable the sleep function (default setting).
13. Press the AUTO key to start the drive with PI control (pressure control). Press the OFF key to stop the drive
14. The pump can be run in a Hand (local) mode for maintenance purposes by pressing the HAND key while the drive is stopped. The HAND key acts as a start button. Press the OFF button to stop the drive. Press AUTO to return the drive to PI control. The HAND frequency reference is preset to 6 Hz in parameter P5-02. Disable the HAND key by setting P5-04 = 0 (disabled).

■ Related Parameters

No.	Parameter Name	Setting Values
A1-03	Initialize Parameters	Default: 0 Range: 0 to 5550; 6008 to 6014; 7770, 7771
E2-01	Motor Rated Current	Default: Minimum: 10% of drive rated current Maximum: 200% of drive rated current
E2-04	Number of Motor Poles	Default: 2 Minimum: 2 Maximum: 48
H3-06	Terminal A3 Function Selection	Default: 20 Range: 0 to 32
H3-10	Terminal A2 Function Selection	Default: B Range: 0 to 32
P1-01	Pump Mode	Default: 0 Range: 0, 1
P1-03	Feedback Device Scaling	Default: 145.0 PSI Minimum: 0.1 Maximum: 6000.0
P1-04	Start / Draw Down Level	Default: 0.0 Minimum: -999.9 Maximum: 999.9
P1-06	Minimum Pump Speed	Default: 40.0 Hz Minimum: 0.0 Maximum: [E1-04]
P1-11	High Feedback Level	Default: 0.0 PSI Minimum: 0.0 Maximum: 6000.0
P3-00	Number of Lag Pumps	Default: 1 Minimum: 1 Maximum: 5
P3-05	Add Pump Delay Time	Default: 2 s Minimum: 0 Maximum: 3600
P3-09	Shutdown Pump Delay Time	Default: 5 s Minimum: 0 Maximum: 3600

4.6 U1000 iQpump Presets and Functions

No.	Parameter Name	Setting Values
P3-50	Pump 2 Frequency Shutdown Level	Default: 40.0 Hz Minimum: 0.0 Maximum: 400.0
P3-60	Pump 3 Frequency Shutdown Level	Default: 40.0 Hz Minimum: 0.0 Maximum: 400.0
P3-70	Pump 4 Frequency Shutdown Level	Default: 40.0 Hz Minimum: 0.0 Maximum: 400.0
P5-02	HAND Reference	Default: 40.0 Hz Minimum: 0 Maximum: [E1-04]
P5-04	HAND Key Function Selection	Default: 1 Range: 0, 1
Q1-01	PID Controller Setpoint 1	Default: 0.0 Minimum: 0.0 Maximum: 6000.0
U1-91	Pump Feedback	No signal output available
U1-99	Anti-No-Flow Timer	No signal output available

◆ Pre-Charge Function with One Lag Pump

The pre-charge function is designed to start a pumping system in a controlled manner. Rather than turning on the PI loop immediately at start up, the pre-charge function operates at a fixed speed to pre-fill the piping or storage tank before switching to PID control. This prevents the PI loop integrator from building up unnecessarily and also allows for a soft pressurization and fill of the system.

When an “auto” run command is issued or when waking up from the sleep state, the drive will check to see if it should perform a pre-charge operation. If so, it will ramp up and run at the pre-charge frequency. Some of the pump protective functions are disabled during pre-charge operation.

The drive will exit the pre-charge function when any of the below conditions are met:

- The process feedback level reaches the pre-charge level (P4-01)
- A multi-function digital input programmed for a Low Water Level switch deactivates (H1-□□ = 8F)
- The pre-charge timer expires (P4-03).

■ Required Control Wiring

No control wiring is required. An optional Low Water Level switch can be used to turn off the pre-charge function. Wire the switch into one of the drive digital inputs and program the corresponding H1-□□ parameter to 8F (the switch is normally open and closes during low water level).

■ Start Up Procedure

1. Set all other parameters required for the application such as PI control loop, sleep, motor, and I/O parameters. However, this function can be used in conjunction across a wide range of applications using a PI control process loop.
2. Set the pre-charge level in parameter (P4-01). This is the process feedback level (PSI, depth, etc.) that must be achieved before the pre-charge function will turn off.
3. Set the pre-charge frequency reference in parameter P2-02. This is the frequency that the drive will run at during pre-charge. Set this value to reasonable speed that is above the minimum pump speed (P1-06) and close to the average running frequency of the drive controller.
4. Set the pre-charge timer in P4-03. When the drive goes into pre-charge mode, no low-water switch is wired to the drive, and if the pre-charge level (P4-01) cannot be obtained, the drive will exit the pre-charge function after the P4-03 time and begin normal PI control
5. A multi-function digital input can be wired to and programmed for Pre-charge Disable if required (H1-□□ = 8C). Parameter P1-30 configures the switch type (0: Normally Open, 1: Normally Closed).
6. A multi-function digital output can be wired to and programmed to close whenever the pre-charge function is active (H2-□□ = A4).

■ Conditions for Entering Pre-charge Mode

- Drive Ready or Sleeping (run command, not faulted, not in program mode).
- NOT in HAND Mode
- “Disable Pre-Charge” digital input NOT closed.
- Pre-charge time set greater than zero (P4-03 > 0)
- If the Pre-charge level is greater than zero (P4-01 > 0) and the PID feedback is below the P4-01 level (Forward acting PID, b5-09 = 0).
- If the Pre-charge level is greater than zero (P4-01 > 0) and the PID feedback is above the P4-01 level (Reverse acting PID, b5-09 = 1).

■ Operation During Pre-Charge Mode

- Drive will run at the Pre-Charge frequency (P4-02).
- The PID controller is disabled.
- The HOA keypad will display the message “Pre Chg Mode – Pre-chg Active”.
- The pre-charge digital output (H2-0□ = A4) will close
- If the Pre-Charge frequency (P4-02) is set less than minimum pump speed (P1-06), an alarm “Freq. Ref < Pump Min P1-06” will be displayed and the drive will run at the minimum pump speed.

■ Conditions for Exiting the Pre-Charge Mode

- When Pre-Charge timer expires (P4-03). The drive will always exit after the pre-charge timer expires.

4.6 U1000 iQpump Presets and Functions

- When the “Disable Pre-Charge” digital input (H1-□□ = 8C) is closed, even momentarily
- When the PID feedback satisfies Pre-Charge level (P4-01):
 Feedback is greater than Pre-Charge Level (P4-01) (forward-acting PID, b5-09 = 0)
 Feedback is less than Pre-Charge Level (P4-01) (reverse-acting PID, b5-09 = 1)
- When the “Low Water” digital input (H1-□□ = 8C) deactivates. A digital input must be programmed to “Low Water” (H1-0□ = 8F). The input is configured in P1-30 (0: normally open, 1: normally closed).

■ Related Parameters

No.	Parameter Name	Setting Values
P4-01	Pre-Charge Level	Default: 0.0 PSI Minimum: 0.0 Maximum: 6000.0
P4-02	Pre-Charge Frequency	Default: 0.0 Hz Minimum: 0.0 Maximum: [E1-04]
P4-03	Pre-Charge Time	Default: 0.0 min Minimum: 0.0 Maximum: 3600.0
P4-05	Pre-Charge Loss of Prime Level	Default: 0.0 A Minimum: 0.0 Maximum: 1000.0
P4-06	Pre-Charge Frequency 2	Default: 0.0 Hz Minimum: 0.0 Maximum: [E1-04]
P4-07	Pre-Charge Time 2	Default: 0.0 min Minimum: 0.0 Maximum: 3600.0
P4-08	Pre-Charge Loss of Prime Level 2	Default: 0.0 A Minimum: 0.0 Maximum: 1000.0

H1 Multi-Function Digital Input Settings

H1-□□ Setting	Function	Description
8C	Disable Pre-Charge	Closed: Pre-Charge disabled.

H2 Multi-Function Digital Output Settings

H2-□□ Setting	Function	Description
A4	Pre-Charge	Closed: Drive is in Pre-Charge mode.

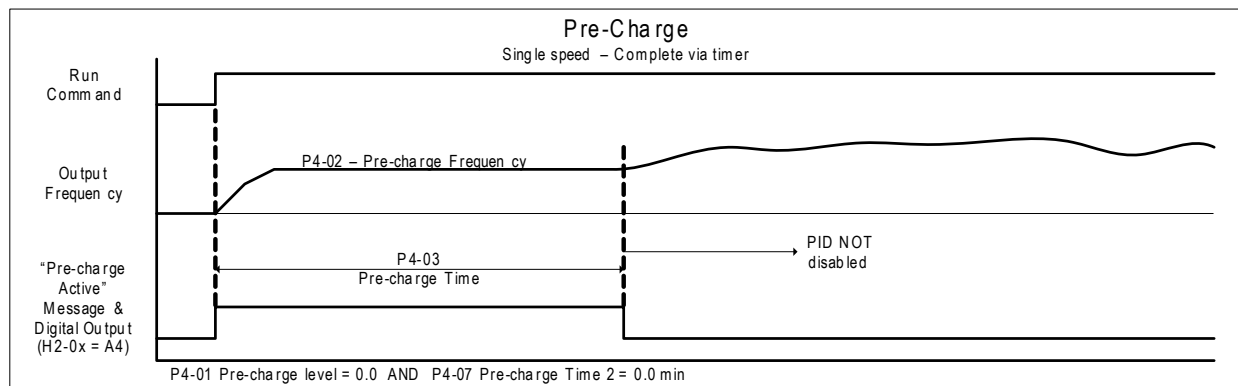

Figure 4.8 Pre-Charge Single Speed Complete via Timer

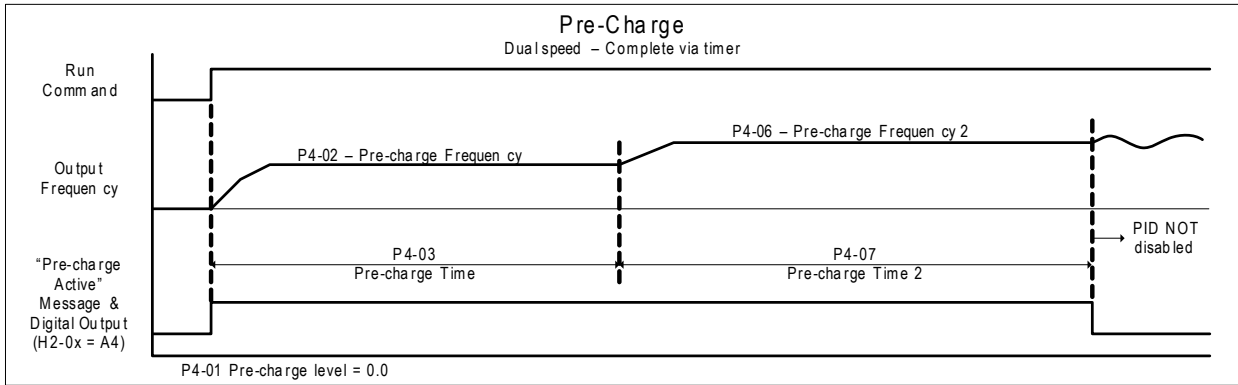

Figure 4.9 Pre-Charge Dual Speed Complete via Timer

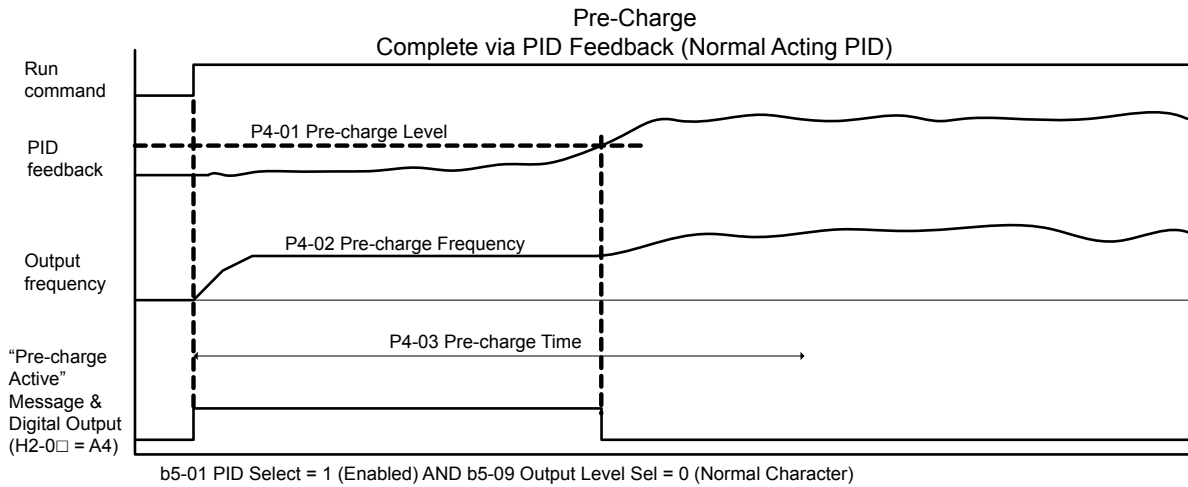

Figure 4.10 Pre-Charge Complete via Normal PID Feedback

◆ Setpoint Boost after Lag Pump De-staging

When a lag pump is de-staged (turned off), there can be a sudden drop in pressure in the system due to the pump de-staging. The Setpoint Boost function will dampen the shock load (pressure dip) to the system by temporarily raising the PI setpoint of the drive controller during de-staging.

The function will raise the setpoint to the measured feedback value at the time of de-staging for the time set in P3-11. When the P3-11 time expires, the setpoint will return to the Q1-01 value and the drive operates normally. The intention of the feature is to get the drive to begin accelerating as soon as a pump is de-staged, thus limiting the shock to the system since the PI controller would tell the drive to accelerate anyway in response the de-staged pump. It is not intended to regulate at the boosted setpoint for a long period of time.

- The maximum PI setpoint is limited to the Q1-01 setpoint plus the P3-10 (Max Boost at De-stage) setting.
- This feature cannot decrease the setpoint, therefore the function is disabled if b5-09 = 1 (inverse acting).
- If the drive calls for a lag pump to be staged during the P3-11 time, the staging will occur with the Setpoint Boost function being immediately disabled.
- Setting either P3-10 or P3-11 to zero disables the Setpoint Boost function.
- The PI control loop is active during Setpoint Boost.
- The default setting for P3-10 is 0.0 PSI and P3-11 is 5.0 sec.

While the setpoint is being controlled by the Setpoint Boost after De-stage function, the drive will display the message "Setpoint Boost Active (P3-11)."

■ Start Up Procedure

1. Set all other parameters required for the application such as PI control loop, sleep, motor, and I/O parameters. [Refer to Vertical Turbine Controller \(VTC\) on page 140](#) for an example. However, this function can be used in conjunction across a wide range of applications using a PI control process loop with multiple lag pumps that are staged and de-staged
2. Set the maximum Setpoint Boost in parameter (P3-10). This is set in the selected system units (PSI, etc.). When a de-staging occurs and Setpoint Boost is to occur, the PI feedback level temporarily becomes the PI setpoint. Parameter P3-10 limits how much the PI setpoint can be raised.
3. Set the Setpoint Boost time in parameter P3-11. This sets how long the Setpoint Boost function will boost the PI setpoint. After the P3-11 time expires, the PI setpoint will return to the Q1-01 setting.

■ Related Parameters

No.	Parameter Name	Setting Values
b5-09	PID Output Level Selection	Default: 0 Range: 0, 1
P3-10	Setpoint Boost Maximum at De-stage	Default: 0.0 PSI Minimum: -20.0 Maximum: 20.0
P3-11	Setpoint Boost after De-stage Time	Default: 5.0 s Minimum: 0.0 Maximum: 60.0
Q1-01	PID Controller Setpoint 1	Default: 0.0 Minimum: 0.0 Maximum: 6000.0

◆ Frequency Reduction after Lag Pump Staging

When a lag pump is staged (turned on), there can be a sudden increase in pressure in the system due to the pump staging on. The Frequency Reduction function will dampen the shock load (pressure spike) to the system by temporarily limiting (lowering) the drive controller output frequency during pump staging.

The function will limit the output frequency at time of de-staging for the time set in P3-07. When the P3-07 time expires, the frequency limit is removed and the drive operates normally. The intention of the feature is to get the drive to begin decelerating as soon as a pump is staged to limit the shock to the system, as the PI controller would tell the drive to decelerate in response the staged on pump. It is not intended to regulate at the limited output frequency for an extended period of time.

- Note:**
1. When a lag pump is staged on, the drive will upper-limit the output frequency for the P3-07 (Frequency Reduction Time) setting. The output frequency limit is determined by subtracting parameter P3-06 (Frequency Reduction at Staging) from parameter P3-03 (Max-Multi Level). The default setting for P3-03 is 59.0 Hz, P3-06 is 0.0 PSI, and P3-07 is 0.0 sec.
 2. The drive integrator will be limited to prevent wind-up and ensure a smooth transition back out of frequency limit.
 3. Once the P3-07 time expires, the upper-limit will be removed and the drive will operate normally.
 4. If the drive calls for de-staging a pump during the P3-07 time, the de-stage will be allowed to happen, and normal PI operation will immediately resume.
 5. If either P3-06 or P3-07 is set to zero, this feature will not operate.

While the output frequency is being controlled by the Frequency Reduction after Staging function, the drive will display the message "Freq Reduction Active (P3-07)."

■ Start Up Procedure

1. Set all other parameters required for the application such as PI control loop, sleep, motor, and I/O parameters. [Refer to Vertical Turbine Controller \(VTC\) on page 140](#) for an example. However, this function can be used in conjunction across a wide range of applications using a PI control process loop with multiple lag pumps that are staged and de-staged.
2. Set the amount of frequency reduction at staging in parameter P3-06. When a staging occurs, the output frequency is limited to P3-03 – P3-06.
Example: If P3-03 = 59 Hz (default) and P3-06 is set to 5.0 Hz, the output frequency will be limited to 54 Hz.
3. Set the Frequency Reduction time at staging in parameter P3-07. This sets how long the output frequency will be limited during pump staging. After the P3-07 time expires, the PI controller will return to normal.

■ Related Parameters

No.	Parameter Name	Setting Values
b5-09	PID Output Level Selection	Default: 0 Range: 0, 1
P3-10	Setpoint Boost Maximum at De-Stage	Default: 0.0 PSI Minimum: -20.0 Maximum: 20.0
P3-11	Setpoint Boost after De-Stage Time	Default: 5.0 s Minimum: 0.0 Maximum: 60.0
Q1-01	PID Controller Setpoint 1	Default: 0.0 Minimum: 0.0 Maximum: 6000.0

◆ Using the DO-A3 Option for Additional Lag Pumps

The drive comes standard with three output relays capable of controlling three lag pumps. With the addition of a DO-A3 card installed in the drive, two additional lag pumps can be controlled bring the total to five lag pumps.

■ Required Control Wiring

Install the DO-A3 option card on the CN5-A, CN5-B, or CN5-C option connector on the drive. Refer to the DO-A3 Installation Manual packaged with the option for installation and wiring instructions. The option card has two relay outputs on terminal block 1 (TB1) and 6 photocoupler outputs on terminal block 2 (TB2). the drive uses only the relay outputs on terminal block 1.

■ Start Up Procedure for Controlling a Lead Pump plus Five Lag Pumps

1. Install and wire the DO-A3 as indicated in the option installation manual.
2. Set all other parameters required for the application such as PI control loop, sleep, motor, and I/O parameters.
3. Program drive parameters with the values shown in [Table 4.7](#) to correctly control each lag pump.

Table 4.7 Lag Pump Settings

Lag Pump Number	Terminal Location	Terminal Numbers	Parameter	Setting
1	Control Board	M1-M2	H2-01	80
2		M3-M4	H2-02	81
3		MD-MF	H2-03	82
4	DO-A3 Option	M1-M2	F5-07	83
5		M3-M4	F5-08	84

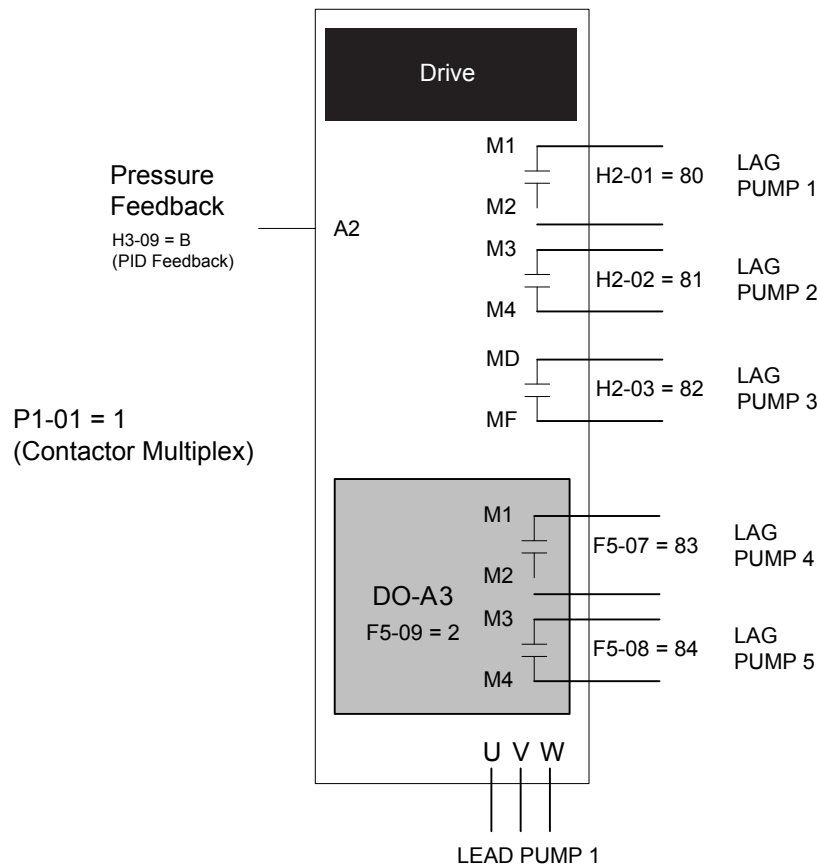

Figure 4.11 Controlling Five Lag Pumps with DO-A3 Option

◆ De-Scale/De-Ragging

The De-scale/De-ragging function attempts to clean the pump impellers (dislodge scale and buildup) by rapidly starting and stopping the pump in both directions. The drive monitors the number of operating hours of the motor and after a set amount of operating time, the drive runs the De-scale/De-ragging function the next time the drive is started in either the HAND or AUTO mode.

The De-scale/De-ragging function runs the drive forward, then reverse for a specified number of times before normal operation will automatically resume.

The De-Scale/De-ragging function operates when all of the following conditions are met:

- P8-01 = 1: De-Scale is Enabled
- P7-01 = 0: Anti-Jam Disabled

■ De-Scale/De-Ragging Operation

While the pump is running in the Hand or Auto mode, the De-scale/De-ragging run timer is activated. The timer data is stored in EEPROM at power-down. If the amount of time accumulated in the timer is less than the De-Scale Pump Run Time parameter (P8-08), the drive starts normally. When the timer is equal to or greater than the P8-08 value, the drive will automatically perform the de-scale function the next time the drive is at a stop and is commanded to accelerate in HAND or AUTO mode.

The “De-Scale/De-rag Active” alarm will flash on the keypad during the De-scale/De-ragging function. The drive will first accelerate using the De-scale Acceleration Time (P8-06) up to the De-scale Run Frequency Reference (P8-03), for the De-scale Forward Run Time (P8-04) time. It will then decelerate using the De-scale Deceleration Time (P8-07) and accelerate using P8-06 in the reverse direction. It will stay running at the P8-09 speed for the time set in the De-Scale Reverse Run Time (P8-05). After the timer expires, drive will decelerate to zero using P8-07. Once it reaches zero speed, it will immediately repeat the cycle for as many times as specified by the De-scale cycle count (P8-02) parameter. If the De-scale/De-ragging function is interrupted by a fault or by removing the run command, all timers associated with the De-scale/De-ragging function will be reset.

During de-scaling / de-ragging operation, the following features are disabled:

- PI Control (pressure control)
- Thrust Bearing Acceleration
- Minimum Speed
- Low Feedback / High Feedback Detection
- Not Maintaining Setpoint Detection
- Loss of Prime
- Low Flow / High Flow Detection
- Level Control / Suction Control / Vacuum Control
- Sleep Detection
- Sleep Boost

■ Forced De-Scale/De-Ragging Operation

When parameter P8-01 = 2 (Force De-scale), the drive will perform a De-scale/De-ragging operation every time it starts. This mode is intended to be used during the setup of the De-scale/De-ragging function only.

■ Related Parameters, Multi-Function Digital Output Settings, and Alarms

No.	Parameter Name	Setting Values
P8-01	De-scale Operation Selection	Default: 0 Range: 0 to 2
P8-02	De-scale Cycle Count	Default: 1 Range: 1 to 100
P8-03	De-scale Frequency Reference	Default: 25.00 Hz Range: 0.0 to 400.0
P8-04	De-scale Forward Run Time	Default: 10 s Range: 1 to 6000
P8-05	De-scale Reverse Run Time	Default: 10 s Range: 1 to 6000

4.6 U1000 iQpump Presets and Functions

No.	Parameter Name	Setting Values
P8-06	De-scale Acceleration Time	Default: 2.0 s Range: 0.0 to 600.0
P8-07	De-scale Deceleration Time	Default: 2.0 s Range: 0.0 to 600.0
P8-08	De-scale Pump Run Time	Default: 168.0 H Range: 0.1 to 2000.0
p8-09	De-scale Reverse Frequency Reference	Default: 25.00 Hz Range: 0.00 to 400.00

H2 Multi-Function Digital Output Settings

H2-□□	Function	Description
A6	De-scale Active	Closed: De-scale is running

◆ Flow Rate Limiter

The flow rate limiter function reduces speed when the flow rate reaches a high or low limit to reduce system pressure.

The drive reduces the output speed to limit the flow rate. Parameter P6-27 determines whether the Flow Rate Limit Level acts as a High Limit (P6-26 = 1) or a Low Limit (P6-26 = 2).

When P6-26 is set to 1 (Enabled), the output speed is reduced when the Flow Rate rapidly increases or rises above the level set in P6-27.

When P6-27 is set to 2 (Enabled – Low Limit), the output speed is reduced through a PI controller when the Flow Rate rapidly decreases or falls below the level set in P6-27. The output speed is lower-limited to the greater value between the Minimum Pump Speed (P1-06) or Thrust (P4-12), plus the Minimum Output Frequency (E1-09).

Parameters P6-28 (Proportional Gain) and P6-29 (Integral Time) adjust the responsiveness of the PI controller.

Flow Limit Start Delay (P6-30) sets the length of time that the drive will wait before activating the Flow Rate Limiter at Start.

Note: When the Flow Limit Start Delay (P6-30) timer expires, the output speed may rapidly decrease depending on the Flow Rate level compared to the Flow Limit (P6-27). Be sure to set P6-30 long enough to allow the system to stabilize the Flow Rate.

■ Total Accumulated Volume and Delta Accumulated Volume Monitors

Monitors U1-84 to U1-87 represent the Total Accumulated Volume as shown below:

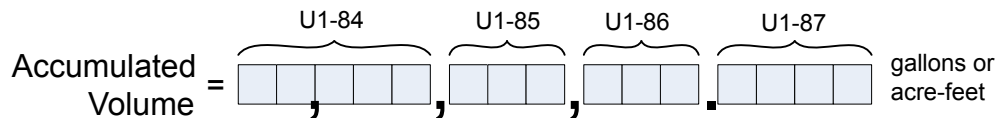

Monitor U1-88 provides the same information in a single display. The decimals are dropped when P6-16 is set to 1 to display in gallons. When the value being displayed is more than 99999 gal or units are in A-F (P6-16 = 2), the display will initially show “U1-88 = - - gal“ or “U1-88 = - - A-F” and immediately switch over to the full value with the monitor number removed.

The unit and commas may be removed depending on the size of the value. Note that the unit is always displayed in the Monitor Title Text (Total Vol (gal) or Total Vol (A-F)).

Monitor U1-89 shows the volume accumulated with the values stored in parameters P6-36 to P6-39 (Delta Volume) as the starting point. The display operates the same as U1-88, except that it can be signed and switched to full value display when above 9999 gal or below -9999 gal.



Note: When the units are in Acre-feet, the number of decimal places decreases by 1 when the value is above 9,999,999,999.9999 A-F or below -9,999,999,999.9999 A-F.

The value for U1-89 is equal to the Total Accumulated Volume (U1-88/U1-84 to U1-87) – Starting Delta Volume (P6-36 to P6-39).

Starting Delta Volume parameters P6-36 to P6-39 can be populated manually by individually setting each parameter. Setting P6-35 to 1 (Set) will write the current Total Accumulated Volume (U1-88/U1-84~U1-87) to the parameters, while setting P6-35 to 2 (Reset) will write 0 to these parameters.

4.6 U1000 iQpump Presets and Functions

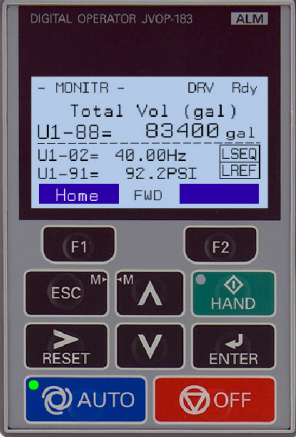
Sample Screens

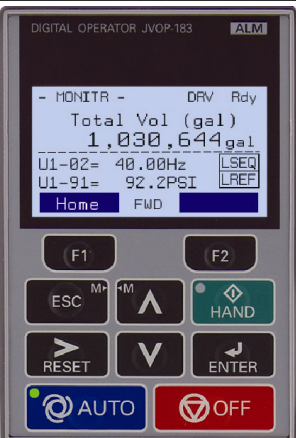
LCD Display	Description
 <p>The LCD display shows the following information: DIGITAL OPERATOR JVOP-183, ALM, - MONITR -, DRV Rdy, Total Vol (gal), U1-88= 83400 gal, U1-02= 40.00Hz, U1-91= 92.2PSI, LSEQ, LREF, Home, FWD.</p>	<p>Displaying in Gallons and value is less than 100,000. Displays normally.</p>
 <p>The LCD display shows the following information: DIGITAL OPERATOR JVOP-183, ALM, - MONITR -, DRV Rdy, Total Vol (gal), U1-88= -- gal, U1-02= 40.00Hz, U1-91= 92.2PSI, LSEQ, LREF, Home, FWD.</p>	<p>Displaying in gallons and value is greater than 99,999. Displays double dashes for 1.5 s, then displays the full value.</p>
 <p>The LCD display shows the following information: DIGITAL OPERATOR JVOP-183, ALM, - MONITR -, DRV Rdy, Total Vol (gal), 1,030,644 gal, U1-02= 40.00Hz, U1-91= 92.2PSI, LSEQ, LREF, Home, FWD.</p>	<p>Full value display with units and commas.</p>

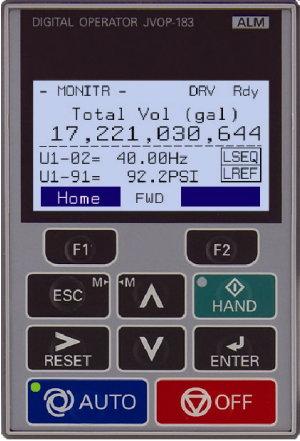
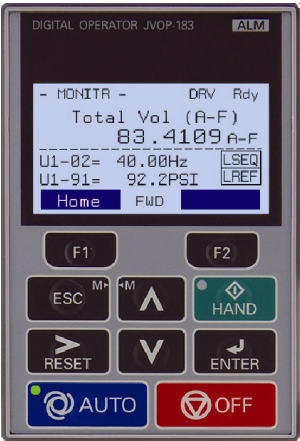
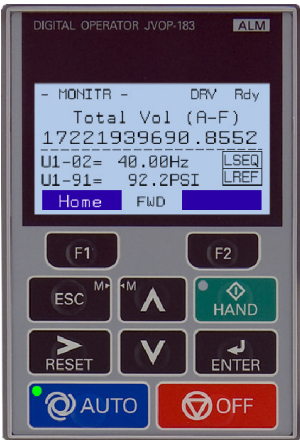
LCD Display	Description
 <p>The LCD display shows the following information: DIGITAL OPERATOR JVOP-183, ALM, - MONITR -, DRV Rdy, Total Vol (gal) 17,221,030,644, U1-02= 40.00Hz, U1-91= 92.2PSI, LSEQ, LREF, Home, FWD, F1, F2, ESC, HAND, RESET, ENTER, AUTO, OFF.</p>	<p>Full value display with commas, but no unit in-line.</p>
 <p>The LCD display shows the following information: DIGITAL OPERATOR JVOP-183, ALM, - MONITR -, DRV Rdy, Total Vol (A-F) 83.4109 A-F, U1-02= 40.00Hz, U1-91= 92.2PSI, LSEQ, LREF, Home, FWD, F1, F2, ESC, HAND, RESET, ENTER, AUTO, OFF.</p>	<p>Full value display for Acre-Feet units.</p>
 <p>The LCD display shows the following information: DIGITAL OPERATOR JVOP-183, ALM, - MONITR -, DRV Rdy, Total Vol (A-F) 17221939690.8552, U1-02= 40.00Hz, U1-91= 92.2PSI, LSEQ, LREF, Home, FWD, F1, F2, ESC, HAND, RESET, ENTER, AUTO, OFF.</p>	<p>Full value display with no units and no commas.</p>

4.6 U1000 iQpump Presets and Functions

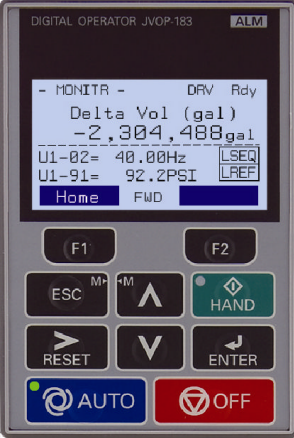
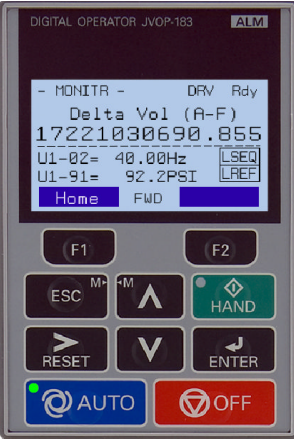
LCD Display	Description
 <p>The LCD display shows the following information: DIGITAL OPERATOR JVOP-183, ALM, - MONITR -, DRV Rdy, Delta Vol (gal) -2,304,488gal, U1-02= 40.00Hz, U1-91= 92.2PSI, LSEQ, LREF, Home, FWD.</p>	<p>Delta Volume: Full display with units, commas, and sign.</p>
 <p>The LCD display shows the following information: DIGITAL OPERATOR JVOP-183, ALM, - MONITR -, DRV Rdy, Delta Vol (A-F) 17221030690.855, U1-02= 40.00Hz, U1-91= 92.2PSI, LSEQ, LREF, Home, FWD.</p>	<p>Delta Volume: Full display with no units, no commas, and resolution decreased.</p>

■ Low Flow Detection Delay at Start Cancel

The Low Flow Rate detection is enabled when all of the following are true:

- There is a valid flow meter input: pulse input, analog input, or MEMOBUS network.
- The Low Flow Level parameter P6-06 > 0.
- The drive is running in Hand or Auto and the output frequency is greater than 0 for longer than the time set in P6-08.

■ Related Parameters, Monitors, and Multi-Function Digital Output Settings

No.	Parameter Name	Setting Values
P6-01	Flow Meter Scaling	Default: 0.0 GPM Range: 0.0 to 6000.0 GPM
P6-02	Turbine Input Scaling (Coarse)	Default: 0 ppG Range: 0 to 6000 ppG
P6-03	Turbine Input Scaling (Fine)	Default: 0.0000 ppG Range: 0.0000 to 0.9999 ppG
P6-06	Low Flow Level	Default: 0.0 Range: 0.0 to 6000.0
P6-07	Low Flow Detection Delay Time When Already Running	Default: 10 s Range: 0 to 6000 s
P6-08	Low Flow Detection Wait Time At Start	Default: 0.0 min Range: 0.0 to 3600.0 min
P6-09	Low Flow Select	Default: 1 Range: 0 to 3
P6-17	High Flow Level	Default: 0.0 Range: 0.0 to 6000.0

No.	Parameter Name	Setting Values
P6-21	Low Flow Detection Delay @ Start Cancel Time	Default: 5 s Range: 0 to 6000 s
P6-22	Flow Meter Decimal Place Position	Default: 1 Range: 0 to 2
P6-26	Flow Limit Selection	Default: 0 Range: 0 to 2
P6-27	Flow Limit Level	Default: 0.0 Range: 0.0 to 6000.0
P6-28	Flow Limit Regulator Gain	Default: 0.00 Range: 0.00 to 25.00
P6-29	Flow Limit Regulator Integral Time	Default: 1.00 s Range: 0.00 to 25.00 s
P6-30	Flow Limit Regulator Delay @ Start	Default: 10 s Range: 0 to 6000 s
P6-35	Accumulator Delta Save Selection	Default: 0 Range: 0 to 2
P6-36	Delta Starting Accumulation Level - Millions	Default: 0 Range: 0 to 65535
P6-37	Delta Starting Accumulation Level - Thousands	Default: 0 Range: 0 to 999
P6-38	Delta Starting Accumulation Level - Ones	Default: 0 Range: 0 to 999
P6-39	Delta Starting Accumulation Level - Decimal	Default: 0.0000 Range: 0.0000 to 0.9999
U1-83	Flow Rate	Full scale: P6-01 Setting
U1-88	Total Volume Accumulated	Full scale: N/A
U1-89	Delta Volume Accumulated	Full scale: N/A

H2 Multi-Function Digital Output Settings		
H2-□□	Function	Description
A7	Flow Rate Limit	Closed: The Flow Rate is actively affecting the output speed.

◆ Multi-function Digital Input On/Off Time Delay

This function provides an On/Off Delay to all multi-function digital inputs.

When the terminal closes, the function programmed to that terminal activates after the corresponding on-delay timer elapses. Opening the terminal will reset the on-delay timer. When the terminal opens and the function is active, the function continues to run until the off-delay timer elapses. Closing the terminal again will reset the off-delay timer.

The on-delay and off-delay timers also affect monitor U1-10 (Input Terminal Status). The corresponding bits are set when the function is active after the on-delay elapses. The bits are reset when the function is deactivated after the off-delay elapses. The on-delay timer does not apply when the inputs are already closed at power-up.

■ Related Parameters

No.	Parameter Name	Setting Values
H1-37, H1-38	Terminals S7 and S8 On-Delay Time	Default: 0.00 s Range: 0.00 to 300.00 s
H1-41 to H1-48	Terminals S1 to S8 Off-Delay Time	Default: 0.00 s Range: 0.00 to 300.00 s

◆ PI Auxiliary Control

PI Auxiliary Control allows the drive to control pressure when the PI Auxiliary Level is adequate. When the PI Auxiliary Control Level drops to the PI Auxiliary Control Setpoint set in Q6-03, the drive will regulate based on the PI Aux Level and the pressure will drop.

The drive also goes to sleep, wakes up, and trips an alarm and/or fault based on the PI Auxiliary Control level.

■ Enable PI Aux Level Control Features

Set parameter Q6-01 to 1 to enable PI Aux Level Control and PI Aux Low Level Detection.

The drive performs PI Aux Level Control when Q6-20 is set to 1 and the drive is in PID mode (PID enabled via b5-01, not jogging, and not disabled by other functions).

Sleep via Minimum and Maximum Levels (Q6-04 and Q6-24) apply to both Q6-20 modes.

■ Scaling and Resolution

Q6-21 sets the unit and Q6-22 sets the decimal place for the PI Aux Level parameters and monitors.

■ Data Entry Modes for Wake-up Level, Low Level, and High Level Detection

Parameter/Condition	Delta Entry	Absolute Entry	Range Display (Toggles Automatically)
Q6-06 Wake-up Level PI Direct-acting (Q6-23 = 0)	-0.0 to -999.9	0.0 to 999.9	(0.0 to 999.9) <-> “-Sub frm SetPt”
Q6-06 Wake-up Level PI Inverse-acting (Q6-23 = 1)	+0.0 to +999.9	0.0 to 999.9	(0.0~999.9) <-> “+Add to SetPt”
Q6-09 Low Feedback Level	-0.0 to -999.9	0.0 to 999.9	(0.0 to 999.9) <-> “-Sub frm SetPt”
Q6-12 High Feedback Level	+0.0 to +999.9	0.0 to 999.9	(0.0~999.9) <-> “+Add to SetPt”

■ Sensing PI Aux Feedback Level

Set a multi-function analog input H3-□□ to 27 to act as the PI Auxiliary Feedback Level and set parameter Q6-02 to the full-scale pressure of the transducer, with units and decimal place set by Q6-21 and Q6-22. This level is displayed on the U1-96 monitor.

Wire break is detected for the PI Aux FB Level analog input when all of the following are true:

- Q6-19 ≠ 0 to enable PI Aux Feedback Wire-Break Detection.
- Q6-01 = 1 enabling PI Auxiliary Control.
- The multi-function analog input programmed for PI Aux FB Level (H3-□□ = 27) is set for 4 to 20 mA operation (H3-□□ = 2)
- The signal on the analog input falls below 3 mA or rises above 21 mA for longer than 1 second.

The drive responds based on the Q6-19 setting:

- Setting 0: Wire-break detection is disabled.

- Setting 1: The “AUXFB – PI Aux Lvl Loss” alarm will display.
- Setting 2: The drive will trigger an “AUXFB – PI Aux Lvl Loss” fault if the drive is in Auto, Hand, or Sleep. If there is not a Run command present, the drive will display an “AUXFB – PI Aux Lvl Loss” alarm.

■ Direct-Acting PI Aux Level Control (Q6-23 = 0)

The drive will respond in one of two ways to a change in the PI Aux Feedback when Q6-23 is set to 0:

- The drive will attempt to regulate to the Q6-03 level when Q6-03 setpoint < Q6-24 maximum level.

The drive slows down as the feedback level approaches the Q6-03 setting and pressure and flow decrease. The drive then regulates output speed to maintain the PI Aux Level. Adjust the drive regulating level responsiveness using parameters Q6-16 and Q6-17.

The drive will go to sleep if level rises above the Q6-24 maximum value for longer than the Q6-05 sleep delay time. Normal operation resumes when the feedback level falls below the Q6-06 wake-up level for longer than the Q6-07 wake-up time.

Note: Be sure to set Q6-08, PI Aux Control Minimum Speed, to a value high enough to ensure flow.

- The drive will attempt to maintain the pressure setpoint before immediately going to sleep based on PI Aux Feedback when Q6-03 setpoint > Q6-24 maximum level.

The drive goes to sleep when the Feedback Level rises above the Q6-24 maximum level for longer than the Q6-05 sleep delay time. Normal operation resumes when the PI Aux Feedback falls below the Q6-06 level for longer than the Q6-07 time.

■ Inverse-Acting PI Aux Level Control (Q6-23 = 1)

The drive will respond in one of two ways to a change in the PI Aux Feedback when Q6-23 is set to 1:

- The drive will attempt to regulate to the Q6-03 level when Q6-03 setpoint > Q6-24 maximum level.

The drive slows down as the feedback level approaches the Q6-03 setting and pressure and flow decrease. The drive then regulates output speed to maintain the PI Aux Level. Adjust the drive regulating level responsiveness using parameters Q6-16 and Q6-17.

The drive will go to sleep if level falls below the Q6-24 maximum value for longer than the Q6-05 sleep delay time. Normal operation resumes when the feedback level rises above the Q6-06 wake-up level for longer than the Q6-07 wake-up time.

Note: Be sure to set Q6-08, PI Aux Control Minimum Speed, to a value high enough to ensure flow.

- The drive will attempt to maintain the pressure setpoint before immediately going to sleep based on PI Aux Feedback when Q6-03 setpoint < Q6-24 maximum level.

The drive goes to sleep when the Feedback Level falls below the Q6-24 maximum level for longer than the Q6-05 sleep delay time. Normal operation resumes when the PI Aux Feedback rises above the Q6-06 level for longer than the Q6-07 time.

■ Sleep & Wake-Up Methods

The drive goes to sleep in one of three separate methods:

- The drive goes to sleep without performing a sleep boost when the PI Aux Feedback falls below the Minimum Level (Q6-04) for longer than the PI Auxiliary Control Sleep Delay Time (Q6-05),

The drive wakes up when the PI Aux Feedback level rises above the Setpoint (Q6-03) for longer than the time set in Q6-07 and the standard (pressure) sleep function set in P1-04 and P1-05 calls for a wake-up.

- The drive goes to sleep without performing a sleep boost when the PI Aux feedback rises above the Maximum Level (Q6-24) for longer than the PI Auxiliary Control Sleep Delay Time (Q6-05).

The drive wakes up when the PI Aux Feedback level falls below the Setpoint (Q6-03) for longer than the time set in Q6-07 and the standard (pressure) sleep function set in P1-04 and P1-05 calls for a wake-up.

- The drive will also go to sleep based upon the standard sleep settings set in parameters P2-01 to P2-04 and perform a sleep boost.

When Q6-23 is set to 1 (Inverse-acting), the drive wakes up when the PI Aux Feedback rises above the Setpoint (Q6-03) for longer than the Q6-07 time AND the standard sleep function set in P1-04 and P1-05 calls for a wake-up.

When Q6-23 is set to 0 (Direct-acting), the drive wakes up when the PI Aux Feedback falls below the Setpoint (Q6-03) for longer than the Q6-07 time AND the standard sleep function set in P1-04 and P1-05 calls for a wake-up.

■ PI Aux Low Level Detection

Set Q6-01 to 1 and Q6-09 > 0 to enable PI Aux Low Level Detection.

4.6 U1000 iQpump Presets and Functions

Low Level Behavior – No Display:

The Low PI Aux Level digital output (H2-0□ = 9E) closes when Q6-11 = 0 (No Display) and the PI Aux Feedback falls below the level set in Q6-09. The digital output opens when the feedback rises above the level set in Q6-09.

Low Level Behavior – Alarm Only:

The “LOAUX – Low PI Aux Lvl” alarm displays and the digital output closes when Q6-11 = 1 (Alarm Only) and the PI Aux Feedback falls below the level set in Q6-09. The alarm clears and the digital output opens when the feedback rises above the level set in Q6-09.

Low Level Behavior – Fault:

The digital output closes and the alarm displays when Q6-11 = 2 or 3 (Fault), the output frequency > 0, and the PI Aux Feedback falls below the level set in Q6-09. The drive faults out with a “LOAUX – Low PI Aux Lvl” fault if the feedback remains below the Q6-09 level for the time set in Q6-10.

Low Level Behavior – Auto-Restart:

The drive attempts to auto-restart after the PI Aux Level Control Auto-Restart Time (Q6-15) expires if the drive faults out on a “LOAUX – Low PI Aux Lvl” Fault, parameter Q6-11 = 3, and L5-01 > 0 to enable auto-restarts. The auto-restart counter increments and the drive remains faulted until the feedback rises above the level set in Q6-09.

■ PI Aux High Level Detection

Set Q6-01 to 1 and Q6-12 > 0 to enable PI Aux High Level Detection.

High Level Behavior – No Display:

The High PI Aux Level digital output (H2-0□ = 9F) closes when Q6-14 = 0 (No Display) and the PI Aux Feedback rises above the level set in Q6-12. The digital output opens when the feedback falls below the level set in Q6-12.

High Level Behavior – Alarm Only:

The “HIAUX – Hi PI Aux Lvl” alarm displays and the digital output closes when Q6-14 = 1 (Alarm Only) and the PI Aux Feedback rises above the level set in Q6-12. The alarm clears and the digital output opens when the feedback falls below the level set in Q6-12.

High Level Behavior – Fault:

The digital output closes and the alarm displays when Q6-14 = 2 or 3 (Fault), the output frequency > 0, and the PI Aux Feedback goes rises above the level set in Q6-12. The drive faults out with a “HIAUX – Hi PI Aux Lvl” fault when the feedback remains above the Q6-12 level for the Q6-13,

High Level Behavior – Auto-Restart:

The drive attempts to auto-restart after the PI Aux Level Control Auto-Restart Time (Q6-15) expires if the drive faults out on a “HIAUX – Hi PI Aux Lvl” Fault, parameter Q6-14 = “3, and L5-01 > 0 to enable auto-restarts. The auto-restart counter increments and the drive remains faulted until the feedback falls below the level set in Q6-12.

■ Related Parameters

No.	Parameter Name	Setting Values
Q6-01	PI Auxiliary Control Selection	Default: 0 Range: 0, 1
Q6-02	PI Auxiliary Control Feedback Scale	Default: 145.0 Range: 1.0 to 600.0
Q6-03	PI Auxiliary Control Setpoint	Default: 20.0 Range: 0.0 to 6000.0
Q6-04	PI Auxiliary Control Minimum Level	Default: 10.0 Range: 0.0 to 6000.0
Q6-05	PI Auxiliary Control Sleep Delay Time	Default: 5 s Range: 0 to 3600 s
Q6-06	PI Auxiliary Control Wake-up Level	Default: 30.0 Range: 0.00 to 999.9
Q6-07	PI Auxiliary Control Wake-up Time	Default: 1 s Range: 0 to 3600 s
Q6-08	PI Auxiliary Control Minimum Speed	Default: 0.00 Hz Range: 0.00 to 400.00 Hz

No.	Parameter Name	Setting Values
Q6-09	PI Auxiliary Control Low Level Detection	Default: 0.0 Range: 0.0 to 999.9
Q6-10	PI Auxiliary Control Low Level Detection Time	Default: 0.1 min Range: 0.0 to 300.0 min
Q6-11	PI Auxiliary Control Low Level Detection Selection	Default: 1 Range: 0 to 3
Q6-12	PI Auxiliary Control High Level Detection	Default: 0.0 Range: 0.0 to 999.9
Q6-13	PI Auxiliary Control High Level Detection Time	Default: 0.1 min Range: 0.0 to 300.0 min
Q6-14	PI Auxiliary Control High Level Detection Selection	Default: 1 Range: 0 to 3
Q6-15	PI Auxiliary Control Level Detection Restart Time	Default: 5.0 min Range: 0.1 to 6000.0 min
Q6-16	PI Auxiliary Control P Gain	Default: 2.00 Range: 0.00 to 25.00
Q6-17	PI Auxiliary Control I Time	Default: 5.0 s Range: 0.0 to 360.0 s
Q6-18	PI Auxiliary Control Detection Time Unit	Default: 0 Range: 0, 1
Q6-19	PI Auxiliary Control Feedback Wirebreak	Default: 2 Range: 0 to 2
Q6-20	PI Auxiliary Control Main PI Control	Default: 1 Range: 0, 1
Q6-21	PI Auxiliary Control Level Unit Selection	Default: 1 Range: 0 to 11; 26
Q6-22	PI Auxiliary Control Level Decimal Place Position	Default: 1 Range: 0 to 3
Q6-23	PI Auxiliary Control Output Level Selection	Default: 1 Range: 0, 1
Q6-24	PI Auxiliary Control Maximum Level	Default: 0.0 Range: 0.0 to 6000.0
Q6-25	PI Auxiliary Control Activation Level	Default: 0.0 PSI Range: 0.0 to 6000.0
Q6-26	PI Auxiliary Control Activation/Deactivation Delay	Default: 2 s Range: 0 to 3600 s
Q6-32	PI Aux Units Custom 1 st Character	Default: 41 Range: 20 to 7A
Q6-33	PI Aux Units Custom 2 nd Character	Default: 41 Range: 20 to 7A
Q6-34	PI Aux Units Custom 3 rd Character	Default: 41 Range: 20 to 7A
U1-96	PI Auxiliary Control Feedback Level	–

H1 Multi-Function Digital Input Settings		
H1-□□	Function	Description
82	PI Switch to Aux	Closed: PI Auxiliary Control (Q6-□□) becomes the primary PI loop, disabling the System PI controller (b5-□□). Overrides Q6-20 if set to 0 (Disable Effect on Speed Control).

H2 Multi-Function Digital Output Settings		
H2-□□	Function	Description
9E	Low PI Aux Lvl	Energizes when the PI Aux Feedback Level falls below the Low PI Aux Level (Q6-09), or if there is a LOAUX – Low PI Aux Level Fault.
9F	Hi PI Aux Lvl	Energizes when the PI Aux Feedback Level rises above the High PI Aux Level (Q6-12), or if there is a HIAUX – Hi PI Aux Lvl Fault.

4.6 U1000 iQpump Presets and Functions

H2 Multi-Function Digital Output Settings		
H2-□□	Function	Description
A0	WL/SP/PIAux Ctrl	Closed when the Water Level, Suction Pressure, or PI Auxiliary Controller is affecting the output speed.

H3 Multi-Function Analog Input Settings (H3-02/H3-06/H3-10)		
H3-02/06/10	Function	Description
27	PI Auxiliary Feedback Level	0 V or 4 mA = 0 (unit based on Q6-22) 10 V or 20 mA = Q6-02 (unit based on Q6-22)

◆ Hybrid Sequence Control

■ CALL Alarm at Power Up

Parameter H5-13 enables and disables the “CALL” alarm that occurs at power-up when the Sequence or Reference Source is set for Serial or Option.

Run Source: AUTO Key + Terminals (b1-02/b1-16 = 6), AUTO Key + Serial (b1-02/b1-16 = 7), or AUTO Key + Option (b1-02/b1-16 = 8)

When b1-02 or b1-16 are set to 6, the AUTO key puts the drive in Auto Mode and the terminal programmed for Run (H1-□□ = 40, 41, or 42) acts as the External Run command.

When b1-02 or b1-16 are set to 7, the AUTO key puts the drive into Auto Mode and the Serial Run command (register 0001) acts as the External Run command.

When b1-02 or b1-16 are set to 8, the AUTO key puts the drive in Auto mode and the Option Card Run command acts as the External Run command.

All of these settings establish the Run command when the AUTO key and External Run command are active.

Pressing the AUTO key when the External Run command is not present will latch the key and cause the AUTO LED to blink. Pressing OFF will unlatch the AUTO key.

Issuing the External Run command before latching the AUTO key will cause the AUTO LED to blink and indicate an incomplete Run command. Removing the External RUN command will stop the AUTO LED from blinking. The drive will run in AUTO Mode when the AUTO key is latched and the External RUN command is present.

The following table shows possible combinations and their effect on the drive:

AUTO Key Latched	External Run	AUTO LED	Drive Runs?	Description
No	No	OFF	No	Drive stopped
Yes	No	Blinking	No	AUTO key latched, waiting for Run
No	Yes	Blinking	No	Run command given, waiting for AUTO key
Yes	Yes	ON	Yes	AUTO Mode Run

Note: Set P4-10 to 1 (Auto Mode Operation Power-Down Storage enabled) to save the AUTO key latch through a power-cycle.

■ Related Parameters

No.	Parameter Name	Setting Values
b1-02	Run Command Selection 1	Default: 0 Range: 0 to 3; 6 to 8
b1-16	Run Command Selection 2	Default: 0 Range: 0 to 3; 6 to 8
H5-13	Power-up CALL Alarm	Default: 0 Range: 0, 1

4.6 U1000 iQpump Presets and Functions

◆ Differential Level Detection

Differential Level Detection detects the pressure difference between the PID Feedback (H3-□□ = B) and a secondary pressure feedback device (H3-□□ = 28).

■ Enable Differential Level Detection

Ensure that all of the following conditions are met to enable Differential PI Feedback Detection:

- P4-18 > 0
- Program the Differential Feedback analog input (H3-□□ = 28)
- The drive is not in Anti-Jam or De-scale operation
- For Direct-Acting PID, the drive is running in AUTO mode (including sleep boost and feedback drop detection)

For Inverse-Acting PID, the drive has a Run command present.

With detection enabled, the drive detects the pressure difference between the PID Feedback and the Differential Feedback (H3-□□ = 28).

The digital output programmed for “Differential Det” (H2-□□ = A1) closes when the difference exceeds the level set in P4-18 for the time set in P4-19.

The drive responds depending on the setting for P4-20 (Differential Detection Selection)

The drive triggers a “Differential FB Detected” alarm and closes the digital output when P4-20 is set to 1 (Alarm).

The drive triggers a “DIFF Difference Det” fault and closes the digital output when P4-20 is set to 0 (Fault) The digital output stays closed while the “DIFF Difference Det” fault is active and will open when the difference falls below the P4-18 setting for 1 s or when detection feature is disabled.

The drive triggers the digital output only when P4-10 is set to 2 (Digital Out Only).

■ Related Parameters

No.	Parameter Name	Setting Values
P4-18	Differential Level	Default: 10.0 Range: 0.0 to 6000.0
P4-19	Differential Level Detection Time	Default: 10 s Range: 0 to 3600 s
P4-20	Differential Level Detection Selection	Default: 0 Range: 0 to 2
U1-81	Differential PI Feedback	–

H2 Multi-Function Digital Output Settings

H2-□□	Function	Description
A1	Differential Det	Closed: The difference between the PID Feedback and the Differential Feedback (H3-□□ = 28) exceeded the P4-18 level for the time set in P4-19.

H3 Multi-Function Analog Input Settings (H3-02/H3-06/H3-10)

H3-□□	Function	Description
28	Differential PI Feedback	Full scale: FB Device Scaling (P1-03)

4.7 Basic U1000 iQpump Setup and Application Preset Parameters

This section explains the basic settings required for initial drive operation. Checking these basic parameter settings will help to ensure a successful drive start-up. *Refer to Parameter List on page 319* for a complete listing of drive parameters if more information is required for parameters not listed in this section.

■ A1-01: Access Level Selection

Allows or restricts access to drive parameters.

No.	Parameter Name	Setting Range	Default
A1-01	Access Level Selection	0 to 3	2

Setting 0: Operation only

Access to only parameters A1-01, A1-04, and all U monitor parameters.

Setting 1: User Parameters

Access to only a specific list of parameters set to A2-01 through A2-32. These User Parameters can be accessed using the Setup Mode of the digital operator.

Setting 2: Advanced Access Level (A) and Setup Access Level (S)

All parameters can be viewed and edited.

Setting 3: Lock Parameters

Parameters that are normally visible in the advanced access level (A1-01 = 2) are still visible, but the only parameters that can be changed are A1-01 and A1-04.

The Auto Tuning and Pump Quick Setup menus will not be displayed.

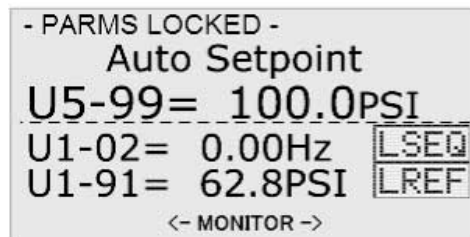

Figure 4.12 Help Message Example (Optional HOA Keypad, JVOP-183, Home Screen)

Notes on Parameter Access

- If the drive parameters are password protected by A1-04 and A1-05, parameters A1-00 through A1-03, A1-06, and all A2 parameters cannot be modified.
- If a digital input terminal programmed for “Program lockout” (H1-□□ = 1B) is enabled, parameter values cannot be modified, even if A1-01 is set to 1 or 2.
- If parameters are changed via serial communication, it will not be possible to edit or change parameter settings with the digital operator until an Enter command is issued to the drive from the serial communication.

■ A1-03: Initialize Parameters

Resets parameters to default values or performs an Application Preset for fan or pump applications. After initialization, the setting for A1-03 automatically returns to 0.

No.	Parameter Name	Setting Range	Default
A1-03	Initialize Parameters	0, 1110, 2220, 3330, 5550, 6008, 6009, 6011, 6012, 6013, 6014, 7770, 7771	0

Setting 1110: User Initialize

Resets parameters to the values selected by the user as User Settings. User Settings are stored when parameter o2-03 is set to “1: Set defaults”.

Note: User Initialization resets all parameters to a user-defined set of default values previously saved to the drive. Set parameter o2-03 to 2 to clear the user-defined default values.

4.7 Basic U1000 iQpump Setup and Application Preset Parameters

Setting 2220: 2-Wire Initialization

Resets parameters to default settings with digital inputs S1 and S2 configured as Forward run and Reverse run, respectively.

Setting 3330: 3-Wire Initialization

Resets parameters to default settings with digital inputs S1, S2, and S5 configured as Run, Stop, and Forward/Reverse respectively. [Refer to Setting 0: 3-Wire Sequence on page 176](#) for more information on digital input functions.

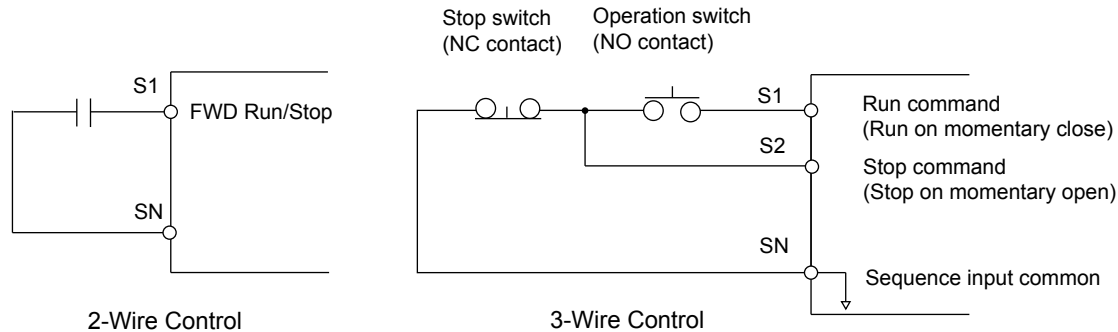

Figure 4.13 2 & 3-Wire Control Wiring Examples

Notes on Parameter Initialization

The parameters shown in [Table 4.8](#) will not be reset when the drive is initialized by setting A1-03 = 2220 or 3330.

Table 4.8 Parameters Not Changed by Drive Initialization

No.	Parameter Name
A1-00	Language Selection
E1-03	V/f Pattern Selection
F6-08	Communication Parameter Reset
L8-35	Installation Selection
o2-04	Drive/kVA Selection

Setting 5550: Terminal/Control Initialize

An oPE04 error appears on the digital operator when a terminal block with settings saved to its built-in memory is installed in a drive that has edited parameters. Set A1-03 to 5550 to use the parameter settings saved to the terminal block memory.

Application Presets are available to facilitate drive setup for commonly used applications. Selecting one of these Application Presets automatically assigns functions to the input and output terminals and sets a predefined group of parameters to values appropriate for the selected application.

In addition, the parameters most likely to be changed are assigned to the group of User Parameters, A2-01 through A2-16. User Parameters are part of the Setup Group, which provides quicker access by eliminating the need to scroll through multiple menus.

[Refer to Pump Application Presets on page 125](#) for detailed information on Application Presets.

Setting 6008: Pressure Control

Application Preset for Pressure Control applications. [Refer to Pump Application Presets on page 125](#) for a list of parameters and default values for this Application Preset.

Setting 6009: Pump Down Level

Application Preset for Pump Down Level applications. [Refer to Pump Application Presets on page 125](#) for a list of parameters and default values for this Application Preset.

Setting 6011: VTC Pressure Mode

Application Preset for VTC Pressure Mode. [Refer to Pump Application Presets on page 125](#) for a list of parameters and default values for this Application Preset.

Setting 6012: Pivot Panel VTC

Application Preset for Pivot Panel VTC. [Refer to Pump Application Presets on page 125](#) for a list of parameters and default values for this Application Preset.

Setting 6013: Advanced Pressure Control

Application Preset for Advanced Pressure Control. *Refer to Pump Application Presets on page 125* for a list of parameters and default values for this Application Preset.

Setting 6014: Pivot Panel Submersible

Application Preset for Pivot Panel Submersible Control. *Refer to Pump Application Presets on page 125* for a list of parameters and default values for this Application Preset.

Setting 7770: General Purpose

General Purpose Application Preset. *Refer to Pump Application Presets on page 125* for a list of parameters and default values for this Application Preset.

Setting 7771: Submersible Motor General Purpose Operation

General Purpose Application Preset. *Refer to Pump Application Presets on page 125* for a list of parameters and default values for this Application Preset.

■ A1-08: Custom Initialize Modes

No.	Parameter Name	Setting Range	Default
A1-08	Custom Initialize Modes	0, 3005, 3006	0

0: No Initialization

3005: General Ext HOA

AUTO Run = S1,
 Speed = A2
 HAND1 Run = S6,
 Speed = A1
 HAND2 Run = S7,
 Speed = P5-05 or Operator
 Switch to Net Coms = S8;
 AUTO Run = Serial Run,
 Speed = Serial Comms

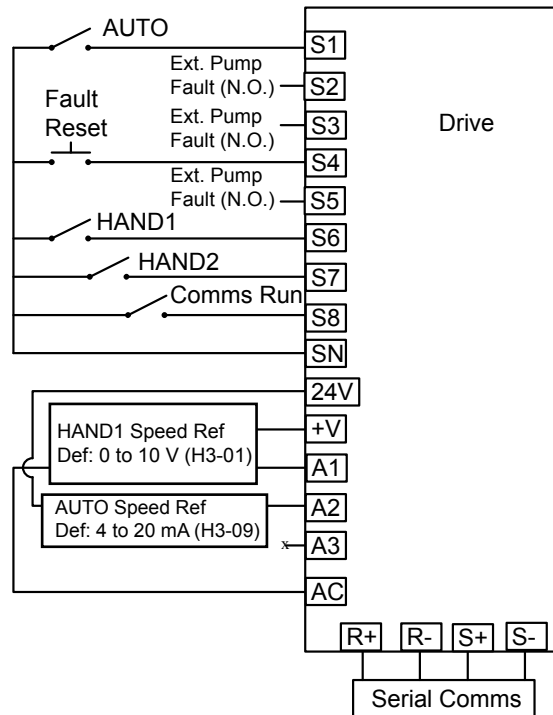

Figure 4.14 Default Port Configuration for General Ext HOA

4.7 Basic U1000 iQpump Setup and Application Preset Parameters

3006: General HOA Keys

AUTO Run = AUTO key + S1,
 Speed = A2
 HAND1 Run = S6,
 Speed = P5-02
 or Operator when P5-01 = 1,
 otherwise Terminal A1
 HAND2 Run = S7,
 Speed = P5-05 or Operator

Switch to Net Coms = S8;
 AUTO Run = Auto key + Serial Run,
 Speed = Serial Comms

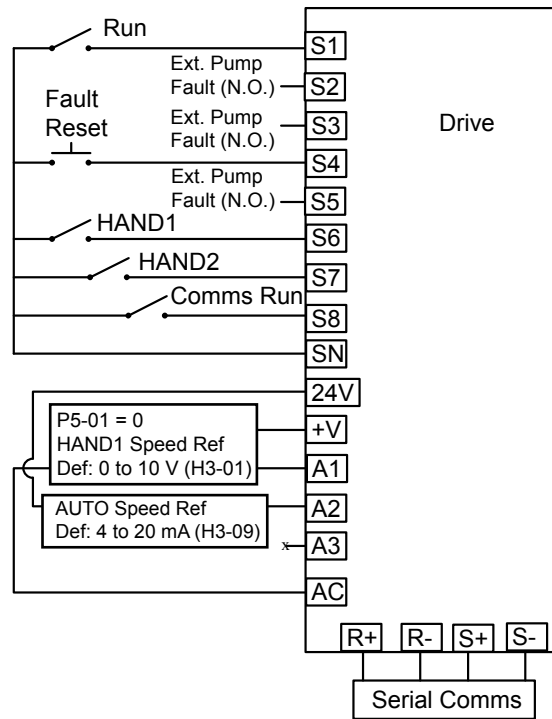

Figure 4.15 Default Port Configuration for General HOA Keys

Parameters Set Depending on A1-08 Setting

The following table shows the parameters that are set depending on the A1-08 initialization:

A1-08 = 3005 (A1-06 = 5) General Ext HOA		A1-08 = 3006 (A1-06 = 6) General HOA Keys	
Parameter	Value	Parameter	Value
A1-02	0	A1-02	0
b1-01	1	b1-01	1
b1-02	1	b1-02	6
b1-03	0	b1-03	0
b1-15	2	b1-15	2
b1-16	2	b1-16	7
b5-01	0	b5-01	0
C1-01	25.0 s	C1-01	25.0 s
C1-02	25.0 s	C1-02	25.0 s
H1-02	26H	H1-02	26H
H1-05	26H	H1-05	26H
H1-08	2	H1-08	2
H2-01	0H	H2-01	0H
H2-02	AH	H2-02	AH
H3-02	20H	H3-02	20H

4.7 Basic U1000 iQpump Setup and Application Preset Parameters

A1-08 = 3005 (A1-06 = 5) General Ext HOA		A1-08 = 3006 (A1-06 = 6) General HOA Keys	
Parameter	Value	Parameter	Value
H3-06	1FH	H3-06	1FH
H3-10	0	H3-10	0
L5-04	180.0 s	L5-04	180.0 s
o1-06	0	o1-06	0
P1-05	0 s	P1-05	0 s
P1-06	0.0 Hz	P1-06	0.0 Hz
P4-12	0.0 Hz	P4-12	0.0 Hz
P4-17	0.0 min	P4-17	0.0 min
P5-01	0	P5-02	0.0 Hz
P5-03	1	P5-03	1
P5-04	0	-	-

Parameters Displayed Depending on A1-08 Setting

The following table shows which parameters are shown on the Pump Quick Setting menu depending on the A1-08 selection:

A1-08 = 3005 (A1-06 = 5) General Ext HOA	A1-08 = 3006 (A1-06 = 6) General HOA Keys
C1-01	C1-01
C1-02	C1-02
E2-01	E2-01
E2-04	E2-04
H1-02	H1-02
H1-03	H1-03
H1-05	H1-05
L5-01	L5-01
L5-04	L5-04
P1-06	P1-06
P5-05	P5-02

■ b1-01: Frequency Reference Selection 1

Selects the frequency reference source 1 for the REMOTE mode.

Note: If a Run command is input to the drive but the frequency reference entered is 0 or below the minimum frequency, the RUN indicator LED on the digital operator will light and the STOP indicator will flash.

No.	Parameter Name	Setting Range	Default
b1-01	Frequency Reference Selection 1	0 to 4	0

In order to run the drive and motor, the drive must receive a Run command and an Auto Setpoint command. Parameter b1-01 specifies the origin of the Auto setpoint when in AUTO Mode. Switch to AUTO mode by pressing the AUTO button on the HOA keypad while the drive is stopped.

Note: If a Run command is input to the drive without a corresponding Auto setpoint, the Run indicator on the HOA keypad will turn on and the STOP indicator on the keypad will blink.

If the drive should follow the “HAND Reference” set by the HOA keypad, use HAND Mode by pressing the HAND key and set P5-01 to “1: Hand Reference (P5-02).” The HAND reference can then be entered into the U1-01 monitor parameter in the “-DRIVE-” Menu.

The drive offers the ability to provide four types of “Auto Setpoint” reference sources. These Auto Setpoint reference sources are determined by the setting of b1-01 and the drive set to AUTO Mode by pressing the AUTO key on the keypad.

Prior to programming, it is recommended to select the system units (P1-02) and the feedback device, Scaling (P1-03) first. P1-03 will automatically scale the drive setpoint.

Example: P1-02 = 1: PSI

P1-03 = 200, feedback range = 200 PSI.

4.7 Basic U1000 iQpump Setup and Application Preset Parameters

If the drive should follow an “Auto Set-Point” set by the HOA keypad: Set b1-01 to “0: Operator” (factory default). The Auto setpoint can then be entered into the U1-01 monitor parameter in the “-DRIVE-” menu.

Setting 0: Operator (HOA keypad)

Using this setting, the frequency reference can be input by:

- switching between the multi-speed references in the d1-□□ parameters.
- entering the frequency reference on the operator keypad.

This selection will also switch PID setpoint to Q1-01.

Setting 1: Terminals (analog input terminals)

Using this setting, an analog frequency reference can be entered as a voltage or current signal from terminals A1, A2, or A3. To set the drive to follow an “Auto Setpoint” set by the analog input, set b1-01 to 1 (Terminals) and connect a potentiometer or external signal to the drive.

Note: When b1-01 is set to 1 (Terminals) and P5-01 is set to 0 (HAND Mode Reference), the setpoint and the HAND reference are determined by the external analog signal.

Voltage Input

Voltage input can be used at any of the three analog input terminals. Make the settings as described in [Table 4.9](#) for the input used.

Table 4.9 Analog Input Settings for Frequency Reference Using Voltage Signals

Terminal	Signal Level	Parameter Settings				Notes
		Signal Level Selection	Function Selection	Gain	Bias	
A1	0 to 10 Vdc	H3-01 = 0	H3-02 = 0 (Frequency Reference Bias)	H3-03	H3-04	-
	0 to 10 Vdc Bipolar	H3-01 = 1				
A2	0 to 10 Vdc	H3-09 = 0	H3-10 = 0 (Frequency Reference Bias)	H3-11	H3-12	Set jumper S1 on the terminal board to “V” for voltage input.
	0 to 10 Vdc Bipolar	H3-09 = 1				
A3	0 to 10 Vdc	H3-05 = 0	H3-06 = 0 (Frequency Reference Bias)	H3-07	H3-08	Set DIP switch S4 on the terminal board to “AI”.
	0 to 10 Vdc Bipolar	H3-05 = 1				

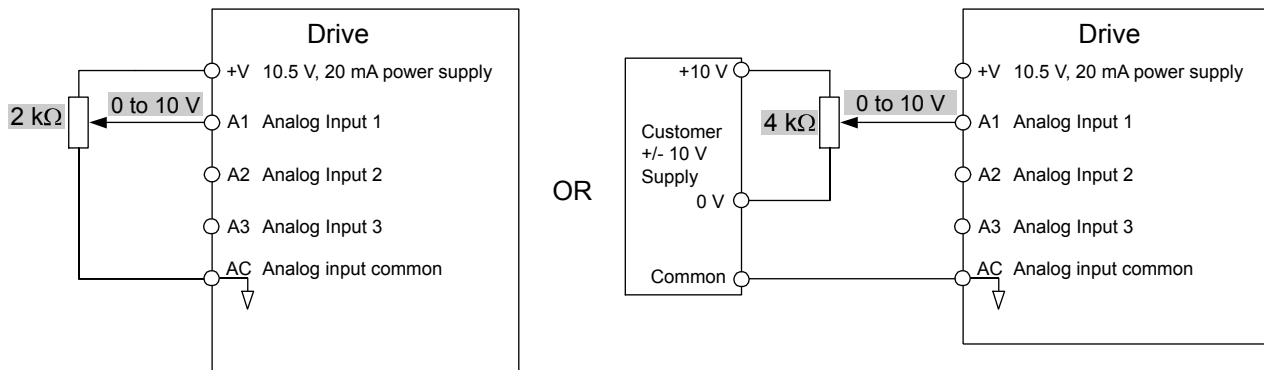

Figure 4.16 Setting the Frequency Reference as a Voltage Signal at Terminal A1

Current Input

Input terminals, A1, A2, and A3 can accept a current input signal. Refer to [Table 4.10](#) for an example to set terminal A2 for current input.

Table 4.10 Analog Input Settings for Frequency Reference Using a Current Signal

Terminal	Signal Level	Parameter Settings				Notes
		Signal Level Selection	Function Selection	Gain	Bias	
A2	4 to 20 mA	H3-09 = 2	H3-10 = 0 (Frequency Bias)	H3-11	H3-12	Make sure to set jumper S1 on the terminal board to “I” for current input.
	0 to 20 mA	H3-09 = 3				

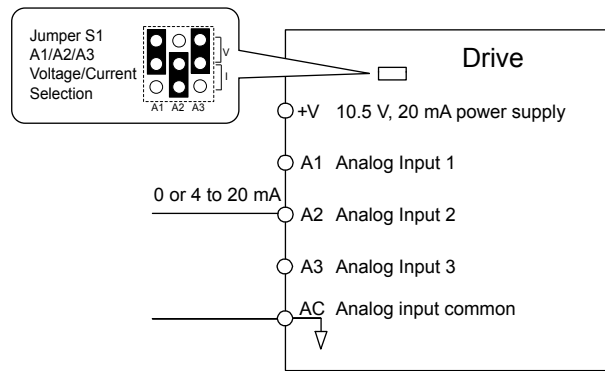

Figure 4.17 Setting the Frequency Reference as a Current Signal to Terminal A2

Switching between Main/Auxiliary Frequency References

The frequency reference input can be switched between the analog terminals A1, A2, and A3 using multi-speed inputs. To use several speed references for a multi-step speed sequence, set the H1-□□ parameters to 3, 4, 5, and 32. To assign the Jog reference to a digital input, set H1-□□ to 6.

Setting 2: Serial Communications

This setting requires entering the frequency reference via the RS-485/422 serial communications port (control terminals R+, R-, S+, S-).

To setup the drive to receive the “Auto Setpoint” from serial communication, set b1-01 to “2: Serial Com,” and connect the RS-422/RS-485 serial communications cable to terminals R+, R-, S+, and S- on the control I/O terminal block. Refer to [169](#) to see the connection diagram using a PC to provide the auto setpoint reference to the drive.

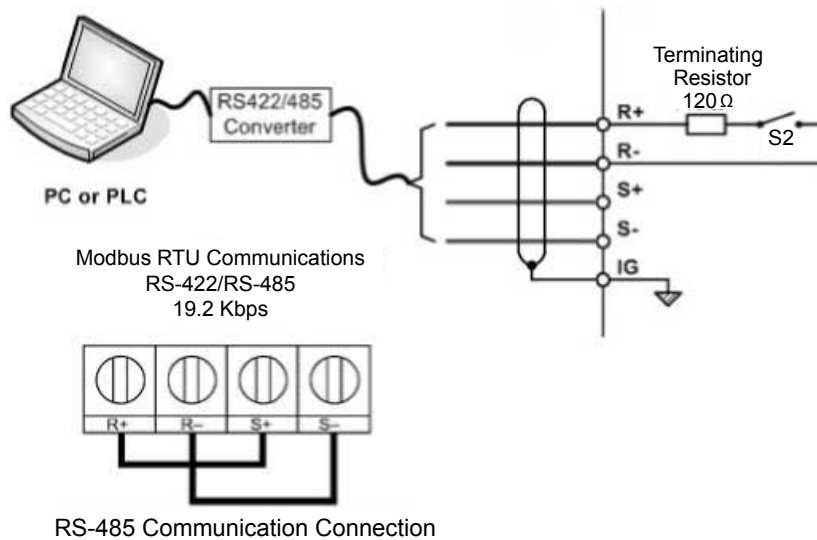

Figure 4.18 PC or PLC Connection Diagram

Setting 3: Option card

This setting requires entering the frequency reference via an option board plugged into connector CN5-A on the drive control board. Consult the option board manual for instructions on integrating the drive with the communication system.

Note: If the frequency reference source is set for Option PCB (b1-01 = 3), but an option board is not installed, an oPE05 Operator Programming Error will be displayed on the digital operator and the drive will not run.

To setup the drive to receive the “Auto Setpoint” for a network communication option card, set b1-01 to “3: Option PCB”, and plug a supported communication option card into the drive control PCB. Consult the manual supplied with the option for instructions on integrating the drive into the network system.

[Refer to Option Installation on page 297](#) for a list of available drive network communication options.

4.7 Basic U1000 iQpump Setup and Application Preset Parameters

Setting 4: Pulse Train Input

This setting requires a pulse train signal to terminal RP to provide the frequency reference. Follow the directions below to verify that the pulse signal is working properly.

Verifying the Pulse Train is Working Properly

- Set b1-04 to 4 and set H6-01 to 0.
- Set the H6-02 to the pulse train frequency value that equals 100% of the frequency reference.
- Enter a pulse train signal to terminal RP and check for the correct frequency reference on the display.

■ b1-02: Run Command Selection 1

Determines the Run command source 1 in AUTO Mode.

The drive comes factory programmed for Start and Stop from the keypad, but the user can program the drive to receive a Run command from four different inputs: digital operator, terminals, serial communications, or an option PCB.

To set the drive to receive the Run command from the HOA keypad, set b1-02 to “0: Operator,” and the HAND key will be used to provide the Run command to the drive.

To set the drive to receive the Run command from the external terminals, set b1-02 to “1: Terminals” and initiate an external Run command by a contact closure between terminals S1 and SN.

Note: Using the external terminals requires setting the drive to AUTO Mode by pressing the AUTO key.

No.	Parameter Name	Setting Range	Default
b1-02	Run Command Selection 1	0 to 3; 6 to 8	0

Setting 0: Operator (HOA keypad)

This setting requires entering the Run command via the HOA keypad AUTO key and also illuminates the HAND indicator on the digital operator.

Setting 1: Control Circuit Terminal

This setting requires entering the Run command via the digital input terminals using one of following sequences:

- 2-Wire sequence 1:

Two inputs (FWD/Stop-REV/Stop). Set A1-03 to 2220 to initialize the drive and preset terminals S1 and S2 to these functions. This is the default setting of the drive.

- 2-Wire sequence 2:

Two inputs (Start/Stop-FWD/REV).

- 3-Wire sequence:

Three inputs (Start-Stop-FWD/REV). Set A1-03 to 3330 to initialize the drive and preset terminals S1, S2, and S5 to these functions. [Refer to Setting 0: 3-Wire Sequence on page 176.](#)

Setting 2: MEMOBUS/Modbus Communications

This setting requires entering the Run command via serial communications by connecting the RS-485/422 serial communication cable to control terminals R+, R-, S+, and S- on the removable terminal block.

Setting 3: Option Card

This setting requires entering the Run command via the communication option board by plugging a communication option board into the CN5-A port on the control PCB. Refer to the option board manual for instructions on integrating the drive into the communication system.

Note: If b1-02 is set to 3, but an option board is not installed in CN5-A, an oPE05 operator programming error will be displayed on the digital operator and the drive will not run.

Setting 6: AUTOKey + Term

When b1-02/b1-16 = 6, the AUTO key puts the drive into AUTO mode and the terminal programmed for Run (H1-□□ = 40, 41, or 42) acts as the External Run command.

Setting 7: AUTOKey + Serial

When b1-02/b1-16 = 7, the AUTO key puts the drive into AUTO mode and the Serial Run command (register 0001) acts as the External Run command.

Setting 8: AUTOKey + Option

When b1-02/b1-16 = 8, the AUTO key puts the drive into AUTO mode and the Option Card Run command acts as the External Run command.

■ b1-03: Stopping Method Selection

Selects how the drive stops the motor when the Run command is removed or when a Stop command is entered.

Note: Parameter b1-11, Run Delay at Stop (Back Spin Timer), is effective for all stopping methods (b1-03 = 0 to 3), not only Coast to Stop w/ Timer (b1-03 =3).

No.	Parameter Name	Setting Range	Default
b1-03	Stopping Method Selection	0 to 3	1

Setting 0: Ramp to Stop

When the Run command is removed, the drive will decelerate the motor to stop. The deceleration rate is determined by the active deceleration time. The default deceleration time is set to parameter C1-02.

When the output frequency falls below the level set in parameter b2-01, the drive will start DC injection, Zero Speed Control, or Short Circuit Braking.

Setting 1: Coast to Stop

When the Run command is removed, the drive will shut off its output and the motor will coast (uncontrolled deceleration) to stop. The stopping time is determined by the inertia and the friction in the driven system.

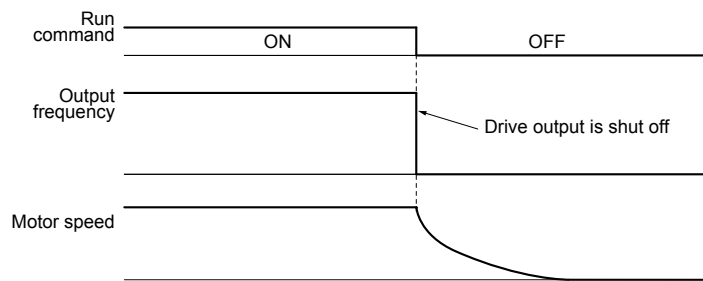

Figure 4.19 Coast to Stop

Note: After a stop is initiated, any subsequent Run command entered will be ignored until the minimum baseblock time (L2-03) has expired. Do not enter Run command until it has come to a complete stop. Use DC Injection at Start (Refer to b2: DC Injection Braking on page 324) or Speed Search (Refer to b3: Speed Search on page 324) to restart the motor before it has completely stopped.

Setting 2: DC Injection Braking to Stop

When the Run command is removed, the drive will enter baseblock (turn off its output) for the minimum baseblock time (L2-03). When the minimum baseblock time has expired, the drive will inject the amount DC Injection Braking is set in parameter b2-02 into the motor windings to brake the motor. The stopping time in DC Injection Braking to Stop is significantly faster compared to Coast to Stop.

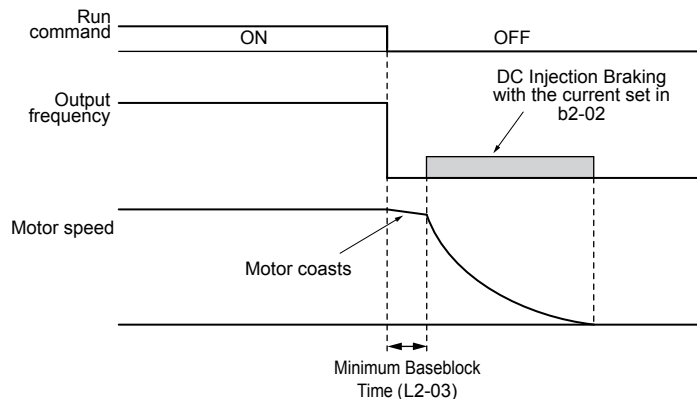

Figure 4.20 DC Injection Braking to Stop

DC Injection Braking time is determined by the value set to b2-04 and the output frequency at the time the Run command is removed. It can be calculated by:

$$\text{DC Injection brake time} = \frac{(b2-04) \times 10 \times \text{Output frequency}}{\text{Maximum output frequency (E1-04)}}$$

4.7 Basic U1000 iQpump Setup and Application Preset Parameters

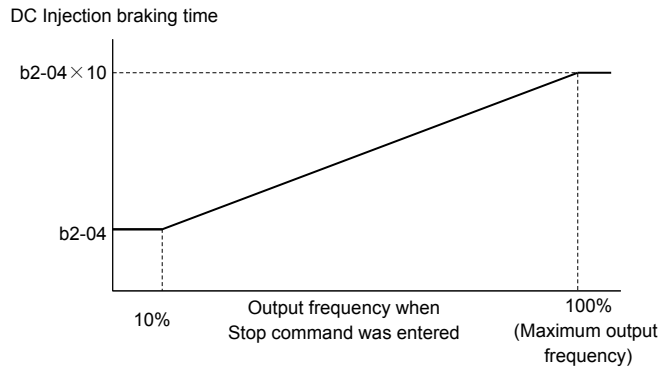

Figure 4.21 DC Injection Braking Time Depending on Output Frequency

Note: If an overcurrent (oC) fault occurs during DC Injection Braking to Stop, lengthen the minimum baseblock time (L2-03) until the fault no longer occurs.

Setting 3: Coast to Stop with Timer (Used for Back Spin Control on Vertical Turbine Pumps)

When the Run command is removed, the drive coasts to a stop. If parameter b1-11 is set to zero, the coast-timer (Run Delay at Stop) becomes a value determined by a combination of output frequency and the C1-02 parameter. However, if b1-11 is set greater than zero, the Run Delay at Stop timer is set to b1-11. If the Run command is reissued during the Run Delay at Stop timer time, the drive WILL restart when the timer expires without the need to cycle the Run command. The Run Delay at Stop timer will operate for both AUTO Mode and HAND Mode. The Run Delay at Stop timer will still operate when the drive goes to sleep and then wakes up. During the Run Delay at Stop timer execution, the HOA keypad will display the alarm “WrUn”. Both Alarm and Run indicators will blink while the drive waits to execute the Run command.

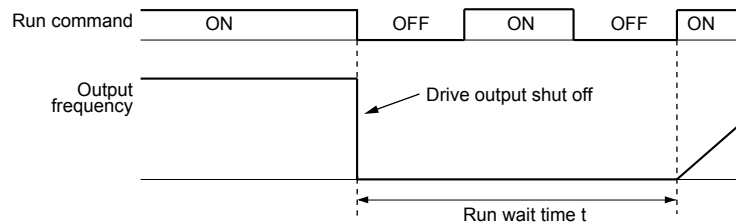

Figure 4.22 Coast to Stop with Timer

The wait time t is determined by the output frequency when the Run command is removed and by the active deceleration time.

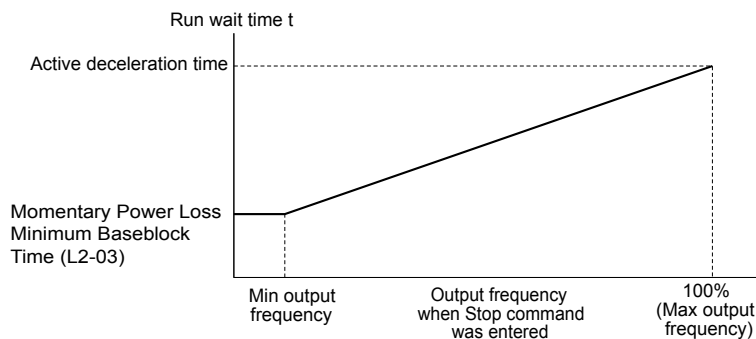

Figure 4.23 Run Wait Time Depending on Output Frequency

■ b3-01: Speed Search Selection at Start

Determines if Speed Search is automatically performed when a Run command is issued.

No.	Parameter Name	Setting Range	Default
b3-01	Speed Search Selection at Start	0, 1	0

Setting 0: Disabled

This setting starts operating the drive at the minimum output frequency when the Run command is entered. If external Speed Search 1 or 2 is already enabled by a digital input, the drive will start operating with Speed Search.

Setting 1: Enabled

This setting performs Speed Search when the Run command is entered. The drive begins running the motor after Speed Search is complete.

■ **b5-01: PID Function Setting**

Enables and disables the PID operation and selects the PID operation mode.

No.	Parameter Name	Setting Range	Default
b5-01	PID Function Setting	0, 1	1

Setting 0: PID disabled

Setting 1: Output frequency = PID output 1

The PID controller is enabled and the PID output builds the frequency reference. The PID input is D controlled.

■ **b5-02: Proportional Gain Setting (P)**

Sets the P gain applied to the PID input. Larger values will tend to reduce the error but may cause oscillations if set too high, while lower values may allow too much offset between the setpoint and feedback. The function of b5-02 is disabled when P1-24 > 0.

No.	Name	Setting Range	Default
b5-02	Proportional Gain Setting (P)	0.00 to 25.00	2.00

■ **b5-03: Integral Time Setting (I)**

Sets the time constant used to calculate the integral of the PID input. The shorter the integral time set to b5-03, the faster the offset will be eliminated. If the integral time is set too short, however, overshoot or oscillation may occur. To turn off the integral time, set b5-03 to 0.00.

No.	Name	Setting Range	Default
b5-03	Integral Time Setting (I)	0.0 to 360.0 s	3.0 s

■ **b5-09: PID Output Level Selection**

Reverses the sign of the PID controller output signal. Normally a positive PID input (feedback smaller than setpoint) leads to positive PID output.

No.	Parameter Name	Setting Range	Default
b5-09	PID Output Level Selection	0, 1	0

Setting 0: Direct Acting

A positive PID input causes an increase in the PID output (direct acting).

Setting 1: Inverse Acting

A positive PID input causes a decrease in the PID output (inverse acting).

■ **b5-39: PID Setpoint User Display, PID Setpoint Display Digits**

Sets a user-defined display for the PID setpoint (b5-19) and PID feedback monitors (U5-01, U5-04). The setting value is equal to the number of decimal places.

No.	Name	Setting Range	Default
b5-39	PID Setpoint Display Digits	0 to 3	1

4.7 Basic U1000 iQpump Setup and Application Preset Parameters

Setting 0: No Decimal Places

Setting 1: One Decimal Place

Setting 2: Two Decimal Places

Setting 3: Three Decimal Places

■ C1-01 to C1-04: Accel, Decel Times 1 and 2

Two different sets of acceleration and deceleration times can be set in the drive by digital inputs, motor selection, or switched automatically.

Acceleration time parameters always set the time to accelerate from 0 Hz to the maximum output frequency (E1-04).

Deceleration time parameters always set the time to decelerate from maximum output frequency to 0 Hz. C1-01 and C1-02 are the default active accel/decel settings.

No.	Parameter Name	Setting Range	Default
C1-01	Acceleration Time 1	0.0 to 6000.0 s <1>	20.0 s
C1-02	Deceleration Time 1		
C1-03	Acceleration Time 2		
C1-04	Deceleration Time 2		

<1> The setting range for the acceleration and deceleration times is determined by the accel/decel time setting units in C1-10. For example, if the time is set in units of 0.01 s (C1-10 = 0), the setting range becomes 0.00 to 600.00 s.

Switching Acceleration Times by Digital Input

Accel/decel time 1 is active by default if no input is set. Activate accel/decel times 2, 3, and 4 by digital inputs (H1-□□ = 7 and 1A) as explained in [Table 4.11](#).

Table 4.11 Accel/Decel Time Selection by Digital Input

Accel/Decel Time Sel. 1 H1-□□ = 7	Accel/Decel Time Sel. 2 H1-□□ = 1A	Active Times	
		Acceleration	Deceleration
0	0	C1-01	C1-02
1	0	C1-03	C1-04

[Figure 4.24](#) shows an operation example for changing accel/decel. times. The example below requires that the stopping method be set for “Ramp to stop” (b1-03 = 0).

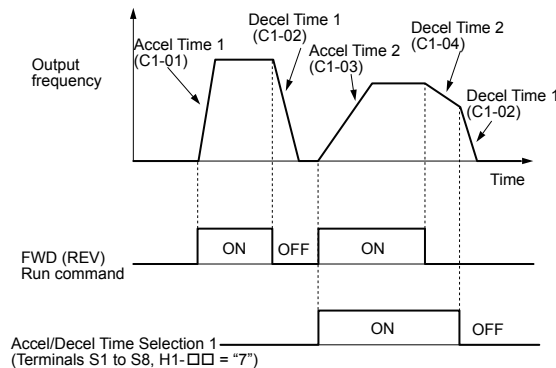

Figure 4.24 Timing Diagram of Accel/Decel Time Change

■ E2-01: Motor Rated Current

Provides motor control, protects the motor, and calculates torque limits. Set E2-01 to the full load amps (FLA) stamped on the motor nameplate. If Auto-Tuning completes successfully, the value entered to T1-04 will automatically be saved to E2-01.

No.	Parameter Name	Setting Range	Default
E2-01	Motor Rated Current	10% to 150% of the drive rated current <1>	Determined by o2-04

<1> Display is in the following units:
 2A0028, 2A0042 and 2A0011; 4A0011 to 4A0027: 0.01 A units.
 2A0054 to 2A0248 and 4A0034 to 4A0930: 0.1 A units.

Note: An oPE02 error will occur if $E2-01 \leq E2-03$. Set E2-03 correctly to prevent this error.

■ E2-04: Number of Motor Poles

Set the number of motor poles to E2-04. If Auto-Tuning completes successfully, the value entered to T1-06 will automatically be saved to E2-04.

No.	Parameter Name	Setting Range	Default
E2-04	Number of Motor Poles	2 to 48	2

■ H1-01 to H1-08: Functions for Terminals S1 to S8

These parameters assign functions to the multi-function digital inputs. The various functions and settings are listed in [Table 4.12](#).

No.	Parameter Name	Setting Range	Default
H1-01	Multi-Function Digital Input Terminal S1 Function Selection	0 to B0	40 (F) <1> : Forward Run Command (2-Wire sequence)
H1-02	Multi-Function Digital Input Terminal S2 Function Selection	0 to B0	F (F): Through Mode
H1-03	Multi-Function Digital Input Terminal S3 Function Selection	0 to B0	26: External Pump Fault
H1-04	Multi-Function Digital Input Terminal S4 Function Selection	0 to 9F	14: Fault Reset
H1-05	Multi-Function Digital Input Terminal S5 Function Selection	0 to B0	8D (0) <1> : Multi Setpoint 1
H1-06	Multi-Function Digital Input Terminal S6 Function Selection	0 to B0	80 (3) <1> : HAND Mode
H1-07	Multi-Function Digital Input Terminal S7 Function Selection	0 to B0	81 (4) <1> : HAND Mode 2
H1-08	Multi-Function Digital Input Terminal S8 Function Selection	0 to B0	F <1> : Through Mode

<1> Number appearing in parenthesis is the default value after performing a 3-Wire initialization (A1-03 = 3330).

Table 4.12 Multi-Function Digital Input Terminal Settings

Setting	Function	Setting	Function
0	3-Wire sequence	32	Multi-Step Speed Reference 4
2	External Reference 1/2 Selection	34	PID soft starter cancel
3	Multi-Step Speed Reference 1	35	PID input level selection
4	Multi-Step Speed Reference 2	40	Forward run command (2-Wire sequence)
5	Multi-Step Speed Reference 3	41	Reverse run command (2-Wire sequence)
6	Jog reference selection	42	Run command (2-Wire sequence 2)
7	Accel/decel time selection 1	43	FWD/REV command (2-Wire sequence 2)
8	Baseblock command (N.O.)	47	Node setup
9	Baseblock command (N.C.)	51	Sequence Timer Disable
A	Accel/decel ramp hold	52	Sequence Timer Cancel
B	Drive overheat alarm (oH2)	60	DC Injection Braking command
C	Analog terminal input selection	61	External Speed Search command 1
F	Through mode	62	External Speed Search command 2
10	Up command	63	Field weakening
11	Down command	67	Communications test mode
12	Forward Jog	68	High Slip Braking (HSB)
13	Reverse Jog	6A	Drive enable
14	Fault reset	73	Low City Press
15	Fast Stop (N.O.)	75	Up 2 command
17	Fast Stop (N.C.)	76	Down 2 command
18	Timer function input	80	HAND Mode
19	PID disable	81	HAND Mode 2
1A	Accel/decel time selection 2	82	PI Switch to Aux
1B	Program lockout		
1E	Reference sample hold		
20 to 2F	Ext. pump fault		
30	PID integral reset		
31	PID integral hold		

4.7 Basic U1000 iQpump Setup and Application Preset Parameters

Setting	Function
83	Alternate Multi-Setpoint (Q1-02)
84	Alternate Multi-Setpoint (Q1-03)
85	Alternate Multi-Setpoint (Q1-04)
88	Volute-Thermostat Normally Open
89	Volute-Thermostat Normally Closed
8C	Disable Pre-Charge
8D	Multi Setpoint 1
8E	Multi Setpoint 2
8F	Low Water Level

Setting	Function
90	High Water Level
92	Reset Accum
95	Remove Drive Disable
A8	Secondary PI Disable (N.O.)
A9	Secondary PI Disable (N.C.)
AA	Secondary PI Inverse Operation
AB	Secondary PI Integral Reset
AC	Secondary PI Integral Hold
AD	Select Secondary PI Parameters

Setting 0: 3-Wire Sequence

The digital input programmed for 3-Wire control becomes the forward/reverse directional input, S1 becomes the Run command input, and S2 becomes the Stop command input.

The drive starts the motor when the input S1 set for the Run command closes for longer than 2 ms. The drive stops the operation when the Stop input S2 releases for 2 ms. When the digital input programmed for a forward/reverse operation is open, the drive is set for forward operation. When the digital input is closed, the drive is set for reverse operation.

Note: Input the Run and Stop commands via S1 and S2 when selecting a 3-Wire sequence.

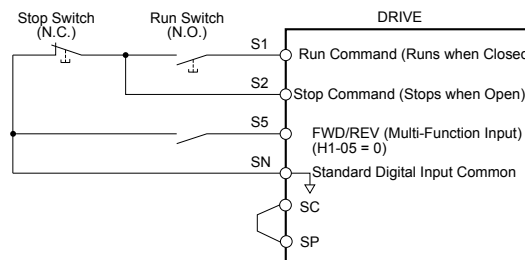

Figure 4.25 3-Wire Sequence Wiring Diagram

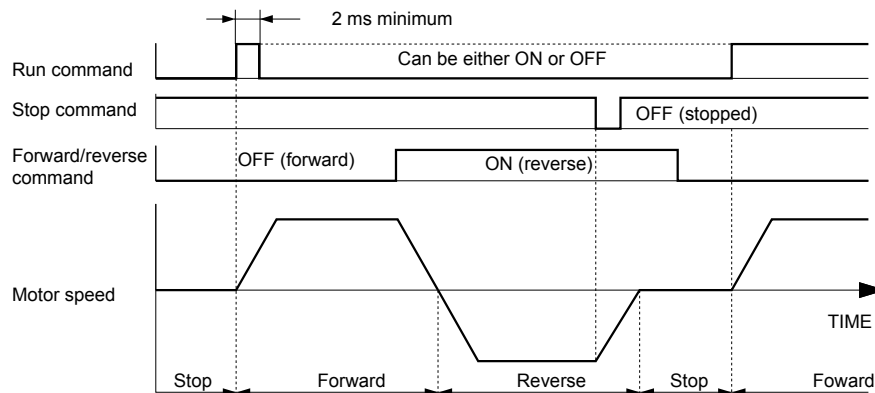

Figure 4.26 3-Wire Sequence

- Note:**
1. The Run command must be closed for more than 2 ms.
 2. If the Run command is active at power up and b1-17 = 0 (Run command at power up not accepted), the Run LED will flash to indicate that protective functions are operating. If required by the application, set b1-17 to 1 to automatically issue the Run command upon drive power up.

WARNING! Sudden Movement Hazard. Ensure start/stop and safety circuits are wired properly and in the correct state before applying power to the drive. Failure to comply could result in death or serious injury from moving equipment.

WARNING! Sudden Movement Hazard. The drive may start unexpectedly in reverse direction after power up if it is wired for 3-Wire sequence but set up for 2-Wire sequence (default). Make sure b1-17 is set to "0" (drive does not accept a Run command active at power up). When initializing the drive use 3-Wire initialization. Failure to comply could result in death or serious injury from moving equipment.

■ H2-01 to H2-03: Terminal M1-M2, M3-M4, and MD-ME-MF Function Selection

The drive has three multi-function output terminals. [Table 4.13](#) lists the functions available for these terminals using H2-01, H2-02, and H2-03.

No.	Parameter Name	Setting Range	Default
H2-01	Terminal M1-M2 Function Selection (relay)	0 to 1AC	37: During Frequency Output
H2-02	Terminal M3-M4 Function Selection (relay)	0 to 1AC	42: Pressure Reached
H2-03	Terminal MD-ME-MF Function Selection (relay)	0 to 1AC	E: Fault

Table 4.13 Multi-Function Digital Output Terminal Settings

Setting	Function	Page	Setting	Function	Page
0	During run	–	42	Pressure Reached	178
1	Zero speed	–	43	2 Motor Alternate	–
2	Speed agree 1	–	4C	During fast stop	–
3	User-set speed agree 1	–	4D	oH Pre-alarm time limit	–
4	Frequency detection 1	–	4E	Braking transistor fault (rr)	–
5	Frequency detection 2	–	4F	Braking resistor overheat (oH)	–
6	Drive ready	–	51	Sequence timer 1	–
7	DC bus undervoltage	–	52	Sequence timer 2	–
8	During baseblock (N.O.)	–	53	Sequence timer 3	–
9	Frequency reference source	–	54	Sequence timer 4	–
A	HAND Mode	–	58	Underload detection	–
B	Torque detection 1 (N.O.)	–	60	Internal cooling fan alarm	–
C	Frequency reference loss	–	71	Secondary PI Feedback Low	–
D	Braking resistor fault	–	72	Secondary PI Feedback High	–
E	Fault	–	80	Pump 2 Control	–
F	Through mode	–	81	Pump 3 Control	–
10	Minor fault	–	82	Pump 4 Control	–
11	Fault reset command active	–	83	Pump 5 Control	–
12	Timer output	–	84	Pump 6 Control	–
13	Speed agree 2	–	89	Output 1 Limit	–
14	User-set speed agree 2	–	8B	Lube Pump or Digital Output Delay	–
15	Frequency detection 3	–	8F	Internal Fan On	–
16	Frequency detection 4	–	91	Pump Fault	–
17	Torque detection 1 (N.C.)	–	92	Transducer Loss	–
18	Torque detection 2 (N.O.)	–	93	Setpoint Not Met	–
19	Torque detection 2 (N.C.)	–	94	Loss of Prime	–
1A	During reverse	–	95	Volute Thermostat Fault	–
1B	During baseblock (N.C.)	–	96	High Feedback	–
1E	Restart enabled	–	97	Low Feedback	–
1F	Motor overload alarm (oL1)	–	98	Low Flow	–
20	Drive overheat pre-alarm (oH)	–	99	Accum Level	–
2F	Maintenance period	–	9A	High Flow	–
30	During torque limit	178	9B	Low Water Level	–
37	During frequency output	–	9C	Low Suction	–
38	Drive enabled	–	9D	High Suction	–
39	Watt hour pulse output	–	9E	Low PI Aux Level	–
40	Auto Mode	–	9F	High PI Aux Level	–
3D	During speed search	–	A0	Water Loss/Suction Pressure/PI Aux Control	–
3E	PID feedback low	–	A1	Differential Detected	–
3F	PID feedback high	–	A2	Sleep Active	–
40	Auto Mode	–	A3	Start Delay	–

4.7 Basic U1000 iQpump Setup and Application Preset Parameters

Setting	Function	Page	Setting	Function	Page
A4	Pre-Charge	–	AA	Utility Start Delay	–
A5	Anti-Jam Active	–	AB	Main FdBk Lost	–
A6	De-Scale Active	–	AC	Backup FdBk Lost	–
A7	Flow Rate Limit		100 to 1AC	Function 0 to AC with inverse output	–
A9	Thrust Mode	–			

Setting 30: During Torque Limit

The output closes when the motor is operating at the torque limit specified by the L7-□□ parameters or an analog input. This setting can only be used in OLV control mode.

Setting 42: Pressure Reached

Pressure Setpoint has been reached. Activation and deactivation conditions based on the Pressure Feedback and the settings of P4-36 to P4-40.

Direct-acting PID

The terminal activates when the feedback meets or exceeds the setpoint for the time set in P4-38.

The terminal deactivates based on the hysteresis level (P4-37), delay time (P4-39), and the pressure reached exit conditions (P4-36).

When P4-36 = 0 (Hysteresis Above & Below), the terminal deactivates when the feedback falls below the setpoint – hysteresis level or when it rises above the setpoint + hysteresis level for the time set in P4-39.

When P4-36 = 1 (Hysteresis 1-Way), the terminal only deactivates when the feedback falls below the setpoint – hysteresis level for the time set in P4-39.

Inverse-acting PID

The terminal activates when the feedback meets or falls below the setpoint for the time set in P4-20.

The terminal deactivates based on the hysteresis level (P4-37), delay time (P4-39), and the pressure reached exit conditions (P4-36).

When P4-36 = 0 (Hysteresis Above & Below), the terminal deactivates when the feedback falls below the setpoint – hysteresis level or when it rises above the setpoint + hysteresis level for the time set in P4-39.

When P4-36 = 1 (Hysteresis 1-Way), the terminal only deactivates when the feedback rises above the setpoint + hysteresis level for the time set in P4-39.

■ H3-01: Terminal A1 Signal Level Selection

Selects the input signal level for analog input A1.

No.	Name	Setting Range	Default
H3-01	Terminal A1 Signal Level Selection	0 to 3	0

Setting 0: 0 to 10 Vdc

The input level is 0 to 10 Vdc. The minimum input level is limited to 0%, so that a negative input signal due to gain and bias settings will be read as 0%.

Setting 1: 0 to 10 Vdc Bipolar

The input level is -10 to 10 Vdc. If the resulting voltage is negative after being adjusted by gain and bias settings, then the motor will rotate in reverse.

Setting 2: 4 to 20 mA

Setting 3: 0 to 20 mA

■ H3-02: Terminal A1 Function Selection

Selects the input signal level for analog input A1.

No.	Name	Setting Range	Default
H3-02	Terminal A1 Function Selection	0 to 26	0

■ H3-03, H3-04: Terminal A1 Gain and Bias Settings

Parameter H3-03 sets the level of the selected input value that is equal to 10 Vdc input at terminal A1 (gain).

Parameter H3-04 sets the level of the selected input value that is equal to 0 V input at terminal A1 (bias).

Use both parameters to adjust the characteristics of the analog input signal to terminal A1.

No.	Name	Setting Range	Default
H3-03	Terminal A1 Gain Setting	-999.9 to 999.9%	100.0%
H3-04	Terminal A1 Bias Setting	-999.9 to 999.9%	0.0%

Setting Examples

- Gain H3-03 = 200%, bias H3-04 = 0, terminal A1 as frequency reference input (H3-02 = 0):

A 10 Vdc input is equivalent to a 200% frequency reference and 5 Vdc is equivalent to a 100% frequency reference. Since the drive output is limited by the maximum frequency parameter (E1-04), the frequency reference will be equal to E1-04 above 5 Vdc.

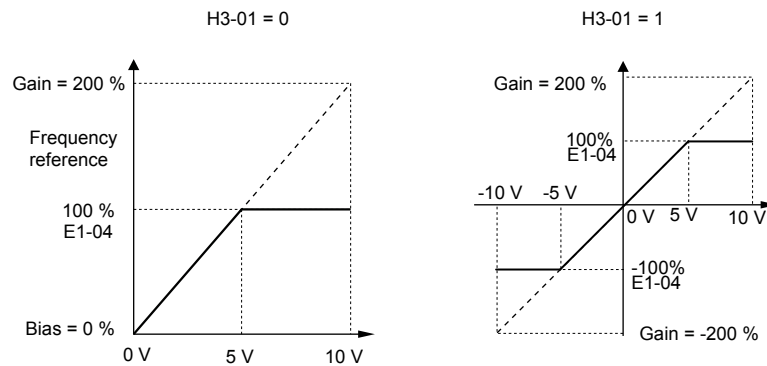

Figure 4.27 Frequency Reference Setting by Analog Input with Increased Gain

- Gain H3-03 = 100%, bias H3-04 = -25%, terminal A1 as frequency reference input:

An input of 0 Vdc will be equivalent to a -25% frequency reference.

When parameter H3-01 = 0, the frequency reference is 0% between 0 and 2 Vdc input.

When parameter H3-01 = 1, the motor will rotate in reverse between -10 and 2 Vdc input.

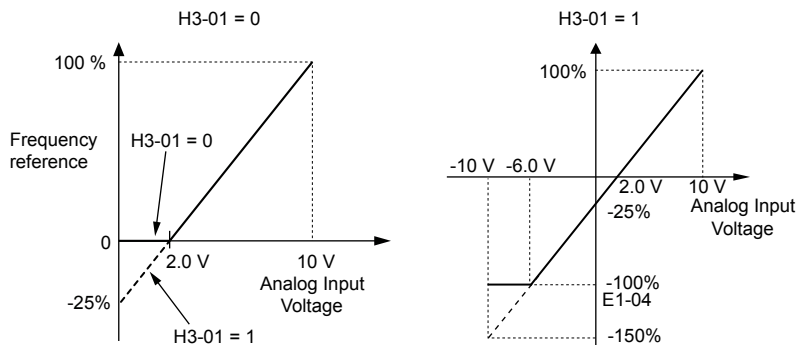

Figure 4.28 Frequency Reference Setting by Analog Input with Negative Bias

■ H3-05: Terminal A3 Signal Level Selection

Determines the function assigned to analog input terminal A3.

No.	Name	Setting Range	Default
H3-05	Terminal A3 Signal Level Selection	0 to 3	0

Setting 0: 0 to 10 Vdc

The input level is 0 to 10 Vdc. See the explanation provided for H3-01. *Refer to Setting 0: 0 to 10 Vdc on page 178.*

4.7 Basic U1000 iQpump Setup and Application Preset Parameters

Setting 1: 0 to 10 Vdc Bipolar

The input level is -10 to 10 Vdc. See the explanation provided for H3-01. [Refer to Setting 1: 0 to 10 Vdc Bipolar on page 178.](#)

Setting 2: 4 to 20 mA

Setting 3: 0 to 20 mA

■ H3-06: Terminal A3 Function Selection

Determines the function assigned to analog input terminal A3.

No.	Name	Setting Range	Default
H3-06	Terminal A3 Function Selection	0 to 32	20

■ H3-07, H3-08: Terminal A3 Gain and Bias Setting

Parameter H3-07 sets the level of the selected input value that is equal to 10 Vdc input at terminal A3 (gain).

Parameter H3-08 sets the level of the selected input value that is equal to 0 V input at terminal A3 (bias).

No.	Name	Setting Range	Default
H3-07	Terminal A3 Gain Setting	-999.9 to 999.9%	100.0%
H3-08	Terminal A3 Bias Setting	-999.9 to 999.9%	0.0%

■ H3-09: Terminal A2 Signal Level Selection

Selects the input signal level for analog input A2. Set Jumper S1 on the terminal board accordingly for a voltage input or current input.

No.	Name	Setting Range	Default
H3-09	Terminal A2 Signal Level Selection	0 to 3	2

Setting 0: 0 to 10 Vdc

The input level is 0 to 10 Vdc. [Refer to Setting 0: 0 to 10 Vdc on page 178.](#)

Setting 1: 0 to 10 Vdc Bipolar

The input level is -10 to 10 Vdc. [Refer to Setting 1: 0 to 10 Vdc Bipolar on page 178.](#)

Setting 2: 4 to 20 mA

The input level is 4 to 20 mA. Negative input values by negative bias or gain settings will be limited to 0%.

Setting 3: 0 to 20 mA

The input level is 0 to 20 mA. Negative input values by negative bias or gain settings will be limited to 0%.

■ H3-10: Terminal A2 Function Selection

Determines the function assigned to analog input terminal A2.

No.	Name	Setting Range	Default
H3-10	Terminal A2 Function Selection	0 to 32	B

■ H3-11, H3-12: Terminal A2 Gain and Bias Setting

Parameter H3-11 sets the level of the input value selected that is equal to 10 Vdc input or 20 mA input to terminal A2.

Parameter H3-12 sets the level of the input value selected that is equal to 0 V, 4 mA or 0 mA input at terminal A2.

Use both parameters to adjust the characteristics of the analog input signal to terminal A2. The setting works in the same way as parameters H3-03 and H3-04 for analog input A1.

No.	Name	Setting Range	Default
H3-11	Terminal A2 Gain Setting	-999.9 to 999.9%	100.0%
H3-12	Terminal A2 Bias Setting	-999.9 to 999.9%	0.0%

■ H4-01, H4-04: Multi-Function Analog Output Terminal FM, AM Monitor Selection

Sets the desired drive monitor parameter U□-□□ to output as an analog value via terminal FM and AM. *Refer to U1: Operation Status Monitors on page 397* for a list of all monitors. The “Analog Output Level” column indicates whether a monitor can be used for analog output.

Example: Enter “103” for U1-03.

No.	Name	Setting Range	Default
H4-01	Multi-Function Analog Output Terminal FM Monitor Selection	000 to 999	102
H4-04	Multi-Function Analog Output Terminal AM Monitor Selection	000 to 999	103

A setting of 031 or 000 applies no drive monitor to the analog output. With either of these settings, the output level of the terminals FM and AM can be set by a PLC via a communication option or MEMOBUS/Modbus (through mode).

**■ H4-02, H4-03: Multi-Function Analog Output Terminal FM Gain and Bias
H4-05, H4-06: Multi-Function Analog Output Terminal AM Gain and Bias**

Parameters H4-02 and H4-05 set the terminal FM and AM output signal level when the value of the selected monitor is at 100%. Parameters H4-03 and H4-06 set the terminal FM and AM output signal level when the value of the selected monitor is at 0%. Both are set as a percentage, where 100% equals 10 Vdc or 20 mA analog output and 0% equals 0 V or 4 mA. The output voltage of both terminals is limited to +/-10 Vdc.

The output signal range can be selected between 0 to +10 Vdc or -10 to +10 Vdc, or 4 to 20 mA using parameter H4-07 and H4-08. *Figure 4.29* illustrates how gain and bias settings work.

No.	Name	Setting Range	Default
H4-02	Multi-Function Analog Output Terminal FM Gain	-999.9 to 999.9%	100.0%
H4-03	Multi-Function Analog Output Terminal FM Bias	-999.9 to 999.9%	0.0%
H4-05	Multi-Function Analog Output Terminal AM Gain	-999.9 to 999.9%	50.0%
H4-06	Multi-Function Analog Output Terminal AM Bias	-999.9 to 999.9%	0.0%

Using Gain and Bias to Adjust Output Signal Level

The output signal is adjustable while the drive is stopped.

Terminal FM

1. View the value set to H4-02 (Terminal FM Monitor Gain) on the digital operator. A voltage equal to 100% of the parameter being set in H4-01 will be output from terminal FM.
2. Adjust H4-02 viewing the monitor connected to the terminal FM.
3. View the value set to H4-03 on the digital operator; terminal FM will output a voltage equal to 0% of the parameter being set in H4-01.
4. Adjust H4-03 viewing the output signal on the terminal FM.

Terminal AM

1. View the value set to H4-05 (Terminal AM Monitor Gain) on the digital operator. A voltage equal to 100% of the parameter being set in H4-04 will be output from terminal AM.
2. Adjust H4-05 viewing the monitor connected to the terminal AM.
3. View the value set to H4-06 on the digital operator; terminal AM will output a voltage equal to 0% of the parameter being set in H4-04.
4. Adjust H4-06 viewing the output signal on the terminal AM.

4.7 Basic U1000 iQpump Setup and Application Preset Parameters

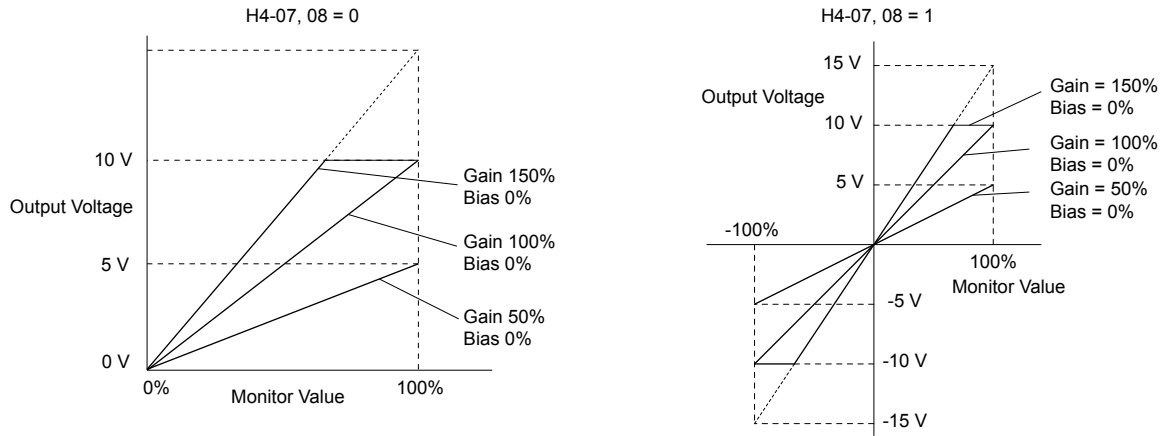

Figure 4.29 Analog Output Gain and Bias Setting Example 1 and 2

Set H4-03 to 30% for an output signal of 3 V at terminal FM when the monitored value is at 0%.

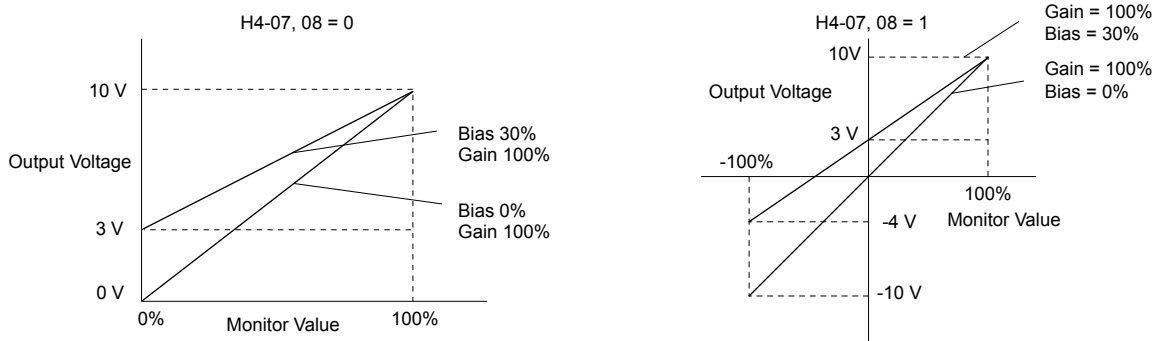

Figure 4.30 Analog Output Gain and Bias Setting Example 3

■ H4-07, H4-08: Multi-Function Analog Output Terminal FM, AM Signal Level Selection

Sets the voltage output level of U parameter (monitor parameter) data to terminal FM and terminal AM using parameters H4-07 and H4-08.

Set jumper S5 on the terminal board accordingly when changing these parameters. [Refer to Terminal AM/FM Signal Selection on page 106](#) for details on setting S5.

No.	Name	Setting Range	Default
H4-07	Multi-Function Analog Output Terminal FM Signal Level Selection	0 to 2	0
H4-08	Multi-Function Analog Output Terminal AM Signal Level Selection	0 to 2	0

Setting 0: 0 to 10 V

Setting 1: -10 V to 10 V

Setting 2: 4 to 20 mA

■ L5-01: Number of Auto Restart Attempts

Sets the number of times that the drive may attempt to restart itself.

When the counter reaches the number set to L5-01, the operation stops and the fault must be manually cleared and reset.

The restart counter is incremented at each restart attempt, regardless of whether the attempt was successful. When the counter reaches the number set to L5-01, the operation stops and the fault must be manually cleared and reset.

The number of fault restarts is reset to zero when:

- The drive operates normally for 10 minutes following a fault restart.
- A fault is cleared manually after protective functions are triggered.
- The power supply is cycled.

No.	Name	Setting Range	Default
L5-01	Number of Auto Restart Attempts	0 to 10 Times	5 Times

■ **L5-04: Fault Reset Interval Time**

Determines the amount of time to wait between restart attempts.

No.	Name	Setting Range	Default
L5-04	Fault Reset Interval Time10.0	10.0 to 3600.0 s	20.0 s

■ **o1-08: Third Line User Monitor Selection**

Selects the monitor that is shown in the third line. Effective only when o1-06 is set to 1.

Enter the last three digits of the monitor parameter number to be displayed: U□-□□. For example, set “403” to display monitor parameter U4-03.

No.	Name	Setting Range	Default
o1-08	Second Line User Monitor Selection	101 to 943	191

■ **P1-01: Pump Mode**

Selects the base operation mode of the drive controller.

No.	Parameter Name	Setting Range	Default
P1-01	Pump Mode	0, 1	0

Setting 0: Drive only

Designed for single pump stand-alone applications

Setting 1: Contactor lag

Contactor Lag systems multiplex a main pump with up to 5 lag pumps. The drive will stage and de-stage the lag pumps based on system demand by using its digital output contacts to control the lag pump motor starters

■ **P1-02: System Units**

Selects the base unit in which most drive PID setpoints, scaling, monitors, limits, and faults/alarm levels will be set.

Note: Set this parameter prior to changing other parameters, as internal scaling is based on P1-02.

No.	Parameter Name	Setting Range	Default
P1-02	System Units	0 to 11; 25, 26	1

Setting 0: No unit

Setting 1: PSI: Pounds per square inch

Setting 2: Pa: Pascals

Setting 3: Bar: Bar

Setting 4: "WC: Inch of water

Setting 5: "Hg: Inch of Mercury

Setting 6: ft: feet

Setting 7: m: meters

Setting 8: °F: Degrees Fahrenheit

Setting 9: °C: Degrees Celsius

Setting 10: Percent

Setting 11: kPA: kilopascal

Setting 25: Flow (Use P6-04)

Note: When using setting 25, the system units are set by parameter P6-04 and the PID feedback is rerouted to come from the flow meter, pulse input (H6-01 = 5), or analog (H3-0□ = 22).

Setting 26: Custom (P1-32 to P1-34)

This setting allows the user to create a custom system unit display with up to three characters. Use parameters P1-32 to P1-34 to make the custom system unit.

4.7 Basic U1000 iQpump Setup and Application Preset Parameters

The following are the selections available for custom system units:

Setting	Character	Setting	Character	Setting	Character	Setting	Character
20	SPACE	34	4	4F	O	69	I
21	!	35	5	50	P	6A	j
22	“	36	6	51	Q	6B	k
23	#	37	7	52	R	6C	l
24	\$	38	8	53	S	6D	m
25	%	39	9	54	T	6E	n
26	&	41	A	55	U	6F	o
27	'	42	B	56	V	70	p
28	(43	C	57	W	71	q
29)	44	D	58	X	72	r
2A	*	45	E	59	Y	73	s
2B	+	46	F	5A	Z	74	t
2C	,	47	G	61	a	75	u
2D	-	48	H	62	b	76	v
2E	.	49	I	63	c	77	w
2F	/	4A	J	64	d	78	x
30	0	4B	K	68	e	79	y
31	1	4C	L	66	f	7A	z
32	2	4D	M	67	g		
33	3	4E	N	68	h		

■ P1-03: Feedback Device Scaling

Sets the feedback device scaling used for the PID controller. This information can be found on the nameplate or specification sheet and is usually expressed as the maximum output of the device.

For example, a pressure sensor scaling might be 145.0 PSI at 20 mA output and would require setting P1-03 to 145.0 PSI.

Note: Set this parameter prior to changing other parameters related to the PID feedback, as internal scaling is based on P1-03.

No.	Parameter Name	Setting Range	Default
P1-03	Feedback Device Scaling	0.1 to 6000.0	145.0 PSI

■ P1-04: Start / Draw Down Level

Sets the wake up level from the Sleep function. This setting is dependent on whether PID is normal or inverse acting (b5-09). When the drive is asleep and the PID feedback signal rises above (normal acting) or falls below (inverse acting) this setting for the time set in P1-05, Start Level Delay Time, the drive will wake up.

This parameter activates the sleep function when the pump reaches the minimum pump speed set in P1-06 for the time set in P2-03.

No.	Parameter Name	Setting Range	Default
P1-04	Start / Draw Down Level	<>	0.0 PSI

<1> Range is 0.0 to 999.9 with sign-bit “-” or “+” indicating Delta to Setpoint.

■ P1-05: Start Level Delay Time

Sets the delay time for waking the drive to prevent accidental wake up caused by erratic feedback.

No.	Parameter Name	Setting Range	Default
P1-05	Start Level Delay Time	0 to 3600 s	1 s

■ P1-06: Minimum Pump Speed

Sets the minimum speed at which the drive will run the pump. Most pumps cannot run at low speeds due to cavitation, so be sure to consult the pump specification sheet for the minimum safe run speed.

4.7 Basic U1000 iQpump Setup and Application Preset Parameters

No.	Parameter Name	Setting Range	Default
P1-06	Minimum Pump Speed	0.0 to E1-04	40.0 Hz

Note: Unit range and resolution are determined by P1-07, Minimum Pump Speed Units. Setting P1-07 to 1 (RPM) will set a default value of 1800 RPM (VTC) and 2400 RPM (all others). Setting P1-07 to 0 Hz, (default) will set a default value of 40.0 Hz.

■ P1-07: Minimum Pump Speed Units

Sets the units for parameter P1-06. Changing P1-07 will reset P1-06 to the default value.

No.	Parameter Name	Setting Range	Default
P1-07	Minimum Pump Speed Units	0 to 1	0

■ P1-08: Low Feedback Level

Sets the level at which a Low Feedback alarm or fault will occur. When the PID feedback falls below the P1-08 setting for the time set in P1-09, the drive will respond based on the setting in P1-10.

No.	Parameter Name	Setting Range	Default
P1-08	Low Feedback Level	<1>	0.0 PSI

<1> Range is 0.0 to 999.9 with sign-bit “-” indicating Delta to Setpoint.
Range is 0.0 to 6000.0 in drive software versions PRG: 8551 and earlier.

■ P1-09: Low Feedback Level Fault Delay Time

Sets the delay time after which a Low Feedback alarm or fault will occur. When the PID feedback falls below the P1-08 setting for the time set in P1-09, the drive will respond based on the setting in P1-10.

No.	Parameter Name	Setting Range	Default
P1-09	Low Feedback Level Fault Delay Time	0 to 3600 s	10 s

■ P1-10: Low Feedback Selection

Selects the drive response to a Low Feedback condition. When the PID feedback falls below the P1-08 setting for the time set in P1-09, the drive will respond based on the setting in P1-10.

No.	Parameter Name	Setting Range	Default
P1-10	Low Feedback Selection	0 to 2	0

Low feedback detection is enabled when:

- P1-08 > 0.0
- Drive is running in AUTO Mode, including sleep boost and feedback drop detection (standard PID, b5-09 = 0)
- Run Command is present (including sleep and timer operation) (inverse PID, b5-09 = 1)

Setting 0: Fault

When feedback drops below the P1-08 level for longer than the time set in P1-09, the drive will fault on the “LFB – Low Feedback” fault and coast to a stop.

The digital output programmed to “Low Feedback” (H2-0□ = 97) closes. The drive will also display the “Low Feedback – Low FB Sensed” alarm. The digital output will remain closed until the fault is reset.

Setting 1: Alarm

When feedback drops below the P1-08 level for longer than the time set in P1-09, the digital output programmed to “Low Feedback” (H2-0□ = 97) closes and the drive displays the “Low Feedback – Low FB Sensed” alarm.

When feedback rises above the level determined by P1-08 and P1-14, or when one or more of the conditions that enable low feedback detection are no longer true, the digital output will open and the alarm will clear.

Setting 2: Digital out only

When feedback drops below the P1-08 level for longer than the time set in P1-09, the digital output programmed to “Low Feedback” (H2-0□ = 97) closes.

When feedback rises above the level determined by P1-08 and P1-14, or when one or more of the conditions that enable low feedback detection are no longer true, the digital output will open.

4.7 Basic U1000 iQpump Setup and Application Preset Parameters

■ P1-11: High Feedback Level

Sets the level at which a High Feedback alarm or fault will occur. When the PID feedback rises above the P1-11 setting for the time set in P1-12, the drive will respond based on the setting in P1-13.

No.	Parameter Name	Setting Range	Default
P1-11	High Feedback Level	</>	155.0 PSI

<1> Range is 0.0 to 999.9 with sign-bit “+” indicating Delta to Setpoint.

■ P1-12: High Feedback Level Fault Delay Time

Sets the delay time after which a Low Feedback alarm or fault will occur. When the PID feedback rises above the P1-11 setting for the time set in P1-12, the drive will respond based on the setting in P1-13.

No.	Parameter Name	Setting Range	Default
P1-12	High Feedback Level Fault Delay Time	0 to 3600 s	5 s

■ P1-13: High Feedback Selection

Selects the drive response to a High Feedback condition. When the PID feedback rises above the P1-11 setting for the time set in P1-12, the drive will respond based on the setting in P1-13.

No.	Parameter Name	Setting Range	Default
P1-13	High Feedback Selection	0 to 2	0

High feedback detection is enabled when:

- P1-11 > 0
- Run Command present, including sleep & timer operation (standard PID, b5-09 = 0)
- Drive is running in AUTO Mode, including feedback drop detection (inverse PID, b5-09 = 1).

Setting 0: Fault

When feedback rises above the P1-11 for longer than the time set in P1-12, the drive will fault on the “HFB – High Feedback” fault and coast to a stop.

The digital output programmed to “High Feedback” (H2-0□= 96) closes. The drive will also display the “High Feedback – High FB Sensed” alarm. The digital output will remain closed until the fault is reset.

Setting 1: Alarm

When feedback rises above the P1-11 for longer than the time set in P1-12, the digital output programmed to “High Feedback” (H2-0□= 96) closes and the drive displays the “High Feedback – High FB Sensed” alarm.

When feedback falls below the level determined by P1-11 and P1-14, or when one or more of the conditions that enable high feedback detection are no longer true, the digital output will open and the alarm will clear.

Setting 2: Digital out only

When feedback rises above the P1-11 for longer than the time set in P1-12, the digital output programmed to “High Feedback” (H2-0□= 96) closes.

When feedback falls below the level determined by P1-11 and P1-14, or when one or more of the conditions that enable high feedback detection are no longer true, the digital output will open.

■ P1-40: Maximum Pump Speed

Sets the maximum pump speed determined by the smallest value among P1-40, E1-04, and d2-01. This parameter is not effective when set to 0 or when set higher than E1-04 x d2-01.

When this parameter ≠ 0, maximum pump speed is internally lower limited to the minimum pump speed (largest setting among P1-06, P4-12, and d2-02).

- Note:**
1. Parameter available in drive software versions PRG: 8552 and later.
 2. Parameter not available in drive models 4A0930 and 4A1200.

No.	Parameter Name	Setting Range	Default
P1-40	Maximum Pump Speed	0.0 to 440.0 Hz	0.0 Hz

■ P2-01: Sleep Level Type

Selects which data source the drive will use to determine if it should activate the sleep function. This parameter is application-dependent and should be set in conjunction with the type of system data is available. Choose the data type that best represents a low-activity condition for the system.

Note: Set this parameter prior to changing other parameters related to the Sleep Function, as internal scaling is based on P2-01.

No.	Parameter Name	Setting Range	Default
P2-01	Sleep Level Type	0 to 4	0

Setting 0: Output frequency

Setting 1: Output current

Setting 2: Feedback

Setting 3: Output speed (RPM)

Setting 4: Flow meter (requires flow meter)

■ P2-02: Sleep Level

Sets the level at which the drive will enter sleep mode. The drive will enter sleep mode when the monitored data falls below the P2-02 setting for the time set in P2-03.

No.	Parameter Name	Setting Range	Default
P2-02	Sleep Level	0.0 to 6000.0	0.0 Hz

Note: Units will be determined by P1-02 setting when P2-01 = 2.

■ P2-03: Sleep Delay Time

Sets the delay time after which the drive will enter sleep mode. The drive will enter sleep mode when the monitored data falls below the P2-02 setting for the time set in P2-03.

No.	Parameter Name	Setting Range	Default
P2-03	Sleep Delay Time	0 to 3600 s	5 s

■ P2-15: Sleep AUTO → OFF

When enabled, Sleep is active even if the Start Level P1-04 is set to 0. In addition, the drive will switch to OFF mode when called to Sleep.

- Note:**
1. Parameter available in drive software versions PRG: 8552 and later.
 2. Parameter not available in drive models 4A0930 and 4A1200.

No.	Parameter Name	Setting Range	Default
P2-15	Sleep AUTO → OFF	0, 1	0

Setting 0: Disabled

Set P1-04 ≠ 0 to enable Sleep operation with this setting. When drive goes to sleep, output speed falls to 0 and the drive stays in Auto Mode.

Setting 1: Enabled

Sleep operation is enabled regardless of P1-04 value for this setting. When the drive calls for Sleep, the mode switches from AUTO to OFF and the drive displays the Sleep AUTO->Off message.

Press any key, run the drive in AUTO, HAND, or JOG to dismiss the message. Issue the AUTO command to run the drive again.

■ P3-00: Number of Lag Pumps

Sets the number of lag pumps in the system. When using Contactor Multiplexing for the control lag pumps, first set P1-01 to 1. Then select the number of lag pumps to be controlled in P3-00. Set the corresponding multi-function digital outputs for lag pumps (H2-□□ = 80-82 and F5-□□ = 83-84). The methods used to determine lag pump staging and de-staging order are selected in P1-30 and P1-31.

No.	Parameter Name	Setting Range	Default
P3-00	Number of Lag Pumps	1 to 5	1

4.7 Basic U1000 iQpump Setup and Application Preset Parameters

■ P3-50: Pump 2 Frequency Shutdown Level

Sets the level at which the first lag pump (2nd pump in the system) will shut down or de-stage. This parameter is effective when the P3-01 is set to 0 or 2 (pump staging is based on output frequency). When the output frequency falls below the P3-50 level for the time set in P3-09, the pump will be de-staged.

No.	Parameter Name	Setting Range	Default
P3-50	Pump 2 Frequency Shutdown Level	0.0 to 400.0	40.0 Hz

■ P3-60: Pump 3 Frequency Shutdown Level

Sets the level at which the second lag pump (3rd pump in the system) will shut down or de-stage. This parameter is effective when the P3-01 is set to 0 or 2 (pump staging is based on output frequency). When the output frequency falls below the P3-50 level for the time set in P3-09, the pump will be de-staged.

No.	Parameter Name	Setting Range	Default
P3-60	Pump 3 Frequency Shutdown Level	0.0 to 400.0	40.0 Hz

■ P3-70: Pump 4 Frequency Shutdown Level

Sets the level at which the third lag pump (4th pump in the system) will shut down or de-stage. This parameter is effective when the P3-01 is set to 0 or 2 (pump staging is based on output frequency). When the output frequency falls below the P3-50 level for the time set in P3-09, the pump will be de-staged.

No.	Parameter Name	Setting Range	Default
P3-70	Pump 4 Frequency Shutdown Level	0.0 to 400.0	40.0 Hz

■ P3-80: Pump 5 Frequency Shutdown Level

Sets the level at which the third lag pump (5th pump in the system) will shut down or de-stage. This parameter is effective when the P3-01 is set to 0 or 2 (pump staging is based on output frequency). When the output frequency falls below the P3-50 level for the time set in P3-09, the pump will be de-staged.

No.	Parameter Name	Setting Range	Default
P3-80	Pump 5 Frequency Shutdown Level	0.0 to 400.0	40.0 Hz

■ P3-90: Pump 6 Frequency Shutdown Level

Sets the level at which the third lag pump (6th pump in the system) will shut down or de-stage. This parameter is effective when the P3-01 is set to 0 or 2 (pump staging is based on output frequency). When the output frequency falls below the P3-50 level for the time set in P3-09, the pump will be de-staged.

No.	Parameter Name	Setting Range	Default
P3-90	Pump 6 Frequency Shutdown Level	0.0 to 400.0	40.0 Hz

■ P4-01: Pre-Charge Level

Sets the level at which the drive will activate the pre-charge function. At start, if the PID is below the P4-01 setting, the drive will run at the P4-02 frequency setting for the time set in P4-03. PID control is delayed until the pre-charge function stops. The drive will exit the pre-charge function early if the feedback rises above the P4-01 setting or if a Low Water digital input switch (H1-□□ = 8F) deactivates. Pre-charge is useful to slowly fill or pressurize a system.

No.	Parameter Name	Setting Range	Default
P4-01	Pre-Charge Level	0.0 to 6000.0	0.0 </>

<1> Units determined by P1-02 setting.

■ P4-02: Pre-Charge Frequency

Sets the frequency at which the pre-charge function will run.

No.	Parameter Name	Setting Range	Default
P4-02	Pre-Charge Frequency	0.0 to E1-04	0.0 Hz

■ P4-03: Pre-Charge Time

Sets the duration of time that the pre-charge function will run.

No.	Parameter Name	Setting Range	Default
P4-03	Pre-Charge Time	0.0 to 3600.0 min	0.0 min

The following conditions must be met to enter Pre-Charge Mode:

- Drive Ready or Sleeping (Run command, not faulted, not in program mode)
- NOT in HAND Mode
- “Disable Pre-Charge” digital input NOT closed
- P4-03 > 0.0
- If P4-01, Pre-Charge Level, is greater than 0, the PID feedback must be below the P4-01 level. (Forward acting PID, b5-09 = 0, Reverse acting PID, b5-09 = 1).

When the drive enters Pre-Charge Mode 1 and 2, the drive runs at the Pre-Charge frequency set in P4-02/P4-06, the PID controller is disabled and the Pre-Charge digital output (H2-0□ = A4) closes.

When pre-charge is active, the message “Pre Chg Mode Exit in Xsec” appears on the keypad to show how long before pre-charge exits via timers (P4-03 + P4-07).

Additionally, during Pre-Charge Mode:

- When Pre-Charge Level 2 (P4-32) is set to 0, the system can exit Pre-Charge when the PID Feedback goes above the Pre-Charge Level (P4-01) in normal PID operation, or below the P4-01 level in inverse PID operation.

However, when Pre-Charge Level 2 (P4-32) is set to a non-zero value, the system goes into Pre-Charge 2 instead when Pre-Charge 1 completes via timer (P4-03) or level (P4-01). At this point, the drive will run at Pre-Charge Frequency 2 (P4-06).

The system can exit Pre-Charge 2 when the PID Feedback goes above the Pre-Charge Level 2 (P4-32) in normal PID operation, or below the P4-32 level in inverse operation. Refer to [Figure 4.31](#) and [Figure 4.32](#) for more information.

- When P4-02, Pre-Charge Frequency, or P4-06, Pre-Charge Frequency 2, are set to a value less than P1-06, Minimum Pump Speed, the alarm “Freq. Ref < Pump Min P1-06” is displayed and the drive runs at the minimum speed.
- When Pre-Charge Loss of Prime parameters P4-05 and P4-08 are set to 0, the Loss of Prime detection is disabled.
- When Pre-Charge Loss of Prime parameters P4-05 or P4-08 are set to a value greater than 0, Loss of Prime detection will operate after the output speed reaches the Pre-Charge Frequency set in P4-02 or P4-06.
- The “Low Water” fault (H1-0□ = 8F) is disabled.
- The “Low Feedback” fault is disabled when forward-acting PID is selected (b5-09 = 0) and the “High Feedback” fault is disabled when reverse-acting PID is selected (b5-09 = 1).
- The “Not Maintaining Setpoint” fault is disabled.
- The “Feedback Loss” detection (4 to 20 mA wire break) is enabled, however, the Pre-Charge frequencies will override and the b5-13 “feedback loss goto speed”.

The drive will always exit Pre-Charge Mode when Pre-Charge times P4-03 and P4-07 have expired. The drive will also exit Pre-Charge Mode when one of the following conditions are met:

- P4-03 and P4-32 are set to 0.0
- The “Disable Pre-Charge” digital input (H1-0□ = 8C) closes.
- A digital input programmed to “Low Water” (H1-0□ = 8F) is deactivated (open when P1-30 = 0 or closed when P1-30 = 1).
- The PID feedback satisfies both Pre-Charge levels 1 and 2 (all must be true):

Pre-Charge timers P4-03 and P4-07 have NOT expired

PID is enabled (b5-01 > 0).

PID is NOT disabled via digital input

Pre-Charge Level Set (P4-01 > 0) (and if used, P4-32 > 0)

Feedback is greater than Pre-Charge Level (P4-01) and Pre-Charge Level 2 (P4-32) (forward-acting PID, b5-09 = 0) or less than Pre-Charge Levels 1 and 2 (reverse-acting PID, b5-09 = 1)

Drive is NOT in a “Feedback Loss” condition (4 to 20 mA wire-break detection).

4.7 Basic U1000 iQpump Setup and Application Preset Parameters

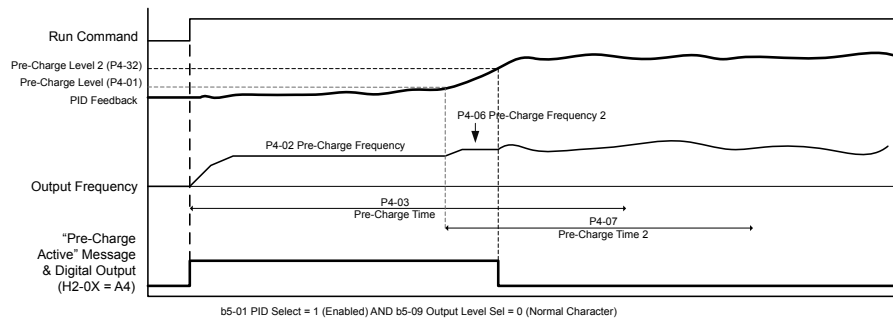

Figure 4.31 Pre-Charge 1 and 2 Complete via PID Feedback

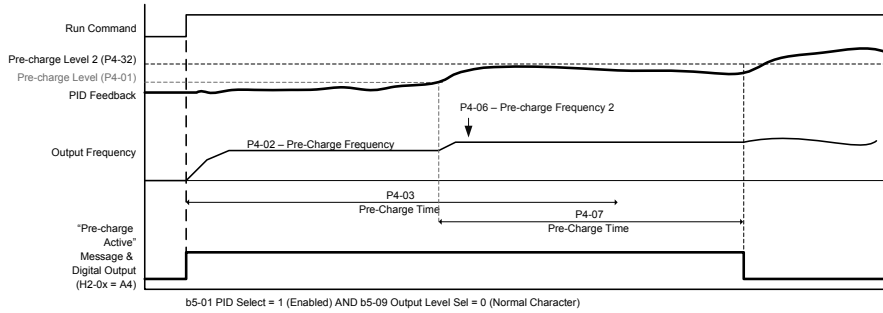

Figure 4.32 Pre-Charge 1 Complete via PID Feedback & Pre-Charge 2 via Timer

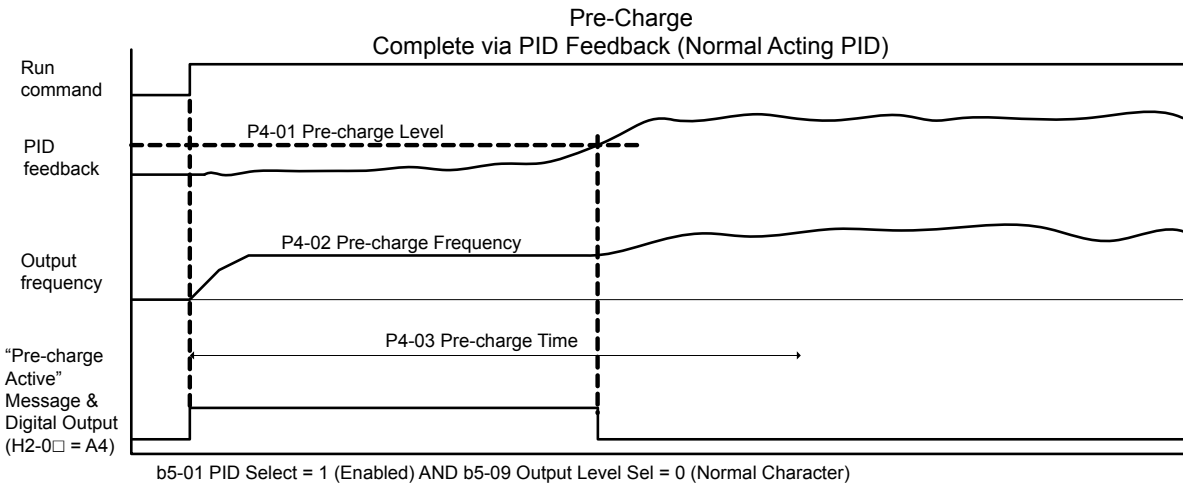

Figure 4.33 Pre-Charge Normal Acting PID

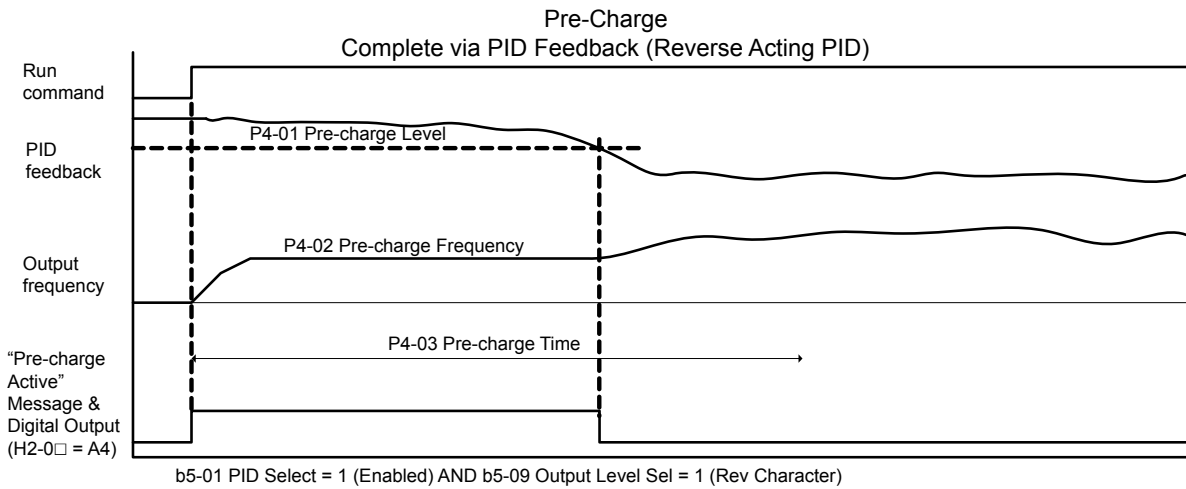

Figure 4.34 Pre-Charge Inverse Acting PID

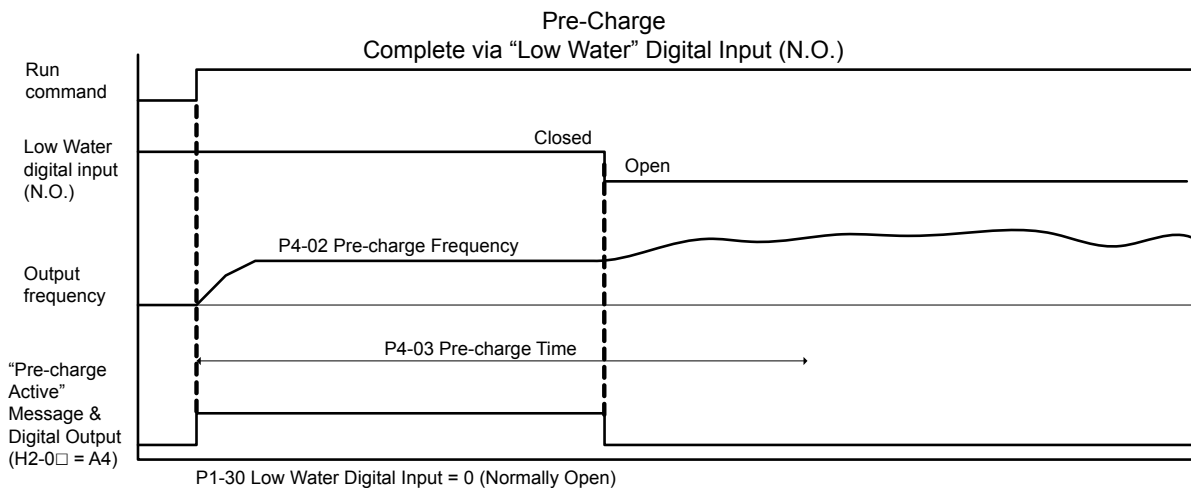

Figure 4.35 Pre-Charge via Low Water DI

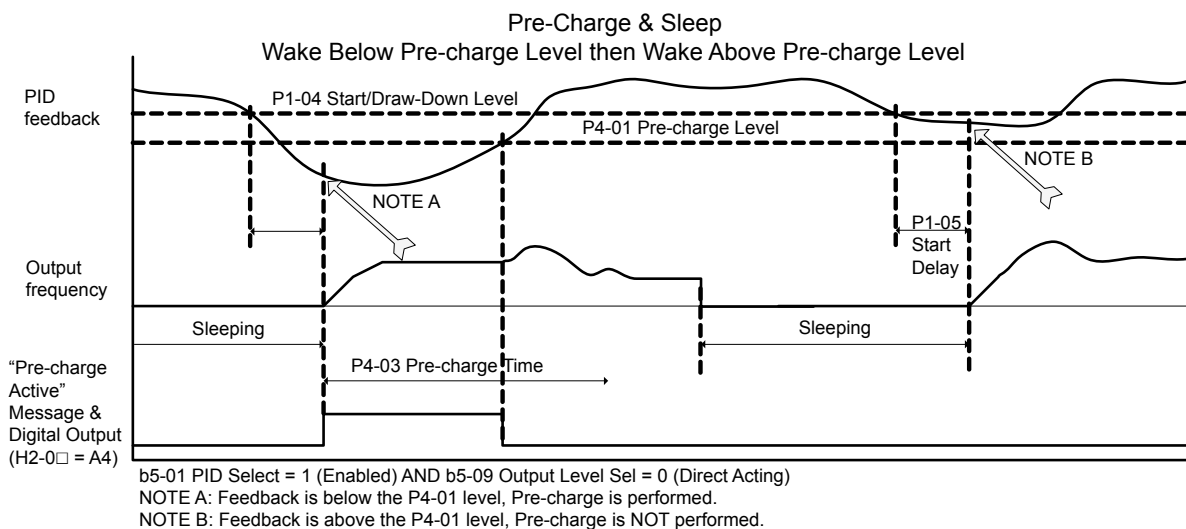

Figure 4.36 Pre-Charge and Sleep

■ P4-04: Pre-Charge Message Style

Selects how the “Pre-Charge Active” message is displayed on the operator.

4.7 Basic U1000 iQpump Setup and Application Preset Parameters

No.	Parameter Name	Setting Range	Default
P4-04	Pre-Charge Message Style	0, 1	0

Setting 0: Full Screen Message

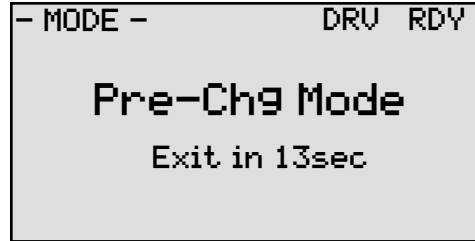

Setting 1: Home Monitor Text

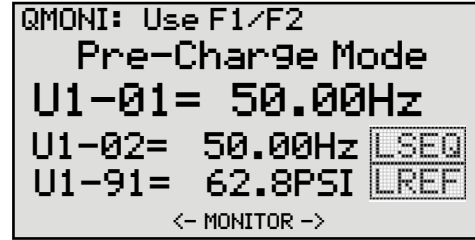

■ P4-10: AUTO Mode Operator Run Power Down Storage

Selects drive response to power loss with regards to the Run command. When running in AUTO Mode and using a Run command from the keypad (b1-02 = 0), P4-10 determines whether the drive will automatically start running when power is reapplied. The factory setting of this parameter requires pressing the AUTO key to start the drive after power loss.

WARNING! Sudden Movement Hazard. If the drive is running at power loss, it will automatically initiate an internal Run command upon power-up if P4-10 = 1 (Enabled) and could result in death or serious injury from moving equipment.

No.	Parameter Name	Setting Range	Default
P4-10	AUTO Mode Operator Run Power Down Storage	0, 1	0

Setting 0: Disabled

Setting 1: Enabled

■ P4-12: Thrust Bearing Frequency

Sets the frequency used by the drive when determining which acceleration and deceleration time to use. The Thrust Bearing function is used for applications using submersible motors. The function provides an alternate acceleration time (P4-11) and deceleration time (P4-13) for protecting the pump bearings.

At start, the drive will use the P4-11 acceleration time until the P4-12 frequency is reached, at which time it will use the active C1-□□ acceleration and deceleration times. At stop, if the output frequency is above the P4-12 setting, the active C1-□□ deceleration time will be used until the P4-12 setting is reached at which time it will use the P4-13 time setting for the rest of deceleration.

If P4-12 is set greater than P1-06 (minimum Pump Speed), P4-12 will become the frequency lower limit. The drive PID control must be disabled (b5-01 = 0) for this function to work.

No.	Parameter Name	Setting Range	Default
P4-12	Thrust Bearing Frequency	0.0 to E1-04	30.0 Hz

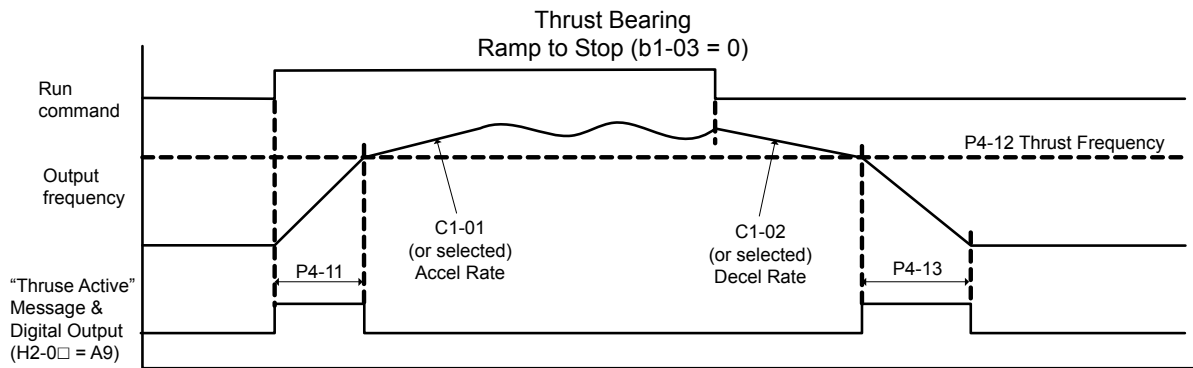

Figure 4.37 Thrust Bearing

■ **P4-17: Utility Start Delay**

Sets the delay time after power up until the drive will recognize a Run command present within one second of power up or when the Run command is jumpered on the terminal strip.

This is useful in preventing a peak power surge when multiple drives power up and begin accelerating simultaneously. This function works when the drives all have different P4-17 settings to spread out the power draw during acceleration.

If the Run command is removed and reapplied during the P4-17 time, the drive will cancel the utility start delay and immediately begin running.

The Utility Start Delay is applied when the drive is auto-restarting after an Undervoltage (Uv), Overvoltage (ov), Power Supply Over Voltage (Aov), Power Supply Undervoltage (AUv) or a Power Supply Frequency Fault (Fdv) condition.

No.	Parameter Name	Setting Range	Default
P4-17	Utility Start Delay	0.0 to 1000.0 min	0.2 min

■ **P4-40: Pressure Reached Detection Selection**

Sets the drive state that must be met when triggering the Pressure Detection digital output.

No.	Parameter Name	Setting Range	Default
P4-40	Pressure Reached Detection Selection	0 to 2	0

Setting 0: Always

Triggers the digital output regardless of drive status (even when the drive is stopped or sleeping).

Setting 1: Drive Running

Triggers the digital output if the drive is producing output voltage (not baseblocked) to the motor. The digital output will not engage when the drive is sleeping.

Setting 2: Run Command

Triggers the digital output when there is an active Run command.

■ **P5-02: HAND Reference 1**

Sets the frequency reference of HAND mode. When the drive is stopped, pressing the HAND key will start the drive and the drive will accelerate to the P5-02 setting.

No.	Parameter Name	Setting Range	Default
P5-02	HAND Reference 1	0.0 to E1-04	40.0 Hz

■ **P5-04: HAND Key Function Selection**

Selects whether the HAND key on the HOA keypad is active. Disabling this function by setting P5-04 to 0 will prevent the drive from entering HAND Mode.

No.	Parameter Name	Setting Range	Default
P5-04	HAND Key Function Selection	0, 1	1

4.7 Basic U1000 iQpump Setup and Application Preset Parameters

Setting 0: Disabled

Setting 1: Enabled

■ P6-12: Accumulation Level - Thousands

Sets the accumulated volume that will trigger the Accum Level alarm, Accum Level fault, or the Accum Level Fault – Auto Flow Accum Reset.

No.	Name	Setting Range	Default
P6-12	Accumulation Level - Thousands	0 to 999	0 gal

■ P6-15: Accumulation Behavior

Selects the drive response when the accumulated volume reaches the level set in parameters P6-11 to P6-14.

No.	Name	Setting Range	Default
P6-15	Accumulation Behavior	0 to 5	1

Setting 0: No display

Setting 1: Alarm only

Setting 2: Fault

Setting 3: Fault - Auto flow accum reset

Setting 4: Stop and alarm

Setting 5: Stop, alarm, and reset flow accumulation

■ P6-17: High Flow Level

Sets the level above which the flow must rise for longer than the time set in P6-18 to trigger a High Flow fault or alarm.

A setting of 0.0 disables High Flow detection.

No.	Name	Setting Range	Default
P6-17	High Flow Level	0.0 to 6000.0	0.0 GPM

■ P6-19: High Flow Select

Determines drive response when a High Flow condition is detected.

No.	Name	Setting Range	Default
P6-19	High Flow Select	0 to 3	1

Setting 0: No display

Setting 1: Alarm only

Setting 2: Fault

Setting 3: Auto-restart (time set by L5-04)

■ P6-25: Flow Rate Limit Foldback Message Style

Selects how the “Flow Rate Limit Foldback” message is displayed on the operator.

No.	Parameter Name	Setting Range	Default
P6-25	Flow Rate Limit Foldback Message Style	0, 1	0

Setting 0: Full Screen Message

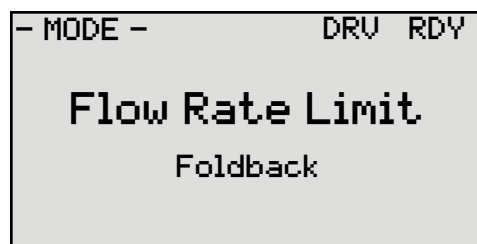

Setting 1: Home Monitor Text

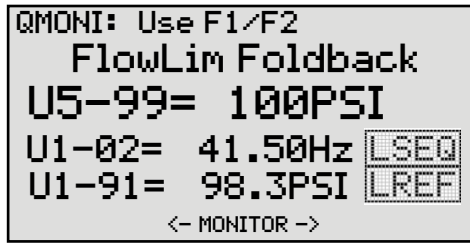

■ **Q1-01: PID Controller Setpoint 1**

Sets the PID setpoint for the controller. The drive will use the system feedback signal and modulate the pump speed to regulate the feedback at the Q1-01 setpoint. The units for Q1-01 are selected by b1-01 and the scaling is set in parameter P1-03. This parameter is active when b1-01 (Reference Source) is set to 0 (HOA keypad).

No.	Parameter Name	Setting Range	Default
Q1-01	PID Controller Setpoint 1	0.0 to 6000.0	0.0 PSI

■ **Q3-06: Current Limit Foldback Message Style**

Selects how the “Current Limit Foldback” message is displayed on the operator.

No.	Parameter Name	Setting Range	Default
Q3-06	Current Limit Foldback Message Style	0, 1	0

Setting 0: Full Screen Message

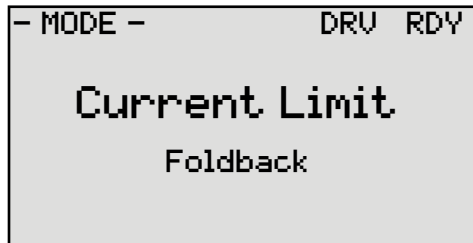

Setting 1: Home Monitor Text

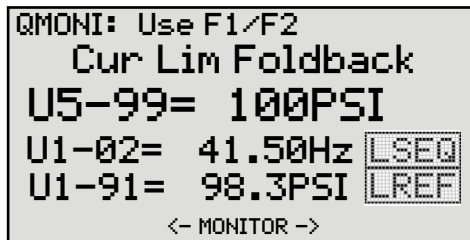

■ **Q5-03: Suction Pressure Setpoint**

Sets the Suction Pressure setpoint. The units of Q5-03 are selected in Q5-01 and the scaling is set in Q5-02 (Suction Transducer Scaling). The Suction Pressure function is enabled by setting Q5-01 = 1 (Suction Pressure). This function uses Q5-03 as the setpoint instead of Q1-01, and Q5-02 as the feedback scaling instead of P1-02. Set b5-01 to a value other than 0 to enable the drive PID controller and use this function.

This feature can be used to allow the drive to control (outlet) pressure when there is adequate pressure on the inlet side of the pump by setting Q5-01 to 1 (Suction Pressure). When the suction pressure (pump inlet pressure) drops to the Suction Pressure Setpoint (Q5-03), it will regulate the suction pressure and the outlet pressure will be allowed to drop. This requires both a suction pressure transducer on the pump inlet and a pressure feedback transducer on the pump output.

No.	Parameter Name	Setting Range	Default
Q5-03	Suction Pressure Setpoint	0.0 to 1200.0	20.0 PSI

4.7 Basic U1000 iQpump Setup and Application Preset Parameters

■ Q5-06: Wake-Up Suction Pressure

Sets the wake up level for the suction pressure control function. The drive falls asleep based on the Q5-04 level and Q5-05 delay time. The drive will wake up when the suction pressure feedback rises above the Q5-06 setting for the time set in Q5-07 AND the standard sleep function calls for a wake up (P1-04 and P1-05).

No.	Parameter Name	Setting Range	Default
Q5-06	Wake-Up Suction Pressure	0.0 to 1200.0	30.0 PSI

■ Q5-09: Low Suction Pressure Detection Level

Sets the level at which a Low Suction Pressure alarm or fault will occur.

For Q5-01 = 1 (Suction Pressure): If Q5-11 = 2 or 3, the drive will respond based on the Q5-11 setting when the suction pressure feedback falls below the Q5-09 setting for the time set in Q5-10. If Q5-11 = 0 or 1, the drive will respond based on the Q5-11 setting as soon as the suction pressure feedback falls below the Q5-09 setting.

For Q5-01 = 2 (Vacuum): If Q5-11 = 1, 2 or 3, the drive will respond based on the Q5-11 setting when the suction pressure feedback falls below the Q5-09 setting for the time set in Q5-10. If Q5-11 = 0, the 9Ch Low Suction MFDO will close as soon as the suction pressure feedback falls below the Q5-09 setting.

No.	Parameter Name	Setting Range	Default
Q5-09	Low Suction Pressure Detection Level	0.0 to 1200.0	0.0 PSI

■ Q5-10: Low Suction Pressure Detection Time

Sets the delay time after which a Low Suction Pressure alarm or fault will occur. When the suction pressure feedback falls below the Q5-09 setting for the time set in Q5-10, the drive will respond based on the setting in Q5-11.

No.	Parameter Name	Setting Range	Default
Q5-10	Low Suction Pressure Detection Time	0.0 to 300.0	0.1 min

■ Q5-11: Low Suction Pressure Behavior Select

Selects the drive response to a Low Suction Pressure condition. When the suction pressure feedback falls below the Q5-09 setting for the time set in Q5-10, the drive will respond based on the setting in Q5-11. By setting Q5-11 to 3 (Restart Q5-15), the drive will attempt to reset itself for the number of times set in L5-01 waiting for the Q5-15 reset time before each reset attempt. The drive will fault if the L5-01 attempts are exceeded.

Note: If Q5-01 = 1 (Suction Pressure), the Q5-10 detection delay time only applies to Q5-11 settings 2 and 3. If Q5-01 = 2 (Vacuum), the Q5-10 detection delay time applies to Q5-11 settings 1, 2, and 3.

No.	Parameter Name	Setting Range	Default
Q5-11	Low Suction Pressure Behavior Select	0 to 3	1

Setting 0: No display (digital output only)

Setting 1: Alarm only

Setting 2: Fault

Setting 3: Auto-restart (time set in Q5-15)

■ Q5-16: Suction Control Proportional Gain

Sets the proportional gain of the Suction Pressure controller. Increasing this value will make the system more responsive but can lead to instability. Q5-16 is used in place of b5-02 for suction pressure control.

No.	Parameter Name	Setting Range	Default
Q5-16	Suction Control Proportional Gain	0.00 to 25.00	2.00

■ Q5-17: Suction Control Integral Time

Sets the integral time of the Suction Pressure controller. Decreasing this value will make the system more responsive but can lead to overshoot. Q5-17 is used in place of b5-03 for suction pressure control.

No.	Parameter Name	Setting Range	Default
Q5-17	Suction Control Integral Time	0.0 to 360.0 s	5.0 s

■ Q6-23: PI Auxiliary Control

Determines whether the PI Auxiliary Controller is Direct-acting (feedback higher than setpoint results in lower speed) or Inverse-acting (feedback lower than setpoint results in lower speed).

No.	Parameter Name	Setting Range	Default
Q6-23	PI Auxiliary Control	0, 1	1

Setting 0: Direct Acting

When Q6-25 (PI Aux Control Activation Level) = 0, the PI Aux Controller can affect the output frequency if the controller’s output is less than the primary PID (System Pressure) controller’s output.

When Q6-25 (PI Aux Control Activation Level) > 0, the PI Aux Feedback Level (H3-□□ = 27) has to rise above the level set in Q6-25 for the time set in Q6-26 (PI Aux Control Activation Delay) before the PI Aux Controller is allowed to affect the output frequency.

When active, the PI Aux Feedback Level (H3-□□ = 27) has to drop below the Q6-25 level for the time set in Q6-26 before the PI Aux Controller is deactivated and not allowed to affect the output frequency.

Setting 1: Inverse Acting

When Q6-25 (PI Aux Control Activation Level) = 0, the PI Aux Controller can affect the output frequency if the controller’s output is less than the primary PID (System Pressure) controller’s output.

When Q6-25 (PI Aux Control Activation Level) > 0, the PI Aux Feedback Level (H3-□□ = 27) has to drop below the level set in Q6-25 for the time set in Q6-26 (PI Aux Control Activation Delay) before the PI Aux Controller is allowed to affect the output frequency.

When active, the PI Aux Feedback Level (H3-□□ = 27) has to rise above the Q6-25 level for the time set in Q6-26 before the PI Aux Controller is deactivated and not allowed to affect the output frequency.

The following are the selections available for custom system units:

Setting	Character	Setting	Character	Setting	Character	Setting	Character
20	SPACE	34	4	4F	O	69	I
21	!	35	5	50	P	6A	j
22	“	36	6	51	Q	6B	k
23	#	37	7	52	R	6C	l
24	\$	38	8	53	S	6D	m
25	%	39	9	54	T	6E	n
26	&	41	A	55	U	6F	o
27	'	42	B	56	V	70	p
28	(43	C	57	W	71	q
29)	44	D	58	X	72	r
2A	*	45	E	59	Y	73	s
2B	+	46	F	5A	Z	74	t
2C	,	47	G	61	a	75	u
2D	-	48	H	62	b	76	v
2E	.	49	I	63	c	77	w
2F	/	4A	J	64	d	78	x
30	0	4B	K	68	e	79	y
31	1	4C	L	66	f	7A	z
32	2	4D	M	67	g		
33	3	4E	N	68	h		

■ S2-01/S2-06/S2-11/S2-16: Sequence Timers 1 to 4 Start Time

Sets the start times for timers 1 to 4.

If the Stop Time is set to a higher value than the Start Time, the Sequence Timers will be active starting from the set Start Time, run through midnight, and stop the following day at the set Stop Time.

Note: Setting the sequence timer start time to a higher value than the sequence timer stop time disables that sequence timer in drive software versions PRG: 8551 and earlier.

4.7 Basic U1000 iQpump Setup and Application Preset Parameters

No.	Name	Setting Range	Default
S2-01	Sequence Timer 1 Start Time	12:00AM to 11:59PM </>	12:00AM </>
S2-06	Sequence Timer 2 Start Time	12:00AM to 11:59PM </>	12:00AM </>
S2-11	Sequence Timer 3 Start Time	12:00AM to 11:59PM </>	12:00AM </>
S2-16	Sequence Timer 4 Start Time	12:00AM to 11:59PM </>	12:00AM </>

<1> Default is 00:00 and range is 00:00 to 24:00 when o4-20 is set to 1 (24-hour).

■ S2-04/S2-09/S2-14/S2-19: Sequence Timers 1/2/3/4 Selection

Sets the action that occurs when sequence timers 1 to 4 are active.

No.	Name	Setting Range	Default
S2-04	Sequence Timer 1 Selection	0 to 3	0
S2-09	Sequence Timer 2 Selection	0 to 3	0
S2-14	Sequence Timer 3 Selection	0 to 3	0
S2-19	Sequence Timer 4 Selection	0 to 3	0

Setting 0: Digital Output Only

Setting 1: Run

Setting 2: Run - PI Disable

Setting 3: Allow Alternation

When Sequence Selection is set to Allow Alternation and that timer is enabled (S2-03, S2-08, S2-13, S2-18 > 0), the drive will only allow 2 Motor alternation to occur during the time specified in the corresponding Sequence Timer. Alternation is disabled when the timer deactivates.

4.8 Test Run with No Load

◆ No-Load Operation Test Run

This section explains how to operate the drive with the motor decoupled from the load during a test run.

■ Before Starting the Motor

Check the following items before operation:

- Ensure the area around the motor is safe.
- Ensure external emergency stop circuitry is working properly and other safety precautions have been taken.





■ During Operation

Check the following items during operation:

- The motor should rotate smoothly (i.e., no abnormal noise or oscillation).
- The motor should accelerate and decelerate smoothly.

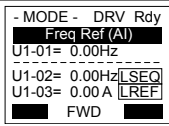
■ No-Load Operation Instructions

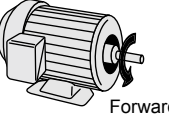
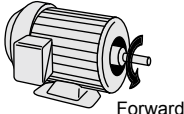
The following example illustrates a test run procedure using the HOA keypad.

Step			Display/Result
1.	Before starting the motor, set parameter d1-01, Frequency Reference, to 6 Hz. The Run command from AUTO mode must be OFF.	—	—
2.	Turn on the power to the drive. The initial display appears.	→	
3.	Press  to give the drive a Run command from HAND mode. The HAND light will turn on and the motor will rotate at 6 Hz.	→	
4.	Ensure the motor is rotating in the correct direction and that no faults or alarms occur.	→	
5.	If there is no error in step 3, press  to increase the frequency reference. Increase the frequency in increments of 10 Hz, verifying smooth operation at all speeds. For each frequency, check the drive output current using monitor U1-03. The current should be well below the motor rated current.	—	—
6.	The drive should operate normally. Press  to stop the motor. The HAND light is OFF and the motor coasts to stop.	→	

4.9 Test Run with Load Connected

◆ Test Run with the Load Connected

After performing a no-load test run, connect the motor and proceed to run the motor and load together.

■ Precautions for Connected Machinery

WARNING! *Sudden Movement Hazard. Clear all personnel from the drive, motor, and machine area before applying power. System may start unexpectedly upon application of power, causing death or serious injury.*

WARNING! *Sudden Movement Hazard. Always check the operation of any fast stop circuits after they are wired. Fast stop circuits are required to provide safe and quick shutdown of the drive. Prepare to initiate an emergency stop during the test run. Operating a drive with untested emergency circuits could result in death or serious injury.*

- The motor should come to a complete stop without problems.
- Connect the load and machinery to the motor.
- Fasten all installation screws properly and check that the motor and connected machinery are held in place.

■ Checklist Before Operation

- The motor should rotate in the proper direction.
- The motor should accelerate and decelerate smoothly.

■ Operating the Motor under Loaded Conditions

Test run the application similarly to the no-load test procedure when connecting the machinery to the motor.

- Monitor U1-03 for overcurrent during operation.
- If the application permits running the load in the reverse direction, change the motor direction and the frequency reference while watching for abnormal motor oscillation or vibration.
- Correct any problems that occur with hunting, oscillation, and other control-related issues.

Troubleshooting

This chapter provides descriptions of the drive faults, alarms, errors, related displays, and guidance for troubleshooting. This chapter can also serve as a reference guide for tuning the drive during a trial run.

5.1	MOTOR PERFORMANCE FINE-TUNING.....	202
5.2	DRIVE ALARMS, FAULTS, ERRORS, AND MESSAGES.....	204
5.3	FAULT DETECTION.....	205
5.4	ALARM DETECTION.....	222
5.5	OPERATOR PROGRAMMING ERRORS.....	236
5.6	AUTO-TUNING FAULT DETECTION.....	240
5.7	COPY FUNCTION RELATED DISPLAYS.....	243
5.8	HOA KEYPAD DISPLAY MESSAGES.....	245
5.9	AUTO-TUNING.....	247

5.1 Motor Performance Fine-Tuning

This section offers helpful information for counteracting oscillation, hunting, and other problems that occur while performing a trial run. Refer to the appropriate control method in this section.

Note: This section describes commonly edited parameters that may be set incorrectly. Consult Yaskawa for more information on detailed settings and for fine-tuning the drive.

◆ Fine-Tuning V/f Control

Table 5.1 Parameters for Fine-Tuning Performance in V/f Control

Problem	Parameter No.	Corrective Action	Default	Suggested Setting
Motor hunting and oscillation at speeds between 10 and 40 Hz	Hunting Prevention Gain (n1-02)	<ul style="list-style-type: none"> Reduce the setting if insufficient motor torque relative to the size of the load causes hunting. Increase the setting when motor hunting and oscillation occur with a light load. Reduce the setting if hunting occurs when using a motor with a relatively low inductance, such as a high-frequency motor or a motor with a larger frame size. 	1.00	0.10 to 2.00
<ul style="list-style-type: none"> Motor noise Motor hunting and oscillation at speeds up to 40 Hz 	Carrier Frequency Selection (C6-02)	<ul style="list-style-type: none"> Increase the carrier frequency If the motor noise is too loud. Lower the carrier frequency when motor hunting and oscillation occur at speeds up to 40 Hz. The default setting for the carrier frequency depends on the drive capacity (o2-04). 	1 (4 kHz) <1>	0 to 4, F <2>
<ul style="list-style-type: none"> Poor torque or speed response Motor hunting and oscillation 	Torque Compensation Primary Delay Time (C4-02)	<ul style="list-style-type: none"> Reduce the setting if motor torque and speed response are too slow. Increase the setting if motor hunting and oscillation occur. 	200 ms	100 to 1000 ms
<ul style="list-style-type: none"> Poor motor torque at speeds below 10 Hz Motor hunting and oscillation 	Torque Compensation Gain (C4-01)	<ul style="list-style-type: none"> Increase the setting if motor torque is insufficient at speeds below 10 Hz. Reduce the setting if motor hunting and oscillation with a relatively light load. 	1.00	0.50 to 1.50
<ul style="list-style-type: none"> Poor motor torque at low speeds Motor instability at motor start 	Mid Output Voltage A (E1-08) Minimum Output Voltage (E1-10)	<ul style="list-style-type: none"> Increase the setting if motor torque is insufficient at speeds below 10 Hz. Reduce the setting If motor instability occurs at motor start. 	Depends on o2-04, Drive Model Selection	Default setting ±5 V
Poor speed precision (V/f control)	Slip Compensation Gain (C3-01)	Set the motor-rated current (E2-01), motor-rated slip (E2-02), and motor no-load current (E2-03), then adjust the slip compensation gain (C3-01).	0.0 (no slip compensation)	0.5 to 1.5

<1> Default setting value is dependent on parameter o2-04, Drive Model Selection.

<2> Setting range is 1 to 4 and F for models 2□0028 to 2□0248, 4□0011 to 4□0414.
Setting range is 0 and F for models 4□0477 to 4□0930.

◆ Fine-Tuning Open Loop Vector Control

Table 5.2 Parameters for Fine-Tuning Performance in OLV

Problem	Parameter No.	Corrective Action	Default	Suggested Setting
<ul style="list-style-type: none"> Poor motor torque and speed response Motor hunting and oscillation at speeds between 10 and 40 Hz 	AFR Gain (n2-01)	<ul style="list-style-type: none"> Gradually reduce the setting in 0.05 increments if motor torque and speed response are too slow. Gradually increase the setting in 0.05 increments if motor hunting and oscillation occur. 	1.00	0.50 to 2.00
<ul style="list-style-type: none"> Poor motor torque and speed response Motor hunting and oscillation at speeds between 10 and 40 Hz 	AFR Time Constant 1 (n2-02)	<ul style="list-style-type: none"> Gradually reduce the setting in 10 ms increments and check the performance to improve motor torque speed response. Gradually increase the setting by 50 ms increments and check the performance if motor hunting and oscillation occur as a result of load inertia. 	50 ms	50 to 2000 ms

Problem	Parameter No.	Corrective Action	Default	Suggested Setting
<ul style="list-style-type: none"> Poor motor torque and speed response Motor hunting and oscillation 	Torque Compensation Primary Delay Time Constant 1 (C4-02)	<ul style="list-style-type: none"> Gradually reduce the setting in 2 ms increments and check the performance to improve motor torque speed response. Gradually increase the setting in 10 ms increments if motor hunting and oscillation occur. 	20 ms	20 to 100 ms
Poor speed response and stability	Slip Compensation Primary Delay Time Constant (C3-02)	<ul style="list-style-type: none"> Gradually reduce the setting in 10 ms increments if response is slow. Gradually increase the setting in 10 ms increments if speed is unstable. 	200 ms	100 to 500 ms
Poor speed precision	Slip Compensation Gain (C3-01)	<ul style="list-style-type: none"> Gradually increase the setting in 0.1 ms increments if speed is too slow. Gradually reduce the setting in 0.1 ms increments if speed is too fast. 	1.0	0.5 to 1.5
Poor speed precision during regenerative operation	Slip Compensation Selection During Regeneration (C3-04)	Enable slip compensation during regeneration by setting parameter C3-04 = 1.	0	1
<ul style="list-style-type: none"> Motor noise Motor hunting and oscillation occur at speeds below 10 Hz 	Carrier Frequency Selection (C6-02)	<ul style="list-style-type: none"> Increase the carrier frequency if there is too much motor noise. Reduce the carrier frequency if motor hunting and oscillation occur at low speeds. <p>Note: The default setting for the carrier frequency depends on the drive capacity (o2-04).</p>	1 (4 kHz) <1>	0 to 4, F <2>
<ul style="list-style-type: none"> Poor motor torque at low speeds Poor speed response Motor instability at start 	Mid Output Voltage A (E1-08) Minimum Output Voltage (E1-10)	<ul style="list-style-type: none"> Increase the setting if motor torque and speed response are too slow. Reduce the setting if the motor exhibits excessive instability at start-up. <p>Note: When working with a relatively light load, increasing this value too much can cause overtorque.</p>	Depends on o2-04, Drive Model Selection	Default setting ±2 V

<1> Default setting value is dependent on parameter o2-04, Drive Model Selection.

<2> Setting range is 1 to 4 and F for models 2□0028 to 2□0248, 4□0011 to 4□0414.

Setting range is 0 and F for models 4□0477 to 4□0930.

When using OLV, leave the torque compensation gain (C4-01) at its default setting of 1.00.

5.2 Drive Alarms, Faults, Errors, and Messages

◆ Types of Alarms, Faults, and Errors

Check the HOA keypad for information about possible faults if the drive or motor fails to operate. *Refer to Using the HOA Keypad on page 118.*

If problems occur that are not covered in this manual, contact the nearest Yaskawa representative with the following information:

- Drive model
- Software version
- Date of purchase
- Description of the problem
- List of modified parameters.

Table 5.3 contains descriptions of the various types of alarms, faults, and errors that may occur while operating the drive.

Table 5.3 Types of Alarms, Faults, and Errors

Type	Drive Response
Faults	<p>When the drive detects a fault:</p> <ul style="list-style-type: none"> • The HOA keypad displays text indicating the specific fault and the ALM indicator LED remains lit until the fault is reset. • The fault interrupts drive output and the motor coasts to a stop. • Some faults allow the user to select the stopping method when the fault occurs. • Fault output terminals MA-MC will close, and MB-MC will open. <p>The drive will remain inoperable until the fault is cleared. <i>Refer to Fault Reset Methods on page 246.</i></p>
Minor Faults and Alarms	<p>When the drive detects an alarm or a minor fault:</p> <ul style="list-style-type: none"> • The HOA keypad displays text indicating the specific alarm or minor fault, and the ALM indicator LED flashes. • The drive continues running the motor, although some alarms allow the user to select a stopping method when the alarm occurs. • A multi-function contact output set to be tripped by a minor fault (H2- □□ = 10) closes. If the output is set to be tripped by an alarm, the contact will not close. • The HOA keypad displays text indicating a specific alarm and the ALM indicator LED flashes. <p>Remove the cause of the problem to reset a minor fault or alarm.</p>
Operation Errors	<p>An operation error occurs when parameter settings conflict or do not match hardware settings (such as with an option card). When the drive detects an operation error:</p> <ul style="list-style-type: none"> • The HOA keypad displays text indicating the specific error. • Multi-function contact outputs do not operate. <p>The drive will not operate the motor until the error has been reset. Correct the settings that caused the operation error to clear the error.</p>
Tuning Errors	<p>Tuning errors occur while performing Auto-Tuning. When the drive detects a tuning error:</p> <ul style="list-style-type: none"> • The HOA keypad displays text indicating the specific error. • Multi-function contact outputs do not operate. • Motor coasts to stop. <p>Remove the cause of the error and repeat the Auto-Tuning process.</p>
Copy Function Errors	<p>Copy Function Errors occur when using the HOA keypad or the USB Copy Unit to copy, read, or verify parameter settings.</p> <ul style="list-style-type: none"> • The HOA keypad displays text indicating the specific error. • Multi-function contact outputs do not operate. <p>Pressing any key on the HOA keypad will clear the fault. Investigate the cause of the problem (such as model incompatibility) and try again.</p>
HOA Keypad Display Messages	<p>The drive will display messages on the HOA keypad to indicate temporary drive statuses during normal pump operation. Messages do not require any action from the user and will clear from the HOA keypad display automatically.</p>

5.3 Fault Detection

◆ Fault Displays, Causes, and Possible Solutions

Faults are detected for drive protection, and cause the drive to stop while triggering the fault output terminal MA-MB-MC. Remove the cause of the fault and manually clear the fault before attempting to run the drive again.

Table 5.4 Detailed Fault Displays, Causes, and Possible Solutions

HOA Keypad Display	Fault Name
ACCUM Accum Level	Accumulated Level Fault
Cause	Possible Solution
The accumulated level has exceeded the values set in P6-11 to P6-14. This is only effective when P6-15, Accumulated Behavior is set to 2 (fault with manual monitor reset) or 3 (fault with automatic monitor reset).	Set the Accumulated Level fault characteristics in P6-11 to P6-14 and P6-16. Drive response to this condition is controlled by P6-15, Accumulated Behavior. Auto-restart of this fault is controlled by P6-15, Accumulated Behavior and P6-05, Flow Accumulation Reset.
HOA Keypad Display	Fault Name
AJF Anti-Jam Fault	Anti-Jam Fault
Cause	Possible Solution
The drive was not able to clear debris from the impeller in fewer than the number of attempts set in P7-02. This is only effective when P7-01, Anti-jam Operation is set to 1 (enabled).	<ul style="list-style-type: none"> • Check for proper pump operation. Remove debris from the pump impeller. • Set the Anti-jam fault characteristics in P7-02 to P7-08. • Drive response to this condition is controlled by P7-01, Anti-jam Operation Selection.
HOA Keypad Display	Fault Name
Aov	Power Supply Overvoltage
Cause	Possible Solution
<ul style="list-style-type: none"> • The power supply voltage exceeded the range listed in drive input power specifications. • Regenerative operation was performed when the power supply capacity was too small. • The power supply circuit opened during regeneration. 	<ul style="list-style-type: none"> • Reduce the voltage to within the range in the power supply specifications. • Increase the capacity of the power supply.
HOA Keypad Display	Fault Name
AUv	Power Supply Undervoltage
Cause	Possible Solution
The capacity of the power supply is too small.	Increase the capacity of the power supply.
The distortion in the power supply is too large.	Lower the impedance of the input power supply wiring.
A phase loss occurred in the input power supply.	Check the input power supply for phase loss or an imbalance in the interphase voltages. Investigate and correct the cause and then reset the fault.
The built-in fuse is open.	An internal transistor was destroyed. The input wiring is grounded or short circuited. The output transistor has failed because the drive output has grounded or short circuited. Replace the board or the drive. For instructions on replacing the control board, contact Yaskawa or your nearest sales representative.

5.3 Fault Detection

HOA Keypad Display	Fault Name
AUXFB PI Aux Lvl Loss	Wire-break detection for PI Aux Feedback Level
Cause	Possible Solution
The analog input programmed for “PI Aux FB Level” (H3-□□ = 27) has dropped below 3 mA or risen above 21 mA for longer than 1 second.	Repair transducer or wiring.

HOA Keypad Display	Fault Name
bAT	Keypad Battery Voltage Low
Cause	Possible Solution
The keypad battery is low	Replace the keypad battery.

HOA Keypad Display	Fault Name
boL	Braking Transistor Overload Fault
	The braking transistor reached its overload level.
Cause	Possible Solution
The wrong braking resistor is installed	Select the correct braking resistor.

HOA Keypad Display	Fault Name
bUS	Option Communication Error
	<ul style="list-style-type: none"> The connection was lost after establishing initial communication. Only detected when the run command frequency reference is assigned to an option card.
Cause	Possible Solution
No signal was received from the PLC	<ul style="list-style-type: none"> Check for faulty wiring.
Faulty communications wiring or an existing short circuit	<ul style="list-style-type: none"> Correct the wiring. Check for disconnected cables and short circuits and repair as needed.
Communication data error occurred due to noise	<ul style="list-style-type: none"> Check the various options available to minimize the effects of noise. Counteract noise in the control circuit, main circuit, and ground wiring. Ensure that other equipment such as switches or relays do not cause noise. Use surge absorbers if necessary. Use only recommended cables or other shielded line. Ground the shield on the controller side or the drive input power side. Separate all communication wiring from drive power lines. Install an EMC noise filter to the drive power supply input.
The option card is damaged	Replace the option card if there are no problems with the wiring and the error continues to occur.
The option card is not properly connected to the drive	<ul style="list-style-type: none"> The connector pins on the option card do not line up properly with the connector pins on the drive. Reinstall the option card.

HOA Keypad Display	Fault Name
CE	MEMOBUS/Modbus Communication Error
	Control data was not received for the CE detection time set to H5-09.
Cause	Possible Solution
Faulty communications wiring or an existing short circuit	<ul style="list-style-type: none"> Check for faulty wiring. Correct the wiring. Check for disconnected cables and short circuits and repair as needed.
Communication data error occurred due to noise	<ul style="list-style-type: none"> Check the various options available to minimize the effects of noise. Counteract noise in the control circuit, main circuit, and ground wiring. Use only recommended cables or other shielded line. Ground the shield on the controller side or the drive input power side. Ensure that other equipment such as switches or relays do not cause noise. Use surge suppressors if required. Separate all communication wiring from drive power lines. Install an EMC noise filter to the drive power supply input.

HOA Keypad Display	Fault Name
CF	Control Fault
	The torque limit was reached continuously for three seconds after the Stop command was input and deceleration was not possible in OLV Control.
Cause	Possible Solution
Motor parameters are set improperly	Check the motor parameter settings and repeat Auto-Tuning.
Torque limit is too low	Set the torque limit to the most appropriate setting (L7-01 through L7-04).
Load inertia is too big	<ul style="list-style-type: none"> Adjust the deceleration time (C1-02, C1-04, C1-06). Set the frequency to the minimum value and interrupt the Run command when the drive finishes decelerating.

HOA Keypad Display	Fault Name
CoF	Current Offset Fault
	Drive starts operation while the current-detection circuit failure, or the induced voltage remains in the motor (coasting and after rapid deceleration).
Cause	Possible Solution
The drive performed a current offset adjustment while the motor was rotating	<ul style="list-style-type: none"> The set value exceeds the allowable setting range while the drive automatically adjusts the current offset. Set b3-01 to 1 to enable Speed Search at Start. Perform Speed Search 1 or 2 (H1-□□ = 61 or 62) via one of the external terminals.
Hardware problem	If the problem continues, replace the control board or the entire drive. Contact Yaskawa or a Yaskawa representative for instructions on replacing the control board.

HOA Keypad Display	Fault Name
CPF00 to CPF03, CPF07, CPF08, CPF11 to CPF14, CPF16 to CPF24, CPF26 to CPF35, CPF40 to CPF45	Control Circuit Error
Cause	Possible Solution
Hardware is damaged.	<ul style="list-style-type: none"> Cycle power to the drive. If the problem continues, replace either the control board or the entire drive. For instructions on replacing the control board, contact Yaskawa or your nearest sales representative.
Connector on the keypad is damaged.	Replace the keypad.

HOA Keypad Display	Fault Name
CPF06	EEPROM Memory Data Error
	Error in the data saved to EEPROM
Cause	Possible Solution
There is an error in EEPROM control circuit	<ul style="list-style-type: none"> Turn off the power and check the connection between the control board and the drive. If the problem continues, replace the control board or the entire drive. Contact Yaskawa or a Yaskawa representative for instructions on replacing the control board.
The power supply was switched off while parameters were being saved to the drive	Reinitialize the drive (A1-03 = 2220, 3330).

HOA Keypad Display	Fault Name
CPF25	Terminal Board Not Connected
Cause	Possible Solution
Terminal board is not connected correctly	Reconnect the terminal board to the connector on the drive, then cycle the power to the drive.

HOA Keypad Display	Fault Name
DIFF Differential Det	Differential Feedback Detected
	Possible Solution
The difference between the PID Feedback and the Differential Feedback (H3-□□ = 28) exceeded the P4-18 level for the time set in P4-19.	<ul style="list-style-type: none"> Replace the feedback transducer or transducers. Verify parameter settings P4-18 to P4-20.

5.3 Fault Detection

HOA Keypad Display	Fault Name
doH	Damping Resistor Overheat The temperature of the built-in damping resistor exceeded the set value.
Cause	Possible Solution
<ul style="list-style-type: none"> The capacity of the power supply is too small. The distortion in the power supply is too large. 	<ul style="list-style-type: none"> Increase the capacity of the power supply. Lower the impedance of the input power supply wiring.
A phase loss occurred in the input power supply.	Check the input power supply for phase loss or an imbalance in the interphase voltages.

HOA Keypad Display	Fault Name
E5	SI-T3 Watchdog Timer Error The watchdog timed out.
Cause	Possible Solution
Data has not been received from the PLC	Execute DISCONNECT or ALM_CLR, then issue a CONNECT command or SYNC_SET command and proceed to phase 3. Refer to the SI-T3 Option Technical Manual for more details on troubleshooting.

HOA Keypad Display	Fault Name
EF0	Option Card External Fault An external fault condition is present.
Cause	Possible Solution
An external fault was received from the PLC and F6-03 ≠ 3.	<ul style="list-style-type: none"> Remove the cause of the external fault. Remove the external fault input from the PLC.
Problem with the PLC program	Check the PLC program and correct problems.

HOA Keypad Display	Fault Name
EF1	Pump Fault (input terminal S1) External fault at multi-function input terminal S1.
EF2	Pump Fault (input terminal S2) External fault at multi-function input terminal S2.
EF3	Pump Fault (input terminal S3) External fault at multi-function input terminal S3.
EF4	Pump Fault (input terminal S4) External fault at multi-function input terminal S4.
EF5	Pump Fault (input terminal S5) External fault at multi-function input terminal S5.
EF6	Pump Fault (input terminal S6) External fault at multi-function input terminal S6.
EF7	Pump Fault (input terminal S7) External fault at multi-function input terminal S7.
EF8	Pump Fault (input terminal S8) External fault at multi-function input terminal S8.
Cause	Possible Solution
An external device tripped an alarm function	Remove the cause of the external fault and reset the fault.
Wiring is incorrect	<ul style="list-style-type: none"> Properly connect the signal lines to the terminals assigned for pump fault detection (H1-□□ = 20 to 2F). Reconnect the signal line.
Multi-function contact input setting is incorrect	<ul style="list-style-type: none"> Check for unused terminals set for H1-□□ = 20 to 2F (Pump Fault). Change the terminal settings.

HOA Keypad Display	Fault Name
Err	EEPROM Write Error Data cannot be written to the EEPROM

HOA Keypad Display	Fault Name
Cause	Possible Solution
Noise has corrupted data while writing to the EEPROM	<ul style="list-style-type: none"> Press “ENTER” on the keypad. Correct the parameter setting. Cycle power to the drive. If the problem continues, replace the control board or the entire drive. Contact Yaskawa or a Yaskawa representative for instructions on replacing the control board.
Hardware problem	If the problem continues, replace the control board or the entire drive. Contact Yaskawa or a Yaskawa representative for instructions on replacing the control board.

HOA Keypad Display	Fault Name
FAn	Internal Fan Fault
	Fan or magnetic contactor failure
Cause	Possible Solution
Internal cooling fan has malfunctioned	<ul style="list-style-type: none"> Cycle power to the drive. Check for fan operation. Verify the cumulative operation time of the fan with monitor U4-03, and verify the cumulative operation time of the fan maintenance timer with U4-04. If the cooling fan has exceeded its expected performance life or is damaged in any other way, follow the replacement instructions in the <i>Peripheral Devices & Options</i> chapter.
Fault detected in the internal cooling fan or magnetic contactor to the power supply.	<ul style="list-style-type: none"> Cycle power to the drive. If the fault continues to occur, replace the power board/gate drive board or the entire drive. Contact Yaskawa or a Yaskawa representative for instructions on replacing the power board/gate drive board.

HOA Keypad Display	Fault Name
FbL	PID Feedback Loss
	PID feedback loss detection is programmed to trigger a fault (b5-12 = 2) and the PID feedback level is below the detection level set to b5-13 for longer than the time set to b5-14.
Cause	Possible Solution
Parameters are set inappropriately	Check b5-13 and b5-14 settings.
Incorrect PID feedback wiring	Correct the wiring.
There is a problem with the feedback sensor	<ul style="list-style-type: none"> Check the sensor on the control side. Replace the sensor if damaged.

HOA Keypad Display	Fault Name
FDBKL Wire Break	PID Feedback Loss
	The analog input programmed for PID feedback has risen above 21 mA or fallen below 3 mA.
Cause	Possible Solution
The analog input programmed for PID feedback loss has risen above 21 mA or fallen below 3 mA. This is effective only when b5-12 Feedback Loss 4 to 20 mA Detection Selection is set to 2 (fault).	<ul style="list-style-type: none"> Confirm that the PID feedback source is installed and working properly. Drive response to this condition is controlled by b5-12, Feedback Loss 4 to 20 mA Detection Selection and b5-13, Feedback Loss Go To Frequency. Auto-restart of this fault is controlled by L5-42, Feedback Loss Fault Retry Selection.

HOA Keypad Display	Fault Name
Fdv	Power Supply Frequency Fault
	The input power supply frequency exceeded the allowable frequency fluctuation.
Cause	Possible Solution
A momentary power loss occurred.	Reset the fault.
An input power supply wiring terminal is loose.	Check for loose terminals.
The fluctuation in the voltage of the input power supply is too large.	Increase the power supply frequency fault detection width (L2-27).
The built-in fuse is open.	Replace either the control board or the entire drive. For instructions on replacing the control board, contact Yaskawa or your nearest sales representative.

5.3 Fault Detection

HOA Keypad Display	Fault Name
GF	Ground Fault
	<ul style="list-style-type: none"> A current short to ground exceeded 50% of rated current on the output side of the drive. Setting L8-09 to 1 enables ground fault detection.
Cause	Possible Solution
Motor insulation is damaged	<ul style="list-style-type: none"> Check the insulation resistance of the motor. Replace the motor.
A damaged motor cable is creating a short circuit	<ul style="list-style-type: none"> Check the motor cable. Remove the short circuit and reapply power to the drive
	<ul style="list-style-type: none"> Check the resistance between the cable and the ground terminal ⊕. Replace the cable.
Excessive leakage current at the drive output	<ul style="list-style-type: none"> Reduce the carrier frequency. Reduce the amount of stray capacitance.
The drive started to run during a current offset fault or while coasting to a stop	<ul style="list-style-type: none"> Set b3-01 to 1 to enable Speed Search at Start. Perform Speed Search 1 or 2 (H1-□□ = 61 or 62) via one of the external terminals.
Hardware problem	If the problem continues, replace the control board or the entire drive. Contact Yaskawa or a Yaskawa representative for instructions on replacing the control board.

HOA Keypad Display	Fault Name
HFB	High Feedback
	The feedback signal is too high.
Cause	Possible Solution
The feedback signal has risen above the level set in P1-11, High Feedback Level, for the time set in P1-12, High Feedback Level Fault Delay Time. This is effective only when P1-13, High Feedback Selection, is set to 0 (Fault and digital out).	<ul style="list-style-type: none"> Set the High Feedback fault characteristics in P1-11 and P1-12. Drive response to this condition is controlled by P1-13, High Feedback Selection. Auto-restart of this fault is controlled by L5-41, High Feedback Fault Retry Selection.

HOA Keypad Display	Fault Name
HIAUX High PI Aux Lvl	High PI Auxiliary Feedback Level
Cause	Possible Solution
PI Aux Feedback has risen above the Q6-12 level for longer than the time set in Q6-13 and the drive is running in AUTO, and output frequency is greater than zero.	<ul style="list-style-type: none"> Lower the PI Aux Feedback level Adjust parameters Q6-12 and Q6-13.

HOA Keypad Display	Fault Name
HIFLO High Flow	High Flow
	The meter has detected a high flow condition.
Cause	Possible Solution
The flow is too high	Reduce the flow
The measured water flow has risen above the P6-17 level for the time set in P6-18. This is only effective when P6-19, High Flow Select is set to 2 (fault).	<ul style="list-style-type: none"> Set the High Flow fault characteristics in P6-17 and P6-18. Drive response to this condition is controlled by P6-19, High Flow Select. Auto-restart of this fault is controlled by P6-19, High Flow Select.

HOA Keypad Display	Fault Name
HISUC High Suction	High Section Pressure
Cause	Possible Solution
The suction pressure has fallen below the level set in Q5-12 for longer than the time set in Q5-13. This is only effective when Q5-14, High Suction Pressure Behavior Select, is set to 2 (fault).	<ul style="list-style-type: none"> Reduce the system pressure. Set the High Suction Pressure fault characteristics in Q5-12, Q5-13, and Q5-18. Drive response to this condition is controlled by Q5-14, High Suction Pressure Behavior Select. Auto-restart of this fault is controlled by Q5-14, High Suction Pressure Behavior Select and Q5-15, Suction Pressure Auto-restart Time.

HOA Keypad Display	Fault Name
HWL	High Water Level
	The “High Water Level” digital input is active (H1-0□ = 90).
Cause	Possible Solution
The Low Water Level switch is activated or P1-31, High Water Digital Input Configuration, is programmed incorrectly.	Lower the water level and/or adjust the High Water Level switch.

HOA Keypad Display	Fault Name
LF	Output Phase Loss
	<ul style="list-style-type: none"> Phase loss on the output side of the drive. Setting L8-07 to 1 or 2 enables Phase Loss Detection.
Cause	Possible Solution
The output cable is disconnected	<ul style="list-style-type: none"> Check for wiring errors and properly connect the output cable. Correct the wiring.
The motor winding is damaged	<ul style="list-style-type: none"> Check the resistance between motor lines. Replace the motor if the winding is damaged.
The output terminal is loose	<ul style="list-style-type: none"> Apply the tightening torque specified in this manual to fasten the terminals. <i>Refer to Main Circuit Wire Gauges and Tightening Torque on page 86</i> for details.
The rated current of the motor being used is less than 5% of the drive rated current	Check the drive and motor capacities.
An output transistor is damaged	If the problem continues, replace the control board or the entire drive. Contact Yaskawa or a Yaskawa representative for instructions on replacing the control board.
A single-phase motor is being used	The drive cannot operate a single phase motor.

HOA Keypad Display	Fault Name
LFB	Low Feedback
	The feedback signal is too low.
Cause	Possible Solution
The feedback signal has dropped below the level set in P1-08, Low Feedback Level, for the time set in P1-09, Low Feedback Level Fault Delay Time. This is effective only when P1-10, Low Feedback Selection, is set to 0 (Fault and digital out).	<ul style="list-style-type: none"> Set the Low Feedback fault characteristics in P1-08 and P1-09. Drive response to this condition is controlled by P1-10, Low Feedback Selection. Auto-restart of this fault is controlled by L5-40, Low Feedback Fault Retry Selection.

HOA Keypad Display	Fault Name
LF2	Output Current Imbalance
	One or more of the phases in the output current are lost.
Cause	Possible Solution
Phase loss has occurred on the output side of the drive	<ul style="list-style-type: none"> Check for faulty wiring or poor connections on the output side of the drive. Correct the wiring.
Terminal wires are loose on the output side of the drive	Apply the tightening torque specified in this manual to fasten the terminals. <i>Refer to Main Circuit Wire Gauges and Tightening Torque on page 86</i> for details.
The output circuit is damaged	If the problem continues, replace the control board or the entire drive. Contact Yaskawa or a Yaskawa representative for instructions on replacing the control board.
Motor impedance or motor phases are uneven	<ul style="list-style-type: none"> Measure the line-to-line resistance for each motor phase. Ensure all values match. Replace the motor.

HOA Keypad Display	Fault Name
LOAUX Low PI Aux Lvl	Low PI Auxiliary Feedback Level
	Possible Solution
PI Aux Feedback has fallen below the Q6-09 level for longer than the time set in Q6-10 and the drive is running in HAND or AUTO.	<ul style="list-style-type: none"> Raise the PI Aux Feedback level Adjust parameters Q6-09 and Q6-10.

5.3 Fault Detection

HOA Keypad Display	Fault Name
LOP	Loss of Prime The pump has lost its prime.
Cause	Possible Solution
The pump load, measured based on the P1-18 setting (output current, kilowatts, or power), has dropped below the level set in P1-19, Prime Loss Level, for the time set in P1-20, Loss of Prime Time, and the output frequency has risen above P1-21, Prime Loss Frequency. This is effective only when P1-22 Loss of Prime Selection is set to 0 (fault).	<ul style="list-style-type: none"> • Check for a dry well, air in the system, or no water in the system. Restart the pump using the preferred priming method suggested by the pump manufacturer. • Set the Loss of Prime fault characteristics in P1-18, P1-19, P1-20, and P1-21. • Drive response to this condition is controlled by P1-21, Loss of Prime Selection. • Auto-restart of this fault is controlled by L5-51, Loss of Prime Fault Retry Selection and P1-23, Loss of Prime Maximum Restart Time after Fault

HOA Keypad Display	Fault Name
LOSUC Low Suction	Low Section Pressure
Cause	Possible Solution
The suction pressure has fallen below the level set in Q5-09 for longer than the time set in Q5-10. This is only effective when Q5-11, Low Suction Pressure Behavior Select is set to 2 (fault).	<ul style="list-style-type: none"> • Increase the system pressure. • Set the Low Suction fault characteristics in Q5-09, Q5-10, and Q5-18. • Drive response to this condition is controlled by Q5-11, Low Suction Pressure Behavior Select. • Auto-restart of this fault is controlled by Q5-11, Low Suction Pressure Behavior Select and Q5-15, Suction Pressure Auto-restart Time.

HOA Keypad Display	Fault Name
LOWFL Low Flow	Low Flow
Cause	Possible Solution
Insufficient flow	Increase flow
After waiting the P6-08 delay time at start, the measured water flow has fallen below the P6-06 level for the time set in P6-07. This is only effective when P1-09, Low Flow Select is set to 2 (fault).	<ul style="list-style-type: none"> • Set the Low Flow fault characteristics in P6-06, P6-07, and P6-08. • Drive response to this condition is controlled by P6-09, Low Flow Select. • Auto-restart of this fault is controlled by P6-09, Low Flow Select and P6-10, Low Flow Auto-restart Time.

HOA Keypad Display	Fault Name
LOWWL Low Water Level	Low Water Level
Cause	Possible Solution
The water level has fallen below the level set in Q4-09 for the longer than the time set in Q4-10. This is only effective when Q4-11, Low Level Behavior is set to 2 (fault).	<ul style="list-style-type: none"> • Raise the water level. • Set the Low Water Level fault characteristics in Q4-09 and Q4-10. • Drive response to this condition is controlled by Q4-11, Low Level Behavior. • Auto-restart of this fault is controlled by Q4-11, Low Level Behavior and Q4-12 Water Level Control Auto-restart Time.

HOA Keypad Display	Fault Name
LWL	Low Water Level The “Low Water Level” digital input is active (H1-0□ = 8F).
Cause	Possible Solution
The Low Water Level switch is activated, defective, or P1-30, Low Water Digital Input Configuration, is programmed incorrectly.	Raise the water level and/or adjust the Low Water Level switch.

HOA Keypad Display	Fault Name
NMS	Not Maintaining Setpoint The setpoint cannot be maintained and P1-17 is set to 0.
Cause	Possible Solution

HOA Keypad Display	Fault Name
When the feedback deviates from the setpoint at a level greater than P1-15, for a time set in P1-16. This is effective only when P1-17 is set to 0 (fault).	<ul style="list-style-type: none"> • Check for a blocked impeller, over cycling, or broken pipe. • Set the Not Maintaining Setpoint fault characteristics in P1-16 and P1-17. • Drive response to this condition is controlled by P1-17, Not Maintaining Setpoint Selection. • Auto-restart of this fault is controlled by L5-50, Setpoint Not Met Retry.

HOA Keypad Display	Fault Name
nSE	Node Setup Error
	A terminal assigned to the node setup function closed during run.
Cause	Possible Solution
The node setup terminal closed during run.	Stop the drive when using the node setup function.
A Run command was issued while the node setup function was active.	

HOA Keypad Display	Fault Name
oC	Overcurrent
	Drive sensors detected an output current greater than the specified overcurrent level.
Cause	Possible Solution
The motor has been damaged due to overheating or the motor insulation is damaged	<ul style="list-style-type: none"> • Check the insulation resistance. • Replace the motor.
One of the motor cables has shorted out or there is a grounding problem	<ul style="list-style-type: none"> • Check the motor cables. • Remove the short circuit and reapply power to the drive.
	<ul style="list-style-type: none"> • Check the resistance between the motor cables and the ground terminal ⊕. • Replace damaged cables.
The load is too heavy	<ul style="list-style-type: none"> • Measure the current flowing into the motor. • Replace the drive with a larger capacity drive if the current value exceeds the rated current. • Determine if there is sudden fluctuation in the current level. • Reduce the load to avoid sudden changes in the current level or switch to a larger drive.
The acceleration or deceleration times are too short	<p>Calculate the torque needed during acceleration relative to the load inertia and the specified acceleration time. If it is not possible to set the proper amount of torque, make the following changes:</p> <ul style="list-style-type: none"> • Increase the acceleration time (C1-01, C1-03). • Increase the S-curve characteristics (C2-01 through C2-04). • Increase the capacity of the drive.
The drive is attempting to operate a specialized motor or a motor larger than the maximum size allowed	<ul style="list-style-type: none"> • Check the motor capacity. • Ensure that the rated capacity of the drive is greater than or equal to the capacity rating found on the motor nameplate.
Magnetic contactor (MC) on the output side of the drive has turned on or off	Set up the operation sequence so the MC does not trip while the drive is outputting current.
V/f setting is not operating as expected	<ul style="list-style-type: none"> • Check the ratios between the voltage and frequency. • Set parameters E1-04 through E1-10 appropriately. • Lower the voltage if it is too high relative to the frequency.
Excessive torque compensation	<ul style="list-style-type: none"> • Check the amount of torque compensation. • Reduce the torque compensation gain (C4-01) until there is no speed loss and less current.
Drive fails to operate properly due to noise interference	<ul style="list-style-type: none"> • Review the possible solutions provided for handling noise interference. • Review the section on handling noise interference and check the control circuit lines, main circuit lines, and ground wiring.
Overexcitation gain is set too high	<ul style="list-style-type: none"> • Check if the fault occurs simultaneously with overexcitation function operation. • Consider motor flux saturation and reduce the value of n3-13 (Overexcitation Deceleration Gain).
Run command was applied while motor was coasting	<ul style="list-style-type: none"> • Set b3-01 to 1 to enable Speed Search at Start. • Program the Speed Search command input through one of the multi-function contact input terminals (H1-□□ = 61 or 62).
The rated output current of the drive is too small	Use a larger drive.

5.3 Fault Detection

HOA Keypad Display	Fault Name
oFA00	Option Card Connection Error at Option Port CN5-A
	Option compatibility error
Cause	Possible Solution
The option card installed into port CN5-A is incompatible with the drive	Check if the drive supports the option card to be installed. Contact Yaskawa for assistance.

HOA Keypad Display	Fault Name
oFA01	Option Card Fault at Option Port CN5-A
	Option not properly connected
Cause	Possible Solution
The option card connection to port CN5-A is faulty	<ul style="list-style-type: none"> Turn off the power and reconnect the option card. Check if the option card is properly plugged into the option port. Make sure the card is fixed properly. If the option is not a communication option card, try to use the card in a different option port. If the option card works properly in a different option port, CN5-A is damaged, and the drive requires replacement. If the error persists (oFb01 or oFC01 occur), replace the option card.

HOA Keypad Display	Fault Name
oFA03 to oFA06	Option Card Error Occurred at Option Port CN5-A
oFA12 to oFA17	Option Card Connection Error (CN5-A)
oFA30 to oFA43	Communication Option Card Connection Error (CN5-A)
Cause	Possible Solution
Option card or hardware is damaged	<ul style="list-style-type: none"> Cycle power to the drive. If the problem continues, replace the control board or the entire drive. Contact Yaskawa or a Yaskawa representative for instructions on replacing the control board.

HOA Keypad Display	Fault Name
oFb00	Option Card Fault at Option Port CN5-B
	Option compatibility error
Cause	Possible Solution
The option card installed into port CN5-B is incompatible with the drive	Make sure the drive supports the option card to be installed. Contact Yaskawa for assistance.
A communication option card has been installed in option port CN5-B	Communication option cards are only supported by option port CN5-A. It is not possible to install more than one communication option.

HOA Keypad Display	Fault Name
oFb01	Option Card Fault at Option Port CN5-B
	Option not properly connected
Cause	Possible Solution
The option card connection to port CN5-B is faulty	<ul style="list-style-type: none"> Turn off the power and reconnect the option card. Check if the option card is properly plugged into the option port. Make sure the card is fixed properly. Try to use the card in a different option port. If the option card works properly in a different option port, CN5-B is damaged, and the drive requires replacement. If the error persists (oFA01 or oFC01 occur), replace the option card.

HOA Keypad Display	Fault Name
oFb02	Option Card Fault at Option Port CN5-B
	Same type of option card is currently connected
Cause	Possible Solution
An option card of the same type is already installed in option port CN5-A	Only one of each option card type can only be installed simultaneously. Make sure only one type of option card is connected.
An input option card is already installed in option port CN5-A	Install a communication option. More than one of the same type of card cannot be installed simultaneously.

HOA Keypad Display	Fault Name
oFb03 to oFb11	Option card error occurred at Option Port CN5-B
oFb12 to oFb17	

HOA Keypad Display	Fault Name
Cause	Possible Solution
Option card or hardware is damaged	<ul style="list-style-type: none"> • Cycle power to the drive. • If the problem continues, replace the control board or the entire drive. Contact Yaskawa or a Yaskawa representative for instructions on replacing the control board.

HOA Keypad Display	Fault Name
oFC00	Option Card Connection Error at Option Port CN5-C
	Option compatibility error
Cause	Possible Solution
The option card installed into port CN5-C is incompatible with the drive	Confirm that the drive supports the option card to be installed. Contact Yaskawa for assistance.
A communication option card has been installed in option port CN5-C	Communication option cards are only supported by option port CN5-A. It is not possible to install more than one communication option.

HOA Keypad Display	Fault Name
oFC01	Option Card Fault at Option Port CN5-C
	Option not properly connected
Cause	Possible Solution
The option card connection to port CN5-C is faulty.	<ul style="list-style-type: none"> • Turn the power off and reconnect the option card. • Check if the option card is properly plugged into the option port. Make sure the card is fixed properly. • Try to use the card in a different option port. If the option card works properly in a different option port, CN5-C is damaged, and the drive requires replacement. If the error persists (oFA01 or oFb01 occur), replace the option card.

HOA Keypad Display	Fault Name
oFC02	Option Card Fault at Option Port CN5-C
	Same type of option card is currently connected
Cause	Possible Solution
An option card of the same type is already installed in option port CN5-A or CN5-B.	Only one of each option card type can only be installed simultaneously. Make sure only one type of option card is connected.
An input option card is already installed in option port CN5-A or CN5-B.	Install a communication option, a digital input option, or an analog input option. More than one of the same type of card cannot be installed simultaneously.

HOA Keypad Display	Fault Name
oFC03 to oFC11	Option Card Error Occurred at Option Port CN5-C
oFC12 to oFC17	
Cause	Possible Solution
Option card or hardware is damaged	<ul style="list-style-type: none"> • Cycle power to the drive. • If the problem continues, replace the control board or the entire drive. Contact Yaskawa or a Yaskawa representative for instructions on replacing the control board.

HOA Keypad Display	Fault Name
oFC50 to oFC55	Option Card Error Occurred at Option Port CN5-C
Cause	Possible Solution
Option card or hardware is damaged	Refer to the appropriate option manual for details.

HOA Keypad Display	Fault Name
oH	Heatsink Overheat
	The heatsink temperature exceeded the overheat pre-alarm level set to L8-02.
Cause	Possible Solution
Surrounding temperature is too high	<ul style="list-style-type: none"> • Check the temperature surrounding the drive. Verify temperature is within drive specifications. • Improve the air circulation within the enclosure panel. • Install a fan or air conditioner to cool the surrounding area. • Remove anything near the drive that might be producing excessive heat.
Load is too heavy	<ul style="list-style-type: none"> • Measure the output current. • Decrease the load. • Lower the carrier frequency (C6-02).

5.3 Fault Detection

HOA Keypad Display	Fault Name
Internal cooling fan is stopped	<ul style="list-style-type: none"> • Replace the cooling fan. . • After replacing the cooling fan, set parameter o4-03 to 0 to reset the cooling fan maintenance.

HOA Keypad Display	Fault Name
oH1	Overheat 1 (Heatsink Overheat) The heatsink temperature exceeded the drive overheat level.
Cause	Possible Solution
Surrounding temperature is too high	<ul style="list-style-type: none"> • Check the temperature surrounding the drive. • Improve the air circulation within the enclosure panel. • Install a fan or air conditioner to cool the surrounding area. • Remove anything near the drive that might be producing excessive heat.
Load is too heavy	<ul style="list-style-type: none"> • Measure the output current. • Lower the carrier frequency (C6-02). • Reduce the load.

HOA Keypad Display	Fault Name
oH3	Motor Overheat Alarm (PTC Input) <ul style="list-style-type: none"> • The motor overheat signal to analog input terminal A1, A2, or A3 exceeded the fault detection level. • Detection requires setting multi-function analog inputs H3-02, H3-10, or H3-06 to E.
Cause	Possible Solution
Motor has overheated	<ul style="list-style-type: none"> • Check the size of the load, the accel/decel times, and the cycle times. • Decrease the load. • Increase the acceleration and deceleration times (C1-01 through C1-04).
	<ul style="list-style-type: none"> • Adjust the preset V/f pattern (E1-04 through E1-10) by reducing E1-08 and E1-10. • Do not set E1-08 and E1-10 too low. This reduces load tolerance at low speeds. • Check the motor rated current. • Enter the motor rated current to parameter E2-01 as indicated on the motor nameplate. • Ensure the motor cooling system is operating normally. • Repair or replace the motor cooling system.

HOA Keypad Display	Fault Name
oH4	Motor Overheat Fault (PTC Input) <ul style="list-style-type: none"> • The motor overheat signal to analog input terminal A1, A2, or A3 exceeded the fault detection level. • Detection requires setting multi-function analog inputs H3-02, H3-10, or H3-06 to E.
Cause	Possible Solution
Motor has overheated	<ul style="list-style-type: none"> • Check the size of the load, the accel/decel times, and the cycle times. • Decrease the load. • Increase the acceleration and deceleration times (C1-01 through C1-04).
	<ul style="list-style-type: none"> • Adjust the preset V/f pattern (E1-04 through E1-10) by reducing E1-08 and E1-10. • Do not set E1-08 and E1-10 too low. This reduces load tolerance at low speeds. • Check the motor rated current. • Enter the motor rated current to parameter E2-01 as indicated on the motor nameplate. • Ensure the motor cooling system is operating normally. • Repair or replace the motor cooling system.

HOA Keypad Display	Fault Name
oL1	Motor Overload The electronic motor overload protection tripped
Cause	Possible Solution
Load is too heavy	Reduce the load.
Cycle times are too short during acceleration and deceleration	Increase the acceleration and deceleration times (C1-01 through C1-04).

HOA Keypad Display	Fault Name
A general-purpose motor is driven below the rated speed with a high load	<ul style="list-style-type: none"> Reduce the load. Increase the speed. If the motor is supposed to operate at low speeds, either increase the motor capacity or use a motor specifically designed to operate in the desired speed range.
The output voltage is too high	<ul style="list-style-type: none"> Adjust the user-set V/f pattern (E1-04 through E1-10) by reducing E1-08 and E1-10. Do not set E1-08 and E1-10 too low. This reduces load tolerance at low speeds.
The wrong motor rated current is set to E2-01	<ul style="list-style-type: none"> Check the motor-rated current. Enter the motor rated current to parameter E2-01 as indicated on the motor nameplate.
The base frequency is set incorrectly	<ul style="list-style-type: none"> Check the rated frequency indicated on the motor nameplate. Enter the rated frequency to E1-06 (Base Frequency).
The electrical thermal protection characteristics and motor overload characteristics do not match	<ul style="list-style-type: none"> Check the motor characteristics. Correct the type of motor protection that has been selected (L1-01). Install an external thermal relay.
The electrical thermal relay is operating at the wrong level	<ul style="list-style-type: none"> Check the current rating listed on the motor nameplate. Check the value set for the motor rated current (E2-01).
Motor overheated by overexcitation operation	<ul style="list-style-type: none"> Overexcitation increases the motor loss and the motor temperature. Excessive duration of overexcitation may cause motor damage. Prevent excessive overexcitation operation or apply proper cooling to the motor. Reduce the excitation deceleration gain (n3-13). Set L3-04 (Stall Prevention during Deceleration) to a value other than 4.
Parameters related to Speed Search are set incorrectly	<ul style="list-style-type: none"> Check values set to Speed Search related parameters. Adjust the Speed Search current and Speed Search deceleration times (b3-02 and b3-03 respectively). After Auto-Tuning, set b3-24 to 1 to enable Speed Estimation Speed Search.
Output current fluctuation due to power supply loss	Check the power supply for phase loss.

HOA Keypad Display	Fault Name
oL2	Drive Overload
	The thermal sensor of the drive triggered overload protection.
Cause	Possible Solution
Load is too heavy	Reduce the load.
Acceleration or deceleration time is too short	Increase the settings for the acceleration and deceleration times (C1-01 through C1-04).
The output voltage is too high	<ul style="list-style-type: none"> Adjust the preset V/f pattern (E1-04 through E1-10) by reducing E1-08 and E1-10. Do not lower E1-08 and E1-10 excessively. This reduces load tolerance at low speeds.
Drive capacity is too small	Replace the drive with a larger model.
Overload occurred when operating at low speeds	<ul style="list-style-type: none"> Reduce the load when operating at low speeds. Replace the drive with a model that is one frame size larger. Lower the carrier frequency (C6-02).
Excessive torque compensation	Reduce the torque compensation gain in parameter C4-01 until there is less current but no speed loss.
Parameters related to Speed Search are set incorrectly	<ul style="list-style-type: none"> Check the settings for all Speed Search related parameters. Adjust the current used during Speed Search (b3-03) and the Speed Search deceleration time (b3-02). After Auto-Tuning, set b3-24 to 1 to enable Speed Estimation Speed Search.
Output current fluctuation due to input phase loss	Check the power supply for phase loss.

HOA Keypad Display	Fault Name
oL3	Overtorque Detection 1
	The current has exceeded the value set for torque detection (L6-02) for longer than the allowable time (L6-03).
Cause	Possible Solution
Parameter settings are not appropriate for the load	Check L6-02 and L6-03 settings.
Fault on the machine side (e.g., machine is locked up)	Check the status of the load. Remove the cause of the fault.

5.3 Fault Detection

HOA Keypad Display	Fault Name
oL4	Overtorque Detection 2 The current has exceeded the value set for Overtorque Detection 2 (L6-05) for longer than the allowable time (L6-06).
Cause	Possible Solution
Parameter settings are not appropriate for the load	Check the settings of parameters L6-05 and L6-06.

HOA Keypad Display	Fault Name
oPr	External HOA Keypad Connection Fault The HOA keypad has been disconnected from the drive. Note: An oPr fault will occur when all of the following conditions are true: • Output is interrupted when the keypad is disconnected (o2-06 = 1). • The Run command is assigned to the keypad (b1-02 = 0 and LOCAL has been selected).
Cause	Possible Solution
HOA keypad is not properly connected to the drive	<ul style="list-style-type: none"> • Check the connection between the keypad and the drive. • Replace the cable if damaged. • Turn off the drive input power and disconnect the keypad. Reconnect the keypad and reapply drive input power.

HOA Keypad Display	Fault Name
ov	Control Circuit Overvoltage Voltage in the control circuit has exceeded the overvoltage level. • For 200 V class drives: approximately 450 V • For 400 V class drives: approximately 900 V
Cause	Possible Solution
Ground fault in the output circuit causing the capacitor to overcharge.	<ul style="list-style-type: none"> • Check the motor wiring for ground faults. • Correct grounding shorts and reapply power.
Drive input power voltage is too high.	<ul style="list-style-type: none"> • Check the voltage. • Lower drive input power voltage within the limits listed in the specifications.
The capacity of the input power supply is too small.	Use a power supply that has at least twice the input capacity of the drive.
The input power supply repeatedly turned on and off over a short period of time.	Implement countermeasures so that chattering does not occur for the input power supply.
An I/O terminal is loose.	Check the tightening torque of the I/O terminals.
Chattering in the magnetic contactor (MC) installed between the drive output terminals and the motor.	Implement countermeasures so that chattering does not occur for the MC.
There is a phase loss or an imbalance in the interphase voltages of the input power supply.	Check the status of the input power supply and eliminate phase losses and imbalance.

HOA Keypad Display	Fault Name
PoC	Pump Over Cycle
Cause	Possible Solution
The pump has exceeded the number of cycles set in P2-10 in the time set in P2-11 and P2-12 is set to 2 (fault).	<ul style="list-style-type: none"> • Set the Pump Over Cycle fault characteristics in P2-10 and P2-11. • Drive response to this condition is controlled by P2-12, Over Cycling Mode. • Auto-restart of this fault is controlled by L5-52, Pump Over Cycle Fault Retry Selection. • Set the Pump Over Cycle automatic setpoint compensation in P2-12, Over Cycling Mode, P2-13, Setpoint Compensation, and P2-14, Maximum Setpoint Compensation.

HOA Keypad Display	Fault Name
SCF	Safety Circuit Fault Safety Circuit Fault is detected.
Cause	Possible Solution
The safety circuit is damaged.	Replace either the control board or the entire drive. For instructions on replacing the control board, contact Yaskawa or your nearest sales representative.

HOA Keypad Display	Fault Name
SEr	Too Many Speed Search Restarts
	The number of Speed Search restarts exceeded the value set to b3-19.
Cause	Possible Solution
Parameters related to Speed Search are set to the wrong values	<ul style="list-style-type: none"> Reduce the detection compensation gain during Speed Search (b3-10). Increase the current level when attempting Speed Search (b3-17). Increase the detection time during Speed Search (b3-18). Repeat Auto-Tuning.

HOA Keypad Display	Fault Name
SoH	Snubber Discharge Resistor Overheat
Cause	Possible Solution
<ul style="list-style-type: none"> The input power supply voltage is too high. The capacity of the power supply is too small. The distortion in the power supply is too large. 	<ul style="list-style-type: none"> Reduce the voltage to within the range in the power supply specifications. Increase the capacity of the power supply. Lower the impedance of the input power supply wiring.
The load was too large during repetitious operation.	<ul style="list-style-type: none"> Check the load conditions. Reduce the load. Increase the acceleration/deceleration time.
A phase loss occurred in the input power supply.	Check the input power supply for phase loss or an imbalance in the interphase voltages.

HOA Keypad Display	Fault Name
SPL Suction Pressure Loss	Suction Pressure Loss
	Wire-break detection for suction pressure.
Cause	Possible Solution
An analog input programmed for setting 23 "WaterLvl/Suction" has dropped below 3 mA or risen above 21 mA for longer than 1 second.	Repair pressure sensor or wiring.

HOA Keypad Display	Fault Name
SrC	Phase Order Detection Fault
	The phase rotation direction for the input power supply changed.
Cause	Possible Solution
The power supply phase order changed during operation.	Investigate and correct the cause and reset the fault.
An input power supply wiring terminal is loose.	
The fluctuation in the voltage of the input power supply is too large.	

HOA Keypad Display	Fault Name
Srr	Internal Resistance Fault
	An operation failure occurred in the snubber discharge resistor circuit.
Cause	Possible Solution
The snubber discharge resistor or peripheral circuits failed.	<ul style="list-style-type: none"> Cycle power to the drive. If the problem continues, replace either the control board or the entire drive. For instructions on replacing the control board, contact Yaskawa or your nearest sales representative.

HOA Keypad Display	Fault Name
TdE	Time Data Error
Cause	Possible Solution
An error has occurred in the Real-Clock Time function of the HOA keypad.	Replace the HOA keypad. For instructions on replacing the HOA keypad, contact Yaskawa or your nearest sales representative.

5.3 Fault Detection

HOA Keypad Display	Fault Name
TIE	Time Interval Error
Cause	Possible Solution
An error has occurred in the Real-Time Clock function of the HOA keypad.	Replace the HOA keypad. For instructions on replacing the HOA keypad, contact Yaskawa or your nearest sales representative.

HOA Keypad Display	Fault Name
TIM	Time Not Set
Cause	Possible Solution
The Real-Time Clock for the HOA keypad is not set in parameter o4-17 and a feature that requires RTC information is enabled. <ul style="list-style-type: none"> The drive is a new drive, first power-up condition o4-17 was set to 2, Reset, by the user, manually clearing the Real-Time Clock data. 	Set o4-17 to 1 to set the time for the HOA keypad. The drive will display the "Clock Not Set" alarm when the Real-Time Clock is not set. Additionally, at power up, if the "TIM" condition is present, the drive will automatically switch to the time setting screen (o4-17 = 1) for 30 seconds to prompt the user to set the Real-Time Clock.
The user did not set the Real-Time Clock when prompted following power-up.	Cycle power to the drive and set the Real-Time Clock within 30 seconds of power-up, or set the clock manually via parameter o4-17.
The HOA keypad battery is low or the battery has been replaced.	Replace the HOA keypad battery and set the Real-Time Clock.
An error has occurred in the Real-Time Clock function of the HOA keypad.	Replace the HOA keypad. For instructions on replacing the HOA keypad, contact Yaskawa or your nearest sales representative.

HOA Keypad Display	Fault Name
UL3	Undertorque Detection 1 The current has fallen below the minimum value set for torque detection (L6-02) for longer than the allowable time (L6-03).
Cause	Possible Solution
Parameter settings are not appropriate for the load	Check the settings of parameters L6-02 and L6-03.
There is a fault on the machine side	Check the load for any problems.

HOA Keypad Display	Fault Name
UL4	Undertorque Detection 2 The current has fallen below the minimum value set for torque detection (L6-05) for longer than the allowable time (L6-06).
Cause	Possible Solution
Parameter settings are not appropriate for the load	Check L6-05 and L6-06 settings
There is a fault on the machine side	Check the load for any problems.

HOA Keypad Display	Fault Name
UL6	Motor Underload The load has fallen below the underload curve defined in L6-14.
Cause	Possible Solution
The output current has fallen below the motor underload curve defined in L6-14 for longer than the time set to L6-03	Adjust the value set to L6-14 so that output current remains above the motor underload curve during normal operation.

HOA Keypad Display	Fault Name
Uv1	Control Circuit Undervoltage Fault Voltage in the control circuit fell below the detection level: <ul style="list-style-type: none"> For 200 V class drives: approximately 175 V For 400 V class drives: approximately 350 V
Cause	Possible Solution
Input power phase loss	<ul style="list-style-type: none"> The main circuit drive input power is wired incorrectly. Correct the wiring.

HOA Keypad Display	Fault Name
One of the drive input power wiring terminals is loose	<ul style="list-style-type: none"> Ensure there are no loose terminals. Apply the tightening torque specified in this manual to fasten the terminals. <i>Refer to Main Circuit Wire Gauges and Tightening Torque on page 86</i> for details.
There is a problem with the voltage from the drive input power	<ul style="list-style-type: none"> Check the voltage. Correct the voltage to be within the range listed in drive input power specifications. If there is no problem with the power supply to the main circuit, check for problems with the main circuit magnetic contactor.
The power has been interrupted	Correct the drive input power.
The capacitors are worn.	<ul style="list-style-type: none"> Check the maintenance time for the capacitors (U4-05). Replace the entire drive if U4-05 exceeds 90%. Contact Yaskawa or your nearest sales representative.
The relay or contactor on the soft-charge bypass circuit is damaged.	<ul style="list-style-type: none"> Cycle power to the drive. If the problem continues, replace the entire drive. Contact Yaskawa or your nearest sales representative. Check monitor U4-06 for the performance life of the soft-charge bypass. Replace the entire drive if U4-06 exceeds 90%. Contact Yaskawa or your nearest sales representative.

HOA Keypad Display	Fault Name
Uv2	Control Power Supply Voltage Fault
	Voltage is too low for the control drive input power.
Cause	Possible Solution
Control power supply wiring is damaged	<ul style="list-style-type: none"> Cycle power to the drive. If the problem continues, replace the entire drive or the control power supply.
Internal circuitry is damaged	<ul style="list-style-type: none"> Cycle power to the drive. If the problem continues, replace the entire drive. Contact Yaskawa or your nearest sales representative.

HOA Keypad Display	Fault Name
Uv3	Undervoltage 3 (Soft-Charge Bypass Circuit Fault)
	The soft-charge bypass circuit failed.
Cause	Possible Solution
The relay or contactor on the soft-charge bypass circuit is damaged	<ul style="list-style-type: none"> Cycle power to the drive. If the problem continues, replace the entire drive. Contact Yaskawa or your nearest sales representative. Check monitor U4-06 for the performance life of the soft-charge bypass. Replace the entire drive if U4-06 exceeds 90%. Contact Yaskawa or your nearest sales representative.

HOA Keypad Display	Fault Name
VLTS	Volute-Thermostat Fault
Cause	Possible Solution
The digital input assigned to the volute/thermostat input (H1-0□ = 88 or 89) is active.	Check the wiring or wait for the volute or motor to cool.
Both volute/thermostat inputs are programmed simultaneously (H1-0□ = 88 and 89).	<ul style="list-style-type: none"> Program only one digital input to either H1-0□ = 88 or H1-0□ = 89. Auto-restart of this fault is controlled by parameter L5-53, Volute-TStat Retry Selection.

HOA Keypad Display	Fault Name
WLL Water Level Loss	Water Level Loss
Cause	Possible Solution
An analog input programmed for setting 23 "WaterLvl/Suction" has dropped below 3 mA or risen above 21 mA for longer than 1 second.	Repair level sensor or wiring.

5.4 Alarm Detection

◆ Alarm Codes, Causes, and Possible Solutions

Alarms are drive protection functions that do not necessarily cause the drive to stop. After removing the cause of an alarm, the drive will return to the same status it was before the alarm occurred.

When an alarm has been triggered, the ALM light on the HOA keypad display blinks and the alarm code display flashes. If a multi-function output is set for an alarm (H2-□□ = 10), that output terminal will be triggered.

Note: If a multi-function output is set to close when an alarm occurs (H2-□□ = 10), it will also close when maintenance periods are reached, triggering alarms LT-1 through LT-4 (triggered only if H2-□□ = 2F).

Table 5.5 Alarm Codes, Causes, and Possible Solutions

HOA Keypad Display	Minor Fault Name
ACCUM Accum Level	Accumulated Level Error
Cause	Possible Solution
The accumulated level has exceeded the values set in P6-11 to P6-14. This is only effective when P6-15, Accumulated Behavior is set to 1 (alarm).	Set the Accumulated Level fault characteristics in P6-11 to P6-14 and P6-16. Drive response to this condition is controlled by P6-15, Accumulated Behavior. Auto-restart of this fault is controlled by P6-15, Accumulated Behavior and P6-05, Flow Accumulation Reset.
HOA Keypad Display	Minor Fault Name
Accum Lvl Reached Cycle Run Cmd	Flow Accumulation level reached
Cause	Possible Solution
Accum Behavior P6-15 is set to 5 (Stop, Alarm, & Reset) and the Accumulated Level has been reached.	Cycle the Run command.
HOA Keypad Display	Minor Fault Name
AEr	Station Address Setting Error (CC-Link, CANopen, MECHATROLINK)
Cause	Possible Solutions
Station number is set outside the possible setting range.	<ul style="list-style-type: none"> Set parameter F6-10 to the proper value when using a CC-Link option. Set parameter F6-35 to the proper value when using a CANopen option.
HOA Keypad Display	Minor Fault Name
Anti-Jam Active	Anti-Jam Alarm
Cause	Possible Solution
The drive was not able to clear debris from the impeller in fewer than the attempts set in P7-02. This is only effective when P7-01, Anti-jam Operation is set to 1 (enabled).	<ul style="list-style-type: none"> Check for proper pump operation. Set the Anti-jam fault characteristics in P7-02 to P7-08. Drive response to this condition is controlled by P7-01, Anti-jam Operation Selection.
HOA Keypad Display	Minor Fault Name
AUv	Power Supply Undervoltage
Cause	Possible Solution
The power supply voltage is low.	Increase the power supply voltage.
A phase loss occurred in the input power supply.	Check the input power supply for phase loss or an imbalance in the interphase voltages. Investigate and correct the cause and then reset the fault.
HOA Keypad Display	Minor Fault Name
AUXFB PI Aux Lvl Loss	Wire-break detection for PI Aux Feedback Level
Cause	Possible Solution

HOA Keypad Display	Minor Fault Name
The analog input programmed for “PI Aux FB Level” (H3-□□ = 27) has dropped below 3 mA or risen above 21 mA for longer than 1 second.	Repair transducer or wiring.

HOA Keypad Display	Minor Fault Name
Backup FdBk Lost Check/Replace	Backup Feedback Device (H3-□□ = 24) lost.
Cause	Possible Solution
Wire-break on Analog Input Terminal programmed for Backup PI Feedback (H3-□□ = 24)	Check the connection of the Backup Feedback transducer.
Backup PI Feedback Transducer is broken.	Replace Backup PI Feedback Transducer.

HOA Keypad Display	Minor Fault Name
bAT	Keypad Battery Voltage Low
Cause	Possible Solution
The keypad battery is low	Replace the keypad battery.

HOA Keypad Display	Minor Fault Name
bb	Baseblock
	Drive output interrupted as indicated by an external baseblock signal.
Cause	Possible Solution
External baseblock signal was entered via one of the multi-function input terminals (S1 to S8).	Check external sequence and baseblock signal input timing.

HOA Keypad Display	Minor Fault Name
boL	Braking Transistor Overload Fault
	The braking transistor in the drive has been overloaded.
Cause	Possible Solution
The proper braking resistor has not been installed.	Select the proper braking resistor.

HOA Keypad Display	Minor Fault Name
bUS	Option Communication Error
	<ul style="list-style-type: none"> The connection was lost after initial communication was established. Assign a Run command frequency reference to the option.
Cause	Possible Solution
Connection is broken or master controller stopped communicating.	<ul style="list-style-type: none"> Check for faulty wiring. Correct the wiring. Check for disconnected cables and short circuits. Repair as needed.
Option is damaged.	If there are no problems with the wiring and the fault continues to occur, replace the option.
The option is not properly connected to the drive.	<ul style="list-style-type: none"> The connector pins on the option are not properly lined up with the connector pins on the drive. Reinstall the option.
A data error occurred due to noise.	<ul style="list-style-type: none"> Check options available to minimize the effects of noise. Take steps to counteract noise in the control circuit wiring, main circuit lines and ground wiring. Try to reduce noise on the controller side. Use surge absorbers on magnetic contactors or other equipment causing the disturbance. Use recommended cables or some other type of shielded line. Ground the shield to the controller side or on the input power side. Separate the wiring for communication devices from the drive input power lines. Install an EMC noise filter to the drive input power.

HOA Keypad Display	Minor Fault Name
CALL	Serial Communication Transmission Error
	Communication has not yet been established.
Cause	Possible Solution

5.4 Alarm Detection

HOA Keypad Display	Minor Fault Name
Communications wiring is faulty, there is a short circuit, or something is not connected properly.	<ul style="list-style-type: none"> • Check for wiring errors. • Correct the wiring. • Check for disconnected cables and short circuits. Repair as needed.
Programming error on the master side.	Check communications at start-up and correct programming errors.
Communications circuitry is damaged.	<ul style="list-style-type: none"> • Perform a self-diagnostics check. • If the problem continues, replace either the control board or the entire drive. For instructions on replacing the control board, contact Yaskawa or your nearest sales representative.
Termination resistor setting is incorrect.	Install a termination resistor at both ends of a communication line. Set the internal termination resistor switch correctly on slave drives. Place DIP switch S2 to the ON position.

HOA Keypad Display	Minor Fault Name
CE	MEMOBUS/Modbus Communication Error
	Control data was not received correctly for two seconds.
Cause	Possible Solution
A data error occurred due to noise.	<ul style="list-style-type: none"> • Check options available to minimize the effects of noise. • Take steps to counteract noise in the control circuit wiring, main circuit lines, and ground wiring. • Reduce noise on the controller side. • Use surge absorbers for the magnetic contactors or other components that may be causing the disturbance. • Use only recommended shielded line. Ground the shield on the controller side or on the drive input power side. • Separate all wiring for communication devices from drive input power lines. Install an EMC noise filter to the drive input power supply.
Communication protocol is incompatible.	<ul style="list-style-type: none"> • Check the H5 parameter settings and the protocol setting in the controller. • Ensure settings are compatible.
The CE detection time (H5-09) is set shorter than the time required for a communication cycle to take place.	<ul style="list-style-type: none"> • Check the PLC. • Change the software settings in the PLC. • Set a longer CE detection time using parameter H5-09.
Incompatible PLC software settings or there is a hardware problem.	<ul style="list-style-type: none"> • Check the PLC. • Remove the cause of the error on the controller side.
Communications cable is disconnected or damaged.	<ul style="list-style-type: none"> • Check the connector to make sure the cable has a signal. • Replace the communications cable.

HOA Keypad Display	Minor Fault Name
CE – Comm Loss Run at H5-14	MEMOBUS/Modbus Communicator Error. Drive runs at H5-14.
Cause	Possible Solution
A data error occurred due to noise.	<ul style="list-style-type: none"> • Check options available to minimize the effects of noise. • Take steps to counteract noise in the control circuit wiring, main circuit lines, and ground wiring. • Reduce noise on the controller side. • Use surge absorbers for the magnetic contactors or other components that may be causing the disturbance. • Use only recommended shielded line. Ground the shield on the controller side or on the drive input power side. • Separate all wiring for communication devices from drive input power lines. Install an EMC noise filter to the drive input power supply.
Communication protocol is incompatible.	<ul style="list-style-type: none"> • Check the H5 parameter settings and the protocol setting in the controller. • Ensure settings are compatible.
The CE detection time (H5-09) is set shorter than the time required for a communication cycle to take place.	<ul style="list-style-type: none"> • Check the PLC. • Change the software setting in the PLC. • Set a longer CE detection time using parameter H5-09.
Incompatible PLC software settings or there is a hardware problem.	<ul style="list-style-type: none"> • Check the PLC. • Remove the cause of the error on the controller side.
Communications cable is disconnected or damaged.	<ul style="list-style-type: none"> • Check the connector to make sure the cable has a signal. • Replace the communications cable.

HOA Keypad Display	Minor Fault Name
CrST	Cannot Reset
Cause	Possible Solutions
Fault reset was being executed when a Run command was entered.	<ul style="list-style-type: none"> Ensure that a Run command cannot be entered from the external terminals or option during fault reset. Turn off the Run command.

HOA Keypad Display	Minor Fault Name
Current Limit Foldback	Current Limit Foldback
Cause	Possible Solution
Drive output speed is being limited due to the output current limit.	<ul style="list-style-type: none"> Reduce the load. Verify setting of Q3-02. Change to a larger drive size.

HOA Keypad Display	Minor Fault Name
CyC	MECHATROLINK Comm. Cycle Setting Error
	Comm. Cycle Setting Error was detected.
Cause	Possible Solutions
The controller is using a comm. cycle beyond the allowable setting range for the MECHATROLINK option.	Set the comm. cycle for the upper controller within the allowable setting range for the MECHATROLINK option.

HOA Keypad Display	Minor Fault Name
De-Scale/De-rag Active	De-scale is running
Cause	Possible Solution
De-scale is programmed and enough run time has been accumulated.	If De-scale/De-rag is not desired, program P8-01 = 0 (Disabled). Adjust the De-scale Run Timer P8-08.

HOA Keypad Display	Minor Fault Name
Differential FB Detected	Differential Feedback Detected
Cause	Possible Solution
The difference between the PID Feedback and the Differential Feedback (H3-□□ = 28) exceeded the P4-18 level for the time set in P4-19.	<ul style="list-style-type: none"> Replace the feedback transducer or transducers. Verify parameter settings P4-18 to P4-20.

HOA Keypad Display	Minor Fault Name
dnE	Drive Disabled
Cause	Possible Solution
“Drive Enable” is set to a multi-function contact input (H1-□□ = 6A) and the contact is open.	Check the operation sequence.

HOA Keypad Display	Minor Fault Name
doH	Damping Resistor Overheat
	The temperature of the built-in damping resistor exceeded the set value.
Cause	Possible Solution
<ul style="list-style-type: none"> The capacity of the power supply is too small. The distortion in the power supply is too large. 	<ul style="list-style-type: none"> Increase the capacity of the power supply. Lower the impedance of the input power supply wiring.
A phase loss occurred in the input power supply.	Check the input power supply for phase loss or an imbalance in the interphase voltages.

HOA Keypad Display	Minor Fault Name
EF	Forward/Reverse Run Command Input Error
	Both forward run and reverse run closed simultaneously for longer than 0.5 s.

5.4 Alarm Detection

HOA Keypad Display	Minor Fault Name
Cause	Possible Solution
Sequence error	Check the forward and reverse command sequence and correct the problem. Note: When minor fault EF detected, motor ramps to stop.

HOA Keypad Display	Minor Fault Name
EF0	Option Card External Fault An external fault condition is present.
Cause	Possible Solution
An external fault was received from the PLC with F6-03 set to 3, which allows the drive to continue running after an external fault occurs.	<ul style="list-style-type: none"> Remove the cause of the external fault. Remove the external fault input from the PLC.
There is a problem with the PLC program.	Check the PLC program and correct problems.

HOA Keypad Display	Minor Fault Name
EF1	Pump Fault (Input Terminal S1)
	External fault at multi-function input terminal S1.
EF2	Pump fault (input terminal S2)
	External fault at multi-function input terminal S2.
EF3	Pump fault (input terminal S3)
	External fault at multi-function input terminal S3.
EF4	Pump fault (input terminal S4)
	External fault at multi-function input terminal S4.
EF5	Pump fault (input terminal S5)
	External fault at multi-function input terminal S5.
EF6	Pump fault (input terminal S6)
	External fault at multi-function input terminal S6.
EF7	Pump fault (input terminal S7)
	External fault at multi-function input terminal S7.
EF8	Pump fault (input terminal S8)
	External fault at multi-function input terminal S8.
Cause	Possible Solutions
An external device has tripped an alarm function.	Remove the cause of the external fault and reset the multi-function input value.
Wiring is incorrect.	<ul style="list-style-type: none"> Ensure the signal lines have been connected properly to the terminals assigned for pump fault detection (H1-□□ = 20 to 2F). Reconnect the signal line.
Multi-function contact inputs are set incorrectly.	<ul style="list-style-type: none"> Check if the unused terminals have been set for H1-□□ = 20 to 2F (Pump Fault). Change the terminal settings.

HOA Keypad Display	Minor Fault Name
FAn	Internal Fan Error
	Fan or magnetic contactor failure
Cause	Possible Solution
Internal cooling fan has malfunctioned	<ul style="list-style-type: none"> Cycle power to the drive. Check for fan operation. Verify the cumulative operation time of the fan with monitor U4-03, and verify the cumulative operation time of the fan maintenance timer with U4-04. If the cooling fan has exceeded its expected performance life or is damaged in any other way, follow the replacement instructions in the <i>Peripheral Devices & Options</i> chapter.
Fault detected in the internal cooling fan or magnetic contactor to the power supply.	<ul style="list-style-type: none"> Cycle power to the drive. If the fault continues to occur, replace the power board/gate drive board or the entire drive. Contact Yaskawa or a Yaskawa representative for instructions on replacing the power board/gate drive board.

HOA Keypad Display	Minor Fault Name
Fdv	Power Supply Frequency Fault The input power supply frequency exceeded the allowable frequency fluctuation.
Cause	Possible Solution
A momentary power loss occurred.	Reset the fault.
An input power supply wiring terminal is loose.	Check for loose terminals.
The fluctuation in the voltage of the input power supply is too large.	Increase the Power Supply Frequency Fault Detection Width (L2-27).
The built-in fuse is open.	Replace either the control board or the entire drive. For instructions on replacing the control board, contact Yaskawa or your nearest sales representative.
The phase rotation direction has changed in the input power supply.	Correct the wiring.
The detected power supply frequency exceeded the allowable value.	Improve the power supply.

HOA Keypad Display	Minor Fault Name
Feedback Loss Go To Freq. b5-13	PI Feedback Loss The drive will run at the speed set in b5-13, Feedback Loss Goto Frequency.
Cause	Possible Solutions
PI feedback source is incorrectly installed or is not working. Effective only when b5-12 is set to 3 (Run at b5-13).	<ul style="list-style-type: none"> Confirm that the PID feedback source is installed and working properly. Drive response to this condition is controlled by b5-12, Feedback Loss 4 to 20 mA Detection Selection, and b5-13, Feedback Loss Go To Frequency.

HOA Keypad Display	Minor Fault Name
Feedback Loss Wire Break	PI Feedback Loss The analog input programmed for PID feedback has gone above 21 mA or fallen below 3 mA.
Cause	Possible Solutions
PI feedback source is incorrectly installed or is not working. This is effective only when b5-12 Feedback Loss 4 to 20 mA Detection Selection is set to 1 (alarm).	<ul style="list-style-type: none"> Confirm that the PID feedback source is installed and working properly. Drive response to this condition is controlled by b5-12, Feedback Loss 4 to 20 mA Detection Selection, and b5-13, Feedback Loss Go To Frequency. Auto-restart of this fault is controlled by L5-42, Feedback Loss Fault Retry Selection.

HOA Keypad Display	Minor Fault Name
Freq. Ref Pump Min (P1-06)	Minimum Pump Frequency Reference Drive frequency reference is set lower than P1-06, Minimum Pump Frequency.
Cause	Possible Solutions
The frequency reference is set lower than P1-06. The frequency reference is internally set to the P1-06 value during this time. This will only be active when the following conditions are true: <ul style="list-style-type: none"> Drive is NOT in PI Mode Minimum Pump Frequency is enabled (P1-06 > 0.00) 	Increase the frequency reference to a value greater than P1-06.

HOA Keypad Display	Minor Fault Name
Freq. Ref Thrust (P4-12)	Thrust Frequency Reference The fixed frequency reference is set to a value lower than the P4-12, Thrust Frequency, setting.
Cause	Possible Solutions
The frequency reference is set lower than P4-12. The frequency reference is internally set to the P4-12 value during this time. This will only be active when the following conditions are true: <ul style="list-style-type: none"> Drive is NOT in PI Mode Thrust bearing is enabled (P4-12 > 0.00) 	Increase the frequency reference to a value greater than P4-12.

5.4 Alarm Detection

HOA Keypad Display	Minor Fault Name
Hbb	Safe Disable Signal Input
	Both Safe Disable Input channels are open.
Cause	Possible Solution
Both Safe Disable Inputs H1 and H2 are open.	<ul style="list-style-type: none"> • Check signal status at the input terminals H1 and H2. • Check the Sink/Source Selection for the digital inputs. • If the Safe Disable function is not utilized, determine if terminals H1-HC, and H2-HC are linked.
Internally, both Safe Disable channels are broken.	Replace either the control board or the entire drive. For instructions on replacing the control board, contact Yaskawa or your nearest sales representative.

HOA Keypad Display	Minor Fault Name
HbbF	Safe Disable Signal Input
	One Safe Disable channel is open while the other channel is closed.
Cause	Possible Solution
The signals to the Safe Disable inputs are wrong or the wiring is incorrect.	Check signal status at the input terminals H1 and H2. If the Safe Disable function is not utilized, terminals H1-HC, and H2-HC must be linked.
One of the Safe Disable channels is faulty.	Replace either the control board or the entire drive. For instructions on replacing the control board, contact Yaskawa or your nearest sales representative.

HOA Keypad Display	Minor Fault Name
HCA	Current Alarm
	Drive current exceeded overcurrent warning level (150% of the rated current).
Cause	Possible Solutions
Load is too heavy.	Reduce the load for applications with repetitive operations (i.e., stops and starts), or replace the drive.
Acceleration and deceleration times are too short.	<ul style="list-style-type: none"> • Calculate the torque required during acceleration and for the inertia moment. • If the torque level is not right for the load, take the following steps: <ul style="list-style-type: none"> • Increase the acceleration and deceleration times (C1-01 through C1-04). • Increase the capacity of the drive.
A special-purpose motor is being used, or the drive is attempting to run a motor greater than the maximum allowable capacity.	<ul style="list-style-type: none"> • Check the motor capacity. • Use a motor appropriate for the drive. Ensure the motor is within the allowable capacity range.
The current level increased due to Speed Search after a momentary power loss or while attempting to perform a fault restart.	The alarm will only appear briefly. There is no need to take action to prevent the alarm from occurring in such instances.

HOA Keypad Display	Minor Fault Name
HIAUX High PI Aux Lvl	High PI Auxiliary Feedback Level
Cause	Possible Solution
PI Aux Feedback has risen above the Q6-12 level for longer than the time set in Q6-13 and the drive is running in AUTO, and output frequency is greater than zero.	<ul style="list-style-type: none"> • Lower the PI Aux Feedback level • Adjust parameters Q6-12 and Q6-13.

HOA Keypad Display	Minor Fault Name
HIFLO High Flow	High Flow Error
	The meter has detected a high flow condition.
Cause	Possible Solution
The flow is too high	Reduce the flow
The measured water flow has risen above the P6-17 level for the time set in P6-18. This is only effective when P6-19, High Flow Select is set to 1 (alarm).	<ul style="list-style-type: none"> • Set the High Flow fault characteristics in P6-17 and P6-18. • Drive response to this condition is controlled by P6-19, High Flow Select. • Auto-restart of this fault is controlled by P6-19, High Flow Select.

HOA Keypad Display	Minor Fault Name
High Feedback High FB Sensed	High Feedback Level Alarm
	The feedback signal is too high.
Cause	Possible Solutions

HOA Keypad Display	Minor Fault Name
The feedback level has risen above the level set in P1-11, High Feedback Level This is only effective when P1-13, High Feedback Selection, is set to 1 (Alarm and digital out).	<ul style="list-style-type: none"> Decrease the feedback signal. Set the High Feedback alarm characteristics in P1-11 and P-12. Drive response to this condition is controlled by P1-13, High Feedback Selection.
HOA Keypad Display	Minor Fault Name
HISUC High Suction	High Section Pressure
Cause	Possible Solution
The suction pressure has fallen below the level set in Q5-12. This is only effective when Q5-14, High Suction Pressure Behavior Select is set to 1 (alarm).	<ul style="list-style-type: none"> Reduce the system pressure. Set the High Suction Pressure alarm characteristics in Q5-12. Drive response to this condition is controlled by Q5-14, High Suction Pressure Behavior Select. Auto-restart of this fault is controlled by Q5-14, High Suction Pressure Behavior Select and Q5-15, Suction Pressure Auto-restart Time.
HOA Keypad Display	Minor Fault Name
LOAUX Low PI Aux Lvl	Low PI Auxiliary Feedback Level
Cause	Possible Solution
PI Aux Feedback has fallen below the Q6-09 level for longer than the time set in Q6-10 and the drive is running in HAND or AUTO.	<ul style="list-style-type: none"> Raise the PI Aux Feedback level Adjust parameters Q6-09 and Q6-10.
HOA Keypad Display	Minor Fault Name
LOP	Loss of Prime
	The pump has lost its prime and P1-22 is set to 1.
Cause	Possible Solution
The measured quantity of water has dropped below the level set in P1-19, Prime Loss Level, for the time set in P1-20, Loss of Prime Time, and the output frequency has risen above P1-21, Prime Loss Frequency. This could be due to a dry well, air in the system, or no water in the system. This is effective only when P1-22 Loss of Prime Selection is set to 1 (alarm).	<ul style="list-style-type: none"> If there is resistance in the pump, allow the system to pump water again. Set the Loss of Prime alarm characteristics in P1-18, P1-19, P1-20, and P1-21. Drive response to this condition is controlled by P1-21, Loss of Prime Selection.
HOA Keypad Display	Minor Fault Name
LOSUC Low Suction	Low Section Pressure
Cause	Possible Solution
The suction pressure has fallen below the level set in Q5-09 for longer than the time set in Q5-10. This is only effective when Q5-11, Low Suction Pressure Behavior Select is set to 1 (alarm).	<ul style="list-style-type: none"> Increase the system pressure. Set the Low Suction alarm characteristics in Q5-09, Q5-10, and Q5-18. Q5-10 Detection Delay Time only applies if Q5-01 = 2. Drive response to this condition is controlled by Q5-11, Low Suction Pressure Behavior Select.
HOA Keypad Display	Minor Fault Name
Low City Pressure	Low City Pressure
Cause	Possible Solution
Insufficient pressure is present on the inlet to the pump. Shown when P4-24 = 0 and when the digital input has been active (closed for P4-21 = 0, or open for P4-21 = 1) for the time set in P4-22.	<ul style="list-style-type: none"> Check pressure switch contact for correct operation. Check control wiring to drive terminal strip from pressure switch contact. Check to make sure that suction pressure is present by means of a separate measuring device.
HOA Keypad Display	Minor Fault Name
Low Feedback Low FB Sensed	Low Feedback Level Alarm
	The feedback signal is too low.
Cause	Possible Solutions

5.4 Alarm Detection

HOA Keypad Display	Minor Fault Name
The feedback level has dropped below the level set in P1-08, Low Feedback Level. This is only effective when P1-10, Low Feedback Selection, is set to 1 (Alarm and digital out).	<ul style="list-style-type: none"> • Increase the feedback signal. • Set the Low Feedback alarm characteristics in P1-08 and P1-09. • Drive response to this condition is controlled by P1-10, Low Feedback Selection.

HOA Keypad Display	Minor Fault Name
LOWFL Low Flow	Low Flow
Cause	Possible Solution
Insufficient flow	Increase flow
After waiting the P6-08 delay time at start, the measured water flow has fallen below the P6-06 level for the time set in P6-07. This is only effective when P6-09, Low Flow Select is set to 1 (Alarm only).	<ul style="list-style-type: none"> • Set the Low Flow fault characteristics in P6-06, P6-07, and P6-08. • Drive response to this condition is controlled by P6-09, Low Flow Select. • Auto-restart of this fault is controlled by P6-09, Low Flow Select and P6-10, Low Flow Auto-restart Time.

HOA Keypad Display	Minor Fault Name
Low Suction Pressure	Low Suction Pressure
Cause	Possible Solution
Insufficient suction pressure is present. Shown when P4-24 = 1 and when the digital input has been active (closed for P4-21 = 0, or open for P4-21 = 1) for the time set in P4-22.	<ul style="list-style-type: none"> • Check pressure switch contact for correct operation. • Check control wiring to drive terminal strip from pressure switch contact. • Check to make sure that suction pressure is present by means of a separate measuring device. • Note: The following possible solutions apply to drive software versions PRG: 8551 and earlier. • Increase the system pressure. • Set the Low Suction alarm characteristics in Q5-09 and Q5-18. • Drive response to this condition is controlled by Q5-11, Low Suction Pressure Behavior Select.

HOA Keypad Display	Minor Fault Name
Low Water in Tank	Low Water in Tank
Cause	Possible Solution
Insufficient pressure is present on the inlet to the pump. Shown when P4-24 = 2 and when the digital input has been active (closed for P4-21 = 0, or open for P4-21 = 1) for the time set in P4-22.	<ul style="list-style-type: none"> • Check pressure switch contact for correct operation. • Check control wiring to drive terminal strip from pressure switch contact. • Check to make sure that suction pressure is present by means of a separate measuring device. • Raise the water level. • Set the Low Water Level alarm characteristics in Q4-09. • Drive response to this condition is controlled by Q4-11, Low Level Behavior.

HOA Keypad Display	Minor Fault Name
LOWWL Low Water Level	Low Water Level
Cause	Possible Solution
The water level has fallen below the level set in Q4-09 for the longer than the time set in Q4-10. This is only effective when Q4-11, Low Level Behavior is set to 1 (Alarm).	<ul style="list-style-type: none"> • Raise the water level. • Set the Low Water Level fault characteristics in Q4-09 and Q4-10. • Drive response to this condition is controlled by Q4-11, Low Level Behavior. • Auto-restart of this fault is controlled by Q4-11, Low Level Behavior and Q4-12 Water Level Control Auto-restart Time.

HOA Keypad Display	Minor Fault Name
LT-1	Cooling Fan Maintenance Time
	The cooling fan has reached its expected maintenance period and may need to be replaced.
	Note: An alarm output (H2-□□ = 10) will only be triggered if both (H2-□□ = 2F and H2-□□ = 10) are set.
Cause	Possible Solution
The cooling fan has reached 90% of its expected performance life.	Replace the cooling fan and set o4-03 to 0 to reset the Maintenance Monitor.

HOA Keypad Display	Minor Fault Name
LT-2	Capacitor Maintenance Time
	The main circuit and control circuit capacitors are nearing the end of their expected performance life. Note: An alarm output (H2-□□ = 10) will only be triggered if H2-□□ = 2F.
Cause	Possible Solution
The main circuit and control circuit capacitors have reached 90% of their expected performance lives.	Replace either the control board or the entire drive. For instructions on replacing the control board, contact Yaskawa or your nearest sales representative.

HOA Keypad Display	Minor Fault Name
LT-3	Soft Charge Bypass Relay Maintenance Time
	The DC bus soft charge relay is nearing the end of its expected performance life. Note: An alarm output (H2-□□ = 10) will only be triggered if H2-□□ = 2F.
Cause	Possible Solution
The DC bus soft charge relay has reached 90% of expected performance life.	Replace either the control board or the entire drive. For instructions on replacing the control board, contact Yaskawa or your nearest sales representative.

HOA Keypad Display	Minor Fault Name
LT-4	IGBT Maintenance Time (50%)
	IGBTs have reached 50% of their expected performance life. Note: An alarm output (H2-□□ = 10) will only be triggered if H2-□□ = 2F.
Cause	Possible Solution
IGBTs have reached 50% of their expected performance life.	Check the load, carrier frequency, and output frequency.

HOA Keypad Display	Minor Fault Name
Main FdBk Lost Using Backup FB	Main Feedback Device (H3-□□ = B) lost.
Cause	Possible Solution
Wire-break on Analog Input Terminal programmed for Primary PI Feedback (H3-□□ = B)	Check the connection of the Main Feedback transducer.
Main PI Feedback Transducer is broken.	Replace Main PI Feedback Transducer.

HOA Keypad Display	Minor Fault Name
NMS	Not Maintaining Setpoint
	The setpoint cannot be maintained and P1-17 is set to 1.
Cause	Possible Solution
When the feedback deviates from the setpoint at a level greater than P1-15, for a time set in P1-16. This is effective only when P1-17 is set to 1 (alarm).	<ul style="list-style-type: none"> • Check for a blocked impeller, over cycling, or broken pipe. • Set the Not Maintaining Setpoint alarm characteristics in P1-16 and P1-17. • Drive response to this condition is controlled by P1-17, Not Maintaining Setpoint Selection.

HOA Keypad Display	Minor Fault Name
oH	Heatsink Overheat
	The temperature of the heatsink exceeded the overheat pre-alarm level set to L8-02.
Cause	Possible Solution
Surrounding temperature is too high	<ul style="list-style-type: none"> • Check the surrounding temperature. • Improve the air circulation within the enclosure panel. • Install a fan or air conditioner to cool surrounding area. • Remove anything near drive that may cause extra heat.
Internal cooling fan has stopped.	<ul style="list-style-type: none"> • Replace the cooling fan. • After replacing the drive, set parameter o4-03 to 0 to reset the cooling fan operation time.
Airflow around the drive is restricted.	<ul style="list-style-type: none"> • Provide proper installation space around the drive as indicated in the manual. <i>Refer to Installation Orientation and Spacing on page 45</i> for details. • Allow for the proper space and ensure that there is sufficient circulation around the control panel. • Check for dust or other foreign materials clogging the cooling fan. • Clear debris caught in the fan that restricts air circulation.

5.4 Alarm Detection

HOA Keypad Display	Minor Fault Name
oH2	Drive Overheat Warning
	“Drive Overheat Warning” was input to a multi-function input terminal, S1 through S8 (H1-□□= B).
Cause	Possible Solution
An external device triggered an overheat warning in the drive.	Search for the device that tripped the overheat warning. Remove the cause of the problem.

HOA Keypad Display	Minor Fault Name
oH3	Motor Overheat
	The motor overheat signal entered to a multi-function analog input terminal exceeded the alarm level (H3-02, H3-06 or H3-10 = E).
Cause	Possible Solutions
Motor thermostat wiring is faulty (PTC input).	Repair the PTC input wiring.
There is a fault on the machine side (e.g., the machine is locked up).	<ul style="list-style-type: none"> • Check the status of the machine. • Remove the cause of the fault.
Motor has overheated.	<ul style="list-style-type: none"> • Check the load size, accel/decel times, and cycle times. • Decrease the load. • Increase accel and decel times (C1-01 to C1-04). • Adjust the preset V/f pattern (E1-04 through E1-10). This involves reducing E1-08 and E1-10. <p>Note: Refrain from lowering E1-08 and E1-10 excessively to prevent a reduction in load tolerance at low speeds.</p> <ul style="list-style-type: none"> • Check the motor-rated current. • Enter motor-rated current on motor nameplate (E2-01). • Ensure the motor cooling system is operating normally. • Repair or replace the motor cooling system.

HOA Keypad Display	Minor Fault Name
oL1	Motor Overload
	The electronic motor overload protection tripped
Cause	Possible Solution
Load is too heavy	Reduce the load.
Cycle times are too short during acceleration and deceleration	Increase the acceleration and deceleration times (C1-01 through C1-04).
A general-purpose motor is driven below the rated speed with a high load	<ul style="list-style-type: none"> • Reduce the load. • Increase the speed. • If the motor is supposed to operate at low speeds, either increase the motor capacity or use a motor specifically designed to operate in the desired speed range.
The output voltage is too high	<ul style="list-style-type: none"> • Adjust the user-set V/f pattern (E1-04 through E1-10) by reducing E1-08 and E1-10. • Do not set E1-08 and E1-10 too low. This reduces load tolerance at low speeds.
The wrong motor rated current is set to E2-01	<ul style="list-style-type: none"> • Check the motor-rated current. • Enter the motor rated current to parameter E2-01 as indicated on the motor nameplate.
The base frequency is set incorrectly	<ul style="list-style-type: none"> • Check the rated frequency indicated on the motor nameplate. • Enter the rated frequency to E1-06 (Base Frequency).
The electrical thermal protection characteristics and motor overload characteristics do not match	<ul style="list-style-type: none"> • Check the motor characteristics. • Correct the type of motor protection that has been selected (L1-01). • Install an external thermal relay.
The electrical thermal relay is operating at the wrong level	<ul style="list-style-type: none"> • Check the current rating listed on the motor nameplate. • Check the value set for the motor rated current (E2-01).
Motor overheated by overexcitation operation	<ul style="list-style-type: none"> • Overexcitation increases the motor loss and the motor temperature. Excessive duration of overexcitation may cause motor damage. Prevent excessive overexcitation operation or apply proper cooling to the motor. • Reduce the excitation deceleration gain (n3-13). • Set L3-04 (Stall Prevention during Deceleration) to a value other than 4.
Parameters related to Speed Search are set incorrectly	<ul style="list-style-type: none"> • Check values set to Speed Search related parameters. • Adjust the Speed Search current and Speed Search deceleration times (b3-02 and b3-03 respectively). • After Auto-Tuning, set b3-24 to 1 to enable Speed Estimation Speed Search.

HOA Keypad Display	Minor Fault Name
Output current fluctuation due to power supply loss	Check the power supply for phase loss.

HOA Keypad Display	Minor Fault Name
oL2	Drive Overload
	The thermal sensor of the drive triggered overload protection.
Cause	Possible Solution
Load is too heavy	Reduce the load.
Acceleration or deceleration time is too short	Increase the settings for the acceleration and deceleration times (C1-01 through C1-04).
The output voltage is too high	<ul style="list-style-type: none"> Adjust the preset V/f pattern (E1-04 through E1-10) by reducing E1-08 and E1-10. Do not lower E1-08 and E1-10 excessively. This reduces load tolerance at low speeds.
Drive capacity is too small	Replace the drive with a larger model.
Overload occurred when operating at low speeds	<ul style="list-style-type: none"> Reduce the load when operating at low speeds. Replace the drive with a model that is one frame size larger. Lower the carrier frequency (C6-02).
Excessive torque compensation	Reduce the torque compensation gain in parameter C4-01 until there is less current but no speed loss.
Parameters related to Speed Search are set incorrectly	<ul style="list-style-type: none"> Check the settings for all Speed Search related parameters. Adjust the current used during Speed Search (b3-03) and the Speed Search deceleration time (b3-02). After Auto-Tuning, set b3-24 to 1 to enable Speed Estimation Speed Search.
Output current fluctuation due to input phase loss	Check the power supply for phase loss.

HOA Keypad Display	Minor Fault Name
oL3	Overtorque Detection 1
	The current has exceeded the value set for torque detection (L6-02) for longer than the allowable time (L6-03).
Cause	Possible Solution
Parameter settings are not appropriate for the load	Check L6-02 and L6-03 settings.
Fault on the machine side (e.g., machine is locked up)	Check the status of the load. Remove the cause of the fault.

HOA Keypad Display	Minor Fault Name
oL4	Overtorque Detection 2
	The current has exceeded the value set for Overtorque Detection 2 (L6-05) for longer than the allowable time (L6-06).
Cause	Possible Solution
Parameter settings are not appropriate for the load	Check the settings of parameters L6-05 and L6-06.

HOA Keypad Display	Minor Fault Name
ov	Control Circuit Overvoltage
	Voltage in the control circuit has exceeded the overvoltage level. <ul style="list-style-type: none"> For 200 V class drives: approximately 450 V For 400 V class drives: approximately 900 V
Cause	Possible Solution
Ground fault in the output circuit causing the capacitor to overcharge.	<ul style="list-style-type: none"> Check the motor wiring for ground faults. Correct grounding shorts and reapply power.
Drive input power voltage is too high.	<ul style="list-style-type: none"> Check the voltage. Lower drive input power voltage within the limits listed in the specifications.
The capacity of the input power supply is too small.	Use a power supply that has at least twice the input capacity of the drive.
The input power supply repeatedly turned on and off over a short period of time.	Implement countermeasures so that chattering does not occur for the input power supply.
An I/O terminal is loose.	Check the tightening torque of the I/O terminals.

5.4 Alarm Detection

HOA Keypad Display	Minor Fault Name
Chattering in the magnetic contactor (MC) installed between the drive output terminals and the motor.	Implement countermeasures so that chattering does not occur for the MC.
There is a phase loss or an imbalance in the interphase voltages of the input power supply.	Check the status of the input power supply and eliminate phase losses and imbalance.
HOA Keypad Display	Minor Fault Name
PoC	Pump Over Cycle
Cause	Possible Solution
The pump has exceeded the number of cycles set in P2-10 in the time set in P2-11 and P2-12 is set to 1 (alarm).	<ul style="list-style-type: none"> Set the Pump Over Cycle alarm characteristics in P2-10 and P2-11. Drive response to this condition is controlled by P2-12, Over Cycling Mode.
HOA Keypad Display	Minor Fault Name
R-DNE-S□	Remote Drive Disable
Cause	Possible Solution
Terminal S□ (H1-0□ = 95) has been closed for the time set in P4-26, Remote Drive Disable On-Delay, when P4-25, Remote Drive Disable Selection, was set to 0 (N.O.).	Remove conditions causing the terminal to close.
Terminal S□ (H1-0□ = 95) has been open for the time set in P4-26, Remote Drive Disable On-Delay, when P4-25, Remote Drive Disable Selection, was set to 1 (N.C.).	Remove conditions causing the terminal to open.
HOA Keypad Display	Minor Fault Name
SE	MEMOBUS/Modbus Communication Test Mode Error
Cause	Possible Solution
A digital input set to 67H (MEMOBUS/Modbus test) was closed while the drive was running.	<p>Note: This alarm will not trigger a multi-function output terminal that is set for alarm output (H2-□□ = 10).</p> <p>Stop the drive and run the test again.</p>
HOA Keypad Display	Minor Fault Name
SPL Suction Pressure Loss	Suction Pressure Loss
Cause	Possible Solution
An analog input programmed for setting 23 “WaterLvl/Suction” has dropped below 3 mA or risen above 21 mA for longer than 1 second.	Wire-break detection for suction pressure. Repair pressure sensor or wiring.
HOA Keypad Display	Minor Fault Name
SrC	Phase Order Detection Fault
Cause	Possible Solution
An input power supply wiring terminal is loose. The fluctuation in the voltage of the input power supply is too large.	The phase rotation direction for the input power supply changed. Investigate and correct the cause and reset the fault.
HOA Keypad Display	Minor Fault Name
UL3	Undertorque Detection 1
Cause	Possible Solution
	The current has fallen below the minimum value set for torque detection (L6-02) for longer than the allowable time (L6-03).

HOA Keypad Display	Minor Fault Name
Parameter settings are not appropriate for the load	Check the settings of parameters L6-02 and L6-03.
There is a fault on the machine side	Check the load for any problems.

HOA Keypad Display	Minor Fault Name
UL4	Undertorque Detection 2
	The current has fallen below the minimum value set for torque detection (L6-05) for longer than the allowable time (L6-06).
Cause	Possible Solution
Parameter settings are not appropriate for the load	Check L6-05 and L6-06 settings
There is a fault on the machine side	Check the load for any problems.

HOA Keypad Display	Minor Fault Name
UL6	Motor Underload
	The load has fallen below the underload curve defined in L6-14.
Cause	Possible Solution
The output current has fallen below the motor underload curve defined in L6-14 for longer than the time set to L6-03	Adjust the value set to L6-14 so that output current remains above the motor underload curve during normal operation.

HOA Keypad Display	Minor Fault Name
Uv	Control Circuit Undervoltage
	One of the following conditions occurred: <ul style="list-style-type: none"> Contactor to suppress inrush current in the drive was opened. Low voltage in the control drive input power. This alarm outputs only if L2-01 is not 0 and DC bus voltage is under L2-05.
Cause	Possible Solution
Input power phase loss	<ul style="list-style-type: none"> The main circuit drive input power is wired incorrectly. Correct the wiring.
One of the drive input power wiring terminals is loose	<ul style="list-style-type: none"> Ensure there are no loose terminals. Apply the tightening torque specified in this manual to fasten the terminals. <i>Refer to Main Circuit Wire Gauges and Tightening Torque on page 86</i> for details.
There is a problem with the voltage from the drive input power	<ul style="list-style-type: none"> Check the voltage. Correct the voltage to be within the range listed in drive input power specifications. If there is no problem with the power supply to the main circuit, check for problems with the main circuit magnetic contactor.
The power has been interrupted	Correct the drive input power.
The capacitors are worn.	<ul style="list-style-type: none"> Check the maintenance time for the capacitors (U4-05). Replace the entire drive if U4-05 exceeds 90%. Contact Yaskawa or your nearest sales representative.
The drive input power transformer is too small and voltage drops when the power is switched on.	<ul style="list-style-type: none"> Check for an alarm when the magnetic contactor, line breaker, and leakage breaker are closed. Check the capacity of the drive input power transformer.

HOA Keypad Display	Minor Fault Name
WLL Water Level Loss	Water Level Loss
Cause	Possible Solution
An analog input programmed for setting 23 "WaterLvl/Suction" has dropped below 3 mA or risen above 21 mA for longer than 1 second.	Repair level sensor or wiring.

5.5 Operator Programming Errors

◆ Operator Programming Error Codes, Causes, and Possible Solutions

An Operator Programming Error (oPE) occurs when a contradictory parameter is set or an individual parameter is set to an inappropriate value.

The drive will not operate until the parameter or parameters causing the problem are set correctly. An oPE, however, does not trigger an alarm or fault output. If an oPE occurs, investigate the cause and refer to [Table 5.6](#) for the appropriate action. When an oPE appears on the operator display, press the ENTER button to view U1-18 and see which parameter is causing the oPE.

Table 5.6 oPE Codes, Causes, and Possible Solutions

HOA Keypad Display	Error Name
oPE01	Drive Capacity Setting Fault
	Drive capacity and the value set to o2-04 do not match.
Cause	Possible Solutions
The drive model selection (o2-04) and the actual capacity of the drive are not the same.	Correct the value set to o2-04.

HOA Keypad Display	Error Name
oPE02	Parameter Range Setting Error
	Use U1-18 to find parameters set outside the range.
Cause	Possible Solutions
Parameters were set outside the possible setting range.	Set parameters to the proper values.
Note: When multiple errors occur simultaneously, other errors are given precedence over oPE02.	

HOA Keypad Display	Error Name
oPE03	Multi-Function Input Selection Error
	A contradictory setting is assigned to multi-function contact inputs H1-01 to H1-08.
Cause	Possible Solutions
<ul style="list-style-type: none"> The same function is assigned to two multi-function inputs. Excludes “Not used” and “External Fault.” 	<ul style="list-style-type: none"> Ensure all multi-function inputs are assigned to different functions. Re-enter the multi-function settings to ensure this does not occur.
The Up command was set but the Down command was not, or vice versa (settings 10 vs. 11).	Properly set the functions that required for use in combination with other functions.
The Up 2 command was set but the Down 2 command was not, or vice versa (settings 75 vs. 76).	
<ul style="list-style-type: none"> Run/Stop command for a 2-wire sequence was set (H1-□□ = 42), but Forward/Reverse command (H1-□□ = 43) was not. “Drive Enable” is set to multi-function input S1 or S2 (H1-01 = 6A or H1-02 = 6A). 	Properly set the functions that required for use in combination with other functions.
Two of the following functions are set simultaneously: <ul style="list-style-type: none"> Up/Down Command (10 vs. 11) Up 2/Down 2 Command (75 vs. 76) Hold Accel/Decel Stop (A) Analog Frequency Reference Sample/Hold (1E) 	<ul style="list-style-type: none"> Check if contradictory settings have simultaneously been assigned to the multi-function input terminals. Correct setting errors.
The Up/Down command (10, 11) and PID control (b5-01) are enabled simultaneously.	Set b5-01 to 0 to disable control PID or disable the Up/Down command.

HOA Keypad Display	Error Name
<p>Settings for N.C. and N.O. input for the following functions were selected simultaneously:</p> <ul style="list-style-type: none"> External Search Command 1 and External Search Command 2 (61 vs. 62) Fast Stop N.O. and Fast Stop N.C. (15 vs. 17) FWD Run Command (or REV) and FWD/REV Run Command (2-wire) (40, 41 vs. 42, 43) External DB Command and Drive Enable (60 vs. 6A) 	<ul style="list-style-type: none"> Check if contradictory settings have simultaneously been assigned to the multi-function input terminals. Correct setting errors.
<p>One of the following settings was entered while H1-□□ = 2 (External Reference 1/2):</p> <ul style="list-style-type: none"> b1-15 = 4 (Pulse Train Input) but the pulse train input selection is not set for the frequency reference (H6-01 > 0) b1-15 or b1-16 set to 3 but no option card is connected Although b1-15 = 1 (Analog Input) and H3-02 or H3-10 are set to 0 (Frequency Bias) 	<p>Correct the settings for the multi-function input terminal parameters.</p>
<p>H2-□□ is set to 38 (Drive Enabled) and H1-□□ is not set to 6A (Drive Enable).</p>	

HOA Keypad Display	Error Name
oPE04	Initialization Required, Term <=> Ctrl Chg
Cause	Possible Solutions
The drive, control board, or terminal board have been replaced and the parameter settings between the control board and the terminal board no longer match.	Set A1-03 to 5550 to load the parameter settings stored in the terminal board to the drive. Initialize parameters after drive replacement by setting A1-03 to 1110 or 2220.

HOA Keypad Display	Error Name
oPE05	Run Command/Frequency Reference Source Selection Error
Cause	Possible Solutions
Frequency reference is assigned to an option card (b1-01 = 3) and an input option card is not connected to the drive.	Reconnect the input option card to the drive.
The Run command is assigned to an option card (b1-02 = 3) and an input option card is not connected to the drive.	
Frequency reference is assigned to the pulse train input (b1-01 = 4) and terminal RP is not set for frequency reference input (H6-01 > 0)	Set H6-01 to 0.

HOA Keypad Display	Error Name
oPE07	Multi-Function Analog Input Selection Error
Cause	Possible Solutions
At least two analog input terminals are set to the same function (i.e., at least two of these parameters have the same setting: H3-02, H3-10, or H3-06).	Change the settings to H3-02, H3-10, and H3-06 so that functions no longer conflict. Note: Both 0 (Frequency Reference Bias) and F (Not Used) can be set to H3-02, H3-10, or H3-06 simultaneously.
The following simultaneous contradictory settings:	Disable one of the PID selections.
<ul style="list-style-type: none"> H3-02, H3-10, or H3-06 = B (PID Feedback) while H6-01 (Pulse Train Input) = 1 (PID Feedback) H3-02, H3-10, or H3-06 = C (PID Target Value) while H6-01 = 2 (pulse train input sets the PID target value) 	

5.5 Operator Programming Errors

HOA Keypad Display	Error Name
oPE08	Parameter Range Setting Error
	Use U1-18 to find parameters set outside the range.
Cause	Possible Solutions
Parameters were set outside the possible setting range.	Set parameters to the proper values.

HOA Keypad Display	Error Name
oPE09	PID Control Selection Fault
	PID control function selection is incorrect. Requires that PID control is enabled (b5-01 = 1 to 4).
Cause	Possible Solutions
The following simultaneous contradictory settings have occurred: <ul style="list-style-type: none"> b5-15 is not set to 0.0 (PID Sleep Function Operation Level) The stopping method is set to either DC Injection Braking or coast to stop with a timer (b1-03 = 2 or 3). 	<ul style="list-style-type: none"> Set b5-15 to a value other than 0.0. Set the stopping method to coast to stop or ramp to stop (b1-03 = 0 or 1).
b5-01 is set to 1 or 2, enabling PID control, but the lower limit for the frequency reference (d2-02) is not set to 0 while reverse output is enabled (b5-11 = 1).	Correct the parameter settings.
b5-01 is set to 3 or 4, enabling PID control, but the lower limit for the frequency reference (d2-01) is not 0.	Correct the parameter settings.

HOA Keypad Display	Error Name
oPE10	V/f Data Setting Error
	One of the following setting errors has occurred: $E1-09 \leq E1-07 < E1-06 \leq E1-11 \leq E1-04$
Cause	Possible Solutions
V/f pattern setting error.	Correct the settings for E1-04, E1-06, E1-07, E1-09, and E1-11.

HOA Keypad Display	Error Name
oPE11	Carrier Frequency Setting Error
	Correct the setting for the carrier frequency.
Cause	Possible Solutions
The following simultaneous contradictory settings have occurred: $C6-05 > 6$ and $C6-04 > C6-03$ (carrier frequency lower limit is greater than the upper limit). If $C6-05 \leq 6$, the drive operates at C6-03.	Correct the parameter settings.
The upper and lower limits between C6-02 and C6-05 are contradictory.	

HOA Keypad Display	Error Name
oPE18	Online Tuning Parameter Setting Error Parameters controlling online tuning are not set correctly.
Cause	Possible Solutions
One of the following errors occurred while online tuning was enabled in OLV (A1-02 = 2): <ul style="list-style-type: none"> E2-02 was set below 30% of the original default value E2-06 was set below 50% of the original default value E2-03 = 0 	Set E2-02, E2-03, and E2-06 to the correct values.

HOA Keypad Display	Error Name
oPE27	Flow Meter Input
Cause	Possible Solutions
Both analog and pulse input flow meters are programmed at the same time.	Reprogram H6-01, H3-02, H3-06, or H3-10.
Flow meter scaling is set to zero and flow meter is being used as PID feedback	Reprogram P6-01, P1-02, or b5-01

HOA Keypad Display	Error Name
oPE30	Incorrect Input Voltage Adjustment The input voltage offset adjustment has not been performed.
Cause	Possible Solutions
One or both of the following conditions are present: <ul style="list-style-type: none"> o2-04, Drive Model Selection, setting changed. EEPROM failed for the input voltage offset. 	Contact Yaskawa or your nearest sales representative for information on clearing the error.

HOA Keypad Display	Error Name
oPE31	Water Level/Suction Pressure/PI Aux Cause The input voltage offset adjustment has not been performed.
Cause	Possible Solutions
One or both of the following conditions are present: <ul style="list-style-type: none"> More than one of these parameters is set to a nonzero value: Q4-01, Q5-01, or Q6-01. Both Water Level/Suction Pressure (H3-□□=23) and PI Aux FB Level (H3-□□=27) are programmed. 	Confirm parameter settings of Q4-01, Q5-01, Q6-01, H3-02, H3-06 and H3-10.

HOA Keypad Display	Minor Fault Name
oPE34 DeScale Set Err	De-Scale Setting Error
Cause	Possible Solution
The De-scale function is not allowed while Anti-Jam is enabled.	Review settings of parameters P1-01, P7-01, or P8-01.

5.6 Auto-Tuning Fault Detection

When the Auto-Tuning faults shown below are detected, the fault is displayed on the HOA keypad and the motor coasts to a stop. Auto-Tuning faults do not trigger a multi-function terminal set for fault or alarm output.

An End□ error indicates that although Auto-Tuning has successfully completed, there is some discrepancy in the calculations. If an End□ error occurs, check for the cause of the error using the table in this section, and perform Auto-Tuning again or manually set the motor parameters after fixing the problem. Start the application if no problem can be diagnosed despite the existence of the End□ error.

◆ Auto-Tuning Codes, Causes, and Possible Solutions

Table 5.7 Auto-Tuning Codes, Causes, and Possible Solutions

HOA Keypad Display	Error Name
End1	Excessive V/f Setting (detected only during Rotational Auto-Tuning and displayed after Auto-Tuning is complete)
Cause	Possible Solutions
The torque reference exceeded 20% during Auto-Tuning.	<ul style="list-style-type: none"> Prior to Auto-Tuning, verify the information on the motor nameplate. Enter proper values from motor nameplate to parameters T1-02 and T1-04 and repeat Auto-Tuning.
The results from Auto-Tuning the no-load current exceeded 80%.	<ul style="list-style-type: none"> If possible, disconnect the motor from the load and perform Auto-Tuning. If the load cannot be uncoupled, use the current Auto-Tuning results.

HOA Keypad Display	Error Name
End2	Motor Iron-Core Saturation Coefficient (detected only during Rotational Auto-Tuning and displayed after Auto-Tuning is complete)
Cause	Possible Solutions
Motor data entered during Auto-Tuning was incorrect.	<ul style="list-style-type: none"> Make sure the data entered to the T1 parameters match the information written on the motor nameplate. Restart Auto-Tuning and enter the correct information.
Results from Auto-Tuning are outside the parameter setting range, assigning the iron-core saturation coefficients (E2-07 and E2-08) to temporary values.	<ul style="list-style-type: none"> Check and correct faulty motor wiring. Disconnect the motor from machine and perform Rotational Auto-Tuning.

HOA Keypad Display	Error Name
End3	Rated Current Setting Alarm (displayed after Auto-Tuning is complete)
Cause	Possible Solutions
The correct current rating printed on the motor nameplate was not entered into T1-04.	<ul style="list-style-type: none"> Check the setting of parameter T1-04. Check the motor data and repeat Auto-Tuning.

HOA Keypad Display	Error Name
End4	Adjusted Slip Calculation Error
Cause	Possible Solutions
The calculated slip is outside the allowable range.	<ul style="list-style-type: none"> Make sure the data entered for Auto-Tuning is correct. If possible, perform Rotational Auto-Tuning. If not possible, perform Stationary Auto-Tuning 2.

HOA Keypad Display	Error Name
End5	Resistance Tuning Error
Cause	Possible Solutions
The calculated resistance value is outside the allowable range.	<ul style="list-style-type: none"> Double-check the data entered for the Auto-Tuning process. Check the motor and motor cable connection for faults.

HOA Keypad Display	Error Name
End6	Leakage Inductance Alarm
Cause	Possible Solutions
The calculated leakage inductance value is outside the allowable range.	Double-check the data entered for the Auto-Tuning process.

HOA Keypad Display	Error Name
End7	No-Load Current Alarm
Cause	Possible Solutions
The entered no-load current value was outside the allowable range.	Check and correct faulty motor wiring.
Auto-Tuning results were less than 5% of the motor rated current.	Double-check the data entered for the Auto-Tuning process.

HOA Keypad Display	Error Name
Er-01	Motor Data Error
Cause	Possible Solutions
Motor data or data entered during Auto-Tuning was incorrect	<ul style="list-style-type: none"> • Check that the motor data entered to T1 parameters matches motor nameplate input before Auto-Tuning. • Restart Auto-Tuning and enter the correct information.
Motor output power and motor-rated current settings (T1-02 and T1-04) do not match.	<ul style="list-style-type: none"> • Check the drive and motor capacities. • Correct the settings of parameters T1-02 and T1-04.
Motor rated current and detected no-load current are inconsistent.	<ul style="list-style-type: none"> • Check the motor rated current and no-load current. • Correct the settings of parameters T1-04 and E2-03.

HOA Keypad Display	Error Name
Er-02	Minor Fault
Cause	Possible Solutions
An alarm was triggered during Auto-Tuning.	Exit the Auto-Tuning menu, check the alarm code, remove the alarm cause, and repeat Auto-Tuning.

HOA Keypad Display	Error Name
Er-03	STOP Button Input
Cause	Possible Solutions
Auto-Tuning canceled by pressing STOP button.	Auto-Tuning did not complete properly. Restart Auto-Tuning.

HOA Keypad Display	Error Name
Er-04	Line-to-Line Resistance Error
Cause	Possible Solutions
Motor data entered during Auto-Tuning was incorrect.	<ul style="list-style-type: none"> • Make sure the data entered to the T1 parameters match the information written on the motor nameplate. • Restart Auto-Tuning and enter the correct information.
Results from Auto-Tuning are outside the parameter setting range or the tuning process took too long.	Check and correct faulty motor wiring.
Faulty motor cable or cable connection.	

HOA Keypad Display	Error Name
Er-05	No-Load Current Error
Cause	Possible Solutions
Motor data entered during Auto-Tuning was incorrect.	<ul style="list-style-type: none"> • Make sure the data entered to the T1 parameters match the information written on the motor nameplate. • Restart Auto-Tuning and enter the correct information.
Results from Auto-Tuning are outside the parameter setting range or the tuning process took too long.	<ul style="list-style-type: none"> • Check and correct faulty motor wiring. • Perform Rotational Auto-Tuning.
The load was too high during Rotational Auto-tuning.	<ul style="list-style-type: none"> • Disconnect the motor from machine and restart Auto-Tuning. If motor and load cannot be uncoupled make sure the load is lower than 30%. • If a mechanical brake is installed, make sure it is fully lifted during tuning.

5.6 Auto-Tuning Fault Detection

HOA Keypad Display	Error Name
Er-08	Rated Slip Error
Cause	Possible Solutions
Motor data entered during Auto-Tuning was incorrect.	<ul style="list-style-type: none"> Make sure the data entered to the T1 parameters match the information written on the motor nameplate. Restart Auto-Tuning and enter the correct information.
Results from Auto-Tuning are outside the parameter setting range or the tuning process took too long.	<ul style="list-style-type: none"> Check and correct faulty motor wiring. Perform Rotational Auto-Tuning.
The load was too high during rotational Auto-tuning.	<ul style="list-style-type: none"> Disconnect the motor from machine and restart Auto-Tuning. If motor and load cannot be uncoupled make sure the load is lower than 30%. If a mechanical brake is installed, make sure it is fully lifted during tuning.

HOA Keypad Display	Error Name
Er-09	Acceleration Error
Cause	Possible Solutions
The motor did not accelerate for the specified acceleration time.	<ul style="list-style-type: none"> Increase the acceleration time (C1-01). Disconnect the machine from the motor if possible.
Torque limit when motoring is too low (L7-01 and L7-02)	<ul style="list-style-type: none"> Check L7-01 and L7-02 settings. Increase the setting.
The load was too high during Rotational Auto-Tuning.	<ul style="list-style-type: none"> Disconnect the motor from machine and restart Auto-Tuning. If motor and load cannot be uncoupled make sure the load is lower than 30%. If a mechanical brake is installed, make sure it is fully lifted during tuning.

HOA Keypad Display	Error Name
Er-11	Motor Speed Fault
Cause	Possible Solutions
Torque reference is too high.	<ul style="list-style-type: none"> Increase the acceleration time (C1-01). Disconnect the machine from the motor if possible.

HOA Keypad Display	Error Name
Er-12	Current Detection Error
Cause	Possible Solutions
One of the motor phases is missing: (U/T1, V/T2, W/T3).	Check motor wiring and correct any problems.
The current exceeded the current rating of the drive.	<ul style="list-style-type: none"> Check motor wiring for a short between motor lines. Close any magnetic contactors used between motors.
The current is too low.	<ul style="list-style-type: none"> Replace the control board or the entire drive. For instructions on replacing the control board, contact Yaskawa or your nearest sales representative.
Attempted Auto-Tuning without motor connected to the drive.	Connect the motor and restart Auto-Tuning.
Current detection signal error.	Replace the control board or the entire drive. For instructions on replacing the control board, contact Yaskawa or your nearest sales representative.

HOA Keypad Display	Error Name
Er-13	Leakage Inductance Error
Cause	Possible Solutions
Drive was unable to complete tuning for leakage inductance within 300 seconds.	<ul style="list-style-type: none"> Check all wiring and correct any mistakes. Check the motor rated current value written on the motor nameplate and enter the correct value to T1-04.

HOA Keypad Display	Error Name
Er-17	Reverse Prohibited Error
Cause	Possible Solutions
Drive is prohibited from rotating the motor in reverse while attempting to perform Inertia Tuning.	<ul style="list-style-type: none"> Inertia Auto-Tuning cannot be performed if the drive is restricted from rotating in reverse. Assuming it is acceptable for the application to rotate in reverse, set b1-04 to 0 and then perform Inertia Tuning.

5.7 Copy Function Related Displays

◆ Tasks, Errors, and Troubleshooting

The table below lists the messages and errors that may appear when using the Copy function.

When executing the tasks offered by the Copy function, the keypad will indicate the task being performed. When an error occurs, a code appears on the keypad to indicate the error. Note that errors related to the Copy function do not trigger a multi-function output terminal that has been set up to close when a fault or alarm occurs. To clear an error, simply press any key on the keypad and the error display will disappear.

Table 5.8 lists the corrective action that can be taken when an error occurs.

- Note:**
1. The drive should be fully stopped when using the copy function.
 2. The drive will not accept a Run command while the Copy function is being executed.
 3. Parameters can only be saved to a drive when the voltage class, capacity, control mode, and software version match.

Table 5.8 Copy Function Task and Error Displays

Keypad Display	Task
CoPy	Writing Parameter Settings (flashing)
Cause	Possible Solution
Parameters are being written to the drive.	This is not an error.
Keypad Display	Task
CPyE	Error Writing Data
Cause	Possible Solutions
Failed writing parameters	Attempt to write parameters again.
Keypad Display	Task
CSEr	Copy Unit Error
Cause	Possible Solutions
Hardware fault	Replace the HOA keypad or the USB Copy Unit.
Keypad Display	Task
dFPS	Drive Model Mismatch
Cause	Possible Solutions
The drives used in the copy and write process are not the same model.	<ul style="list-style-type: none"> • Verify the model number of the drive from which the parameters were copied and the model of the drive to which those parameters will be written. • Make sure the two drives are the same model and have the same software version.
• The drive from which the parameters were copied is a different model.	
• The drive to be written to is a different model.	
Keypad Display	Task
End	Task Complete
Cause	Possible Solutions
Finished reading, writing, or verifying parameters.	This is not an error.
Keypad Display	Task
iFEr	Communication Error
Cause	Possible Solutions
A communication error occurred between the drive and the HOA keypad or the USB copy unit.	Check the cable connection.
A non-compatible cable is being used to connect the USB Copy Unit and the drive.	Use the cable originally packaged with the USB Copy Unit.

5.7 Copy Function Related Displays

Keypad Display	Task
ndAT	Model, Voltage Class, Capacity Mismatch
Cause	Possible Solutions
The drive from which the parameters were copied and the drive to which the parameters will be written have different electrical specifications, capacities, are set to different control modes, or are different models.	Make sure model numbers and specifications are the same for both drives.
The device being used to write the parameters is blank and does not have any parameters saved on it.	Make sure all connections are correct, and copy the parameter settings onto the USB Copy Unit or the HOA keypad.

Keypad Display	Task
rdEr	Error Reading Data
Cause	Possible Solutions
Failed while attempting to read parameter settings from the drive.	Press and hold the READ key on the USB Copy Unit for at least one second to have the unit read parameters from the drive.

Keypad Display	Task
rEAd	Reading Parameter Settings (flashing)
Cause	Possible Solutions
Displayed while the parameter settings are being read onto the USB Copy Unit.	This is not an error.

Keypad Display	Task
vAEr	Voltage Class, Capacity Mismatch
Cause	Possible Solutions
The drive from which the parameters were copied and the drive on which the Verify mode is being performed have different electrical specifications or are a different capacity.	Make sure electrical specifications and capacities are the same for both drives.

Keypad Display	Task
vFyE	Parameter settings in the drive and those saved to the copy function are not the same
Cause	Possible Solutions
Indicates that parameter settings that have been Read and loaded onto the Copy Unit or HOA keypad are different.	To synchronize parameters, either write the parameters saved on the USB Copy Unit or HOA keypad onto the drive, or Read the parameter settings on the drive onto the USB Copy Unit.

Keypad Display	Task
vrFy	Comparing Parameter Settings (flashing)
Cause	Possible Solutions
The Verify mode has confirmed that parameters settings on the drive and parameters read to the copy device are identical.	This is not an error.

5.8 HOA Keypad Display Messages

Table 5.9 lists messages and errors that may appear during normal pump operation.



These messages do not trigger multi-function output terminals that have been set up to close when a fault or alarm occurs.

Table 5.9 HOA Keypad Display Messages

HOA Keypad Display	Description
Anti Jam Active	Displayed when the drive is performing the anti-jam function.
De-staging in X sec	Displayed during multiplexing when either a drive or contactor de-staging is in progress. X sec indicates the time left before the de-staging takes place.
DigitalOut Delay Active	Displayed when the Digital Output Delay function is active.
Feedback Drop Check	Displayed when the drive is determining whether the feedback will change abruptly when the drive enters Sleep Mode. Drop Level is configured by P2-08, Delta Sleep Feedback Drop Level, and P2-09 Feedback Detection Drop Time.
Flow Rate Limit	Drive output speed is being limited due to the Flow Rate (U1-83).
Freq Reduction Active (P3-07)	Maximum Frequency temporarily reduced due to Staging.
LOCK Parameter Locked	Displayed after an attempt to change a parameter when A1-01 = 3. Unlock the keypad by setting A1-01 = 2.
Lube Pump Exit in Xsec	The drive is delaying the start of the motor and the Lube Pump (H2-□□ = 8B) digital output is energized.
PASS MEMOBUS/Modbus Comm. Test Mode Complete	MEMOBUS/Modbus test has finished normally.
Pre Chg Mode Exit in Xsec	Pre-Charge 1 or 2 active. X indicates time left before pre-charge exits due to timers (P4-03 + P4-07).
Primer Pump Exit in Xsec	The drive is delaying the start of the motor and the Primer Pump (H2-□□ = 8B) digital output is energized.
ScreenMtrStarter Exit in Xsec	The drive is delaying the start of the motor and the Screen Motor Starter (H2-□□ = 8B) digital output is energized.
Setpoint Boost Active (P3-11)	Maximum Frequency temporarily reduced due to Staging.
Sleep Active Min/Max PIAuxLvl	Displayed when the PI Aux Feedback falls below the Q6-04/Q6-24 level for longer than the Q6-05 time forcing the drive to go to a sleep condition.
Sleep Active Min Suction Pres	Displayed when the drive has gone to sleep because the suction level has dropped below the level set in Q5-04 for longer than the time set in Q5-05.
Sleep Active Min Water Level	Displayed when the drive has gone to sleep because the water level has dropped below the level set in Q4-04 for longer than the time set in Q4-05.
Sleep Active Wait for Start	Displayed when the drive is in Sleep Mode or when the drive is waiting for the feedback level to reach the level set in P1-04, Start Level.
Sleep AUTO -> Off AUTO Cmd to RUN	Displayed when parameter P2-15 is set to 1 (Enabled) and drive has turned-off due to Sleep.
Sleep Boost Active	Displayed when the drive entering Sleep Mode and the pressure setpoint is being boosted. During this time, the U1-01, Frequency Reference, monitor will be updated with the boosted setpoint.
Staging in X sec	Displayed during multiplexing when either a drive or contactor staging is in progress. X sec indicates the time left before the staging takes place.
Start Delay Adjust b1-11	Displayed when the drive start is being delayed by Coast to Stop with Timer (Back Spin Timer). This time is adjusted by parameter b1-11, Coast to Stop with Timer Time.
Start Delay Timer Active	Displayed when the feedback level has reached the level set in P1-04, Start Level, and the Start Delay timer is incrementing.
Thrust Mode Thrust Active	Displayed during Thrust Mode.
Utility Delay Adjust by P4-17	Displayed when the drive is delaying the Run command due to the Utility Start Delay Function.

◆ Fault Reset Methods

When a fault occurs, the cause of the fault must be removed and the drive must be restarted. The table below lists the different ways to restart the drive.

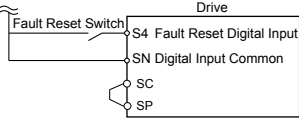
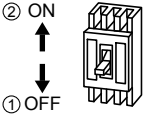
After the Fault Occurs	Procedure	
Fix the cause of the fault, restart the drive, and reset the fault	Press  on the HOA keypad.	
Resetting via a multi-function digital input programmed for Fault Reset (H1-□□ = 14).	For example, close then open the fault signal digital input via terminal S4. S4 is set for “Fault Reset” as default (H1-04 = 14).	
Turn off the main power supply if the above methods do not reset the fault. Reapply power after the HOA keypad display has turned off. When an “SC” error occurs, contact Yaskawa or a Yaskawa agent before cycling the power to the drive.		

Note: If the Run command is present, the drive will disregard any attempts to reset the fault. Remove the Run command before attempting to clear a fault situation.

5.9 Auto-Tuning

◆ Types of Auto-Tuning

The drive offers different types of Auto-Tuning for induction motors. Refer to [Table 5.10](#) to select the type of Auto-Tuning that best suits the application.

■ Auto-Tuning for Induction Motors

This feature automatically sets the V/f pattern and motor parameters E1-□□ and E2-□□ for an induction motor.

Table 5.10 Types of Auto-Tuning for Induction Motors

Type	Setting	Application Conditions and Benefits	Control Mode	
			V/f	OLV
Stationary Auto-Tuning for Line-to-Line Resistance	T1-01 = 2	<ul style="list-style-type: none"> The drive is used in V/f Control and other Auto-Tuning selections are not possible. Perform when entering motor data manually while using motor cables longer than 50 m. Drive and motor capacities differ. Tunes the drive after the cable between the drive and motor has been replaced with a cable over 50 m long. Assumes Auto-Tuning has already been performed. Should not be used for any vector control modes unless the motor cable has changed. 	YES	YES
Rotational Auto-Tuning for V/f Control	T1-01 = 3	<ul style="list-style-type: none"> Recommended for applications using Speed Estimation Speed Search or using the Energy Saving function in V/f Control. Assumes motor can rotate while Auto-Tuning is executed. Increases accuracy for certain functions like torque compensation, slip compensation, Energy Saving, and Speed Search. 	YES	–
Stationary Auto-Tuning 2	T1-01 = 4	<ul style="list-style-type: none"> Motor and load cannot be decoupled and the load is higher than 30%. A motor test report is available. After entering the no-load current and the rated slip, the drive calculates and sets all other motor-related parameters. 	–	YES

[Table 5.11](#) lists the data that must be entered for Auto-Tuning. Make sure this data is available before starting Auto-Tuning. The necessary information is usually listed on the motor nameplate or in the motor test report provided by the motor manufacturer.

Table 5.11 Auto-Tuning Input Data

Input Value	Input Parameter	Unit	Tuning Type (T1-01)		
			2 Line-to-Line Resistance	3 Rotational for V/f Control	4 Stationary 2
Control Mode	A1-02	–	0, 2	0	2
Motor rated power	T1-02	kW	YES	YES	YES
Motor rated voltage	T1-03	Vac	–	YES	YES
Motor rated current	T1-04	A	YES	YES	YES
Motor rated frequency	T1-05	Hz	–	YES	YES
Number of motor poles	T1-06	-	–	YES	YES
Motor rated speed	T1-07	r/min	–	YES	YES
Motor no-load current	T1-09	A	–	–	YES
Motor rated slip	T1-10	Hz	–	–	YES
Motor iron loss	T1-11	W	–	YES	–

◆ Auto-Tuning Interruption and Fault Codes

If tuning results are abnormal or the OFF key is pressed before completion, Auto-Tuning will be interrupted and a fault code will appear on the HOA keypad.

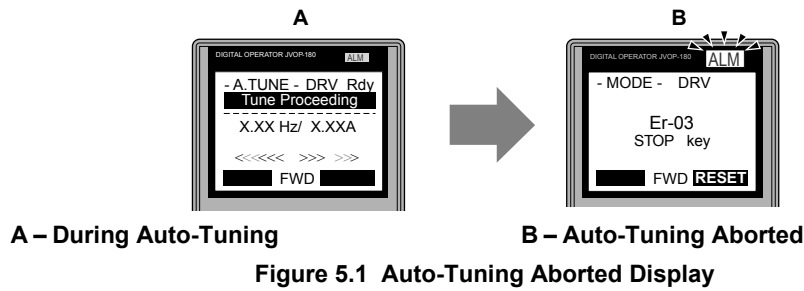

◆ Auto-Tuning Operation Example









The following example demonstrates Stationary Auto-Tuning for Line-to-Line Resistance.

■ Selecting the Type of Auto-Tuning

Step		Display/Result
1.	Turn on the power to the drive. The initial display appears.	<div style="border: 1px solid black; padding: 5px; width: fit-content;"> - MODE - DRV Rdy Auto Setpoint U5-99= 0.0PSI ----- U1-02= 0.00Hz LSEQ U1-91= 0.0PSI LREF <-MONITOR-> </div>
2.	Press or until the Auto-Tuning display appears.	<div style="border: 1px solid black; padding: 5px; width: fit-content;"> - MODE - PRG Auto-Tuning AUTO HELP FWD DATA </div>
3.	Press to begin setting parameters.	<div style="border: 1px solid black; padding: 5px; width: fit-content;"> - A.TUNE - PRG Rdy Tuning Mode Sel ----- T1-01= 2 *2* Term Resistance ESC FWD DATA </div>
4.	Press to display the value for T1-01.	<div style="border: 1px solid black; padding: 5px; width: fit-content;"> - A.TUNE - PRG Rdy Tuning Mode Sel ----- T1-01= 2 *2* Term Resistance "2" ← FWD → </div>
5.	Save the setting by pressing .	<div style="border: 1px solid black; padding: 5px; width: fit-content; text-align: center;"> Entry Accepted </div>
6.	The display automatically returns to the display shown in Step 3.	<div style="border: 1px solid black; padding: 5px; width: fit-content;"> - A.TUNE - PRG Rdy Tuning Mode Sel ----- T1-01= 2 *2* Term Resistance ESC FWD DATA </div>

■ Selecting the Type of Auto-Tuning





















Step		Display/Result
1.	Turn on the power to the drive. The initial display appears.	<div style="border: 1px solid black; padding: 5px; width: fit-content;"> - MODE - DRV Rdy FREF (OPR) U1-01= 0.00Hz ----- U1-02= 0.00Hz LSEQ U1-03= 0.00A LREF JOG FWD FWD/REV </div>
2.	Press or until the Auto-Tuning display appears.	<div style="border: 1px solid black; padding: 5px; width: fit-content;"> - MODE - PRG Auto-Tuning AUTO HELP FWD DATA </div>

Step			Display/Result
3.	Press  to begin setting parameters.	→	- A.TUNE - PRG Rdy Tuning Mode Sel ----- T1-01= 2 *2* Term Resistance  FWD 
4.	Press  to display the value for T1-01.	→	- A.TUNE - PRG Rdy Tuning Mode Sel ----- T1-01= 2 *2* Term Resistance "2"  FWD 
5.	Save the setting by pressing  .	→	Entry Accepted
6.	The display automatically returns to the display shown in Step 3.	→	- A.TUNE - PRG Rdy Tuning Mode Sel ----- T1-01= 2 *2* Term Resistance  FWD 

■ Enter Data from the Motor Nameplate

After selecting the type of Auto-Tuning, enter the data required from the motor nameplate.

Note: These instructions continue from Step 6 in “Selecting the Type of Auto-Tuning”.

Step			Display/Result
1.	Press  to access the motor output power parameter T1-02.	→	- A.TUNE - PRG Rdy Mtr Rated Power ----- T1-02= 0.75kW (0.00 ~ 650.00) "0.75kW"  FWD 
2.	Press  to view the default setting.	→	- A.TUNE - PRG Rdy Mtr Rated Power ----- T1-02= 000.75kW (0.00 ~ 650.00) "0.75kW"  FWD 
3.	Press  left,  right,  ,  , and  to enter the motor power nameplate data in kW.	→	- A.TUNE - PRG Rdy Mtr Rated Power ----- T1-02= 000.40kW (0.00 ~ 650.00) "0.75kW"  FWD 
4.	Press  to save the setting.	→	Entry Accepted
5.	The display automatically returns to the display in Step 1.	→	- A.TUNE - PRG Rdy Mtr Rated Power ----- T1-02= 0.40kW (0.00 ~ 650.00) "0.75kW"  FWD 
6.	Repeat Steps 1 through 5 to set the following parameters: <ul style="list-style-type: none"> • T1-03, Motor Rated Voltage (Rotational Auto-Tuning for V/f Control only) • T1-04, Motor Rated Current • T1-05, Motor Base Frequency • T1-06, Number of Motor Poles • T1-07, Motor Base Frequency (Rotational Auto-Tuning for V/f Control only) • T1-09, Motor No-Load Current (Stationary Auto-Tuning 2 only) • T1-10, Motor Rated Slip (Stationary Auto-Tuning 2 only) 	→	- A.TUNE - PRG Rated Voltage ----- T1-03= 200.0VAC (0.0 ~ 255.0) "200.0VAC"  FWD  ↓ - A.TUNE - PRG Rated Current ----- T1-04= X.XX A (0.35 ~ 7.00) "X.XX A"  FWD 

Note: To execute Stationary Auto-Tuning for line-to-line resistance only, set parameters T1-02 and T1-04.

5.9 Auto-Tuning

■ Starting Auto-Tuning



WARNING! Sudden Movement Hazard. The drive and motor may start unexpectedly during Auto-Tuning, which could result in death or serious injury. Ensure the area surrounding the drive motor and load are clear before proceeding with Auto-Tuning.

WARNING! Electrical Shock Hazard. High voltage will be supplied to the motor when Stationary Auto-Tuning is performed even with the motor stopped, which could result in death or serious injury. Do not touch the motor until Auto-Tuning has been completed.

NOTICE: Rotational Auto-Tuning will not function properly if a holding brake is engaged on the load. Failure to comply could result in improper operation of the drive. Ensure the motor can freely spin before beginning Auto-Tuning.

Enter the required information from the motor nameplate. Press  to proceed to the Auto-Tuning start display.

Note: These instructions continue from Step 6 in “Enter Data from the Motor Nameplate”.

Step			Display/Result
1.	After entering the data listed on the motor nameplate, press  to confirm.	→	<pre> -A.TUNE - DRV Rdy Auto-Tuning ----- 0.00 Hz/ 0.00A Tuning Ready ? Press RUN key ESC FWD </pre>
2.	Press  to activate Auto-Tuning. DRV flashes. The drive begins by injecting current into the motor for about 1 min, and then starts to rotate the motor. Note:	→	<pre> -A.TUNE - DRV Rdy Tune Proceeding ----- X.XX Hz/ X.XXA <<<<< >>>>> FWD </pre>
3.	Auto-Tuning finishes in approximately one to two minutes.	→	<pre> -MODE - DRV End Tune Successful FWD RESET </pre>

Periodic Inspection & Maintenance

This chapter describes the periodic inspection and maintenance of the drive to ensure that it receives the proper care to maintain overall performance.

6.1	SECTION SAFETY.....	252
6.2	INSPECTION.....	254
6.3	PERIODIC MAINTENANCE.....	257
6.4	DRIVE COOLING FANS.....	259
6.5	DRIVE REPLACEMENT.....	288

6.1 Section Safety

WARNING

Electrical Shock Hazard

Do not connect or disconnect wiring while the power is on.

Failure to comply could result in death or serious injury.

Before servicing, disconnect all power to the equipment. The capacitor for the control power supply remains charged even after the power supply is turned off. The charge indicator LED will extinguish when the control power supply voltage is below 50 Vdc. To prevent electric shock, wait for at least the time specified on the warning label; after all indicators are OFF, measure for unsafe voltages to confirm the drive is safe prior to servicing.

Do not operate equipment with covers removed.

Failure to comply could result in death or serious injury.

The diagrams in this section may show drives without covers or safety shields to show details. Be sure to reinstall covers or shields before operating the drives and run the drives according to the instructions described in this manual.

Always ground the motor-side grounding terminal.

Improper equipment grounding could result in death or serious injury by contacting the motor case.

Do not remove covers or touch circuit boards while the power is on.

Failure to comply could result in death or serious injury.

Do not allow unqualified personnel to perform work on the drive.

Failure to comply could result in death or serious injury.

Installation, maintenance, inspection, and service must be performed only by authorized personnel familiar installation, adjustment, and maintenance of drives.

Do not perform work on the drive while wearing loose clothing, jewelry or without eye protection.

Failure to comply could result in death or serious injury.

Remove all metal objects such as watches and rings, secure loose clothing, and wear eye protection before beginning work on the drive.

Do not touch any terminals before the capacitors have fully discharged.

Failure to comply could result in death or serious injury.

Before servicing, disconnect all power to the equipment. The capacitor for the control power supply remains charged even after the power supply is turned off. The charge indicator LED will extinguish when the control power supply voltage is below 50 Vdc. To prevent electric shock, wait for at least the time specified on the warning label; after all indicators are OFF, measure the control power supply voltage level to confirm it has reached a safe level.

Fire Hazard

Tighten all terminal screws to the specified tightening torque.

Loose electrical connections could result in death or serious injury by fire due to overheating of electrical connections.

Do not use an improper voltage source.

Failure to comply could result in death or serious injury by fire.

Verify that the rated voltage of the drive matches the voltage of the incoming power supply before applying power.

Do not use improper combustible materials for the drive.

Failure to comply could result in death or serious injury by fire.

Attach the drive to metal or other noncombustible material.

NOTICE**Observe proper electrostatic discharge procedures (ESD) when handling the drive and circuit boards.**

Failure to comply may result in ESD damage to the drive circuitry.

Follow cooling fan replacement instructions. The cooling fan cannot operate properly when it is installed incorrectly and could seriously damage the drive.

Follow the instructions in this manual to replace the cooling fan, making sure that the label is on top before inserting the cooling fan into the drive. To ensure maximum useful product life, replace both cooling fans when performing maintenance.

Never connect or disconnect the motor from the drive while the drive is outputting voltage.

Improper equipment sequencing could result in damage to the drive.

Do not use unshielded cable for control wiring.

Failure to comply may cause electrical interference resulting in poor system performance. Use shielded, twisted-pair wires and ground the shield to the ground terminal of the drive.

Do not allow unqualified personnel to use the product.

Failure to comply could result in damage to the drive.

Maintenance, inspection, and replacement of parts must be performed only by authorized personnel familiar with installation, adjustment and maintenance of AC drives.

Do not modify the drive circuitry.

Failure to comply could result in damage to the drive and will void warranty.

Yaskawa is not responsible for any modification of the product made by the user. This product must not be modified.

Check all the wiring to ensure that all connections are correct after installing the drive and connecting any other devices.

Failure to comply could result in damage to the drive.

Comply with proper wiring practices.

The motor may run in reverse if the phase order is backward.

Connect motor input terminals U, V and W to drive output terminals U/T1, V/T2, and W/T3. The phase order for the drive and motor should match.

Frequently switching the drive power supply to stop and start the motor can damage the drive.

To get the full performance life out of the capacitor for the control power supply and circuit relays, refrain from switching the drive power supply off and on more than once every 30 minutes. Frequent use can damage the drive. Use the drive to stop and start the motor.

Do not operate damaged equipment.

Failure to comply could result in further damage to the equipment.

Do not connect or operate any equipment with visible damage or missing parts.

6.2 Inspection

Power electronics have limited life and may exhibit changes in characteristics or performance deterioration after years of use under normal conditions. To help avoid such problems, it is important to perform preventive maintenance and periodic inspection on the drive.

Drives contain a variety of power electronics such as power transistors, semiconductors, capacitors, resistors, fans, and relays. The electronics in the drive serve a critical role in maintaining proper motor control.

Follow the inspection lists provided in this chapter as a part of a regular maintenance program.

Note: The drive will require more frequent inspection if it is placed in harsh environments, such as:

- High ambient temperatures
- Frequent starting and stopping
- Fluctuations in the AC supply or load
- Excessive vibrations or shock loading
- Dust, metal dust, salt, sulfuric acid, chlorine atmospheres
- Poor storage conditions.

Perform the first equipment inspection one to two years after installation.

◆ Recommended Daily Inspection

Table 6.1 outlines the recommended daily inspection for Yaskawa drives. Check the following items on a daily basis to avoid premature deterioration in performance or product failure. Copy this checklist and mark the “Checked” column after each inspection.

Table 6.1 General Recommended Daily Inspection Checklist

Inspection Category	Inspection Points	Corrective Action	Checked
Motor	Inspect for abnormal oscillation or noise coming from the motor.	<ul style="list-style-type: none"> • Check the load coupling. • Measure motor vibration. • Tighten all loose components. 	
Cooling	Inspect for abnormal heat generated from the drive or motor and visible discoloration.	Check for the following: <ul style="list-style-type: none"> • Excessive load. • Loose connections. • Dirty heatsink or motor. • Ambient temperature. 	
	Inspect drive cooling fan and circulation fan operation.	Check for the following: <ul style="list-style-type: none"> • Clogged or dirty fan. • Correct Fan operation parameter setting. 	
Environment	Verify the drive environment complies with the specifications listed in <i>Installation Environment</i> on page 44.	Eliminate the source of contaminants or correct poor environment.	
Load	The drive output current should not be higher than the motor or drive rating for an extended period of time.	Check for the following: <ul style="list-style-type: none"> • Excessive load. • Correct motor parameter settings. 	
Power Supply Voltage	Check main power supply and control voltages.	<ul style="list-style-type: none"> • Correct the voltage or power supply to within nameplate specifications. • Verify all main circuit phases. 	

◆ Recommended Periodic Inspection

Table 6.2 outlines the recommended periodic inspections for Yaskawa drive installations. Although periodic inspections should generally be performed once a year; the drive may require more frequent inspection in harsh environments or with rigorous use. Operating and environmental conditions, along with experience in each application, will determine the actual inspection frequency for each installation. Periodic inspection will help to avoid premature deterioration in performance or product failure. Copy this checklist and mark the “Checked” column after each inspection.

■ Periodic Inspection

WARNING! Electrical Shock Hazard. Do not inspect, connect, or disconnect any wiring while the power is on. Failure to comply can result in serious personal injury. Before servicing, disconnect all power to the equipment. The capacitor for the control power supply remains charged even after the power supply is turned off. The charge indicator LED will extinguish when the control power supply voltage is below 50 Vdc. To prevent electric shock, wait for at least the time specified on the warning label; after all indicators are OFF, measure for unsafe voltages to confirm the drive is safe prior to servicing.

Table 6.2 Periodic Inspection Checklist

Inspection Area	Inspection Points	Corrective Action	Checked
Main Circuit Periodic Inspection			
General	<ul style="list-style-type: none"> Inspect equipment for discoloration from overheating or deterioration. Inspect for damaged or deformed parts. 	<ul style="list-style-type: none"> Replace damaged components as required. The drive has few serviceable parts and may require complete drive replacement. 	
	Inspect for dirt, foreign particles, or dust collection on components.	<ul style="list-style-type: none"> Inspect enclosure door seal if used. Remove foreign particles and dust with a vacuum cleaner to avoid touching parts. Replace components if cleaning is not possible. 	
Conductors and Wiring	<ul style="list-style-type: none"> Inspect wiring and connections for discoloration, damage, or heat stress. Inspect wire insulation and shielding for wear. 	Repair or replace damaged wiring.	
Terminals	Inspect terminals for stripped, damaged, or loose connections.	Tighten loose screws and replace damaged screws or terminals.	
Relays and Contactors	<ul style="list-style-type: none"> Inspect contactors and relays for excessive noise during operation. Inspect coils for signs of overheating such as melted or cracked insulation. 	<ul style="list-style-type: none"> Check coil voltage for overvoltage or undervoltage conditions. Replace damaged removable relays, contactors, or circuit board. 	
Electrolytic Capacitor	<ul style="list-style-type: none"> Inspect for leaking, discoloration, or cracks. Check if the cap has come off, for any swelling, or if the sides have burst open. 	The drive has few serviceable parts and may require complete drive replacement.	
Diode, IGBT (Power Transistor)	Inspect for dust or other foreign material collected on the surface.	Remove foreign particles and dust with a vacuum cleaner to avoid touching parts.	
Motor Periodic Inspection			
Operation Check	Check for increased vibration or abnormal noise.	Stop the motor and contact qualified maintenance personnel as required.	
Control Circuit Periodic Inspection			
General	<ul style="list-style-type: none"> Inspect terminals for stripped, damaged, or loose connections. Make sure all terminals have been properly tightened. 	<ul style="list-style-type: none"> Tighten loose screws and replace damaged screws or terminals. If terminals are integral to a circuit board, then board or drive replacement may be required. 	
Circuit Boards	Check for any odor, discoloration, and rust. Make sure connections are properly fastened and that no dust or oil mist has accumulated on the surface of the board.	<ul style="list-style-type: none"> Fix any loose connections. If an antistatic cloth or vacuum plunger cannot be used, replace the board. Do not use any solvents to clean the board. Remove foreign particles and dust with a vacuum cleaner to avoid touching parts. <p>The drive has few serviceable parts and may require complete drive replacement.</p>	
Cooling System Periodic Inspection			
Cooling Fan, Circulation Fan	<ul style="list-style-type: none"> Check for abnormal oscillation or unusual noise. Check for damaged or missing fan blades. 	Replace as required.	
Heatsink	Inspect for dust or other foreign material collected on the surface.	Remove foreign particles and dust with a vacuum cleaner to avoid touching parts.	

6.2 Inspection

Inspection Area	Inspection Points	Corrective Action	Checked
Display Periodic Inspection			
HOA Keypad	<ul style="list-style-type: none">• Make sure data appears on the display properly.• Inspect for dust or other foreign material that may have collected on surrounding components.	<ul style="list-style-type: none">• Contact the nearest sales office if there is any trouble with the display or keypad.• Clean the HOA keypad.	

6.3 Periodic Maintenance

The drive has Maintenance Monitors that keep track of component wear. This feature provides advance maintenance warning and eliminates the need to shut down the entire system for unexpected problems. The drive allows the user to check predicted maintenance periods for the components listed below.

- Cooling Fan, Circulation Fan
- Capacitors for the Control Power Supply
- Inrush Prevention Circuit

For replacement parts, contact the distributor where the drive was purchased or contact Yaskawa or a Yaskawa representative.

◆ Replacement Parts

Table 6.3 contains the estimated performance life of components that require replacement during the life of the drive. Only use Yaskawa replacement parts for the appropriate drive model and revision.

Table 6.3 Estimated Performance Life

Component	Estimated Performance Life
Cooling Fan, Circulation Fan	10 years
Capacitors for the Control Power Supply	10 years <1>

<1> Capacitors for the control power supply cannot be replaced on some lower capacity models. Complete drive replacement may be required for these models.

NOTICE: *Estimated performance life based on specific usage conditions. These conditions are provided for the purpose of replacing parts to maintain performance. Some parts may require more frequent replacement due to poor environments or rigorous use.*

Usage conditions for estimated performance life:

Ambient temperature: Yearly average of 40 °C (IP00/Open Type enclosure)

Load factor: 80% maximum

Operation time: 24 hours a day

■ Performance Life Monitors Maintenance Monitors

The drive calculates the maintenance period for components that may require replacement during the life of the drive. A percentage of the maintenance period is displayed on the HOA keypad by viewing the appropriate monitor parameter.

When the maintenance period reaches 100%, there is increased risk that the drive may malfunction. Yaskawa recommends checking the maintenance period regularly to ensure maximum performance life.

Refer to Recommended Periodic Inspection on page 255 for more details.

Table 6.4 Performance Life Monitors Used for Component Replacement

Parameter	Component	Contents
U4-03	Cooling Fan	Displays the accumulated operation time of the fan from 0 to 99999 hours. This value is automatically reset to 0 after it reaches 99999.
U4-04	Circulation Fan	
U4-05	DC Bus Capacitors	Displays the accumulated time the capacitors are used as a percentage of the specified maintenance period.
U4-06	Pre-Charge Circuit	Displays the number of times the drive is powered up as a percentage of the performance life of the inrush circuit.

6.3 Periodic Maintenance

■ Alarm Outputs for Maintenance Monitors

An output can be set up to inform the user when a specific components has neared its expected performance life.

When one of multi-function digital output terminals has been assigned the maintenance monitor function (H2-□□ = 2F), the terminal will close when the cooling fan, DC bus capacitors, or DC bus pre-charge relay reach 90% of expected performance life. Additionally the HOA keypad will display an alarm like shown in [Table 6.5](#) to indicate the specific components that may need maintenance.

Table 6.5 Maintenance Alarms

Display	Function	Corrective Action
LT-1 </>	The cooling fans have reached 90% of their designated life time.	Replace the cooling fan.
LT-2 </>	The DC bus capacitors have reached 90% of their designated life time.	Contact a Yaskawa representative or the nearest Yaskawa sales office on possible drive replacement.
LT-3 </>	The pre-charge circuit has reached 90% of its designated life time.	Contact a Yaskawa representative or the nearest Yaskawa sales office on possible drive replacement.

<1> This alarm message will be output only if the Maintenance Monitor function is assigned to one of the digital outputs (H2-□□ = 2F). The alarm will also trigger a digital output that is programmed for alarm indication (H2-□□ = 10).

■ Related Drive Parameters

Use parameters o4-03, o4-05, and o4-07, to reset a Maintenance Monitor to zero after replacing a specific component. [Refer to Parameter List on page 319](#) for details on parameter settings.

NOTICE: *If these parameters are not reset after the corresponding parts have been replaced, the Maintenance Monitor function will continue to count down the performance life from the value that was reached with the old part. If the Maintenance Monitor is not reset, the drive will not have the correct value of the performance life for the new component.*

6.4 Drive Cooling Fans

NOTICE: Follow cooling fan replacement instructions. The cooling fan cannot operate properly when installed incorrectly and could seriously damage the drive. To ensure maximum useful product life, replace all cooling fans when performing maintenance.

Contact Yaskawa or a Yaskawa representative to order replacement cooling fans as required.

For drives with multiple cooling fans, replace all the fans when performing maintenance to ensure maximum product performance life.

◆ Number of Cooling Fans

■ Drive Models 2□0028 to 2□0248 and 4□0011 to 4□0930

Drive Model	Cooling Fans	Circulation Fans	Control Board Cooling Fans	Page	
Three-Phase 200 V Class					
2□0028	2	–	–	263	
2□0042	2	–	–		
2□0054	2	–	–		
2□0068	2	–	–		
2□0081	2	–	–		
2□0104	2	–	–		
2□0130	2	–	–		
2□0154	3	–	–	265	
2□0192	3	–	–	269	
2□0248	1	2	–		
Three-Phase 400 V Class					
4□0011	2	–	–	263	
4□0014	2	–	–		
4□0021	2	–	–		
4□0027	2	–	–		
4□0034	2	–	–		
4□0040	2	–	–		
4□0052	2	–	–		
4□0065	2	–	–		
4□0077	2	–	–		
4□0096	2	–	–		
4□0124	2	–	–		
4□0156	3	–	–		265
4□0180	3	–	–		269
4□0216	1	2	–		
4□0240	1	2	–		
4□0302	2	2	–		
4□0361	2	2	–		
4□0414	2	2	–	274	
4□0477	4	4	2		
4□0590	4	4	2		
4□0720	4	4	2	278	
4□0930	4	4	2		

6.4 Drive Cooling Fans

■ Harmonic Filter Modules

Model	Cooling Fans	Circulation Fans	Control Board Cooling Fans	Page
EUJ71180□.□	4	1	1	283
EUJ71182□.□	4	1	1	

◆ Cooling Fan Component Names

WARNING! Electrical Shock Hazard. Do not connect or disconnect wiring while the power is on. Failure to comply can result in serious personal injury. Before servicing the drive, disconnect all power to the equipment. The capacitor for the control power supply remains charged even after the power supply is turned off. After shutting off the power, wait for at least the amount of time specified on the drive before touching any components.

CAUTION! Burn Hazard. Do not touch a hot drive heatsink. Failure to comply could result in minor or moderate injury. Shut off the power to the drive when replacing the cooling fan. To prevent burns, wait at least 15 minutes and ensure the heatsink has cooled down.

NOTICE: Prevent Equipment Damage. Follow cooling fan and circulation fan replacement instructions. Fans cannot operate properly when they are installed incorrectly and can damage the drive. Follow the instructions below to replace the fans, making sure that the label is on top before inserting the fan into the drive. To ensure maximum useful product life, replace all fans when performing maintenance.

Note: Procedures shown in this section use a representative drive model. Figures in these procedures may differ slightly from the actual model used by the customer.

■ Drive Models 2□0028 to 2□0248 and 4□0011 to 4□0930

2□0028 to 2□0130 and 4□0011 to 4□0124

2□0154, 2□0192, 4□0156, and 4□0180

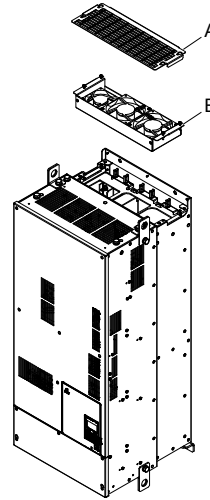
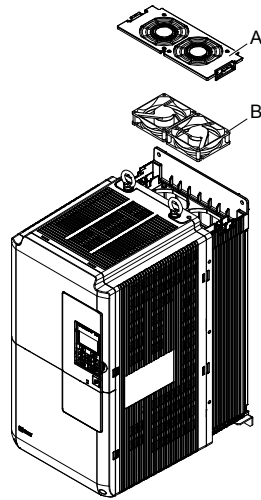

2□0248 and 4□0216 to 4□0414

4□0477 to 4□0930

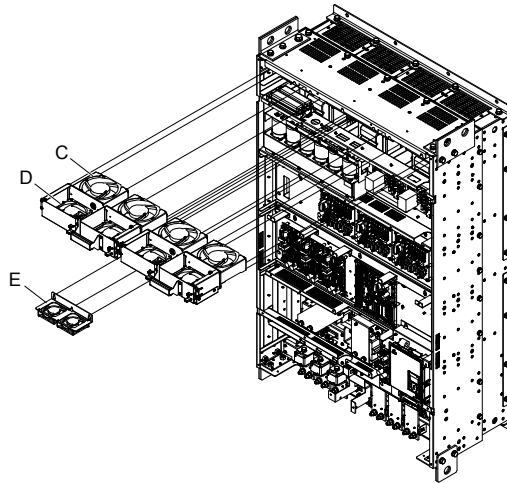
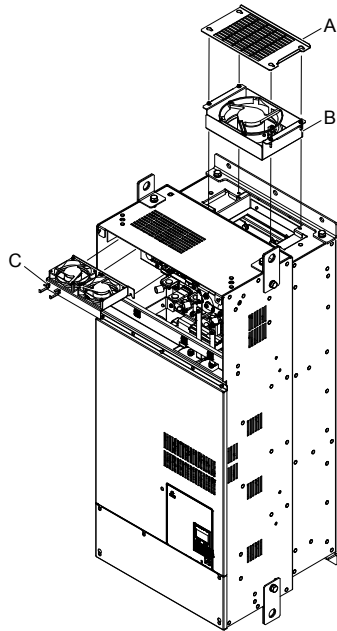

- A – Fan guard
- B – Cooling Fan/Cooling Fan Unit
- C – Cooling Fan/Cooling Fan Unit/
Circulation Fan Unit

- D – Circulation Fan
- E – Control Board Cooling Fan/ Control
Board Cooling Fan Unit

Figure 6.1 Drive Cooling Fan Component Names

■ Harmonic Filter Modules

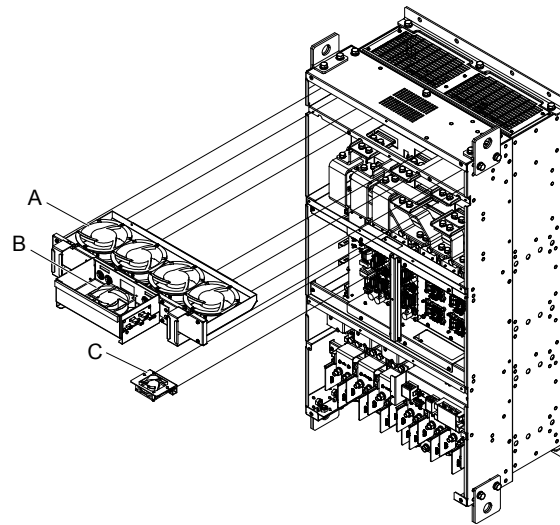

**A – Cooling Fan/Cooling Fan Unit/
Circulation Fan Unit**
B – Circulation Fan

**C – Control Board Cooling Fan/ Control
Board Cooling Fan Unit**

Figure 6.2 Harmonic Filter Module Cooling Fan Component Names

◆ Drive Cooling Fan Replacement: Models 2□0028 to 2□0130 and 4□0011 to 4□0124

WARNING! *Electrical Shock Hazard. Do not connect or disconnect wiring while the power is on. Failure to comply can result in serious personal injury. Before servicing the drive, disconnect all power to the equipment. The capacitor for the control power supply remains charged even after the power supply is turned off. After shutting off the power, wait for at least the amount of time specified on the drive before touching any components.*

CAUTION! *Burn Hazard. Do not touch a hot drive heatsink. Failure to comply could result in minor or moderate injury. Shut off the power to the drive when replacing the cooling fan. To prevent burns, wait at least 15 minutes and ensure the heatsink has cooled down.*

NOTICE: *Damage to Equipment. Follow cooling fan and circulation fan replacement instructions. Improper fan replacement could cause damage to equipment. Make sure the fan is facing upwards when installing the replacement fan into the drive. Replace all fans when performing maintenance to help ensure maximum useful product life.*

■ Removing the Cooling Fan Guard and Cooling Fan

1. Depress the right and left sides of the fan guard tabs and pull upward. Remove the fan guard from the top of the drive.

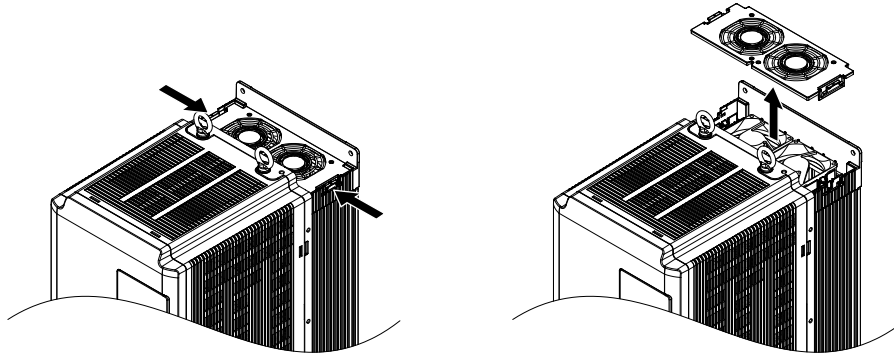

Figure 6.3 Remove the Fan Guard

2. Remove the cooling fan cartridge.

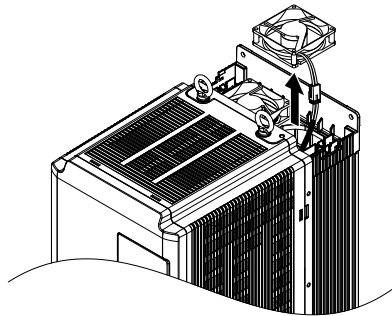

Figure 6.4 Remove the Cooling Fan Cartridge

3. Disconnect the pluggable connector and remove the fan.

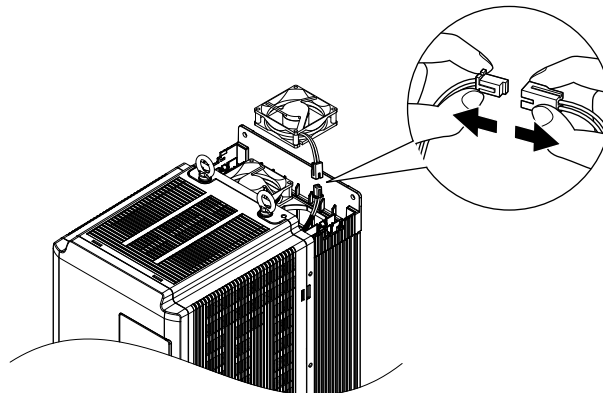

Figure 6.5 Disconnect the Cooling Fan

■ Installing the Cooling Fan

Reverse the procedure described above to reinstall the cooling fan.

1. Properly plug the relay connector.

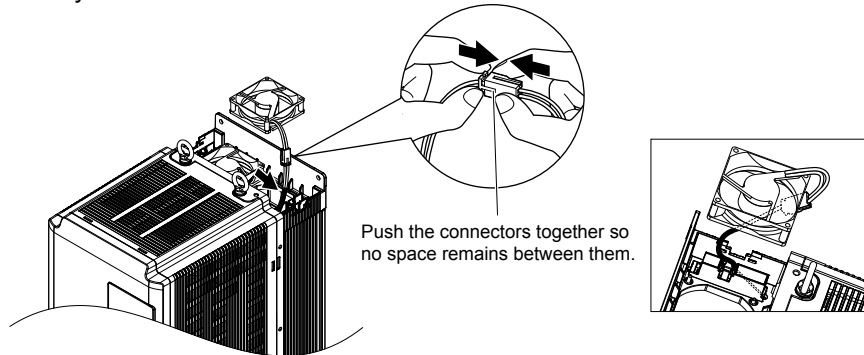
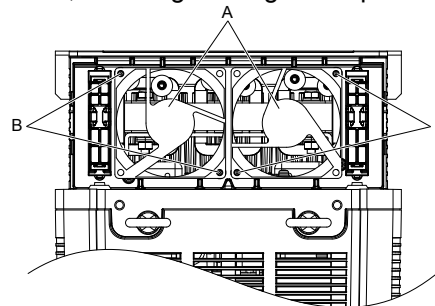

Figure 6.6 Plug the Relay Connector

2. Install the replacement fan into the drive, ensuring the alignment pins line up as shown in [Figure 6.7](#).



A – Label facing up

B – Make sure the alignment pins line up properly.

Figure 6.7 Install the Cooling Fan

3. Properly connect the fan power lines, then place the cable back into the recess of the drive.

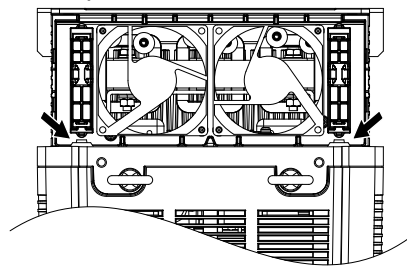

Figure 6.8 Relay Connector Placement

4. While pressing in on the tabs on the left and right sides of the fan guard, guide the fan guard until it clicks back into place.

Note: The fan guard has a cutout on the front side for proper alignment.

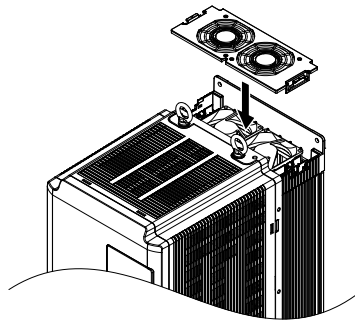

Figure 6.9 Reattach the Fan Guard

5. Turn on the power supply and set o4-03 to 0 to reset the Maintenance Monitor cooling fan operation time.

◆ Drive Cooling Fan Replacement: Models 2□0154, 2□0192, 4□0156, and 4□0180

WARNING! *Electrical Shock Hazard. Do not connect or disconnect wiring while the power is on. Failure to comply can result in serious personal injury. Before servicing the drive, disconnect all power to the equipment. The capacitor for the control power supply remains charged even after the power supply is turned off. After shutting off the power, wait for at least the amount of time specified on the drive before touching any components.*

CAUTION! *Burn Hazard. Do not touch a hot drive heatsink. Failure to comply could result in minor or moderate injury. Shut off the power to the drive when replacing the cooling fan. To prevent burns, wait at least 15 minutes and ensure the heatsink has cooled down.*

NOTICE: *Damage to Equipment. Follow cooling fan and circulation fan replacement instructions. Improper fan replacement could cause damage to equipment. Make sure the fan is facing upwards when installing the replacement fan into the drive. Replace all fans when performing maintenance to help ensure maximum useful product life.*

■ Removing the Fan Guard and Cooling Fan

1. Loosen the 4 screws that hold the fan guard in place.

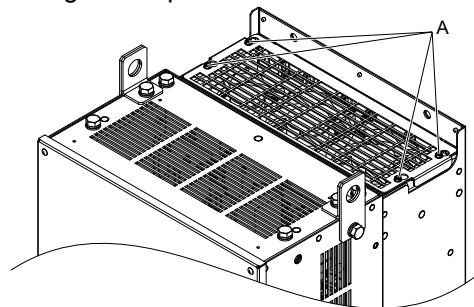

A –Screw locations

Figure 6.10 Loosen the Screws

2. Slide the fan guard toward the front of the drive to remove it from the drive.

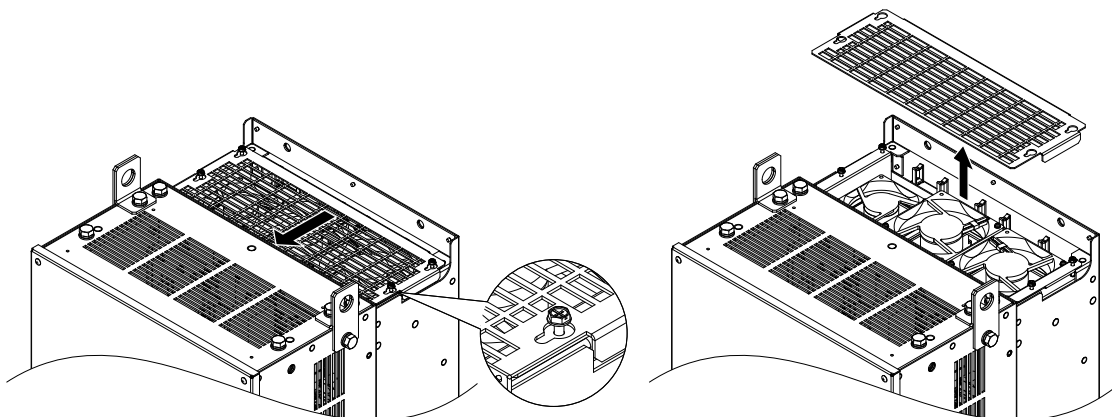
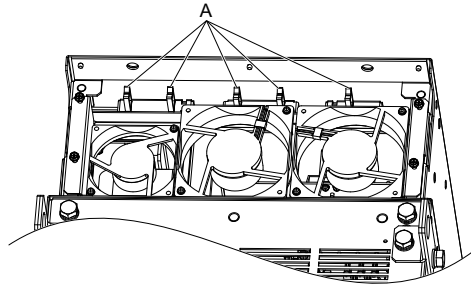

Figure 6.11 Remove the Fan Guard

6.4 Drive Cooling Fans

3. Release the cables from the hooks in 5 locations.



A –Hook locations

Figure 6.12 Release the Cables

4. Loosen the 4 screws affixing the cooling fan unit.

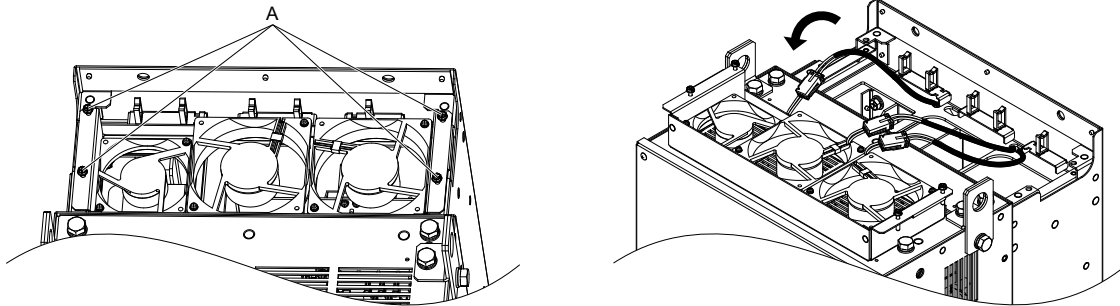

A –Screw locations

Figure 6.13 Remove the Cooling Fan Unit

5. Disconnect the 3 pluggable connectors and remove the fan unit from the drive.

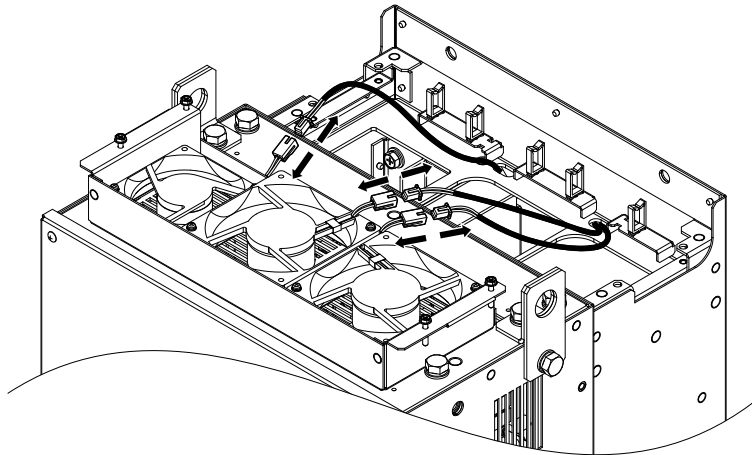

Figure 6.14 Unplug the Relay Connectors

■ Installing the Cooling Fan Unit

1. Connect the relay connectors for the fans in the replacement fan unit.

Note: Replace the whole unit when performing maintenance on the cooling fans.

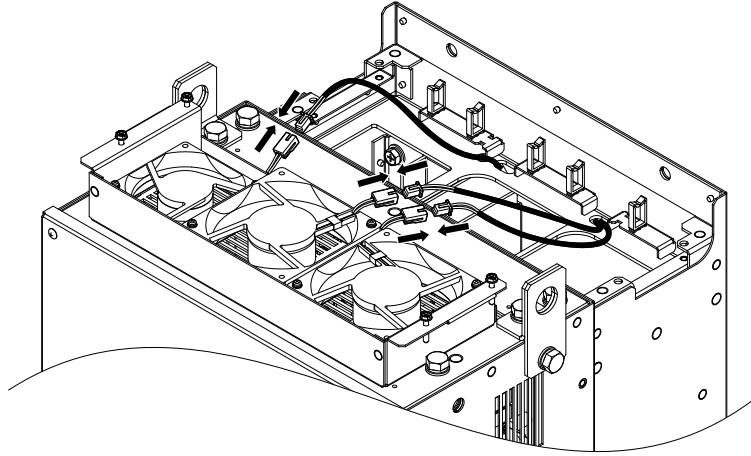

Figure 6.15 Plug the Relay Connectors

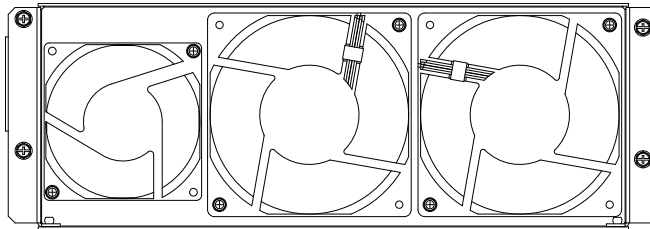
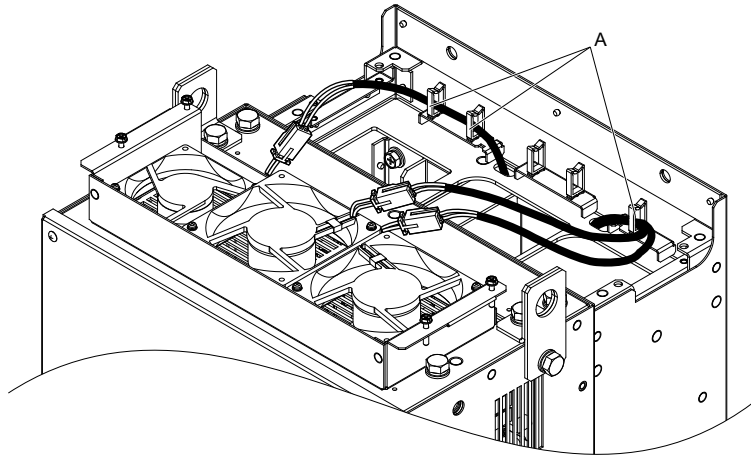

Figure 6.16 Cooling Fan Unit

2. Guide the fan cables through the provided hooks to hold the cables in place.



A –Hook locations

Figure 6.17 Position the Fan Cables

3. Install the cooling fan unit while pulling the cables upward.

Note: Do not pinch the fan cable between parts when reassembling the fan unit.

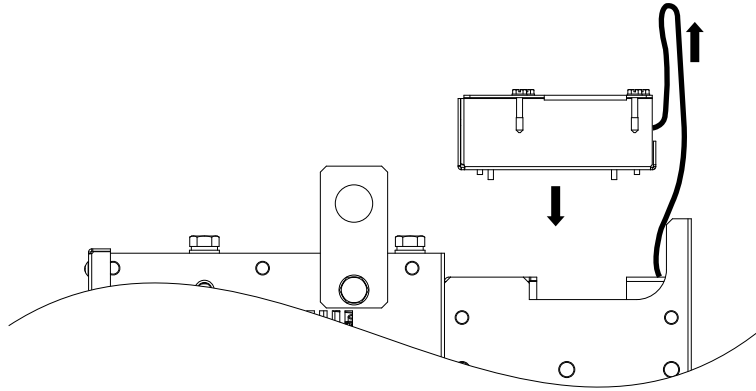
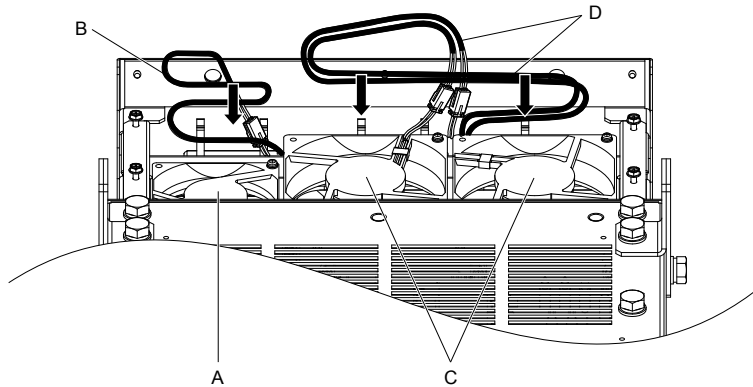

Figure 6.18 Install the Cooling Fan Unit

4. Guide the cables through the second set of provided hooks to hold the cables in place.



A – Cooling fan A
B – Bend 3 times

C – Cooling fan B
D – Bend 2 times

Figure 6.19 Cooling Fan Wire Routing

5. Thread the 4 fan unit screws into the proper holes approximately 2/3 of the way. Leave enough space to reinsert the fan guard.

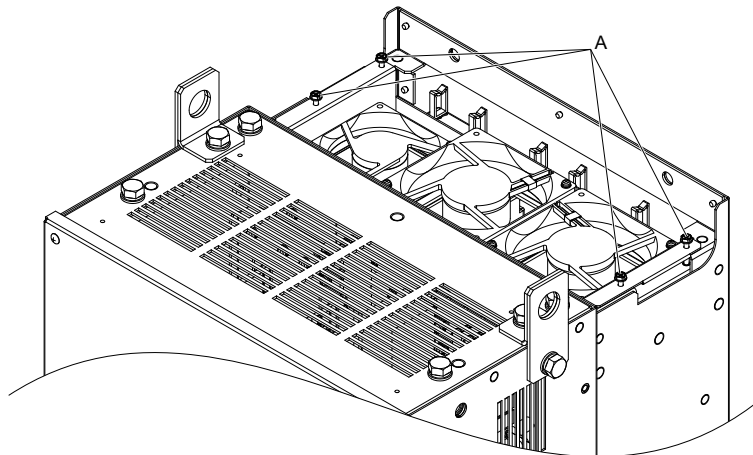

A –Screw locations

Figure 6.20 Insert Cooling Fan Screws

6. Insert the fan guard and firmly tighten the screws so they do not come loose.

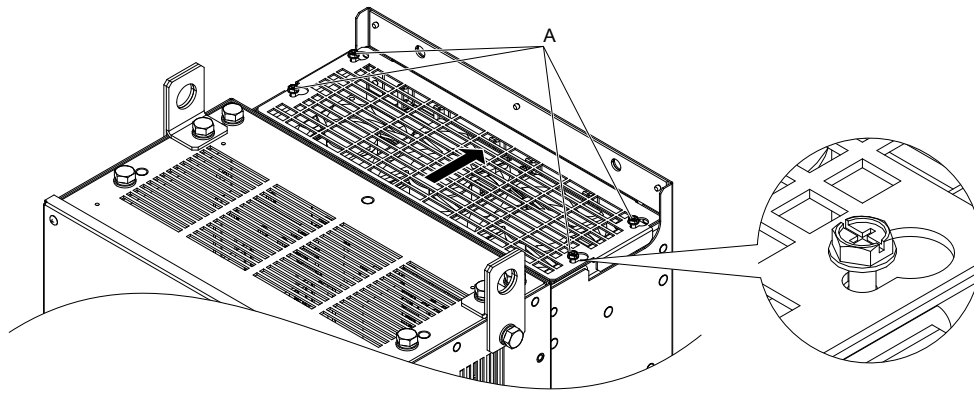

A –Screw locations

Figure 6.21 Reattach the Fan Guard

7. Turn on the power supply and set o4-03 to 0 to reset the Maintenance Monitor cooling fan operation time.

◆ Drive Cooling Fan Replacement: Models 2□0248 and 4□0216 to 4□0414

WARNING! *Electrical Shock Hazard. Do not connect or disconnect wiring while the power is on. Failure to comply can result in serious personal injury. Before servicing the drive, disconnect all power to the equipment. The internal capacitor remains charged even after the power supply is turned off. After shutting off the power, wait for at least the amount of time specified on the drive before touching any components.*

CAUTION! *Burn Hazard. Do not touch a hot drive heatsink. Failure to comply could result in minor or moderate injury. Shut off the power to the drive when replacing the cooling fan. To prevent burns, wait at least 15 minutes and ensure the heatsink has cooled down.*

NOTICE: *Damage to Equipment. Follow cooling fan and circulation fan replacement instructions. Improper fan replacement could cause damage to equipment. Follow the instructions and replace the entire unit when replacing the cooling fan.*

■ Removing the Fan Guard and Cooling Fan

1. Loosen the 4 screws that hold the fan guard in place.

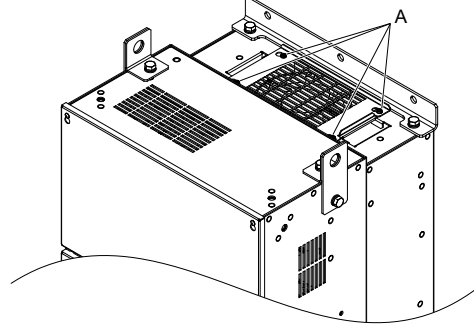

A –Screw locations

Figure 6.22 Loosen the Screws

2. Slide the fan guard toward the right to remove it from the drive.

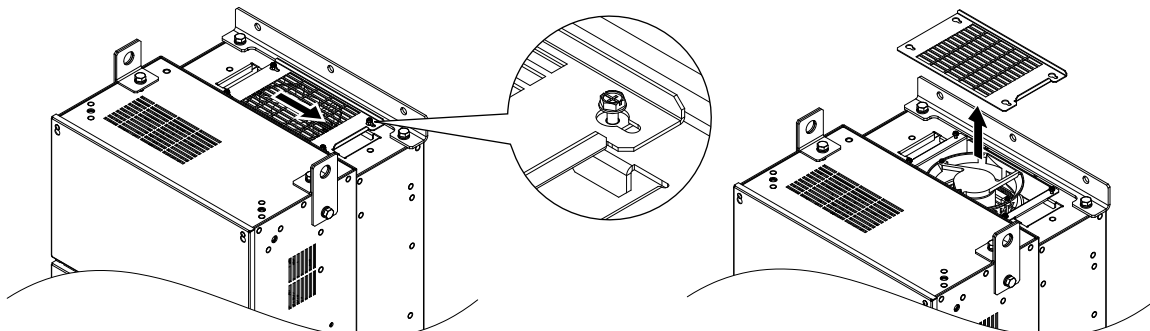
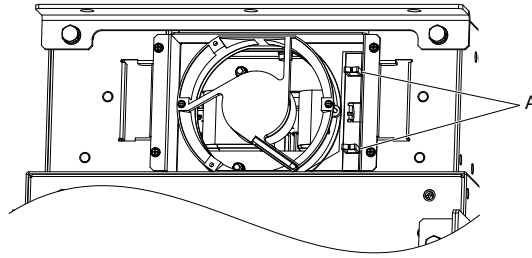

Figure 6.23 Remove the Fan Guard

6.4 Drive Cooling Fans

3. Release the cable from the hooks.

Note: Models 4□0302 to 4□0414 have 4 hooks.



A –Hook locations

Figure 6.24 Release the Cable

4. Loosen the 2 screws affixing the cooling fan unit.

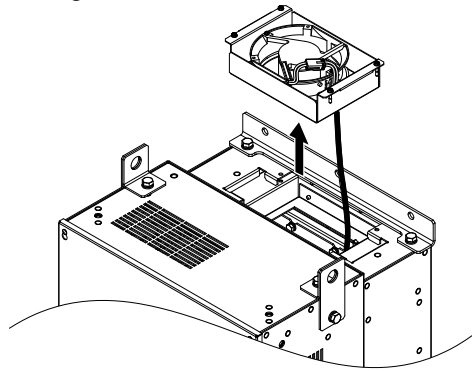

Figure 6.25 Remove the Cooling Fan Unit

5. Unplug the relay connector and release the fan from the drive.

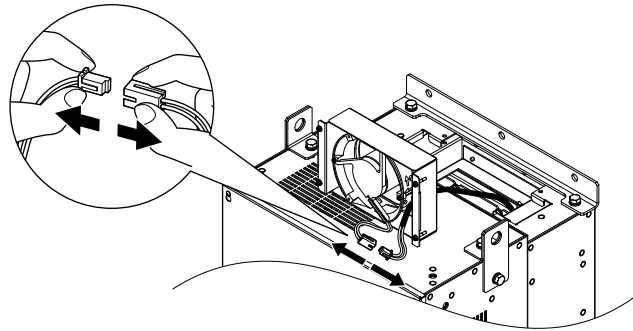
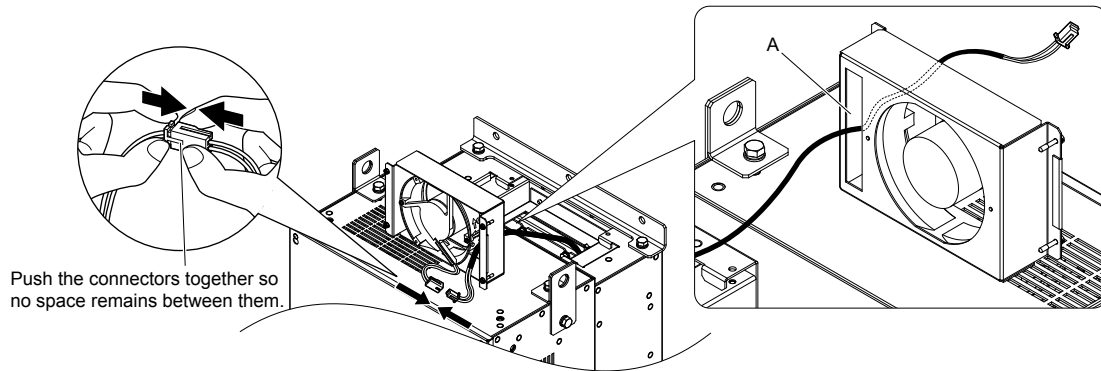

Figure 6.26 Unplug the Relay Connector

◆ Installing the Cooling Fan

1. Pass the cable through the opening of the replacement cooling fan unit from the back side, then plug the relay connector.



A –Opening

Figure 6.27 Attach the Relay Connector

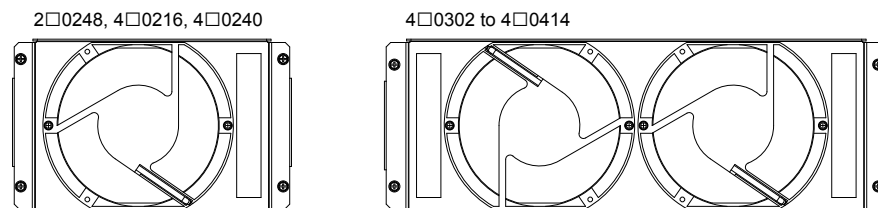
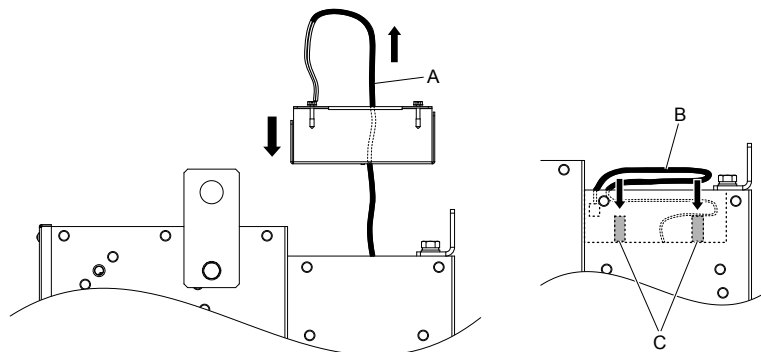

Figure 6.28 Cooling Fan Unit

2. Install the cooling fan unit and place the cable back into position.

- Note:**
1. Replace the whole unit when performing maintenance on the cooling fans.
 2. Install the cooling fan unit while pulling the cable upward so that the cable does not get pinched between parts.



A – Pull the cable upwards
B – Bend 3 times

C – Hook

Figure 6.29 Install the Cooling Fan

3. Thread the 4 fan unit screws into the proper holes approximately 2/3 of the way. Leave enough space to reinsert the fan guard.

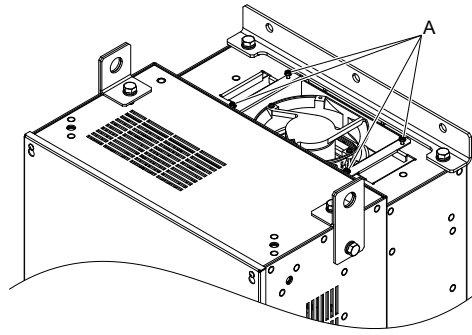

A –Screw locations

Figure 6.30 Attach the Cooling Fan Unit

4. Reattach the fan guard and then tighten the screws firmly so that the screws do not come loose.

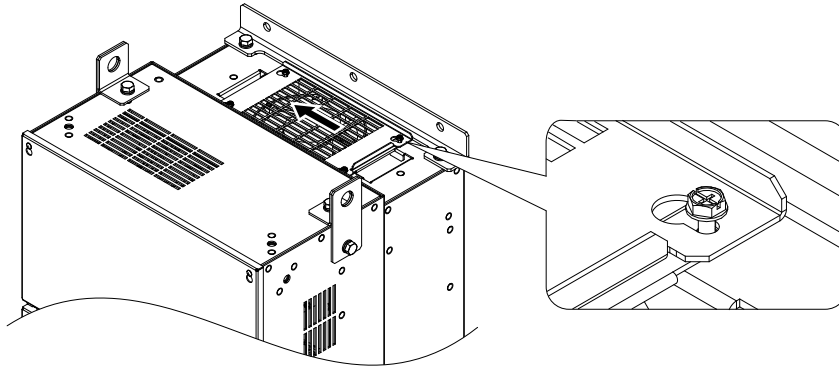
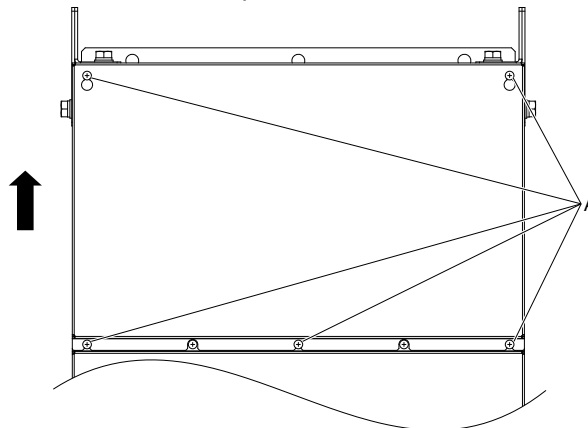

Figure 6.31 Reattach the Fan Cover

■ Removing the Circulation Fan

CAUTION! *Crush Hazard. Do not completely remove the cover screws, just loosen them. If the cover screws are removed completely, the terminal cover may fall off causing an injury. Take special care when removing/reattaching the terminal covers for larger drives.*

1. Loosen the 5 screws that hold the drive cover in place.



A –Screw locations

Figure 6.32 Remove the Drive Cover

2. Unlock the 2 cable hooks.

Note: The circulation fan unit on models 4□0302 to 4□0414 is located on the right side of the drive.

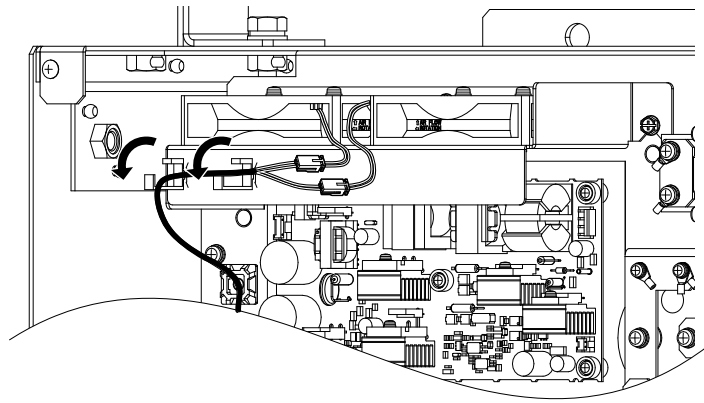

Figure 6.33 Unlock the Cable Hooks

- Unplug the relay connectors and release the cable from the hooks.

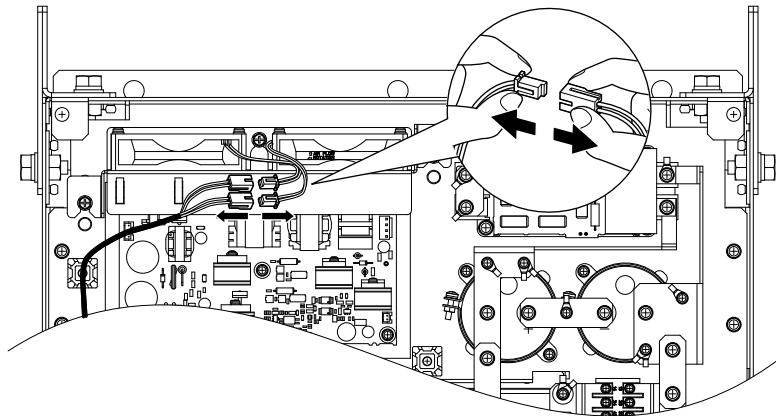
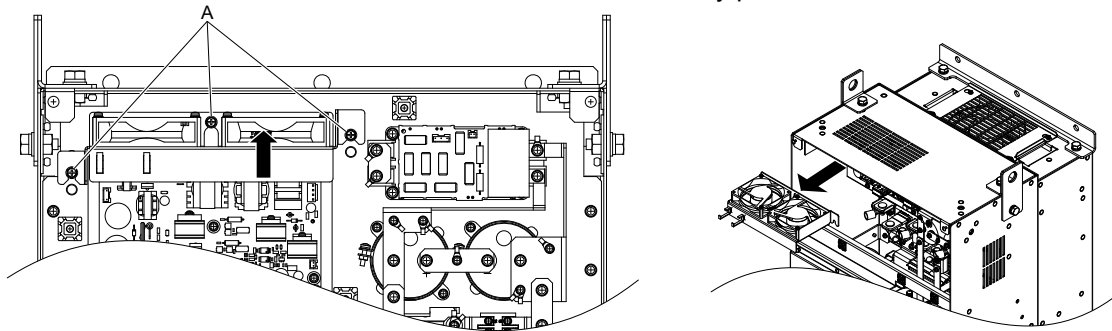

Figure 6.34 Unplug the Relay Connector

- Loosen the 3 screws, then slide the circulation fan unit and carefully pull it out.



A –Screw locations

Figure 6.35 Remove the Circulation Fan

■ Installing the Circulation Fan

CAUTION! *Crush Hazard. Do not completely remove the cover screws, just loosen them. If the cover screws are removed completely, the terminal cover may fall off causing an injury. Take special care when removing/reattaching the terminal covers for larger drives.*

- Reverse the procedure described above to install the replacement circulation fan unit.

- Note:**
- Replace the whole unit when performing maintenance on the circulation fans.
 - Place the cables back into the hooks to secure.
 - Do not pinch the fan cable between parts when reassembling the fan unit.
 - Tighten the screws firmly so they do not come loose.

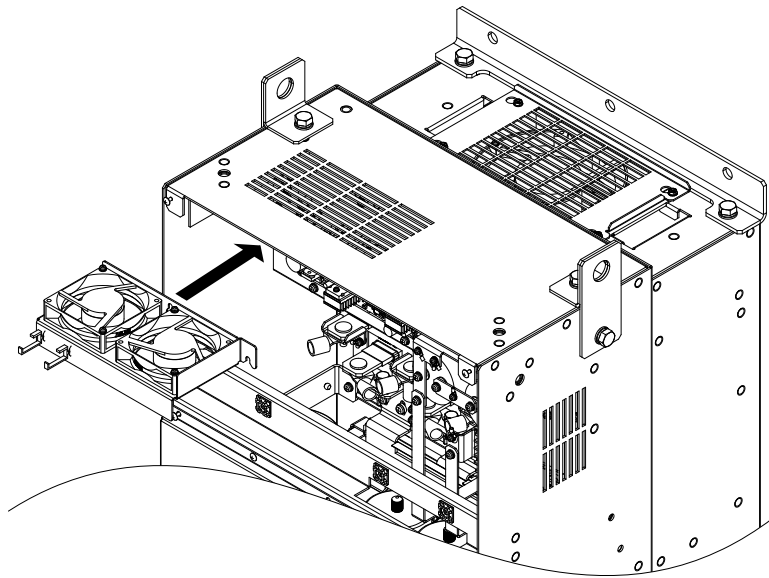

Figure 6.36 Installing the Circulation Fan

2. Turn on the power supply and set o4-03 to 0 to reset the Maintenance Monitor circulation fan operation time.

◆ Drive Cooling Fan Replacement: Models 4□0477 and 4□0590

WARNING! *Electrical Shock Hazard.* Do not connect or disconnect wiring while the power is on. Failure to comply can result in serious personal injury. Before servicing the drive, disconnect all power to the equipment. The internal capacitor remains charged even after the power supply is turned off. After shutting off the power, wait for at least the amount of time specified on the drive before touching any components.

CAUTION! *Burn Hazard.* Do not touch a hot drive heatsink. Failure to comply could result in minor or moderate injury. Shut off the power to the drive when replacing the cooling fan. To prevent burns, wait at least 15 minutes and ensure the heatsink has cooled down.

NOTICE: *Prevent Equipment Damage.* Follow cooling fan and circulation fan replacement instructions. Improper fan replacement could cause damage to equipment. Follow the instructions and replace the entire unit when replacing the cooling fan.

■ Removing the Cooling Fan Unit

CAUTION! *Crush Hazard.* Do not completely remove the cover screws, just loosen them. If the cover screws are removed completely, the terminal cover may fall off causing an injury. Take special care when removing/reattaching the terminal covers for larger drives.

1. Loosen the 9 screws that hold drive cover 1 in place and free it from the drive.

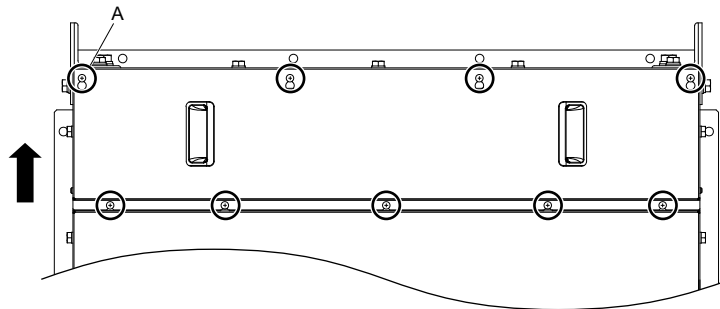

A –9 screw locations

Figure 6.37 Loosen the Screws and Remove Drive Cover 1

2. Loosen the 9 screws that hold the terminal cover in place and free it from the drive.

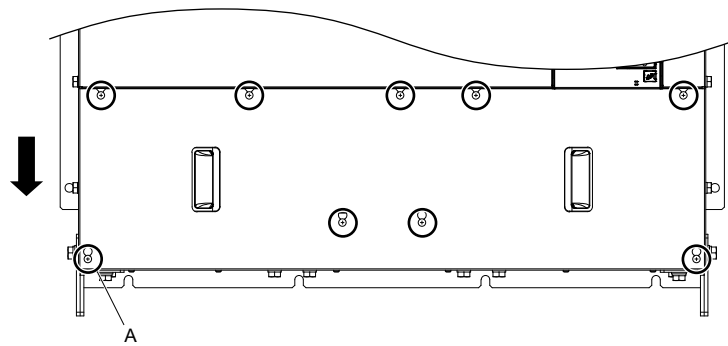

A -9 screw locations

Figure 6.38 Loosen the Screws and Remove the Terminal Cover

- Loosen the 25 screws that hold the drive cover 2 in place and free it from the drive.

CAUTION! Crush Hazard. Do not completely remove the cover screws, just loosen them. If the cover screws are removed completely, the terminal cover may fall off causing an injury. Take special care when removing/reattaching the terminal covers for larger drives.

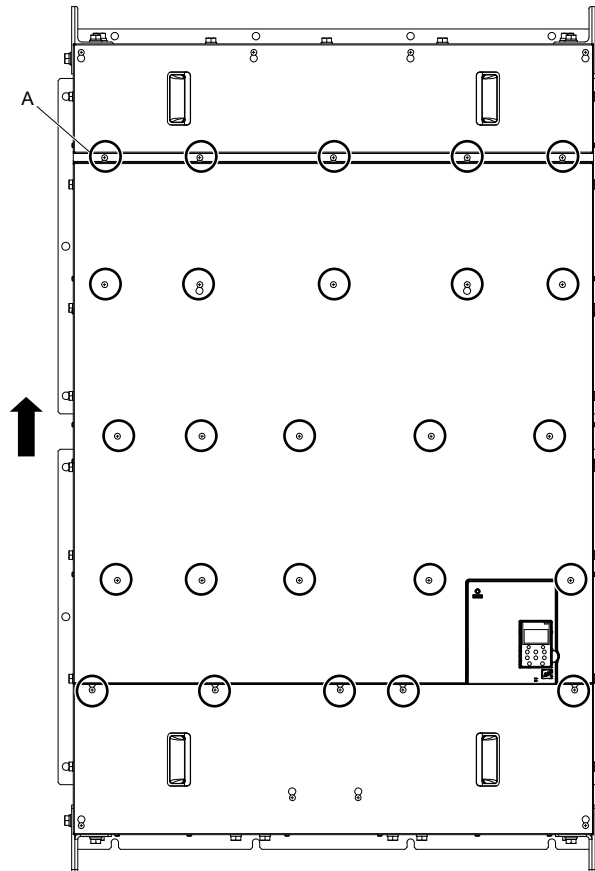

A -25 screw locations

Figure 6.39 Loosen the Screws and Remove Drive Cover 2

- Unplug the relay connectors and free the cable from the cooling fan unit.

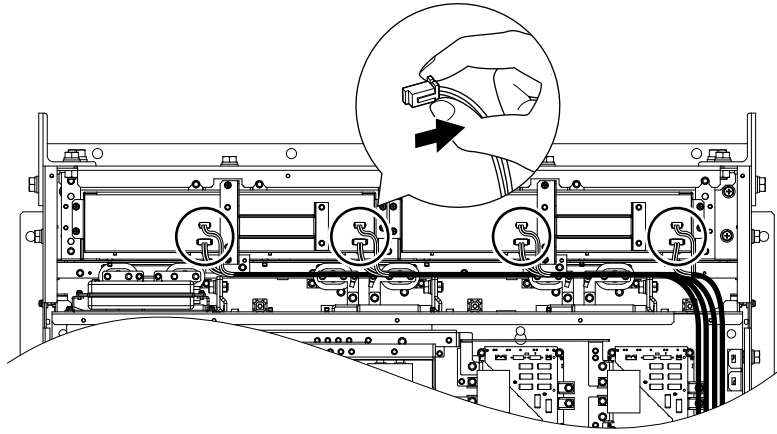
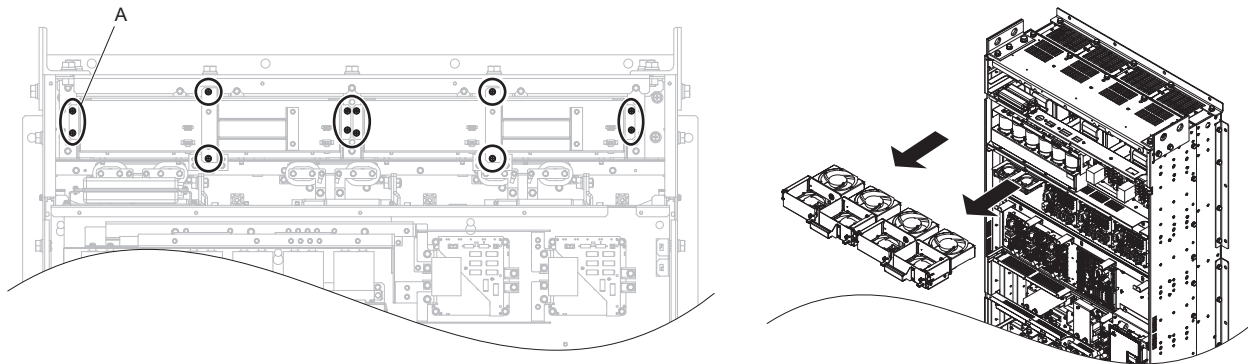

Figure 6.40 Unplug the Relay Connectors

5. Loosen the 12 screws, then slide the cooling fan unit and carefully pull it out.



A -25 screw locations

Figure 6.41 Remove the Cooling Fan Unit

■ Installing the Cooling Fan Unit

CAUTION! *Crush Hazard. Do not completely remove the cover screws, just loosen them. If the cover screws are removed completely, the terminal cover may fall off causing an injury. Take special care when removing/reattaching the terminal covers for larger drives.*

1. Reverse the procedure described above to install the replacement cooling fan unit.

- Note:**
1. Replace the whole unit when performing maintenance on the cooling fan unit.
 2. Do not pinch the fan cable between parts when reassembling the fan unit.
 3. Tighten the screws firmly so they do not come loose.

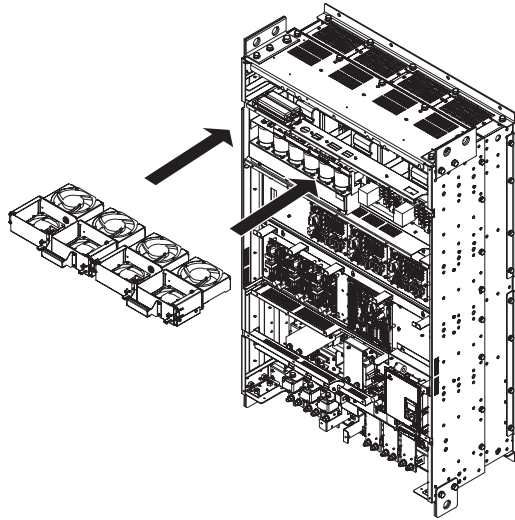

Figure 6.42 Installing the Cooling Fan Unit

2. Turn on the power supply and set o4-03 to 0 to reset the Maintenance Monitor circulation fan operation time.

■ Removing the Control Board Cooling Fan Unit

1. Unplug the relay connectors and free the cable from the control board cooling fan unit.

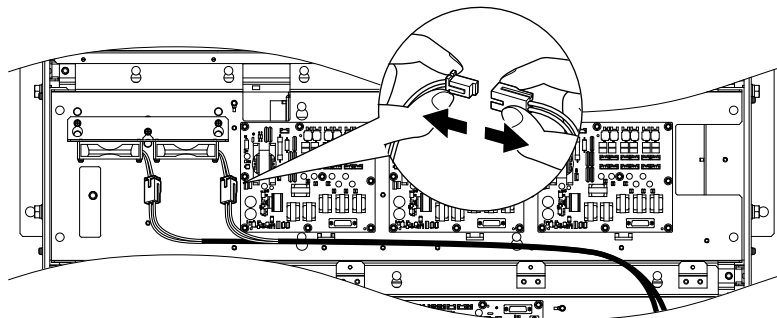
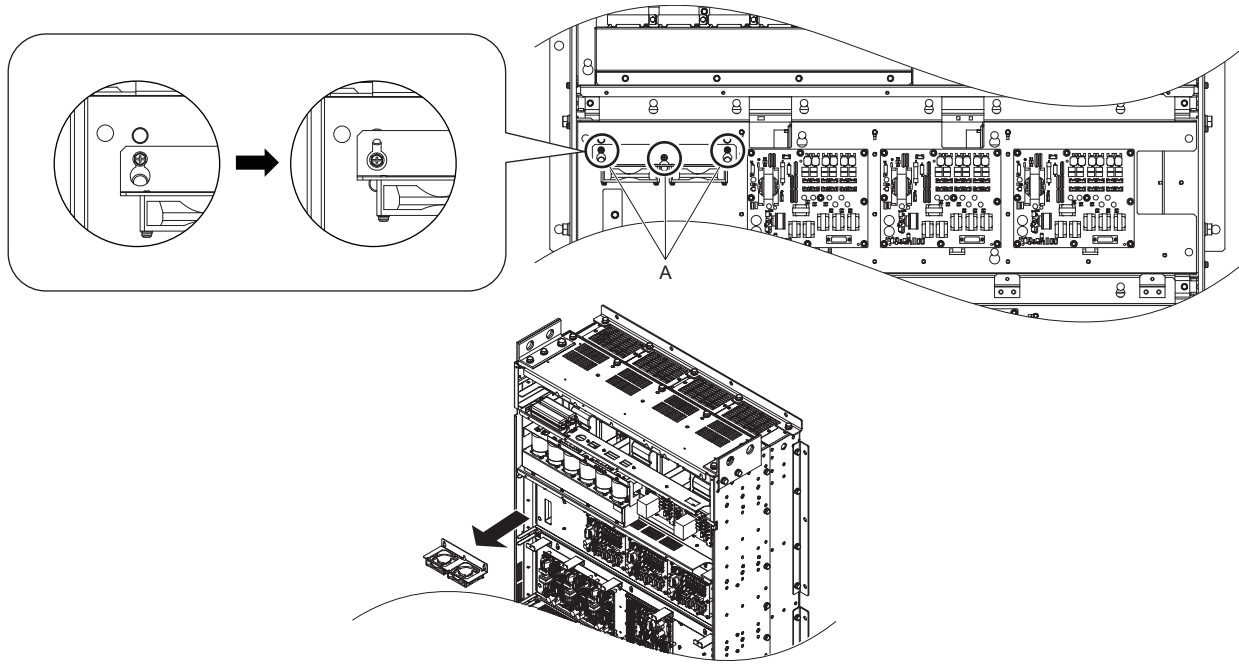

Figure 6.43 Unplug the Relay Connectors

2. Loosen the 3 screws, then slide the control board cooling fan unit and carefully pull it out.



A –3 screw locations

Figure 6.44 Remove the Control Board Cooling Fan Unit

■ Installing the Control Board Cooling Fan Unit

CAUTION! *Crush Hazard. Do not completely remove the cover screws, just loosen them. If the cover screws are removed completely, the terminal cover may fall off causing an injury. Take special care when removing/reattaching the terminal covers for larger drives.*

1. Reverse the procedure described above to install the replacement control board cooling fan unit.

- Note:**
1. Replace the whole unit when performing maintenance on the control board cooling fan unit.
 2. Do not pinch the fan cable between parts when reassembling the fan unit.
 3. Tighten the screws firmly so they do not come loose.

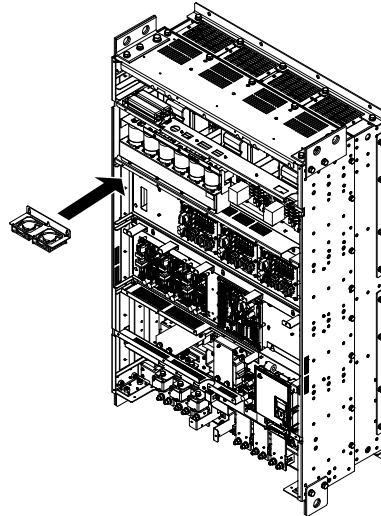

Figure 6.45 Installing the Control Board Cooling Fan Unit

2. Turn on the power supply and set o4-03 to 0 to reset the Maintenance Monitor control board cooling fan operation time.

◆ Drive Cooling Fan Replacement: Models 4□0720 to 4□0930

WARNING! *Electrical Shock Hazard. Do not connect or disconnect wiring while the power is on. Failure to comply can result in serious personal injury. Before servicing the drive, disconnect all power to the equipment. The internal capacitor remains charged even after the power supply is turned off. After shutting off the power, wait for at least the amount of time specified on the drive before touching any components.*

CAUTION! Burn Hazard. Do not touch a hot drive heatsink. Failure to comply could result in minor or moderate injury. Shut off the power to the drive when replacing the cooling fan. To prevent burns, wait at least 15 minutes and ensure the heatsink has cooled down.

NOTICE: Prevent Equipment Damage. Follow cooling fan and circulation fan replacement instructions. Improper fan replacement could cause damage to equipment. Follow the instructions and replace the entire unit when replacing the cooling fan.

■ Removing the Cooling Fan Unit

CAUTION! Crush Hazard. Do not completely remove the cover screws, just loosen them. If the cover screws are removed completely, the terminal cover may fall off causing an injury. Take special care when removing/reattaching the terminal covers for larger drives.

1. Loosen the 10 screws that hold drive cover 1 in place and free it from the drive.

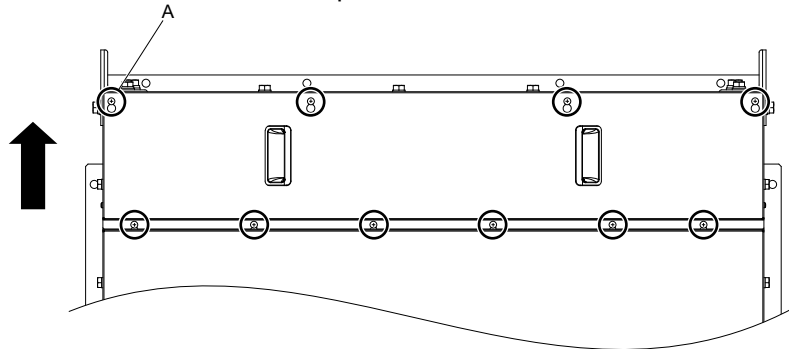

A -10 screw locations

Figure 6.46 Loosen the Screws and Remove Drive Cover 1

2. Loosen the 11 screws that hold the terminal cover in place and free it from the drive.

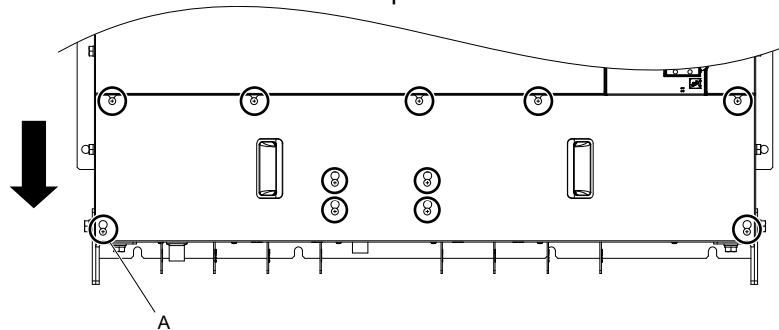

A -11 screw locations

Figure 6.47 Loosen the Screws and Remove the Terminal Cover

3. Loosen the 16 screws that hold the drive cover 2 in place and free it from the drive.

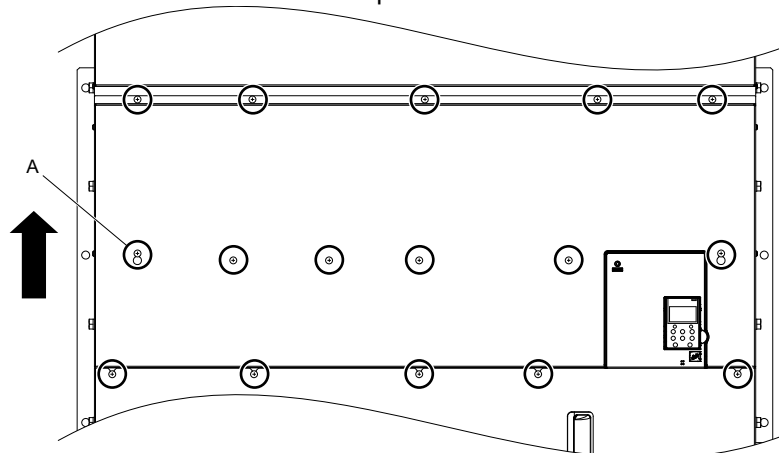

A -16 screw locations

Figure 6.48 Loosen the Screws and Remove Drive Cover 2

4. Loosen the 23 screws that hold the drive cover 3 in place and free it from the drive.

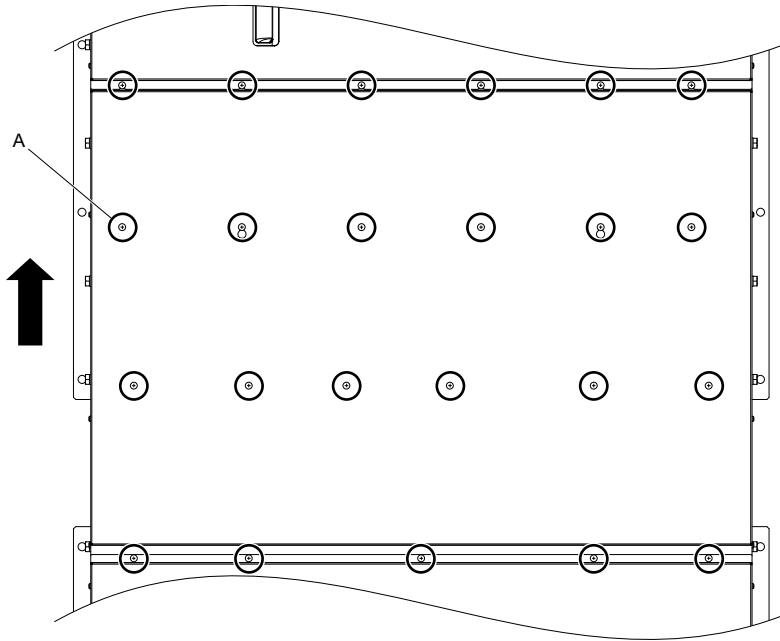

A –23 screw locations

Figure 6.49 Loosen the Screws and Remove Drive Cover 3

5. Unplug the relay connectors and free the cable from the cooling fan unit.

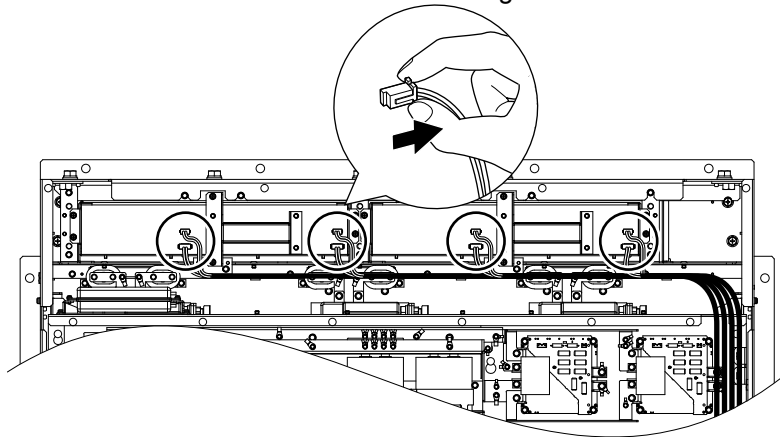
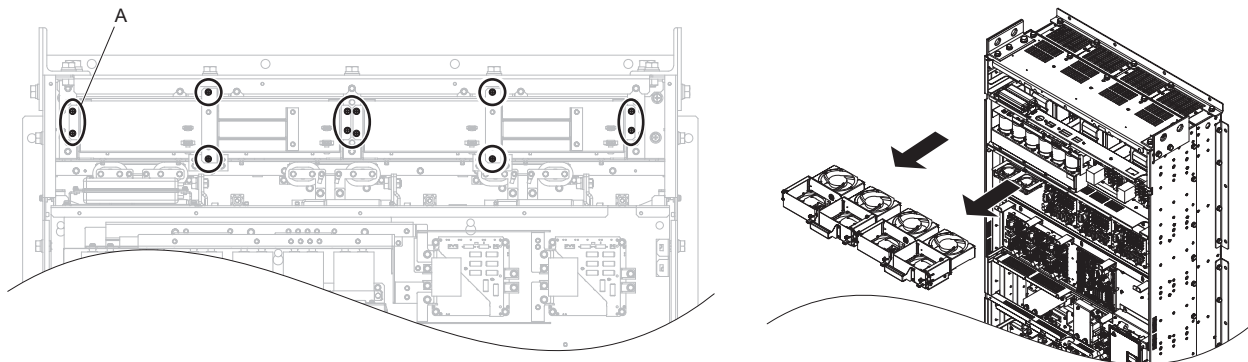

Figure 6.50 Unplug the Relay Connectors

6. Loosen the 12 screws, then slide the cooling fan unit and carefully pull it out.



A –12 screw locations

Figure 6.51 Remove the Cooling Fan Unit

■ Installing the Cooling Fan Unit

CAUTION! *Crush Hazard. Do not completely remove the cover screws, just loosen them. If the cover screws are removed completely, the terminal cover may fall off causing an injury. Take special care when removing/reattaching the terminal covers for larger drives.*

1. Reverse the procedure described above to install the replacement cooling fan unit.

- Note:**
1. Replace the whole unit when performing maintenance on the cooling fans.
 2. Do not pinch the fan cable between parts when reassembling the fan unit.
 3. Tighten the screws firmly so they do not come loose.

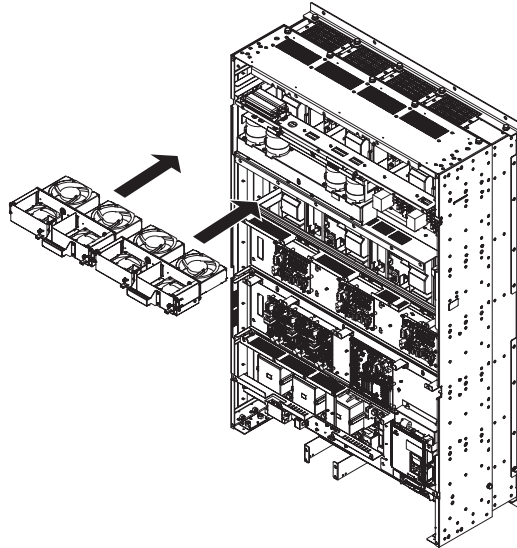

Figure 6.52 Installing the Cooling Fan Unit

2. Turn on the power supply and set o4-03 to 0 to reset the Maintenance Monitor circulation fan operation time.

■ Removing the Control Board Cooling Fan Unit

1. Unplug the relay connectors and free the cable from the control board cooling fan unit.

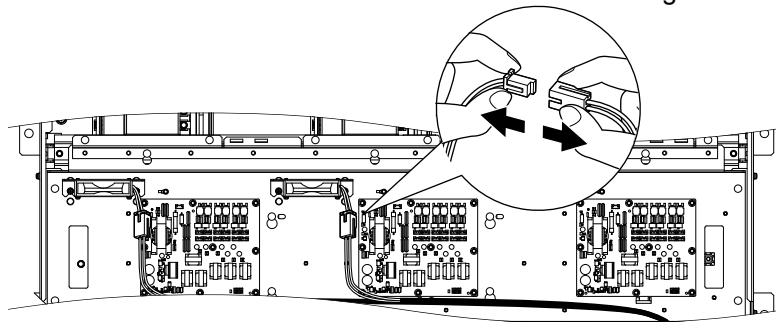
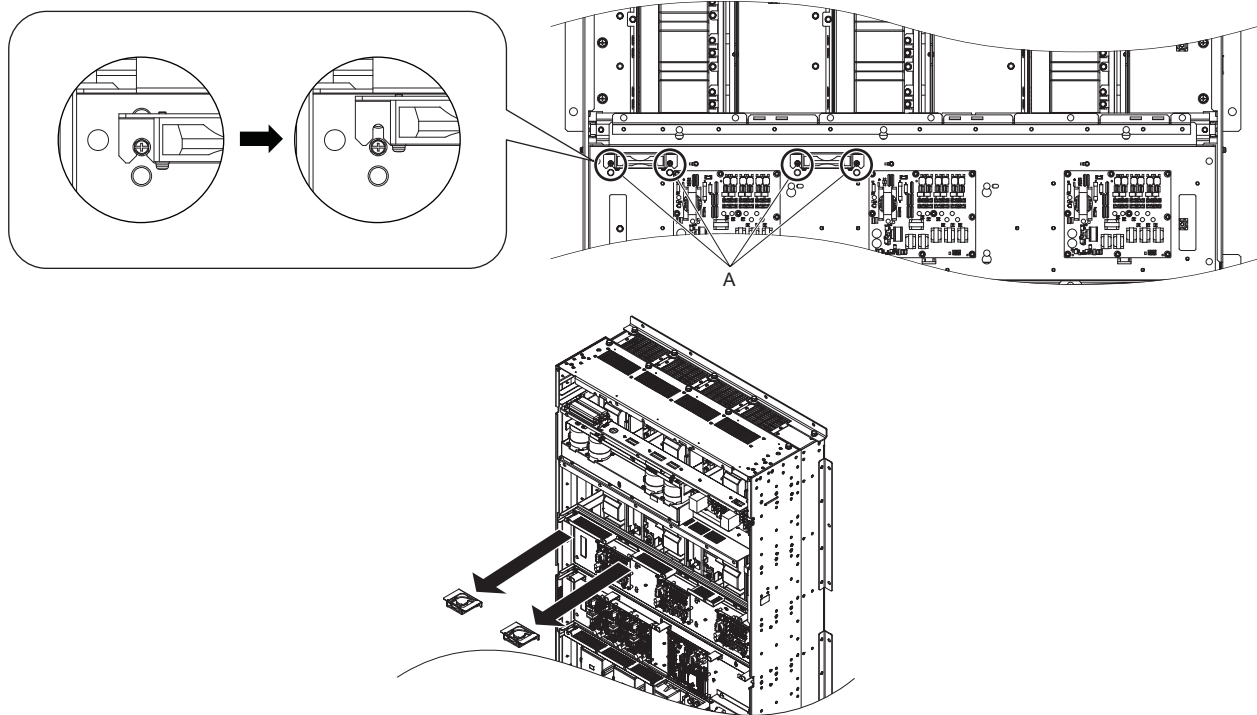

Figure 6.53 Unplug the Relay Connectors

2. Loosen the 4 screws, then slide the control board cooling fan unit and carefully pull it out.



A –4 screw locations

Figure 6.54 Remove the Control Board Cooling Fan Unit

■ Installing the Control Board Cooling Fan Unit

CAUTION! *Crush Hazard. Do not completely remove the cover screws, just loosen them. If the cover screws are removed completely, the terminal cover may fall off causing an injury. Take special care when removing/reattaching the terminal covers for larger drives.*

1. Reverse the procedure described above to install the replacement control board cooling fan unit.

- Note:**
1. Replace the whole unit when performing maintenance on the control board cooling fans.
 2. Do not pinch the fan cable between parts when reassembling the fan unit.
 3. Tighten the screws firmly so they do not come loose.

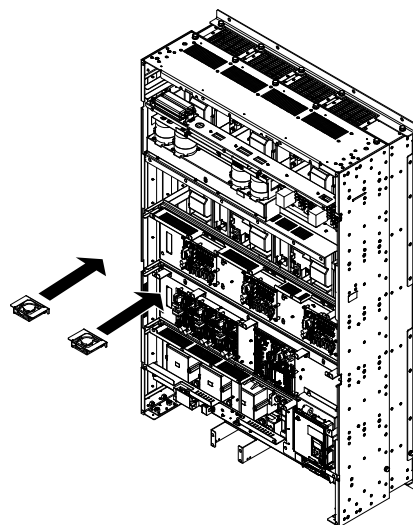

Figure 6.55 Installing the Control Board Cooling Fan Unit

2. Turn on the power supply and set o4-03 to 0 to reset the Maintenance Monitor control board cooling fan operation time.

◆ Harmonic Filter Module Cooling Fan Replacement

WARNING! Electrical Shock Hazard. Do not connect or disconnect wiring while the power is on. Failure to comply can result in serious personal injury. Before servicing the harmonic filter module, disconnect all power to the equipment. The internal capacitor remains charged even after the power supply is turned off. After shutting off the power, wait for at least the amount of time specified on the harmonic filter module before touching any components.

CAUTION! Burn Hazard. Do not touch a hot harmonic filter module heatsink. Failure to comply could result in minor or moderate injury. Shut off the power to the harmonic filter module when replacing the cooling fan. To prevent burns, wait at least 15 minutes and ensure the heatsink has cooled down.

NOTICE: Prevent Equipment Damage. Follow cooling fan and circulation fan replacement instructions. Improper fan replacement could cause damage to equipment. Follow the instructions and replace the entire unit when replacing the cooling fan.

■ Removing the Cooling Fan Unit

CAUTION! Crush Hazard. Do not completely remove the cover screws, just loosen them. If the cover screws are removed completely, the terminal cover may fall off causing an injury. Take special care when removing/reattaching the terminal covers for larger harmonic filter modules.

1. Loosen the 6 screws that hold harmonic filter module cover 1 in place and free it from the harmonic filter module.

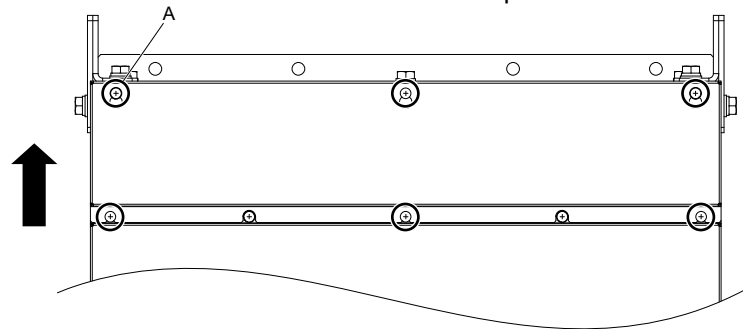

A –6 screw locations

Figure 6.56 Loosen the Screws and Remove Harmonic Filter Module Cover 1

2. Loosen the 9 screws that hold the terminal cover in place and free it from the harmonic filter module.

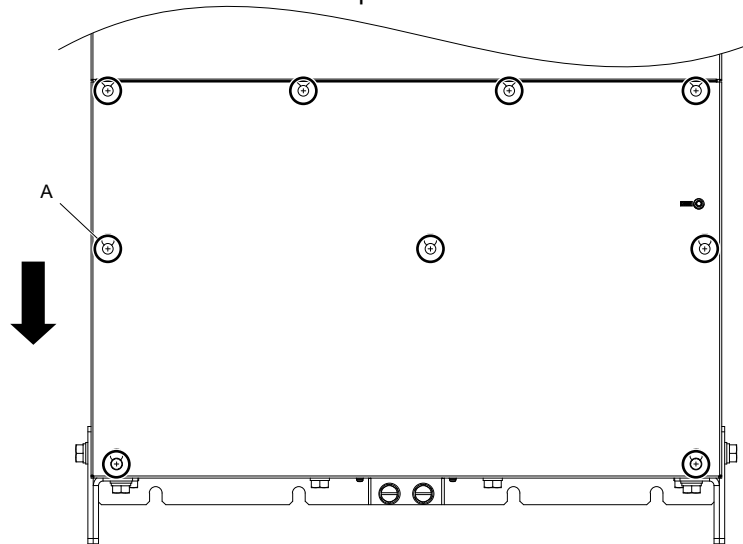

A –9 screw locations

Figure 6.57 Loosen the Screws and Remove the Terminal Cover

3. Loosen the 14 screws that hold the harmonic filter module cover 2 in place and free it from the harmonic filter module.

CAUTION! Crush Hazard. Do not completely remove the cover screws, just loosen them. If the cover screws are removed completely, the terminal cover may fall off causing an injury. Take special care when removing/reattaching the terminal covers for larger harmonic filter modules.

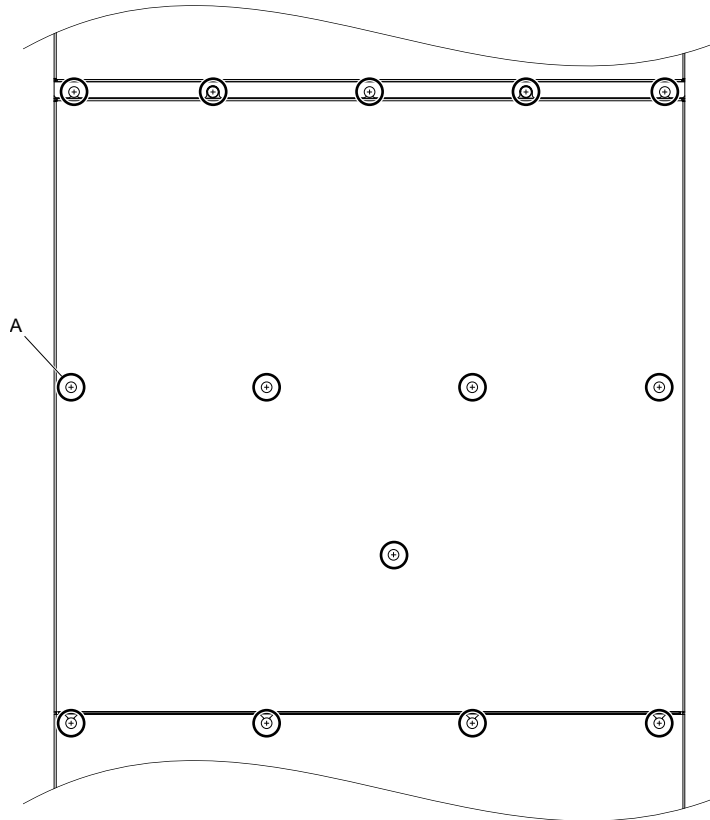

A –14 screw locations

Figure 6.58 Loosen the Screws and Remove Harmonic Filter Module Cover 2

4. Unplug the relay connectors and free the cable from the cooling fan unit.

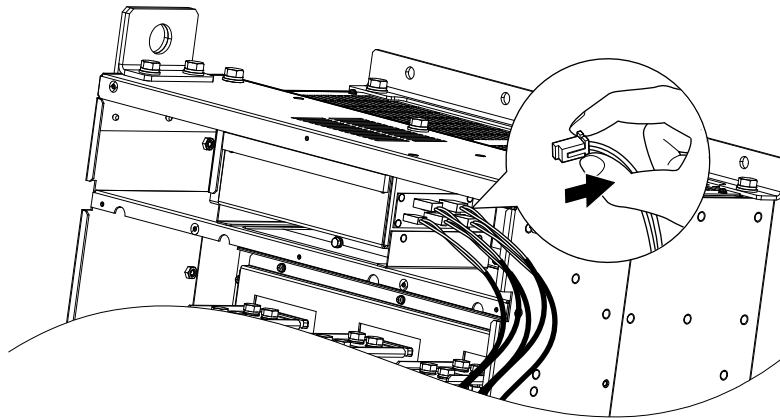
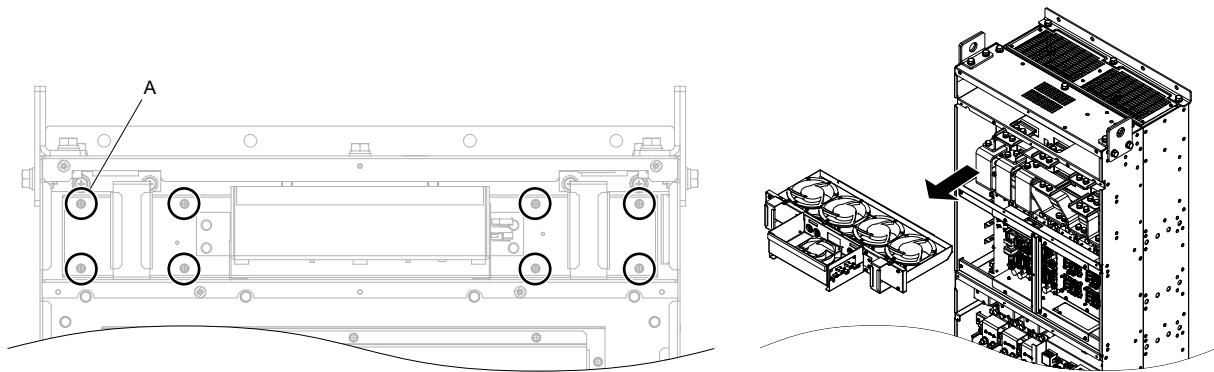

Figure 6.59 Unplug the Relay Connectors

5. Loosen the 8 screws, then slide the cooling fan unit and carefully pull it out.



A –8 screw locations

Figure 6.60 Remove the Cooling Fan Unit

■ Installing the Cooling Fan Unit

CAUTION! Crush Hazard. Do not completely remove the cover screws, just loosen them. If the cover screws are removed completely, the terminal cover may fall off causing an injury. Take special care when removing/reattaching the terminal covers for larger harmonic filter modules.

1. Reverse the procedure described above to install the replacement cooling fan unit.

- Note:**
1. Replace the whole unit when performing maintenance on the cooling fans.
 2. Do not pinch the fan cable between parts when reassembling the fan unit.
 3. Tighten the screws firmly so they do not come loose.

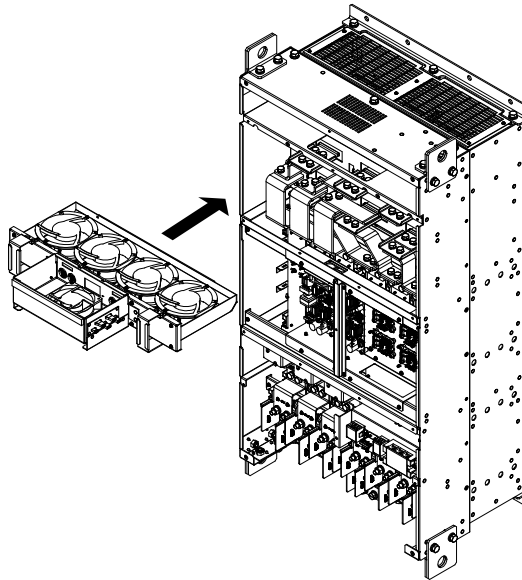

Figure 6.61 Installing the Cooling Fan Unit

2. Guide the cables through the second set of provided hooks to hold the cables in place.

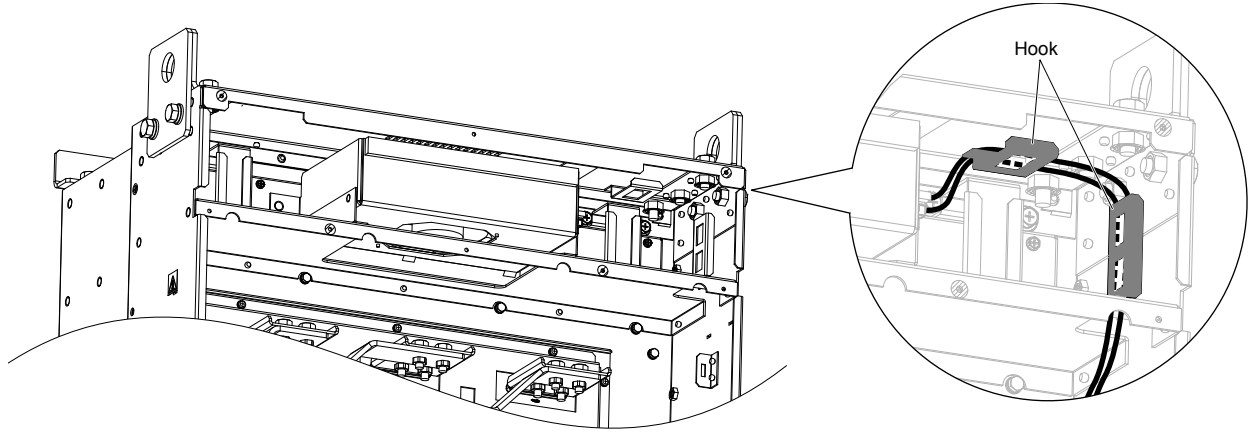

Figure 6.62 Route the Cooling Fan Wire

3. Turn on the power supply and set o4-03 to 0 to reset the Maintenance Monitor circulation fan operation time.

■ Removing the Control Board Cooling Fan Unit

1. Unplug the relay connector and free the cable from the control board cooling fan unit.

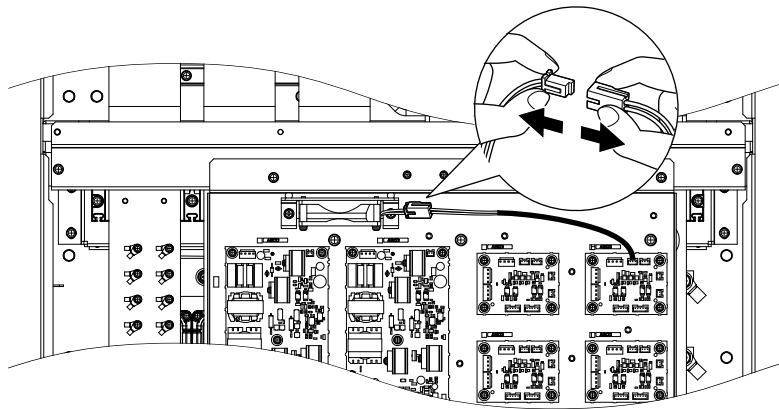
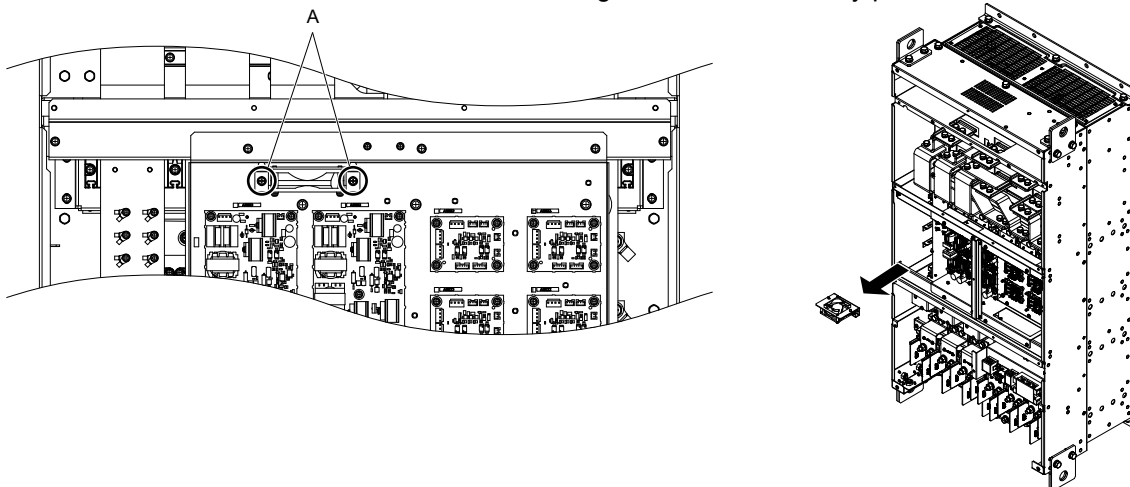

Figure 6.63 Unplug the Relay Connector

2. Loosen the 2 screws, then slide the control board cooling fan unit and carefully pull it out.



A –2 screw locations

Figure 6.64 Remove the Control Board Cooling Fan Unit

■ Installing the Control Board Cooling Fan Unit

CAUTION! *Crush Hazard. Do not completely remove the cover screws, just loosen them. If the cover screws are removed completely, the terminal cover may fall off causing an injury. Take special care when removing/reattaching the terminal covers for larger harmonic filter modules.*

1. Reverse the procedure described above to install the replacement control board cooling fan unit.

- Note:**
1. Replace the whole unit when performing maintenance on the control board cooling fans.
 2. Place the cables back into the hooks to secure.
 3. Do not pinch the fan cable between parts when reassembling the fan unit.
 4. Tighten the screws firmly so they do not come loose.

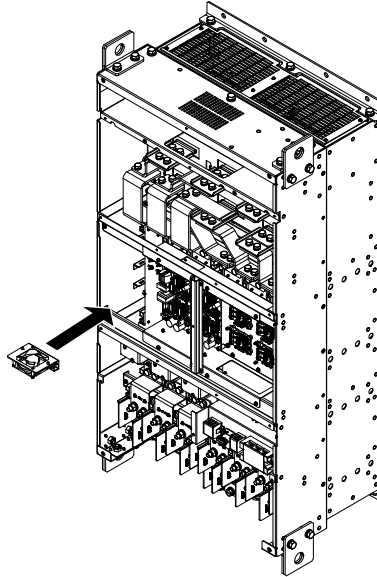

Figure 6.65 Installing the Control Board Cooling Fan Unit

2. Turn on the power supply and set o4-03 to 0 to reset the Maintenance Monitor control board cooling fan operation time.

6.5 Drive Replacement

◆ Replacing the Drive

WARNING! Electrical Shock Hazard. Do not connect or disconnect wiring while the power is on. Failure to comply can result in serious personal injury. Before servicing the drive, disconnect all power to the equipment. The internal capacitor remains charged even after the power supply is turned off. After shutting off the power, wait for at least the amount of time specified on the drive before touching any components.

WARNING! Electrical Shock Hazard. Do not allow unqualified personnel to perform work on the drive. Failure to comply could result in serious injury. Installation, maintenance, inspection and servicing must be performed only by authorized personnel familiar with installation, adjustment and maintenance of AC drives.

NOTICE: Observe proper electrostatic discharge procedures (ESD) when handling the drive and circuit boards. Failure to comply may result in ESD damage to the drive circuitry.

The following procedure explains how to replace a drive.

This section provides instructions for drive replacement only.

To install option boards or other types of options, refer to the specific manuals for those options.

NOTICE: When transferring a braking transistor, braking resistor, or other type of option from a damaged drive to a new replacement drive, make sure it is working properly before reconnecting it to the new drive. Replace broken options to prevent immediate breakdown of the replacement drive.

1. Remove the terminal cover.

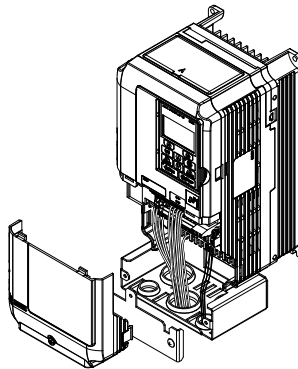

Figure 6.66 Remove the Terminal Cover

2. Loosen the screws holding the terminal board in place. Remove the screw securing the bottom cover and remove the bottom cover from the drive.

Note: IP00/Open Type enclosure drives do not have a bottom cover or conduit.

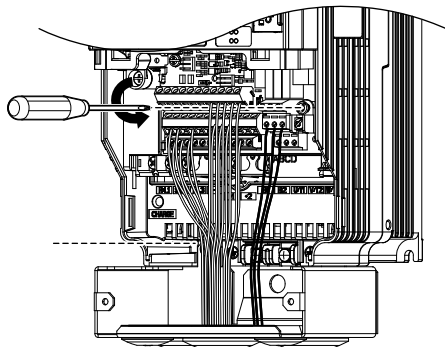

Figure 6.67 Unscrew the Terminal Board and Remove the Bottom Cover

3. Slide the terminal board as illustrated by the arrows to remove it from the drive along with the bottom cover.

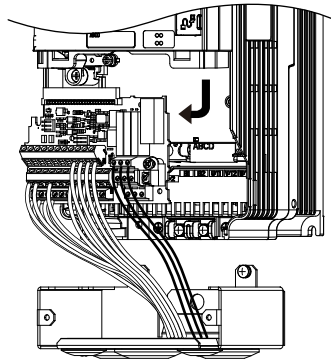

Figure 6.68 Remove the Terminal Board

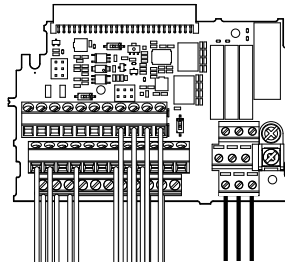

Figure 6.69 Disconnected Removable Terminal Board

4. Disconnect all option cards and options, making sure they are intact before reusing.
5. Replace the drive and wire the main circuit.

■ Installing the Drive

1. After wiring the main circuit, connect the terminal block to the drive as shown in [Figure 6.70](#). Use the installation screw to fasten the terminal block into place.

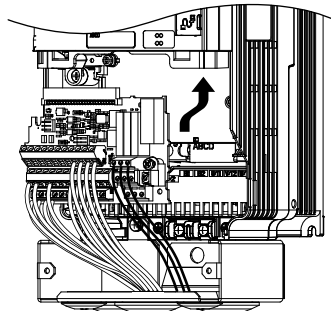

Figure 6.70 Install the Terminal Board

2. Reconnect options for the new drive the same way the options were connected in the old drive. Connect option boards to the same option ports in the new drive that were used in the old drive.
3. Replace the terminal cover.
4. After powering on the drive, all parameter settings are transferred from the terminal board to the drive memory. If an oPE04 error occurs, load the parameter settings saved on the terminal board to the new drive by setting parameter A1-03 to 5550. Reset the Maintenance Monitor function timers by setting parameters o4-01 through o4-12 to 0, and parameter o4-13 to 1.

This Page Intentionally Blank

Peripheral Devices & Options

This chapter explains the installation of peripheral devices and options available for the drive.

7.1	SECTION SAFETY.....	292
7.2	DRIVE OPTIONS AND PERIPHERAL DEVICES.....	294
7.3	CONNECTING PERIPHERAL DEVICES.....	295
7.4	OPTION INSTALLATION.....	297
7.5	INSTALLING PERIPHERAL DEVICES.....	301

7.1 Section Safety

DANGER

Electrical Shock Hazard

Before servicing, disconnect all power to the equipment.

The capacitor for the internal power supply remains charged even after the power supply is turned off. The charge indicator LED will extinguish when the control power supply voltage is below 50 Vdc. To prevent electric shock, wait for at least the time specified on the warning label, once all indicators are OFF, measure for unsafe voltages to confirm the drive is safe prior to servicing.

Failure to comply will result in death or serious injury.

WARNING

Electrical Shock Hazard

Do not operate equipment with covers removed.

Failure to comply could result in death or serious injury.

The diagrams in this section may show drives without covers or safety shields to show details. Be sure to reinstall covers or shields before operating the drives and run the drives according to the instructions described in this manual.

Do not remove covers or touch circuit boards while the power is on.

Failure to comply could result in death or serious injury.

Do not allow unqualified personnel to perform work on the drive.

Failure to comply could result in death or serious injury.

Installation, maintenance, inspection, and service must be performed only by authorized personnel familiar installation, adjustment, and maintenance of drives.

Do not perform work on the drive while wearing loose clothing, jewelry or without eye protection.

Failure to comply could result in death or serious injury.

Remove all metal objects such as watches and rings, secure loose clothing and wear eye protection before beginning work on the drive.

Always ground the motor-side grounding terminal.

Improper equipment grounding could result in death or serious injury by contacting the motor case.

Do not remove covers or touch circuit boards while the power is on.

Failure to comply could result in death or serious injury.

Do not use damaged wires, place excessive stress on wiring, or damage the wire insulation.

Failure to comply could result in death or serious injury.

Fire Hazard

Tighten all terminal screws to the specified tightening torque.

Loose electrical connections could result in death or serious injury by fire due to overheating of electrical connections.

NOTICE

Observe proper electrostatic discharge procedures (ESD) when handling the drive and circuit boards.

Failure to comply may result in ESD damage to the drive circuitry.

Never connect or disconnect the motor from the drive while the drive is outputting voltage.

Improper equipment sequencing could result in damage to the drive.

If a fuse is blown or a Ground Fault Circuit Interrupter (GFCI) is tripped, check the wiring and the selection of the peripheral devices.

Contact your supplier if the cause cannot be identified after checking the above.

Do not restart the drive or immediately operate the peripheral devices if a fuse is blown or a GFCI is tripped.

Check the wiring and the selection of peripheral devices to identify the cause. Contact your supplier before restarting the drive or the peripheral devices if the cause cannot be identified.

Do not operate damaged equipment.

Failure to comply could result in further damage to the equipment.

Do not connect or operate any equipment with visible damage or missing parts.

Do not use unshielded wire for control wiring.

Failure to comply may cause electrical interference resulting in poor system performance. Use shielded twisted-pair wires and ground the shield to the ground terminal of the drive.

Properly connect all pins and connectors.

Failure to comply may prevent proper operation and possibly damage equipment.

Check all the wiring to ensure that all connections are correct after installing the option and connecting any other devices.

Failure to comply could result in damage to the option.

7.2 Drive Options and Peripheral Devices

Table 7.1 lists the names of the various peripheral devices, accessories, and options available for Yaskawa drives. Contact Yaskawa or your Yaskawa agent to order these peripheral devices.

- **Peripheral Device Selection:** Refer to the Yaskawa catalog for selection and part numbers.
- **Peripheral Device Installation:** Refer to the corresponding option manual for installation instructions.

Table 7.1 Available Peripheral Devices

Option	Model Number	Description
Input/Output Option Cards		
Analog Monitor	AO-A3	<ul style="list-style-type: none"> • Provides extra multi-function analog output terminals • Output channels: 2 • Output voltage: -10 to 10 V, 11-bit (signed)
Digital Output	DO-A3	<ul style="list-style-type: none"> • Provides extra insulated multi-function digital outputs • Photocoupler relays: 6 (48 V, up to 50 mA) • Contact relays: 2 (250 Vac/up to 1 A, 30 Vdc/up to 1 A)
Communication Option Cards		
EtherNet/IP	SI-EN3	Connects to an EtherNet/IP network.
Modbus TCP/IP	SI-EM3	Connects to a Modbus TCP/IP network.
PROFINET	SI-EP3	Connects to a PROFINET network.
DeviceNet	SI-N3	Connects to a DeviceNet network
PROFIBUS-DP	SI-P3	Connects to a PROFIBUS-DP network.
Interface Options		
Remote Control Extension Cable	UWR000051, 1 m cable UWR000052, 2 m cable	RJ-45, 8-pin straight through, UTP CAT5e, extension cable (1 m or 2 m) to connect the digital operator for remote operation.
USB Copy Unit	JVOP-181	<ul style="list-style-type: none"> • Allows the user to copy and verify parameter settings between drives. • Functions as an adapter to connect the drive to a USB port on a PC.
Mechanical Options		
IP20/NEMA 1, UL Type 1 Kit	EZZ022745A-F	Parts to make the drive conform to IP20/NEMA 1, UL Type 1 enclosure requirements.
IP20/NEMA 1, UL Type 1, 4, 12 Blank Keypad Kit	UUX0000526	Provides digital operator functionality on an enclosure designed for IP20/NEMA 1, UL Type 1, 3R, 4, 4X, 12, or IP□6 environment. This keypad has a blank label on the front.
IP20/NEMA 1, UL Type 1, 4, 12 Yaskawa Logo Keypad Kit	UUX0000527	Provides digital operator functionality on an enclosure designed for IP20/NEMA 1, UL Type 1, 3R, 4, 4X, 12, or IP□6 environment. This keypad has a Yaskawa brand label on the front.
PC Software Tools		
DriveWizard Industrial	Contact Yaskawa	PC tool for drive setup and parameter management

7.3 Connecting Peripheral Devices

Figure 7.1 illustrates how to configure the drive and motor to operate with various peripheral devices.

Refer to the specific manual for the devices shown below for installation instructions.

Note: If the drive is set to trigger a fault output when the fault restart function is activated (L5-02 = 1), then a sequence to interrupt power when a fault occurs will turn off the power to the drive while the drive attempts to restart. The default setting for L5-02 is 0 (fault output active during restart).

◆ Drive Models 2□0028 to 2□0248 and 4□0011 to 4□0590

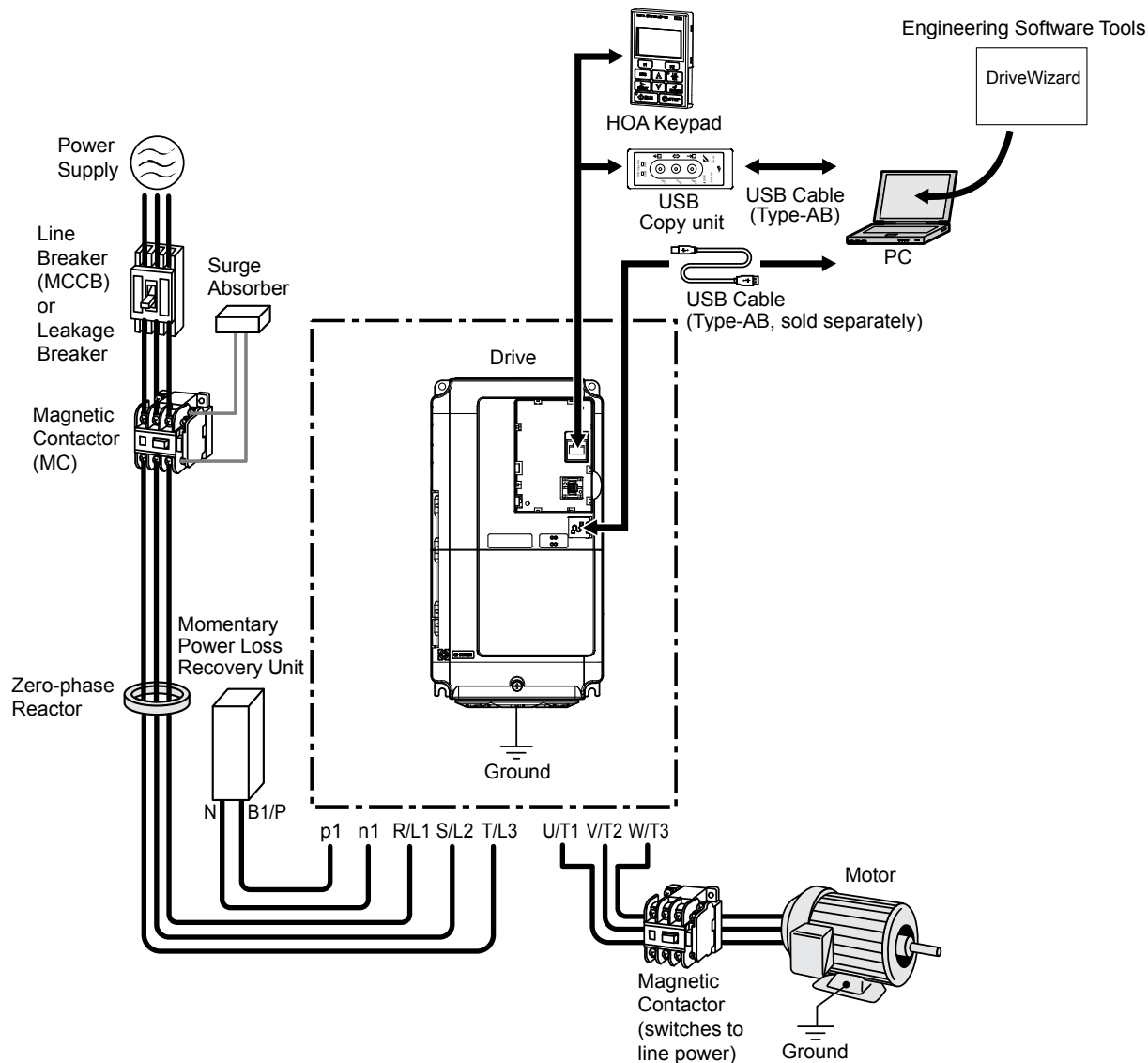

Figure 7.1 Connecting Peripheral Devices to Drive Model 2□0028

◆ Drive Models 4□0720 to 4□0930

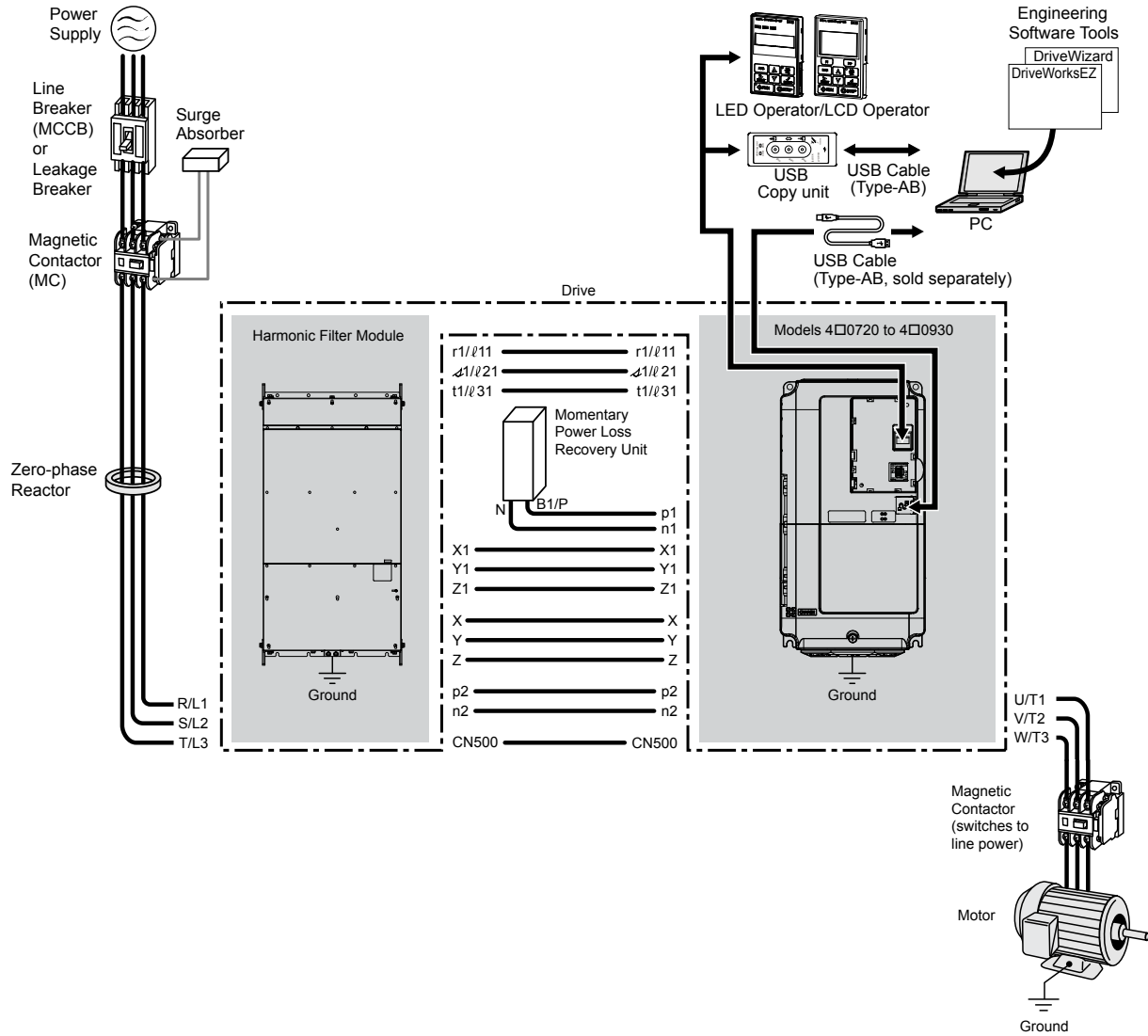

Figure 7.2 Connecting Peripheral Devices to Drive Model 4□0720

7.4 Option Installation

This section provides instructions on installing the options in [Table 7.2](#).

◆ Prior to Installing the Option

Prior to installing the option, wire the drive, make necessary connections to the drive terminals, and verify that the drive functions normally without the option installed.

[Table 7.2](#) below lists the number of options that can be connected to the drive and the drive ports for connecting those options.

Table 7.2 Option Installation

Option	Port/Connector	Number of Options Possible
AO-A3, DO-A3	CN5-A, B, C	1
SI-EN3, SI-EM3, SI-EP3, SI-ES3, SI-ET3, SI-N3, SI-P3, AI-A3, DI-A3	CN5-A	1

[Figure 7.3](#) shows an exploded view of the drive with the option and related components for reference.

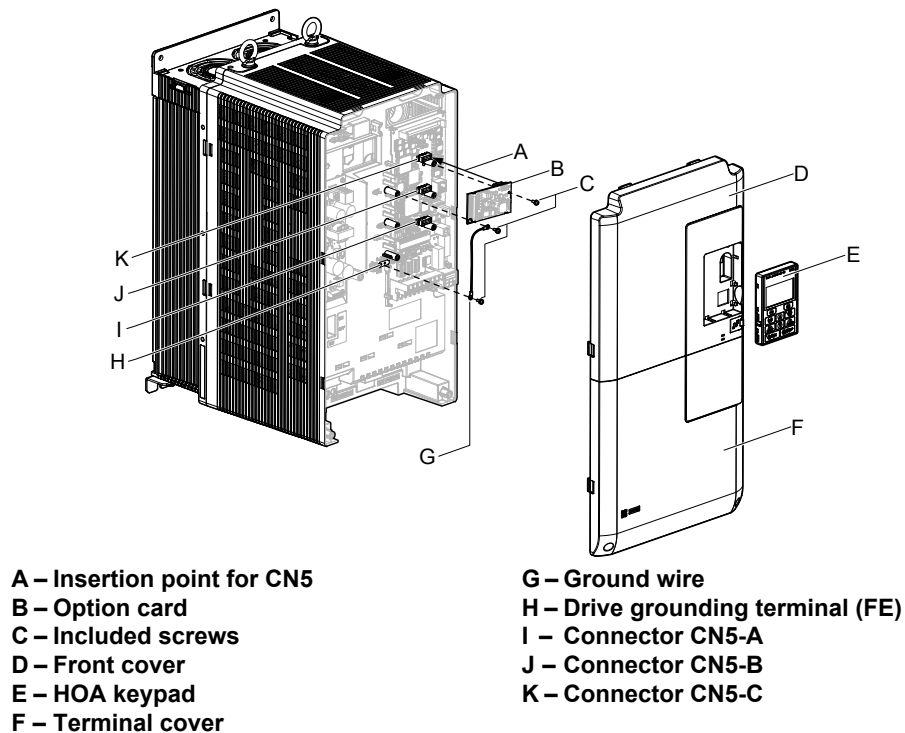

Figure 7.3 Drive Components with Option

◆ Communication Option Installation Example

Remove the front covers of the drive before installing the option. Communication options can be inserted only into the CN5-A connector located on the drive control board.

Preparing the Drive

1. Shut off power to the drive, wait the appropriate amount of time for voltage to dissipate, then remove the HOA keypad (E) and front covers (D, F). Front cover removal varies by model.

DANGER! Electrical Shock Hazard. Do not connect or disconnect wiring while the power is on. Failure to comply will result in death or serious injury. Before installing the option, disconnect all power to the drive. The internal capacitor remains charged even after the power supply is turned off. The charge indicator LED will extinguish when the DC bus voltage is below 50 Vdc. To prevent electric shock, wait at least five minutes after all indicators are off and measure the DC bus voltage level to confirm safe level.

NOTICE: Damage to Equipment. Observe proper electrostatic discharge procedures (ESD) when handling the option, drive, and circuit boards. Failure to comply may result in ESD damage to circuitry.

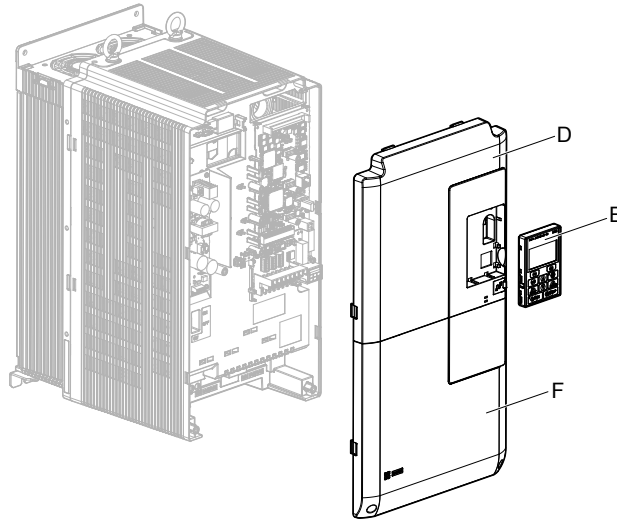

Figure 7.4 Remove the Front Covers and HOA Keypad

Connecting Option and Ground Wire

1. Insert the option (B) into the **CN5-A** connector (K) located on the drive and fasten it using one of the included screws (C).

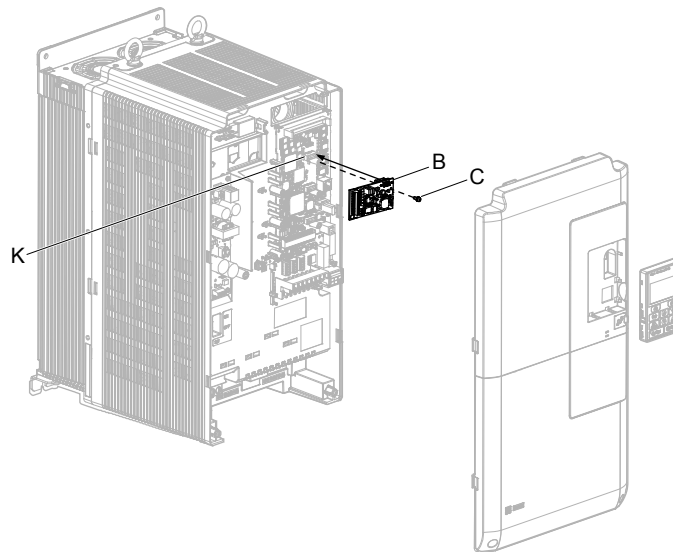

Figure 7.5 Insert the Option

2. Connect the ground wire (G) to the ground terminal (H) using one of the remaining provided screws (C). Connect the other end of the ground wire (G) to the remaining ground terminal and installation hole on the option (B) using the last remaining provided screw (C) and tighten both screws to 0.5 to 0.6 N m or (4.4 to 5.3 in lbs).

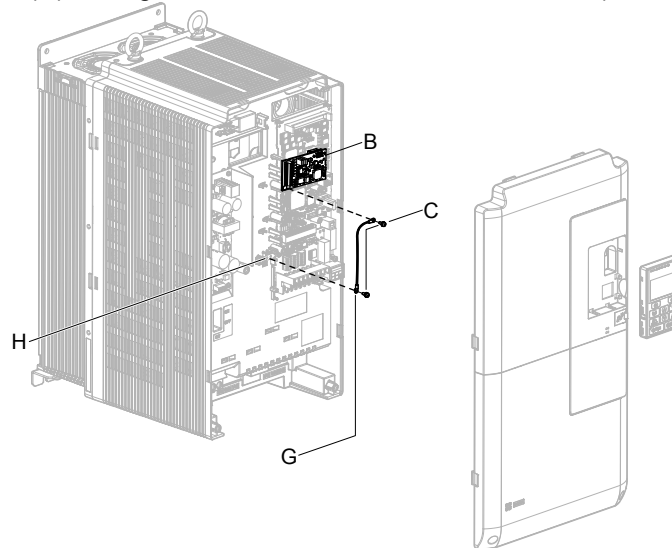

Figure 7.6 Connect the Ground Wire

Note: There are two screw holes on the drive for use as ground terminals. When connecting three options, two ground wires will need to share the same drive ground terminal.

Wiring the Option

1. Route the communication wiring inside the enclosure as shown in [Figure 7.7](#).

Note: Separate the communications cables from the main circuit cables and other wiring and power cables. Use properly grounded shielded cables for the communication cables to prevent problems caused by electrical interference.

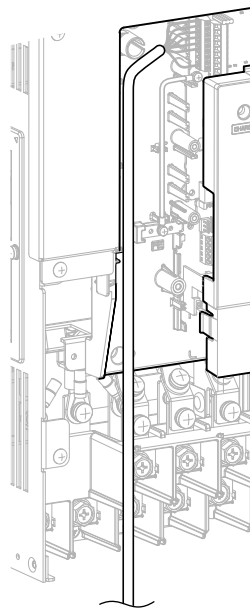

Figure 7.7

7.4 Option Installation

Replacing the Drive Covers and HOA Keypad

1. Replace and secure the front covers of the drive (D, F) and replace the HOA keypad (E).

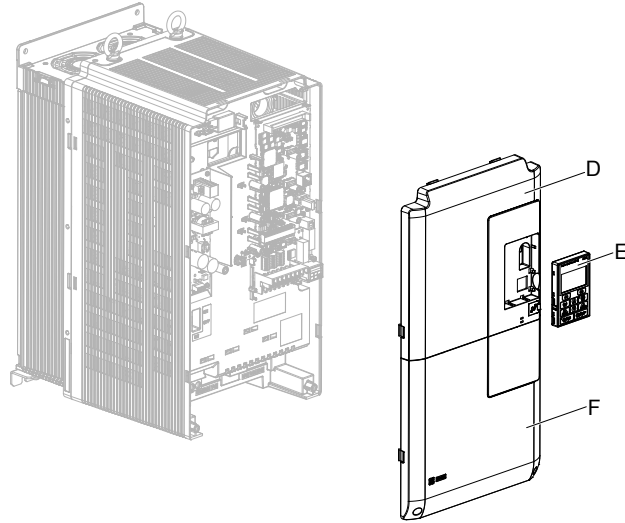

Figure 7.8 Replace the Front Covers and HOA Keypad

Note: Take proper precautions when wiring the option so that the front covers will easily fit back onto the drive. Make sure no cables are pinched between the front covers and the drive when replacing the covers.

7.5 Installing Peripheral Devices

This section describes the proper steps and precautions to take when installing or connecting various peripheral devices to the drive.

NOTICE: Use a class 2 power supply when connecting to the control terminals. Improper application of peripheral devices could result in drive performance degradation due to improper power supply. Refer to NEC Article 725 Class 1, Class 2, and Class 3 Remote-Control, Signaling, and Power Limited Circuits for requirements concerning class 2 power supplies.

◆ Installing a Molded Case Circuit Breaker (MCCB) or Ground Fault Circuit Interrupter (GFCI)

Install an MCCB or GFCI for line protection between the power supply and the main circuit power supply input terminals R/L1, S/L2, and T/L3. This protects the main circuit and devices wired to the main circuit while also providing overload protection.

Consider the following when selecting and installing an MCCB or GFCI:

- The capacity of the MCCB or GFCI should be 1.5 to 2 times the rated output current of the drive. Use an MCCB or GFCI to keep the drive from faulting out instead of using overheat protection (150% for one minute at the rated output current).
- If several drives are connected to one MCCB or GFCI that is shared with other equipment, use a sequence that shuts the power OFF when errors are output by using magnetic contactor (MC) as shown in [Figure 7.9](#).

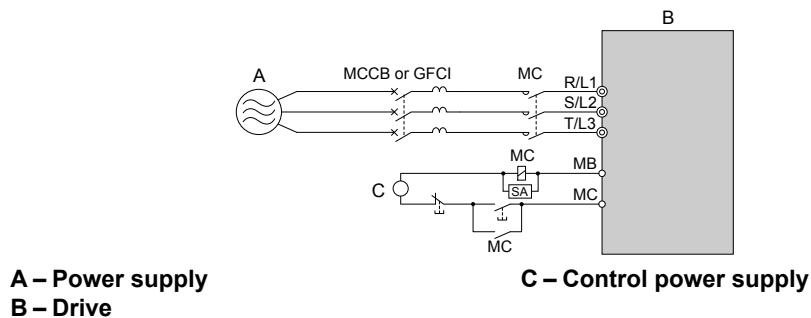

Figure 7.9 Power Supply Interrupt Wiring (Example)

WARNING! Electrical Shock Hazard. Disconnect the MCCB (or GFCI) and MC before wiring terminals. Failure to comply may result in serious injury or death.

■ Application Precautions when Installing a GFCI

Drive outputs generate high-frequency leakage current as a result of high-speed switching. Install a GFCI on the input side of the drive to switch off potentially harmful leakage current.

Factors in determining leakage current:

- Size of the AC drive
- AC drive carrier frequency
- Motor cable type and length
- EMI/RFI filter

If the GFCI trips spuriously, consider changing these items or use a GFCI with a higher trip level.

Note: Choose a GFCI designed specifically for an AC drive. The operation time should be at least 0.1 s with sensitivity amperage of at least 200 mA per drive.

◆ Installing a Magnetic Contactor at the Power Supply Side

Install a magnetic contactor (MC) to the drive input for the purposes explained below.

■ Disconnecting the Power Supply

Shut off the drive with an MC when a fault occurs in any external equipment such as braking resistors.

NOTICE: Do not connect electromagnetic switches or MCs to the output motor circuits without proper sequencing. Improper sequencing of output motor circuits could result in damage to the drive.

NOTICE: Install an MC on the input side of the drive when the drive should not automatically restart after power loss. To get the full performance life out of the capacitor for the control power supply and circuit relays, refrain from switching the drive power supply off and on more than once every 30 minutes. Frequent use can damage the drive. Use the drive to stop and start the motor.

7.5 Installing Peripheral Devices

NOTICE: Use a magnetic contactor (MC) to ensure that power to the drive can be completely shut off when necessary. The MC should be wired so that it opens when a fault output terminal is triggered.

- Note:**
1. Install an MC to the drive input side to prevent the drive from restarting automatically when power is restored after momentary power loss.
 2. Set up a delay that prevents the MC from opening prematurely to continue operating the drive through a momentary power loss.

◆ Connecting a Surge Absorber

A surge absorber suppresses surge voltage generated from switching an inductive load near the drive. Inductive loads include magnetic contactors, relays, valves, solenoids, and brakes. Always use a surge absorber or diode when operating with an inductive load.

WARNING! Fire Hazard. Due to surge absorber short circuit on drive output terminals U/T1, V/T2, and W/T3, do not connect surge absorbers to the drive output power terminals. Failure to comply may result in serious injury or death by fire or flying debris.

◆ Reducing Noise

■ Preventing Induced Noise

Use shielded cables or zero phase reactors and lay the cables at least 30 cm away from the signal line to prevent induced noise.

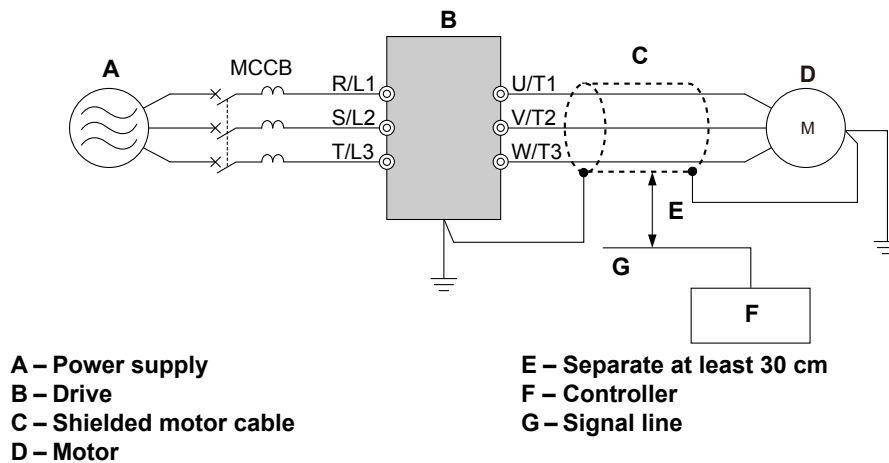

Figure 7.10 Preventing Induced Noise

◆ Attachment for External Heatsink Mounting (IP00 Enclosure)

An external attachment can be used to project the heatsink outside of an enclosure to ensure that there is sufficient air circulation around the heatsink.

Contact Yaskawa or a Yaskawa representative for more information on this attachment.

◆ Installing a Motor Thermal Overload (oL) Relay on the Drive Output

Motor thermal overload relays protect the motor by disconnecting power lines to the motor due to a motor overload condition.

Install a motor thermal overload relay between the drive and motor:

- When operating multiple motors on a single AC drive.
- When using a power line bypass to operate the motor directly from the power line.

It is not necessary to install a motor thermal overload relay when operating a single motor from a single AC drive. The AC drive has UL recognized electronic motor overload protection built into the drive software.

- Note:**
1. Disable the motor protection function (L1-01 = 0) when using an external motor thermal overload relay.
 2. Create a sequence to produce an external fault (coast to a stop) when triggered.

■ General Precautions when Using Thermal Overload Relays

Consider the following application precautions when using motor thermal overload relays on the output of AC drives to prevent nuisance trips or overheat of the motor at low speeds:

- Low speed motor operation
- Use of multiple motors on a single AC drive

- Motor cable length
- Nuisance tripping resulting from high AC drive carrier frequency

Low Speed Operation and Motor Thermal oL Relays

Generally, thermal relays are applied on general-purpose motors. When general-purpose motors are driven by AC drives, the motor current is approximately 5% to 10% greater than if driven by a commercial power supply. In addition, the cooling capacity of a motor with a shaft-driven fan decreases when operating at low speeds. Motor overheating may occur even when the load current is within the motor rated value. A thermal relay cannot effectively protect the motor due to the reduction of cooling at low speeds. For this reason, apply the UL recognized electronic thermal overload protection function built into the drive whenever possible.

UL recognized electronic thermal overload function of the drive: Speed-dependent heat characteristics are simulated using data from standard motors and force-ventilated motors. The motor is protected from overload using this function.

Using a Single Drive to Operate Multiple Motors

Set parameter L1-01 to 0 to disable thermal overload protection for the drive.

Note: The UL recognized electronic thermal overload function cannot be applied when operating multiple motors with a single drive.

Long Motor Cables

When a high carrier frequency and long motor cables are used, nuisance tripping of the thermal relay may occur due to increased leakage current. To avoid this, reduce the carrier frequency or increase the tripping level of the thermal overload relay.

Nuisance Tripping Due to a High AC Drive Carrier Frequency

Current waveforms generated by high carrier frequency drives tend to increase the temperature in overload relays. It may be necessary to increase the trip level setting when encountering nuisance triggering of the relay.

WARNING! Fire Hazard. Confirm an actual motor overload condition is not present prior to increasing the thermal oL trip setting. Check local electrical codes before making adjustments to motor thermal overload settings. Failure to comply could result in death or serious injury.

This Page Intentionally Blank

Appendix: A

Specifications

A.1	POWER RATINGS.....	306
A.2	DRIVE SPECIFICATIONS.....	311
A.3	DRIVE WATT LOSS DATA.....	313
A.4	DRIVE DERATING DATA.....	315

A.1 Power Ratings

◆ Three-Phase 200 V Class Drive Models 2□0028 to 2□0081

Table A.1 Power Ratings (Three-Phase 200 V Class)

Item		Specification				
Drive Model		2□0028	2□0042	2□0054	2□0068	2□0081
Maximum Applicable Motor Capacity kW (HP) <1>		7.5 (10)	11 (15)	15 (20)	18.5 (25)	22 (30)
Input/Output Rating	Rated Input Current (A) <2>	25	38	49	62	74
	Rated Input Capacity (kVA) <3>	12	17	22	28	34
	Rated Output Current (A) <4> <5>	28	42	54	68	81
	Overload Tolerance	Rating: 120% of rated output current for 60 s (Derating may be required for applications that start and stop frequently)				
	Carrier Frequency	4 kHz (User adjustable up to 10 kHz. Derating may be required.)				
	Maximum Output Voltage (V)	Proportional to input voltage <6>				
	Maximum Output Frequency (Hz)	400 Hz (User-adjustable)				
Power Supply	Rated Voltage Rated Frequency	Three-phase 200 to 240 Vac 50/60 Hz				
	Allowable Voltage Fluctuation	-15 to 10%				
	Allowable Frequency Fluctuation	±3% (Frequency fluctuation rate: 1 Hz/100 ms or less)				
	Allowable Phase Power Supply Voltage Unbalance	2% or less				
Harmonic Current Distortion <6>		5% or less (IEEE519 compliant)				
Input Power Factor		0.98 or more (During rated operation)				

- <1> The motor capacity (HP) refers to an NEC 4-pole motor. The rated output current of the drive should be equal to or greater than the motor current. Select the appropriate capacity drive if operating the motor continuously above motor nameplate current.
- <2> Assumes operation at the rated output current. Input current rating varies depending on the power supply transformer, input reactor, wiring connections, and power supply impedance.
- <3> Rated input capacity is calculated with a power line voltage of $240\text{ V} \times 1.1$.
- <4> The rated output current of the drive should be equal to or greater than the motor rated current.
- <5> Carrier frequency is set to 4 kHz. Current derating is required to raise the carrier frequency.
- <6> Commercial power mode results in near zero input harmonics. Existing power conditions and operation mode can affect input harmonics.

◆ Three-Phase 200 V Class Drive Models 2□0104 to 2□0248

Table A.2 Power Ratings (Three-Phase 200 V Class) Continued

Item		Specification				
Drive Model		2□0104	2□0130	2□0154	2□0192	2□0248
Maximum Applicable Motor Capacity kW (HP) <1>		30 (40)	37 (50)	45 (60)	55 (75)	75 (100)
Input/Output Rating	Rated Input Current (A) <2>	95	118	140	175	226
	Rated Input Capacity (kVA) <3>	43	54	64	80	103
	Rated Output Current (A) <4> <5>	104	130	154	192	248
	Overload Tolerance	Rating: 120% of rated output current for 60 s (Derating may be required for applications that start and stop frequently)				
	Carrier Frequency	4 kHz (User adjustable up to 8 kHz. Derating may be required.)				4 kHz
	Maximum Output Voltage (V)	Proportional to input voltage <6>				
	Maximum Output Frequency (Hz)	400 Hz (User-adjustable)				
Power Supply	Rated Voltage Rated Frequency	Three-phase 200 to 240 Vac 50/60 Hz				
	Allowable Voltage Fluctuation	-15 to 10%				
	Allowable Frequency Fluctuation	±3% (Frequency fluctuation rate: 1 Hz/100 ms or less)				
	Allowable Phase Power Supply Voltage Unbalance	2% or less				
Harmonic Current Distortion <6>		5% or less (IEEE519 compliant)				
Input Power Factor		0.98 or more (During rated operation)				

<1> The motor capacity (HP) refers to an NEC 4-pole motor. The rated output current of the drive should be equal to or greater than the motor current. Select the appropriate capacity drive if operating the motor continuously above motor nameplate current.

<2> Assumes operation at the rated output current. Input current rating varies depending on the power supply transformer, input reactor, wiring connections, and power supply impedance.

<3> Rated input capacity is calculated with a power line voltage of $240\text{ V} \times 1.1$.

<4> The rated output current of the drive should be equal to or greater than the motor rated current.

<5> Carrier frequency is set to 4 kHz. Current derating is required to raise the carrier frequency.

<6> Commercial power mode results in near zero input harmonics. Existing power conditions and operation mode can affect input harmonics.

A.1 Power Ratings

◆ Three-Phase 400 V Class Drive Models 4□0011 to 4□0077

Table A.3 Power Ratings (Three-Phase 400 V Class)

Item		Specification								
Drive Model		4□0011	4□0014	4□0021	4□0027	4□0034	4□0040	4□0052	4□0065	4□0077
Maximum Applicable Motor Capacity kW (HP) <1>		5.5 (7.5)	7.5 (10)	11 (15)	15 (20)	18.5 (25)	22 (30)	30 (40)	37 (50)	45 (60)
Input/ Output Rating	Rated Input Current (A) <2>	10	13	19	25	31	36	47	59	70
	Rated Input Capacity (kVA) <3>	9	12	17	22	28	33	43	54	64
	Rated Output Current (A) <4> <5>	11	14	21	27	34	40	52	65	77
	Overload Tolerance	Rating: 120% of rated output current for 60 s (Derating may be required for applications that start and stop frequently)								
	Carrier Frequency	4 kHz (User adjustable up to 10 kHz. Derating may be required.)								
	Maximum Output Voltage (V)	Proportional to input voltage <6>								
	Maximum Output Frequency (Hz)	400 Hz (User-adjustable)								
Power Supply	Rated Voltage Rated Frequency	Three-phase 4A□□□□ 380 to 500 Vac 50/60 Hz								
	Allowable Voltage Fluctuation	-15 to 10%								
	Allowable Frequency Fluctuation	±3% (Frequency fluctuation rate: 1 Hz/100 ms or less)								
	Allowable Phase Power Supply Voltage Unbalance	2% or less								
Harmonic Current Distortion <6>		5% or less (IEEE519 compliant)								
Input Power Factor		0.98 or more (During rated operation)								

<1> The motor capacity (HP) refers to an NEC 4-pole motor. The rated output current of the drive should be equal to or greater than the motor current. Select the appropriate capacity drive if operating the motor continuously above motor nameplate current.

<2> Assumes operation at the rated output current. Input current rating varies depending on the power supply transformer, input reactor, wiring connections, and power supply impedance.

<3> Rated input capacity is calculated with a power line voltage of $480\text{ V} \times 1.1$.

<4> The rated output current of the drive should be equal to or greater than the motor rated current.

<5> Carrier frequency is set to 4 kHz. Current derating is required to raise the carrier frequency.

<6> Commercial power mode results in near zero input harmonics. Existing power conditions and operation mode can affect input harmonics.

◆ Three-Phase 400 V Class Drive Models 4□0096 to 4□0414

Table A.4 Power Ratings (Three-Phase 400 V Class) Continued

Item		Specification								
Drive Model		4□0096	4□0124	4□0156	4□0180	4□0216	4□0240	4□0302	4□0361	4□0414
Maximum Applicable Motor Capacity kW (HP) <1>		55 (75)	75 (100)	90 (125)	110 (150)	132 (175)	150 (200)	185 (250)	220 (300)	260 (350)
Input/ Output Rating	Rated Input Current (A) <2>	87	113	142	164	197	218	275	329	377
	Rated Input Capacity (kVA) <3>	80	103	130	150	180	200	251	300	344
	Rated Output Current (A) <4> <5>	96	124	156	180	216	240	302	361	414
	Overload Tolerance	Rating: 120% of rated output current for 60 s (Derating may be required for applications that start and stop frequently)								
	Carrier Frequency	4 kHz (User adjustable up to 8 kHz. Derating may be required.)		4 kHz (User adjustable up to 6 kHz. Derating may be required.)		4 kHz				
	Maximum Output Voltage (V)	Proportional to input voltage <6>								
	Maximum Output Frequency (Hz)	400 Hz (User-adjustable)								
Power Supply	Rated Voltage Rated Frequency	Three-phase 4A□□□□ 380 to 500 Vac 50/60 Hz								
	Allowable Voltage Fluctuation	-15 to 10%								
	Allowable Frequency Fluctuation	±3% (Frequency fluctuation rate: 1 Hz/100 ms or less)								
	Allowable Phase Power Supply Voltage Unbalance	2% or less								
Harmonic Current Distortion <6>		5% or less (IEEE519 compliant)								
Input Power Factor		0.98 or more (During rated operation)								

- <1> The motor capacity (HP) refers to an NEC 4-pole motor. The rated output current of the drive should be equal to or greater than the motor current. Select the appropriate capacity drive if operating the motor continuously above motor nameplate current.
- <2> Assumes operation at the rated output current. Input current rating varies depending on the power supply transformer, input reactor, wiring connections, and power supply impedance.
- <3> Rated input capacity is calculated with a power line voltage of $480\text{ V} \times 1.1$.
- <4> The rated output current of the drive should be equal to or greater than the motor rated current.
- <5> Carrier frequency is set to 4 kHz. Current derating is required to raise the carrier frequency.
- <6> Commercial power mode results in near zero input harmonics. Existing power conditions and operation mode can affect input harmonics.

◆ Three-Phase 400 V Class Drive Models 4□0477 to 4□0930

Table A.5 Power Ratings (Three-Phase 400 V Class) Continued

Item		Specification			
Drive Model		4□0477	4□0590	4□0720	4□0930
Maximum Applicable Motor Capacity kW (HP) <1>		300 (400)	375 (500)	450 (600)	580 (800)
Input/ Output Rating	Rated Input Current (A) <2>	434	537	655	846
	Rated Input Capacity (kVA) <3>	396	490	598	773
	Rated Output Current (A) <4>	477	590	720	930
	Overload Tolerance	Rating: 120% of rated output current for 60 s (Derating may be required for applications that start and stop frequently)			
	Carrier Frequency	3 kHz			
	Maximum Output Voltage (V)	Proportional to input voltage <5>			
	Maximum Output Frequency (Hz)	400 Hz (User-adjustable)			
Power Supply	Rated Voltage Rated Frequency	380 to 500 Vac 50/60 Hz			
	Allowable Voltage Fluctuation	-15 to 10%			
	Allowable Frequency Fluctuation	±3% (Frequency fluctuation rate: 1 Hz/100 ms or less)			
	Allowable Phase Power Supply Voltage Unbalance	2% or less			
Harmonic Current Distortion <5>		5% or less (IEEE519 compliant)			
Input Power Factor		0.98 or more (During rated operation)			

<1> The motor capacity (HP) refers to an NEC 4-pole motor. The rated output current of the drive should be equal to or greater than the motor current. Select the appropriate capacity drive if operating the motor continuously above motor nameplate current.

<2> Assumes operation at the rated output current. Input current rating varies depending on the power supply transformer, input reactor, wiring connections, and power supply impedance.

<3> Rated input capacity is calculated with a power line voltage of 480 V × 1.1.

<4> The rated output current of the drive should be equal to or greater than the motor rated current.

<5> Commercial power mode results in near zero input harmonics. Existing power conditions and operation mode can affect input harmonics.

A.2 Drive Specifications

- Note:**
1. Perform rotational Auto-Tuning to obtain the performance specifications given below.
 2. For optimum performance life of the drive, install the drive in an environment that meets the required specifications.

	Item	Specification
Control Characteristics	Control Method	The following control methods can be set using drive parameters: <ul style="list-style-type: none"> • V/f Control (V/f) • Open Loop Vector Control (OLV)
	Frequency Control Range	0.01 to 400 Hz
	Frequency Accuracy (Temperature Fluctuation)	Digital input: within ±0.01% of the maximum output frequency (-10 to +40 °C) Analog input: within ±0.1% of the maximum output frequency (25 °C ±10 °C)
	Frequency Setting Resolution	Digital inputs: 0.01 Hz Analog inputs: 1/2048 of the maximum output frequency setting (11 bit plus sign)
	Output Frequency Resolution	0.001 Hz
	Frequency Setting Signal	Main speed frequency reference: DC -10 to +10 V (20 kΩ), DC 0 to +10 V (20 kΩ), 4 to 20 mA (250 Ω), 0 to 20 mA (250 Ω) Main speed reference: Pulse train input (maximum 32 kHz)
	Starting Torque	V/f: 150% at 3 Hz OLV: 200% at 0.3 Hz <1>
	Speed Control Range	V/f: 1:40 OLV: 1:200
	Speed Control Accuracy	OLV: ±0.2% (25 °C ±10 °C (77 °F ±50 °F)) <2>
	Speed Response	OLV: 10 Hz (25 °C ±10 °C (77 °F ±50 °F))
	Torque Limit	Parameters setting allow separate limits in four quadrants (available in OLV)
	Accel/Decel Time	0.0 to 6000.0 s (4 selectable combinations of independent acceleration and deceleration settings)
	Braking Torque	Same value as overload tolerance in motoring or regeneration.
	V/f Characteristics	User-selected programs and V/f preset patterns possible
	Protection Functions	Main Control Functions
Power Supply Regeneration		Available
Motor Protection		Electronic thermal overload relay
Momentary Overcurrent Protection		Drive stops when output current reaches about 200% of the rated current.
Overload Protection		Overload protection may be triggered when operating with 150% of the rated output current if the output frequency is less than 6 Hz.
Overvoltage Protection		200 V class: Stops when input voltage exceeds approximately 315 V 400 V class: Stops when input voltage exceeds approximately 630 V
Undervoltage Protection		200 V class: Stops when input voltage falls below approximately 150 V 400 V class: Stops when input voltage falls below approximately 300 V
Momentary Motor Power Ride-Thru During Utility Power Loss		2 ms or longer at full load <3>
Momentary Control Power Ride-Thru During Utility Power Loss		Typically 2 seconds or longer
Heatsink Overheat Protection		Thermistor
Stall Prevention		Stall Prevention is available during acceleration, deceleration, and during run.
Ground Protection		Electronic circuit protection <4>
Charge LED of Capacitor for Control Power Supply		Remains lit until control power supply voltage falls below 50 V

A.2 Drive Specifications

Item		Specification
Environment	Area of Use	Indoors
	Ambient Temperature	IP00 enclosure: -10 °C to +50 °C (14 °F to 122 °F) IP20/NEMA 1, UL Type 1 enclosure: -10 °C to +40 °C (14 °F to 104 °F) <7>
	Humidity	95 RH% or less (no condensation)
	Storage Temperature	-20 °C to +60 °C (short-term temperature during transportation)
	Altitude	Up to 1000 meters without derating, up to 3000 m with output current and voltage derating.
	Vibration/Shock	10 to 20 Hz: 9.8 m/s ² (2□0028 to 2□0248 and 4□0011 to 4□0414) 10 to 20 Hz: 5.9 m/s ² (4□0477 and 4□0930) 20 to 55 Hz: 5.9 m/s ² (2□0028 to 2□0081 and 4□0011 to 4□0077) 20 to 55 Hz: 2.0 m/s ² (2□0104 to 2□0248 and 4□0096 to 4□0930)
	Standards	<ul style="list-style-type: none"> • UL 61800-5-1 • IEC/EN 61800-3, IEC/EN 61800-5-1 • EN ISO 13849-1 Cat.3 PL_e, IEC/EN 61508 SIL3
	Protection Design	IP00/Open Type enclosure IP20/NEMA 1, UL Type 1 enclosure <7>

- <1> Current derating is required. Select control modes in accordance with drive capacity.
- <2> The accuracy of these values depends on motor characteristics, ambient conditions, and drive settings. Specifications may vary with different motors and with changing motor temperature. Contact Yaskawa for consultation.
- <3> Momentary motor power ride-thru during utility power loss designates the time the drive is able to maintain control over a motor operating at full load after utility power is lost. Actual specifications may vary depending on motor characteristics.
- <4> Ground protection is triggered when a ground short circuit occurs while the drive is running. The ground protection cannot be provided when the impedance of the ground fault path is too low, or when the drive is powered up while a ground fault is present at the output.
- <7> An IP20/NEMA 1, UL Type 1 enclosure drive requires an IP20/NEMA 1, UL Type 1 kit. Models 4□0720 to 4□0930 are not compatible with IP20/NEMA 1, UL Type 1 enclosures.

A.3 Drive Watt Loss Data

◆ Drive Models 2□0028 to 2□0248

Table A.6 Watt Loss 200 V Class Three-Phase Models

Drive Model	Rated Amps (A)	Heatsink Loss (W)	Interior Unit Loss (W)	Total Loss (W)
2□0028	28	659	103	762
2□0042	42	854	168	1022
2□0054	54	1037	195	1232
2□0068	68	1295	225	1520
2□0081	81	1420	238	1658
2□0104	104	1696	282	1978
2□0130	130	2157	341	2498
2□0154	154	2441	366	2807
2□0192	192	3064	447	3511
2□0248	248	3785	578	4363

◆ Drive Models 4□0011 to 4□0930

Table A.7 Watt Loss 400 V Class Three-Phase Models

Drive Model	Rated Amps (A)	Heatsink Loss (W)	Interior Unit Loss (W)	Total Loss (W)
4□0011	11	452	80	532
4□0014	14	459	79	538
4□0021	21	641	105	746
4□0027	27	675	106	781
4□0034	34	798	124	922
4□0040	40	877	174	1051
4□0052	52	1109	209	1318
4□0065	65	1369	240	1609
4□0077	77	1479	251	1730
4□0096	96	1715	290	2005
4□0124	124	2256	362	2618
4□0156	156	2857	421	3278
4□0180	180	3316	482	3798
4□0216	216	3720	587	4307
4□0240	240	3897	600	4497
4□0302	302	5202	857	6059
4□0361	361	5434	863	6297
4□0414	414	6444	1012	7456
4□0477	477	7163	1115	8279
4□0590	590	9071	1349	10421
4□0720	720	7602	1581	9183
4□0930	930	9986	2059	12045

◆ Harmonic Filter Modules for Drive Models 4□0720 to 4□0930

Table A.8 Harmonic Filter Module Watt Loss

Drive Model	Rated Amps (A)	Heatsink Loss (W)	Interior Unit Loss (W)	Total Loss (W)
EUJ71180□.□	720	3268	27	3295
EUJ71182□.□	930	4149	27	4176

A.4 Drive Derating Data

The drive can be operated at above the rated temperature, altitude, and default carrier frequency by derating the drive capacity.

◆ Rated Current Depending on Carrier Frequency

The table below shows the drive output current depending on the carrier frequency settings.

Use the data in the following tables to linearly calculate output current values for carrier frequencies not listed.

Table A.9 Three-Phase 200 V Class Carrier Frequency and Current Derating

Drive Model	Setting Range	Rated Current [A]			
		4 kHz	6 kHz	8 kHz	10 kHz
2□0028	4 to 10 kHz	28	25	22	20
2□0042	4 to 10 kHz	42	38	34	29
2□0054	4 to 10 kHz	54	49	43	38
2□0068	4 to 10 kHz	68	61	54	48
2□0081	4 to 10 kHz	81	73	65	57
2□0104	4 to 8 kHz	104	94	83	—
2□0130	4 to 8 kHz	130	117	104	—
2□0154	4 to 6 kHz	154	139	—	—
2□0192	4 to 6 kHz	192	173	—	—
2□0248	4 kHz	248	—	—	—

Table A.10 Three-Phase 400 V Class Carrier Frequency and Current Derating

Drive Model	Setting Range	Rated Current [A]			
		4 kHz	6 kHz	8 kHz	10 kHz
4□0011	4 to 10 kHz	11	9.9	8.8	7.7
4□0014	4 to 10 kHz	14	13	11	9.8
4□0021	4 to 10 kHz	21	19	17	15
4□0027	4 to 10 kHz	27	24	22	19
4□0034	4 to 10 kHz	34	31	27	24
4□0040	4 to 10 kHz	40	36	32	28
4□0052	4 to 10 kHz	52	47	42	36
4□0065	4 to 10 kHz	65	59	52	46
4□0077	4 to 10 kHz	77	69	62	54
4□0096	4 to 8 kHz	96	86	77	—
4□0124	4 to 8 kHz	124	112	99	—
4□0156	4 to 6 kHz	156	140	—	—
4□0180	4 to 6 kHz	180	162	—	—
4□0216	4 kHz	216	—	—	—
4□0240	4 kHz	240	—	—	—
4□0302	4 kHz	302	—	—	—
4□0361	4 kHz	361	—	—	—
4□0414	4 kHz	414	—	—	—
4□0477	3 kHz	477	—	—	—
4□0590	3 kHz	590	—	—	—
4□0720	3 kHz	720	—	—	—
4□0930	3 kHz	930	—	—	—

◆ Carrier Frequency Derating

Derate the drive according to [Figure A.1](#) as the carrier frequency increases above the factory default setting.

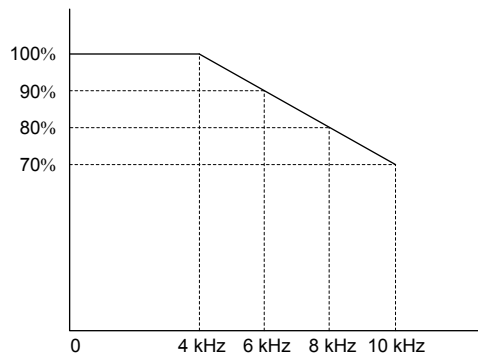

Figure A.1 Carrier Frequency Derating

◆ Temperature Derating

To ensure the maximum performance life, the drive output current must be derated as shown in [Figure A.2](#) when the drive is installed in areas with high ambient temperature. Set parameters L8-12 and L8-35 according to the installation conditions to ensure reliable drive overload protection.

■ Parameter Settings

No.	Name	Description	Range	Default
L8-12	Ambient Temperature Setting	Adjust the drive overload (oL2) protection level when the drive is installed in an environment that exceeds its ambient temperature rating.	-10 to +50	+40 °C
L8-35	Installation Method Selection	0: IP00/Open-Chassis Enclosure 2: IP20/UL Type 1 Enclosure 3: External Heatsink Installation	0, 2, 3	Det. by o2-04

Setting 0: IP00/Open-Chassis Enclosure

Drive operation between -10 °C and +50 °C allows 100% continuous current without derating.

Setting 2: IP20/UL Type 1 Enclosure

Drive operation between -10 °C and +40 °C allows 100% continuous current without derating. Operation between +40 °C and +50 °C requires output current derating.

Setting 3: External Heatsink Installation

Drive operation between -10 °C and +40 °C allows 100% continuous current without derating. Operation between +40 °C and +50 °C requires output current derating.

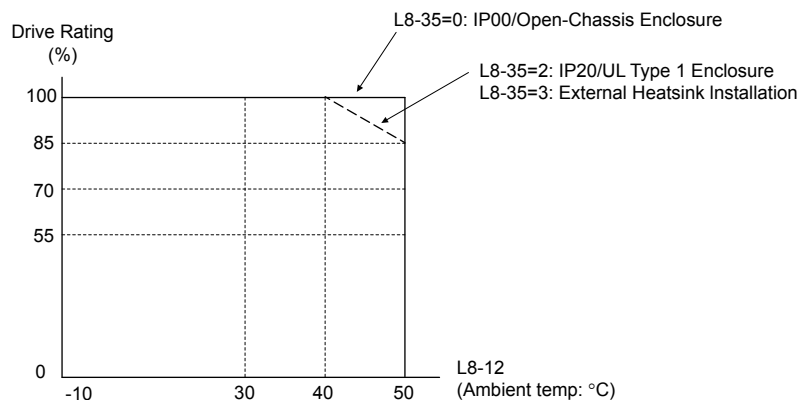

Figure A.2 Ambient Temperature and Installation Method Derating

◆ Altitude Derating

The drive standard ratings are valid for installation altitudes up to 1000 m. For installations from 1000 m to 3000 m, the drive rated voltage and the rated output current must be derated for 1% per 100 m.

This Page Intentionally Blank

Appendix: B

Parameter List

This appendix contains a full listing of all parameters and settings available in the drive.

B.1	UNDERSTANDING PARAMETER DESCRIPTIONS.....	320
B.2	A: INITIALIZATION PARAMETERS	321
B.3	B: APPLICATION.....	323
B.4	C: TUNING.....	330
B.5	D: REFERENCE SETTINGS.....	333
B.6	E: MOTOR PARAMETERS.....	336
B.7	F: OPTION SETTINGS.....	338
B.8	H PARAMETERS: MULTI-FUNCTION TERMINALS.....	344
B.9	L: PROTECTION FUNCTION.....	358
B.10	N: SPECIAL ADJUSTMENTS.....	365
B.11	O: OPERATOR-RELATED SETTINGS.....	366
B.12	P: PUMP PARAMETERS.....	369
B.13	Q: PID CONTROLLER PARAMETERS.....	384
B.14	S: SPECIAL APPLICATION.....	392
B.15	T: MOTOR TUNING.....	396
B.16	U: MONITORS.....	397
B.17	PARAMETER DEFAULT VALUES CHANGED BY CONTROL MODE.....	408
B.18	V/F PATTERN DEFAULT VALUES.....	409
B.19	DEFAULTS BY DRIVE MODEL	410

B.1 Understanding Parameter Descriptions



◆ Control Modes, Symbols, and Terms

The table below lists symbols used in this section.

All parameters in the following tables are available in V/f control mode unless specifically noted.

Note: Refer to [Control Mode Selection on page 23](#) for detailed instructions on each control mode.



Table B.1 Symbols and Icons Used in Parameter Descriptions

Symbol	Description
	Parameter is ONLY available when operating the drive with Open Loop Vector.
	Parameter can be changed during run.

B.2 A: Initialization Parameters

The A parameter group creates the operating environment for the drive. This includes the parameter Access Level, Motor Control Method, Password, User Parameters and more.

◆ A1: Initialization

No. (Addr. Hex)	Name	LCD Display	Description	Values	Page
A1-00 (0100)  </>	Language Selection	Select Language 0: English 1: ニホンゴ (Japanese) 2: Deutsch 3: Français 4: Italiano 5: Español 6: Português 7: 中文	0: English 1: Japanese 2: German 3: French 4: Italian 5: Spanish 6: Portuguese 7: Chinese	Default: 0 Range: 0 to 7	–
A1-01 (0101)  <2>	Access Level Selection	Access Level 0: Operation Only 1: User Parameters 2: Advanced Level 3: Lock Parameters	0: View and set A1-01 and A1-04. U□-□□ parameters can also be viewed. 1: User Parameters (access to a set of parameters selected by the user, A2-01 to A2-32) 2: Advanced Access (access to view and set all parameters) 3: Lock Parameters	Default: 2 Range: 0 to 3	–
A1-02 (0102) </>	Control Method Selection	Control Method 0: V/f Control 2: Open Loop Vector	0: V/f Control 2: Open Loop Vector Control	Default: 0 Range: 0, 2	–
A1-03 (0103)	Initialize Parameters	Init Parameters 0: No Initialize 1110: User Initialize 2220: 2-Wire Initial 3330: 3-Wire Initial 5550: Term->Cntrl Int 6008: Pressure Control 6009: Pump down level 6011: VTC Pressure Ctl 6012: Pivot Panel VTC 6013: Adv PressureCtrl 6014: Pivot Panel Sub 7770: General purpose 7771: Sub Mtr GP Oper	0: No initialization 1110: User Initialize (parameter values must be stored using parameter o2-03) 2220: 2-Wire initialization 3330: 3-Wire initialization 5550: Terminal->Control Initialize 6008: Pressure Control 6009: Pump Down Level 6011: VTC Pressure Control 6012: Pivot Panel VTC 6013: Advanced Pressure Control 6014: Pivot Panel Submersible 7770: General Purpose 7771: Submersible Motor General Purpose	Default: 0 Range: 0 to 5550; 6008 to 6014; 7770, 7771	163
A1-04 (0104)	Password	Enter Password	When the value set into A1-04 does not match the value set into A1-05, parameters A1-01 through A1-03, A1-06, A1-07, and A2-01 through A2-32 cannot be changed.	Default: 0000 Min.: 0000 Max.: 9999	–
A1-05 (0105)	Password Setting	Select Password	When the value set into A1-04 does not match the value set into A1-05, parameters A1-01 through A1-03, A1-06, A1-07, and A2-01 through A2-32 cannot be changed.	Default: 0000 Min.: 0000 Max.: 9999	–
A1-06 (0127)	Application Preset	Application Sel 0: Pressure Control 1: General Purpose 2: Sub Mtr GP Oper 5: General Ext HOA 6: General HOA Keys 8: Pressure Control 9: Pump Down Level 11: VTC Pressure Ctl 12: Pivot Panel VTC 13: Adv PressureCtrl 14: Pivot Panel Sub	Note: This parameter is not settable. It is used as a monitor only. 0: Pressure Control 1: General Purpose 2: Submersible Motor General Operation 5: General Ext HOA 6: General HOA Keys 8: Pressure Control 9: Pump Down Level 11: VTC Pressure Control 12: Pivot Panel VTC 13: Advanced Pressure Control 14: Pivot Panel Sub	Default: 0 Range: 0 to 2; 5, 6; 8 to 14	–

B.2 A: Initialization Parameters

No. (Addr. Hex)	Name	LCD Display	Description	Values	Page
A1-08 (0F00)	Custom Initialize Modes	Custom InitModes 0: No Initialize 3005: General Ext HOA 3006: General HOA Keys	0: No Initialization 3005: General Ext HOA 3006: General HOA Keys	Default: 0 Range: 0, 3005, 3006	165

<1> Parameter setting value is not reset to the default value when the drive is initialized.

<2> Default setting value is determined by the Application Preset selected in parameter A1-06.

◆ A2: User Parameters

No. (Addr. Hex)	Name	LCD Display	Description	Values	Page
A2-01 to A2-32 (0106 to 0125)	User Parameters 1 to 32	User Param 1 - 32	Recently edited parameters are listed here. The user can also select parameters to appear here for quicker access.	Default: <1> Range: b1-01 to S6-07	–
A2-33 (0126)	User Parameter Automatic Selection	User Parm Sel 0: Disabled 1: Enabled	0: Parameters A2-01 to A2-32 are reserved for the user to create a list of User Parameters. 1: Save history of recently viewed parameters. Recently edited parameters will be saved to A2-17 through A2-32 for quicker access.	Default: 0 Range: 0, 1	–

<1> Default setting value is determined by the Application Preset selected in parameter A1-06.

B.3 b: Application

Application parameters configure the source of the Run command, DC Injection Braking, Speed Search, timer functions, PID control, the Dwell function, Energy Savings, and a variety of other application-related settings.

◆ b1: Operation Mode Selection

No. (Addr. Hex)	Name	LCD Display	Description	Values	Page
b1-01 (0180)	Frequency Reference Selection 1	Ref Source 1 0: Operator 1: Analog Input 2: Serial Com 3: Option PCB 4: Pulse Input	0: Operator (will also switch PID setpoint to Q1-01) 1: Analog input terminals 2: MEMOBUS/Modbus communications 3: Option PCB 4: Pulse train input (terminal RP)	Default: 0 Range: 0 to 4	167
b1-02 (0181)	Run Command Selection 1	Run Source 1 0: Operator 1: Digital Inputs 2: Communication 3: Option PCB 6: AUTOKey + Term 7: AUTOKey + Serial 8: AUTOKey + Option	0: Digital operator 1: Digital input terminals 2: MEMOBUS/Modbus communications 3: Option PCB 6: AUTOKey + Term 7: AUTOKey + Serial 8: AUTOKey + Option	Default: 0 Range: 0 to 3; 6 to 8	170
b1-03 (0182)	Stopping Method Selection	Stopping Method 0: Ramp to Stop 1: Coast to Stop 2: DCInj to Stop 3: Coast w/Timer	0: Ramp to stop 1: Coast to stop 2: DC Injection Braking to stop 3: Coast with timer	Default: 1 Range: 0 to 3	171
b1-04 (0183)	Reverse Operation Selection	Reverse Oper 0: Reverse Enabled 1: Reverse Disabled	0: Reverse enabled. 1: Reverse disabled.	Default: 1 Range: 0, 1	–
b1-07 (0186)	Run Command Retention when Source is Changed	RunCmd@SrcChange 0: Require Cycle 1: Retain Run Cmd	Determines whether the run command is retained when the Sequence Selection is changed 0: Require Cycle 1: Retain Run Command	Default: 0 Range: 0, 1	–
b1-08 (0187)	Run Command Selection in Programming Mode	RUN dur PRG Mode 0: Run Disabled@PRG 1: Run Enabled@PRG 2: Prg only @ Stop	0: Run command is not accepted while in Programming Mode. 1: Run command is accepted while in Programming Mode. 2: Prohibit entering Programming Mode during run.	Default: 0 Range: 0 to 2	–
b1-11 (01DF)	Run Delay at Stop (Back Spin Timer)	Run Delay @ Stop	Sets the amount of time that the drive will disallow the reapplication of the Run command after the Run command is lost. b1-11 is active for all b1-03 settings. If set to zero and b1-03 = 3 (Coast to Stop w/ Timer), a combination of C1-02 and output frequency determine the length of time. Otherwise, no run delay will be applied.	Default: 0.0 s Min.: 0.0 Max.: 6000.0	–
b1-12 (01E0)	Run Delay Memory Selection	Run Dly Mem Sel	Determines whether the Run Delay Timer is saved to the EEPROM during power loss. 0: Disabled 1: Only at Stop 2: Running & Stop Note: A JVOP-183 HOA Keypad must be plugged into the drive for settings 1 and 2 to function. If the keypad is removed, b1-12 will function as setting 0 (Disabled).	Default: 2 Range: 0 to 2	–
b1-14 (01C3)	Phase Order Selection	Rotation Sel 0: Standard 1: SwitchPhaseOrder	0: Standard 1: Switch phase order (reverses the direction of the motor)	Default: 0 Range: 0, 1	–
b1-15 (01C4)	Frequency Reference Selection 2	Ref Source 2 0: Operator 1: Analog Input 2: Serial Com 3: Option PCB 4: Pulse Input	Enabled when an input terminal set for “External reference” (H1-□□ = 2) closes. 0: Digital operator 1: Terminals (analog input terminals) 2: MEMOBUS/Modbus communications 3: Option card 4: Pulse train input	Default: 0 Range: 0 to 4	–

B.3 b: Application

No. (Addr. Hex)	Name	LCD Display	Description	Values	Page
b1-16 (01C5)	Run Command Selection 2	Run Source 2 0: Operator 1: Digital Inputs 2: Communication 3: Option PCB 6: AUTOKey + Term 7: AUTOKey + Serial 8: AUTOKey + Option	Enabled when a terminal set for “External reference” (H1-□□ = 2) closes. 0: Digital operator 1: Digital input terminals 2: MEMOBUS/Modbus communications 3: Option card 6: AUTOKey + Term 7: AUTOKey + Serial 8: AUTOKey + Option	Default: 0 Range: 0 to 3; 6 to 8	–
b1-17 (01C6)	Run Command at Power Up	Run Cmd @ Pwr On 0: Cycle Ext Run 1: Accept Ext Run	0: Disregarded. A new Run command must be issued after power up. 1: Allowed. Motor will start immediately after power up if a Run command is already enabled.	Default: 1 Range: 0, 1	–
b1-24 (0B2C)	Commercial Power Operation Switching Selection	CommerclPwrSwSel 0: Disabled 1: Enabled	0: Disabled 1: Enabled	Default: 0 Range: 0, 1	–
b1-25 (0B2D)	Commercial Power Supply Operation Cancellation Level	Freq Deviate Lvl	Sets the judgement value of the hysteresis comparator in the judgment section for the commercial power switching function in increments of 0.1 Hz.	Default: 1.0 kHz Min.: 0.4 Max.: 6.0	–
b1-26 (0B2E)	Commercial Power Supply Operation Switching Level	Freq Accept Lvl		Default: 0.2 kHz Min.: 3.0 Max.: 6.0	–

◆ b2: DC Injection Braking

No. (Addr. Hex)	Name	LCD Display	Description	Values	Page
b2-01 (0189)	DC Injection Braking Start Frequency	DCInj Start Freq	Sets the frequency at which DC Injection Braking starts when “Ramp to stop” (b1-03 = 0) is selected.	Default: 0.5 Hz Min.: 0.0 Max.: 10.0	–
b2-02 (018A)	DC Injection Braking Current	DCInj Current	Sets the DC Injection Braking current as a percentage of the drive rated current.	Default: 50% Min.: 0 Max.: 100	–
b2-03 (018B)	DC Injection Braking Time at Start	DCInj Time@Start	Sets DC Injection Braking time at start. Disabled when set to 0.00 seconds.	Default: 0.00 s Min.: 0.00 Max.: 10.00	–
b2-04 (018C)	DC Injection Braking Time at Stop	DCInj Time@Stop	Sets DC Injection Braking time at stop.	Default: 0.50 s Min.: 0.00 Max.: 10.00	–
b2-08 (0190)	Magnetic Flux Compensation Value	Field Comp	OLV Sets the magnetic flux compensation as a percentage of the no-load current value (E2-03).	Default: 0% Min.: 0 Max.: 1000	–

◆ b3: Speed Search

No. (Addr. Hex.)	Name	LCD Display	Description	Values	Page
b3-01 (0191)	Speed Search Selection at Start	SpdSrch at Start 0: Disabled 1: Enabled	0: Disabled 1: Enabled	Default: 0 Range: 0, 1	172
b3-03 (0193)	Speed Search Deceleration Time	SpdSrch Dec Time	Sets output frequency reduction time during Speed Search.	Default: 2.0 s Min.: 0.1 Max.: 10.0	–
b3-04 (0194)	V/f Gain during Speed Search (Speed Estimation Type)	SpdSrch V/f	Determines how much to lower the V/f ratio during Speed Search. Output voltage during Speed Search equals the V/f setting multiplied by b3-04.	Default: <I> Min.: 10% Max.: 100%	–
b3-05 (0195)	Speed Search Delay Time	Search Delay	When using an external contactor on the output side, b3-05 delays executing Speed Search after a momentary power loss to allow time for the contactor to close.	Default: 0.2 s Min.: 0.0 Max.: 100.0	–

No. (Addr Hex.)	Name	LCD Display	Description	Values	Page
b3-06 (0196)	Output Current 1 during Speed Search (Speed Estimation Type)	Srch Im Lvl1	Sets the current injected to the motor at the beginning of Speed Estimation Speed Search. Set as a coefficient for the motor rated current.	Default: <1> Min.: 0.0 Max.: 2.0	–
b3-08 (0198)	Current Control Gain during Speed Search (Speed Estimation Type)	Srch ACR P Gain	Sets the proportional gain for the current controller during Speed Search. There is normally no need to change this parameter from the default setting.	Default: <2> Min.: 0.00 Max.: 6.00	–
b3-10 (019A)	Speed Search Detection Compensation Gain (Speed Estimation Type)	Srch Detect Comp	Sets the gain which is applied to the speed detected by Speed Estimation Speed Search before the motor is reaccelerated. Increase this setting if ov occurs when performing Speed Search after a relatively long period of baseblock.	Default: 1.05 Min.: 1.00 Max.: 1.20	–
b3-17 (01F0)	Speed Search Restart Current Level (Speed Estimation Type)	SrchRestart Lvl	Sets the Speed Search restart current level as a percentage of the drive rated current.	Default: 150% Min.: 0 Max.: 200	–
b3-18 (01F1)	Speed Search Restart Detection Time (Speed Estimation Type)	SrchRestart Time	Sets the time to detect Speed Search restart.	Default: 0.10 s Min.: 0.00 Max.: 1.00	–
b3-19 (01F2)	Number of Speed Search Restarts (Speed Estimation Type)	Num of SrchRestr	Sets the number of times the drive can attempt to restart when performing Speed Search.	Default: 3 Min.: 0 Max.: 10	–
b3-24 (01C0)	Speed Search Method Selection	SpdSrch Method 1: CurrentDetection 2: Speed Estimation 3: Speed Estimation2 4: CurrentDetection3	1: Current Detection 2: Speed Estimation 3: Speed Estimation 2 4: Current Detection 3	Default: <2> Range: <2>	–
b3-25 (01C8)	Speed Search Wait Time (Speed Estimation Type)	SpdSrch WaitTime	Sets the time the drive must wait between each Speed Search restart attempt.	Default: 0.5 s Min.: 0.0 Max.: 30.0	–
b3-27 (01C9)	Start Speed Search Select	SPD Search By AI 0: start from 0 1: start SPD	Selects a condition to activate Speed Search Selection at Start (b3-01) or External Speed Search Command 1 or 2 from the multi-function input. 0: Triggered when a Run command is issued (normal). 1: Triggered when an external baseblock is released.	Default: 0 Range: 0, 1	–
b3-31 (0BC0)	Speed Search Operation Current Level 1 (Current Detection 1)	Search (I2) Lvl1	Set the current level to use to limit the output current during a Speed Search.	Default: 1.50 Min.: 1.50 Max.: 3.50	–
b3-32 (0BC1)	Speed Search Operation Current Level 2 (Current Detection 2)	Search (I2) Lvl2	Set the current level at which to end the Speed Search for Current Detection Type Speed Search 2.	Default: 1.20 Min.: 0.00 Max.: 1.49	–
b3-33 (0B3F)	Speed Search Selection when Run Command is Given during Uv	SpdSrch Start UV 0: Disabled 1: Enabled	Activates and deactivates Speed Search at start in accordance with whether a Run command was issued during an undervoltage (Uv) condition. Function is active when a momentary power loss (L2-01 = 1 or 2), Speed Search at start (b3-01 = 1), and coasting to a stop (b1-03 = 1) are enabled. 0: Disabled 1: Enabled	Default: 0 Range: 0, 1	–
b3-50 (0BC7)	Backspin Search Direction Judgment Time 1	Bkspin Srch Time1	Adjusts the direction of Speed Search to allow for backspin.	Default: 0.0 s Min.: 0.0 Max.: 10.0	–
b3-51 (0BC8)	Backspin Search Direction Judgment Time 2	Bkspin Srch Time2		Default: 0.0 s Min.: 0.0 Max.: 10.0	–
b3-52 (0BC9)	Backspin Search Deceleration Time 1	BkspinSrchDecel1	Sets the search frequency deceleration rate when searching from the direction command when the momentary power loss time is shorter than the time set in b3-50.	Default: 2.0 s Min.: 0.1 Max.: 10.0	–
b3-53 (0BCA)	Backspin Search Deceleration Time 2	BkspinSrchDecel2	Sets the search frequency deceleration rate for a Speed Search from the opposite direction of the direction command when the momentary power loss time is equal to or longer than the time set in b3-51.	Default: 2.0 s Min.: 0.1 Max.: 10.0	–

<1> Default setting is determined by parameter o2-04, Drive Model Selection.

<2> Default setting is determined by parameters A1-02, Control Method Selection, and o2-04, Drive Model Selection.

<3> Setting range is determined by o2-04, Drive Model Selection.

Range is 1, 2 in models 2□0028 to 2□0248 and 4□0011 to 4□0414.

Range is 2 to 4 in models 4□0477 to 4□0930.

◆ b4: Timer Function

No. (Addr. Hex)	Name	LCD Display	Description	Values	Page
b4-01 (01A3)	Timer Function On-Delay Time	Delay-ON Timer	Sets the on-delay and off-delay times for a digital timer output (H2-□□ = 12). The output is triggered by a digital input programmed to H1-□□ = 18).	Default: 0.0 s Min.: 0.0 Max.: 3000.0	–
b4-02 (01A4)	Timer Function Off-Delay Time	Delay-OFF Timer		Default: 0.0 s Min.: 0.0 Max.: 3000.0	–
b4-03 (0B30)	H2-01 ON Delay Time	H2-01 ON Delay	Sets the length of the delay time for contact outputs to open or close for the related functions set in H2-□□.	Default: 0 ms Min.: 0 Max.: 65000	–
b4-04 (0B31)	H2-01 OFF Delay Time	H2-01 OFF Delay			
b4-05 (0B32)	H2-02 ON Delay Time	H2-02 ON Delay			
b4-06 (0B33)	H2-02 OFF Delay Time	H2-02 OFF Delay			
b4-07 (0B34)	H2-03 ON Delay Time	H2-03 ON Delay			
b4-08 (0B35)	H2-03 OFF Delay Time	H2-03 OFF Delay			

◆ b5: PID Control

No. (Addr. Hex)	Name	LCD Display	Description	Values	Page
b5-01 (01A5)	PID Function Setting	PID Mode 0: Disabled 1: Enabled D=Fdbk	0: Disabled 1: Enabled (PID output becomes output frequency reference, deviation D controlled)	Default: 1 Range: 0, 1	–
b5-02 (01A6) <u>RUN</u>	Proportional Gain Setting (P)	PID Gain	Sets the proportional gain of the PID controller. Note: Has no effect when P1-24 > 0.	Default: 2.00 Min.: 0.00 Max.: 25.00	–
b5-03 (01A7) <u>RUN</u>	Integral Time Setting (I)	PID I Time	Sets the integral time for the PID controller.	Default: 3.0 s Min.: 0.0 Max.: 360.0	–
b5-04 (01A8) <u>RUN</u>	Integral Limit Setting	PID I Limit	Sets the maximum output possible from the integrator as a percentage of the maximum output frequency. Note: Has no effect when P1-24 > 0.	Default: 100.0% Min.: 0.0 Max.: 100.0	–
b5-05 (01A9) <u>RUN</u>	Derivative Time (D)	PID D Time	Sets D control derivative time.	Default: 0.00 s Min.: 0.00 Max.: 10.00	–
b5-06 (01AA) <u>RUN</u>	PID Output Limit	PID Limit	Sets the maximum output possible from the entire PID controller as a percentage of the maximum output frequency.	Default: 100.0% Min.: 0.0 Max.: 100.0	–
b5-07 (01AB) <u>RUN</u>	PID Offset Adjustment	PID Offset	Applies an offset to the PID controller output. Set as a percentage of the maximum output frequency.	Default: 0.0% Min.: -100.0 Max.: 100.0	–
b5-08 (01AC) <u>RUN</u>	PID Primary Delay Time Constant	PID Delay Time	Sets a low pass filter time constant on the output of the PID controller.	Default: 0.00 s Min.: 0.00 Max.: 10.00	–
b5-09 (01AD)	PID Output Level Selection	Output Level Sel 0: Normal Character 1: Rev Character	0: Direct Acting 1: Inverse Acting	Default: 0 Range: 0, 1	–
b5-10 (01AE) <u>RUN</u>	PID Output Gain Setting	Output Gain	Sets the gain applied to the PID output.	Default: 1.00 Min.: 0.00 Max.: 25.00	–

No. (Addr. Hex)	Name	LCD Display	Description	Values	Page
b5-11 (01AF)	PID Output Reverse Selection	Output Rev Sel 0: 0 limit 1: Reverse	0: Negative PID output triggers zero limit. 1: Rotation direction reverses with negative PID output. Note: When using setting 1, make sure reverse operation is permitted by b1-04.	Default: 0 Range: 0, 1	-
b5-12 (01B0)	Feedback Loss 4 to 20 mA Detection Selection	Fdbk 4-20mA Det 0: Disabled 1: Alarm Only 2: Fault 3: Run At b5-13	Performs a 4 to 20 mA wire break detection on the analog input that is programmed for PID feedback.	Default: 2 Range: 0 to 3	-
b5-13 (01B1) <u>RUN</u>	Feedback Loss Go To Frequency	FdbkLossGotoFreq	Sets the speed at which the drive will run if a 4 to 20 mA wire break is detected on the PID Feedback and when b5-12 is set to 3 (Run at b5-13).	Default: 0.0 Hz Min.: 0.0 Max.: 400.0	-
b5-14 (01B2) <u>RUN</u>	Feedback Loss of Prime Level	FdbkLoss LOP Lvl	Detects loss of prime in the pump when a wire break condition has occurred. When the measured quantity determined by P1-18 (output current, kilowatts, or power) drops below this level for the time set in P1-20 and the output frequency is at the level set in b5-13, a "Loss of Prime" condition occurs. The drive responds to the "Loss of Prime" condition depending on the setting of P1-22, Loss of Prime Selection.	Default: 0.0 A <> Min.: 0.0 Max.: 1000.0	-
b5-15 (01B3) <u>RUN</u>	Feedback Loss Go To Frequency Time Out	FdbkLossGotoTimO	When b5-12 = 3 and the Feedback signal is lost, the drive will run at the b5-13 speed for the b5-15 time, after which the drive will fault on Feedback Loss (FDBKL). Timeout is disabled when set to 0sec and the drive will run indefinitely at b5-13.	Default: 0 s Min.: 0 Max.: 6000	-
b5-16 (01B3) <u>RUN</u>	Feedback Loss Start Delay	FdbkLossStartDly	When an AUTO Run command is initiated, the drive will not fault on Feedback Loss (FDBKL) or use the Feedback Loss GoTo Frequency (b5-13) until the b5-16 time has expired.	Default: 0.0 s Min.: 0.0 Max.: 120.0	-
b5-17 (01B5)	PID Accel/Decel Time	PID Acc/Dec Time	Sets the acceleration and deceleration time to PID setpoint.	Default: 0.0 s Min.: 0.0 Max.: 6000.0	-
b5-32 (01EE) <u>RUN</u>	Integrator Ramp Limit	IntegratrRampLim	When set to a value greater than zero, the PI Integrator is forced to be within +/- this amount of the soft starter output.	Default: 0.0 Hz Min.: 0.0 Max.: 10.0	-
b5-34 (019F) <u>RUN</u>	PID Output Lower Limit	PID Out Low Lim	Sets the minimum output possible from the PID controller as a percentage of the maximum output frequency.	Default: 0.00% Min.: -100.00 Max.: 100.00	-
b5-35 (01A0) <u>RUN</u>	PID Input Limit	PID Input Limit	Limits the PID control input (deviation signal) as a percentage of the maximum output frequency. Acts as a bipolar limit.	Default: 1000.0% Min.: 0.0 Max.: 1000.0	-
b5-39 (01FF)	PID Setpoint Display Digits	PID UsrDspDigits 0: No Dec (XXXXX) 1: 1 Dec (XXXX.X) 2: 2 Dec (XXX.XX) 3: 3 Dec (XX.XXX)	0: No decimal places 1: One decimal place 2: Two decimal places 3: Three decimal places	Default: 1 Range: 0 to 3	-
b5-40 (017F)	Frequency Reference Monitor Content during PID	Fref Mon Sel@PID 0: Fref Mon w PID 1: Fref Mon w/o PID	0: Display the frequency reference (U1-01) after PID compensation has been added. 1: Display the frequency reference (U1-01) before PID compensation has been added.	Default: 0 Range: 0, 1	-
b5-41 (0160)	PI Output 2 Unit Selection	PI Out2 Unit Sel 0: No Unit 1: PSI :lb/SqrInch 2: Pa:Pascals 3: Bar:Bar 4: "WC: InchOfWater 5: "Hg:Inch Mercury 6: ft: feet 7: m: meters 8: °F:DegFarenheit 9: °C:DegCelsius 10: %: Percent 11: kPa:Kilopascal	0: No Unit 1: Pounds per square inch 2: Pascals 3: Bar 4: Inch of Water 5: Inch of Mercury 6: Feet 7: Meters 8: Degrees Fahrenheit 9: Degrees Celsius 10: Percent 11: Kilopascal	Default: 0 Range: 0 to 11	-

B.3 b: Application

No. (Addr. Hex)	Name	LCD Display	Description	Values	Page
b5-42 (0161) RUN	PI Output 2 Calculation Mode	PI Out2 Cal Mode 0: Linear 1: Square Root 2: 1/f ² 3: 1/f ³	0: Linear - the monitor displays PID output 1: Square root - the monitor displays square root PID output 2: Quadratic - the monitor displays 1/(PID output) ² 3: Cubic - the monitor displays 1/(PID output) ³ Note: Used for U5-14 and U5-15 only.	Default: 0 Range: 0 to 3	–
b5-43 (0162) RUN	PI Output 2 Monitor Max Upper 4 Digits	PI Out2 MonMax U	Sets the upper 4 digits of the maximum monitor value. Used with b5-44 to set maximum monitor value of U5-14 and U5-15 at maximum frequency. Note: Used for U5-14 and U5-15 only.	Default: 0 Min.: 0 Max.: 9999	–
b5-44 (0163) RUN	PI Output 2 Monitor Max Lower 4 Digits	PI Out2 MonMax L	Sets the lower 4 digits of the maximum monitor value. Used with b5-43 to set maximum monitor value of U5-14 and U5-15 at maximum frequency. Note: Used for U5-14 and U5-15 only.	Default: 0 Min.: 0 Max.: 99.99	–
b5-45 (0164) RUN	PI Output 2 Monitor Minimum	PI Out2 MonMin	Sets the minimum display value at zero speed. This function is effective when b5-42 is set to 0 (Linear output mode). Note: Used for U5-14 and U5-15 only.	Default: 0 Min.: 0 Max.: 999.9	–

<> Unit text is set by P1-18, Prime Loss Detection Method.

◆ b6: Dwell Function

No. (Addr. Hex)	Name	LCD Display	Description	Values	Page
b6-01 (01B6)	Dwell Reference at Start	Dwell Ref @Start	Parameters b6-01 and b6-02 set the frequency to hold and the time to maintain that frequency at start.	Default: 0.0 Hz Min.: 0.0 Max.: 400.0	–
b6-02 (01B7)	Dwell Time at Start	Dwell Time@Start		Default: 0.0 s Min.: 0.0 Max.: 10.0	–
b6-03 (01B8)	Dwell Reference at Stop	Dwell Ref @Stop	Parameters b6-03 and b6-04 set the frequency to hold and the time to maintain that frequency at stop.	Default: 0.0 Hz Min.: 0.0 Max.: 400.0	–
b6-04 (01B9)	Dwell Time at Stop	Dwell Time @Stop		Default: 0.0 s Min.: 0.0 Max.: 10.0	–

◆ b8: Energy Saving

No. (Addr. Hex)	Name	LCD Display	Description	Values	Page
b8-01 (01CC)	Energy Saving Control Selection	Energy Save Sel 0: Disabled 1: Enabled	0: Disabled 1: Enabled	Default: 0 Range: 0, 1	–
b8-02 (01CD) RUN	Energy Saving Gain	Energy Save Gain	OLV Sets the gain used for Energy Saving.	Default: </> Min.: 0.0 Max.: 10.0	–
b8-03 (01CE) RUN	Energy Saving Control Filter Time Constant	Energy Save F.T	OLV Sets a time constant for Energy Saving.	Default: <> Min.: 0.00 s Max.: 10.00 s	–
b8-04 (01CF)	Energy Saving Coefficient Value	Energy Save COEF	Determines the level of maximum motor efficiency. Setting range is 0.0 to 2000.0 for drives 3.7 kW and smaller.	Default: <> <> Min.: 0.00 Max.: 655.00	–
b8-05 (01D0)	Power Detection Filter Time	kW Filter Time	Sets a time constant filter for output power detection.	Default: 20 ms Min.: 0 Max.: 2000	–

No. (Addr. Hex)	Name	LCD Display	Description	Values	Page
b8-06 (01D1)	Search Operation Voltage Limit	Search V Limit	Sets the limit for the voltage search operation as a percentage of the motor rated voltage.	Default: 0% Min.: 0 Max.: 100	-

- <1> Default setting is determined by parameter A1-02, Control Method Selection.
- <2> Default setting is determined by parameters A1-02, Control Method Selection, and o2-04, Drive Model Selection.
- <3> Default setting is determined by parameter o2-04, Drive Model Selection.
- <4> Parameter value changes automatically if E2-11 is manually changed or changed by Auto-Tuning.

B.4 C: Tuning

C parameters are used to adjust the acceleration and deceleration times, S-curves, torque compensation, and carrier frequency selections.

◆ C1: Acceleration and Deceleration Times

No. (Addr. Hex)	Name	LCD Display	Description	Values	Page
C1-01 (0200) [RUN]	Acceleration Time 1	Accel Time 1	Sets the time to accelerate from 0 to maximum frequency.	Default: 20.0 s Min.: 0.0	174
C1-02 (0201) [RUN]	Deceleration Time 1	Decel Time 1	Sets the time to decelerate from maximum frequency to 0.	Max.: 6000.0 <I>	174
C1-03 (0202) [RUN]	Acceleration Time 2	Accel Time 2	Sets the time to accelerate from 0 to maximum frequency.	Default: 10.0 s Min.: 0.0	174
C1-04 (0203) [RUN]	Deceleration Time 2	Decel Time 2	Sets the time to decelerate from maximum frequency to 0.	Max.: 6000.0 <I>	174
C1-05 (0204) [RUN]	Acceleration Time 3	Accel Time 3	Sets the time to accelerate from 0 to maximum frequency.	Default: 10.0 s Min.: 0.0	174
C1-06 (0205) [RUN]	Deceleration Time 3	Decel Time 3	Sets the time to decelerate from maximum frequency to 0.	Max.: 6000.0 <I>	174
C1-09 (0208) [RUN]	Fast Stop Time	Fast Stop Time	Sets the time for the Fast Stop function.	Default: 10.0 s Min.: 0.0 Max.: 6000.0 <I>	–
C1-10 (0209)	Accel/Decel Time Setting Units	Acc/Dec Units 0: 0.01 Seconds 1: 0.1 Seconds	0: 0.01 s (0.00 to 600.00 s) 1: 0.1 s (0.0 to 6000.0 s)	Default: 1 Range: 0, 1	–
C1-11 (020A)	Accel/Decel Time Switching Frequency	Acc/Dec SW Freq	Sets the frequency to switch between accel/decel time settings	Default: 0.0 Hz Min.: 0.0 Max.: 400.0	–

<I> Setting range value is determined by parameter C1-10, Accel/Decel Time Setting Units. When C1-10 = 0 (units of 0.01 seconds), the setting range becomes 0.00 to 600.00 seconds.

◆ C2: S-Curve Characteristics

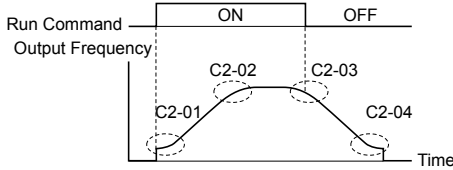
No. (Addr. Hex)	Name	LCD Display	Description	Values	Page
C2-01 (020B)	S-Curve Characteristic at Accel Start	SCrv Acc @ Start	The S-curve can be controlled at the four points shown below. 	Default: 0.20 s Min.: 0.00 Max.: 10.00	–
C2-02 (020C)	S-Curve Characteristic at Accel End	SCrv Acc @ End		Default: 0.20 s Min.: 0.00 Max.: 10.00	–
C2-03 (020D)	S-Curve Characteristic at Decel Start	SCrv Dec @ Start		Default: 0.20 s Min.: 0.00 Max.: 10.00	–
C2-04 (020E)	S-Curve Characteristic at Decel End	SCrv Dec @ End		Default: 0.00 s Min.: 0.00 Max.: 10.00	–

◆ C3: Slip Compensation

No. (Addr. Hex)	Name	LCD Display	Description	Values	Page
C3-01 (020F) <u>RUN</u>	Slip Compensation Gain	Slip Comp Gain	Sets the gain for the motor slip compensation function used for motor 1.	Default: </> Min.: 0.0 Max.: 2.5	–
C3-02 (0210) <u>RUN</u>	Slip Compensation Primary Delay Time	Slip Comp Time	Adjusts the slip compensation function delay time used for motor 1.	Default: </> Min.: 0 ms Max.: 10000 ms	–
C3-03 (0211)	Slip Compensation Limit	Slip Comp Limit	Sets an upper limit for the slip compensation function as a percentage of motor rated slip for motor 1 (E2-02).	Default: 200% Min.: 0 Max.: 250	–
C3-04 (0212)	Slip Compensation Selection during Regeneration	Slip Comp Regen	0: Disabled. 1: Enabled above 6 Hz. 2: Enabled whenever slip compensation is possible.	Default: 0 Range: 0 to 2	–
C3-05 (0213)	Output Voltage Limit Operation Selection	Output V Lim Sel	OLV 0: Disabled. 1: Enabled. Automatically decreases motor flux when output voltage saturation is reached.	Default: 0 Range: 0, 1	–

<1> Default setting is determined by parameter A1-02, Control Method Selection.

◆ C4: Torque Compensation

No. (Addr. Hex)	Name	LCD Display	Description	Values	Page
C4-01 (0215) <u>RUN</u>	Torque Compensation Gain	Torq Comp Gain	Sets the gain for the automatic torque (voltage) boost function and helps to produce better starting torque. Used for motor 1.	Default: 1.00 Min.: 0.00 Max.: 2.50	–
C4-02 (0216) <u>RUN</u>	Torque Compensation Primary Delay Time 1	Torq Comp Time	Sets the torque compensation filter time.	Default: </> Min.: 0 ms Max.: 60000 ms	–
C4-03 (0217)	Torque Compensation at Forward Start	F TorqCmp@start	OLV Sets torque compensation at forward start as a percentage of motor torque.	Default: 0.0% Min.: 0.0 Max.: 200.0	–
C4-04 (0218)	Torque Compensation at Reverse Start	R TorqCmp@start	OLV Sets torque compensation at reverse start as a percentage of motor torque.	Default: 0.0% Min.: -200.0 Max.: 0.0	–
C4-05 (0219)	Torque Compensation Time Constant	TorqCmp Delay T	OLV Sets the time constant for torque compensation at forward start and reverse start (C4-03 and C4-04).	Default: 10 ms Min.: 0 Max.: 200	–

<1> Default setting is determined by parameters A1-02, Control Method Selection, and o2-04, Drive Model Selection.

◆ C6: Carrier Frequency

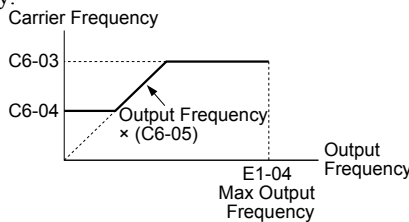
No. (Addr. Hex)	Name	LCD Display	Description	Values	Page
C6-02 (0224)	Carrier Frequency Selection	CarrierFreq Sel 0: Fc=3.0 kHz 1: Fc=4.0 kHz 2: Fc=6.0 kHz 3: Fc=8.0 kHz 4: Fc=10.0 kHz F: Program	0: 3.0 kHz 1: 4.0 kHz 2: 6.0 kHz 3: 8.0 kHz 4: 10.0 kHz F: User-defined (determined by C6-03 to C6-05)	Default: <1> Range: <2>	-
C6-03 (0225)	Carrier Frequency Upper Limit	CarrierFreq Max	Note: C6-04 and C6-05 are available only in V/f control.	Default: <3> Min.: 3.0 kHz Max.: 10.0 kHz	-
C6-04 (0226)	Carrier Frequency Lower Limit	CarrierFreq Min	Determines the upper and lower limits for the carrier frequency. In OLV, C6-03 determines the upper limit of the carrier frequency.	Default: <3> Min.: 3.0 kHz Max.: 10.0 kHz	-
C6-05 (0227)	Carrier Frequency Proportional Gain	CarrierFreq Gain	 <p>Note: Setting range of C6-04 and C6-05 is 4.0 to 10.0 kHz for models 2□0028 to 2□0248, 4□0011 to 4□0414. Setting value is only 3 kHz for models 4□0477 and 4□0930.</p>	Default: <3> Min.: 0 Max.: 99	-
C6-09 (022B)	Carrier Frequency during Rotational Auto-Tuning	Carrier in tune 0: Fc = 5kHz 1: Fc = C6-03	OLV 0: Carrier Frequency = 4 kHz. 1: Setting value for C6-03. Note: Carrier frequency is 3 kHz for models 4□0477 and 4□0930.	Default: 0 Range: 0, 1	-

- <1> Default setting value is determined by parameters A1-02, Control Method Selection and o2-04, Drive Model Selection.
- <2> Setting range is determined by o2-04, Drive Model Selection.
Range is 1 to 4 and F in models 2□0028 to 2□0248 and 4□0011 to 4□0414.
Range is 0, F in models 4□0477 and 4□0930.
- <3> Default setting value is determined by parameters C6-02, Carrier Frequency Selection, and o2-04, Drive Model Selection.
- <4> Default setting value is determined by parameter C6-02, Carrier Frequency Selection.

◆ C7: Voltage Adjustment

No. (Addr. Hex)	Name	LCD Display	Description	Values	Page
C7-43 (112A)	Input Voltage Offset Adjustment	InputVolt Offset	Adjusts the offset for the input voltage circuit when the control board is replaced. 0000: Standard 0002: Offset adjustment not required	Default: 0000 Range: 0000 to 9999	-
C7-56 (1107)	Power Factor Control Selection	PF Control Sel 0: PF Ctrl Disabled 1: PF Ctrl Enabled	0: Power factor control disabled 1: Power factor control enabled	Default: 0 Range: 0, 1	-
C7-60 (0B1C)	Output Voltage Limit Mode Selection	V Out Limit Sel 0: Limit Harmonics 1: Improve PF	0: Harmonic suppression priority mode 1: High output voltage mode	Default: 1 Range: 0, 1	-
C7-61 (0B1E)	Output Voltage Limit Level	Out V Lim Lvl	Sets the output voltage limitation level when C7-60 is set to 0.	Default: 92.0% Min.: 10.0 Max.: 100.0	-

B.5 d: Reference Settings

Reference parameters set the various frequency reference values during operation.

◆ d1: Frequency Reference

No. (Addr. Hex)	Name	LCD Display	Description	Values	Page
d1-01 (0280) 	Frequency Reference 1	Reference 1	Sets the frequency reference for the drive. Setting units are determined by parameter o1-03.	Default: 0.00 Hz Min.: 0.00 Max.: 400.00 </>	–
d1-02 (0281) 	Frequency Reference 2	Reference 2	Sets the frequency reference for the drive. Setting units are determined by parameter o1-03.	Default: 0.00 Hz Min.: 0.00 Max.: 400.00 </>	–
d1-03 (0282) 	Frequency Reference 3	Reference 3	Sets the frequency reference for the drive. Setting units are determined by parameter o1-03.	Default: 0.00 Hz Min.: 0.00 Max.: 400.00 </>	–
d1-04 (0283) 	Frequency Reference 4	Reference 4	Sets the frequency reference for the drive. Setting units are determined by parameter o1-03.	Default: 0.00 Hz Min.: 0.00 Max.: 400.00 </>	–
d1-05 (0284) 	Frequency Reference 5	Reference 5	Sets the frequency reference for the drive. Setting units are determined by parameter o1-03.	Default: 0.00 Hz Min.: 0.00 Max.: 400.00 </>	–
d1-06 (0285) 	Frequency Reference 6	Reference 6	Sets the frequency reference for the drive. Setting units are determined by parameter o1-03.	Default: 0.00 Hz Min.: 0.00 Max.: 400.00 </>	–
d1-07 (0286) 	Frequency Reference 7	Reference 7	Sets the frequency reference for the drive. Setting units are determined by parameter o1-03.	Default: 0.00 Hz Min.: 0.00 Max.: 400.00 </>	–
d1-08 (0287) 	Frequency Reference 8	Reference 8	Sets the frequency reference for the drive. Setting units are determined by parameter o1-03.	Default: 0.00 Hz Min.: 0.00 Max.: 400.00 </>	–
d1-09 (0288) 	Frequency Reference 9	Reference 9	Sets the frequency reference for the drive. Setting units are determined by parameter o1-03.	Default: 0.00 Hz Min.: 0.00 Max.: 400.00 </>	–
d1-10 (028B) 	Frequency Reference 10	Reference 10	Sets the frequency reference for the drive. Setting units are determined by parameter o1-03.	Default: 0.00 Hz Min.: 0.00 Max.: 400.00 </>	–
d1-11 (028C) 	Frequency Reference 11	Reference 11	Sets the frequency reference for the drive. Setting units are determined by parameter o1-03.	Default: 0.00 Hz Min.: 0.00 Max.: 400.00 </>	–
d1-12 (028D) 	Frequency Reference 12	Reference 12	Sets the frequency reference for the drive. Setting units are determined by parameter o1-03.	Default: 0.00 Hz Min.: 0.00 Max.: 400.00 </>	–
d1-13 (028E) 	Frequency Reference 13	Reference 13	Sets the frequency reference for the drive. Setting units are determined by parameter o1-03.	Default: 0.00 Hz Min.: 0.00 Max.: 400.00 </>	–

B.5 d: Reference Settings

No. (Addr. Hex)	Name	LCD Display	Description	Values	Page
d1-14 (028F) RUN	Frequency Reference 14	Reference 14	Sets the frequency reference for the drive. Setting units are determined by parameter o1-03.	Default: 0.00 Hz Min.: 0.00 Max.: 400.00 </>	–
d1-15 (0290) RUN	Frequency Reference 15	Reference 15	Sets the frequency reference for the drive. Setting units are determined by parameter o1-03.	Default: 0.00 Hz Min.: 0.00 Max.: 400.00 </>	–
d1-16 (0291) RUN	Frequency Reference 16	Reference 16	Sets the frequency reference for the drive. Setting units are determined by parameter o1-03.	Default: 0.00 Hz Min.: 0.00 Max.: 400.00 </>	–
d1-17 (0292) RUN	Jog Frequency Reference	Jog Reference	Sets the frequency reference for the drive. Setting units are determined by parameter o1-03.	Default: 6.00 Hz Min.: 0.00 Max.: 400.00 </>	–

</> Range upper limit is determined by parameters d2-01, Frequency Reference Upper Limit, and E1-04, Maximum Output Frequency.

◆ d2: Frequency Upper/Lower Limits

No. (Addr. Hex.)	Name	LCD Display	Description	Setting	Page
d2-01 (0289)	Frequency Reference Upper Limit	Ref Upper Limit	Sets the frequency reference upper limit as a percentage of the maximum output frequency.	Default: 100.0% Min.: 0.0 Max.: 110.0	–
d2-02 (028A)	Frequency Reference Lower Limit	Ref Lower Limit	Sets the frequency reference lower limit as a percentage of the maximum output frequency.	Default: 0.0% Min.: 0.0 Max.: 110.0	–
d2-03 (0293)	Master Speed Reference Lower Limit	Ref1 Lower Limit	Sets the lower limit for frequency references from analog inputs as a percentage of the maximum output frequency.	Default: 0.0% Min.: 0.0 Max.: 110.0	–

◆ d3: Jump Frequency

No. (Addr. Hex)	Name	LCD Display	Description	Values	Page
d3-01 (0294)	Jump Frequency 1	Jump Freq 1	Eliminates problems with resonant vibration of the motor/machine by avoiding continuous operation in predefined frequency ranges. The drive accelerates and decelerates the motor through the prohibited frequency ranges. Setting 0.0 disables this function. Parameters must be set so that $d3-01 \geq d3-02 \geq d3-03$.	Default: 0.0 Hz Min.: 0.0 Max.: 400.0	–
d3-02 (0295)	Jump Frequency 2	Jump Freq 2	Eliminates problems with resonant vibration of the motor/machine by avoiding continuous operation in predefined frequency ranges. The drive accelerates and decelerates the motor through the prohibited frequency ranges. Setting 0.0 disables this function. Parameters must be set so that $d3-01 \geq d3-02 \geq d3-03$.	Default: 0.0 Hz Min.: 0.0 Max.: 400.0	–
d3-03 (0296)	Jump Frequency 3	Jump Freq 3	Eliminates problems with resonant vibration of the motor/machine by avoiding continuous operation in predefined frequency ranges. The drive accelerates and decelerates the motor through the prohibited frequency ranges. Setting 0.0 disables this function. Parameters must be set so that $d3-01 \geq d3-02 \geq d3-03$.	Default: 0.0 Hz Min.: 0.0 Max.: 400.0	–
d3-04 (0297)	Jump Frequency Width	Jump Bandwidth	Sets the dead-band width around each selected prohibited frequency reference point.	Default: 1.0 Hz Min.: 0.0 Max.: 20.0	–

◆ d4: Frequency Reference Hold and Up/Down 2 Function

No. (Addr. Hex)	Name	LCD Display	Description	Values	Page
d4-01 (0298)	Frequency Reference Hold Function Selection	Fref Hold Sel 0: Disabled 1: Enabled	0: Disabled. Drive starts from zero when the power is switched on. 1: Enabled. At power up, the drive starts the motor at the Hold frequency that was saved.	Default: 0 Range: 0, 1	–
d4-03 (02AA) [RUN]	Frequency Reference Bias Step (Up/Down 2)	Up/Dn 2 Step Lvl	Sets the bias added to the frequency reference when the Up 2 and Down 2 digital inputs are enabled (H1-□□ = 75, 76).	Default: 0.00 Hz Min.: 0.00 Max.: 99.99	–
d4-04 (02AB) [RUN]	Frequency Reference Bias Accel/Decel (Up/Down 2)	Up/Dn 2 Ramp Sel 0: Sel Acc/Dec Time 1: Acc/Dec Time 4	0: Use selected accel/decel time. 1: Use 10-second accel/decel time.	Default: 0 Range: 0, 1	–
d4-05 (02AC) [RUN]	Frequency Reference Bias Operation Mode Selection (Up/Down 2)	Up/Dn 2 Bias Sel 0: Hold Bias Value 1: Reset Bias Value	0: Bias value is held if no input Up 2 or Down 2 is active. 1: When the Up 2 reference and Down 2 reference are both on or both off, the applied bias becomes 0. The specified accel/decel times are used for acceleration or deceleration.	Default: 0 Range: 0, 1	–
d4-06 (02AD)	Frequency Reference Bias (Up/Down 2)	Up/Dn 2 Bias Lvl	The Up/Down 2 bias value is saved in d4-06 when the frequency reference is not input by the digital operator. Set as a percentage of the maximum output frequency.	Default: 0.0% Min.: -99.9 Max.: 100.0	–
d4-07 (02AE) [RUN]	Analog Frequency Reference Fluctuation Limit (Up/Down 2)	Up/Dn 2 FluctLim	Limits how much the frequency reference is allowed to change while an input terminal set for Up 2 or Down 2 is enabled. If the frequency reference changes for more than the set value, then the bias value is held and the drive accelerates or decelerates to the frequency reference. Set as a percentage of the maximum output frequency.	Default: 1.0% Min.: 0.1 Max.: 100.0	–
d4-08 (02AF) [RUN]	Frequency Reference Bias Upper Limit (Up/Down 2)	Up/Dn 2 UpperLim	Sets the upper limit for the bias and the value that can be saved in d4-06. Set as a percentage of the maximum output frequency.	Default: 100.0% Min.: 0.0 Max.: 100.0	–
d4-09 (02B0) [RUN]	Frequency Reference Bias Lower Limit (Up/Down 2)	Up/Dn 2 LowerLim	Sets the lower limit for the bias and the value that can be saved in d4-06. Set as a percentage of the maximum output frequency.	Default: 0.0% Min.: -99.9 Max.: 0.0	–
d4-10 (02B6)	Up/Down Frequency Reference Limit Selection	Up/Dn LowLim Sel 0: D2-02 or Analog 1: D2-02 Only	0: The lower limit is determined by d2-02 or an analog input. 1: The lower limit is determined by d2-02.	Default: 0 Range: 0, 1	–

B.6 E: Motor Parameters

◆ E1: V/f Pattern for Motor 1

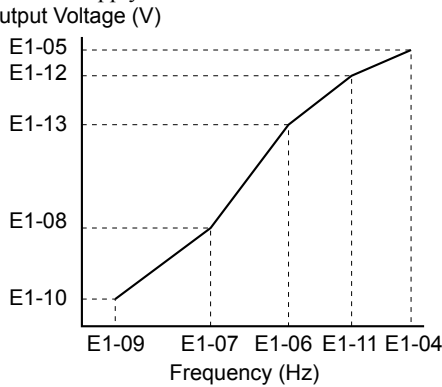
No. (Addr. Hex)	Name	LCD Display	Description	Values	Page
E1-03 (0302)	V/f Pattern Selection	V/F Selection 0: 50 Hz 1: 60 Hz Saturation 2: 50 Hz Saturation 3: 72 Hz 4: 50 Hz VT1 5: 50 Hz VT2 6: 60 Hz VT1 7: 60 Hz VT2 8: 50 Hz HST1 9: 50 Hz HST2 A: 60 Hz HST1 B: 60 Hz HST2 C: 90 Hz D: 120 Hz E: 180 Hz F: Custom V/F	0: 50 Hz, Constant torque 1 1: 60 Hz, Constant torque 2 2: 60 Hz, Constant torque 3 (50 Hz base) 3: 72 Hz, Constant torque 4 (60 Hz base) 4: 50 Hz, Variable torque 1 5: 50 Hz, Variable torque 2 6: 60 Hz, Variable torque 1 7: 60 Hz, Variable torque 2 8: 50 Hz, High starting torque 1 9: 50 Hz, High starting torque 2 A: 60 Hz, High starting torque 3 B: 60 Hz, High starting torque 4 C: 90 Hz (60 Hz base) D: 120 Hz (60 Hz base) E: 180 Hz (60 Hz base) F: Custom V/f, E1-04 through E1-13 settings define the V/f pattern	Default: F <2> Range: 0 to 9; A to F <3>	–
E1-04 (0303)	Maximum Output Frequency	Max Frequency	<p>Parameters E1-04 and E1-06 to E1-13 can only be changed when E1-03 is set to F.</p> <p>To set linear V/f characteristics, set the same values for E1-07 and E1-09.</p> <p>In this case, the setting for E1-08 will be disregarded. Ensure that the five frequencies are set according to the following rules to prevent triggering an oPE10 fault: $E1-09 \leq E1-07 < E1-06 \leq E1-11 \leq E1-04$</p> <p>Setting E1-11 to 0 disables both E1-11 and E1-12 and the above conditions do not apply.</p> 	Default: 60.0 Min.: 40.0 Max.: 400.0	–
E1-05 (0304)	Maximum Voltage	Max Voltage		Default: <4> Min.: 0.0 V Max.: 255.0 V <1>	–
E1-06 (0305)	Base Frequency	Base Frequency		Default: 60.0 Min.: 0.0 Max.: E1-04	–
E1-07 (0306)	Middle Output Frequency	Mid Frequency A		Default: 3.0 Min.: 0.0 Max.: E1-04	–
E1-08 (0307)	Middle Output Frequency Voltage	Mid Voltage A		Default: <4> Min.: 0.0 V Max.: 255.0 V <1>	–
E1-09 (0308)	Minimum Output Frequency	Min Frequency		Default: <4> Min.: 0.0 Max.: E1-04	–
E1-10 (0309)	Minimum Output Frequency Voltage	Min Voltage		Default: <4> Min.: 0.0 V Max.: 255.0 V <1>	–
E1-11 (030A) <4>	Middle Output Frequency 2	Mid Frequency B		Default: 0.0 Hz Min.: 0.0 Max.: E1-04	–
E1-12 (030B) <4>	Middle Output Frequency Voltage 2	Mid Voltage B		Default: 0.0 V Min.: 0.0 Max.: 255.0 V <1>	–
E1-13 (030C)	Base Voltage	Base Voltage		Default: 0.0 V <4> Min.: 0.0 Max.: 255.0 V <1>	–

Note: Some parameters may not be available depending on the control mode.

<1> Values shown are specific to 200 V class drives. Double the value for 400 V class drives.

<2> Parameter setting value is not reset to the default value when the drive is initialized.

<3> The setting value is F in OLV.

<4> Default setting is determined by parameters A1-02, Control Method Selection, and o2-04, Drive Model Selection.

- <7> When E1-13, Base Voltage, is set to 0.0, output voltage is controlled with E1-05, Maximum Voltage, = E1-13. When Auto-Tuning is performed, E1-05 and E1-13 are automatically set to the same value.
- <8> Parameter ignored when E1-11 (Motor 1 Mid Output Frequency 2) and E1-12 (Motor 1 Mid Output Frequency Voltage 2) are set to 0.0.

◆ E2: Motor 1 Parameters

No. (Addr. Hex)	Name	LCD Display	Description	Values	Page
E2-01 (030E)	Motor Rated Current	Motor Rated FLA	Sets the motor nameplate full load current in amps. Automatically set during Auto-Tuning.	Default: <1> Min.: 10% of drive rated current Max.: 150% of drive rated current <2>	174
E2-02 (030F)	Motor Rated Slip	Motor Rated Slip	Sets the motor rated slip. Automatically set during Auto-Tuning.	Default: <1> Min.: 0.00 Hz Max.: 20.00 Hz	–
E2-03 (0310)	Motor No-Load Current	No-Load Current	Sets the no-load current for the motor. Automatically set during Auto-Tuning.	Default: <1> Min.: 0.00 A Max.: E2-01 <2>	–
E2-04 (0311)	Number of Motor Poles	Number of Poles	Sets the number of motor poles. Automatically set during Auto-Tuning.	Default: 2 Min.: 2 Max.: 48	–
E2-05 (0312)	Motor Line-to-Line Resistance	Term Resistance	Sets the phase-to-phase motor resistance. Automatically set during Auto-Tuning.	Default: <1> Min.: 0.000 Ω Max.: 65.000 Ω	–
E2-06 (0313)	Motor Leakage Inductance	Leak Inductance	Sets the voltage drop due to motor leakage inductance as a percentage of motor rated voltage. Automatically set during Auto-Tuning.	Default: <1> Min.: 0.0% Max.: 40.0%	–
E2-07 (0314)	Motor Iron-Core Saturation Coefficient 1	Saturation Comp1	OLV Sets the motor iron saturation coefficient at 50% of magnetic flux. Automatically set during Auto-Tuning.	Default: 0.50 Min.: 0.00 Max.: 0.50	–
E2-08 (0315)	Motor Iron-Core Saturation Coefficient 2	Saturation Comp2	OLV Sets the motor iron saturation coefficient at 75% of magnetic flux. Automatically set during Auto-Tuning.	Default: 0.75 Min.: E2-07 Max.: 0.75	–
E2-09 (0316)	Motor Mechanical Loss	Mechanical Loss	OLV Sets the motor mechanical loss as a percentage of motor rated power (kW).	Default: 0.0% Min.: 0.0 Max.: 10.0	–
E2-10 (0317)	Motor Iron Loss for Torque Compensation	Motor Iron Loss	Sets the motor iron loss.	Default: <1> Min.: 0 W Max.: 65535 W	–
E2-11 (0318)	Motor Rated Power	Mtr Rated Power	Sets the motor rated power in kilowatts (1 HP = 0.746 kW). Automatically set during Auto-Tuning.	Default: <1> Min.: 0.00 kW Max.: 650.00 kW	–
E2-20 (1103) [RUN]	Motor Service Factor Amps	Motor SF Amps	Sets the Motor Overload Current level for oL1 fault. When parameter is set to 0, Motor Rated Current (E2-01) is used instead for the oL1 fault calculation.	Default: 0.00 A <4> Range: <3>	–

- <1> Default setting is dependent on parameter o2-04, Drive Model Selection.
- <2> Display is in the following units:
2□0028, 2□0042, and 4□0011 to 4□0027: 0.01 A units
2□0054 to 2□0248 and 4□0034 to 4□0930: 0.1 A units
- <3> Range and resolution are dependent on drive size. Upper limit is 150% of drive ND current. When setting to a non-zero value, lower limit is 10% of drive ND current.
- <4> Default resolution is dependent on drive size.

B.7 F: Option Settings

F parameters program the drive to function with option cards.

◆ F4: Analog Monitor Card Settings (AO-A3)

No. (Addr. Hex)	Name	LCD Display	Description	Values	Page
F4-01 (0391)	Terminal V1 Monitor Selection	AO Ch1 Select	Sets the monitor signal for output from terminal V1. Set this parameter to the last three digits of the desired U□-□□ monitor. Some U parameters are available only in certain control modes.	Default: 102 Range: 000 to 999 </>	-
F4-02 (0392) RUN	Terminal V1 Monitor Gain	AO Ch1 Gain	Sets the gain for voltage output via terminal V1.	Default: 100.0% Min.: -999.9 Max.: 999.9	-
F4-03 (0393)	Terminal V2 Monitor Selection	AO Ch2 Select	Sets the monitor signal for output from terminal V2. Set this parameter to the last three digits of the desired U□-□□ monitor. Some U parameters are available only in certain control modes.	Default: 103 Range: 000 to 999 </>	-
F4-04 (0394) RUN	Terminal V2 Monitor Gain	AO Ch2 Gain	Sets the gain for voltage output via terminal V2.	Default: 50.0% Min.: -999.9 Max.: 999.9	-
F4-05 (0395) RUN	Terminal V1 Monitor Bias	AO Ch1 Bias	Sets the amount of bias added to the voltage output via terminal V1.	Default: 0.0% Min.: -999.9 Max.: 999.9	-
F4-06 (0396) RUN	Terminal V2 Monitor Bias	AO Ch2 Bias	Sets the amount of bias added to the voltage output via terminal V2.	Default: 0.0% Min.: -999.9 Max.: 999.9	-
F4-07 (0397)	Terminal V1 Signal Level	AO Opt Level Ch1 0: 0-10 VDC 1: -10 +10 VDC	0: 0 to 10 V 1: -10 to 10 V	Default: 0 Range: 0, 1	-
F4-08 (0398)	Terminal V2 Signal Level	AO Opt Level Ch2 0: 0-10 VDC 1: -10 +10 VDC	0: 0 to 10 V 1: -10 to 10 V	Default: 0 Range: 0, 1	-

<1> Set to 000 or 031 when using the terminal in the through mode. This setting can adjust the V1 and V2 terminal output from PLC via MEMOBUS/Modbus communications or communications option.

◆ F5: Digital Output Card Settings (DO-A3)

No. (Addr. Hex)	Name	LCD Display	Description	Values	Page
F5-01 (0399)	Terminal P1-PC Output Selection	DO Ch1 Select	Sets the function for contact output terminals M1-M2, M3-M4, and photocoupler output terminals P1 through P6.	Default: 0 Range: 0 to 192	-
F5-02 (039A)	Terminal P2-PC Output Selection	DO Ch2 Select		Default: 1 Range: 0 to 192	-
F5-03 (039B)	Terminal P3-PC Output Selection	DO Ch3 Select		Default: 2 Range: 0 to 192	-
F5-04 (039C)	Terminal P4-PC Output Selection	DO Ch4 Select		Default: 4 Range: 0 to 192	-
F5-05 (039D)	Terminal P5-PC Output Selection	DO Ch5 Select		Default: 6 Range: 0 to 192	-
F5-06 (039E)	Terminal P6-PC Output Selection	DO Ch6 Select		Default: 37 Range: 0 to 192	-
F5-07 (039F)	Terminal M1-M2 Output Selection	DO Ch7 Select		Default: F Range: 0 to 192	-
F5-08 (03A0)	Terminal M3-M4 Output Selection	DO Ch8 Select		Default: F Range: 0 to 192	-

No. (Addr. Hex)	Name	LCD Display	Description	Values	Page
F5-09 (03A1)	DO-A3 Output Mode Selection	DO Function Sel	0: Output terminals are each assigned separate output functions. 1: Binary code output. 2: Use output terminal functions selected by parameters F5-01 through F5-08.	Default: 0 Range: 0 to 2	–

◆ F6: Communication Option Card Settings

Parameters F6-01 through F6-03 and F6-06 through F6-08 are used for DeviceNet and PROFIBUS options. Other parameters in the F6 group are used for communication-protocol-specific settings. For more details on a specific option card, refer to the instruction manual for the option.

No. (Addr. Hex)	Name	LCD Display	Description	Values	Page
F6-01 (03A2)	Communications Error Operation Selection	Comm Bus Flt Sel 0: Ramp to Stop 1: Coast to Stop 2: Fast-Stop 3: Alarm Only	0: Ramp to stop. Decelerate to stop using the deceleration time in C1-02. 1: Coast to stop. 2: Fast Stop. Decelerate to stop using the deceleration time in C1-09. 3: Alarm only.	Default: 1 Range: 0 to 3	–
F6-02 (03A3)	Pump Fault from Comm. Option Detection Selection	EF0 Detection 0: Always Detected 1: Only During Run	0: Always detected. 1: Detection during run only.	Default: 0 Range: 0, 1	–
F6-03 (03A4)	Pump Fault from Comm. Option Operation Selection	EF0 Fault Action 0: Ramp to Stop 1: Coast to Stop 2: Fast-Stop 3: Alarm Only	0: Ramp to stop. Decelerate to stop using the deceleration time in C1-02. 1: Coast to stop. 2: Fast Stop. Decelerate to stop using the deceleration time in C1-09. 3: Alarm only.	Default: 1 Range: 0 to 3	–
F6-04 (03A5)	bUS Error Detection Time	BUS Err Det Time	Sets the delay time for error detection if a bus error occurs.	Default: 2.0 s Min.: 0.0 Max.: 5.0	–
F6-07 (03A8)	Multi-Step Speed Enable/Disable Selection when NefRef/ComRef is Selected	Fref PrioritySel 0: Net/Com REF 1: MultiStep Speed	0: Multi-step reference disabled (same as F7) 1: Multi-step reference enabled (same as V7)	Default: 0 Range: 0, 1	–
F6-08 (036A) </>	Reset Communication Parameters	Com Prm Init Sel 0: Init Com Prms 1: No Init Com Prms	0: Communication-related parameters (F6-□□/ F7-□□) are not reset when the drive is initialized using A1-03. 1: Reset all communication-related parameters (F6-□□/ F7-□□) when the drive is initialized using A1-03.	Default: 0 Range: 0, 1	–
F6-30 (03CB)	PROFIBUS-DP Node Address	PB Node Address	Sets the node address.	Default: 0 Min.: 0 Max.: 125	–
F6-31 (03CC)	PROFIBUS-DP Clear Mode Selection	PB Clear Select 0: Reset to Zero 1: Hold Prev Value	0: Resets drive operation with a Clear mode command. 1: Maintains the previous operation state when Clear mode command is given.	Default: 0 Range: 0, 1	–
F6-32 (03CD)	PROFIBUS-DP Data Format Selection	PB Map Select 0: PPO Type 1: Conventional	0: PPO Type 1: Conventional	Default: 0 Range: 0, 1	–
F6-50 (03C1)	DeviceNet MAC Address	DN MAC Address	Selects the drive MAC address.	Default: 64 Min.: 0 Max.: 64	–
F6-51 (03C2)	DeviceNet Communication Speed	DN Baud Rate 0: 125 kbps 1: 250 kbps 2: 500 kbps 3: Set from Network 4: Auto Detect	0: 125 kbps 1: 250 kbps 2: 500 kbps 3: Adjustable from network 4: Detect automatically	Default: 4 Range: 0 to 4	–
F6-52 (03C3)	DeviceNet PCA Setting	PCA Selection	Sets the format of the data set from the DeviceNet master to the drive.	Default: 21 Min.: 0 Max.: 255	–

B.7 F: Option Settings

No. (Addr. Hex)	Name	LCD Display	Description	Values	Page
F6-53 (03C4)	DeviceNet PPA Setting	PPA Selection	Sets the format of the data set from the drive to the DeviceNet master.	Default: 71 Min.: 0 Max.: 255	–
F6-54 (03C5)	DeviceNet Idle Mode Fault Detection	DN Idle Flt Det 0: Stop 1: Ignore	0: Enabled 1: Disabled, no fault detection	Default: 0 Range: 0, 1	–
F6-55 (03C6)	DeviceNet Baud Rate Monitor	DN BAUD RATE MEM 0: 125 kbps 1: 250 kbps 2: 500 kbps	Verifies the baud rate running on the network. 0: 125 kbps 1: 250 kbps 2: 500 kbps	Default: 0 Range: 0 to 2	–
F6-56 (03D7)	DeviceNet Speed Scaling	Speed Scale	Sets the scaling factor for the speed monitor in DeviceNet.	Default: 0 Min.: -15 Max.: 15	–
F6-57 (03D8)	DeviceNet Current Scaling	Current Scale	Sets the scaling factor for the output current monitor in DeviceNet.	Default: 0 Min.: -15 Max.: 15	–
F6-58 (03D9)	DeviceNet Torque Scaling	Torque Scale	Sets the scaling factor for the torque monitor in DeviceNet.	Default: 0 Min.: -15 Max.: 15	–
F6-59 (03DA)	DeviceNet Power Scaling	Power Scale	Sets the scaling factor for the power monitor in DeviceNet.	Default: 0 Min.: -15 Max.: 15	–
F6-60 (03DB)	DeviceNet Voltage Scaling	Voltage Scale	Sets the scaling factor for the voltage monitor in DeviceNet.	Default: 0 Min.: -15 Max.: 15	–
F6-61 (03DC)	DeviceNet Time Scaling	Time Scale	Sets the scaling factor for the time monitor in DeviceNet.	Default: 0 Min.: -15 Max.: 15	–
F6-62 (03DD)	DeviceNet Heartbeat Interval	DN Heart Beat	Sets the heartbeat interval for DeviceNet communications.	Default: 0 Min.: 0 Max.: 10	–
F6-63 (03DE)	DeviceNet Network MAC ID	DN MAC ID MEM	Saves and monitors settings 0 to 63 of F6-50 (DeviceNet MAC Address).	Default: 63 Min.: 0 Max.: 63	–
F6-64 to F6-71 (03DF to 03C8)	Reserved	–	Reserved for Dynamic I/O Assembly Parameters.	–	–

<1> Parameter setting value is not reset to the default value when the drive is initialized.

◆ **F7: Communication Option Card Settings (SI-EM3, SI-EN3, SI-EP3)**

F7 parameters are used for EtherNet/IP, Modbus TCP/IP, and PROFINET options. Other parameters in the F7 group are used for communication-protocol-specific settings. For more details on a specific option card, refer to the instruction manual for the option.

No. (Addr. Hex)	Name	LCD Display	Description	Values	Page
F7-01 (03E5) </>	IP Address 1	IP Address 1	Sets the most significant octet of network static IP address.	Default: 192 Range: 0 to 255	–
F7-02 (03E6) </>	IP Address 2	IP Address 2	Sets the second most significant octet of network static IP address.	Default: 168 Range: 0 to 255	–
F7-03 (03E7) </>	IP Address 3	IP Address 3	Sets the third most significant octet of network static IP address.	Default: 1 Range: 0 to 255	–
F7-04 (03E8) </>	IP Address 4	IP Address 4	Sets the fourth most significant octet of network static IP address.	Default: 20 Range: 0 to 255	–
F7-05 (03E9)	Subnet Mask 1	Subnet Mask 1	Sets the most significant octet of network static Subnet Mask.	Default: 255 Range: 0 to 255	–
F7-06 (03EA)	Subnet Mask 2	Subnet Mask 2	Sets the second most significant octet of network static Subnet Mask.	Default: 255 Range: 0 to 255	–
F7-07 (03EB)	Subnet Mask 3	Subnet Mask 3	Sets the third most significant octet of network static Subnet Mask.	Default: 255 Range: 0 to 255	–
F7-08 (03EC)	Subnet Mask 4	Subnet Mask 4	Sets the fourth most significant octet of network static Subnet Mask.	Default: 0 Range: 0 to 255	–
F7-09 (03ED)	Gateway Address 1	Gateway IP Add 1	Sets the most significant octet of network Gateway address.	Default: 192 Range: 0 to 255	–
F7-10 (03EE)	Gateway Address 2	Gateway IP Add 2	Sets the second most significant octet of network Gateway address.	Default: 168 Range: 0 to 255	–
F7-11 (03EF)	Gateway Address 3	Gateway IP Add 3	Sets the third most significant octet of network Gateway address.	Default: 1 Range: 0 to 255	–
F7-12 (03F0)	Gateway Address 4	Gateway IP Add 4	Sets the fourth most significant octet of network Gateway address.	Default: 1 Range: 0 to 255	–
F7-13 (03F1)	Address Mode at Startup	IP Add Mode Sel 0: User Defined 1: BOOTP 2: DHCP	Select the option address setting method. 0: Static </> 1: BOOTP 2: DHCP	Default: 2 Range: 0 to 2	–
F7-14 (03F2)	Duplex Mode Selection	Duplex Select 0: Half/Half 1: Auto/Auto 2: Full/Full 3: Half/Auto 4: Half/Full 5: Auto/Half 6: Auto/Full 7: Full/Half 8: Full/Auto	Selects duplex mode setting. 0: Half duplex forced 1: Auto-negotiate duplex mode and communication speed 2: Full duplex forced 3: Half duplex forced (port 1)/Auto-negotiate duplex mode and communication speed (port 2) 4: Half duplex forced (port 1)/Full duplex forced (port 2) 5: Auto-negotiate duplex mode and communication speed (port 1)/Half duplex forced (port 2) 6: Auto-negotiate duplex mode and communication speed (port 1)/Full duplex forced (port 2) 7: Full duplex forced (port 1)/Half duplex forced (port 2) 8: Full duplex forced (port 1)/Auto-negotiate duplex mode and communication speed (port 2)	Default: 1 Range: 0 to 8	–
F7-15 (03F3)	Communication Speed Selection	Baud Rate 10: 10/10 Mbps 100: 100/100 Mbps 101: 10/100 Mbps 102: 100/10 Mbps	Sets the communication speed. 10: 10 Mbps 100: 100 Mbps 101: 10 Mbps (port 1)/100 Mbps (port 2) 102: 100 Mbps (port 1)/10 Mbps (port 2)	Default: 10 Range: 10 to 102	–
F7-16 (03F4)	Communication Loss Time Out	CommLoss Tout	Sets the time out value for communication loss detection in tenths of a second. A value of 0 disables the connection time out. Example: An entered value of 100 represents 10.0 seconds.	Default: 0.0 s Min.: 0.0 Max.: 30.0	–

B.7 F: Option Settings

No. (Addr. Hex)	Name	LCD Display	Description	Values	Page
F7-17 (03F5)	EtherNet/IP Speed Scaling Factor	EN Speed Scale	Sets the scaling factor for the speed monitor in EtherNet/IP Class ID 2AH Object.	Default: 0 Min.: -15 Max.: 15	–
F7-18 (03F6)	EtherNet/IP Current Scaling Factor	EN Current Scale	Sets the scaling factor for the output current monitor in EtherNet/IP Class ID 2AH Object.	Default: 0 Min.: -15 Max.: 15	–
F7-19 (03F7)	EtherNet/IP Torque Scaling Factor	EN Torque Scale	Sets the scaling factor for the torque monitor in EtherNet/IP Class ID 2AH Object.	Default: 0 Min.: -15 Max.: 15	–
F7-20 (03F8)	EtherNet/IP Power Scaling Factor	EN Power Scale	Sets the scaling factor for the power monitor in EtherNet/IP Class ID 2AH Object.	Default: 0 Min.: -15 Max.: 15	–
F7-21 (03F9)	EtherNet/IP Voltage Scaling Factor	EN Voltage Scale	Sets the scaling factor for the voltage monitor in EtherNet/IP Class ID 2AH Object.	Default: 0 Min.: -15 Max.: 15	–
F7-22 (03FA)	EtherNet/IP Time Scaling	EN Time Scale	Sets the scaling factor for the time monitor in EtherNet/IP Class ID 2AH Object.	Default: 0 Min.: -15 Max.: 15	–
F7-23 to F7-27 (03FB to 03FF) F7-28 to F7-32 (0370 to 0374)	Dynamic Output Assembly Parameters	–	Parameters used in Output Assembly 116. Each parameter contains a MEMOBUS/Modbus address. The value received for Output Assembly 116 will be written to this corresponding MEMOBUS/Modbus address. A MEMOBUS/Modbus address value of 0 means that the value received for Output Assembly 116 will not be written to any MEMOBUS/Modbus register.	Default: 0	–
F7-33 to F7-42 (0375 to 037E)	Dynamic Input Assembly Parameters	–	Parameters used in Input Assembly 166. Each parameter contains a MEMOBUS/Modbus address. The value sent for Input Assembly 166 will be read from this corresponding MEMOBUS/Modbus address. A MEMOBUS/Modbus address value of 0 means that the value sent for Input Assembly 166 is not defined by the user, therefore the option default register value will be returned.	Default: 0	–
F7-60 (0780)	PZD1 Write	PZD1 Write	Sets MEMOBUS/Modbus address for PZD1 Write (PPO Write). Values 0 to 2 enable the PZD1 Write as STW.	Default: 0 Min.: 0 Max.: FFFF	–
F7-61 (0781)	PZD2 Write	PZD2 Write	Sets MEMOBUS/Modbus address for PZD2 Write (PPO Write). Values 0 to 2 enable the PZD2 Write as HSW.	Default: 0 Min.: 0 Max.: FFFF	–
F7-62 (0782)	PZD3 Write	PZD3 Write	Sets MEMOBUS/Modbus address for PZD3 Write (PPO Write). Values 0 to 2 disable the PZD3 Write.	Default: 0 Min.: 0 Max.: FFFF	–
F7-63 (0783)	PZD4 Write	PZD4 Write	Sets MEMOBUS/Modbus address for PZD4 Write (PPO Write). Values 0 to 2 disable the PZD4 Write.	Default: 0 Min.: 0 Max.: FFFF	–
F7-64 (0784)	PZD5 Write	PZD5 Write	Sets MEMOBUS/Modbus address for PZD5 Write (PPO Write). Values 0 to 2 disable the PZD5 Write.	Default: 0 Min.: 0 Max.: FFFF	–
F7-65 (0785)	PZD6 Write	PZD6 Write	Sets MEMOBUS/Modbus address for PZD6 Write (PPO Write). Values 0 to 2 disable the PZD6 Write.	Default: 0 Min.: 0 Max.: FFFF	–
F7-66 (0786)	PZD7 Write	PZD7 Write	Sets MEMOBUS/Modbus address for PZD7 Write (PPO Write). Values 0 to 2 disable the PZD7 Write.	Default: 0 Min.: 0 Max.: FFFF	–
F7-67 (0787)	PZD8 Write	PZD8 Write	Sets MEMOBUS/Modbus address for PZD8 Write (PPO Write). Values 0 to 2 disable the PZD8 Write.	Default: 0 Min.: 0 Max.: FFFF	–
F7-68 (0788)	PZD9 Write	PZD9 Write	Sets MEMOBUS/Modbus address for PZD9 Write (PPO Write). Values 0 to 2 disable the PZD9 Write.	Default: 0 Min.: 0 Max.: FFFF	–
F7-69 (0789)	PZD10 Write	PZD10 Write	Sets MEMOBUS/Modbus address for PZD10 Write (PPO Write). Values 0 to 2 disable the PZD10 Write.	Default: 0 Min.: 0 Max.: FFFF	–

No. (Addr. Hex)	Name	LCD Display	Description	Values	Page
F7-70 (078A)	PZD1 Read	PZD1 Read	Sets MEMOBUS/Modbus address for PZD1 Read (PPO Read). Values 0 to 2 enable the PZD1 Read as ZSW.	Default: 0 Min.: 0 Max.: FFFF	–
F7-71 (078B)	PZD2 Read	PZD2 Read	Sets MEMOBUS/Modbus address for PZD2 Read (PPO Read). Values 0 to 2 enable the PZD2 Read as HIW.	Default: 0 Min.: 0 Max.: FFFF	–
F7-72 (078C)	PZD3 Read	PZD3 Read	Sets MEMOBUS/Modbus address for PZD3 Read (PPO Read). Values 0 to 2 disable the PZD3 Read.	Default: 0 Min.: 0 Max.: FFFF	–
F7-73 (078D)	PZD4 Read	PZD4 Read	Sets MEMOBUS/Modbus address for PZD4 Read (PPO Read). Values 0 to 2 disable the PZD4 Read.	Default: 0 Min.: 0 Max.: FFFF	–
F7-74 (078E)	PZD5 Read	PZD5 Read	Sets MEMOBUS/Modbus address for PZD5 Read (PPO Read). Values 0 to 2 disable the PZD5 Read.	Default: 0 Min.: 0 Max.: FFFF	–
F7-75 (078F)	PZD6 Read	PZD6 Read	Sets MEMOBUS/Modbus address for PZD6 Read (PPO Read). Values 0 to 2 disable the PZD6 Read.	Default: 0 Min.: 0 Max.: FFFF	–
F7-76 (0790)	PZD7 Read	PZD7 Read	Sets MEMOBUS/Modbus address for PZD7 Read (PPO Read). Values 0 to 2 disable the PZD7 Read.	Default: 0 Min.: 0 Max.: FFFF	–
F7-77 (0791)	PZD8 Read	PZD8 Read	Sets MEMOBUS/Modbus address for PZD8 Read (PPO Read). Values 0 to 2 disable the PZD8 Read.	Default: 0 Min.: 0 Max.: FFFF	–
F7-78 (0792)	PZD9 Read	PZD9 Read	Sets MEMOBUS/Modbus address for PZD9 Read (PPO Read). Values 0 to 2 disable the PZD9 Read.	Default: 0 Min.: 0 Max.: FFFF	–
F7-79 (0793)	PZD10 Read	PZD10 Read	Sets MEMOBUS/Modbus address for PZD10 Read (PPO Read). Values 0 to 2 disable the PZD10 Read.	Default: 0 Min.: 0 Max.: FFFF	–

<1> Cycle power for setting changes to take effect.

<2> If F7-13 is set to 0, then all IP Addresses (as defined with parameters F7-01 to F7-04) must be unique.

B.8 H Parameters: Multi-Function Terminals

H parameters assign functions to the multi-function input and output terminals.

◆ H1: Multi-Function Digital Inputs

No. (Addr. Hex)	Name	LCD Display	Description	Values	Page
H1-01 (0438)	Multi-Function Digital Input Terminal S1 Function Selection	Term S1 Func Sel	Assigns a function to the multi-function digital inputs. Refer to pages 175 to 348 for descriptions of setting values. Note: Set unused terminals to F.	Default: 40 (F) </> Min.: 0 Max.: B0	175
H1-02 (0439)	Multi-Function Digital Input Terminal S2 Function Selection	Term S2 Func Sel	Assigns a function to the multi-function digital inputs. Refer to pages 175 to 348 for descriptions of setting values. Note: Set unused terminals to F.	Default: F (F) </> Min.: 0 Max.: B0	175
H1-03 (0400)	Multi-Function Digital Input Terminal S3 Function Selection	Term S3 Func Sel	Assigns a function to the multi-function digital inputs. Refer to pages 175 to 348 for descriptions of setting values. Note: Set unused terminals to F.	Default: 26 Min.: 0 Max.: B0	175
H1-04 (0401)	Multi-Function Digital Input Terminal S4 Function Selection	Term S4 Func Sel	Assigns a function to the multi-function digital inputs. Refer to pages 175 to 348 for descriptions of setting values. Note: Set unused terminals to F.	Default: 14 Min.: 0 Max.: 9F	175
H1-05 (0402)	Multi-Function Digital Input Terminal S5 Function Selection	Term S5 Func Sel	Assigns a function to the multi-function digital inputs. Refer to pages 175 to 348 for descriptions of setting values. Note: Set unused terminals to F.	Default: 8D (0) </> Min.: 0 Max.: B0	175
H1-06 (0403)	Multi-Function Digital Input Terminal S6 Function Selection	Term S6 Func Sel	Assigns a function to the multi-function digital inputs. Refer to pages 175 to 348 for descriptions of setting values. Note: Set unused terminals to F.	Default: 80 (3) </> Min.: 0 Max.: B0	175
H1-07 (0404)	Multi-Function Digital Input Terminal S7 Function Selection	Term S7 Func Sel	Assigns a function to the multi-function digital inputs. Refer to pages 175 to 348 for descriptions of setting values. Note: Set unused terminals to F.	Default: 81 (4) </> Min.: 0 Max.: B0	175
H1-08 (0405)	Multi-Function Digital Input Terminal S8 Function Selection	Term S8 Func Sel	Assigns a function to the multi-function digital inputs. Refer to pages 175 to 348 for descriptions of setting values. Note: Set unused terminals to F.	Default: F Min.: 0 Max.: B0	175
H1-31 (09E1) <input type="checkbox"/> RUN	Terminal S1 On-Delay Time	Term S1 On-Delay	Sets the length of time that Terminal S1 must be closed before the drive performs the programmed function.	Default: 0.0 s Min.: 0.0 Max.: 3000.0	–
H1-32 (09E2) <input type="checkbox"/> RUN	Terminal S2 On-Delay Time	Term S2 On-Delay	Sets the length of time that Terminal S2 must be closed before the drive performs the programmed function.	Default: 0.0 s Min.: 0.0 Max.: 3000.0	–
H1-33 (09E3) <input type="checkbox"/> RUN	Terminal S3 On-Delay Time	Term S3 On-Delay	Sets the length of time that Terminal S3 must be closed before the drive performs the programmed function.	Default: 0.0 s Min.: 0.0 Max.: 3000.0	–
H1-34 (09E4) <input type="checkbox"/> RUN	Terminal S4 On-Delay Time	Term S4 On-Delay	Sets the length of time that Terminal S4 must be closed before the drive performs the programmed function.	Default: 0.0 s Min.: 0.0 Max.: 3000.0	–
H1-35 (09E5) <input type="checkbox"/> RUN	Terminal S5 On-Delay Time	Term S5 On-Delay	Sets the length of time that Terminal S5 must be closed before the drive performs the programmed function.	Default: 0.0 s Min.: 0.0 Max.: 3000.0	–
H1-36 (09E6) <input type="checkbox"/> RUN	Terminal S6 On-Delay Time	Term S6 On-Delay	Sets the length of time that Terminal S6 must be closed before the drive performs the programmed function.	Default: 0.0 s Min.: 0.0 Max.: 3000.0	–
H1-37 (09E7) <input type="checkbox"/> RUN	Terminal S7 On-Delay Time	Term S7 On-Delay	Sets the length of time that Terminal S7 must be closed before the drive performs the programmed function.	Default: 0.0 s Min.: 0.0 Max.: 3000.0	–
H1-38 (09E8) <input type="checkbox"/> RUN	Terminal S8 On-Delay Time	Term S8 On-Delay	Sets the length of time that Terminal S8 must be closed before the drive performs the programmed function.	Default: 0.0 s Min.: 0.0 Max.: 3000.0	–

No. (Addr. Hex)	Name	LCD Display	Description	Values	Page
H1-41 (09EB) RUN	Terminal S1 Off-Delay Time	Term S1 OffDelay	Sets the length of time needed for Terminal S1 to be open before the drive removes the programmed function.	Default: 0.0 s Min.: 0.0 Max.: 3000.0	–
H1-42 (09EC) RUN	Terminal S2 Off-Delay Time	Term S2 OffDelay	Sets the length of time needed for Terminal S2 to be open before the drive removes the programmed function.	Default: 0.0 s Min.: 0.0 Max.: 3000.0	–
H1-43 (09ED) RUN	Terminal S3 Off-Delay Time	Term S3 OffDelay	Sets the length of time needed for Terminal S3 to be open before the drive removes the programmed function.	Default: 0.0 s Min.: 0.0 Max.: 3000.0	–
H1-44 (09EE) RUN	Terminal S4 Off-Delay Time	Term S4 OffDelay	Sets the length of time needed for Terminal S4 to be open before the drive removes the programmed function.	Default: 0.0 s Min.: 0.0 Max.: 3000.0	–
H1-45 (09EF) RUN	Terminal S5 Off-Delay Time	Term S5 OffDelay	Sets the length of time needed for Terminal S5 to be open before the drive removes the programmed function.	Default: 0.0 s Min.: 0.0 Max.: 3000.0	–
H1-46 (09F0) RUN	Terminal S6 Off-Delay Time	Term S6 OffDelay	Sets the length of time needed for Terminal S6 to be open before the drive removes the programmed function.	Default: 0.0 s Min.: 0.0 Max.: 3000.0	–
H1-47 (09F4) RUN	Terminal S7 Off-Delay Time	Term S7 OffDelay	Sets the length of time needed for Terminal S7 to be open before the drive removes the programmed function.	Default: 0.0 s Min.: 0.0 Max.: 3000.0	–
H1-48 (09F5) RUN	Terminal S8 Off-Delay Time	Term S8 OffDelay	Sets the length of time needed for Terminal S8 to be open before the drive removes the programmed function.	Default: 0.0 s Min.: 0.0 Max.: 3000.0	–

<1> Value in parenthesis is the default setting when a 3-Wire initialization is performed (A1-03 = 3330).

H1 Multi-Function Digital Input Selections					
H1-□□ Setting	Function	LCD Display	Description	Page	
0	3-Wire sequence	3-Wire Control	Closed: Reverse rotation (only if the drive is set up for 3-Wire sequence) Terminals S1 and S2 are automatically set up for the Run command and Stop command.	176	
2	External reference 1/2 selection	Ext Ref Sel	Open: Run command and frequency reference source 1 (determined by b1-01 and b1-02) Closed: Run command and frequency reference source 2 (determined by b1-15 and b1-16)	–	
3	Multi-Step Speed Reference 1	Multi-Step Ref 1	When input terminals are set to Multi-Step Speed References 1 through 3, switching combinations of those terminals will create a multi-step speed sequence using the frequency references set in d1-01 through d1-08.	–	
4	Multi-Step Speed Reference 2	Multi-Step Ref 2	When input terminals are set to Multi-Step Speed References 1 through 3, switching combinations of those terminals will create a multi-step speed sequence using the frequency references set in d1-01 through d1-08.	–	
5	Multi-Step Speed Reference 3	Multi-Step Ref 3	When input terminals are set to Multi-Step Speed References 1 through 3, switching combinations of those terminals will create a multi-step speed sequence using the frequency references set in d1-01 through d1-08.	–	
6	Jog reference selection	Jog Freq Ref	Closed: Jog frequency reference (d1-17) selected. Jog has priority over all other reference sources.	–	
7	Accel/decel time selection 1	Multi-Acc/Dec 1	Used to switch between accel/decel time 1 (set in C1-01, C1-02) and accel/decel time 2 (set in C1-03, C1-04).	–	
8	Baseblock command (N.O.)	Ext BaseBlk N.O.	Closed: No drive output	–	
9	Baseblock command (N.C.)	Ext BaseBlk N.C.	Open: No drive output	–	
A	Accel/decel ramp hold	Acc/Dec RampHold	Open: Accel/decel is not held Closed: The drive pauses during acceleration or deceleration and maintains the output frequency.	–	
B	Drive overheat alarm (oH2)	OH2 Alarm Signal	Closed: Closes when an oH2 alarm occurs	–	

B.8 H Parameters: Multi-Function Terminals

H1 Multi-Function Digital Input Selections				
H1-□□ Setting	Function	LCD Display	Description	Page
C	Analog terminal input selection	Term A2 Enable	Open: Function assigned by H3-14 is disabled. Closed: Function assigned by H3-14 is enabled.	–
F	Through mode	Term Not Used	Select this setting when the terminal is not used or when using the terminal in the pass-through mode. The terminal does not trigger a drive function, but can be used as digital input for the controller to which the drive is connected.	–
10	Up command	Up Command 1	The drive accelerates when the Up command terminal closes, and decelerates when the Down command closes. When both terminals are closed or both are open, the drive holds the frequency reference. The Up and Down commands must always be used in conjunction with one another.	–
11	Down command	Down Command 1	The drive accelerates when the Up command terminal closes, and decelerates when the Down command closes. When both terminals are closed or both are open, the drive holds the frequency reference. The Up and Down commands must always be used in conjunction with one another.	–
12	Forward Jog	Forward Jog	Closed: Runs forward at the Jog frequency d1-17.	–
13	Reverse Jog	Reverse Jog	Closed: Runs reverse at the Jog frequency d1-17.	–
14	Fault reset	Fault Reset	Closed: Resets faults if the cause is cleared and the Run command is removed.	–
15	Fast Stop (N.O.)	Fast-Stop N.O.	Closed: Decelerates at the Fast Stop time set to C1-09.	–
17	Fast Stop (N.C.)	Fast-Stop N.C.	Open: Decelerates to stop at the Fast Stop time set to C1-09.	–
18	Timer function input	Timer function	Triggers the timer set up by parameters b4-01 and b4-02. Must be set in conjunction with the timer function output (H2-□□ = 12).	–
19	PID disable	PID Disable	Open: PID control enabled Closed: PID control disabled	–
1B	Program lockout	Program Lockout	Open: Parameters cannot be edited (except for U1-01 if the reference source is assigned to the digital operator). Closed: Parameters can be edited and saved.	–
1E	Reference sample hold	Ref Sample Hold	Closed: Samples the analog frequency reference and operates the drive at that speed.	–
20 to 2F	Ext. Pump Fault	20: NO/Always Det, Ramp to Stop 21: NC/Always Det, Ramp to Stop 22: N.O., During run, ramp to stop 23: N.C., During run, ramp to stop 24: N.O., Always detected, coast to stop 25: N.C., Always detected, coast to stop 26: N.O., During run, coast to stop 27: N.C., During run, coast to stop 28: NO/ Always Det, Coast to Stop 29: NC/Always Det, Coast to Stop 2A: NO/During RUN, Coast to Stop 2B: NC/Always Det, Alarm Only 2D: NC/Always Det, Alarm Only 2E: NO/ During RUN, Alarm Only 2F: NC/During RUN, Alarm Only	20: N.O., Always detected, ramp to stop 21: N.C., Always detected, ramp to stop 22: N.O., During run, ramp to stop 23: N.C., During run, ramp to stop 24: N.O., Always detected, coast to stop 25: N.C., Always detected, coast to stop 26: N.O., During run, coast to stop 27: N.C., During run, coast to stop 28: N.O., Always detected, Fast Stop 29: N.C., Always detected, Fast Stop 2A: N.O., During run, Fast Stop 2B: N.C., During run, Fast Stop 2C: N.O., Always detected, alarm only (continue running) 2D: N.C., Always detected, alarm only (continue running) 2E: N.O., During run, alarm only (continue running) 2F: N.C., During run, alarm only (continue running)	–
30	PID integral reset	PID Intgrl Reset	Closed: Resets the PID control integral value.	–
31	PID integral hold	PID Intgrl Hold	Open: Performs integral operation. Closed: Maintains the current PID control integral value.	–
32	Multi-Step Speed Reference 4	Multi-Step Ref 4	Used in combination with input terminals set to Multi-Step Speed Reference 1, 2, and 3. Use parameters d1-09 to d1-16 to set reference values.	–

H1 Multi-Function Digital Input Selections				
H1-□□ Setting	Function	LCD Display	Description	Page
34	PID soft starter cancel	PID SFS Cancel	Open: PID soft starter is enabled. Closed: Disables the PID soft starter b5-17.	–
35	PID input level selection	PID Input Invert	Closed: Inverts the PID input signal.	–
40	Forward run command (2-Wire sequence)	FwdRun 2Wire Seq	Open: Stop Closed: Forward run Note: Cannot be set together with settings 42 or 43.	–
41	Reverse run command (2-Wire sequence)	RevRun 2WireSeq	Open: Stop Closed: Reverse run Note: Cannot be set together with settings 42 or 43.	–
42	Run command (2-Wire sequence 2)	Run/Stp 2WireSeq	Open: Stop Closed: Run Note: Cannot be set together with settings 40 or 41.	–
43	FWD/REV command (2-Wire sequence 2)	FWD/REV 2WireSeq	Open: Forward Closed: Reverse Note: Determines motor direction, but does not issue a Run command. Cannot be set together with settings 40 or 41.	–
47	Node setup	CanOpenNID Setup	Closed: Node setup for SI-S3 enabled.	–
51	Sequence Timer Disable	SeqTimer Disable	Closed: Drive ignores sequence timers and runs normally (based on b1-02/b1-16 source).	–
52	Sequence Timer Cancel	SeqTimer Cancel	Closed: When the input changes from open to closed, the currently active sequence timer is disabled. Operation will resume with the next scheduled sequence timer. Cycling the Run command after the current sequence timer has been canceled will re-enable the sequence timer.	–
60	DC Injection Braking command	DCInj Activate	Closed: Triggers DC Injection Braking.	–
61	External Speed Search command 1	Speed Search 1	Closed: Activates Current Detection Speed Search from the maximum output frequency (E1-04).	–
62	External Speed Search command 2	Speed Search 2	Closed: Activates Current Detection Speed Search from the frequency reference.	–
67	Communications test mode	Comm Test Mode	Tests the MEMOBUS/Modbus RS-422/RS-485 interface. Displays “PASS” if the test completes successfully.	–
6A	Drive enabled	Drive Enable	Open: Drive disabled. If this input is opened during run, the drive will stop as specified by b1-03. Closed: Ready for operation.	–
73	Low City Press	Low City Press	Indicates that sufficient or insufficient pressure is present on the inlet to the pump. Used mainly for pressure booster situations. Note: Parameter P4-21 determines if this input is normally open or normally closed.	–
75	Up 2 command	Up Command 2	Used to control the bias added to the frequency reference by the Up/Down 2 function. The Up 2 and Down 2 commands must always be used in conjunction with one another.	–
76	Down 2 command	Down Command 2	Used to control the bias added to the frequency reference by the Up/Down 2 function. The Up 2 and Down 2 commands must always be used in conjunction with one another.	–
7F	PID Bi-Directional Enable	PID BiDir Enable	Reserved.	–
80	HAND Mode	Hand Mode	Closed: HAND Mode operation. Frequency reference determined by P5-01 and P5-02. Open: Stop Mode when no Run command.	–
81	HAND Mode 2	Hand Mode 2	Closed: HAND Mode operation. Frequency reference determined by P5-05. Open: Stop Mode when no Run command.	–
82	PI Switch to Aux	PI Switch to Aux	Closed: PI Auxiliary Control (Q6-□□) becomes the primary PI loop, disabling the System PI controller (b5-□□). Overrides Q6-20 when set to 0 (Disable Effect on Speed Control).	–
83	Alternate Multi Setpoint (Q1-02)	AltMultiSP Q1-02	Closed: Q1-02 becomes the PID setpoint	–
84	Alternate Multi Setpoint (Q1-03)	AltMultiSP Q1-03	Closed: Q1-03 becomes the PID setpoint	–

B.8 H Parameters: Multi-Function Terminals

H1 Multi-Function Digital Input Selections				
H1-□□ Setting	Function	LCD Display	Description	Page
85	Alternate Multi Setpoint (Q1-04)	AltMultiSP Q1-04	Closed: Q1-04 becomes the PID setpoint	–
88	Volute-Thermostat Normally Open	Volute-TStat NO	Function active when the drive is running. Closed: Drive will trip on “VLTS - Volute-TStat Flt” Open: Thermostat fault not active Note: Setting H1-□□ = 88 and 89 simultaneously will trigger a “VLTS - Volute-TStat Flt”.	–
89	Volute-Thermostat Normally Closed	Volute-TStat NC	Function active when the drive is running. Closed: Thermostat fault not active Open: Drive will trip on “VLTS - Volute-TStat Flt” Note: Setting H1-□□ = 88 and 89 simultaneously will trigger a “VLTS - Volute-TStat Flt”.	–
8C	Disable Pre-Charge	Disable Pre-Chrg	Close to disable pre-charge.	–
8D	Multi Setpoint 1	Multi Setpoint 1	Selects between different PID Setpoints Open: Freq. Ref, q1-01, or q1-03 is PID setpoint. Closed: q1-02 or q1-04 is PID setpoint.	–
8E	Multi Setpoint 2	Multi Setpoint 2	Selects between different PID Setpoints Open: Freq. Ref, q1-01, or q1-02 is PID setpoint. Closed: q1-03 or q1-04 is PID setpoint.	–
8F	Low Water Level	Low Water	Function active in AUTO Mode during normal operation, also used with Pre-Charge function. Function logic depends on P1-30, Low Water Digital Input Configuration. P1-30 = 0 (Normally open) Closed: Low water level fault Open: Reservoir/Tank is filled to normal level P1-30 = 1 (Normally closed) Closed: Reservoir/Tank is filled to normal level Open: Low water level fault Pre-Charge function: Function uses the low water level input as “Tank/Reservoir” feedback to indicate that the water level has been reached.	–
90	High Water Level	High Water	Function active when the drive is running. Function logic depends on P1-31, High Water Digital Input Configuration. P1-31 = 0 (Normally open) Closed: High water level fault Open: Reservoir/Tank is filled to normal level P1-31 = 1 (Normally closed) Closed: Reservoir/Tank is filled to normal level Open: High water level fault	–
92	Reset Accumulated Volume	Reset Accum	Closed: Accumulated volume is reset to 0 and held at 0 if digital input remains closed.	–
95	Remove Drive Disable	Remote Drv Disbl	Closed: Prevents the drive from running when active for the time set in P4-26. Must be inactive for the time set in P4-27 to allow the drive to run again. Note: Parameter P4-25 determines if this input is normally open or normally closed.	–

◆ H2: Multi-Function Digital Outputs

No. (Addr. Hex)	Name	LCD Display	Description	Values	Page
H2-01 (040B)	Terminal M1-M2 function selection (relay)	M1-M2 Func Sel	Refer to H2 Multi-Function Digital Output Settings on pages 177 to 178 for descriptions of setting values.	Default: 37 Range: 0 to 1AC	177
H2-02 (040C)	Terminal M3-M4 function selection (relay)	M3-M4 Func Sel		Default: 42 Range: 0 to 1AC	177
H2-03 (040D)	Terminal MD-ME-MF function selection (relay)	MD/ME/MF Func Sel		Default: E Range: 0 to 1AC	177

No. (Addr. Hex)	Name	LCD Display	Description	Values	Page
H2-06 (0437)	Power Consumption Output Unit Selection	Pwr Mon Unit Sel	Sets the units for the output signal when Power Consumption Pulse Output or Regenerated Power Pulse Output are selected as the digital output (H2-01, H2-02, or H2-03 = 39 or 3A). 0: 0.1 kWh units 1: 1 kWh units 2: 10 kWh units 3: 100 kWh units 4: 1000 kWh units	Default: 1 Range: 0 to 4	–
H2-07 (0B3A)	MEMOBUS Register 1 Address Select	MFDO Regs1 Addr	Sets the addresses of the MEMOBUS/Modbus registers from which data will be sent to contact outputs 62 and 162.	Default: 1 Range: 1 to 1FFFH	–
H2-08 (0B3B)	MEMOBUS Register 1 Bit Select	MFDO Regs1 Bit	Sets the bits for the MEMOBUS/Modbus registers from which data will be sent to contact outputs 62 and 162.	Default: 0 Range: 0 to FFFFH	–
H2-09 (0B3C)	MEMOBUS Register 2 Address Select	MFDO Regs2 Addr	Sets the addresses of the MEMOBUS/Modbus registers from which data will be sent to contact outputs 63 and 163.	Default: 1 Range: 1 to 1FFFH	–
H2-10 (0B3D)	MEMOBUS Register 2 Bit Select	MFDO Regs2 Bit	Sets the bits for the MEMOBUS/Modbus registers from which data will be sent to contact outputs 63 and 163.	Default: 0 Range: 0 to FFFFH	–

H2 Multi-Function Digital Output Settings

H2-□□ Setting	Function	LCD Display	Description	Page
0	During run	During RUN 1	Closed: A Run command is active or voltage is output.	–
1	Zero speed	Zero Speed	Open: Output speed is greater than or equal to the value of E1-09 (Minimum Output Frequency) or b2-01 (DC Injection Braking Start Frequency). Closed: Output frequency is less than the value of E1-09 (Minimum Output Frequency) or b2-01 (DC Injection Braking Start Frequency).	–
2	Speed agree 1	Fref/Fout Agree1	Closed: Output frequency equals the speed reference (plus or minus the hysteresis set to L4-02).	–
3	User-set speed agree 1	Fref/Set Agree 1	Closed: Output frequency and speed reference equal L4-01 (plus or minus the hysteresis set to L4-02).	–
4	Frequency detection 1	Freq Detect 1	Closed: Output frequency is less than or equal to the value in L4-01 with hysteresis determined by L4-02.	–
5	Frequency detection 2	Freq Detect 2	Closed: Output frequency is greater than or equal to the value in L4-01 with hysteresis determined by L4-02.	–
6	Drive ready	Drive Ready	Closed: Power up is complete and the drive is ready to accept a Run command.	–
7	During Power Supply Voltage Fault	DC Bus Undervolt	Closed: One of the following faults will occur: AUv (Power Supply Undervoltage), Uv (Undervoltage). or Fdv (Power Supply Frequency Fault).	–
8	During baseblock (N.O.)	BaseBlk 1	Closed: Drive has entered the baseblock state (no output voltage).	–
9	Frequency reference source	Ref Source	Open: External Reference 1 or 2 supplies the frequency reference (set in b1-01 or b1-15). Closed: Digital operator supplies the frequency reference.	–
A	HAND Mode	Hand Mode	Closed: Pump is in HAND Mode operation.	–
B	Torque detection 1 (N.O.)	Trq Det 1 N.O.	Closed: An overtorque or undertorque situation has been detected.	–
C	Frequency reference loss	Loss of Ref	Closed: Analog frequency reference has been lost. Frequency reference loss is detected when the frequency reference drops below 10% of the reference within 400 ms.	–
E	Fault	Fault	Closed: Fault occurred (this excludes CPF00 and CPF01).	–
F	Through mode	Not Used	Select this setting when the terminal is not used or when using the terminal in the pass-through mode.	–
10	Minor fault	Minor Fault	Closed: An alarm has been triggered.	–
11	Fault reset command active	Reset Cmd Active	Closed: The drive has received a reset command from the multi-function input terminals or from a serial network, or the RESET key on the digital operator has been pressed.	–
12	Timer output	Timer Output	Closed: Timer output.	–
13	Speed agree 2	Fref/Fout Agree2	Closed: When drive output frequency equals the frequency reference ±L4-04.	–

B.8 H Parameters: Multi-Function Terminals

H2 Multi-Function Digital Output Settings				
H2-□□ Setting	Function	LCD Display	Description	Page
14	User-set speed agree 2	Fref/Set Agree 2	Closed: When the drive output frequency is equal to the value in L4-03 ±L4-04.	–
15	Frequency detection 3	Freq Detect 3	Closed: When the drive output frequency is less than or equal to the value in L4-03 ±L4-04.	–
16	Frequency detection 4	Freq Detect 4	Closed: When the output frequency is greater than or equal to the value in L4-03 ±L4-04.	–
17	Torque detection 1 (N.C.)	Trq Det 1 N.C.	Open: Overtorque or undertorque has been detected.	–
18	Torque detection 2 (N.O.)	Trq Det 2 N.O.	Closed: Overtorque or undertorque has been detected.	
19	Torque detection 2 (N.C.)	Trq Det 2 N.C.	Open: Overtorque or undertorque has been detected.	–
1A	During reverse	Reverse Dir	Closed: Drive is running in the reverse direction.	–
1B	During baseblock (N.C.)	BaseBlk 2	Open: Drive has entered the baseblock state (no output voltage).	–
1E	Restart enabled	Dur Flt Restart	Closed: An automatic restart is performed	–
1F	Motor overload alarm (oL1)	Overload (OL1)	Closed: oL1 is at 90% of its trip point or greater. An oH3 situation also triggers this alarm.	–
20	Drive overheat pre-alarm (oH)	OH Prealarm	Closed: Heatsink temperature exceeds the parameter L8-02 value.	–
2F	Maintenance period	Maintenance	Closed: Cooling fan, capacitor for the control power supply, or the soft charge bypass relay may require maintenance.	–
30	During torque limit	Torque Limit	OLV Closed: When the torque limit has been reached.	–
37	During frequency output	During RUN 2	Open: No frequency output from drive if stopped with baseblock or DC injection braking during initial excitation. Closed: Drive is outputting a frequency.	–
38	Drive enabled	Drive Enable	Closed: Multi-function input set for “Drive enable” is closed (H1-□□ = 6A)	–
39	Power Consumption Pulse Output	Energy Pulse Out	Outputs a pulse to indicate the power consumption. Output units are determined by H2-06. Outputs a pulse every 200 ms to indicate the kWh count.	–
3A	Regenerated Power Pulse Output	RegEn Pulse Out	Outputs a pulse to indicate the regenerated power. Output units are determined by H2-06. Outputs a pulse every 200 ms to indicate the kWh count.	–
3D	During speed search	During SpdSrch	Closed: Speed Search is being executed.	–
3E	PID feedback low	PID Feedback Low	Closed: PID feedback level is too low.	–
3F	PID feedback high	PID FeedbackHigh	Closed: The PID feedback level is too high.	–
40	AUTO Mode	Auto Mode	Closed: Pump is in AUTO Mode operation.	–
42	Pressure Reached	Pressure Reached	Pressure Setpoint has been reached. Activation and deactivation conditions based on the Pressure Feedback and the settings of P4-36 to P4-40.	–
43	2 Motor Alternate	2Motor Alternate	Used in conjunction with the 2-motor alternation function. Open: Motor 1 in use. (or 2-motor alternation is disabled) Closed: Motor 2 in use.	–
4C	During fast stop	During Fast Stop	Closed: A Fast Stop command has been entered from the operator or input terminals.	–
4D	oH Pre-alarm time limit	OH Pre-Alarm	Closed: oH pre-alarm time limit has passed.	–
51	Sequence timer 1	Sequence Timer 1	Closed: Sequence timer 1 is active.	–
52	Sequence timer 2	Sequence Timer 2	Closed: Sequence timer 2 is active.	–
53	Sequence timer 3	Sequence Timer 3	Closed: Sequence timer 3 is active.	–
54	Sequence timer 4	Sequence Timer 4	Closed: Sequence timer 4 is active.	–
58	Underload detection	UL6	Closed: Underload is detected.	–
60	Internal cooling fan alarm	Fan Alm Det	Closed: Internal cooling fan alarm	–
62	MEMOBUS Register 1 (Selected with H2-07 and H2-08)	Memobus Regs1	The contact output is closed when any of the bits specified by H2-08 for the MEMOBUS/Modbus register address set in H2-07 turn on.	–
63	MEMOBUS Register 2 (Selected with H2-09 and H2-10)	Memobus Regs2	The contact output is closed when any of the bits specified by H2-10 for the MEMOBUS/Modbus register address set in H2-09 turn on.	–

H2 Multi-Function Digital Output Settings				
H2-□□ Setting	Function	LCD Display	Description	Page
64	During Commercial Power Operation	CommerclPwr Mode	Closed: Operating on commercial power.	–
80	Pump 2 Control	Pump 2 Control	Contactora control for a second pump. The function is active in contactor multiplex mode only (P1-01 = 1).	–
81	Pump 3 Control	Pump 3 Control	Contactora control for a third pump. The function is active in contactor multiplex mode only (P1-01 = 1) and when P3-01 is set to a value greater than 1.	–
82	Pump 4 Control	Pump 4 Control	Contactora control for a fourth pump. The function is active in contactor multiplex mode only (P1-01 = 1) and when P3-01 is set to a value greater than 2.	–
83	Pump 5 Control	Pump 5 Control	Contactora control for a fifth pump. The function is active in contactor multiplex mode only (P1-01 = 1) and when P3-01 is set to a value greater than 3.	–
84	Pump 6 Control	Pump 6 Control	Contactora control for a sixth pump. The function is active in contactor multiplex mode only (P1-01 = 1) and when P3-01 is set to a value greater than 4.	–
89	Output I Limit	Output I Lim	Closed: Drive output speed is being limited due to the output current limit or the single phase foldback regulator.	–
8B	Lube Pump or Digital Output Delay	Lube Pump or DigitalOutput Delay	Closed: Refer to Lube Pump / Digital Output Delay parameters P4-30 and P4-31. Display text is set by parameter P4-29.	–
8F	Internal Fan On	Internal Fan On	Internal Fan On	–
91	Pump Fault	Pump Fault	Closed when any of the following faults are active: <ul style="list-style-type: none"> • Low feedback • High feedback • Low water • High water • NMS-Setpoint not met • POC-Pump over cycle • External pump fault 	–
92	Transducer Loss	Transducer Loss	Closed: The analog output associated with PID feedback has risen above 21 mA or fallen below 3 mA or a Transducer Loss alarm or fault is active.	–
93	Setpoint Not Met	SetPoint Not Met	Closed: During an “NMS-Setpoint Not Met” condition.	–
94	Loss of Prime	Loss of Prime	Closed: During an “LOP-Loss of Prime” condition.	–
95	Volute Thermostat Fault	Volute-TStat Flt	Closed: Volute-Thermostat digital input is active.	–
96	High Feedback	High Feedback	Closed: During a “High Feedback” condition as defined by P1-11 and P1-12 OR Closed: During a “High FB/Water” fault OR Closed: During a “High Feedback” alarm	–
97	Low Feedback	Low Feedback	Closed: During a “Low Feedback” condition as defined by P1-08 and P1-12 OR Closed: During a “Low FB/Water” fault OR Closed: During a “Low Feedback” alarm	–
98	Low Flow	Low Flow	Closed: During the “Low Flow Fault” condition OR Closed: During a Low Flow condition set by P6-06 to P6-08, including a “Low Flow” alarm	–
99	Accum Level	Accum Level	Closed: Accumulated level has exceeded the P6-11 to P6-14 settings OR Closed: During the “Accum Level” fault	–
9A	High Flow	High Flow	Closed: During the “High Flow Fault” condition OR Closed: During a “High Flow” condition set by P6-17 and P6-18, including a “High Flow” alarm	–
9B	Low Water Level	Low Water Level	Closed: The water level has dropped below the Low Detection Level set in Q4-09.	–
9C	Low Suction	Low Suction	Closed: The suction pressure has dropped below the Low Suction Pressure Detection Level set in Q5-09.	–
9D	High Suction	High Suction	Closed: The suction pressure has risen above the High Suction Pressure Detection Level set in Q5-12.	–
9E	Low PI Aux Level	Low PI Aux Lvl	Energizes when the PI Aux Feedback Level drops below the Low PI Aux Level (Q6-09), or if there is a LOAUX – Low PI Aux Level Fault.	–
9F	High PI Aux Level	High PI Aux Lvl	Energizes when the PI Aux Feedback Level rises above the High PI Aux Level (Q6-12), or if there is a HIAUX – Hi PI Aux Lvl Fault.	–

B.8 H Parameters: Multi-Function Terminals

H2 Multi-Function Digital Output Settings				
H2-□□ Setting	Function	LCD Display	Description	Page
A0	Water Loss/Suction Pressure/PI Aux Control	WL/SP/PIAux Ctrl	Closed when the Water Level, Suction Pressure, or PI Auxiliary Controller is affecting the output speed.	–
A1	Differential Detected	Differential Det	Closed: The difference between the PID Feedback and the Differential Feedback (H3-□□ = 28) exceeded the P4-18 level for the time set in P4-19.	–
A2	Sleep Active	Sleep Active	Closed: The drive is not running due to the Sleep function (does not include Sleep Boost).	–
A3	Start Delay	Start Delay	Closed: Feedback has risen above the start level (or fallen below for Inverse PID) and the start timer is timing.	–
A4	Pre-Charge	Pre-Chg Active	Closed: Drive is in Pre-Charge mode.	–
A5	Anti-Jam Active	Anti-Jam Active	Closed: The anti-jam function is active (configured by P7-□□).	–
A6	De-Scale Active	De-Scale Active	Closed: De-scale is running.	–
A7	Flow Rate Limit	Flow Rate Limit	Closed: The Flow Rate is actively affecting the output speed.	–
A9	Thrust Mode	Thrust Mode	Closed: The Thrust Bearing feature is active (output frequency is between 0 and the value of P4-12).	–
AA	Utility Start Delay	Utility Delay	Closed: The drive is stopped and waiting for the utility delay timer set in P4-17 to expire.	–
AB	Main Feedback Lost	Main FdBk Lost	Closed: Main feedback is lost.	–
AC	Backup Feedback Lost	Backup FdBk Lost	Closed: Backup feedback is lost.	–
100 to 1AC	Function 0 to AC with inverse output	!Function	Inverts the output switching of the multi-function output functions. Set the last two digits of 1□□ to reverse the output signal of that specific function.	–

◆ H3: Multi-Function Analog Inputs

No. (Addr. Hex)	Name	LCD Display	Description	Values	Page
H3-01 (0410)	Terminal A1 Signal Level Selection	Term A1 Level 0: 0-10V, (LowLim=0) 1: 0-10V, (BipolRef) 2: 4-20 mA 3: 0-20 mA	0: 0 to 10 V 1: -10 to 10 V 2: 4 to 20 mA 3: 0 to 20 mA Note: Use Jumper S1 to set input terminal A1 for a current or voltage input signal.	Default: 0 Range: 0 to 3	178
H3-02 (0434)	Terminal A1 Function Selection	Term A1 FuncSel	Sets the function of terminal A1.	Default: 0 Range: 0 to 28	178
H3-03 (0411) [RUN]	Terminal A1 Gain Setting	Terminal A1 Gain	Sets the level of the input value selected in H3-02 when 10 V is input at terminal A1.	Default: 100.0% Min.: -999.9 Max.: 999.9	179
H3-04 (0412) [RUN]	Terminal A1 Bias Setting	Terminal A1 Bias	Sets the level of the input value selected in H3-02 when 0 V is input at terminal A1.	Default: 0.0% Min.: -999.9 Max.: 999.9	179
H3-05 (0413)	Terminal A3 Signal Level Selection	Term A3 Signal 0: 0-10V (LowLim=0) 1: 0-10V, (BipolRef) 2: 4-20 mA 3: 0-20 mA	0: 0 to 10 V 1: -10 to 10 V 2: 4 to 20 mA 3: 0 to 20 mA Note: Use Jumper S1 to set input terminal A3 for a current or voltage input signal.	Default: 0 Range: 0 to 3	179
H3-06 (0414)	Terminal A3 Function Selection	Terminal A3 Sel	Sets the function of terminal A3.	Default: 20 Range: 0 to 28	179
H3-07 (0415) [RUN]	Terminal A3 Gain Setting	Terminal A3 Gain	Sets the level of the input value selected in H3-06 when 10 V is input at terminal A3.	Default: 100.0% Min.: -999.9 Max.: 999.9	180
H3-08 (0416) [RUN]	Terminal A3 Bias Setting	Terminal A3 Bias	Sets the level of the input value selected in H3-06 when 0 V is input at terminal A3.	Default: 0.0% Min.: -999.9 Max.: 999.9	180

No. (Addr. Hex)	Name	LCD Display	Description	Values	Page
H3-09 (0417)	Terminal A2 Signal Level Selection	Term A2 Level	0: 0 to 10 V 1: -10 to 10 V 2: 4 to 20 mA 3: 0 to 20 mA Note: Use DIP switch S1 to set input terminal A2 for a current or a voltage input signal.	Default: 2 Range: 0 to 3	180
H3-10 (0418)	Terminal A2 Function Selection	Term A2 FuncSel	Sets the function of terminal A2.	Default: B Range: 0 to 28	180
H3-11 (0419) [RUN]	Terminal A2 Gain Setting	Terminal A2 Gain	Sets the level of the input value selected in H3-10 when 10 V (20 mA) is input at terminal A2.	Default: 100.0% Min.: -999.9 Max.: 999.9	180
H3-12 (041A) [RUN]	Terminal A2 Bias Setting	Terminal A2 Bias	Sets the level of the input value selected in H3-10 when 0 V (0 or 4 mA) is input at terminal A2.	Default: 0.0% Min.: -999.9 Max.: 999.9	180
H3-13 (041B)	Analog Input Filter Time Constant	A1/A2 Filter T	Sets a primary delay filter time constant for terminals A1, A2, and A3. Used for noise filtering.	Default: 0.03 s Min.: 0.00 Max.: 2.00	–
H3-14 (041C)	Analog Input Terminal Enable Selection	A1/A2/A3 Sel 1: A1 Available 2: A2 Available 3: A1/A2 Available 4: A3 Available 5: A1/A3 Available 6: A2/A3 Available 7: All Available	Determines which analog input terminals will be enabled or disabled when a digital input programmed for “Analog input enable” (H1-□□ = C) is activated. The terminals not set as the target are not influenced by input signals. 1: Terminal A1 only 2: Terminal A2 only 3: Terminals A1 and A2 only 4: Terminal A3 only 5: Terminals A1 and A3 6: Terminals A2 and A3 7: All terminals enabled	Default: 7 Range: 1 to 7	–
H3-16 (02F0)	Terminal A1 Offset	TerminalA1Offset	Adds an offset when the analog signal to terminal A1 is at 0 V.	Default: 0 Min.: -500 Max.: 500	–
H3-17 (02F1)	Terminal A2 Offset	TerminalA2Offset	Adds an offset when the analog signal to terminal A2 is at 0 V.	Default: 0 Min.: -500 Max.: 500	–
H3-18 (02F2)	Terminal A3 Offset	TerminalA3Offset	Adds an offset when the analog signal to terminal A3 is at 0 V.	Default: 0 Min.: -500 Max.: 500	–

H3 Multi-Function Analog Input Settings

H3-□□ Setting	Function	LCD Display	Description When Output Is 100%	Page
0	Frequency bias	Freq Ref Bias	E1-04 (maximum output frequency)	–
1	Frequency gain	Freq Ref Gain	0 to 10 V signal allows a setting of 0 to 100%. -10 to 0 V signal allows a setting of -100 to 0%.	–
2	Auxiliary frequency reference 1	Aux Reference1	E1-04 (maximum output frequency)	–
3	Auxiliary frequency reference 2	Aux Reference2	E1-04 (maximum output frequency)	–
4	Output voltage bias	Voltage Bias	10 V = E1-05 (motor rated voltage)	–
5	Accel/decel time gain	Acc/DecTime Gain	10 V = 100%	–
6	DC Injection Braking current	DC Brake Current	10 V = Drive rated current	–
7	Torque detection level	Torque Det Level	10 V = Drive rated current (V/f) 10 V = Motor rated torque (OLV)	–
8	Stall Prevention level during run	Stall Prev Level	10 V = Drive rated current	–
9	Output frequency lower limit level	Ref Lower Limit	10 V = E1-04 (maximum output frequency)	–
B	PID feedback	PID Feedback1	10 V = 100%	–
C	PID setpoint	PID Set Point	10 V = 100%	–

B.8 H Parameters: Multi-Function Terminals

H3 Multi-Function Analog Input Settings				
H3-□□ Setting	Function	LCD Display	Description When Output Is 100%	Page
D	Frequency bias	Freq Ref Bias 2	10 V = E1-04 (maximum output frequency)	–
E	Motor temperature (PTC input)	Motor PTC	10 V = 100%	–
F	Through mode	Not Used	Select this setting when the terminal is not used or when using the terminal in the pass-through mode.	–
10	Forward torque limit	Fwd Torque Limit	OLV 10 V = Motor rated torque	–
11	Reverse torque limit	Rev Torque Limit	OLV 10 V = Motor rated torque	–
12	Regenerative torque limit	Regen Torq Limit	OLV 10 V = Motor rated torque	–
13	Torque reference/ Torque limit	Torque Reference	OLV 10 V = Motor rated torque	–
14	Torque compensation	Torque Comp	OLV 10 V = Motor rated torque	–
15	General torque limit	Torque Limit	OLV 10 V = Motor rated torque	–
16	Differential PID feedback	PID Feedback 2	10 V = 100%	–
1F	Through mode	Not Used	Select this setting when the terminal is not used or when using the terminal in the pass-through mode.	–
20	HAND Frequency Reference	Hand Freq. Ref.	Full scale: Maximum frequency (E1-04)	–
22	Flow Meter	Flow Meter	Full scale: P6-01	–
23	Water Level or Suction Input	WaterLvl/Suction	When Water Level Control is enabled (Q4-01 = 1): 0 V or 4 mA = 0 (ft) 10 V or 20 mA = Q4-02 (PSI) * 2.308 ft/PSI OR When Suction Pressure Control is enabled (Q5-01 = 1) <1> 0 V or 4 mA = 9 (PSI) 10 V or 20 mA = Q5-02 (PSI) OR When Vacuum Control is enabled (Q5-01 = 2) <2> 0 V or 4 mA = 0 ("Hg) 10 V or 20 mA = Q5-02 ("Hg)	–
24	PI Feedback Backup	PI FdBack Backup	Full scale: FB Device Scaling (P1-03)	–
27	PI Auxiliary Feedback Level	PI Aux FB Level	0 V or 4 mA = 0 (unit based on Q6-22) 10 V or 20 mA = Q6-02 (unit based on Q6-22)	–
28	Differential PI Feedback	Diff PI Feedback	Full scale: FB Device Scaling (P1-03)	–

<1> When Pressure Control is enabled (Q5-01 = 1), the action of the analog input is normal. A higher voltage or current on the input causes a higher pressure to be read in the drive.

<2> When Vacuum Control is enabled (Q5-01 = 2), the action of the analog input is reversed. A higher voltage or current on the input causes a lower pressure (or higher level of vacuum) to be read in the drive.

◆ H4: Analog Outputs

No. (Addr. Hex)	Name	LCD Display	Description	Values	Page
H4-01 (041D)	Multi-Function Analog Output Terminal FM Monitor Selection	Term FM FuncSel	Selects the data to be output through multi-function analog output terminal FM. Set the desired monitor parameter to the digits available in U□-□□. For example, enter "103" for U1-03.	Default: 102 Range: 000 to 999	181
H4-02 (041E) RUN	Multi-Function Analog Output Terminal FM Gain	Terminal FM Gain	Sets the signal level at terminal FM that is equal to 100% of the selected monitor value.	Default: 100.0% Min.: -999.9 Max.: 999.9	181

No. (Addr. Hex)	Name	LCD Display	Description	Values	Page
H4-03 (041F) [RUN]	Multi-Function Analog Output Terminal FM Bias	Terminal FM Bias	Sets the signal level at terminal FM that is equal to 0% of the selected monitor value.	Default: 0.0% Min.: -999.9 Max.: 999.9	181
H4-04 (0420)	Multi-Function Analog Output Terminal AM Monitor Selection	Terminal AM Sel	Selects the data to be output through multi-function analog output terminal AM. Set the desired monitor parameter to the digits available in U□-□□. For example, enter “103” for U1-03.	Default: 103 Range: 000 to 999	181
H4-05 (0421) [RUN]	Multi-Function Analog Output Terminal AM Gain	Terminal AM Gain	Sets the signal level at terminal AM that is equal to 100% of the selected monitor value.	Default: 50.0% Min.: -999.9 Max.: 999.9	181
H4-06 (0422) [RUN]	Multi-Function Analog Output Terminal AM Bias	Terminal AM Bias	Sets the signal level at terminal AM that is equal to 0% of the selected monitor value.	Default: 0.0% Min.: -999.9 Max.: 999.9	181
H4-07 (0423)	Multi-Function Analog Output Terminal FM Signal Level Selection	Term FM Lvl Sel 0: 0-10 VDC 1: -10 +10 VDC 2: 4-20 mA	0: 0 to 10 V 1: -10 to 10 V 2: 4 to 20 mA	Default: 0 Range: 0 to 2	182
H4-08 (0424)	Multi-Function Analog Output Terminal AM Signal Level Selection	Term AM Lvl Sel 0: 0-10 VDC 1: -10 +10 VDC 2: 4-20 mA	0: 0 to 10 V 1: -10 to 10 V 2: 4 to 20 mA	Default: 0 Range: 0 to 2	182

◆ H5: MEMOBUS/Modbus Serial Communication

Note: Restart the drive to enable MEMOBUS/Modbus communication settings.

No. (Addr. Hex)	Name	LCD Display	Description	Values	Page
H5-01 (0425) </>	Drive Node Address	Serial Comm Adr	Selects drive station node number (address) for MEMOBUS/Modbus terminals R+, R-, S+, S-. Cycle power for the setting to take effect.	Default: 1F (Hex) Min.: 0 Max.: FFH	-
H5-02 (0426)	Communication Speed Selection	Serial Baud Rate 0: 1200 bps 1: 2400 bps 2: 4800 bps 3: 9600 bps 4: 19.2 kbps 5: 38.4 kbps 6: 57.6 kbps 7: 76.8 kbps 8: 115.2 kbps	0: 1200 bps 1: 2400 bps 2: 4800 bps 3: 9600 bps 4: 19200 bps 5: 38400 bps 6: 57600 bps 7: 76800 bps 8: 115200 bps Note: Cycle power for the setting to take effect.	Default: 3 Range: 0 to 8	-
H5-03 (0427)	Communication Parity Selection	Serial Com Sel 0: No Parity 1: Even Parity 2: Odd Parity	0: No parity 1: Even parity 2: Odd parity Note: Cycle power for the setting to take effect.	Default: 0 Range: 0 to 2	-
H5-04 (0428)	Stopping Method after Communication Error (CE)	Serial Fault Sel 0: Ramp to Stop 1: Coast to Stop 2: Fast-Stop 3: Alarm Only 4: Run at H5-14	0: Ramp to stop 1: Coast to stop 2: Fast Stop 3: Alarm only 4: Run at H5-14	Default: 3 Range: 0 to 4	-
H5-05 (0429)	Communication Fault Detection Selection	Serial Flt Dtct 0: Disabled 1: Enabled	0: Disabled 1: Enabled. If communication is lost for more than two seconds, a CE fault will occur.	Default: 1 Range: 0, 1	-
H5-06 (042A)	Drive Transmit Wait Time	Transmit WaitTIM	Set the wait time between receiving and sending data. Note: Cycle power for the setting to take effect.	Default: 5 ms Min.: 5 Max.: 65	-
H5-07 (042B)	RTS Control Selection	RTS Control Sel 0: Disabled 1: Enabled	0: Disabled. RTS is always on. 1: Enabled. RTS turns on only when sending. Note: Cycle power for the setting to take effect.	Default: 1 Range: 0, 1	-

B.8 H Parameters: Multi-Function Terminals

No. (Addr. Hex)	Name	LCD Display	Description	Values	Page
H5-09 (0435)	Communication Fault Detection Time	CE Detect Time	Sets the time required to detect a communications error. Adjustment may be needed when networking several drives.	Default: 2.0 s Min.: 0.0 Max.: 10.0	–
H5-10 (0436)	Unit Selection for MEMOBUS/Modbus Register 0025H	CommReg 25h Unit 0: 0.1 V 1: 1 V	0: 0.1 V units 1: 1 V units	Default: 0 Range: 0, 1	–
H5-11 (043C)	Communications ENTER Function Selection	Enter CommandSel 0: Enter Required 1: No EnterRequired	0: Drive requires an Enter command before accepting any changes to parameter settings. 1: Parameter changes are activated immediately without the Enter command (same as V7).	Default: 0 Range: 0, 1	–
H5-12 (043D)	Run Command Method Selection	Run CommandSel 0: FWD Run & REV Run 1: Run & FWD/REV	0: FWD/Stop, REV/Stop 1: Run/Stop, FWD/REV	Default: 0 Range: 0, 1	–
H5-13 (043E)	Power-up CALL Alarm	Powr-up CALL Alm 0: Disabled 1: Enabled	Determines whether a CALL alarm is triggered at power-up when communication with the external controller has not been established. 0: Disabled 1: Enabled	Default: 0 Range: 0, 1	–
H5-14 (0FB4) <input type="checkbox"/> RUN	Communication Error (CE) Go-To- Frequency	CE Go-To-Freq	Sets the speed at which the drive will run when H5-04 is set to 4 (Run at H5-14) and a CE error is present.	Default: 0.0 Hz Min.: 0.0 Max.: 400.0	–
H5-15 (0FB5) <input type="checkbox"/> RUN	Communication Error (CE) Go-To-Timeout	CE Go-To-Timeout	Sets the amount of time that the drive will run at the speed set in H5-14 before triggering a CE fault when H5-04 is set to 4 (Run at H5-14) and a CE error is present. Setting this parameter to 0 will disable the time-out.	Default: 0 s Min.: 0 Max.: 6000	–
H5-16 (0FB6)	Communication Error Fault Restart Selection	CE Fault Restart 0: No Retry 1: Retry	Determines whether the CE fault can be restarted (L5-01). 0: No Retry 1: Retry	Default: 0 Range: 0, 1	–
H5-17 (11A1)	Operation Selection when Unable to Write into EEPROM	Busy Enter Sel 0: No ROM Enter 1: RAM Enter	Selects operation when an attempt is made to write data into EEPROM via MEMOBUS/Modbus communications and writing into EEPROM is not possible. There is normally no need to change this parameter from the default value 0: Cannot write into EEPROM 1: Write in RAM only	Default: 0 Range: 0, 1	–
H5-18 (11A2)	Filter Time Constant for Motor Speed Monitoring	MtrSpd Monitor T	Sets the filter time constant for monitoring the motor speed from MEMOBUS/Modbus communications and communication options. Applicable MEMOBUS/Modbus registers are: 3EH, 3FH, 44H, ACH, and ADH	Default: 0 ms Min.: 0 Max.: 100	–

<1> If this parameter is set to 0, the drive will be unable to respond to MEMOBUS/Modbus commands.

◆ H6: Pulse Train Input

No. (Addr. Hex)	Name	LCD Display	Description	Values	Page
H6-01 (042C)	Pulse Train Input Terminal RP Function Selection	Term RP Func Sel 0: Frequency Ref 1: PID Feedback 2: PID Set Point 5: Flow Meter	0: Frequency reference 1: PID feedback value 2: PID setpoint value 5: Flow meter Note: When this parameter is set to 5, parameters H6-02 to H6-04 and H6-08 are ignored.	Default: 0 Range: 0 to 2; 5	–
H6-02 (042D) <input type="checkbox"/> RUN	Pulse Train Input Scaling	Term RP Scaling	Sets the terminal RP input signal frequency that is equal to 100% of the value selected in H6-01.	Default: 1440 Hz Min.: 100 Max.: 32000	–
H6-03 (042E) <input type="checkbox"/> RUN	Pulse Train Input Gain	Terminal RP Gain	Sets the level of the value selected in H6-01 when a frequency with the value set in H6-02 is input.	Default: 100.0% Min.: 0.0 Max.: 1000.0	–

No. (Addr. Hex)	Name	LCD Display	Description	Values	Page
H6-04 (042F) [RUN]	Pulse Train Input Bias	Terminal RP Bias	Sets the level of the value selected in H6-01 when 0 Hz is input.	Default: 0.0% Min.: -100.0 Max.: 100.0	–
H6-05 (0430) [RUN]	Pulse Train Input Filter Time	Term RP Flt Time	Sets the pulse train input filter time constant.	Default: 0.50 s Min.: 0.00 Max.: 2.00	–
H6-08 (043F)	Pulse Train Input Minimum Frequency	RP Lower Limit	Sets the minimum frequency for the pulse train input to be detected. Enabled when H6-01 = 0, 1, or 2.	Default: 0.5 Hz Min.: 0.1 Max.: 1000.0	–

B.9 L: Protection Function

L parameters provide protection to the drive and motor, including control during momentary power loss, stall prevention, frequency detection, fault restarts, overtorque and undertorque detection, and other types of hardware protection.

◆ L1: Motor Protection

No. (Addr. Hex)	Name	LCD Display	Description	Values	Page
L1-01 (0480)	Motor Overload Protection Selection	Mtr OL Charact 0: OL1 Disabled 1: VT Motor 2: CT Motor 3: Vector Motor 6: 50Hz VT Motor	0: Disabled 1: General purpose motor (standard fan cooled) 2: Drive dedicated motor with a speed range of 1:10 3: Vector motor with a speed range of 1:100 6: General purpose motor (50 Hz) The drive may not be able to provide protection when using multiple motors, even if overload is enabled in L1-01. Set L1-01 to 0 and install separate thermal relays to each motor.	Default: </> Range: 0 to 3; 6	–
L1-02 (0481)	Motor Overload Protection Time	MOL Time Const	Sets the motor thermal overload protection (oL1) time.	Default: 1.0 min Min.: 0.1 Max.: 5.0	–
L1-03 (0482)	Motor Overheat Alarm Operation Selection (PTC input)	Mtr OH Alarm Sel 0 : Ramp to Stop 1: Coast to Stop 2: Fast-Stop 3: Alarm only	Sets operation when the motor temperature analog input (H3-02, H3-10, or H3-06 = E) exceeds the oH3 alarm level. 0: Ramp to stop 1: Coast to stop 2: Fast Stop (decelerate to stop using the deceleration time in C1-09) 3: Alarm only (“oH3” will flash)	Default: 3 Range: 0 to 3	–
L1-04 (0483)	Motor Overheat Fault Operation Selection (PTC input)	Mtr OH Fault Sel 0 : Ramp to Stop 1: Coast to Stop 2: Fast-Stop	Sets stopping method when the motor temperature analog input (H3-02, H3-10, or H3-06 = E) exceeds the oH4 fault level. 0: Ramp to stop 1: Coast to stop 2: Fast Stop (decelerate to stop using the deceleration time in C1-09)	Default: 1 Range: 0 to 2	–
L1-05 (0484)	Motor Temperature Input Filter Time (PTC input)	Mtr Temp Filter	Adjusts the filter for the motor temperature analog input (H3-02, H3-10, or H3-06 = E).	Default: 0.20 s Min.: 0.00 Max.: 10.00	–
L1-13 (046D)	Continuous Electrothermal Operation Selection	Mtr OL Mem Sel 0: Disabled 1: Enabled 2: Enabled(RTC)	0: Disabled 1: Enabled 2: Enabled (RTC)	Default: 1 Range: 0 to 2	–

</> Default setting is determined by parameter A1-02, Control Method Selection.

◆ L2: Momentary Power Loss Ride-Thru

No. (Addr. Hex)	Name	LCD Display	Description	Values	Page
L2-01 (0485)	Momentary Power Loss Operation Selection	PwrL Selection 0: Disabled 1: Enbl with Timer 2: Enbl whl CPU act	0: Disabled. Drive trips on Uv1 fault when power is lost. 1: Recover within the time set in L2-02. Uv1 will be detected if power loss is longer than L2-02. 2: Recover as long as CPU has power. Uv1 is not detected.	Default: 2 Range: 0 to 2	–
L2-02 (0486)	Momentary Power Loss Ride-Thru Time	PwrL Ridethru t	Sets the Power Loss Ride-Thru time. Enabled only when L2-01 = 1 or 2.	Default: 0.5 s Min.: 0.0 Max.: 2.5	–
L2-03 (0487)	Momentary Power Loss Minimum Baseblock Time	PwrL Baseblock t	Sets the minimum wait time for residual motor voltage decay before the drive output reenergizes after performing Power Loss Ride-Thru. Increasing the time set to L2-03 may help if overcurrent or overvoltage occur during Speed Search or during DC Injection Braking.	Default: </> Min.: 0.1 s Max.: 5.0 s	–
L2-04 (0488)	Momentary Power Loss Voltage Recovery Ramp Time	PwrL V/F Ramp t	Sets the time for the output voltage to return to the preset V/f pattern during Speed Search.	Default: </> Min.: 0.0 s Max.: 5.0 s	–

No. (Addr. Hex)	Name	LCD Display	Description	Values	Page
L2-07 (048B)	Momentary Power Loss Voltage Recovery Acceleration Time	KEB Accel Time	Sets the time to accelerate to the frequency reference when momentary power loss is over. If set to 0.0, the active acceleration time (C1-01, C1-03, C1-05) is used.	Default: 0.00 s Min.: 0.00 Max.: 6000.0 <2>	-
L2-13 (04CD)	Input Power Frequency Fault Detection Gain	FDV Detect Gain	Set the gain to use to detect power supply frequency fault (Fdv).	Default: 1.0 Min.: 0.1 Max.: 2.0	-
L2-21 (04D5)	Low Input Voltage Detection Level	AVV Detect Level	Set the level at which to detect a low input voltage.	Default: 150 V Min.: 100 V <3> Max.: 230 V <3>	-
L2-27 (04F7)	Power Supply Frequency Fault Detection Width	FDV Detect Width	Sets the frequency width to use to detect power supply frequency fault (Fdv).	Default: 6.0 Hz Min.: 3.0 Hz Max.: 20.0 Hz	-

<1> Default setting is determined by parameter o2-04, Drive Model Selection.

<2> Setting range value is dependent on parameter C1-10, Accel/Decel Time Setting Units. When C1-10 = 0 (units of 0.01 seconds), the setting range becomes 0.00 to 600.00 seconds.

<3> Values shown are specific to 200 V class drives. Double the value for 400 V class drives.

◆ L3: Stall Prevention

No. (Addr. Hex)	Name	LCD Display	Description	Values	Page
L3-01 (048F)	Stall Prevention Selection during Acceleration	StallP Accel Sel 0: Disabled 1: General Purpose 3: iLim Mode	0: Disabled. 1: Enabled. General purpose. Acceleration is paused as long as the current is above the L3-02 setting. 3: Enabled (Current Limit). The acceleration rate is automatically adjusted while limiting the output current at the setting value of the stall prevention level (L3-02).	Default: 1 Range: 0, 1, 3	-
L3-02 (0490)	Stall Prevention Level during Acceleration	StallP Accel Lvl	Used when L3-01 = 1 or 3. 100% is equal to the drive rated current.	Default: <1> Min.: 0% Max.: 150% <1>	-
L3-03 (0491)	Stall Prevention Limit during Acceleration/Deceleration	StallPAcc LowLim	Sets Stall Prevention lower limit during acceleration/deceleration when operating in the constant power range. Set as a percentage of drive rated current.	Default: 50% Min.: 0 Max.: 100	-
L3-04 (0492)	Stall Prevention Selection during Deceleration	StallP Decel Sel 0: Disabled 1: General Purpose 4: High Flux Brake 6: iLim Mode	0: Disabled. Deceleration at the active deceleration rate. An ov fault may occur. 1: General purpose. Deceleration is paused when the output current exceeds the Stall Prevention level. 4: Overexcitation Deceleration. Decelerates while increasing the motor flux. 6: Enable (Current Limit). The deceleration rate is automatically adjusted while limiting the regeneration current at the setting value of the stall prevention level (L3-14).	Default: 0 Range: 0 to 6	-
L3-05 (0493)	Stall Prevention Selection during Run	StallP Run Sel 0: Disabled 1: Decel Time 1 2: Decel Time 2	0: Disabled. Drive runs at a set frequency. A heavy load may cause stalling. 1: Decel time 1. Uses the deceleration time set to C1-02 while Stall Prevention is performed. 2: Decel time 2. Uses the deceleration time set to C1-04 while Stall Prevention is performed.	Default: 0 Range: 0 to 2	-
L3-06 (0494)	Stall Prevention Level during Run	StallP Run Level	Enabled when L3-05 is set to 1 or 2. 100% is equal to the drive rated current.	Default: <1> Min.: 30% Max.: 150% <1>	-
L3-14 (04E9)	Stall Prevention Level during Deceleration	StallP Decel Lvl	Used when L3-04 = 1 or 6. 100% is equal to the drive rated current.	Default: <1> Min.: 80% Max.: 200% <1>	-
L3-23 (04FD)	Automatic Reduction Selection for Stall Prevention during Run	CHP Stall P Sel 0: Lvl set in L3-06 1: Autom. Reduction	0: Sets the Stall Prevention level set in L3-04 that is used throughout the entire frequency range. 1: Automatic Stall Prevention level reduction in the constant output range. The lower limit value is 40% of L3-06.	Default: 0 Range: 0, 1	-

B.9 L: Protection Function

No. (Addr. Hex)	Name	LCD Display	Description	Values	Page
L3-27 (0456)	Stall Prevention Detection Time	Stl Prev DetTime	Sets the time the current must exceed the Stall Prevention level to activate Stall Prevention.	Default: 50 ms Min.: 0 Max.: 5000	–
L3-36 (11D0)	Vibration Suppression Gain during Acceleration (with Current Limit)	ILim Acc Gain	Increase the setting value if oscillation occurs in the output current during acceleration.	Default: <3> Min.: 0.0 Max.: 100.0	–
L3-39 (11D3)	Current-limited Integral Time Constant during Acceleration	ILim Acc I Time	Sets the time constant for acceleration rate adjustment for current-limited acceleration.	Default: 100.0 ms Min.: 1.0 Max.: 1000.0	–
L3-40 (11D6)	Current-limited Maximum S-curve Selection during Acceleration	ILimAcc S-Curve 0: Disable 1: Enable	0: Disable 1: Enable	Default: 0 Range: 0, 1	–
L3-41 (11D7)	Vibration Suppression Gain during Deceleration (with Current Limit)	ILim Dec Gain	Increase the setting value if oscillation occurs in the output current during deceleration.	Default: <3> Min.: 1.0 Max.: 100.0	–
L3-44 (11D8)	Current-limited Integral Time Constant during Deceleration	ILim Dec I Time	Sets the time constant for deceleration rate adjustment for current-limited deceleration.	Default: 100.0 ms Min.: 1.0 Max.: 1000.0	–
L3-45 (11D9)	Current-limited Maximum S-curve Selection during Deceleration	ILimDec S-Curve 0: Disable 1: Enable	0: Disable 1: Enable Available when L3-04 = 6.	Default: 0 Range: 0, 1	–

<1> The default setting and upper limit are determined by L8-38, Frequency Reduction Selection.

<3> Default setting is determined by parameter A1-02, Control Method Selection.

◆ L4: Speed Detection

No. (Addr. Hex)	Name	LCD Display	Description	Values	Page
L4-01 (0499)	Speed Agree Detection Level	Spd Agree Level	L4-01 sets the frequency detection level for digital output functions H2-□□ = 2, 3, 4, 5.	Default: 0.0 Hz Min.: 0.0 Max.: 400.0	–
L4-02 (049A)	Speed Agree Detection Width	Spd Agree Width	L4-02 sets the hysteresis or allowable margin for speed detection.	Default: 2.0 Min.: 0.0 Max.: 20.0	–
L4-03 (049B)	Speed Agree Detection Level (+/-)	Spd Agree Lvl+-	L4-03 sets the frequency detection level for digital output functions H2-□□ = 13, 14, 15, 16.	Default: 0.0 Hz Min.: -400.0 Max.: 400.0	–
L4-04 (049C)	Speed Agree Detection Width (+/-)	Spd Agree Wdth+-	L4-04 sets the hysteresis or allowable margin for speed detection.	Default: 2.0 Min.: 0.0 Max.: 20.0	–
L4-05 (049D)	Frequency Reference Loss Detection Selection	Ref Loss Sel 0: Stop 1: Run@L4-06PrevRef	0: Operate following the frequency reference. 1: Run. Drive continues operation according to the setting of L4-06.	Default: 0 Range: 0, 1	–
L4-06 (04C2)	Frequency Reference at Reference Loss	Fref at Floss	Sets the percentage of the frequency reference that the drive should run with when the frequency reference is lost.	Default: 80.0% Min.: 0.0 Max.: 100.0	–
L4-07 (0470)	Speed Agree Detection Selection	Freq Detect Sel 0: No Detection @BB 1: Always Detected	0: No detection during baseblock. 1: Detection always enabled.	Default: 0 Range: 0, 1	–

◆ L5: Fault Restart

No. (Addr. Hex)	Name	LCD Display	Description	Values	Page
L5-01 (049E)	Number of Auto Restart Attempts	Num of Restarts	Sets the number of times the drive may attempt to restart after the following faults occur: GF, LF, oC, oH1, oL1, oL3, oL4, ov, Sto, Uv1.	Default: 5 Min.: 0 Max.: 10	–
L5-02 (049F)	Auto Restart Fault Output Operation Selection	Restart Sel 0: Flt Outp Disabl 1: Flt Outp Enabled	0: Fault output not active. 1: Fault output active during restart attempt.	Default: 0 Range: 0, 1	–
L5-04 (046C)	Fault Reset Interval Time	Flt Reset Wait T	Sets the amount of time to wait between performing fault restarts.	Default: 20.0 s Min.: 10.0 Max.: 3600.0	–
L5-40 (0670)	Low Feedback Fault Retry Selection	Low Feedback 0: No retry 1: Retry	Determines whether the LFB-Low Feedback fault can be auto-restarted. 0: No retry 1: Retry	Default: 0 Range: 0, 1	–
L5-41 (0671)	High Feedback Fault Retry Selection	High Feedback 0: No retry 1: Retry	Determines whether the HFB-High Feedback fault can be auto-restarted. 0: No retry 1: Retry	Default: 0 Range: 0, 1	–
L5-42 (0672)	Feedback Loss Fault Retry Selection	Feedback Loss 0: No retry 1: Retry	Determines whether the FBL-Feedback Loss fault can be auto-restarted. 0: No retry 1: Retry	Default: 0 Range: 0, 1	–
L5-50 (067A)	Setpoint Not Met Retry Selection	SetPoint Not Met 0: No retry 1: Retry	Determines whether the NMS-Setpoint not Met fault can be auto-restarted. 0: No retry 1: Retry	Default: 0 Range: 0, 1	–
L5-51 (067B)	Loss of Prime Fault Retry Selection	Loss of Prime 0: No retry 1: Retry	Determines whether the LOP-Loss of Prime fault can be auto-restarted. 0: No retry 1: Retry	Default: 0 Range: 0, 1	–
L5-52 (067C)	Pump Over Cycle Fault Retry Selection	Pump Over Cycle 0: No retry 1: Retry	Determines whether the POC-Pump Over Cycle fault can be auto-restarted. 0: No retry 1: Retry	Default: 0 Range: 0, 1	–
L5-53 (067D)	Volute-TStat Retry Selection	Volute-TStat Flt 0: No retry 1: Retry	Determines whether the Volute T-Stat fault can be auto-restarted. 0: No retry 1: Retry Note: The drive will restart only after the Volute-Tstat digital input deactivates and the L5-04 timer expires.	Default: 0 Range: 0, 1	–

◆ L6: Torque Detection

No. (Addr. Hex)	Name	LCD Display	Description	Values	Page
L6-01 (04A1)	Torque Detection Selection 1	Torq Det 1 Sel 0: Disabled 1: OL Alm at SpdAgr 2: OL Alm dur RUN 3: OL Flt at SpdAgr 4: OL Flt dur RUN 5: UL Alm at SpdAgr 6: UL Alm dur RUN 7: UL Flt at SpdAgr 8: UL Flt dur RUN 9: UL6Alm at SpdAgr 10: UL6Alm dur RUN 11: UL6Flt at SpdAgr 12: UL6Flt dur RUN	0: Disabled 1: oL3 detection only active during speed agree, operation continues after detection 2: oL3 detection always active during run, operation continues after detection 3: oL3 detection only active during speed agree, output shuts down on an oL3 fault 4: oL3 detection always active during run, output shuts down on an oL3 fault 5: UL3 detection only active during speed agree, operation continues after detection 6: UL3 detection always active during run, operation continues after detection 7: UL3 detection only active during speed agree, output shuts down on an oL3 fault 8: UL3 detection always active during run, output shuts down on an oL3 fault 9: UL6 Alarm at Speed Agree 10: UL6 Alarm during Run 11: UL6 Fault at Speed Agree 12: UL6 Fault during Run	Default: 0 Range: 0 to 12	–
L6-02 (04A2)	Torque Detection Level 1	Torq Det 1 Lvl	Sets the overtorque and undertorque detection level.	Default: 15% Min.: 0 Max.: 300	–
L6-03 (04A3)	Torque Detection Time 1	Torq Det 1 Time	Sets the time an overtorque or undertorque condition must exist to trigger torque detection 1.	Default: 10.0 s Min.: 0.0 Max.: 10.0	–
L6-04 (04A4)	Torque Detection Selection 2	Torq Det 2 Sel 0: Disabled 1: OL Alm at SpdAgr 2: OL Alm dur RUN 3: OL Flt at SpdAgr 4: OL Flt dur RUN 5: UL Alm at SpdAgr 6: UL Alm dur RUN 7: UL Flt at SpdAgr 8: UL Flt dur RUN	0: Disabled 1: oL4 detection only active during speed agree, operation continues after detection 2: oL4 detection always active during run, operation continues after detection 3: oL4 detection only active during speed agree, output shuts down on an oL4 fault 4: oL4 detection always active during run, output shuts down on an oL4 fault 5: UL4 detection only active during speed agree, operation continues after detection 6: UL4 detection always active during run, operation continues after detection 7: UL4 detection only active during speed agree, output shuts down on a UL4 fault 8: UL4 detection always active during run, output shuts down on a UL4 fault	Default: 0 Range: 0 to 8	–
L6-05 (04A5)	Torque Detection Level 2	Torq Det 2 Lvl	Sets the overtorque and undertorque detection level.	Default: 150% Min.: 0 Max.: 300	–
L6-06 (04A6)	Torque Detection Time 2	Torq Det 2 Time	Sets the time an overtorque or undertorque condition must exist to trigger torque detection 2.	Default: 0.1 s Min.: 0.0 Max.: 10.0	–
L6-13 (062E)	Motor Underload Protection Selection	Underload Select 0: Base Freq Enable 1: Max Freq Enable	Sets the motor underload protection (UL6) based on motor load. 0: Base frequency enable 1: Maximum frequency enable	Default: 0 Range: 0, 1	–
L6-14 (062F)	Motor Underload Protection Level at Minimum Frequency	Underload Level	Sets the UL6 detection level at minimum frequency by percentage of drive rated current.	Default: 15% Min.: 0 Max.: 300	–

◆ L7: Torque Limit

No. (Addr. Hex)	Name	LCD Display	Description	Values	Page
L7-01 (04A7)	Forward Torque Limit	Torq Limit Fwd	<p>OLV</p> <p>Sets the torque limit value as a percentage of the motor rated torque. Four individual quadrants can be set.</p>	Default: 200% Min.: 0 Max.: 300	–
L7-02 (04A8)	Reverse Torque Limit	Torq Limit Rev		Default: 200% Min.: 0 Max.: 300	–
L7-03 (04A9)	Forward Regenerative Torque Limit	Torq Lmt Fwd Rgn		Default: 200% Min.: 0 Max.: 300	–
L7-04 (04AA)	Reverse Regenerative Torque Limit	Torq Lmt Rev Rgn		Default: 200% Min.: 0 Max.: 300	–
L7-06 (04AC)	Torque Limit Integral Time Constant	Trq Lim I Time	<p>OLV</p> <p>Sets the integral time constant for the torque limit.</p>	Default: 200 ms Min.: 5 Max.: 10000	–
L7-07 (04C9)	Torque Limit Control Method Selection during Accel/Decel	Trq Lim d AccDec P-ctrl @ Acc/Dec I-ctrl @ Acc/Dec	<p>OLV</p> <p>0: Proportional control (changes to integral control at constant speed). Use this setting when acceleration to the desired speed should take precedence over the torque limit. 1: Integral control. Set L7-07 to 1 if the torque limit should take precedence.</p>	Default: 0 Range: 0, 1	–
L7-16 (0444D)	Torque Limit Process at Start	TLim DlyTime Sel 0: Disabled 1: Enabled	<p>OLV</p> <p>0: Disabled 1: Enabled</p>	Default: 1 Range: 0, 1	–

◆ L8: Drive Protection

No. (Addr. Hex)	Name	LCD Display	Description	Values	Page
L8-02 (04AE)	Overheat Alarm Level	OH Pre-Alarm Lvl	An overheat alarm occurs when heatsink temperature exceeds the L8-02 level.	Default: </> Min.: 50 °C Max.: 150 °C	–
L8-03 (04AF)	Overheat Pre-Alarm Operation Selection	OH Pre-Alarm Sel 0: Ramp to Stop 1: Coast to Stop 2: Fast-Stop 3: Alarm Only 4: Run@L8-19 Rate	0: Ramp to stop. A fault is triggered. 1: Coast to stop. A fault is triggered. 2: Fast Stop. Decelerate to stop using the deceleration time in C1-09. A fault is triggered. 3: Continue operation. An alarm is triggered. 4: Continue operation at reduced speed as set in L8-19.	Default: 3 Range: 0 to 4	–
L8-07 (04B3)	Output Phase Loss Protection Selection	Outp Ph Loss Det 0: Disabled 1: 1PH Loss Det 2: 2/3PH Loss Det	0: Disabled 1: Enabled (triggered by a single phase loss) 2: Enabled (triggered when two phases are lost) Note: Output phase loss detection can mistakenly be triggered if the motor rated current is very small compared to the drive rated output current. Disable this parameter in such cases.	Default: 1 Range: 0 to 2	–
L8-09 (04B5)	Output Ground Fault Detection Selection	Grnd Flt Det Sel 0: Disabled 1: Enabled	0: Disabled 1: Enabled	Default: 1 Range: 0, 1	–
L8-10 (04B6)	Heatsink Cooling Fan Operation Selection	Fan On/Off Sel 0: Dur Run (OffDly) 1: Always On	0: Run with timer (Fan operates only during run and for L8-11 seconds after stop.) 1: Run always (Cooling fan operates whenever the drive is powered up.) Note: If a damping resistor overheat (doH) is detected, the cooling fan will turn on regardless of the setting value.	Default: 0 Range: 0, 1	–
L8-11 (04B7)	Heatsink Cooling Fan Off Delay Time	Fan Delay Time	Sets a delay time to shut off the cooling fan after the Run command is removed when L8-10 = 0.	Default: 300 s Min.: 0 Max.: 300	–

B.9 L: Protection Function

No. (Addr. Hex)	Name	LCD Display	Description	Values	Page
L8-12 (04B8)	Ambient Temperature Setting	Ambient Temp	Enter the ambient temperature. This value adjusts the oL2 detection level.	Default: 40 °C Min.: -10 Max.: 50	–
L8-15 (04BB)	oL2 Characteristics Selection at Low Speeds	OL2 Sel @ L-Spd 0: Disabled 1: Enabled	0: No oL2 level reduction below 6 Hz. 1: oL2 level is reduced linearly below 6 Hz. It is reduced to 70% at 0 Hz. Note: <ol style="list-style-type: none"> Contact Yaskawa before using the drive for applications for which the setting is 0 (disabled). Do not set this parameter to 0 (disabled) in V/f or OLV control. Do not set this parameter to 0 (disabled) in models 4□0302 to 4□0930. 	Default: 1 Range: 0, 1	–
L8-18 (04BE)	Software Current Limit Selection	Soft CLA Sel 0: Disabled 1: Enabled	0: Disabled 1: Enabled	Default: <2> Range: 0, 1	–
L8-19 (04BF)	Frequency Reduction Rate during Overheat Pre-Alarm	Fc Red dur OHAlm	Specifies the frequency reference reduction gain at overheat pre-alarm when L8-03 = 4.	Default: 0.8 Min.: 0.1 Max.: 0.9	–
L8-32 (04E2)	Cooling Fan Failure Selection	MC/FAN PS FltSel 0: Ramp to Stop 1: Coast to Stop 2: Fast-Stop	Determines drive response when a fault occurs with the internal cooling fan. 0: Ramp to stop 1: Coast to stop 2: Fast stop (Decelerate to stop using the deceleration time set to C1-09)	Default: 1 Range: 0 to 2	–
L8-35 (04EC)	Installation Method Selection	Installation Sel 0: IP00/OpenChassis 2: IP20/Nema Type 1 3: Finless/Fin Ext	0: IP00/Open-Chassis enclosure 2: IP20/NEMA 1, UL Type 1 enclosure 3: External heatsink installation	Default: <2> Range: 0 to 3	–
L8-38 (04EF)	Carrier Frequency Reduction	Fc Reduct dur OL 0: Disabled 1: Active below 6Hz 2: Active @ any Spd	0: Disabled 1: Enabled below 6 Hz 2: Enabled for the entire speed range	Default: <2> Range: 0 to 2	–
L8-40 (04F1)	Carrier Frequency Reduction Off Delay Time	Fc Reduct Time	Sets the time that the drive continues running with reduced carrier frequency after the carrier reduction condition is gone. Setting 0.00 s disables the carrier frequency reduction time.	Default: 0.50 s Min.: 0.00 Max.: 2.00	–
L8-41 (04F2)	High Current Alarm Selection	High Cur Alm Sel 0: Disabled 1: Enabled	0: Disabled 1: Enabled. An alarm is triggered at output currents above 150% of drive rated current.	Default: 0 Range: 0, 1	–

<1> Default setting is determined by parameter o2-04, Drive Model Selection.

<2> Default setting is determined by parameters A1-02, Control Method Selection, and o2-04, Drive Model Selection.

<3> Default setting is determined by parameter A1-02, Control Method Selection.

◆ L9: Drive Protection 2

No. (Addr. Hex)	Name	LCD Display	Description	Values	Page
L9-03 (0819)	Carrier Frequency Reduction Level Selection	Fc ReductLvl Sel 0: Disabled 1: Enabled	Selects the level to start the reduction of the frequency or to clear the current frequency level for the automatic reduction of the carrier frequency. There is normally no need to change this parameter from the default value. 0: Reduces the carrier frequency based on the drive rated current that is not derated. 1: Reduces the carrier frequency based on the drive rated current that is derated by the carrier frequency and the temperature selected for C6-02.	Default: 0 Range: 0, 1	–
L9-12 (0B28)	SoH Alarm Selection during bb	SoH ALM Sel 0: Fault 1: Alarm	Sets the SoH (Snubber Discharge Resistor Overheat) alarm to output a fault or a minor fault during baseblock (bb). 0: Outputs a fault for an SoH alarm during baseblock (bb). 1: Outputs a minor fault for an SoH alarm during baseblock (bb).	Default: 0 Range: 0, 1	–

B.10 n: Special Adjustments

The n parameters adjust more advanced performance characteristics such as Hunting Prevention, speed feedback detection, and Online Tuning for motor line-to-line resistance.

◆ n1: Hunting Prevention

No. (Addr. Hex)	Name	LCD Display	Description	Values	Page
n1-01 (0580)	Hunting Prevention Selection	Hunt Prev Select 0: Disabled 1: Enabled	0: Disabled 1: Enabled	Default: 1 Range: 0, 1	–
n1-02 (0581)	Hunting Prevention Gain Setting	Hunt Prev Gain	If the motor vibrates while lightly loaded, increase the gain by 0.1 until vibration ceases. If the motor stalls, decrease the gain by 0.1 until the stalling ceases.	Default: 1.00 Min.: 0.00 Max.: 2.50	–
n1-03 (0582)	Hunting Prevention Time Constant	Hunt Prev Time	Sets the time constant used for Hunting Prevention.	Default: <1> Min.: 0 ms Max.: 500 ms	–
n1-05 (0530)	Hunting Prevention Gain while in Reverse	Hprev Gain @Rev	Sets the gain used for Hunting Prevention. If set to 0, the gain set to n1-02 is used for operation in reverse.	Default: 0.00 Min.: 0.00 Max.: 2.50	–
n1-12 (0B1B)	Vibration Suppression Time Constant	VibSuppress-Time	There is normally no need to change this parameter from the default value.	Default: 0 ms Min.: 0 Max.: 1000	–

<1> Default setting is determined by parameter o2-04, Drive Model Selection.

◆ n2: Speed Feedback Detection Control (AFR) Tuning

No. (Addr. Hex)	Name	LCD Display	Description	Values	Page
n2-01 (0584)	Speed Feedback Detection Control (AFR) Gain	AFR Gain	OLV Sets the internal speed feedback detection control gain in the automatic frequency regulator (AFR). If hunting occurs, increase the set value. If response is low, decrease the set value.	Default: 1.00 Min.: 0.00 Max.: 10.00	–
n2-02 (0585)	Speed Feedback Detection Control (AFR) Time Constant 1	AFR Time	OLV Sets the time constant used for speed feedback detection control (AFR).	Default: 50 ms Min.: 0 Max.: 2000	–

◆ n3: Overexcitation Braking

No. (Addr. Hex)	Name	LCD Display	Description	Values	Page
n3-13 (0531)	Overexcitation Deceleration Gain	Hflux Brake Gain	Sets the gain applied to the V/f pattern during Overexcitation Deceleration (L3-04 = 4).	Default: 1.10 Min.: 1.00 Max.: 2.00	–

◆ n6: Online Tuning

No. (Addr. Hex)	Name	LCD Display	Description	Values	Page
n6-01 (0570)	Online Tuning Selection	Online Tune Sel	OLV 0: Disabled 1: Line-to-line resistance tuning 2: Voltage correction. Setting not possible when Energy Saving is enabled (b8-01).	Default: 0 Range: 0 to 2	–
n6-05 (05C7)	Online Tuning Gain	R1 Comp Gain	OLV Decrease this setting for motors with a relatively large rotor time constant.	Default: 1.0 Min.: 0.1 Max.: 50.0	–

B.11 o: Operator-Related Settings

The o parameters set up the digital operator displays.

◆ o1: HOA Keypad Display Selection

No. (Addr. Hex)	Name	LCD Display	Description	Values	Page
o1-01 (0500) RUN	Drive Mode Unit Monitor Selection	User Monitor Sel	Selects the content of the last monitor that is shown when scrolling through Drive Mode display. Enter the last three digits of the monitor parameter number to be displayed: U□-□□.	Default: 106 (Monitor U1-06) Range: 101 to 914	-
o1-02 (0501) RUN	User Monitor Selection after Power Up	Power-On Monitor 1: Frequency Ref 2: FWD/REV 3: Output Freq 4: Output Current 5: User Monitor	1: Frequency reference (U1-01) 2: Direction 3: Output frequency (U1-02) 4: Output current (U1-03) 5: User-selected monitor (set by o1-01)	Default: 1 Range: 1 to 5	-
o1-03 (0502)	Digital Operator Display Selection	Display Unit Sel 0: 0.01 Hz 1: 0.01% 2: r/min 3: User Units	Sets the units the drive should use to display the frequency reference and motor speed monitors. 0: 0.01 Hz 1: 0.01% (100% = E1-04) 2: r/min (calculated using the number of motor poles setting in E2-04) 3: User-selected units (set by o1-09, o1-10 and o1-11)	Default: 0 Range: 0 to 3	-
o1-05 (0504) RUN	LCD Contrast Control	LCD Contrast	Sets the contrast of the LCD operator.	Default: </> Range: 0, 1	-
o1-06 (0517)	User Monitor Selection Mode	Monitor Mode Sel 0: 3 Mon Sequential 1: 3 Mon Selectable	Selects the monitors displayed on the second and third lines of the digital operator display. 0: 3 Monitor Sequential (displays the next two sequential monitors) 1: 3 Monitor Selectable (set by o1-07 and o1-08)	Default: 1 Range: 0, 1	-
o1-07 (0518)	Second Line Monitor Selection	2nd Monitor Sel	Selects the monitor that is shown in the second line. Enter the last three digits of the monitor parameter number to be displayed: U□-□□. For example, set "403" to display monitor parameter U4-03. Note: Parameter is effective only when o1-06 is set to 1.	Default: 102 Range: 101 to 699	-
o1-08 (0519)	Third Line Monitor Selection	3rd Monitor Sel	Selects the monitor that is shown in the third line. Enter the last three digits of the monitor parameter number to be displayed: U□-□□. For example, set "403" to display monitor parameter U4-03. Note: Parameter is effective only when o1-06 is set to 1.	Default: 191 Range: 101 to 699	-
o1-09 (051C)	Frequency Reference Display Units	Fref Disp Unit 0: "WC:InchOfWater 1: PSI :lb/SqrInch 2: GPM:Gallons/Min 3: °F:DegFahrenheit 4: CFM:Cubic ft/Min 5: CMH:Cubic m/Hr 6: LPH:Litres/Hr 7: LPS:Litres/Sec 8: Bar:Bar 9: Pa:Pascals 10: °C:DegCelsius 11: m: meters 12: ft: feet 13: LPM:Litres/Min 14: CMM:Cubic M/Min 15: "Hg:Inch Mercury 24: Custom Unit 25: No Unit	Sets unit display for the frequency reference parameters and frequency related monitors when o1-03 = 3. 0: WC (Inch of water) 1: PSI (Pounds per square inch) 2: GPM (Gallons per minute) 3: F (Degrees Fahrenheit) 4: CFM (Cubic feet per minute) 5: CMH (Cubic meters per hour) 6: LPH (Liters per hour) 7: LPS (Liters per second) 8: Bar (Bar) 9: Pa (Pascal) 10: C (Degrees Celsius) 11: Mtr (Meters) 12: Ft (Feet) 13: LPM (Liters per minute) 14: CMM (Cubic meters per minute) 15: "Hg (inches of mercury) 24: Custom units (determined by o1-13 to o1-15) 25: None	Default: 25 Range: 0 to 15; 24, 25	-

No. (Addr. Hex)	Name	LCD Display	Description	Values	Page
o1-10 (0520)	User-Set Display Units Maximum Value	UserDisp Scaling	These settings define the display values when o1-03 is set to 3. o1-10 sets the display value that is equal to the maximum output frequency. o1-11 sets the position of the decimal position.	Default: </> Range: 1 to 60000	–
o1-11 (0521)	User-Set Display Units Decimal Display	UserDisp Dec Sel		Default: </> Range: 0 to 3	–
o1-12 (0522) [RUN]	Home Help Text	Top Help on Home 0: Disabled 1: Enabled	Switches the top line of the Home Screen from the Drive Status to defined Help messages. 0: Disabled 1: Enabled	Default: 1 Range: 0, 1	–
o1-13 (3105)	Frequency Reference and Frequency Related Monitor Custom Units 1	Fref Cust Unit 1	Sets the first character of the customer-specified unit display when o1-03 is set to 3 and o1-09 is set to 24.	Default: 41 Range: 20 to 7A	–
o1-14 (3106)	Frequency Reference and Frequency Related Monitor Custom Units 2	Fref Cust Unit 2	Sets the second character of the customer-specified unit display when o1-03 is set to 3 and o1-09 is set to 24.	Default: 41 Range: 20 to 7A	–
o1-15 (3107)	Frequency Reference and Frequency Related Monitor Custom Units 3	Fref Cust Unit 3	Sets the third character of the customer-specified unit display when o1-03 is set to 3 and o1-09 is set to 24.	Default: 41 Range: 20 to 7A	–

<1> Default setting is determined by parameter A1-02, Control Method Selection.

◆ o2: HOA Keypad Keypad Functions

No. (Addr. Hex)	Name	LCD Display	Description	Values	Page
o2-02 (0506)	STOP Key Function Selection	Oper STOP Key 0: Disabled 1: Enabled	0: Disabled. STOP key is disabled in REMOTE operation. 1: Enabled. STOP key is always enabled.	Default: 1 Range: 0, 1	–
o2-03 (0507)	User Parameter Default Value	User Default Sel 0: No Change 1: Save User Init 2: Clear User Init	0: No change. 1: Set defaults. Saves parameter settings as default values for a User Initialization. 2: Clear all. Clears the default settings that have been saved for a User Initialization.	Default: 0 Range: 0 to 2	–
o2-04 (508)	Drive Model Selection	Inverter Model #	Enter the drive model. Setting required only if installing a new control board.	Default: Determined by drive capacity	–
o2-05 (0509)	Frequency Reference Setting Method Selection	Oper Ref Method 0: Disabled 1: Enabled	0: ENTER key must be pressed to enter a frequency reference. 1: ENTER key is not required. The frequency reference can be adjusted using the up and down arrow keys only.	Default: 0 Range: 0, 1	–
o2-06 (050A)	Operation Selection when Digital Operator is Disconnected	Oper Discon Det 0: Disabled 1: Enabled	0: The drive continues operating if the digital operator is disconnected. 1: An oPr fault is triggered and the motor coasts to stop.	Default: 1 Range: 0, 1	–
o2-07 (0527)	Motor Direction at Power Up when Using Operator	For/RevSel@PwrUp 0: Forward 1: Reverse	This parameter requires assigning drive operation to the digital operator. 0: Forward 1: Reverse	Default: 0 Range: 0, 1	–
o2-09 (050D)	–	–	Factory use.	–	–
o2-19 (061F)	Parameter Set Selection Write during Uv	ParameterSet Sel 0: Disabled 1: Enabled	Selects whether parameter settings can be changed during a control circuit undervoltage condition. To be used with 24 V Power Supply Unit Built-in model. 0: Disabled 1: Enabled	Default: 0 Range: 0, 1	–
o2-30 (1230) [RUN]	Monitor Position Save	Mon Pos Save	Saves the monitor position and Home Screen quick monitor selection. When disabled, entering the Monitor Menu jumps the selection to the Monitor number instead of the group number. 0: Disabled 1: Enabled	Default: 0 Range: 0, 1	–

B.11 o: Operator-Related Settings

◆ o3: Copy Function

No. (Addr. Hex)	Name	LCD Display	Description	Values	Page
o3-01 (0515)	Copy Function Selection	COPY SELECT 0: COPY SELECT 1: INV→OP READ 2: OP→INV WRITE 3: OP←→INV VERIFY	0: Copy select 1: INV → OP READ (Read parameters from the drive, saving them onto the digital operator). 2: OP → INV WRITE (Copy parameters from the digital operator, writing them to the drive). 3: OP → INV VERIFY (Verify that parameter settings match the data saved on the operator). To read the drive parameter settings into the digital operator, set o3-02 to 1 (to allow reading).	Default: 0 Range: 0 to 3	–
o3-02 (0516)	Copy Allowed Selection	Read Allowable 0: Disabled 1: Enabled	Selects whether the read operation (o3-01 = 1) is enabled or disabled. 0: Read operation prohibited 1: Read operation allowed	Default: 1 Range: 0, 1	–

◆ o4: Maintenance Monitor Settings

No. (Addr. Hex)	Name	LCD Display	Description	Values	Page
o4-01 (050B)	Cumulative Operation Time Setting	DrvElapsTimeCnt	Sets the value for the cumulative operation time of the drive in units of 10 h.	Default: 0 Min.: 0 Max.: 9999	–
o4-02 (050C)	Cumulative Operation Time Selection	ElapsTimeCntSet 0: Power-On Time 1: Running Time	0: Logs power-on time 1: Logs operation time when the drive output is active (output operation time).	Default: 0 Range: 0, 1	–
o4-03 (050E)	Cooling Fan Operation Time Setting	FanElapsTimeCn	Sets the value of the fan operation time monitor U4-03 in units of 10 h.	Default: 0 Min.: 0 Max.: 9999	–
o4-05 (051D)	Capacitor Maintenance Setting	BusCap Maint Set	Sets the value of the Maintenance Monitor for the capacitors. See U4-05 to check when the capacitors may need to be replaced.	Default: 0% Min.: 0 Max.: 150	–
o4-07 (0523)	DC Bus Pre-Charge Relay Maintenance Setting	ChrgCircMaintSet	Sets the value of the Maintenance Monitor for the soft charge bypass relay. See U4-06 to check when the bypass relay may need to be replaced.	Default: 0% Min.: 0 Max.: 150	–
o4-11 (0510)	U2, U3 Initialization	Fault Data Init 0: Disabled 1: Enabled	0: U2-□□ and U3-□□ monitor data is not reset when the drive is initialized using A1-03. 1: U2-□□ and U3-□□ monitor data is reset when the drive is initialized using A1-03. Parameter is automatically reset to 0.	Default: 0 Range: 0, 1	–
o4-12 (0512)	kWh Monitor Initialization	kWh Monitor Init 0: No Reset 1: Reset	0: No action 1: Reset kWh data	Default: 0 Range: 0, 1	–
o4-13 (0528)	Number of Run Commands Counter Initialization	Run Counter Init 0: No Reset 1: Reset	0: U4-02 monitor data is not reset when the drive is initialized using A1-03. 1: U4-02 monitor data is reset when the drive is initialized using A1-03. Parameter is automatically reset to 0.	Default: 0 Range: 0, 1	–
o4-17 (3100)	Set/Reset Real-Time Clock	Date/Time Config 0: — — 1: Set 2: Reset	Sets the current date and time for the Real-Time Clock. 0: -- 1: Set 2: Reset	Default: 0 Range: 0 to 2	116
o4-19 (113A)	Power Unit Price	Energy Price/kWh	Sets the price per 1 kWh to calculate the power rate displayed for total consumed power (U9-07 to U9-10) and total regenerated power (U9-11 to U9-14).	Default: 000.00 Min.: 000.00 Max.: 650.00	–
o4-20 (081F)	Time Display Format	Time Disp Format 0: 12-hour (AM/PM) 1: 24-hour	Sets the time display format. 0: 12-hour (AM/PM) 1: 24-hour	Default: 0 Range: 0, 1	–

B.12 P: Pump Parameters

◆ P1: Pump Basic

No. (Addr. Hex)	Name	LCD Display	Description	Values	Page
P1-01 (0C00)	Pump Mode	Pump Mode 0: Drive Only 1: Contactor Lag	0: Drive only 1: Contactor lag	Default: 0 Range: 0, 1	183
P1-02 (0C01)	System Units	System Units 0: No Unit 1: PSI :lb/SqrInch 2: Pa:Pascals 3: Bar:Bar 4: "WC:InchOfWater 5: "Hg:Inch Mercury 6: ft: feet 7: m: meters 8: °F:DegFahrenheit 9: °C:DegCelsius 10: %: Percent 11: kPA: kilopascal 25: Flow (use P6-04) 26: Custom(P1-32~34)	0: No unit 1: PSI: Pounds per square inch 2: Pa: Pascals 3: Bar: Bar 4: "WC: Inch of water 5: "Hg: Inch of Mercury 6: ft: feet 7: m: meters 8: °F: Degrees Fahrenheit 9: °C: Degrees Celsius 10: Percent 11: kPA: kilopascal 25: Flow (Use P6-04) <-> 26: Custom units	Default: 1 Range: 0 to 11; 25, 26	183
P1-03 (0C02)	Feedback Device Scaling	FB Dev. Scaling	Sets the scaling of feedback device in user-set units.	Default: 145.0 PSI <-> Min.: 0.1 Max.: 6000.0	184
P1-04 (0C03) [RUN]	Start / Draw Down Level	Start-DrawDn Lvl	The system starts when the feedback level drops below the start level for the time set in P1-05. This level also specifies the wake-up level when the drive is in Sleep Mode. When this parameter is set to a negative value, the feedback level must drop that amount below the setpoint. Setting this parameter to 0.0 disables the function. Note: When PID operates in reverse mode, the system will start when the feedback has risen above the start level for the time set to P1-05.	Default: 0.0 PSI <-> Min.: 0.0 Max.: 999.9	184
P1-05 (0C02) [RUN]	Start Level Delay Time	S-Lev Delay Time	The system starts when the feedback level drops below the start level for the time set in this parameter.	Default: 1 s Min.: 0 Max.: 3600	184
P1-06 (0C05) [RUN]	Minimum Pump Speed	Min. Pump Speed	Minimum frequency at which the drive will run. Applies to both HAND and Automatic modes. Note: For minimum pump frequency, the drive will use the highest setting from among P1-06, P4-12 (Thrust Bearing Frequency), or d2-02 (Reference Lower Limit).	Default: 40.0 Hz <-> Min.: 0.0 Max.: [E1-04]	184
P1-07 (0C06) <->	Minimum Pump Speed Units	MinPumpSpdUnits 0: Hz 1: RPM	Sets the units and decimal place for parameter P1-06. 0: Hz 1: RPM Note: Changing this parameter will reset the P1-06 default value.	Default: 0 Range: 0, 1	-
P1-08 (0C07) [RUN]	Low Feedback Level	Low FB Level	Sets the lower detection level for the PID feedback.	Default: 0.0 PSI <-> Min.: 0.0 Max.: 999.9 <->	185
P1-09 (0C08) [RUN]	Low Feedback Level Fault Delay Time	Low Lvl FLT Time	Sets the amount of delay time from when the low feedback is detected until the drive faults on an "LFB Low Feedback" fault. Note: This parameter is effective only when P1-10 is set to 0 (Fault).	Default: 10 s Min.: 0 Max.: 3600	185
P1-10 (0C09)	Low Feedback Selection	Low FB Sel 0: Fault 1: Alarm 2: Digital Output	Selects drive response during the "Low Feedback" condition. 0: Fault 1: Alarm 2: Digital out only	Default: 0 Range: 0 to 2	185

B.12 P: Pump Parameters

No. (Addr. Hex)	Name	LCD Display	Description	Values	Page
P1-11 (0C0A) <input type="button" value="RUN"/>	High Feedback Level	High FB Level	Sets the upper detection level for the PID feedback.	Default: 155.0 PSI <-> Min.: 0.0 Max.: 999.9	186
P1-12 (0C0B) <input type="button" value="RUN"/>	High Feedback Level Fault Delay Time	High Lvl FLT Time	Sets the amount of delay time from when the high feedback is detected until the drive faults on a “HFB High Feedback” fault. Note: This parameter is effective only when P1-13 is set to 0 (Fault (and digital out)).	Default: 5 s Min.: 0 Max.: 3600	186
P1-13 (0C0C)	High Feedback Selection	High FB Sel 0: Fault 1: Alarm 2: Digital Output	Selects drive response during the “High Feedback” condition. 0: Fault 1: Alarm 2: Digital out only	Default: 0 Range: 0 to 2	186
P1-14 (0C0D) <input type="button" value="RUN"/>	Hysteresis Level	Hysteresis Level	Sets the hysteresis level used for low and high level feedback detection.	Default: 0.0 PSI <-> Min.: 0.0 Max.: 100.0	–
P1-15 (0C0E) <input type="button" value="RUN"/>	Maximum Setpoint Difference	Max Set Pnt Diff	Sets the level that the difference between the setpoint and the feedback must exceed for the time set in P1-16 to trigger the drive response set in P1-17. If P1-17 is set to 1 (Fault and digital out), the will coast to stop. This function is active when the drive is running during AUTO Mode. Setting this parameter to 0.0 disables the function.	Default: 0.0 PSI <-> Min.: 0.0 Max.: 6000.0	–
P1-16 (0C0F) <input type="button" value="RUN"/>	Not Maintaining Setpoint Time	Not Maint SP Tm	Sets the delay time before a “Setpoint Not Met” condition occurs. The pump protection criteria set in P1-15 must be met before the timer will start. Setting P1-15 to 0.0 disables this function.	Default: 60 s Min.: 0 Max.: 3600	–
P1-17 (0C10)	Not Maintaining Setpoint Selection	Not Maint SP Sel 0: Fault 1: Alarm 2: Digital Output	Selects the drive response method during the “Not Maintaining Setpoint” condition. 0: Fault 1: Alarm 2: Digital out only	Default: 0 Range: 0 to 2	–
P1-18 (0C11)	Prime Loss Detection Method	Prime Loss Mthd 0: Current (A) 1: Power (kW) 2: Torque (%)	Determines the quantity used to determine loss of prime. 0: Current (A) 1: Power (kW) 2: Torque (%)	Default: 0 Range: 0 to 2	–
P1-19 (0C12) <input type="button" value="RUN"/>	Prime Loss Level	Prime Loss Level	Detects loss of prime in the pump when in Auto or Sleep Boost Mode. When the measured quantity determined by P1-18 drops below this level for the time set in P1-20 and the output frequency is above the level set in P1-21, a “Loss of Prime” condition occurs. The drive responds to the “Loss of Prime” condition depending on the setting of P1-22, Loss of Prime Selection.	Default: 0.0 A <-> Min.: 0.0 Max.: 1000.0	–
P1-20 (0C13) <input type="button" value="RUN"/>	Loss of Prime Time	Prime Loss Time	Sets the delay time before a “Loss of Prime” condition occurs. The pump protection criteria set in P1-18 and P1-19 must be met before the timer will start.	Default: 20 s Min.: 0 Max.: 600	–
P1-21 (0C14)	Loss of Prime Frequency	Prime Loss Freq	Sets the frequency level above which the “Loss of Prime” detection is enabled when set to a value other than 0. When set to 0 (default), the frequency level is determined by the smaller value between (Fmax - 1 Hz) and (d2-01 - 1 Hz).	Default: 0.0 Hz Min.: 0.0 Max.: [E1-04]	–
P1-22 (0C15)	Loss of Prime Selection	Prime Loss Sel 0: Fault 1: Alarm 2: Digital Output	Sets the drive response method during the “Loss of Prime” condition. 0: Fault 1: Alarm 2: Digital out only	Default: 0 Range: 0 to 2	–
P1-23 (0C16)	Loss of Prime Maximum Restart Time after Fault	LOP Max Rstrt T	Sets the time in minutes that the drive will wait before attempting another restart when the restart fails or is not attempted due to a continuing fault condition.	Default: 0.2 min Min.: 0.2 Max.: 6000.0	–
P1-24 (0C17)	Level at Full Speed	Level @ Full Spd	When set greater than 0, this level is used to override the P-gain and I-limit with a calculated value based on Sleep level, Wake-up level, Minimum Pump Speed, Transducer Scaling, and Maximum Frequency. This feature is disabled when set to 0.	Default: 0.0 Min.: 0.0 Max.: 6000.0	–

No. (Addr. Hex)	Name	LCD Display	Description	Values	Page
P1-30 (0C1D)	Low Water Digital Input Configuration	Low Water DI Sel 0: Normally Open 1: Normally Closed	Selects the configuration of the low water level digital input. 0: Normally open 1: Normally closed	Default: 0 Range: 0, 1	–
P1-31 (0C1E)	High Water Digital Input Configuration	HighWater DI Sel 0: Normally Open 1: Normally Closed	Selects the configuration of the high water level digital input. 0: Normally open 1: Normally closed	Default: 0 Range: 0, 1	–
P1-32 (0C1F)	System Units Custom 1st Character	Sys Unit Custom1	Sets the first character of the custom unit display when P1-02 = 26.	Default: 41 Min.: 20 Max.: 7A	–
P1-33 (0C20)	System Units Custom 2nd Character	Sys Unit Custom2	Sets the second character of the custom unit display when P1-02 = 26.	Default: 41 Min.: 20 Max.: 7A	–
P1-34 (0C21)	System Units Custom 3rd Character	Sys Unit Custom3	Sets the third character of the custom unit display when P1-02 = 26.	Default: 41 Min.: 20 Max.: 7A	–
P1-40 (0C27) <u>RUN</u>	Maximum Pump Speed	Max Pump Speed	Sets the maximum pump speed. This parameter does not affect operation when set to 0.0 or when set to a value higher than E1-04 x d2-01. This parameter is internally lower limited to the minimum pump speed (P1-06, P4-12, d2-02) when not set to 0.0.	Default: 0.0 Hz Min.: 0.0 Max.: 440.0	186

- <2> System units are set by P6-04, Water Flow Units. The PID Feedback is rerouted to come from the flow meter, pulse input (H6-01 = 5), or analog (H3-0□ = 22).
- <3> Unit text is set by P1-02, System Units.
- <4> Unit range and resolution are determined by P1-07, Minimum Pump Speed Units. Setting P1-07 to 1 (RPM) will set a default value of 900 RPM (VTC) and 2400 RPM (all others). Setting P1-07 to 0 (Hz, default) will set a default value of 40.0 Hz.
- <5> Unit text is set by P1-18, Prime Loss Detection Method.
- <8> Range is 0.0~999.9 with sign-bit “-” indicating Delta to Setpoint

◆ P2: Pump Protection

No. (Addr. Hex)	Name	LCD Display	Description	Values	Page
P2-01 (0C64)	Sleep Level Type	Sleep Lvl Type 0: Output Frequency 1: Output Current 2: Feedback 3: Output Speed-RPM 4: Flow Meter	0: Output frequency 1: Output current 2: Feedback 3: Output speed (RPM) 4: Flow meter (requires flow meter) Note: Feedback depends on PID direction operation.	Default: 0 Range: 0 to 4	187
P2-02 (0C65) <u>RUN</u>	Sleep Level	Sleep Level	Sleep activates when the selected level type (P2-01 setting) reaches the programmed sleep level for the time set in P2-03. This function is active when the drive is running during AUTO Mode. Setting this parameter below minimum pump speed (P1-06) disables Sleep Level (P2-02) and sleep activates at minimum pump speed.	Default: 0.0 Hz <> Min.: 0.0 Max.: 6000.0	187
P2-03 (0C66) <u>RUN</u>	Sleep Delay Time	Sleep Delay Time	Sets the delay time before the drive enters Sleep Mode when the sleep level set in P2-02 is reached.	Default: 5 s Min.: 0 Max.: 3600	187
P2-04 (0C67) <u>RUN</u>	Sleep Activate Level	Sleep Act. Level	Sets the level above which the output frequency must rise to activate the sleep function when P2-01, Sleep Level Type, is set to 0 (Output Frequency / Speed). Setting this parameter to 0.0 disables the function and the sleep function will activate when P2-02, Sleep Level, is reached.	Default: 0.0 Hz <> Min.: 0.0 Max.: 6000.0	–
P2-05 (0C68) <u>RUN</u>	Sleep Boost Level	Sleep Boost Lvl	Sets the amount of boost applied to the setpoint before going to sleep. Setting this parameter to 0.0 disables the function.	Default: 0.0 PSI <> Min.: 0.0 Max.: 6000.0	–
P2-06 (0C69) <u>RUN</u>	Sleep Boost Hold Time	SleepBoost HldTm	Sets the amount of time that the boosted pressure will be maintained before the drive goes to sleep.	Default: 5.0 s Min.: 0.5 Max.: 160.0	–

B.12 P: Pump Parameters

No. (Addr. Hex)	Name	LCD Display	Description	Values	Page
P2-07 (0C6A) <input type="button" value="RUN"/>	Sleep Boost Maximum Time	SleepBoost MaxTm	Sets the amount of time that the system (feedback) has to reach the boosted setpoint. The drive will go to sleep when the amount of time set in this parameter has been exceeded.	Default: 20.0 s Min.: 1.0 Max.: 160.0	–
P2-08 (0C6B) <input type="button" value="RUN"/>	Delta Sleep Feedback Drop Level	D Fb Drop Level	If the PID Error (setpoint minus feedback) exceeds the level programmed in this parameter within the time window set in P2-09 and the output frequency is greater than the level set in P1-06, the sleep operation deactivates and the drive returns to normal operation. Setting this parameter to 0.0 disables the function.	Default: 0.0 PSI <3> Min.: 0.0 Max.: 6000.0	–
P2-09 (0C6C) <input type="button" value="RUN"/>	Feedback Detection Drop Time	FB Drop Det. Time	Defines the time window in which the software monitors the feedback to detect a flow/no-flow condition.	Default: 10.0 s Min.: 0.0 Max.: 3600.0	–
P2-10 (0C6D) <input type="button" value="RUN"/>	Sleep Mode: Cycling Protection	Cycle Protection	Sets the maximum number of cycles that are allowed within the time specified in P2-11 before tripping the PoC “Pump Over Cycle” fault. One cycle is defined when the drive transfers from normal operation in AUTO Mode to Sleep Mode. Setting this parameter to 0 disables the function.	Default: 0 Min.: 0 Max.: 10	–
P2-11 (0C6E) <input type="button" value="RUN"/>	Sleep Mode: Maximum Cycling Protection Time	Max. Cycle Time	Sets the maximum time allowed between cycles. When no cycling occurs within the programmed time, the drive will decrease the internal cycle register.	Default: 300 s Min.: 0 Max.: 3600	–
P2-12 (0C6F)	Over Cycling Mode	Over Cycle Mode 0: Disabled 1: Alarm Only 2: Fault 3: Auto SP Comp.	0: Disabled 1: Alarm 2: Fault 3: Auto SP Compensation	Default: 0 Range: 0 to 3	–
P2-13 (0C70)	Setpoint Compensation	Setpoint Comp.	Allows for the software to automatically compensate the setpoint in the event of excessive cycling.	Default: 0.0 PSI <3> Min.: 0.0 Max.: 6000.0	–
P2-14 (0C71)	Maximum Setpoint Compensation	Max. SP Comp.	Sets the maximum allowed setpoint compensation for over-cycling function.	Default: 0.0 PSI <3> Min.: 0.0 Max.: 6000.0	–
P2-15 (0C72) <input type="button" value="RUN"/>	Sleep AUTO -> Off Selection	Sleep AUTO->Off 0: Disabled 1: Enabled	Enabling this parameter activates Sleep if the P1-04 Start Level is set to 0 and switches the drive to OFF mode when called to Sleep. 0: Disabled 1: Enabled	Default: 0 Range: 0, 1	187
P2-23 (0C7A) <input type="button" value="RUN"/>	Anti-No-Flow Bandwidth	ANF Bandwidth	Sets the amount of PI error bandwidth used to detect the Anti-No-Flow condition. Avoid setting this parameter value too high, as operation may become unstable. Setting this parameter to 0.00 will disable the function.	Default: 0.40% Min.: 0.00 Max.: 2.00	–
P2-24 (0C7B) <input type="button" value="RUN"/>	Anti-No-Flow Detection Time	ANF Det. Time	Sets the time delay before the drive starts the increased deceleration rate after Anti-No-Flow is detected.	Default: 10.0 s Min.: 1.0 Max.: 60.0	–
P2-25 (0C7C) <input type="button" value="RUN"/>	Anti-No-Flow Release Level	ANF Release Lvl	Sets the amount below the setpoint which the feedback must drop to disengage the Anti-No-Flow and return to normal PI operation.	Default: 3.0 PSI <3> Min.: 0.0 Max.: 100.0	–

<1> Display units vary depending on the setting for P2-01, Sleep Level Type. When P2-01 is set to 0, the display units are “Hz”; setting 1 is “A”; setting 2 is P1-02 Selection; setting 3 is “RPM”; setting 4 is P6-04 selection.

<2> Display units vary depending on the setting for P2-01, Sleep Level Type. When P2-01 is set to 0, 1, 2, or 4, the display units are “Hz”; setting 3 is “RPM”.

<3> Unit is determined by P1-02, System Units, setting.

◆ P3: Contactor Multiplexing

No. (Addr. Hex)	Name	LCD Display	Description	Values	Page
P3-00 (0CC7)	Number of Lag Pumps	Num of Lag Pumps	Sets the number of lag pumps present.	Default: 1 Min.: 1 Max.: 5	187
P3-01 (0CC8)	Add Pump Control	Add Pump Control 0: Output Frequency 1: Feedback 2: Feedback + Fout	Selects the method for adding contactor pumps to the system. 0: Output frequency (Uses P3-03 and P3-05) 1: Feedback (Uses P3-04 and P3-05) 2: Feedback + Fout (Uses P3-03, P3-04, and P3-05)	Default: 0 Range: 0 to 2	–
P3-02 (0CC9)	Shutdown Pump Control	Shutdown Pump Ctl 0: Output Frequency 1: Feedback 2: Feedback + Fout	Selects the method for removing contactor pumps from the system. 0: Output frequency (Uses P3-09, P3-50 P3-60, P3-70, P3-80, and P3-90) 1: Feedback (Uses P3-08 and P3-09) 2: Feedback + Fout (Uses P3-08, P3-09, P3-50, P3-60, P3-70, P3-80, and P3-90)	Default: 0 Range: 0 to 2	–
P3-03 (0CCA) <input type="checkbox"/> RUN	Drive Multi/Maximum Level	Max-Multi Level	Sets the maximum level used for the multiplex pumping operation. Parameter is active only when P3-01 is set to 0 or 2. When P3-01 is set to 0, the next available pump will be added to the system by a multi-function Discrete Output closure (H2-0□ = 80 to 84) when the output frequency rises above the level set in this parameter for the time set in P3-05. When P3-01 is set to 2, the next available pump will be added to the system by a multi-function Discrete Output closure (H2-0□ = 80 to 84) when the output frequency rises above the level set in this parameter and the delta feedback (setpoint minus feedback) has exceeded the level programmed in P3-04 for the time set in P3-05.	Default: 59.0 Hz Min.: 0.0 Max.: 400.0	–
P3-04 (0CCB) <input type="checkbox"/> RUN	Add Pump Delta Level	Add Pump D-Lvl	Sets the level used for the multiplex pumping operation. Parameter is active only when P3-01 is set to 1 or 2. When P3-01 is set to 1, the next available pump will be added to the system by a multi-function Discrete Output closure (H2-0□ = 80 to 84) when the delta feedback (setpoint minus feedback) has exceeded the level set in this parameter for the time set in P3-05. When P3-01 is set to 2, the next available pump will be added to the system by a multi-function Discrete Output closure (H2-0□ = 80 to 84) when the output frequency rises above the level set in P3-03 and the delta feedback (setpoint minus feedback) has exceeded the level set in this parameter for the time set in P3-05. Note: Programming this parameter too close to the system setpoint may cause the pump system to cycle excessively.	Default: 0.0 PSI </> Min.: 0.0 Max.: 6000.0	–
P3-05 (0CCC) <input type="checkbox"/> RUN	Add Pump Delay Time	Add Pump Dly Tm	Sets the delay time before a pump is added to the system.	Default: 2 s Min.: 0 Max.: 3600	–
P3-06 (0CCD) <input type="checkbox"/> RUN	Frequency Reduction after Staging	FreqReduce@Stage	Sets the upper limit of the output frequency after a lag pump is staged. The upper limit of the output frequency is calculated by subtracting the value of this parameter from parameter P3-03. Output limit = P3-03 - P3-06	Default: 0.0 Hz Min.: 0.0 Max.: 30.0	–
P3-07 (0CCE) <input type="checkbox"/> RUN	Frequency Reduction after Staging Time	FreqReduce Time	Sets the amount of time that the output frequency will be limited after lag pump is staged.	Default: 0.0 s Min.: 0.0 Max.: 240.0	–

B.12 P: Pump Parameters

No. (Addr. Hex)	Name	LCD Display	Description	Values	Page
P3-08 (0CCF) <input type="checkbox"/> RUN	Shutdown Pump Delta Level	Shdn Pump D-Lvl	<p>Sets the level used for the multiplex pumping operation. Parameter is active only when P3-02 is set to 1 or 2. When P3-02 is set to 1, the last pump that was brought online will be shut down by opening the dedicated multi-function discrete output (H2-0□ = 80 to 84) when the delta feedback (feedback minus setpoint) has exceeded the level programmed in this parameter for the time set in P3-09.</p> <p>When the P3-02 is set to 2, the last pump that was brought online will be shut down by opening the dedicated multi-function discrete output (H2-0□ = 80 to 84) when the output frequency drops below the level programmed in P3-50, P3-60, P3-70, P3-80, or P3-90 and the delta feedback (feedback minus setpoint) has exceeded the level set in this parameter for the time set in P3-09.</p> <p>Note: Programming this parameter too close to the system setpoint may cause the pump system to cycle excessively.</p>	Default: 0.0 PSI </> Min.: 0.0 Max.: 6000.0	–
P3-09 (0CD0) <input type="checkbox"/> RUN	Shutdown Pump Delay Time	Shdn Pump Dly Tm	Sets the delay time before one of the additional line pumps is shut down.	Default: 5 s Min.: 0 Max.: 3600	–
P3-10 (0CD1) <input type="checkbox"/> RUN	Setpoint Boost Maximum at De-Stage	MaxBoost@DeStage	<p>Sets the maximum amount of boost that can be added to the setpoint after a de-stage occurs.</p> <p>Setting this parameter to 0.0 disables the function.</p>	Default: 0.0 PSI </> Min.: -20.0 Max.: 20.0	–
P3-11 (0CD2) <input type="checkbox"/> RUN	Setpoint Boost after De-Stage Time	SP Boost Time	Sets the amount of time that the setpoint will remain boosted after lag pump is de-staged.	Default: 5.0 s Min.: 0.0 Max.: 60.0	–
P3-12 (0CD3) <input type="checkbox"/> RUN	Multi Pump Setpoint Increase during Transition	MP Setpoint Inc	<p>Sets the system setpoint increase each time a new pump is brought online.</p> <p>Pump 1: Setpoint Pump 1 + 2: Setpoint + P3-12 Pump 1 + 2 + 3: Setpoint + 2 x P3-12</p>	Default: 0.0 PSI </> Min.: 0.0 Max.: 6000.0	–
P3-13 (0CD4) <input type="checkbox"/> RUN	Multi Pump Setpoint Decrease during Transition	MP Setpoint Dec	<p>Sets the system setpoint decrease each time a new pump is brought online.</p> <p>Pump 1: Setpoint Pump 1 + 2: Setpoint - P3-13 Pump 1 + 2 + 3: Setpoint - 2 x P3-13</p>	Default: 0.0 PSI </> Min.: 0.0 Max.: 6000.0	–
P3-14 (0CD5) <input type="checkbox"/> RUN	Multiplex Stabilization Time	M-Stabilize Time	<p>Sets the time used to stabilize the system when a pump is added or shut down during multiplex operation.</p> <p>When a pump is added, the stabilize timer temporarily disables the lead/lag functionality for the programmed time to prevent pump cycling.</p> <p>Function is active in contactor multiplex mode (P1-01 = 1). Time pump protection and lead/lag control is suspended during stabilization time.</p>	Default: 2 s Min.: 0 Max.: 3600	–
P3-15 (0CD6) <input type="checkbox"/> RUN	High Feedback Quick De-stage	High FB De-stage	<p>Sets the High Feedback level that will trigger a quick de-stage. The quick de-stage uses an internal 2 sec delay.</p> <p>A setting of 0 disables this feature.</p>	Default: 0.0 PSI </> Min.: 0.0 Max.: 6000.0	–
P3-16 (0CD7) <input type="checkbox"/> RUN	Low Feedback Quick De-stage	Low FB De-stage	<p>Sets the Low Feedback level that will trigger a quick de-stage. The quick de-stage uses an internal 2 sec delay.</p> <p>A setting of 0 disables this feature.</p>	Default: 0.0 PSI </> Min.: 0.0 Max.: 6000.0	–
P3-30 (0CE5)	Stage Selection Mode	Stage Sel Mode 0: Sequential 1: Stop History	<p>Sets the method of staging for the pumps.</p> <p>0: Sequential 1: Stop history</p>	Default: 0 Range: 0, 1	–
P3-31 (0CE6)	De-Stage Selection Mode	Destage Sel Mode 0: LastInFirstOut 1: FirstInFirstOut	<p>Sets the method for removing contactor pumps.</p> <p>0: Last in, first out (LIFO) 1: First in, first out (FIFO)</p>	Default: 0 Range: 0, 1	–

No. (Addr. Hex)	Name	LCD Display	Description	Values	Page
P3-40 (0CEF)	Pre-Charge Lag Pump Select	Precharge LagSel 0: Disabled 2: Pump2 (H2-0X=80) 3: Pump3 (H2-0X=81) 4: Pump4 (H2-0X=82) 5: Pump5 (H2-0X=83) 6: Pump6 (H2-0X=84)	Selects which of the lag pumps can come on during a pre-charge. 0: Disabled 2: Pump 2 (H2-0□ = 80) 3: Pump 3 (H2-0□ = 81) 4: Pump 4 (H2-0□ = 82) 5: Pump 5 (H2-0□ = 83) 6: Pump 6 (H2-0□ = 84)	Default: 0 Range: 0; 2 to 6	–
P3-41 (0CF0)	Pre-Charge Lag Pump Run Time	Precharge Lag Tm	Sets the length of time that the lag pump specified in P3-40 is energized.	Default: 0.0 min Min.: 0.0 Max.: 3600.0	–
P3-42 (0CF1)	Post-Pre-Charge Lag Pump Operation	Post PreChg Lag 0: Turn Off 1: Continue	Determines whether the lag pump set in pre-charge (P3-40) turns off or maintains its state when pre-charge is completed. 0: Turn off 1: Continue	Default: 0 Range: 0, 1	–
P3-43 (0CF2)	Pre-Charge Lag Pump Delay Time	PreChg Lag Delay	Sets the length of time that the drive is in the pre-charge mode before the lag pump set in P3-40 is energized.	Default: 2.0 min Min.: 0.0 Max.: 600.0	–
P3-50 (0CF9) <u>RUN</u>	Pump 2 Frequency Shutdown Level	P2 Shutdown Freq	Sets the level used for the multiplex pumping operation. Parameter is active only when P3-02 is set to 0 or 2. When P3-02 is set to 0 and a total of two pumps are running, the last pump (Pump 2) that was brought online will be shut down by opening the dedicated multi-function discrete output (H2-0□ = 80 to 84) when the output frequency falls below the level set in this parameter for the time set in P3-09. When P3-02 is set to 2 and a total of two pumps are running, the last pump (Pump 2) that was brought online will be shut down by opening the dedicated multi-function discrete output (H2-0□ = 80 to 84) when the delta feedback (setpoint minus feedback) has exceeded the level programmed in this parameter for the time set in P3-09.	Default: 40.0 Hz Min.: 0.0 Max.: 400.0	188
P3-60 (11E5) <u>RUN</u>	Pump 3 Frequency Shutdown Level	P3 Shutdown Freq	Sets the level used for the multiplex pumping operation. Parameter is active only when P3-02 is set to 0 or 2. Parameter function is similar to P3-50, except for Pump 3 instead of Pump 2.	Default: 40.0 Hz Min.: 0.0 Max.: 400.0	188
P3-70 (11EF) <u>RUN</u>	Pump 4 Frequency Shutdown Level	P4 Shutdown Freq	Sets the level used for the multiplex pumping operation. Parameter is active only when P3-02 is set to 0 or 2. Parameter function is similar to P3-50, except for Pump 4 instead of Pump 2.	Default: 40.0 Hz Min.: 0.0 Max.: 400.0	188
P3-80 (11F9) <u>RUN</u>	Pump 5 Frequency Shutdown Level	P5 Shutdown Freq	Sets the level used for the multiplex pumping operation. Parameter is active only when P3-02 is set to 0 or 2. Parameter function is similar to P3-50, except for Pump 5 instead of Pump 2.	Default: 40.0 Hz Min.: 0.0 Max.: 400.0	–
P3-90 (1203) <u>RUN</u>	Pump 6 Frequency Shutdown Level	P6 Shutdown Freq	Sets the level used for the multiplex pumping operation. Parameter is active only when P3-02 is set to 0 or 2. Parameter function is similar to P3-50, except for Pump 6 instead of Pump 2.	Default: 40.0 Hz Min.: 0.0 Max.: 400.0	–

<1> Unit is determined by P1-02, System Units, setting.

◆ P4: Pump Advanced

No. (Addr. Hex)	Name	LCD Display	Description	Values	Page
P4-01 (0CFA) <u>RUN</u>	Pre-Charge Level	Pre-Charge Level	Runs the drive at the frequency set in P4-02. The drive will stop when one of the following conditions occurs: <ul style="list-style-type: none"> The feedback level rises above the level set in P4-01 The pre-charge time set in P4-03 expires The low water digital input is deactivated (#8F) 	Default: 0.0 PSI </> Min.: 0.0 Max.: 6000.0	188
P4-02 (0CFB) <u>RUN</u>	Pre-Charge Frequency	Pre-Charge Freq.	Sets the frequency reference used when the Pre-Charge function is active.	Default: 0.0 Hz Min.: 0.0 Max.: [E1-04]	188

B.12 P: Pump Parameters

No. (Addr. Hex)	Name	LCD Display	Description	Values	Page
P4-03 (0CFC) 	Pre-Charge Time	Pre-Charge Time	Sets the maximum allowed pre-charge time. Setting this parameter to 0.0 disables the function.	Default: 0.0 min Min.: 0.0 Max.: 3600.0	188
P4-04 (0CFD)	Pre-Charge Message Style	Pre-Charge Msg 0: Full Screen Msg 1: Home Mon Text	Selects how the “Pre-charge Active” message is displayed on the operator. 0: Full Screen Message 1: Home Monitor Text	Default: 0 Range: 0, 1	191
P4-05 (0CFE) 	Pre-Charge Loss of Prime Level	Pre-Charge LOP	Detects loss of prime in the pump. When the measured quantity determined by P1-18 drops below this level for the time set in P1-20 and the output frequency is at the level set in P4-02, a “Loss of Prime” condition occurs. The drive responds to the “Loss of Prime” condition depending on the setting of P1-22, Loss of Prime Selection.	Default: 0.0 A <3> Min.: 0.0 Max.: 1000.0	–
P4-06 (0CFF) 	Pre-Charge Frequency 2	Pre-Charge Freq2	Sets the frequency reference used when the Pre-Charge function 2 is active. Setting this parameter to 0.0 disables the function.	Default: 0.0 Hz Min.: 0.0 Max.: [E1-04]	–
P4-07 (0D00) 	Pre-Charge Time 2	Pre-Charge Time2	Sets the time at which the drive will spend at the Pre-Charge frequency 2 speed during pre-charge. Setting this parameter to 0.0 disables the function.	Default: 0.0 min Min.: 0.0 Max.: 3600.0	–
P4-08 (0D01) 	Pre-Charge Loss of Prime Level 2	Pre-Charge LOP 2	Detects loss of prime in the pump. When the measured quantity determined by P1-18 drops below this level for the time set in P1-20 and the output frequency is at the level set in P4-06, a “Loss of Prime” condition occurs. The drive responds to the “Loss of Prime” condition depending on the setting of P1-22, Loss of Prime Selection.	Default: 0.0 A <3> Min.: 0.0 Max.: 1000.0	–
P4-10 (0D03) 	AUTO Mode Operator Run Power Down Storage	AUTO RunPwr Loss 0: Disabled 1: Enabled	Stores the run status in AUTO Mode when operating from the HOA keypad (b1-02 = 0). 0: Disabled 1: Enabled WARNING! Sudden Movement Hazard. If the drive is powered down while running, it will automatically initiate an internal Run command upon power-up.	Default: 0 Range: 0, 1	192
P4-11 (0D04) 	Thrust Bearing Acceleration Time	Thrust Acc. Time	Sets the time at which the drive output frequency will ramp up to the reference frequency set in P4-12.	Default: 1.0 s Min.: 0.0 Max.: 600.0	–
P4-12 (0D05) 	Thrust Bearing Frequency	Thrust Freq.	The drive will accelerate to this frequency in the time set to P4-11. The drive will decelerate from the frequency in the time set to P4-13. WARNING! Sudden Movement Hazard. If the drive is powered down while running, it will automatically initiate an internal Run command upon power-up.	Default: 30.0 Hz Min.: 0.0 Max.: [E1-04]	192
P4-13 (0D06) 	Thrust Bearing Deceleration Time	Thrust Dec Time	Sets the amount of time it takes to bring the drive from the Thrust Frequency set in P4-12 to stop when Thrust Mode is active. When the Run command is removed while the drive is operating in Thrust Mode above the Thrust Frequency, the time set in this parameter is used when the frequency reference is at or below the thrust frequency.	Default: 5.0 s Min.: 0.0 Max.: 600.0	–
P4-14 (0D07)	Two Motor Alternation Selection	2Motor Alternate 0: Disabled 1: Enabled 2: Motor 1 Only 3: Motor 2 Only	Enables and disables the alternation feature 0: Disable 1: Enable 2: Motor 1 Only 3: Motor 2 Only	Default: 0 Range: 0 to 3	–
P4-15 (0D08)	Two Motor Alternation Operation Selection	2Motor Alt Oper 0: Wait For Stop 1: Immediate	Determines drive behavior when the internal alternation timer expires. 0: Wait For Stop 1: Immediate (Auto mode only)	Default: 0 Range: 0, 1	–
P4-16 (0D09)	Two Motor Alternation Time	2Motor Alt Time	Sets the amount of time each motor will run before the drive switches to the other motor.	Default: 24.0 H Min.: 0.1 Max.: 100.0	–

No. (Addr. Hex)	Name	LCD Display	Description	Values	Page
P4-17 (0D0A) [RUN]	Utility Start Delay	Utility Delay	Sets the amount of time that the drive will delay starting if a Run command is present at power-up. Setting this parameter to 0.0 disables the function.	Default: 0.2 min Min.: 0.0 Max.: 1000.0	193
P4-18 (0D0B) [RUN]	Differential Level	Differential Lvl	Sets the maximum difference allowed between the PID Feedback and the Differential Feedback. The drive will respond based on the setting in P4-20 when the difference exceeds the value set in this parameter for the time set in P4-19.	Default: 10.0 PSI </> Min.: 0.0 Max.: 6000.0	-
P4-19 (0D0C) [RUN]	Differential Level Detection Time	Diff Lvl DetTime	Sets the amount of time that the difference between PID Feedback and the Differential Feedback must exceed the P4-18 value before responding based on the P4-20 value.	Default: 10 sec Min.: 0 Max.: 3600	-
P4-20 (0D0D)	Differential Level Detection Selection	Diff Lvl Det Sel 0: Fault 1: Alarm 2: Digital Output	Determines drive response during a “Differential Detected” condition. 0: Fault (and Digital Out) 1: Alarm (and Digital Out) 2: Digital Out Only	Default: 0 Range: 0 to 2	-
P4-21 (0D0E)	Low City Input Select	Low City In Sel 0: Normally Open 1: Normally Closed	Selects the type of pressure switch connected to the “Low City Press” digital input (H1-0□ = 73). 0: Normally open (closed indicates the Low City Pressure condition) 1: Normally closed (open indicates the Low City Pressure condition)	Default: 1 Range: 0, 1	-
P4-22 (0D0F) [RUN]	Low City On-Delay Time	Low City On Dly	Sets the amount of time a Low City Pressure condition needs to be present before the drive will stop.	Default: 10 s Min.: 1 Max.: 1000	-
P4-23 (0D10) [RUN]	Low City Off-Delay Time	Low City Off Dly	Sets the amount of time a Low City Pressure condition needs to be absent before the drive will restart.	Default: 5 s Min.: 0 Max.: 1000	-
P4-24 (0D11) [RUN]	Low City Alarm Text	Low City Alarm Txt 0: Low Cty Pressure 1: Low Suction Pres 2: Low Watr in Tank	Selects the alarm message that will be displayed when a Low City Pressure condition is detected. 0: Low city pressure 1: Low suction pressure 2: Low water in tank	Default: 0 Range: 0 to 2	-
P4-25 (0D12)	Remote Drive Disable Selection	Rem Drv Dis Sel 0: Normally Open 1: Normally Closed	Selects the type of pressure switch connected to the “Remote Drive Disable” digital input (H1-0□ = 95). 0: Normally open (closed indicates the Remote Drive Disable condition) 1: Normally closed (open indicates the Remote Drive Disable condition)	Default: 1 Range: 0, 1	-
P4-26 (0D13) [RUN]	Remote Drive Disable On-Delay	Drv Dis On-Delay	Sets the amount of time a Remote Drive Disable condition must be present before the drive will stop.	Default: 0 s Min.: 0 Max.: 1000	-
P4-27 (0D14) [RUN]	Remote Drive Disable Off-Delay	Drv Dis OffDelay	Sets the amount of time a Remote Drive Disable condition must be absent before the drive will run.	Default: 0 s Min.: 0 Max.: 1000	-
P4-29 (0D16) [RUN]	Lube Pump Message Text	Lube Pump MsgText 0: Lube Pump 1: DigitalOut Delay 2: Primer Pump 3: SreenMtrStarter	Selects which text is displayed when Lube Pump is active. Also changes the text for the Lube Pump Digital Output selection (H2-□□ = 8B) 0: Lube Pump 1: Digital Out Delay 2: Primer Pump 3: Screen Motor Starter	Default: 0 Range: 0 to 3	-
P4-30 (0D17)	Lube Pump Active During Run	Lube Pump DurRun 0: Disabled 1: Active DuringRun	When enabled, the Lube Pump digital output stays activated after the timer expires and the drive starts to run normally. The output is deactivated only when the drive stops, faults, or sleeps. 0: Disabled 1: Active During Run	Default: 0 Range: 0, 1	-
P4-31 (0D18) [RUN]	Lube Pump / Digital Output Delay Timer	Lube Pump Time	Sets the amount of time to delay the drive output and to energize the digital output (H2-□□ = 8B) before the drive is allowed to run. Setting this parameter to 0.0 disables the function.	Default: 0.0 s Min.: 0.0 Max.: 3000.0	-

B.12 P: Pump Parameters

No. (Addr. Hex)	Name	LCD Display	Description	Values	Page
P4-32 (0D19) <input type="checkbox"/> RUN	Pre-Charge Level 2	PreCharge Level2	For normal PI operation during Pre-Charge 2, if the PI Feedback signal rises above the P4-32 level, Pre-charge 2 is cancelled and the drive resumes normal operation. For inverse PI operation and during Pre-Charge 2, if the PI Feedback signal goes below the P4-32 level, Pre-charge 2 is cancelled and the drive resumes normal operation. When set to zero, Pre-charge 2 still runs when P4-07 is set, but uses P4-01 to determine if normal operation should resume.	Default: 0.0 PSI </> Min.: 0.0 Max.: 6000.0	–
P4-36 (0D1D) <input type="checkbox"/> RUN	Pressure Reached Exit Conditions	Pressure Reached 0: Hyst Above & Below 1: Hysteresis 1-Way	Determines Selects how the digital output reacts to Feedback changes after it activates. 0: Hysteresis Above and Below 1: Hysteresis One Way	Default: 1 Range: 0, 1	–
P4-37 (0D1E) <input type="checkbox"/> RUN	Pressure Reached Hysteresis Level	Press Reach Hyst	Sets the hysteresis level for exiting the Pressure Reached condition.	Default: 3.0 PSI </> Min.: 0.1 Max.: 100.0	–
P4-38 (0D1F) <input type="checkbox"/> RUN	Pressure Reached On-Delay Time	PressReach OnDly	Sets the delay time that is applied prior to activating the Pressure Reached condition.	Default: 1.0 s Min.: 0.1 Max.: 60.0	–
P4-39 (0D20) <input type="checkbox"/> RUN	Pressure Reached Off-Delay Time	PressReachOffDly	Sets the delay time that is applied prior to deactivating the Pressure Reached condition.	Default: 1.0 s Min.: 0.1 Max.: 60.0	–
P4-40 (0D21) <input type="checkbox"/> RUN	Pressure Reached Detection Selection	PressReachDetSel 0: Always 1: Drive Running 2: Run Command	Sets the value that the drive status must match to trigger the Pressure Detection digital output. 0: Always 1: Drive Running 2: Run Command	Default: 0 Range: 0 to 2	193

<1> Unit is determined by P1-02, System Units, setting.

<3> Unit text is set by P1-18, Prime Loss Detection Method.

◆ P5: Pump HAND Mode

No. (Addr. Hex)	Name	LCD Display	Description	Values	Page
P5-01 (0D2C) <input type="checkbox"/> RUN	HAND Mode Ref Source	Hand Mode 1 Src 0: Analog Input 1: Hand Ref 1 (OPR)	Sets the HAND Mode reference. 0: Analog input Note: Analog input is defaulted to input A3 (0-10 V). 1: P5-02 (HAND reference)	Default: 1 Range: 0, 1	–
P5-02 (0D2D) <input type="checkbox"/> RUN	HAND Reference 1	HAND Reference 1	Sets the frequency reference used when HAND Mode is active and P5-01 is set to 1.	Default: 40.0 Hz Min.: 0 Max.: [E1-04]	193
P5-03 (0D2E)	HAND/AUTO During Run Selection	HAND/AUTO @Run 0: Disabled 1: Enabled	Selects whether the drive will permit switching between HAND and AUTO Modes while running. 0: Disabled 1: Enabled	Default: 0 Range: 0, 1	–
P5-04 (0D2F)	HAND Key Function Selection	Oper HAND Key 0: Disabled 1: Enabled	Enables and disables the HAND key on the HOA keypad. 0: Disabled 1: Enabled	Default: 1 Range: 0, 1	193
P5-05 (0D30) <input type="checkbox"/> RUN	HAND Reference 2	HAND Reference 2	Sets the frequency reference used when HAND Mode 2 is active.	Default: 0.0 Hz Min.: 0.0 Max.: [E1-04]	–
P5-06 (0D31) <input type="checkbox"/> RUN	HAND Ref. 1 Loss of Prime Level	HandRef1 LOP Lvl	Detects loss of prime in the pump. When the measured quantity determined by P1-18 drops below this level for the time set in P1-20 and the output frequency is at the level set in P5-02, a “Loss of Prime” condition occurs. The drive responds to the “Loss of Prime” condition depending on the setting of P1-22, Loss of Prime Selection.	Default: 0.0 A </> Min.: 0.0 Max.: 1000.0	–

No. (Addr. Hex)	Name	LCD Display	Description	Values	Page
P5-07 (0D32) <input type="checkbox"/> RUN	HAND Ref. 2 Loss of Prime Level	HandRef2 LOP Lvl	Detects loss of prime in the pump. When the measured quantity determined by P1-18 drops below this level for the time set in P1-20 and the output frequency is at the level set in P5-05, a “Loss of Prime” condition occurs. The drive responds to the “Loss of Prime” condition depending on the setting of P1-22, Loss of Prime Selection.	Default: 0.0 A </> Min.: 0.0 Max.: 1000.0	–
P5-09 (0D34)	HAND References Set via Motor Operated Pot Selection	Hand MOP Sel 0: Disabled 1: Enabled	Selects whether parameters P5-02 and P5-05 are changed via MOP from the home screen. 0: Disabled 1: Enabled	Default: 0 Range: 0, 1	–

<1> Unit text is set by P1-18, Prime Loss Detection Method.

◆ P6: Flow Meter Setup

No. (Addr. Hex)	Name	LCD Display	Description	Values	Page
P6-01 (0D5E)	Flow Meter Scaling	Flow Meter Scale	When an analog input is used for the flow rate, this parameter performs the following functions: <ul style="list-style-type: none"> Enables and disables flow meter functions. This parameter must be set to a value greater than 0 to enable flow meter functions. Sets the scaling for the “Flow Rate” analog input. Sets the scaling for the “Flow Rate” analog output. Sets the display scaling when “Flow Rate” is used as the PID feedback. When an pulse input is used for the flow rate, this parameter performs the following functions: <ul style="list-style-type: none"> Enables and disables flow meter functions. Parameter must be set to a value greater than zero to enable flow meter functions. Sets the scaling for the “Flow Rate” analog output. Sets the display scaling when “Flow Rate” is used as the PID feedback. 	Default: 0.0 GPM </> Min.: 0.0 Max.: 6000.0	–
P6-02 (0D5F) <input type="checkbox"/> RUN	Turbine Input Scaling (Coarse)	Turbine Scale 1	Sets the scaling for the turbine in pulses per gallon. Pulses/Gallon = P6-02 + P6-03 This parameter is internally lower-limited to 0.0001 ppG.	Default: 1 ppG Min.: 0 Max.: 6000	–
P6-03 (0D60) <input type="checkbox"/> RUN	Turbine Input Scaling (Fine)	Turbine Scale 2		Default: 0.0000 ppG Min.: 0.0000 Max.: 0.9999	–
P6-04 (0D61)	Water Flow Units	Water Flow Units 0: Gal/Min (GPM) 1: Gal/Hr (GPH) 2: Ft3/Min (CFM) 3: M3/Hr (CMH) 4: Acre-Ft/Yr (AFY)	Sets the display units for monitor U1-83, P2-02, P6-06, and P6-17. 0: U.S. Gallons / min (GPM) 1: U.S. Gallons / hr (GPH) 2: Cubic Feet / min (CFM) 3: Cubic Meters / hr (CMH) 4: Acre-Feet / yr (AFY)	Default: 0 Range: 0 to 4	–
P6-05 (0D62) <input type="checkbox"/> RUN	Flow Accumulation Reset	Flow Accum Reset	Resets the accumulated flow and returns monitors U1-96 and U1-97 to 0. 0: No reset 7770: Reset accumulation 8880: Set Accumulation (P6-31 to P6-34) All other settings have no effect. Note: After this parameter is changed, the setting will automatically return to “0”.	Default: 0 Min.: 0 Max.: 65535	–
P6-06 (0D63) <input type="checkbox"/> RUN	Low Flow Level	Low Flow Level	Sets the level below which the flow must fall for longer than the time set in P6-07 to trigger a Low Flow condition. Setting this parameter to 0.0 will disable the function.	Default: 0.0 GPM </> </> Min.: 0.0 Max.: 6000.0	–

B.12 P: Pump Parameters

No. (Addr. Hex)	Name	LCD Display	Description	Values	Page
P6-07 (0D64) <input type="checkbox"/> RUN	Low Flow Detection Delay Time When Already Running	Low Flow Tim Run	Sets the length of time that the flow rate must be below the level set in P6-06 to detect a Low Flow condition.	Default: 10 s Min.: 0 Max.: 6000	–
P6-08 (0D65) <input type="checkbox"/> RUN	Low Flow Detection Wait Time at Start	Low Flow Time St	Sets the length of time that the drive will wait after coming out of a zero speed condition before activating Low Flow detection. Note: This feature is canceled when the Flow Rate rises above the Low Flow Level for the time set in P6-21, Low Flow Start Delay Cancel Time.	Default: 0.0 min Min.: 0.0 Max.: 3600.0	–
P6-09 (0D66)	Low Flow Select	Low Flow Sel 0: No Display 1: Alarm Only 2: Fault 3: Restart (P6-10)	Determines drive response when a Low Flow condition is detected. 0: No display 1: Alarm only 2: Fault 3: Auto-restart (time set by P6-10)	Default: 1 Range: 0 to 3	–
P6-10 (0D67)	Low Flow Auto-Restart Time	LowFlow Restart	Set the length of time that the drive will wait before attempting an auto-restart of the Low Flow fault. This parameter is effective only when P6-09 is set to 3.	Default: 3.0 min Min.: 0.1 Max.: 6000.0	–
P6-11 (0D68) <input type="checkbox"/> RUN	Accumulation Level - Millions	AccumLvl*1000000	Sets the accumulated volume that will trigger the Accum Level alarm, Accum Level fault, or the Accum Level digital output. Accum Level is calculated using the following formula: Level = (P6-11 * 1000000) + (P6-12 * 1000) + P6-13 + P6-14)	Default: 0 gal <2>	–
P6-12 (0D69) <input type="checkbox"/> RUN	Accumulation Level - Thousands	AccumLvl*1000		Default: 0 gal <2>	194
P6-13 (0D6A) <input type="checkbox"/> RUN	Accumulation Level - Ones	AccumLvl*1		Default: 0 gal <2>	–
P6-14 (0D6B) <input type="checkbox"/> RUN	Accumulation Level - Decimal	AccumLvl*0.0001		Default: 0.0000 gal <2>	–
P6-15 (0D6C) <input type="checkbox"/> RUN	Accumulation Behavior	Accum Behavior 0: No Display 1: Alarm Only 2: Fault 3: Fault-ResetAccum 4: Stop & Alarm 5: Stp/Alm/RstAccum	Determines drive response when the accumulated volume reaches the P6-11 to P6-14 level. 0: No display 1: Alarm only 2: Fault 3: Fault - Auto flow accum reset 4: Stop and alarm 5: Stop, alarm, and reset flow accumulation	Default: 1 Range: 0 to 5	194
P6-16 (0D6D)	Flow Meter Accumulator Units Select	Accum Units 1: Gallons (gal) 2: Acre-Feet (A-F)	Selects whether the drive accumulates flow in gallons or acre-feet. 1: Gallons (gal) 2: Acre-feet Note: Changing this parameter resets the accumulated flow (U1-84 to U1-87) to zero.	Default: 1 Range: 1, 2	–
P6-17 (0D6E) <input type="checkbox"/> RUN	High Flow Level	High Flow Level	Sets the level above which the flow must rise for the time set in P6-18 to trigger a High Flow condition.	Default: 0.0 GPM <1> <4> Min.: 0.0 Max.: 6000.0	194
P6-18 (0D6F) <input type="checkbox"/> RUN	High Flow Detection Delay Time	High Flow Time	Sets the length of time that the flow rate must be above the level set in P6-17 to detect a High Flow condition.	Default: 10 s Min.: 0 Max.: 6000	–
P6-19 (0D70)	High Flow Select	High Flow Sel 0: No Display 1: Alarm Only 2: Fault 3: Restart (L5-04)	Sets drive behavior when a High Flow condition is detected. 0: No display 1: Alarm only 2: Fault 3: Auto-restart (time set by L5-04)	Default: 1 Range: 0 to 3	194
P6-20 (0D71)	Accumulator Stopping Method Selection	Accum Stop Sel 0: Ramp to Stop 1: Coast to Stop 2: Fast-Stop	Selects how the drive stops when the Flow Accumulator has reached its target level (P6-11 to P6-14). Effective only when P6-15 (Accum Behavior) is set for Fault or Stop (selections 2 to 5).	Default: 1 Range: 0 to 2	–

No. (Addr. Hex)	Name	LCD Display	Description	Values	Page
P6-21 (0D72) <input type="checkbox"/> RUN	Low Flow Detection Delay @ Start Cancel Time	LoFloStartDlyOff	Sets the amount of time that the flow rate must rise above the Low Flow Level (P6-06) to cancel the Low Flow Detection Delay Time at Start (P6-08) and activate Low Flow Detection.	Default: 5 s Min.: 0 Max.: 6000	–
P6-22 (0D73)	Flow Meter Decimal Place Position	Flow Meter DecPt 0: No Dec (XXXXX) 1: 1 Dec (XXXX.X) 2: 2 Dec (XXX.XX)	Sets the number of decimal places for the Flow Meter parameters and monitor: 0: No Dec (XXXXX) 1: 1 Dec (XXXX.X) 2: 2 Dec (XXX.XX)	Default: 1 Range: 0 to 2	–
P6-25 (0D76)	Flow Rate Limit Foldback Message Style	Flow Lim Msg 0: Full Screen Msg 1: Home Mon Text	Selects how the “Flow Rate Limit Foldback” message is displayed on the operator. 0: Full Screen Message 1: Home Monitor Text	Default: 0 Range: 0, 1	194
P6-26 (0D77)	Flow Limit Selection	Flow Limit Sel 0: Disabled 1: Enabled 2: Enabled – Low Limit	Enables and disables the Flow Rate Limiter. 0: Disabled 1: Enabled 2: Enabled – Low Limit	Default: 0 Range: 0 to 2	–
P6-27 (0D78) <input type="checkbox"/> RUN	Flow Limit Level	Flow Limit Level	Sets the Flow Rate Limit. When P6-26 = 1, the drive reduces speed when the Flow Rate increases rapidly or exceeds this level (PI control). When P6-26 = 2, the drive reduces speed when the Flow Rate decreases rapidly or goes below this level (PI control).	Default: 0.0 GPM Min.: 0.0 Max.: 6000.0	–
P6-28 (0D79) <input type="checkbox"/> RUN	Flow Limit Regulator Gain	Flow Limit Gain	Sets the responsiveness of the Flow Rate limit regulator. Increasing the setting increases the responsiveness.	Default: 1.00 Min.: 0.00 Max.: 25.00	–
P6-29 (0D7A) <input type="checkbox"/> RUN	Flow Limit Regulator Integral Time	Flow Lim I Time	Sets the responsiveness of the Flow Rate limit regulator. Reducing the setting increases the responsiveness.	Default: 1.00 s Min.: 0.00 Max.: 10.00	–
P6-30 (0D7B) <input type="checkbox"/> RUN	Flow Limit Regulator Delay @ Start	FlowLimStartDly	Sets the amount of time Flow Rate Limiter activates after the drive has run for the amount of time set.	Default: 10 s Min.: 0 Max.: 6000	–
P6-31 (0D7C) <input type="checkbox"/> RUN	Set Accumulation Level - Millions	SetAccumLvl*1000000	Parameters P6-31 to P6-34 set the stored accumulated volume. Level = (P6-31 * 1000000) + (P6-32 * 1000) + P6-33 + P6-34. Value is accepted when P6-05 = 8880, after which it resets to 0.	Default: 0 Min.: 0 Max.: 65535	–
P6-32 (0D7D) <input type="checkbox"/> RUN	Set Accumulation Level - Thousands	SetAccumLvl * 1000		Default: 0 Min.: 0 Max.: 999	–
P6-33 (0D7E) <input type="checkbox"/> RUN	Set Accumulation Level - Ones	SetAccumLvl * 1		Default: 0 Min.: 0 Max.: 999	–
P6-34 (0D7F) <input type="checkbox"/> RUN	Set Accumulation Level - Decimal	SetAccumLvl *0.0001		Default: 0.0000 Min.: 0.0000 Max.: 0.9999	–
P6-35 (0D80) <input type="checkbox"/> RUN	Accumulator Delta Save Selection	Accum Delta Save 0: - - 1: Set 2: Reset	Sets and resets the starting value used to calculate the Accumulation Delta monitor U1-89. 0: - - 1: Set 2: Reset Note: This parameter returns to 0 after the selected action is performed.	Default: 0 Range: 0 to 2	–

B.12 P: Pump Parameters

No. (Addr. Hex)	Name	LCD Display	Description	Values	Page
P6-36 (0D81) <input type="checkbox"/> RUN	Delta Starting Accumulation Level - Millions	DeltaVol*1000000	Parameters P6-36 to P6-39 set the starting values used for the Accumulation Delta monitor U1-89. Level = (P6-36 * 1000000) + (P6-37 * 1000) + P6-38 + P6-39. Setting P6-35 to 1 will overwrite the values by the current accumulation values as displayed by U1-84 to U1-87 (or U1-88). Setting P6-35 to 2 resets all values to 0.	Default: 0 gal <2> Min.: 0 Max.: 65535	-
P6-37 (0D82) <input type="checkbox"/> RUN	Delta Starting Accumulation Level - Thousands	DeltaVol * 1000		Default: 0 gal <2> Min.: 0 Max.: 999	-
P6-38 (0D83) <input type="checkbox"/> RUN	Delta Starting Accumulation Level - Ones	DeltaVol * 1		Default: 0 gal <2> Min.: 0 Max.: 999	-
P6-39 (0D84) <input type="checkbox"/> RUN	Delta Starting Accumulation Level - Decimal	DeltaVol * 0.0001		Default: 0.0000 gal <2> Min.: 0.0000 Max.: 0.9999	-

<1> Unit text is set by P6-04, Water Flow Units.

<2> Unit text is set by P6-16, Flow Meter Accumulator Units Select.

<4> Resolution is set by P6-22, Flow Meter Decimal Place Position.

◆ P7: Anti-Jam

No. (Addr. Hex)	Name	LCD Display	Description	Values	Page
P7-01 (0D90)	Anti-Jam Operation Selection	Anti-Jam Sel 0: Disabled 1: Enabled	Enables and disables the anti-jam function. 0: Disabled 1: Enabled	Default: 0 Range: 0, 1	-
P7-02 (0D91) <input type="checkbox"/> RUN	Anti-Jam Cycle Count	AJ Cycle Count	Sets the maximum number of cycles that will be attempted before triggering and Anti-Jam fault.	Default: 1 Min.: 1 Max.: 100	-
P7-03 (0D92) <input type="checkbox"/> RUN	Anti-Jam Detection Current Level	AJ Det I @Start	Sets the current level at start that will trigger the anti-jam function. Set as a percentage of the motor rated current.	Default: 120% Min.: 50 Max.: 200	-
P7-04 (0D93) <input type="checkbox"/> RUN	Anti-Jam Detection Time at Start	AJ Det Tm@Start	Sets the length of time that current must rise above the level set in P7-03 to trigger the anti-jam function.	Default: 0.3 s Min.: 0.1 Max.: 2.0	-
P7-05 (0D94) <input type="checkbox"/> RUN	Anti-Jam During Run Current	AJ Det I @Run	Sets the current level during run that will trigger the anti-jam function. Set as a percentage of motor rated current. Setting this parameter to 0 will disable anti-jam during run.	Default: 0% Min.: 0 Max.: 200	-
P7-06 (0D95) <input type="checkbox"/> RUN	Anti-Jam During Run Time	AJ Det Tm @Run	Sets the length of time that the current must rise above the level set in P7-05 to trigger the anti-jam function. Restricted to simplex only.	Default: 0.3 s Min.: 0.1 Max.: 2.0	-
P7-07 (0D96) <input type="checkbox"/> RUN	Anti-Jam Frequency Reference	AJ Freq Ref	Sets the maximum speed allowed when the anti-jam function is active.	Default: 25.00 Hz Min.: 0.00 Max.: 400.00	-
P7-08 (0D98) <input type="checkbox"/> RUN	Anti-Jam Release Time	AJ Release Time	Sets the length of time that the current must fall below the level set in P7-03 to resume normal operation.	Default: 2.0 s Min.: 0.5 Max.: 10.0	-

◆ P8: De-Scale / De-Ragging

No. (Addr. Hex)	Name	LCD Display	Description	Values	Page
P8-01 (0DB0)	De-scale Operation Selection	De-scale Sel	Selects de-scale functionality. 0: Disabled 1: De-scale Enabled 2: Force De-scale	Default: 0 Range: 0 to 2	–
P8-02 (0DB1) <input type="checkbox"/> RUN	De-scale Cycle Count	De-scale Cycles	Sets the maximum number of cycles attempted before the Anti-Jam fault occurs. Also sets the number of fwd/rev cycles for the De-scale function.	Default: 1 Min.: 1 Max.: 100	–
P8-03 (0DB2) <input type="checkbox"/> RUN	De-scale Frequency Reference	De-scale FreqRef	Sets the speed during the de-scale operation.	Default: 25.00 Hz Min.: 0.00 Max.: 400.00	–
P8-04 (0DB3) <input type="checkbox"/> RUN	De-scale Forward Run Time	De-scale FWD Run	Sets the amount of time the drive will run in the forward direction each cycle during the de-scale function.	Default: 10 s Min.: 1 Max.: 6000	–
P8-05 (0DB4) <input type="checkbox"/> RUN	De-scale Reverse Run Time	De-scale REV Run	Sets the amount of time the drive will run in the reverse direction each cycle during the de-scale function.	Default: 10 s Min.: 1 Max.: 6000	–
P8-06 (0DB5) <input type="checkbox"/> RUN	De-scale Acceleration Time	De-scale Accel	Sets the amount of time it will take the drive to accelerate from zero to the De-scale frequency reference P8-03.	Default: 2.0 s Min.: 0.0 Max.: 600.0	–
P8-07 (0DB6) <input type="checkbox"/> RUN	De-scale Deceleration Time	De-scale Decel	Sets the amount of time it will take the drive to decelerate from the De-scale frequency reference P8-03 to zero.	Default: 2.0 s Min.: 0.0 Max.: 600.0	–
P8-08 (0DB7) <input type="checkbox"/> RUN	De-scale Pump Run Time	De-Scale Time	Sets the number of pump operating hours (pump speed > 0) before a de-scale routine will run.	Default: 168.0 H Min.: 0.1 Max.: 2000.0	–
P8-09 (0DB8) <input type="checkbox"/> RUN	De-scale Reverse Frequency Reference	Descale REV FRef	Sets the reverse speed during the de-scale operation.	Default: 25.00 Hz Min.: 0.00 Max.: 400.00	–

B.13 Q: PID Controller Parameters

◆ Q1: Preset Setpoint

No. (Addr. Hex)	Name	LCD Display	Description	Values	Page
Q1-01 (0E58) <input type="button" value="RUN"/>	PID Controller Setpoint 1	Setpoint 1	Sets the PID Setpoint when b1-01 is set to 0.	Default: 0.0 Min.: 0.0 Max.: 6000.0 </>	195
Q1-02 (0E59) <input type="button" value="RUN"/>	PID Controller Setpoint 2	Setpoint 2	Sets the PID Setpoint when the "Multi Setpoint 1" or "Alternate Multi Setpoint 1" multi-function digital input is closed.	Default: 0.0 Min.: 0.0 Max.: 6000.0 </>	-
Q1-03 (0E5A) <input type="button" value="RUN"/>	PID Controller Setpoint 3	Setpoint 3	Sets the PID Setpoint when the "Multi Setpoint 2" or "Alternate Multi Setpoint 2" digital input is closed.	Default: 0.0 Min.: 0.0 Max.: 6000.0 </>	-
Q1-04 (0E5B) <input type="button" value="RUN"/>	PID Controller Setpoint 4	Setpoint 4	Sets the PID Setpoint when the "Multi Setpoint 1" and "Multi Setpoint 2" or "Alternate Multi Setpoint 3" multi-function digital inputs are closed.	Default: 0.0 Min.: 0.0 Max.: 6000.0 </>	-
Q1-09 (0E60)	PID Setpoint Set via Motor Operated Pot	Setpoint MOP 0: Disabled 1: Enabled	Selects whether parameters Q1-01 to Q1-04 are changed via MOP from the home screen. 0: Disabled 1: Enabled	Default: 0 Range: 0, 1	-

</> Unit text is set by P1-02, System Units. Scaling is set by P1-03, Feedback Device Scaling.

◆ Q3: Output Current Limit

No. (Addr. Hex)	Name	LCD Display	Description	Values	Page
Q3-01 (0EBC)	Output Current Limit Select	Current Lim Sel 0: Disabled 1: Enabled	Enables and disables the output current regulator. 0: Disabled 1: Enabled	Default: 0 Range: 0, 1	-
Q3-02 (0EBD) <input type="button" value="RUN"/>	Current Limit	Current Limit	Sets the current limit. Value is internally limited to 300% of the drive rated current.	Default: 0.0 A Min.: 0.0 Max.: 1000.0	-
Q3-05 (0EC0)	Current Limit Regulator Feedback Filter	Feedback Filter	First order filter time on the feedback used for Current Limit control.	Default: 1000 ms Min.: 5 Max.: 10000	-
Q3-06 (0EC1)	Current Limit Foldback Message Style	Current Lim Msg 0: Full Screen Msg 1: Home Mon Text	Selects how the "Current Limit Foldback" message is displayed on the operator. 0: Full Screen Message 1: Home Monitor Text	Default: 0 Range: 0, 1	195

◆ Q4: Water Level Control

No. (Addr. Hex)	Name	LCD Display	Description	Values	Page
Q4-01 (0EEE)	Water Level Selection	Water Level Sel 0: Disabled 1: Enabled	Enables and disables the water level control. 0: Disabled 1: Enabled	Default: 0 Range: 0, 1	-
Q4-02 (0EEF) <input type="button" value="RUN"/>	Water Level Scaling	Water Lvl Scale	Sets the full scale (20 mA) output of the pressure transducer that is connected to the analog input terminal programmed for "WaterLvl/Suction" (H3-□□ = 23). Note: 1 PSI = 2.308 feet of water	Default: 100 PSI </> Min.: 5 Max.: 500	-

No. (Addr. Hex)	Name	LCD Display	Description	Values	Page
Q4-03 (0EF0) RUN	Water Level Setpoint	Water Lvl Setpnt	Sets the amount of water above the sensor to which the drive will attempt to regulate.	Default: 20.0 ft Min.: 0.0 Max.: 1200.0	–
Q4-04 (0EF1) RUN	Minimum Water Level	Min Water Level	Sets the level below which the amount of water must drop for the time set in Q4-05 to put the drive to sleep.	Default: 10.0 ft Min.: 0.0 Max.: 1200.0	–
Q4-05 (0EF2) RUN	Water Level Sleep Delay Time	WL Sleep Dly Tm	Sets the length of time that the drive will delay after the water level drops below the level set in Q4-04 before going to sleep.	Default: 5 s Min.: 0 Max.: 3600	–
Q4-06 (0EF3) RUN	Wake-Up Water Level	Wake-Up Level	Sets the level above which the water needs to rise for more than the time set in Q4-07 for the drive to wake up after being put to sleep via parameter Q4-04, Minimum Water Level.	Default: 30.0 ft Min.: 0.0 Max.: 1200.0	–
Q4-07 (0EF4)	Water Level Control Sleep Wake-Up Time	WL Wake-up Time	Sets the length of time that the water level set in Q4-06 must be met for the drive to wake up after being put to sleep via parameter Q4-04, Minimum Water Level.	Default: 1 s Min.: 0 Max.: 3600	–
Q4-08 (0EF5) RUN	Level Control Minimum Speed	Level Min Spd	Sets the minimum speed at which the drive will run when the drive is controlling the water level. When the drive is controlling pressure or if this parameter is set less than P1-06 and P4-12, parameters P1-06 and P4-12 will be used as the minimum speed.	Default: 0.00 Hz Min.: 0.00 Max.: 400.00	–
Q4-09 (0EF6) RUN	Low Level Detection Level	Low Level Detect	Sets the level below which the water level must drop for the time set in Q4-10 to trigger the drive response set in Q4-11. Setting this parameter to 0.0 will disable the function. Note: Q4-10 detection time delay is only applicable when Q4-11 = 2 or 3.	Default: 0.0 ft Min.: 0.0 Max.: 1200.0	–
Q4-10 (0EF7) RUN	Low Level Detection Time Delay	Low Lvl Det Tm	Sets the length of time that the water level must fall below the level set in Q4-09 to trigger the drive to respond. Applicable when Q4-11 = 2 or 3.	Default: 0.0 ^{<2>} Min.: 0.0 Max.: 300.0	–
Q4-11 (0EF8)	Low Level Behavior	Low Lvl Behavior 0: No Display 1: Alarm Only 2: Fault 3: Restart (Q4-12)	Selects drive response when the water level drops below the level set in Q4-09 for the time set in Q4-10. 0: No display (digital output only) 1: Alarm only 2: Fault 3: Restart (time set by Q4-12) Note: Q4-10 detection time delay is only applicable to settings 2 and 3.	Default: 1 Range: 0 to 3	–
Q4-12 (0EF9)	Water Level Control Auto-Restart Time	WtrLvl Restart	Sets the length of time that the drive will wait before attempting an auto-restart of the Low Water Level fault. This parameter is effective only when Q4-11 is set to 3 and L5-01 is set to a value greater than 0.	Default: 5.0 min Min.: 0.1 Max.: 6000.0	–
Q4-13 (0EFA) RUN	Level Control Proportional Gain	Lvl Ctrl P Gain	Sets the proportional gain for the water level control.	Default: 2.00 Min.: 0.00 Max.: 25.00	–
Q4-14 (0EFB) RUN	Level Control Integral Time	Lvl Ctrl I Time	Sets the integral time for the water level control. Setting this parameter to 0.0 disables the water level control integrator.	Default: 5.0 s Min.: 0.0 Max.: 360.0	–
Q4-15 (0EFC)	Low Water Level Detection Time Unit	Low Lvl Det Unit 0: Minutes (min) 1: Seconds (sec)	Determines the time unit for Q4-10, Low Level Detection Time Delay. 0: Minutes (min) 1: Seconds (sec)	Default: 0 Range: 0, 1	–
Q4-16 (0EFD)	Water Level Analog Input Wire-Break Detection	WL Wire Break 0: No Display 1: Alarm Only 2: Fault	Sets the behavior when the analog input selected for water level feedback is programmed to receive a 4-20 mA signal and the signal is lost. 0: No display 1: Alarm only 2: Fault (no retry, coast to stop)	Default: 2 Range: 0 to 2	–
Q4-20 (0F02)	Water Level Speed Control I	WaterLvl SpdCtrl 0: Disabled 1: Enabled	Selects whether the Water Level Controller has an effect on output speed. 0: Disabled 1: Enabled	Default: 1 Range: 0, 1	–

B.13 Q: PID Controller Parameters

No. (Addr. Hex)	Name	LCD Display	Description	Values	Page
Q4-22 (0F04)	Water Level Decimal Place Position	Water Lvl Dec Pt	Sets the number of decimal places for the Water Level parameters and monitor: 0: No Dec (XXXXX) 1: 1 Dec (XXXX.X) 2: 2 Dec (XXX.XX) 3: 3 Dec (XX.XXX)	Default: 1 Range: 0 to 3	–
Q4-25 (0F07)	Water Level Control Activation Level	WaterLvl Act Lvl	When the amount of water above the sensor drops below this level for more than the Q4-26 time, Water Level Control is activated allowing it to affect the output frequency. When the amount of water below the sensor rises above this level for more than the Q4-26 time, Water Level Control is deactivated causing it to have no effect on the output frequency. Water Level Control is always active (if enabled) when set to 0.	Default: 0.0 ft. Range: 0.0 to 1200.0	–
Q4-26 (0F08)	Water Level Control Activation/ Deactivation Delay	WaterLvl Act Dly	When the amount of water above the sensor drops below the Q4-25 level for more than this time, Water Level Control is activated allowing it to affect the output frequency. When the amount of water below the sensor rises above the Q4-25 level for more than this time, Water Level Control is deactivated causing it to have no effect on the output frequency.	Default: 2 s Range: 0 to 3600	–

<1> Resolution depends on parameter Q4-22, Water Level Decimal Place Position.

<2> Units are determined by Q4-15, Low Water Level Detection Time Unit, setting.

◆ Q5: Suction Pressure Control

No. (Addr. Hex)	Name	LCD Display	Description	Values	Page
Q5-01 (0F20)	Suction Pressure Select	Suction Pres Sel 0: Disabled 1: Suction Pressure 2: Vacuum ("Hg)	Sets the method of operation for the Suction Control / Vacuum Control function. 0: Disabled 1: Suction pressure (PSI) 2: Vacuum ("Hg)	Default: 0 Range: 0 to 2	–
Q5-02 (0F21) <input type="checkbox"/> RUN	Suction Transducer Scaling	Suction Scaling	Sets the full scale (20 mA) output of the pressure transducer that is connected to the analog input terminal programmed for "WaterLvl/Suction" (H3-0□ = 23).	Default: 100.0 <1> Min.: 5.0 Max.: 1200.0	–
Q5-03 (0F22) <input type="checkbox"/> RUN	Suction Pressure Setpoint	Suction Setpoint	Sets the amount of suction pressure to which the drive will attempt to regulate.	Default: 20.0 <1> Min.: 0.0 Max.: 1200.0	195
Q5-04 (0F23) <input type="checkbox"/> RUN	Minimum Suction Pressure	Min Suction Pres	Sets the level below which the suction pressure must fall for longer than the Q5-05 time to put the drive to sleep and turn off all lag pumps.	Default: 10.0 <1> Min.: 0.0 Max.: 1200.0	–
Q5-05 (0F24) <input type="checkbox"/> RUN	Suction Pressure Sleep Delay Time	SP Sleep Dly Tm	Sets the length of time that the drive will delay after suction pressure drops below the level set in Q5-04 before going to sleep.	Default: 5 s Min.: 0 Max.: 3600	–
Q5-06 (0F25) <input type="checkbox"/> RUN	Wake-Up Suction Pressure	Wake-Up Pres	Sets the level above which the suction pressure must rise for the time set in Q5-07 for the drive to wake up when it has been put to sleep via parameter Q5-04, Minimum Suction Pressure.	Default: 30.0 <1> Min.: 0.0 Max.: 1200.0	196
Q5-07 (0F26)	Suction Pressure Sleep Wake-Up Time	SP Wake-up Time	Sets the length of time for which the pressure must rise above the level set in Q5-06 to wake up the drive when it has been put to sleep via parameter Q5-04, Minimum Suction Pressure.	Default: 1 s Min.: 0 Max.: 3600	–
Q5-08 (0F27) <input type="checkbox"/> RUN	Suction Pressure Control Minimum Speed	Suction Min Spd	Sets the minimum speed at which the drive will run when the drive is controlling suction pressure. When the drive is controlling outlet pressure or this parameter is set lower than P1-06 and P4-12, parameters P1-06 and P4-12 will be used as the minimum speed.	Default: 0.00 Hz Min.: 0.00 Max.: 400.00	–

No. (Addr. Hex)	Name	LCD Display	Description	Values	Page
Q5-09 (0F28) <input type="checkbox"/> RUN	Low Suction Pressure Detection Level	Low Pres Detect	Sets the level below which the suction pressure must fall for the time set in Q5-10 to trigger a drive response according to Q5-11, Low Suction Pressure Behavior Select. Setting this parameter to 0.0 will disable the function. Note: Q4-10 detection time delay is only applicable when Q4-11 = 2 or 3. When Q5-01 = 2, Q5-10 detection time delay applies to settings 1, 2, and 3.	Default: 0.0 <1> Min.: 0.0 Max.: 1200.0	196
Q5-10 (0F29) <input type="checkbox"/> RUN	Low Suction Pressure Detection Time	Low Pres Det Tm	Sets the length of time that the water level must fall below the level set in Q5-09 to trigger drive response. Applicable when Q5-11 = 2 or 3. When Q5-01 = 2, Q5-10 detection time delay applies to Q5-11 settings 1, 2, and 3.	Default: 0.1 <2> Min.: 0.0 Max.: 300.0	196
Q5-11 (0F2A)	Low Suction Pressure Behavior Select	Low Pressure Sel 0: No Display 1: Alarm Only 2: Fault 3: Restart (Q5-15)	Determines drive response when the suction pressure drops below the level set in Q5-09 for longer than the time set in Q5-10. 0: No display (digital output only) 1: Alarm only 2: Fault 3: Auto-restart (time set by Q5-15) Note: Q5-10 detection time delay only applies to settings 2 and 3 while Q5-01 = 1. When Q5-01 = 2, Q5-10 detection time delay applies to settings 1, 2, and 3.	Default: 1 Range: 0 to 3	196
Q5-12 (0F2B) <input type="checkbox"/> RUN	High Suction Pressure Detection Level	Hi Pres Detect	Sets the level above which the suction pressure must rise for the time set in Q5-13 to trigger a drive response according to Q5-14. Setting this parameter to 0.0 disables the function. Note: Q5-13 detection time delay only applies when Q5-14 = 2 or 3.	Default: 0.0 <1> Min.: 0.0 Max.: 1200.0	-
Q5-13 (0F2C) <input type="checkbox"/> RUN	High Suction Pressure Detection Time	Hi Pres Det Tm	Sets the length of time that the water level must rise above the level set in Q5-12 to trigger drive response. Applicable when Q5-14 = 2 or 3.	Default: 0.1 <2> Min.: 0.0 Max.: 300.0	-
Q5-14 (0F2D)	High Suction Pressure Behavior Select	Hi Pressure Sel 0: No Display 1: Alarm Only 2: Fault 3: Restart (Q5-15)	Determines drive response when the suction pressure rises above the level set in Q5-12 for longer than the time set in Q5-13. 0: No display 1: Alarm only 2: Fault 3: Auto-restart (time set by Q5-15) Note: Q5-13 detection time delay only applies to settings 2 and 3.	Default: 1 Range: 0 to 3	-
Q5-15 (0F2E)	Suction Pressure Auto-Restart Time	Suction Restart	Sets the length of time that the drive will wait before attempting an auto-restart of the Low Suction or High Suction fault. Parameter is only effective when Q5-11 is set to 3 or Q5-14 is set to 3 and L5-01 is greater than 0.	Default: 5.0 min Min.: 0.1 Max.: 6000.0	-
Q5-16 (0F2F) <input type="checkbox"/> RUN	Suction Control Proportional Gain	Suction P Gain	Sets the proportional gain for the suction pressure control.	Default: 2.00 Min.: 0.00 Max.: 25.00	196
Q5-17 (0F30) <input type="checkbox"/> RUN	Suction Control Integral Time	Suction I Time	Sets the integral time for the suction pressure control. Setting this parameter to 0.0 disables the suction pressure control integrator.	Default: 5.0 s Min.: 0.0 Max.: 360.0	196
Q5-18 (0F31)	Suction Pressure Detection Time Unit	SuctionPresUnit 0: Minutes (min) 1: Seconds (sec)	Sets the time unit for Q5-10 and Q5-13. 0: Minutes (min) 1: Seconds (sec)	Default: 0 Range: 0, 1	-
Q5-19 (0F32)	Suction Pressure Analog Input Wire-Break Detection	SP Wire Break 0: No Display 1: Alarm Only 2: Fault	Sets the behavior when the analog input selected for suction pressure feedback is programmed to receive a 4 to 20 mA signal and the signal is lost. 0: Disabled 1: Alarm only 2: Fault (no retry, coast to stop)	Default: 2 Range: 0 to 2	-
Q5-20 (0F36)	Suction Pressure Speed Control	SucPres Spd Ctrl 0: Disabled 1: Enabled	Selects whether the Suction Pressure Controller has an effect on output speed. 0: Disabled 1: Enabled	Default: 1 Range: 0, 1	-

B.13 Q: PID Controller Parameters

No. (Addr. Hex)	Name	LCD Display	Description	Values	Page
Q5-22 (0F38)	Suction Pressure Decimal Place Position	Suc Press Dec Pt 0: No Dec (XXXXXX) 1: 1 Dec (XXXX.X) 2: 2 Dec (XXX.XX) 3: 3 Dec (XX.XXX)	Sets the number of decimal places for the Suction Pressure parameters and monitor: 0: No Dec (XXXXXX) 1: 1 Dec (XXXX.X) 2: 2 Dec (XXX.XX) 3: 3 Dec (XX.XXX)	Default: 1 Range: 0 to 3	–
Q5-25 (0F3B)	Suction Pressure Control Activation Level	SucPress Act Lvl	When the suction pressure drops below this level for more than the Q5-26 time, Suction Pressure Control is activated allowing it to affect the output frequency. When the suction pressure rises above this level for more than the Q5-26 time, Suction Pressure is deactivated causing it to have no effect on the output frequency. Suction Pressure Control is always active (if enabled) when set to 0.	Default: 10.0 PSI Range: 0.0 to 1200.0 <1>	–
Q5-26 (0F3C)	Suction Pressure Control Activation/Deactivation Delay	SucPress Act Dly	When the suction pressure drops below the Q5-25 level for more than this time, Suction Pressure Control is activated allowing it to affect the output frequency. When the suction pressure rises above the Q5-25 level for more than this time, Suction Pressure Control is deactivated causing it to have no effect on the output frequency.	Default: 2 s Range: 0 to 3600	–

<1> Units are determined by Q5-01, Suction Pressure Select, setting.

<2> Units are determined by Q5-18, Suction Pressure Detection Time Unit, setting.

◆ Q6: PI Auxiliary Control

No. (Addr. Hex)	Name	LCD Display	Description	Values	Page
Q6-01 (0F50)	PI Auxiliary Control Selection	PI Aux Ctrl Sel 0: Disabled 1: Enabled	Sets the mode of operation for the PI Auxiliary Control function. 0: Disabled 1: Enabled	Default: 0 Range: 0, 1	–
Q6-02 (0F51) RUN	PI Auxiliary Control Feedback Scale	PI Aux Lvl Scale	Sets the full scale (10 V or 20 mA) output of the pressure transducer connected to the analog input terminal programmed for “PI Aux FB Level” (H3-□□ = 27).	Default: 145.0 PSI <1> Min.: 1.0 Max.: 6000.0	–
Q6-03 (0F52) RUN	PI Auxiliary Control Setpoint	PI Aux Setpoint	Sets the level to which the drive will attempt to regulate.	Default: 20.0 PSI <1> Min.: 0.0 Max.: 6000.0	–
Q6-04 (0F53) RUN	PI Auxiliary Control Minimum Level	PI Aux Min Lvl	Sets the level below which the drive must fall for longer than the time set in Q6-05 time before the drive goes to sleep and turns off all lag pumps. Note: This feature is disabled when set to 0.0.	Default: 10.0 PSI <1> Min.: 0.0 Max.: 6000.0	–
Q6-05 (0F54) RUN	PI Auxiliary Control Sleep Delay Time	Sleep Dly Time	Inverse Acting (Q6-23 = 1): Sets the amount of time that the drive will delay before going to sleep after the level drops below Q6-04 setting. Normal Acting (Q6-23 = 0): Sets the amount of time that the drive will delay before going to sleep after the level rises above Q6-24 setting Range: 0 to 3600 s Default 5 s	Default: 5 s Min.: 0 Max.: 3600	–
Q6-06 (0F55) RUN	PI Auxiliary Control Wake-up Level	Wake-Up Level	This parameter is applicable when the drive has been forced to sleep based on the setting of Q6-04 or Q6-24 (PI Auxiliary Control Minimum Level or PI Auxiliary Control Maximum Level). Inverse Acting (Q6-23 = 1): The PI Aux Feedback must rise above the level set in this parameter for longer than the time set in Q6-07 to wake up. Normal Acting (Q6-23 = 0): The PI Aux Feedback must fall below this level for longer than the time set in Q6-07 to wake up.	Default: 30.0 PSI Min.: 0.0 Max.: 999.9 <3>	196

No. (Addr. Hex)	Name	LCD Display	Description	Values	Page
Q6-07 (0F56)	PI Auxiliary Control Wake-up Time	Wake-up Time	This parameter is applicable when the drive has been forced to sleep based on the setting of Q6-04 or Q6-24 (PI Auxiliary Control Minimum Level or PI Auxiliary Control Maximum Level). Inverse Acting (Q6-23 = 1): The PI Aux Feedback must rise above the level set in Q6-06 for longer than the time set in this parameter to wake up. Normal Acting (Q6-23 = 0): The PI Aux Feedback must fall below the level set in Q6-06 for longer than the time set in this parameter to wake up.	Default: 1 s Min.: 0 Max.: 3600	–
Q6-08 (0F57) RUN	PI Auxiliary Control Minimum Speed	PI Aux Min Spd	Sets the minimum speed at which the drive will be allowed to run when the PI Auxiliary Control is actively affecting the output speed. P1-06 and P4-12 (Minimum Pump Speed and Thrust Bearing Frequency) will be used as the minimum speed when PI Aux Control is not affecting the output speed or when this parameter is set to a value less than P1-06 and P4-12.	Default: 0.00 Hz Min.: 0.00 Max.: 400.00	–
Q6-09 (0F58) RUN	PI Auxiliary Control Low Level Detection	Low Level Detect	Sets the level below which the drive must fall for the longer than the time set in Q6-10 to respond depending on the Q6-11 setting. Setting this parameter to 0.0 disables this detection. Note: Q6-10 detection time delay only applies to Q6-11 settings 2 and 3 (Fault and Auto-Restart (time set by Q6-15)).	Default: 0.0 PSI Min.: 0.0 Max.: 999.9 <4>	–
Q6-10 (0F59) RUN	PI Auxiliary Control Low Level Detection Time	Low Lvl DetTime	Sets the amount of time for which the PI Aux Feedback must drop below the Q6-09 setting before the drive will react if Q6-11 = 2, 3.	Default: 0.1 min <2> Min.: 0.0 Max.: 300.0	–
Q6-11 (0F5A)	PI Auxiliary Control Low Level Detection Selection	Low Lvl Det Sel 0: No Display 1: Alarm Only 2: Fault 3: (Q6-15) Restart	Determines drive response when the level drops below the Q6-09 setting for longer than the time set in Q6-10. 0: No Display (Digital Output Only) 1: Alarm Only 2: Fault 3: Auto-Restart (time set by Q6-15) Note: Q6-10 detection time delay only applies to settings 2 and 3.	Default: 1 Range: 0 to 3	–
Q6-12 (0F5B) RUN	PI Auxiliary Control High Level Detection	Hi Level Detect	Sets the value above which the level must rise for longer than the time set in A6-13 to respond based on the Q6-14 setting. Setting this parameter to 0.0 disables this detection. Note: Q6-13 detection time delay only applies to Q6-14 settings 2 and 3.	Default: 0.0 PSI Min.: 0.0 Max.: 999.9 <5>	–
Q6-13 (0F5C) RUN	PI Auxiliary Control High Level Detection Time	Hi Lvl Det Time	Sets the length of time that the level must be above the Q6-12 setting before the drive will react when Q6-14 = 2, 3.	Default: 0.1 min <2> Min.: 0.0 Max.: 300.0	–
Q6-14 (0F5D)	PI Auxiliary Control High Level Detection Selection	High Lvl Det Sel 0: No Display 1: Alarm Only 2: Fault 3: (Q6-15) Restart	Determines drive response when the level rises above the Q6-12 setting for longer than the time set in Q6-13. 0: No Display 1: Alarm Only 2: Fault 3: Auto-Restart (time set by Q6-15) Note: Q6-10 detection time delay only applies to settings 2 and 3.	Default: 1 Range: 0 to 3	–
Q6-15 (0F5E)	PI Auxiliary Control Level Detection Restart Time	Level Restart Tm	Sets the length of time the drive will wait before attempting an auto-restart of the “Low PI Aux Lvl” or the “High PI Aux Lvl” fault. This parameter is effective only when Q6-11 = 3 or Q6-14 = 3, and L5-01 > 0.	Default: 5.0 min Min.: 0.1 Max.: 6000.0	–
Q6-16 (0F5F) RUN	PI Auxiliary Control P Gain	PI Aux P Gain	Sets the proportional gain for the suction pressure control.	Default: 2.00 Min.: 0.00 Max.: 25.00	–
Q6-17 (0F60) RUN	PI Auxiliary Control I Time	PI Aux I Time	Sets the integral time for the suction pressure control. A setting of zero disables the integrator.	Default: 5.0 s Min.: 0.0 Max.: 360.0	–

B.13 Q: PID Controller Parameters

No. (Addr. Hex)	Name	LCD Display	Description	Values	Page
Q6-18 (0F61)	PI Auxiliary Control Detection Time Unit	PI Aux Time Unit 0: Minutes (min) 1: Seconds (sec)	Sets the time unit for Q6-10 and Q6- 13. 0: Minutes (min) 1: Seconds (sec)	Default: 0 Range: 0, 1	–
Q6-19 (0F62)	PI Auxiliary Control Feedback Wirebreak	PI Aux WireBreak 0: No Display 1: Alarm Only 2: Fault	Sets the behavior of the analog input selected for PI Aux Feedback when it is programmed to receive a 4 to 20 mA signal and the signal is lost. 0: Disabled 1: Alarm Only 2: Fault (no retry, coast to stop)	Default: 2 Range: 0 to 2	–
Q6-20 (0F63)	PI Auxiliary Control Main PI Control	PI Aux Spd Cntrl 0: Disabled 1: Enabled	Selects whether the PI Auxiliary Controller has an effect on output speed. 0: Disabled 1: Enabled	Default: 1 Range: 0, 1	–
Q6-21 (0F64)	PI Auxiliary Control Level Unit Selection	PI Aux Lvl Unit 0: No Unit 1: PSI :lb/SqrInch 2: Pa:Pascals 3: Bar:Bar 4: "WC:InchOfWater 5: "Hg:Inch Mercury 6: ft: feet 7: m: meters 8: °F:DegFahrenheit 9: °C:DegCelsius 10: %: Percent 11: kPA: kilopascal 26: Custom (Q6-32~34)	Set the unit displayed for the PI Aux Level parameters and monitor. 0: No unit 1: PSI: Pounds per square inch 2: Pa: Pascals 3: Bar: Bar 4: "WC: Inch of water 5: "Hg: Inch of Mercury 6: ft: feet 7: m: meters 8: °F: Degrees Fahrenheit 9: °C: Degrees Celsius 10: Percent 11: kPA: kilopascal 26: Custom (Q6-32 to Q6-34)	Default: 1 Range: 0 to 11; 26	–
Q6-22 (0F65)	PI Auxiliary Control Level Decimal Place Position	PI Aux LvlDecPt 0: No Dec (XXXXX) 1: 1 Dec (XXXX.X) 2: 2 Dec (XXX.XX) 3: 3 Dec (XX.XXX)	Sets the number of decimal places for the PI Aux Level parameters and monitor. 0: No Dec (XXXXX) 1: 1 Dec (XXXX.X) 2: 2 Dec (XXX.XX) 3: 3 Dec (XX.XXX)	Default: 1 Range: 0 to 3	–
Q6-23 (0F66)	PI Auxiliary Control Output Level Selection	PI Aux OutLvlSel 0: Direct Acting 1: Inverse Acting	Determines whether the PI Auxiliary Controller is Direct-acting (feedback higher than setpoint results in lower speed) or Inverse-acting (feedback lower than setpoint results in lower speed). 0: Direct Acting 1: Inverse Acting	Default: 1 Range: 0, 1	196
Q6-24 (0F67) RUN	PI Auxiliary Control Maximum Level	PI Aux Max Lvl	Sets the value above which the level must rise for longer than the time set in Q6-05 for the drive to go to sleep and turn off all lag pumps. This feature is disabled when set to 0.	Default: 0.0 PSI </> Min.: 0.0 Max.: 6000.0	–
Q6-25 (0F68)	PI Auxiliary Control Activation Level	PI Aux Act Lvl	For Inverse Acting (Q6-23 = 1): When the PI Aux Feedback drops below this level for more than the Q6-26 time, PI Aux Control is activated allowing it to affect the output frequency. When the PI Aux Feedback rises above this level for more than the Q6-26 time, PI Aux Control is deactivated causing it to have no effect on the output frequency. For Normal Acting (Q6-23 = 0): When the PI Aux Feedback rises above this level for more than the Q6-26 time, PI Aux Control is activated allowing it to affect the output frequency. When the PI Aux Feedback drops below this level for more than the Q6-26 time, PI Aux Control is deactivated causing it to have no effect on the output frequency. PI Auxiliary Control is always active (if enabled) when set to 0.	Default: 0.0 PSI Range: 0.0 to 6000.0 </>	–

No. (Addr. Hex)	Name	LCD Display	Description	Values	Page
Q6-26 (0F69)	PI Auxiliary Control Activation/ Deactivation Delay	PI Aux Act Dly	For Inverse Acting (Q6-23 = 1): When the PI Aux Feedback drops below the Q6-25 level for more than this time, PI Aux Control is activated allowing it to affect the output frequency. When the PI Aux Feedback rises above the Q6-25 level for more than this time, PI Aux Control is deactivated causing it to have no effect on the output frequency. For Normal Acting (Q6-23 = 0): When the PI Aux Feedback rises above the Q6-25 level for more than this time, PI Aux Control is activated allowing it to affect the output frequency. When the PI Aux Feedback drops below the Q6-25 level for more than this time, PI Aux Control is deactivated causing it to have no effect on the output frequency.	Default: 2 s Range: 0 to 3600 s	–
Q6-32 (0F6F)	PI Aux Units Custom 1 st Character	PIAuxUnitCustom1	Sets the first character of the PI Aux custom unit display when Q6-21 = 26.	Default: 41 Range: 20 to 7A	–
Q6-33 (0F70)	PI Aux Units Custom 2 nd Character	PIAuxUnitCustom2	Sets the second character of the PI Aux custom unit display when Q6-21 = 26.	Default: 41 Range: 20 to 7A	–
Q6-34 (0F71)	PI Aux Units Custom 3 rd Character	PIAuxUnitCustom3	Sets the third character of the PI Aux custom unit display when Q6-21 = 26.	Default: 41 Range: 20 to 7A	–

- <1> Units depend on Q6-21, PI Auxiliary Control Level Unit Selection. Resolution depends on Q6-22, PI Auxiliary Control Level Decimal Place Position.
- <2> Unit is dependent on Q6-18, PI Auxiliary Control Detection Time Unit.
- <3> Range is 0.0 to 999.9 with sign-bit “-” or “+” indicating Delta to Setpoint (Q6-03).
- <4> Range is 0.0 to 999.9 with sign-bit “-” indicating Delta to Setpoint (Q6-03).
- <5> Range is 0.0 to 999.9 with sign-bit “+” indicating Delta to Setpoint (Q6-03).

B.14 S: Special Application

◆ S1: Dynamic Noise Control Function

No. (Addr. Hex)	Name	LCD Display	Description	Values	Page
S1-01 (3200)	Dynamic Audible Noise Control Function Selection	Dyn Noise Ctrl 0: Disabled 1: Enabled	0: Disabled 1: Enabled	Default: 0 Range: 0, 1	–
S1-02 (3201)	Voltage Reduction Rate	Volt Reduce Amt	Sets the rate at which the output voltage will be reduced as a percentage of the V/f pattern when operating with no load.	Default: 50.0% Min.: 50.0 Max.: 100.0	–
S1-03 (3202)	Voltage Restoration Level	V Reduce On Lvl	Sets the level when the drive should start restoring the voltage as a percentage of the drive rated torque.	Default: 20.0% Min.: 0.0 Max.: 90.0	–
S1-04 (3203)	Voltage Restoration Complete Level	V Reduce Off Lvl	Sets the level at which voltage restoration for the V/f pattern is complete as a percentage of the drive rated torque. If the output torque rises above the value of S1-04, then the voltage will be controlled in a manner specified by the V/f pattern setting.	Default: 50.0% Min.: S1-03 + 10.0 Max.: 100.0	–
S1-05 (3204)	Voltage Restoration Sensitivity Time Constant	Sensitivity Time	Sets the level of sensitivity of the output torque and LPF time constants for the voltage reduction rate. The level of sensitivity can be adjusted in accordance with the load response.	Default: 1.000 s Min.: 0.000 Max.: 3.000	–
S1-06 (3205)	Voltage Restoration Time Constant at Impact	Impact Load Time	Sets the voltage restoration time constant if an impact load is added.	Default: 0.050 s Min.: 0.000 Max.: 1.000	–

◆ S2: Programmable Run Timers

No. (Addr. Hex)	Name	LCD Display	Description	Values	Page
S2-01 (3206)	Sequence Timer 1 Start Time	Tmr 1 Start Time	Sets the start time for timer 1.	Default: 12:00AM <f> Min.: 12:00AM Max.: 11:59PM <f>	–
S2-02 (3207)	Sequence Timer 1 Stop Time	Tmr 1 Stop Time	Sets the stop time for timer 1.	Default: 12:00AM <f> Min.: 12:00AM Max.: 11:59PM <f>	–
S2-03 (3208)	Sequence Timer 1 Day Selection	Tmr 1 Day Sel 0: Timer disabled 1: Daily 2: Mon - Fri 3: Sat - Sun 4: Monday 5: Tuesday 6: Wednesday 7: Thursday 8: Friday 9: Saturday 10: Sunday	Sets the days for which sequence timer 1 is active. 0: Timer disabled 1: Daily 2: Mon - Fri 3: Sat - Sun 4: Monday 5: Tuesday 6: Wednesday 7: Thursday 8: Friday 9: Saturday 10: Sunday	Default: 0 Range: 0 to 10	–
S2-04 (3209)	Sequence Timer 1 Selection	Tmr 1 Seq Sel 0: Digital Out Only 1: Run 2: Run - PI Disable 3: Allow Alternation	Sets the action that occurs when sequence timers 1 is active. 0: Digital output only 1: Run 2: Run - PI disable 3: Allow Alternation	Default: 0 Range: 0 to 3	198

No. (Addr. Hex)	Name	LCD Display	Description	Values	Page
S2-05 (320A)	Sequence Timer 1 Reference Source	Tmr 1 Ref Source 0: Operator (d1-01/Q1-01) 0: Operator (d1-02/Q1-02) 0: Operator (d1-03/Q1-03) 0: Operator (d1-04/Q1-04) 4: Terminals 5: Serial com 6: Option PCB 7: Pulse Input 8: Set by b1-01	Selects the frequency reference source used for running the drive when sequence timer 1 is active (only applicable when S2-04 is set to 1 or 2). 0: Operator (d1-01/Q1-01) 1: Operator (d1-02/Q1-02) 2: Operator (d1-03/Q1-03) 3: Operator (d1-04/Q1-04) 4: Terminals 5: Serial communication 6: Option card 7: Pulse input 8: Set by b1-01	Default: 8 Range: 0 to 8	-
S2-06 (320B)	Sequence Timer 2 Start Time	Tmr 2 Start Time	Sets the start time for timer 2.	Default: 12:00AM </> Min.: 12:00AM Max.: 11:59PM </>	-
S2-07 (320C)	Sequence Timer 2 Stop Time	Tmr 2 Stop Time	Sets the stop time for timer 2.	Default: 12:00AM </> Min.: 12:00AM Max.: 11:59PM </>	-
S2-08 (320D)	Sequence Timer 2 Day Selection	Tmr 2 Day Sel 0: Timer Disabled 1: Daily 2: Mon - Fri 3: Sat - Sun 4: Monday 5: Tuesday 6: Wednesday 7: Thursday 8: Friday 9: Saturday 10: Sunday	Sets the days for which sequence timer 2 is active. 0: Timer disabled 1: Daily 2: Mon - Fri 3: Sat - Sun 4: Monday 5: Tuesday 6: Wednesday 7: Thursday 8: Friday 9: Saturday 10: Sunday	Default: 0 Range: 0 to 10	-
S2-09 (320E)	Sequence Timer 2 Selection	Tmr 2 Seq Sel 0: Digital Out Only 1: Run 2: Run - PI Disable 3: AllowAlternation	Sets the action that occurs when sequence timer 2 is active. 0: Digital output only 1: Run 2: Run - PI disable 3: Allow Alternation	Default: 0 Range: 0 to 3	198
S2-10 (320F)	Sequence Timer 2 Reference Source	Tmr 2 Ref Source 0: Operator (d1-01) 1: Operator (d1-02) 2: Operator (d1-03) 3: Operator (d1-04) 4: Terminals 5: Serial Com 6: Option PCB 7: Pulse Input 8: Set by b1-01	Selects the frequency reference source used for running the drive when sequence timer 2 is active (only applicable when S2-09 is set to 1 or 2). 0: Operator (d1-01/Q1-01) 1: Operator (d1-02/Q1-02) 2: Operator (d1-03/Q1-03) 3: Operator (d1-04/Q1-04) 4: Terminals 5: Serial communication 6: Option card 7: Pulse input 8: Set by b1-01	Default: 8 Range: 0 to 8	-
S2-11 (3210)	Sequence Timer 3 Start Time	Tmr 3 Start Time	Sets the start time for timer 3.	Default: 12:00AM </> Min.: 12:00AM Max.: 11:59PM </>	-
S2-12 (3211)	Sequence Timer 3 Stop Time	Tmr 3 Stop Time	Sets the stop time for timer 3.	Default: 12:00AM </> Min.: 12:00AM Max.: 11:59PM </>	-

B.14 S: Special Application

No. (Addr. Hex)	Name	LCD Display	Description	Values	Page
S2-13 (3212)	Sequence Timer 3 Day Selection	Tmr 3 Day Sel 0: Timer Disabled 1: Daily 2: Mon - Fri 3: Sat - Sun 4: Monday 5: Tuesday 6: Wednesday 7: Thursday 8: Friday 9: Saturday 10: Sunday	Sets the days for which sequence timer 3 is active. 0: Timer disabled 1: Daily 2: Mon - Fri 3: Sat - Sun 4: Monday 5: Tuesday 6: Wednesday 7: Thursday 8: Friday 9: Saturday 10: Sunday	Default: 0 Range: 0 to 10	–
S2-14 (3213)	Sequence Timer 3 Selection	Tmr 3 Seq Sel 0: Digital out only 1: Run 2: Run - PI Disable 3: AllowAlternation	Sets the action that occurs when sequence timer 3 is active. 0: Digital output only 1: Run 2: Run - PI disable 3: Allow Alternation	Default: 0 Range: 0 to 3	198
S2-15 (3214)	Sequence Timer 3 Reference Source	Tmr 3 Ref Source 0: Opr (dx-0x/Qx-0x) 1: Opr (dx-0x/Qx-0x) 2: Opr (dx-0x/Qx-0x) 3: Opr (dx-0x/Qx-0x) 4: Terminals 5: Serial Com 6: Option PCB 7: Pulse Input 8: Set by b1-01	Selects the frequency reference source used for running the drive when sequence timer 3 is active (only applicable when S2-14 is set to 1 or 2). 0: Operator (d1-01/Q1-01) 1: Operator (d1-02/Q1-02) 2: Operator (d1-03/Q1-03) 3: Operator (d1-04/Q1-04) 4: Terminals 5: Serial communication 6: Option card 7: Pulse input 8: Set by b1-01	Default: 8 Range: 0 to 8	–
S2-16 (3215)	Sequence Timer 4 Start Time	Tmr 4 Start Time	Sets the start time for timer 4.	Default: 12:00AM <?> Min.: 12:00AM Max.: 11:59PM <?>	–
S2-17 (3216)	Sequence Timer 4 Stop Time	Tmr 4 Stop Time	Sets the stop time for timer 4. The value must be set greater than or equal to S2-16.	Default: 12:00AM <?> Min.: 12:00AM Max.: 11:59PM <?>	–
S2-18 (3217)	Sequence Timer 4 Day Selection	Tmr 4 Day Sel 0: Timer Disabled 1: Daily 2: Mon - Fri 3: Sat - Sun 4: Monday 5: Tuesday 6: Wednesday 7: Thursday 8: Friday 9: Saturday 10: Sunday	Sets the days for which sequence timer 4 is active. 0: Timer disabled 1: Daily 2: Mon - Fri 3: Sat - Sun 4: Monday 5: Tuesday 6: Wednesday 7: Thursday 8: Friday 9: Saturday 10: Sunday	Default: 0 Range: 0 to 10	–
S2-19 (3218)	Sequence Timer 4 Selection	Tmr 4 Seq Sel 0: Digital Out Only 1: Run 2: Run - PI Disable 3: AllowAlternation	Sets the action that occurs when sequence timer 4 is active. 0: Digital output only 1: Run 2: Run - PI disable 3: Allow Alternation	Default: 0 Range: 0 to 3	198
S2-20 (3219)	Sequence Timer 4 Reference Source	Tmr 4 Ref Source 0: Opr (dx-0x/Qx-0x) 1: Opr (dx-0x/Qx-0x) 2: Opr (dx-0x/Qx-0x) 3: Opr (dx-0x/Qx-0x) 4: Terminals 5: Serial Com 6: Option PCB 7: Pulse Input 8: Set by b1-01	Selects the frequency reference source used for running the drive when sequence timer 4 is active (only applicable when S2-19 is set to 1 or 2). 0: Operator (d1-01/Q1-01) 1: Operator (d1-02/Q1-02) 2: Operator (d1-03/Q1-03) 3: Operator (d1-04/Q1-04) 4: Terminals 5: Serial communication 6: Option card 7: Pulse input 8: Set by b1-01	Default: 8 Range: 0 to 8	–

- <1> Default is 12:00AM when o4-20 = 0 (12-hour). Default is 00:00 when o4-20 = 1 (24-hour).
- <2> Range is 12:00AM ~ 11:59PM when o4-20 = 0 (12-hour), and the range display will show: “(12:00A~11:59PM)”. Range is 00:00 ~ 24:00 when o4-20 = 1 (24-hour).

◆ S6: Protection

No. (Addr. Hex)	Name	LCD Display	Description	Values	Page
S6-07 (323C)	Output Phase Loss Level for Dynamic Noise Control	DNC Outp Ph Loss	Reduces the output phase loss level when Dynamic Noise Control is active.	Default: 100.0% Min.: 10.0 Max.: 100.0	–

B.15 T: Motor Tuning

Enter data into the following parameters to tune the motor and drive for optimal performance.

◆ T1: Induction Motor Auto-Tuning

No. (Addr. Hex)	Name	LCD Display	Description	Values	Page
T1-01 (0701) <1>	Auto-Tuning Mode Selection	Tuning Mode Sel 0: Standard Tuning 2: Term Resistance 3: V/f Engy Sav Tun 4: Tune-No Rotate2 5: Tune-No Rotate3	0: Rotational Auto-Tuning 2: Stationary Auto-Tuning for Line-to-Line Resistance 3: Rotational Auto-Tuning for V/f Control (necessary for Energy Savings and Speed Estimation Speed Search) 4: Stationary Auto-Tuning 2 5: Stationary Auto-Tuning 3	Default: 0 <2> Range: 0; 2 to 5	–
T1-02 (0702)	Motor Rated Power	Mtr Rated Power	Sets the motor rated power as specified on the motor nameplate. Note: Use the following formula to convert horsepower into kilowatts: 1HP = 0.746 kW.	Default: <3> Min.: 0.00 kW Max.: 650.00 kW	–
T1-03 (0703)	Motor Rated Voltage	Rated Voltage	Sets the motor rated voltage as specified on the motor nameplate.	Default: 200.0 V <4> Min: 0.0 Max: 255.0 <4>	–
T1-04 (0704)	Motor Rated Current	Rated Current	Sets the motor rated current as specified on the motor nameplate.	Default: <3> Min.: 10% of drive rated current Max.: 150% of drive rated current	–
T1-05 (0705)	Motor Base Frequency	Rated Frequency	Sets the rated frequency of the motor as specified on the motor nameplate.	Default: 60.0 Hz Min.: 0.0 Max.: 400.0	–
T1-06 (0706)	Number of Motor Poles	Number of Poles	Sets the number of motor poles as specified on the motor nameplate.	Default: 4 Min.: 2 Max.: 48	–
T1-07 (0707)	Motor Base Speed	Rated Speed	Sets the rated speed of the motor as specified on the motor nameplate.	Default: 1750 r/min Min.: 0 Max.: 24000	–
T1-09 (0709)	Motor No-Load Current (Stationary Auto-Tuning)	No-Load Current	OLV Sets the no-load current for the motor. After setting the motor capacity to T1-02 and the motor rated current to T1-04, this parameter will automatically display the no-load current for a standard 4-pole Yaskawa motor. Enter the no-load current as indicated on the motor test report.	Default: – Min.: 0 A Max.: T1-04 <5>	–
T1-10 (070A)	Motor Rated Slip (Stationary Auto-Tuning)	Motor Rated Slip	OLV Sets the motor rated slip. After setting the motor capacity to T1-02, this parameter will automatically display the motor slip for a standard 4-pole Yaskawa motor. Enter the motor slip as indicated on the motor test report.	Default: – Min.: 0.00 Hz Max.: 20.00 Hz	–
T1-11 (070B)	Motor Iron Loss	Mtr Iron Loss(W)	Sets the iron loss for determining the Energy Saving coefficient. The value is set to E2-10 (motor iron loss) set when the power is cycled. If T1-02 is changed, a default value appropriate for the motor capacity that was entered will appear.	Default: 14 W <6> Min.: 0 Max.: 65535	–

<1> The availability of certain Auto-Tuning methods is determined by the control mode selected for the drive.

<2> Default setting is determined by parameter A1-02, Control Method Setting.

<3> Default setting is determined by parameter o2-04, Drive Model Selection.

<4> Values shown are specific to 200 V class drives. Double the value for 400 V class drives.

<5> Display is in the following units:

2□0028, 2□0042, and 4□0011 to 4□0027: 0.01 A units

2□0054 to 2□0248 and 4□0034 to 4□0930: 0.1 A units

<6> Default setting value differs depending on the motor code value and motor parameter settings.

B.16 U: Monitors

Monitor parameters allow the user to view drive status, fault information, and other data concerning drive operation.

◆ U1: Operation Status Monitors

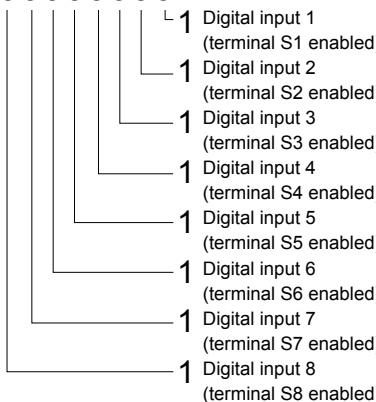
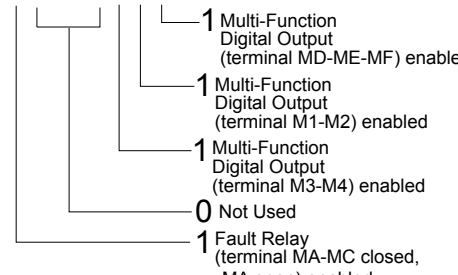
No. (Addr. Hex)	Name	LCD Display	Description	Analog Output Level	Unit
U1-01 (0040)	Frequency Reference	Frequency Ref	Monitors the frequency reference. Display units are determined by o1-03.	10 V: Max. frequency (-10 to +10 V)	0.01 Hz
U1-02 (0041)	Output Frequency	Output Freq	Displays the output frequency. Display units are determined by o1-03.	10 V: Max. frequency (-10 to +10 V)	0.01 Hz
U1-03 (0042)	Output Current	Output Current	Displays the output current.	10 V: Drive rated current	<1> <2>
U1-04 (0043)	Control Method	Control Method	0: V/f Control 2: Open Loop Vector Control	No signal output available	-
U1-05 (0044)	Motor Speed	Motor Speed	OLV Displays the motor speed feedback. Display units are determined by o1-03.	10 V: Max. frequency (-10 to +10 V)	0.01 Hz
U1-06 (0045)	Output Voltage Reference	Output Voltage	Displays the output voltage.	10 V: 200 Vrms <3>	0.1 Vac
U1-07 (0046)	Control Circuit Voltage	DC Bus Voltage	Displays the control circuit voltage.	10 V: 400 V <3>	1 Vdc
U1-08 (0047)	Output Power	Output kWatts	Displays the output power (this value is calculated internally).	10 V: <4> (-10 to +10 V)	<5>
U1-09 (0048)	Torque Reference	Torque Reference	OLV Monitors the internal torque reference.	10 V: Motor rated torque (-10 to +10 V)	0.1%
U1-10 (0049)	Input Terminal Status	Input Term Sts	Displays the input terminal status. U1 - 10 = 00000000  <ul style="list-style-type: none"> 1 Digital input 1 (terminal S1 enabled) 1 Digital input 2 (terminal S2 enabled) 1 Digital input 3 (terminal S3 enabled) 1 Digital input 4 (terminal S4 enabled) 1 Digital input 5 (terminal S5 enabled) 1 Digital input 6 (terminal S6 enabled) 1 Digital input 7 (terminal S7 enabled) 1 Digital input 8 (terminal S8 enabled) 	No signal output available	-
U1-11 (004A)	Output Terminal Status	Output Term Sts	Displays the output terminal status. U1 - 11 = 00000000  <ul style="list-style-type: none"> 1 Multi-Function Digital Output (terminal MD-ME-MF) enabled 1 Multi-Function Digital Output (terminal M1-M2) enabled 1 Multi-Function Digital Output (terminal M3-M4) enabled 0 Not Used 1 Fault Relay (terminal MA-MC closed, MA open) enabled 	No signal output available	-

B.16 U: Monitors

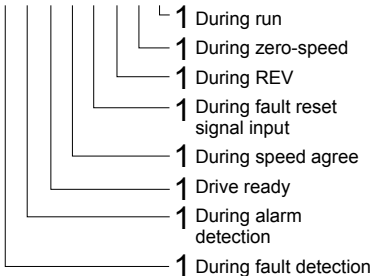
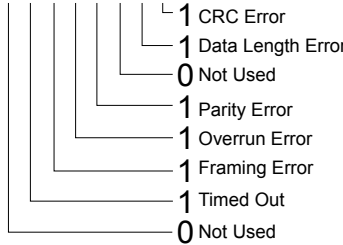
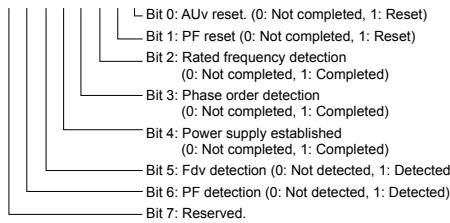
No. (Addr. Hex)	Name	LCD Display	Description	Analog Output Level	Unit
U1-12 (004B)	Drive Status	Int Ctl Sts 1	Displays the drive operation status. U1 - 12=00000000 	No signal output available	–
U1-13 (004E)	Terminal A1 Input Level	Term A1 Level	Displays the signal level to analog input terminal A1.	10 V: 100% (-10 to +10 V)	0.1%
U1-14 (004F)	Terminal A2 Input Level	Term A2 Level	Displays the signal level to analog input terminal A2.	10 V: 100% (-10 to +10 V)	0.1%
U1-15 (0050)	Terminal A3 Input Level	Term A3 Level	Displays the signal level to analog input terminal A3.	10 V: 100% (-10 to +10 V)	0.1%
U1-16 (0053)	Output Frequency after Soft Starter	SFS Output	Displays output frequency with ramp time and S-curves. Units determined by o1-03.	10 V: Max. frequency (-10 to +10 V)	0.01 Hz
U1-18 (0061)	oPE Fault Parameter	OPE Error Code	Displays the parameter number that caused the oPE02 or oPE08 operation error.	No signal output available	–
U1-19 (0066)	MEMOBUS/Modbus Error Code	Transmit Err	Displays the contents of a MEMOBUS/Modbus error. U1 - 19=00000000 	No signal output available	–
U1-24 (007D)	Input Pulse Monitor	Term RP Inp Freq	Displays the frequency to pulse train input terminal RP.	Determined by H6-02	1 Hz
U1-25 (004D)	Software Number (Flash)	CPU 1 SW Number	FLASH ID	No signal output available	–
U1-26 (005B)	Software No. (ROM)	CPU 2 SW Number	ROM ID	No signal output available	–
U1-54 (1083)	Drive Input Power Voltage Effective Value	Power Supply Volt	Displays the effective value of the drive input power voltage.	200 V class 10 V: 400 V 400 V class 10 V: 800 V	1 V
U1-58 (1087)	Power Supply Frequency	Power Supply Freq	Displays the frequency of the drive input power supply.	10 V: Rated frequency	0.1 Hz
U1-72 (1095)	Input Power Supply Information	Power Supply Sts	Displays information on the input power supply. U1 - 72=00000000 	No signal output available	–
U1-75 (0851)	Time-Hour/Minute	Time Hr Min HHMM	Displays the current time (Hours and Minutes).	No signal output available	–

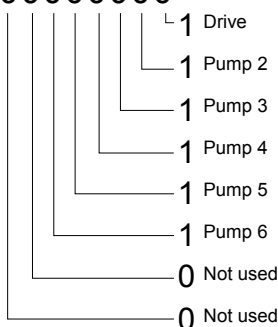
No. (Addr. Hex)	Name	LCD Display	Description	Analog Output Level	Unit
U1-76 (0852)	Date – Year	Date Year	Displays the current year.	No signal output available	–
U1-77 (0853)	Date – Month/Day	Date Mo Day MMDD	Displays the current date (Month and Date).	No signal output available	–
U1-78 (0854)	Date – Week Day	Date Week	Displays the current day of the week. 0: Sunday 1: Monday 2: Tuesday 3: Wednesday 4: Thursday 5: Friday 6: Saturday	No signal output available	–
U1-79 (0B9A)	PI Feedback Back-up	PI Fdbk Backup	Displays the PI Feedback Back-up signal (H3-□□ = 24) used when the primary PI Feedback (H3-□□ = B) is lost.	No signal output available	Dep. on P1-02
U1-81 (0B9C)	Differential PI Feedback	Diff PI Feedback	Differential Feedback signal (H3-□□ = 28).	No signal output available	Dep. on P1-02
U1-82 (0B9D)	Two Motor Time to Alternate	2Motor Alt Time	Time remaining before making a motor switch.	No signal output available	min
U1-83 (0B9E)	Flow Rate	Flow Rate	Displays the flow rate based on the pulse input frequency or the analog voltage (flow rate input) and parameters P6-01 and P6-04. A 2-second first order filter will be applied to this monitor.	Full scale: P6-01	Dep. on P6-04 and P6-22
U1-84 (0B9F)	Accumulation Level - Millions	Volume * 1000000	Displays the recorded volume from the flow meter (pulse input or analog voltage). Total volume is calculated as follows: Total Volume = (U1-84 * 1000000) + (U1-85 * 1000) + U1-86 + U1-87	No signal output available	Dep. on P6-16
U1-85 (0BA0)	Accumulation Level - Thousands	Volume * 1000			
U1-86 (0BA1)	Accumulation Level - Ones	Volume * 1			
U1-87 (0BA2)	Accumulation Level - Decimal	Volume * 0.0001			
U1-88 (N/A)	Total Volume Accumulated	Total Vol (gal) or Total Vol (A-F)	Displays the total volume.	Full scale: N/A	Dep. on P6-16
U1-89 (N/A)	Delta Volume Accumulated	Delta Vol (gal) or Total Vol (A-F)	Displays the delta volume: Total Volume (U1-88/U1-84 to U1-87) - Starting Delta Volume (P6-36 to P6-39).	Full scale: N/A	Dep. on P6-16
U1-90 (0BA5)	Pump Setpoint	Pump Setpoint	Displays the PID Setpoint.	No signal output available	Dep. on P1-02
U1-91 (0BA6) <7>	Pump Feedback	Pump Feedback	Displays the PID Feedback.	No signal output available	Dep. on P1-02
U1-92 (0BA7)	Pump Status	Pump Status	Displays Pump Running Status. U1 - 92=00000000 	No signal output available	–
U1-93 (0BA8)	Total Setpoint Compensation	Total SP Comp.	Displays the total absolute Setpoint Compensation.	No signal output available	Dep. on P1-02
U1-94 (0BA9)	Motor Speed	Motor Speed	Displays the absolute value of the output frequency (U1-02) converted to RPM.	No signal output available	1 RPM

B.16 U: Monitors

No. (Addr. Hex)	Name	LCD Display	Description	Analog Output Level	Unit
U1-96 (0BAB)	PI Auxiliary Control Feedback Level	PI Aux FB Level	Displays the PI Auxiliary Control Feedback Level (H3-□□ = 27).	N/A	Unit dep. on Q6-21 Res. dep. on Q6-22
U1-97 (0BAC)	Water Level	Water Level	Displays the amount of water above the water level sensor.	Full scale: 10 V = Q4-02	0.1 ft.
U1-98 (0BAD)	Suction Pressure	Suction Pressure	Displays the amount of suction pressure.	Full scale: 10 V = Q5-02	0.1 PSI or "Hg
U1-99 (0BAE) <?>	Anti-No-Flow Timer	ANF Timer	The Anti-No-Flow reduces the output frequency when this value reaches the P2-24 setting.	No signal output available	0.1 s

<1> Display is in the following units:

2□0028, 2□0042, and 4□0011 to 4□0027: 0.01 A units

2□0054 to 2□0248 and 4□0034 to 4□0720: 0.1 A units

4□0930: 1 A units

<2> The values of U1-03, U2-05, and U4-13 are displayed on the digital operator in units of amperes. When those monitors are checked using MEMOBUS/Modbus communications, the monitor values in MEMOBUS/Modbus communications are displayed as: numeric value / 8192 × drive rated current (A) from the condition “192 (maximum value) = drive rated current (A)”

<3> Values shown are specific to 200 V class drives. Double the value for 400 V class drives.

<4> In V/f control mode, 10 V = default value of E2-11. In OLV control mode, 10 V = setting value of E2-11 (kW).

<5> Display is in the following units:

2□0028, 2□0042, and 4□0011 to 4□0027: 0.01 kW units

2□0054 to 2□0248 and 4□0034 to 4□0930: 0.1 kW units

<7> Monitor is available through the Quick Monitor screen.

◆ U2: Fault Trace

No. (Addr. Hex)	Name	LCD Display	Description	Analog Output Level	Unit
U2-01 (0080)	Current Fault	Current Fault	Displays the current fault.	No signal output available	–
U2-02 (0081)	Previous Fault	Last Fault	Displays the previous fault.	No signal output available	–
U2-03 (0082)	Frequency Reference at Previous Fault	Frequency Ref	Displays the frequency reference at the previous fault.	No signal output available	0.01 Hz
U2-04 (0083)	Output Frequency at Previous Fault	Output Freq	Displays the output frequency at the previous fault.	No signal output available	0.01 Hz
U2-05 (0084)	Output Current at Previous Fault	Output Current	Displays the output current at the previous fault.	No signal output available	<?> <?>
U2-06 (0085)	Motor Speed at Previous Fault	Motor Speed	OLV Displays the motor speed at the previous fault.	No signal output available	0.01 Hz
U2-07 (0086)	Output Voltage at Previous Fault	Output Voltage	Displays the output voltage at the previous fault.	No signal output available	0.1 Vac
U2-08 (0087)	Control Circuit DC Voltage at Previous Fault	DC Bus Voltage	Displays the control circuit DC voltage at the previous fault.	No signal output available	1 Vdc
U2-09 (0088)	Output Power at Previous Fault	Output kWatts	Displays the output power at the previous fault.	No signal output available	0.1 kW
U2-10 (0089)	Torque Reference at Previous Fault	Torque Reference	OLV Displays the torque reference at the previous fault.	No signal output available	0.1%
U2-11 (008A)	Input Terminal Status at Previous Fault	Input Term Sts	Displays the input terminal status at the previous fault. Displayed as in U1-10.	No signal output available	–
U2-12 (008B)	Output Terminal Status at Previous Fault	Output Term Sts	Displays the output status at the previous fault. Displayed as in U1-11.	No signal output available	–

No. (Addr. Hex)	Name	LCD Display	Description	Analog Output Level	Unit
U2-13 (008C)	Drive Operation Status at Previous Fault	Inverter Status	Displays the operation status of the drive at the previous fault. Displayed as in U1-12.	No signal output available	–
U2-14 (008D)	Cumulative Operation Time at Previous Fault	Elapsed time	Displays the cumulative operation time at the previous fault.	No signal output available	1 h
U2-15 (07E0)	Run Speed after Soft Starter at Previous Fault	SFS Output	Displays the run speed after a soft start when a previous fault occurred. Displayed as in U1-16.	No signal output available	0.01 Hz
U2-16 (07E1)	Motor q-Axis Current at Previous Fault	Motor Iq Current	Displays the q-axis current for the motor at the previous fault. Displayed as in U6-01.	No signal output available	0.1%
U2-17 (07E2)	Motor d-Axis Current at Previous Fault	Motor Id Current	OLV Displays the d-axis current for the motor at the previous fault. Displayed as in U6-02.	No signal output available	0.1%
U2-20 (008E)	Heatsink Temperature at Previous Fault	Actual Fin Temp	Displays the temperature of the heatsink when the most recent fault occurred. Displayed as in U4-08.	No signal output available	1 °C
U2-30 (3008)	Date Year at Previous Fault	Date Year YYYY	Displays the year when the most recent fault occurred.	No signal output available	–
U2-31 (3009)	Date Month and Day at Previous Fault	Date Mo Day MMDD	Displays the date and day when the most recent fault occurred.	No signal output available	–
U2-32 (300A)	Time Hours and Minutes at Previous Fault	Time Hr Min HHMM	Displays the time when the most recent fault occurred.	No signal output available	–
U2-50 (085C)	Input Power Supply	Power Supply Sts	Displays the input power supply information at the previous fault. Displayed as in U1-72.	No signal output available	–
U2-54 (0843)	Power Supply Voltage at Previous Fault	PowerSupply Volt	Displays the power supply voltage at the previous fault. Displayed as in U1-54.	No signal output available	1 V
U2-58 (0847)	Power Supply Frequency at Previous Fault	PowerSupply Freq	Displays the power supply frequency at the previous fault. Displayed as in U1-58.	No signal output available	0.1 Hz
U2-90 (3044)	Pump Setpoint	Pump Setpoint	Displays the PID Setpoint at the time of fault.	Full scale: N/A	Dep. on P1-02
U2-91 (3045)	Pump Feedback	Pump Feedback	Displays the PID Feedback at the time of fault.	Full scale: N/A	Dep. on P1-02
U2-94 (3048)	Motor Speed	Motor Speed	Displays the absolute value of the output frequency (U1-02) converted to RPM at the time of fault.	Full scale: N/A	1 RPM
U2-97 (304B)	Water Level	Water Level	Displays the amount of water above the water level sensor at the time of fault.	Full scale: N/A	0.1 ft.
U2-98 (304C)	Suction Pressure	Suction Pressure	Displays the amount of suction pressure at the time of fault.	Full scale: N/A	0.1 PSI or “Hg

<1> Display is in the following units:

2□0028, 2□0042, and 4□0011 to 4□0027: 0.01 A units

2□0054 to 2□0248 and 4□0034 to 4□0720: 0.1 A units

4□0930: 1 A units

<2> The values of U1-03, U2-05, and U4-13 are displayed on the digital operator in units of amperes. When those monitors are checked using MEMOBUS/Modbus communications, the monitor values in MEMOBUS/Modbus communications are displayed as: numeric value / 8192 × drive rated current (A) from the condition “192 (maximum value) = drive rated current (A)”

Note: Note: Fault histories are not kept when CPF00, CPF01, CPF06, CPF24, oFA00, oFb00, oFC00, Uv1, Uv2, or Uv3 occur.

◆ U3: Fault History

No. (Addr. Hex)	Name	LCD Display	Description	Analog Output Level	Unit
U3-01 to U3-04 (0090 to 0093 (0800 to 0803))	1st to 4th Most Recent Fault	Fault Message □	Displays the first to the fourth most recent faults.	No signal output available	–
U3-05 to U3-10 (0804 to 0809)	5th to 10th Most Recent Fault	Fault Message □	Displays the fifth to the tenth most recent faults. After ten faults, data for the oldest fault is deleted. The most recent fault appears in U3-01, with the next most recent fault appearing in U3-02. The data is moved to the next monitor parameter each time a fault occurs.	No signal output available	–
U3-11 to U3-14 (0094 to 0097 (080A to 080D))	Cumulative Operation Time at 1st to 4th Most Recent Fault	Elapsed Time □	Displays the cumulative operation time when the first to the fourth most recent faults occurred.	No signal output available	1 h
U3-15 to U3-20 (080E to 0813)	Cumulative Operation Time at 5th to 10th Most Recent Fault	Elapsed Time □	Displays the cumulative operation time when the fifth to the tenth most recent faults occurred.	No signal output available	1 h
U3-21 (300B)	Date Year at Most Recent Fault	Fault 1 YYYY	Displays the year when the most recent fault occurred.	No signal output available	–
U3-22 (300C)	Date Month and Day at Most Recent Fault	Fault 1 MMDD	Displays the date and day when the most recent faults occurred.	No signal output available	–
U3-23 (300D)	Time Hours and Minutes at Most Recent Fault	Fault 1 HHMM	Displays the time when the most recent fault occurred.	No signal output available	–
U3-24 (300E)	Date Year at 2nd Most Recent Fault	Fault 2 YYYY	Displays the year when the second most recent fault occurred.	No signal output available	–
U3-25 (300F)	Date Month and Day at 2nd Most Recent Fault	Fault 2 MMDD	Displays the date and day when the second most recent fault occurred.	No signal output available	–
U3-26 (3010)	Time Hours and Minutes at 2nd Most Recent Fault	Fault 2 HHMM	Displays the time when the second most recent fault occurred.	No signal output available	–
U3-27 (3011)	Date Year at 3rd Most Recent Fault	Fault 3 YYYY	Displays the year when the most third recent fault occurred.	No signal output available	–
U3-28 (3012)	Date Month and Day at 3rd Most Recent Fault	Fault 3 MMDD	Displays the date and day when the third most recent fault occurred.	No signal output available	–
U3-29 (3013)	Time Hours and Minutes at 3rd Most Recent Fault	Fault 3 HHMM	Displays the time when the third most recent fault occurred.	No signal output available	–
U3-30 (3014)	Date Year at 4th Most Recent Fault	Fault 4 YYYY	Displays the year when the fourth most recent fault occurred.	No signal output available	–
U3-31 (3015)	Date Month and Day at 4th Most Recent Fault	Fault 4 MMDD	Displays the date and day when the fourth most recent fault occurred.	No signal output available	–
U3-32 (3016)	Time Hours and Minutes at 4th Most Recent Fault	Fault 4 HHMM	Displays the time when the fourth most recent fault occurred.	No signal output available	–
U3-33 (3017)	Date Year at 5th Most Recent Fault	Fault 5 YYYY	Displays the year when the fifth most recent fault occurred.	No signal output available	–
U3-34 (3018)	Date Month and Day at 5th Most Recent Fault	Fault 5 MMDD	Displays the date and day when the fifth most recent fault occurred.	No signal output available	–
U3-35 (3019)	Time Hours and Minutes at 5th Most Recent Fault	Fault 5 HHMM	Displays the time when the fifth most recent fault occurred.	No signal output available	–
U3-36 (301A)	Date Year at 6th Most Recent Fault	Fault 6 YYYY	Displays the year when the sixth most recent fault occurred.	No signal output available	–
U3-37 (301B)	Date Month and Day at 6th Most Recent Fault	Fault 6 MMDD	Displays the date and day when the sixth most recent fault occurred.	No signal output available	–
U3-38 (301C)	Time Hours and Minutes at 6th Most Recent Fault	Fault 6 HHMM	Displays the time when the sixth most recent fault occurred.	No signal output available	–
U3-39 (301D)	Date Year at 7th Most Recent Fault	Fault 7 YYYY	Displays the year when the seventh most recent fault occurred.	No signal output available	–

No. (Addr. Hex)	Name	LCD Display	Description	Analog Output Level	Unit
U3-40 (301E)	Date Month and Day at 7th Most Recent Fault	Fault 7 MMDD	Displays the date and day when the seventh most recent fault occurred.	No signal output available	–
U3-41 (301F)	Time Hours and Minutes at 7th Most Recent Fault	Fault 7 HHMM	Displays the time when the seventh most recent fault occurred.	No signal output available	–
U3-42 (3020)	Date Year at 8th Most Recent Fault	Fault 8 YYYY	Displays the year when the eighth most recent fault occurred.	No signal output available	–
U3-43 (3021)	Date Month and Day 8th at Most Recent Fault	Fault 8 MMDD	Displays the date and day when the eighth most recent fault occurred.	No signal output available	–
U3-44 (3022)	Time Hours and Minutes at 8th Most Recent Fault	Fault 8 HHMM	Displays the time when the eighth most recent fault occurred.	No signal output available	–
U3-45 (3023)	Date Year at 9th Most Recent Fault	Fault 9 YYYY	Displays the year when the ninth most recent fault occurred.	No signal output available	–
U3-46 (3024)	Date Month and Day at 9th Most Recent Fault	Fault 9 MMDD	Displays the date and day when the ninth most recent fault occurred.	No signal output available	–
U3-47 (3025)	Time Hours and Minutes at 9th Most Recent Fault	Fault 9 HHMM	Displays the time when the ninth most recent fault occurred.	No signal output available	–
U3-48 (3026)	Date Year at 10th Most Recent Fault	Fault 10 YYYY	Displays the year when the tenth most recent fault occurred.	No signal output available	–
U3-49 (3027)	Date Month and Day at 10th Most Recent Fault	Fault 10 MMDD	Displays the date and day when the tenth most recent fault occurred.	No signal output available	–
U3-50 (3028)	Time Hours and Minutes at 10th Most Recent	Fault 10 HHMM	Displays the time when the tenth most recent fault occurred.	No signal output available	–

Note: Note: Fault histories are not kept when CPF00, CPF01, CPF06, CPF24, oFA00, oFb00, oFC00, Uv1, Uv2, or Uv3 occur.

◆ U4: Maintenance Monitors

No. (Addr. Hex)	Name	LCD Display	Description	Analog Output Level	Unit
U4-01 (004C) <I>	Cumulative Operation Time	Drv Elapsed Time	Displays the cumulative operation time of the drive. The value for the cumulative operation time counter can be reset in parameter o4-01. Use parameter o4-02 to determine if the operation time should start as soon as the power is switched on or only while the Run command is present. The maximum number displayed is 99999, after which the value is reset to 0.	No signal output available	1 h
U4-02 (0075)	Number of Run Commands	RUN Cmd Counter	Displays the number of times the Run command is entered. Reset the number of Run commands using parameter o4-13. This value will reset to 0 and start counting again after reaching 65535.	No signal output available	1 Time
U4-03 (0067) <2>	Cooling Fan Operation Time	Fan Elapsed Time	Displays the cumulative operation time of the cooling fan. The default value for the fan operation time is reset in parameter o4-03. This value will reset to 0 and start counting again after reaching 99999.	No signal output available	1 h
U4-04 (007E)	Cooling Fan Maintenance	Fan Life Mon	Displays main cooling fan usage time as a percentage of its expected performance life. Parameter o4-03 can be used to reset this monitor. Replace the fan when this monitor reaches 90%.	No signal output available	1%
U4-05 (007C)	Capacitor Maintenance	Cap Life Mon	Displays control circuit capacitor usage time as a percentage of their expected performance life. Parameter o4-05 can be used to reset this monitor. Replace the capacitor when this monitor reaches 90%.	No signal output available	1%
U4-06 (07D6)	Soft Charge Bypass Relay Maintenance	ChgCirc Life Mon	Displays the soft charge bypass relay maintenance time as a percentage of its estimated performance life. Parameter o4-07 can be used to reset this monitor. Replace the soft charge bypass relay when this monitor reaches 90%.	No signal output available	1%
U4-08 (0068)	Heatsink Temperature	Heatsink Temp	Displays the heatsink temperature.	10 V: 100 °C	1 °C
U4-09 (005E)	LED Check	LED Oper Check	Lights all segments of the LED to verify that the display is working properly.	No signal output available	–

Parameter List

B

B.16 U: Monitors

No. (Addr. Hex)	Name	LCD Display	Description	Analog Output Level	Unit
U4-10 (005C)	kWh, Lower 4 Digits	kWh Lower 4 dig	Monitors the drive output power usage (or consumption). The value is shown as a 9-digit number displayed across two monitor parameters, U4-10 and U4-11. Example: 12345678.9 kWh is displayed as: U4-10: 678.9 kWh U4-11: 12345 MWh	No signal output available	0.1 kWh
U4-11 (005D)	kWh, Upper 5 Digits	kWh Upper 5 dig		No signal output available	1 MWh
U4-13 (07CF)	Peak Hold Current	Current PeakHold	Displays the highest current value that occurred during run.	No signal output available	0.01 A <3> <4> <5>
U4-14 (07D0)	Peak Hold Output Frequency	Freq@ I PeakHold	Displays the output frequency when the current value shown in U4-13 occurred.	No signal output available	0.01 Hz
U4-16 (07D8)	Motor Overload Estimate (oL1)	Motor OL1 Level	Shows the value of the motor overload detection accumulator. 100% is equal to the oL1 detection level.	10 V: 100%	0.1%
U4-18 (07DA)	Frequency Reference Source Selection	Reference Source	Displays the source for the frequency reference as XY-nn. X: indicates which reference is used: 1 = Reference 1 (b1-01) 2 = Reference 2 (b1-15) Y-nn: indicates the reference source 0-01 = Digital operator 1-00 = Analog 1-01 = Analog (terminal A1) 1-02 = Analog (terminal A2) 1-03 = Analog (terminal A3) 2-02 to 17 = Multi-step speed (d1-02 to 17) 3-01 = MEMOBUS/Modbus communications 4-01 = Communication option card 5-01 = Pulse input 9-01 = Up/Down Command	No signal output available	–
U4-19 (07DB)	Frequency Reference from MEMOBUS/Modbus Comm.	MEMOBUS Freq Ref	Displays the frequency reference provided by MEMOBUS/Modbus (decimal).	No signal output available	0.01%
U4-20 (07DC)	Option Frequency Reference	Option Freq Ref	Displays the frequency reference input by an option card (decimal).	No signal output available	–
U4-21 (07DD)	Run Command Source Selection	Run Cmd Source	Displays the source for the Run command as XY-nn. X: Indicates which Run source is used: 1 = Reference 1 (b1-02) Y: Input power supply data 0 = Digital operator 1 = External terminals 3 = MEMOBUS/Modbus communications 4 = Communication option card nn: Run command limit status data 00: No limit status. 01: Run command was left on when stopped in the PRG mode 02: Run command was left on when switching from LOCAL to REMOTE operation 03: Waiting for soft charge bypass contactor after power up (Uv or Uv1 flashes after 10 s) 04: Waiting for “Run command prohibited” time period to end 05: Fast Stop (digital input, digital operator) 06: b1-17 (Run command given at power-up) 07: During baseblock while coast to stop with timer 08: Frequency reference is below minimal reference during baseblock 09: Waiting for Enter command 10: Run command was switched on while copying parameters. 12: Clock is being reset for the RTC.	No signal output available	–
U4-22 (07DE)	MEMOBUS/Modbus Communications Reference	MEMOBUS Ref Reg	Displays the drive control data set by MEMOBUS/Modbus communications register no. 0001H as a four-digit hexadecimal number.	No signal output available	–
U4-23 (07DF)	Communication Option Card Reference	Option Ref Reg	Displays drive control data set by an option card as a four-digit hexadecimal number.	No signal output available	–
U4-24 (07E0)	Number of Travels (L)	Number of Travels (L)	–	No signal output available	–

No. (Addr. Hex)	Name	LCD Display	Description	Analog Output Level	Unit
U4-25 (07E1)	Number of Travels (H)	Number of Travels (H)	-	No signal output available	-

- <1> The MEMOBUS/Modbus communications data is in 10 h units. If data in 1 h units are also required, refer to register number 0099H.
- <2> The MEMOBUS/Modbus communications data is in 10 h units. If data in 1 h units are also required, refer to register number 009BH.
- <3> Display is in the following units:
 2□0028, 2□0042, and 4□0011 to 4□0027: 0.01 A units
 2□0054 to 2□0248 and 4□0034 to 4□0720: 0.1 A units
 4□0930: 1 A units
- <4> The values of U1-03, U2-05, and U4-13 are displayed on the digital operator in units of amperes. When those monitors are checked using MEMOBUS/Modbus communications, the monitor values in MEMOBUS/Modbus communications are displayed as: numeric value / 8192 × drive rated current (A) from the condition “192 (maximum value) = drive rated current (A)”
- <5> When reading the value of this monitor via MEMOBUS/Modbus a value of 8192 is equal to 100% of the drive rated output current.

◆ U5: PID Monitors

No. (Addr. Hex)	Name	LCD Display	Description	Analog Output Level	Unit
U5-01 (0057)	PID Feedback	PID Feedback 1	Displays the PID feedback value.	10 V: 100% (-10 to +10 V)	0.01% <I>
U5-02 (0063)	PID Input	PID Input	Displays the amount of PID input (deviation between PID setpoint and feedback).	10 V: 100% (-10 to +10 V)	0.01%
U5-03 (0064)	PID Output	PID Output	Displays PID control output.	10 V: 100% (-10 to +10 V)	0.01%
U5-04 (0065)	PID Setpoint	PID Setpoint	Displays the PID setpoint.	10 V: 100% (-10 to +10 V)	0.01% <I>
U5-05 (07D2)	PID Differential Feedback	PID Feedback 2	Displays the 2nd PID feedback value if differential feedback is used (H3-□□ = 16).	10 V: 100% (-10 to +10 V)	0.01%
U5-06 (07D3)	PID Adjusted Feedback	PID Diff Fdbk	Displays the difference of both feedback values if differential feedback is used (U5-01 - U5-05). If differential feedback is not used, then U5-01 and U5-06 will be the same.	10 V: 100% (-10 to +10 V)	0.01%
U5-14 (086B)	PI Output 2 Upper 4 Digits	PI Output2 U4	Displays the custom PI output. U5-14 shows the upper 4 digits while U5-15 shows the lower 4 digits. Monitors are scaled by b5-43 and b5-44.	No signal output available	1 <2>
U5-15 (086C)	PI Output 2 Lower 4 Digits	PI Output2 L4	Displays the custom PI output. U5-14 shows the upper 4 digits while U5-15 shows the lower 4 digits. Monitors are scaled by b5-43 and b5-44.	No signal output available	0.01 <2>
U5-30 (3000)	Time Hr Min HHMM	Time Hr Min HHMM	Displays the current time (Hours and Minutes).	No signal output available	1
U5-31 (3001)	Date Year	Date Year	Displays the current year.	No signal output available	1
U5-32 (3002)	Date Mo Day MMDD	Date Mo Day MMDD	Displays the current date (Month and Day).	No signal output available	1
U5-33 (3003)	Date Week 000W	Date Week 0: Sunday 1: Monday 2: Tuesday 3: Wednesday 4: Thursday 5: Friday 6: Saturday	Displays the current date of the week. 0: Sunday 1: Monday 2: Tuesday 3: Wednesday 4: Thursday 5: Friday 6: Saturday	No signal output available	1
U5-99 (1599)	AUTO Setpoint	Auto Setpoint	Displays the PID Setpoint commanded by the source when the drive is in AUTO Mode.	No signal output available	0.1 PSI <I>

- <1> Unit, range and resolution is determined by P1-02, P1-03 and b5-39.
- <2> Unit is determined by b5-41

Parameter List

◆ U6: Operation Status Monitors

No. (Addr. Hex)	Name	LCD Display	Description	Analog Output Level	Unit
U6-01 (0051)	Motor Secondary Current (Iq)	Mot SEC Current	Displays the value of the motor secondary current (Iq). Motor rated secondary current is 100%.	10 V: Motor secondary rated current (-10 to +10 V)	0.1%
U6-02 (0052)	Motor Excitation Current (Id)	Mot EXC Current	OLV Displays the value calculated for the motor excitation current (Id). Motor rated secondary current is 100%.	10 V: Motor secondary rated current (-10 to +10 V)	0.1%
U6-05 (0059)	Output Voltage Reference (Vq)	Voltage Ref (Vq)	OLV Output voltage reference (Vq) for the q-Axis.	10 V: 200 Vrms (-10 to +10 V) </>	0.1 Vac
U6-06 (005A)	Output Voltage Reference (Vd)	Voltage Ref (Vd)	OLV Output voltage reference (Vd) for the d-Axis.	10 V: 200 Vrms (-10 to +10 V) </>	0.1 Vac
U6-07 (005F)	q-Axis ACR Output	ACR(q) Output	OLV Displays the output value for current(q) control relative to motor secondary current (q-Axis).	10 V: 200 Vrms (-10 to +10 V) </>	0.1%
U6-08 (0060)	d-Axis ACR Output	ACR(d) Output	OLV Displays the output value for current control relative to motor secondary current (d-Axis).	110 V: 200 Vrms (-10 to +10 V) </>	0.1%
U6-80 to U6-83 (07B0H to 07B3)	Online IP Address	–	IP Address currently available; U6-80 is the most significant octet.	No signal output available	–
U6-84 to U6-87 (07B4 to 07B7)	Online Subnet	–	Subnet currently available; U6-84 is the most significant octet.	No signal output available	–
U6-88 to U6-91 (07B8 to 07F1)	Online Gateway	–	Gateway currently available; U6-88 is the most significant octet.	No signal output available	–
U6-92 (07F2)	Online Speed	–	Link Speed	10: 10 Mbps 100: 100 Mbps	–
U6-93 (07F3)	Online Duplex	–	Duplex Setting	0: Half 1: Full	–
U6-98 (07F8)	First Fault	–	First Option Fault	–	–
U6-99 (07F9)	Current Fault	–	Current Option Fault	–	–

<1> Values shown are specific to 200 V class drives. Double the values for 400 V class drives.

◆ U9: Power Monitors

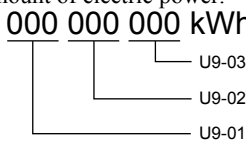
No. (Addr. Hex)	Name	LCD Display	Description	Analog Output Level	Unit
U9-01 (0820)	Electric Power (GWh)	GWh Consumed	Shows the total amount of electric power. 000 000 000 kWh 	No signal output available	1 GWh
U9-02 (0821)	Electric Power (MWh)	MWh Consumed		No signal output available	1 MWh
U9-03 (0822)	Electric Power (kWh)	kWh Consumed		No signal output available	1 kWh

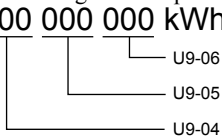
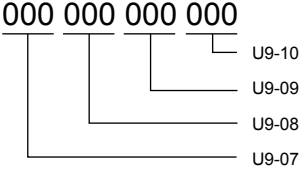
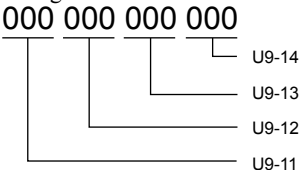
No. (Addr. Hex)	Name	LCD Display	Description	Analog Output Level	Unit
U9-04 (0823)	Regenerative Power (GWh)	GWh Produced	Shows the total amount of regenerated power. 000 000 000 kWh 	No signal output available	1 GWh
U9-05 (0824)	Regenerative Power (MWh)	MWh Produced		No signal output available	1 MWh
U9-06 (0825)	Regenerative Power (kWh)	kWh Produced		No signal output available	1 kWh
U9-07 to U9-10 (0826 to 0829)	Electric Power Rates 1 to 4	Consumed □ (\$)	These parameters show the electric power rate in Power Unit Price (o4-19) that is calculated from the total electrical power consumptions in U9-01 to U9-03. U9-10: Digit 1 to digit 3 U9-09: Digit 4 to digit 6 U9-08: Digit 7 to digit 9 U9-07: Digit 10 to digit 12 000 000 000 000  <p>The unit price is set in o4-19, and U9-07 to U9-10 are U9-01 to U9-03 x o4-19.</p>	No signal output available	-
U9-11 to U9-14 (082A to 082D)	Regenerative Power Rates 1 to 4	Produced □ (\$)	These parameters show the regenerative power rate in Power Unit Price (o4-19) that is calculated from the total electrical power consumptions in U9-04 to U9-06. U9-14: Digit 1 to digit 3 U9-13: Digit 4 to digit 6 U9-12: Digit 7 to digit 9 U9-11: Digit 10 to digit 12 000 000 000 000  <p>The unit price is set in o4-19, and U9-11 to U9-14 are U9-04 to U9-06 x o4-19.</p>	No signal output available	-

B.17 Parameter Default Values Changed by Control Mode

The tables below list parameters that depend on the control mode selection. Changing the control mode initializes these parameters to the values shown here.

Table B.2 A1-02 Dependent Parameters and Default Values

No.	Name	Setting Range	Resolution	Control Modes (A1-02)	
				V/f (0)	OLV (2)
b1-24	Commercial Power Switching Selection	0, 1	–	0	–
b3-08	Current Control Gain during Speed Search (Speed Estimation Type)	0.00 to 6.00	–	<1>	<1>
b8-02	Energy Saving Gain	0.0 to 10.0	0.1	–	0.7
b8-03	Energy Saving Control Filter Time Constant	0.00 to 10.00	0.01 s	–	0.50 <2>
C3-01	Slip Compensation Gain	0.0 to 2.5	0.1	0.0	1.0
C3-02	Slip Compensation Primary Delay Time	0 to 10000	1 ms	2000	200
C4-02	Torque Compensation Primary Delay Time	0 to 10000	1 ms	200	20
C6-02	Carrier Frequency Selection	0 to 4; F	–	1 <4>	1 <1>
E1-05	Maximum Voltage	0.0 to 255.0 <4>	0.1 V	230 <4>	575
E1-08	Middle Output Frequency Voltage	0.0 to 255.0 <4>	0.1 V	<5>	<5>
E1-09	Minimum Output Frequency	0.0 to 400.0	0.1 Hz	1.5	0.5
E1-10	Minimum Output Frequency Voltage	0.0 to 255.0 <4>	0.1 V	<5>	<5>
L3-36	Vibration Suppression Gain during Acceleration (with Current Limit)	0.0 to 100.0	–	10.0	20.0
L3-41	Vibration Suppression Gain during Deceleration (with Current Limit)	0.0 to 100.0	–	10.0	20.0
L8-18	Software Current Limit Selection	0, 1	–	1	0
L8-38	Carrier Frequency Reduction Selection	0 to 2	–	<1>	<1>

<1> Default setting value is determined by parameter o2-04, Drive Model Selection.

<2> This setting value depends on rated output current in models 2□0248 and 4□0165 to 4□0414: 2.00 in Open Loop Vector Control.

<4> Values shown are specific to 200 V class drives. Double the values for 400 V class drives.

<5> This setting value depends on rated output current and V/f pattern selection in parameter E1-03.

B.18 V/f Pattern Default Values

Table B.3 to Table B.5 show the V/f pattern setting default values depending on the control mode and V/f pattern selection (A1-02 and E1-03).

Table B.3 E1-03 V/f Pattern Settings for Drive Capacity: Models 4□0011 and 4□0014

No.	Unit	V/f Control																OLV
		0	1	2	3	4	5	6	7	8	9	A	B	C	D	E	F <1>	
E1-03	-	0	1	2	3	4	5	6	7	8	9	A	B	C	D	E	F <1>	OLV
E1-04	Hz	50.0	60.0	60.0	72.0	50.0	50.0	60.0	60.0	50.0	50.0	60.0	60.0	90.0	120.0	180.0	60.0	60.0
E1-05 <2>	V	230.0	230.0	230.0	230.0	230.0	230.0	230.0	230.0	230.0	230.0	230.0	230.0	230.0	230.0	230.0	230.0	230.0
E1-06	Hz	50.0	60.0	50.0	60.0	50.0	50.0	60.0	60.0	50.0	50.0	60.0	60.0	60.0	60.0	60.0	60.0	60.0
E1-07	Hz	2.5	3.0	3.0	3.0	25.0	25.0	30.0	30.0	2.5	2.5	3.0	3.0	3.0	3.0	3.0	3.0	3.0
E1-08 <2>	V	17.3	17.3	17.3	17.3	40.3	57.5	40.3	57.5	21.9	27.6	21.9	27.6	17.3	17.3	17.3	17.3	13.8
E1-09	Hz	1.3	1.5	1.5	1.5	1.3	1.3	1.5	1.5	1.3	1.3	1.5	1.5	1.5	1.5	1.5	1.5	0.5
E1-10 <2>	V	10.4	10.4	10.4	10.4	9.2	10.4	9.2	10.4	12.7	15.0	12.7	17.3	10.4	10.4	10.4	10.2	2.9

<1> This value determines the default values for E1-04 through E1-10.

<2> Values shown here are specific to 200 V class drives. Double the value for 400 V class drives.

Table B.4 E1-03 V/f Pattern Settings for Drive Capacity: Models 2□0028 to 2□0192 and 4□0021 to 4□0124

No.	Unit	V/f Control																OLV
		0	1	2	3	4	5	6	7	8	9	A	B	C	D	E	F <1>	
E1-03	-	0	1	2	3	4	5	6	7	8	9	A	B	C	D	E	F <1>	OLV
E1-04	Hz	50.0	60.0	60.0	72.0	50.0	50.0	60.0	60.0	50.0	50.0	60.0	60.0	90.0	120.0	180.0	60.0	60.0
E1-05 <2>	V	230.0	230.0	230.0	230.0	230.0	230.0	230.0	230.0	230.0	230.0	230.0	230.0	230.0	230.0	230.0	230.0	230.0
E1-06	Hz	50.0	60.0	50.0	60.0	50.0	50.0	60.0	60.0	50.0	50.0	60.0	60.0	60.0	60.0	60.0	60.0	60.0
E1-07	Hz	2.5	3.0	3.0	3.0	25.0	25.0	30.0	30.0	2.5	2.5	3.0	3.0	3.0	3.0	3.0	3.0	3.0
E1-08 <2>	V	16.1	16.1	16.1	16.1	40.3	57.5	40.3	57.5	20.7	26.5	20.7	26.5	16.1	16.1	16.1	16.1	12.7
E1-09	Hz	1.3	1.5	1.5	1.5	1.3	1.3	1.5	1.5	1.3	1.3	1.5	1.5	1.5	1.5	1.5	1.5	0.5
E1-10 <2>	V	8.1	8.1	8.1	8.1	6.9	8.1	6.9	8.1	10.4	12.7	10.4	15.0	8.1	8.1	8.1	8.1	2.3

<1> This value determines the default values for E1-04 through E1-10.

<2> Values shown here are specific to 200 V class drives. Double the value for 400 V class drives.

Table B.5 E1-03 V/f Pattern Settings for Drive Capacity: Models 2□0248 and 4□0156 to 4□0930

No.	Unit	V/f Control																OLV
		0	1	2	3	4	5	6	7	8	9	A	B	C	D	E	F <1>	
E1-03	-	0	1	2	3	4	5	6	7	8	9	A	B	C	D	E	F <1>	OLV
E1-04	Hz	50.0	60.0	60.0	72.0	50.0	50.0	60.0	60.0	50.0	50.0	60.0	60.0	90.0	120.0	180.0	60.0	60.0
E1-05 <2>	V	230.0	230.0	230.0	230.0	230.0	230.0	230.0	230.0	230.0	230.0	230.0	230.0	230.0	230.0	230.0	230.0	230.0
E1-06	Hz	50.0	60.0	50.0	60.0	50.0	50.0	60.0	60.0	50.0	50.0	60.0	60.0	60.0	60.0	60.0	60.0	60.0
E1-07	Hz	2.5	3.0	3.0	3.0	25.0	25.0	30.0	30.0	2.5	2.5	3.0	3.0	3.0	3.0	3.0	3.0	3.0
E1-08 <2>	V	13.8	13.8	13.8	13.8	40.3	57.5	40.3	57.5	17.3	23.0	17.3	23.0	13.8	13.8	13.8	13.8	12.7
E1-09	Hz	1.3	1.5	1.5	1.5	1.3	1.3	1.5	1.5	1.3	1.3	1.5	1.5	1.5	1.5	1.5	1.5	0.5
E1-10 <2>	V	6.9	6.9	6.9	6.9	5.8	6.9	5.8	6.9	8.1	10.4	8.1	12.7	6.9	6.9	6.9	6.9	2.3

<1> This value determines the default values for E1-04 through E1-10.

<2> Values shown here are specific to 200 V class drives. Double the value for 400 V class drives.

B.19 Defaults by Drive Model

The following tables show parameters and default settings that change with the drive model selection (o2-04).

Table B.6 200 V Class Drives Default Settings by Drive Model Selection

No.	Name	Unit	2□0028	2□0042	2□0054	2□0068
–	Drive Model	–	2□0028	2□0042	2□0054	2□0068
o2-04	Drive Model Selection	Hex.	6A	6B	6D	6E
E2-11	Motor Rated Output	kW (HP)	7.5 (10)	11 (15)	15 (20)	18.5 (25)
b3-04	V/f Gain during Speed Search	%	100	100	100	100
b3-06	Output Current I during Speed Search	–	0.5	0.5	0.5	0.5
b3-08	Current Control Gain during Speed Search (Speed Estimation Type)	–	0.5	0.5	0.5	0.5
b8-03	Energy Saving Control Filter Time Constant	s	0.50	0.50	0.50	0.50
b8-04	Energy Saving Coefficient Value	–	72.69	70.44	63.13	57.87
C6-02	Carrier Frequency Selection	–	1	1	1	1
E2-01	Motor Rated Current	A	26.6	39.7	53	65.8
E2-02	Motor Rated Slip	Hz	1.3	1.7	1.6	1.67
E2-03	Motor No-Load Current	A	8	11.2	15.2	15.7
E2-05	Motor Line-to-Line Resistance	Ω	0.288	0.23	0.138	0.101
E2-06	Motor Leakage Inductance	%	15.5	19.5	17.2	20.1
E2-10	Motor Iron Loss for Torque Compensation	W	262	245	272	505
L2-02	Momentary Power Loss Ride-Thru Time	s	0.8	0.9	1	1
L2-03	Momentary Power Loss Minimum Baseblock Time	s	0.3	0.3	0.6	0.6
L2-04	Momentary Power Loss Voltage Recovery Time	s	150	150	150	150
L2-21	Low Input Voltage Detection Level	V	150	150	150	150
L8-02	Overheat Alarm Level	°C	130	130	130	130
L8-35	Installation Method Selection	–	0	0	0	0
L8-38	Carrier Frequency Reduction Selection	–	1	1	1	1
n1-03	Hunting Prevention Time Constant	ms	10	10	10	10

Table B.7 200 V Class Drives Default Settings by Drive Model Selection

No.	Name	Unit	2□0081	2□0104	2□0130	2□0154
–	Drive Model	–	2□0081	2□0104	2□0130	2□0154
o2-04	Drive Model Selection	Hex.	6F	70	72	73
E2-11	Motor Rated Output	kW (HP)	22 (30)	30 (40)	37 (50)	45 (60)
b3-04	V/f Gain during Speed Search	%	100	80	80	80
b3-06	Output Current I during Speed Search	–	0.5	0.5	0.5	0.5
b3-08	Current Control Gain during Speed Search (Speed Estimation Type)	–	0.5	0.5	0.5	0.5
b8-03	Energy Saving Control Filter Time Constant	s	0.50	0.50	0.50	0.50
b8-04	Energy Saving Coefficient Value	–	51.79	46.27	38.16	35.78
C6-02	Carrier Frequency Selection	–	1	1	1	1
E2-01	Motor Rated Current	A	77.2	105	131	160
E2-02	Motor Rated Slip	Hz	1.7	1.8	1.33	1.6
E2-03	Motor No-Load Current	A	18.5	21.9	38.2	44
E2-05	Motor Line-to-Line Resistance	Ω	0.079	0.064	0.039	0.03
E2-06	Motor Leakage Inductance	%	19.5	20.8	18.8	20.2
E2-10	Motor Iron Loss for Torque Compensation	W	538	699	823	852
L2-02	Momentary Power Loss Ride-Thru Time	s	1	1.1	1.1	1.2
L2-03	Momentary Power Loss Minimum Baseblock Time	s	0.6	0.6	0.6	1
L2-04	Momentary Power Loss Voltage Recovery Time	s	150	150	150	150
L2-21	Low Input Voltage Detection Level	V	150	150	150	150
L8-02	Overheat Alarm Level	°C	130	130	130	130

No.	Name	Unit				
-	Drive Model	-	2□0081	2□0104	2□0130	2□0154
o2-04	Drive Model Selection	Hex.	6F	70	72	73
E2-11	Motor Rated Output	kW (HP)	22 (30)	30 (40)	37 (50)	45 (60)
L8-35	Installation Method Selection	-	0	0	0	0
L8-38	Carrier Frequency Reduction Selection	-	1	1	1	1
n1-03	Hunting Prevention Time Constant	ms	10	10	10	10

Table B.8 200 V Class Drives Default Settings by Drive Model Selection

No.	Name	Unit		
-	Drive Model	-	2□0192	2□0248
o2-04	Drive Model Selection	Hex.	74	75
E2-11	Motor Rated Output	kW (HP)	55 (75)	75 (100)
b3-04	V/f Gain during Speed Search	%	80	80
b3-06	Output Current I during Speed Search	-	0.5	0.7
b3-08	Current Control Gain during Speed Search (Speed Estimation Type)	-	0.5	0.5
b8-03	Energy Saving Control Filter Time Constant	s	2.00	2.00
b8-04	Energy Saving Coefficient Value	-	31.35	23.1
C6-02	Carrier Frequency Selection	-	1	1
E2-01	Motor Rated Current	A	190	260
E2-02	Motor Rated Slip	Hz	1.43	1.39
E2-03	Motor No-Load Current	A	45.6	72
E2-05	Motor Line-to-Line Resistance	Ω	0.022	0.023
E2-06	Motor Leakage Inductance	%	20.5	20
E2-10	Motor Iron Loss for Torque Compensation	W	960	1200
L2-02	Momentary Power Loss Ride-Thru Time	s	1.3	1.5
L2-03	Momentary Power Loss Minimum Baseblock Time	s	1	1
L2-04	Momentary Power Loss Voltage Recovery Time	s	150	150
L2-21	Low Input Voltage Detection Level	V	150	150
L8-02	Overheat Alarm Level	°C	130	130
L8-35	Installation Method Selection	-	0	0
L8-38	Carrier Frequency Reduction Selection	-	1	1
n1-03	Hunting Prevention Time Constant	ms	10	10

Table B.9 400 V Class Drives Default Settings by Drive Model Selection

No.	Name	Unit				
-	Drive Model	-	4□0011	4□0014	4□0021	4□0027
o2-04	Drive Model Selection	Hex.	95	97	99	9A
E2-11	Motor Rated Output	kW (HP)	5.5 (7.5)	7.5 (10)	11 (15)	15 (20)
b3-04	V/f Gain during Speed Search	%	100	100	100	100
b3-06	Output Current I during Speed Search	-	0.5	0.5	0.5	0.5
b3-08	Current Control Gain during Speed Search (Speed Estimation Type)	-	0.5	0.5	0.5	0.5
b8-03	Energy Saving Control Filter Time Constant	s	0.50	0.50	0.50	0.50
b8-04	Energy Saving Coefficient Value	-	245.8	189.5	145.38	140.88
C6-02	Carrier Frequency Selection	-	1	1	1	1
E2-01	Motor Rated Current	A	7	9.8	13.3	19.9
E2-02	Motor Rated Slip	Hz	2.7	1.5	1.3	1.7
E2-03	Motor No-Load Current	A	2.3	2.6	4	5.6
E2-05	Motor Line-to-Line Resistance	Ω	3.333	1.595	1.152	0.922
E2-06	Motor Leakage Inductance	%	19.3	18.2	15.5	19.6
E2-10	Motor Iron Loss for Torque Compensation	W	130	193	263	385
L2-02	Momentary Power Loss Ride-Thru Time	s	0.6	0.7	0.8	0.9

B.19 Defaults by Drive Model

No.	Name	Unit	4□0011	4□0014	4□0021	4□0027
–	Drive Model	–	4□0011	4□0014	4□0021	4□0027
o2-04	Drive Model Selection	Hex.	95	97	99	9A
E2-11	Motor Rated Output	kW (HP)	5.5 (7.5)	7.5 (10)	11 (15)	15 (20)
L2-03	Momentary Power Loss Minimum Baseblock Time	s	0.3	0.3	0.3	0.3
L2-04	Momentary Power Loss Voltage Recovery Time	s	300	300	300	300
L2-21	Low Input Voltage Detection Level	V	300	300	300	300
L8-02	Overheat Alarm Level	°C	130	130	130	130
L8-35	Installation Method Selection	–	0	0	0	0
L8-38	Carrier Frequency Reduction Selection	–	1	1	1	1
n1-03	Hunting Prevention Time Constant	ms	10	10	10	10

Table B.10 400 V Class Drives Default Settings by Drive Model Selection

No.	Name	Unit	4□0034	4□0040	4□0052	4□0065
–	Drive Model	–	4□0034	4□0040	4□0052	4□0065
o2-04	Drive Model Selection	Hex.	9C	9D	9E	9F
E2-11	Motor Rated Output	kW (HP)	18.5 (25)	22 (30)	30 (40)	37 (50)
b3-04	V/f Gain during Speed Search	%	100	100	100	100
b3-06	Output Current I during Speed Search	–	0.5	0.5	0.5	0.5
b3-08	Current Control Gain during Speed Search (Speed Estimation Type)	–	0.5	0.5	0.5	0.5
b8-03	Energy Saving Control Filter Time Constant	s	0.50	0.50	0.50	0.50
b8-04	Energy Saving Coefficient Value	–	126.26	115.74	103.58	92.54
C6-02	Carrier Frequency Selection	–	1	1	1	1
E2-01	Motor Rated Current	A	26.5	32.9	38.6	52.3
E2-02	Motor Rated Slip	Hz	1.6	1.67	1.7	1.8
E2-03	Motor No-Load Current	A	7.6	7.8	9.2	10.9
E2-05	Motor Line-to-Line Resistance	Ω	0.55	0.403	0.316	0.269
E2-06	Motor Leakage Inductance	%	17.2	20.1	23.5	20.7
E2-10	Motor Iron Loss for Torque Compensation	W	440	508	586	750
L2-02	Momentary Power Loss Ride-Thru Time	s	1	1	1	1.1
L2-03	Momentary Power Loss Minimum Baseblock Time	s	0.6	0.6	0.6	0.6
L2-04	Momentary Power Loss Voltage Recovery Time	s	300	300	300	300
L2-21	Low Input Voltage Detection Level	V	300	300	300	300
L8-02	Overheat Alarm Level	°C	130	130	130	130
L8-35	Installation Method Selection	–	0	0	0	0
L8-38	Carrier Frequency Reduction Selection	–	1	1	1	1
n1-03	Hunting Prevention Time Constant	ms	10	10	10	10

Table B.11 400 V Class Drives Default Settings by Drive Model Selection

No.	Name	Unit	4□0077	4□0096	4□0124	4□0156
–	Drive Model	–	4□0077	4□0096	4□0124	4□0156
o2-04	Drive Model Selection	Hex.	A1	A2	A3	A4
E2-11	Motor Rated Output	kW (HP)	45 (60)	55 (75)	75 (100)	90 (125)
b3-04	V/f Gain during Speed Search	%	100	100	80	60
b3-06	Output Current I during Speed Search	–	0.5	0.5	0.5	0.7
b3-08	Current Control Gain during Speed Search (Speed Estimation Type)	–	0.5	0.5	0.5	0.8
b8-03	Energy Saving Control Filter Time Constant	s	0.50	0.50	2.00	2.00
b8-04	Energy Saving Coefficient Value	–	76.32	71.56	67.2	46.2
C6-02	Carrier Frequency Selection	–	1	1	1	1
E2-01	Motor Rated Current	A	65.6	79.7	95	130
E2-02	Motor Rated Slip	Hz	1.33	1.6	1.46	1.39
E2-03	Motor No-Load Current	A	19.1	22	24	36

No.	Name	Unit				
-	Drive Model	-	4□0077	4□0096	4□0124	4□0156
o2-04	Drive Model Selection	Hex.	A1	A2	A3	A4
E2-11	Motor Rated Output	kW (HP)	45 (60)	55 (75)	75 (100)	90 (125)
E2-05	Motor Line-to-Line Resistance	Ω	0.155	0.122	0.088	0.092
E2-06	Motor Leakage Inductance	%	18.8	19.9	20	20
E2-10	Motor Iron Loss for Torque Compensation	W	925	1125	1260	1600
L2-02	Momentary Power Loss Ride-Thru Time	s	1.1	1.2	1.2	1.3
L2-03	Momentary Power Loss Minimum Baseblock Time	s	0.6	0.6	1	1
L2-04	Momentary Power Loss Voltage Recovery Time	s	300	300	300	300
L2-21	Low Input Voltage Detection Level	V	300	300	300	300
L8-02	Overheat Alarm Level	°C	130	130	130	130
L8-35	Installation Method Selection	-	0	0	0	0
L8-38	Carrier Frequency Reduction Selection	-	1	1	1	1
n1-03	Hunting Prevention Time Constant	ms	10	10	10	30

Table B.12 400 V Class Drives Default Settings by Drive Model Selection

No.	Name	Unit				
-	Drive Model	-	4□0180	4□0216	4□0240	4□0302
o2-04	Drive Model Selection	Hex.	A5	A6	A7	A8
E2-11	Motor Rated Output	kW (HP)	110 (150)	132 (175)	150 (200)	185 (250)
b3-04	V/f Gain during Speed Search	%	60	60	60	60
b3-06	Output Current I during Speed Search	-	0.7	0.7	0.7	0.7
b3-08	Current Control Gain during Speed Search (Speed Estimation Type)	-	0.8	0.8	0.8	0.8
b8-03	Energy Saving Control Filter Time Constant	s	2.00	2.00	2.00	2.00
b8-04	Energy Saving Coefficient Value	-	38.91	36.23	32.79	30.13
C6-02	Carrier Frequency Selection	-	1	1	1	1
E2-01	Motor Rated Current	A	156	190	223	270
E2-02	Motor Rated Slip	Hz	1.4	1.4	1.38	1.35
E2-03	Motor No-Load Current	A	40	49	58	70
E2-05	Motor Line-to-Line Resistance	Ω	0.056	0.046	0.035	0.029
E2-06	Motor Leakage Inductance	%	20	20	20	20
E2-10	Motor Iron Loss for Torque Compensation	W	1760	2150	2350	2850
L2-02	Momentary Power Loss Ride-Thru Time	s	1.5	1.7	1.7	1.8
L2-03	Momentary Power Loss Minimum Baseblock Time	s	1	1	1	1
L2-04	Momentary Power Loss Voltage Recovery Time	s	300	300	300	300
L2-21	Low Input Voltage Detection Level	V	300	300	300	300
L8-02	Overheat Alarm Level	°C	130	130	130	130
L8-35	Installation Method Selection	-	0	0	0	0
L8-38	Carrier Frequency Reduction Selection	-	1	1	1	1
n1-03	Hunting Prevention Time Constant	ms	30	30	30	30

Table B.13 400 V Class Drives Default Settings by Drive Model Selection

No.	Name	Unit	Default Settings			
-	Drive Model	-	4□0361	4□0414	4□0477	4□0590
o2-04	Drive Model Selection	Hex.	A9	AA	AC	AD
E2-11	Motor Rated Output	kW (HP)	220 (300)	260 (350)	300 (400)	375 (500)
b3-04	V/f Gain during Speed Search	%	60	60	60	60
b3-06	Output Current I during Speed Search	-	0.7	0.7	0.7	0.7
b3-08	Current Control Gain during Speed Search (Speed Estimation Type)	-	0.8	0.8	0.8	0.8
b8-03	Energy Saving Control Filter Time Constant	s	2.00	2.00	2.00	2.00
b8-04	Energy Saving Coefficient Value	-	30.57	27.13	21.76	21.76

B.19 Defaults by Drive Model

No.	Name	Unit	Default Settings			
			4□0361	4□0414	4□0477	4□0590
–	Drive Model	–	A9	AA	AC	AD
o2-04	Drive Model Selection	Hex.	A9	AA	AC	AD
E2-11	Motor Rated Output	kW (HP)	220 (300)	260 (350)	300 (400)	375 (500)
C6-02	Carrier Frequency Selection	–	1	1	0	0
E2-01	Motor Rated Current	A	310	370	500	500
E2-02	Motor Rated Slip	Hz	1.3	1.3	1.25	1.25
E2-03	Motor No-Load Current	A	81	96	130	130
E2-05	Motor Line-to-Line Resistance	Ω	0.025	0.02	0.014	0.014
E2-06	Motor Leakage Inductance	%	20	20	20	20
E2-10	Motor Iron Loss for Torque Compensation	W	3200	3700	4700	4700
L2-02	Momentary Power Loss Ride-Thru Time	s	1.9	2	2.1	2.1
L2-03	Momentary Power Loss Minimum Baseblock Time	s	1	1	2.0	2.0
L2-04	Momentary Power Loss Voltage Recovery Time	s	300	300	300	300
L2-21	Low Input Voltage Detection Level	V	300	300	300	300
L8-02	Overheat Alarm Level	°C	130	130	130	130
L8-35	Installation Method Selection	–	0	0	0	0
L8-38	Carrier Frequency Reduction Selection	–	1	1	1	1
n1-03	Hunting Prevention Time Constant	ms	30	100	100	100

Table B.14 400 V Class Drives Default Settings by Drive Model Selection

No.	Name	Unit	Default Settings	
			4□0720	4□0930
–	Drive Model	–	AE	B0
o2-04	Drive Model Selection	Hex.	AE	B0
E2-11	Motor Rated Output	kW (HP)	375 (500)	500
b3-04	V/f Gain during Speed Search	%	60	60
b3-06	Output Current 1 during Speed Search	–	0.7	0.7
b3-08	Current Control Gain during Speed Search (Speed Estimation Type)	–	0.8	0.8
b8-03	Energy Saving Control Filter Time Constant	s	2	2
b8-04	Energy Saving Coefficient Value	–	23.84	20.26
C6-02	Carrier Frequency Selection	–	0	0
E2-01	Motor Rated Current	A	650	900
E2-02	Motor Rated Slip	Hz	1	0.9
E2-03	Motor No-Load Current	A	130	180
E2-05	Motor Line-to-Line Resistance	Ω	0.012	9.000 mΩ
E2-06	Motor Leakage Inductance	%	20	20
L2-02	Momentary Power Loss Ride-Thru Time	s	2.3	3.1
L2-03	Momentary Power Loss Minimum Baseblock Time	s	2.2	3
L2-04	Momentary Power Loss Voltage Recovery Time	s	300	300
L2-21	Low Input Voltage Detection Level	V	300	300
L8-02	Overheat Alarm Level	°C	135	135
L8-35	Installation Method Selection	–	0	0
L8-38	Carrier Frequency Reduction Selection	–	1	1
n1-03	Hunting Prevention Time Constant	ms	100	100

Appendix: C

MEMOBUS/Modbus Communications

C.1	MEMOBUS/MODBUS CONFIGURATION.....	416
C.2	COMMUNICATION SPECIFICATIONS.....	417
C.3	CONNECTING TO A NETWORK.....	418
C.4	MEMOBUS/MODBUS SETUP PARAMETERS.....	421
C.5	DRIVE OPERATIONS BY MEMOBUS/MODBUS.....	425
C.6	COMMUNICATIONS TIMING.....	426
C.7	MESSAGE FORMAT.....	427
C.8	MESSAGE EXAMPLES.....	429
C.9	MEMOBUS/MODBUS DATA TABLE.....	431
C.10	ENTER COMMAND.....	449
C.11	COMMUNICATION ERRORS.....	450
C.12	SELF-DIAGNOSTICS.....	451

C.1 MEMOBUS/Modbus Configuration

Drives can be controlled from a PLC or other master device via serial communications using the MEMOBUS/Modbus protocol. MEMOBUS/Modbus communications can be configured using one master (PLC) and up to 255 slaves. The drive has slave functionality only, and serial communication is normally initiated from the master and responded to by the slaves.

The master communicates with the specified slave drive. The address or node for each slave must be set prior so the master can communicate with the slave at that address. A slave that receives a command from the master will perform the specified function and send a response back to the master.

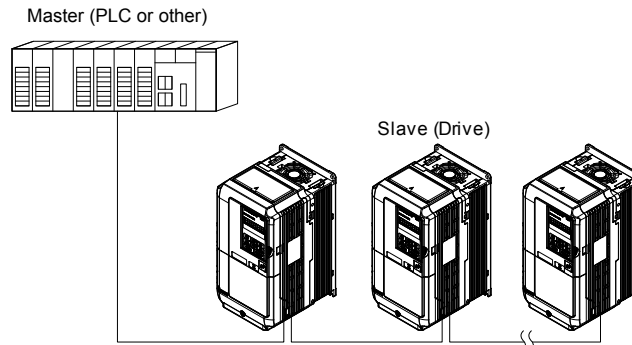

Figure C.1 Connecting Multiple Drives to a PLC

C.2 Communication Specifications

MEMOBUS/Modbus specifications appear in *Table C.1*:

Table C.1 MEMOBUS/Modbus Communications Specifications

Item	Specifications	
Interface	RS-422, RS-485	
Communications Cycle	Asynchronous (Start-stop synchronization)	
Communication Parameters	Communication Speeds Available	1.2; 2.4; 4.8; 9.6; 19.2; 38.4; 57.6; 76.8; 115.2 kbps
	Data length	8-bit (fixed)
	Parity	Select even, odd, or none
	Stop bit	1-bit (fixed)
Protocol	MEMOBUS/Modbus (using RTU mode only)	
Maximum Number of Slaves	31 drives (RS-485)	

C.3 Connecting to a Network

This section explains how to connect the drive to a MEMOBUS/Modbus network and the network termination required for a connection.

◆ Network Cable Connection

Follow the instructions below to connect the drive to a MEMOBUS/Modbus network.

1. With the power shut off, connect the communications cable to the drive and the master. Use terminals TB5 for MEMOBUS/Modbus.

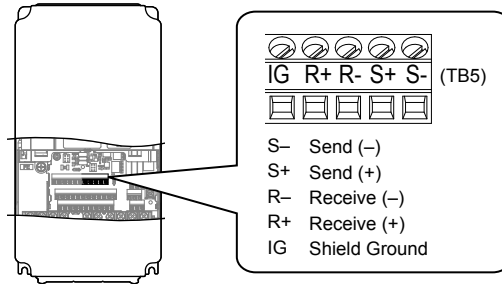

Figure C.2 Serial Communications Cable Connection Terminals (TB5)

Note: Separate the communications cables from the main circuit cables and other wiring and power cables. Use shielded cables for the communications cables, and properly shielded clamps to prevent problems with noise. When using RS-485 communications, connect S+ to R+, and S- to R- as shown in the diagram below.

2. Check or set the termination resistor selection at all slaves. Use the description in [Network Termination](#) on page 420 for slaves that are U1000 iQpump drives.
3. Switch the power on.
4. Set the parameters needed for serial communications (H5-01 through H5-12) using the HOA keypad.
5. Shut the power off and wait until the display on the HOA keypad goes out completely.
6. Turn the power back on.
7. The drive is now ready to begin communicating with the master.

◆ Wiring Diagram for Multiple Connections

Figure C.3 and *Figure C.4* explain the wiring diagrams for multiple connections using MEMOBUS/Modbus communication.

■ RS-485 Interface

Note: The isolated ground (IG) connection is optional but strongly recommended to improve network immunity to electrical interference.

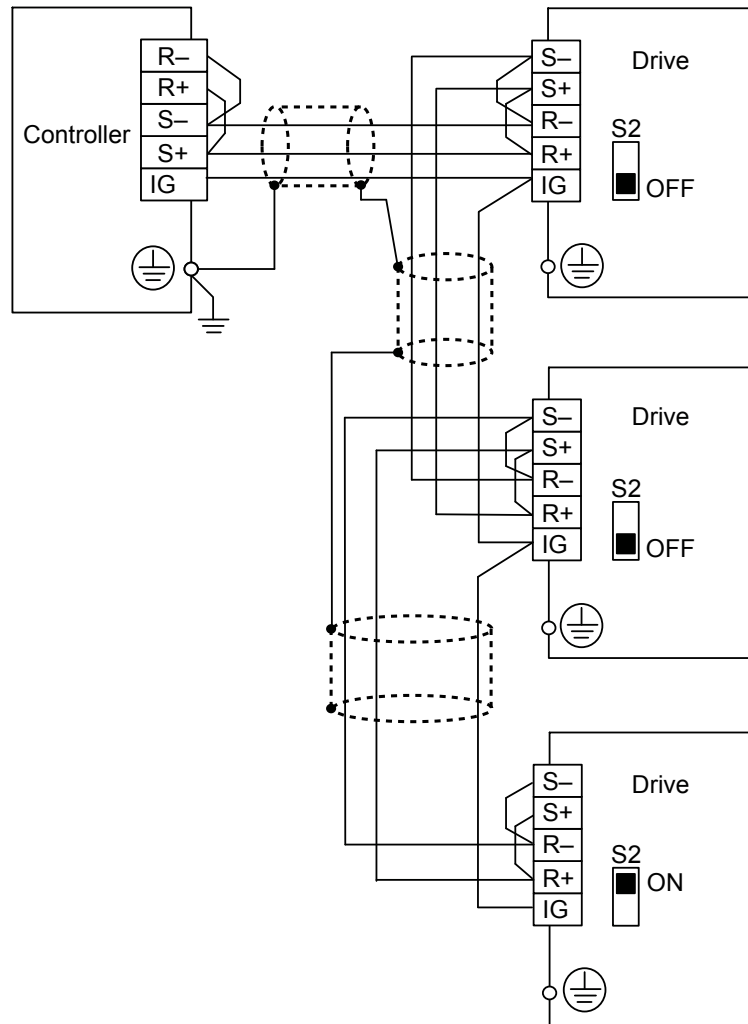

Figure C.3 RS-485 Interface

- Note:**
1. Set DIP switch S2 to the ON position on the drive located at the end of the network. Set DIP switch S2 to the OFF positions on all other slave devices.
 2. Set H5-07 to 1 when using the RS-485 interface.

■ RS-422 Interface

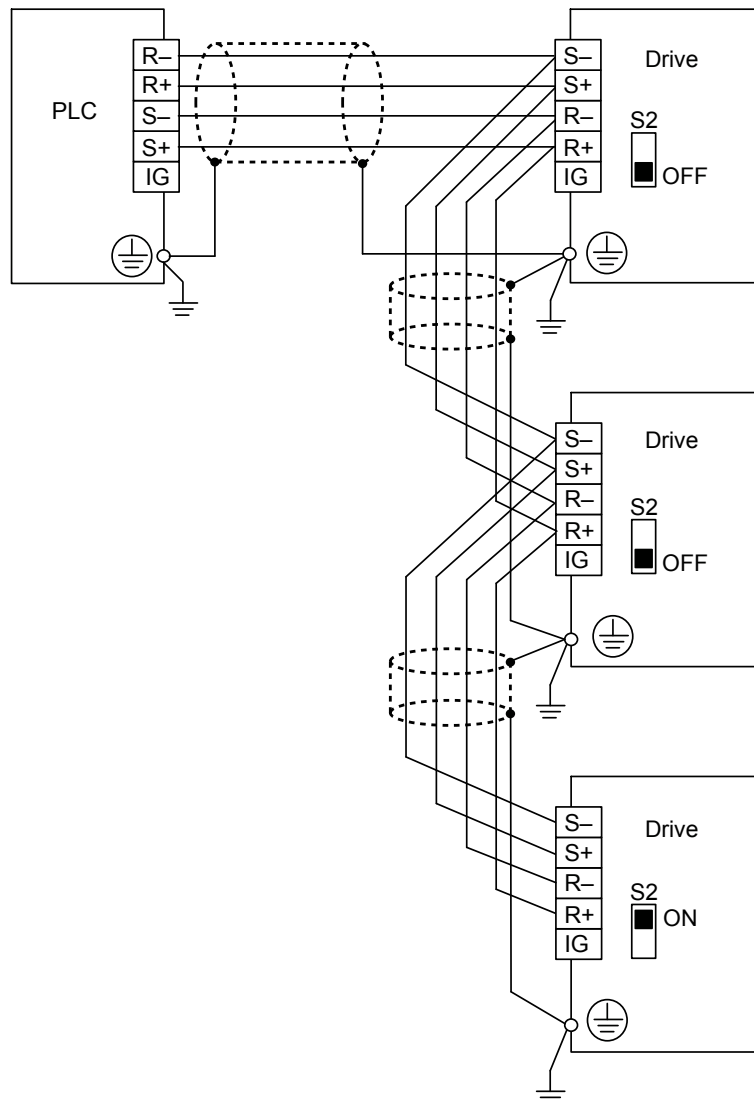

Figure C.4 RS-422 Interface

- Note:**
1. Set DIP switch S2 to the ON position on the drive located at the end of the network. Set DIP switch S2 to the OFF positions on all other slave devices.
 2. Set H5-07 to 1 when using the RS-422 interface in a multi-drop circuit.
Set H5-07 to 0 when using the RS-422 interface in a point-to-point circuit.

◆ Network Termination

The two ends of the MEMOBUS/Modbus network line have to be terminated. The drive has a built in termination resistor that can be enabled or disabled using DIP switch S2. If a drive is located at the end of a network line, enable the termination resistor by setting DIP switch S2 to the ON position. Disable the termination resistor on all slaves that are not located at the network line end.

C.4 MEMOBUS/Modbus Setup Parameters

◆ MEMOBUS/Modbus Serial Communication

Changes to MEMOBUS/Modbus communications settings become effective after restarting the drive.

■ H5-01: Drive Slave Address

Sets the drive slave address used for communications.

Note: Cycle power for the setting to take effect.

No.	Name	Setting Range	Default
H5-01	Drive Slave Address	0 to FF </>	1F

<1> If the address is set to 0, no response will be provided during communications.

Each slave drive must be assigned a unique slave address for serial communications to work. Setting H5-01 to any value besides 0 assigns the drive its address in the network. Slave addresses do not need to be assigned in sequential order, but no two drives may share the same address.

■ H5-02: Communication Speed Selection

Sets the MEMOBUS/Modbus communications speed.

Note: Cycle the power after changing this parameter to enable the new setting.

No.	Name	Setting Range	Default
H5-02	Communication Speed Selection	0 to 8	3

Setting 0: 1200 bps

Setting 1: 2400 bps

Setting 2: 4800 bps

Setting 3: 9600 bps

Setting 4: 19200 bps

Setting 5: 38400 bps

Setting 6: 57600 bps

Setting 7: 76800 bps

Setting 8: 115200 bps

■ H5-03: Communication Parity Selection

Sets the parity used for communications.

Note: Cycle power for the setting to take effect.

No.	Name	Setting Range	Default
H5-03	Communication Parity Selection	0 to 2	0

Setting 0: No parity

Setting 1: Even parity

Setting 2: Odd parity

C.4 MEMOBUS/Modbus Setup Parameters

■ H5-04: Stopping Method after Communication Error

Selects the stopping method after a MEMOBUS/Modbus communications error (CE) has occurred.

No.	Name	Setting Range	Default
H5-04	Stopping Method after CE	0 to 4	3

Setting 0: Ramp to stop (uses the deceleration time currently enabled)

Setting 1: Coast to stop

Setting 2: Fast Stop

Setting 3: Alarm only (continue operation)

Setting 4: Run at H5-14

This setting will trigger a “CE – Comm Loss” alarm and cause the drive to run at the speed set in H5-14 speed when a Communication Error (CE) occurs.

The drive faults on CE and coasts to stop when H5-15 > 0 and the CE condition persists for the time set in H5-15.

Note the following conditions when using this setting and a CE occurs:

- During Pre-charge, the drive will continue to run at the Pre-charge frequency
- During Sleep, the drive will wake up and run at the speed set in H5-14
- During Feedback Drop, the drive will wake up and run at the speed set in H5-14
- Lag pumps are deactivated when in Contactor Multiplex.

■ H5-05: Communication Fault Detection Selection

Enables or disables the CE detection for communications.

No.	Name	Setting Range	Default
H5-05	Communication Fault Detection Selection	0 or 1	1

Setting 0: Disabled

No communication error detection. The drive continues operation.

Setting 1: Enabled

If the drive does not receive data from the master for longer than the time set to H5-09, then a CE fault will be triggered and the drive will operate as determined by parameter H5-04.

■ H5-06: Drive Transmit Wait Time

Sets the time the drive waits after receiving data from a master until responding data.

Note: Cycle power for the setting to take effect.

No.	Name	Setting Range	Default
H5-06	Drive Transmit Wait Time	5 to 65 ms	5 ms

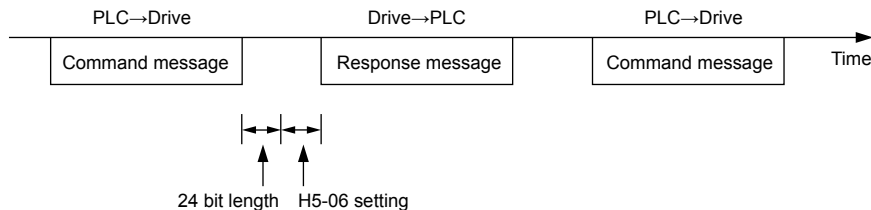

Figure C.5 Drive Transmit Wait Time Setting

■ H5-07: RTS Control Selection

Enables or disables RTS control.

Note: Cycle power for the setting to take effect.

No.	Name	Setting Range	Default
H5-07	RTS Control Selection	0 or 1	1

Setting 0: Disabled. RTS is always on.

Use this setting with point-to-point RS-422 communications.

Setting 1: Enabled. RTS switches while sending.

Use this setting with RS-485 communications or when using multi-drop RS-422 communications.

■ **H5-09: Communications Fault Detection Time**

Sets the time the communications must be lost before the drive triggers a CE fault.

No.	Name	Setting Range	Default
H5-09	Communications Fault Detection Time	0.0 to 10.0 s	2.0 s

■ **H5-10: Unit Selection for MEMOBUS/Modbus Register 0025H**

Sets the unit for the output voltage monitor value in MEMOBUS/Modbus register 0025H.

No.	Name	Setting Range	Default
H5-10	Unit Selection for MEMOBUS/Modbus Register 0025H	0 or 1	0

Setting 0: 0.1 V units

Setting 1: 1 V units

■ **H5-11: Communications Enter Function Selection**

Selects whether an Enter command is necessary to change parameter values via MEMOBUS/Modbus communications. *Refer to Enter Command on page 449.*

No.	Name	Setting Range	Default
H5-11	Communications Enter Function Selection	0 or 1	0

Setting 0: Enter command necessary

Parameter changes become effective after an Enter command. An Enter command must only be sent after the last parameter change, not for each single parameter.

Setting 1: Enter command not necessary

Parameter value changes become effective immediately without the need to send an Enter command.

■ **H5-12: Run Command Method Selection**

Selects the type of sequence used when the Run command source is set to MEMOBUS/Modbus communications (b1-02, b1-16 = 2).

No.	Name	Setting Range	Default
H5-12	Run Command Method Selection	0 or 1	0

Setting 0: FWD/Stop, REV/Stop

Setting bit 0 of MEMOBUS/Modbus register 0001H will start and stop the drive in the forward direction. Setting bit 1 will start and stop the drive in reverse.

Setting 1: Run/Stop, FWD/REV

Setting bit 0 of MEMOBUS/Modbus register 0001H will start and stop the drive. Setting bit 1 changes the direction.

■ **H5-14: Communication Error (CE) Go-To-Frequency**

Sets the speed at which the drive will run when H5-04 = 4 and a CE is present.

No.	Name	Setting Range	Default
H5-14	Communication Error (CE) Go-To-Frequency	0.0 to 400.0 Hz	0.0 Hz

■ **H5-15: Communication Error (CE) Go-To-Timeout**

Sets the time for which the drive will run at the speed set in H5-14 when H5-04 = 4 (Run at H5-14) before triggering a CE fault.

Setting this parameter to 0 will disable the timeout.

C.4 MEMOBUS/Modbus Setup Parameters

No.	Name	Setting Range	Default
H5-15	Communication Error (CE) Go-To-Timeout	0 to 6000 s	0 s

■ H5-16: Communication Error Fault Restart Selection

Determines whether the CE fault can be restarted.

No.	Name	Setting Range	Default
H5-16	Communication Error Fault Restart Selection	0 to 3	3

Setting 0: No retry

Setting 1: Retry

■ H5-17: Operation Selection when Unable to Write into EEPROM

Selects the operation to be carried out when attempting to write data into EEPROM by MEMOBUS/Modbus communications but writing into EEPROM is not enabled. There is normally no need to change this parameter from the default value.

No.	Name	Setting Range	Default
H5-17	Operation Selection when Unable to Write into EEPROM	0, 1	0

Setting 0: Cannot write into EEPROM

Setting 1: Write in RAM only

■ H5-18: Filter Time Constant for Motor Speed Monitoring

Sets the filter time constant for monitoring the motor speed from MEMOBUS/Modbus communications and communication options. Applicable MEMOBUS/Modbus registers are: 3EH, 3FH, 44H, ACH, and ADH

No.	Name	Setting Range	Default
H5-18	Filter Time Constant for Motor Speed Monitoring	0 to 100 ms	0 ms

C.5 Drive Operations by MEMOBUS/Modbus

The drive operations that can be performed by MEMOBUS/Modbus communication depend on drive parameter settings. This section explains the functions that can be used and related parameter settings.

◆ Observing the Drive Operation

PLCs can perform the following actions with MEMOBUS/Modbus communications:

- observe drive status and drive control terminal status
- read and write parameters (not H5-□□)
- reset faults
- set multi-function inputs

Note: Input settings from the input terminals (S1 to S8) and from MEMOBUS/Modbus communications are both linked by a logical OR operation.

◆ Controlling the Drive

Select an external reference and adjust the parameters in [Table C.2](#) accordingly to start and stop the drive or set the frequency reference using MEMOBUS/Modbus communications.

Table C.2 Setting Parameters for Drive Control from MEMOBUS/Modbus

Reference Source	Parameter	Name	Required Setting
External Reference 1	b1-01	Frequency Reference Selection 1	2
	b1-02	Run Command Selection 1	2
External Reference 2	b1-15	Frequency Reference Selection 2	2
	b1-16	Run Command Selection 2	2

Refer to b1-01: Frequency Reference Selection 1 on page 167 and Refer to b1-02: Run Command Selection 1 on page 170 for details on external reference parameter selections.

C.6 Communications Timing

To prevent a communications overrun in the slave drive, the master should wait a certain time between sending messages to the same drive. In the same way, the slave drive must wait before sending response messages to prevent an overrun in the master. This section explains the message timing.

◆ Command Messages from Master to Drive

The master must wait for a specified time between receiving a response and resending the same type of command to the same slave drive to prevent overrun and data loss. The minimum wait time depends on the command as shown in [Table C.3](#).

Table C.3 Minimum Wait Time for Sending Messages

Command Type	Example	Minimum Wait Time
1	<ul style="list-style-type: none"> Control command (Run, Stop) Set inputs/outputs Read monitors and parameter values 	5 ms </>
2	Write parameters	H5-11 = 0: 50 ms H5-11 = 1: 200 ms </>
3	Save changes using an Enter command	200 ms to 2 s, depending on the number of parameters that were changed </>
4	Enter with storage to drive EEPROM after initialization	5 s

<1> If the drive receives command type 1 data during the minimum wait time, it will perform the command and then respond. However, if it receives a command type 2 or 3 during that time, either a communication error will result or the command will be ignored.



Figure C.6 Minimum Wait Time for Sending Messages

Set a timer in the master to check how long it takes for the slave drive(s) to respond to the master. If no response is received within a certain amount of time, the master should try resending the message.

◆ Response Messages from Drive to Master

If the drive receives a command from the master, it will process the data received and wait for the time set in H5-06 until it responds. Increase H5-06 if the drive response causes overrun in the master.

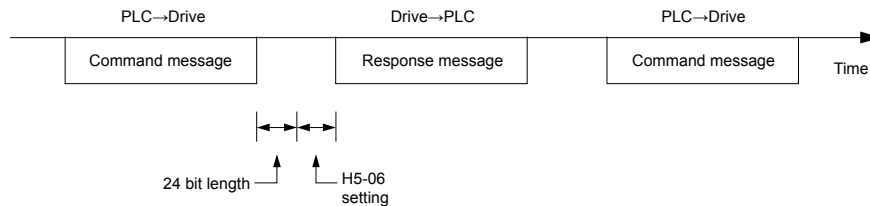

Figure C.7 Minimum Response Wait Time

C.7 Message Format

◆ Message Content

In MEMOBUS/Modbus communications, the master sends commands to the slave, and the slave responds. The message format is configured for both sending and receiving as shown below, and the length of data packets depends on the command (function) content.

SLAVE ADDRESS
FUNCTION CODE
DATA
ERROR CHECK

◆ Slave Address

The slave address in the message defines the note the message is sent to. Use addresses between 0 and FF (hex). If a message with slave address 0 is sent (broadcast), the command from the master will be received by all slaves. The slaves do not provide a response to a broadcast type message.

◆ Function Code

The three types of function codes are shown in the table below.

Function Code	Function Name	Data Length (bytes)			
		Command Message		Response Message	
		Minimum	Maximum	Minimum	Maximum
03H	Read MEMOBUS/Modbus registers	8	8	7	37
08H	Loopback test	8	8	8	8
10H	Write to multiple MEMOBUS/Modbus registers	11	41	8	8

◆ Data

Configure consecutive data by combining the MEMOBUS/Modbus register address (test code in case of a loopback test) and the data the register contains. The data length changes depending on the command details.

A drive MEMOBUS/Modbus register always has a data length of two bytes. Data written into drive registers must also always have a length of two bytes. Register data read out from the drive will always consist of two bytes.

◆ Error Check

The drive uses a CRC-16 (cyclic redundancy check, checksum method) for checking data validity. Use the procedure described below when calculating the CRC-16 checksum for command data or when verifying response data.

■ Command Data

When the drive receives data, it calculates the CRC-16 checksum from the data and compares it to the CRC-16 value received within the message. Both must match before a command is processed.

An initial value of FFFFH (i.e., all 16 bits equal 1) must be used for CRC-16 calculations in the MEMOBUS/Modbus protocol.

Calculate the CRC-16 checksum using the following steps:

1. The starting value is FFFFH.
2. Perform an XOR operation of this value and the slave address.
3. Right shift the result.
4. When the overflow bit of the shift operation becomes 1, perform an XOR operation of the result from step 3 above and the fix value A001H.
5. Repeat steps 3 and 4 until eight shift operations have been performed.
6. After eight shift operations, perform an XOR operation with the result and the next data in the message (function code, register address, data). Continue with steps 3 to 5 until the last data has been processed.
7. The result of the last shift or XOR operation is the checksum.

C.7 Message Format

The example in [Table C.4](#) shows the CRC-16 calculation of the slave address 02H and the function code 03H, yielding the result D140H.

Note: This example does not show the calculation for a complete MEMOBUS/Modbus command. Normally data would follow in the calculation.

Table C.4 CRC-16 Checksum Calculation Example

Description	Calculation	Overflow	Description	Calculation	Overflow
Initial Value (FFFFH)	1111 1111 1111 1111		Function Code 03H	0000 0000 0000 0011	
Address 02H	0000 0000 0000 0010		XOR w result	1000 0001 0011 1101	
XOR w initial value	1111 1111 1111 1101		Shift 1	0100 0000 1001 1110	1
Shift 1	0111 1111 1111 1110	1	XOR w A001H	1010 0000 0000 0001	
XOR w A001H	1010 0000 0000 0001		XOR result	1110 0000 1001 1111	
XOR result	1101 1111 1111 1111		Shift 2	0111 0000 0100 1111	1
Shift 2	0110 1111 1111 1111	1	XOR w A001H	1010 0000 0000 0001	
XOR w A001H	1010 0000 0000 0001		XOR result	1101 0000 0100 1110	
XOR result	1100 1111 1111 1110		Shift 3	0110 1000 0010 0111	0
Shift 3	0110 0111 1111 1111	0	Shift 4	0011 0100 0001 0011	1
Shift 4	0011 0011 1111 1111	1	XOR w A001H	1010 0000 0000 0001	
XOR w A001H	1010 0000 0000 0001		XOR result	1001 0100 0001 0010	
XOR result	1001 0011 1111 1110		Shift 5	0100 1010 0000 1001	0
Shift 5	0100 1001 1111 1111	0	Shift 6	0010 0101 0000 0100	1
Shift 6	0010 0100 1111 1111	1	XOR w A001H	1010 0000 0000 0001	
XOR w A001H	1010 0000 0000 0001		XOR result	1000 0101 0000 0101	
XOR result	1000 0100 1111 1110		Shift 7	0100 0010 1000 0010	1
Shift 7	0100 0010 0111 1111	0	XOR w A001H	1010 0000 0000 0001	
Shift 8	0010 0001 0011 1111	1	XOR result	1110 0010 1000 0011	
XOR w A001H	1010 0000 0000 0001		Shift 8	0111 0001 0100 0001	1
XOR result	1000 0001 0011 1110		XOR w A001H	1010 0000 0000 0001	
Perform operations with next data (function code)			XOR result	1101 0001 0100 0000	
			CRC-16	1101 0001 0100 0000	
				D 1 4 0 (Lower) (Upper)	
Continue from here with next data.					

■ Response Data

Perform a CRC-16 calculation on the response message data as described above as a validation check. The result should match the CRC-16 checksum received within the response message.

C.8 Message Examples

Below are some examples of command and response messages.

◆ Reading Drive MEMOBUS/Modbus Register Contents

Using the function code 03H (Read), a maximum of 16 MEMOBUS/Modbus registers can be read out at a time.

The following table shows message examples when reading status signals, error details, data link status, and frequency references from the slave 2 drive.

Command Message			Response Message (normal)			Response Message (fault)		
Slave Address		02H	Slave Address		02H	Slave Address		02H
Function Code		03H	Function Code		03H	Function Code		83H
Starting No.	Upper	00H	Data Quantity		08H	Error Code		03H
	Lower	20H	1st storage register	Upper	00H	CRC-16	Upper	F1H
Data Quantity	Upper	00H		Lower	65H		Lower	31H
	CRC-16	Lower	04H	Next storage register	Upper	00H		
Upper		45H	Lower		00H			
CRC-16	Lower	F0H	Next storage register	Upper	00H			
	Upper			Lower	00H			
CRC-16	Lower		Next storage register	Upper	01H			
	Upper			Lower	F4H			
CRC-16	Lower		CRC-16	Upper	AFH			
	Upper			Lower	82H			

◆ Loopback Test

Function code 08H performs a loopback test that returns a response message with exactly the same content as the command message. The response message can be used to check communications between the master and slave. User-defined test code and data values can also be set.

The following table shows a message example when performing a loopback test with the slave 1 drive.

Command Message			Response Message		
Slave Address		01H	Slave Address		01H
Function Code		08H	Function Code		08H
Test Code	Upper	00H	Test Code	Upper	00H
	Lower	00H		Lower	00H
Data	Upper	A5H	Data	Upper	A5H
	Lower	37H		Lower	37H
CRC-16	Upper	DAH	CRC-16	Upper	DAH
	Lower	8DH		Lower	8DH

◆ Writing to Multiple Registers

Function code 10H allows the user to write multiple drive MEMOBUS/Modbus registers with one message. This process works similar to reading registers, in that the address of the first register to be written and the data quantity are set in the command message. The data to be written must be consecutive so that the register addresses are in order, starting from the specified address in the command message. The data order must be high byte then lower byte.

The following table shows an example of a message where a forward operation has been set with a frequency reference of 60.00 Hz for the slave 1 drive.

If parameter values are changed using the Write command, an Enter command may be necessary to activate or save the data depending on the setting of H5-11. *Refer to H5-11: Communications Enter Function Selection on page 423* and *Refer to Enter Command on page 449* for detailed descriptions.

Command Message			Response Message (normal)			Response Message (fault)		
Slave Address		01H	Slave Address		01H	Slave Address		01H
Function Code		10H	Function Code		10H	Function Code		90H
Starting No.	Upper	00H	Starting No.	Upper	00H	Error Code		02H
	Lower	01H		Lower	01H	CRC-16	Upper	CDH
Data Quantity	Upper	00H	Data Quantity	Upper	00H		Lower	C1H
	Lower	02H		Lower	02H			
Number of Bytes		04H	CRC-16	Upper	10H			
Starting Data	Upper	00H		Lower	08H			
	Lower	01H						
Next Data	Upper	17H						
	Lower	70H						
CRC-16	Upper	63H						
	Lower	39H						

Note: Double the number of the data quantity for the number of bytes in the command message.

C.9 MEMOBUS/Modbus Data Table

The tables below list all MEMOBUS/Modbus data.

The MEMOBUS register hex addresses for parameters are listed beginning on page [321](#).

◆ Command Data

It is possible to both read and write command data.

Note: Bits that are not used should be set to 0. Refrain from writing to reserved registers.

Register No.	Contents		
0000H	Reserved		
0001H	Operation Commands and Multi-function Inputs		
	bit 0	H5-12 = 0: Forward Run Command (0 = Stop, 1 = Forward Run) H5-12 = 1: Run Command (0 = Stop, 1 = Run)	
	bit 1	H5-12 = 0: Reverse Run Command (0 = Stop, 1 = Reverse Run) H5-12 = 1: Forward/Reverse (0 = Forward, 1 = Reverse)	
	bit 2	Option Card External Fault (EF0)	
	bit 3	Fault Reset	
	bit 4	Multi-Function Input 1 Function is ComRef when H1-01 = 40 (Forward/Stop). Note: When the bit at ComCtrl is turned on, commands from MEMOBUS/Modbus communications take control of the operation. However, when a communications option card is connected, that option card is given priority.	
	bit 5	Multi-Function Input 2 Function is ComCtrl when H1-02 = 41 (Reverse/Stop).	
	bit 6	Multi-Function Input 3	
	bit 7	Multi-Function Input 4	
	bit 8	Multi-Function Input 5	
	bit 9	Multi-Function Input 6	
	bit A	Multi-Function Input 7	
	bit B	Multi-Function Input 8	
	bit C to F	Reserved	
0002H	Frequency Reference	Units are determined by parameter o1-03.	
0003H	Output voltage gain/ Unit: 0.1% Range: 20 (2.0%) to 2000 (200.0%), Default when power on: 1000 (100.0%)		
0004H	Torque Reference/Torque Limit, 0.1% units, signed (Usable only if Torque Control is enabled)		
0005H	Torque Compensation, 0.1% units, signed (Usable only if Torque Control is enabled)		
0006H	PID Target, 0.01% units, signed		
0007H	Analog Output Terminal FM Setting (10 V / 4000 H)		
0008H	Analog Output Terminal AM Setting (10 V / 4000 H)		
0009H	Settings for Multi-Function Digital Outputs		
	bit 0	Multi-Function Contact Output 1 (terminal M1-M2)	
	bit 1	Multi-Function Contact Output 2 (terminal M3-M4)	
	bit 2	Multi-Function Contact Output 3 (terminal MD-ME-MF)	
	bit 3 to 5	Reserved	
	bit 6	Enables the function in bit 7	
	bit 7	Fault Contact Output (terminal MA-MB-MC)	
bit 8 to F	Reserved		
000AH to 000EH	Reserved		

C.9 MEMOBUS/Modbus Data Table

Register No.	Contents	
000FH	Control Selection Setting	
	bit 0	Reserved
	bit 1	PID Setpoint Input
	bit 2	Torque reference / torque limit input (enables the setting from MEMOBUS/Modbus)
	bit 3	Torque compensation input (enables the setting from MEMOBUS/Modbus)
	bit 4 to B	Reserved
	bit C	Enable Terminal S5 Input for Broadcast Data
	bit D	Enable Terminal S6 Input for Broadcast Data
	bit E	Enable Terminal S7 Input for Broadcast Data
bit F	Enable Terminal S8 Input for Broadcast Data	
0010H to 001AH	Reserved	
001BH	Analog Monitor Option AO-A3 Analog Output 1 (10 V/4000 H)	
001CH	Analog Monitor Option AO-A3 Analog Output 2 (10 V/4000 H)	
001DH	Digital Output Option DO-A3 Output (Binary)	
001EH to 001FH	Reserved	
0A93H	bit 1	RTC Disable
	bit 2	Dynamic Noise Ctrl
3004H	Set Time – Hours/Minutes (HHmm)	
3005H	Set Date – Year/Day of Week (YYdd)	
3006H	Set Date – Month/Day (MMDD)	
3007H	RTC Set Command/Status	
	bit 0	Complete
	bit 1	Set RTC data using registers 3004H to 3006H
	bit 8	Failed
302FH	RTC Enter	
	bit 0	Overwrite RTC data using registers 3004H to 3006H. Only effective when 3030H (RTC Enter Enable) is set.
3030H	bit 1	RTC Enter Enable
	bit 2	RTC TIE Fault Enable

◆ Monitor Data

Monitor data can be read only.

Register No.	Contents	
0020H	Drive Status 1	
	bit 0	During Run
	bit 1	During Reverse
	bit 2	Drive Ready
	bit 3	Fault
	bit 4	Data Setting Error
	bit 5	Multi-Function Contact Output 1 (terminal M1-M2)
	bit 6	Multi-Function Contact Output 2 (terminal M3-M4)
	bit 7	Multi-Function Contact Output 3 (terminal MD-ME-MF)
	bit 8 to bit D	Reserved
	bit E	When ComRef has been enabled
	bit F	When ComCtrl has been enabled

Register No.	Contents	
0021H	Fault Contents 1	
	bit 0	Overcurrent (oC), Ground fault (GF)
	bit 1	Control Circuit Overvoltage (ov)
	bit 2	Overload (oL2)
	bit 3	Overheat 1 (oH1), Heatsink Overheat Warning (oH2)
	bit 4, 5	Reserved
	bit 6	PID Feedback Loss/Excessive PID Feedback (FbL / FbH)
	bit 7	EF to EF8: Pump Fault
	bit 8	CPF□□: Hardware Fault (includes oFx)
	bit 9	Motor Overload (oL1), Overtorque Detection 1/2 (oL3/oL4), Undertorque Detection 1/2 (UL3/UL4)
	bit A	Reserved
	bit B	Control Circuit Undervoltage (Uv), Power Supply Undervoltage (AUv), Power Supply Frequency Fault (Fdv)
	bit C	Control Circuit Undervoltage Fault (Uv1), Control Power Supply Voltage Fault (Uv2), Undervoltage 3 (Uv3), Power Supply Frequency Fault (Fdv), Power Supply Undervoltage (AUv), Phase Order Detection Fault (SrC)
	bit D	Output Phase Loss (LF)
bit E	MEMOBUS/Modbus Communication Error (CE), Option Communication Error (bUS)	
bit F	External Digital Operator Connection Fault (oPr)	
0022H	Data Link Status	
	bit 0	Writing data or switching motors
	bit 1, 2	Reserved
	bit 3	Upper or lower limit error
	bit 4	Data conformity error
	bit 5	Writing to EEPROM
	bit 6	0: Write into EEPROM. 1: Write in RAM only. Note: Enabled only when H5-17 = 1.
	bit 7 to bit F	Reserved
0023H	Frequency Reference </>	
0024H	Output Frequency </>	
0025H	Output Voltage Reference, 0.1 V units (units are determined by parameter H5-10)	
0026H	Output Current, 0.1 A units </>	
0027H	Output Power	
0028H	Torque Reference	
0029H	Fault Contents 2	
	bit 0	Reserved
	bit 1	Ground Fault (GF)
	bit 2	Reserved
	bit 3	Output Phase Loss (LF)
	bit 4, 5	Reserved
	bit 6	Motor Overheat 2 (PTC input) (oH4)
	bit 7 to bit F	Reserved



C.9 MEMOBUS/Modbus Data Table

Register No.	Contents	
002AH	Alarm Contents 1	
	bit 0, 1	Reserved
	bit 2	Forward/Reverse Run Command Input Error (EF)
	bit 3	Baseblock (bb)
	bit 4	Overtorque 1 (oL3)
	bit 5	Heatsink Overheat (oH)
	bit 6	Control Circuit Overvoltage (ov)
	bit 7	Control Circuit Undervoltage (Uv)
	bit 8	Fan Fault (FAn)
	bit 9	MEMOBUS/Modbus Communication Error (CE)
	bit A	Option Communication Error (bUS)
	bit B	Undertorque Detection 1/2 (UL3/UL4)
	bit C	Motor Overheat (oH3)
	bit D	PID Feedback Loss, Excessive PID Feedback (FbL, FbH)
	bit E	Reserved
bit F	Serial Communication Transmission Error (CALL)	
002BH	Input Terminal Status	
	bit 0	Terminal S1 Closed
	bit 1	Terminal S2 Closed
	bit 2	Terminal S3 Closed
	bit 3	Terminal S4 Closed
	bit 4	Terminal S5 Closed
	bit 5	Terminal S6 Closed
	bit 6	Terminal S7 Closed
	bit 7	Terminal S8 Closed
bit 8 to bit F	Reserved	
002CH	Drive Status 2	
	bit 0	During Run
	bit 1	Zero Speed
	bit 2	Speed Agree
	bit 3	User-set Speed Agree
	bit 4	Frequency Detection 1
	bit 5	Frequency Detection 2
	bit 6	Drive Ready
	bit 7	During Undervoltage
	bit 8	During Baseblock
	bit 9	Frequency Reference from Operator Keypad
	bit A	Run Command from Operator Keypad
	bit B	Over/Undertorque Detection 1, 2
	bit C	Frequency Reference Loss
	bit D	During Fault Restart
bit E	Fault	
bit F	Communication Timeout	
002DH	Output Terminal Status	
	bit 0	Multi-Function Contact Output 1 (terminal M1-M2)
	bit 1	Multi-Function Contact Output 2 (terminal M3-M4)
	bit 2	Multi-Function Contact Output 3 (terminal MD-ME-MF)
	bit 3 to 6	Reserved
	bit 7	Fault Contact Output (terminal MA/MB-MC)
bit 8 to F	Reserved	

Register No.	Contents		
002EH	Reserved		
002FH	Frequency Reference Bias (from Up/Down 2 Function), 0.1% units		
0030H	Reserved		
0031H	Control Circuit Voltage, 1 Vdc units		
0032H	Torque Reference (U1-09), 0.1% units		
0033H	Reserved		
0034H	Product Code 1 [ASCII], Product Type		
0035H	Product Code 2 [ASCII], Region Code		
0036H, 0037H	Reserved		
0038H	PID Feedback, 0.1% units, unsigned, 100% / maximum output frequency		
0039H	PID Input, 0.1% units, signed, 100% / maximum output frequency		
003AH	PID Output, 0.1% units, signed, 100% / maximum output frequency		
003BH, 003CH	Reserved		
003DH	Communications Error Contents <>		
	bit 0	CRC Error	
	bit 1	Data Length Error	
	bit 2	Reserved	
	bit 3	Parity Error	
	bit 4	Overflow Error	
	bit 5	Framing Error	
	bit 6	Timeout	
bit 7 to bit F	Reserved		
003EH	Output Frequency	r/min <4>	
003FH		0.01% units	
0040H to 004AH	Used for various monitors U1-□□.		
004BH	Drive status (U1-12)		
	bit 0	During Run	
	bit 1	During Zero Speed	
	bit 2	During Reverse Run	
	bit 3	During Fault Reset Signal Input	
	bit 4	During Speed Agree	
	bit 5	Drive Ready	
	bit 6	Alarm	
	bit 7	Fault	
	bit 8	During Operation Error (oPE□□)	
	bit 9	During Momentary Power Loss	
	bit A to B	Reserved	
	bit C	Auto Mode	
	bit D	Hand Mode	
bit E	ComRef status, NetRef status		
bit F	ComCtrl status		
004CH to 007EH	Used for monitors U1-□□, U4-□□, U5-□□ and U6-□□. <i>Refer to U2: Fault Trace on page 400</i> and <i>Refer to U3: Fault History on page 402</i> for parameter details.		
007FH	Alarm Code, <i>Refer to Alarm Register Contents on page 447</i> for Alarm codes.		
0080H to 0097H	Used for monitors U2-□□, U3-□□. <i>Refer to U: Monitors on page 397</i> for parameter details and <i>Refer to Fault Trace Contents on page 445</i> for register value descriptions.		
0098H, 0099H	U4-01 (Cumulative Operation Time) Example: When U4-01 (Cumulative Operation Time) is 12345 hours, then 0098H = 1234 and 0099H = 5.		
009AH, 009BH	U4-03 (Cooling Fan Operation Time) Example: When U4-03 (Cooling Fan Operation Time) is 12345 hours, then 009AH = 1234 and 009BH = 5.		
009CH to 00AAH	Reserved		

C.9 MEMOBUS/Modbus Data Table

Register No.	Contents	
00ABH	Drive Rated Current \leftrightarrow	
00ACH	Motor Speed (U1-05)	r/min units \leftrightarrow
00ADH		0.01% units
00AEH, 00AFH	Reserved	
00B0H	Option Code Connected to CN5-A	Register contains ASCII code of the option card. AO-A3 = 0004H Communication Option: Register contains ASCII code of first and third digit of the option card type number. Example: Register value is 5343H for "SC" if an SI-C3 option card is installed.
00B1H	Reserved	
00B2H	Option Code Connected to CN5-B	
00B3H	Option Code Connected to CN5-C	
00B4H	Reserved	
00B5H	Frequency Reference After Soft-starter (U1-16)	r/min units \leftrightarrow
00B6H		0.01% units
00B7H	Frequency Reference	r/min \leftrightarrow
00B8H		0.01% units
00B9H to 00BEH	Reserved	
00BFH	Lists the last two digits of operation error code oPE□□.	
00C0H	Fault Contents 3	
	bit 1	Control Circuit Undervoltage Fault (Uv1)
	bit 2	Control Power Supply Undervoltage Fault (Uv2)
	bit 3	Undervoltage 3 (Soft-Charge Bypass Circuit Fault) (Uv3)
	bit 4	Reserved
	bit 5	Ground Fault (GF)
	bit 6	Overcurrent (oC)
	bit 7	Control Circuit Overvoltage (ov)
	bit 8	Heatsink Overheat (oH)
	bit 9	Overheat 1 (oH1)
	bit A	Motor Overload (oL1)
	bit B	Overload (oL2)
	bit C	Overtorque Detection 1 (oL3)
	bit D	Overtorque Detection 2 (oL4)
bit E, F	Reserved	
00C1H	Fault Contents 4	
	bit 0	Pump Fault at input terminal S3 (EF3)
	bit 1	Pump Fault at input terminal S4 (EF4)
	bit 2	Pump Fault at input terminal S5 (EF5)
	bit 3	Pump Fault at input terminal S6 (EF6)
	bit 4	Pump Fault at input terminal S7 (EF7)
	bit 5	Pump Fault at input terminal S8 (EF8)
	bit 6	Fan Fault (FAn)
	bit 7 to A	Reserved
	bit B	Output Phase Loss (LF)
	bit C	Motor Overheat (PTC input) (oH3)
	bit D	External Digital Operator Connection Fault (oPr)
	bit E	EEPROM Write Error (Err)
bit F	Motor Overheat Fault (PTC input) (oH4)	

Register No.	Contents	
00C2H	Fault Contents 5	
	bit 0	MEMOBUS/Modbus Communication Error (CE)
	bit 1	Option Communication Error (bUS)
	bit 2, 3	Reserved
	bit 4	Control Fault (CF)
	bit 5	Reserved
	bit 6	Option Card External Fault (EF0)
	bit 7	PID Feedback Loss (FbL)
	bit 8	Undertorque Detection 1 (UL3)
	bit 9	Undertorque Detection 2 (UL4)
	bit A to E	Reserved
bit F	Hardware Fault (includes oFx)	
00C3H	Fault Contents 6	
	bit 0 to 4	Reserved
	bit 5	Output Current Imbalance (LF2)
	bit 6	Pull-Out Detection (STo)
	bit 7	Reserved
	bit 8	MECHATROLINK Watchdog Timer Error (E5)
	bit 9	Reserved
	bit A	Too Many Speed Search Restarts (SEr)
bit B to F	Reserved	
00C4H	Fault Contents 7	
	bit 0	PID Feedback Loss (FbH)
	bit 1	Pump Fault 1, input terminal S1 (EF1)
	bit 2	Pump Fault 2, input terminal S2 (EF2)
	bit 3, 4	Reserved
	bit 5	Current Offset Fault (CoF)
bit 6 to F	Reserved	
00C5H	Fault Contents 8	
	bit 0	LSo Fault (LSo)
	bit 1	Node Setup Fault (nSE)
	bit 2 to 8	Reserved
	bit 9	Underload Detection 6 (UL6)
	bit A, B	Reserved
	bit C	HOA Time Not Set (TIM)
	bit D	HOA Battery Low (bAT)
	bit E	HOA Time Data Error (TdE)
bit F	HOA Time Interval Error (TIE)	

C.9 MEMOBUS/Modbus Data Table

Register No.	Contents	
00C6H	Fault Contents 9	
	bit 0	Loss of Prime (LOP)
	bit 1	Low Flow (LOWFL)
	bit 2	Accum Level (ACCUM)
	bit 3	Low Feedback (LFB)
	bit 4	High Feedback (HFB)
	bit 5	Power Supply Undervoltage (AUv)
	bit 6	Power Supply Overvoltage (Aov)
	bit 7	Power Supply Frequency Fault Detection (Fdv)
	bit 8	Phase Order Detection Fault (SrC)
	bit 9	High Flow (HIFLO)
	bit A	Anti-Jam Fault (AJF)
	bit B	Low Water Level (LOWWL)
	bit C	Wire Break (FDBKL)
	bit D	Low Suction (LOSUC)
	bit E	Reserved
bit F	Low Water Level (LWL)	
00C7H	Fault Contents 10	
	bit 0	High Water Level (HWL)
	bit 1	High Suction (HISUC)
	bit 2	Water Level Loss (WLL)
	bit 3	SuctionPres Loss (SPL)
	bit 4	Volute-TStat Flt (VLTS)
	bit 5	Low PI Aux Level (LOAUX)
	bit 6	High PI Aux Level (HIAUX)
	bit 7	PI Aux Feedback Loss (AUXFB)
	bit 8	Differential Feedback Detected (DIFF)
	bit 9	Setpoint Not Met (NMS)
	bit A	Pump Over Cycle (POC)
	bit B to F	Reserved
00C8H	Alarm Contents 2	
	bit 0	Control Circuit Undervoltage (Uv)
	bit 1	Control Circuit Overvoltage (ov)
	bit 2	Heatsink Overheat (oH)
	bit 3	Heatsink Overheat Warning (oH2)
	bit 4	Overtorque Detection 1 (oL3)
	bit 5	Overtorque Detection 2 (oL4)
	bit 6	Forward/Reverse Run Commands Input Error (EF)
	bit 7	Baseblock (bb)
	bit 8	Pump Fault 3, input terminal S3 (EF3)
	bit 9	Pump Fault 4, input terminal S4 (EF4)
	bit A	Pump Fault 5, input terminal S5 (EF5)
	bit B	Pump Fault 6, input terminal S6 (EF6)
	bit C	Pump Fault 7, input terminal S7 (EF7)
	bit D	Pump Fault 8, input terminal S8 (EF8)
	bit E	Fan Fault (FAn)
bit F	Reserved	

Register No.	Contents	
00C9H	Alarm Contents 3	
	bit 0, 1	Reserved
	bit 2	External Digital Operator Connection Fault (oPr)
	bit 3	MEMOBUS/Modbus Communication Error (CE)
	bit 4	Option Communication Error (bUS)
	bit 5	Serial Communication Transmission Error (CALL)
	bit 6	Motor Overload (oL1)
	bit 7	Overload (oL2)
	bit 8	Reserved
	bit 9	Option Card External fault (EF0)
	bit A, B	Reserved
	bit C	Serial Communication Transmission Error (CALL)
	bit D	Undertorque Detection 1 (UL3)
	bit E	Undertorque Detection 2 (UL4)
bit F	MEMOBUS/Modbus Communication Test Mode Error (SE)	
00CAH	Alarm Contents 4	
	bit 0	Reserved
	bit 1	Motor Overheat Alarm (PTC Input) (oH3)
	bit 2 to 5	Reserved
	bit 6	PID Feedback Loss (FbL)
	bit 7	Excessive PID Feedback (FbH)
	bit 9	Drive Disabled (dnE)
bit A to F	Reserved	
00CBH	Alarm Contents 5	
	bit 0	SI-T3 Watchdog Error (E5)
	bit 1	SI-T3 Station Address Setting Error (AEr)
	bit 2	SI-T3 Comm. Cycle Setting Error (CyC)
	bit 3	High Current Alarm (HCA)
	bit 4	Cooling Fan Maintenance Time (LT-1)
	bit 5	Soft Charge Bypass Relay Maintenance Time (LT-2)
	bit 6	Damping Resistor Overheat (doH)
	bit 7	SI-S EEPROM Error (EEP)
	bit 8	Pump Fault 1 (input terminal S1) (EF1)
	bit 9	Pump Fault 2 (input terminal S2) (EF2)
bit A to F	Reserved	
00CCH	Alarm Contents 6	
	bit 0, 1	Reserved
	bit 2	Capacitor Maintenance Time (LT-3)
	bit 3, 4	Reserved
	bit 5	Low Flow (LOWFL)
	bit 6	Reserved
	bit 7	Motor Overheat (NTC Input) (oH5)
	bit 8	Reserved
	bit 9	High Flow (HIFLO)
	bit A	Low Suction (LOSUC)
	bit B	Loss Of Prime (LOP)
	bit C	Thermistor Disconnect (THo)
	bit D	Underload Detection 6 (UL6)
	bit E	Reserved
bit F	Power Supply Undervoltage (AuV)	

C.9 MEMOBUS/Modbus Data Table

Register No.	Contents	
00CDH	Alarm Contents 7	
	bit 0	Power Supply Frequency Fault Detection (Fdv)
	bit 1	Phase Order Detection Alarm (SrC)
	bit 2	Low Feedback Low FB Sensed
	bit 3	High Feedback High FB Sensed
	bit 4	Reserved
	bit 5	Freq. Ref < Pump Min P1-06
	bit 6	Freq. Ref < Thrust (P4-12)
	bit 7	Low City Pressure
	bit 8	Anti-Jam Active
	bit 9	Low Water Level (LOWWL)
	bit A	Reserved
	bit B	Feedback Loss Wire Break
	bit C	Reserved
	bit D	R-DNE-Sx : Remote Drv Dis
	bit E	Low Suction Pressure
bit F	Low Water in Tank	
00CEH	Alarm Contents 8	
	bit 0, 1	Reserved
	bit 2	Time Not Set (TIM)
	bit 3	Battery Low (bAT)
	bit 4	Time Deviation Error (TdE)
	bit 5	Setpoint Not Met (NMS)
	bit 6, 7	Reserved
	bit 8	Feedback Loss Go To B5-13
	bit 9, A	Reserved
	bit B	High Suction (HISUC)
	bit C	Water Lvl Loss (WLL)
	bit D	SuctionPres Loss (SPL)
	bit E	Snubber Discharge Resistor Overheat (SoH)
	bit F	ACCUM (Accum Lvl Reached)
00CFH	Alarm Contents 9	
	bit 0	Main Fdbk Lost, Using Backup FB
	bit 1	Backup Fdbk Lost, Check/Replace
	bit 2	Aux Fb Loss
	bit 3	Low Aux Level
	bit 4	High Aux Level
	bit 5	CE Comm Loss Go To H5-14
	bit 6	DIFF Detection
	bit 7, 8	Reserved
	bit 9	Pump Over Cycle
	bit A	De-scale Active
	bit B to F	Reserved

Register No.	Contents	
00D0H	CPF Contents 1	
	bit 0, 1	Reserved
	bit 2	Control Circuit Error (CPF02)
	bit 3	Control Circuit Error (CPF03)
	bit 4, 5	Reserved
	bit 6	Control Circuit Error (CPF06)
	bit 7	Control Circuit Error (CPF07)
	bit 8	Control Circuit Error (CPF08)
	bit 9, A	Reserved
	bit B	Control Circuit Error (CPF11)
	bit C	Control Circuit Error (CPF12)
	bit D	Control Circuit Error (CPF13)
	bit E	Control Circuit Error (CPF14)
	bit F	Reserved
00D1H	CPF Contents 2	
	bit 0	Control Circuit Error (CPF16)
	bit 1	Control Circuit Error (CPF17)
	bit 2	Control Circuit Error (CPF18)
	bit 3	Control Circuit Error (CPF19)
	bit 4	Control Circuit Error (CPF20)
	bit 5	Control Circuit Error (CPF21)
	bit 6	Control Circuit Error (CPF22)
	bit 7	Control Circuit Error (CPF23)
	bit 8	Control Circuit Error (CPF24)
	bit 9	Terminal Board not Connected (CPF25)
	bit A	Control Circuit Error (CPF26)
	bit B	Control Circuit Error (CPF27)
	bit C	Control Circuit Error (CPF28)
bit D	Control Circuit Error (CPF29)	
bit E	Control Circuit Error (CPF30)	
bit F	Control Circuit Error (CPF31)	
00D2H	CPF Contents 3	
	bit 0	Control Circuit Error (CPF32)
	bit 1	Control Circuit Error (CPF33)
	bit 2	Control Circuit Error (CPF34)
	bit 3	Control Circuit Error (CPF35)
	bit 4 to 7	Reserved
	bit 8	Control Circuit Error (CPF40)
	bit 9	Control Circuit Error (CPF41)
	bit A	Control Circuit Error (CPF42)
	bit B	Control Circuit Error (CPF43)
	bit C	Control Circuit Error (CPF44)
bit D	Control Circuit Error (CPF45)	
bit E, F	Reserved	
00D3H to 00D7H	Reserved	

C.9 MEMOBUS/Modbus Data Table

Register No.	Contents	
00D8H	oFA0□ Contents (CN5-A)	
	bit 0	Option Compatibility Error (oFA00)
	bit 1	Option not properly connected (oFA01)
	bit 2 to 4	Reserved
	bit 5	A/D Conversion Error (oFA05)
	bit 6	Option Response Error (oFA06)
	bit 7 to F	Reserved
00D9H	oFA1□ Contents (CN5-A)	
	bit 0	Option RAM Fault (oFA10)
	bit 1	Option Operation Mode Fault (SLMOD) (oFA11)
	bit 2	Unit Receive CRC Error (oFA12)
	bit 3	Unit Receive Frame Error (oFA13)
	bit 4	Unit Receive Abort Error (oFA14)
	bit 5	Option Receive CRC Error (oFA15)
	bit 6	Option Receive Frame Error (oFA16)
	bit 7	Option Receive Abort Error (oFA17)
bit 8 to F	Reserved	
00DAH to 00DBH	Reserved	
00DBH	oFA3□ Contents (CN5-A)	
	bit 0	Comm. ID Error (oFA30)
	bit 1	Model Code Error (oFA31)
	bit 2	Sumcheck Error (oFA32)
	bit 3	Comm. option timeout waiting for response (oFA33)
	bit 4	MEMOBUS Timeout (oFA34)
	bit 5	Unit timeout waiting for response (oFA35)
	bit 6	CI Check Error (oFA36)
	bit 7	Unit timeout waiting for response (oFA37)
	bit 8	Control Command Selection Error (oFA38)
	bit 9	Unit timeout waiting for response (oFA39)
	bit A	Control Response Selection 1 Error (oFA40)
	bit B	Unit timeout waiting for response (oFA41)
	bit C	Control Response Selection 2 Error (oFA42)
	bit D	Control Response Selection Error (oFA43)
bit E, F	Reserved	
00DCH	oFb0□ Contents (CN5-B)	
	bit 0	Option compatibility error (oFb00)
	bit 1	Option not properly connected (oFb01)
	bit 2	Same type of option card already connected (oFb02)
	bit 3, 4	Reserved
	bit 5	A/D Conversion Fault (oFb05)
	bit 6	Option Response Error (oFb06)
bit 7 to F	Reserved	

Register No.	Contents	
00DDH	oFb1□ Contents (CN5-B)	
	bit 0	Option RAM Fault (oFb10)
	bit 1	Option Operation Mode Fault (SLMOD) (oFb11)
	bit 2	Unit Receive CRC Error (oFb12)
	bit 3	Unit Receive Frame Error (oFb13)
	bit 4	Unit Receive Abort Error (oFb14)
	bit 5	Option Receive CRC Error (oFb15)
	bit 6	Option Receive Frame Error (oFb16)
	bit 7	Option Receive Abort Error (oFb17)
bit 8 to F	Reserved	
00DEH to 00DFH	Reserved	
00E0H	oFb3□ Contents (CN5-B)	
	bit 0	Comm. ID Error (oFb30)
	bit 1	Model Code Error (oFb31)
	bit 2	Sumcheck Error (oFb32)
	bit 3	Comm. option timeout waiting for response (oFb33)
	bit 4	MEMOBUS Timeout (oFb34)
	bit 5	Unit timeout waiting for response (oFb35)
	bit 6	CI Check Error (oFb36)
	bit 7	Unit timeout waiting for response (oFb37)
	bit 8	Control Command Selection Error (oFb38)
	bit 9	Unit timeout waiting for response (oFb39)
	bit A	Control Response Selection 1 Error (oFb40)
	bit B	Unit timeout waiting for response (oFb41)
	bit C	Control Response Selection 2 Error (oFb42)
	bit D	Control Response Selection Error (oFb43)
bit E, F	Reserved	
00E1H	oFC0□ Contents (CN5-C)	
	bit 0	Option compatibility error (oFC00)
	bit 1	Option not properly connected (oFC01)
	bit 2	Same type of option card already connected (oFC02)
	bit 3, 4	Reserved
	bit 5	A/D Conversion Fault (oFC05)
	bit 6	Option Response Error (oFC06)
	bit 7 to F	Reserved
00E2H	oFC1□ Contents (CN5-C)	
	bit 0	Option RAM Fault (oFC10)
	bit 1	Option Operation Mode Fault (SLMOD) (oFC11)
	bit 2	Unit Receive CRC Error (oFC12)
	bit 3	Unit Receive Frame Error (oFC13)
	bit 4	Unit Receive Abort Error (oFC14)
	bit 5	Option Receive CRC Error (oFC15)
	bit 6	Option Receive Frame Error (oFC16)
	bit 7	Option Receive Abort Error (oFC17)
bit 8 to F	Reserved	
00E3H	Reserved	

C.9 MEMOBUS/Modbus Data Table

Register No.	Contents	
00E4H	oFC5□ Contents (CN5-C)	
	bit 0	Encoder Option AD Conversion Error (oFC50)
	bit 1	Encoder Option Analog Circuit Error (oFC51)
	bit 2	Encoder Communication Timeout (oFC52)
	bit 3	Encoder Communication Data Error (oFC53)
	bit 4	Encoder Error (oFC54)
	bit 5	Resolver Error (oFC55)
	bit 6 to F	Reserved
00E5H to 00E9H	Reserved	
00EAH	Fault contents 11	
	bit 0 to 6	Reserved
	bit 7	Damping Resistor Overheat (doH)
	bit 8	Snubber Discharge Resistor Overheat (SoH)
	bit 9	Internal Resistance Fault (Srr)
	bit A to D	Reserved
	bit E	Safety Circuit Fault (SCF)
	bit F	Reserved
00EBH to 00FAH	Reserved	
00FBH	Output Current <2>	

- <1> Parameter o1-03, Digital Operator Display Selection, determines the units.
- <2> Display is in the following units:
 2□0028, 2□0042, and 4□0011 to 4□0027: 0.01 A units
 2□0054 to 2□0248 and 4□0034 to 4□0720: 0.1 A units
 4□0930: 1 A units
- <3> Communication error contents are saved until the fault is reset.
- <4> Set the number of motor poles to parameter E2-04 or E5-04 depending on the motor being used.

◆ Broadcast Messages

Data can be written from the master to all slave devices at the same time.

The slave address in a broadcast command message must be set to 00H. All slaves will receive the message, but will not respond.

Register No.	Contents	
0001H	Digital Input Command	
	bit 0	Forward Run (0: Stop 1: Run)
	bit 1	Direction Command (0: Forward, 1: Reverse)
	bit 2, 3	Reserved
	bit 4	External Fault
	bit 5	Fault Reset
	bit 6 to B	Reserved
	bit C	Multi-Function Digital Input S5
	bit D	Multi-Function Digital Input S6
	bit E	Multi-Function Digital Input S7
bit F	Multi-Function Digital Input S8	
0002H	Frequency Reference	30000/100%

◆ Fault Trace Contents

The table below shows the fault codes that can be read out by MEMOBUS/Modbus commands from the U2-□□ monitor parameters.

Table C.5 Fault Trace / History Register Contents

Fault Code	Fault Name	Fault Code	Fault Name
0002H	Control Circuit Undervoltage Fault (Uv1)	0025H	Control Fault (CF)
0003H	Control Power Supply Voltage Fault (Uv2)	0027H	Option Card External Fault (EF0)
0004H	Undervoltage 3 (Uv3)	0028H	PID Feedback Loss (FbL)
0006H	Ground Fault (GF)	0029H	Undertorque Detection 1 (UL3)
0007H	Overcurrent (oC)	002AH	Undertorque Detection 2 (UL4)
0008H	Control Circuit Overvoltage (ov)	0030H	Hardware Fault (including oFx)
0009H	Heatsink Overheat (oH)	0036H	Output Current Imbalance (LF2)
000AH	Overheat 1 (oH1)	0037H	Pull-Out Detection (Sto)
000BH	Motor Overload (oL1)	0039H	MECHATROLINK Watchdog Timer Error (E5)
000CH	Overload (oL2)	003BH	Too Many Speed Search Restarts (SEr)
000DH	Overtorque Detection 1 (oL3)	0041H	Excessive PID Feedback (FbH)
000EH	Overtorque Detection 2 (oL4)	0042H	Pump Fault 1, Input Terminal S1 (EF1)
0011H	Pump Fault at Input Terminal S3 (EF3)	0043H	Pump Fault 2, Input Terminal S2 (EF2)
0012H	Pump Fault at Input Terminal S4 (EF4)	0046H	Current Offset Fault (CoF)
0013H	Pump Fault at Input Terminal S5 (EF5)	004BH	Low Suction (LOSUC)
0014H	Pump Fault at Input Terminal S6 (EF6)	004CH	Loss Of Prime (LOP)
0015H	Pump Fault at Input Terminal S7 (EF7)	004EH	Underload Detection 6 (UL6)
0016H	Pump Fault at Input Terminal S8 (EF8)	0051H	LSO Fault (LSO)
0017H	Fan Fault (FAn)	0052H	Node Setup Fault (nSE)
0018H	Overspeed (oS)	005AH	Underload Detection 6 (UL6)
001CH	Output Phase Loss (LF)	005BH	Initial Polarity Estimation Timeout (dv7)
001DH	Motor Overheat Alarm (PTC input) (oH3)	005CH	Ground Fault (GF)
001EH	Digital Operator Connection Fault (oPr)	005DH	HOA Time Not Set (TIM)
001FH	EEPROM Write Error (Err)	005EH	HOA Battery Low (bAT)
0020H	Motor Overheat Fault (PTC input) (oH4)	005FH	HOA Time Deviation Error (TdE)
0021H	MEMOBUS/Modbus Communication Error (CE)	0060H	HOA Time Interval Error (TIE)
0022H	Option Communication Error (bUS)		

C.9 MEMOBUS/Modbus Data Table

Fault Code	Fault Name	Fault Code	Fault Name
0061H	Loss of Prime (LOP)	009EH	Control Circuit Error (CPF29)
0062H	Low Flow (LOWFL)	009FH	Control Circuit Error (CPF30)
0063H	Accum Level (ACCUM)	00A0H	Control Circuit Error (CPF31)
0064H	Low Feedback (LFB)	00A1H	Control Circuit Error (CPF32)
0065H	High Feedback (HFB)	00A2H	Control Circuit Error (CPF33)
0066H	Power Supply Undervoltage (AUv)	00A3H	Control Circuit Error (CPF34)
0067H	Power Supply Overvoltage (Aov)	00A4H	Control Circuit Error (CPF35)
0068H	Power Supply Frequency Fault Detection (Fdv)	00A9H	Control Circuit Error (CPF40)
0069H	Phase Order Detection Fault (SrC)	00AAH	Control Circuit Error (CPF41)
006AH	High Flow (HIFLO)	00ABH	Control Circuit Error (CPF42)
006BH	Anti-Jam Fault (AJF)	00ACH	Control Circuit Error (CPF43)
006CH	Low Water Level (LOWWL)	00ADH	Control Circuit Error (CPF44)
006DH	Wire Break (FDBKL)	00AEH	Control Circuit Error (CPF45)
006EH	Low Suction (LOSUC)	0101H	Option Compatibility Error (oFA00)
0070H	Low Water Level (LWL)	0102H	Option Not Properly Connected (oFA01)
0071H	High Water Level (HWL)	0106H	A/D Conversion Error (oFA05)
0072H	High Suction (HISUC)	0107H	Option Response Error (oFA06)
0073H	Water Level Loss (WLL)	0111H	Option RAM Fault (oFA10)
0074H	SuctionPres Loss (SPL)	0112H	Option Operation Mode Fault (SLMOD) (oFA11)
0075H	Volute-Thermostat Fault (VLTS)	0113H	Unit Receive CRC Error (oFA12)
0076H	Low PI Auxiliary Feedback Level (LOAUX)	0114H	Unit Receive Frame Error (oFA13)
0077H	High PI Auxiliary Feedback Level (HIAUX)	0115H	Unit Receive Abort Error (oFA14)
0078H	Wire-break detection for PI Aux Feedback Level (AUXFB)	0116H	Option Receive CRC Error (oFA15)
0079H	Differential Feedback Detected (DIFF)	0117H	Option Receive Frame Error (oFA16)
007AH	SetPoint Not Met (NMS)	0118H	Option Receive Abort Error (oFA17)
007BH	Pump Over Cycle Protection (POC)	0131H	Comm. ID Error (oFA30)
0081H	Control Circuit Error (CPF00)	0132H	Model Code Error (oFA31)
0082H	Control Circuit Error (CPF01)	0133H	Sumcheck Error (oFA32)
0083H	Control Circuit Error (CPF02)	0134H	Comm. Option Timeout Waiting for Response (oFA33)
0084H	Control Circuit Error (CPF03)	0135H	MEMOBUS Timeout (oFA34)
0087H	Control Circuit Error (CPF06)	0136H	Unit Timeout Waiting for Response (oFA35)
0088H	Control Circuit Error (CPF07)	0137H	CI Check Error (oFA36)
0089H	Control Circuit Error (CPF08)	0138H	Unit Timeout Waiting for Response (oFA37)
008CH	Control Circuit Error (CPF11)	0139H	Control Command Selection Error (oFA38)
008DH	Control Circuit Error (CPF12)	013AH	Unit Timeout Waiting for Response (oFA39)
008EH	Control Circuit Error (CPF13)	013BH	Control Response Selection 1 Error (oFA40)
008FH	Control Circuit Error (CPF14)	013CH	Unit Timeout Waiting for Response (oFA41)
0091H	Control Circuit Error (CPF16)	013DH	Control Response Selection 2 Error (oFA42)
0092H	Control Circuit Error (CPF17)	013EH	Control Response Selection Error (oFA43)
0093H	Control Circuit Error (CPF18)	0201H	Option Compatibility Error (oFB00)
0094H	Control Circuit Error (CPF19)	0202H	Option Connection Error (oFb01)
0095H	Control Circuit Error (CPF20)	0203H	Same Type of Option Card Already Connected (oFb02)
0096H	Control Circuit Error (CPF21)	0206H	A/D Conversion Error (oFb05)
0097H	Control Circuit Error (CPF22)	0207H	Option Response Error (oFb06)
0098H	Control Circuit Error (CPF23)	0211H	Option RAM Fault (oFb10)
0099H	Control Circuit Error (CPF24)	0212H	Option Operation Mode Fault (SLMOD) (oFb11)
009AH	Terminal Board not Connected (CPF25)	0213H	Unit Receive CRC Error (oFb12)
009BH	Control Circuit Error (CPF26)	0214H	Unit Receive Frame Error (oFb13)
009CH	Control Circuit Error (CPF27)	0215H	Unit Receive Abort Error (oFb14)
009DH	Control Circuit Error (CPF28)		

Fault Code	Fault Name
0216H	Option Receive CRC Error (oFb15)
0217H	Option Receive Frame Error (oFb16)
0218H	Option Receive Abort Error (oFb17)
0232H	Model Code Error (oFb31)
0233H	Sumcheck Error (oFb32)
0234H	Comm. option Timeout Waiting for Response (oFb33)
0235H	MEMOBUS Timeout (oFb34)
0236H	Unit Timeout Waiting for Response (oFb35)
0237H	CI Check Error (oFb36)
0238H	Unit Timeout Waiting for Response (oFb37)
0239H	Control Command Selection Error (oFb38)
023AH	Unit Timeout Waiting for Response (oFb39)
023BH	Control Response Selection 1 Error (oFb40)
023CH	Unit Timeout Waiting for Response (oFb41)
023DH	Control Response Selection 2 Error (oFb42)
023EH	Control Response Selection Error (oFb43)
0301H	Option Compatibility Error (oFC00)
0303H	Option Not Properly Connected (oFC01)
0304H	Same Type of Option Card Already Connected (oFC02)

Fault Code	Fault Name
0306H	A/D Conversion Error (oFC05)
0307H	Option Response Error (oFC06)
0311H	Option RAM Fault (oFC10)
0312H	Option Operation Mode Fault (SLMOD) (oFC11)
0313H	Unit Receive CRC Error (oFC12)
0314H	Unit Receive Frame Error (oFC13)
0315H	Unit Receive Abort Error (oFC14)
0316H	Option Receive CRC Error (oFC15)
0317H	Option Receive Frame Error (oFC16)
0318H	Option Receive Abort Error (oFC17)
0351H	Encoder Option AD Conversion Error (oFC50)
0352H	Encoder Option Analog Circuit Error (oFC51)
0353H	Encoder Communication Timeout (oFC52)
0354H	Encoder Communication Data Error (oFC53)
0355H	Encoder Error (oFC54)
0356H	Resolver Error (oFC55)
0408H	Damping Resistor Overheat (doH)
0409H	Snubber Discharge Resistor Overheat (SoH)
040AH	Internal Resistance Fault (Srr)

◆ Alarm Register Contents

The table below shows the alarm codes that can be read out from MEMOBUS/Modbus register 007FH.

Table C.6 Alarm Register 007FH Contents

Fault Code	Fault Name
0001H	Control Circuit Undervoltage (Uv)
0002H	Control Circuit Overvoltage (ov)
0003H	Heatsink Overheat (oH)
0004H	Heatsink Overheat Warning (oH2)
0005H	Overtorque 1 (oL3)
0006H	Overtorque 2 (oL4)
0007H	Forward/Reverse Run commands input error (EF)
0008H	Baseblock (bb)
0009H	Pump Fault 3, input terminal S3 (EF3)
000AH	Pump Fault 4, input terminal S4 (EF4)
000BH	Pump Fault 5, input terminal S5 (EF5)
000CH	Pump Fault 6, input terminal S6 (EF6)
000DH	Pump Fault 7, input terminal S7 (EF7)
000EH	Pump Fault 8, input terminal S8 (EF8)
000FH	Fan Fault (FAn)
0014H	MEMOBUS/Modbus Communication Error (CE)
0015H	Option Communication Error (bUS)
0016H	Serial Communication Transmission Error (CALL)
001AH	Option Card External Fault (EF0)
001DH	Serial Communication Transmission Error (CALL)
001EH	Undertorque Detection 1 (UL3)
001FH	Undertorque Detection 2 (UL4)
0020H	MEMOBUS/Modbus Communication Test Mode Error (SE)
0022H	Motor Overheat (oH3)

Fault Code	Fault Name
0027H	PID Feedback Loss (FbL)
0028H	Excessive PID Feedback (FbH)
002AH	Drive Disabled (dnE)
0031H	MECHATROLINK Watchdog Timer Error (E5)
0032H	Station Address Setting Error (AEr)
0033H	MECHATROLINK Comm. Cycle Setting Error (CyC)
0034H	Current Alarm (HCA)
0035H	Cooling Fan Maintenance Time (LT-1)
0036H	Capacitor Maintenance Time (LT-2)
0037H	Damping Resistor Overheat (doH)
0038H	SI-S EEPROM Error (EEP)
0039H	Pump Fault (input terminal S1) (EF1)
003AH	Pump Fault (input terminal S2) (EF2)
0043H	Soft Charge Bypass Relay Maintenance Time (LT-3)
0045H	Accumulated Level (ACCUM)
0046H	Low Flow (LOWFL)
004AH	High Flow (HIFLO)
004BH	Low Suction (LOSUC)
004CH	Loss of Prime (LOP)
004EH	Underload Detection 6 (UL6)
0050H	Power Supply Undervoltage (AUv)
0053H	Low Feedback Low FB Sensed
0054H	High Feedback High FB Sensed
0056H	Freq. Ref Pump Min (P1-06)

C.9 MEMOBUS/Modbus Data Table

Fault Code	Fault Name
0057H	Freq. Ref Thrust (P4-12)
0058H	Low City Pressure
0059H	Anti Jam Active
005AH	Low Water Level (LOWWL)
005CH	Feedback Loss Wire Break
005EH	R-DNE-Sx Remote Drv Dis
005FH	Low Suction Pressure
0060H	Low Water in Tank
0063H	Clock Not Set (TIM)
0064H	HOA Battery Low (bAT)
0065H	HOA Time Deviation Error (TdE)
0066H	Setpoint Not Met (NMS)
0069H	Feedback Loss Go To Freq b5-13
006CH	High Suction (HISUC)

Fault Code	Fault Name
006DH	Water Level Loss (WLL)
006EH	SuctionPres Loss (SPL)
0070H	Flow Accumulation level reached (Accum Lvl Reached)
0071H	Main Feedback Lost (Main FdBk Lost)
0072H	Back-up Feedback Lost (Backup FdBk Lost)
0073H	Wire-break detection for PI Aux Feedback Level
0074H	Low PI Auxiliary Feedback Level
0075H	High PI Auxiliary Feedback Level
0076H	CE-Comm LossRun at H5-14
0077H	Differential Detected (DIFF)
007AH	Pump Cycling - Pump Over Cycle
007BH	De-Scale/De-rag Active

C.10 Enter Command

When writing parameters to the drive from the PLC using MEMOBUS/Modbus communication, parameter H5-11 determines whether an Enter command must be issued to enable these parameters. This section describes the types and functions of the Enter commands.

◆ Enter Command Types

The drive supports two types of Enter commands as shown in [Table C.7](#). An Enter command is enabled by writing 0 to register numbers 0900H or 0910H. It is only possible to write to these registers; attempting to read from these registers will cause an error.

Table C.7 Enter Command Types

Register No.	Description
0900H	Simultaneously writes data into the EEPROM (non-volatile memory) of the drive and enables the data in RAM. Parameter changes remain after cycling power.
0910H	Writes data in the RAM only. Parameter changes are lost when the drive is shut off.

Note: The EEPROM can only be written to 100,000 times, so it is recommended to limit the number of times writing to the EEPROM. The Enter command registers are write-only and if these registers are read, the register address will be invalid (Error code: 02H). An Enter command is not required when reference or broadcast data are sent to the drive.

C.11 Communication Errors

◆ MEMOBUS/Modbus Error Codes

A list of MEMOBUS/Modbus errors appears below.

When an error occurs, remove whatever caused the error and restart communications.

Error Code	Error Name
	Cause
01H	Function Code Error
	Attempted to set a function code from a PLC other than 03H, 08H, and 10H.
02H	Register Number Error
	<ul style="list-style-type: none"> • A register number specified in the command message does not exist. • Attempted to send a broadcast message using other register numbers than 0001H or 0002H.
03H	Bit Count Error
	<ul style="list-style-type: none"> • Read data or write data is greater than 16 bits. Invalid command message quantity. • In a write message, the “Number of Data Items” contained within the message does not equal twice the amount of data words (i.e., the total of Data 1+ Data 2, etc.).
21H	Data Setting Error
	<ul style="list-style-type: none"> • Control data or parameter write data is outside the allowable setting range. • Attempted to write a contradictory parameter setting.
22H	Write Mode Error
	<ul style="list-style-type: none"> • During run, the user attempted to write a parameter that cannot be written to during run. • During a control circuit error (CPF06), the master attempted to write to a parameter other than A1-00 to A1-05, E1-03, or o2-04. • Attempted to write to read-only data.
23H	Power Supply Err Write Error
	During an undervoltage situation, the master attempted to write to parameters that cannot be written to during undervoltage.
24H	Write Error During Parameter Process
	Master attempted writing to the drive while the unit was processing parameter data.
25H	Writing into EEPROM Disabled
	An attempt was made to write data into EEPROM by MEMOBUS/Modbus communications when writing EEPROM is not possible. (When this error code occurs, an error message is displayed and the drive continues operation.)

◆ Slave Not Responding

In the following situations, the slave drive will ignore the command message sent from the master, and not send a response message:

- When a communications error (overrun, framing, parity, or CRC-16) is detected in the command message.
- When the slave address in the command message and the slave address in the unit do not match (remember to set the slave address for the drive using H5-01).
- When the gap between two blocks (8-bit) of a message exceeds 24 bits.
- When the command message data length is invalid.

Note: If the slave address specified in the command message is 00H, all slaves execute the write function, but do not return response messages to the master.

C.12 Self-Diagnostics

The drive has a built-in self-diagnosing function of the serial communication interface circuits. To perform the self-diagnosis function, use the following procedure.

DANGER! Electrical Shock Hazard. Do not connect or disconnect wiring while the power is on. Failure to comply will result in death or serious injury. Before servicing, disconnect all power to the equipment. The capacitor for the control power supply remains charged even after the power supply is turned off. The charge indicator LED will extinguish when the control power supply voltage is below 50 Vdc. To prevent electric shock, wait at least one minute after all indicators are OFF and measure the control power supply voltage level to confirm safe level.

1. Turn on the power to the drive.
2. Note the present terminal S6 function selection setting (H1-06) and set it for the communications test mode (H1-06 = 67).
3. Turn off the power to the drive.
4. With the power off, wire the drive as shown in [Figure C.8](#), connecting terminals R+ and S+, R- and S-, and S6 and SC.

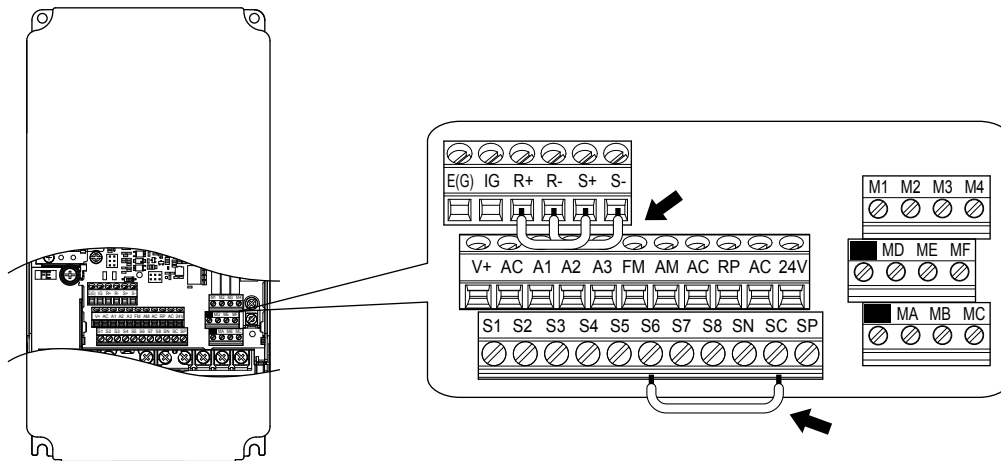

Figure C.8 Terminal Connections for Communication Self-Diagnostics

5. Verify that terminals SC to SP are connected by wire jumper.
6. Turn the power to the drive back on.
7. During normal operation, the drive will display "PASS" to indicate that the communications test mode is operating normally.
When a fault occurs, the drive will display "CE" on the keypad display.
8. Turn off the power supply.
9. Remove the wire jumpers from terminal R+, R-, S+, S-, and S6 to SC. Reset jumper SC to SP to its original position and set terminal S6 to its original function.
10. Return to normal operation.

This Page Intentionally Blank

Appendix: D

Standards Compliance

This appendix explains the guidelines and criteria for maintaining CE and UL standards.

D.1	SECTION SAFETY	454
D.2	UL STANDARDS	456

D.1 Section Safety

DANGER

Electrical Shock Hazard

Before servicing, disconnect all power to the equipment.

The capacitor for the control power supply remains charged even after the power supply is turned off. The charge indicator LED will extinguish when the control power supply voltage is below 50 Vdc. To prevent electric shock, wait for at least the time specified on the warning label, once all indicators are OFF, measure for unsafe voltages to confirm the drive is safe prior to servicing.

Failure to comply will result in death or serious injury.

WARNING

Electrical Shock Hazard

Do not operate equipment with covers removed.

Failure to comply could result in death or serious injury.

The diagrams in this section may show drives without covers or safety shields to show details. Be sure to reinstall covers or shields before operating the drives and run the drives according to the instructions described in this manual.

Always ground the motor-side grounding terminal.

Improper equipment grounding could result in death or serious injury by contacting the motor case.

Do not touch any terminals before the capacitors have fully discharged.

Failure to comply could result in death or serious injury.

Before wiring terminals, disconnect all power to the equipment. The capacitor for the control power supply remains charged even after the power supply is turned off. After shutting off the power, wait for at least the amount of time specified on the drive before touching any components.

Do not allow unqualified personnel to perform work on the drive.

Failure to comply could result in death or serious injury.

Installation, maintenance, inspection, and service must be performed only by authorized personnel familiar installation, adjustment, and maintenance of drives.

Do not perform work on the drive while wearing loose clothing, jewelry or without eye protection.

Failure to comply could result in death or serious injury.

Remove all metal objects such as watches and rings, secure loose clothing, and wear eye protection before beginning work on the drive.

Do not remove covers or touch circuit boards while the power is on.

Failure to comply could result in death or serious injury.

Fire Hazard

Tighten all terminal screws to the specified tightening torque.

Loose electrical connections could result in death or serious injury by fire due to overheating of electrical connections.

Do not use an improper voltage source.

Failure to comply could result in death or serious injury by fire.

Verify that the rated voltage of the drive matches the voltage of the incoming power supply before applying power.

Do not use improper combustible materials for the drive and harmonic filter module.

Failure to comply could result in death or serious injury by fire.

Attach the drive and harmonic filter module to metal or other noncombustible material.

NOTICE

Observe proper electrostatic discharge procedures (ESD) when handling the drive and circuit boards.

Failure to comply may result in ESD damage to the drive circuitry.

Never connect or disconnect the motor from the drive while the drive is outputting voltage.

Improper equipment sequencing could result in damage to the drive.

Do not use unshielded wire for control wiring.

Failure to comply may cause electrical interference resulting in poor system performance. Use shielded twisted-pair wires and ground the shield to the ground terminal of the drive.

Do not modify the drive circuitry.

Failure to comply could result in damage to the drive and will void warranty.

Yaskawa is not responsible for modification of the product made by the user. This product must not be modified.

Check all the wiring to ensure that all connections are correct after installing the drive and connecting other devices.

Failure to comply could result in damage to the drive.

If a fuse is blown or a Ground Fault Circuit Interrupter (GFCI) is tripped, check the wiring and the selection of the peripheral devices.

Contact your supplier if the cause cannot be identified after checking the above.

Do not restart the drive immediately operate the peripheral devices if a fuse is blown or a GFCI is tripped.

Check the wiring and the selection of peripheral devices to identify the cause. Contact your supplier before restarting the drive or the peripheral devices if the cause cannot be identified.

D.2 UL Standards

◆ UL Standards Compliance



Figure D.1 UL/cUL Mark

The UL/cUL mark applies to products in the United States and Canada. It indicates that UL has performed product testing and evaluation, and determined that their stringent standards for product safety have been met. For a product to receive UL certification, all components inside that product must also receive UL certification.

This drive is tested in accordance with UL standard UL 61800-5-1 and complies with UL requirements. The conditions described below must be met to maintain compliance when using this drive in combination with other equipment:

■ Conditions of Acceptability

- Install the Three-Phase Harmonics Filter Module on the input side of drive models 4□0720 to 4□0930. Refer to [Table D.1](#) for details.

Table D.1 Correspondence of Harmonic Filter Module and Drive Models 4□0720 to 4□0930

Drive Model	Harmonic Filter Module
4□0720	EUJ71180□.□
4□0930	EUJ71182□.□

- Install the drive and peripherals in a suitable enclosure for end use.

■ Installation Area

Do not install the drive to an area greater than pollution degree 2 (UL standard).

■ Ambient Temperature

IP00/Open Type Enclosure: -10 °C to +50 °C (14 °F to 122 °F)

IP20/UL Type 1 Enclosure: -10 to +40 °C (14 °F to 104 °F)

Finless Type: IP20/IP00 Enclosure: -10 to +45 °C (14 °F to 113 °F)

■ Main Circuit Terminal Wiring

Yaskawa recommends using closed-loop crimp terminals on all drive models. Use only the tools recommended by the terminal manufacturer for crimping. [Refer to Closed-Loop Crimp Terminal Recommendations on page 462](#) for closed-loop crimp terminal recommendations.

The wire gauges listed in the following tables are Yaskawa recommendations. Refer to local codes for proper wire gauge selections.

- Note:** The ⊕ mark indicates the terminals for protective ground connection.
 Grounding impedance:
 200 V: 100 Ω or less
 400 V: 10 Ω or less

■ Three-Phase 200 V Class Drives

Table D.2 Drive Wire Gauge and Torque Specifications (Three-Phase 200 V Class)

Drive Model	Terminal	For USA and Canada		For South America		Screw Size	Tightening Torque N·m (lb.in.)
		Recomm. Gauge mm ² (AWG, kcmil)	Applicable Gauge mm ² (AWG, kcmil)	Recomm. Gauge mm ² (AWG, kcmil)	Applicable Gauge mm ² (AWG, kcmil)		
2□0028	R/L1, S/L2, T/L3	10 (8)	6 to 10 (10 to 8)	4 (12)	2.5 to 10 (14 to 8)	M5	2.3 to 2.7 (20.4 to 23.9)
	U/T1, V/T2, W/T3	10 (8)	6 to 10 (10 to 8)	4 (12)	2.5 to 10 (14 to 8)	M5	
	⊖	10 (8)	6 to 16 (10 to 6)	6 (10)	6 to 16 (10 to 5)	M6	3.9 to 4.9 (34.7 to 43.4)
	p1, n1	2.5 (14)	2.5 to 4 (14 to 12)	2.5 (14)	2.5 to 4 (14 to 12)	M4	1 to 1.4 (8.9 to 12.4)
2□0042	R/L1, S/L2, T/L3	16 (6)	10 to 25 (8 to 3)	10 (8)	6 to 25 (10 to 3)	M6	4 to 6 (35.4 to 53.1)
	U/T1, V/T2, W/T3	16 (6)	10 to 25 (8 to 3)	10 (8)	6 to 25 (10 to 3)	M6	
	⊖	10 (8)	6 to 25 (10 to 3)	10 (8)	6 to 25 (10 to 3)	M8	8.8 to 10.8 (78.1 to 95.5)
	p1, n1	2.5 (14)	2.5 to 4 (14 to 12)	2.5 (14)	2.5 to 4 (14 to 12)	M4	1 to 1.4 (8.9 to 12.4)
2□0054	R/L1, S/L2, T/L3	25 (4)	16 to 25 (6 to 3)	16 (5)	10 to 25 (8 to 3)	M6	4 to 6 (35.4 to 53.1)
	U/T1, V/T2, W/T3	25 (4)	16 to 25 (6 to 3)	16 (5)	10 to 25 (8 to 3)	M6	
	⊖	16 (6)	10 to 25 (8 to 3)	10 (8)	10 to 25 (8 to 3)	M8	8.8 to 10.8 (78.1 to 95.5)
	p1, n1	2.5 (14)	2.5 to 4 (14 to 12)	2.5 (14)	2.5 to 4 (14 to 12)	M4	1 to 1.4 (8.9 to 12.4)
2□0068	R/L1, S/L2, T/L3	25 (4)	25 (4 to 3)	16 (5)	16 to 25 (5 to 3)	M6	4 to 6 (35.4 to 53.1)
	U/T1, V/T2, W/T3	25 (4)	25 (4 to 3)	16 (5)	16 to 25 (5 to 3)	M6	
	⊖	16 (6)	16 to 25 (6 to 3)	16 (5)	16 to 25 (5 to 3)	M8	8.8 to 10.8 (78.1 to 95.5)
	p1, n1	2.5 (14)	2.5 to 4 (14 to 12)	2.5 (14)	2.5 to 4 (14 to 12)	M4	1 to 1.4 (8.9 to 12.4)
2□0081	R/L1, S/L2, T/L3	16 × 2 (6 × 2P)	16 to 25 × 2 (6 to 3 × 2P)	25 (3)	16 to 25 (5 to 3 × 2P)	M6	4 to 6 (35.4 to 53.1)
	U/T1, V/T2, W/T3	16 × 2 (6 × 2P)	16 to 25 × 2 (6 to 3 × 2P)	25 (3)	16 to 25 (5 to 3 × 2P)	M6	
	⊖	16 (6)	16 to 25 (6 to 3)	16 (5)	16 to 25 (5 to 3)	M8	8.8 to 10.8 (78.1 to 95.5)
	p1, n1	2.5 (14)	2.5 to 4 (14 to 12)	2.5 (14)	2.5 to 4 (14 to 12)	M4	1 to 1.4 (8.9 to 12.4)
2□0104	R/L1, S/L2, T/L3	35 (1)	16 to 50 × 2 (6 to 1/0 × 2P)	35 (1)	10 to 50 × 2P (8 to 1/0 × 2P)	M8	8 to 10 (70.8 to 88.5)
	U/T1, V/T2, W/T3	35 (1)	16 to 50 × 2 (6 to 1/0 × 2P)	35 (1)	10 to 50 × 2P (8 to 1/0 × 2P)	M8	
	⊖	25 (4)	25 to 35 (4 to 1)	25 (3)	10 to 35 (8 to 1)	M8	8.8 to 10.8 (78.1 to 95.5)
	p1, n1	2.5 (14)	2.5 to 4 (14 to 12)	2.5 (14)	2.5 to 4 (14 to 12)	M4	1.2 to 2.0 (10.4 to 17.4)

D.2 UL Standards

Drive Model	Terminal	For USA and Canada		For South America		Screw Size	Tightening Torque N·m (lb.in.)
		Recomm. Gauge mm ² (AWG, kcmil)	Applicable Gauge mm ² (AWG, kcmil)	Recomm. Gauge mm ² (AWG, kcmil)	Applicable Gauge mm ² (AWG, kcmil)		
2□0130	R/L1, S/L2, T/L3	25 × 2 (4 × 2P)	16 to 50 × 2 (6 to 1/0 × 2P)	16 × 2P (5 × 2P)	10 to 50 × 2P (8 to 1/0 × 2P)	M8	8 to 10 (70.8 to 88.5)
	U/T1, V/T2, W/T3	25 × 2 (4 × 2P)	16 to 50 × 2 (6 to 1/0 × 2P)	16 × 2P (5 × 2P)	10 to 50 × 2P (8 to 1/0 × 2P)	M8	
	⊕	25 (4)	25 to 35 (4 to 1)	16 (5)	16 to 35 (5 to 1)	M8	8.8 to 10.8 (78.1 to 95.5)
	p1, n1	2.5 (14)	2.5 to 4 (14 to 12)	2.5 (14)	2.5 to 4 (14 to 12)	M4	1.2 to 2.0 (10.4 to 17.4)
2□0154	R/L1, S/L2, T/L3	25 × 2 (3 × 2P)	25 to 95 × 2 (4 to 4/0 × 2P)	25 × 2P (3 × 2P)	16 to 95 × 2P (5 to 4/0 × 2P)	M10	15 to 20 (130 to 173)
	U/T1, V/T2, W/T3	25 × 2 (3 × 2P)	25 to 95 × 2 (4 to 4/0 × 2P)	25 × 2P (3 × 2P)	16 to 95 × 2P (5 to 4/0 × 2P)	M10	
	⊕	25 (4)	25 to 70 (4 to 2/0)	25 (3)	25 to 70 (3 to 2/0)	M10	17.7 to 22.6 (156 to 200)
	p1, n1	2.5 (14)	2.5 to 4 (14 to 12)	2.5 (14)	2.5 to 4 (14 to 12)	M4	1.2 to 2.0 (10.4 to 17.4)
2□0192	R/L1, S/L2, T/L3	35 × 2 (1 × 2P)	25 to 95 × 2 (3 to 4/0 × 2P)	35 × 2P (1 × 2P)	25 to 95 × 2P (3 to 4/0 × 2P)	M10	15 to 20 (130 to 173)
	U/T1, V/T2, W/T3	35 × 2 (1 × 2P)	25 to 95 × 2 (3 to 4/0 × 2P)	35 × 2P (1 × 2P)	25 to 95 × 2P (3 to 4/0 × 2P)	M10	
	⊕	25 (3)	25 to 70 (4 to 2/0)	25 (3)	25 to 70 (3 to 2/0)	M10	17.7 to 22.6 (156 to 200)
	p1, n1	2.5 (14)	2.5 to 4 (14 to 12)	2.5 (14)	2.5 to 4 (14 to 12)	M4	1.2 to 2.0 (10.4 to 17.4)
2□0248	R/L1, S/L2, T/L3	70 × 2 (2/0 × 2P)	35 to 95 × 2 (1 to 4/0 × 2P)	50 × 2P (1/0 × 2P)	35 to 95 × 2P (1 to 4/0 × 2P)	M10	15 to 20 (130 to 173)
	U/T1, V/T2, W/T3	70 × 2 (2/0 × 2P)	35 to 95 × 2 (1 to 4/0 × 2P)	50 × 2P (1/0 × 2P)	35 to 95 × 2P (1 to 4/0 × 2P)	M10	
	⊕	25 (3)	25 to 95 (4 to 4/0)	35 (1)	25 to 95 (3 to 4/0)	M12	31.4 to 39.2 (278 to 347)
	p1, n1	2.5 (14)	2.5 to 4 (14 to 12)	2.5 (14)	2.5 to 4 (14 to 12)	M4	1.2 to 2.0 (10.4 to 17.4)

■ Three-Phase 400 V Class Drives

Table D.3 Drive Wire Gauge and Torque Specifications (Three-Phase 400 V Class)

Drive Model	Terminal	For USA and Canada		For South America		Screw Size	Tightening Torque N·m (lb.in.)
		Recomm. Gauge mm ² (AWG, kcmil)	Wire Range mm ² (AWG, kcmil)	Recomm. Gauge mm ² (AWG, kcmil)	Wire Range mm ² (AWG, kcmil)		
4□0011	R/L1, S/L2, T/L3	2.5 (14)	2.5 to 10 (14 to 8)	2.5 (14)	2.5 to 10 (14 to 8)	M5	2.3 to 2.7 (20.4 to 23.9)
	U/T1, V/T2, W/T3	2.5 (14)	2.5 to 10 (14 to 8)	2.5 (14)	2.5 to 10 (14 to 8)	M5	
	⊕	6 (10)	4 to 16 (12 to 6)	2.5 (14)	2.5 to 16 (14 to 5)	M6	3.9 to 4.9 (34.7 to 43.4)
	p1, n1	2.5 (14)	2.5 to 4 (14 to 12)	2.5 (14)	2.5 to 4 (14 to 12)	M4	1 to 1.4 (8.9 to 12.4)
4□0014	R/L1, S/L2, T/L3	4 (12)	2.5 to 10 (14 to 8)	2.5 (14)	2.5 to 10 (14 to 8)	M5	2.3 to 2.7 (20.4 to 23.9)
	U/T1, V/T2, W/T3	4 (12)	2.5 to 10 (14 to 8)	2.5 (14)	2.5 to 10 (14 to 8)	M5	
	⊕	6 (10)	4 to 16 (12 to 6)	2.5 (14)	2.5 to 16 (14 to 5)	M6	3.9 to 4.9 (34.7 to 43.4)
	p1, n1	2.5 (14)	2.5 to 4 (14 to 12)	2.5 (14)	2.5 to 4 (14 to 12)	M4	1 to 1.4 (8.9 to 12.4)

Drive Model	Terminal	For USA and Canada		For South America		Screw Size	Tightening Torque N·m (lb.in.)
		Recomm. Gauge mm ² (AWG, kcmil)	Wire Range mm ² (AWG, kcmil)	Recomm. Gauge mm ² (AWG, kcmil)	Wire Range mm ² (AWG, kcmil)		
4□0021	R/L1, S/L2, T/L3	6 (10)	4 to 10 (12 to 8)	2.5 (14)	2.5 to 10 (14 to 8)	M5	2.3 to 2.7 (20.4 to 23.9)
	U/T1, V/T2, W/T3	6 (10)	4 to 10 (12 to 8)	2.5 (14)	2.5 to 10 (14 to 8)	M5	
	⊕	6 (10)	4 to 16 (12 to 6)	2.5 (14)	2.5 to 16 (14 to 5)	M6	3.9 to 4.9 (34.7 to 43.4)
	p1, n1	2.5 (14)	2.5 to 4 (14 to 12)	2.5 (14)	2.5 to 4 (14 to 12)	M4	1 to 1.4 (8.9 to 12.4)
4□0027	R/L1, S/L2, T/L3	10 (8)	6 to 10 (10 to 8)	4 (12)	2.5 to 10 (14 to 8)	M5	2.3 to 2.7 (20.4 to 23.9)
	U/T1, V/T2, W/T3	10 (8)	6 to 10 (10 to 8)	4 (12)	2.5 to 10 (14 to 8)	M5	
	⊕	10 (8)	4 to 16 (12 to 6)	4 (12)	4 to 16 (12 to 5)	M6	3.9 to 4.9 (34.7 to 43.4)
	p1, n1	2.5 (14)	2.5 to 4 (14 to 12)	2.5 (14)	2.5 to 4 (14 to 12)	M4	1 to 1.4 (8.9 to 12.4)
4□0034	R/L1, S/L2, T/L3	10 (8)	10 (8)	6 (10)	4 to 10 (12 to 8)	M5	2.3 to 2.7 (20.4 to 23.9)
	U/T1, V/T2, W/T3	10 (8)	10 (8)	6 (10)	4 to 10 (12 to 8)	M5	
	⊕	10 (8)	6 to 16 (10 to 6)	6 (10)	6 to 16 (10 to 5)	M6	3.9 to 4.9 (34.7 to 43.4)
	p1, n1	2.5 (14)	2.5 to 4 (14 to 12)	2.5 (14)	2.5 to 4 (14 to 12)	M4	1 to 1.4 (8.9 to 12.4)
4□0040	R/L1, S/L2, T/L3	10 (8)	10 to 25 (8 to 3)	10 (8)	6 to 25 (10 to 3)	M6	4 to 6 (35.4 to 53.1)
	U/T1, V/T2, W/T3	10 (8)	10 to 25 (8 to 3)	10 (8)	6 to 25 (10 to 3)	M6	
	⊕	10 (8)	10 to 25 (10 to 3)	10 (8)	6 to 25 (10 to 3)	M8	8.8 to 10.8 (78.1 to 95.5)
	p1, n1	2.5 (14)	2.5 to 4 (14 to 12)	2.5 (14)	2.5 to 4 (14 to 12)	M4	1 to 1.4 (8.9 to 12.4)
4□0052	R/L1, S/L2, T/L3	16 (6)	10 to 25 (8 to 3)	10 (8)	10 to 25 (8 to 3)	M6	4 to 6 (35.4 to 53.1)
	U/T1, V/T2, W/T3	16 (6)	10 to 25 (8 to 3)	10 (8)	10 to 25 (8 to 3)	M6	
	⊕	16 (6)	10 to 25 (8 to 3)	10 (8)	10 to 25 (8 to 3)	M8	8.8 to 10.8 (78.1 to 95.5)
	p1, n1	2.5 (14)	2.5 to 4 (14 to 12)	2.5 (14)	2.5 to 4 (14 to 12)	M4	1 to 1.4 (8.9 to 12.4)
4□0065	R/L1, S/L2, T/L3	25 (4)	16 to 25 (6 to 3)	16 (5)	10 to 25 (8 to 3)	M6	4 to 6 (35.4 to 53.1)
	U/T1, V/T2, W/T3	25 (4)	16 to 25 (6 to 3)	16 (5)	10 to 25 (8 to 3)	M6	
	⊕	16 (6)	16 to 25 (6 to 3)	16 (5)	16 to 25 (5 to 3)	M8	8.8 to 10.8 (78.1 to 95.5)
	p1, n1	2.5 (14)	2.5 to 4 (14 to 12)	2.5 (14)	2.5 to 4 (14 to 12)	M4	1 to 1.4 (8.9 to 12.4)
4□0077	R/L1, S/L2, T/L3	25 (3)	25 (4 to 3)	25 (3)	16 to 25 (5 to 3)	M6	4 to 6 (35.4 to 53.1)
	U/T1, V/T2, W/T3	25 (3)	25 (4 to 3)	25 (3)	16 to 25 (5 to 3)	M6	
	⊕	16 (6)	16 to 25 (6 to 3)	16 (5)	16 to 25 (5 to 3)	M8	8.8 to 10.8 (78.1 to 95.5)
	p1, n1	2.5 (14)	2.5 to 4 (14 to 12)	2.5 (14)	2.5 to 4 (14 to 12)	M4	1 to 1.4 (8.9 to 12.4)

D.2 UL Standards

Drive Model	Terminal	For USA and Canada		For South America		Screw Size	Tightening Torque N·m (lb.in.)
		Recomm. Gauge mm ² (AWG, kcmil)	Wire Range mm ² (AWG, kcmil)	Recomm. Gauge mm ² (AWG, kcmil)	Wire Range mm ² (AWG, kcmil)		
4□0096	R/L1, S/L2, T/L3	35 (1)	10 to 50 (8 to 1/0 × 2P)	35 (1)	10 to 50 × 2P (8 to 1/0 × 2P)	M8	8 to 10 (70.8 to 88.5)
	U/T1, V/T2, W/T3	35 (1)	10 to 50 (8 to 1/0 × 2P)	35 (1)	10 to 50 × 2P (8 to 1/0 × 2P)	M8	
	⊕	25 (4)	25 to 35 (4 to 1)	25 (3)	10 to 35 (8 to 1)	M8	8.8 to 10.8 (78.1 to 95.5)
	p1, n1	2.5 (14)	2.5 to 4 (14 to 12)	2.5 (14)	2.5 to 4 (14 to 12)	M4	1.2 to 2.0 (10.4 to 17.4)
4□0124	R/L1, S/L2, T/L3	25 × 2 (4 × 2P)	16 to 50 × 2 (6 to 1/0 × 2P)	16 × 2P (5 × 2P)	10 to 50 × 2P (8 to 1/0 × 2P)	M8	8 to 10 (70.8 to 88.5)
	U/T1, V/T2, W/T3	25 × 2 (4 × 2P)	16 to 50 × 2 (6 to 1/0 × 2P)	16 × 2P (5 × 2P)	10 to 50 × 2P (8 to 1/0 × 2P)	M8	
	⊕	25 (4)	25 to 35 (4 to 1)	16 (5)	16 to 35 (5 to 1)	M8	8.8 to 10.8 (78.1 to 95.5)
	p1, n1	2.5 (14)	2.5 to 4 (14 to 12)	2.5 (14)	2.5 to 4 (14 to 12)	M4	1.2 to 2.0 (10.4 to 17.4)
4□0156	R/L1, S/L2, T/L3	25 × 2 (3 × 2P)	25 to 95 × 2 (4 to 4/0 × 2P)	25 × 2P (3 × 2P)	16 to 95 × 2P (5 to 4/0 × 2P)	M10	15 to 20 (130 to 173)
	U/T1, V/T2, W/T3	25 × 2 (3 × 2P)	25 to 95 × 2 (4 to 4/0 × 2P)	25 × 2P (3 × 2P)	16 to 95 × 2P (5 to 4/0 × 2P)	M10	
	⊕	25 (4)	25 to 70 (4 to 2/0)	25 (3)	25 to 70 (3 to 2/0)	M10	17.7 to 22.6 (156 to 200)
	p1, n1	2.5 (14)	2.5 to 4 (14 to 12)	2.5 (14)	2.5 to 4 (14 to 12)	M4	1.2 to 2.0 (10.4 to 17.4)
4□0180	R/L1, S/L2, T/L3	35 × 2 (2 × 2P)	25 to 95 × 2 (3 to 4/0 × 2P)	25 × 2P (3 × 2P)	25 to 95 × 2P (3 to 4/0 × 2P)	M10	15 to 20 (130 to 173)
	U/T1, V/T2, W/T3	35 × 2 (2 × 2P)	25 to 95 × 2 (3 to 4/0 × 2P)	25 × 2P (3 × 2P)	25 to 95 × 2P (3 to 4/0 × 2P)	M10	
	⊕	25 (3)	25 to 70 (4 to 2/0)	25 (3)	25 to 70 (3 to 2/0)	M10	17.7 to 22.6 (156 to 200)
	p1, n1	2.5 (14)	2.5 to 4 (14 to 12)	2.5 (14)	2.5 to 4 (14 to 12)	M4	1.2 to 2.0 (10.4 to 17.4)
4□0216	R/L1, S/L2, T/L3	50 × 2 (1/0 × 2P)	35 to 95 × 2 (2 to 4/0 × 2P)	35 × 2P (1 × 2P)	25 to 95 × 2P (3 to 4/0 × 2P)	M10	15 to 20 (130 to 173)
	U/T1, V/T2, W/T3	50 × 2 (1/0 × 2P)	35 to 95 × 2 (2 to 4/0 × 2P)	35 × 2P (1 × 2P)	25 to 95 × 2P (3 to 4/0 × 2P)	M10	
	⊕	25 (3)	25 to 95 (4 to 4/0)	35 (1)	25 to 95 (3 to 4/0)	M12	31.4 to 39.2 (278 to 347)
	p1, n1	2.5 (14)	2.5 to 4 (14 to 12)	2.5 (14)	2.5 to 4 (14 to 12)	M4	1.2 to 2.0 (10.4 to 17.4)
4□0240	R/L1, S/L2, T/L3	50 × 2 (1/0 × 2P)	50 to 95 × 2 (1/0 to 4/0 × 2P)	50 × 2P (1/0 × 2P)	35 to 95 × 2P (1 to 4/0 × 2P)	M10	15 to 20 (130 to 173)
	U/T1, V/T2, W/T3	50 × 2 (1/0 × 2P)	50 to 95 × 2 (1/0 to 4/0 × 2P)	50 × 2P (1/0 × 2P)	35 to 95 × 2P (1 to 4/0 × 2P)	M10	
	⊕	35 (2)	35 to 95 (2 to 4/0)	50 (1/0)	35 to 95 (1 to 4/0)	M12	31.4 to 39.2 (278 to 347)
	p1, n1	2.5 (14)	2.5 to 4 (14 to 12)	2.5 (14)	2.5 to 4 (14 to 12)	M4	1.2 to 2.0 (10.4 to 17.4)
4□0302	R/L1, S/L2, T/L3	70 × 2 (3/0 × 2P)	50 to 95 × 2 (1/0 to 4/0 × 2P)	70 × 2P (3/0 × 2P)	50 to 95 × 2P (1/0 to 4/0 × 2P)	M10	15 to 20 (130 to 173)
	U/T1, V/T2, W/T3	70 × 2 (3/0 × 2P)	50 to 95 × 2 (1/0 to 4/0 × 2P)	70 × 2P (3/0 × 2P)	50 to 95 × 2P (1/0 to 4/0 × 2P)	M10	
	⊕	35 (1)	35 to 150 (1 to 300)	70 (3/0)	35 to 150 (1 to 300)	M12	31.4 to 39.2 (278 to 347)
	p1, n1	2.5 (14)	2.5 to 4 (14 to 12)	2.5 (14)	2.5 to 4 (14 to 12)	M4	1.2 to 2.0 (10.4 to 17.4)

Drive Model	Terminal	For USA and Canada		For South America		Screw Size	Tightening Torque N·m (lb.in.)
		Recomm. Gauge mm ² (AWG, kcmil)	Wire Range mm ² (AWG, kcmil)	Recomm. Gauge mm ² (AWG, kcmil)	Wire Range mm ² (AWG, kcmil)		
4□0361	R/L1, S/L2, T/L3	95 × 2 (4/0 × 2P)	70 to 95 × 2 (3/0 to 4/0 × 2P)	95 × 2P (4/0 × 2P)	70 to 95 × 2P (3/0 to 4/0 × 2P)	M10	15 to 20 (130 to 173)
	U/T1, V/T2, W/T3	95 × 2 (4/0 × 2P)	70 to 95 × 2 (3/0 to 4/0 × 2P)	95 × 2P (4/0 × 2P)	70 to 95 × 2P (3/0 to 4/0 × 2P)	M10	
	⊕	50 (1/0)	50 to 150 (1/0 to 300)	95 (4/0)	70 to 150 (3/0 to 300)	M12	31.4 to 39.2 (278 to 347)
	p1, n1	2.5 (14)	2.5 to 4 (14 to 12)	2.5 (14)	2.5 to 4 (14 to 12)	M4	1.2 to 2.0 (10.4 to 17.4)
4□0414	R/L1, S/L2, T/L3	150 × 2 (300 × 2P)	95 to 150 × 2 (4/0 to 300 × 2P)	95 × 2P (4/0 × 2P)	95 to 150 × 2P (4/0 to 300 × 2P)	M12	25 to 35 (217 to 304)
	U/T1, V/T2, W/T3	150 × 2 (300 × 2P)	95 to 150 × 2 (4/0 to 300 × 2P)	95 × 2P (4/0 × 2P)	95 to 150 × 2P (4/0 to 300 × 2P)	M12	
	⊕	50 (1/0)	50 to 240 (1/0 to 400)	95 (4/0)	70 to 240 (3/0 to 400)	M12	31.4 to 39.2 (278 to 347)
	p1, n1	2.5 (14)	2.5 to 4 (14 to 12)	2.5 (14)	2.5 to 4 (14 to 12)	M4	1.2 to 2.0 (10.4 to 17.4)
4□0477	R/L1, S/L2, T/L3	95 × 4P (3/0 × 4P)	150 × 2P 70 to 150 × 4P (300 × 2P 2/0 to 300 × 4P)	120 × 2P (250 × 2P)	95 to 150 × 2P (4/0 to 300 × 2P)	M12	31.4 to 39.2 (278 to 347)
	U/T1, V/T2, W/T3	95 × 4P (3/0 × 4P)	150 × 2P 70 to 150 × 4P (300 × 2P 2/0 to 300 × 4P)	120 × 2P (250 × 2P)	95 to 150 × 2P (4/0 to 300 × 2P)	M12	31.4 to 39.2 (278 to 347)
	⊕	50 (1/0)	50 to 150 (1/0 to 300)	120 (250)	95 to 150 (4/0 to 300)	M12	31.4 to 39.2 (278 to 347)
	p1, n1	2.5 (14)	2.5 to 4 (14 to 12)	2.5 (14)	2.5 to 4 (14 to 12)	M4	1.2 to 2.0 (10.4 to 17.4)
4□0590	R/L1, S/L2, T/L3	120 × 4P (250 × 4P)	95 to 150 × 4P (3/0 to 300 × 4P)	95 × 4P (4/0 × 4P)	120 to 150 × 2P 70 to 150 × 4P (250 to 300 × 2P 2/0 to 300 × 4P)	M12	31.4 to 39.2 (278 to 347)
	U/T1, V/T2, W/T3	120 × 4P (250 × 4P)	95 to 150 × 4P (3/0 to 300 × 4P)	95 × 4P (4/0 × 4P)	120 to 150 × 2P 70 to 150 × 4P (250 to 300 × 2P 2/0 to 300 × 4P)	M12	31.4 to 39.2 (278 to 347)
	⊕	70 (2/0)	70 to 150 (2/0 to 300)	95 × 2P (4/0 × 2P)	120 to 150 95 to 150 × 2P (250 to 300 4/0 to 300 × 2P)	M12	31.4 to 39.2 (278 to 347)
	p1, n1	2.5 (14)	2.5 to 4 (14 to 12)	2.5 (14)	2.5 to 4 (14 to 12)	M4	1.2 to 2.0 (10.4 to 17.4)
4□0720	X, Y, Z	150 × 4P (300 × 4P)	120 to 150 × 4P (250 to 300 × 4P)	120 × 4P (250 × 4P)	95 to 150 × 4P (4/0 to 300 × 4P)	M12	31.4 to 39.2 (278 to 347)
	X1, Y1, Z1	50 (1/0)	50 to 70 (1/0 to 2/0)	35 (1)	35 to 50 (1 to 1/0)	M8	5.4 to 6.0 (47.8 to 53.0)
	U/T1, V/T2, W/T3	150 × 4P (300 × 4P)	120 to 150 × 4P (250 to 300 × 4P)	120 × 4P (250 × 4P)	95 to 150 × 4P (4/0 to 300 × 4P)	M12	31.4 to 39.2 (278 to 347)
	⊕	95 (3/0)	95 to 150 (3/0 to 300)	120 × 2P (250 × 2P)	95 to 150 × 2P (4/0 to 300 × 2P)	M12	31.4 to 39.2 (278 to 347)
	r1, s1, t1	2.5 (14)	2.5 to 4 (14 to 12)	2.5 (14)	2.5 to 4 (14 to 12)	M4	1.2 to 2.0 (10.4 to 17.4)
	p1, n1	2.5 (14)	2.5 to 16 (14 to 6)	2.5 (14)	2.5 to 16 (14 to 6)	M5	2.0 to 2.5 (17.4 to 21.7)
	p2, n2	2.5 (14)	2.5 to 4 (14 to 12)	2.5 (14)	2.5 to 4 (14 to 12)	M4	1.2 to 2.0 (10.4 to 17.4)

D.2 UL Standards

Drive Model	Terminal	For USA and Canada		For South America		Screw Size	Tightening Torque N-m (lb.in.)
		Recomm. Gauge mm ² (AWG, kcmil)	Wire Range mm ² (AWG, kcmil)	Recomm. Gauge mm ² (AWG, kcmil)	Wire Range mm ² (AWG, kcmil)		
4□0930	X, Y, Z	95 × 8P (4/0 × 8P)	95 to 150 × 8P (4/0 to 300 × 8P)	150 × 4P (300 × 4P)	150 × 4P (300 × 4P)	M12	31.4 to 39.2 (278 to 347)
	X1, Y1, Z1	50 (1/0)	50 to 70 (1/0 to 2/0)	35 (1)	35 to 50 (1 to 1/0)	M8	5.4 to 6.0 (47.8 to 53.0)
	U/T1, V/T2, W/T3	95 × 8P (4/0 × 8P)	95 to 150 × 8P (4/0 to 300 × 8P)	150 × 4P (300 × 4P)	150 × 4P (300 × 4P)	M12	31.4 to 39.2 (278 to 347)
	⊕	95 (4/0)	95 to 150 (4/0 to 300)	150 × 2P (300 × 2P)	150 × 2P (300 × 2P)	M12	31.4 to 39.2 (278 to 347)
	r1, s1, t1	2.5 (14)	2.5 to 4 (14 to 12)	2.5 (14)	2.5 to 4 (14 to 12)	M4	1.2 to 2.0 (10.4 to 17.4)
	p1, n1	2.5 (14)	2.5 to 16 (14 to 6)	2.5 (14)	2.5 to 16 (14 to 6)	M5	2.0 to 2.5 (17.4 to 21.7)
	p2, n2	2.5 (14)	2.5 to 4 (14 to 12)	2.5 (14)	2.5 to 4 (14 to 12)	M4	1.2 to 2.0 (10.4 to 17.4)

■ Harmonic Filter Modules

Table D.4 Harmonic Filter Module Wire Gauge and Torque Specifications for Models 4□0720 to 4□0930

Model	Terminal	For USA and Canada		For South America		Screw Size	Tightening Torque N-m (lb.in.)
		Recomm. Gauge mm ² (AWG, kcmil)	Wire Range mm ² (AWG, kcmil)	Recomm. Gauge mm ² (AWG, kcmil)	Wire Range mm ² (AWG, kcmil)		
EUJ71180□.□	R/L1, S/L2, T/L3	150 × 4P (300 × 4P)	120 to 150 × 4P (250 to 300 × 4P)	120 × 4P (250 × 4P)	95 to 150 × 4P (4/0 to 300 × 2P)	M12	31.4 to 39.2 (278 to 347)
	X, Y, Z	150 × 4P (300 × 4P)	120 to 150 × 4P (250 to 300 × 4P)	120 × 4P (250 × 4P)	95 to 150 × 4P (4/0 to 300 × 2P)	M12	31.4 to 39.2 (278 to 347)
	X1, Y1, Z1	50 (1/0)	50 to 70 (1/0 to 2/0)	35 (1)	35 to 50 (1 to 1/0)	M8	5.4 to 6.0 (47.8 to 53.0)
	⊕	95 (3/0)	95 to 150 (3/0 to 300)	120 × 2P (250 × 2P)	95 to 150 × 2P (4/0 to 300)	M12	31.4 to 39.2 (278 to 347)
	r1, s1, t1	2.5 (14)	2.5 to 4 (14 to 12)	2.5 (14)	2.5 to 4 (14 to 12)	M4	1.2 to 2.0 (10.4 to 17.4)
	p2, n2	2.5 (14)	2.5 to 4 (14 to 12)	2.5 (14)	2.5 to 4 (14 to 12)	M4	1.2 to 2.0 (10.4 to 17.4)
EUJ71182□.□	R/L1, S/L2, T/L3	95 × 8P (4/0 × 8P)	95 to 150 × 8P (4/0 to 300 × 8P)	150 × 4P (300 × 4P)	150 × 4P (300 × 4P)	M12	31.4 to 39.2 (278 to 347)
	X, Y, Z	95 × 8P (4/0 × 8P)	95 to 150 × 8P (4/0 to 300 × 8P)	150 × 4P (300 × 4P)	150 × 4P (300 × 4P)	M12	31.4 to 39.2 (278 to 347)
	X1, Y1, Z1	50 (1/0)	50 to 70 (1/0 to 2/0)	35 (1)	35 to 50 (1 to 1/0)	M8	5.4 to 6.0 (47.8 to 53.0)
	⊕	95 (4/0)	95 to 150 (4/0 to 300)	150 × 2P (300 × 2P)	150 × 2P (300 × 2P)	M12	31.4 to 39.2 (278 to 347)
	r1, s1, t1	2.5 (14)	2.5 to 4 (14 to 12)	2.5 (14)	2.5 to 4 (14 to 12)	M4	1.2 to 2.0 (10.4 to 17.4)
	p2, n2	2.5 (14)	2.5 to 4 (14 to 12)	2.5 (14)	2.5 to 4 (14 to 12)	M4	1.2 to 2.0 (10.4 to 17.4)

■ Closed-Loop Crimp Terminal Recommendations

To maintain UL/cUL approval, UL Listed closed-loop crimp terminals are specifically required when wiring the drive main circuit terminals on models 2□0068 to 2□0248 and 4□0052 to 4□0930. Use only the tools recommended by the terminal manufacturer for crimping. Yaskawa recommends UL Listed crimp terminals made by JST and Tokyo DIP (or equivalent) for the insulation cap. [Table D.5](#) matches the wire gauges and terminal screw sizes with Yaskawa-recommended crimp terminals, tools, and insulation caps. Refer to the appropriate Wire Gauge and Torque Specifications table for the wire gauge and screw size for your drive model. Place orders with a Yaskawa representative or the Yaskawa sales department.

Drive Models 2□0028 to 2□0248 and 4□0011 to 4□0590

Table D.5 Closed-Loop Crimp Terminal Size

Drive Model	R/L1, S/L2, T/L3 U/T1, V/T2, W/T3	Screw Size	Crimp Terminal Model Number	Tool		Insulation Cap Model No.	Code <?>	
	Wire Gauge (AWG, kcmil)			Machine No.	Die Jaw			
200 V Class								
2□0028	10	M5	R5.5-5	YA-4	AD-900	TP-005	100-054-030	
	8 <?>		R8-5		AD-901	TP-008	100-054-032	
2□0042	8	M6	R8-6	YA-4	AD-901	TP-008	100-065-184	
	6 <?>		R14-6		AD-902	TP-014	100-051-261	
	4		R22-6	YA-5	AD-953	TP-022	100-051-262	
	3		R22-6		AD-952	TP-014	100-051-261	
2□0054	6	M6	R14-6	YA-5	AD-953	TP-022	100-051-262	
	4 <?>		R22-6		AD-952	TP-014	100-051-261	
	3							
2□0068	4 <?>	M6	R22-6	YA-5	AD-953	TP-022	100-051-262	
	3							
2□0081	6 <?>	M6	R14-6	YA-5	AD-952	TP-014	100-051-261	
	4		R22-6		AD-953	TP-022	100-051-262	
	3							
2□0104	6	M8	R14-8	YA-4	AD-902	TP-014	100-054-035	
	4		R22-8		AD-953	TP-022	100-051-263	
	3		YA-5	R38-8	AD-954	TP-038	100-051-264	
	2			R60-8	AD-955	TP-060	100-051-265	
	1 <?>							
2□0130	6	M8	R14-8	YA-5	AD-952	TP-014	100-054-035	
	4 <?>		R22-8		AD-953	TP-022	100-051-263	
	3		R38-8		AD-954	TP-038	100-051-264	
	2		R60-8		AD-955	TP-060	100-051-265	
	1/0							
2□0154	4	M10	R22-10	YA-5	AD-953	TP-022	100-061-113	
	3 <?>		R38-10		AD-954	TP-038	100-061-114	
	2		R60-10		AD-955	TP-060	100-051-266	
	1		YF-1 YET-300-1	70-10	TD-322 TD-311	TP-080	100-064-251	
	1/0			80-10	TD-323 TD-312		100-051-267	
	2/0			R100-10	YF-1	TD-324	TP-100	100-051-269
	3/0							
2□0192	4/0	M10	R100-10	YA-5	AD-953	TP-022	100-061-113	
	3		R22-10		AD-954	TP-038	100-061-114	
	2		R38-10		AD-955	TP-060	100-051-266	
	1 <?>		R60-10	YF-1 YET-300-1	TD-322 TD-311	TP-080	100-064-251	
	1/0		70-10		TD-323 TD-312		100-051-267	
	2/0		80-10		TD-324	TP-100	100-051-269	
	3/0		R100-10					
4/0								

D.2 UL Standards

Drive Model	R/L1, S/L2, T/L3 U/T1, V/T2, W/T3	Screw Size	Crimp Terminal Model Number	Tool		Insulation Cap Model No.	Code <1>	
	Wire Gauge (AWG, kcmil)			Machine No.	Die Jaw			
2□0248	1	M10	R38-10	YA-5	AD-954	TP-038	100-061-114	
	1/0		R60-10	YF-1 YET-300-1	TD-321 TD-311	TP-060	100-051-266	
	2/0 <2>		70-10		TD-322 TD-311	TP-080	100-064-251	
	3/0		80-10		TD-323 TD-312		100-051-267	
	4/0		R100-10		TD-324 TD-312	TP-100	100-051-269	
400 V Class								
4□0011	14 <2>	M5	R2-5	YA-4	AD-900	TP-003	100-123-030	
	12		R5.5-5			TP-005	100-054-030	
	10				R8-5	AD-901	TP-008	100-054-032
	8							
4□0014	14	M5	R2-5	YA-4	AD-900	TP-003	100-123-030	
	12 <2>		R5.5-5			TP-005	100-054-030	
	10				R8-5	AD-901	TP-008	100-054-032
	8							
4□0021	12	M5	R5.5-5	YA-4	AD-900	TP-005	100-054-030	
	10 <2>				AD-901	TP-008	100-054-032	
	8							
4□0027	10	M5	R5.5-5	YA-4	AD-900	TP-005	100-054-030	
	8 <2>		R8-5		AD-901	TP-008	100-054-032	
4□0034	8 <2>	M5	R8-5	YA-4	AD-901	TP-008	100-054-032	
4□0040	8 <2>	M6	R8-6	YA-4	AD-901	TP-008	100-065-184	
	6		R14-6		AD-902	TP-014	100-051-261	
	4		R22-6	YA-5	AD-953	TP-022	100-051-262	
	3							
4□0052	8	M6	R8-6	YA-4	AD-901	TP-008	100-065-184	
	6 <2>		R14-6		AD-902	TP-014	100-051-261	
	4		R22-6	YA-5	AD-953	TP-022	100-051-262	
	3							
4□0065	6	M6	R14-6	YA-5	AD-952	TP-014	100-051-261	
	4 <2>		R22-6		AD-953	TP-022	100-051-262	
	3							
4□0077	4	M6	R22-6	YA-5	AD-953	TP-022	100-051-262	
	3 <2>							
4□0096	8	M8	R8-8	YA-4	AD-901	TP-008	100-601-111	
	6		R14-8		AD-902	TP-014	100-054-035	
	4		R22-8	YA-5	AD-953	TP-022	100-051-263	
	3							
	2		R38-8	YA-5	AD-954	TP-038	100-051-264	
	1 <2>				R60-8	AD-955	TP-060	100-051-265
	1/0							

Drive Model	R/L1, S/L2, T/L3 U/T1, V/T2, W/T3	Screw Size	Crimp Terminal Model Number	Tool		Insulation Cap Model No.	Code <?>
	Wire Gauge (AWG, kcmil)			Machine No.	Die Jaw		
4□0124	6	M8	R14-8	YA-5	AD-952	TP-014	100-054-035
	4 <?>		R22-8		AD-953	TP-022	100-051-263
	3		R38-8		AD-954	TP-038	100-051-264
	2		R60-8		AD-955	TP-060	100-051-265
	1/0						
4□0156	4	M10	R22-10	YA-5	AD-953	TP-022	100-061-113
	3 <?>		R38-10		AD-954	TP-038	100-061-114
	2		R60-10		AD-955	TP-060	100-051-266
	1		70-10	YF-1 YET-300-1	TD-322 TD-311	TP-080	100-064-251
	1/0		80-10		TD-323 TD-312		100-051-267
	2/0		R100-10		TD-324 TD-312	TP-100	100-051-269
	3/0						
4/0							
4□0180	3	M10	R22-10	YA-5	AD-953	TP-022	100-061-113
	2 <?>		R38-10		AD-954	TP-038	100-061-114
	1		R60-10		AD-955	TP-060	100-051-266
	1/0		70-10	YF-1 YET-300-1	TD-322 TD-311	TP-080	100-064-251
	2/0		80-10		TD-323 TD-312		100-051-267
	3/0		R100-10		TD-324 TD-312	TP-100	100-051-269
	4/0						
4□0216	2	M10	R38-10	YA-5	AD-954	TP-038	100-061-114
	1		R60-10	YF-1 YET-300-1	TD-321 TD-311	TP-060	100-051-266
	1/0 <?>		70-10		TD-322 TD-311	TP-080	100-064-251
	2/0		80-10		TD-323 TD-312		100-051-267
	3/0		R100-10		TD-324 TD-312	TP-100	100-051-269
	4/0						
4□0240	1/0 <?>	M10	R60-10	YF-1 YET-300-1	TD-321 TD-311	TP-060	100-051-266
	2/0		70-10		TD-322 TD-311	TP-080	100-064-251
	3/0		80-10		TD-323 TD-312		100-051-267
	4/0		R100-10		TD-324 TD-312	TP-100	100-051-269
4□0302	1/0	M10	R60-10	YF-1 YET-300-1	TD-321 TD-311	TP-060	100-051-266
	2/0		70-10		TD-322 TD-311	TP-080	100-064-251
	3/0 <?>		80-10		TD-323 TD-312		100-051-267
	4/0		R100-10		TD-324 TD-312	TP-100	100-051-269

D.2 UL Standards

Drive Model	R/L1, S/L2, T/L3 U/T1, V/T2, W/T3	Screw Size	Crimp Terminal Model Number	Tool		Insulation Cap Model No.	Code <1>
	Wire Gauge (AWG, kcmil)			Machine No.	Die Jaw		
4□0361	3/0	M10	80-10	YF-1 YET-300-1	TD-323 TD-312	TP-080	100-051-267
	4/0 <2>		R100-10		TD-324 TD-312	TP-100	100-051-269
4□0414	4/0	M12	R100-12	YF-1 YET-300-1	TD-324 TD-312	TP-100	100-051-270
	250		R150-12		TD-325 TD-313	TP-150	100-051-273
4□0477	2/0	M12	70-12	YF-1 YET-300-1	TD-322 TD-311	TP-080	100-054-036
	3/0 <2>		80-12		TD-323 TD-312	TP-080	100-051-268
	4/0		R100-12		TD-324 TD-312	TP-100	100-051-270
	250		R150-12		TD-325	TP-150	100-051-273
	300		R150-12		TD-313	TP-150	100-051-273
4□0590	3/0	M12	80-12	YF-1 YET-300-1	TD-323 TD-312	TP-080	100-051-268
	4/0		R100-12		TD-324 TD-312	TP-100	100-051-270
	250 <2>		R150-12		TD-325	TP-150	100-051-273
	300		R150-12		TD-313	TP-150	100-051-273

<1> Codes refer to a set of three crimp terminals and three insulation caps. Prepare input and output wiring using two sets for each connection.

<2> Recommended wire gauges. Refer to local codes for proper selections.

Note: Use crimp insulated terminals or insulated shrink tubing for wiring connections. Wires should have a continuous maximum allowable temperature of 75 °C (167 °F) 600 Vac UL-approved vinyl-sheathed insulation.

Drive Models 4□0720 to 4□0930

Table D.6 Closed-Loop Crimp Terminal Size

Drive Model	Wire Gauge (AWG, kcmil)	Screw Size	Crimp Terminal Model Number	Tool		Insulation Cap Model No.	Code <1>
	X, Y, Z U/T1, V/T2, W/T3			Machine No.	Die Jaw		
4□0720	1/0	M12	R60-12	YF-1 YET-300-1	TD-321 TD-311	TP-060	100-066-160
	2/0		70-12		TD-322 TD-311	TP-080	100-054-036
	4/0		R100-12		TD-324 TD-312	TP-100	100-051-270
	250		R150-12		TD-325	TP-150	100-051-273
	300 <2>		R150-12		TD-313	TP-150	100-051-273
4□0930	1/0	M12	R60-12	YF-1 YET-300-1	TD-321 TD-311	TP-060	100-066-160
	2/0		70-12		TD-322 TD-311	TP-080	100-054-036
	4/0 <2>		R100-12		TD-324 TD-312	TP-100	100-051-270
	250		R150-12		TD-325	TP-150	100-051-273
	300		R150-12		TD-313	TP-150	100-051-273

<1> Codes refer to a set of three crimp terminals and three insulation caps. Prepare input and output wiring using two sets for each connection.

<2> Recommended wire gauges. Refer to local codes for proper selections.

Note: Use crimp insulated terminals or insulated shrink tubing for wiring connections. Wires should have a continuous maximum allowable temperature of 75 °C (167 °F) 600 Vac UL-approved vinyl-sheathed insulation.

Harmonic Filter Modules

Table D.7 Harmonic Filter Module Closed-Loop Crimp Terminal Size

Drive Model	Wire Gauge (AWG, kcmil)	Screw Size	Crimp Terminal Model Number	Tool		Insulation Cap Model No.	Code <1>
	R/L1, S/L2, T/L3 X, Y, Z			Machine No.	Die Jaw		
EUJ71180□.□	1/0	M12	R60-12	YF-1 YET-300-1	TD-321 TD-311	TP-060	100-066-160
	2/0		70-12		TD-322 TD-311	TP-080	100-054-036
	4/0		R100-12		TD-324 TD-312	TP-100	100-051-270
	250		R150-12		TD-325 TD-313	TP-150	100-051-273
	300 <2>		R150-12			TP-150	100-051-273
EUJ71182□.□	1/0	M12	R60-12	YF-1 YET-300-1	TD-321 TD-311	TP-060	100-066-160
	2/0		70-12		TD-322 TD-311	TP-080	100-054-036
	4/0 <2>		R100-12		TD-324 TD-312	TP-100	100-051-270
	250		R150-12		TD-325 TD-313	TP-150	100-051-273
	30		R150-12			TP-150	100-051-273

<1> Codes refer to a set of three crimp terminals and three insulation caps. Prepare input and output wiring using two sets for each connection.

<2> Recommended wire gauges. Refer to local codes for proper selections.

Note: Use crimp insulated terminals or insulated shrink tubing for wiring connections. Wires should have a continuous maximum allowable temperature of 75 °C (167 °F) 600 Vac UL-approved vinyl-sheathed insulation.

■ Low Voltage Wiring for Control Circuit Terminals

Wire low voltage wires with NEC Class 1 circuit conductors. Refer to national state or local codes for wiring. The external power supply shall be a UL listed Class 2 power supply source or equivalent only.

Table D.8 Control Circuit Terminal Power Supply

Input / Output	Terminal Signal	Power Supply Specifications
Digital inputs	S1 to S8, SC	Use the internal LVLC power supply of the drive. Use class 2 for external power supply.
Analog inputs / outputs	+V, A1, A2, A3, AC, AM, FM	Use the internal LVLC power supply of the drive. Use class 2 for external power supply.

■ Drive Short Circuit Rating

The drive is suitable for use on a circuit capable of delivering not more than 100,000 RMS symmetrical Amperes, 240 Vac maximum (200 V Class) and 500 Vac maximum (400 V class: 4A□□□□) with built-in fuses manufactured by Hinode Electric Co., Ltd. and Mersen (or equivalent).

■ Branch Circuit Protection

For installation in the United States, branch circuit protection must be provided in accordance with the National Electrical Code (NEC) and any applicable local codes. To fulfill this requirement, use the UL classified fuses.

For installation in Canada, branch circuit protection must be provided in accordance with the Canadian Electrical Code and any applicable provincial codes. To fulfill this requirement, use the UL classified fuses.

◆ Drive Motor Overload Protection

Set parameter E2-01 (motor rated current) to the appropriate value to enable motor overload protection. The internal motor overload protection is UL Listed and in accordance with the NEC and CEC.

■ E2-01: Motor Rated Current

Setting Range: 10% to 150% of the drive rated current

Default Setting: Model-dependent

Parameter E2-01 protects the motor when parameter L1-01 is not set to 0. The default for L1-01 is 1, which enables protection for standard induction motors.

D.2 UL Standards

If Auto-Tuning has been performed successfully, the motor data entered to T1-04 and T2-06 are automatically written to parameter E2-01. If Auto-Tuning has not been performed, manually enter the correct motor rated current to parameter E2-01.

■ L1-01: Motor Overload Protection Selection

The drive has an electronic overload protection function (oL1) based on time, output current, and output frequency that protects the motor from overheating. The electronic thermal overload function is UL-recognized, so it does not require an external thermal relay for single motor operation.

This parameter selects the motor overload curve used according to the type of motor applied.

Table D.9 Overload Protection Settings

Setting	Description	
0	Disabled	Disabled the internal motor overload protection of the drive.
1	Standard fan-cooled motor (default)	Selects protection characteristics for a standard self-cooled motor with limited cooling capabilities when running below the rated speed. The motor overload detection level (oL1) is automatically reduced when running below the motor rated speed.
2	Drive duty motor with a speed range of 1:10	Selects protection characteristics for a motor with self-cooling capability within a speed range of 10:1. The motor overload detection level (oL1) is automatically reduced when running below 1/10 of the motor rated speed.
3	Vector motor with a speed range of 1:100	Selects protection characteristics for a motor capable of cooling itself at any speed including zero speed (externally cooled motor). The motor overload detection level (oL1) is constant over the entire speed range.
6	Standard fan-cooled motor (50 Hz)	Selects protection characteristics for a standard self-cooled motor with limited cooling capabilities when running below the rated speed. The motor overload detection level (oL1) is automatically reduced when running below the motor rated speed.

When connecting the drive to more than one motor for simultaneous operation, disable the electronic overload protection (L1-01 = 0) and wire each motor with its own motor thermal overload relay.

Enable motor overload protection (L1-01 = 1 to 3, 6) when connecting the drive to a single motor, unless another motor overload preventing device is installed. The drive electronic thermal overload function causes an oL1 fault, which shuts off the output of the drive and prevents additional overheating of the motor. The motor temperature is continually calculated while the drive is powered up.

■ L1-02: Motor Overload Protection Time

Setting Range: 0.1 to 5.0 min

Factory Default: 1.0 min

Parameter L1-02 determines how long the motor is allowed to operate before the oL1 fault occurs when the drive is running a hot motor at 60 Hz and at 150% of the full load amp rating (E2-01) of the motor. Adjusting the value of L1-02 can shift the set of oL1 curves up the y axis of the diagram below, but will not change the shape of the curves.

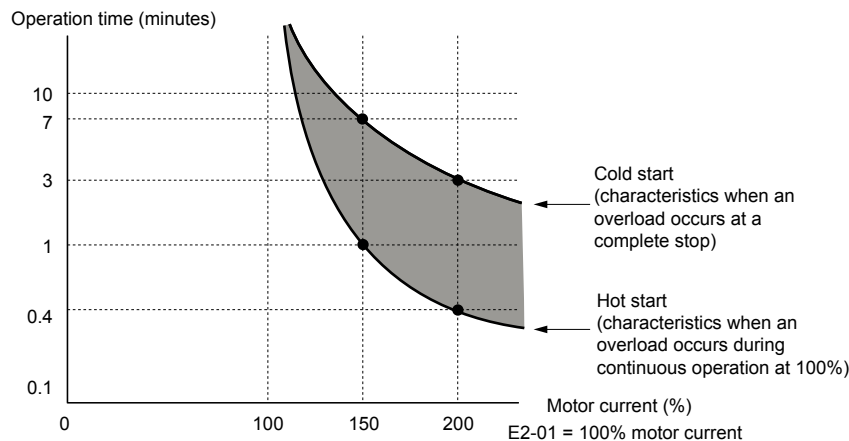

Figure D.2 Motor Overload Protection Time

■ L1-03: Motor Overheat Alarm Operation Selection (PTC input)

Sets the drive operation when the PTC input signal reaches the motor overheat alarm level (oH3).

No.	Name	Setting Range	Default
L1-03	Motor Overheat Alarm Operation Selection (PTC input)	0 to 3	3

Setting 0: Ramp to Stop

The drive stops the motor using the deceleration time 1 set in parameter C1-02.

Setting 1: Coast to Stop

The drive output is switched off and the motor coasts to stop.

Setting 2: Fast Stop

The drive stops the motor using the Fast Stop time set in parameter C1-09.

Setting 3: Alarm Only

The operation is continued and an oH3 alarm is displayed on the digital operator.

■ L1-04: Motor Overheat Fault Operation Selection (PTC input)

Sets the drive operation when the PTC input signal reaches the motor overheat fault level (oH4).

No.	Name	Setting Range	Default
L1-04	Motor Overheat Fault Operation Selection (PTC input)	0 to 2	1

Setting 0: Ramp to Stop

The drive stops the motor using the deceleration time 1 set in parameter C1-02.

Setting 1: Coast to Stop

The drive output is switched off and the motor coasts to stop.

Setting 2: Fast Stop

The drive stops the motor using the Fast Stop time set in parameter C1-09.

Revision History

The revision dates and the numbers of the revised manuals appear on the bottom of the back cover.

MANUAL NO. TOEPYAIUPW01B <1>
 Published in USA February 2017
 Revision number
 Date of publication

Date of Publication	Revision Number	Section	Revised Content
March 2024	<2>	Standards Compliance	Revision: Updated to UL 61800-5-1.
February 2018	<1>	All	Addition: Larger drive capacities and corresponding data Three-phase 400 V: 4□0477 to 4□0930 Harmonic Filter Module: EUJ71180□.□, EUJ71182□.□
February 2017	–	–	First Edition. This manual supports drive software version PRG: 0030

Low Harmonic Regenerative Pump Controller U1000 iQpump MATRIX Drive User Manual

YASKAWA AMERICA, INC.

2121, Norman Drive South, Waukegan, IL 60085, U.S.A.
Phone: 1-800-YASKAWA (927-5292) or 1-847-887-7000 Fax: 1-847-887-7310
<http://www.yaskawa.com>

DRIVE CENTER (INVERTER PLANT)

2-13-1, Nishimiyaichi, Yukuhashi, Fukuoka, 824-8511, Japan
Phone: 81-930-25-3844 Fax: 81-930-25-4369
<http://www.yaskawa.co.jp>

YASKAWA ELECTRIC CORPORATION

New Pier Takeshiba South Tower, 1-16-1, Kaigan, Minatoku, Tokyo, 105-6891, Japan
Phone: 81-3-5402-4502 Fax: 81-3-5402-4580
<http://www.yaskawa.co.jp>

YASKAWA ELÉTRICO DO BRASIL LTDA.

777, Avenida Piraporinha, Diadema, São Paulo, 09950-000, Brasil
Phone: 55-11-3585-1100 Fax: 55-11-3585-1187
<http://www.yaskawa.com.br>

YASKAWA EUROPE GmbH

185, Hauptstraße, Eschborn, 65760, Germany
Phone: 49-6196-569-300 Fax: 49-6196-569-398
<http://www.yaskawa.eu.com>

YASKAWA ELECTRIC KOREA CORPORATION

9F, Kyobo Securities Bldg., 26-4, Yeouido-dong, Yeongdeungpo-gu, Seoul, 150-737, Korea
Phone: 82-2-784-7844 Fax: 82-2-784-8495
<http://www.yaskawa.co.kr>

YASKAWA ELECTRIC (SINGAPORE) PTE. LTD.

151, Lorong Chuan, #04-02A, New Tech Park, 556741, Singapore
Phone: 65-6282-3003 Fax: 65-6289-3003
<http://www.yaskawa.com.sg>

YASKAWA ELECTRIC (THAILAND) CO., LTD.

252/125-126, 27th Floor, Muang Thai-Phatra Tower B, Rachadapisek Road, Huaykwang, Bangkok, 10310, Thailand
Phone: 66-2693-2200 Fax: 66-2693-4200
<http://www.yaskawa.co.th>

YASKAWA ELECTRIC (CHINA) CO., LTD.

22F, One Corporate Avenue, No.222, Hubin Road, Shanghai, 200021, China
Phone: 86-21-5385-2200 Fax: 86-21-5385-3299
<http://www.yaskawa.com.cn>

YASKAWA ELECTRIC (CHINA) CO., LTD. BEIJING OFFICE

Room 1011, Tower W3 Oriental Plaza, No. 1, East Chang An Ave.,
Dong Cheng District, Beijing, 100738, China
Phone: 86-10-8518-4086 Fax: 86-10-8518-4082

YASKAWA ELECTRIC TAIWAN CORPORATION

9F, 16, Nanking E. Rd., Sec. 3, Taipei, 104, Taiwan
Phone: 886-2-2502-5003 Fax: 886-2-2505-1280

YASKAWA INDIA PRIVATE LIMITED

#17/A, Electronics City, Hosur Road, Bangalore, 560 100 (Karnataka), India
Phone: 91-80-4244-1900 Fax: 91-80-4244-1901
<http://www.yaskawaindia.in>

YASKAWA

YASKAWA AMERICA, INC.



In the event that the end user of this product is to be the military and said product is to be employed in any weapons systems or the manufacture thereof, the export will fall under the relevant regulations as stipulated in the Foreign Exchange and Foreign Trade Regulations. Therefore, be sure to follow all procedures and submit all relevant documentation according to any and all rules, regulations and laws that may apply.

Specifications are subject to change without notice for ongoing product modifications and improvements.

© 2017 YASKAWA AMERICA, INC.

MANUAL NO. TOEPYAIUPW01C

Published in USA March 2024 <2>-YAI