

ABB DRIVES FOR HVAC

# ACH580-07

## Hardware manual





# ACH580-07

## Hardware manual

Table of contents



1. Safety instructions



4. Mechanical installation



5. Guidelines for planning the electrical installation



6. Electrical installation



9. Start-up





# Table of contents

---

## 1 Safety instructions

|   |    |
|---|----|
| Contents of this chapter .....                                    | 15 |
| Use of warnings and notes .....                                   | 15 |
| General safety in installation, start-up and maintenance .....    | 16 |
| Electrical safety in installation, start-up and maintenance ..... | 18 |
| Electrical safety precautions .....                               | 18 |
| Additional instructions and notes .....                           | 20 |
| Printed circuit boards .....                                      | 21 |
| Grounding .....   | 21 |
| General safety in operation .....                                 | 22 |
| Additional instructions for permanent magnet motor drives .....   | 23 |
| Safety in installation, start-up, maintenance .....               | 23 |
| Safety in operation .....   | 23 |

## 2 Introduction to the manual

|  |    |
|--|----|
| Contents of this chapter .....                     | 25 |
| Target audience .....                              | 25 |
| Purpose of the manual .....                        | 25 |
| Categorization by frame size and option code ..... | 25 |
| Quick installation flowchart .....                 | 26 |
| Terms and abbreviations .....                      | 26 |
| Related documents .....                            | 27 |

## 3 Operation principle and hardware description

|  |    |
|--|----|
| Contents of this chapter .....   | 29 |
| Product overview .....   | 30 |
| Layout .....   | 31 |
| General information on the cabinet layout .....  | 31 |
| Cabinet layout – R6 and R7 (bottom entry and exit of cables) .....                         | 32 |
| Cabinet layout – R6 and R7 (top entry and exit of cables, options +H351 and +H353) .....   | 33 |
| Cabinet layout – R8 and R9 (bottom entry and exit of cables) .....                         | 34 |
| Cabinet layout – R8 and R9 (top entry and exit of cables, options +H351 and +H353) .....   | 35 |
| Mounting plate – R6 to R9 .....  | 36 |
| Cabinet layout – R10 and R11 (bottom entry and exit of cables) .....                       | 38 |
| Cabinet layout – R10 and R11 (top entry and exit of cables, options +H351 and +H353) ..... | 40 |
| Mounting plate – R10 and R11 .....   | 41 |
| Cooling air flow .....   | 43 |
| Door switches and lights .....   | 44 |
| Main switch-disconnector Q1 .....  | 44 |
| Control panel .....  | 44 |
| Control by PC tools .....  | 45 |
| Common mode filter .....   | 45 |

---

|  |    |
|--|----|
| Overview of power and control connections .....                  | 46 |
| Descriptions of options .....                                    | 46 |
| Degree of protection .....                                       | 47 |
| Definitions .....  | 47 |
| IP21 (UL Type 1) .....   | 47 |
| IP42 (UL Type 1 Filtered) (option +B054) .....                   | 47 |
| IP54 (UL Type 12) (Standard) .....                               | 47 |
| Cooling air inlet through bottom of cabinet (option +C128) ..... | 47 |
| UL Listed (option +C129) .....                                   | 47 |
| Channeled air outlet (option +C130) .....                        | 47 |
| Plinth height (options +C164 and +C179) .....                    | 48 |
| Empty cubicles on right (options +C196...C198) .....             | 48 |
| Empty cubicles on left (options +C199...C201) .....              | 48 |
| EMC filter (option +E202) .....                                  | 48 |
| du/dt filter (option +E205) .....                                | 48 |
| Common mode filter (option +E208) .....                          | 48 |
| Molded case circuit breaker (MCCB, option +F289) .....           | 48 |
| Cabinet heater with external supply (option +G300) .....         | 49 |
| Terminals for external control voltage (option +G307) .....      | 49 |
| Output for motor space heater (option +G313) .....               | 49 |
| Ready/Run/Fault lights (options +G327...G329) .....              | 49 |
| Top cable entry/exit (options +H351 and +H353) .....             | 49 |
| European cable entry (option +H357) .....                        | 50 |
| Cable conduit entry (option +H358) .....                         | 50 |
| Connectivity for wired remote monitoring (option +K496) .....    | 50 |
| Connectivity for wireless remote monitoring (option +K497) ..... | 50 |
| Additional terminal block X504 (option +L504) .....              | 50 |
| Thermal protection with Pt100 relays (option +nL506) .....       | 51 |
| Starter for auxiliary motor fan (options +M600...M605) .....     | 51 |
| What the option contains .....                                   | 51 |
| Description .....  | 51 |
| Type designation label .....                                     | 52 |
| Type designation key .....                                       | 52 |
| Type designation key .....                                       | 52 |
| Basic code .....   | 53 |
| Option codes .....   | 53 |

#### 4 Mechanical installation

|   |    |
|---|----|
| Contents of this chapter .....                            | 57 |
| Examining the installation site .....                     | 57 |
| Necessary tools .....                                     | 58 |
| Moving and unpacking the drive .....                      | 58 |
| Unpacking the transport package .....                     | 60 |
| Examining the delivery .....                              | 61 |
| Lifting the cabinet .....                                 | 61 |
| Lifting lugs .....  | 62 |
| Moving the cabinet after unpacking .....                  | 63 |
| Moving the cabinet on rollers .....                       | 63 |
| Moving the cabinet to its final position .....            | 63 |
| Attaching the cabinet to the floor and wall or roof ..... | 63 |
| General rules .....                                       | 63 |

|  |    |
|--|----|
| Attaching the cabinet (non-marine units) .....   | 65 |
| Alternative 1 – Clamping .....   | 65 |
| Alternative 2 – Using the holes inside the cabinet .....                                       | 66 |
| Alternative 3 – Cabinets with plinth options +C164 and +C179 .....                             | 67 |
| Miscellaneous .....  | 68 |
| Cable duct in the floor below the cabinet .....  | 68 |
| Arc welding .....  | 68 |
| Air inlet through the bottom of the cabinet (option +C128) .....                               | 68 |
| Air outlet duct on the cabinet roof (option +C130) .....                                       | 69 |
| Calculating the required static pressure difference .....                                      | 70 |
| <b>5 Guidelines for planning the electrical installation</b>                                   |    |
| Contents of this chapter .....   | 71 |
| Limitation of liability .....  | 71 |
| North America .....  | 71 |
| Selecting the supply disconnecting device .....  | 71 |
| Selecting the main contactor or breaker .....  | 71 |
| Examining the compatibility of the motor and drive .....                                       | 72 |
| Protecting the motor insulation and bearings .....   | 72 |
| Requirements tables .....  | 72 |
| Requirements for ABB motors, $P_n < 100$ kW (134 hp) .....                                     | 73 |
| Requirements for ABB motors, $P_n \geq 100$ kW (134 hp) .....                                  | 74 |
| Requirements for non-ABB motors, $P_n < 100$ kW (134 hp) .....                                 | 75 |
| Requirements for non-ABB motors, $P_n \geq 100$ kW (134 hp) .....                              | 76 |
| Abbreviations .....  | 76 |
| Availability of $du/dt$ filter and common mode filter by drive type .....                      | 77 |
| Additional requirements for explosion-safe (EX) motors .....                                   | 77 |
| Additional requirements for ABB motors of types other than M2_, M3_, M4_,<br>HX_ and AM_ ..... | 77 |
| Additional requirements for ABB high-output and IP23 motors .....                              | 77 |
| Additional requirements for non-ABB high-output and IP23 motors .....                          | 77 |
| Additional data for calculating the rise time and the peak line-to-line voltage .              | 78 |
| Additional note for sine filters .....   | 79 |
| Selecting the power cables .....   | 80 |
| General guidelines .....   | 80 |
| Typical power cable sizes .....  | 80 |
| Power cable types .....  | 80 |
| Preferred power cable types .....  | 80 |
| Alternate power cable types .....  | 81 |
| Not allowed power cable types .....  | 82 |
| Additional guidelines – North America .....  | 82 |
| Metal conduit .....  | 83 |
| Power cable shield .....   | 83 |
| Grounding requirements .....   | 84 |
| Additional grounding requirements – IEC .....  | 85 |
| Additional grounding requirements – UL (NEC) .....   | 85 |
| Selecting the control cables .....   | 85 |
| Shielding .....  | 85 |
| Signals in separate cables .....   | 86 |
| Signals that can be run in the same cable .....  | 86 |
| Relay cable .....  | 86 |
| Control panel to drive cable .....   | 86 |

|   |    |
|---|----|
| PC tool cable .....   | 86 |
| Routing the cables .....  | 86 |
| General guidelines – IEC .....  | 86 |
| General guidelines – North America .....  | 87 |
| Continuous motor cable shield/conduit and metal enclosure for equipment on the motor cable .....                              | 88 |
| Separate control cable ducts .....  | 88 |
| Protecting the drive, input power cable, motor and motor cable in short circuit situations and against thermal overload ..... | 89 |
| Protecting the drive and input power cable in short-circuit situations .....  | 89 |
| Protecting the motor and motor cable in short-circuits .....  | 89 |
| Protecting the drive and the power cables against thermal overload .....  | 89 |
| Protecting the motor against thermal overload .....   | 90 |
| Protecting the motor against overload without thermal model or temperature sensors .....                                      | 90 |
| Protecting the drive against ground faults .....  | 90 |
| Residual current device compatibility .....   | 90 |
| Implementing the emergency stop function .....  | 91 |
| Implementing the Safe torque off function .....   | 91 |
| Implementing the power loss ride-through function .....   | 91 |
| Using power factor compensation capacitors with the drive .....   | 91 |
| Using a safety switch between the drive and the motor .....   | 92 |
| Implementing an ATEX-certified motor thermal protection .....   | 92 |
| Controlling a contactor between drive and motor .....   | 92 |
| Implementing a bypass connection .....  | 93 |
| Protecting the contacts of relay outputs .....  | 93 |
| Implementing a motor temperature sensor connection .....  | 94 |
| Connecting a motor temperature sensor to the drive through an option module .....   | 95 |
| Supplying power for the auxiliary circuits .....  | 95 |

## 6 Electrical installation

|  |     |
|--|-----|
| Contents of this chapter .....   | 97  |
| Safety .....   | 97  |
| Attaching the device stickers on the cabinet door .....                      | 97  |
| Layout of the cable entries (frames R6...R9) .....                           | 98  |
| Layout of the cable entries (frames R10 and R11) .....                       | 99  |
| Connecting the motor cable at the motor end .....                            | 99  |
| Measuring the insulation .....   | 100 |
| Measuring the insulation resistance of the drive .....                       | 100 |
| Measuring the insulation resistance of the input power cable .....           | 100 |
| Measuring the insulation resistance of the motor and motor cable .....       | 100 |
| Grounding system compatibility check .....                                   | 101 |
| EMC filter option +E202 .....  | 101 |
| Connecting the power cables .....  | 101 |
| Preparing the cable ends and making 360° grounding at the cable entry .....  | 101 |
| Connection diagram .....   | 103 |
| Connection procedure (frames R6...R9) .....                                  | 105 |
| Connection procedure (frames R6 and R7 with options +H351 and +H353) .....   | 107 |
| Connection procedure (frames R8 and R9 with options +H351 and +H353) .....   | 109 |
| Connection procedure (frames R10 and R11) .....                              | 111 |
| Connection procedure (frames R10 and R11 with options +H351 and +H353) ..... | 113 |



|   |     |
|---|-----|
| Connecting the control cables .....   | 115 |
| Overview of control cable connection procedure .....                                      | 116 |
| Grounding the outer shields of the control cables 360° at the cabinet entry ....          | 116 |
| Routing the control cables inside the cabinet .....                                       | 118 |
| Connecting external wiring to the control unit or optional I/O terminal block ...         | 121 |
| Connecting for wired remote monitoring (option +K496) .....                               | 122 |
| Connecting for wireless remote monitoring (option +K497) .....                            | 122 |
| Connecting a 230/115 V AC auxiliary voltage supply (UPS, option +G307) .....              | 123 |
| Connecting the emergency stop push buttons (options +Q951 and +Q963) ....                 | 123 |
| Frames R6...R9 .....  | 123 |
| Frames R10 and R11 .....  | 124 |
| Wiring the starter for auxiliary motor fan (options +M601...M605) .....                   | 124 |
| Connecting the Safe torque off circuit .....  | 124 |
| Connecting external power supply wires for the cabinet heater (option +G300) .            | 124 |
| Connecting external power supply wires for the motor space heater (option<br>+G313) ..... | 125 |
| Wiring the Pt100 relays (option +nL506) .....   | 126 |
| Setting the voltage range of the auxiliary control voltage transformer (T21) .....        | 126 |
| Connecting a PC .....   | 127 |
| Installing option modules .....   | 128 |
| Option slot 1 (fieldbus adapter modules) .....  | 128 |
| Option slot 2 (I/O extension modules) .....   | 129 |
| Wiring the optional modules .....   | 129 |

## 7 Control unit

|   |     |
|---|-----|
| Contents of this chapter .....  | 131 |
| Layout CCU-24 .....   | 132 |
| Default I/O connections for HVAC default .....  | 133 |
| Additional information on the control connections .....                                       | 135 |
| Embedded EIA-485 fieldbus connection .....  | 135 |
| Connecting motor temperature sensors to the drive .....                                       | 136 |
| DI6 for internal overtemperature supervision with option +E205 in frames R10<br>and R11 ..... | 136 |
| PNP configurations for digital inputs .....   | 137 |
| PNP configurations with option +L504 .....  | 137 |
| PNP configurations without option +L504 .....   | 138 |
| NPN configurations for digital inputs .....   | 138 |
| NPN configurations with option +L504 .....  | 138 |
| NPN configurations without option +L504 .....   | 138 |
| Connection for obtaining 0...10 V from analog output 2 (AO2) .....                            | 139 |
| Connection examples of two-wire and three-wire sensors to analog input (AI2) .                | 139 |
| DI5 as frequency input .....  | 140 |
| Safe torque off (X4) .....  | 140 |
| CCU-24 technical data .....   | 140 |

## 8 Installation checklist

|                                |     |
|--------------------------------|-----|
| Contents of this chapter ..... | 145 |
| Checklist .....                | 145 |

## 9 Start-up

|                                |     |
|--------------------------------|-----|
| Contents of this chapter ..... | 147 |
|--------------------------------|-----|



Start-up procedure ..... 147

**10 Fault tracing**

Contents of this chapter ..... 149  
 Warning and fault messages ..... 149

**11 Maintenance**

Contents of this chapter ..... 151  
 Maintenance intervals ..... 151  
     Description of symbols ..... 151  
     Recommended maintenance intervals after start-up ..... 152  
 Cleaning the interior of the cabinet ..... 153  
 Cleaning the exterior of the drive ..... 153  
 Cleaning the air inlet (door) meshes (IP42 / UL Type 1 Filtered) ..... 155  
 Replacing the air filters (IP54 / UL Type 12) ..... 156  
     Inlet (door) filters (IP54 / UL Type 12) ..... 156  
     Outlet (roof) filters (IP54 / UL Type 12) ..... 156  
 Cleaning the interior of the heatsink (frames R10 and R11) ..... 157  
 Fans ..... 157  
     Replacing the door fan (frames R6...R9) ..... 158  
     Replacing the cabinet fan (frames R6...R9) ..... 159  
     Replacing the door fan (frames R10 and R11) ..... 160  
     Replacing the cabinet fan (frames R10 and R11, IP54 / UL Type 12) ..... 162  
     Replacing the drive module main cooling fan (frames R6...R8) ..... 163  
     Replacing the drive module main cooling fans (frame R9) ..... 164  
     Replacing the drive module main cooling fans (frames R10 and R11) ..... 165  
     Replacing the auxiliary cooling fan of the drive module (frames R6...R9) ..... 166  
     Replacing the circuit board compartment cooling fans (frames R10 and R11) ... 167  
 Replacing the drive module (frames R6...R9) ..... 168  
 Replacing the drive module (frames R10 and R11) ..... 174  
 Replacing the drive module (frames R10 and R11, IP54 / UL Type 12) ..... 180  
 Capacitors ..... 186  
     Reforming the capacitors ..... 186  
 Fuses ..... 186  
     Replacing AC fuses (frames R6 and R7) ..... 186  
     Replacing AC fuses (frames R10 and R11) ..... 188  
 Control panel ..... 188  
 Functional safety components ..... 189

**12 Technical data**

Contents of this chapter ..... 191  
 Electrical ratings ..... 191  
     IEC ratings ..... 191  
     UL (NEC) ratings ..... 192  
     Definitions ..... 193  
 Output derating ..... 194  
     Ambient temperature derating ..... 194  
         Drive types other than -0414A-4 and -0430A-4 ..... 194  
         Drive types -0414A-4 and -0430A-4 ..... 194  
     Altitude derating ..... 194  
     Deratings for special settings in the drive control program ..... 196



|  |     |
|--|-----|
| Fuses (IEC) .....  | 197 |
| Fuses (UL) .....   | 198 |
| Fuses for branch circuit protection .....  | 199 |
| Dimensions and weights .....   | 200 |
| Free space requirements .....  | 201 |
| Maximum allowed plinth height for the extraction/installation ramp .....                                 | 201 |
| Typical power cables .....   | 201 |
| Losses, cooling data and noise .....   | 202 |
| Terminal and entry data for the power cables .....   | 204 |
| IEC – Standard configuration .....   | 204 |
| IEC – With option +E205 .....  | 205 |
| US – Standard configuration .....  | 205 |
| US – With option +E205 .....   | 205 |
| Dimension drawings .....   | 206 |
| Terminal and connection data for auxiliary control circuits .....  | 231 |
| Electrical power network specification .....   | 232 |
| Motor connection data .....  | 232 |
| Control unit connection data .....   | 232 |
| Efficiency .....   | 232 |
| Energy efficiency data (ecodesign) .....   | 233 |
| Protection classes .....   | 233 |
| Ambient conditions .....   | 234 |
| Transportation .....   | 235 |
| Storage conditions .....   | 235 |
| Auxiliary circuit power consumption .....  | 236 |
| Color .....  | 236 |
| Materials .....  | 237 |
| Drive .....  | 237 |
| Package materials for cabinet-installed low-power single drives .....                                    | 237 |
| Package materials for options, accessories and spare parts .....   | 237 |
| Materials of manuals .....   | 237 |
| Disposal .....   | 237 |
| Package dimensions and weights for drives without empty cubicles (without options +C196 ... +C201) ..... | 238 |
| Package weights .....  | 238 |
| Applicable standards .....   | 239 |
| Markings .....   | 239 |
| CE marking .....   | 240 |
| Compliance with the European Low Voltage Directive .....   | 241 |
| Compliance with the European EMC Directive .....   | 241 |
| Compliance with the European Machinery Directive .....   | 241 |
| Compliance with the EN 61800-3:2004 .....  | 241 |
| Definitions .....  | 241 |
| Category C2 .....  | 241 |
| Category C3 .....  | 242 |
| Category C4 .....  | 242 |
| UL marking .....   | 243 |
| UL checklist .....   | 243 |
| Design lifetime expectancy .....   | 244 |
| Disclaimers .....  | 245 |
| Generic disclaimer .....   | 245 |
| Cyber security disclaimer .....  | 245 |



|                                  |     |
|----------------------------------|-----|
| Declarations of conformity ..... | 246 |
|----------------------------------|-----|

### 13 Dimension drawings

|  |     |
|--|-----|
| Frames R6 and R7 (+B052: IP21, UL Type 1) .....                          | 248 |
| Frames R6 and R7 (+B054: IP42, UL Type 1 Filtered) .....                 | 249 |
| Frames R6 and R7 (+B055: IP54, UL Type 12) .....                         | 250 |
| Frames R6 and R7 (+H351 and +H353: top entry and exit) .....             | 251 |
| Frames R6 and R7 (+F289) .....   | 252 |
| Frames R6 and R7 (+F289, +H351, +H353) .....                             | 253 |
| Frames R8 and R9 (IP21, UL Type 1) .....                                 | 254 |
| Frames R8 and R9 (+B054: IP42, UL Type 1 Filtered) .....                 | 255 |
| Frames R8 and R9 (+B055: IP54, UL Type 12) .....                         | 256 |
| Frames R8 and R9 (+H351 and +H353: top entry and exit) .....             | 257 |
| Frames R8 and R9 (+F289) .....   | 258 |
| Frames R8 and R9 (+F289, +H351, +H353) .....                             | 259 |
| Frames R10 and R11 (IP21, UL Type 1) .....                               | 260 |
| Frames R10 and R11 (+B054: IP42, UL Type 1 Filtered) .....               | 261 |
| Frames R10 and R11 (+B055: IP54, UL Type 12) .....                       | 262 |
| Frames R10 and R11 (+F289) .....   | 263 |
| Frames R10 and R11 (+H351, +H353) .....                                  | 264 |
| Frames R10 and R11 (+B054: IP42, UL type 1 filtered, +H351, +H353) ..... | 265 |
| Frames R10 and R11 (+B055: IP54, UL type 12, +H351, +H353) .....         | 266 |
| Dimensions of empty cubicles (options +C196...+C201) .....               | 267 |
| IP22/IP42 .....  | 267 |
| IP54 .....   | 268 |

### 14 The Safe torque off function

|  |     |
|--|-----|
| Contents of this chapter .....   | 269 |
| Description .....  | 269 |
| Compliance with the European Machinery Directive and the UK Supply of Machinery (Safety) Regulations ..... | 270 |
| Wiring .....   | 271 |
| Connection principle .....   | 271 |
| Single ACH580-07 drive, internal power supply .....  | 271 |
| Single ACH580-07 drive, external power supply .....  | 271 |
| Wiring examples .....  | 272 |
| Single ACH580-07 drive, internal power supply .....  | 272 |
| Single ACH580-07 drive, external power supply .....  | 272 |
| Multiple ACH580-07 drives, internal power supply .....   | 273 |
| Multiple ACH580-07 drives, external power supply .....   | 274 |
| Activation switch .....  | 274 |
| Cable types and lengths .....  | 275 |
| Grounding of protective shields .....  | 275 |
| Operation principle .....  | 276 |
| Start-up including validation test .....   | 277 |
| Competence .....   | 277 |
| Validation test reports .....  | 277 |
| Validation test procedure .....  | 277 |
| Use .....  | 279 |
| Maintenance .....  | 281 |
| Competence .....   | 281 |

|                               |     |
|-------------------------------|-----|
| Fault tracing .....           | 282 |
| Safety data .....             | 283 |
| Terms and abbreviations ..... | 285 |
| TÜV certificate .....         | 286 |

## 15 Disconnecting EMC filter and ground-to-phase varistor

|  |     |
|--|-----|
| When to disconnect the ground-to-phase varistor: TN-S, IT, corner-grounded delta, midpoint-grounded delta and TT systems ..... | 287 |
| Identifying the grounding system of the electrical power network .....   | 289 |
| Disconnecting the EMC filter and ground-to-phase varistor (IEC frames R6...R9) ..  | 290 |
| Disconnecting internal EMC filter or ground-to-phase varistor (UL/NEC frames R6...R9) .....                                    | 290 |
| Disconnecting the ground-to-phase varistor (frames R10 and R11) .....  | 291 |

## 16 CAIO-01 bipolar analog I/O adapter module

|  |     |
|--|-----|
| Contents of this chapter .....             | 293 |
| Product overview .....                     | 293 |
| Layout .....                               | 294 |
| Mechanical installation .....              | 295 |
| Necessary tools .....                      | 295 |
| Unpacking and examining the delivery ..... | 295 |
| Installing the module .....                | 295 |
| Electrical installation .....              | 295 |
| Necessary tools .....                      | 295 |
| Wiring .....                               | 295 |
| Start-up .....                             | 296 |
| Setting the parameters .....               | 296 |
| Diagnostics .....                          | 296 |
| LEDs .....                                 | 296 |
| Technical data .....                       | 296 |
| Isolation areas .....                      | 297 |
| Dimension drawings .....                   | 298 |

## 17 CHDI-01 115/230 V digital input extension module

|  |     |
|--|-----|
| Contents of this chapter .....                   | 299 |
| Product overview .....                           | 299 |
| Layout and connection examples .....             | 300 |
| Mechanical installation .....                    | 301 |
| Necessary tools .....                            | 301 |
| Unpacking and examining the delivery .....       | 301 |
| Installing the module .....                      | 301 |
| Electrical installation .....                    | 301 |
| Necessary tools .....                            | 301 |
| Wiring .....                                     | 301 |
| Start-up .....                                   | 301 |
| Setting the parameters .....                     | 301 |
| Parameter setting example for relay output ..... | 301 |
| Fault and warning messages .....                 | 302 |
| Technical data .....                             | 302 |
| Dimension drawing .....                          | 302 |



**18 CMOD-01 multifunction extension module (external 24 V AC/DC and digital I/O)**

Contents of this chapter ..... 305

Product overview ..... 305

Layout and example connections ..... 306

Mechanical installation ..... 307

    Necessary tools ..... 307

    Unpacking and examining the delivery ..... 307

    Installing the module ..... 307

Electrical installation ..... 307

    Necessary tools ..... 307

    Wiring ..... 307

Start-up ..... 307

    Setting the parameters ..... 307

    Diagnostics ..... 308

        Faults and warning messages ..... 308

        LEDs ..... 308

Technical data ..... 308

Dimension drawing ..... 309

**19 CMOD-02 multifunction extension module (external 24 V AC/DC and isolated PTC interface)**

Contents of this chapter ..... 311

Product overview ..... 311

Layout and example connections ..... 312

Mechanical installation ..... 312

    Necessary tools ..... 312

    Unpacking and examining the delivery ..... 313

    Installing the module ..... 313

Electrical installation ..... 313

    Necessary tools ..... 313

    Wiring ..... 313

Start-up ..... 313

    Setting the parameters ..... 313

Diagnostics ..... 313

    Faults and warning messages ..... 313

    LEDs ..... 314

Technical data ..... 314

Dimension drawing ..... 315

**Further information**



# 1

## Safety instructions

---



### Contents of this chapter

This chapter contains the safety instructions which you must obey when you install, start-up, operate and do maintenance work on the drive. If you ignore the safety instructions, injury, death or damage can occur.

### Use of warnings and notes

Warnings tell you about conditions which can cause injury or death, or damage to the equipment. They also tell you how to prevent the danger. Notes show a particular condition or fact, or give information.

The manual uses these warning symbols:

**WARNING!**

Electricity warning tells about hazards from electricity which can cause injury or death, or damage to the equipment.

---

**WARNING!**

General warning tells about conditions other than those caused by electricity, which can cause injury or death, or damage to the equipment.

---

**WARNING!**

Electrostatic sensitive devices warning tells you about the risk of electrostatic discharge which can cause damage to the equipment.

---

## General safety in installation, start-up and maintenance

These instructions are for all persons who do work on the drive.



### WARNING!

Obey these instructions. If you ignore them, injury or death, or damage to the equipment can occur.

- Keep the drive in its package until you install it. After unpacking, protect the drive from dust, debris and moisture.
- Use the required personal protective equipment: safety shoes with metal toe cap, safety glasses, protective gloves and long sleeves, etc. Some parts have sharp edges.
- Use a lifting device to lift a heavy drive. Use the designated lifting points. Refer to the dimension drawings.
- Obey the local laws and regulations that apply to lifting, such as the requirements for planning the lift, the capacity and condition of the lifting equipment, and personnel training.
- Attach the drive cabinet to the floor to prevent it from falling over. The cabinet has a high center of gravity. When you pull out heavy components or power modules, there is a risk of overturning. Attach the cabinet also to the wall when necessary.

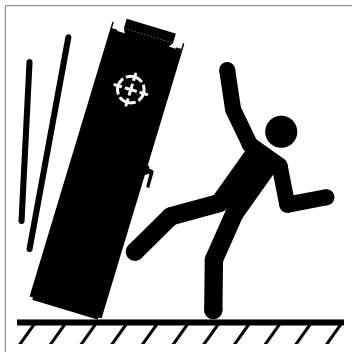

- Do not stand or walk on the cabinet roof. Make sure that nothing presses against the roof, side or back plates or door. Do not store anything on the roof while the drive is in operation.
- Beware of hot surfaces. Some parts, such as heatsinks of power semiconductors, and brake resistors, can be hot for a period after operation.
- Before the start-up, vacuum clean the area around the drive to prevent the drive cooling fan from drawing dust inside the drive.
- Make sure that debris from drilling, cutting and grinding does not go into the drive during installation. Electrically conductive debris inside the drive can cause damage or malfunction.
- Make sure that there is sufficient cooling. Refer to the technical data.
- Keep the drive cabinet doors closed when the drive has electrical power. If the doors of the drive cabinet are open, there is a risk of a potentially fatal electric shock, arc flash or high-energy arc blast exists.



- If you must do work on a drive that is connected to the power supply, obey the local laws and regulations on live electrical work. This includes, but is not limited to, electric shock and arc protection.
- Before you adjust the drive operation limits, make sure that the motor and all driven equipment can operate throughout the set operation limits.
- Before you activate the automatic fault reset or automatic restart functions of the drive control program, make sure that no dangerous situations can occur. These functions reset the drive automatically and continue operation after a fault or break in the power supply. If these functions are activated, the installation must be clearly marked as defined in IEC/EN/UL 61800-5-1, subclause 6.5.3, for example, "THIS MACHINE STARTS AUTOMATICALLY".
- The maximum number of drive power-ups is five in ten minutes. Too frequent power-ups can damage the charging circuit of the DC capacitors.
- If the drive has connected safety circuits (for example, Safe torque off or emergency stop), validate them at start-up. Refer to separate instructions for the safety circuits.
- Beware of hot air flow from the cooling outlets.
- Do not cover the air inlet or air outlet when the drive operates.

**Note:**

- If you select an external source for the start command and it is on, the drive starts immediately after a fault reset unless you configure the drive for pulse start. Refer to the firmware manual.
- If the drive is in remote control mode, you cannot stop or start the drive with the control panel.
- Only authorized persons are permitted to repair a faulty drive.



## Electrical safety in installation, start-up and maintenance

### ■ Electrical safety precautions

These electrical safety precautions are for all persons who do work on the drive, motor cable or motor.



#### **WARNING!**

Obey these instructions. If you ignore them, injury or death, or damage to the equipment can occur. If you are not a qualified electrical professional, do not do electrical installation or maintenance work. Do these steps before you do installation or maintenance work.

1. Prepare for the work.
  - Make sure that you have a work order.
  - Do an on-site risk assessment or job hazard analysis.
  - Make sure that you have the correct tools available.
  - Make sure that the workers are qualified.
  - Select the correct personal protective equipment (PPE).
  - Stop the drive and motor(s).
2. Clearly identify the work location and equipment.
3. Disconnect all possible voltage sources. Make sure that connection is not possible. Lock out and tag out.
  - Open the main disconnecting device of the drive.
  - Open the charging switch if it is present.
  - Open the disconnecter of the supply transformer. (The main disconnecting device in the drive cabinet does not disconnect the voltage from the AC input power busbars of the drive cabinet.)
  - Open the auxiliary voltage switch-disconnector (if it is present), and all other possible disconnecting devices that isolate the drive from dangerous voltage sources.
  - If a permanent magnet motor connects to the drive, disconnect the motor from the drive with a safety switch or by other means.
  - Open the main isolating device of the drive.
  - Disconnect all dangerous external voltages from the control circuits.
  - After you disconnect power from the drive, wait 5 minutes to let the intermediate circuit capacitors discharge before you continue.
4. Protect other energized parts in the work location against contact and take special precautions when close to bare conductors.
5. Measure that the installation is de-energized. Use a high-quality voltage tester. If the measurement requires that you remove shrouding or other cabinet structures, obey the local laws and regulations applicable to live electrical work. This includes, but is not limited to, electric shock and arc protection.
  - Before and after you measure the installation, verify the operation of the voltage tester on a known voltage source.
  - Make sure that the voltage between the input power terminals of the drive (L1, L2, L3) and the grounding (PE) busbar is zero.



Measuring points of frames R6...R9 are shown below.

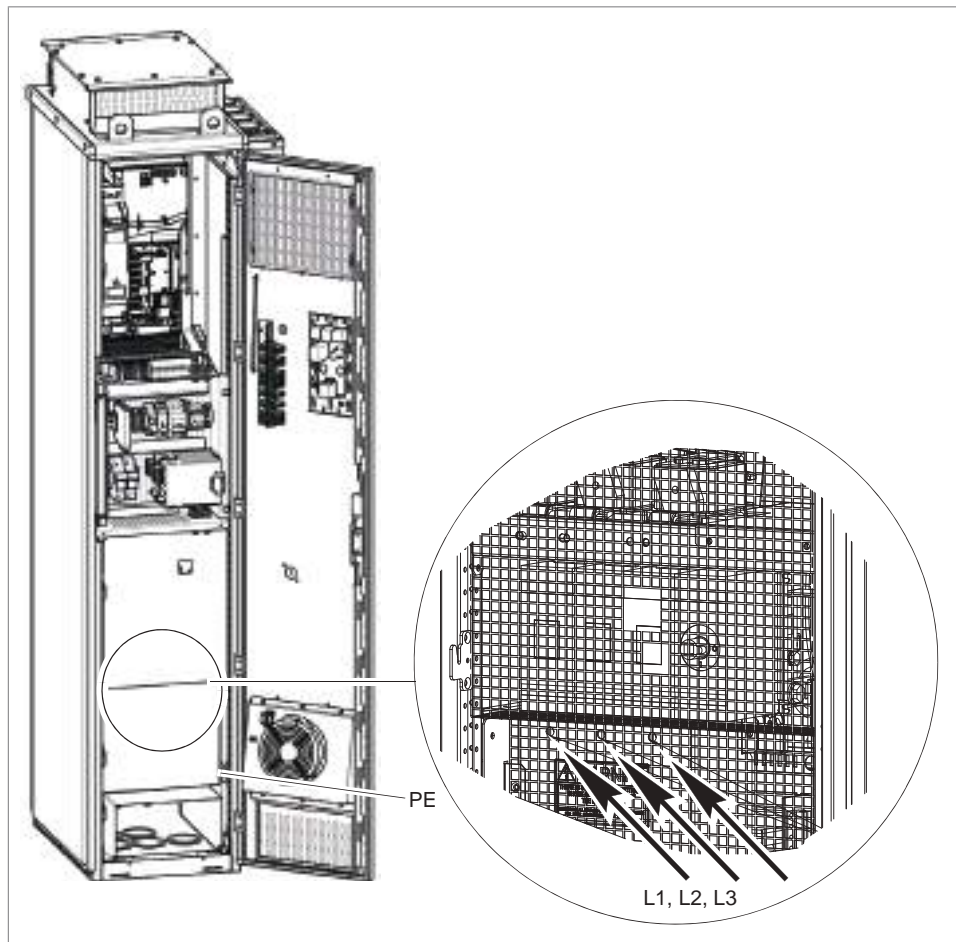

Measuring points of frames R10 and R11 are shown below. You can also remove the metallic shield and measure through the holes in the clear plastic shroud behind it.

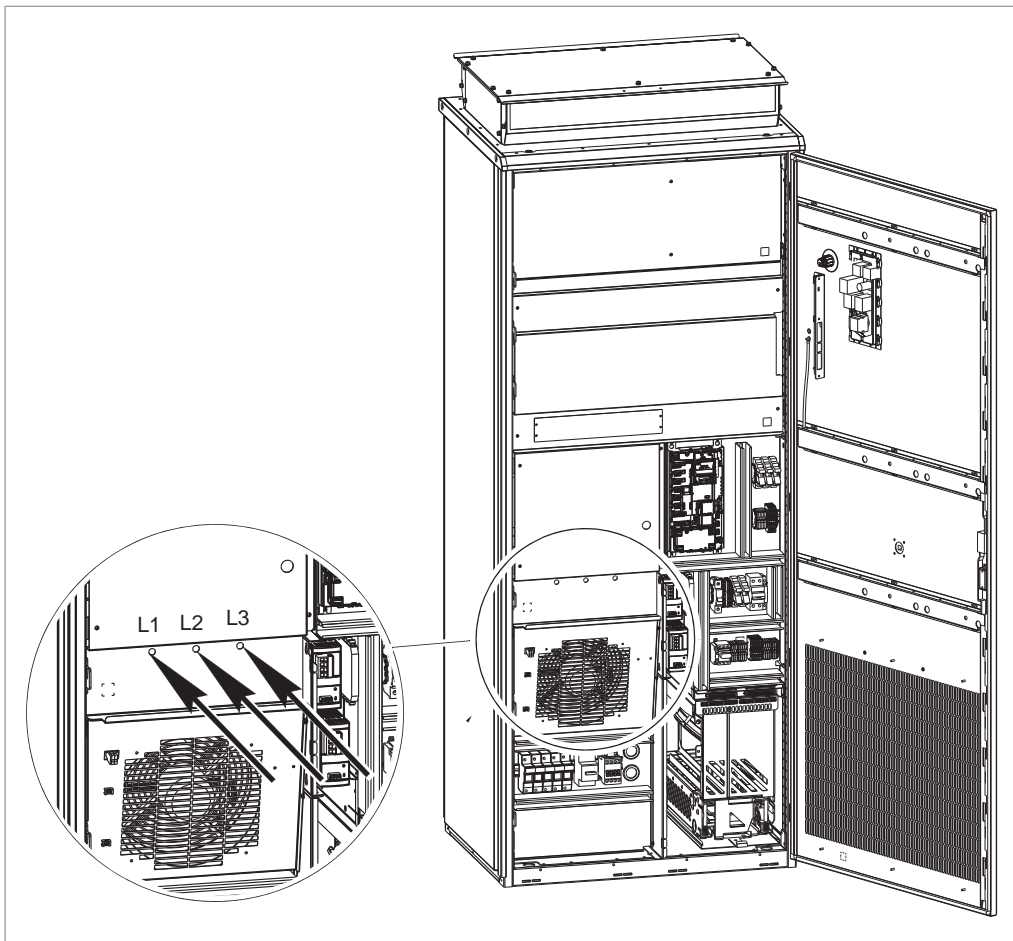

- Make sure that the voltage between the output power terminals of the drive (U, V, W) and the grounding (PE) busbar is zero. Important! Repeat the measurement with the DC voltage setting of the voltage tester. Measure between each phase and ground. There is a risk of dangerous DC voltage charging due to leakage capacitances of the motor circuit. This voltage can remain charged for a long time after the drive power-off. The measurement discharges the voltage.
6. Install temporary grounding as required by the local regulations.
  7. Ask for a permit to work from the person that is responsible for the electrical installation work.

#### ■ Additional instructions and notes



#### **WARNING!**

Obey these instructions. If you ignore them, injury or death, or damage to the equipment can occur.

If you are not a qualified electrical professional, do not do installation or maintenance work.

- Keep the cabinet doors closed when the drive has electrical power. If the doors the drive cabinet are open, there is a risk of a potentially fatal electric shock, arc flash or high-energy arc blast exists.
- Make sure that the electrical power network, motor/generator, and environmental conditions agree with the drive data.
- Do not do insulation or voltage withstand tests on the drive.
- If you have a cardiac pacemaker or other electronic medical device, do not go near the motor, drive, and the drive power cabling when the drive is in operation. The equipment produces electromagnetic fields that can cause interference in electronic medical devices. This can cause a health hazard.
- ABB does not recommend attaching the cabinet by arc welding. If you have to, obey the welding instructions in the drive manuals.

**Note:**

- When the drive is connected to the input power, the motor cable terminals and the DC bus are at a dangerous voltage.  
After you disconnect the drive from the input power, these remain at a dangerous voltage until the intermediate circuit capacitors discharge.
- External wiring can supply dangerous voltages to the relay outputs of the control units of the drive.
- The Safe torque off function does not remove the voltage from the main and auxiliary circuits. The function is not effective against deliberate sabotage or misuse.

**Printed circuit boards****WARNING!**

Use ESD wristband when you handle printed circuit boards. Do not touch the boards unnecessarily. The boards are sensitive to electrostatic discharge.

### ■ Grounding

These instructions are for all persons who are responsible for the grounding of the drive.

**WARNING!**

Obey these instructions. If you ignore them, injury or death, or equipment malfunction can occur, and electromagnetic interference can increase.

If you are not a qualified electrical professional, do not do grounding work.

- Always ground the drive, the motor and adjoining equipment. This is necessary for personnel safety.
- Make sure that the conductivity of the protective earth (PE) conductors is sufficient and that other requirements are met. Refer to the electrical planning instructions of the drive. Obey the applicable national and local regulations.
- When you use shielded cables, make a 360° grounding of the cable shields at the cable entries to reduce electromagnetic emission and interference.
- In a multiple-drive installation, connect each drive separately to the protective earth (PE) busbar of the power supply.



## General safety in operation

These instructions are for all persons that operate the drive.

---



### **WARNING!**

Obey these instructions. If you ignore them, injury or death, or damage to the equipment can occur.

---

- Keep the cabinet doors closed when the drive has electrical power. If the doors the drive cabinet are open, there is a risk of a potentially fatal electric shock, arc flash or high-energy arc blast exists.
- If you have a cardiac pacemaker or other electronic medical device, do not go near the motor, drive, and the drive power cabling when the drive is in operation. The equipment produces electromagnetic fields that can cause interference in electronic medical devices. This can cause a health hazard.
- Give a stop command to the drive before you reset a fault. If you have an external source for the start command and the start is on, the drive starts immediately after the fault reset, unless you configure the drive for pulse start. Refer to the firmware manual.
- Before you activate the automatic fault reset or automatic restart functions of the drive control program, make sure that no dangerous situations can occur. These functions reset the drive automatically and continue operation after a fault or break in the power supply. If these functions are activated, the installation must be clearly marked as defined in IEC/EN/UL 61800-5-1, subclause 6.5.3, for example, "THIS MACHINE STARTS AUTOMATICALLY".



### **Note:**

- The maximum number of drive power-ups is five in ten minutes. Too frequent power-ups can damage the charging circuit of the DC capacitors. If you need to start or stop the drive, use the control panel keys or commands through the I/O terminals of the drive or the fieldbus interface.
  - If the drive is in remote control mode, you cannot stop or start the drive with the control panel.
-

## Additional instructions for permanent magnet motor drives

### ■ Safety in installation, start-up, maintenance

These are additional warnings for permanent magnet motor drives. The other safety instructions in this chapter are also valid.

**WARNING!**

Obey these instructions. If you ignore them, injury or death, or damage to the equipment can occur.

If you are not a qualified electrical professional, do not do installation or maintenance work.

---

- Do not do work on the drive when a rotating permanent magnet motor is connected to it. A rotating permanent magnet motor energizes the drive including its input and output power terminals.

Before installation, start-up and maintenance work on the drive:

- Stop the drive.
- Disconnect the motor from the drive with a safety switch or by other means.
- If you cannot disconnect the motor, make sure that the motor cannot rotate during work. Make sure that no other system, like hydraulic crawling drives, can rotate the motor directly or through any mechanical connection such as belt, nip, rope, etc.
- Do the steps in section [Electrical safety precautions \(page 18\)](#).
- Install temporary grounding to the drive output terminals (T1/U, T2/V, T3/W). Connect the output terminals together as well as to the PE.

During the start-up:

- Make sure that the motor cannot run at overspeed, for example, when it is driven by the load. Motor overspeed causes an overvoltage that can cause damage to the capacitors in the intermediate circuit of the drive.

### ■ Safety in operation

**WARNING!**

Make sure that the motor cannot run at overspeed, for example, when it is driven by the load. Motor overspeed causes an overvoltage that can cause damage to the capacitors in the intermediate circuit of the drive.

---







# Introduction to the manual

---

## Contents of this chapter

This chapter describes the intended audience and contents of the manual. It contains a flowchart of steps in examining the delivery, installing and commissioning the drive. The flowchart refers to chapters/sections in this manual and other manuals.

## Target audience

This manual is intended for people who plan the installation, install, commission, and do maintenance work on the drive, or create instructions for the end user of the drive concerning the installation and maintenance of the drive.

Read the manual before you do work on the drive. You are expected to know the fundamentals of electricity, wiring, electrical components, and electrical schematic symbols.

## Purpose of the manual

This manual provides information needed for planning the installation, installing, and servicing the drive.

## Categorization by frame size and option code

The frame size identifies information which concerns only a certain frame size of the drive. The frame size is shown on the type designation label. All frame sizes are listed in the technical data.

The option code (A123) identifies information which concerns only a certain optional selection. The options included in the drive are listed on the type designation label.

---

## Quick installation flowchart

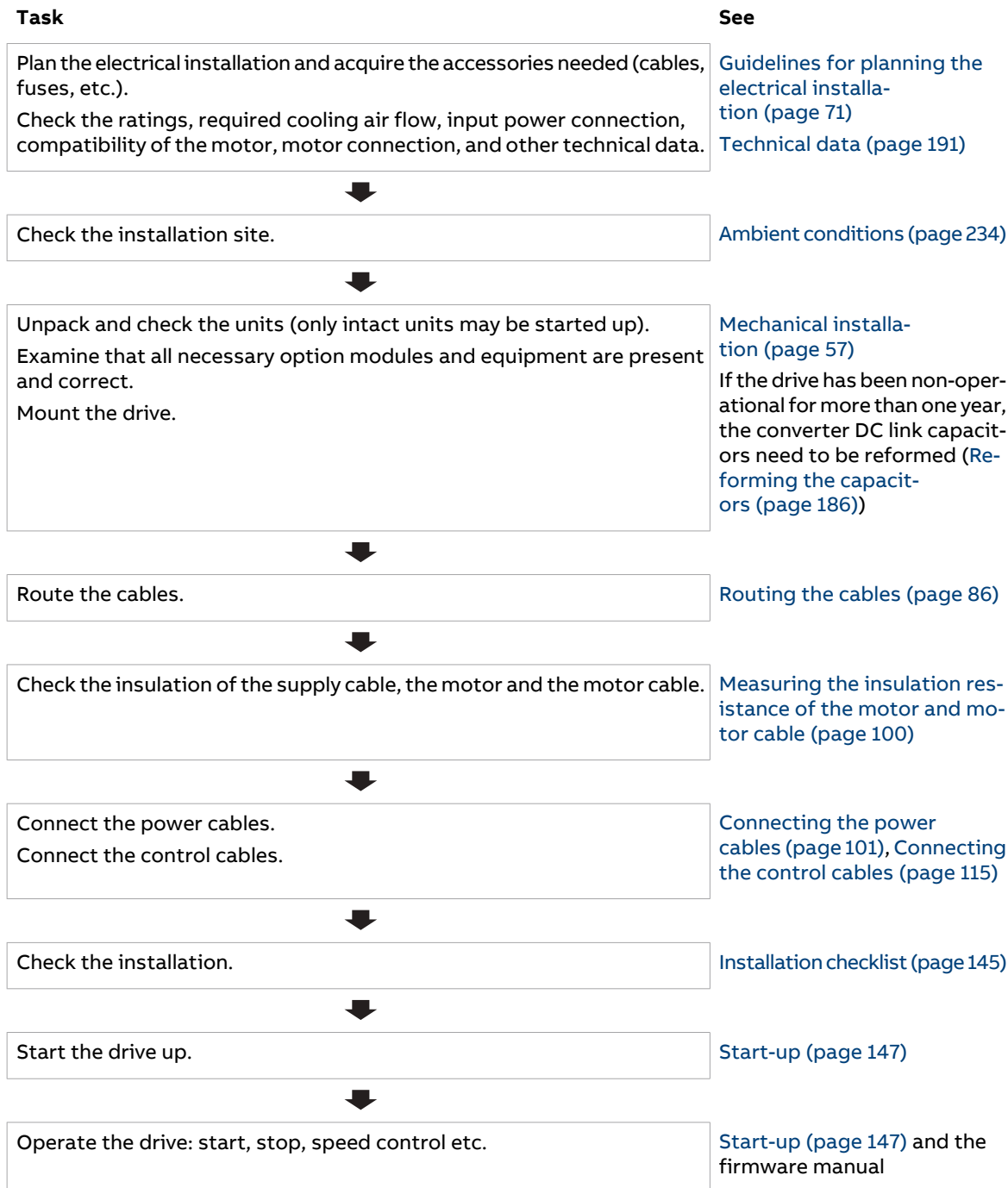

## Terms and abbreviations

| Term/<br>Abbreviation | Description   |
|-----------------------|---|
| ACH-AP-H              | Assistant control panel with Hand-Off-Auto functionality                          |
| ACH-AP-W              | Assistant control panel with Hand-Off-Auto functionality and Bluetooth interface  |
| CAIO-01               | CAIO-01 optional bipolar analog input and unipolar analog output extension module |
| CCU                   | Type of control unit  |
| CHDI-01               | 115/230 V digital input extension module  |
| CMOD-01               | Multifunction extension module (external 24 V AC/DC and digital I/O extension)    |

| Term/<br>Abbreviation | Description   |
|-----------------------|---|
| CMOD-02               | Multifunction extension module (external 24 V AC/DC and isolated PTC interface)                 |
| EMC                   | Electromagnetic compatibility   |
| EMI                   | Electromagnetic interference  |
| FBIP-21               | BACnet/IP adapter module  |
| FCAN                  | Optional CANopen® adapter module  |
| FDCO-01               | DDCS communication module with two pairs of 10 Mbit/s DDCS channels                             |
| FDNA-01               | Optional DeviceNet™ adapter module  |
| FECA-01               | Optional EtherCAT® adapter module   |
| FEIP-21               | Optional Ethernet adapter module for EtherNet/IP™   |
| FENA-21               | Optional Ethernet adapter module for EtherNet/IP™, Modbus TCP and PROFINET IO protocols, 2-port |
| FEPL-01               | Optional Ethernet POWERLINK adapter module  |
| FMBT-21               | Optional Ethernet adapter module for Modbus TCP protocol  |
| FPBA-01               | Optional PROFIBUS DP® adapter module  |
| FPNO-21               | Optional PROFINET IO adapter module   |
| Frame, frame size     | Physical size of the drive or power module  |
| FSCA-01               | Optional RS-485 (Modbus/RTU) adapter  |
| IGBT                  | Insulated gate bipolar transistor   |
| IT system             | Type of supply network that has no (low-impedance) connection to ground. See IEC 60364-5.       |
| STO                   | Safe torque off (IEC/EN 61800-5-2)  |
| TN system             | Type of supply network that provides a direct connection to ground                              |

## Related documents

You can find manuals on the Internet. See below for the relevant code/link. For more documentation, go to [www.abb.com/drives/documents](http://www.abb.com/drives/documents).



[ACH580-07 manuals](#)





# 3

## **Operation principle and hardware description**

---

### **Contents of this chapter**

This chapter briefly describes the operation principle and construction of the drive.

---

## Product overview

The ACH580-07 is a drive module for controlling AC induction motors, synchronous reluctance motors and synchronous permanent magnet motors in open loop control.

The single-line circuit of the drive is shown below.

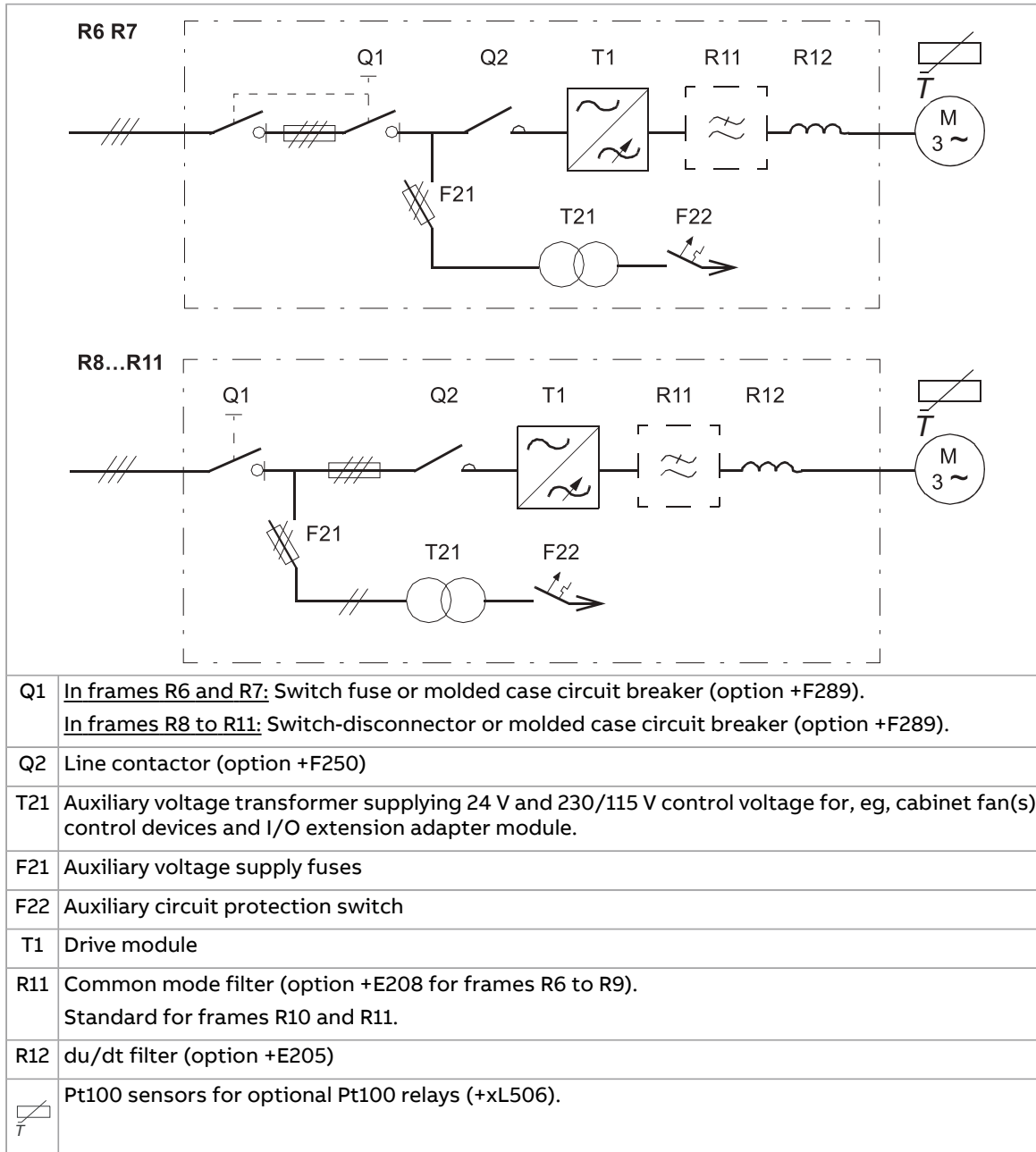

## Layout

- General information on the cabinet layout

|  |  |
|--|--|
|  |    |
| <p><b>IP21</b><br/><b>UL Type 1</b></p>  | <p><b>IP42</b><br/><b>UL Type 1 Filtered</b><br/><b>(option +B054)</b><br/><b>IP54</b><br/><b>UL Type 12</b><br/><b>(option +B055)</b></p> |

■ **Cabinet layout – R6 and R7 (bottom entry and exit of cables)**

The cabinet layout of frame R7 with du/dt filter (option +E205) is shown below. Degree of protection IP42 (UL Type 1 Filtered [option +B054]). Frame R6 looks similar.

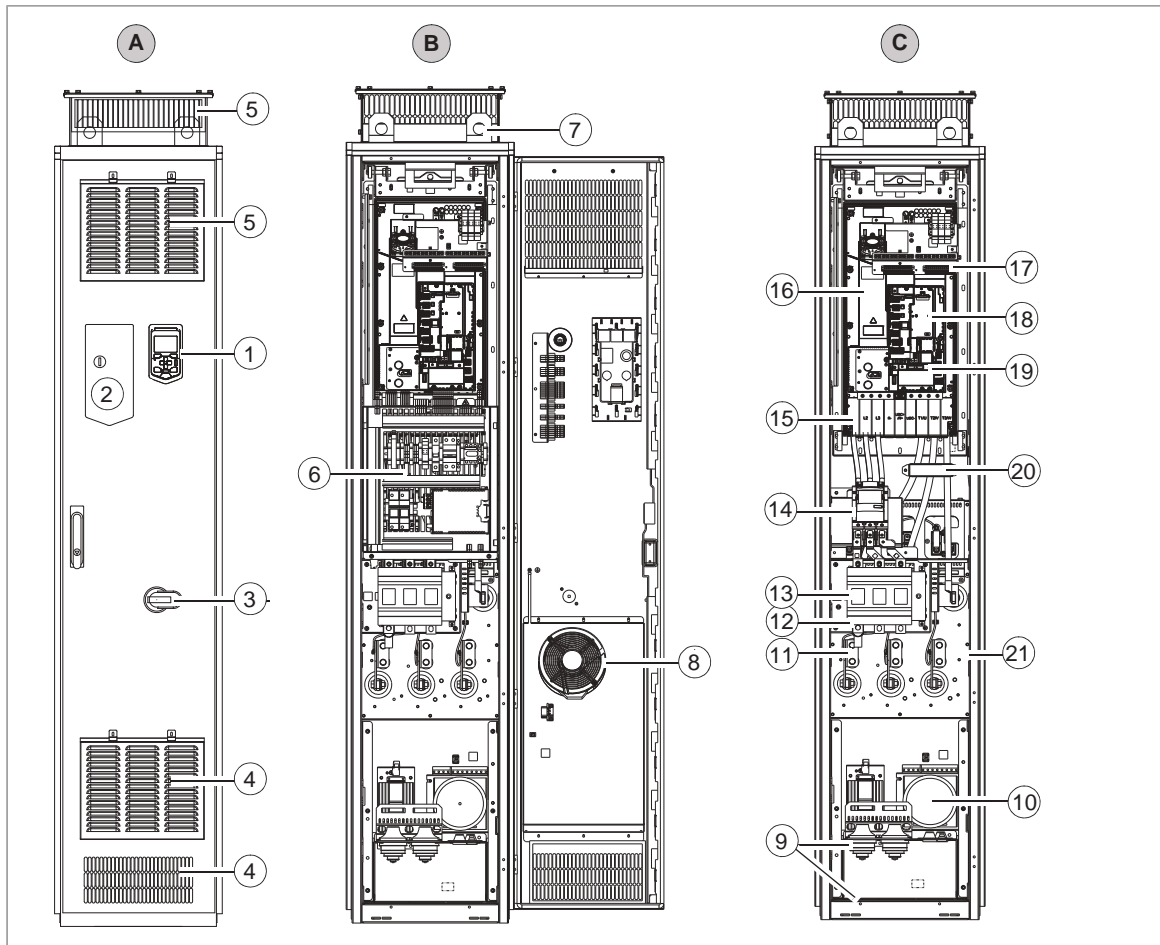

|   |   |    |  |
|---|---|----|--|
| A | Cabinet door closed   | 10 | Auxiliary voltage transformer T21  |
| B | Cabinet door open   | 11 | Motor cable connection terminals<br><b>Note:</b> For drives with no du/dt filter (option +E205), the motor cables are connected to the drive module terminals. |
| C | Cabinet door open, mounting plate and cabinet shrouds removed                   | 12 | Input cable connection terminals   |
| 1 | Drive control panel   | 13 | Main switch with AC fuses (Q1)   |
| 2 | Operating switch  | 14 | Main contactor (Q2, option +F250)  |
| 3 | Main switch handle  | 15 | Power cable connection terminals of the drive module behind the shroud   |
| 4 | Gratings for cooling air in   | 16 | Drive module   |
| 5 | Gratings for cooling air out  | 17 | Additional I/O terminal block (option +L504)   |
| 6 | Mounting plate, see section <a href="#">Mounting plate – R6 to R9 (page 36)</a> | 18 | Drive control unit   |
| 7 | Lifting lugs  | 19 | NETA-21 (not shown) (option +K496 and +K497)   |
| 8 | Cabinet door fan  | 20 | Common mode filter (option +E208)  |
| 9 | Power and control cable entries   | 21 | du/dt filter (option +E205)  |



■ Cabinet layout – R6 and R7 (top entry and exit of cables, options +H351 and +H353)

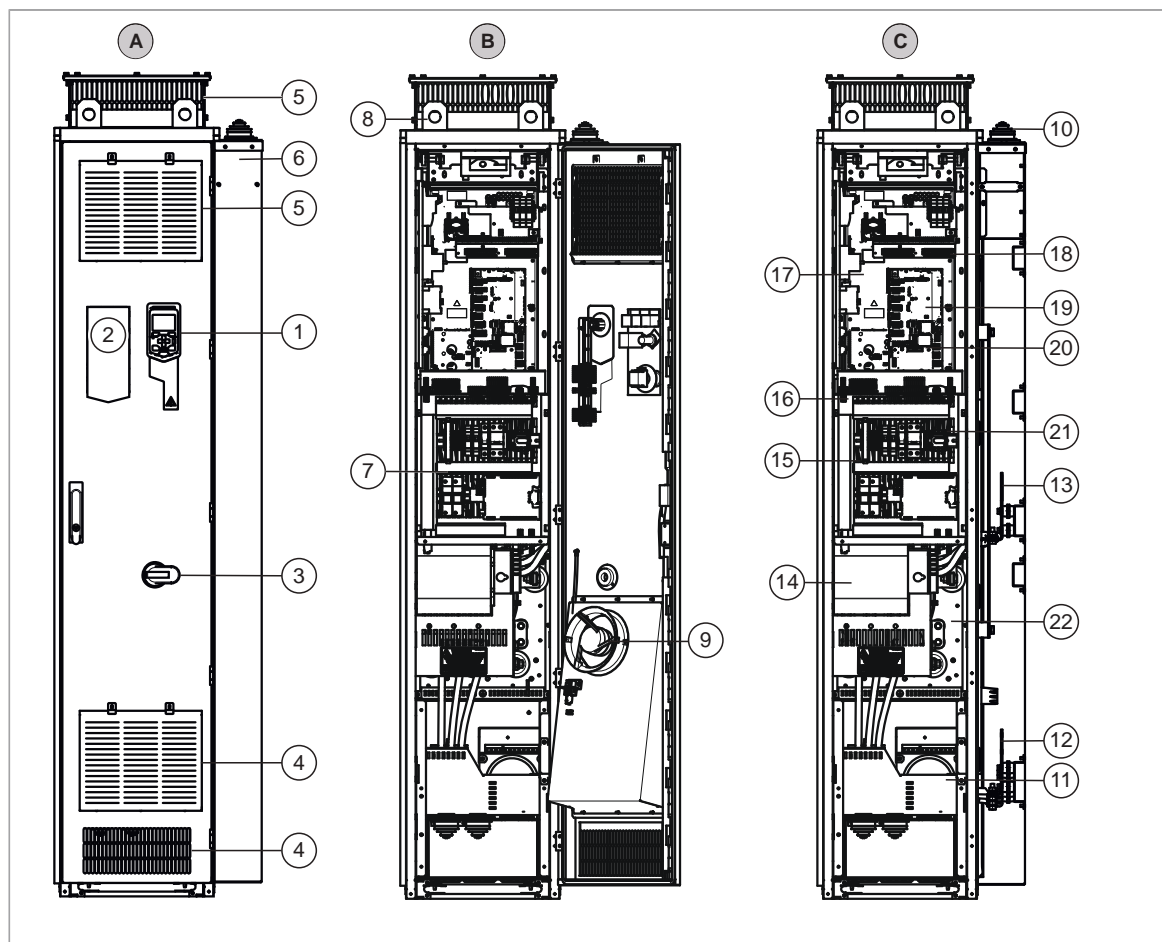

|    |   |    |  |
|----|---|----|--|
| A  | Cabinet door closed   | 11 | Auxiliary voltage transformer T21                                      |
| B  | Cabinet door open   | 12 | Motor cable connection terminals                                       |
| C  | Cabinet door open and motor cable cubicle cover removed                         | 13 | Input cable connection terminals                                       |
| 1  | Drive control panel   | 14 | Main switch with AC fuses (Q1)   |
| 2  | Operating switch  | 15 | Main contactor (Q2, option +F250) behind the mounting plate            |
| 3  | Main switch handle  | 16 | Power cable connection terminals of the drive module behind the shroud |
| 4  | Gratings for cooling air in   | 17 | Drive module   |
| 5  | Gratings for cooling air out  | 18 | Additional I/O terminal block (option +L504)                           |
| 6  | Cubicle for cabling   | 19 | Drive control unit   |
| 7  | Mounting plate, see section <a href="#">Mounting plate – R6 to R9 (page 36)</a> | 20 | NETA-21 (not shown) (option +K496 and +K497)                           |
| 8  | Lifting lugs  | 21 | Common mode filter (option +E208) behind the mounting plate            |
| 9  | Cabinet door fan  | 22 | du/dt filter (option +E205)  |
| 10 | Power and control cable entries   | -  | -  |

■ **Cabinet layout – R8 and R9 (bottom entry and exit of cables)**

The cabinet layout of frame R9 with du/dt filter (option +E205) is shown below. Degree of protection IP42 (UL Type 1 Filtered [option +B054]). Frame R8 looks similar.

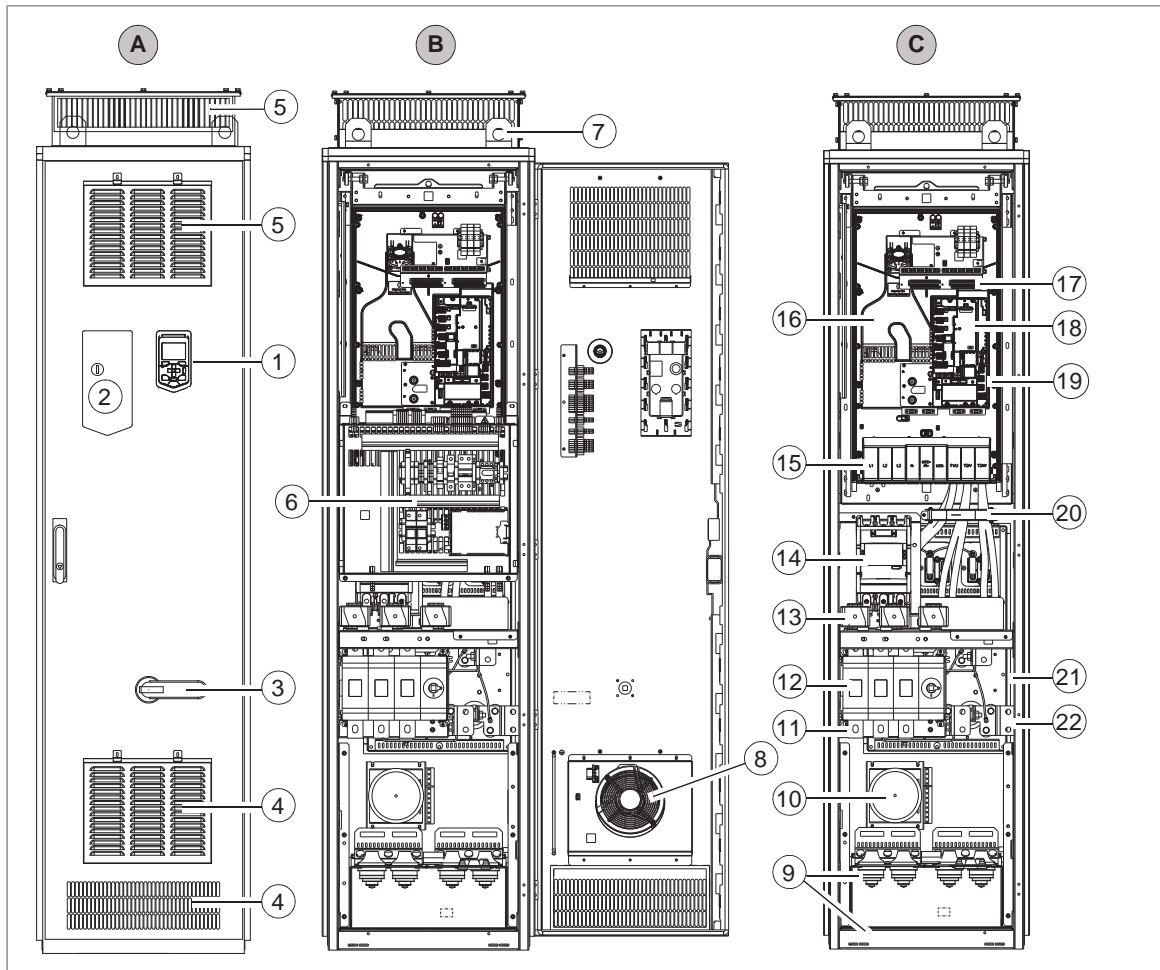

|    |   |    |  |
|----|---|----|--|
| A  | Cabinet door closed   | 11 | Input cable connection terminals                                       |
| B  | Cabinet door open   | 12 | Main switch-disconnector (Q1)  |
| C  | Cabinet door open, mounting plates and cabinet shrouds removed                  | 13 | AC fuses   |
| 1  | Drive control panel   | 14 | Main contactor (Q2, option +F250)                                      |
| 2  | Operating switch  | 15 | Power cable connection terminals of the drive module behind the shroud |
| 3  | Main switch handle  | 16 | Drive module   |
| 4  | Gratings for cooling air in   | 17 | Additional I/O terminal block (option +L504)                           |
| 5  | Gratings for cooling air out  | 18 | Drive control unit   |
| 6  | Mounting plate, see section <a href="#">Mounting plate – R6 to R9 (page 36)</a> | 19 | NETA-21 (not shown) (option +K496 and +K497)                           |
| 7  | Lifting lugs  | 20 | Common mode filter (option +E208)                                      |
| 8  | Cabinet door fan  | 21 | du/dt filter (option +E205)  |
| 9  | Power and control cable entries   | 22 | Motor cable connection terminals                                       |
| 10 | Auxiliary voltage transformer T21   | -  | -  |

**Note:** For drives with no du/dt filter (option +E205), the motor cables are connected to the drive module terminals.

■ Cabinet layout – R8 and R9 (top entry and exit of cables, options +H351 and +H353)

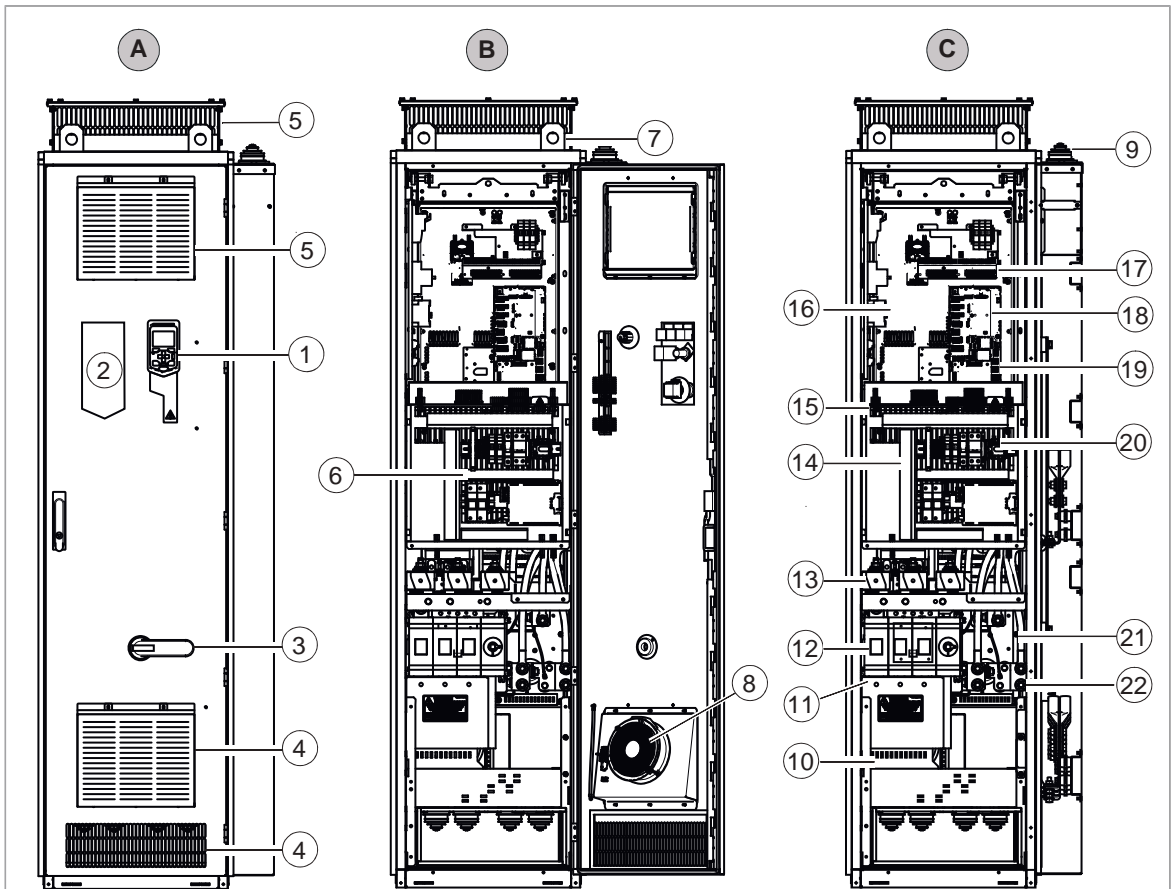

|    |   |    |  |
|----|---|----|--|
| A  | Cabinet door closed   | 11 | Input cable connection terminals                                       |
| B  | Cabinet door open   | 12 | Main switch-disconnector (Q1)  |
| C  | Cabinet door open, mounting plates and cabinet shrouds removed                  | 13 | AC fuses   |
| 1  | Drive control panel   | 14 | Main contactor (Q2, option +F250)                                      |
| 2  | Operating switch  | 15 | Power cable connection terminals of the drive module behind the shroud |
| 3  | Main switch handle  | 16 | Drive module   |
| 4  | Gratings for cooling air in   | 17 | Additional I/O terminal block (option +L504)                           |
| 5  | Gratings for cooling air out  | 18 | Drive control unit   |
| 6  | Mounting plate, see section <a href="#">Mounting plate – R6 to R9 (page 36)</a> | 19 | NETA-21 (not shown) (option +K496 and +K497)                           |
| 7  | Lifting lugs  | 20 | Common mode filter (option +E208)                                      |
| 8  | Cabinet door fan  | 21 | du/dt filter (option +E205)  |
| 9  | Power and control cable entries   | 22 | Motor cable connection terminals                                       |
| 10 | Auxiliary voltage transformer T21   | -  | -  |

**Note:** For drives with no du/dt filter (option +E205), the motor cables are connected to the drive module terminals.

■ **Mounting plate – R6 to R9**

The components and terminals on the mounting plate of frames R6 to R9 are shown below.

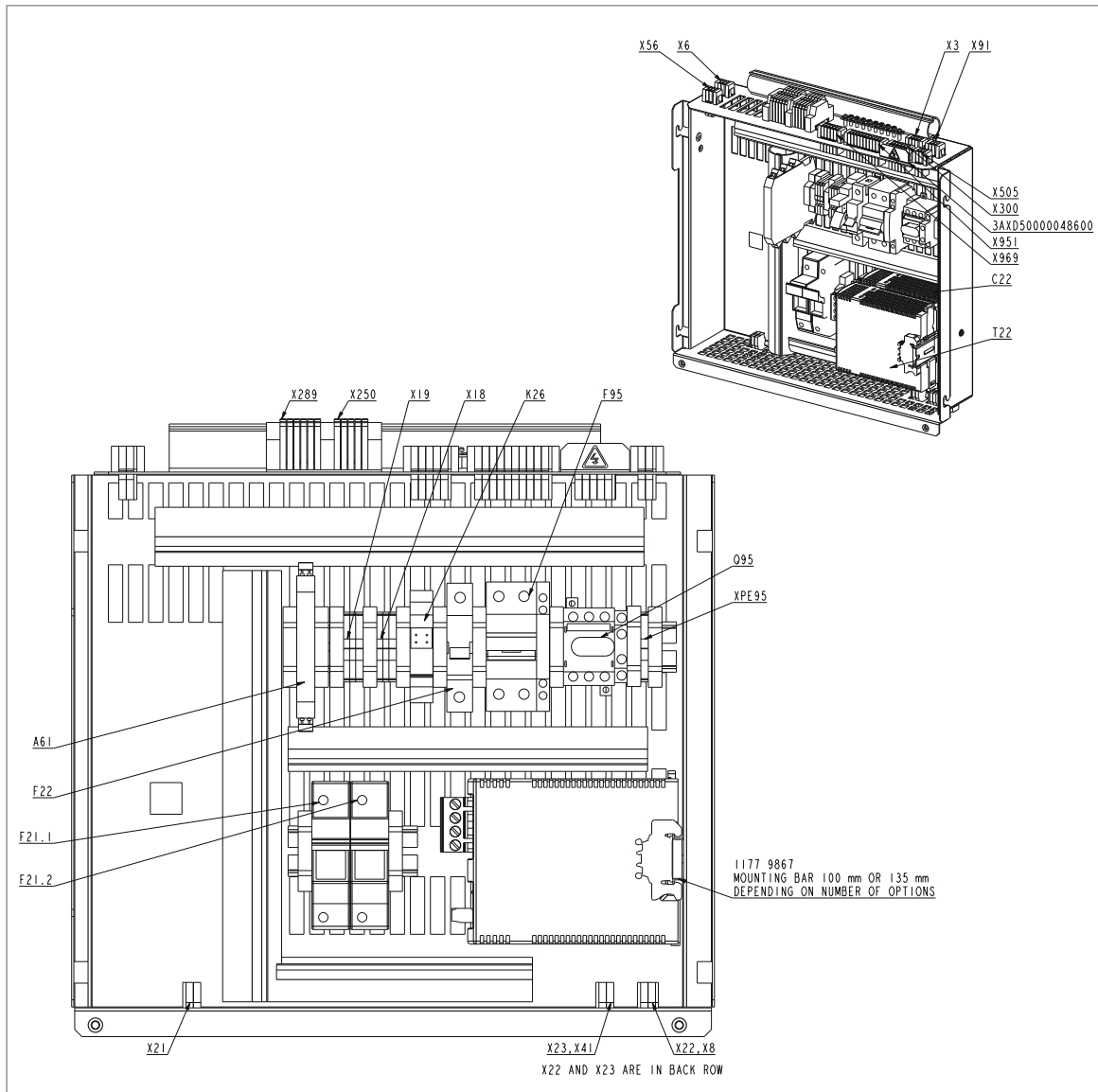

|  |   |      |  |
|--|---|------|--|
| +G300  | Switch-disconnector and miniature circuit breaker for cabinet heater (option +G300)                                   | X3   | External main contactor control  |
| A61  | Emergency stop relay for options +Q951 and +Q963  | X250 | Indication of main contactor status  |
| Q95, F95   | Switch-disconnector and miniature circuit breaker for cabinet heater (option +G300)                                   | X289 | Indication of the status of the molded case circuit breaker (option +F289) |
| F21  | Auxiliary transformer fuses   | X300 | Connection terminals for cabinet heater (option +G300)                     |
| F22  | Auxiliary transformer's secondary side miniature circuit breaker  | X951 | Connection of external emergency stop button (options +Q951 and Q963)      |
| T22, C22   | 24VDC power supply and buffer with emergency stop options (+Q951 and +Q963), also with line contactor option (+F250). | X969 | Connection of external Safe torque off button                              |
| X251, X4, X6, X56, X53, X51, X55, X18 and X19: for internal use. |   |      |  |

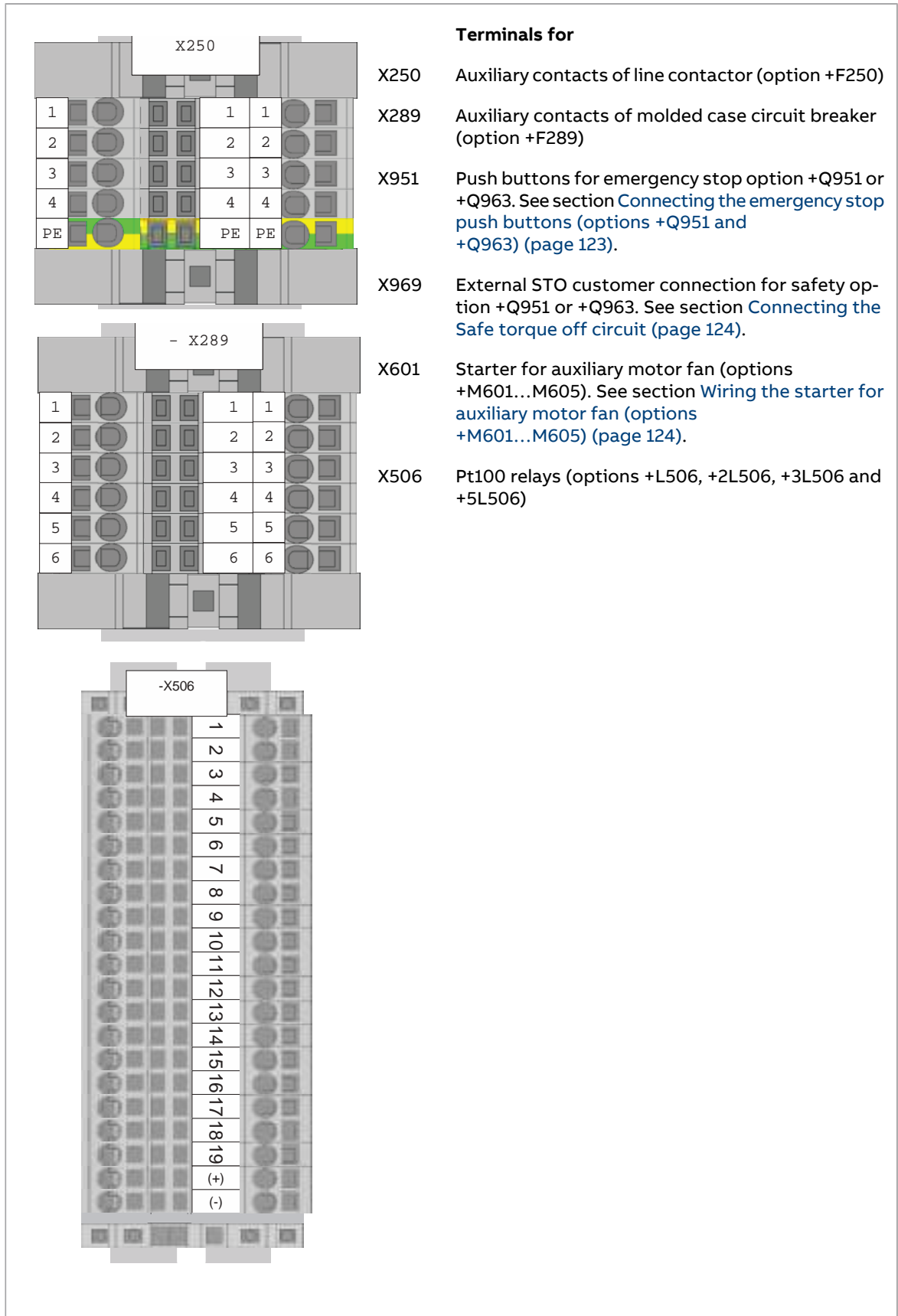

■ **Cabinet layout – R10 and R11 (bottom entry and exit of cables)**

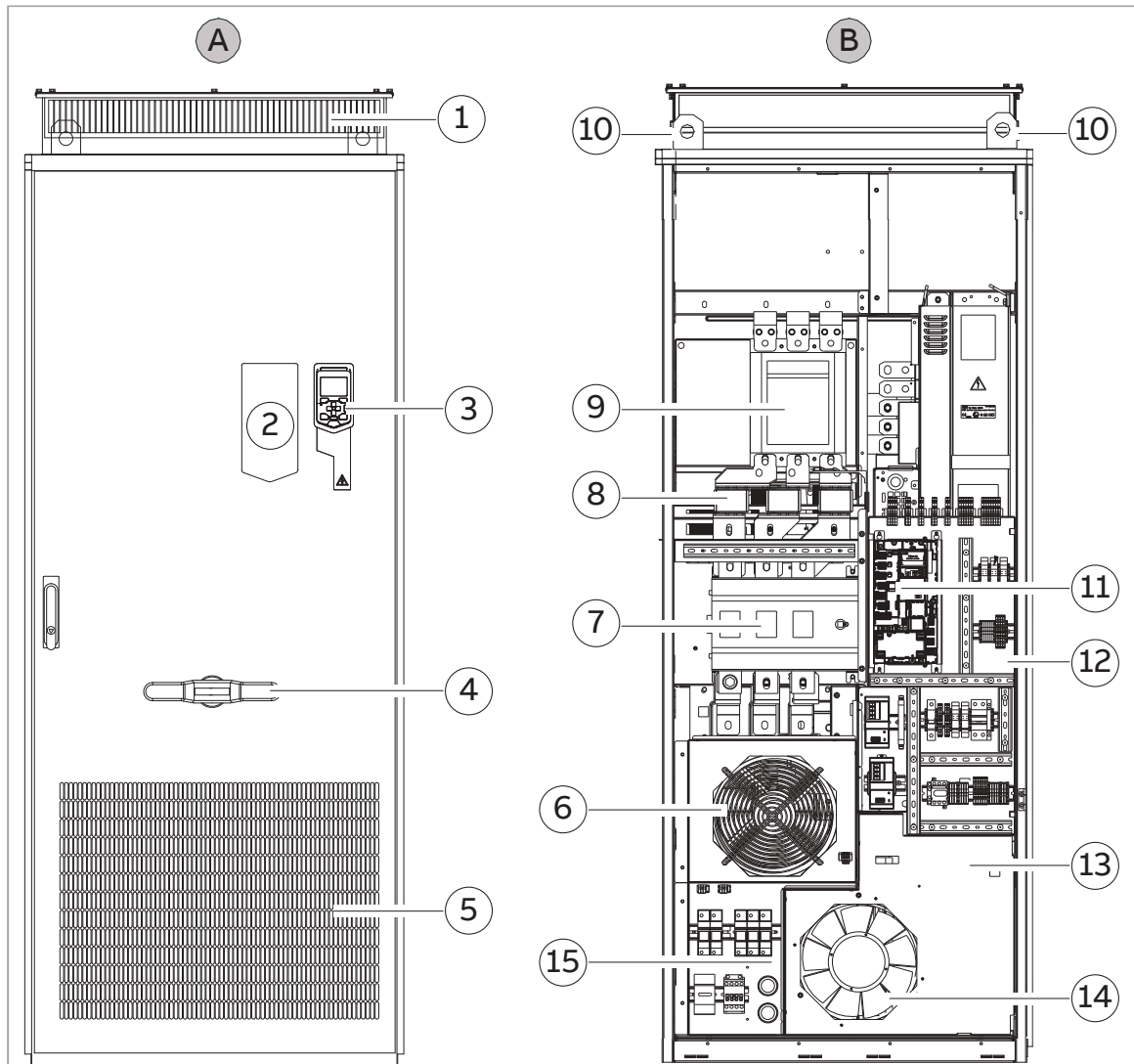

|   |   |    |  |
|---|---|----|--|
| A | Cabinet door closed                           | 8  | AC fuses   |
| B | Cabinet door open                             | 9  | Line contactor (option +F250)  |
| 1 | Gratings for cooling air out                  | 10 | Lifting lugs   |
| 2 | Operating switch                              | 11 | Drive control unit   |
| 3 | Drive control panel                           | 12 | Mounting plate, see section <a href="#">Mounting plate – R10 and R11 (page 41)</a> |
| 4 | Main switch handle                            | 13 | Behind the shroud: Additional I/O terminal block (option +L504)                    |
| 5 | Gratings for cooling air in                   | 14 | Additional fan in IP54 cabinets (option +B055)                                     |
| 6 | "Door" fan at the back of the mounting plate. | 15 | NETA-21 (not shown) (option +K496 and +K497)                                       |
| 7 | Main switch-disconnector                      | -  | -  |

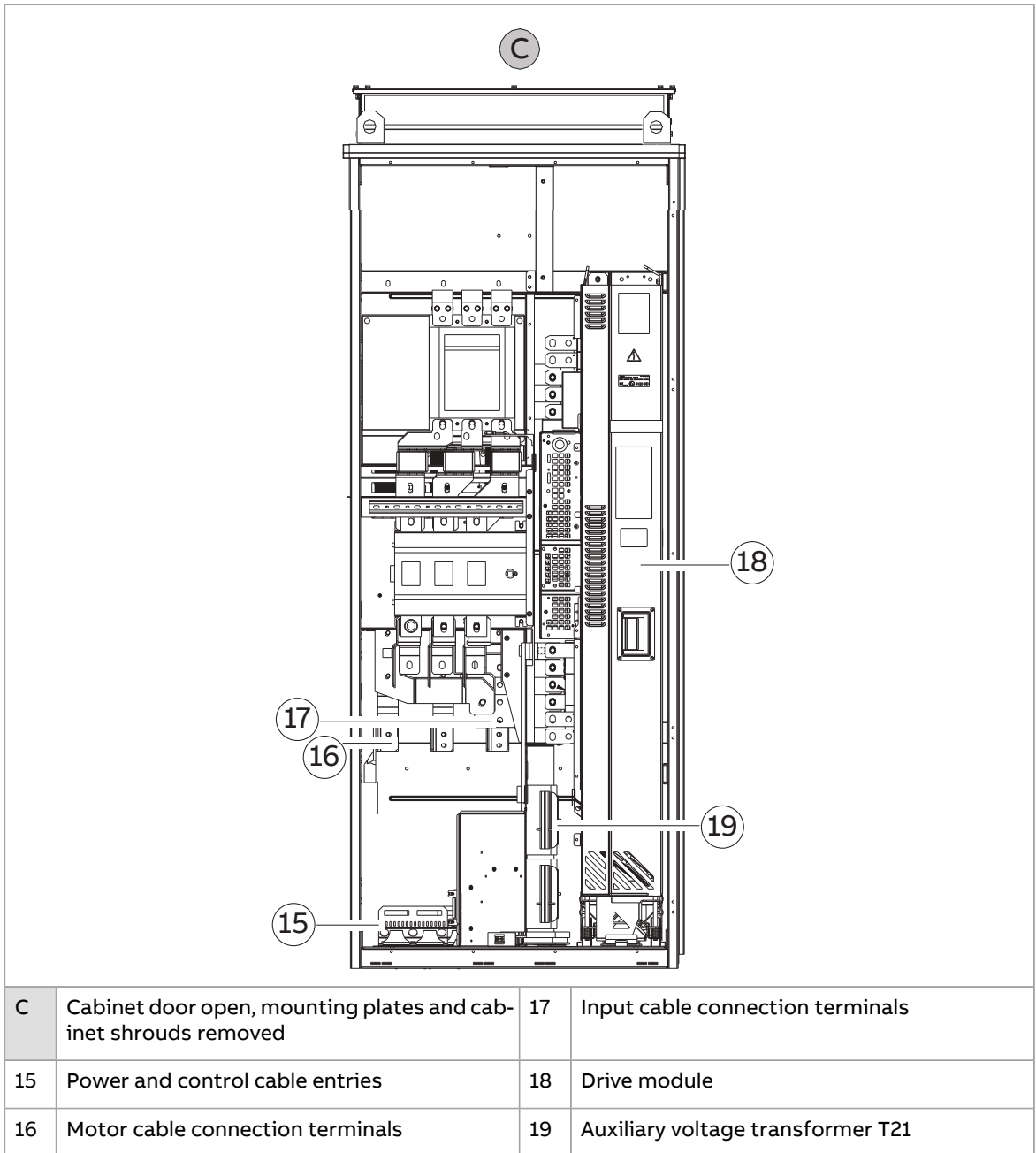

■ **Cabinet layout – R10 and R11 (top entry and exit of cables, options +H351 and +H353)**

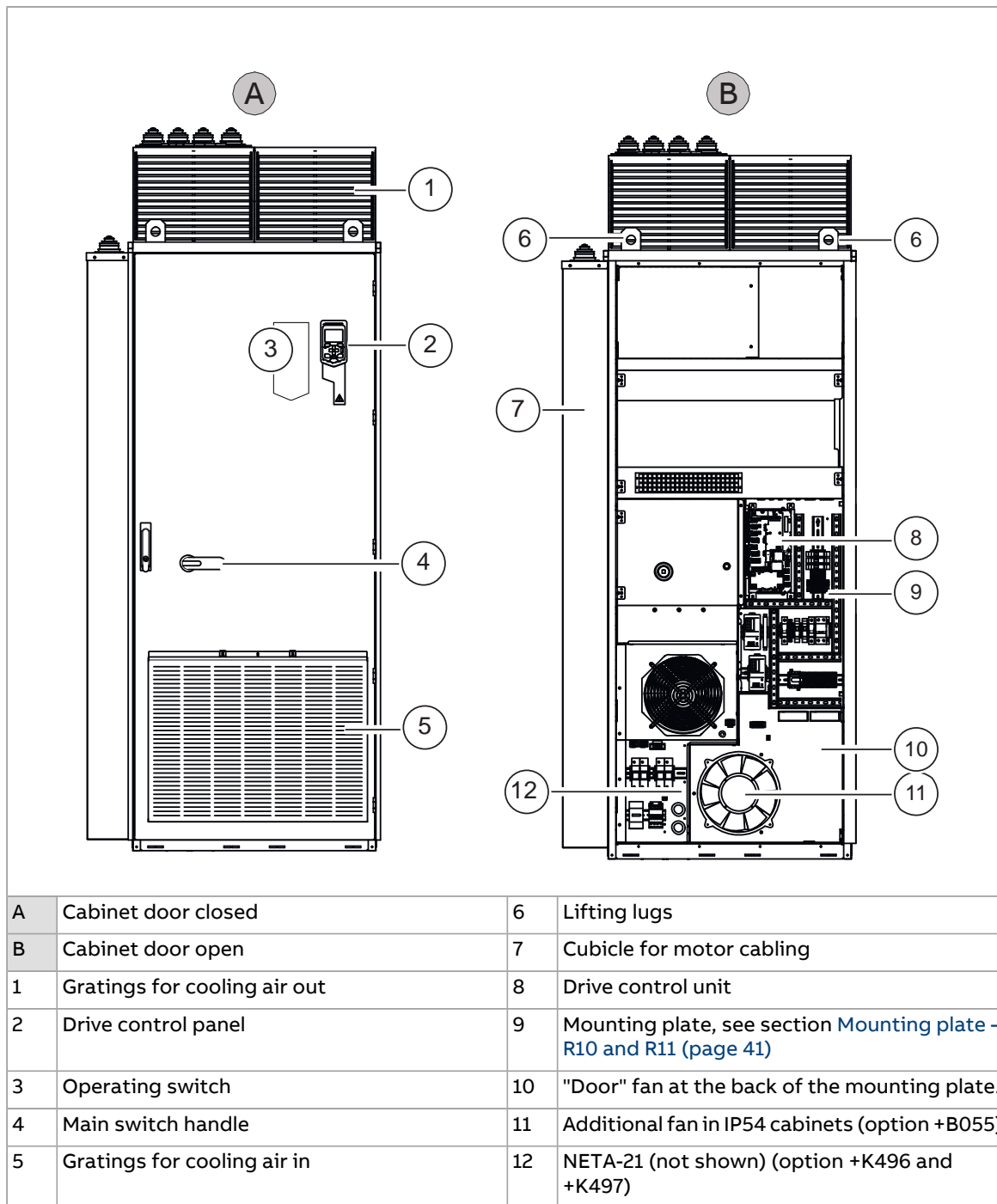



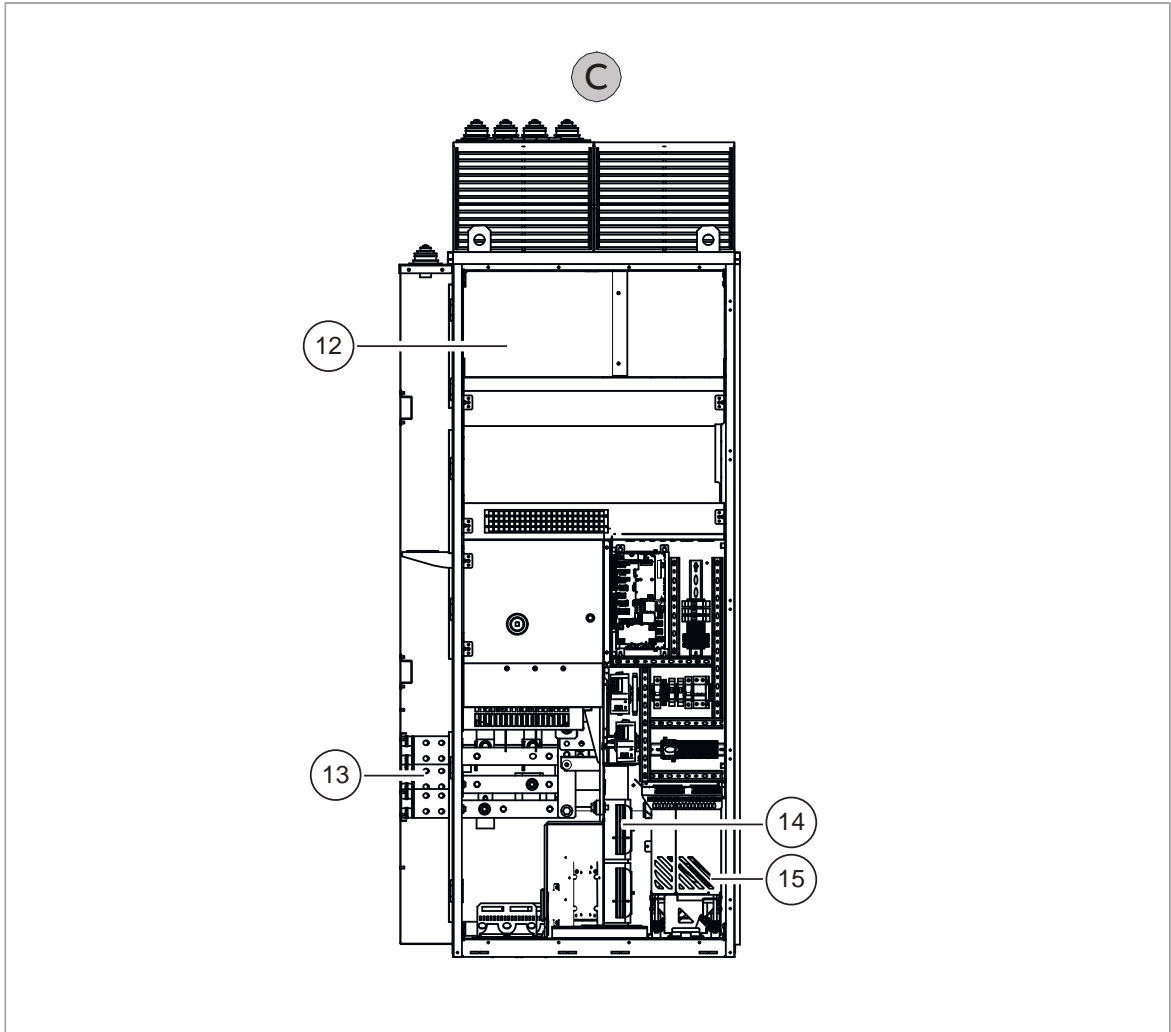

|    |  |    |                                   |
|----|--|----|-----------------------------------|
| C  | Cabinet door open, lower shrouds and motor cable cubicle cover removed | 14 | Auriliary voltage transformer T21 |
| 12 | Input cable connection terminals behind the shroud                     | 15 | Drive module                      |
| 13 | Motor cable connection terminals                                       | -  | -                                 |

■ **Mounting plate – R10 and R11**

The components and terminals on the mounting plate of frames R10 and R11 are shown below.

## 42 Operation principle and hardware description

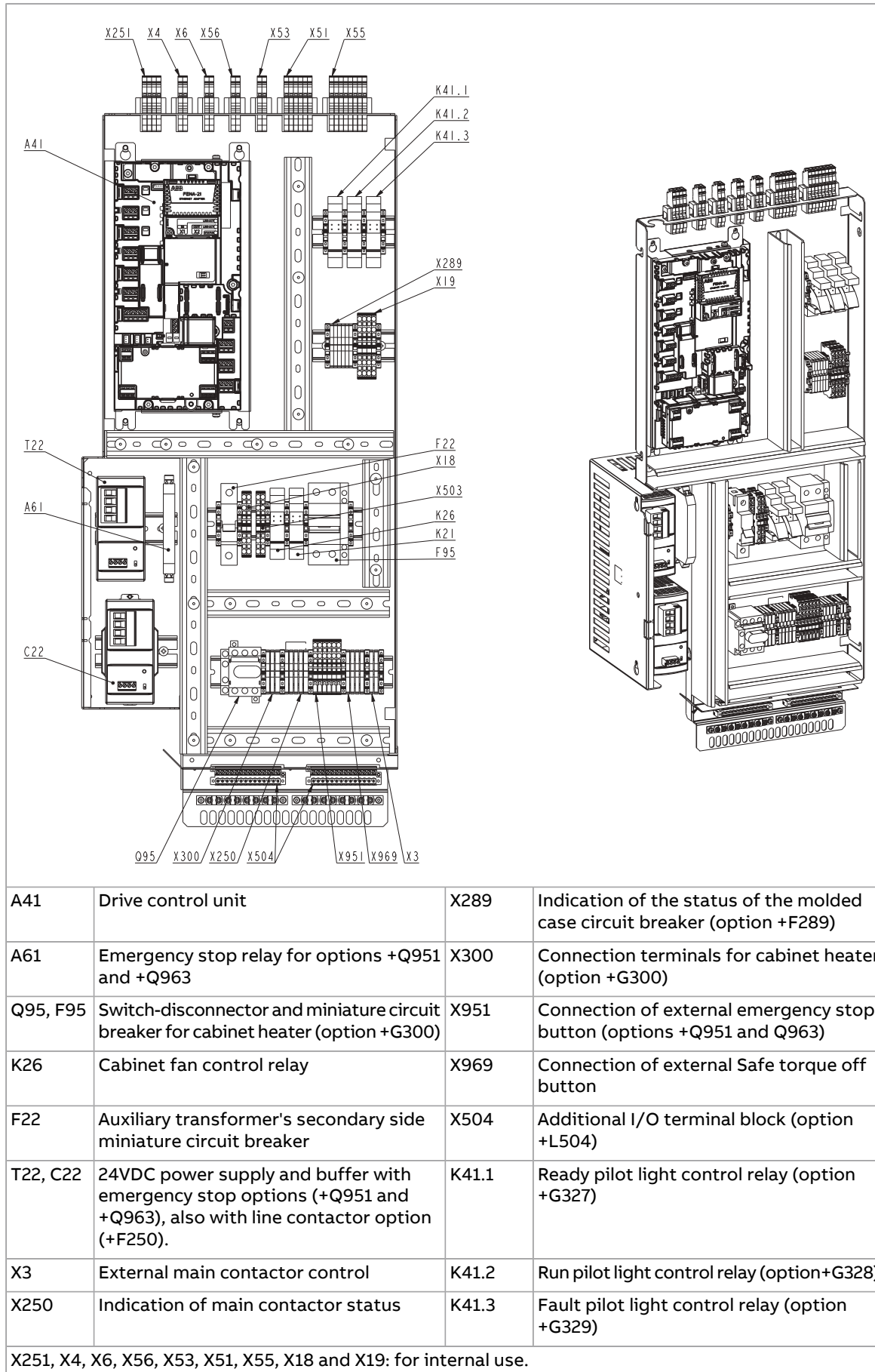

■ **Cooling air flow**

The figures below show cooling air flow trough the cabinet.

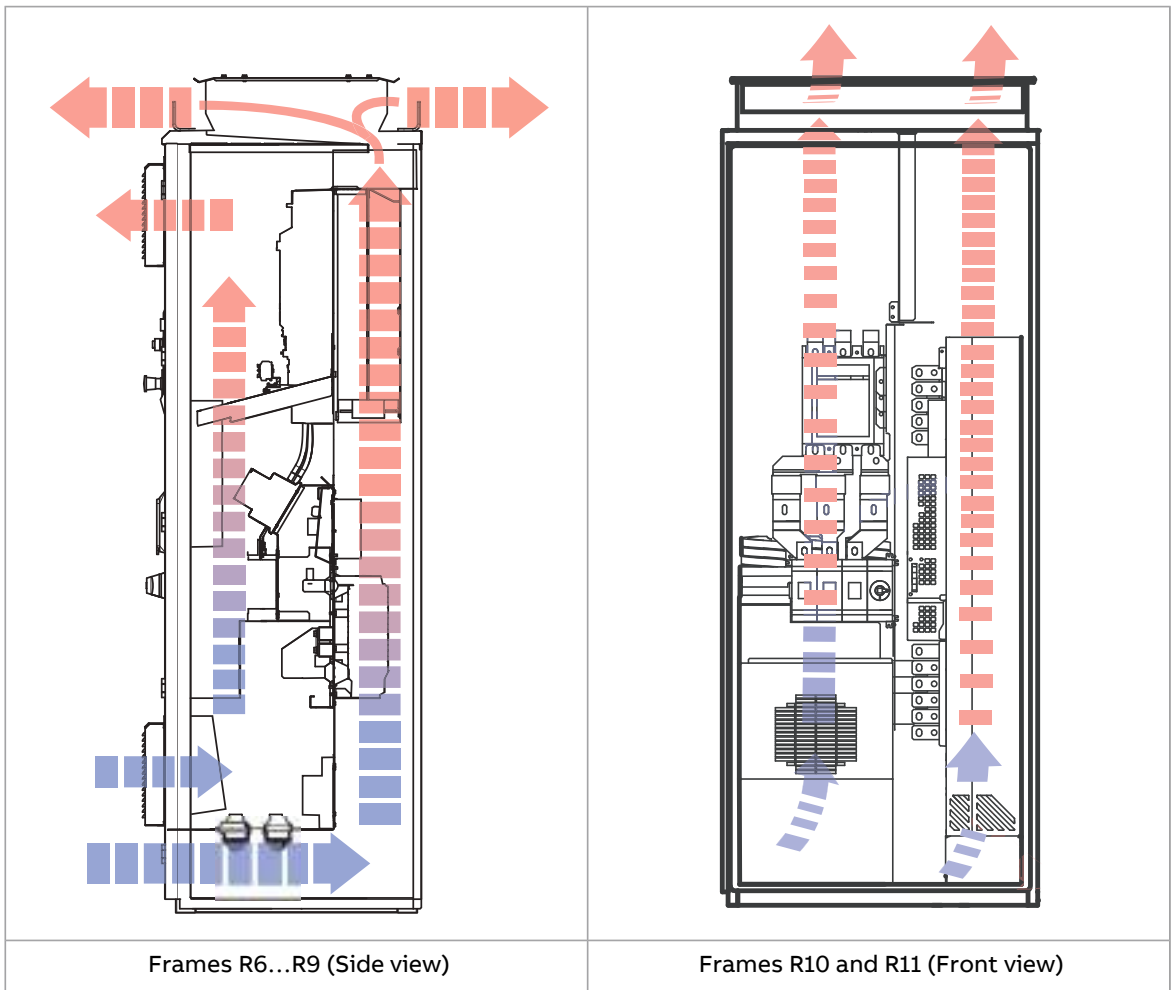

■ **Door switches and lights**



|   | Label in English  | Label in local language | Description  |   |  |   |                                |
|---|---|-------------------------|--|---|--|---|--------------------------------|
| 1 | READY   | -                       | Ready pilot light (option +G327)   |   |  |   |                                |
| 2 | RUN   | -                       | Run pilot light (option+G328)  |   |  |   |                                |
| 3 | FAULT   | -                       | Fault pilot light (option +G329)   |   |  |   |                                |
| 4 | MAIN CONTACTOR<br>OFF ON<br> | -                       | Operating switch with option +F250<br><table border="1" style="width: 100%;"> <tr> <td>0</td> <td>Opens the main contactor (Q2) and disables starting of the drive</td> </tr> <tr> <td>1</td> <td>Closes the main contactor (Q2)</td> </tr> </table> | 0 | Opens the main contactor (Q2) and disables starting of the drive | 1 | Closes the main contactor (Q2) |
| 0 | Opens the main contactor (Q2) and disables starting of the drive  |                         |  |   |  |   |                                |
| 1 | Closes the main contactor (Q2)  |                         |  |   |  |   |                                |
| 5 | EMERGENCY STOP<br>RESET   | -                       | Emergency stop indication light and reset push button with options +Q951 and +Q963   |   |  |   |                                |
| 6 | EMERGENCY STOP  | -                       | Emergency stop push button with options +Q951 and +Q963  |   |  |   |                                |

**Main switch-disconnector Q1**

The switch-disconnector handle switches the main voltage to the drive on and off.

■ **Control panel**

The control panel is the user interface of the drive. It provides the essential controls such as Start/Stop/Direction/Reset/Reference, and the parameter settings for the control program.

One control panel can be used to control several drives through a panel link.

The control panel can be removed by pulling it forward from the top edge and disconnecting the panel cable. The panel is reinstalled in reverse order. For the use of the control panel, see the firmware manual or *ACS-AP-I, -S, -W and ACH-AP-H, -W Assistant control panels user's manual* ([3AUA0000085685](#) [English]).



### Control by PC tools

There is a USB connector on the front of the panel that can be used to connect a PC to the drive. When a PC is connected to the control panel, the control panel keypad is disabled.

#### ■ Common mode filter

The drive of frames R6 to R9 can be optionally equipped with a common mode filter (option +E208). Frames R10 and R11 are equipped with a common mode filter as standard. The filter contains ferrite rings mounted around the drive AC conductors. The filter protects the motor bearings by reducing the bearing currents.

More information on when the option is required: See section [Examining the compatibility of the motor and drive \(page 72\)](#).

## Overview of power and control connections

This diagram shows the power connections and control interfaces of the drive frames R6...R11.

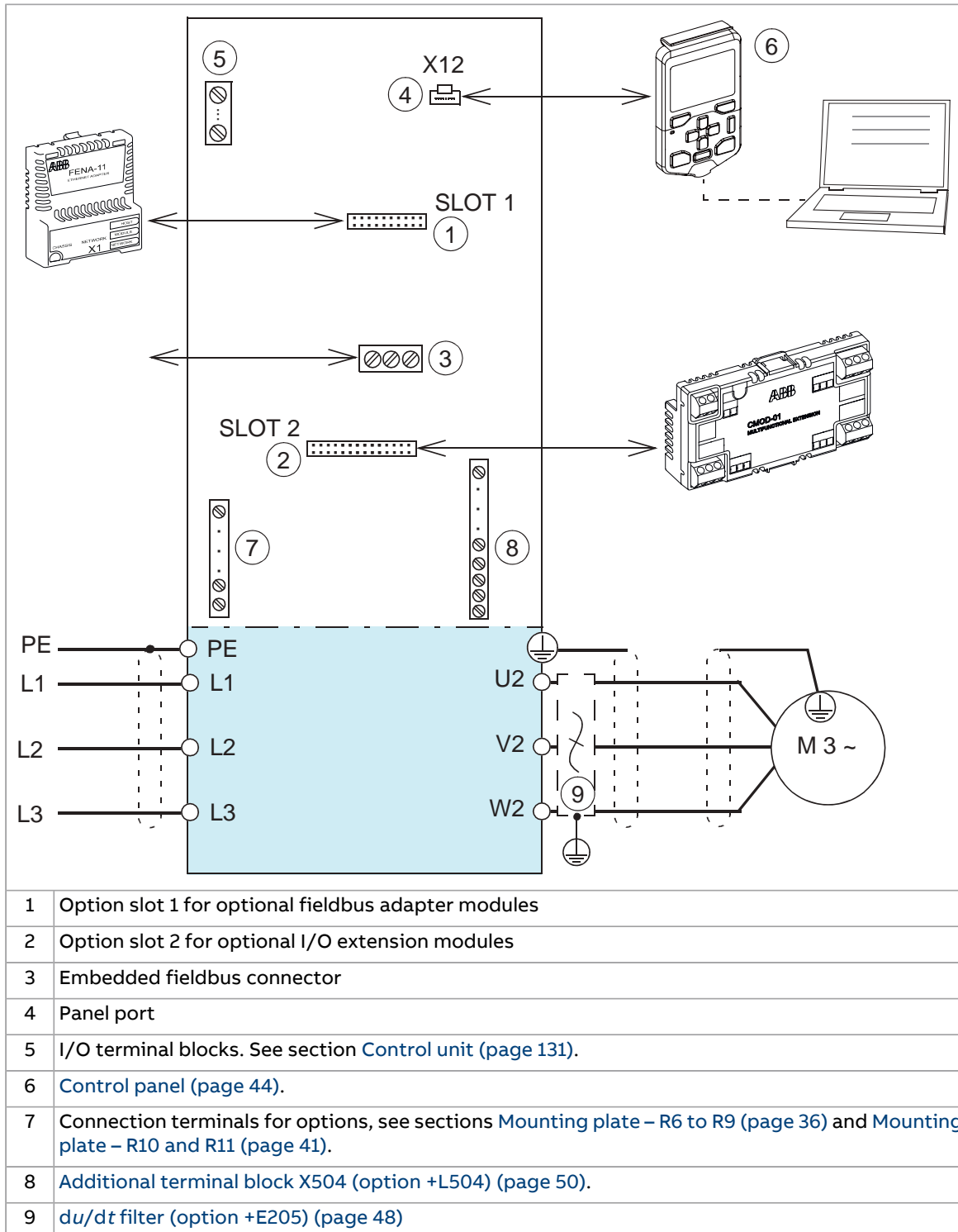

## Descriptions of options

**Note:** All options are not available for all drive types, are not compatible with some other options, or require additional engineering.

## ■ Degree of protection

### Definitions

According to IEC/EN 60529, the degree of protection is indicated by an IP code where the first numeral means protection against ingress of solid foreign objects, and the second numeral protection against ingress of water. The IP codes of the standard cabinet and options covered in this manual are defined below.

| IP code | The equipment is protected ...                               |   |
|---------|--|---|
|         | First numeral  | Second numeral                              |
| IP21    | against ingress of solid foreign objects > 12.5 mm diameter* | against dripping (vertically falling drops) |
| IP42    | against ingress of solid foreign objects > 1 mm              | against dripping (15° tilting) water        |
| IP54    | dust-protected   | against splashing water                     |

\* meaning for protection of persons: against access to hazardous parts with finger

### IP21 (UL Type 1)

The degree of protection of the standard drive cabinet is IP21 (UL type 1). The air outlets at the top of the cabinet and the air inlet gratings are covered with metallic gratings. With doors open, the degree of protection of the standard cabinet and all cabinet options is IP20. The live parts inside the cabinet are protected against contact with clear plastic shrouds or metallic gratings.

### IP42 (UL Type 1 Filtered) (option +B054)

This option provides the degree of protection of IP42 (UL type 1). The air inlet gratings are covered with a metallic mesh between the inner and outer metallic gratings.

### IP54 (UL Type 12) (Standard)

This option provides the degree of protection of IP54 (UL type 12). It provides the cabinet air inlets with filter housings containing folded board air filter mats between the inner and outer metallic gratings. An additional fan and filtered outlets on the cabinet roof are also included.

## ■ Cooling air inlet through bottom of cabinet (option +C128)

See section [Air inlet through the bottom of the cabinet \(option +C128\) \(page 68\)](#).

## ■ UL Listed (option +C129)

The cabinet contains the following accessories and features:

- top entry and exit with US cable conduit entries (plain plate without ready-made holes)
- all components UL/CSA Listed/Recognized
- maximum supply voltage 480 V
- US-type main switch and fuses.

## ■ Channeled air outlet (option +C130)

This option provides a collar for connection to an air outlet duct. The collar is located on the cabinet roof. Depending on the equipment installed in each cubicle, the channeled air outlet either replaces, or adds to, the standard roof arrangement.

---

With option +B055, this option also provides the cabinet air inlets with filter housings containing folded board air filter mats between the inner and outer metallic gratings.

See also section [Air outlet duct on the cabinet roof \(option +C130\) \(page 69\)](#).

#### ■ **Plinth height (options +C164 and +C179)**

The standard height of the cabinet plinth is 50 mm. These options specify a plinth height of 100 mm (+C164) or 200 mm (+C179).

#### ■ **Empty cubicles on right (options +C196...C198)**

The option adds an empty 400, 600 or 800 mm wide cubicle to the right end of the line-up. The cubicle is equipped with blank power cable entries both at the top and the bottom.

The cubicle is equipped with blank panel entries (two-half panels) on both the side and back.

#### ■ **Empty cubicles on left (options +C199...C201)**

The option adds an empty 400, 600 or 800 mm wide cubicle to the left end of the line-up. The cubicle is equipped with blank power cable entries both at the top and the bottom.

The cubicle is equipped with blank panel entries (two-half panels) on both the side and back.

#### ■ **EMC filter (option +E202)**

EMC filter for 1st Environment (category C2) for TN (grounded) system.

Option +E202 is not available with options +H351 and +H353.

#### ■ **du/dt filter (option +E205)**

The du/dt filter protects the motor insulating system by reducing the voltage rise speed at the motor terminals. The filter also protects the motor bearings by reducing the bearing currents.

More information on when the option is required: See section [Examining the compatibility of the motor and drive \(page 72\)](#).

#### ■ **Common mode filter (option +E208)**

The common mode filter contains ferrite rings mounted around the AC output busbars in the drive module. The filter protects the motor bearings by reducing the bearing currents.

More information on when the option is required: See section [Examining the compatibility of the motor and drive \(page 72\)](#).

#### ■ **Molded case circuit breaker (MCCB, option +F289)**

This option replaces the standard main switch with a molded case circuit breaker. The breaker has built-in protection functions against overload and short-circuit. It is operated with a direct rotary handle on the cabinet door.

For North American market only.

---



### ■ Cabinet heater with external supply (option +G300)

The option contains:

- heating elements in the cubicles or supply/inverter modules
- load switch for providing electrical isolation during service
- miniature circuit breaker for overcurrent protection
- terminal block for external power supply.

The heater prevents condensation inside the cabinet when the drive is not in operation. The power output of the heating elements increases when the surrounding air temperature is low and decreases when the surrounding air temperature is high. The customer must stop the heating when it is not needed by disconnecting the heater supply voltage.

The customer must supply the heater from an external 110...240 V AC power source.

For the actual wiring, see the circuit diagrams delivered with drive.

### ■ Terminals for external control voltage (option +G307)

The option provides terminals for connecting an external uninterruptible control voltage to the control unit and control devices when the drive is not powered.

See also:

- [Supplying power for the auxiliary circuits \(page 95\)](#)
- circuit diagrams delivered with drive for the actual wiring.

### ■ Output for motor space heater (option +G313)

The option contains:

- load switch for providing electrical isolation during service
- miniature circuit breaker for overcurrent protection
- terminal block for heater and external heater supply connection.

When the drive is running, the heater is switched off. Otherwise, the heater is controlled by the external supply voltage.

The power and voltage of the heater depend on the motor.

See also:

- [Supplying power for the auxiliary circuits \(page 95\)](#)
- circuit diagrams delivered with drive for the actual wiring.

### ■ Ready/Run/Fault lights (options +G327...G329)

These options provide "ready" (+G327, white), "run" (+G328, green) and "fault" (+G329, yellow) lights installed on the cabinet door.

### ■ Top cable entry/exit (options +H351 and +H353)

The top entry (+H351) and top exit (+H353) options provide power and control cable entries at the roof of the cabinet. The entries are equipped with grommets and 360° grounding hardware.

---

The options +H351 and +H353 add an additional 128 mm (5.04 in) wide cable channel to the cabinet width in frames R6...R9. Option (+H353) adds an additional 153 mm (6.02 in) to the cabinet width in frames R10 and R11.

Option +E202 is not available with options +H351 and +H353.

■ **European cable entry (option +H357)**

The standard configuration is equipped with European cable entry. This option provides European cable entry if option +C129 has been pre-selected. +H357 is not compatible with option with +H358.

■ **Cable conduit entry (option +H358)**

The option provides US/UK conduit plates (plain 3 mm thick steel plates without any ready-made holes).

■ **Connectivity for wired remote monitoring (option +K496)**

This option provides a gateway to connect the drive to ABB Ability™ via a local Ethernet network. Includes NETA-21 remote monitoring tool and FMBT-21 Modbus/TCP adapter module.

See the appropriate manual for more information.

| Manual  | Code (English)                  |
|---|---------------------------------|
| NETA-21 remote monitoring tool user's manual                            | <a href="#">3AUA0000096939</a>  |
| NETA-21 remote monitoring tool installation and start-up guide          | <a href="#">3AUA0000096881</a>  |
| FMBT-21 Modbus/TCP adapter module user's manual                         | <a href="#">3AXD50000158607</a> |
| FMBT-21 Modbus/TCP adapter module quick installation and start-up guide | <a href="#">3AXD50000158560</a> |

■ **Connectivity for wireless remote monitoring (option +K497)**

This option provides a gateway to connect the drive to ABB Ability™ via a wireless 4G network. Includes NETA-21 remote monitoring tool, FMBT-21 Modbus/TCP adapter module and modem.

See the appropriate manual for more information.

| Manual  | Code (English)                  |
|---|---------------------------------|
| NETA-21 remote monitoring tool user's manual                            | <a href="#">3AUA0000096939</a>  |
| NETA-21 remote monitoring tool installation and start-up guide          | <a href="#">3AUA0000096881</a>  |
| FMBT-21 Modbus/TCP adapter module user's manual                         | <a href="#">3AXD50000158607</a> |
| FMBT-21 Modbus/TCP adapter module quick installation and start-up guide | <a href="#">3AXD50000158560</a> |
| InRouter 615-S commissioning guide                                      | <a href="#">3AXD50000837939</a> |

■ **Additional terminal block X504 (option +L504)**

The standard terminal blocks of the drive control unit are wired to the additional terminal block at the factory for customer control wiring. The terminals are spring loaded.

**Note:** The optional modules inserted in the slots of the control unit are not wired to the additional terminal block. The customer must connect the optional module control wires directly to the modules.

Cables accepted by the terminals of the additional I/O terminal block:

- solid wire 0.2 ... 2.5 mm<sup>2</sup> (24...12 AWG)
- stranded wire with ferrule 0.25 ... 2.5 mm<sup>2</sup> (24...12 AWG)
- stranded wire without ferrule 0.2 ... 2.5 mm<sup>2</sup> (24...12 AWG).

### ■ Thermal protection with Pt100 relays (option +nL506)

Pt100 temperature monitoring relays are used for overtemperature supervision of motors equipped with Pt100 sensors. For example, there can be three sensors to measure the temperature of the motor windings and two sensors for the bearings. As the temperature rises, the sensor resistance increases linearly. At an adjustable wake-up level, the monitoring relay de-energizes its output.

The standard Pt100 relay options include two (+2L506), three (+3L506) or five (+5L506) relays.

By default, the relays are wired internally to digital input DI6 of the drive control unit. The loss of the input is set to trigger an external fault. The options include a terminal block for sensor connection. The output indication on the terminal block can be wired by the customer, for example, to an external monitoring circuit. See the circuit diagrams delivered with the drive.

See also

- firmware manual for parameter settings
- Pt100 relay alarm and trip limit setting instructions in the start-up instructions
- circuit diagrams delivered with the drive for the actual wiring.

### ■ Starter for auxiliary motor fan (options +M600...M605)

#### What the option contains

The option provides switched and protected connections for 3-phase auxiliary motor fans. Each fan connection is equipped with:

- fuses
- a manual motor starter switch with an adjustable current limit
- a contactor controlled by the drive, and
- terminal block X601 for customer connections.

#### Description

The output for the auxiliary fan is wired from the 3-phase supply voltage to terminal block X601 through a motor starter switch and a contactor. The contactor is operated by the drive. The 230 V AC control circuit is wired through a jumper on the terminal block; the jumper can be replaced by an external control circuit.

The starter switch has an adjustable trip current limit, and can be opened to permanently switch the fan off.

The statuses of both the starter switch and the fan contactor are wired to the terminal block.

---

See the circuit diagrams delivered with the drive for the actual wiring.

## Type designation label

The type designation label includes an IEC rating, appropriate markings, a type designation and a serial number, which allow identification of each unit. The type designation label is located on the front cover. An example label is shown below.

|    |   |
|----|---|
| 1  | Type designation, see section <a href="#">Type designation key</a> below.   |
| 2  | Manufacturing address   |
| 3  | Frame size  |
| 4  | Cooling method  |
| 5  | Degree of protection  |
| 6  | Ratings, see section <a href="#">Electrical ratings (page 191)</a> , <a href="#">Electrical power network specification (page 232)</a> and <a href="#">Motor connection data (page 232)</a> .   |
| 7  | Short-circuit withstand strength, see section <a href="#">Electrical power network specification (page 232)</a> .   |
| 8  | Valid markings  |
| 9  | Serial number. The first digit of the serial number refers to the manufacturing plant. The next four digits refer to the unit's manufacturing year and week, respectively. The remaining digits complete the serial number so that there are no two units with the same number. |
| 10 | Link to product information   |

## Type designation key

### ■ Type designation key

The type designation contains information on the specifications and configuration of the drive. The first digits from left express the basic drive type. The optional selections are given next, separated by plus signs. Codes that start with zero (eg. +0A123) indicate the absence of a specified feature. The main selections are described below. Not all selections are available for all types or in all regions. For more information, refer to the ordering instructions available on request.

## ■ Basic code

| Code                 | Description   |
|----------------------|---|
| ACH580               | Product series  |
| <b>Type</b>          |   |
| -07                  | The standard delivery includes: cabinet-installed drive, IP21, main switch, AC fuses, ACH-AP-H assistant control panel, EMC filtering for second environment TN grounded systems (category C3), input choke, common mode filter in frames R10 and R11, coated boards, ACH580 HVAC control program, EIA/RS-485 fieldbus connector, Safe torque off function, bottom entry and exit of cables, multilingual device label sticker, USB memory stick containing dimension drawing, circuit diagrams, part list and all manuals.<br>Refer to section <a href="#">Option codes (page 53)</a> for options. |
| <b>Size</b>          |   |
| -xxxxA               | See the ratings table.  |
| <b>Voltage range</b> |   |
| 4                    | 380...480 V. This is indicated in the type designation label as typical input voltage level (3~400/480 V AC).   |

## ■ Option codes

| Code | Description   |
|------|---|
| B054 | IP42 (UL Type 1 Filtered)   |
| B055 | IP54 (UL Type 12)   |
| C128 | Air inlet through bottom of cabinet. See section <a href="#">Air inlet through the bottom of the cabinet (option +C128) (page 68)</a> . |
| C129 | UL Listed (evaluated to both U.S. and Canadian safety requirements). See section <a href="#">UL Listed (option +C129) (page 47)</a> .   |
| C130 | Channeled air outlet. See section <a href="#">Channeled air outlet (option +C130) (page 47)</a> .                                       |
| C164 | Plinth height 100 mm. See section <a href="#">Plinth height (options +C164 and +C179) (page 48)</a> .                                   |
| C179 | Plinth height 200 mm. See section <a href="#">Plinth height (options +C164 and +C179) (page 48)</a> .                                   |
| C196 | Empty 400 mm wide cubicle on right. See section <a href="#">Empty cubicles on right (options +C196...C198) (page 48)</a> .              |
| C197 | Empty 600 mm wide cubicle on right. See section <a href="#">Empty cubicles on right (options +C196...C198) (page 48)</a> .              |
| C198 | Empty 800 mm wide cubicle on right. See section <a href="#">Empty cubicles on right (options +C196...C198) (page 48)</a> .              |
| C199 | Empty 400 mm wide cubicle on left. See section <a href="#">Empty cubicles on left (options +C199...C201) (page 48)</a> .                |
| C200 | Empty 600 mm wide cubicle on left. See section <a href="#">Empty cubicles on left (options +C199...C201) (page 48)</a> .                |
| C201 | Empty 800 mm wide cubicle on left. See section <a href="#">Empty cubicles on left (options +C199...C201) (page 48)</a> .                |
| E202 | EMC/RFI filter for 1st environment TN (grounded) system, category C2  |
| E205 | du/dt filtering   |
| E208 | Common mode filtering   |
| F250 | Main (line) contactor   |
| F289 | MCCB circuit breaker  |

## 54 Operation principle and hardware description

| Code | Description  |
|------|--|
| G300 | Cabinet and module heating elements (external supply). See section <a href="#">Cabinet heater with external supply (option +G300) (page 49)</a> .  |
| G307 | Terminals for connecting external control voltage (230 V AC or 115 V AC, eg. UPS). See section <a href="#">Terminals for external control voltage (option +G307) (page 49)</a> .   |
| G313 | Output for motor space heater (external supply)  |
| G327 | Ready light on door, white   |
| G328 | Run light on door, green   |
| G329 | Fault light on door, yellow  |
| H351 | Power cabling entry from top. See section <a href="#">Top cable entry/exit (options +H351 and +H353) (page 49)</a> .   |
| H353 | Power cabling exit from top. See section <a href="#">Top cable entry/exit (options +H351 and +H353) (page 49)</a> .  |
| H358 | Cable gland plates (3 mm steel, undrilled)   |
| J429 | ACH-AP-W control panel (with Bluetooth)  |
| K451 | FDNA-01 DeviceNet™ adapter module  |
| K454 | FPBA-01 PROFIBUS DP® adapter module  |
| K457 | FCAN-01 CANopen® adapter module  |
| K458 | FSCA-01 RS-485 (Modbus/RTU) adapter module   |
| K465 | FBIP-21 BACnet/IP adapter module   |
| K469 | FECA-01 EtherCAT® adapter module   |
| K470 | FEPL-02 Ethernet POWERLINK adapter module  |
| K475 | FENA-21 Ethernet adapter module for EtherNet/IP™, Modbus TCP and PROFINET IO protocols, 2-port   |
| K496 | Connectivity for wired remote monitoring. Includes NETA-21 remote monitoring tool with Ethernet connection, FMBT-21 Modbus/TCP adapter module (+K491). See section <a href="#">Connectivity for wired remote monitoring (option +K496) (page 50)</a> . |
| K497 | Connectivity for wireless remote monitoring. Includes NETA-21 remote monitoring tool, FMBT-21 Modbus/TCP adapter module (+K491) and 4G modem. See section <a href="#">Connectivity for wireless remote monitoring (option +K497) (page 50)</a> .       |
| L501 | CMOD-01 External 24 V AC/DC and digital I/O extension (2×RO and 1×DO)  |
| L504 | Additional I/O terminal block. See section <a href="#">Additional terminal block X504 (option +L504) (page 50)</a> .   |
| L506 | Thermal protection with Pt100 relays (2, 3, 5 or 8 pcs). See section <a href="#">Thermal protection with Pt100 relays (option +nL506) (page 51)</a> .  |
| L512 | CHDI-01 115/230 V digital input module (six digital inputs and two relay outputs).   |
| L523 | CMOD-02 External 24 V and isolated PTC interface   |
| L525 | FAIO-01 analog I/O extension module  |
| M600 | Starter for auxiliary motor fan, trip limit 1 ... 1.6 A  |
| M601 | Starter for auxiliary motor fan, trip limit 1.6 ... 2.5 A  |
| M602 | Starter for auxiliary motor fan, trip limit 2.5 ... 4 A  |
| M603 | Starter for auxiliary motor fan, trip limit 4 ... 6.3 A  |
| M604 | Starter for auxiliary motor fan, trip limit 6.3 ... 10 A   |
| M605 | Starter for auxiliary motor fan, trip limit 10...16 A  |
| P912 | Seaworthy packaging  |
| P931 | Extended warranty (36 months from delivery)  |
| P932 | Extended warranty (60 months from delivery)  |

| <b>Code</b> | <b>Description</b>   |
|-------------|--|
| Q951        | Emergency stop (category 0) with safety relays, by opening the main breaker/contactors     |
| Q963        | Emergency stop (category 0) with safety relays, by activating the Safe torque off function |
| Q971        | ATEX-certified safe disconnection function   |
| R700        | Printed documents in English   |
| R701        | Printed documents in German <sup>1)</sup>  |
| R702        | Printed documents in Italian <sup>1)</sup>   |
| R703        | Printed documents in Dutch <sup>1)</sup>   |
| R704        | Printed documents in Danish <sup>1)</sup>  |
| R705        | Printed documents in Swedish <sup>1)</sup>   |
| R706        | Printed documents in Finnish <sup>1)</sup>   |
| R707        | Printed documents in French <sup>1)</sup>  |
| R708        | Printed documents in Spanish <sup>1)</sup>   |
| R709        | Printed documents in Portuguese <sup>1)</sup>  |
| R711        | Printed documents in Russian <sup>1)</sup>   |

<sup>1)</sup> The delivery can include documents in English if the requested language is not available.

---





# 4

## Mechanical installation

---

### Contents of this chapter

This chapter describes the mechanical installation procedure of the drive.



### Examining the installation site

Examine the installation site. Make sure that:

- The installation site is sufficiently ventilated or cooled to remove heat from the drive. Refer to the technical data.
  - The ambient conditions of the drive meet the specifications. Refer to the technical data.
  - The material behind, above, and below the drive is non-flammable.
  - There is sufficient free space above the drive for cooling, maintenance work, and operation of the pressure relief (if present).
  - The floor that the drive cabinet is installed on is of non-flammable material, as smooth as possible, and strong enough to hold the weight of the unit. Examine the flatness of the floor with a spirit level. The maximum permitted deviation from a level surface is 5 mm (0.2 in) for every 3 meters (10 ft). If it is necessary, level the installation site, as the cabinet does not have adjustable feet.
-

Do not install the drive on an elevated platform or in a recess. The module extraction/installation ramp included with the drive is only suitable for a maximum height difference of 50 mm (2 in), that is, the standard plinth height of the drive.

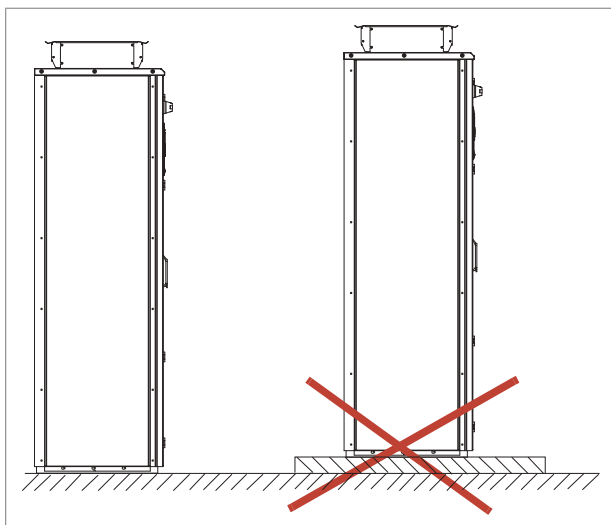

## Necessary tools

The tools required for moving the unit to its final position, fastening it to the floor and wall and tightening the connections are listed below:

- crane, fork-lift or pallet truck (check load capacity!), slate/spud bar, jack and rollers
- Pozidriv and Torx screwdrivers
- torque wrench
- set of wrenches or sockets.

## Moving and unpacking the drive

Move the drive preferably in the original package to installation site as shown below to avoid damaging the cabinet surfaces and door devices. When you use a pallet truck, check its load capacity before you move the drive.

Horizontal package (frames R6...R9):

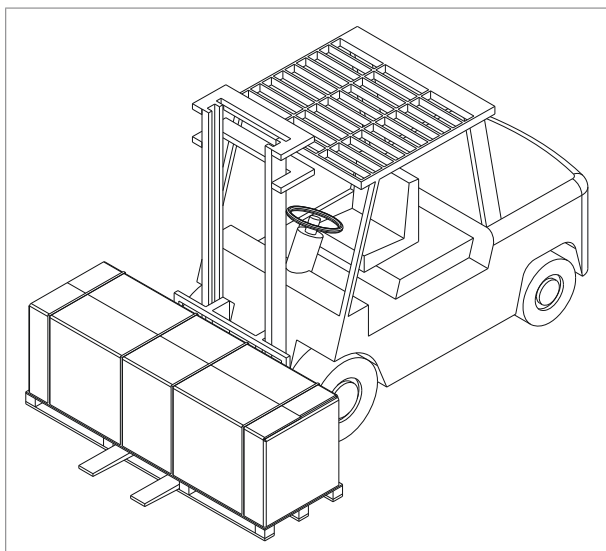

Vertical package (frames R10 and R11):

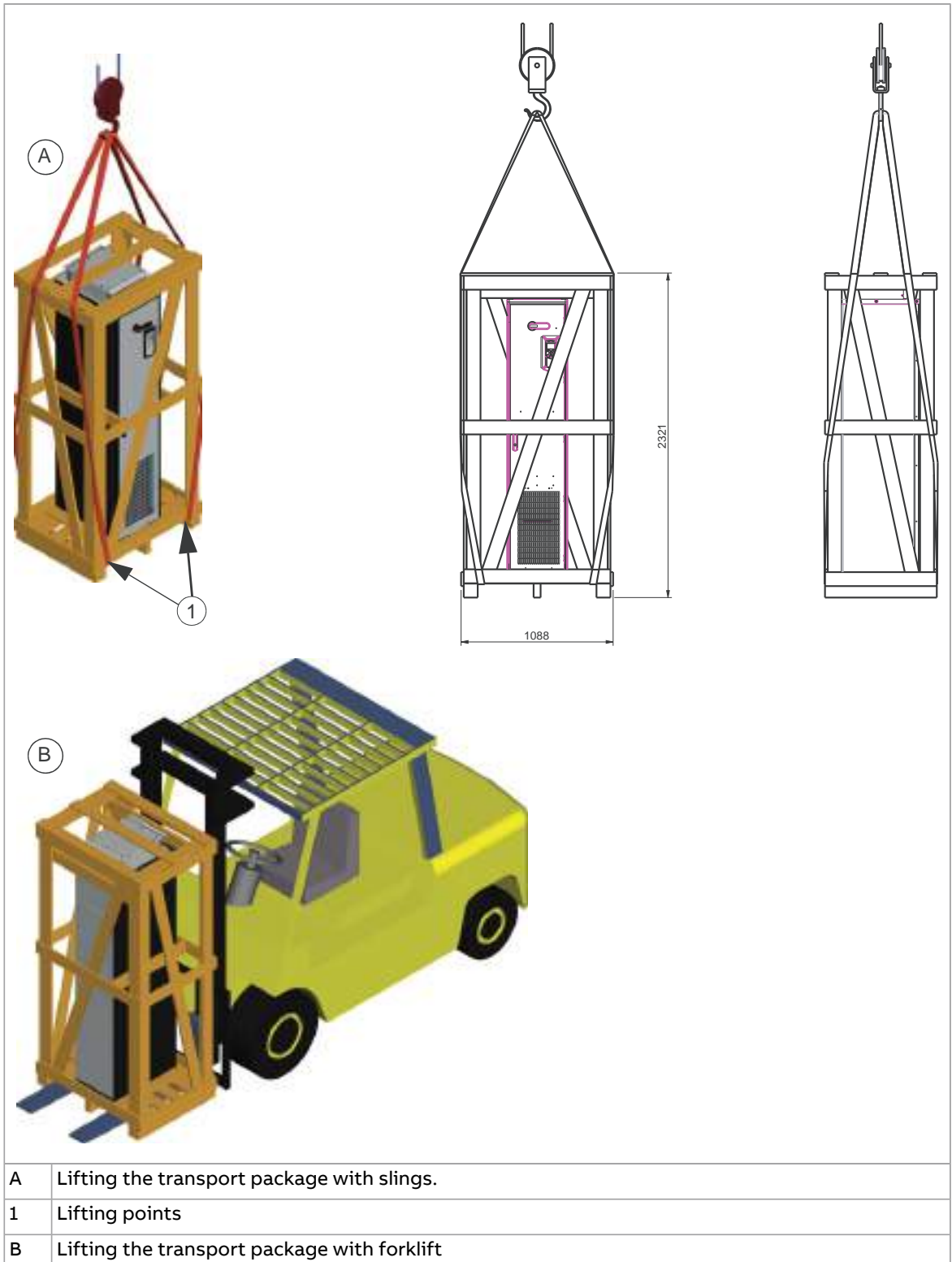

■ **Unpacking the transport package**

This drawing shows the layout of the horizontal transport package.

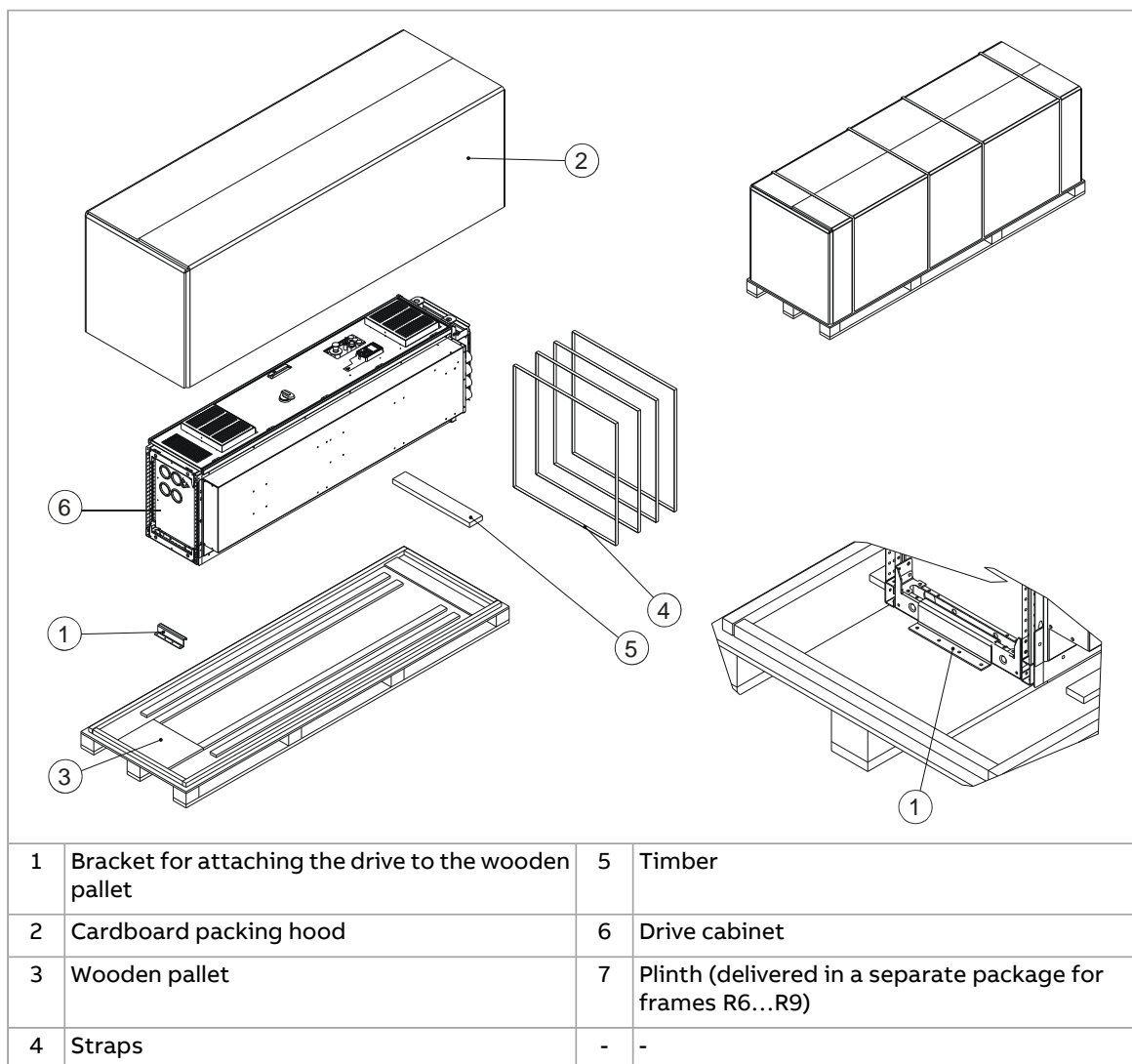

Unpack the horizontal transport package as follows:

1. Cut the straps (4).
2. Remove the hood (2).
3. Undo the screws that attach the bracket (1) to the wooden pallet.
4. Remove the plastic wrapping.

Unpack the vertical transport package as follows:

1. Undo the screws that attach the wooden parts of the transport crate to each other.
2. Remove the wooden parts.
3. Remove the clamps with which the drive cabinet is mounted onto the transport pallet by undoing the fastening screws.
4. Remove the plastic wrapping.

## ■ Examining the delivery

The drive delivery contains:

- drive cabinet line-up
- optional modules (if ordered) installed onto the control unit(s) at the factory
- appropriate drive and optional module manuals
- delivery documents.

Make sure that there are no signs of damage. Before attempting installation and operation, see the information on the type designation labels of the drive to verify that the delivery is of the correct type.

## ■ Lifting the cabinet



### **WARNING!**

Obey the local laws and regulations that apply to lifting, such as the requirements for planning the lift, the capacity and condition of the lifting equipment, and personnel training.

Lift the drive cabinet up using its lifting lugs.

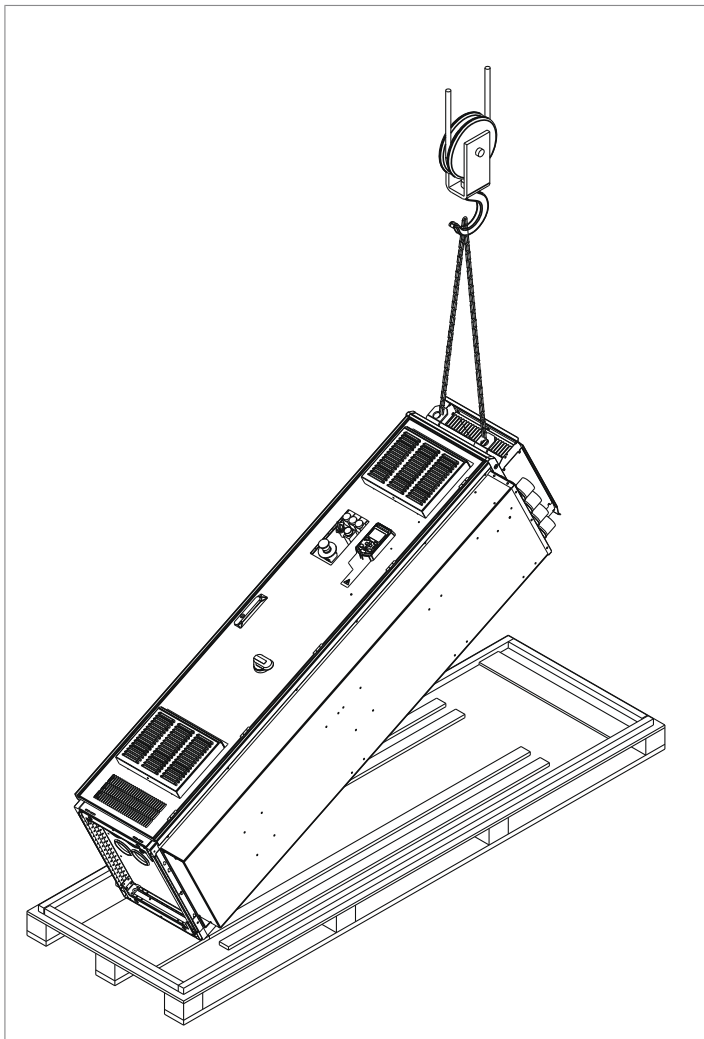

## 62 Mechanical installation

Lift the cabinet to its position. Maximum allowed angle of the lifting slings is 20° (10° for frames R10 and R11, IP54).

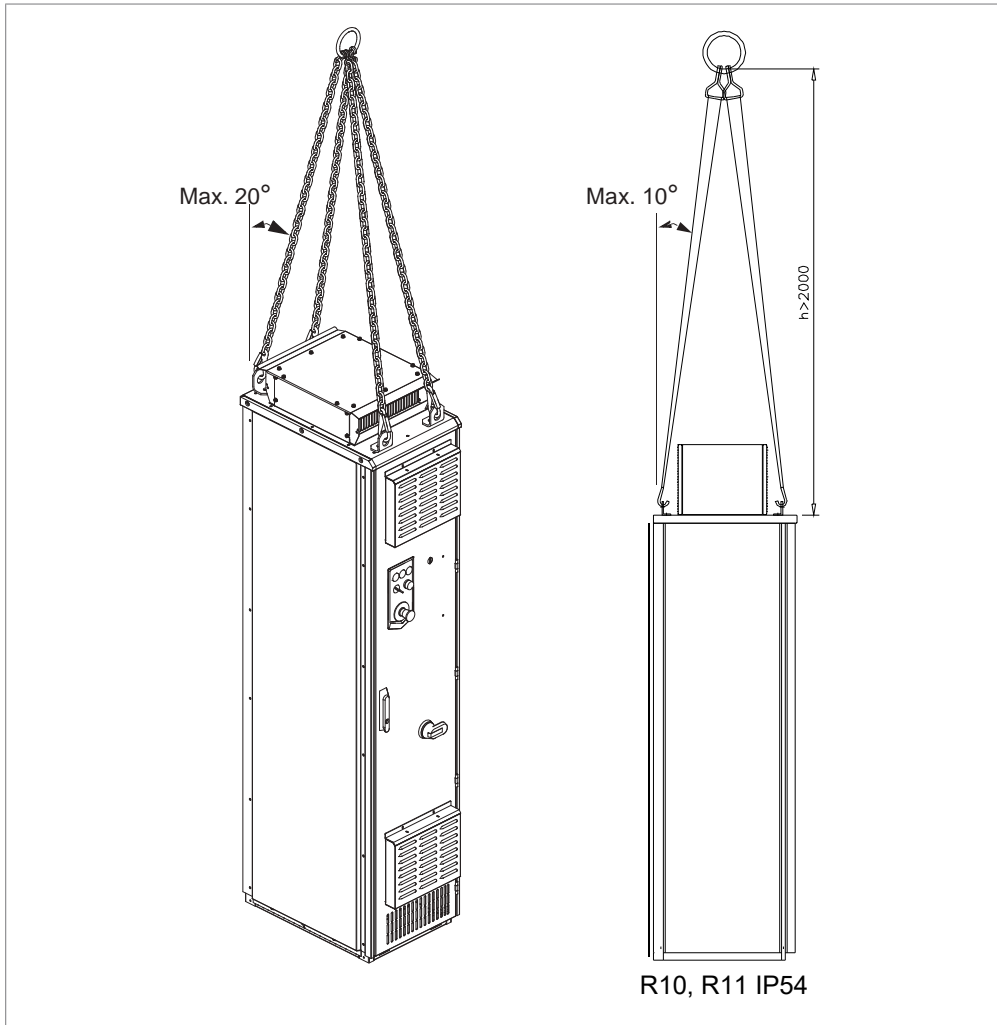

### Lifting lugs

#### Certificate of conformity

The certificate is available in ABB Library at [www.abb.com/drives/documents](http://www.abb.com/drives/documents) (document number 3AXD10001061361).

#### Declarations of conformity



[Link to Declaration of conformity according to EU Machinery Directive 2006/42/EU \(3AXD10000686042\)](#)



[Link to Declaration of conformity according to UK Supply of Machinery \(Safety\) Regulations 2008 \(3AXD10001329600\)](#)

## ■ Moving the cabinet after unpacking

Move drive cabinet carefully in the upright position. Avoid tilting. The center of gravity of the cabinet is high.

### Moving the cabinet on rollers

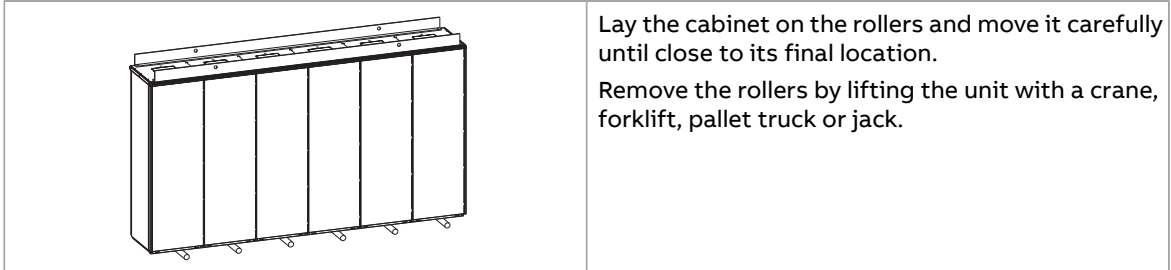

### Moving the cabinet to its final position

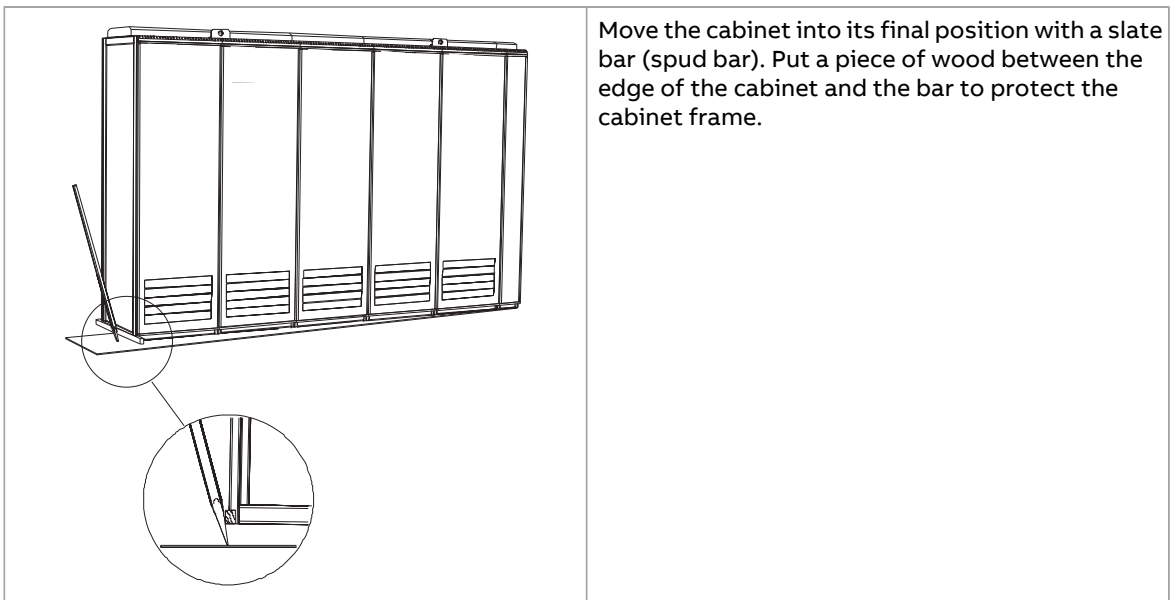

## Attaching the cabinet to the floor and wall or roof

### ■ General rules

- The drive must be installed in an upright vertical position.
- Leave 400 mm (15.75") of free space above the basic roof level of the cabinet for cooling.
- The cabinet can be installed with its back against a wall (a), or back-to-back with another unit (b).
- Leave some space ( $w$ ) at the side where the cabinet outmost hinges are to allow the doors to open sufficiently. The doors must open 120° to allow module replacement.

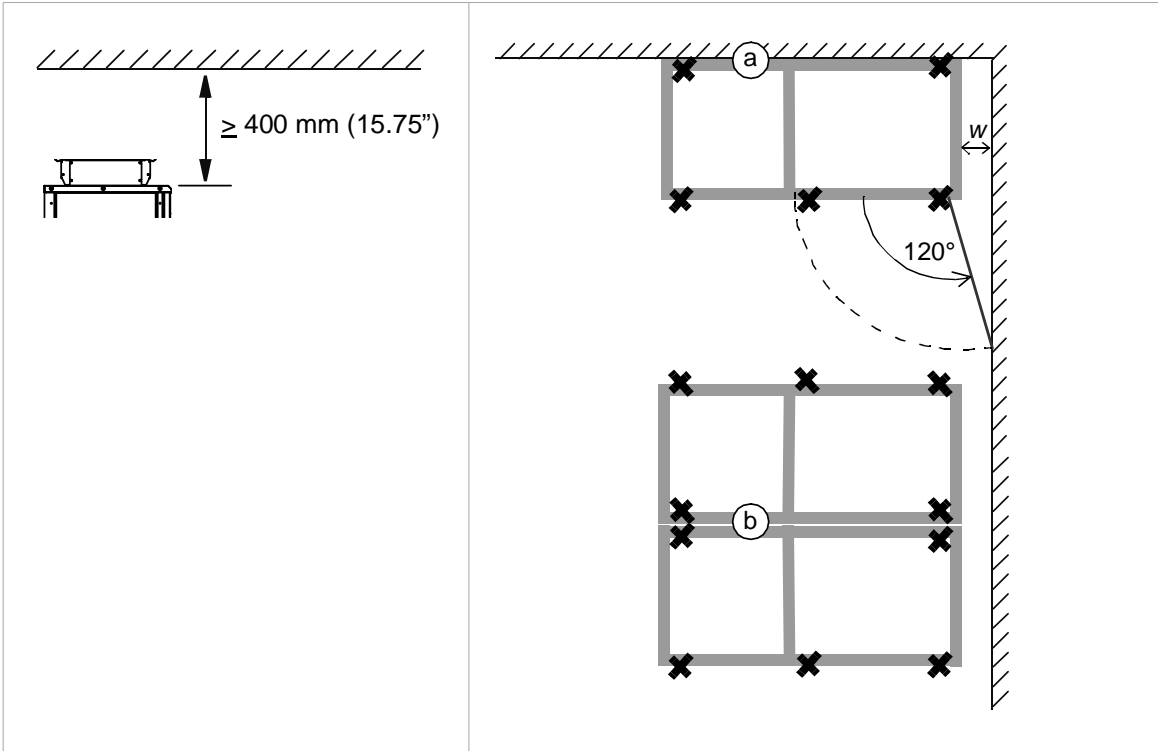

**Note 1:** Any height adjustment must be done before attaching the cabinet sections to the floor or to each other. Height adjustment can be done by using metal shims between the cabinet bottom and floor.

**Note 2:** Depending on the size of the cabinet, it has either bolt-on lifting eyes, or lifting bars with lifting holes. Bolt-on lifting eyes need not be removed unless the holes are used for attaching the cabinet. If the cabinet is delivered with lifting bars, remove them and store them for decommissioning. Plug any unused holes using the existing bolts and sealing rings included. Tighten to 70 N·m (52 lbf·ft).

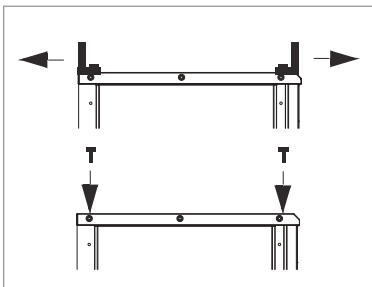

**WARNING!**



Do not stand or walk on the cabinet roof. Make sure that nothing presses against the roof, side or back plates or door. Do not store anything on the roof while the drive is in operation.



■ **Attaching the cabinet (non-marine units)**

**Alternative 1 – Clamping**

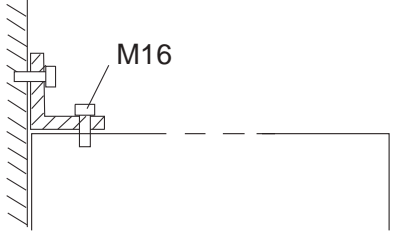
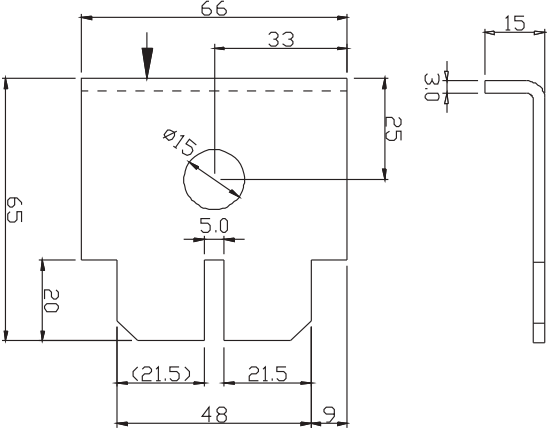
1. Insert the clamps (included) into the twin slots along the front and rear edges of the cabinet frame body and fasten them to the floor with a bolt. The recommended maximum distance between the clamps in the front edge is 800 mm (31.5”).
2. If floor mounting at the back is not possible, attach the top of the cabinet to the wall with L-brackets (not included in the delivery) bolted to the lifting eye/bar holes, and suitable hardware.

| Clamping bottom to floor  | Attaching top to wall   |
|---|---|
|   |   |
|  |  |



### Alternative 2 – Using the holes inside the cabinet

1. Attach the cabinet to the floor through the bottom fastening holes with size M10...M12 (3/8"...1/2") bolts. The recommended maximum distance between the front edge fastening points is 800 mm (31.5").
2. If the back fastening holes are not accessible, attach the top of the cabinet to the wall with L-brackets (not included in the delivery) bolted to the lifting eye/bar holes.

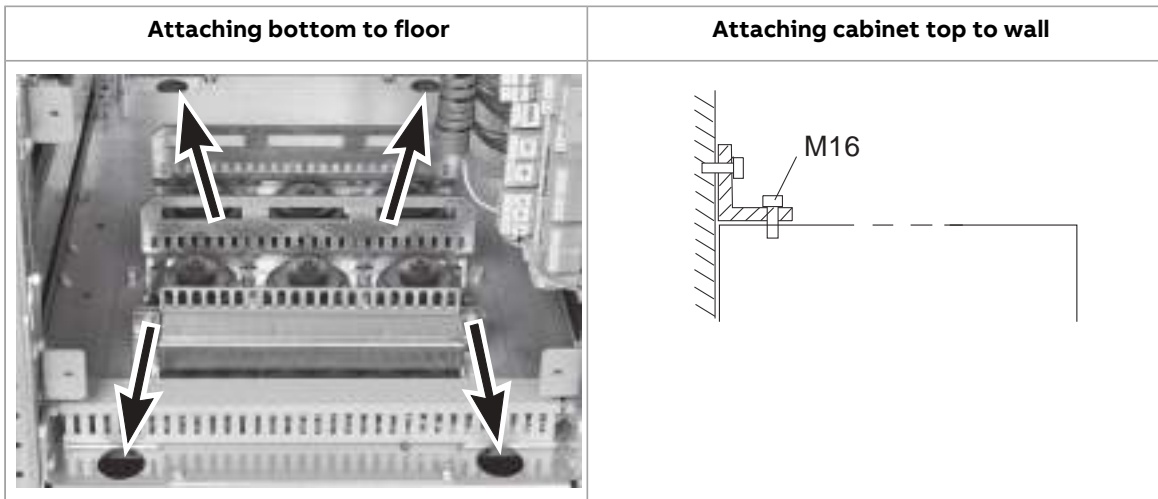

**Alternative 3 – Cabinets with plinth options +C164 and +C179**

1. Attach the plinth to the floor with the brackets included in the plinth package.

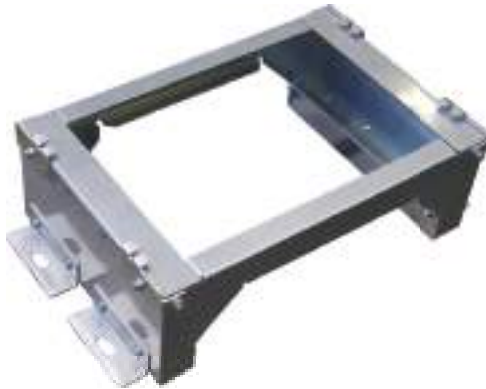

2. Lift the cabinet onto the plinth and attach it to the plinth with the L-brackets delivered with the plinth.

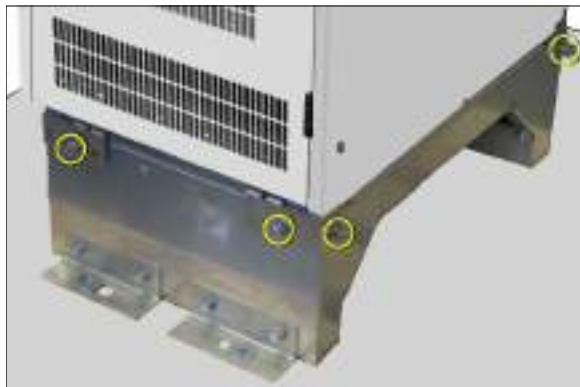

3. Attach the brackets of the front cover plate to the plinth with screws (Hex M8×20 full thread or equal) and M8 washers and nuts.
4. Attach the front cover plate to the brackets.
5. Attach each side cover plate with 3 screws (combi screw M5×12, Torx T20 or equal).



## Miscellaneous

### ■ Cable duct in the floor below the cabinet

A cable duct can be constructed below the 500 mm wide middle part of the cabinet. The cabinet weight lies on the two 50 mm wide transverse sections which the floor must carry.

Prevent the cooling air flow from the cable duct to the cabinet by bottom plates. To ensure the degree of protection for the cabinet, use the original bottom plates delivered with the unit. With user-defined cable entries, take care of the degree of protection, fire protection and EMC compliance.

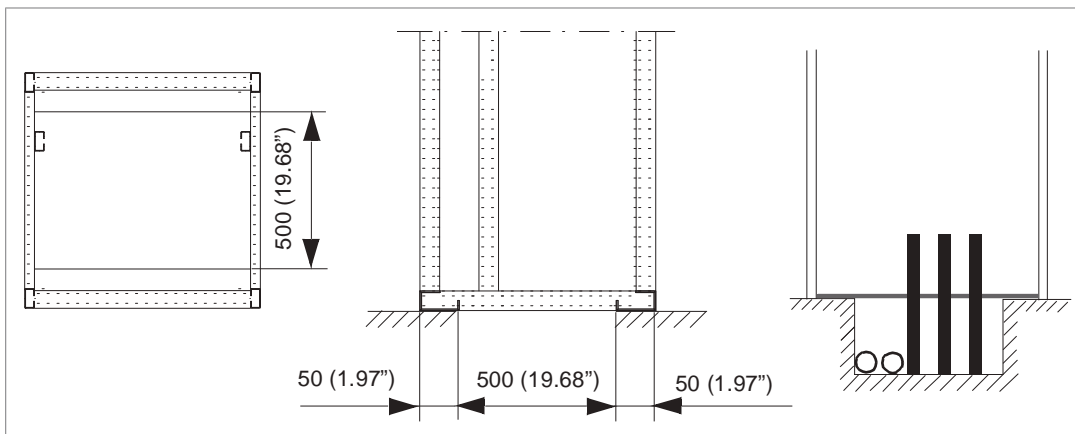

### ■ Arc welding

ABB does not recommend attaching the cabinet by arc welding. However, if arc welding is the only option, connect the return conductor of the welding equipment to the cabinet frame at the bottom within 0.5 meters (1'6") of the welding point.

**Note:** The cabinet frame is zinc-plated.



#### **WARNING!**

Make sure that the return wire is connected correctly. Welding current must not return via any component or cabling of the drive. If the welding return wire is connected incorrectly, the welding circuit can damage electronic circuits in the cabinet.



#### **WARNING!**

Do not inhale the welding fumes.

### ■ Air inlet through the bottom of the cabinet (option +C128)

Drives with air inlet through the bottom of the cabinet (option +C128) are intended for installation on an air duct in the floor.

An example of the air inlets in the cabinet bottom plate is shown below. Refer also to the dimension drawings delivered with the drive.

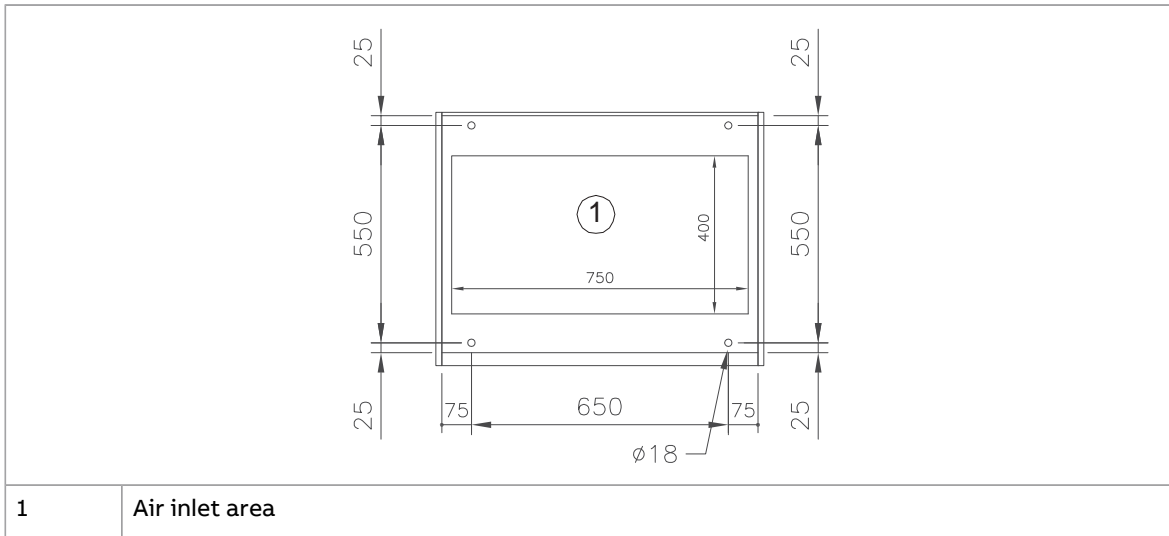

Support the plinth of the cabinet all round.

The air duct must be able to supply a sufficient volume of cooling air. See technical data for the minimum air flow values.



**WARNING!**

Make sure that the incoming air is sufficiently clean. If not, dust goes into the cabinet. The outlet filter on the cabinet roof prevents dust from going out. The collected dust can cause drive malfunction and danger of fire.

■ **Air outlet duct on the cabinet roof (option +C130)**

The option adds air outlet ducts to each cubicle of the cabinet line-up. The outlet diameter (and quantity) of the ducts depend on the cubicle width. The ducts used are from the Veloduct series by FläktGroup.

| Cubicle width (mm) | Outlet duct    |                     |                     |  | Channel                         |
|--------------------|----------------|---------------------|---------------------|--|---------------------------------|
|                    | Veloduct type  | Outer diameter (mm) | Inner diameter (mm) | Cross-sectional area (m <sup>2</sup> ) | Recommended inner diameter (mm) |
| 300                | BDEA-6-020     | 200                 | 194                 | 0.030                                  | 200.0 ... 200.7                 |
| 400                | BDEA-6-031     | 310                 | 304                 | 0.073                                  | 315.0 ... 315.9                 |
| 500                | BDEA-6-031     | 310                 | 304                 | 0.073                                  | 315.0 ... 315.9                 |
| 600                | BDEA-6-040     | 400                 | 394                 | 0.122                                  | 400.0 ... 401.0                 |
| 700                | BDEA-6-040     | 400                 | 394                 | 0.122                                  | 400.0 ... 401.0                 |
| 800                | 2 × BDEA-6-031 | 310                 | 304                 | 0.145                                  | 315.0 ... 315.9                 |
| 1000               | 2 × BDEA-6-031 | 310                 | 304                 | 0.145                                  | 315.0 ... 315.9                 |

The ventilation system must keep the static pressure in the air outlet duct sufficiently below the pressure of the room where the drive is located in order that the cabinet fans can produce the required air flow through the cabinet. Make sure that no dirty or moist air is able to flow backward to the drive in any case, even during off-time or while servicing the drive or the ventilation system.

### Calculating the required static pressure difference

The required static pressure difference between the exit air duct and the drive installation room can be calculated as follows:

$$\Delta p_s = (1.5 \dots 2) \cdot p_d$$

where

$$p_d = 0.5 \cdot \rho \cdot v_m^2$$

$$v_m = q / A_c$$

|        |  |
|--------|--|
| $p_d$  | Dynamic pressure   |
| $\rho$ | Air density (kg/m <sup>3</sup> )                           |
| $v_m$  | Average air velocity in the exit duct(s) (m/s)             |
| $q$    | Rated air flow of the drive (m <sup>3</sup> /s)            |
| $A_c$  | Cross-sectional area of the exit duct(s) (m <sup>2</sup> ) |

### Example

The cabinet has 3 exit openings of 315 mm diameter. The rated air flow of the cabinet is 4650 m<sup>3</sup>/h = 1.3 m<sup>3</sup>/s.

$$A_c = 3 \cdot 0.315^2 \cdot \pi / 4 = 0.234 \text{ m}^2$$

$$v_m = 1.3 / 0.234 = 5.5 \text{ m/s}$$

$$p_d = 0.5 \cdot \rho \cdot v_m^2 = 0.5 \cdot 1.1 \cdot 5.5^2 = 17 \text{ Pa}$$

The required pressure in the exit air duct is then  $1.5 \dots 2 \cdot 17 \text{ Pa} = 26 \dots 34 \text{ Pa}$  below the pressure in the room.



# 5

## Guidelines for planning the electrical installation

---

### Contents of this chapter

This chapter contains guidelines for planning the electrical installation of the drive.

### Limitation of liability

The installation must always be designed and made according to applicable local laws and regulations. ABB does not assume any liability whatsoever for any installation which breaches the local laws and/or other regulations. Furthermore, if the recommendations given by ABB are not followed, the drive may experience problems that the warranty does not cover.

#### ■ North America

Installations must be compliant with NFPA 70 (NEC)<sup>1)</sup> and/or Canadian Electrical Code (CE) along with state and local codes for your location and application.

<sup>1)</sup> National Fire Protection Association 70 (National Electric Code).

### Selecting the supply disconnecting device

The drive is equipped with a main disconnecting device as standard. Depending on the size of the drive, and the selected options, the type of disconnecting device may vary. Examples: switch-disconnector, withdrawable air circuit breaker, etc.

### Selecting the main contactor or breaker

You can order the drive with a main contactor (option +F250) or a molded case circuit breaker (option +F289).

---



## Examining the compatibility of the motor and drive

Use asynchronous AC induction motors, permanent magnet synchronous motors or ABB synchronous reluctance motors (SynRM motors) with the drive.

Select the motor size and drive type from the rating table on basis of the AC line voltage and motor load. You can find the rating table in the appropriate hardware manual. You can also use the DriveSize PC tool.

Make sure that the motor can be used with an AC drive. See [Requirements tables \(page 72\)](#). For basics of protecting the motor insulation and bearings in drive systems, see [Protecting the motor insulation and bearings \(page 72\)](#).

### Note:

- Consult the motor manufacturer before using a motor with nominal voltage that differs from the AC line voltage connected to the drive input.
- The voltage peaks at the motor terminals are relative to the supply voltage of the drive, not to the drive output voltage.

### ■ Protecting the motor insulation and bearings

The drive employs modern IGBT inverter technology. Regardless of frequency, the drive output comprises pulses of approximately the drive DC bus voltage with a very short rise time. The pulse voltage can almost double at the motor terminals, depending on the attenuation and reflection properties of the motor cable and the terminals. This can cause additional stress on the motor and motor cable insulation.

Modern variable speed drives with their fast rising voltage pulses and high switching frequencies can generate current pulses that flow through the motor bearings. This can gradually erode the bearing races and rolling elements.

$du/dt$  filters protect motor insulation system and reduce bearing currents. Common mode filters mainly reduce bearing currents. Insulated N-end (non-drive end) bearings protect the motor bearings.

### ■ Requirements tables

These tables show how to select the motor insulation system and when a drive  $du/dt$  and common mode filters and insulated N-end (non-drive end) motor bearings are required. Ignoring the requirements or improper installation may shorten motor life or damage the motor bearings and voids the warranty.





**Requirements for ABB motors,  $P_n < 100$  kW (134 hp)**See also [Abbreviations \(page 76\)](#).

| Motor type   | Nominal AC line voltage                                   | Motor insulation system                | Requirement for   |
|--|---|--|---|
|  |   |  | ABB $du/dt$ and common mode filters, insulated N-end motor bearings |
|  |   |  | $P_n < 100$ kW and frame size < IEC 315                             |
|  |   |  | $P_n < 134$ hp and frame size < NEMA 500                            |
| Random-wound M2_, M3_ and M4_                        | $U_n \leq 500$ V  | Standard                               | -   |
|  | $500$ V < $U_n \leq 600$ V                                | Standard                               | + $du/dt$   |
|  |   | Reinforced                             | -   |
|  | $600$ V < $U_n \leq 690$ V<br>(cable length $\leq 150$ m) | Reinforced                             | + $du/dt$   |
| $600$ V < $U_n \leq 690$ V<br>(cable length > 150 m) | Reinforced  | -                                      |   |
| Form-wound HX_ and AM_                               | $380$ V < $U_n \leq 690$ V                                | Standard                               | N/A   |
| Old <sup>1)</sup> form-wound HX_ and modular         | $380$ V < $U_n \leq 690$ V                                | Check with the motor manufacturer.     | + N + $du/dt$ with voltages over 500 V + CMF                        |
| Random-wound HX_ and AM_ <sup>2)</sup>               | $0$ V < $U_n \leq 500$ V                                  | Enamelled wire with fiber glass taping | + N + CMF   |
|  | $500$ V < $U_n \leq 690$ V                                |  | + N + $du/dt$ + CMF   |
| HDP  | Consult the motor manufacturer.                           |  |   |

1) manufactured before 1.1.1998

2) For motors manufactured before 1.1.1998, check for additional instructions with the motor manufacturer.



**Requirements for ABB motors,  $P_n \geq 100$  kW (134 hp)**See also [Abbreviations \(page 76\)](#).

| Motor type  | Nominal AC line voltage  | Requirement for                        |   |   |
|---|--|--|---|---|
|   |  | Motor insulation system                | ABB $du/dt$ and common mode filters, insulated N-end motor bearings   |   |
|   |  |  | $100 \text{ kW} \leq P_n < 350 \text{ kW}$<br>or<br>$\text{IEC } 315 \leq \text{frame size} < \text{IEC } 400$      | $P_n \geq 350 \text{ kW}$<br>or<br>$\text{frame size} \geq \text{IEC } 400$ |
|   |  |  | $134 \text{ hp} \leq P_n < 469 \text{ hp}$<br>or<br>$\text{NEMA } 500 \leq \text{frame size} \leq \text{NEMA } 580$ | $P_n \geq 469 \text{ hp}$<br>or<br>$\text{frame size} > \text{NEMA } 580$   |
| Random-wound M2_, M3_ and M4_   | $U_n \leq 500 \text{ V}$   | Standard                               | + N   | + N + CMF   |
|   | $500 \text{ V} < U_n \leq 600 \text{ V}$   | Standard                               | + N + $du/dt$   | + N + $du/dt$ + CMF   |
|   |  | Reinforced                             | + N   | + N + CMF   |
|   | $600 \text{ V} < U_n \leq 690 \text{ V}$<br>(cable length $\leq 150 \text{ m}$ ) | Reinforced                             | + N + $du/dt$   | + N + $du/dt$ + CMF   |
| $600 \text{ V} < U_n \leq 690 \text{ V}$<br>(cable length $> 150 \text{ m}$ ) | Reinforced   | + N                                    | + N + CMF   |   |
| Form-wound HX_ and AM_  | $380 \text{ V} < U_n \leq 690 \text{ V}$   | Standard                               | + N + CMF   | $P_n < 500 \text{ kW}$ : + N + CMF  |
|   |  |  |   | $P_n \geq 500 \text{ kW}$ : + N + $du/dt$ + CMF                             |
| Old <sup>1)</sup> form-wound HX_ and modular                                  | $380 \text{ V} < U_n \leq 690 \text{ V}$   | Check with the motor manufacturer.     | + N + $du/dt$ with voltages over 500 V + CMF  |   |
| Random-wound HX_ and AM_ <sup>2)</sup>  | $0 \text{ V} < U_n \leq 500 \text{ V}$   | Enamelled wire with fiber glass taping | + N + CMF   |   |
|   | $500 \text{ V} < U_n \leq 690 \text{ V}$   |  | + N + $du/dt$ + CMF   |   |
| HDP   | Consult the motor manufacturer.  |  |   |   |

1) manufactured before 1.1.1998

2) For motors manufactured before 1.1.1998, check for additional instructions with the motor manufacturer.

**Requirements for non-ABB motors,  $P_n < 100$  kW (134 hp)**See also [Abbreviations \(page 76\)](#).

| Motor type                  | Nominal AC line voltage    | Motor insulation system  | Requirement for   |
|-----------------------------|----------------------------|--|---|
|                             |                            |  | ABB $du/dt$ and common mode filters, insulated N-end motor bearings |
|                             |                            |  | $P_n < 100$ kW and frame size < IEC 315                             |
|                             |                            |  | $P_n < 134$ hp and frame size < NEMA 500                            |
| Random-wound and form-wound | $U_n \leq 420$ V           | Standard:<br>$\hat{U}_{LL} = 1300$ V   | -   |
|                             | $420$ V < $U_n \leq 500$ V | Standard:<br>$\hat{U}_{LL} = 1300$ V   | + $du/dt$   |
|                             |                            | Reinforced:<br>$\hat{U}_{LL} = 1600$ V,<br>0.2 $\mu$ s rise time               | -   |
|                             | $500$ V < $U_n \leq 600$ V | Reinforced:<br>$\hat{U}_{LL} = 1600$ V   | + $du/dt$   |
|                             |                            | Reinforced:<br>$\hat{U}_{LL} = 1800$ V   | -   |
|                             | $600$ V < $U_n \leq 690$ V | Reinforced:<br>$\hat{U}_{LL} = 1800$ V   | + $du/dt$   |
|                             |                            | Reinforced:<br>$\hat{U}_{LL} = 2000$ V,<br>0.3 $\mu$ s rise time <sup>1)</sup> | -   |

<sup>1)</sup> If the intermediate DC circuit voltage of the drive is increased from the nominal level due to long term resistor braking cycles, check with the motor manufacturer if additional output filters are needed.



**Requirements for non-ABB motors,  $P_n \geq 100$  kW (134 hp)**See also [Abbreviations \(page 76\)](#).

| Motor type  | Nominal AC line voltage                  | Motor insulation system   | Requirement for   |   |
|---|--|---|---|---|
|   |  |   | ABB $du/dt$ and common mode filters, insulated N-end motor bearings   |   |
|   |  |   | $100 \text{ kW} \leq P_n < 350 \text{ kW}$<br>or<br>$\text{IEC } 315 \leq \text{frame size} < \text{IEC } 400$      | $P_n \geq 350 \text{ kW}$<br>or<br>$\text{frame size} \geq \text{IEC } 400$ |
|   |  |   | $134 \text{ hp} \leq P_n < 469 \text{ hp}$<br>or<br>$\text{NEMA } 500 \leq \text{frame size} \leq \text{NEMA } 580$ | $P_n \geq 469 \text{ hp}$<br>or<br>$\text{frame size} > \text{NEMA } 580$   |
| Random-wound and form-wound   | $U_n \leq 420 \text{ V}$                 | Standard:<br>$\hat{U}_{LL} = 1300 \text{ V}$                                    | + N or CMF  | + N + CMF   |
|   | $420 \text{ V} < U_n \leq 500 \text{ V}$ | Standard:<br>$\hat{U}_{LL} = 1300 \text{ V}$                                    | + $du/dt$ + (N or CMF)  | + N + $du/dt$ + CMF   |
|   |  | Reinforced:<br>$\hat{U}_{LL} = 1600 \text{ V}$ ,<br>0.2 $\mu\text{s}$ rise time | + N or CMF  | + N + CMF   |
|   | $500 \text{ V} < U_n \leq 600 \text{ V}$ | Reinforced:<br>$\hat{U}_{LL} = 1600 \text{ V}$                                  | + $du/dt$ + (N or CMF)  | + N + $du/dt$ + CMF   |
|   |  | Reinforced:<br>$\hat{U}_{LL} = 1800 \text{ V}$                                  | + N or CMF  | + N + CMF   |
|   | $600 \text{ V} < U_n \leq 690 \text{ V}$ | Reinforced:<br>$\hat{U}_{LL} = 1800 \text{ V}$                                  | + $du/dt$ + N   | + N + $du/dt$ + CMF   |
| Reinforced:<br>$\hat{U}_{LL} = 2000 \text{ V}$ ,<br>0.3 $\mu\text{s}$ rise time <sup>1)</sup> |  | + N + CMF   | + N + CMF   |   |

<sup>1)</sup> If the intermediate DC circuit voltage of the drive is increased from the nominal level due to long term resistor braking cycles, check with the motor manufacturer if additional output filters are needed.

**Abbreviations**

| Abbr.          | Definition  |
|----------------|---|
| $U_n$          | Nominal AC line voltage   |
| $\hat{U}_{LL}$ | Peak line-to-line voltage at motor terminals which the motor insulation must withstand          |
| $P_n$          | Motor nominal power   |
| $du/dt$        | $du/dt$ filter at the output of the drive   |
| CMF            | Common mode filter of the drive   |
| N              | N-end bearing: insulated motor non-drive end bearing  |
| n.a.           | Motors of this power range are not available as standard units. Consult the motor manufacturer. |

### Availability of du/dt filter and common mode filter by drive type

| Product type | Availability of du/dt filter | Availability of common mode filter (CMF) |
|--------------|------------------------------|--|
| ACH580-07    | +E205                        | +E208                                    |

### Additional requirements for explosion-safe (EX) motors

If you use an explosion-safe (EX) motor, obey the rules in the requirements table above. In addition, consult the motor manufacturer for any further requirements.

### Additional requirements for ABB motors of types other than M2\_, M3\_, M4\_, HX\_ and AM\_

Use the selection criteria given for non-ABB motors.

### Additional requirements for ABB high-output and IP23 motors

The rated output power of high output motors is higher than what is stated for the particular frame size in EN 50347 (2001).

This table shows the requirements for protecting the motor insulation and bearings in drive systems for ABB random-wound motor series (for example, M3AA, M3AP and M3BP).

| Nominal AC supply voltage                | Requirement for         |   |  |                           |
|--|-------------------------|---|--|---------------------------|
|  | Motor insulation system | ABB du/dt and common mode filters, insulated N-end motor bearings |  |                           |
|  |                         | $P_n < 100 \text{ kW}$  | $100 \text{ kW} \leq P_n < 200 \text{ kW}$ | $P_n \geq 200 \text{ kW}$ |
|  |                         | $P_n < 140 \text{ hp}$  | $140 \text{ hp} \leq P_n < 268 \text{ hp}$ | $P_n \geq 268 \text{ hp}$ |
| $U_n \leq 500 \text{ V}$                 | Standard                | -   | + N  | + N + CMF                 |
| $500 \text{ V} < U_n \leq 600 \text{ V}$ | Standard                | + du/dt   | + du/dt + N                                | + du/dt + N + CMF         |
|  | Reinforced              | -   | + N  | + N + CMF                 |
| $600 \text{ V} < U_n \leq 690 \text{ V}$ | Reinforced              | + du/dt   | + du/dt + N                                | + du/dt + N + CMF         |

### Additional requirements for non-ABB high-output and IP23 motors

The rated output power of high-output motors is higher than what is stated for the particular frame size in EN 50347 (2001).

If you plan to use a non-ABB high-output motor or an IP23 motor, consider these additional requirements for protecting the motor insulation and bearings in drive systems:

- If motor power is below 350 kW: Equip the drive and/or motor with the filters and/or bearings according to the table below.
- If motor power is above 350 kW: Consult the motor manufacturer.

| Nominal AC supply voltage                | Requirement for   |   |   |
|--|---|---|---|
|  | Motor insulation system   | ABB du/dt and common mode filters, insulated N-end motor bearings           |   |
|  |   | $P_n < 100 \text{ kW}$ or frame size < IEC 315                              | $100 \text{ kW} < P_n < 350 \text{ kW}$ or IEC 315 < frame size < IEC 400 |
|  | $P_n < 134 \text{ hp}$ or frame size < NEMA 500                                       | $134 \text{ hp} < P_n < 469 \text{ hp}$ or NEMA 500 < frame size < NEMA 580 |   |
| $U_n \leq 420 \text{ V}$                 | Standard: $\hat{U}_{LL} = 1300 \text{ V}$   | + N or CMF  | + N or CMF  |
| $420 \text{ V} < U_n < 500 \text{ V}$    | Standard: $\hat{U}_{LL} = 1300 \text{ V}$   | + du/dt + (N or CMF)  | + N + du/dt + CMF   |
|  | Reinforced: $\hat{U}_{LL} = 1600 \text{ V}$ , 0.2 microsecond rise time               | + N or CMF  | + N or CMF  |
| $500 \text{ V} < U_n \leq 600 \text{ V}$ | Reinforced: $\hat{U}_{LL} = 1600 \text{ V}$   | + du/dt + (N or CMF)  | + N + du/dt + CMF   |
|  | Reinforced: $\hat{U}_{LL} = 1800 \text{ V}$   | + N or CMF  | + N + CMF   |
| $600 \text{ V} < U_n \leq 690 \text{ V}$ | Reinforced: $\hat{U}_{LL} = 1800 \text{ V}$   | + N + du/dt   | + N + du/dt + CMF   |
|  | Reinforced: $\hat{U}_{LL} = 2000 \text{ V}$ , 0.3 microsecond rise time <sup>1)</sup> | + N + CMF   | + N + CMF   |

<sup>1)</sup> If the intermediate DC circuit voltage of the drive is increased from the nominal level due to long term resistor braking cycles, check with the motor manufacturer if additional output filters are needed.

### Additional data for calculating the rise time and the peak line-to-line voltage

The diagrams below show the relative peak line-to-line voltage and rate of change of voltage as a function of the motor cable length. If you need to calculate the actual peak voltage and voltage rise time considering the actual cable length, proceed as follows:

- Peak line-to-line voltage: Read the relative  $\hat{U}_{LL}/U_n$  value from the diagram below and multiply it by the nominal supply voltage ( $U_n$ ).
- Voltage rise time: Read the relative values  $\hat{U}_{LL}/U_n$  and  $(du/dt)/U_n$  from the diagram below. Multiply the values by the nominal supply voltage ( $U_n$ ) and substitute into equation  $t = 0.8 \cdot \hat{U}_{LL}/(du/dt)$ .

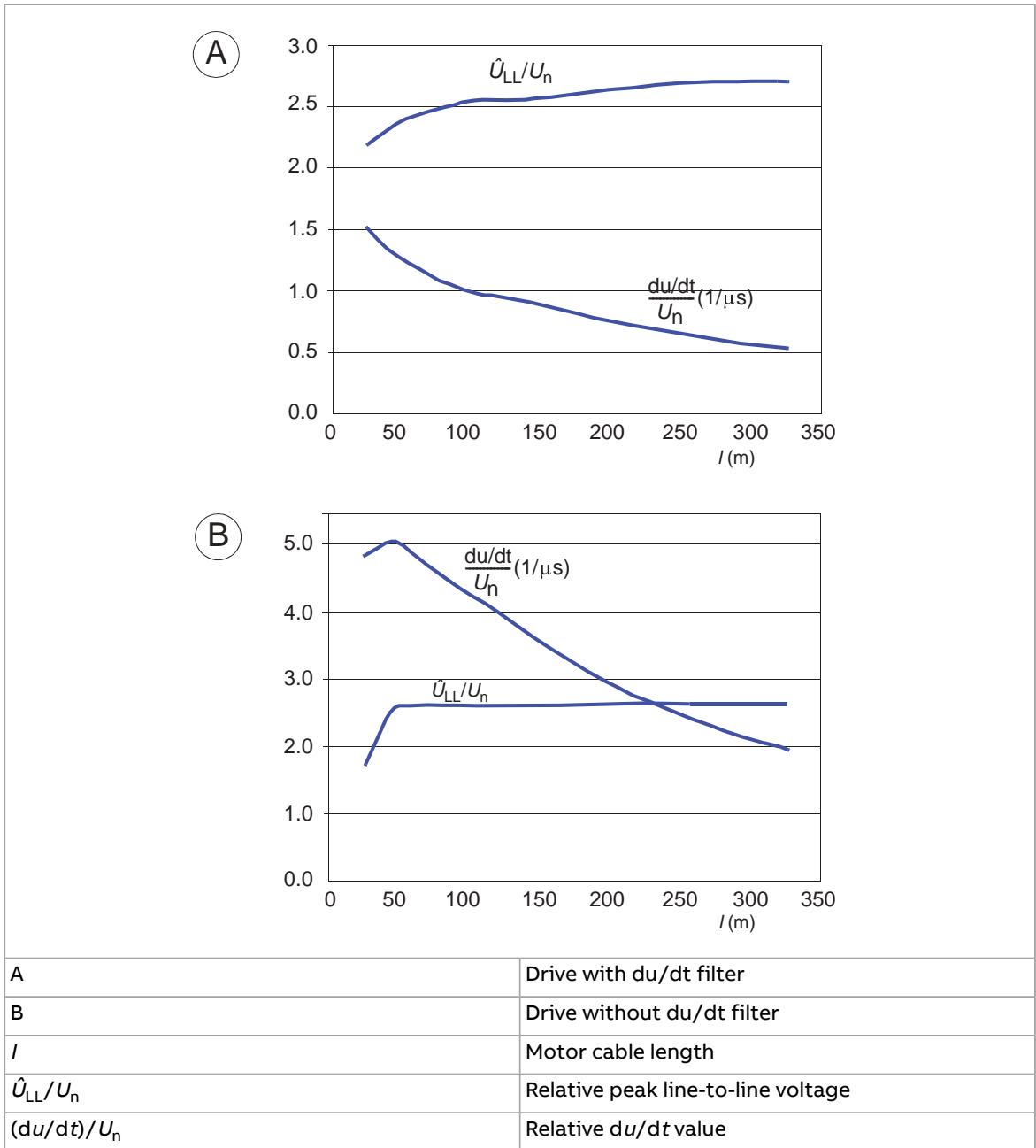

**Additional note for sine filters**

A sine filter also protects the motor insulation system. The peak phase-to-phase voltage with a sine filter is approximately  $1.5 \cdot U_n$ .

## Selecting the power cables

### ■ General guidelines

Select the input power and motor cables according to local regulations.

- **Current:** Select a cable capable of carrying the maximum load current and suitable for the prospective short-circuit current provided by the supply network. The method of installation and ambient temperature affect the cable current carrying capacity. Obey local regulations and laws.
- **Temperature:** For an IEC installation, select a cable rated for at least 70 °C (158 °F) maximum permissible temperature of conductor in continuous use. For North America, select a cable rated for at least 75 °C (167 °F).  
Important: For certain product types or option configurations higher temperature rating may be required. See the technical data for details.
- **Voltage:** 600 V AC cable is accepted for up to 500 V AC. 750 V AC cable is accepted for up to 600 V AC. 1000 V AC cable is accepted for up to 690 V AC.

To comply with the EMC requirements of the CE mark, use one of the preferred cable types. See [Preferred power cable types \(page 80\)](#).

Symmetrical shielded cable reduces electromagnetic emission of the whole drive system as well as the stress on motor insulation, bearing currents and wear.

Metal conduit reduces electromagnetic emission of the whole drive system.

### ■ Typical power cable sizes

See the technical data in the appropriate hardware manual.

### ■ Power cable types

#### Preferred power cable types

This section shows the preferred cable types. Make sure that the selected cable type also complies with local/state/country electrical codes.

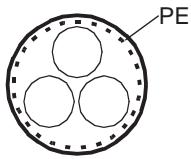
| Cable type  | Use as input power cabling | Use as motor cabling and as brake resistor cabling |
|---|----------------------------|--|
|  <p>Symmetrical shielded (or armored) cable with three phase conductors and concentric PE conductor as shield (or armor)</p> | Yes                        | Yes  |





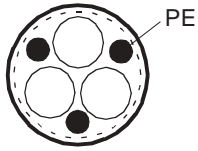
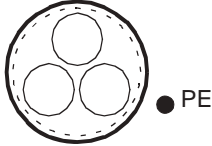

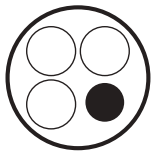

| Cable type   | Use as input power cabling | Use as motor cabling and as brake resistor cabling |
|--|----------------------------|--|
|  <p>Symmetrical shielded (or armored) cable with three phase conductors and symmetrically constructed PE conductor and a shield (or armor)</p>    | Yes                        | Yes  |
|  <p>Symmetrical shielded (or armored) cable with three phase conductors and a shield (or armor), and separate PE conductor/cable<sup>1)</sup></p> | Yes                        | Yes  |

<sup>1)</sup> A separate PE conductor is required if the conductivity of the shield (or armor) is not sufficient for the PE use.

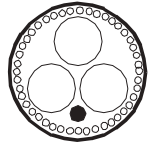
### Alternate power cable types

| Cable type  | Use as input power cabling   | Use as motor cabling and as brake resistor cabling   |
|---|--|--|
|  <p>Four-conductor cable in plastic jacket (three phase conductors and PE)</p>                               | Yes with phase conductor smaller than 10 mm <sup>2</sup> (8 AWG) Cu. | Yes with phase conductor smaller than 10 mm <sup>2</sup> (8 AWG) Cu, or motors up to 30 kW (40 hp).<br><b>Note:</b> Shielded or armored cable, or cabling in metal conduit is always recommended to minimize radio frequency interference. |
|  <p>Four-conductor armored cable (three phase conductors and PE)</p>   | Yes  | Yes with phase conductor smaller than 10 mm <sup>2</sup> (8 AWG) Cu, or motors up to 30 kW (40 hp)   |
|  <p>Shielded (Al/Cu shield or armor)<sup>1)</sup> four-conductor cable (three phase conductors and a PE)</p> | Yes  | Yes with motors up to 100 kW (135 hp). A potential equalization between the frames of motor and driven equipment is required.  |

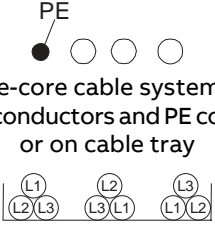

| Cable type  | Use as input power cabling   | Use as motor cabling and as brake resistor cabling |
|---|--|--|
|  <p>A single-core cable system: three phase conductors and PE conductor on cable tray</p> <p>Preferable cable arrangement to avoid voltage or current imbalance between the phases</p> | <p>Yes</p> <p> <b>WARNING!</b><br/>If you use unshielded single-core cables in an IT network, make sure that the non-conductive outer sheath (jacket) of the cables have good contact with a properly grounded conductive surface. For example, install the cables on a properly grounded cable tray. Otherwise voltage may become present on the non-conductive outer sheath of the cables, and there is even a risk of an electric shock.</p> | <p>No</p>  |

1) Armor may act as an EMC shield, as long as it provides the same performance as a concentric EMC shield of a shielded cable. To be effective at high frequencies, the shield conductivity must be at least 1/10 of the phase conductor conductivity. The effectiveness of the shield can be evaluated based on the shield inductance, which must be low and only slightly dependent on frequency. The requirements are easily met with a copper or aluminum shield/armor. The cross-section of a steel shield must be ample and the shield helix must have a low gradient. A galvanized steel shield has a better high-frequency conductivity than a non-galvanized steel shield.

**Not allowed power cable types**

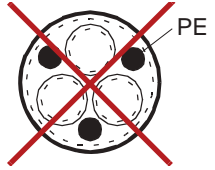
| Cable type   | Use as input power cabling | Use as motor cabling and as brake resistor cabling |
|--|----------------------------|--|
|  <p>Symmetrical shielded cable with individual shields for each phase conductor</p> | <p>No</p>                  | <p>No</p>  |

■ **Additional guidelines – North America**

ABB recommends the use of metallic conduit for power wiring. ABB also recommends the use of symmetrical shielded VFD cable between drive and motor(s).

This table shows examples of methods for wiring the drive. Refer to NFPA 70 (NEC) along with state and local codes for the appropriate methods for your application.

| Wiring method   | Notes   |
|---|---|
| Conduit - Metallic <sup>1) 2)</sup>                       |   |
| Electrical metallic tubing: Type EMT                      | Prefer symmetrical shielded VFD cable.  |
| Rigid metal conduit: Type RMC                             | Use separate conduit run for each motor.  |
| Liquid-tight flexible metal electrical conduit: Type LFMC | Do not run input power wiring and motor wiring in the same conduit.   |
| Conduit - Non-metallic <sup>2) 3)</sup>                   |   |
| Liquid-tight flexible non-metallic conduit: Type LFNC     | Prefer symmetrical shielded VFD cable.<br>Use separate conduit run for each motor.<br>Do not run input power wiring and motor wiring in the same conduit.   |
| Wireways <sup>2)</sup>                                    |   |
| Metallic  | Prefer symmetrical shielded VFD cable.<br>Separate motor wiring from input power wiring and other low voltage wiring.<br>Do not run outputs of multiple drives parallel. Bundle each cable (wiring) together and use separators where possible. |
| Free air <sup>2)</sup>                                    |   |
| Enclosures, air handlers, etc.                            | Prefer symmetrical shielded VFD cable.<br>Allowed internally in enclosures when in accordance with UL.  |

1) Metallic conduit may be used as an additional ground path, provided this path is a solid path capable of handling ground currents.

2) See NFPA 70 (NEC), UL, and local codes for your application.

3) Non-metallic conduit use underground is allowed; however, these installations inherently have an increased chance for nuisance problems due to the potential for water/moisture in the conduit. Water/moisture in the conduit increases the likelihood of VFD faults or warnings. Proper installation is required to make sure there is no intrusion of water/moisture.

## Metal conduit

Couple separate parts of a metal conduit together: bridge the joints with a ground conductor bonded to the conduit on each side of the joint. Also bond the conduits to the drive enclosure and motor frame. Use separate conduits for input power, motor, brake resistor, and control wiring. Do not run motor wiring from more than one drive in the same conduit.

### ■ Power cable shield

If the cable shield is used as the sole protective earth (PE) conductor, make sure that its conductivity agrees with the PE conductor requirements.

To effectively suppress radiated and conducted radio-frequency emissions, the cable shield conductivity must be at least 1/10 of the phase conductor conductivity. The requirements are easily met with a copper or aluminum shield. The minimum requirement of the motor cable shield of the drive is shown below. It consists of a concentric layer of copper wires with an open helix of copper tape or copper wire. The better and tighter the shield, the lower the emission level and bearing currents.

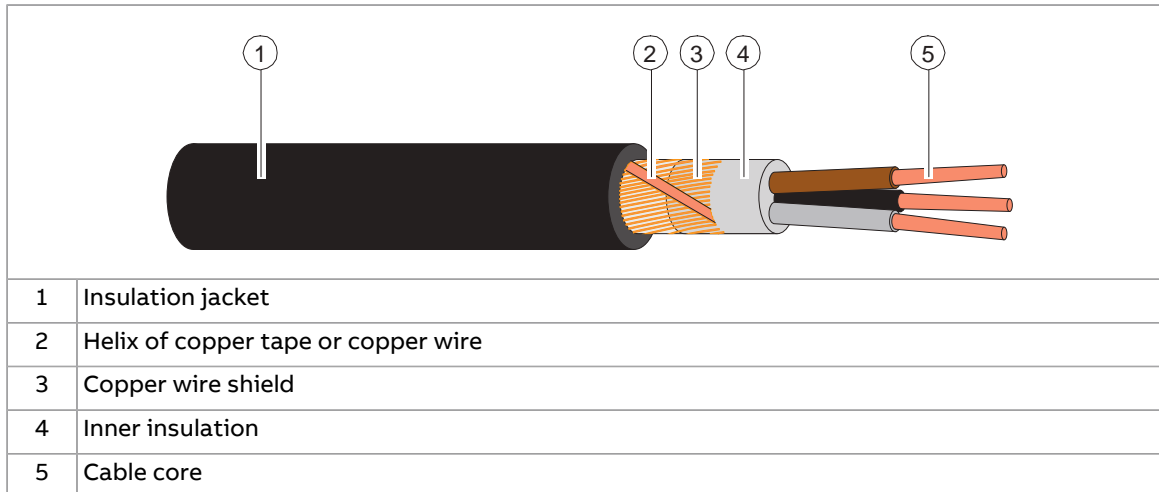

## Grounding requirements

This section gives general requirements for grounding the drive. When you plan the grounding of the drive, obey all the applicable national and local regulations.

The conductivity of the protective earth conductor(s) must be sufficient.

Unless local wiring regulations state otherwise, the cross-sectional area of the protective earth conductor must agree with the conditions that require automatic disconnection of the supply required in 411.3.2 of IEC 60364-4-41:2005 and be capable of withstanding the prospective fault current during the disconnection time of the protective device. The cross-sectional area of the protective earth conductor must be selected from the table below or calculated according to 543.1 of IEC 60364-5-54.

The table shows the minimum cross-sectional area of the protective earth conductor related to the phase conductor size according to IEC/UL 61800-5-1 when the phase conductor(s) and the protective earth conductor are made of the same metal. If they are different metals, the cross-sectional area of the protective earth conductor must be determined in a manner which produces a conductance equivalent to that which results from the application of this table.

| Cross-sectional area of the phase conductors<br>$S$ (mm <sup>2</sup> ) | Minimum cross-sectional area of the corresponding<br>protective earth conductor<br>$S_p$ (mm <sup>2</sup> ) |
|--|---|
| $S \leq 16$  | $S$ <sup>1)</sup>   |
| $16 < S \leq 35$   | 16  |
| $35 < S$   | $S/2$   |

<sup>1)</sup> For the minimum conductor size in IEC installations, refer to [Additional grounding requirements – IEC \(page 85\)](#).

If the protective earth conductor is not part of the input power cable or input power cable enclosure, the minimum permitted cross-sectional area is:

- 2.5 mm<sup>2</sup> if the conductor is mechanically protected,  
or
- 4 mm<sup>2</sup> if the conductor is not mechanically protected. If the equipment is cord-connected, the protective earth conductor must be the last conductor to be interrupted if there is a failure in the strain relief mechanism.

### ■ Additional grounding requirements – IEC

This section gives grounding requirements according to standard IEC/EN 61800-5-1.

Because the normal touch current of the drive is more than 3.5 mA AC or 10 mA DC:

- the minimum size of the protective earth conductor must comply with the local safety regulations for high protective earth conductor current equipment, and
- you must use one of these connection methods:
  1. a fixed connection and:
    - a protective earth conductor with a minimum cross-sectional area of 10 mm<sup>2</sup> Cu or 16 mm<sup>2</sup> Al (as an alternative when aluminum cables are permitted),
    - or
    - a second protective earth conductor of the same cross-sectional area as the original protective earth conductor,
    - or
    - a device that automatically disconnects the supply if the protective earth conductor is damaged.
  2. a connection with an industrial connector according to IEC 60309 and a minimum protective earth conductor cross-section of 2.5 mm<sup>2</sup> as part of a multi-conductor power cable. Sufficient strain relief must be provided.

If the protective earth conductor is routed through a plug and socket, or similar means of disconnection, it must not be possible to disconnect it unless power is simultaneously removed.

**Note:** You can use power cable shields as protective earth conductors only when their conductivity is sufficient.

### ■ Additional grounding requirements – UL (NEC)

This section gives grounding requirements according to standard UL 61800-5-1.

The protective earth conductor must be sized as specified in Article 250.122 and table 250.122 of the National Electric Code, ANSI/NFPA 70.

For cord-connected equipment, it must not be possible to disconnect the protective earth conductor before power is removed.

## Selecting the control cables

### ■ Shielding

Only use shielded control cables.

Use a double-shielded twisted pair cable for analog signals. ABB recommends this type of cable also for the pulse encoder signals. Use one individually shielded pair for each signal. Do not use common return for different analog signals.



A double-shielded cable (a) is the best alternative for low-voltage digital signals, but single-shielded (b) twisted pair cable is also acceptable.

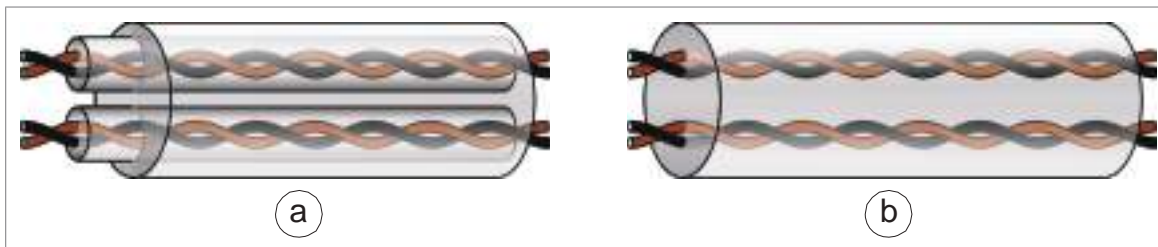

### ■ Signals in separate cables

Run analog and digital signals in separate, shielded cables. Do not mix 24 V DC and 115/230 V AC signals in the same cable.

### ■ Signals that can be run in the same cable

If their voltage does not exceed 48 V, relay-controlled signals can be run in the same cables as digital input signals. The relay-controlled signals should be run as twisted pairs.

### ■ Relay cable

The cable type with braided metallic shield (for example ÖLFLEX by LAPPKABEL, Germany) has been tested and approved by ABB.

### ■ Control panel to drive cable

Use EIA-485, Cat 5e (or better) cable with male RJ45 connectors. The maximum length of the cable is 100 m (328 ft).

### ■ PC tool cable

Connect the Drive Composer PC tool to the drive through the USB port of the control panel. Use a USB Type A (PC) - Type Mini-B (control panel) cable. The maximum length of the cable is 3 m (9.8 ft).

## Routing the cables

### ■ General guidelines – IEC

- Route the motor cable away from other cables. Motor cables of several drives can be run in parallel installed next to each other.
- Install the motor cable, input power cable and control cables on separate trays.
- Avoid long parallel runs of motor cables with other cables.
- Where control cables must cross power cables, make sure that they are arranged at an angle as near to 90 degrees as possible.
- Do not run extra cables through the drive.
- Make sure that the cable trays have good electrical bonding to each other and to the grounding electrodes. Aluminum tray systems can be used to improve local equalizing of potential.

The following figure illustrates the cable routing guidelines with an example drive.

**Note:** When motor cable is symmetrical and shielded and it has short parallel runs with other cables (< 1.5 m / 5 ft), distances between the motor cable and other cables can be reduced by half.

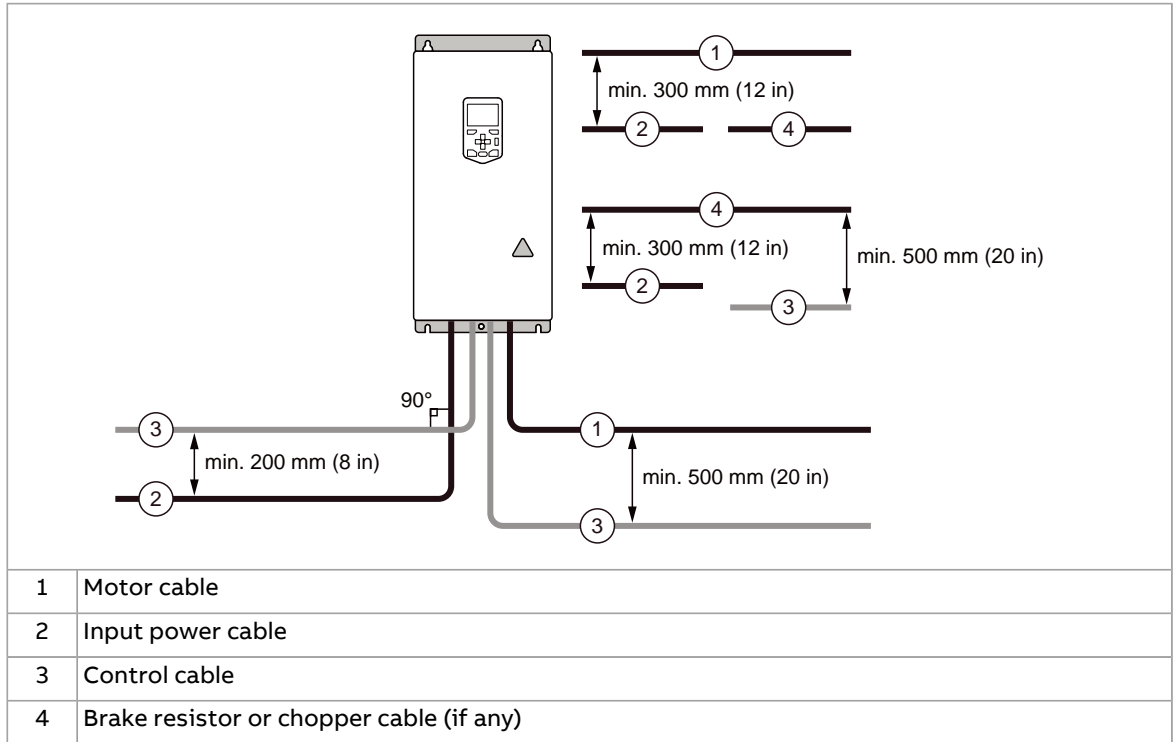

■ **General guidelines – North America**

Make sure that the installation is in accordance with national and local codes. Obey these general guidelines:

- Use separate conduits for the input power, motor, brake resistor (optional), and control cabling.
- Use separate conduit for each motor cabling.

The following figure illustrates the cable routing guidelines with an example drive.



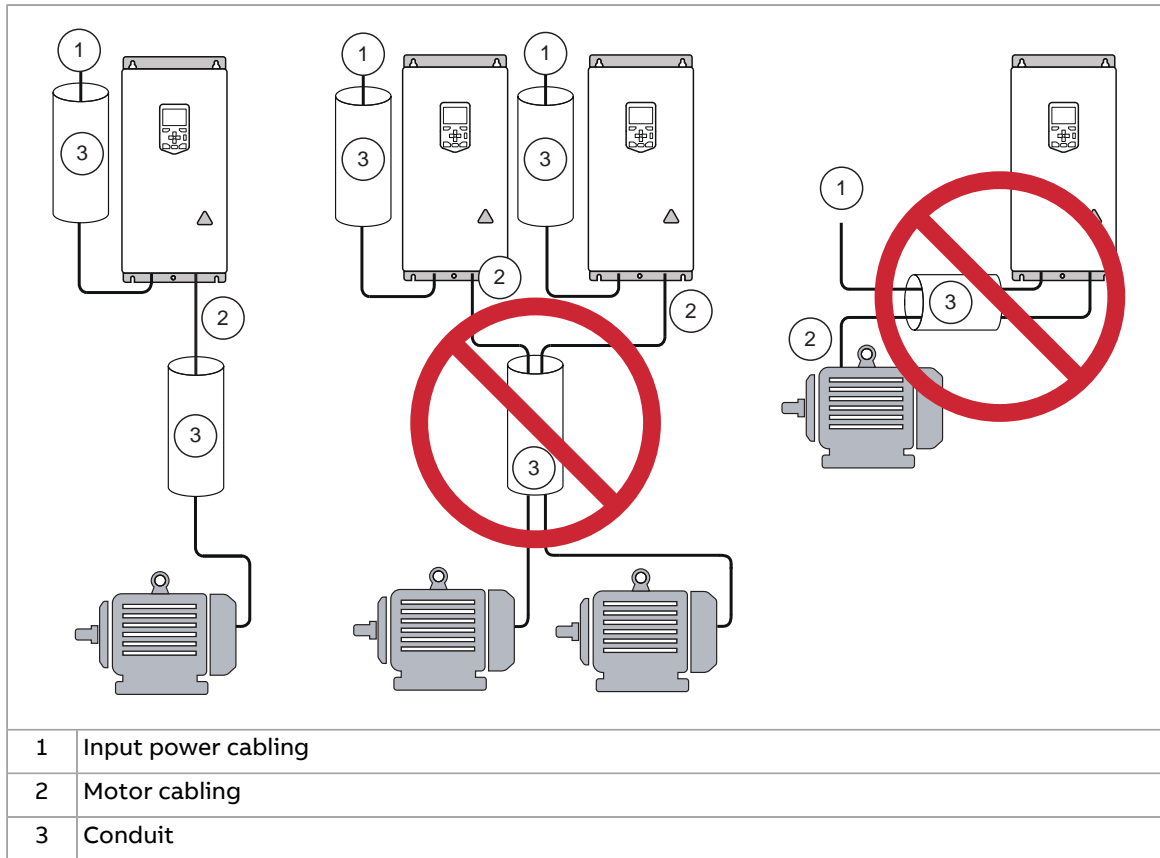

■ **Continuous motor cable shield/conduit and metal enclosure for equipment on the motor cable**

To minimize the emission level when safety switches, contactors, connection boxes or similar equipment are installed on the motor cable between the drive and the motor:

- Install the equipment in a metal enclosure.
- Use either a symmetrical shielded cable, or install the cabling in a metal conduit.
- Make sure that there is a good and continuous galvanic connection in the shield/conduit between drive and motor.
- Connect the shield/conduit to the protective ground terminal of the drive and the motor.

■ **Separate control cable ducts**

Put 24 V DC and 230 V AC (120 V AC) control cables in separate ducts, unless the 24 V DC cable is insulated for 230 V AC (120 V AC) or insulated with an insulation sleeving for 230 V AC (120 V AC).

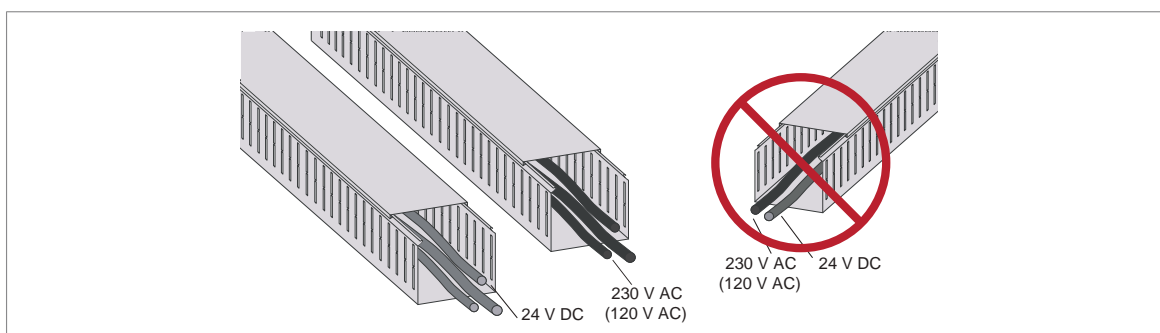



## Protecting the drive, input power cable, motor and motor cable in short circuit situations and against thermal overload

### ■ Protecting the drive and input power cable in short-circuit situations

The drive is equipped with internal AC fuses (1) as standard. The fuses restrict drive damage and prevent damage to adjoining equipment in case of a short-circuit inside the drive.

Protect the input cable with fuses or circuit breaker (2) according to local safety regulations, appropriate input voltage and the rated current of the drive (see chapter [Technical data \(page 191\)](#)).

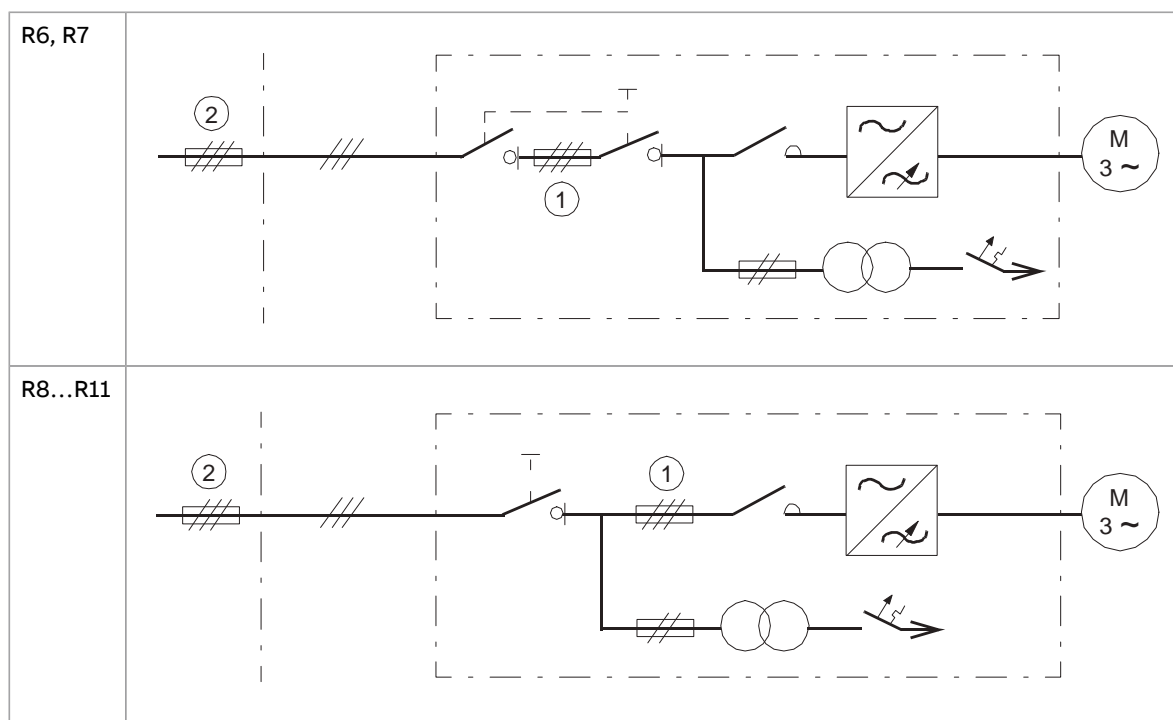

### ■ Protecting the motor and motor cable in short-circuits

The drive protects the motor cable and motor in a short-circuit situation when:

- the motor cable is sized correctly
- the motor cable type complies with the motor cable selection guidelines by ABB
- the cable length does not exceed the allowed maximum length specified for the drive
- the setting of parameter 99.10 Motor nominal power in the drive is equal with the value given on the motor rating plate.

The electronic power output short-circuit protection circuitry meets the requirements of IEC 60364-4-41:2005 + AMD1:2017.

### ■ Protecting the drive and the power cables against thermal overload

The drive protects itself and the input and motor cables against thermal overload when the cables are sized according to the nominal current of the drive. No additional thermal protection devices are needed.



**WARNING!**

If the drive is connected to multiple motors, use a separate circuit breaker or fuses for protecting each motor cable and motor against overload. The drive overload protection is tuned for the total motor load. It may not trip due to an overload in one motor circuit only.

---

■ **Protecting the motor against thermal overload**

According to regulations, the motor must be protected against thermal overload and the current must be switched off when overload is detected. The drive includes a motor thermal protection function that protects the motor and switches off the current when necessary. Depending on a drive parameter value, the function either monitors a calculated temperature value (based on a motor thermal model) or an actual temperature indication given by motor temperature sensors.

The motor thermal protection model supports thermal memory retention and speed sensitivity. The user can tune the thermal model further by feeding in additional motor and load data.

The most common temperature sensor types are PTC or Pt100.

For more information, see the firmware manual.

■ **Protecting the motor against overload without thermal model or temperature sensors**

Motor overload protection protects the motor against overload without using motor thermal model or temperature sensors.

Motor overload protection is required and specified by multiple standards including the US National Electric Code (NEC) and the common UL/IEC 61800-5-1 standard in conjunction with UL/IEC 60947-4-1. The standards allow for motor overload protection without external temperature sensors.

The protection feature of the drive allows the user to specify the class of operation in the same manner as the overload relays are specified in standards UL/IEC 60947-4-1 and NEMA ICS 2.

The motor overload protection supports thermal memory retention and speed sensitivity.

For more information, see drive firmware manual.

## **Protecting the drive against ground faults**

The drive is equipped with an internal ground fault protective function to protect the unit against ground faults in the motor and motor cable. This function is not a personnel safety or a fire protection feature. See the firmware manual for more information.

■ **Residual current device compatibility**

The drive is suitable for use with residual current devices of Type B.

**Note:** As standard, the drive contains capacitors connected between the main circuit and the frame. These capacitors and long motor cables increase the ground leakage current and may cause nuisance faults in residual current devices.

---

## Implementing the emergency stop function

You can order the drive with an emergency stop function (option).

See the appropriate option manual for more information.

| Option code | User's manual  | Manual code (English) |
|-------------|--|-----------------------|
| +Q951       | Emergency stop, stop category 0 (option +Q951) for ACS580-07, ACH580-07 and ACQ580-07 drives user's manual   | 3AXD50000171828       |
| +Q963       | Emergency Stop, Category 0 (option +Q963) without opening main contactor with safety relay for ACS580-07, ACH580-07 and ACQ580-07 drives user's manual | 3AXD50000171835       |

## Implementing the Safe torque off function

See chapter [The Safe torque off function \(page 269\)](#).

## Implementing the power loss ride-through function

If the incoming supply voltage is cut off, the drive will continue to operate by utilizing the kinetic energy of the rotating motor. The drive will be fully operational as long as the motor rotates and generates energy to the drive.

If the drive is equipped with a main contactor (option +F250), it restores the drive input power after a short break. The power supply for the contactor control circuit is buffered. It keeps the contactor closed in short power-loss situations. If the drive is equipped an external uninterruptible auxiliary power supply (option +G307), it keeps the main contactor closed in power-loss situations.

**Note:** If the power loss lasts so long that the drive trips on undervoltage, a fault reset and a fresh start command is required to continue operation.

Implement the power-loss ride-through function as follows:

1. Enable the power-loss ride-through function of the drive (parameter 30.31).
2. Enable the automatic restart of the motor after a short power supply break:
  - Set the start mode to automatic (parameter 21.01 or 21.19, depending on the motor control mode being used).
  - Define the automatic restart time (parameter 21.18).



### **WARNING!**

Make sure that a flying restart of the motor will not cause any danger. If you are in doubt, do not implement the power loss ride-through function.

## Using power factor compensation capacitors with the drive

Power factor compensation is not needed with AC drives. However, if a drive is to be connected in a system with compensation capacitors installed, note the following restrictions.

**WARNING!**

Do not connect power factor compensation capacitors or harmonic filters to the motor cables (between the drive and the motor). They are not meant to be used with AC drives and can cause permanent damage to the drive or themselves.

If there are power factor compensation capacitors in parallel with the input of the drive:

1. Do not connect a high-power capacitor to the power line while the drive is connected. The connection will cause voltage transients that may trip or even damage the drive.
2. If capacitor load is increased/decreased step by step when the AC drive is connected to the power line, make sure that the connection steps are low enough not to cause voltage transients that would trip the drive.
3. Make sure that the power factor compensation unit is suitable for use in systems with AC drives, ie, harmonic generating loads. In such systems, the compensation unit should typically be equipped with a blocking reactor or harmonic filter.

## Using a safety switch between the drive and the motor

ABB recommends to install a safety switch between the permanent magnet motor and the drive output. The switch is needed to isolate the motor from the drive during maintenance work on the drive.

## Implementing an ATEX-certified motor thermal protection

With option +Q971, the drive provides ATEX-certified safe motor disconnection without contactor using the drive Safe torque off function. To implement the thermal protection of a motor in explosive atmosphere (Ex motor), you must also:

- use an ATEX-certified Ex motor
- order an ATEX-certified thermistor protection module for the drive (option +L537), or acquire and install an ATEX-compliant protection relay
- do the necessary connections.

For more information, see:

| User's manual   | Manual code (English)           |
|---|---------------------------------|
| CPTC-02 ATEX-certified thermistor protection module, Ex II (2) GD (option +L537+Q971) user's manual                   | <a href="#">3AXD50000030058</a> |
| CPTC-02 ATEX-certified thermistor protection module, instructions for pairing the module with an ATEX-certified drive | <a href="#">3AXD10001243391</a> |

## Controlling a contactor between drive and motor

The control of the output contactor depends on how you use the drive, that is, which motor control mode and which motor stop mode you select.

If you have the vector control mode and motor ramp stop selected, open the contactor as follows:

1. Give a stop command to the drive.
2. Wait until the drive decelerates the motor to zero speed.
3. Open the contactor.

If you have the vector control mode and motor coast stop selected, or scalar control mode selected, open the contactor as follows:

1. Give a stop command to the drive.
2. Open the contactor.



**WARNING!**

When the vector control mode is in use, never open the output contactor while the drive controls the motor. The vector control operates extremely fast, much faster than it takes for the contactor to open its contacts. When the contactor starts opening while the drive controls the motor, the vector control will try to maintain the load current by immediately increasing the drive output voltage to the maximum. This will damage, or even burn, the contactor completely.

---

## Implementing a bypass connection

If bypassing is required, employ mechanically or electrically interlocked contactors between the motor and the drive and between the motor and the power line. Make sure with interlocking that the contactors cannot be closed simultaneously. The installation must be clearly marked as defined in IEC/EN/UL 61800-5-1, subclause 6.5.3, for example, "THIS MACHINE STARTS AUTOMATICALLY".

Bypass connection is available as a factory-installed option for some cabinet-installed drive types. Consult ABB for more information.



**WARNING!**

Never connect the drive output to the electrical power network. The connection may damage the drive.

---

## Protecting the contacts of relay outputs

Inductive loads (relays, contactors, motors) cause voltage transients when switched off.

Install the protective component as close to the inductive load as possible. Do not install protective components at the relay outputs.

---



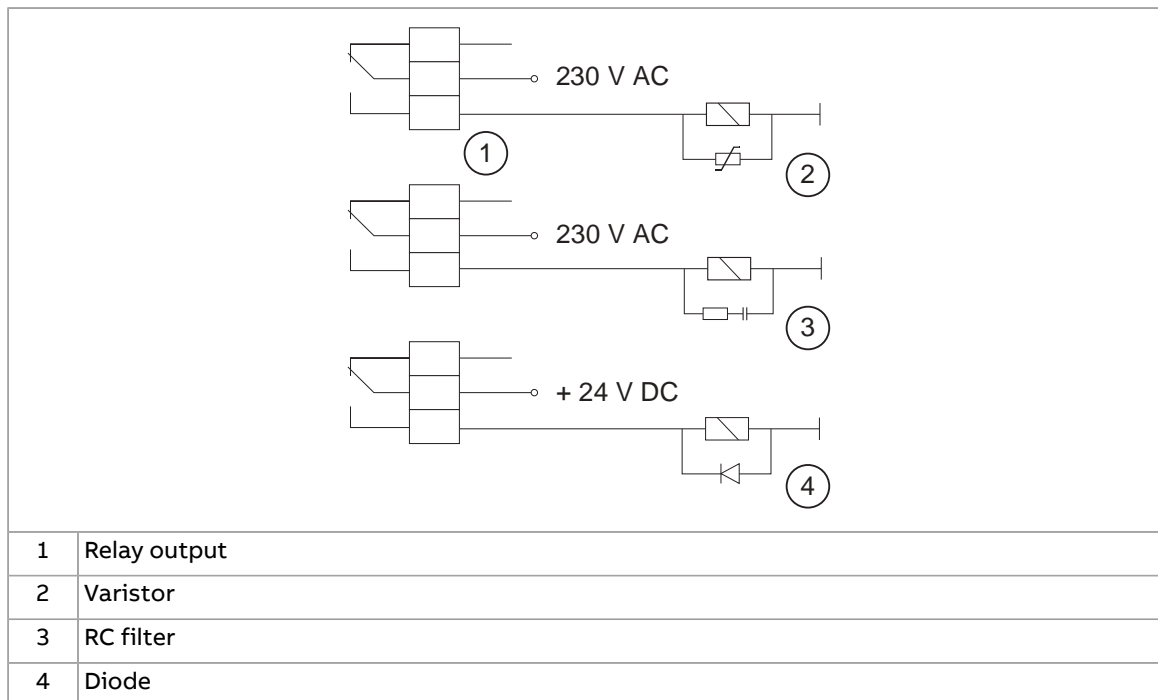

## Implementing a motor temperature sensor connection



### WARNING!

IEC 61800-5-1 requires double or reinforced insulation between live parts and accessible parts when:

- the accessible parts are not conductive, or
- the accessible parts are conductive, but not connected to the protective earth.

Obey this requirement when you plan the connection of the motor temperature sensor to the drive.

You have these implementation alternatives:

1. If there is double or reinforced insulation between the sensor and the live parts of the motor: You can connect the sensor directly to the analog/digital input(s) of the drive. See the control cable connection instructions. Make sure that the voltage is not more than the maximum allowed voltage over the sensor.
2. If there is basic insulation between the sensor and the live parts of the motor, or if the insulation type is not known: You can connect the sensor to the drive via an option module. The sensor and the module must form a double or reinforced insulation between the motor live parts and the drive control unit. See [Connecting a motor temperature sensor to the drive through an option module \(page 95\)](#). Make sure that the voltage does not exceed the maximum allowed voltage over the sensor.
3. If there is basic insulation between the sensor and the live parts of the motor, or if the insulation type is not known: You can connect a sensor to a digital input of the drive via an external relay. The sensor and the relay must form a double or reinforced insulation between the motor's live parts and the digital input of the drive. Make sure that the voltage does not exceed the maximum allowed voltage over the sensor.

## ■ Connecting a motor temperature sensor to the drive through an option module

This table shows:

- option module types that you can use for the motor temperature sensor connection
- insulation or isolation level that each option module forms between its temperature sensor connector and other connectors
- temperature sensor types that you can connect to each option module
- temperature sensor insulation requirement in order to form, together with the insulation of the option module, a reinforced insulation between the motor live parts and the drive control unit.

| Option module |  | Temperature sensor type |     |               | Temperature sensor insulation requirement |
|---------------|--|-------------------------|-----|---------------|---|
| Type          | Insulation/Isolation   | PTC                     | KTY | Pt100, Pt1000 |   |
| CMOD-02       | Reinforced insulation between the sensor connector and other connectors (including drive control unit connector).<br>The drive control unit is PELV compatible also when the module and a thermistor protection circuit are installed. | x                       | -   | -             | No special requirement                    |
| CPTC-02       |  | x                       | -   | -             | No special requirement                    |

For more information, refer to

- [Connecting motor temperature sensors to the drive \(page 136\)](#)
- [CMOD-02 multifunction extension module \(external 24 V AC/DC and isolated PTC interface\) \(page 311\)](#)
- [CPTC-02 ATEX-certified thermistor protection module, Ex II \(2\) GD \(option +L537+Q971\) user's manual \(3AXD50000030058 \[English\]\).](#)

## Supplying power for the auxiliary circuits

The user must supply these options from external power sources:

- +G300: Cabinet heaters
- +G307: Connection for an external uninterruptible power supply
- +G313: Power supply connection for a motor space heater output

For the voltages and fuse sizes, refer to the circuit diagrams delivered with the drive.







# 6

## Electrical installation

---

### Contents of this chapter

This chapter gives instructions on the wiring of the drive.

### Safety

---

**WARNING!**

If you are not a qualified electrical professional, do not do installation or maintenance work. Obey the safety instructions of the drive. If you ignore them, injury or death, or damage to the equipment can occur.

---

### Attaching the device stickers on the cabinet door

Attach the supplied multilingual device stickers over the English labels. Refer to [Door switches and lights \(page 44\)](#).



## Layout of the cable entries (frames R6...R9)

The layout of the input and motor cable connection terminals of frame R9 bottom entry without du/dt filter option (+E205) is shown below. The shrouds in front of the terminals have been removed. The layout is similar for the other frame sizes.

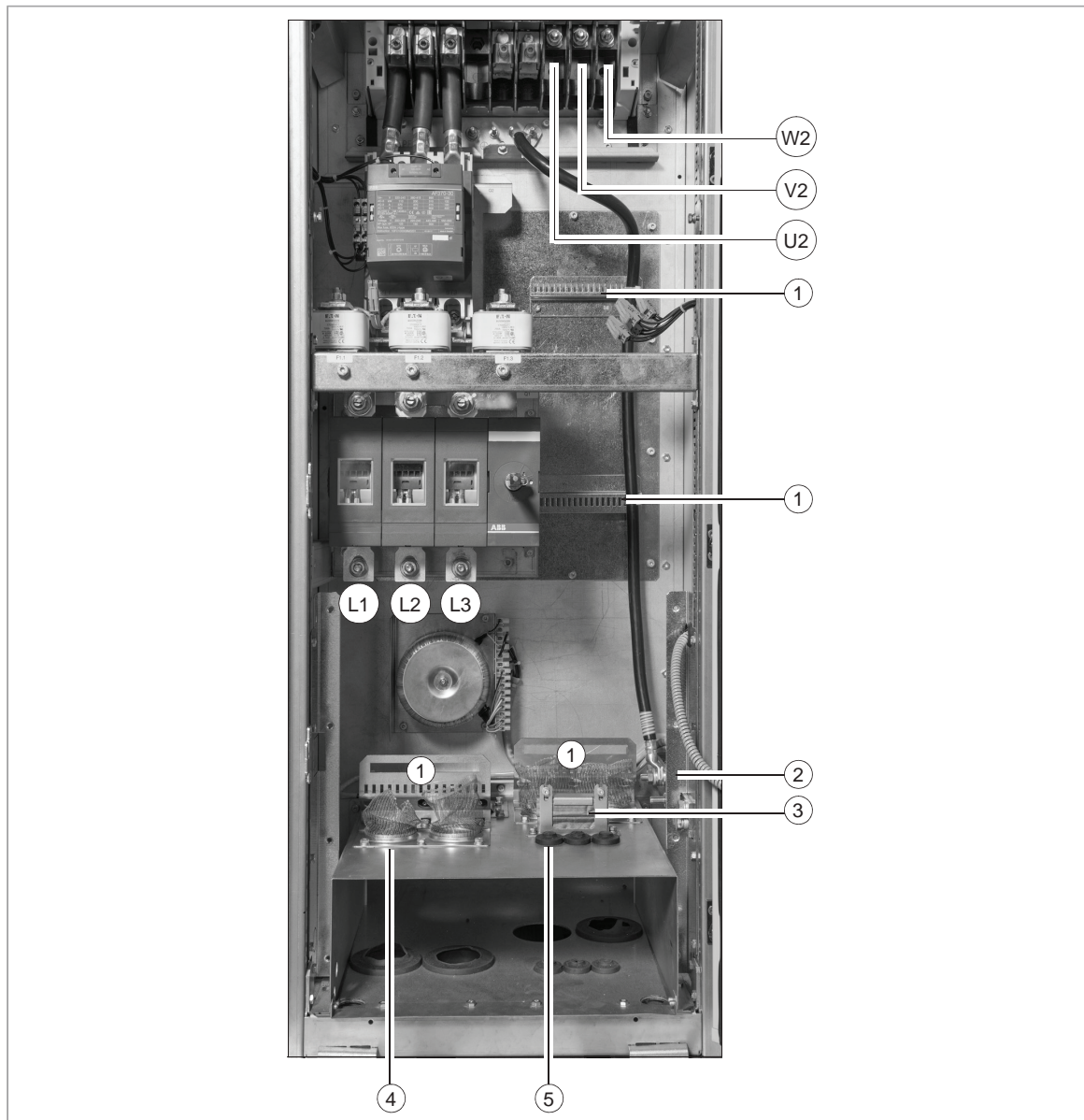

|            |   |
|------------|---|
| L1, L2, L3 | Input power cable terminals   |
| U2, V2, W2 | Motor cable terminals   |
| 1          | Strain relief   |
| 2          | PE (ground) terminal  |
| 3          | EMI-conductive cushion for grounding of the outer shields of the control cables |
| 4          | Power cable entry   |
| 5          | Control cable entry   |

## Layout of the cable entries (frames R10 and R11)

The layout of the input and motor cable connection terminals of frame R10 bottom entry is shown below. The shrouds in front of the terminals are removed. The layout is similar for frame R11.

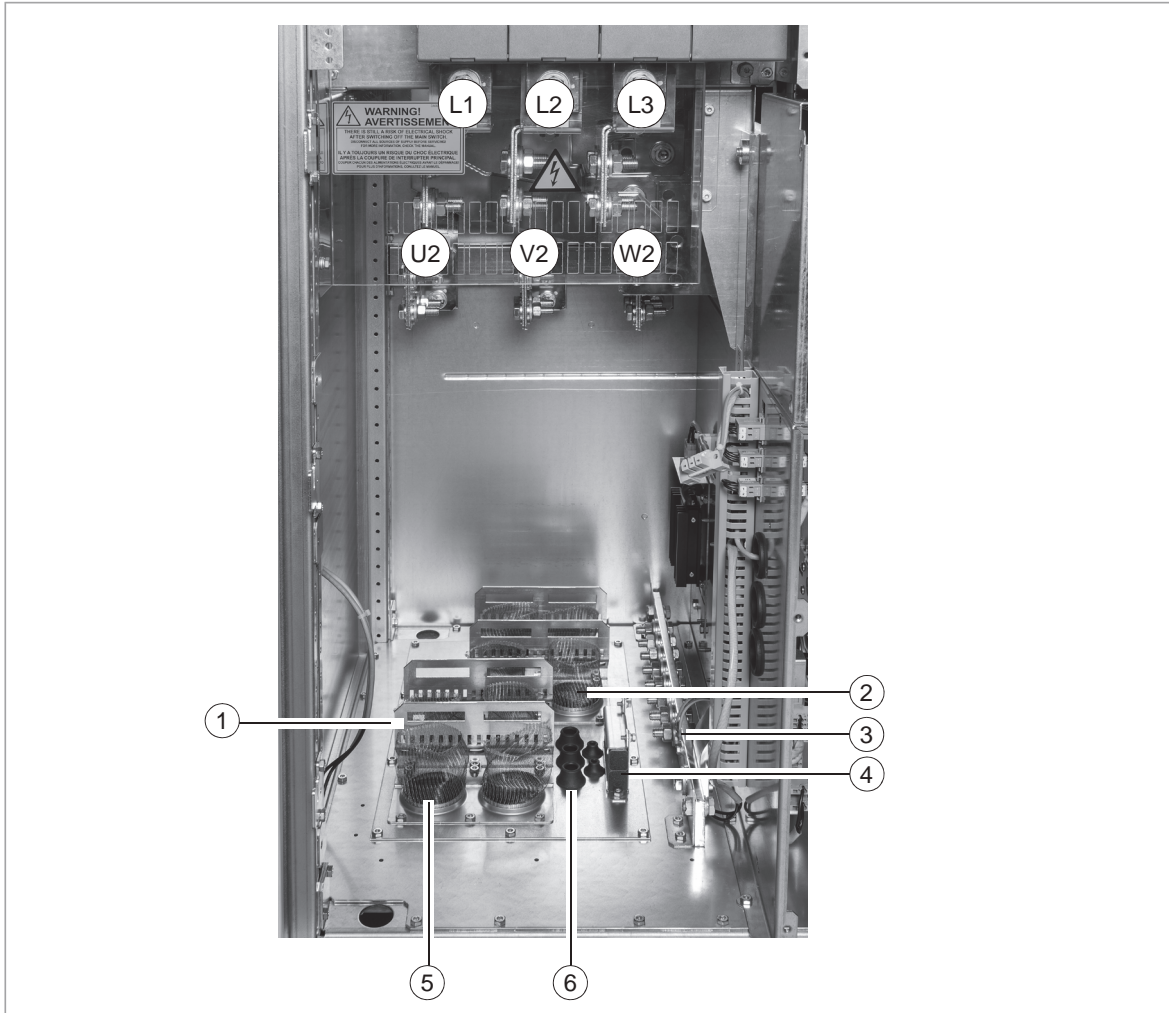

|            |   |
|------------|---|
| L1, L2, L3 | Input power cable terminals   |
| U2, V2, W2 | Motor cable terminals   |
| 1          | Strain relief   |
| 2          | Input power cable entry   |
| 3          | PE (ground) terminal  |
| 4          | EMI-conductive cushion for grounding of the outer shields of the control cables |
| 5          | Motor cable entry   |
| 6          | Control cable entry   |

## Connecting the motor cable at the motor end

Connect the power cables at the motor end.

For minimum radio-frequency interference, ground the cable shield 360° at the cable entry of the motor terminal box.

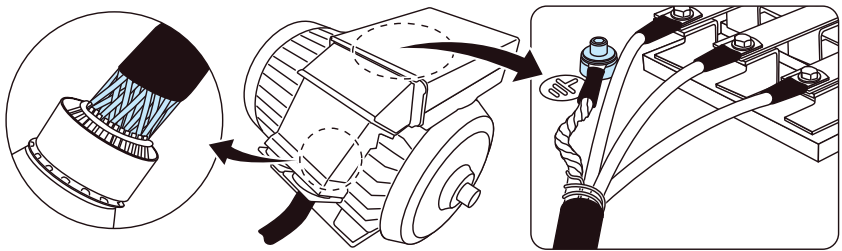

## Measuring the insulation

### ■ Measuring the insulation resistance of the drive



**WARNING!**

Do not do voltage withstand or insulation resistance tests on the drive. The tests can cause damage to the drive. Every drive is tested for insulation between the main circuit and the chassis at the factory. Also, there are voltage-limiting circuits inside the drive which cut down the testing voltage automatically.

### ■ Measuring the insulation resistance of the input power cable

Before you connect the input power cable to the drive, measure its insulation resistance according to local regulations.

### ■ Measuring the insulation resistance of the motor and motor cable



**WARNING!**

Obey the safety instructions of the drive. If you ignore them, injury or death, or damage to the equipment can occur. If you are not a qualified electrical professional, do not do installation, commissioning or maintenance work.

1. Do the steps in section [Electrical safety precautions \(page 18\)](#) before you start the work.
2. Make sure that the motor cable is disconnected from the drive output terminals.
3. Measure the insulation resistance between each phase conductor and the protective earth conductor. Use a measuring voltage of 1000 V DC. The insulation resistance of an ABB motor must be more than 100 Mohm (reference value at 25 °C [77 °F]). For the insulation resistance of other motors, refer to the manufacturer’s instructions.

**Note:** Moisture inside the motor reduces the insulation resistance. If you think that there is moisture in the motor, dry the motor and do the measurement again.

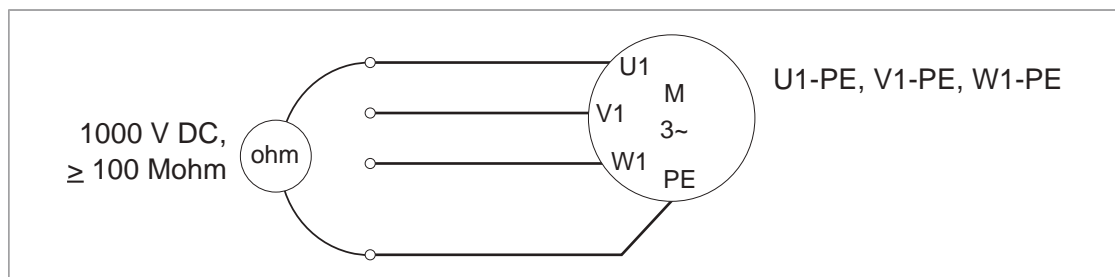

## Grounding system compatibility check

The standard drive can be installed to a symmetrically grounded TN-S system. If you install the drive to another system, you may need to disconnect the EMC filter and ground-to-phase varistor. See sections [When to disconnect the ground-to-phase varistor: TN-S, IT, corner-grounded delta, midpoint-grounded delta and TT systems \(page 287\)](#), [Disconnecting the EMC filter and ground-to-phase varistor \(IEC frames R6...R9\) \(page 290\)](#) and [Disconnecting the ground-to-phase varistor \(frames R10 and R11\) \(page 291\)](#).



### WARNING!

Do not install the drive with the EMC filter connected to a system that the filter is not suitable for. This can cause danger or damage the drive.



### WARNING!

Do not install the drive with the ground-to-phase varistor connected to a system that the varistor is not suitable for. If you do, the varistor circuit can be damaged.

### ■ EMC filter option +E202

A drive with EMC filter option +E202 connected can be installed to a symmetrically grounded TN-S system.



### WARNING!

Do not install a drive equipped with EMC filter option +E202 connected to a system that the filter is not suitable for. This can cause danger, or damage the drive.

**Note:** When EMC filter +E202 is disconnected, the drive EMC compatibility is considerably reduced.

## Connecting the power cables

### ■ Preparing the cable ends and making 360° grounding at the cable entry



### WARNING!

Obey the safety instructions of the drive. If you ignore them, injury or death, or damage to the equipment can occur.

1. Do the steps in section [Electrical safety precautions \(page 18\)](#) before you start the work.
2. Peel off 3...5 cm (1 1/4 ... 2 in) of the outer insulation of the cables at the cable entries with the conductive sleeves for the 360° high-frequency grounding.



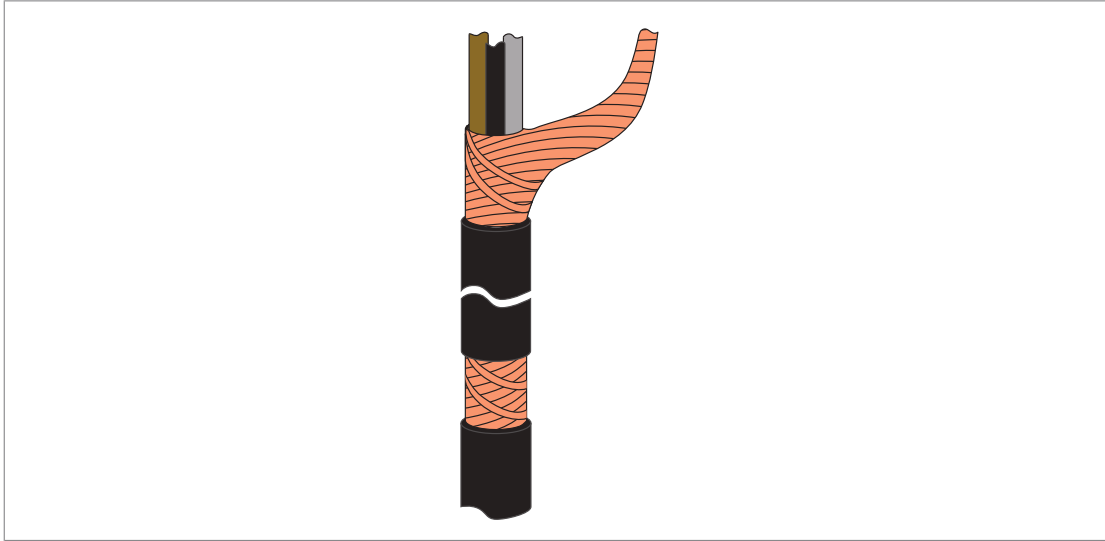

3. Prepare the ends of the cables.

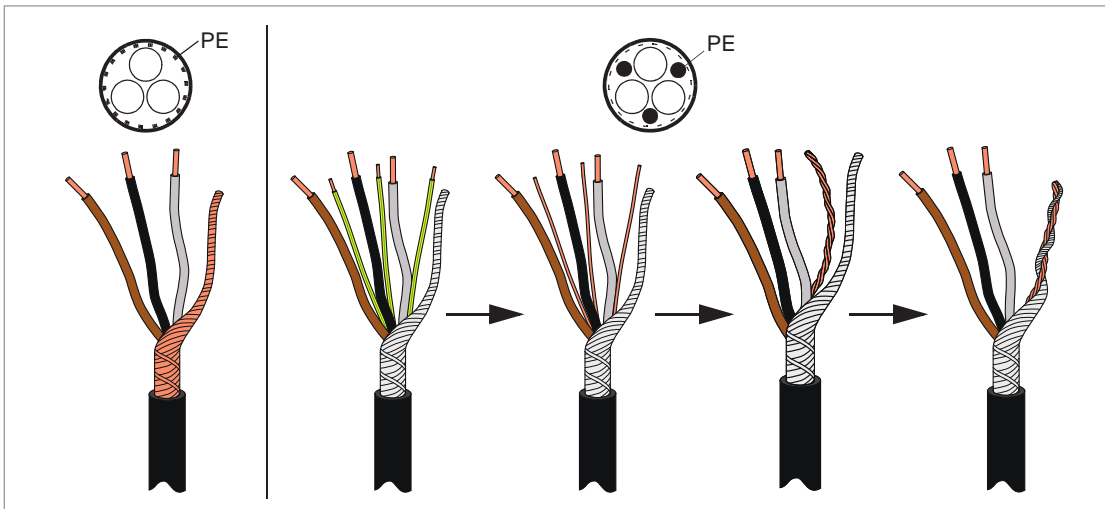

4. Put the cables through the entry plate. If the entry holes have rubber grommets, use one grommet for each cable. Cut adequate hole into the grommet and put the cable through the grommet inside the cabinet.

5. Attach the conductive sleeves to the cable shields with cable ties. Tie up the unused conductive sleeves with cable ties. An example of bottom entry is shown below. For top entry, put the grommet upwards.



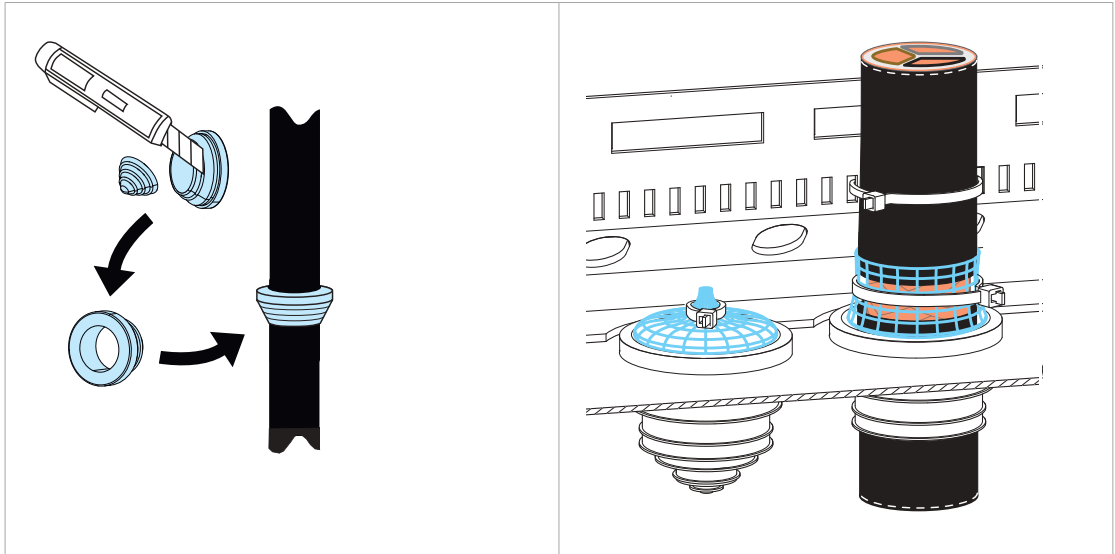

■ Connection diagram

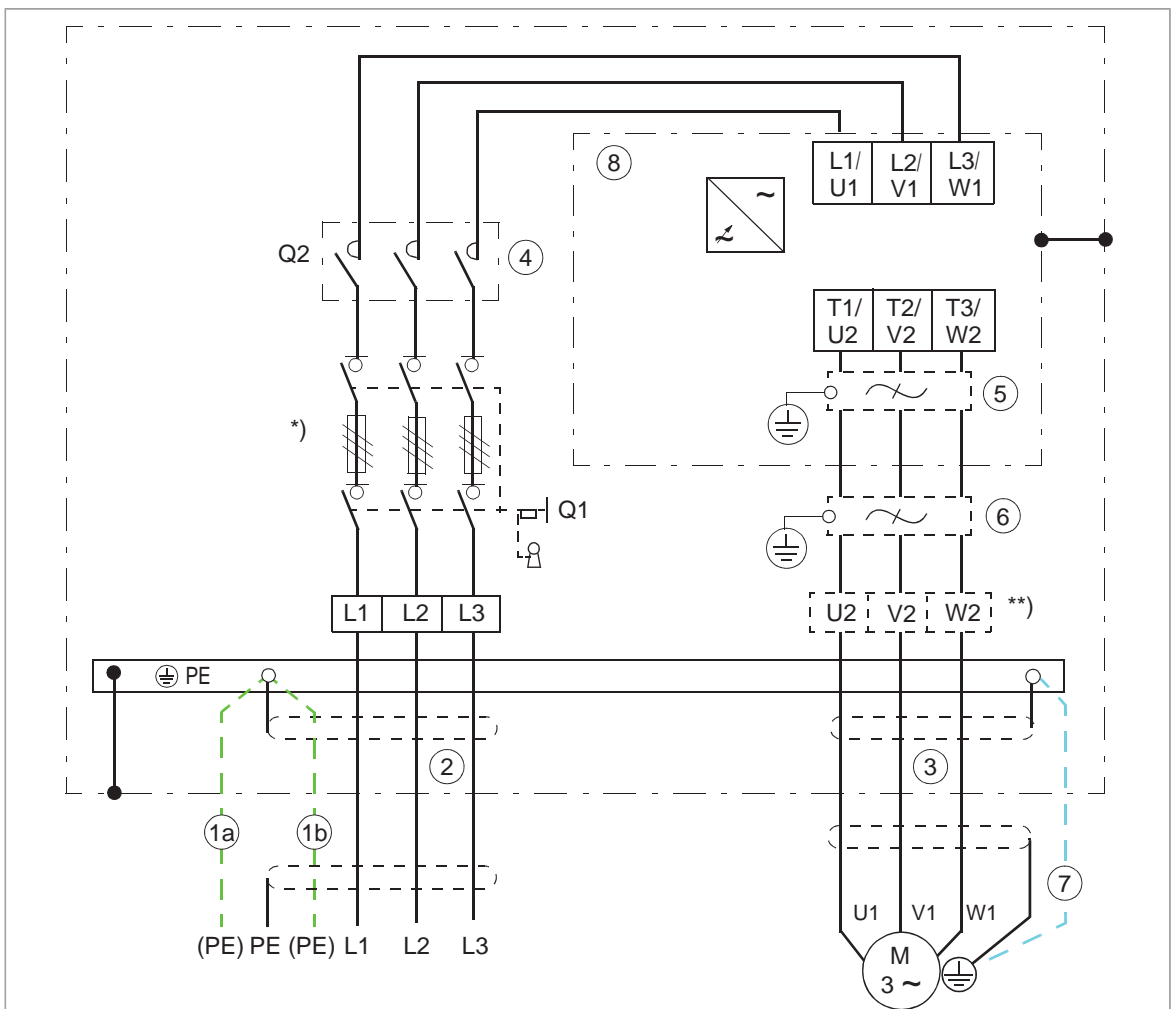

- |   |  |
|---|--|
| 1 | Use a separate grounding PE cable (1a) or a cable with a separate PE conductor (1b) if the conductivity of the shield does not meet the requirements for the PE conductor. |
| 2 | 360° grounding is recommended if shielded cable is used. Ground the other end of the input cable shield or PE conductor at the distribution board.                         |
| 3 | 360° grounding is required.  |

## 104 Electrical installation

|   |  |
|---|--|
| 4 | Line contactor (option +F250)  |
| 5 | Common mode filter (option +E208 for frames R6 to R9). Standard in frames R10 and R11.   |
| 6 | du/dt filter (option +E205)  |
| 7 | Use a separate grounding cable if the shield does not meet the requirements of IEC 61439-1 and there is no symmetrically constructed grounding conductor in the cable. |
| 8 | Drive module   |

**Note:** If there is a symmetrically constructed grounding conductor on the motor cable in addition to the conductive shield, connect the grounding conductor to the grounding terminal at the drive and motor ends.

Do not use an asymmetrically constructed motor cable. Connecting its fourth conductor at the motor end increases bearing currents and causes extra wear.

\*) Switch-disconnector or molded case circuit breaker (option +F289) and separate fuses in frames R8 to R11.

\*\*) Output terminals U2, V2 and W2 are included with option +E205 and in frames R10 and R11.





## ■ Connection procedure (frames R6...R9)

This section applies to drives with bottom entry and exit of power cables.

1. Do the steps in section [Electrical safety precautions \(page 18\)](#) before you start the work.
2. Open the cabinet door.
3. For drives without option +E205: To remove the mounting plate, undo the mounting screws and unplug the connectors on top of it:
  - auxiliary voltage supply connectors X23, X22 and X21
  - contactor control connectors: X3, X6
  - contactor feedback connector X250 with option +F250
  - cabinet door fan supply connector X8 and control X505
  - cabinet heater connector X300 with option +G300.
4. For drives without option +E205: Remove the shrouds (4a, 4b, 4c and 4d). To remove the shroud on the power cable terminals, release the clips with a screwdriver and pull the shroud out (4d).

For drives with option +E205: Remove the shrouds 4a, 4b.

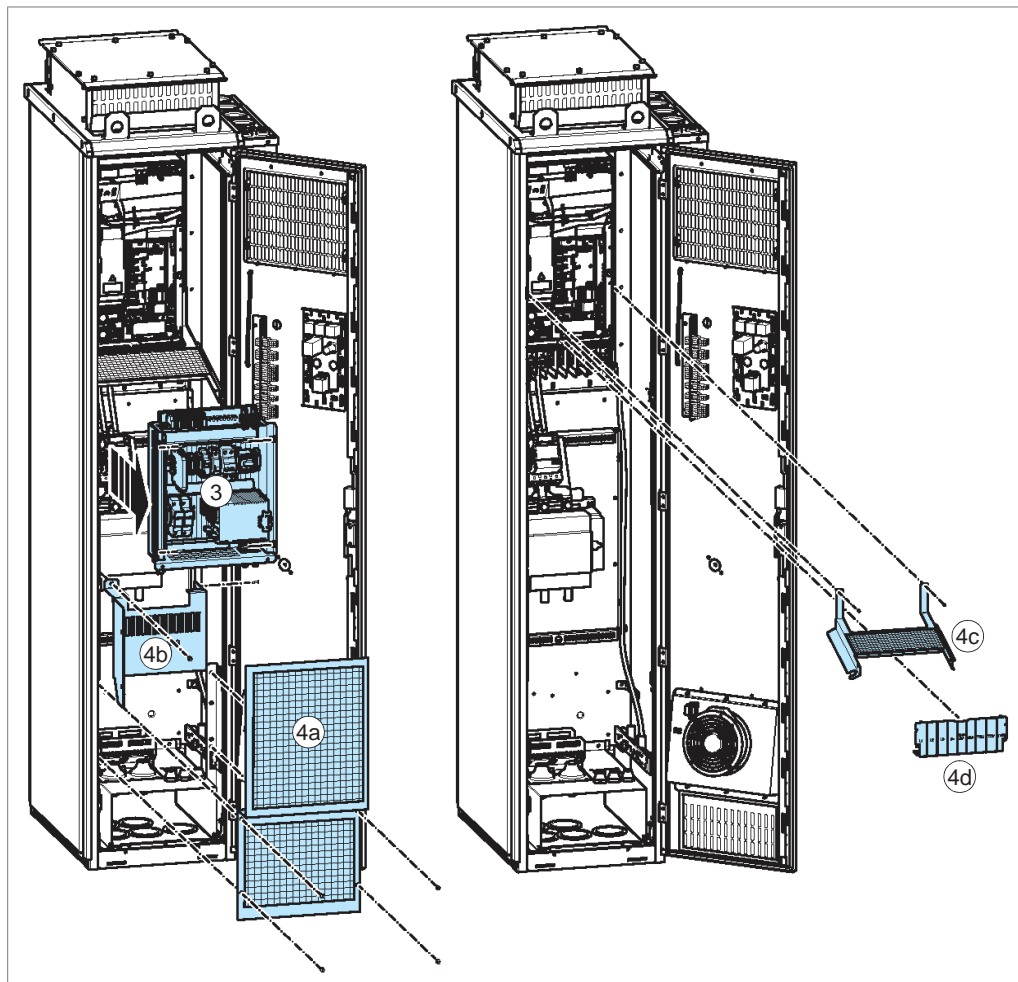

5. For drives without option +E205: Knock out holes in the shroud for the motor cable conductors.
6. Connect the twisted shields of the motor cables to the ground bar and the phase conductors to the U2, V2 and W2 terminals of the drive module. For drives with du/dt filter (option +E205), connect the phase conductors to the T1/U2, T2/V2 and T3/W2 terminals of the cabinet with cable lugs.
7. Connect the twisted shields of the input cables and separate ground cable (if present) to the PE terminal of the cabinet and the phase conductors to the L1, L2 and L3 terminals.

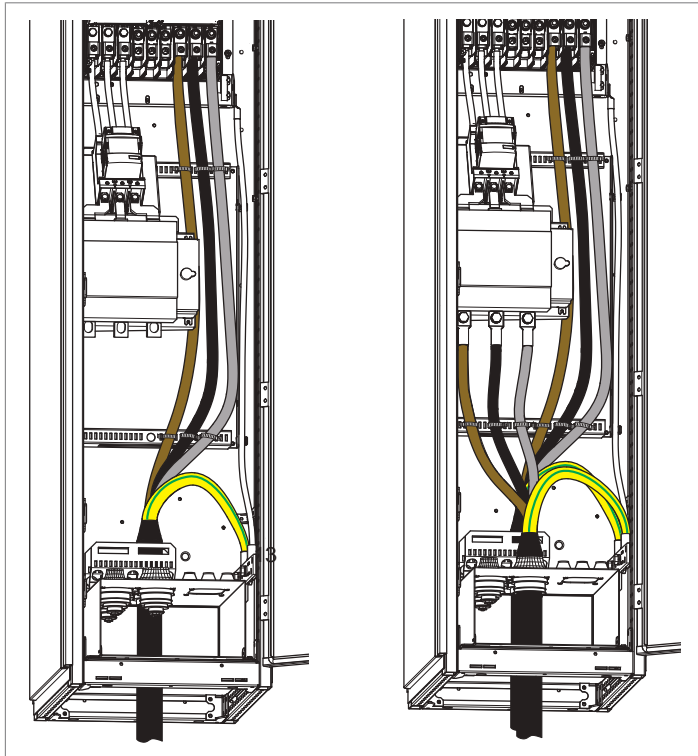

- 
8. Tighten the power cable screws to the torque given in [Terminal and entry data for the power cables \(page 204\)](#).
  9. Reinstall the shrouds and mounting plate.

■ **Connection procedure (frames R6 and R7 with options +H351 and +H353)**

1. Do the steps in section [Electrical safety precautions \(page 18\)](#) before you start the work.
2. Open the cabinet door.
3. Remove the shrouds.

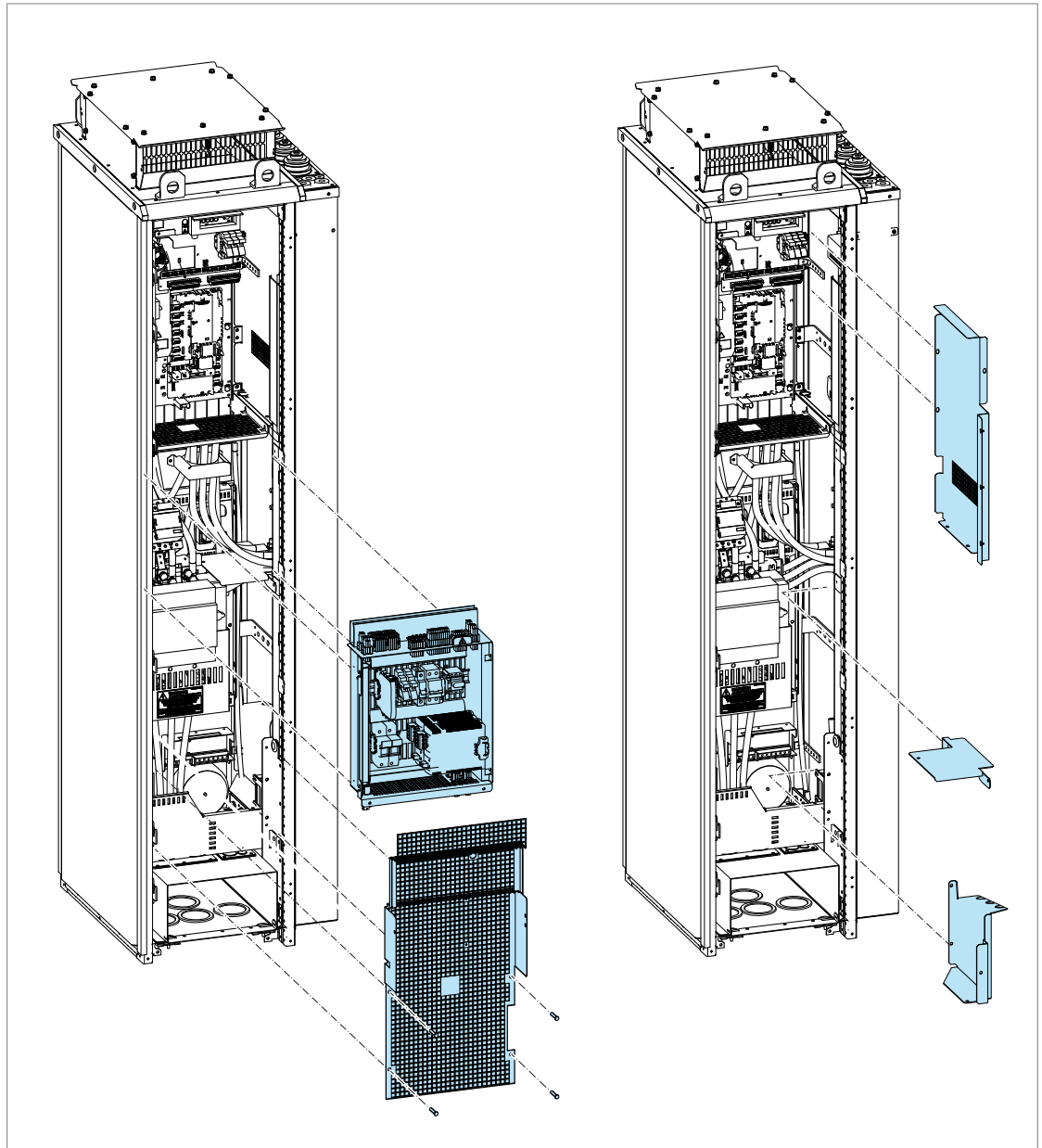

4. Connect the twisted shields of the motor cables to the ground bar and the phase conductors to the U2, V2 and W2 terminals of the drive module.
5. Connect the twisted shields of the input cables and separate ground cable (if present) to the PE terminal of the cabinet and the phase conductors to the L1, L2 and L3 terminals.

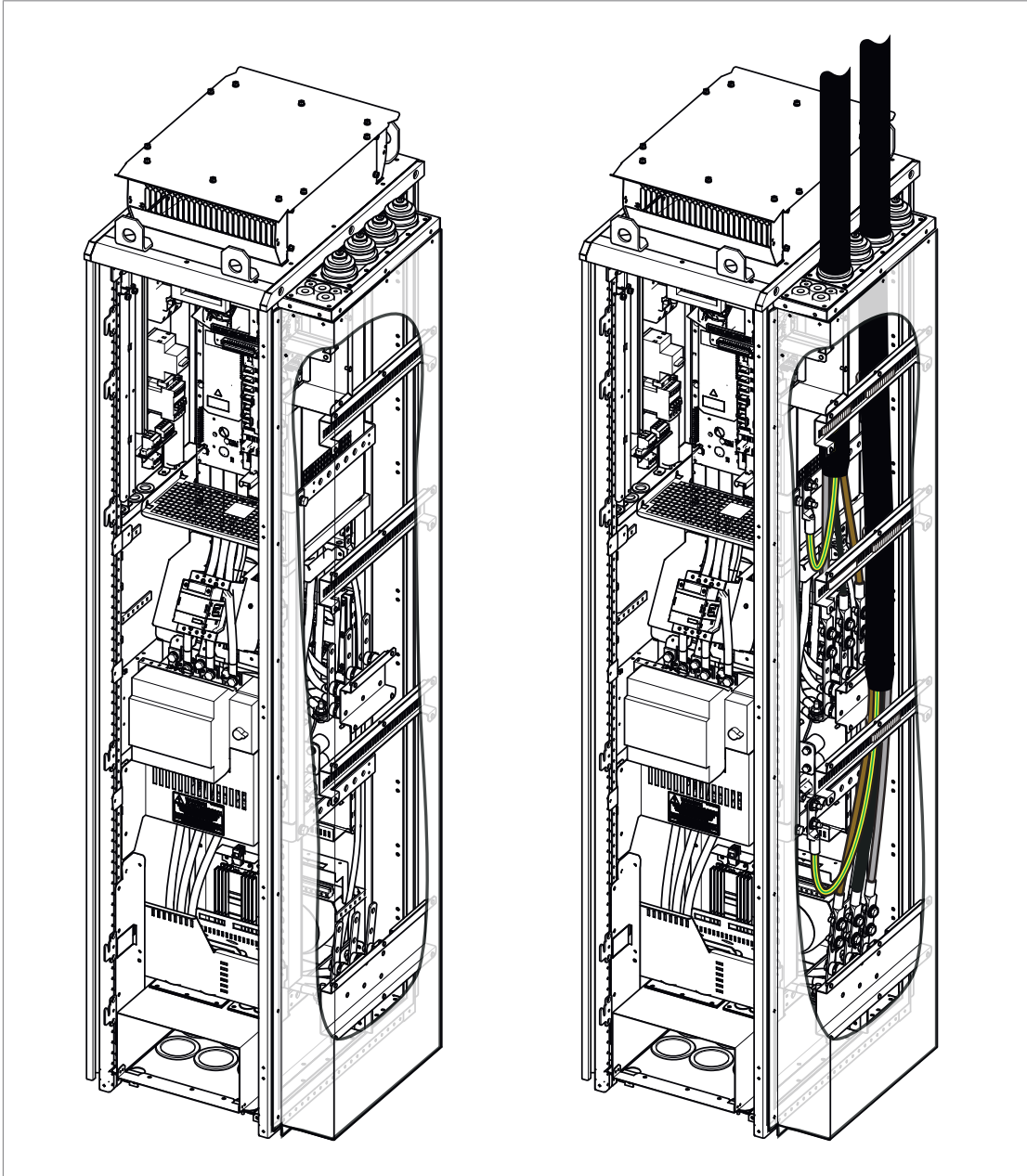

6. Tighten the power cable screws to the torque given in [Terminal and entry data for the power cables \(page 204\)](#).
7. Reinstall the shrouds and mounting plate.

### ■ Connection procedure (frames R8 and R9 with options +H351 and +H353)

1. Do the steps in section [Electrical safety precautions \(page 18\)](#) before you start the work.
2. Open the cabinet door.
3. Remove the shrouds.

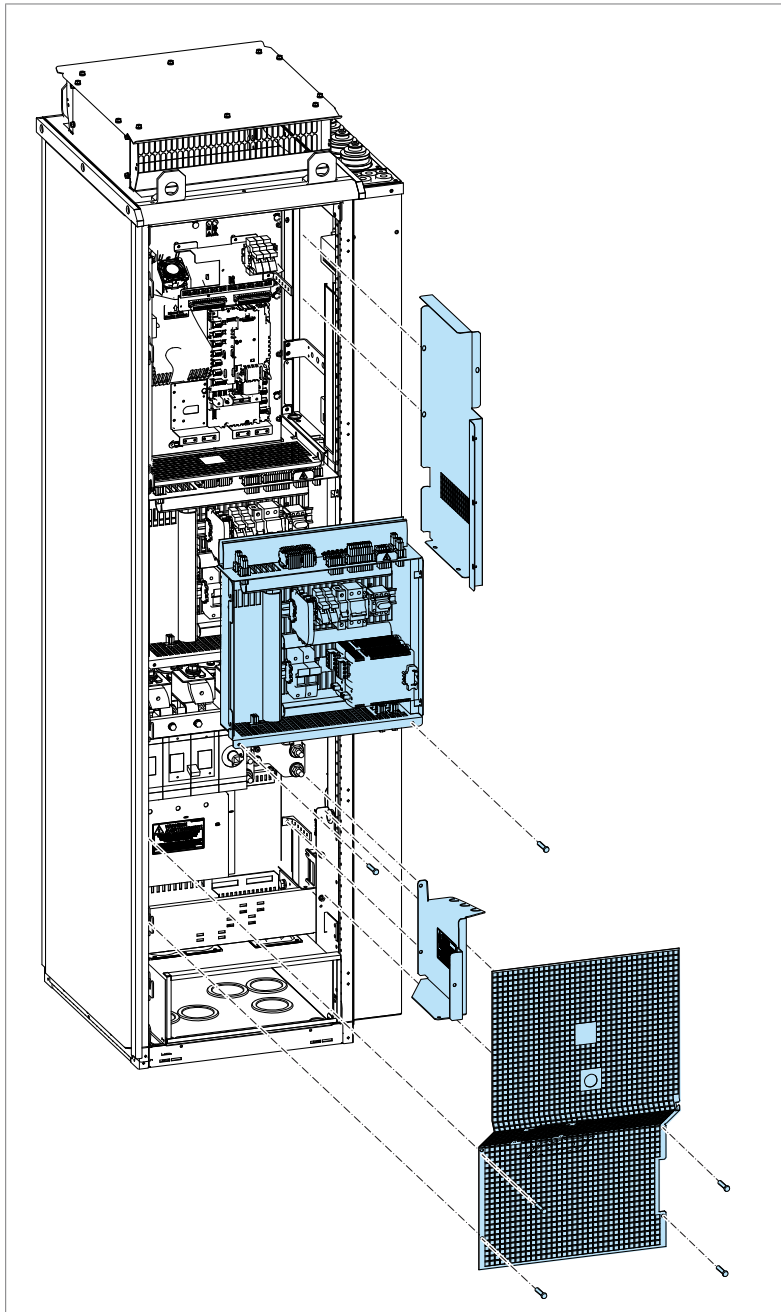

4. Connect the twisted shields of the motor cables to the ground bar and the phase conductors to the U2, V2 and W2 terminals of the drive module.
5. Connect the twisted shields of the input cables and separate ground cable (if present) to the PE terminal of the cabinet and the phase conductors to the L1, L2 and L3 terminals.

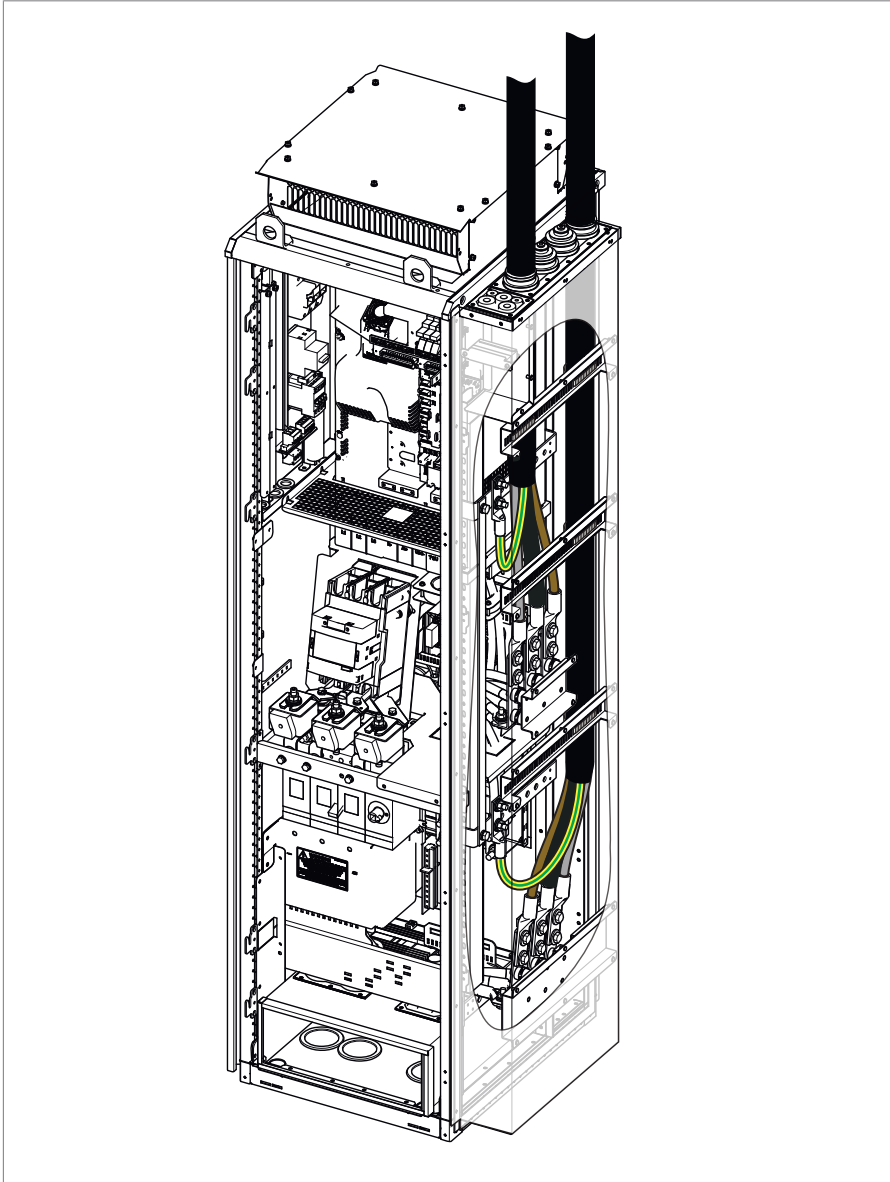

6. Tighten the power cable screws to the torque given in [Terminal and entry data for the power cables \(page 204\)](#).
7. Reinstall the shrouds and mounting plate.



### ■ Connection procedure (frames R10 and R11)

1. Do the steps in section [Electrical safety precautions \(page 18\)](#) before you start the work.
2. Open the cabinet door.
3. Remove the shroud.

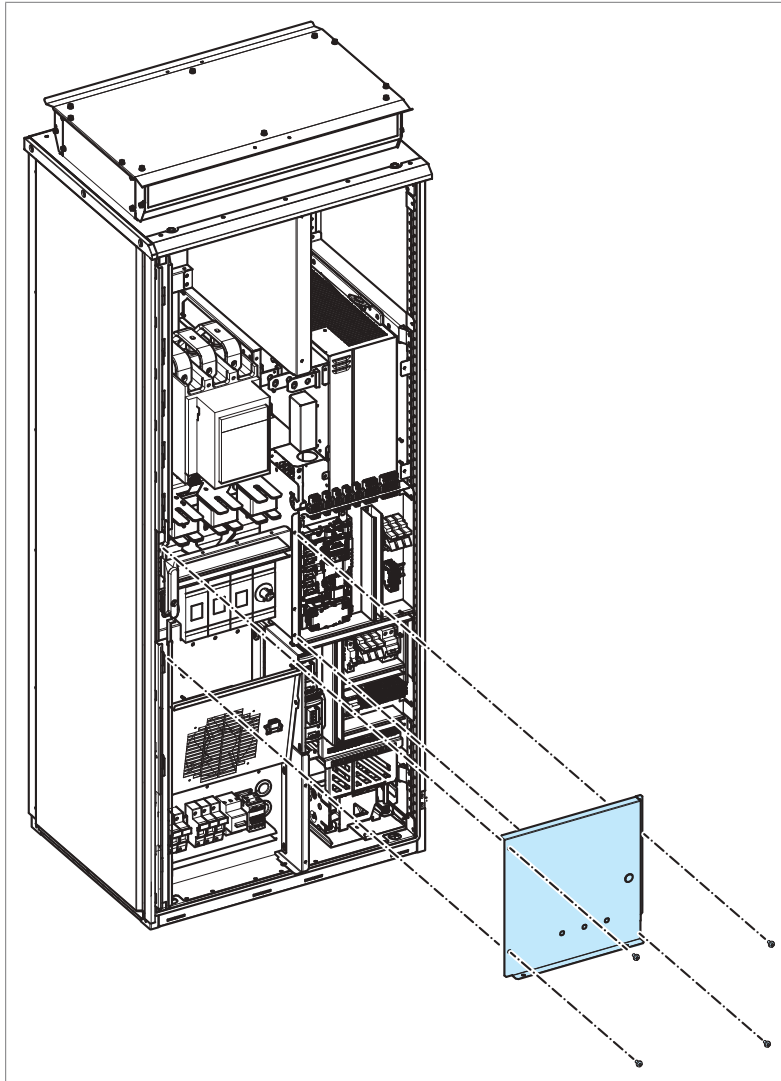

4. Remove the door fan mounting plate. See section [Replacing the door fan \(frames R10 and R11\) \(page 160\)](#)

## 112 Electrical installation

5. Connect the twisted shields of the motor cables to the ground bar and the phase conductors to the U2, V2 and W2 terminals of the drive.
6. Connect the twisted shields of the input cables and separate ground cable (if present) to the PE terminal of the cabinet and the phase conductors to the L1, L2 and L3 terminals.

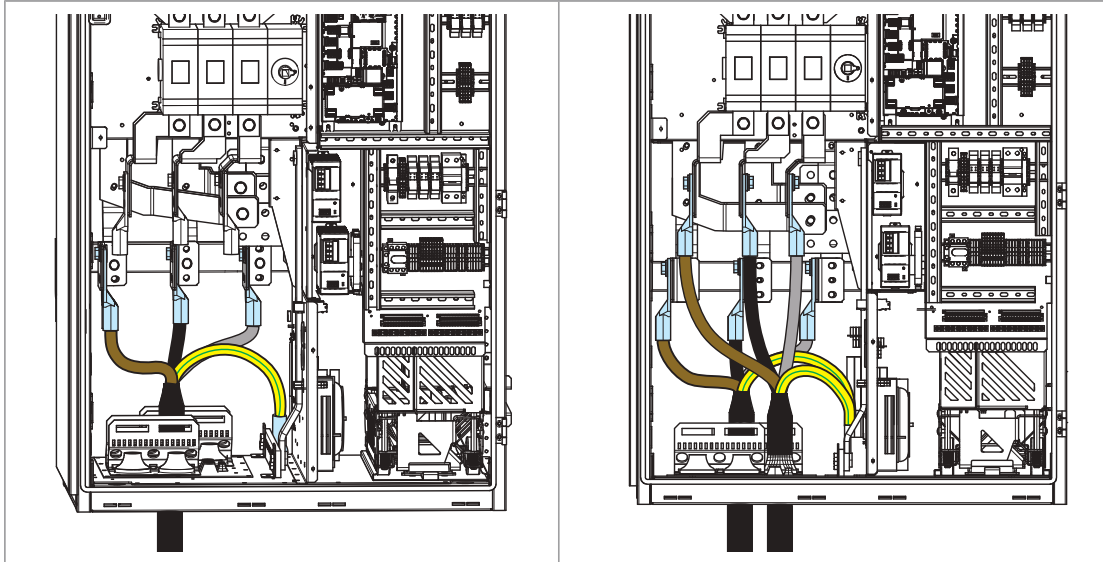

7. Tighten the power cable screws to the torque given in [Terminal and entry data for the power cables](#) (page 204).
8. Reinstall the shrouds and mounting plate.





### ■ Connection procedure (frames R10 and R11 with options +H351 and +H353)

1. Do the steps in section [Electrical safety precautions \(page 18\)](#) before you start the work.
2. Open the cabinet door.
3. With top entry (option +H351) and bottom exit: Undo the mounting screws and pull the shroud out.

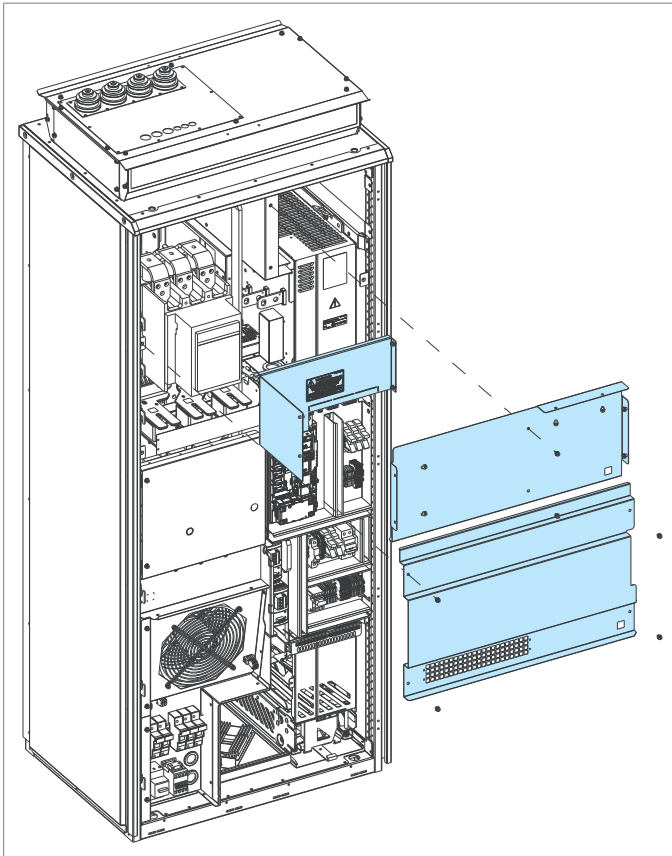

Remove the door fan mounting plate. See section [Replacing the door fan \(frames R10 and R11\) \(page 160\)](#)



4. With top entry and top exit (options +H351 and +H353): Remove the shrouds and door fan (see [Replacing the door fan \(frames R10 and R11\) \(page 160\)](#)). Undo the mounting screws and pull the shrouds out.

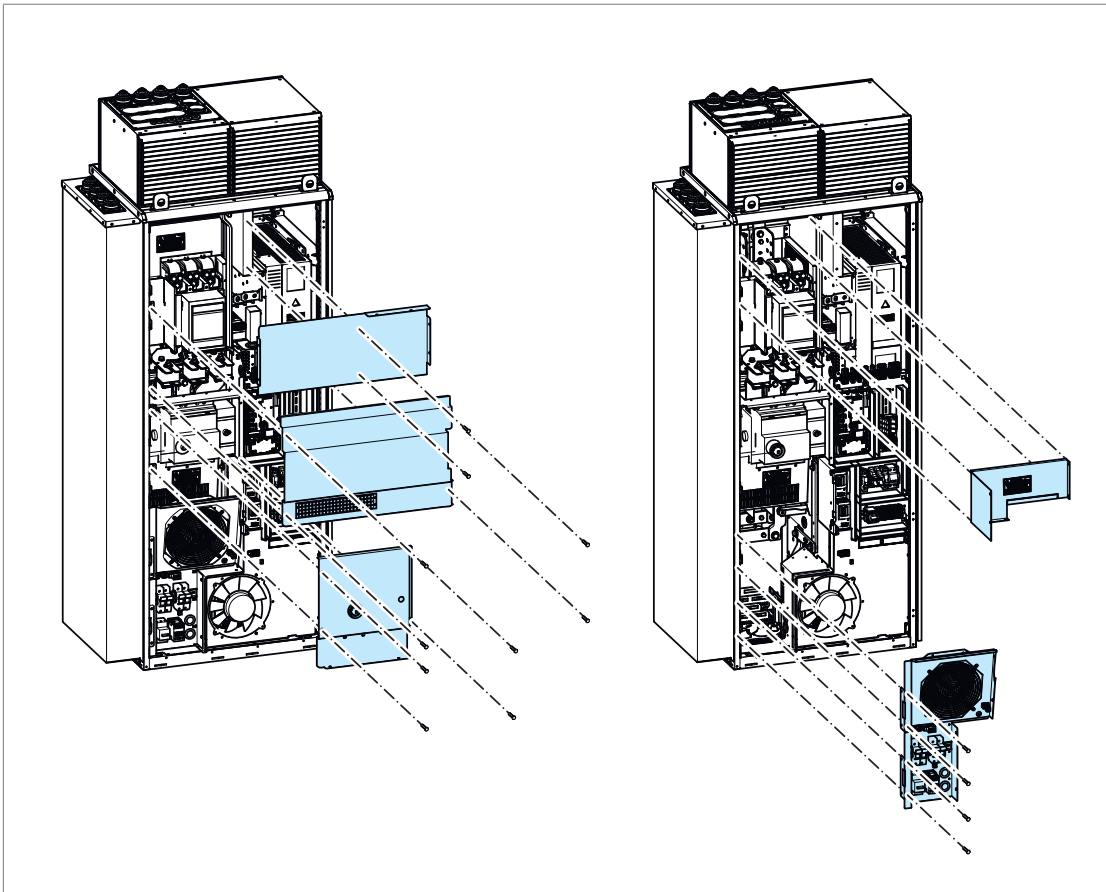

5. Connect the twisted shields of the motor cables to the ground bar and the phase conductors to the U2, V2 and W2 terminals of the drive.
6. Connect the twisted shields of the input cables and separate ground cable (if present) to the PE terminal of the cabinet and the phase conductors to the L1, L2 and L3 terminals.

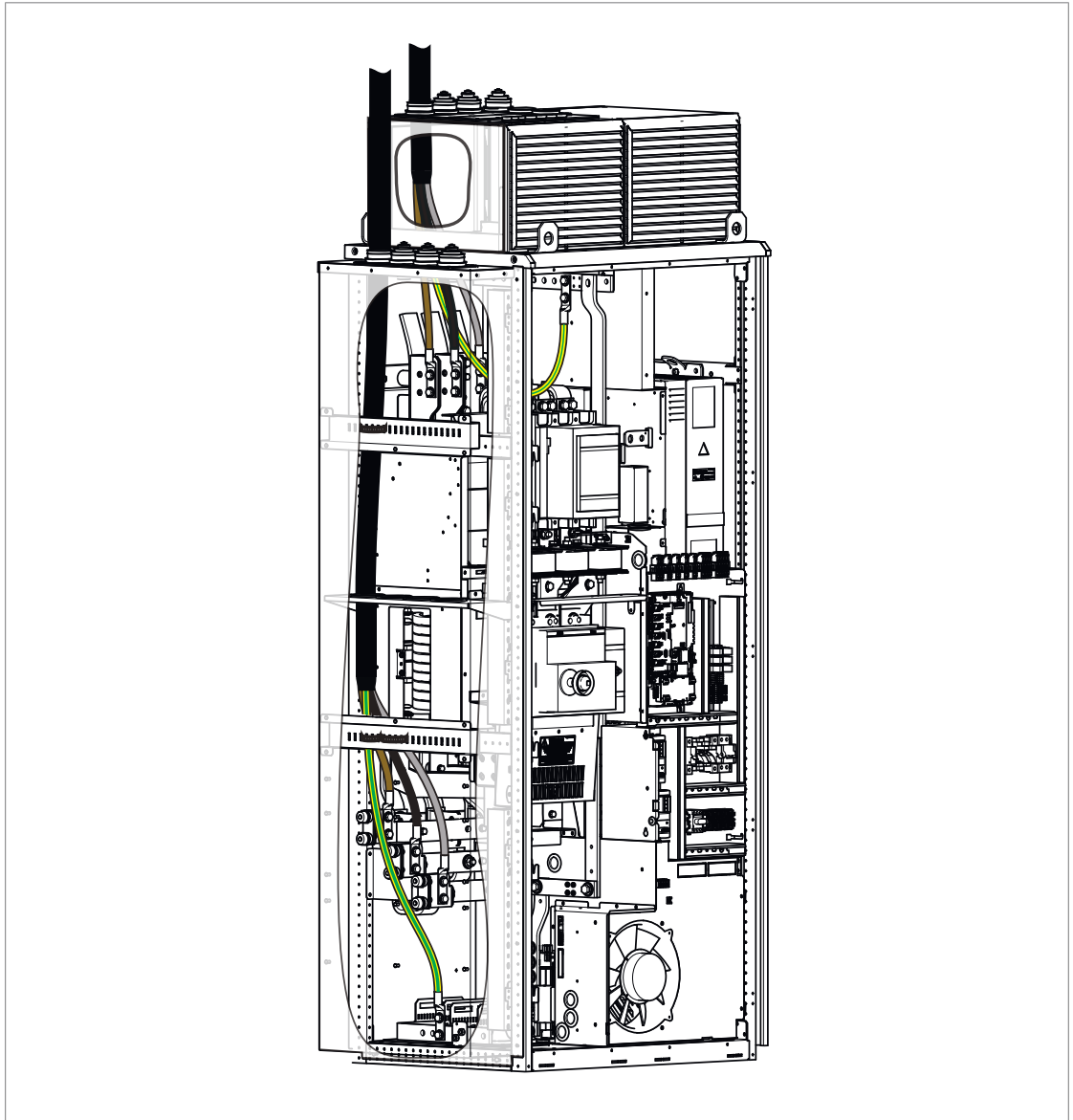

7. Tighten the power cable screws to the torque given in [Terminal and entry data for the power cables \(page 204\)](#).
8. Reinstall the shrouds and mounting plate.

## Connecting the control cables

See chapter [Control unit \(page 131\)](#) for the default I/O connections of the drive control program. The default I/O connections can be different with some hardware options, see the circuit diagrams delivered with the drive for the actual wiring.

Connect the cables as described under [Overview of control cable connection procedure \(page 116\)](#).

## ■ Overview of control cable connection procedure

---



### **WARNING!**

Obey the instructions in chapter [Safety instructions \(page 15\)](#). If you ignore them, injury or death, or damage to the equipment can occur.

---

1. Stop the drive and do the steps in section [Electrical safety precautions \(page 18\)](#) before you start the work.
2. Run the control cables to the inside the cabinet as described in section [Grounding the outer shields of the control cables 360° at the cabinet entry \(page 116\)](#).
3. Route the control cables as described in section [Routing the control cables inside the cabinet \(page 118\)](#).
4. Connect the control cables as described in sections
  - [Connecting external wiring to the control unit or optional I/O terminal block \(page 121\)](#)
  - [Connecting the emergency stop push buttons \(options +Q951 and +Q963\) \(page 123\)](#)
  - [Connecting the Safe torque off circuit \(page 124\)](#)
  - [Connecting external power supply wires for the cabinet heater \(option +G300\) \(page 124\)](#).

## ■ Grounding the outer shields of the control cables 360° at the cabinet entry

Ground the outer shields of all control cables 360° with the EMI conductive cushions at the cabinet entry. The grounding principle is the same for top and bottom entry cables. The figures show the bottom entry. The actual design details can vary.

1. If necessary, temporarily remove the shrouding in front of the cable entry.
2. Put the cables in sequence from the smallest to the largest. This will help to achieve a good contact with the cushions.
3. Loosen the tightening bolts of the EMI conductive cushions and pull them apart.
4. Cut holes in the grommets and put the cables through the grommets.
5. Peel the insulation from the part of the cable that will be in contact with the EMI conductive cushion.
6. Put the cables between the cushions.
7. Move the cushions back together.
8. Tighten the bolts to make sure that the EMI conductive cushions press tightly around the peeled part of the cables.



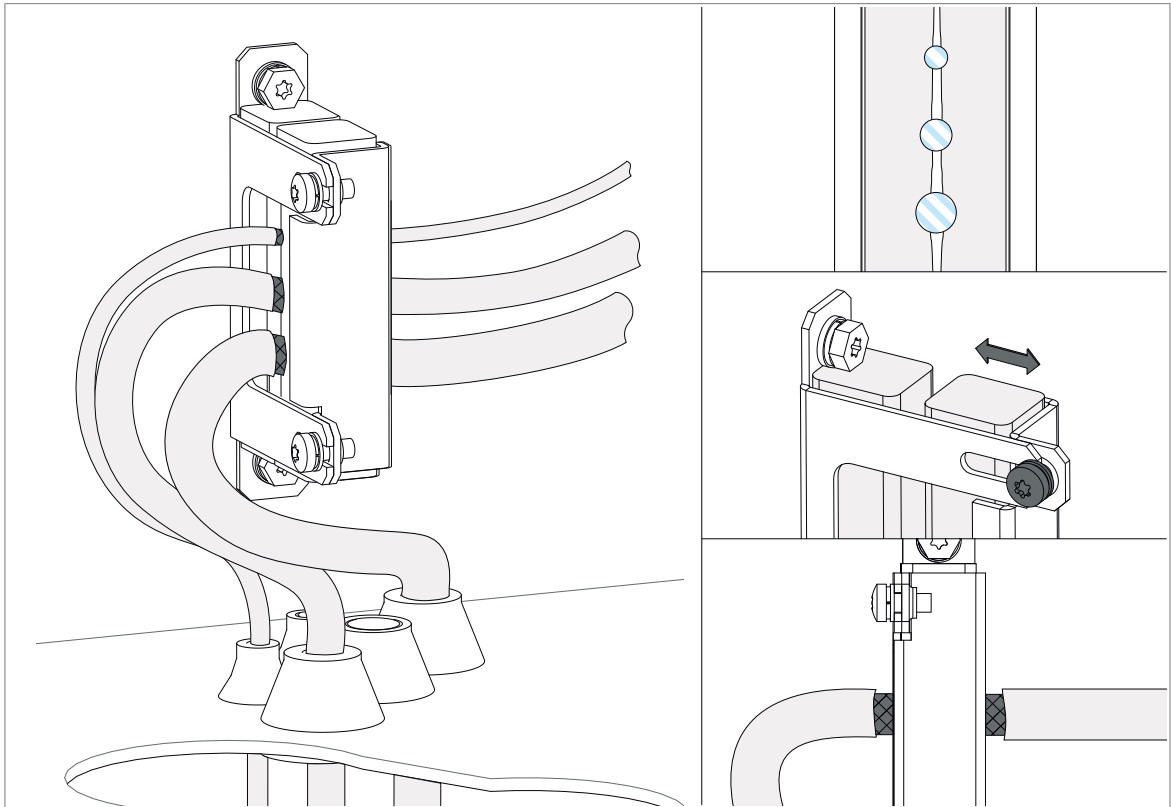

If the outer surface of the shield is non-conductive:

- Cut the shield at the midpoint of the peeled part. Be careful not to cut the conductors or the grounding wire.
- Turn the conductive side of the shield inside out over the insulation.
- Cover the exposed shield and the peeled cable with copper foil to keep the shielding continuous.

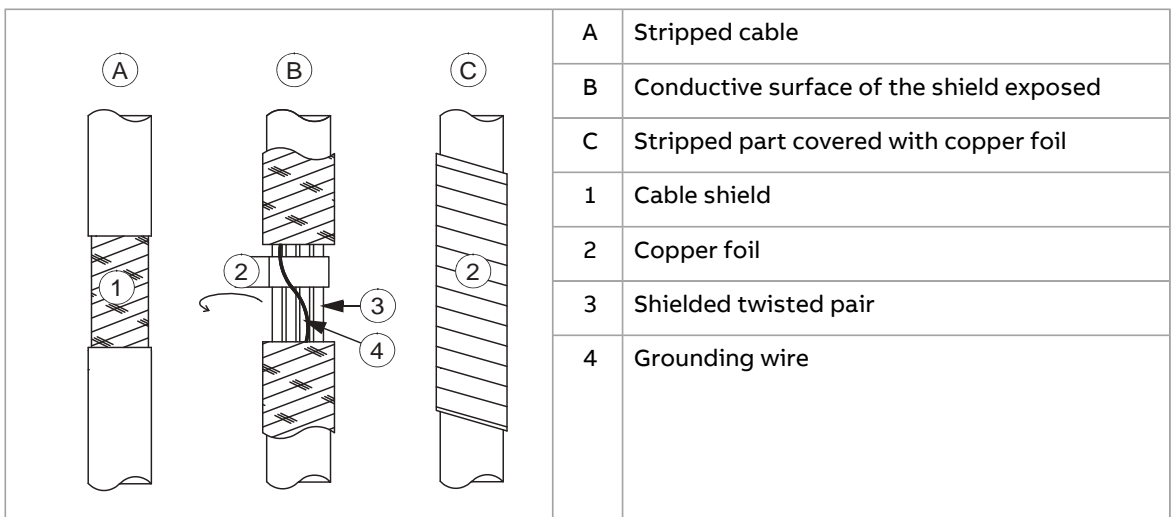

■ **Routing the control cables inside the cabinet**

The route of the control cables is shown below in frame R9. The route is similar for frames R6, R7 and R8.

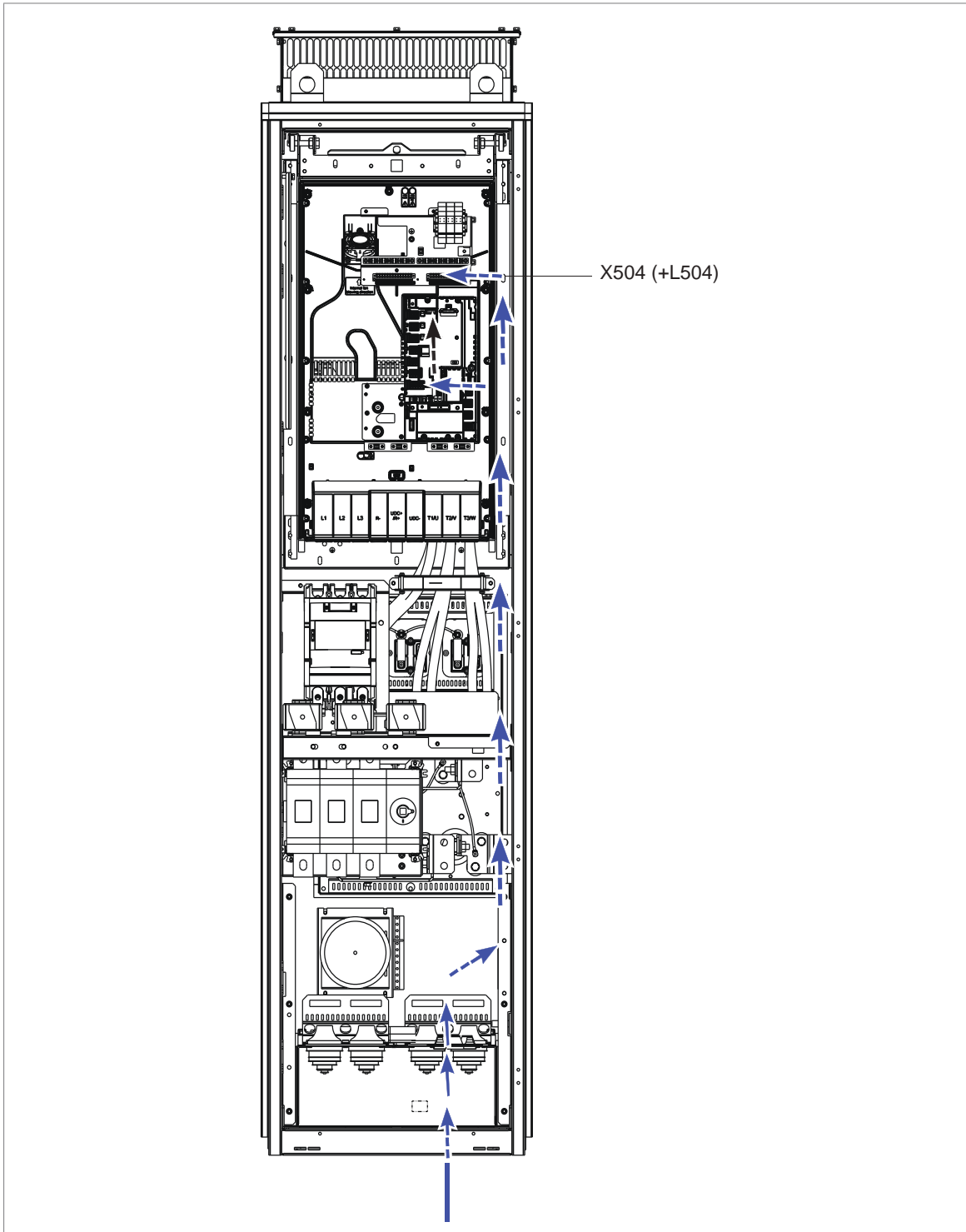

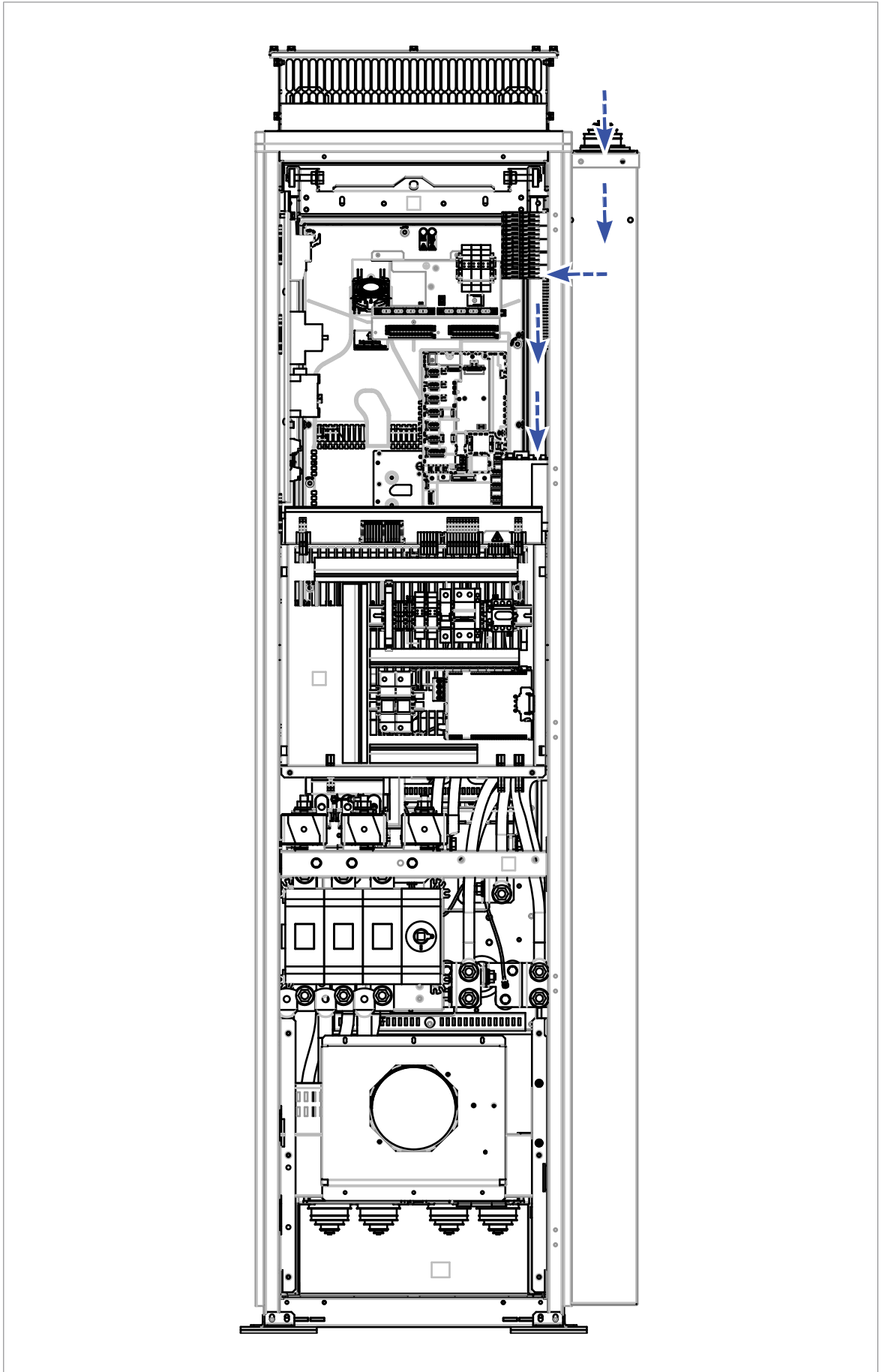

The route of the control cables for frames R10 and R11 is shown below.

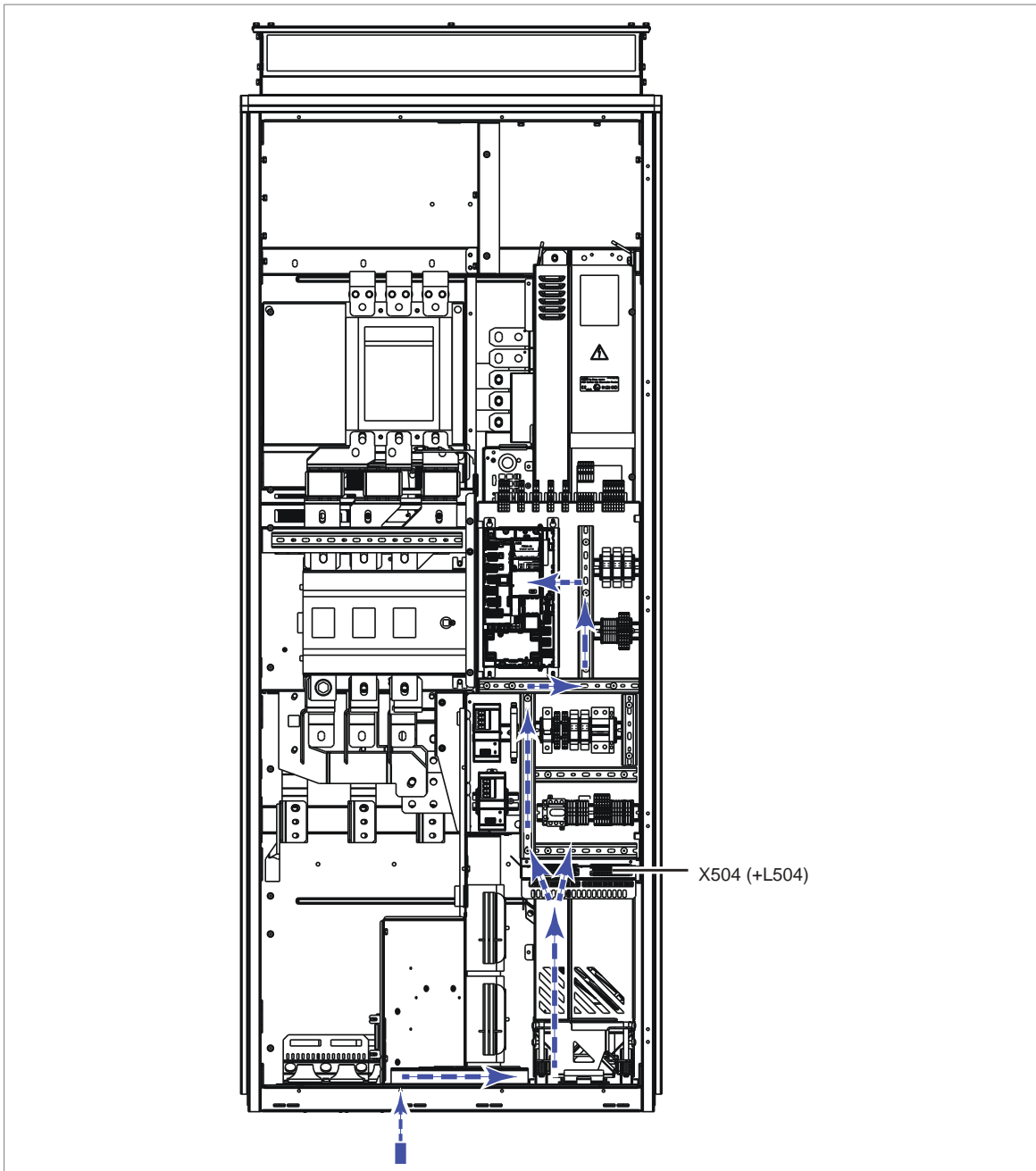



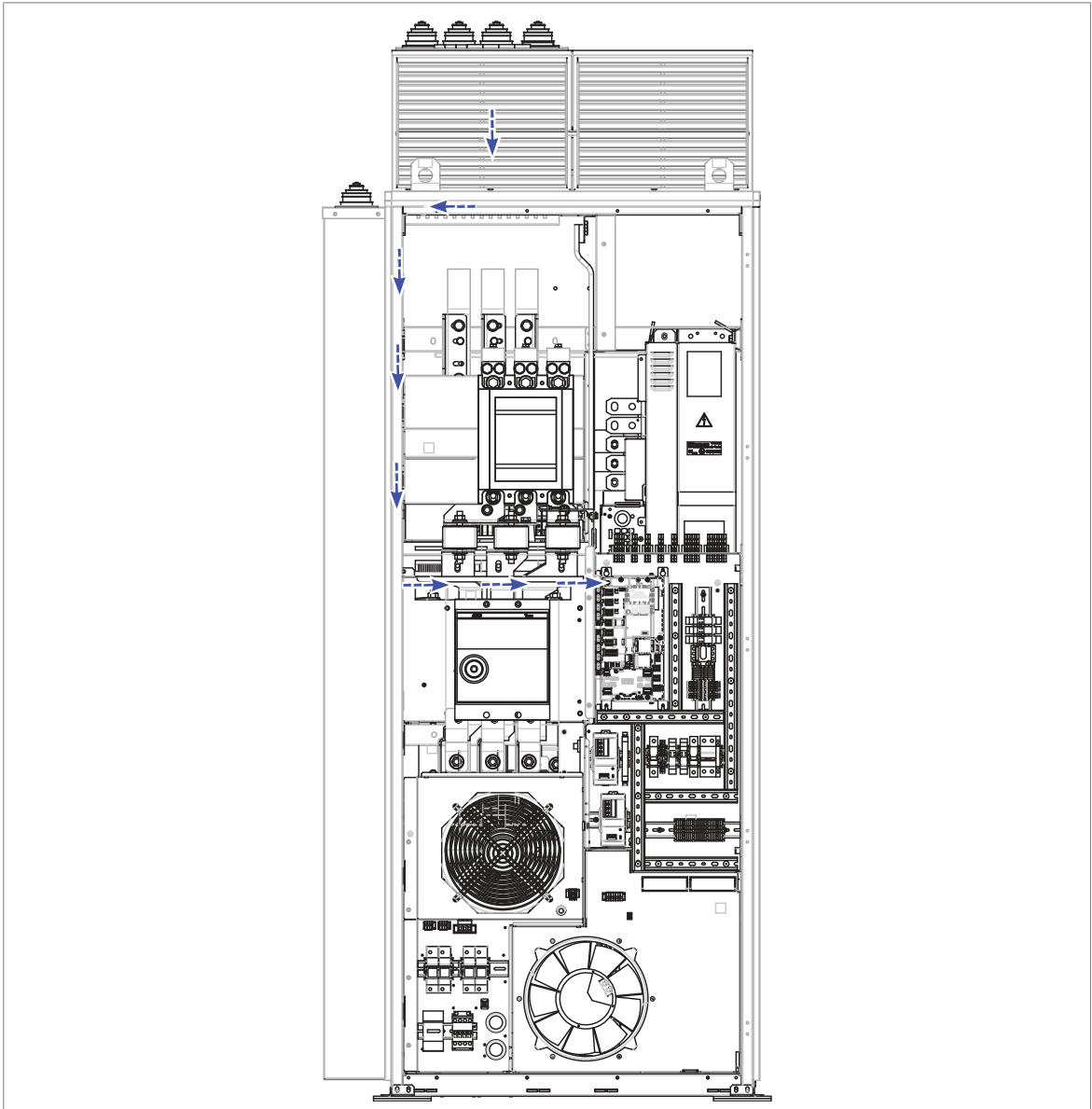

### ■ Connecting external wiring to the control unit or optional I/O terminal block

**Note:** Keep any signal wire pairs twisted as close to the terminals as possible. Twisting the wire with its return wire reduces disturbances caused by inductive coupling.

**Note:** Leave slack to the control wires to make it possible to lift the control unit mounting plate a little when the drive module is replaced.

Ground the pair-cable shields and all grounding wires to the grounding clamp.

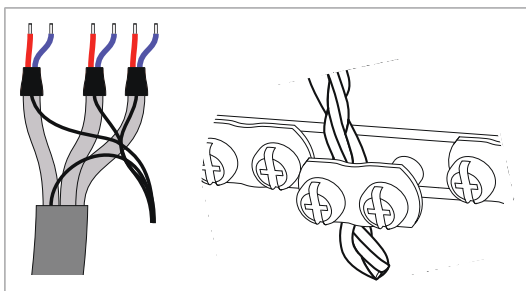

Leave the other ends of the control cable shields unconnected or ground them indirectly via a high-frequency capacitor with a few nanofarads, eg, 3.3 nF / 630 V. The shield can also be grounded directly at both ends if they are in the same ground line with no significant voltage drop between the end points.

Connect the conductors to the appropriate terminals (see [Control unit \(page 131\)](#)) of the control unit or with option +L504 to the detachable terminal block X504.

### ■ Connecting for wired remote monitoring (option +K496)

This option provides a gateway to connect the drive to ABB Ability™ via a local Ethernet network. Includes NETA-21 remote monitoring tool and FMBT-21 Modbus/TCP adapter module.

The NETA and FMBT-21 are installed at the factory and wired internally. An Ethernet cable for customer connection is routed from the NETA to the external control connections mounting plate. Use an RJ45 coupler (not included) to connect your Ethernet cable to the additional Ethernet cable.

See the appropriate manual for more information.

| Manual  | Code (English)                  |
|---|---------------------------------|
| NETA-21 remote monitoring tool user's manual                            | <a href="#">3AUA0000096939</a>  |
| NETA-21 remote monitoring tool installation and start-up guide          | <a href="#">3AUA0000096881</a>  |
| FMBT-21 Modbus/TCP adapter module user's manual                         | <a href="#">3AXD50000158607</a> |
| FMBT-21 Modbus/TCP adapter module quick installation and start-up guide | <a href="#">3AXD50000158560</a> |

### ■ Connecting for wireless remote monitoring (option +K497)

This option provides a gateway to connect the drive to ABB Ability™ via a wireless 4G network. Includes NETA-21 remote monitoring tool, FMBT-21 Modbus/TCP adapter module and modem.

The NETA and FMBT-21 are installed at the factory and wired internally. An Ethernet cable for customer connection is routed from the NETA to the external control connections mounting plate. Use an RJ45 coupler (not included) to connect your Ethernet cable to the additional Ethernet cable.

See the appropriate manual for more information.

| Manual  | Code (English)                  |
|---|---------------------------------|
| NETA-21 remote monitoring tool user's manual                            | <a href="#">3AUA0000096939</a>  |
| NETA-21 remote monitoring tool installation and start-up guide          | <a href="#">3AUA0000096881</a>  |
| FMBT-21 Modbus/TCP adapter module user's manual                         | <a href="#">3AXD50000158607</a> |
| FMBT-21 Modbus/TCP adapter module quick installation and start-up guide | <a href="#">3AXD50000158560</a> |



■ **Connecting a 230/115 V AC auxiliary voltage supply (UPS, option +G307)**

Wire the external control voltage to terminal block X307 as shown below.

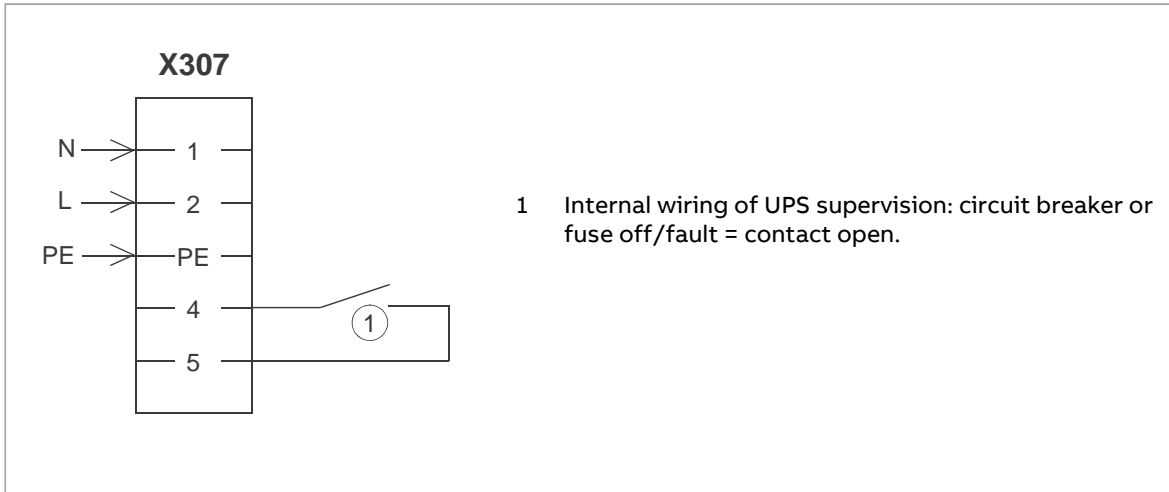

■ **Connecting the emergency stop push buttons (options +Q951 and +Q963)**

See the circuit diagrams delivered with the drive for connecting the emergency stop circuit and the user manuals of the options.

**Frames R6...R9**

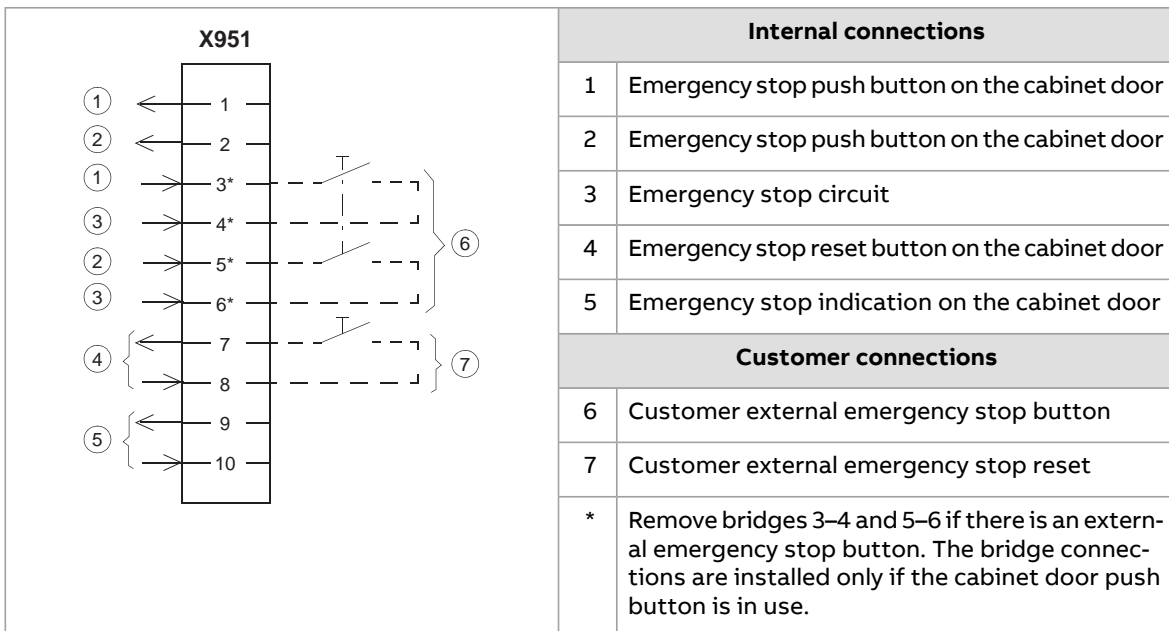

**Frames R10 and R11**

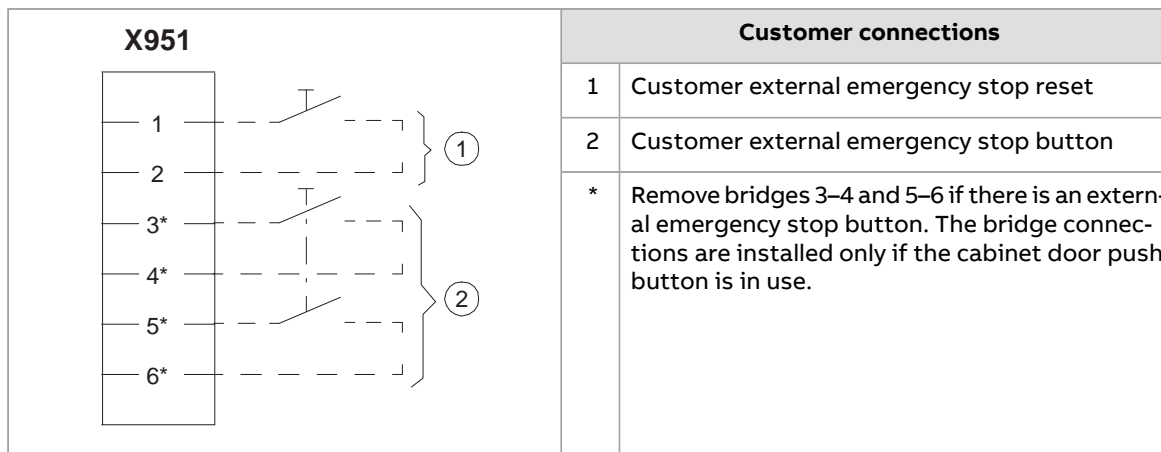

■ **Wiring the starter for auxiliary motor fan (options +M601...M605)**

Connect the power supply wires for the auxiliary motor fan to terminal block X601 according to the circuit diagrams delivered with the drive.

■ **Connecting the Safe torque off circuit**

Connect the customer Safe torque off circuit as described in chapter [The Safe torque off function \(page 269\)](#).

For drives with options +Q951 and +Q963, connect the Safe torque off circuit to terminal block X969 – not to the control unit STO terminals.:

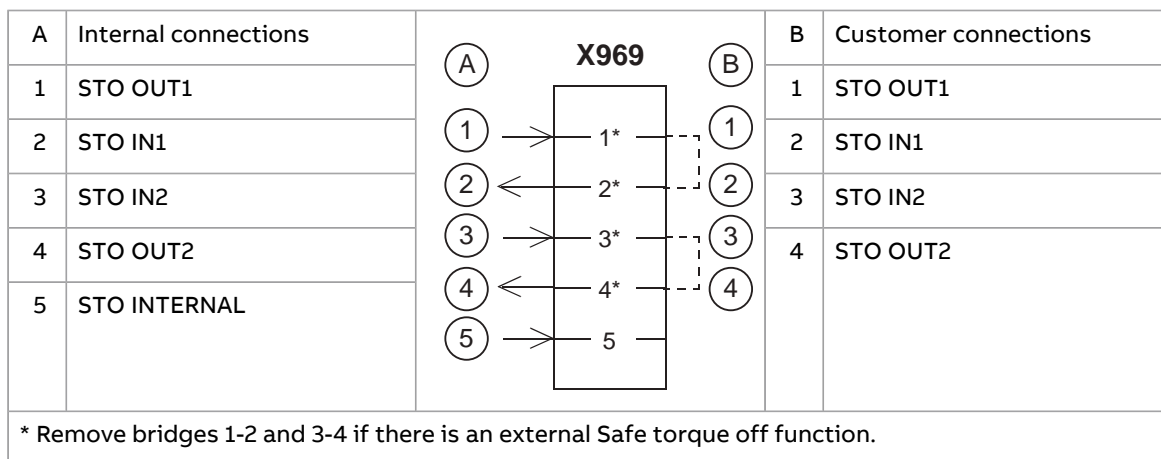

■ **Connecting external power supply wires for the cabinet heater (option +G300)**

See the circuit diagrams delivered with drive.

Connect the external power supply wires for the cabinet heater to terminal block X300 at the back of the mounting plate.

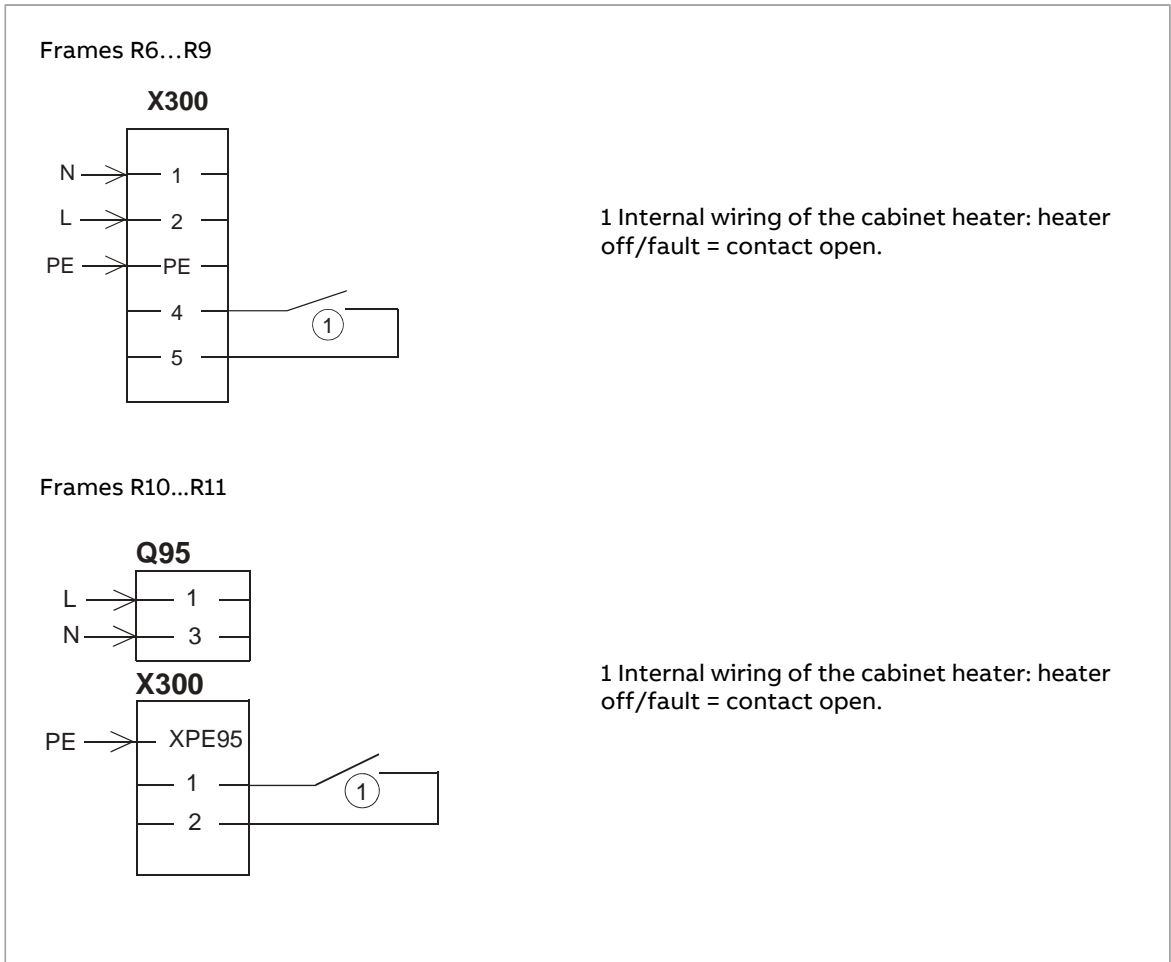

■ **Connecting external power supply wires for the motor space heater (option +G313)**

See the circuit diagrams delivered with drive.

Connect the motor heater wiring to terminal block X313 as shown below. Maximum external power supply 16 A.

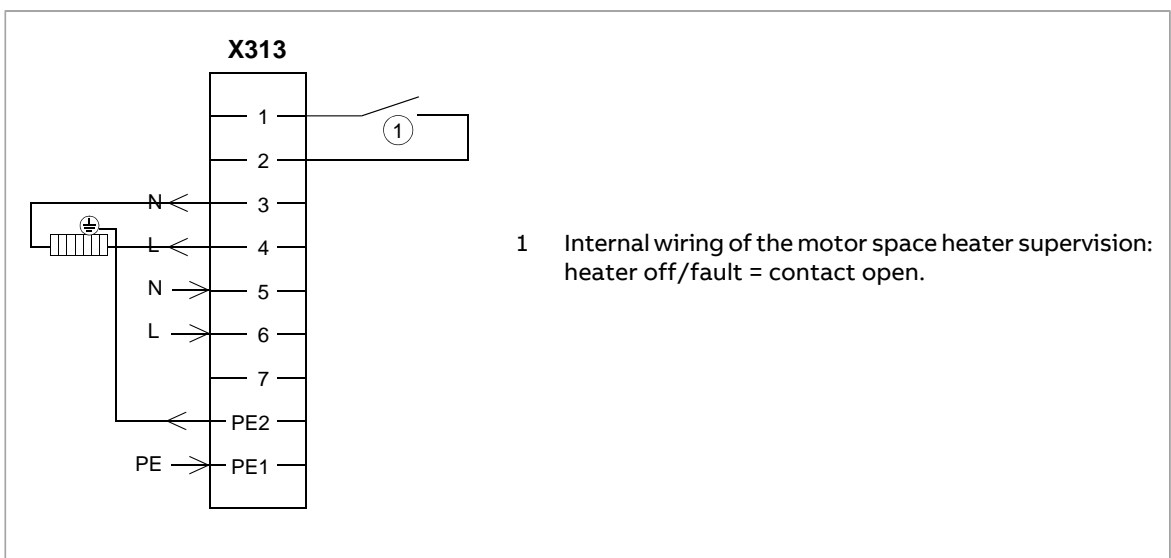

■ **Wiring the Pt100 relays (option +nL506)**

External wiring of sensor modules is shown below. Contact load capacity 250 V AC 10 A. For the actual wiring, see the circuit diagram delivered with the drive.

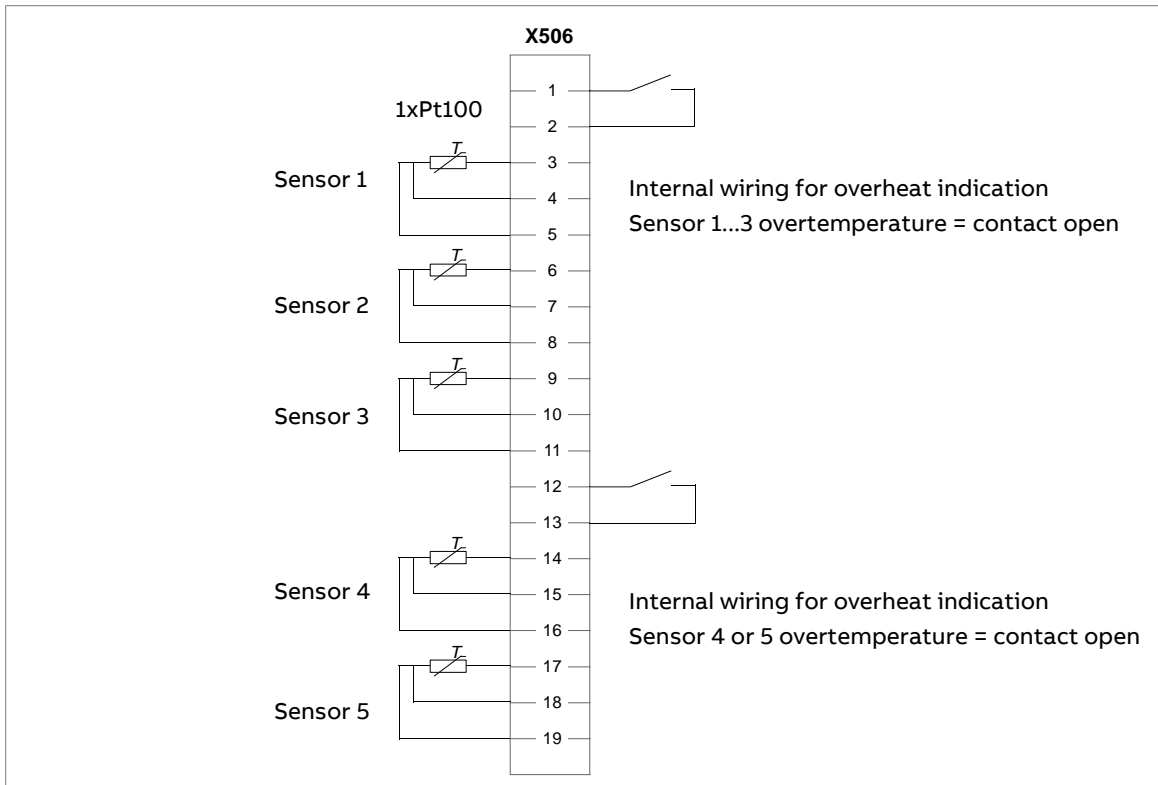

**Setting the voltage range of the auxiliary control voltage transformer (T21)**

Connect the power supply wires of the auxiliary control voltage transformer according to the power network voltage.

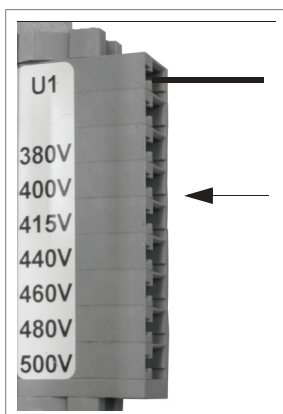

## Connecting a PC

**WARNING!**

Do not connect the PC directly to the control panel connector of the control unit. It can cause damage.

A PC (with, for example, the Drive Composer PC tool) can be connected as follows:

1. To connect a control panel to the unit, either
  - insert the control panel into the panel holder or platform, or
  - use an Ethernet (eg, Cat 5e) networking cable.
2. Remove the USB connector cover on the front of the control panel.
3. Connect an USB cable (Type A to Type Mini-B) between the USB connector on the control panel (3a) and a free USB port on the PC (3b).
4. The panel will display an indication whenever the connection is active.
5. See the documentation of the PC tool for setup instructions.

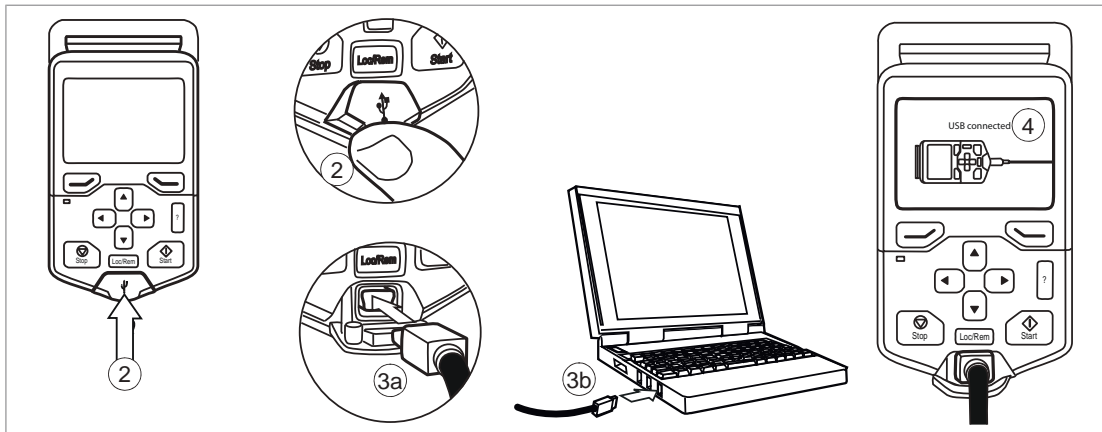

## Installing option modules

### ■ Option slot 1 (fieldbus adapter modules)



**WARNING!**

Obey the safety instructions of the drive. If you ignore them, injury or death, or damage to the equipment can occur. If you are not a qualified electrical professional, do not do installation, commissioning or maintenance work.



**WARNING!**

Use ESD wristband when you handle printed circuit boards. Do not touch the boards unnecessarily. The boards are sensitive to electrostatic discharge.

Pay attention to the free space required by the cabling or terminals coming to the option modules.

1. Stop the drive and do the steps in section [Electrical safety precautions \(page 18\)](#) before you start the work.
2. Pull out the lock (a) with a screw driver.

**Note:** The location of the lock depends on the module type.

3. Install the module to a free option module slot on the control unit.
4. Push in the lock (a).
5. Tighten the grounding screw (b) to a torque of 0.8 N·m (7 lbf·in).

**Note:** The screw tightens the connections and grounds the module. It is essential for fulfilling the EMC requirements and for proper operation of the module.



**WARNING!**

Do not use excessive force, or leave the screw too loose. Over-tightening can cause damage to the screw or module. A loose screw can cause an operation failure.

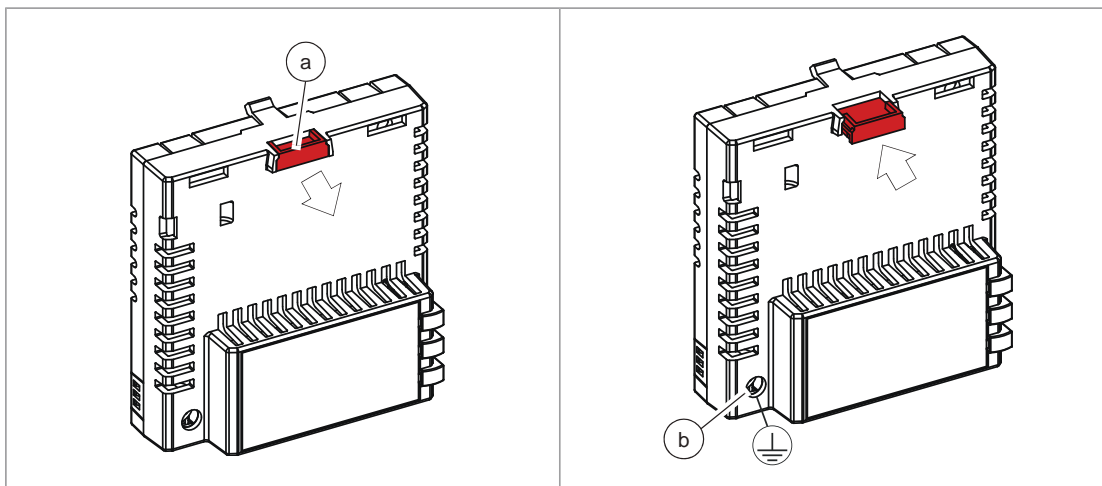

6. Connect the wiring to the module. Obey the instructions given in the documentation of the module.



If you must remove the option module after it is installed into the drive, use a suitable tool (for example, small pliers) to carefully pull out the lock.

### ■ Option slot 2 (I/O extension modules)



#### **WARNING!**

Obey the safety instructions of the drive. If you ignore them, injury or death, or damage to the equipment can occur. If you are not a qualified electrical professional, do not do installation, commissioning or maintenance work.



#### **WARNING!**

Use ESD wristband when you handle printed circuit boards. Do not touch the boards unnecessarily. The boards are sensitive to electrostatic discharge.

1. Put the module carefully into its position on the control unit.
2. Tighten the mounting screw.
3. Tighten the grounding screw (CHASSIS) to 0.8 N·m (7 lbf·in). The screw grounds the module. This is necessary for fulfilling the EMC requirements and for correct operation of the module.

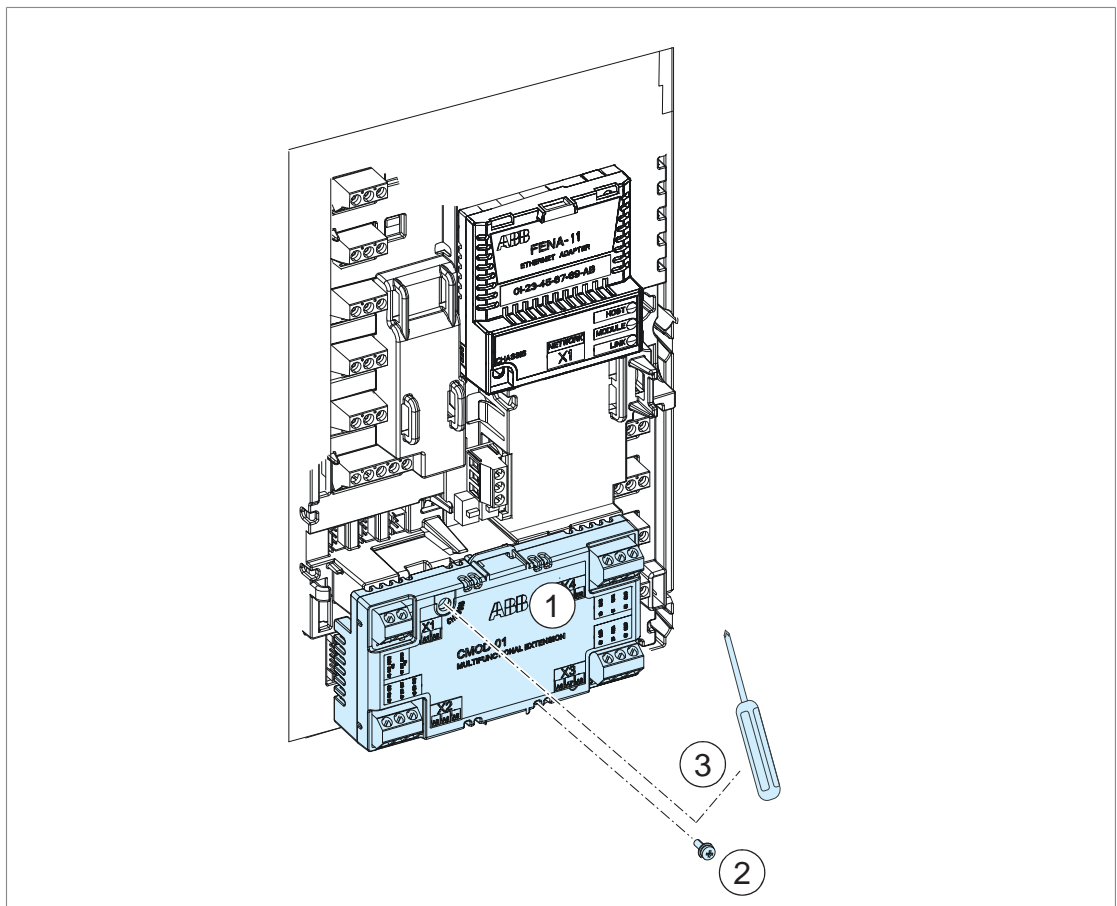

### ■ Wiring the optional modules

See the appropriate option module manual or for I/O options the appropriate chapter in this manual.



A large, light gray square with rounded corners, centered on the page. Inside the square is a large, bold, black number '7'.

## Control unit

---

### Contents of this chapter

This chapter contains the default I/O connection diagram, descriptions of the terminals and technical data for the drive control unit CCU-24.

---

## Layout CCU-24

The layout of the external control connection terminals on the drive module control unit is shown below.

| SLOT 1                                   |  |
|--|--|
| Option slot 1 (fieldbus adapter modules) |  |
| ANALOG IN/OUT                            |  |
| 1...3                                    | Analog input 1   |
| 4...6                                    | Analog input 2   |
| 7...9                                    | Analog outputs   |
| 10...12                                  | Auxiliary voltage output, digital input common                                   |
| DIGITAL IN                               |  |
| 13...18                                  | Digital inputs   |
| STO                                      |  |
| 34...38                                  | Safe torque off connection.  |
| AIR IN TEMP                              | Internal air temperature NTC sensor connection                                   |
| FAN2                                     | Internal fan 2 connection  |
| FAN1                                     | Internal fan 1 connection  |
| X12                                      | Panel port (control panel connection, wired at the factory to the control panel) |
| X15                                      | Reserved to internal use.  |
| EFB                                      |  |
| EIA/RS-485 fieldbus connector            |  |
| BIAS                                     | Bias resistor switch   |
| TERM                                     | End termination switch   |
| 29...31                                  | Connection terminals   |
| SLOT 2                                   |  |
| Option slot 2 (I/O extension modules)    |  |
| EXTERNAL POWER IN                        |  |
| 40, 41                                   | 24 V AC/DC external power input  |
| RO1 ... RO3                              |  |
| 19...21                                  | Relay output 1 (RO1)   |
| 22...24                                  | Relay output 2 (RO2)   |
| 25...27                                  | Relay output 3 (RO3)   |

STO is reserved for internal use with options +Q951 and +Q963.

## Default I/O connections for HVAC default

| Connection   | Term | Description |  |
|--|------|-------------|--|
| <b>X1 Reference voltage and analog inputs and outputs</b>              |      |             |  |
|  | 1    | SCR         | Signal cable shield (screen)               |
|  | 2    | AI1         | Output frequency/speed reference: 0...10 V |
|  | 3    | AGND        | Analog input circuit common                |
|  | 4    | +10V        | Reference voltage 10 V DC                  |
|  | 5    | AI2         | Actual feedback: 0...22 mA                 |
|  | 6    | AGND        | Analog input circuit common                |
|  | 7    | AO1         | Output frequency: 0...10 V                 |
|  | 8    | AO2         | Motor current: 0...20 mA                   |
|  | 9    | AGND        | Analog output circuit common               |
| <b>X2 &amp; X3 Aux. voltage output and programmable digital inputs</b> |      |             |  |
|  | 10   | +24V        | Aux. voltage output +24 V DC, max. 250 mA  |
|  | 11   | DGND        | Aux. voltage output common                 |
|  | 12   | DCOM        | Digital input common for all               |
|  | 13   | DI1         | Stop (0) / Start (1)                       |
|  | 14   | DI2         | Not configured                             |
|  | 15   | DI3         | Constant frequency/speed selection         |
|  | 16   | DI4         | Start interlock 1 (1 = allow start)        |
|  | 17   | DI5         | Not configured                             |
|  | 18   | DI6         | Not configured                             |
| <b>X6, X7, X8 Relay outputs</b>  |      |             |  |
|  | 19   | RO1C        | Damper control                             |
|  | 20   | RO1A        | 250 V AC / 30 V DC                         |
|  | 21   | RO1B        | 2 A  |
|  | 22   | RO2C        | Running                                    |
|  | 23   | RO2A        | 250 V AC / 30 V DC                         |
|  | 24   | RO2B        | 2 A  |
|  | 25   | RO3C        | Fault (-1)                                 |
|  | 26   | RO3A        | 250 V AC / 30 V DC                         |
|  | 27   | RO3B        | 2 A  |
| <b>X5 Modbus RTU</b>   |      |             |  |
|  | 29   | B+          | Embedded Modbus RTU (EIA-485)              |
|  | 30   | A-          |  |
|  | 31   | DGND        |  |
|  | S4   | TERM        | Serial data link termination switch        |
|  | S5   | BIAS        | Serial data link bias resistors switch     |
| <b>X4 Safe torque off</b>  |      |             |  |

## 134 Control unit

| Connection  | Term | Description    |
|---|------|----------------|
|   | 34   | OUT1           |
|   | 35   | OUT2           |
|   | 36   | SGND           |
|   | 37   | IN1            |
|   | 38   | IN2            |
| <b>X10 24 V AC/DC (CCU-24 only)</b>   |      |                |
|   | 40   | 24 V AC/DC+ in |
|   | 41   | 24 V AC/DC- in |
| Safe torque off. Factory connection. Both circuits must be closed for the drive to start.<br>Refer to <a href="#">The Safe torque off function (page 269)</a> |      |                |
| External 24 V AC/DC input to power up the control unit when the main supply is disconnected.  |      |                |

Refer to section [CCU-24 technical data \(page 140\)](#) for total load capacity of auxiliary voltage output and other specifications, terminal sizes, tightening torques and wire strip length.

| Instructions and additional info to the I/O diagram  |     |                            |                        |
|--|-----|----------------------------|------------------------|
| Analog inputs and outputs  |     |                            |                        |
| Ground the outer shield of the cables 360° at the cabinet entry.   |     |                            |                        |
| AI1:   |     |                            |                        |
| <ul style="list-style-type: none"> <li>Current [0(4)...20 mA, <math>R_{in} = 100 \text{ ohm}</math>] or voltage [0(2)...10 V, <math>R_{in}</math> , changed by the corresponding parameter.</li> <li>Used as a speed reference if vector control is selected.</li> </ul> |     |                            |                        |
| Digital inputs   |     |                            |                        |
| Use shielded twisted-pair cables for digital signals.  |     |                            |                        |
| DI3, DI4:  |     |                            |                        |
| <u>In scalar control (default):</u> See <b>Menu &gt; Primary settings &gt; Start, stop, reference &gt; Constant frequencies</b> or parameter group 28 Frequency reference chain.   |     |                            |                        |
| <u>In vector control:</u> See <b>Menu &gt; Primary settings &gt; Start, stop, reference &gt; Constant speeds</b> or parameter group 22 Speed reference selection.  |     |                            |                        |
| DI3  | DI4 | Operation/Parameter        |                        |
|  |     | Scalar control (default)   | Vector control         |
| 0  | 0   | Set frequency through AI1  | Set speed through AI1  |
| 1  | 0   | 28.26 Constant frequency 1 | 22.26 Constant speed 1 |
| 0  | 1   | 28.27 Constant frequency 2 | 22.27 Constant speed 2 |
| 1  | 1   | 28.28 Constant frequency 3 | 22.28 Constant speed 3 |

DI5:

In scalar control (default): See **Menu - Primary settings - Ramps** or parameter group 28 Frequency reference chain.

In vector control: See **Menu - Primary settings - Ramps** or parameter group 23 Speed reference ramp.

| DI5 | Ramp set | Parameters   |  |
|-----|----------|--|--|
|     |          | Scalar control (default)   | Vector control   |
| 0   | 1        | 28.72 Freq acceleration time 1<br>28.73 Freq deceleration time 1 | 23.12 Acceleration time 1<br>23.13 Deceleration time 1 |
| 1   | 2        | 28.74 Freq acceleration time 2<br>28.75 Freq deceleration time 2 | 23.14 Acceleration time 2<br>23.15 Deceleration time 2 |

DI6:

With option +E205 in frames R10 and R11, digital input DI6 is reserved for internal overtemperature supervision of the cabinet. See section [DI6 for internal overtemperature supervision with option +E205 in frames R10 and R11 \(page 136\)](#).



**WARNING!** Connect an external AC power supply (24 V AC) only to control unit connectors 40 and 41. If you connect it to connector AGND, DGND or SGND, damage to the power supply or control unit can occur.

## Additional information on the control connections

### ■ Embedded EIA-485 fieldbus connection

The EIA-485 network uses shielded, twisted-pair cable with a characteristic impedance of 100...130 ohm for data signaling. The distributed capacitance between conductors is less than 100 pF per meter (30 pF per foot). Distributed capacitance between conductors and shield is less than 200 pF per meter (60 pF per foot). Foil or braided shields are acceptable.

Connect the cable to the EIA-485 terminal on the control unit. Obey these wiring instructions:

- Attach the cable shields together at each drive, but do not connect them to the drive.
- Connect the cable shields only to the grounding terminal in the automation controller.
- Connect the signal ground (DGND) conductor to the signal ground reference terminal in the automation controller. If the automation controller does not have a signal ground reference terminal, connect the signal ground conductor to the cable shield through a 100 ohm resistor, preferably near the automation controller.

Connection examples are shown below.

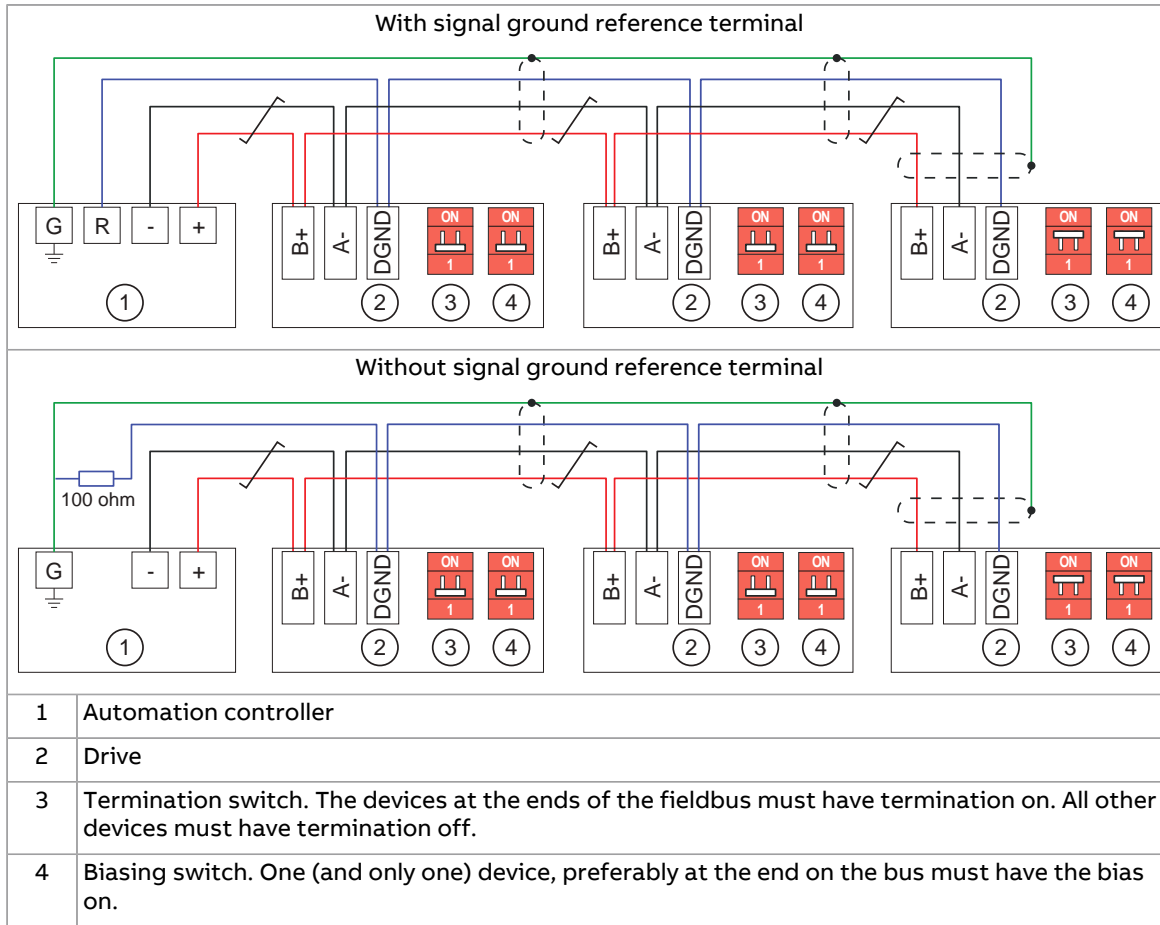

■ **Connecting motor temperature sensors to the drive**

IEC/EN 60664 requires double or reinforced insulation between the control unit and the live parts of the motor. To achieve this, use an CMOD-02 I/O extension module or CPTC-02 ATEX-certified thermistor protection module. Refer to section [Implementing a motor temperature sensor connection](#) and chapter [CMOD-02 multifunction extension module \(external 24 V AC/DC and isolated PTC interface\)](#) (page 311).

■ **DI6 for internal overtemperature supervision with option +E205 in frames R10 and R11**

With option +E205, digital input DI6 is used by default for the internal overtemperature supervision of the cabinet in frames R10 and R11. The I/O connection is shown below.

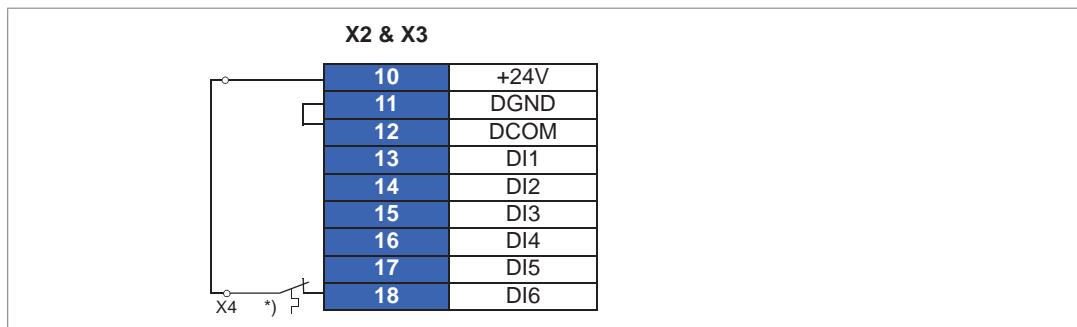

\*) Internal overtemperature supervision of the cabinet is connected between DI6 and +24V auxiliary voltage supply.



If DI6 is to be used for another purpose, change the overtemperature supervision wiring from DI6 to another free digital input either on the control unit or on the CMOD-01 multifunction extension module. Activate the overtemperature supervision in the new digital input with these parameter settings:

1. Select the correct digital input from parameter 31.01 External event 1 source.
2. Check that parameter 31.02 External event 1 type is set to Fault = 0.

For more information, refer to the firmware manual.



#### **WARNING!**

Always connect the internal overtemperature supervision of the drive cabinet to a free digital input or to CMOD-01 multifunction extension module if disconnected from digital input DI6. Activate the change. Disconnection of overtemperature supervision leads to overtemperature and can damage the drive.

## ■ PNP configurations for digital inputs

### PNP configurations with option +L504

Internal and external +24 V power supply connections with option +L504 for PNP configuration are shown below.

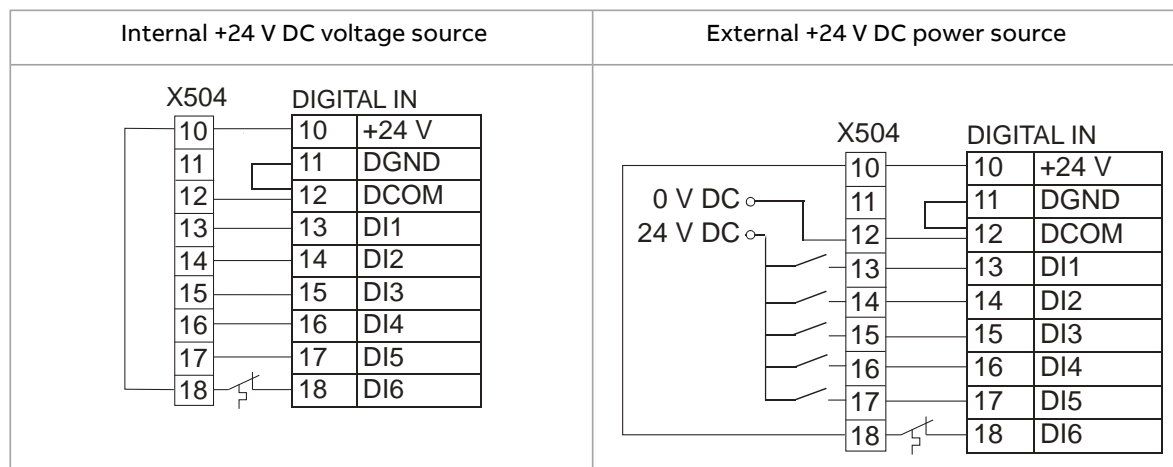

**PNP configurations without option +L504**

Internal and external +24 V power supply connections without option +L504 for PNP configuration are shown below.

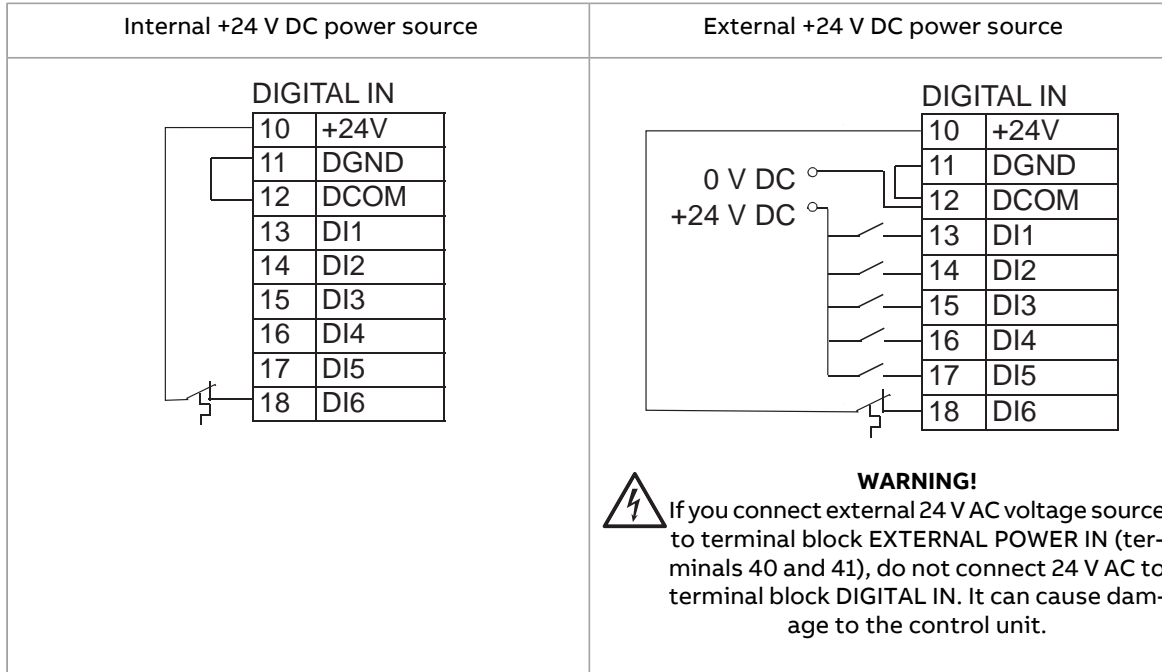

■ **NPN configurations for digital inputs**

**NPN configurations with option +L504**

Internal and external +24 V power supply connections for NPN configuration are shown below.

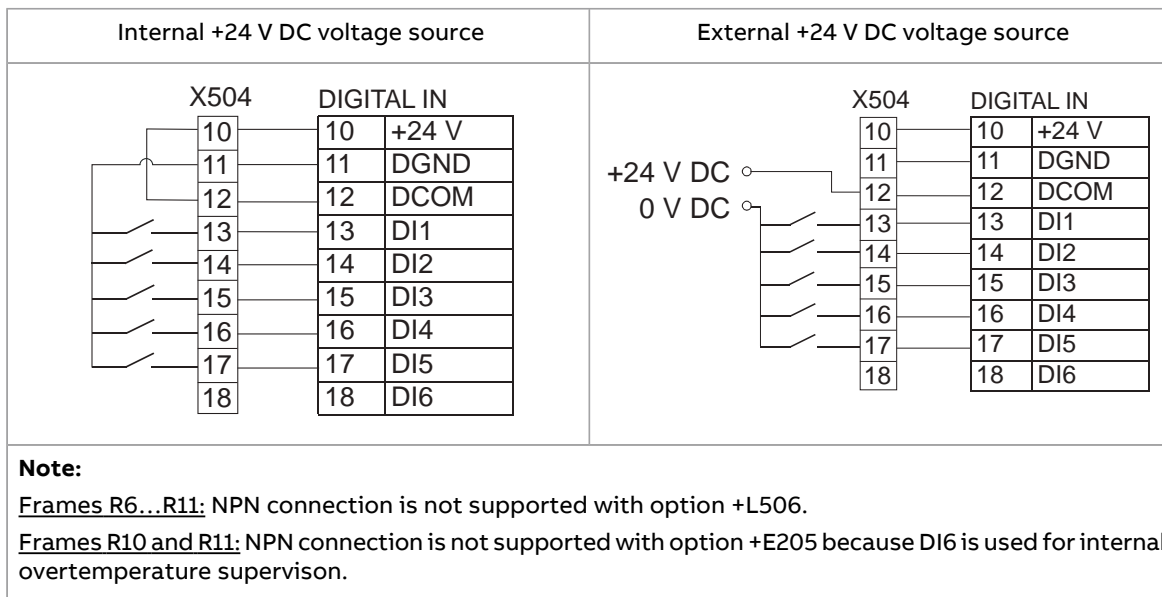

**NPN configurations without option +L504**

Internal and external +24 V power supply connections without option +L504 for NPN configuration are shown below.

| Internal +24 V DC voltage source   | External +24 V DC voltage source |       |    |      |    |      |    |     |    |     |    |     |    |     |    |     |    |     |  |    |       |    |      |    |      |    |     |    |     |    |     |    |     |    |     |    |     |
|--|----------------------------------|-------|----|------|----|------|----|-----|----|-----|----|-----|----|-----|----|-----|----|-----|--|----|-------|----|------|----|------|----|-----|----|-----|----|-----|----|-----|----|-----|----|-----|
| <p style="text-align: center;">DIGITAL IN</p> <table border="1"> <tr><td>10</td><td>+24 V</td></tr> <tr><td>11</td><td>DGND</td></tr> <tr><td>12</td><td>DCOM</td></tr> <tr><td>13</td><td>DI1</td></tr> <tr><td>14</td><td>DI2</td></tr> <tr><td>15</td><td>DI3</td></tr> <tr><td>16</td><td>DI4</td></tr> <tr><td>17</td><td>DI5</td></tr> <tr><td>18</td><td>DI6</td></tr> </table> | 10                               | +24 V | 11 | DGND | 12 | DCOM | 13 | DI1 | 14 | DI2 | 15 | DI3 | 16 | DI4 | 17 | DI5 | 18 | DI6 | <p style="text-align: center;">DIGITAL IN</p> <table border="1"> <tr><td>10</td><td>+24 V</td></tr> <tr><td>11</td><td>DGND</td></tr> <tr><td>12</td><td>DCOM</td></tr> <tr><td>13</td><td>DI1</td></tr> <tr><td>14</td><td>DI2</td></tr> <tr><td>15</td><td>DI3</td></tr> <tr><td>16</td><td>DI4</td></tr> <tr><td>17</td><td>DI5</td></tr> <tr><td>18</td><td>DI6</td></tr> </table> | 10 | +24 V | 11 | DGND | 12 | DCOM | 13 | DI1 | 14 | DI2 | 15 | DI3 | 16 | DI4 | 17 | DI5 | 18 | DI6 |
| 10   | +24 V                            |       |    |      |    |      |    |     |    |     |    |     |    |     |    |     |    |     |  |    |       |    |      |    |      |    |     |    |     |    |     |    |     |    |     |    |     |
| 11   | DGND                             |       |    |      |    |      |    |     |    |     |    |     |    |     |    |     |    |     |  |    |       |    |      |    |      |    |     |    |     |    |     |    |     |    |     |    |     |
| 12   | DCOM                             |       |    |      |    |      |    |     |    |     |    |     |    |     |    |     |    |     |  |    |       |    |      |    |      |    |     |    |     |    |     |    |     |    |     |    |     |
| 13   | DI1                              |       |    |      |    |      |    |     |    |     |    |     |    |     |    |     |    |     |  |    |       |    |      |    |      |    |     |    |     |    |     |    |     |    |     |    |     |
| 14   | DI2                              |       |    |      |    |      |    |     |    |     |    |     |    |     |    |     |    |     |  |    |       |    |      |    |      |    |     |    |     |    |     |    |     |    |     |    |     |
| 15   | DI3                              |       |    |      |    |      |    |     |    |     |    |     |    |     |    |     |    |     |  |    |       |    |      |    |      |    |     |    |     |    |     |    |     |    |     |    |     |
| 16   | DI4                              |       |    |      |    |      |    |     |    |     |    |     |    |     |    |     |    |     |  |    |       |    |      |    |      |    |     |    |     |    |     |    |     |    |     |    |     |
| 17   | DI5                              |       |    |      |    |      |    |     |    |     |    |     |    |     |    |     |    |     |  |    |       |    |      |    |      |    |     |    |     |    |     |    |     |    |     |    |     |
| 18   | DI6                              |       |    |      |    |      |    |     |    |     |    |     |    |     |    |     |    |     |  |    |       |    |      |    |      |    |     |    |     |    |     |    |     |    |     |    |     |
| 10   | +24 V                            |       |    |      |    |      |    |     |    |     |    |     |    |     |    |     |    |     |  |    |       |    |      |    |      |    |     |    |     |    |     |    |     |    |     |    |     |
| 11   | DGND                             |       |    |      |    |      |    |     |    |     |    |     |    |     |    |     |    |     |  |    |       |    |      |    |      |    |     |    |     |    |     |    |     |    |     |    |     |
| 12   | DCOM                             |       |    |      |    |      |    |     |    |     |    |     |    |     |    |     |    |     |  |    |       |    |      |    |      |    |     |    |     |    |     |    |     |    |     |    |     |
| 13   | DI1                              |       |    |      |    |      |    |     |    |     |    |     |    |     |    |     |    |     |  |    |       |    |      |    |      |    |     |    |     |    |     |    |     |    |     |    |     |
| 14   | DI2                              |       |    |      |    |      |    |     |    |     |    |     |    |     |    |     |    |     |  |    |       |    |      |    |      |    |     |    |     |    |     |    |     |    |     |    |     |
| 15   | DI3                              |       |    |      |    |      |    |     |    |     |    |     |    |     |    |     |    |     |  |    |       |    |      |    |      |    |     |    |     |    |     |    |     |    |     |    |     |
| 16   | DI4                              |       |    |      |    |      |    |     |    |     |    |     |    |     |    |     |    |     |  |    |       |    |      |    |      |    |     |    |     |    |     |    |     |    |     |    |     |
| 17   | DI5                              |       |    |      |    |      |    |     |    |     |    |     |    |     |    |     |    |     |  |    |       |    |      |    |      |    |     |    |     |    |     |    |     |    |     |    |     |
| 18   | DI6                              |       |    |      |    |      |    |     |    |     |    |     |    |     |    |     |    |     |  |    |       |    |      |    |      |    |     |    |     |    |     |    |     |    |     |    |     |
| <p><b>Note:</b></p> <p><u>Frames R6...R11:</u> NPN connection is not supported with option +L506.</p> <p><u>Frames R10 and R11:</u> NPN connection is not supported with option +E205 because DI6 is used for internal overtemperature supervision.</p>  |                                  |       |    |      |    |      |    |     |    |     |    |     |    |     |    |     |    |     |  |    |       |    |      |    |      |    |     |    |     |    |     |    |     |    |     |    |     |

### ■ Connection for obtaining 0...10 V from analog output 2 (AO2)

To obtain 0...10 V from analog output AO2, connect a 500 ohm resistor (or two 1 kohm resistors in parallel) between analog output AO2 and analog common ground AGND.

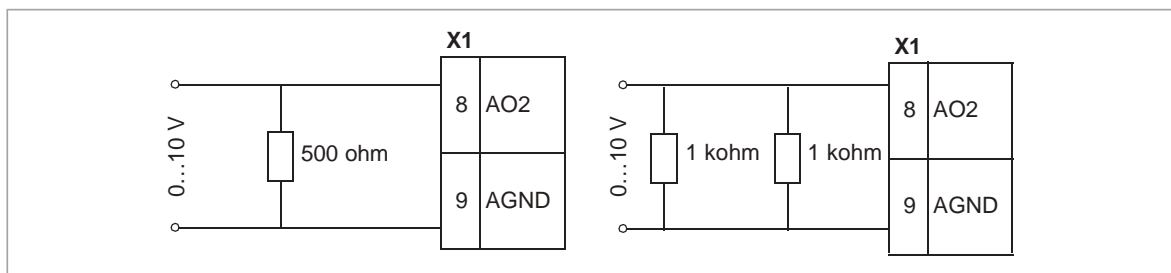

### ■ Connection examples of two-wire and three-wire sensors to analog input (AI2)

**Note:** The maximum capability of the auxiliary voltage output (24 V DC [250 mA]) must not be exceeded.

An example of a two-wire sensor/transmitter supplied by the drive auxiliary voltage output is shown below. Set the input signal to 4...20 mA, not 0...20 mA.

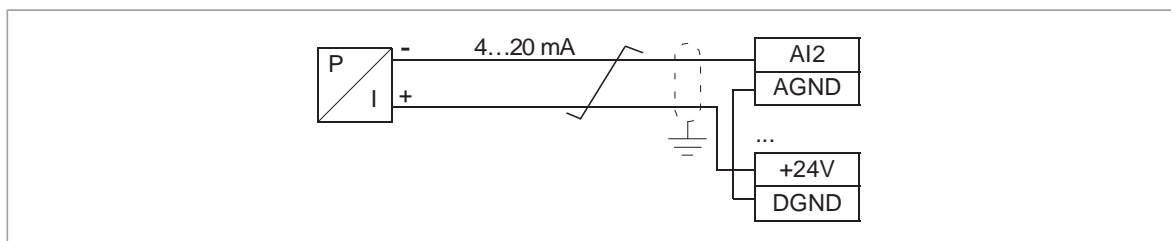

An example of a three-wire sensor/transmitter supplied by the drive auxiliary voltage output is shown below. The sensor is supplied through its current output and the drive

feeds the supply voltage (+24 V DC). Thus the output signal must be 4...20 mA, not 0...20 mA.

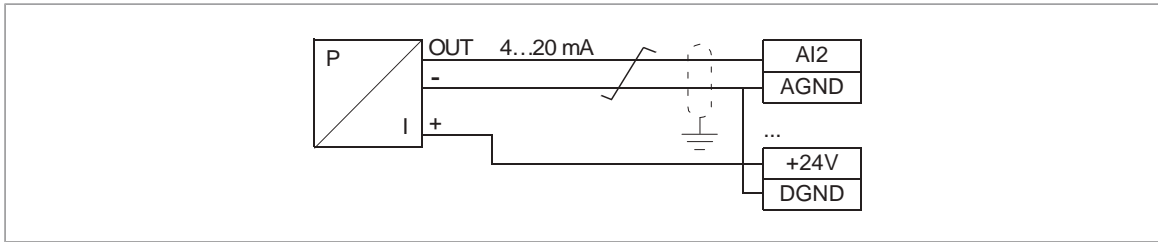

■ **DI5 as frequency input**

For setting the parameters for the digital frequency input, see the firmware manual.

■ **Safe torque off (X4)**

For the drive to start, both connections (+24 V DC to IN1 and +24 V DC to IN2) must be closed. By default, the terminal block has jumpers to close the circuit.

Remove the jumpers before connecting an external Safe torque off circuitry to the drive. See also chapter [The Safe torque off function \(page 269\)](#).

**Note:** Only 24 V DC can be used for STO. Only PNP input configuration can be used.

## CCU-24 technical data

Digital inputs DI1...DI5 also support 10...24 V AC.



Tightening torques: 0.5 ... 0.6 N·m (4.4 ... 5.3 lbf·in)

Wire strip length 7...8 mm (0.3 in)

|  |   |
|--|---|
| CCU-24 only:<br>External power supply<br>(Term. 40, 41)              | Maximum power: 36 W, 1.50 A at 24 V AC/DC ±10% as standard<br>Terminal size: 0.14...2.5 mm <sup>2</sup> (26...14 AWG)   |
| External power supply<br>through option module<br>CMOD-01 or CMOD-02 | Maximum power: 25 W, 1.04 A at 24 V AC/DC ±10% as standard<br>Terminal size: 0.2 ... 2.5 mm <sup>2</sup> (24 ... 14 AWG)  |
| +24 V DC output<br>(Term. 10)  | Total load capacity of this outputs is 6.0 W (250 mA / 24 V) minus the power taken by the option modules installed on board.<br>CCU-24: Terminal size: 0.14 ... 2.5 mm <sup>2</sup> (26 ... 14 AWG) |

|   |   |
|---|---|
| <p>Digital inputs DI1...DI6<br/>(Term. 13...18)</p>                         | <p>Input type: NPN/PNP<br/>Terminal size: 0.14 ... 1.5 mm<sup>2</sup> (26 ... 16 AWG)</p> <p><u>DI1...DI4 (Term. 13...16)</u><br/>12/24 V DC logic levels: "0" &lt; 4 V, "1" &gt; 8 V<br/><math>R_{in}</math>: 3 kohm<br/>Hardware filtering: 0.04 ms, digital filtering: 2 ms sampling</p> <p><u>DI5 (Term.17)</u><br/>Can be used as a digital or frequency input.<br/>12/24 V DC logic levels: "0" &lt; 4 V, "1" &gt; 8 V<br/><math>R_{in}</math>: 3 kohm<br/>Max. frequency: 16 kHz<br/>Symmetrical signal (duty cycle D = 0.50)</p> <p><u>DI6 (Term.18)</u><br/>Can be used as a digital or PTC input.<br/>12/24 V DC logic levels: "0" &lt; 3 V, "1" &gt; 8 V<br/><math>R_{in}</math>: 3 kohm<br/>Max. frequency: 16 kHz<br/>Symmetrical signal (duty cycle D = 0.50)<br/>Hardware filtering: 0.04 ms, digital filtering: 2 ms sampling</p> <p><b>Note:</b> DI6 is not supported in the NPN configuration.<br/>PTC mode – PTC thermistor can be connected between DI6 and +24 V DC:<br/>&lt; 1.5 kohm = '1' (low temperature), &gt; 4 kohm = '0' (high temperature),<br/>open circuit = '0' (high temperature).<br/>DI6 is not a reinforced/double insulated input. Connecting the motor<br/>PTC sensor to this input requires usage of a reinforced/double insulated<br/>PTC sensor inside the motor</p> |
| <p>Relay outputs RO1...RO3<br/>(Term. 19...27)</p>                          | <p>250 V AC / 30 V DC, 2 A. Terminal size: 0.14 ... 1.5 mm<sup>2</sup> (26 ... 16 AWG)<br/>CCU-24: See section <a href="#">Isolation areas (CCU-24) (page 142)</a>.</p>   |
| <p>Analog inputs AI1 and AI2<br/>(Term. 2 and 5)</p>                        | <p>Current/voltage input mode selected with a parameter, see <a href="#">Connecting motor temperature sensors to the drive (page 136)</a>.<br/>Current input: 0(4)...20 mA, <math>R_{in}</math>: 100 ohm<br/>Voltage input: 0(2)...10 V, <math>R_{in}</math>: &gt; 200 kohm<br/>Terminal size: 0.14 ... 1.5 mm<sup>2</sup> (26 ... 16 AWG)<br/>Inaccuracy: typical <math>\pm 1\%</math>, max. <math>\pm 1.5\%</math> of full scale<br/>Inaccuracy for Pt100 sensors: 10 °C (50 °F)</p>  |
| <p>Analog outputs AO1 and AO2<br/>(Term. 7 and 8)</p>                       | <p>Current/voltage output mode for AO1 selected with a parameter, see <a href="#">Connection for obtaining 0...10 V from analog output 2 (AO2) (page 139)</a>.<br/>Current output: 0...20 mA, <math>R_{load}</math>: &lt; 500 ohm<br/>Voltage input: 0...10 V, <math>R_{load}</math>: &gt; 100 kohm (AO1 only)<br/>Terminal size: 0.14 ... 1.5 mm<sup>2</sup> (26 ... 16 AWG)<br/>Inaccuracy: <math>\pm 1\%</math> of full scale (in voltage and current modes)</p>   |
| <p>Reference voltage output for<br/>analog inputs +10V DC (Term.<br/>4)</p> | <p>Max. 20 mA output<br/>Inaccuracy: <math>\pm 1\%</math></p>   |
| <p>Embedded fieldbus (X5)</p>   | <p>Connector pitch 5 mm, maximum wire size 2.5 mm<sup>2</sup> (14 AWG)<br/>Physical layer: EIA-485<br/>Cable type: Shielded twisted pair cable with twisted pair for data and a<br/>wire or pair for signal ground, nominal impedance 100...165 ohms, for<br/>example Belden 9842<br/>Transmission rate: 9.6 ... 115.2 kbit/s<br/>Termination by switch</p>   |
| <p>Safe torque off (STO) inputs<br/>IN1 and IN2 (Term. 37 and 38)</p>       | <p>24 V DC logic levels: "0" &lt; 5 V, "1" &gt; 13 V<br/><math>R_{in}</math>: 2.47 kohm<br/>CCU-24: terminal size: 0.14 ... 2.5 mm<sup>2</sup> (26 ... 14 AWG)</p>  |

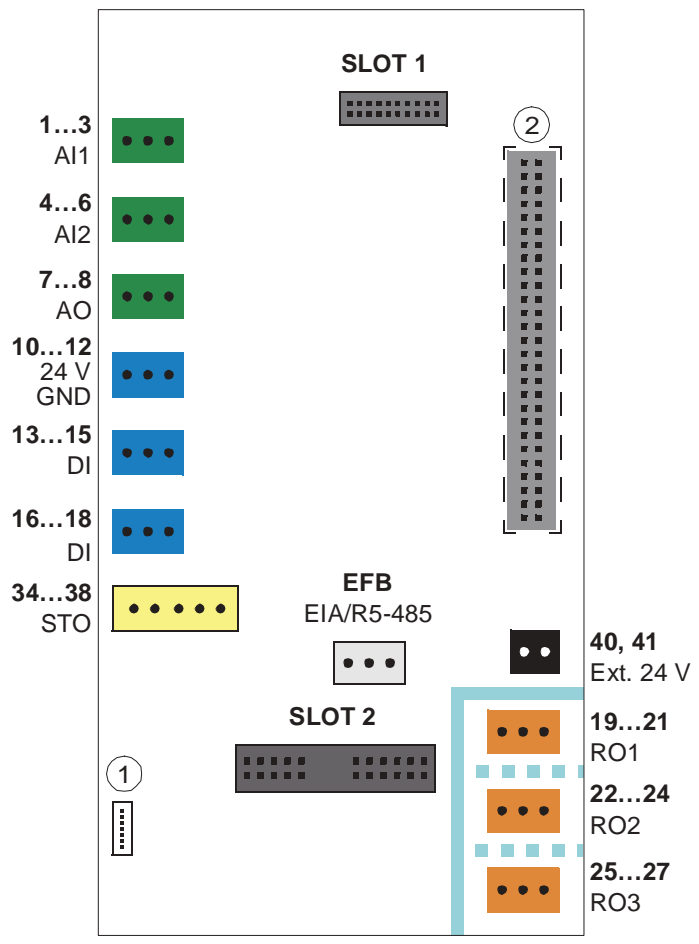
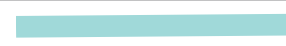
142 Control unit

|   |   |   |
|---|---|---|
| Control panel - drive connection  | EIA-485, male RJ-45 connector, max. cable length 100 m (328 ft)                     |   |
| Control panel - PC connection   | USB Type Mini-B, max. cable length 2 m (6.5 ft)                                     |   |
| Isolation areas (CCU-24)  |  |   |
|   | 1   | Panel port  |
|   | 2   | Power unit connection at the bottom of the control unit |
|    | Reinforced insulation (IEC/EN 61800-5-1:2007, UL 61800-5-1 First edition)           |   |
|    | Functional insulation (IEC/EN 61800-5-1:2007, UL 61800-5-1 First edition)           |   |
| <p>The terminals on the control unit fulfill the Protective Extra Low Voltage (PELV) requirements (EN 50178): There is reinforced insulation between the user terminals which only accept ELV voltages and terminals that accept higher voltages (relay outputs).</p> <p>Note: There is functional insulation also between the individual relay outputs.</p> <p>Note: There is reinforced insulation on the power unit.</p> |   |   |

Ground isolation diagram (CCU-24)

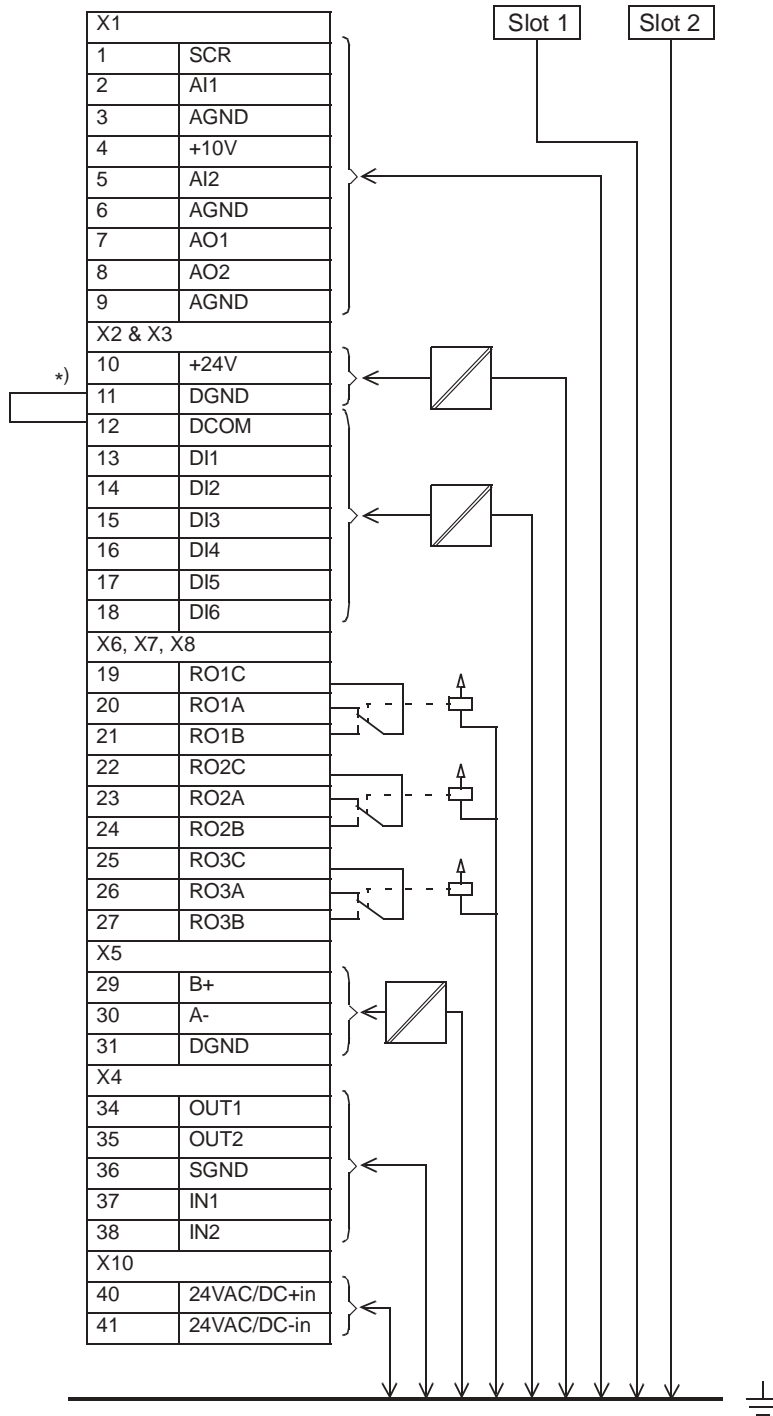

\*) Jumper installed at factory





## 8

# Installation checklist

## Contents of this chapter

This chapter contains a checklist for the mechanical and electrical installation of the drive.

## Checklist

Examine the mechanical and electrical installation of the drive before start-up. Go through the checklist together with another person.



### WARNING!

Obey the safety instructions of the drive. If you ignore them, injury or death, or damage to the equipment can occur. If you are not a qualified electrical professional, do not do installation, commissioning or maintenance work.



### WARNING!

Do the steps in section [Electrical safety precautions \(page 18\)](#) before you start the work.

| Make sure that ...   | <input checked="" type="checkbox"/> |
|--|-------------------------------------|
| The ambient operating conditions meet the drive ambient conditions specification and enclosure rating (IP code).                                   | <input type="checkbox"/>            |
| The supply voltage matches the nominal input voltage of the drive. See the type designation label.   | <input type="checkbox"/>            |
| The insulation resistance of the input power cable, motor cable and motor is measured according to local regulations and the manuals of the drive. | <input type="checkbox"/>            |
| The drive cabinet is attached to the floor, and if necessary due to vibration etc, also by its top to the wall or roof.                            | <input type="checkbox"/>            |
| The cooling air can flow freely in and out of the drive.   | <input type="checkbox"/>            |

146 Installation checklist

|  |                                     |
|--|-------------------------------------|
| <b>Make sure that ...</b>  | <input checked="" type="checkbox"/> |
| <u>If the drive is connected to a network other than a symmetrically grounded TN-S system:</u> You have done all the required modifications (for example, you may need to disconnect the EMC filter or ground-to-phase varistor) the electrical installation instructions.   | <input type="checkbox"/>            |
| There is an adequately sized protective earth (ground) conductor(s) between the drive and the switchboard, the conductor is connected to correct terminal, and the terminal is tightened to the correct torque.<br>Grounding has also been measured according to the regulations.  | <input type="checkbox"/>            |
| The input power cable is connected to the correct terminals, the phase order is correct, and the terminals are tightened to the correct torque.  | <input type="checkbox"/>            |
| There is an adequately sized protective earth (ground) conductor between the motor and the drive. The conductor is connected to the correct terminal, and the terminal is tightened to the correct torque.<br>Grounding has also been measured according to the regulations.   | <input type="checkbox"/>            |
| The motor cable is connected to the correct terminals, the phase order is correct, and the terminals are tightened to the correct torque.  | <input type="checkbox"/>            |
| The motor cable is routed away from other cables.  | <input type="checkbox"/>            |
| No power factor compensation capacitors are connected to the motor cable.  | <input type="checkbox"/>            |
| The control cables are connected to the correct terminals, and the terminals are tightened to the correct torque.  | <input type="checkbox"/>            |
| The voltage setting of the auxiliary voltage transformers (if any) is correct. See the electrical installation instructions.   | <input type="checkbox"/>            |
| <u>If a drive bypass connection will be used:</u> The direct-on-line contactor of the motor and the drive output contactor are either mechanically and/or electrically interlocked, that is, they cannot be closed at the same time. A thermal overload device must be used for protection when bypassing the drive. Refer to local codes and regulations. | <input type="checkbox"/>            |
| There are no tools, foreign objects or dust from drilling inside the drive.  | <input type="checkbox"/>            |
| The area in front of the drive is clean: the drive cooling fan cannot draw any dust or dirt inside.  | <input type="checkbox"/>            |
| The terminal box cover of the motor is in place. Cabinet shrouds are in place and doors are closed.  | <input type="checkbox"/>            |
| The motor and the driven equipment are ready for power-up.   | <input type="checkbox"/>            |

## 9

## Start-up

### Contents of this chapter

This chapter contains the start-up procedure of the drive. The default device designations (if any) are given in brackets after the name, for example "main switch-disconnector (Q1)". The same device designations are also used in the circuit diagrams, typically.

### Start-up procedure

|   |                                     |
|---|-------------------------------------|
| <b>Action</b>   | <input checked="" type="checkbox"/> |
| <b>Safety</b>   |                                     |
|  <b>WARNING!</b><br>Obey the safety instructions during the start-up procedure. See chapter <a href="#">Safety instructions (page 15)</a> .  | <input type="checkbox"/>            |
| <b>Basic checks with no voltage connected</b>   |                                     |
| Check the mechanical and electrical installation of the drive. See <a href="#">Installation checklist (page 145)</a> .  | <input type="checkbox"/>            |
| <u>For drives with Pt100 relays (option +(n)L506):</u> <ul style="list-style-type: none"> <li>• Check the connections against the circuit diagrams of the delivery.</li> <li>• Set the alarm and trip levels of the Pt100 relays.</li> </ul> Set the alarm and trip levels of the Pt100 relay as low as possible based on the operating temperature and test results of the machine. The trip level can be set, for example, 10 °C higher than what the temperature of the machine is at maximal load in the maximum environmental temperature.<br>ABB recommends to set the operating temperatures of the relay, typically for example, as follows: <ul style="list-style-type: none"> <li>• 120...140 °C when only tripping is in use</li> <li>• alarm 120...140 °C and trip 130...150 °C when both alarm and tripping are used.</li> </ul> | <input type="checkbox"/>            |



|   |                                     |
|---|-------------------------------------|
| <b>Action</b>   | <input checked="" type="checkbox"/> |
| <b>Connecting voltage to the input terminals and auxiliary circuit</b>  |                                     |
| <b>Note:</b> Before you close the door, make sure that the main protective circuit breaker (F21) for the auxiliary voltage supply is closed.  | <input type="checkbox"/>            |
| Make sure that it is safe to connect voltage. Make sure that: <ul style="list-style-type: none"> <li>• cabinet doors are closed</li> <li>• nobody is working on the drive or circuits that have been wired from outside into the drive cabinet</li> <li>• cover of the motor terminal box is on.</li> </ul>   | <input type="checkbox"/>            |
| Close the main switch-disconnector (Q1).  | <input type="checkbox"/>            |
| <b>Setting up the drive parameters, and performing the first start</b>  |                                     |
| Setup the drive control program. See <i>Quick start-up guide for ACH580 drives with HVAC control program</i> (3AXD50000047658 [English])  | <input type="checkbox"/>            |
| <b>Powering up</b>  |                                     |
| <u>Drive with the emergency stop cat. 0 (option +Q951):</u> Reset the emergency stop relay (A61) with the emergency stop reset button (S62) on the cabinet door. Otherwise you cannot close the main contactor.   | <input type="checkbox"/>            |
| <u>Drive with the emergency stop cat. 0 (option +Q963):</u> Reset the emergency stop relay (A61) with the emergency stop reset button (S62) on the cabinet door. Otherwise you cannot start the drive because the STO signal circuit is open.   |                                     |
| <u>Drives with main contactor (Q2, option +F250):</u> Close the main contactor by turning the operating switch on the cabinet door from OFF into ON position.   | <input type="checkbox"/>            |
| Perform the first start of the drive and motor.   | <input type="checkbox"/>            |
| Stop the motor and drive.   | <input type="checkbox"/>            |
| <u>Drives with a fieldbus adapter module (optional):</u> Set the fieldbus parameters. Activate the appropriate assistant in the control program, or see the user's manual of the fieldbus adapter module, and the drive firmware manual. Not all control programs include assistants. Check that the communication works between the drive and the PLC. | <input type="checkbox"/>            |
| <b>On-load checks</b>   |                                     |
| Check that the cooling fans rotate freely in the right direction, and the air flows upwards. A paper sheet set on the intake (door) gratings stays. The fans run noiselessly.   | <input type="checkbox"/>            |
| Check that the motor starts, stops and follows the speed reference in right direction when controlled with the control panel.   | <input type="checkbox"/>            |
| Check that the motor starts, stops and follows the speed reference in right direction when controlled through the customer-specific I/O or fieldbus.  | <input type="checkbox"/>            |
| <u>Drives in which the Safe torque off control circuit is connected:</u> Test and validate the operation of the Safe torque off function. See chapter <a href="#">The Safe torque off function (page 269)</a> .   | <input type="checkbox"/>            |
| <u>Drives with an emergency stop circuit (options +Q951 and +Q963):</u> Test and validate the operation of the emergency-stop circuit. See section <a href="#">Implementing the emergency stop function (page 91)</a> .   | <input type="checkbox"/>            |



# 10

## Fault tracing

---

### Contents of this chapter

This chapter describes the fault tracing possibilities of the drive.

### Warning and fault messages

See the firmware manual for the descriptions, causes and remedies of the drive control program warning and fault messages.

---



# 11

## Maintenance

---

### Contents of this chapter

This chapter contains preventive maintenance instructions.

### Maintenance intervals

The tables show the maintenance tasks that can be done by the end user. For the ABB Service offering, contact your local ABB Service representative ([new.abb.com/contact-centers](http://new.abb.com/contact-centers)).

#### ■ Description of symbols

| Action | Description  |
|--------|--|
| I      | Inspection (visual inspection and maintenance action if needed)                    |
| P      | Performance of on/off-site work (commissioning, tests, measurements or other work) |
| R      | Replacement  |

---

## ■ Recommended maintenance intervals after start-up

| Recommended annual maintenance actions by the user |   |
|--|---|
| Action   | Description   |
| I  | IP42 air inlet and outlet meshes on the cabinet doors   |
| I  | IP54 air filters on the cabinet doors   |
| P  | Quality of supply voltage   |
| I  | Spare parts   |
| P  | Capacitor reforming for spare modules and spare capacitors, see <a href="#">Capacitors (page 186)</a> |
| I  | Tightness of terminals  |
| I  | Dustiness, corrosion or temperature   |
| P  | Heatsink cleaning   |

| Component   | Years from start-up  |   |   |    |    |    |
|---|--|---|---|----|----|----|
|   | 3  | 6 | 9 | 12 | 15 | 18 |
| <b>Cooling</b>  |  |   |   |    |    |    |
| <b>Fans, IP21 frames R6...R9</b>                          |  |   |   |    |    |    |
| Main cooling fans R6...R9 LONGLIFE                        |  |   | R |    |    | R  |
| Auxiliary cooling fan for circuit boards R6...R9 LONGLIFE |  |   | R |    |    | R  |
| <b>Fans, IP55 frames R6...R9</b>                          |  |   |   |    |    |    |
| Main cooling fans R6...R9 LONGLIFE                        |  |   | R |    |    | R  |
| Auxiliary cooling fan(s) for circuit boards R6...R9       |  |   | R |    |    | R  |
| <b>Fans, frames R10 and R11</b>                           |  |   |   |    |    |    |
| Main cooling fans   |  |   | R |    |    | R  |
| Circuit board compartment cooling fans LONGLIFE           |  |   | R |    |    | R  |
| <b>Cabinet cooling fan R6...R9</b>                        |  |   |   |    |    |    |
| Cabinet cooling fan, door (IP21, IP42, IP54)              |  |   | R |    |    | R  |
| <b>Cabinet cooling fan R10 and R11</b>                    |  |   |   |    |    |    |
| Internal LONG-LIFE 50Hz                                   |  |   | R |    |    | R  |
| Internal LONG-LIFE 60Hz                                   |  | R |   | R  |    | R  |
| Door LONG-LIFE 50Hz                                       |  |   | R |    |    | R  |
| Door LONG-LIFE 60Hz                                       |  |   | R |    |    | R  |
| IP54 50Hz   |  |   | R |    |    | R  |
| IP54 60Hz   |  | R |   | R  |    | R  |
| Cabinet cooling fan IP54                                  |  |   | R |    |    | R  |
| <b>Aging</b>  |  |   |   |    |    |    |
| Control panel battery (real-time clock)                   |  |   | R |    |    | R  |
| <b>Functional safety</b>                                  |  |   |   |    |    |    |
| Safety function test                                      | I<br>See the maintenance information of the safety function. |   |   |    |    |    |
| Safety component expiry (Mission time, $T_M$ )            | 20 years   |   |   |    |    |    |



**Note:**

- The maintenance and component replacement intervals are based on the assumption that the equipment operates within the specified ratings and ambient conditions. ABB recommends annual drive inspections to ensure the highest reliability and optimum performance.
- Long-term operation near the specified maximum ratings or ambient conditions may require shorter maintenance intervals for certain components. Contact your local ABB Service representative for additional maintenance recommendations.

## Cleaning the interior of the cabinet

---

**WARNING!**

Obey the safety instructions of the drive. If you ignore them, injury or death, or damage to the equipment can occur. If you are not a qualified electrical professional, do not do installation, commissioning or maintenance work.

---

**WARNING!**

Use a vacuum cleaner with antistatic hose and nozzle, and wear a grounding wristband. Using a normal vacuum cleaner creates static discharges which can damage circuit boards.

---

1. Stop the drive and do the steps in section [Electrical safety precautions \(page 18\)](#) before you start the work.
2. Open the cabinet door.
3. Clean the interior of the cabinet. Use a vacuum cleaner and a soft brush.
4. Clean the air inlets of the fans and air outlets of the modules (top).
5. Clean the air inlet gratings (if any) on the door.
6. Close the door.

## Cleaning the exterior of the drive

---

**WARNING!**

Obey the safety instructions of the drive. If you ignore them, injury or death, or damage to the equipment can occur. If you are not a qualified electrical professional, do not do installation, commissioning or maintenance work.

---

1. Stop the drive and do the steps in section [Electrical safety precautions \(page 18\)](#) before you start the work.
  2. Clean the exterior of the drive. Use:
    - vacuum cleaner with an antistatic hose and nozzle
    - soft brush
    - dry or damp (not wet) cleaning cloth. Moisten with clean water, or mild detergent (pH 5...9 for metal, pH 5...7 for plastic).
-



**WARNING!**

Prevent water from entering the drive. Never use excessive amount of water, a hose, steam, etc.

---

## Cleaning the air inlet (door) meshes (IP42 / UL Type 1 Filtered)

Check the dustiness of the air inlet meshes. If the dust cannot be removed by vacuum cleaning from outside through the grating holes with a small nozzle, proceed as follows:

1. Stop the drive and do the steps in section [Electrical safety precautions \(page 18\)](#) before you start the work.
2. Remove the fasteners at the top of the grating.
3. Lift the grating and pull it away from the door.
4. Vacuum clean or wash the grating on both sides.
5. Reinstall the grating in reverse order.

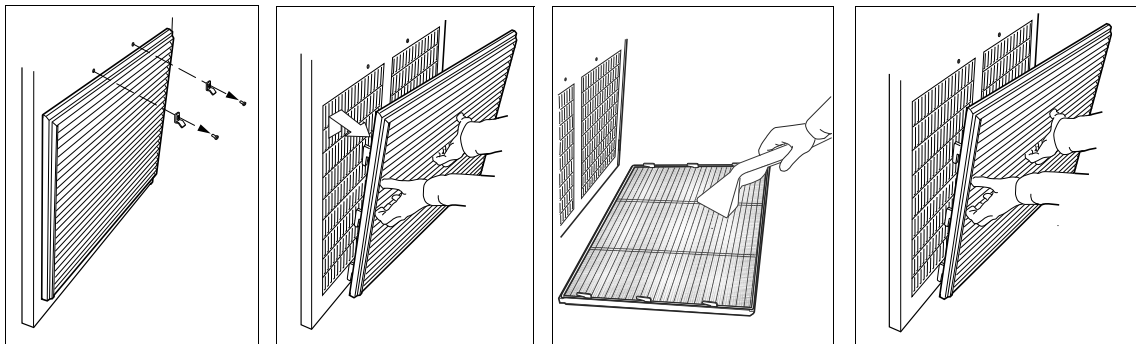

## Replacing the air filters (IP54 / UL Type 12)

Check the air filters and replace if necessary.

### ■ Inlet (door) filters (IP54 / UL Type 12)

1. Stop the drive and do the steps in section [Electrical safety precautions \(page 18\)](#) before you start the work.
2. Remove the fasteners at the top of the grating.
3. Lift the grating and pull it away from the door.
4. Remove the air filter mat.
5. Place the new filter mat in the grating the metal wire side facing the door.
6. Reinstall the grating in reverse order.

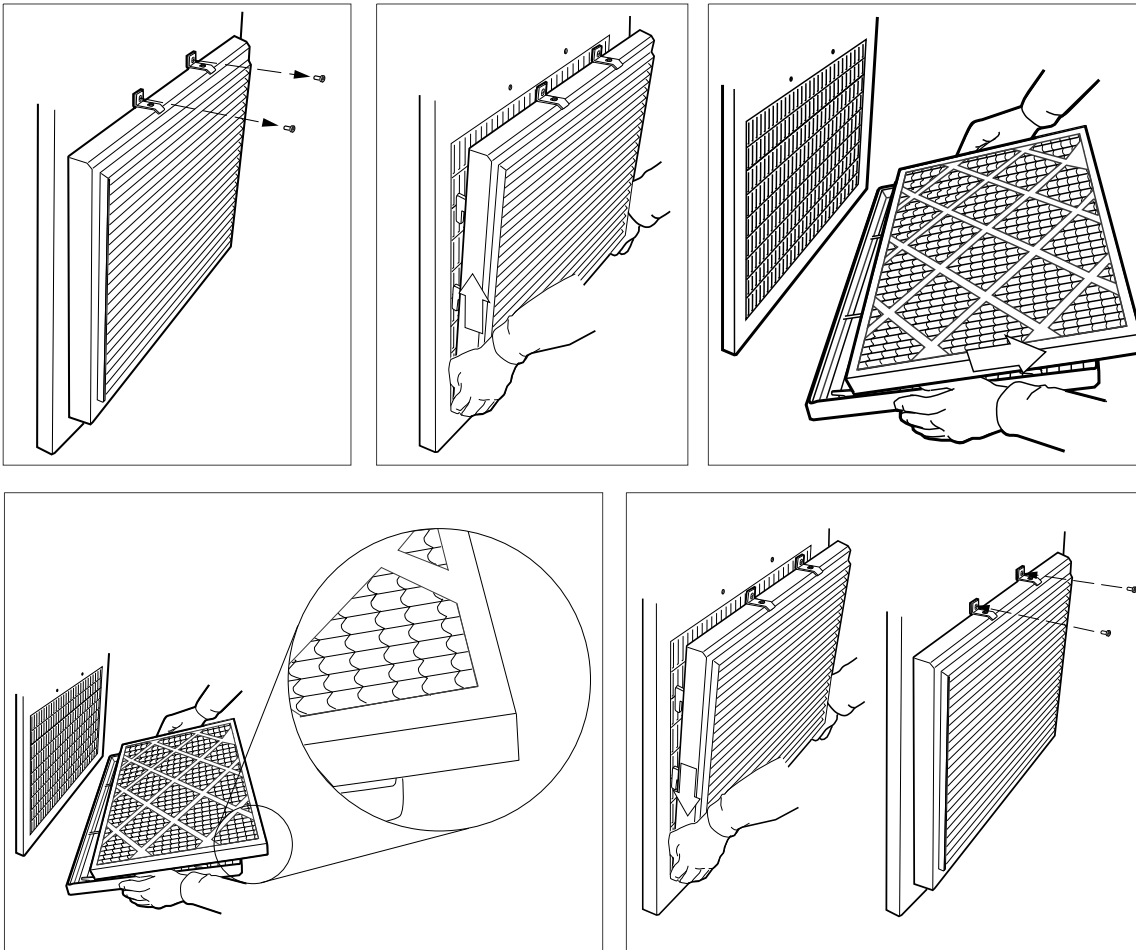

### ■ Outlet (roof) filters (IP54 / UL Type 12)

1. Remove the front and back gratings of the fan cubicle by lifting them upwards.
2. Remove the air filter mat.
3. Place the new filter mat in the grating.
4. Reinstall the gratings in reverse order.

## Cleaning the interior of the heatsink (frames R10 and R11)

The drive module heatsink fins pick up dust from the cooling air. The drive runs into overtemperature warnings and faults if the heatsink is not clean. When necessary, clean the heatsink as follows.

**WARNING!**

Obey the safety instructions of the drive. If you ignore them, injury or death, or damage to the equipment can occur. If you are not a qualified electrical professional, do not do installation, commissioning or maintenance work.

**WARNING!**

Use a vacuum cleaner with antistatic hose and nozzle. Using a normal vacuum cleaner creates static discharges which can damage circuit boards.

- 
1. Stop the drive and do the steps in section [Electrical safety precautions \(page 18\)](#) before you start the work.
  2. Remove the drive module from the cabinet. See section [Replacing the drive module \(frames R10 and R11\) \(page 174\)](#).
  3. Undo the attaching screws of the handle plate of the drive module.
  4. Remove the handle plate.
  5. Vacuum the interior of the heatsink from the opening.
  6. Blow clean compressed air (not humid or oily) upwards from the opening and, at the same time, vacuum from the top of the drive module.
  7. Reinstall the handle plate.
  8. Install the drive module back into the cabinet.

## Fans

The lifespan of the cooling fans of the drive depends on running time, ambient temperature and dust concentration. See the firmware manual for the actual signal which indicates the running time of the cooling fan. Reset the running time signal after fan replacement.

Replacement fans are available from ABB. Do not use other than ABB-specified spare parts.

---

## ■ Replacing the door fan (frames R6...R9)

**Note:** The fan is not present in all cabinet configurations.



**WARNING!**

Obey the safety instructions of the drive. If you ignore them, injury or death, or damage to the equipment can occur. If you are not a qualified electrical professional, do not do installation, commissioning or maintenance work.

---

1. Stop the drive and do the steps in section [Electrical safety precautions \(page 18\)](#) before you start the work.
2. Open the cabinet door.
3. Unplug the power supply wires.
4. Undo the two mounting screws of the fan.
5. Install the new fan in reverse order.

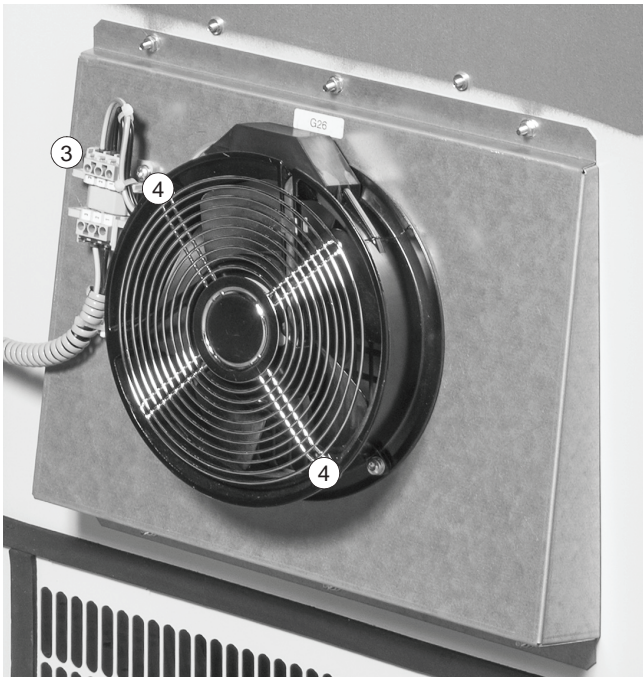

## ■ Replacing the cabinet fan (frames R6...R9)

**Note:** The fan is not present in all cabinet configurations.



### **WARNING!**

Obey the safety instructions of the drive. If you ignore them, injury or death, or damage to the equipment can occur. If you are not a qualified electrical professional, do not do installation, commissioning or maintenance work.

1. Stop the drive and do the steps in section [Electrical safety precautions \(page 18\)](#) before you start the work.
2. Open the cabinet door.
3. Unplug the power supply wires.
4. Remove the shroud.
5. Undo the mounting screws and nuts of the fan.
6. Install the new fan in reverse order.

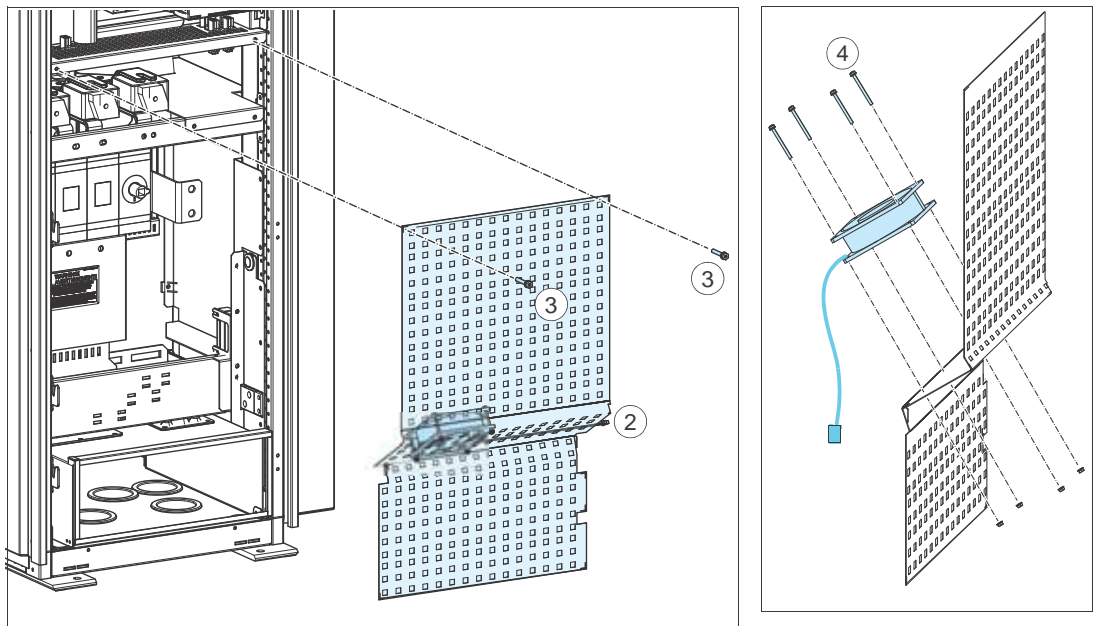

## ■ Replacing the door fan (frames R10 and R11)



### WARNING!

Obey the safety instructions of the drive. If you ignore them, injury or death, or damage to the equipment can occur. If you are not a qualified electrical professional, do not do installation, commissioning or maintenance work.

1. Stop the drive and do the steps in section [Electrical safety precautions \(page 18\)](#) before you start the work.
2. Open the cabinet door.
3. Unplug the connector of the fan power supply at the front of the mounting plate.
4. Pull the mounting plate outwards somewhat and unplug the connectors at the back of the mounting plate.
5. Remove the mounting plate.
6. Undo the fan assembly mounting screws.
7. Remove the fan and the fan grating from the mounting plate.
8. Install the new fan in reverse order.

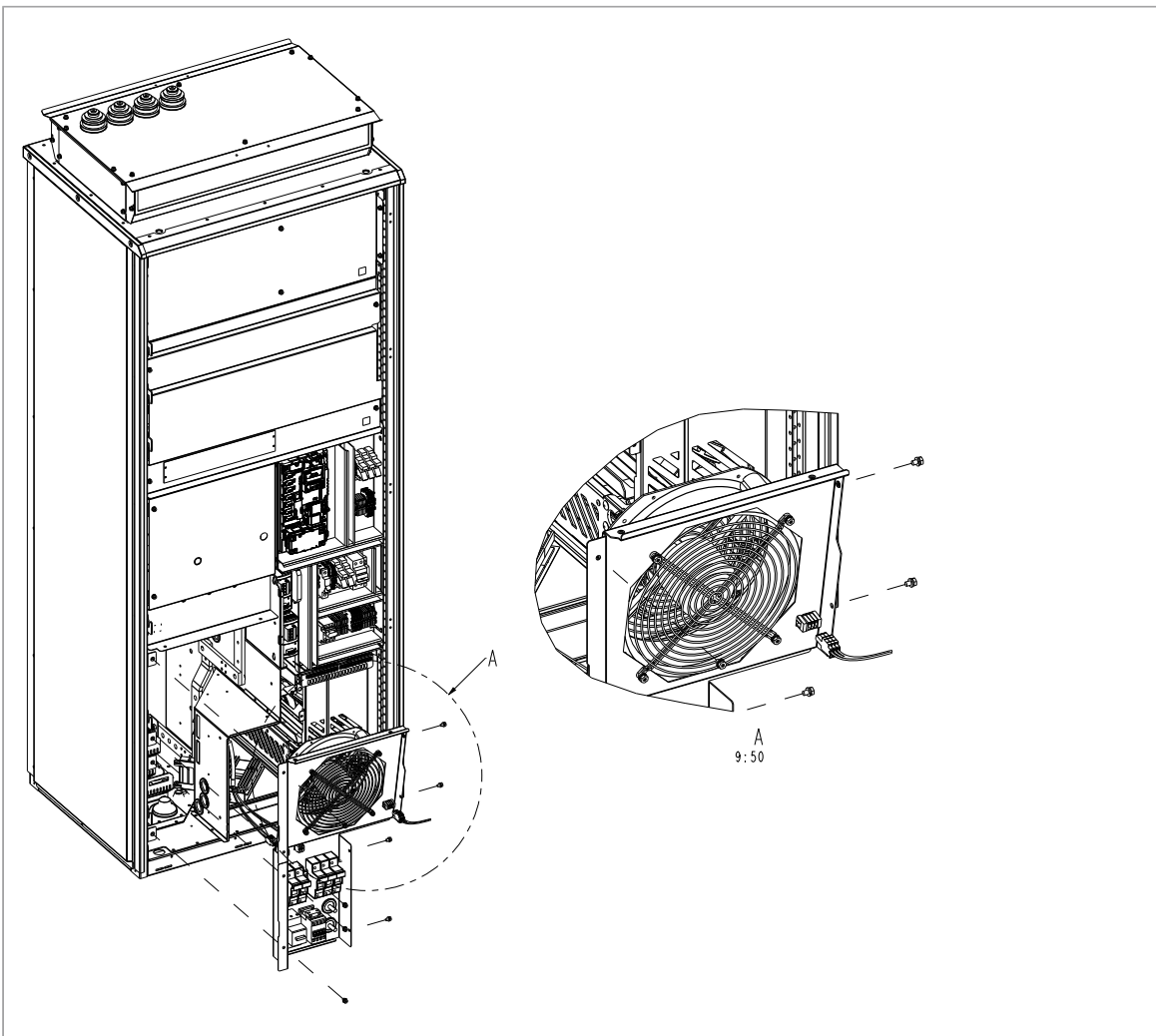



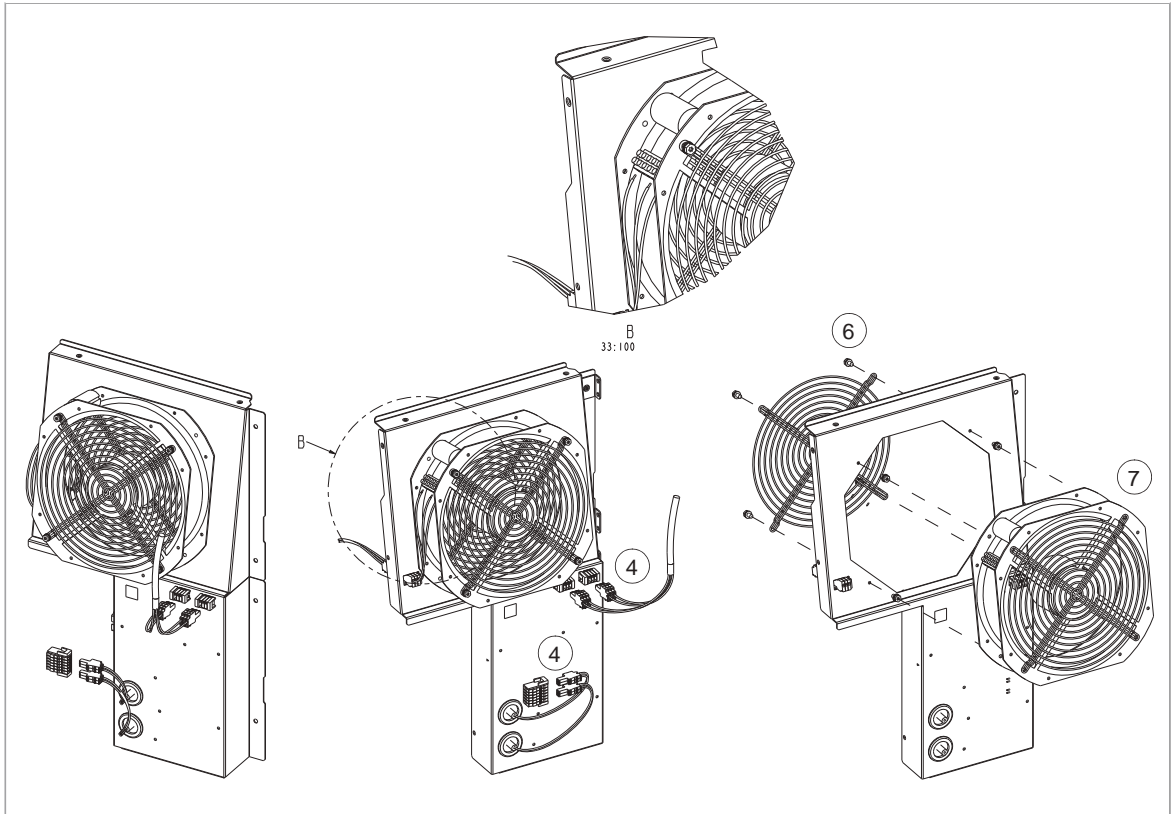

## ■ Replacing the cabinet fan (frames R10 and R11, IP54 / UL Type 12)



### WARNING!

Obey the safety instructions of the drive. If you ignore them, injury or death, or damage to the equipment can occur. If you are not a qualified electrical professional, do not do installation, commissioning or maintenance work.

1. Stop the drive and do the steps in section [Electrical safety precautions \(page 18\)](#) before you start the work.
2. Open the cabinet door.
3. Undo the fastening screws (a) of the fan mounting plate.
4. Pull the mounting plate outwards and unplug the power supply cable (b) of the fan behind the mounting plate.
5. Remove the fan mounting plate.
6. Undo the mounting screws and nuts of the fan, and take it out of the mounting plate.
7. Install the new fan in reverse order.

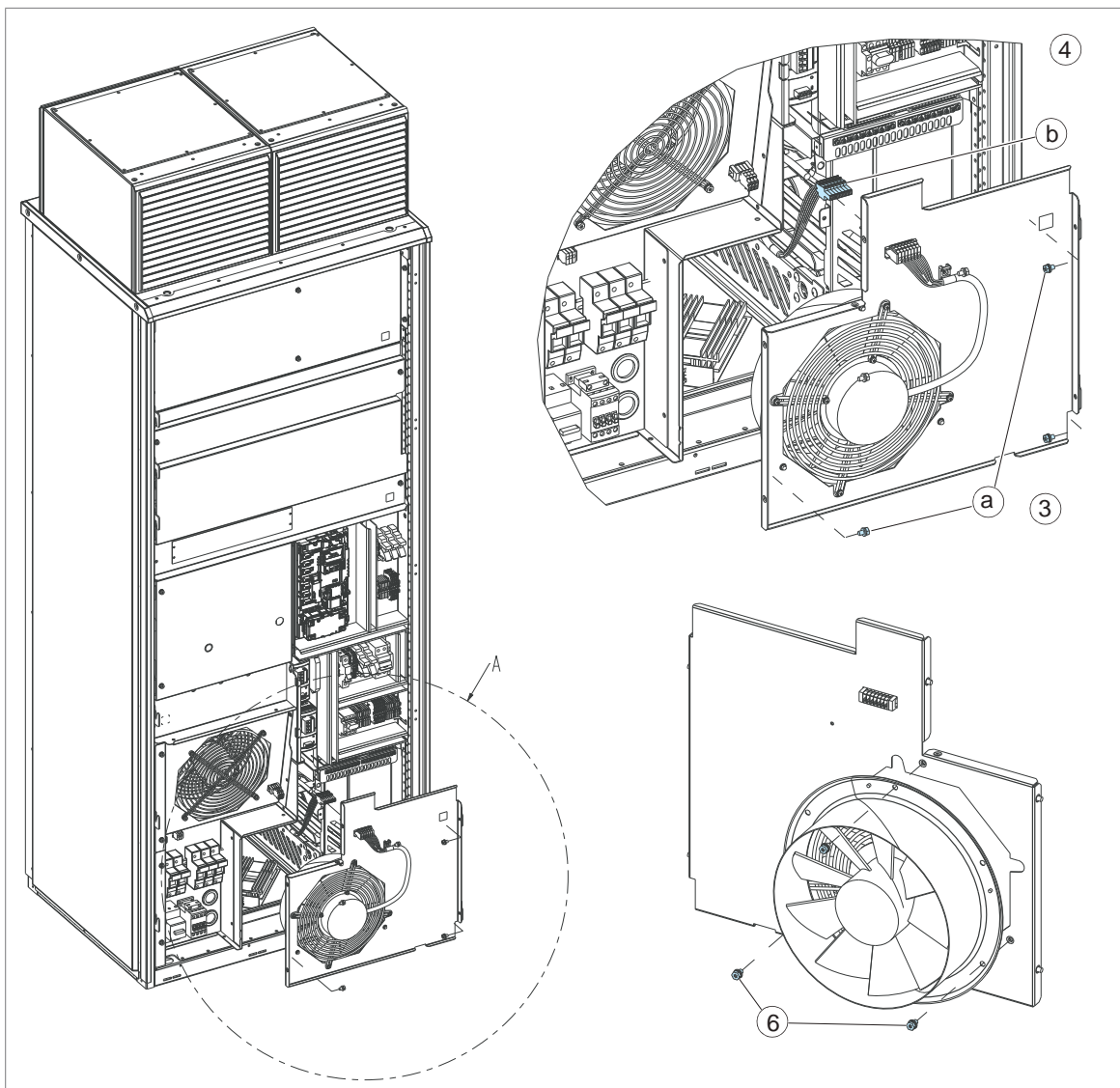

## ■ Replacing the drive module main cooling fan (frames R6...R8)



### WARNING!

Obeys the safety instructions of the drive. If you ignore them, injury or death, or damage to the equipment can occur. If you are not a qualified electrical professional, do not do installation, commissioning or maintenance work.

1. Stop the drive and do the steps in section [Electrical safety precautions \(page 18\)](#) before you start the work.
2. Open the cabinet door.
3. Remove the drive module from the cabinet as described in section [Replacing the drive module \(frames R6...R9\) \(page 168\)](#).
4. Remove the two mounting screws of the fan mounting plate at the bottom of the drive module.
5. Pull the fan mounting plate down from the side edge.
6. Unplug the fan power supply wires from the drive.
7. Lift the fan mounting plate off.
8. Remove the fan from the mounting plate.
9. Install the new fan in reverse order.
10. Reset the fan on-time counter in parameter group 5 of the drive control program.

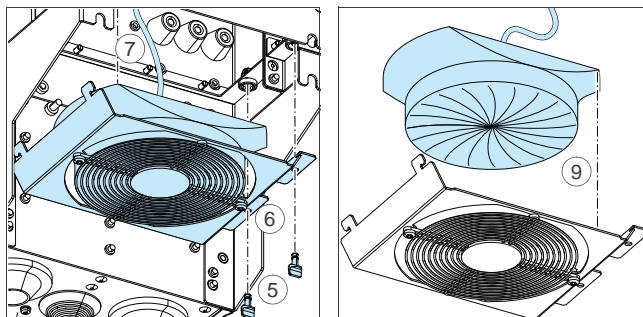

## ■ Replacing the drive module main cooling fans (frame R9)



### WARNING!

Obey the safety instructions of the drive. If you ignore them, injury or death, or damage to the equipment can occur. If you are not a qualified electrical professional, do not do installation, commissioning or maintenance work.

1. Stop the drive and do the steps in section [Electrical safety precautions \(page 18\)](#) before you start the work.
2. Open the cabinet door.
3. Remove the drive module from the cabinet as described in section [Replacing the drive module \(frames R6...R9\) \(page 168\)](#).
4. Undo the two mounting screws of the fan mounting plate at the bottom of the drive module.
5. Turn the mounting plate downwards.
6. Unplug the fan power supply wires from the drive.
7. Remove the fan mounting plate.
8. Remove the fans by removing the two mounting screws.
9. Install the new fans in reverse order.
10. Reset the fan on-time counter in parameter group 5 of the drive control program.

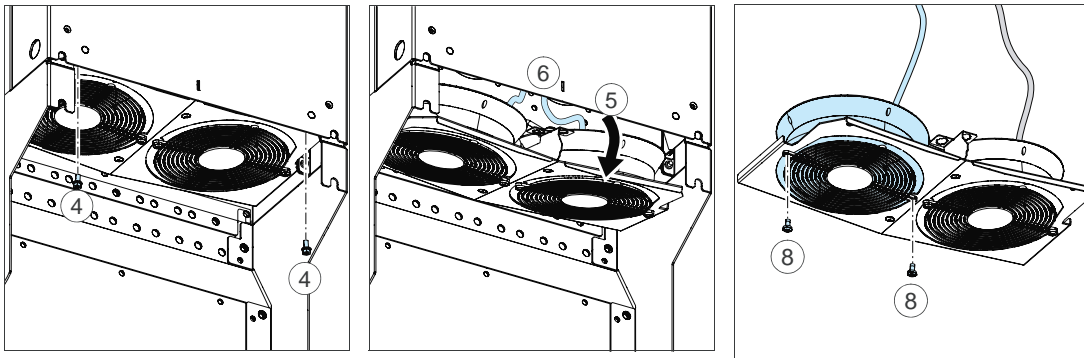

## ■ Replacing the drive module main cooling fans (frames R10 and R11)



### WARNING!

Obeys the safety instructions of the drive. If you ignore them, injury or death, or damage to the equipment can occur. If you are not a qualified electrical professional, do not do installation, commissioning or maintenance work.

1. Stop the drive and do the steps in section [Electrical safety precautions \(page 18\)](#) before you start the work.
2. Open the cabinet door.
3. Remove the drive module out of the cabinet as described in section [Replacing the drive module \(frames R10 and R11\) \(page 174\)](#).
4. Open the support legs of the pedestal.
5. Undo the two screws that fasten the fan assembly plate.
6. Tilt the fan assembly plate down.
7. Disconnect the power supply wires of the fans.
8. Remove the fan assembly from the drive module.
9. Undo the fastening screws of the fan(s) and remove the fan(s) from the assembly plate.
10. Install the new fan(s) in reverse order.
11. Reset the fan on-time counter in parameter group 5 of the drive control program.

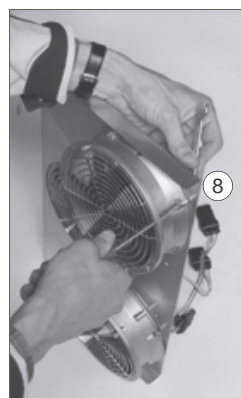

## ■ Replacing the auxiliary cooling fan of the drive module (frames R6...R9)



### WARNING!

Obey the safety instructions of the drive. If you ignore them, injury or death, or damage to the equipment can occur. If you are not a qualified electrical professional, do not do installation, commissioning or maintenance work.

1. Stop the drive and do the steps in section [Electrical safety precautions \(page 18\)](#) before you start the work.
2. Open the cabinet door.
3. Unplug fan power supply wires from the drive.
4. Release the retaining clips.
5. Lift the fan off.
6. Install the new fan in reverse order.

**Note:** Make sure that the arrow on the fan points up.

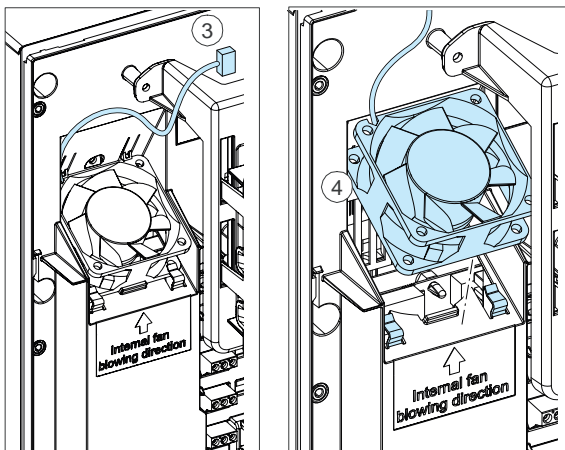

## ■ Replacing the circuit board compartment cooling fans (frames R10 and R11)

---

**WARNING!**

Obey the safety instructions of the drive. If you ignore them, injury or death, or damage to the equipment can occur. If you are not a qualified electrical professional, do not do installation, commissioning or maintenance work.

---

1. Stop the drive and do the steps in section [Electrical safety precautions \(page 18\)](#) before you start the work.
2. Open the cabinet door.
3. Remove the drive module out of the cabinet as described in section [Replacing the drive module \(frames R10 and R11\) \(page 174\)](#).
4. Undo the fastening screw of the fan enclosure.
5. Unplug the power supply cable of the fan.
6. Install the new fan in reverse order.
7. Reset the counter (if used) in parameter *05.04 Fan on-time counter*, in the control program.

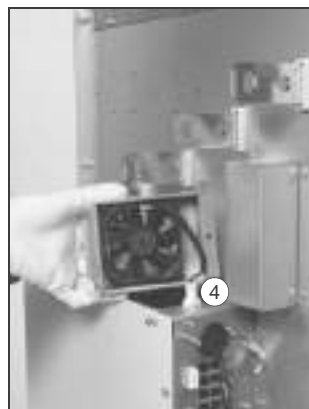

## Replacing the drive module (frames R6...R9)

This replacing procedure requires: preferably two persons, a set of screw drivers with extension bar and a torque wrench, chains for securing the module during the installation. The drawings below show a cabinet of frame size R7. The procedure is the same for the other frame sizes.



**WARNING!**

Obey the safety instructions of the drive. If you ignore them, injury or death, or damage to the equipment can occur. If you are not a qualified electrical professional, do not do installation, commissioning or maintenance work.

---

1. Stop the drive and do the steps in section [Electrical safety precautions \(page 18\)](#) before you start the work.
  2. Open the cabinet door.
  3. To attach the sliding rails:
    - 3 a) Remove the sliding rails (2 pcs) from the left-hand side cabinet frame.
    - 3 b) Undo the four screws from the top horizontal studs.
    - 3 c) Attach the left-hand side sliding rail to the horizontal stud with the removed screws
    - 3 d) Attach the right-hand side sliding rail to the horizontal stud with the removed screws.
- 



**WARNING!**

Check that the stopping screws (3e) at the ends of the studs are in place, so that the drive module cannot slide off the rail.

---



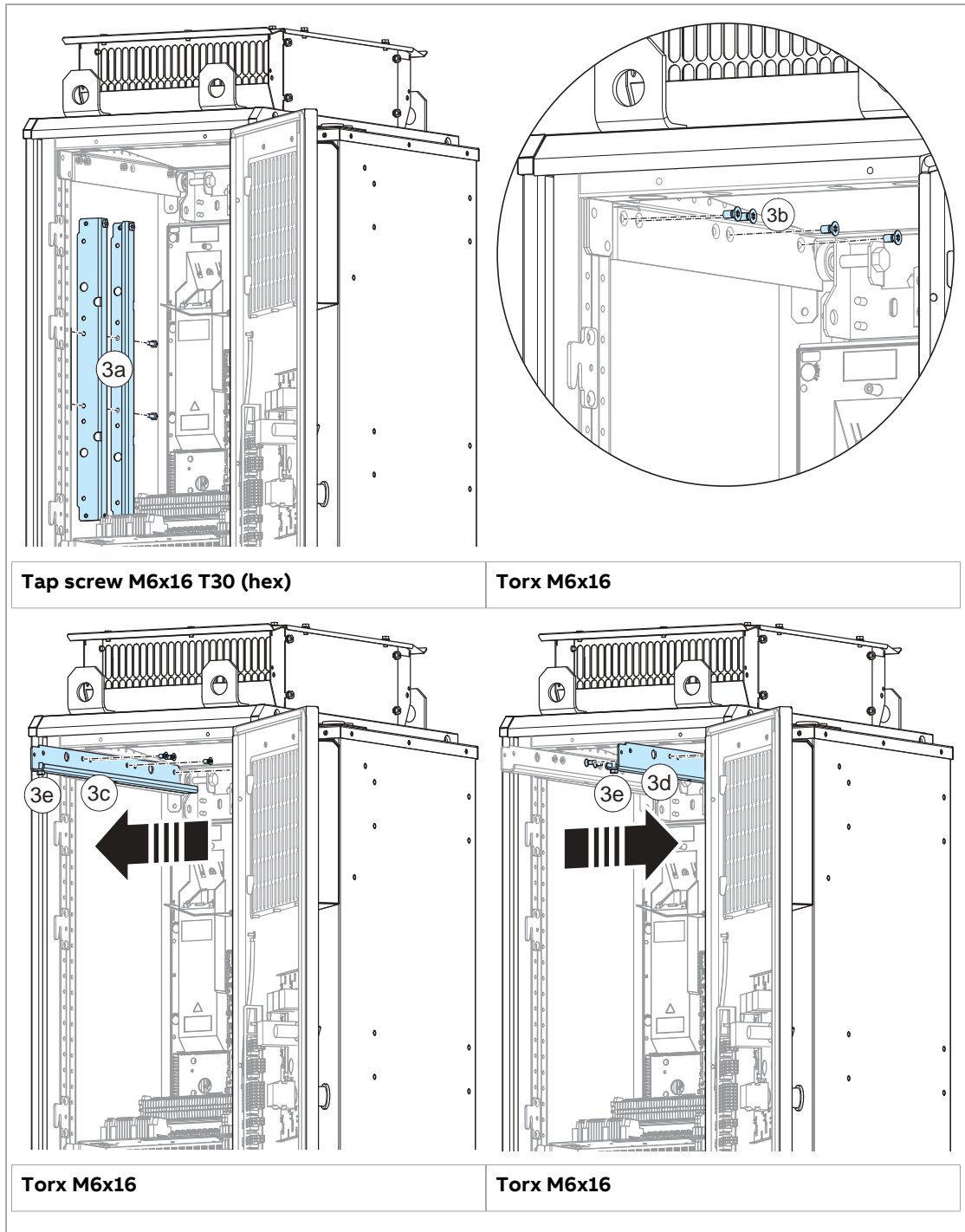

4. Unplug the wires connected to the mounting plate connectors (if present).
5. Remove the mounting plate (four screws).
6. Remove the shroud (two screws).
7. Remove the shroud on the power cable connection terminals.

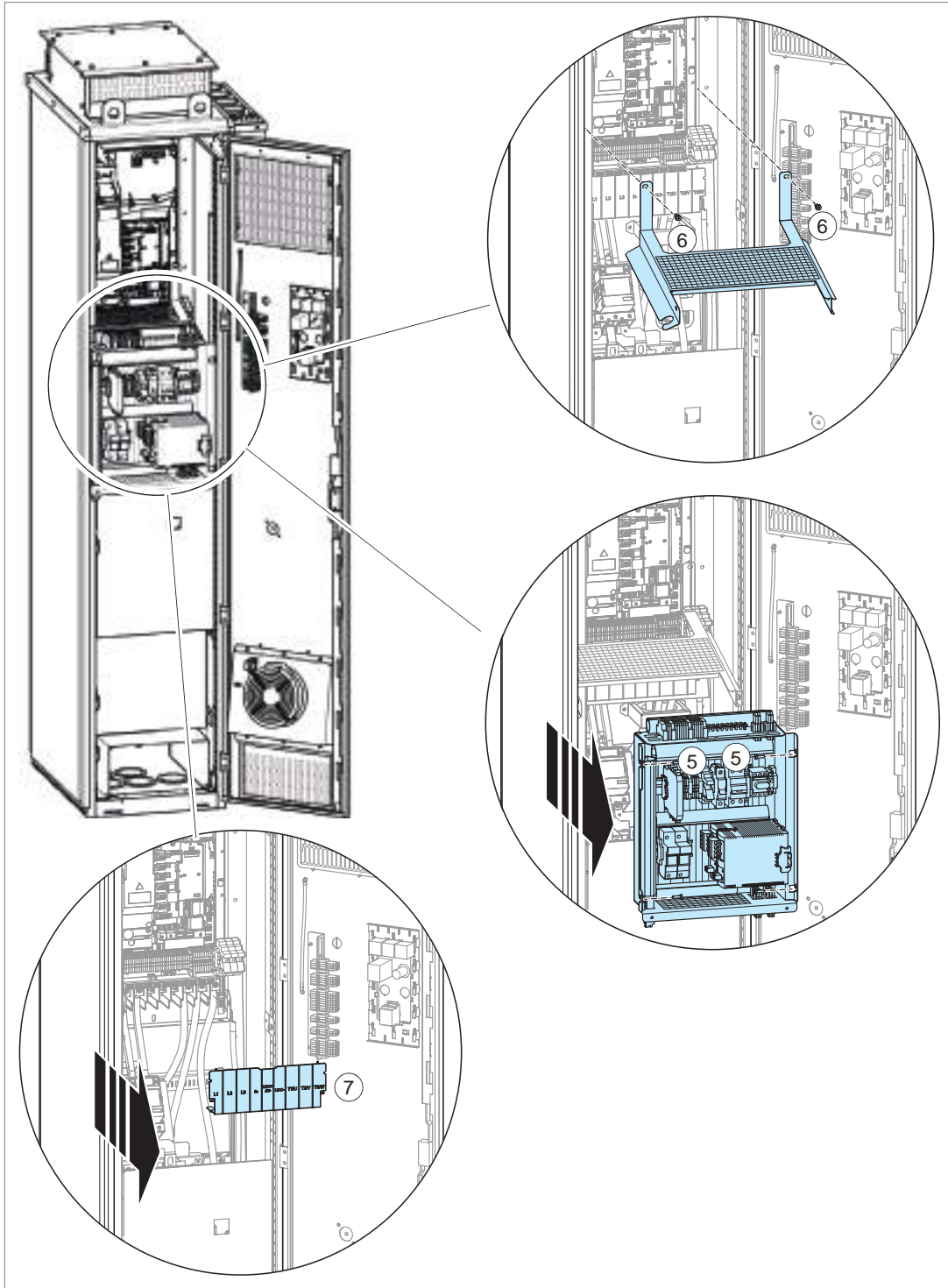

8. Disconnect the option modules from the control unit.
9. For drives with additional I/O terminal block (option +L504), disconnect the upper terminals and remove any fastening. Move the wires aside before you lift the module out. **Note:** Mark the wires for reconnection!

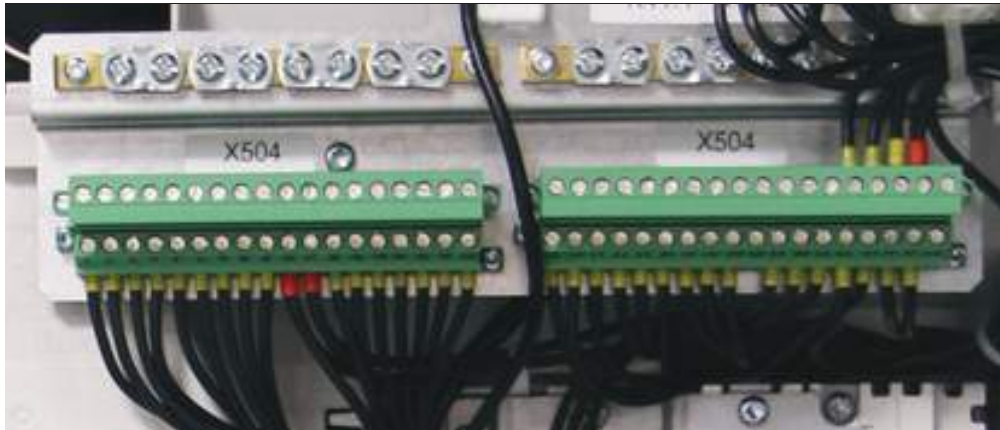

10. For drives without additional I/O terminal block (option +L504), disconnect the customer-installed wires from the control unit. **Note:** Mark the wires for reconnection!
11. For drives with line contactor (option +F250), disconnect the input power cables from the output of the contactor.

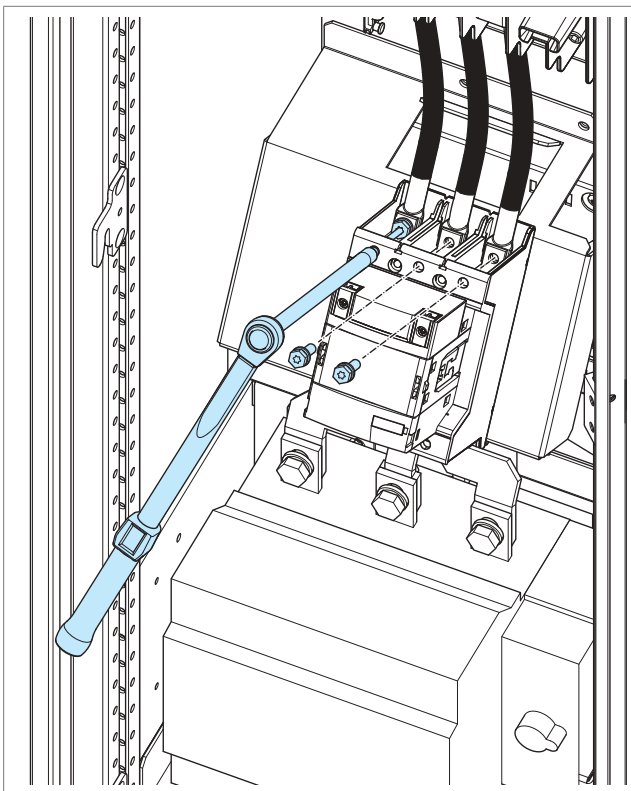

12. Disconnect the input power cable conductors and motor cable conductors from the drive module terminals.
-

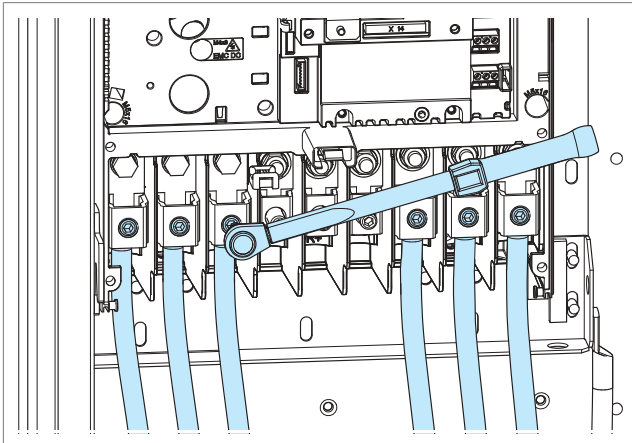

13. Secure the drive module with chains from the lifting eyes.
14. Undo the mounting screws of the flange.
15. Slide the drive module forwards along the sliding bars.
16. Lift the module out of the cabinet with a lifting device.

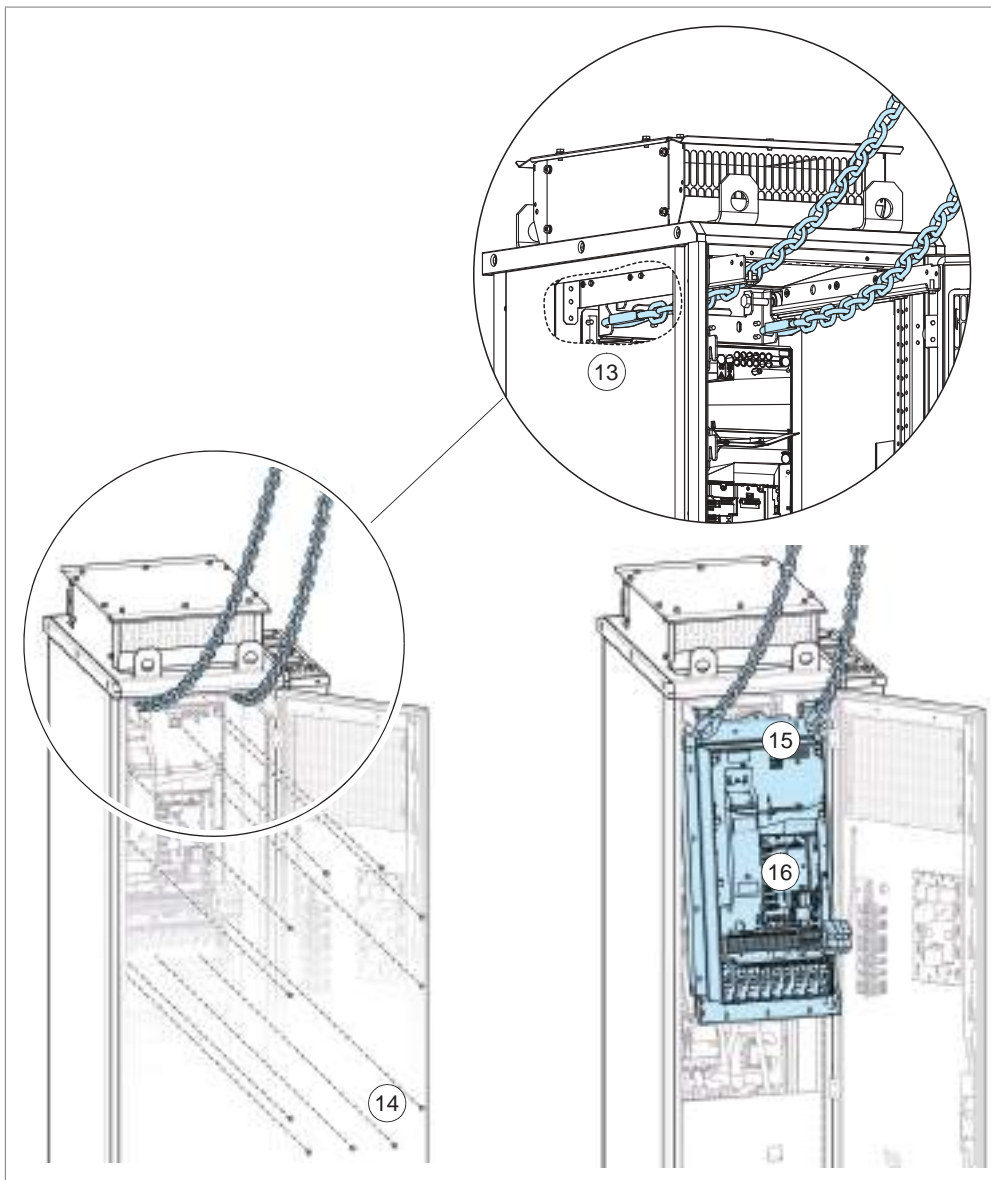

17. Remove the flange.

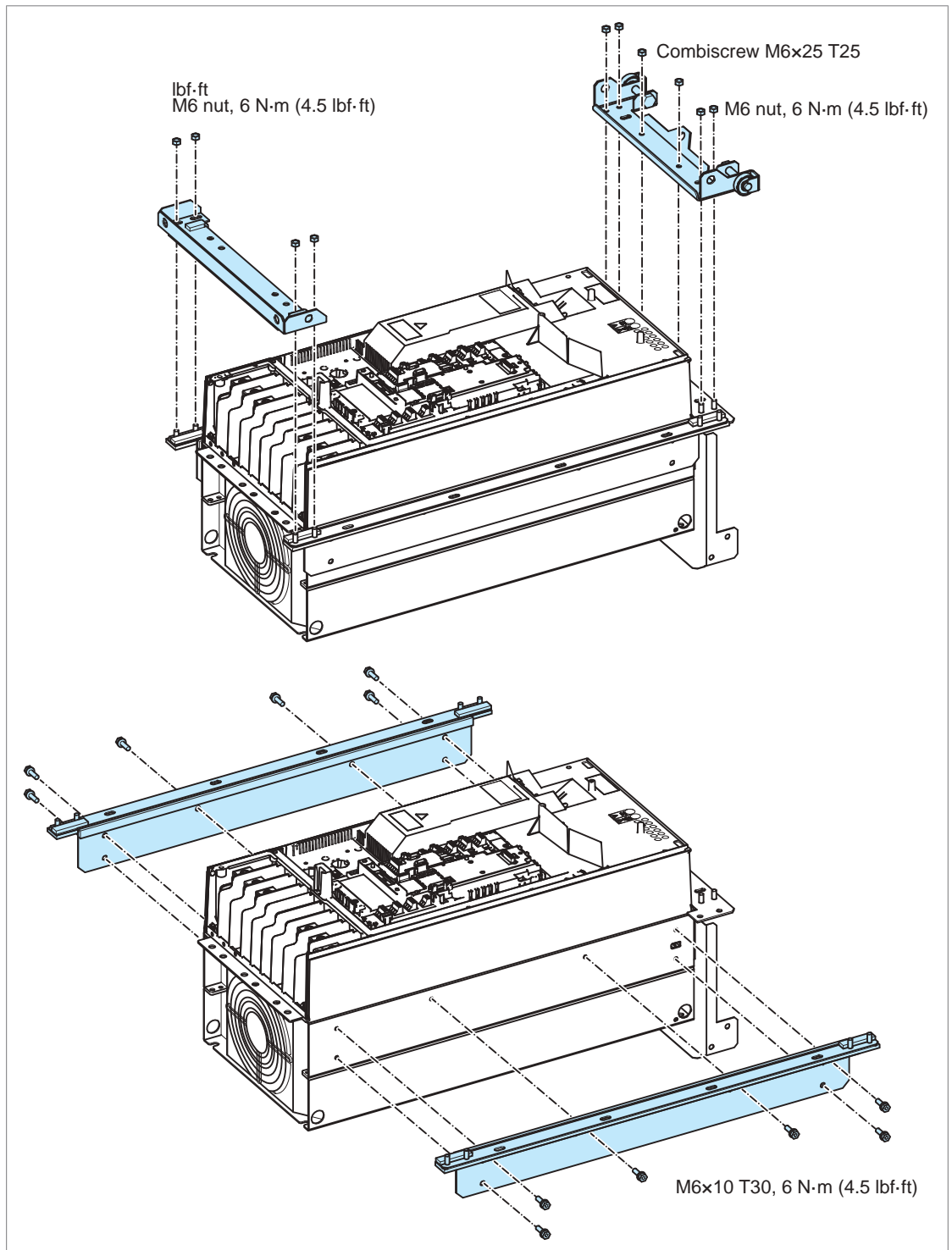

18. Install the new module in reverse order.

## Replacing the drive module (frames R10 and R11)

---



**WARNING!**

Obey the safety instructions of the drive. If you ignore them, injury or death, or damage to the equipment can occur. If you are not a qualified electrical professional, do not do installation, commissioning or maintenance work.

---

This replacing procedure requires: preferably two persons, extraction/installation ramp, a set of screw drivers and a torque wrench with an extension bar of 500 mm (20 in), chains for securing the module during the installation.

The drawings show frame R10. The details in frame R11 are slightly different.

1. Stop the drive and do the steps in section [Electrical safety precautions \(page 18\)](#) before you start the work.
  2. Open the cabinet door.
  3. Remove the shrouds.
  4. Unplug the quick connectors at the top and bottom of the control unit mounting plate.
  5. Disconnect the PE conductor of the auxiliary control voltage transformer.
-

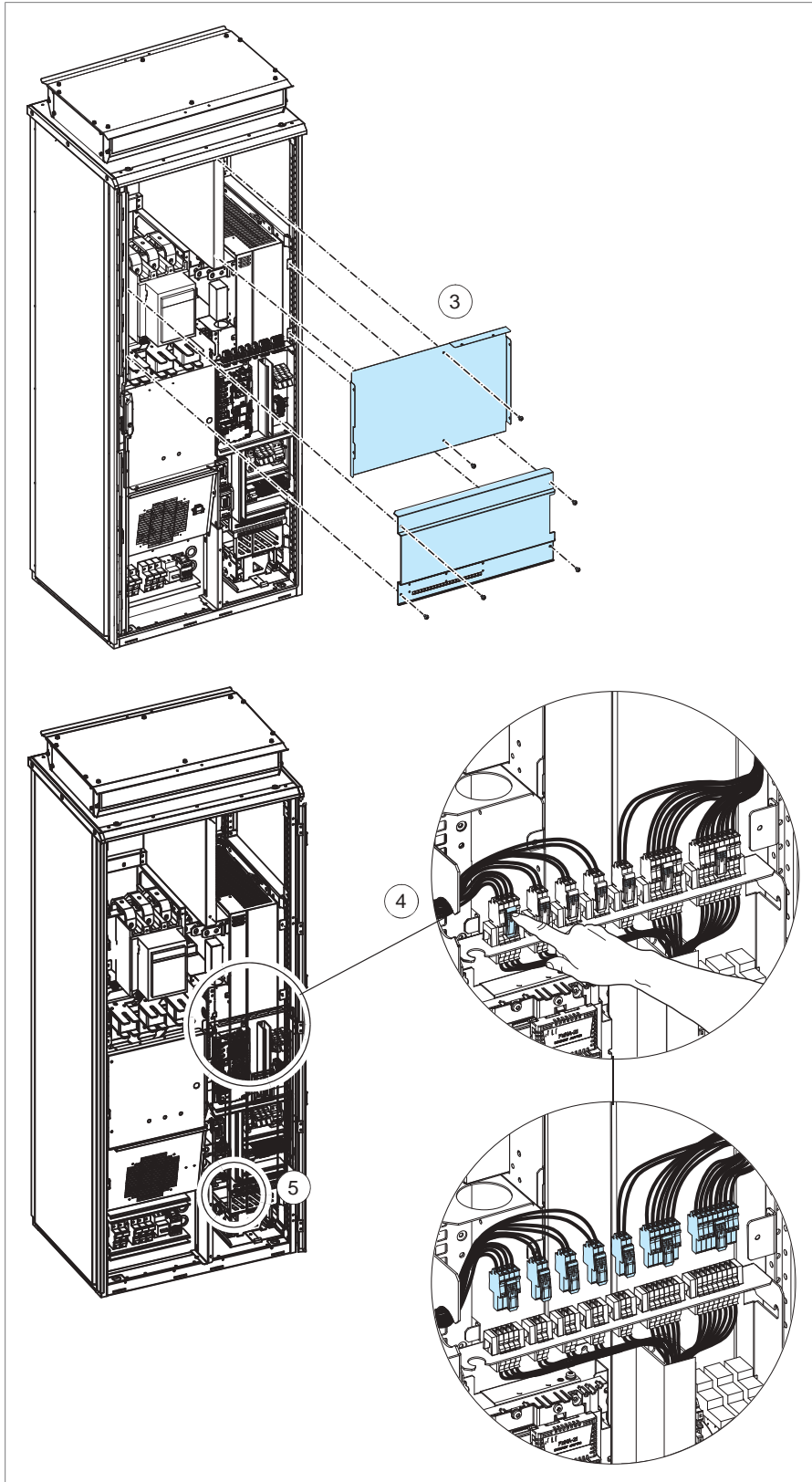

6. Remove the mounting plate.

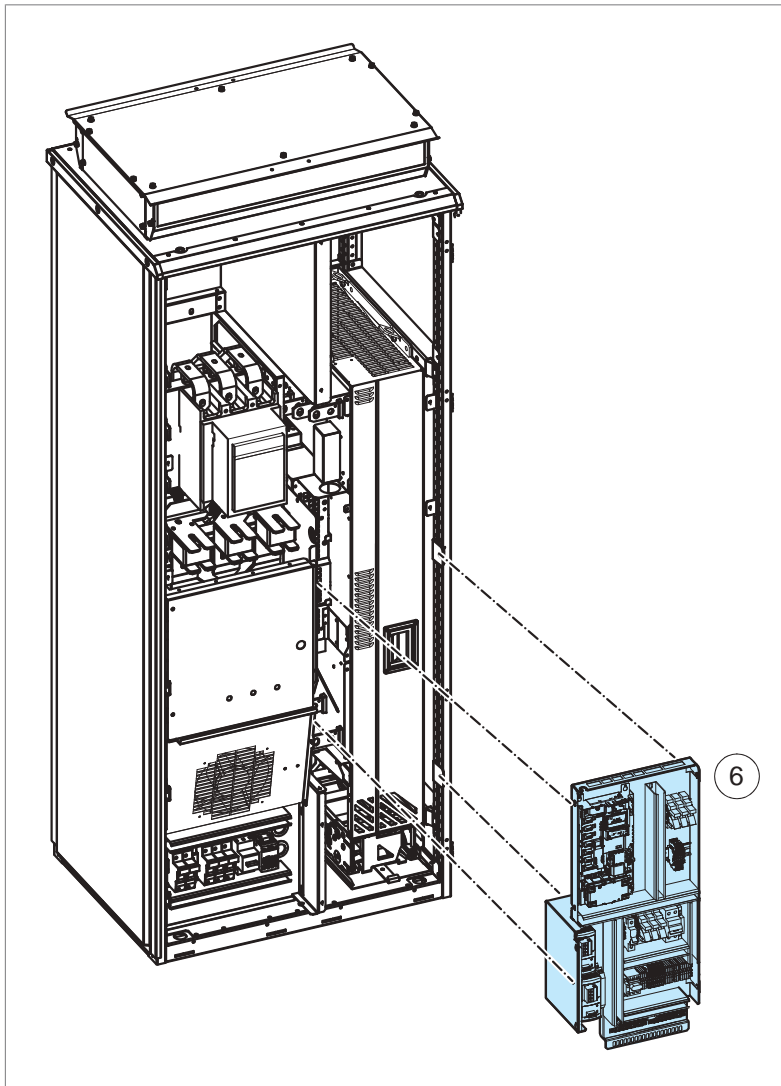



7. Disconnect the drive module input busbars with a torque wrench with an extension bar of 500 mm (20 in). Combi screw M12, 70 N·m (52 lbf·ft).
8. Disconnect the drive module output busbars. M12, 70 N·m (52 lbf·ft).

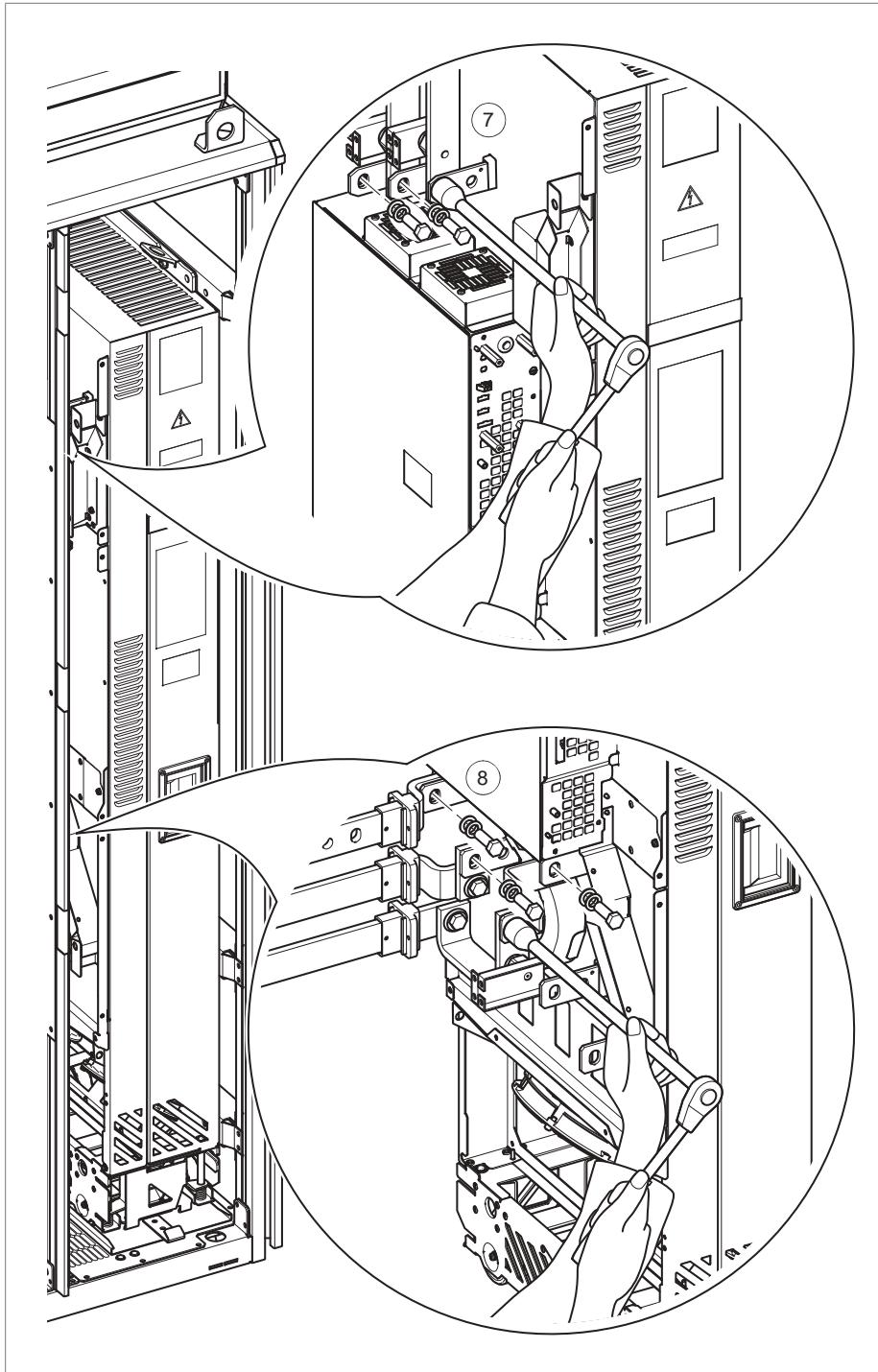

9. Remove the shroud. Undo the screws that attach the drive module to the cabinet at the top and behind the front support legs.

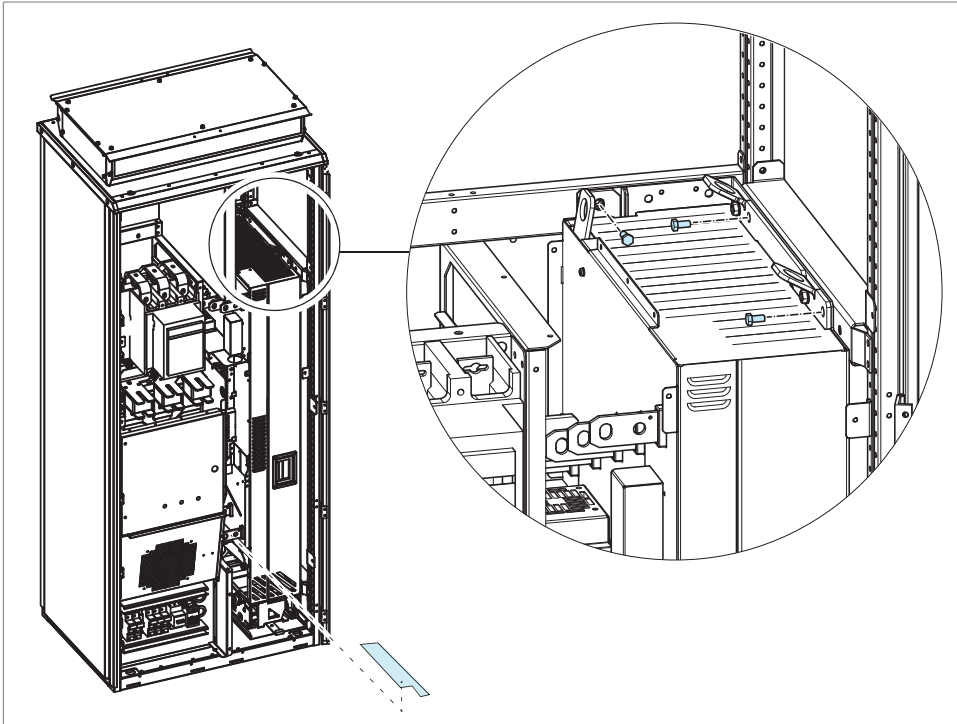

10. Attach the extraction ramp to the cabinet base with two screws.

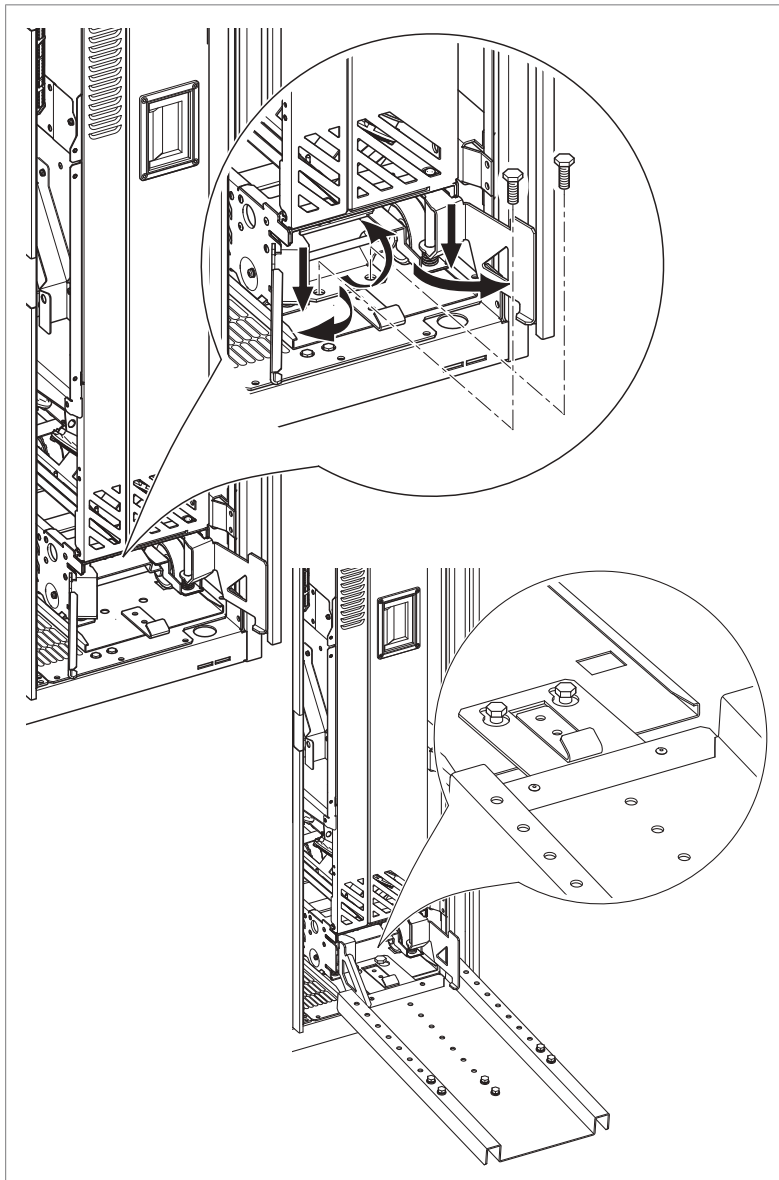

11. Attach the drive module lifting lugs to the cabinet lifting lug with chains.
  12. Pull the drive module carefully out of the cabinet preferably with help from another person.
  13. Install the new module in reverse order.
-

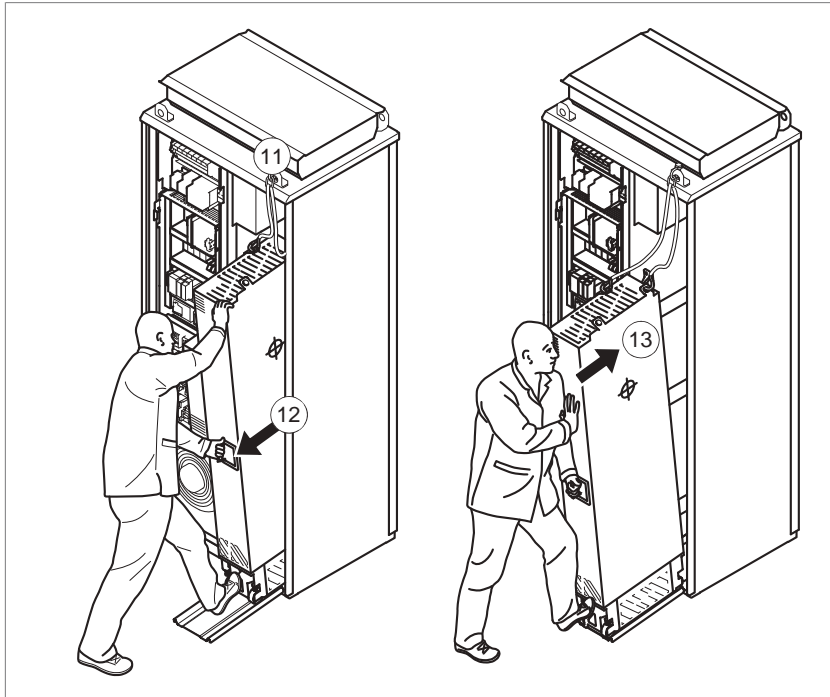

## Replacing the drive module (frames R10 and R11, IP54 / UL Type 12)



### WARNING!

Obey the safety instructions of the drive. If you ignore them, injury or death, or damage to the equipment can occur. If you are not a qualified electrical professional, do not do installation, commissioning or maintenance work.

This replacing procedure requires: preferably two persons, extraction/installation ramp, a set of screw drivers and a torque wrench with an extension bar of 500 mm (20 in), chains for securing the module during the installation.

The drawings show frame R10. The details in frame R11 are slightly different.

1. Stop the drive and do the steps in section [Electrical safety precautions \(page 18\)](#) before you start the work.
2. Open the cabinet door.
3. Remove the shrouds and the additional IP54 fan.
4. Unplug the quick connectors at the top and bottom of the control unit mounting plate.
5. Disconnect the PE conductor of the auxiliary control voltage transformer.

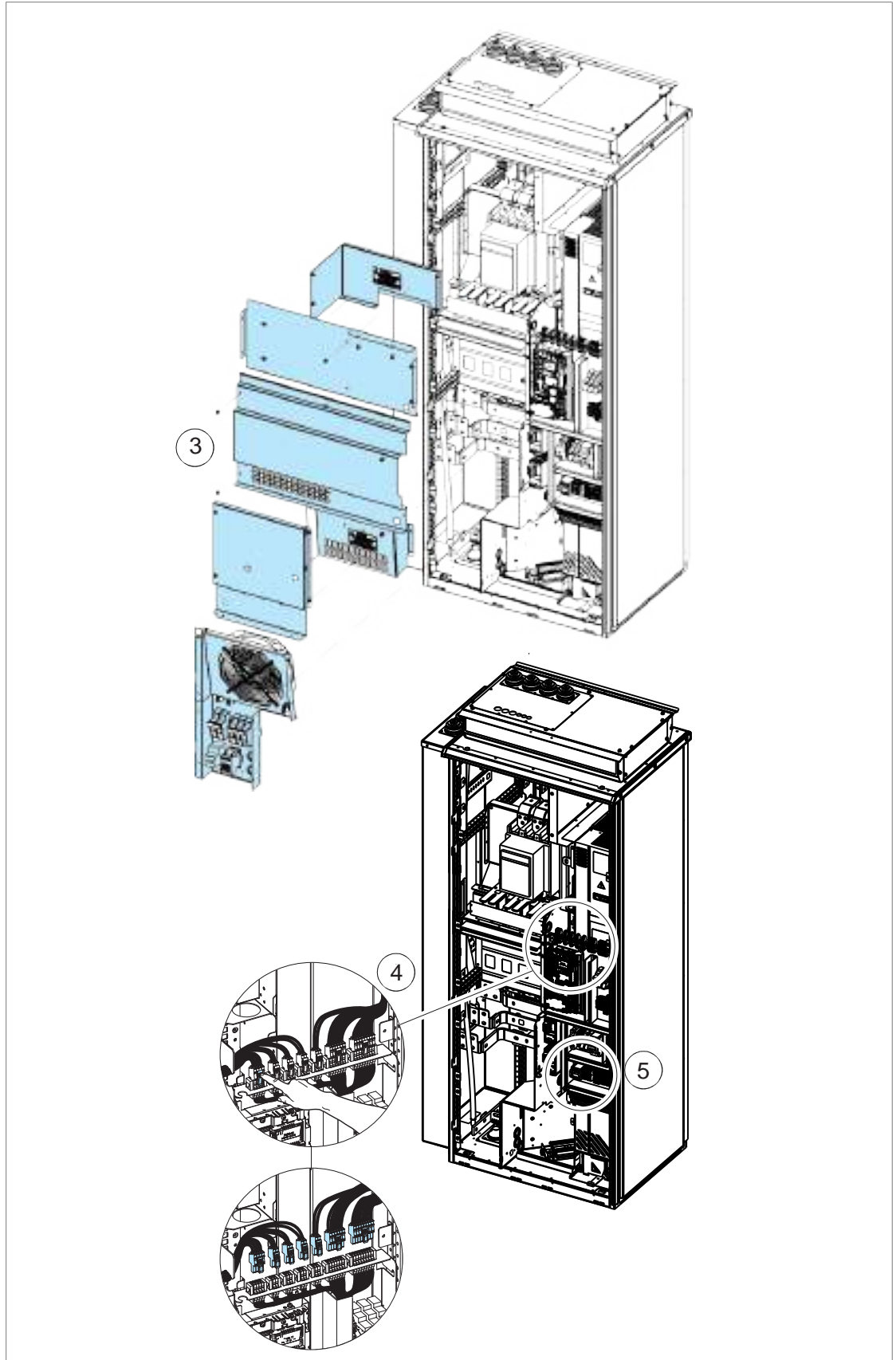

6. Remove the mounting plate.

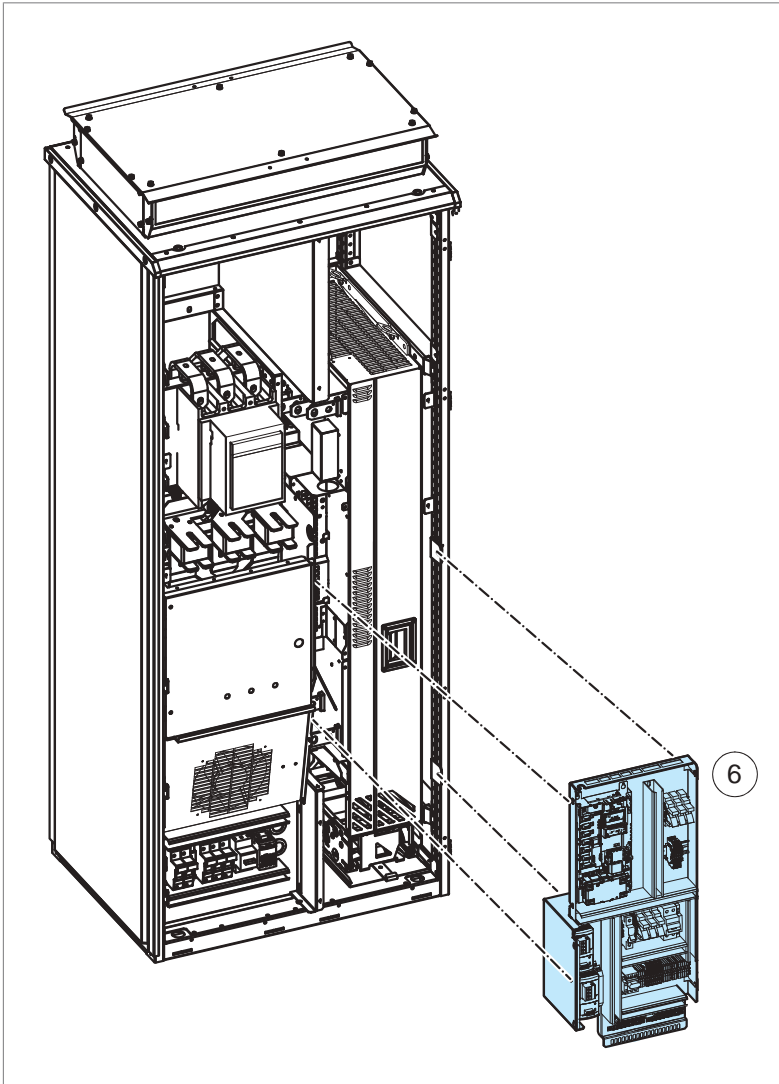

7. Disconnect the drive module input busbars with a torque wrench with an extension bar of 500 mm (20 in). Combi screw M12, 70 N·m (52 lbf·ft).
8. Disconnect the drive module output busbars. M12, 70 N·m (52 lbf·ft).

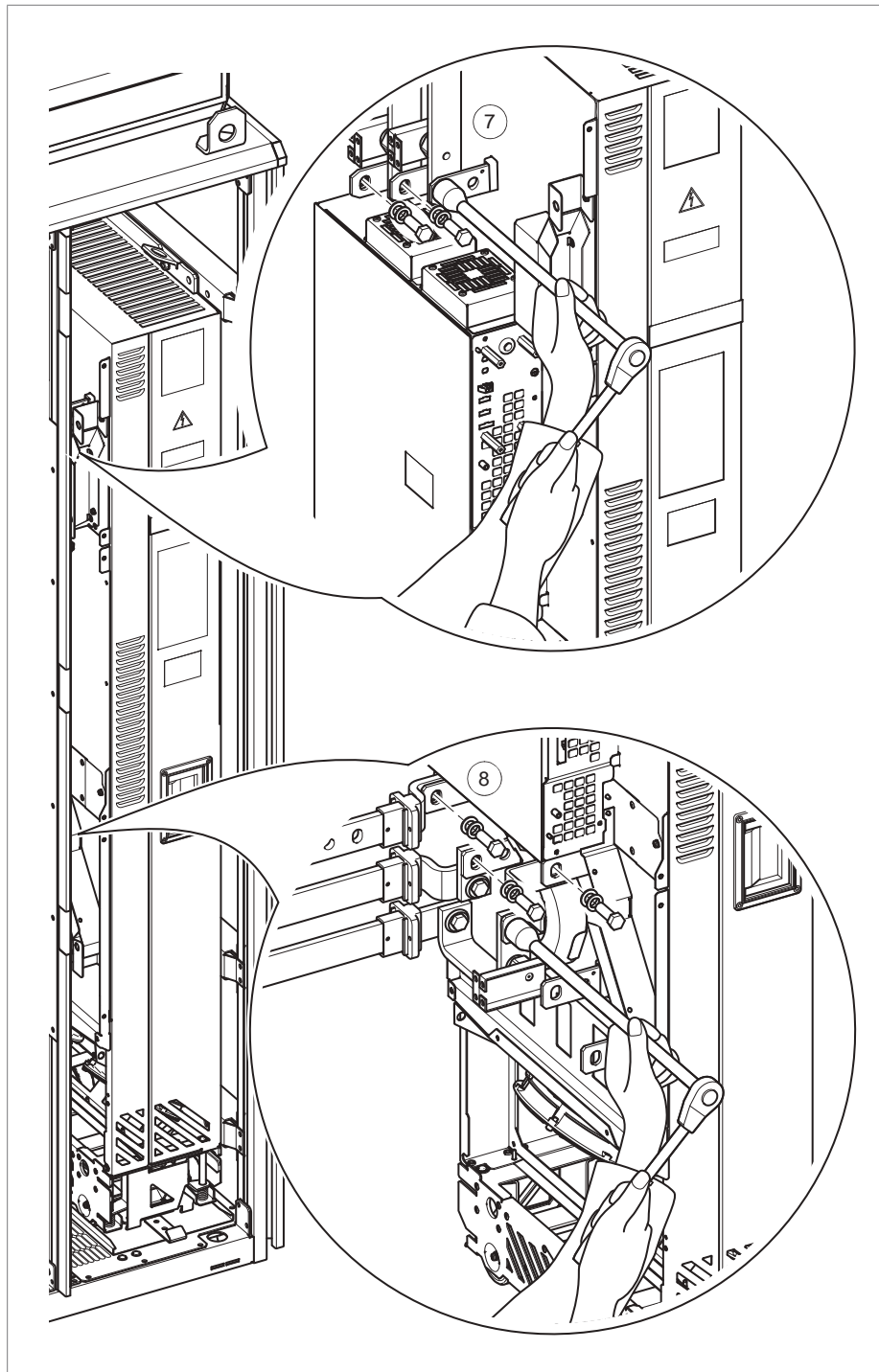

9. Remove the shroud. Undo the screws that attach the drive module to the cabinet at the top and behind the front support legs.

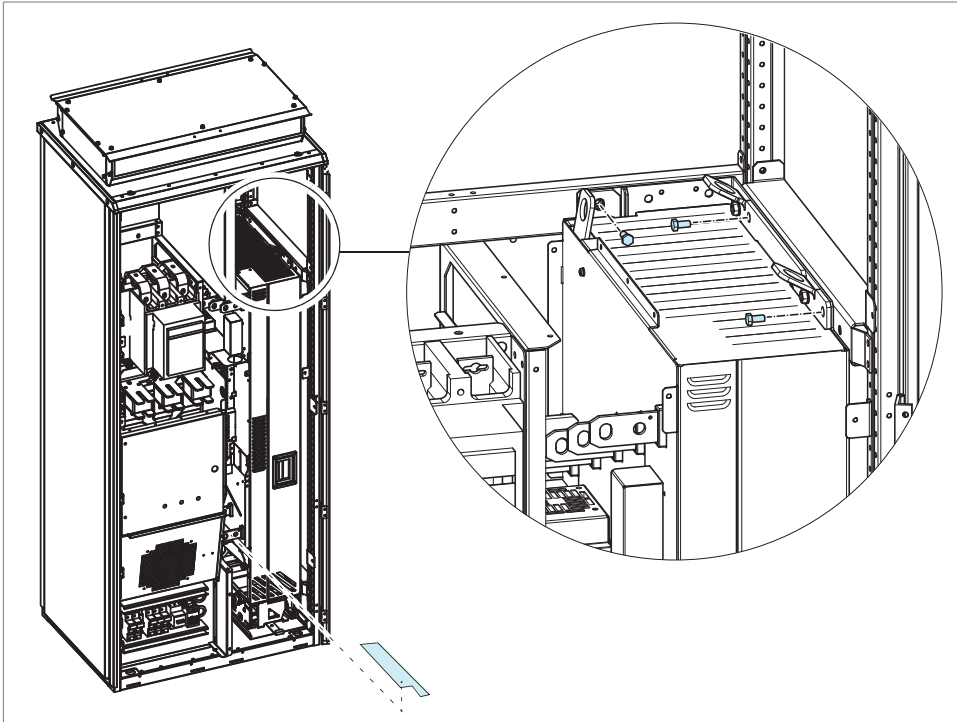



10. Attach the extraction ramp to the cabinet base with two screws.

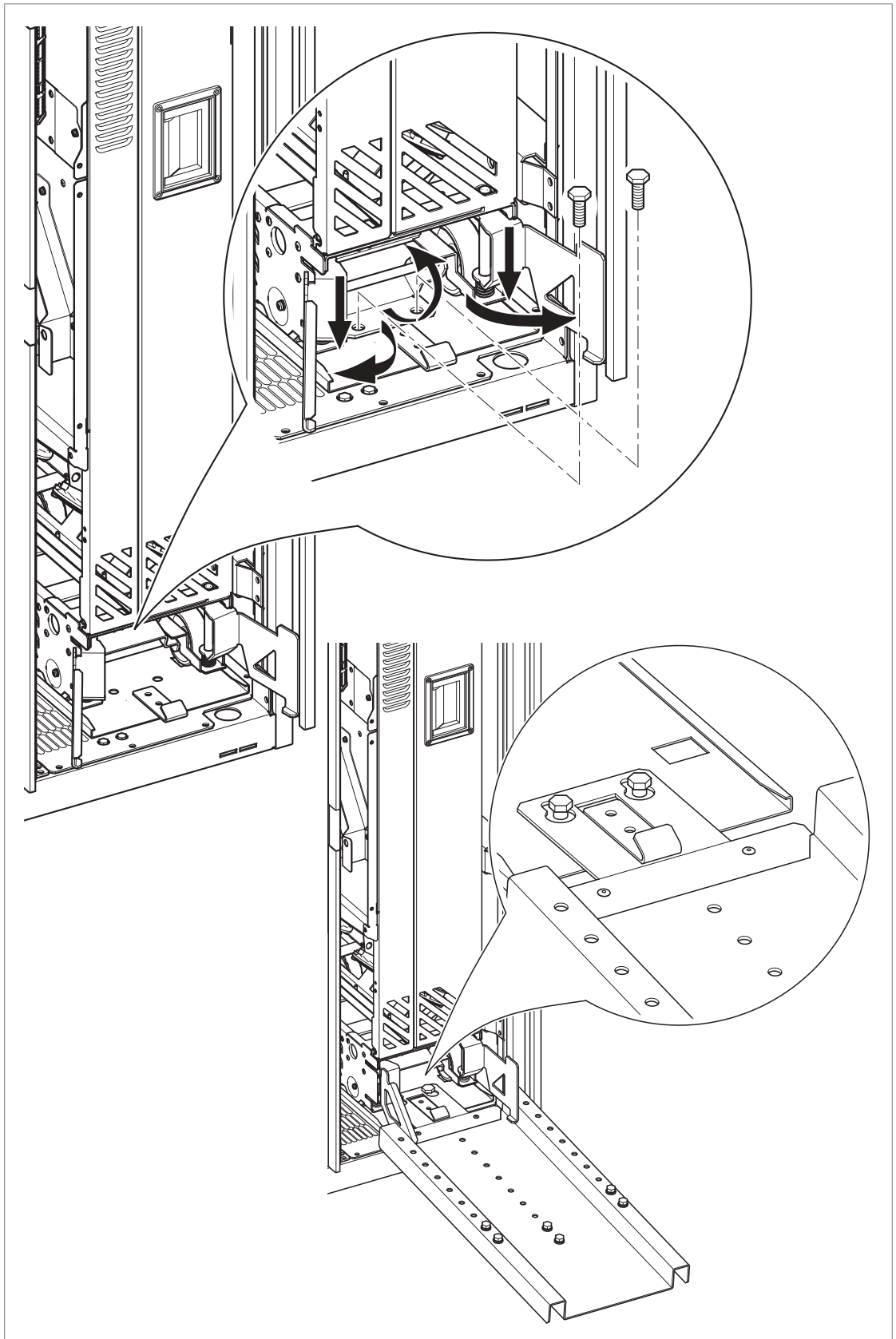

11. Attach the drive module lifting lugs to the cabinet lifting lug with chains.
12. Pull the drive module carefully out of the cabinet preferably with help from another person.
13. Install the new module in reverse order.

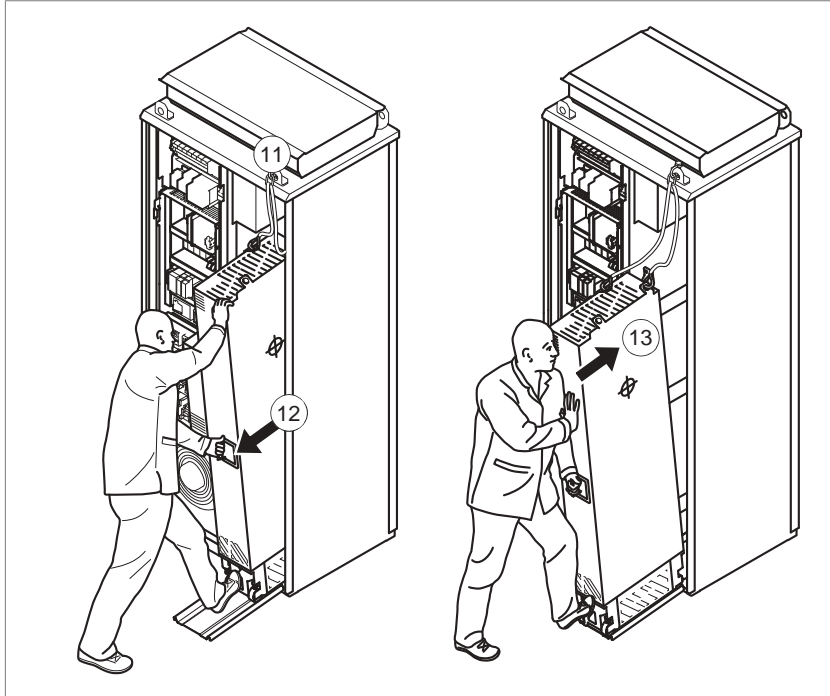

## Capacitors

The intermediate DC circuit of the drive contains several electrolytic capacitors. Operating time, load, and surrounding air temperature have an effect on the life of the capacitors. Capacitor life can be extended by decreasing the surrounding air temperature.

Capacitor failure is usually followed by damage to the unit and an input cable fuse failure, or a fault trip. If you think that any capacitors in the drive have failed, contact ABB.

### ■ Reforming the capacitors

The capacitors must be reformed if the drive has not been powered (either in storage or unused) for a year or more. The manufacturing date is on the type designation label. For information on reforming the capacitors, refer to [Capacitor reforming instructions \(3BFE64059629 \[English\]\)](#).

## Fuses

### ■ Replacing AC fuses (frames R6 and R7)



#### **WARNING!**

Obey the safety instructions of the drive. If you ignore them, injury or death, or damage to the equipment can occur. If you are not a qualified electrical professional, do not do installation, commissioning or maintenance work.

1. Stop the drive and do the steps in section [Electrical safety precautions \(page 18\)](#) before you start the work.
  2. Open the cabinet door.
  3. Remove the shrouding from in front of the switch fuse.
  4. Replace the fuses with the fuse handle which is in the cabinet.
  5. Reinstall the shrouding removed earlier and close the cabinet door.
-

## ■ Replacing AC fuses (frames R10 and R11)



### WARNING!

Obey the safety instructions of the drive. If you ignore them, injury or death, or damage to the equipment can occur. If you are not a qualified electrical professional, do not do installation, commissioning or maintenance work.

1. Stop the drive and do the steps in section [Electrical safety precautions \(page 18\)](#) before you start the work.
2. Open the cabinet door.
3. Remove the shrouding from in front of the fuses.
4. Slacken the nuts of the headless screws of the fuses so that you can slide out the fuse blocks. Make a note of the order of the washers on the screws.
5. Remove the screws, nuts and washers from the old fuses and attach them to the new fuses. Make sure to keep the washers in the original order.

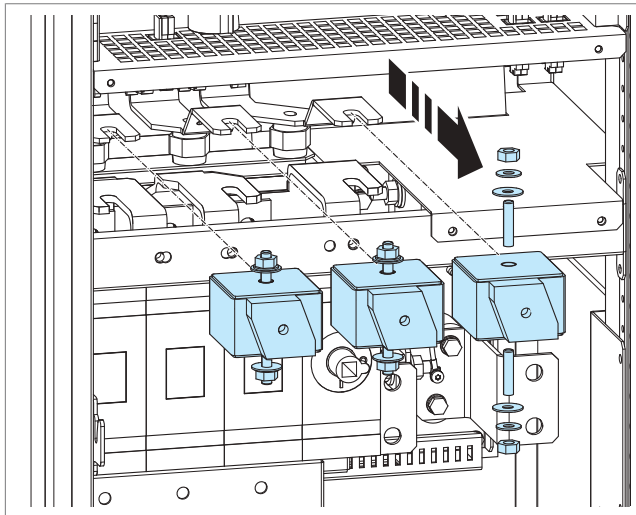

6. Insert the new fuses into their slots in the cabinet.
7. Tighten the screws to torque 5 N·m (3 lbf·ft) maximum.
8. Tighten the nuts to torque as follows:
  - Cooper-Bussmann fuses: 50 N·m (37 lbf·ft) if size 3; 40 N·m (30 lbf·ft) if size 2
  - Mersen (Ferraz-Shawmut): 46 N·m (34 lbf·ft) if size 33; 26 N·m (19 lbf·ft) if size 32
  - Other fuses: Refer to the fuse manufacturer's instructions.
9. Reinstall the shrouding removed earlier and close the cabinet door.

## Control panel

Refer to [ACS-AP-I, -S, -W Assistant control panels user's manual \(3AUA0000085685 \[English\]\)](#).

Refer to [ACS-BP-S basic control panels user's manual \(3AXD50000032527 \[English\]\)](#).

## Functional safety components

The mission time of functional safety components is 20 years which equals the time during which failure rates of electronic components remain constant. This applies to the components of the standard Safe torque off circuit as well as any modules, relays and, typically, any other components that are part of functional safety circuits.

The expiry of mission time terminates the certification and SIL/PL classification of the safety function. The following options exist:

- Renewal of the whole drive and all optional functional safety module(s) and components.
- Renewal of the components in the safety function circuit. In practice, this is economical only with larger drives that have replaceable circuit boards and other components such as relays.

Note that some of the components may already have been renewed earlier, restarting their mission time. The remaining mission time of the whole circuit is however determined by its oldest component.

Contact your local ABB service representative for more information.

---



# 12

## Technical data

### Contents of this chapter

This chapter contains the technical specifications of the drive, for example, the ratings, sizes and technical requirements, provisions for fulfilling the requirements for CE and other markings.

### Electrical ratings

#### ■ IEC ratings

The nominal ratings for the drives with 50 Hz and 60 Hz supply are given below. The symbols are described in section [Definitions \(page 193\)](#).

| IEC RATINGS          |            |              |                 |           |       |       |                |          |                |          |
|----------------------|------------|--------------|-----------------|-----------|-------|-------|----------------|----------|----------------|----------|
| ACH580-07...         | Frame size | Input rating | Output ratings  |           |       |       |                |          |                |          |
|                      |            |              | Nominal ratings |           |       |       | Light-duty use |          | Heavy-duty use |          |
|                      |            |              | $I_1$           | $I_{max}$ | $I_2$ | $P_n$ | $I_{Ld}$       | $P_{Ld}$ | $I_{Hd}$       | $P_{Hd}$ |
| A                    | A          | A            | kW              | A         | kW    | A     | kW             |          |                |          |
| $U_n = 400\text{ V}$ |            |              |                 |           |       |       |                |          |                |          |
| 0145A-4              | R6         | 145          | 178             | 145       | 75    | 138   | 75             | 105      | 55             |          |
| 0169A-4              | R7         | 169          | 247             | 169       | 90    | 161   | 90             | 145      | 75             |          |
| 0206A-4              | R7         | 206          | 287             | 206       | 110   | 196   | 110            | 169      | 90             |          |
| 0246A-4              | R8         | 246          | 350             | 246       | 132   | 234   | 132            | 206      | 110            |          |
| 0293A-4              | R8         | 293          | 418             | 293       | 160   | 278   | 160            | 246*     | 132            |          |
| 0363A-4              | R9         | 363          | 498             | 363       | 200   | 345   | 200            | 293      | 160            |          |
| 0430A-4              | R9         | 430          | 542             | 430       | 250   | 400   | 200            | 363**    | 200            |          |
| 0505A-4              | R10        | 505          | 560             | 505       | 250   | 485   | 250            | 361      | 200            |          |

| IEC RATINGS  |            |              |                 |           |       |       |                |          |                |          |
|--------------|------------|--------------|-----------------|-----------|-------|-------|----------------|----------|----------------|----------|
| ACH580-07... | Frame size | Input rating | Output ratings  |           |       |       |                |          |                |          |
|              |            |              | Nominal ratings |           |       |       | Light-duty use |          | Heavy-duty use |          |
|              |            |              | $I_1$           | $I_{max}$ | $I_2$ | $P_n$ | $I_{Ld}$       | $P_{Ld}$ | $I_{Hd}$       | $P_{Hd}$ |
|              |            |              | A               | A         | A     | kW    | A              | kW       | A              | kW       |
| 0585A-4      | R10        | 585          | 730             | 585       | 315   | 575   | 315            | 429      | 250            |          |
| 0650A-4      | R10        | 650          | 730             | 650       | 355   | 634   | 355            | 477      | 250            |          |
| 0725A-4      | R11        | 725          | 1020            | 725       | 400   | 715   | 400            | 566      | 315            |          |
| 0820A-4      | R11        | 820          | 1020            | 820       | 450   | 810   | 450            | 625      | 355            |          |
| 0880A-4      | R11        | 880          | 1100            | 880       | 500   | 865   | 500            | 725***   | 400            |          |

| IEC RATINGS          |            |              |                 |           |       |       |                |          |                |          |
|----------------------|------------|--------------|-----------------|-----------|-------|-------|----------------|----------|----------------|----------|
| ACH580-07...         | Frame size | Input rating | Output ratings  |           |       |       |                |          |                |          |
|                      |            |              | Nominal ratings |           |       |       | Light-duty use |          | Heavy-duty use |          |
|                      |            |              | $I_1$           | $I_{max}$ | $I_2$ | $P_n$ | $I_{Ld}$       | $P_{Ld}$ | $I_{Hd}$       | $P_{Hd}$ |
|                      |            |              | A               | A         | A     | hp    | A              | hp       | A              | hp       |
| $U_n = 480\text{ V}$ |            |              |                 |           |       |       |                |          |                |          |
| 0145A-4              | R6         | 124          | 178             | 145       | 100   | 124   | 100            | 96       | 75             |          |
| 0169A-4              | R7         | 156          | 247             | 169       | 125   | 156   | 125            | 124      | 100            |          |
| 0206A-4              | R7         | 180          | 287             | 206       | 150   | 180   | 150            | 156      | 125            |          |
| 0246A-4              | R8         | 240          | 350             | 246       | 200   | 240   | 200            | 180      | 150            |          |
| 0293A-4              | R8         | 260          | 418             | 293       | 200   | 260   | 200            | 240      | 150            |          |
| 0363A-4              | R9         | 361          | 542             | 363       | 300   | 361   | 300            | 302      | 250            |          |
| 0430A-4              | R9         | 414          | 542             | 430       | 350   | 414   | 350            | 361      | 300            |          |
| 0505A-4              | R10        | 483          | 560             | 505       | 400   | 483   | 400            | 361      | 300            |          |
| 0585A-4              | R10        | 573          | 730             | 585       | 450   | 573   | 450            | 414      | 350            |          |
| 0650A-4              | R10        | 623          | 730             | 650       | 500   | 623   | 500            | 477      | 400            |          |
| 0725A-4              | R11        | 705          | 850             | 725       | 600   | 705   | 600            | 566      | 450            |          |
| 0820A-4              | R11        | 807          | 1020            | 820       | 700   | 807   | 700            | 625      | 500            |          |
| 0880A-4              | R11        | 807          | 1020            | 880       | 700   | 807   | 700            | 625      | 500            |          |

### ■ UL (NEC) ratings

| UL (NEC) RATINGS     |            |              |                 |           |       |       |                |          |                |          |
|----------------------|------------|--------------|-----------------|-----------|-------|-------|----------------|----------|----------------|----------|
| ACH580-07...         | Frame size | Input rating | Output ratings  |           |       |       |                |          |                |          |
|                      |            |              | Nominal ratings |           |       |       | Light-duty use |          | Heavy-duty use |          |
|                      |            |              | $I_1$           | $I_{max}$ | $I_2$ | $P_n$ | $I_{Ld}$       | $P_{Ld}$ | $I_{Hd}$       | $P_{Hd}$ |
|                      |            |              | A               | A         | A     | hp    | A              | hp       | A              | hp       |
| $U_n = 480\text{ V}$ |            |              |                 |           |       |       |                |          |                |          |
| 0124A-4              | R6         | 124          | 178             | 145       | 100   | 124   | 100            | 96       | 75             |          |
| 0156A-4              | R7         | 156          | 247             | 169       | 125   | 156   | 125            | 124      | 100            |          |
| 0180A-4              | R7         | 180          | 287             | 206       | 150   | 180   | 150            | 156      | 125            |          |
| 0240A-4              | R8         | 240          | 350             | 246       | 200   | 240   | 200            | 180      | 150            |          |
| 0260A-4              | R8         | 260          | 418             | 293       | 200   | 260   | 200            | 240*     | 150            |          |



| UL (NEC) RATINGS |            |              |                 |           |       |                |          |                |          |
|------------------|------------|--------------|-----------------|-----------|-------|----------------|----------|----------------|----------|
| ACH580-07...     | Frame size | Input rating | Output ratings  |           |       |                |          |                |          |
|                  |            |              | Nominal ratings |           |       | Light-duty use |          | Heavy-duty use |          |
|                  |            |              | $I_1$           | $I_{max}$ | $I_2$ | $P_n$          | $I_{Ld}$ | $P_{Ld}$       | $I_{Hd}$ |
| A                | A          | A            | hp              | A         | hp    | A              | hp       |                |          |
| 0361A-4          | R9         | 361          | 542             | 363       | 300   | 361            | 300      | 302            | 250      |
| 0414A-4          | R9         | 414          | 542             | 430       | 350   | 414            | 350      | 361**          | 300      |
| 0505A-4          | R10        | 483          | 560             | 505       | 400   | 483            | 400      | 361            | 300      |
| 0585A-4          | R10        | 573          | 730             | 585       | 450   | 573            | 450      | 414            | 350      |
| 0650A-4          | R10        | 623          | 730             | 650       | 500   | 623            | 500      | 477            | 400      |
| 0725A-4          | R11        | 705          | 850             | 725       | 600   | 705            | 600      | 566            | 450      |
| 0820A-4          | R11        | 807          | 1020            | 820       | 700   | 807            | 700      | 625            | 500      |
| 0880A-4          | R11        | 807          | 1020            | 880       | 700   | 807            | 700      | 625            | 500      |

## ■ Definitions

|           |  |
|-----------|--|
| $U_n$     | Nominal voltage of the drive. For the input voltage range, see section <a href="#">Electrical power network specification (page 232)</a> .   |
| $I_1$     | Nominal rms input current  |
| $I_2$     | Nominal output current (available continuously with no over-loading)   |
| $S_n$     | Apparent power (no overload)   |
| $P_n$     | Typical motor power in no-overload use   |
| $I_{Ld}$  | Continuous rms output current allowing 10% overload for 1 minute every 10 minutes.   |
| $P_{Ld}$  | Typical motor power in light-duty use  |
| $I_{max}$ | Maximum output current. Available for two seconds at start, then as long as allowed by drive temperature.  |
| $I_{Hd}$  | Continuous rms output current allowing 50% overload for 1 minute every 10 minutes.<br>* Continuous rms output current allowing 30% overload for 1 minute every 10 minutes.<br>** Continuous rms output current allowing 25% overload for 1 minute every 10 minutes.<br>*** Continuous rms output current allowing 40% overload for 1 minute every 10 minutes |
| $P_{Hd}$  | Typical motor power in heavy-duty use  |

**Note 1:** The ratings apply at an ambient temperature of 40 °C (104 °F).

**Note 2:** To achieve the rated motor power given in the table, the rated current of the drive must be higher than or equal to the rated motor current.

The DriveSize dimensioning tool available from ABB is recommended for selecting the drive, motor and gear combination.

## Output derating

### ■ Ambient temperature derating

#### Drive types other than -0414A-4 and -0430A-4

In the temperature range +40...50 °C (+104...122 °F), the rated output current is derated by 1% for every added 1 °C (1.8 °F). The output current can be calculated by multiplying the current given in the rating table by the derating factor (*k*):

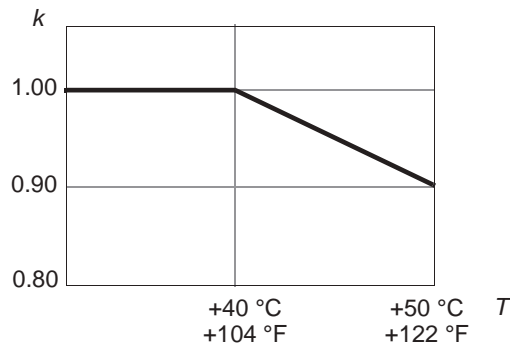

For example:

| Temperature    | Derated current     |                     |
|----------------|---------------------|---------------------|
| 40 °C (104 °F) | $I_{Ld}$            | $I_{Hd}$            |
| 45 °C (113 °F) | $0.95 \cdot I_{Ld}$ | $0.95 \cdot I_{Hd}$ |
| 50 °C (122 °F) | $0.90 \cdot I_{Ld}$ | $0.90 \cdot I_{Hd}$ |

#### Drive types -0414A-4 and -0430A-4

In the temperature range +35...50 °C (+95...122 °F), the rated output current is derated by 1% for every added 1 °C (1.8 °F). The output current can be calculated by multiplying the current given in the rating table by the derating factor (*k*):

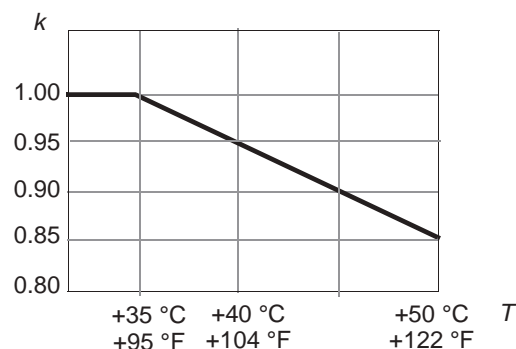

### ■ Altitude derating

At altitudes more than 1000 m (3281 ft) above sea level, the output current derating is 1 percentage point for every added 100 m (328 ft). For example, the derating factor for 1500 m (4921 ft) is 0.95. The maximum permitted installation altitude is given in the technical data.

If the surrounding air temperature is less than +40 °C (104 °F), the derating can be reduced by 1.5 percentage points for every 1 °C (1.8 °F) reduction in temperature. A few altitude derating curves are shown below.

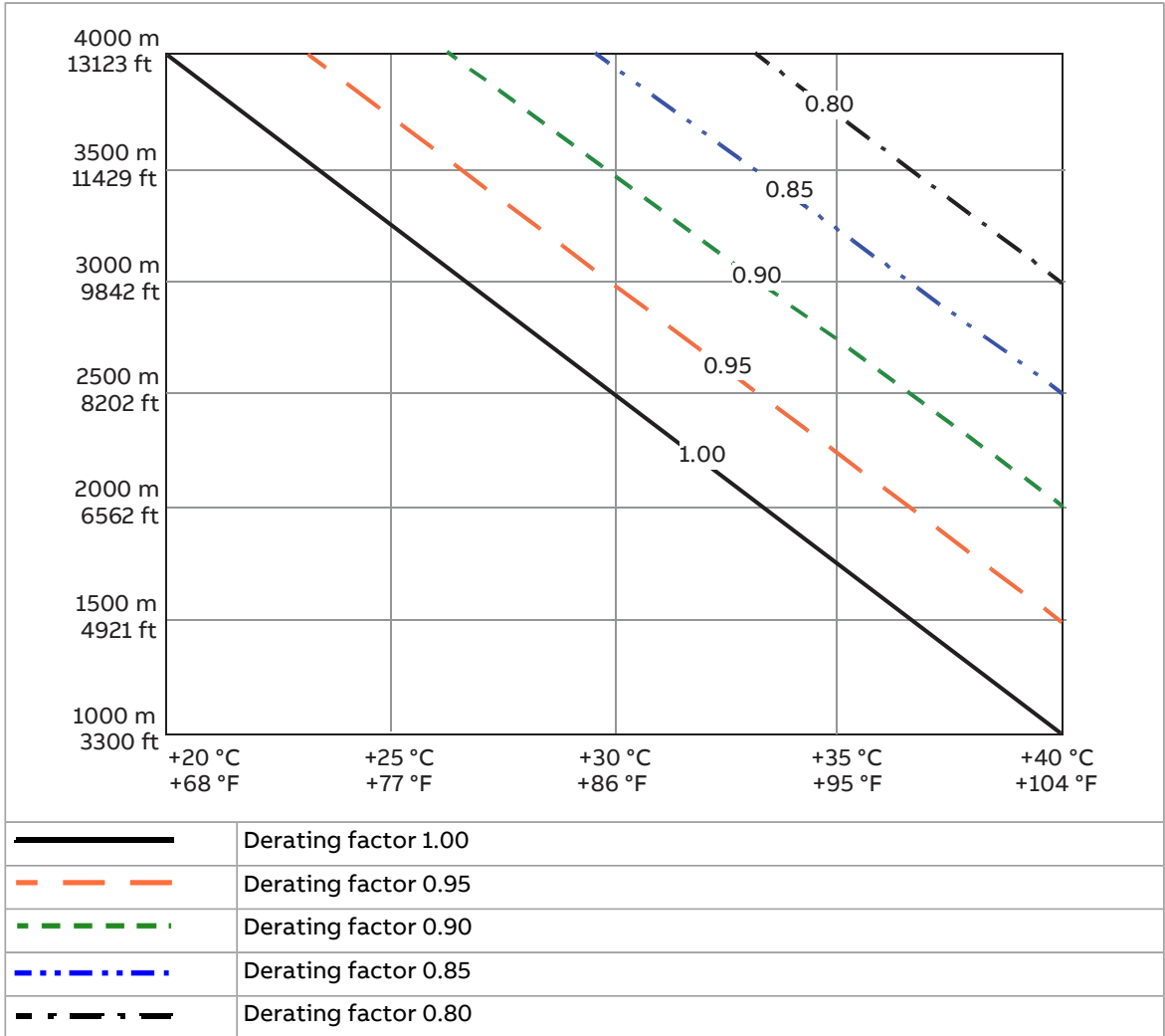

For a more accurate derating, use the DriveSize PC tool.

### ■ Deratings for special settings in the drive control program

If you change the minimum switching frequency with parameter 97.02 Minimum switching frequency, multiply the output current given in [Electrical ratings \(page 191\)](#) by the coefficient value given in this table.

| Frame size | 1.5 kHz | 2 kHz | 4kHz  | 8 kHz |
|------------|---------|-------|-------|-------|
| R6         | 1.00    | 0.97  | 0.84  | 0.66  |
| R7         | 1.00    | 0.98  | 0.89  | 0.71  |
| R8         | 1.00    | 0.96  | 0.82  | 0.61  |
| R9         | 1.00*   | 0.95* | 0.79* | 0.58* |
| R10        | 1.00    | 0.92  | 0.78  | 0.58  |
| R11        | 1.00    | 0.92  | 0.78  | 0.58  |
| R11        | 1.00    | 0.92  | 0.78  | 0.58  |
| R11        | 1.00    | 0.92  | 0.78  | 0.58  |

\* current derating for -0414A-4 and -0430A-4 at 35 °C

**Note:** Changing the value of parameter 97.01 Switching frequency reference does not require derating.

## Fuses (IEC)

The standard drive is equipped with aR fuses listed below.

| ACH580-07...         | Input current (A) | Ultraprapid (aR) fuses (one fuse per phase) |                  |     |                 |               |      |
|----------------------|-------------------|---|------------------|-----|-----------------|---------------|------|
|                      |                   | (A)   | A <sup>2</sup> s | V   | Type (Bussmann) | Type (Mersen) | Size |
| $U_n = 400\text{ V}$ |                   |   |                  |     |                 |               |      |
| 0145A-4              | 145               | 250   | 31000            | 690 | 170M3816D       | J320375C      | 1    |
| 0169A-4              | 169               | 250   | 31000            | 690 | 170M3816D       | J320375C      | 1    |
| 0206A-4              | 206               | 315   | 52000            | 690 | 170M3817D       | N320379C      | 1    |
| 0246A-4              | 246               | 400   | 79000            | 690 | 170M5408        | H300065A      | 2    |
| 0293A-4              | 293               | 500   | 155000           | 690 | 170M5410        | S1046930K     | 2    |
| 0363A-4              | 363               | 630   | 210000           | 690 | 170M6410        | X300078C      | 3    |
| 0430A-4              | 430               | 700   | 300000           | 690 | 170M6411        | Y300079C      | 3    |
| 0505A-4              | 505               | 800   | 465000           | 690 | 170M6412        | W1046956F     | 3    |
| 0585A-4              | 585               | 900   | 670000           | 690 | 170M6413        | X1046957F     | 3    |
| 0650A-4              | 650               | 1000  | 945000           | 690 | 170M6414        | Y1046958F     | 3    |
| 0725A-4              | 725               | 1250  | 1950000          | 690 | 170M6416        | A1046960F     | 3    |
| 0820A-4              | 820               | 1250  | 1950000          | 690 | 170M6416        | A1046960F     | 3    |
| 0880A-4              | 880               | 1400  | 2450000          | 690 | 170M6417        | B1046961F     | 3    |

**Notes:**

- 1 Fuses with a higher current rating than specified must not be used.
- 2 Fuses from other manufacturers can be used if they meet the ratings and the melting curve of the fuse does not exceed the melting curve of the fuse mentioned in the table.

## Fuses (UL)

The drive with option +C129 and option +F289 is equipped with standard fuses listed below for internal circuit protection. The fuses restrict drive damage and prevent damage to adjoining equipment in case of a short-circuit inside the drive. The drive also requires external fuses for branch circuit protection per NEC, see section [Fuses for branch circuit protection \(page 199\)](#).

| ACH580-07...                                  | Input current (A) | Fuse (one fuse per phase) |     |                 |                    |                 |                        |                     |
|---|-------------------|---------------------------|-----|-----------------|--------------------|-----------------|------------------------|---------------------|
|   |                   | A                         | V   | Type (Bussmann) | Type (Mersen)      | UL class / Size | Type with option +F289 | Size (option +F289) |
| $U_n = 480 \text{ V} - \text{UL (NEC) types}$ |                   |                           |     |                 |                    |                 |                        |                     |
| 0124A-4                                       | 124               | 250                       | 600 | DFJ-250         | B235889A (HSJ 250) | J               | 170M3416 / P300002C    | 1                   |
| 0156A-4                                       | 156               | 300                       | 600 | DFJ-300         | C235890A (HSJ 300) | J               | 170M3416 / P300002C    | 1                   |
| 0180A-4                                       | 180               | 300                       | 600 | DFJ-300         | C235890A (HSJ 300) | J               | 170M4410 / G1046920K   | 1                   |
| 0240A-4                                       | 240               | 400                       | 690 | 170M5408        | H300065A           | 2               | 170M4410 / H300065A    | 2                   |
| 0260A-4                                       | 260               | 500                       | 690 | 170M5410        | S1046930K          | 2               | 170M5408 / S1046930K   | 2                   |
| 0361A-4                                       | 361               | 630                       | 690 | 170M6410        | X300078C           | 3               | 170M5410 / X300078C    | 3                   |
| 0414A-4                                       | 414               | 700                       | 690 | 170M6411        | Y300079C           | 3               | 170M6411 / Y300079C    | 3                   |
| 0505A-4                                       | 483               | 800                       | 690 | 170M6412        | W1046956F          | 3               | 170M6412 / W1046956F   | 3                   |
| 0585A-4                                       | 573               | 900                       | 690 | 170M6413        | X1046957F          | 3               | 170M6413 / X1046957F   | 3                   |
| 0650A-4                                       | 623               | 1000                      | 690 | 170M6414        | Y1046958F          | 3               | 170M6414 / Y1046958F   | 3                   |
| 0725A-4                                       | 705               | 1250                      | 690 | 170M6416        | A1046960F          | 3               | 170M6416 / A1046960F   | 3                   |
| 0820A-4                                       | 807               | 1250                      | 690 | 170M6416        | A1046960F          | 3               | 170M6416 / A1046960F   | 3                   |
| 0880A-4                                       | 807               | 1400                      | 690 | 170M6417        | B1046961F          | 3               | 170M6417 / B1046961F   | 3                   |

## Fuses for branch circuit protection

The drive is suitable for use on a circuit capable of delivering not more than 100,000 rms symmetrical amperes at 480 V maximum when the input cable is protected with UL class T or L fuses. The fuses for branch circuit protection per NEC must be selected according to the table below. Obey local regulations.

| ACH580-07...                                 | Input current<br>A | Fuse (one fuse per phase) |     |              |          |          |
|--|--------------------|---------------------------|-----|--------------|----------|----------|
|  |                    | A                         | V   | Manufacturer | Type     | UL class |
| $U_n = 480\text{ V} - \text{UL (NEC) types}$ |                    |                           |     |              |          |          |
| 0124A-4                                      | 124                | 200                       | 600 | Bussmann     | JJS-200  | T        |
| 0156A-4                                      | 156                | 225                       | 600 | Bussmann     | JJS-225  | T        |
| 0180A-4                                      | 180                | 300                       | 600 | Bussmann     | JJS-300  | T        |
| 0240A-4                                      | 240                | 350                       | 600 | Bussmann     | JJS-350  | T        |
| 0260A-4                                      | 260                | 400                       | 600 | Bussmann     | JJS-400  | T        |
| 0361A-4                                      | 361                | 500                       | 600 | Bussmann     | JJS-500  | T        |
| 0414A-4                                      | 414                | 600                       | 600 | Bussmann     | JJS-600  | T        |
| 0505A-4                                      | 483                | 600                       | 600 | Bussmann     | JJS-600  | T        |
| 0585A-4                                      | 573                | 800                       | 600 | Ferraz       | A4BY800  | L        |
| 0650A-4                                      | 623                | 800                       | 600 | Ferraz       | A4BY800  | L        |
| 0725A-4                                      | 705                | 800                       | 600 | Ferraz       | A4BY800  | L        |
| 0820A-4                                      | 807                | 900                       | 600 | Ferraz       | A4BY900  | L        |
| 0880A-4                                      | 807                | 1000                      | 600 | Ferraz       | A4BY1000 | L        |

## Dimensions and weights

| Frame size         | Height | Width <sup>1)</sup> | Depth | Weight |
|--------------------|--------|---------------------|-------|--------|
|                    | mm     | mm                  | mm    | kg     |
| R6                 | 2145   | 430                 | 673   | 210    |
| R7                 | 2145   | 430                 | 673   | 220    |
| R8                 | 2145   | 530                 | 673   | 255    |
| R9                 | 2145   | 530                 | 673   | 275    |
| R10                | 2145   | 830                 | 698   | 410    |
| R10 (option +B055) | 2315   | 830                 | 698   | 410    |
| R11                | 2145   | 830                 | 698   | 440    |
| R11 (option +B055) | 2315   | 830                 | 698   | 440    |

<sup>1)</sup> For frames R6...R9 additional width with options +H351 and +H353: 128 mm.  
For frames R10 and R11 additional width with option +H353: 153 mm.

| ACH580-07...       | Height | Width <sup>1)</sup> | Depth | Weight |
|--------------------|--------|---------------------|-------|--------|
|                    | in.    | in.                 | in.   | lb     |
| R6                 | 84.43  | 16.93               | 26.50 | 463    |
| R7                 | 84.43  | 16.93               | 26.50 | 485    |
| R8                 | 84.43  | 20.87               | 26.50 | 562    |
| R9                 | 84.43  | 20.87               | 26.50 | 606    |
| R10                | 84.43  | 32.68               | 27.48 | 904    |
| R10 (option +B055) | 91.14  | 32.68               | 27.48 | 904    |
| R11                | 84.43  | 32.68               | 27.48 | 970    |
| R11 (option +B055) | 91.14  | 32.68               | 27.48 | 970    |

<sup>1)</sup> For frames R6...R9 extra width with options +H351 and +H353: 5.04 in.  
For frames R10 and R11 width with option +H353: 6.02 in.



## Free space requirements

Free space requirements for cooling are given below.

| Front |      | Side |     | Above * |       |
|-------|------|------|-----|---------|-------|
| mm    | in.  | mm   | in. | mm      | in.   |
| 150   | 5.91 | -    | -   | 400     | 15.75 |

\* measured from the base plate of the cabinet top.

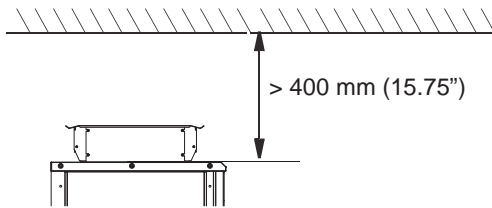

Free space for door opening:

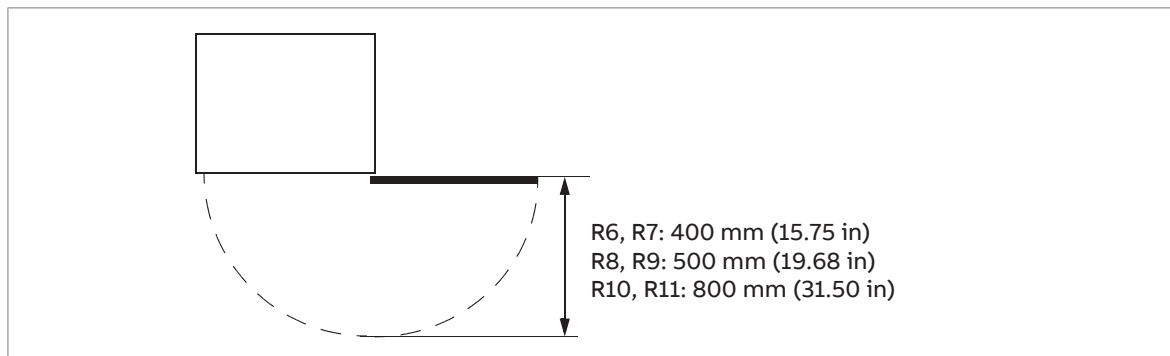

## Maximum allowed plinth height for the extraction/installation ramp

The maximum plinth height for the extraction/installation ramp delivered with the drive is 50 mm (1.97 in).

## Typical power cables

The table below gives typical copper and aluminum cable types with concentric copper shield for the drives with nominal current. For the cable sizes accepted by the drive cabinet cable entries and connection terminals, see [Terminal and entry data for the power cables \(page 204\)](#).

| ACH580-07...         | Frame size | IEC <sup>1)</sup> |                 | US <sup>2)</sup>    |
|----------------------|------------|-------------------|-----------------|---------------------|
|                      |            | Cu cable type     | Al cable type   | Cu cable type       |
|                      |            | mm <sup>2</sup>   | mm <sup>2</sup> | AWG/kcmil per phase |
| $U_n = 400\text{ V}$ |            |                   |                 |                     |
| 0145A-4              | R6         | 3×95              | 3×120           | 3/0                 |
| 0169A-4              | R7         | 3×120             | 3×150           | 250 MCM             |
| 0206A-4              | R7         | 3×150             | 3×240           | 300 MCM             |
| 0246A-4              | R8         | 2×(3×70)          | 2×(3×95)        | 2×2/0               |

| ACH580-07...                                | Frame size | IEC 1)          |                 | US 2)                  |
|---|------------|-----------------|-----------------|------------------------|
|   |            | Cu cable type   | Al cable type   | Cu cable type          |
|   |            | mm <sup>2</sup> | mm <sup>2</sup> | AWG/kcmil per phase    |
| 0293A-4                                     | R8         | 2×(3×95)        | 2×(3×120)       | 2×3/0                  |
| 0363A-4                                     | R9         | 2×(3×120)       | 2×(3×185)       | 2×250 MCM              |
| 0430A-4                                     | R9         | 2×(3×150)       | 2×(3×240)       | 2×300 MCM              |
| 0505A-4                                     | R10        | 3×(3×95)        | 3×(3×150)       | 2×500 MCM or 3×250 MCM |
| 0585A-4                                     | R10        | 3×(3×120)       | 4×(3×150)       | 3×300 MCM              |
| 0650A-4                                     | R10        | 3×(3×150)       | 4×(3×150)       | 3×300 MCM              |
| 0725A-4                                     | R11        | 3×(3×185)       | 4×(3×185)       | 3×500 MCM or 4×300 MCM |
| 0820A-4                                     | R11        | 3×(3×240)       | 4×(3×240)       | 3×600 MCM or 4×400 MCM |
| 0880A-4                                     | R11        | 3×(3×240)       | 4×(3×240)       | 3×600 MCM or 4×400 MCM |
| <i>U<sub>n</sub></i> = 480 V UL (NEC) types |            |                 |                 |                        |
| 0124A-4                                     | R6         | 3×95            | 3×120           | 3/0                    |
| 0156A-4                                     | R7         | 3×120           | 3×150           | 250 MCM                |
| 0180A-4                                     | R7         | 3×150           | 3×240           | 300 MCM                |
| 0240A-4                                     | R8         | 2×(3×70)        | 2×(3×95)        | 2×2/0                  |
| 0260A-4                                     | R8         | 2×(3×95)        | 2×(3×120)       | 2×3/0                  |
| 0361A-4                                     | R9         | 2×(3×120)       | 2×(3×185)       | 2×250 MCM              |
| 0414A-4                                     | R9         | 2×(3×150)       | 2×(3×240)       | 2×300 MCM              |
| 0505A-4                                     | R10        | 3×(3×95)        | 3×(3×150)       | 2×500/3×250 MCM        |
| 0585A-4                                     | R10        | 3×(3×120)       | 4×(3×150)       | 3×300 MCM              |
| 0650A-4                                     | R10        | 3×(3×150)       | 4×(3×150)       | 3×300 MCM              |
| 0725A-4                                     | R11        | 3×(3×185)       | 4×(3×185)       | 3×500/4×300 MCM        |
| 0820A-4                                     | R11        | 3×(3×240)       | 4×(3×240)       | 3×600/4×400 MCM        |
| 0880A-4                                     | R11        | 3×(3×240)       | 4×(3×240)       | 3×600/4×400 MCM        |

1) The cable selection is based on max. 9 cables laid on a cable ladder side by side, three ladder type trays one on top of the other, ambient temperature 30 °C (86 °F) PVC insulation, surface temperature 70 °C (158 °F) (EN 60204-1 and IEC 60364-5-52). For other conditions, select the cables according to local safety regulations, appropriate input voltage and the load current of the drive.

2) The cable selection is based on NEC Table 310-16 for copper wires, 75 °C (167 °F) wire insulation at 40 °C (104 °F) ambient temperature. Not more than three current-carrying conductors in raceway or cable or earth (directly buried). For other conditions, dimension the cables according to local safety regulations, appropriate input voltage and the load current of the drive.

**Temperature:** For IEC, select a cable rated for at least 70 °C maximum permissible temperature of conductor in continuous use. For North America, power cables must be rated for 75 °C (167 °F) or higher.

**Voltage:** 600 V AC cable is accepted for up to 500 V AC.

## Losses, cooling data and noise

| ACH580-07...                           | Air flow               |     |                   |     | Heat dissipation | Noise |
|--|------------------------|-----|-------------------|-----|------------------|-------|
|  | IP21, IP42 (UL Type 1) |     | IP54 (UL Type 12) |     |                  |       |
|  | m <sup>3</sup> /h      | cfm | m <sup>3</sup> /h | cfm | W                | dB(A) |
| <i>U<sub>n</sub></i> = 400 V and 480 V |                        |     |                   |     |                  |       |
| 0145A-4                                | 685                    | 403 | 585               | 344 | 2487             | 67    |

| ACH580-07...   | Air flow               |      |                   |      | Heat dissipation | Noise |
|--|------------------------|------|-------------------|------|------------------|-------|
|  | IP21, IP42 (UL Type 1) |      | IP54 (UL Type 12) |      |                  |       |
|  | m <sup>3</sup> /h      | cfm  | m <sup>3</sup> /h | cfm  | W                | dB(A) |
| 0169A-4  | 700                    | 412  | 600               | 353  | 2497             | 67    |
| 0206A-4  | 700                    | 412  | 600               | 353  | 3314             | 67    |
| 0246A-4  | 800                    | 470  | 700               | 412  | 3806             | 65    |
| 0293A-4  | 800                    | 470  | 700               | 412  | 4942             | 65    |
| 0363A-4  | 1400                   | 824  | 1300              | 765  | 5868             | 68    |
| 0430A-4  | 1400                   | 824  | 1300              | 765  | 7600             | 68    |
| 0505A-4  | 1900                   | 1118 | 1900              | 1118 | 8353             | 72    |
| 0585A-4  | 1900                   | 1118 | 1900              | 1118 | 9471             | 72    |
| 0650A-4  | 1900                   | 1118 | 1900              | 1118 | 11200            | 72    |
| 0725A-4  | 2400                   | 1413 | 2400              | 1413 | 11386            | 72    |
| 0820A-4  | 2400                   | 1413 | 2400              | 1413 | 13725            | 72    |
| 0880A-4  | 2620                   | 1542 | 2620              | 1542 | 15300            | 71    |
| <b><math>U_n = 480\text{ V} - \text{UL (NEC) types}</math></b> |                        |      |                   |      |                  |       |
| 0124A-4  | 685                    | 403  | 585               | 344  | 2487             | 67    |
| 0156A-4  | 700                    | 412  | 600               | 353  | 2497             | 67    |
| 0180A-4  | 700                    | 412  | 600               | 353  | 3314             | 67    |
| 0240A-4  | 800                    | 470  | 700               | 412  | 3806             | 65    |
| 0260A-4  | 800                    | 470  | 700               | 412  | 4942             | 65    |
| 0361A-4  | 1400                   | 824  | 1300              | 765  | 5868             | 68    |
| 0414A-4  | 1400                   | 824  | 1300              | 765  | 7600             | 68    |
| 0505A-4  | 1900                   | 1118 | 1900              | 1118 | 8353             | 72    |
| 0585A-4  | 1900                   | 1118 | 1900              | 1118 | 9471             | 72    |
| 0650A-4  | 1900                   | 1118 | 1900              | 1118 | 11200            | 72    |
| 0725A-4  | 2400                   | 1413 | 2400              | 1413 | 11386            | 72    |
| 0820A-4  | 2400                   | 1413 | 2400              | 1413 | 13725            | 72    |
| 0880A-4  | 2620                   | 1542 | 2620              | 1542 | 15300            | 71    |

These losses are not calculated according to the ecodesign standard IEC 61800-9-2.

## Terminal and entry data for the power cables

### ■ IEC – Standard configuration

Input and motor cable terminal bolt sizes, accepted wire sizes (per three phases) and tightening torques are given below.

| Frame size | Input and motor cable connection terminals |           |                          |   |                                   |                          | PE (grounding) terminals     |                          |
|------------|--|-----------|--------------------------|---|-----------------------------------|--------------------------|------------------------------|--------------------------|
|            | L1, L2, L3                                 |           |                          | T1/U2, T2/V2, T3/W2                             |                                   |                          |                              |                          |
|            | Max. wire size<br>mm <sup>2</sup>          | Bolt size | Tightening torque<br>N·m | Min. wire size <sup>1)</sup><br>mm <sup>2</sup> | Max. wire size<br>mm <sup>2</sup> | Tightening torque<br>N·m | Bolt size<br>mm <sup>2</sup> | Tightening torque<br>N·m |
| R6         | 3×150                                      | M10       | 20...40                  | 3×25  | 3×150                             | 30                       | M10                          | 30...44                  |
| R7         | 3×240                                      | M10       | 20...40                  | 3×95  | 3×240                             | 40                       | M10                          | 30...44                  |
| R8         | 2×(3×150)                                  | M10       | 20...40                  | 2×(3×50)  | 2×(3×150)                         | 40                       | M10                          | 30...44                  |
| R9         | 2×(3×240)                                  | M12       | 50...75                  | 2×(3×95)  | 2×(3×240)                         | 70                       | M10                          | 30...44                  |
| R10        | 4×(3×150)                                  | M12       | 50...75                  | -   | 4×(3×150)                         | 50...75                  | M10                          | 30...44                  |
| R11        | 4×(3×240)                                  | M12       | 50...75                  | -   | 4×(3×240)                         | 50...75                  | M10                          | 30...44                  |

<sup>1)</sup> **Note:** Minimum wire size does not necessarily have enough current capability for full load. Make sure the installation complies with local laws and regulations.

### ■ IEC – With option +E205

Input and motor cable terminal bolt sizes, maximum accepted wire sizes (per three phases) and tightening torques are given below.

| Frame size | L1, L2, L3, U2, V2, W2            |           |                          | PE (grounding)               |                          |
|------------|-----------------------------------|-----------|--------------------------|------------------------------|--------------------------|
|            | Max. wire size<br>mm <sup>2</sup> | Bolt size | Tightening torque<br>N·m | Bolt size<br>mm <sup>2</sup> | Tightening torque<br>N·m |
| R6         | 3×120                             | M10       | 20...40                  | M10                          | 30...44                  |
| R7         | 3×240                             | M10       | 20...40                  | M10                          | 30...44                  |
| R8         | 2×(3×120)                         | M10       | 20...40                  | M10                          | 30...44                  |
| R9         | 2×(3×240)                         | M12       | 50...75                  | M10                          | 30...44                  |
| R10        | 4×(3×150)                         | M12       | 50...75                  | M10                          | 30...44                  |
| R11        | 4×(3×240)                         | M12       | 50...75                  | M10                          | 30...44                  |

### ■ US – Standard configuration

Input and motor cable terminal bolt sizes, accepted wire sizes (per three phases) and tightening torques are given below.

| Frame size | L1, L2, L3            |                |                             | T1/U2, T2/V2, T3/W2                 |                       |                             | PE (grounding) |                             |
|------------|-----------------------|----------------|-----------------------------|-------------------------------------|-----------------------|-----------------------------|----------------|-----------------------------|
|            | Max. wire size<br>AWG | Bolt size      | Tightening torque<br>lbf·ft | Min. wire size <sup>1)</sup><br>AWG | Max. wire size<br>AWG | Tightening torque<br>lbf·ft | Bolt size      | Tightening torque<br>lbf·ft |
| R6         | 3×300<br>MCM          | M10 (3/8")     | 22.1                        | 3                                   | 3×300<br>MCM          | 22.1                        | M10 (3/8")     | 29.5                        |
| R7         | 3×500<br>MCM          | M10 (3/8")     | 22.1                        | 3/0                                 | 3×500<br>MCM          | 22.1                        | M10 (3/8")     | 29.5                        |
| R8         | 2×(3×300<br>MCM)      | M10 (3/8")     | 22.1                        | 2×1/0 /<br>2×3/0 <sup>2)</sup>      | 2×(3×300<br>MCM)      | 22.1                        | M10 (3/8")     | 29.5                        |
| R9         | 2×(3×500<br>MCM)      | M12<br>(7/16") | 51.6                        | 2×3/0                               | 2×(3×500<br>MCM)      | 51.6                        | M10 (3/8")     | 29.5                        |
| R10        | 4×(3×300<br>MCM)      | M12<br>(7/16") | 51.6                        | -                                   | 4×(3×300<br>MCM)      | 51.6                        | M10 (3/8")     | 29.5                        |
| R11        | 4×(3×500<br>MCM)      | M12<br>(7/16") | 51.6                        | -                                   | 4×(3×500<br>MCM)      | 51.6                        | M10 (3/8")     | 29.5                        |

<sup>1)</sup> **Note:** Minimum wire size does not necessarily have enough current capability for full load. Make sure the installation complies with local laws and regulations.

<sup>2)</sup> -01-246A-4: 2×1/0, -01-293A-4: 2×3/0

### ■ US – With option +E205

Input and motor cable terminal bolt sizes, maximum accepted wire sizes (per three phases) and tightening torques are given below.

| Frame size | L1, L2, L3, U2, V2, W2 |               |                             | PE (grounding) |                             |
|------------|------------------------|---------------|-----------------------------|----------------|-----------------------------|
|            | Max. wire size<br>AWG  | Bolt size     | Tightening torque<br>lbf-ft | Bolt size      | Tightening torque<br>lbf-ft |
| R6         | 3×300 MCM              | M10 (3/8 in)  | 22.1                        | M10 (3/8 in)   | 30...44                     |
| R7         | 3×500 MCM              | M10 (3/8 in)  | 22.1                        | M10 (3/8 in)   | 30...44                     |
| R8         | 2×(3×300 MCM)          | M12 (7/16 in) | 51.6                        | M10 (3/8 in)   | 30...44                     |
| R9         | 2×(3×500 MCM)          | M12 (7/16 in) | 51.6                        | M10 (3/8 in)   | 30...44                     |
| R10        | 4×(3×300 MCM)          | M12 (7/16 in) | 51.6                        | M10 (3/8 in)   | 30...44                     |
| R11        | 4×(3×500 MCM)          | M12 (7/16 in) | 51.6                        | M10 (3/8 in)   | 30...44                     |

### ■ Dimension drawings

This table shows the dimensions of the power cable connection terminals. With a combination of bottom and top entry and exit options, look the connection points from the bottom entry and exit and top entry and exit drawings.

Frame R6: Input and motor cable terminal dimensions (bottom entry and exit, switch fuse OS250)

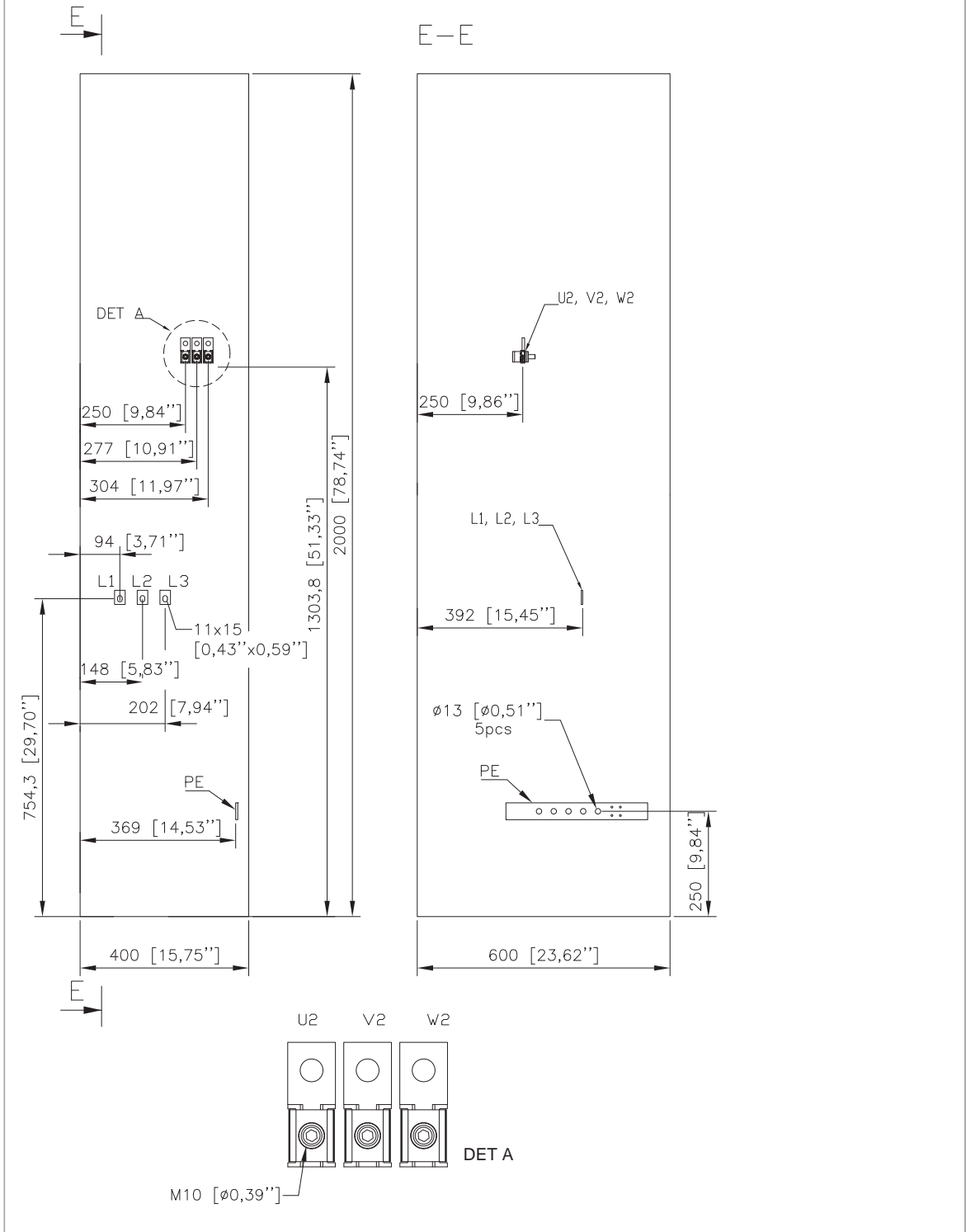





Frame R6: Input and motor cable terminal dimensions (option +F289)

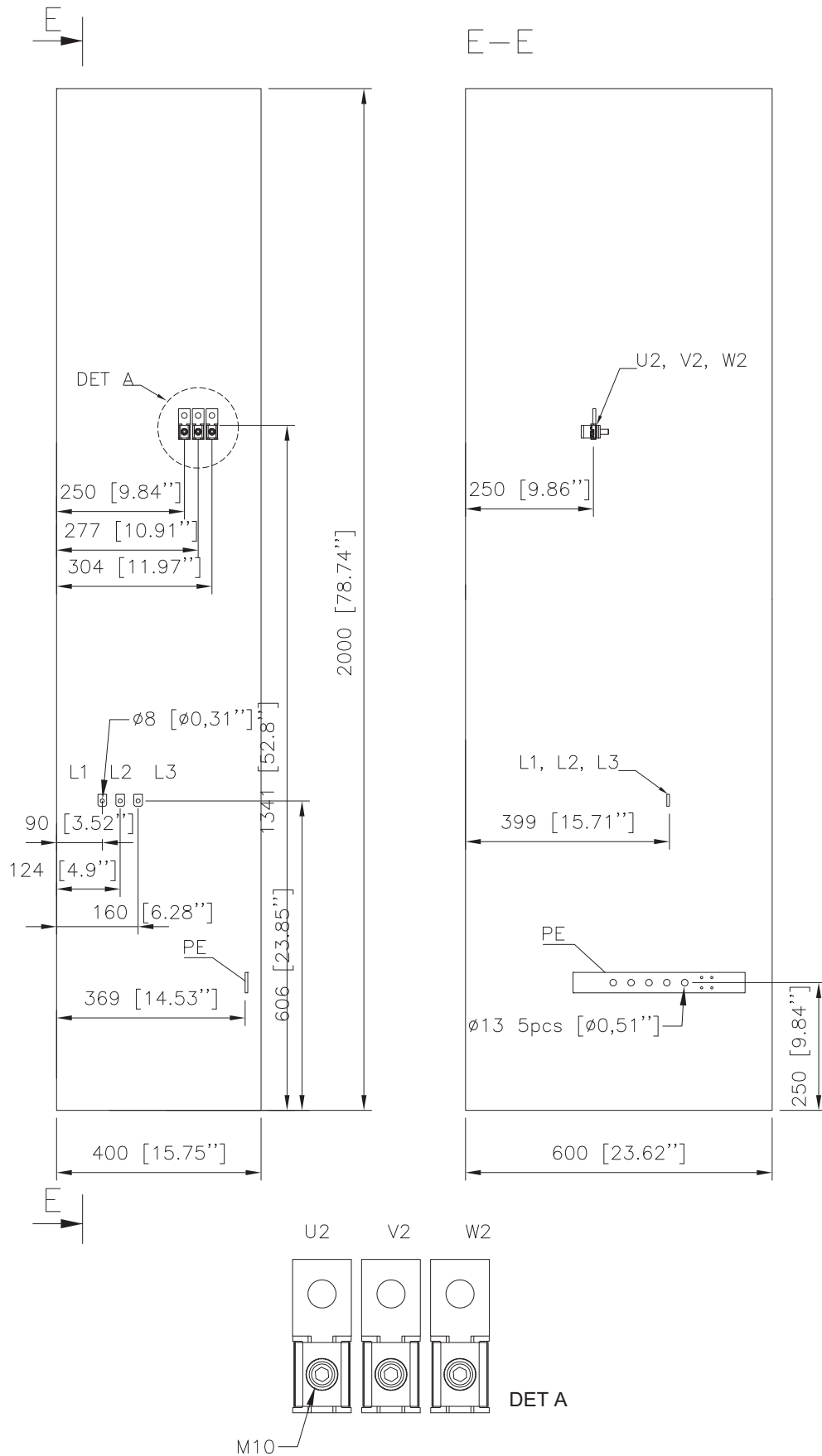

210 Technical data

Frame R7: Input and motor cable terminal dimensions (bottom entry and exit, switch fuse OS250)

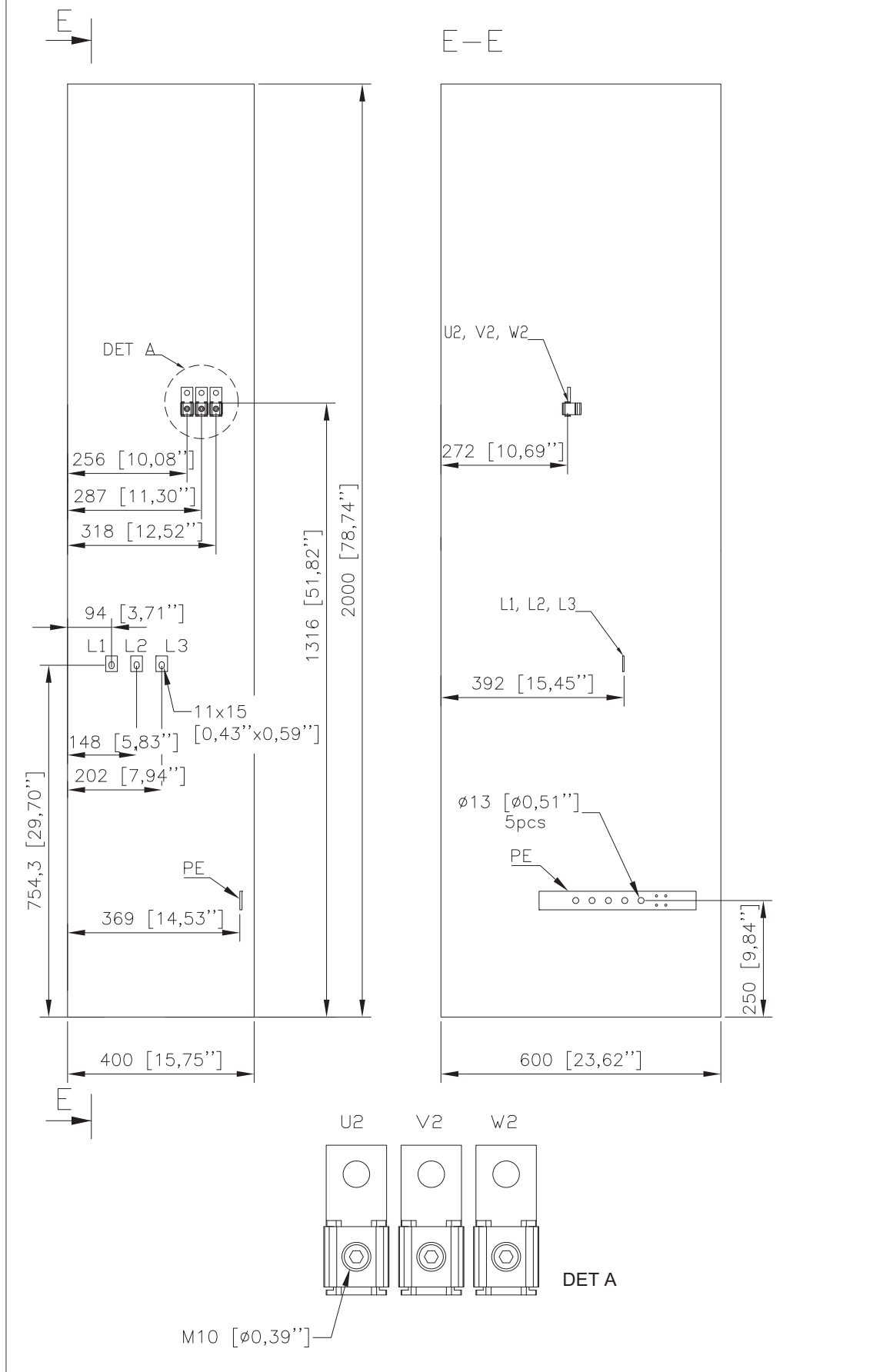

Frame R7: Input and motor cable terminal dimensions (bottom entry and exit, switch fuse OS400)

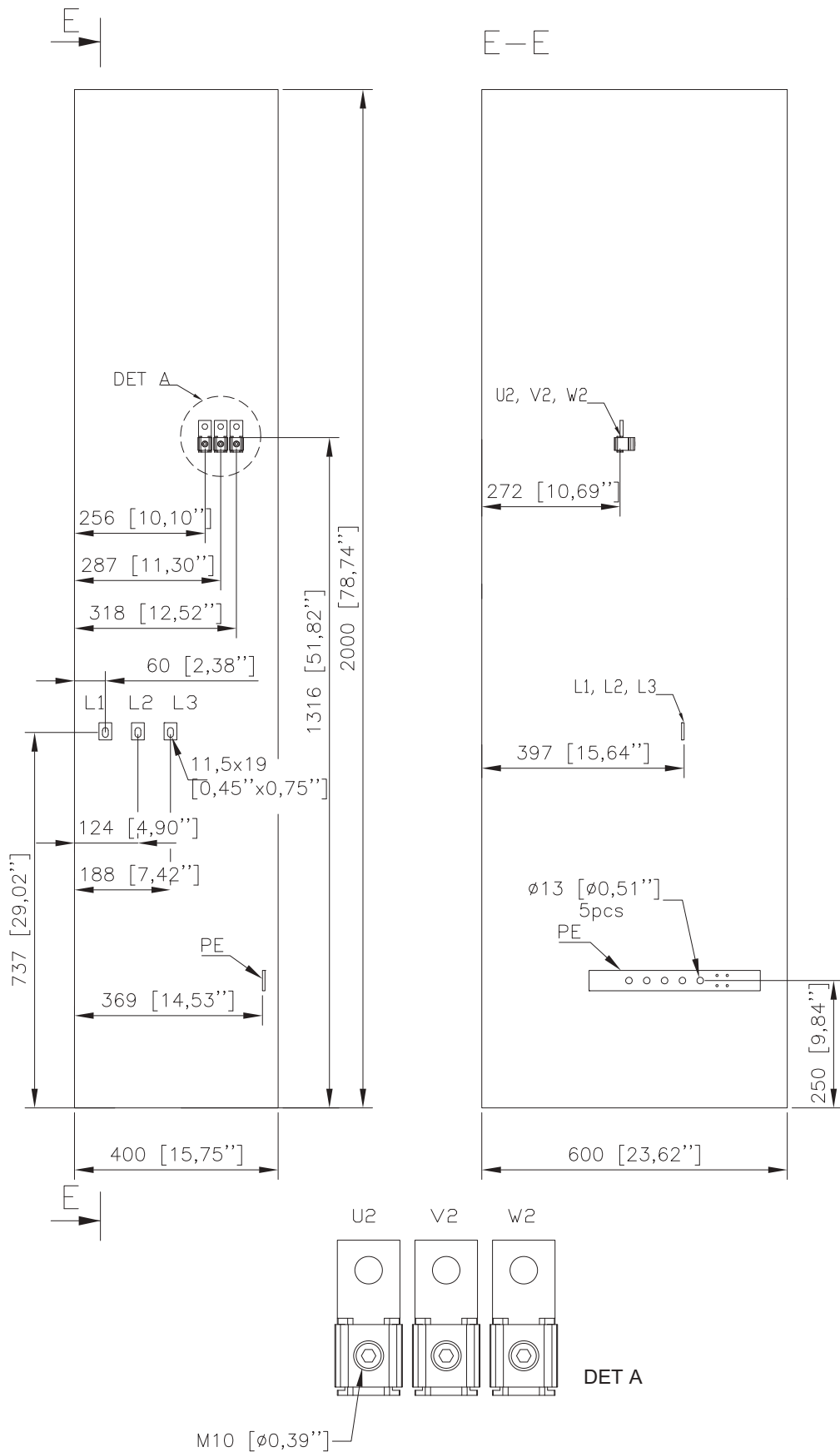

Frame R7: Input and motor cable terminal dimensions (bottom entry and exit, option +F289)

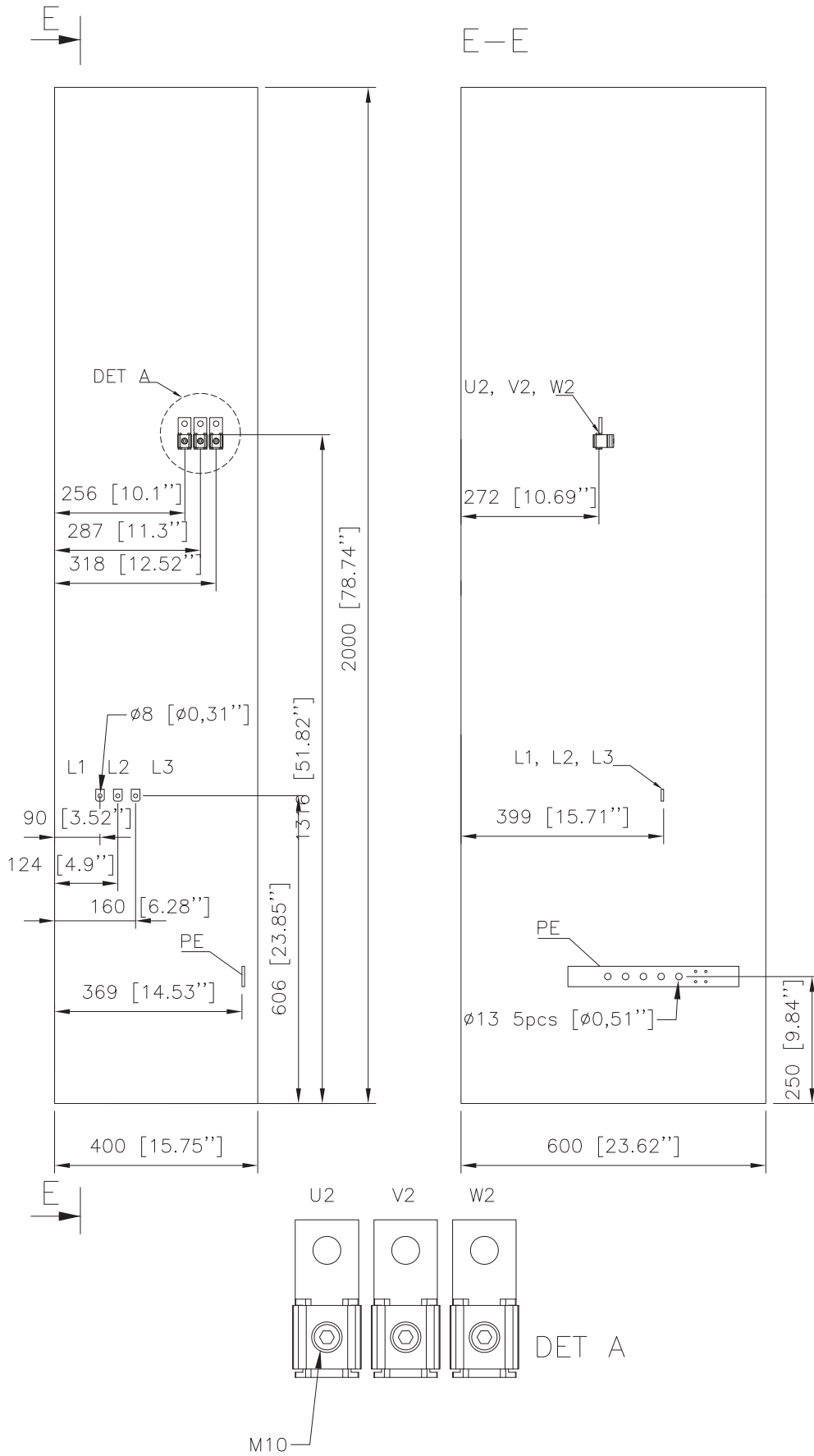

Frames R6 and R7: Input and motor cable terminal dimensions (bottom entry and exit, switch fuse OS250, du/dt filter [option +E205])

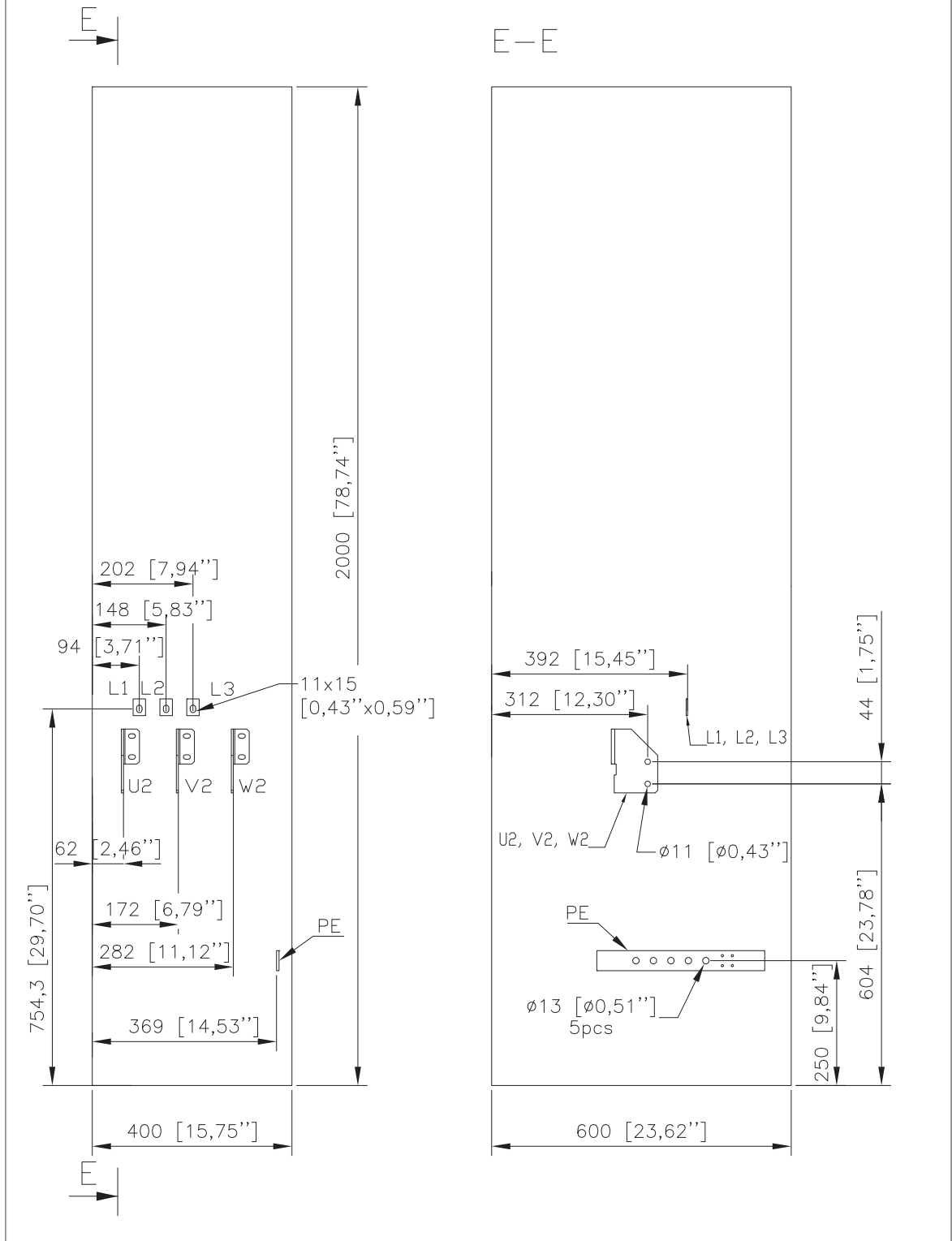

Frames R6 and R7: Input and motor cable terminal dimensions (bottom entry and exit, switch fuse OS400, du/dt filter [option +E205])

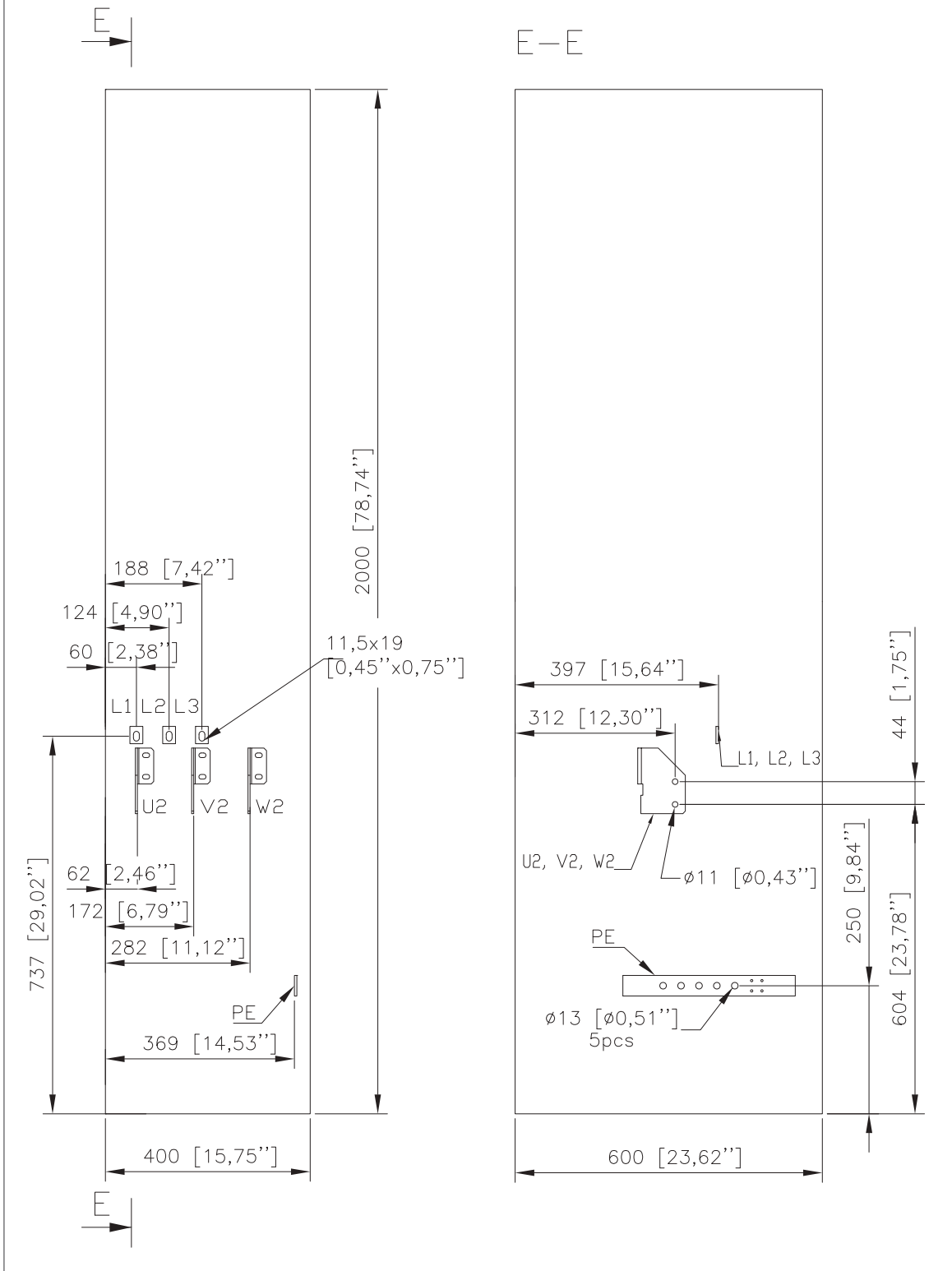

Frames R6 and R7: Input and motor cable terminal dimensions (bottom entry and exit, options +F289 and +E205)

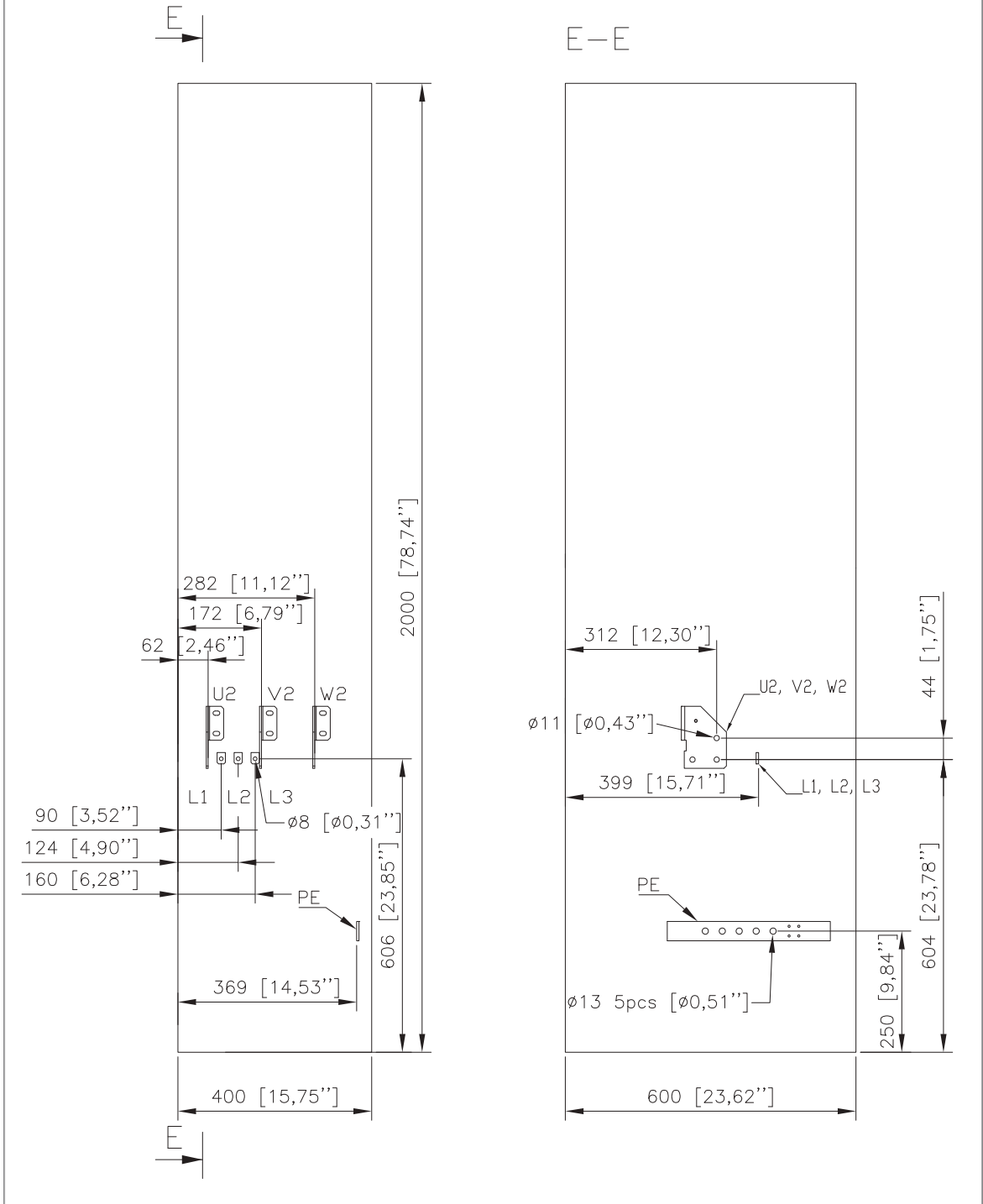

Frames R6 and R7: Input and motor cable terminal dimensions (top entry and exit, options +H351 and +H353)

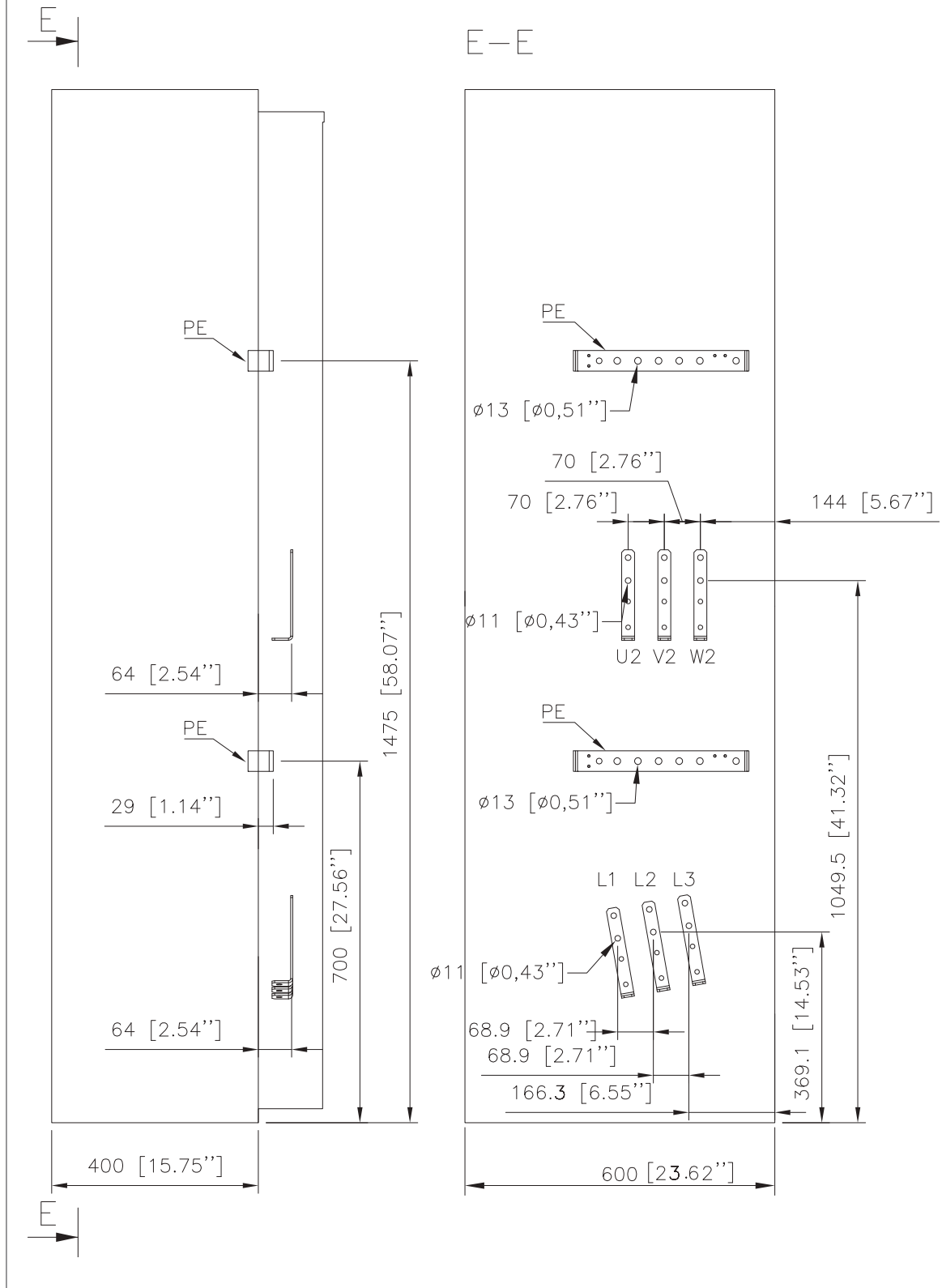



Frame R8: Input and motor cable terminal dimensions (bottom entry and exit, switch-disconnector OT400)

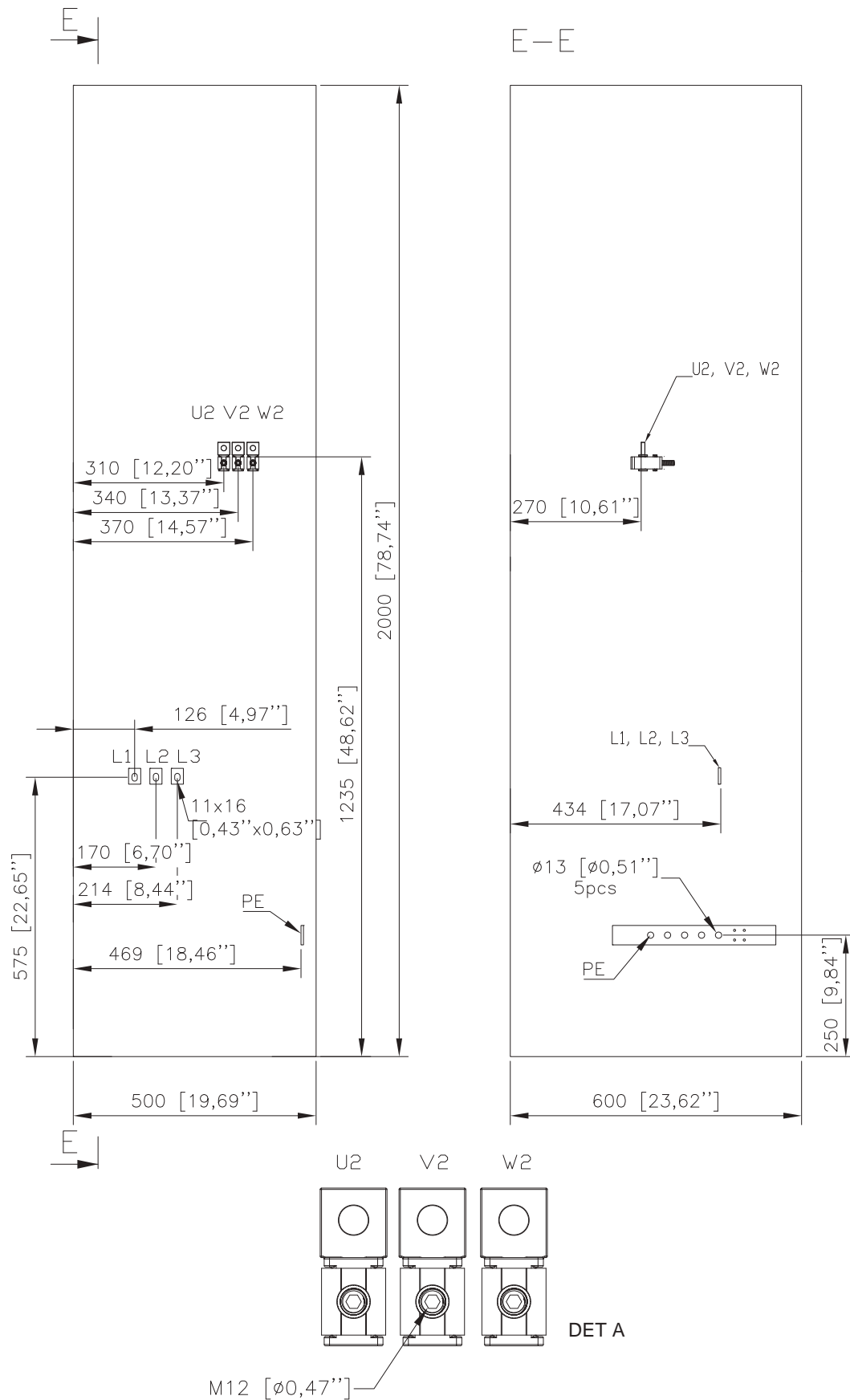

Frame R8: Input and motor cable terminal dimensions (bottom entry and exit, switch-disconnector OT400, du/dt filter [option +E205])

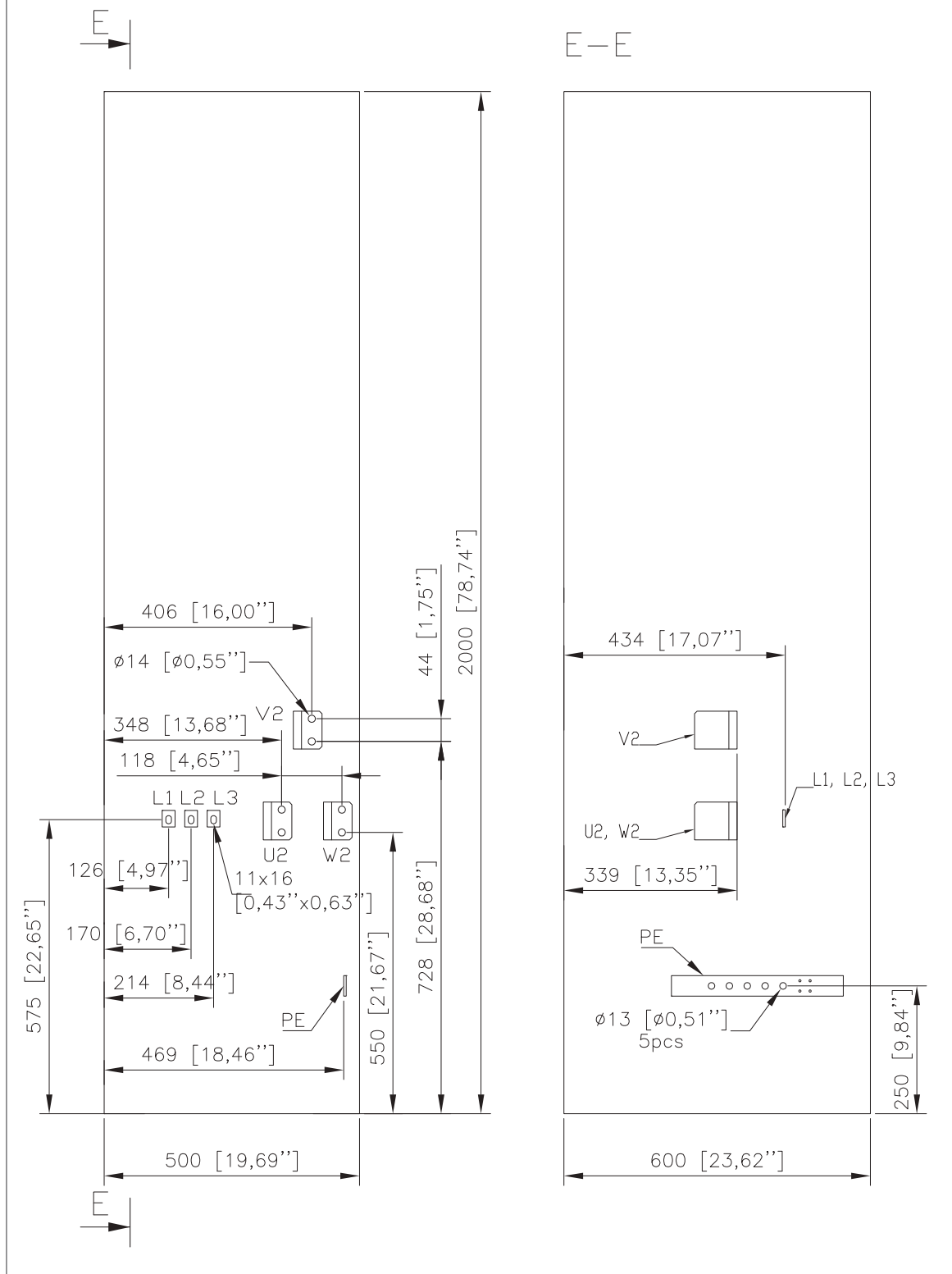

Frame R8: Input and motor cable terminal dimensions (bottom entry and exit, option +F289)

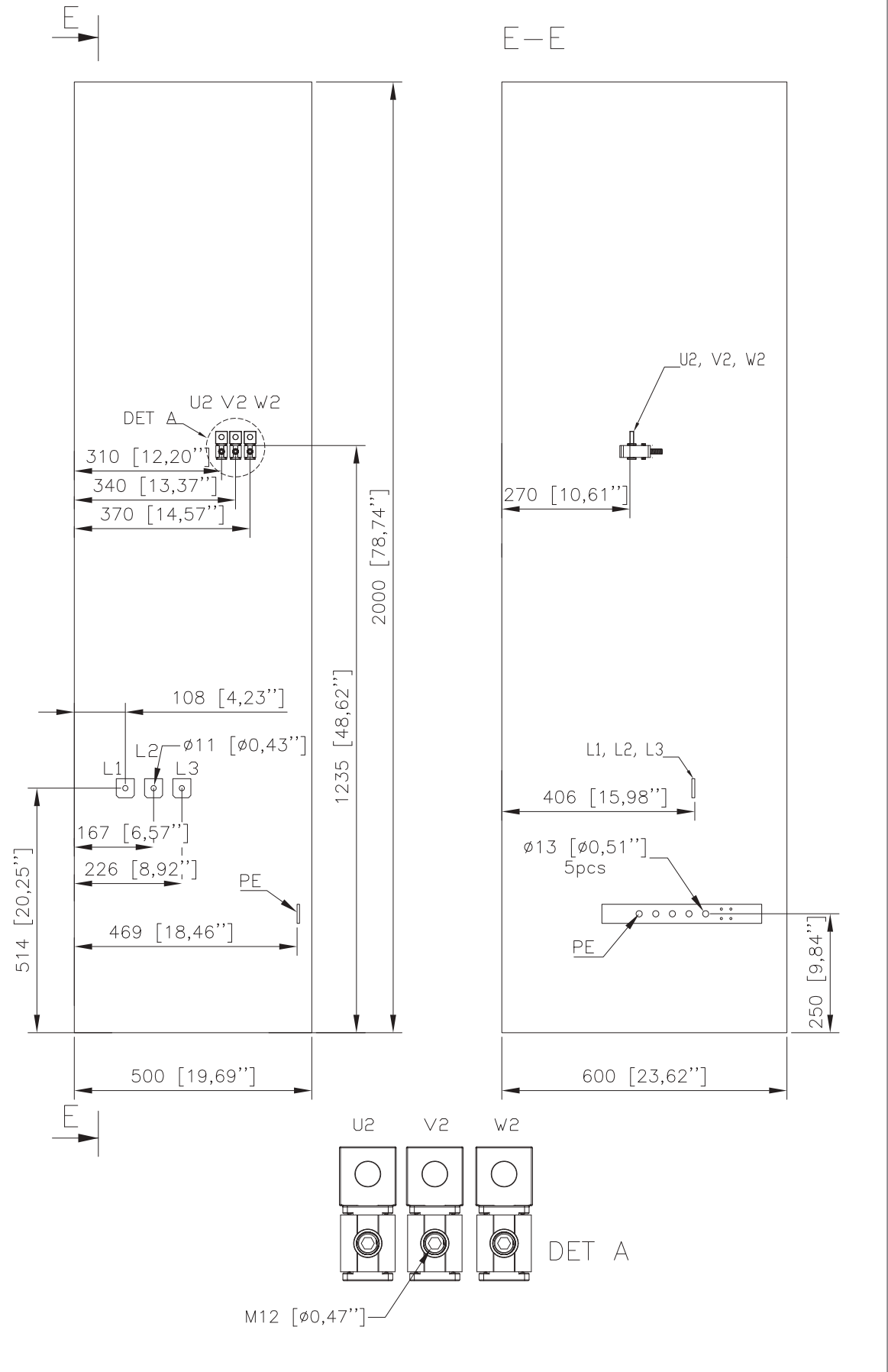

Frame R9: Input and motor cable terminal dimensions (bottom entry and exit, switch-disconnector OT630)

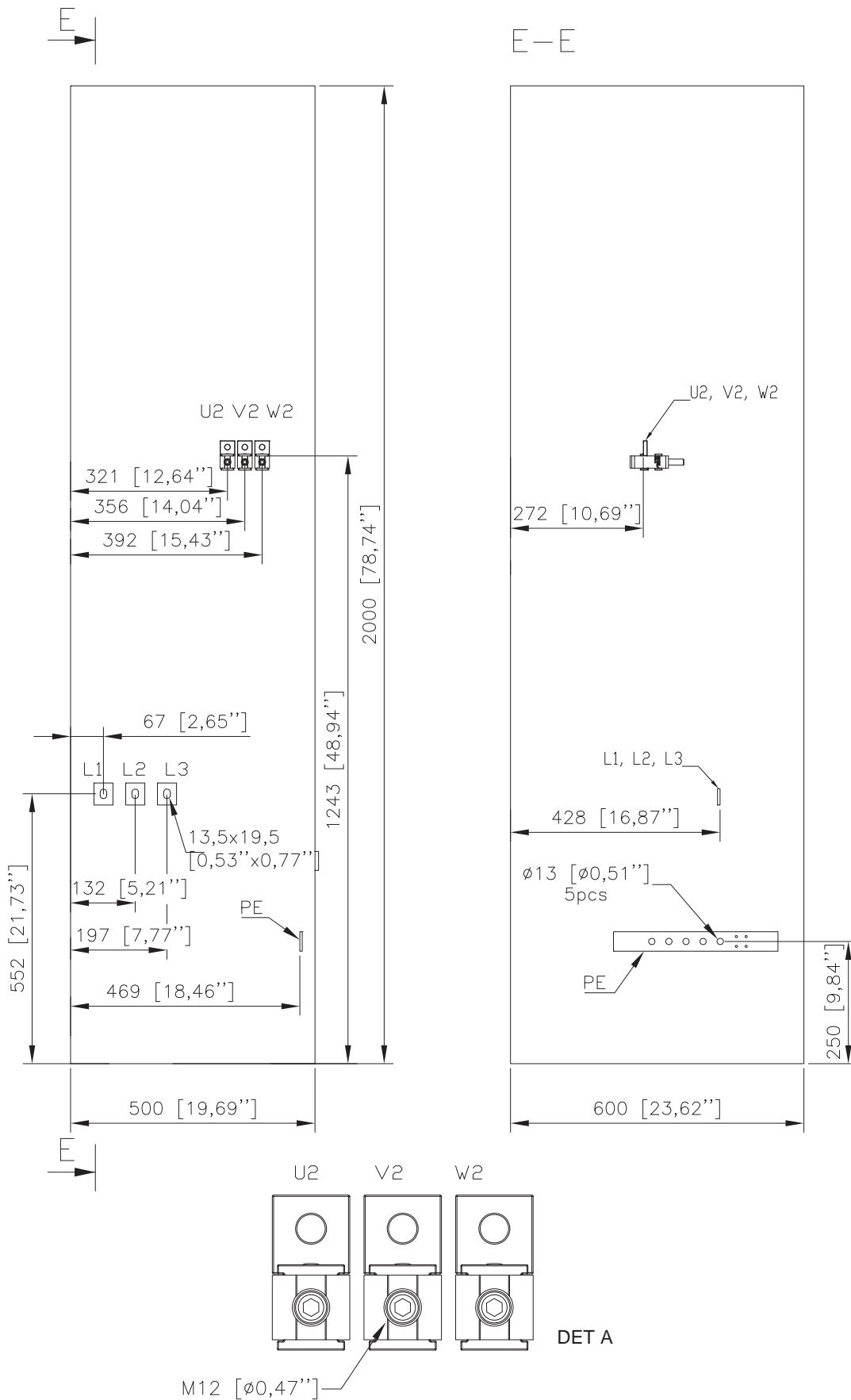

Frame R9: Input and motor cable terminal dimensions (bottom entry and exit, switch-disconnector OT630, du/dt filter [option +E205])

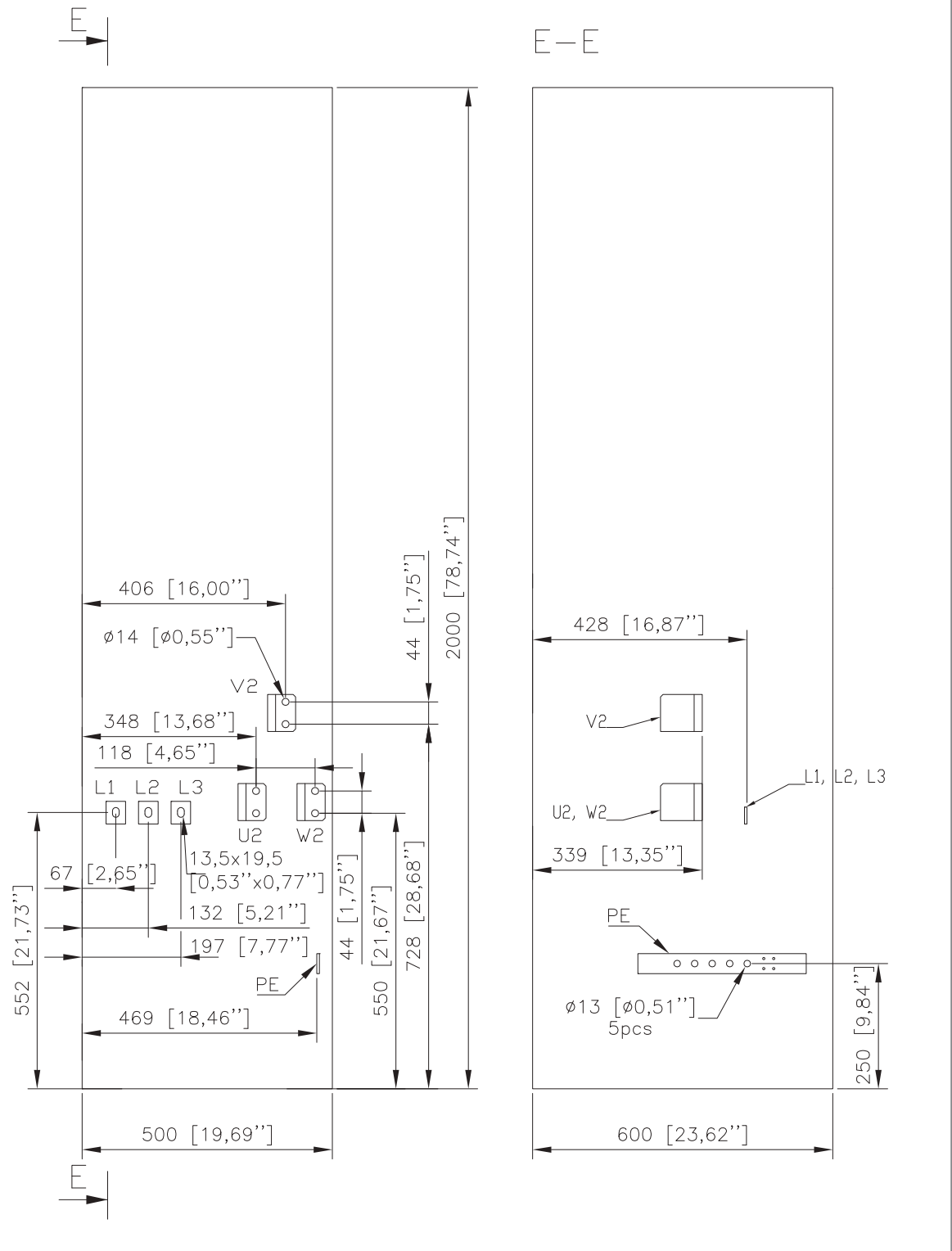

Frame R9: Input and motor cable terminal dimensions (option +F289)

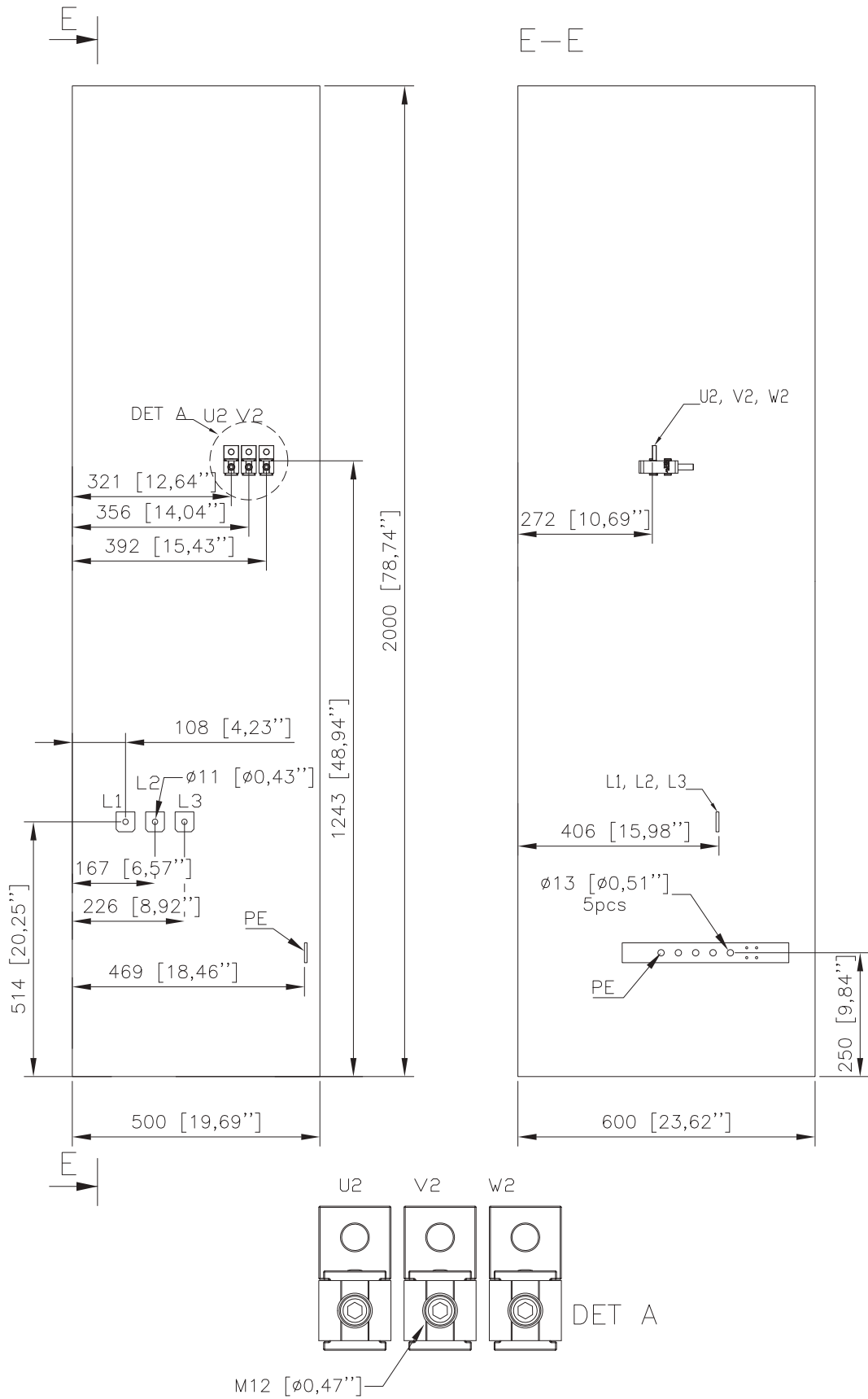

Frames R8 and R9: Input and motor cable terminal dimensions (bottom entry and exit, options +F289 and +E205)

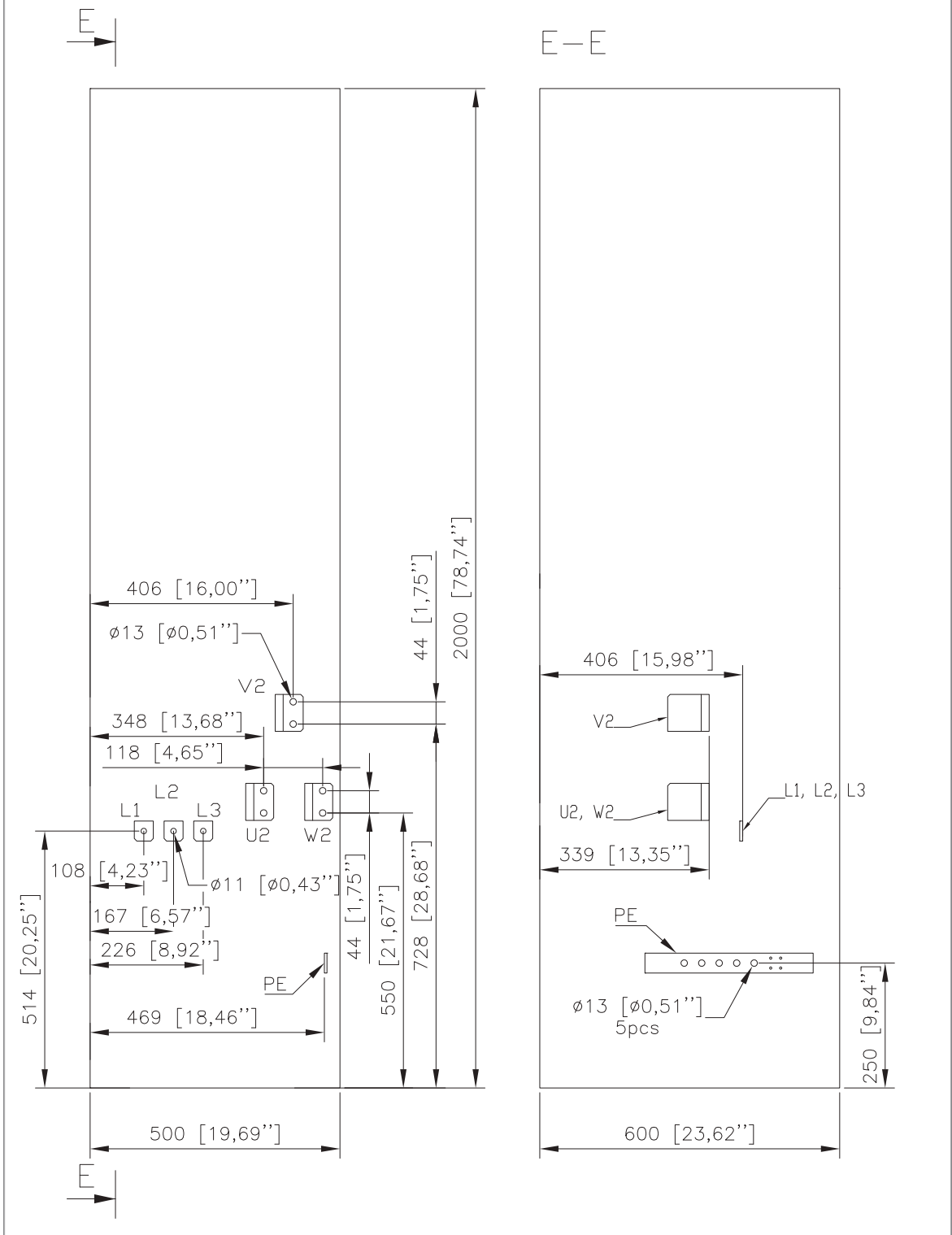

Frames R8 and R9: Input and motor cable terminal dimensions (top entry and exit, options +H351 and +H353)

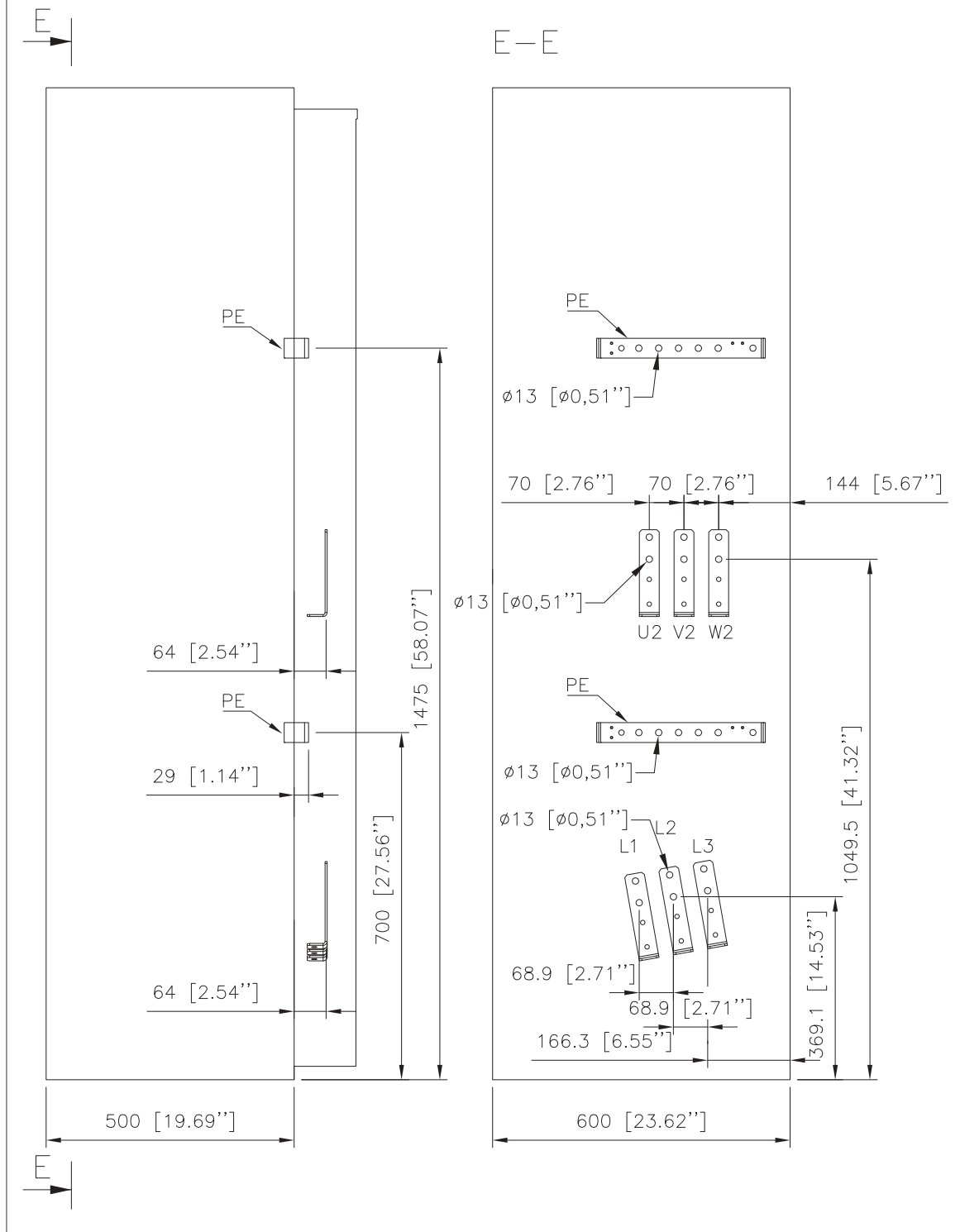



Frame R10: Input and motor cable terminal dimensions (bottom entry and exit)

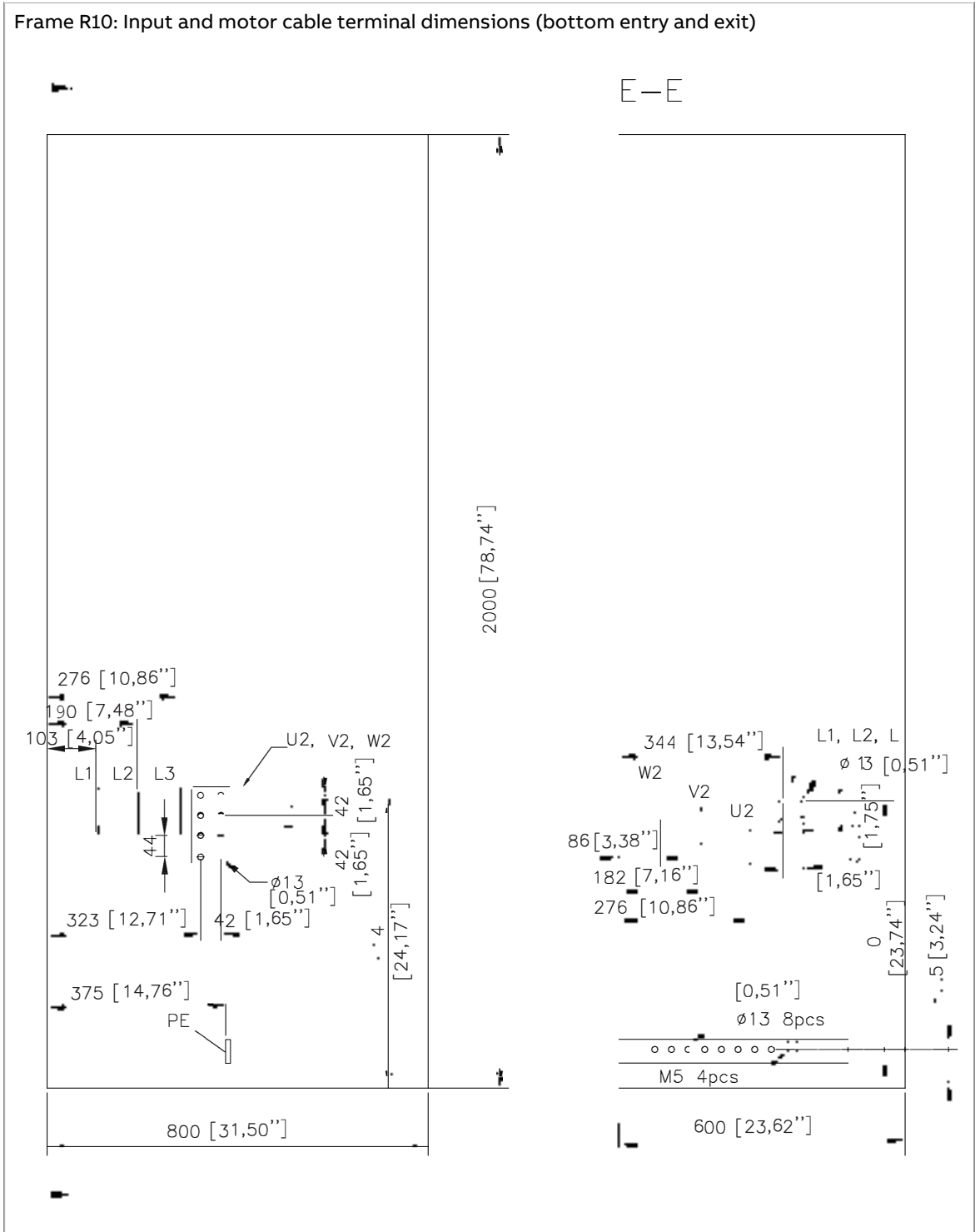

Frame R10: Input and motor cable terminal dimensions (bottom entry and exit, option +E205)

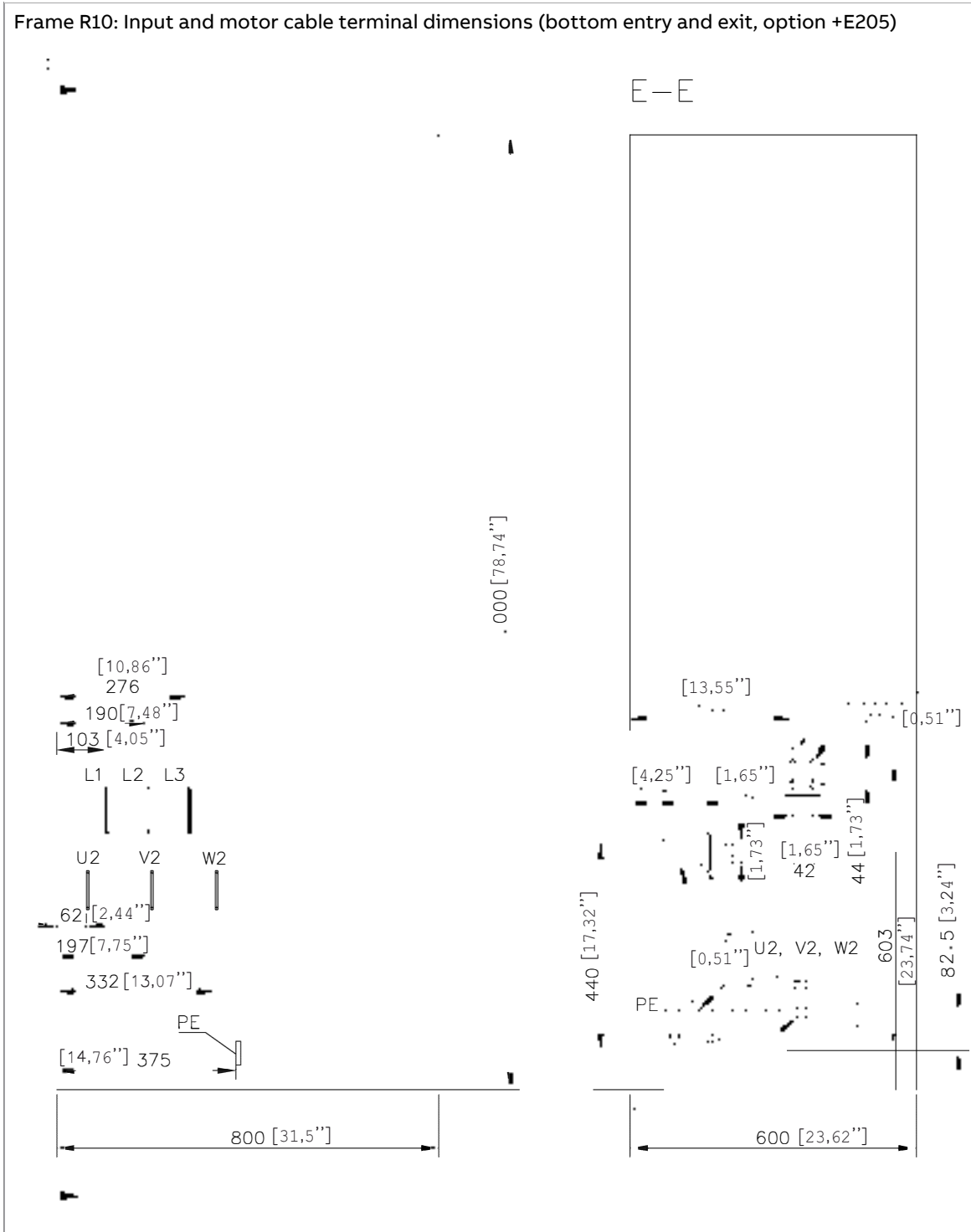

Frame R10: Input and motor cable terminal dimensions (top entry and exit)

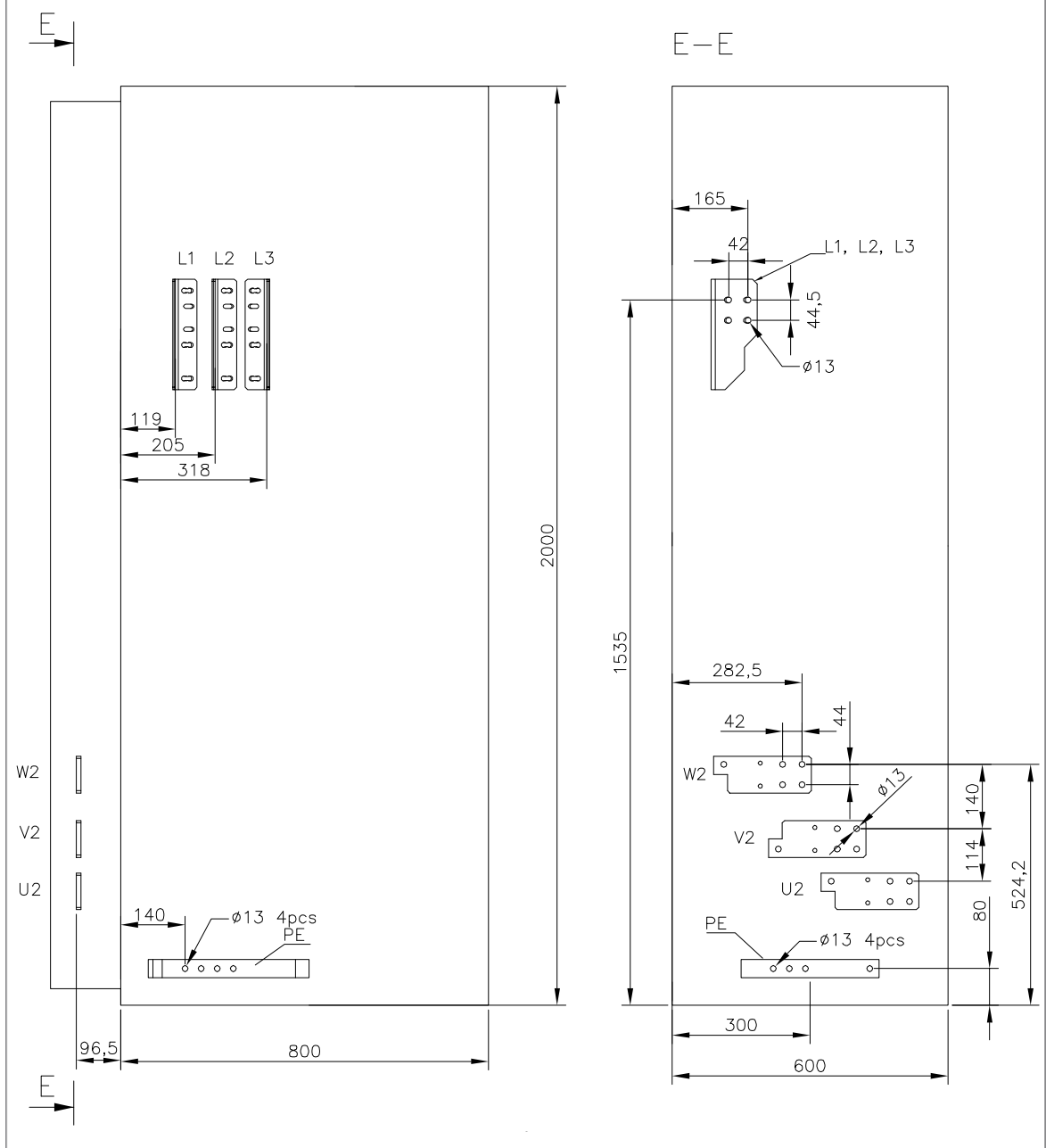

Frame R11: Input and motor cable terminal dimensions (bottom entry and exit)

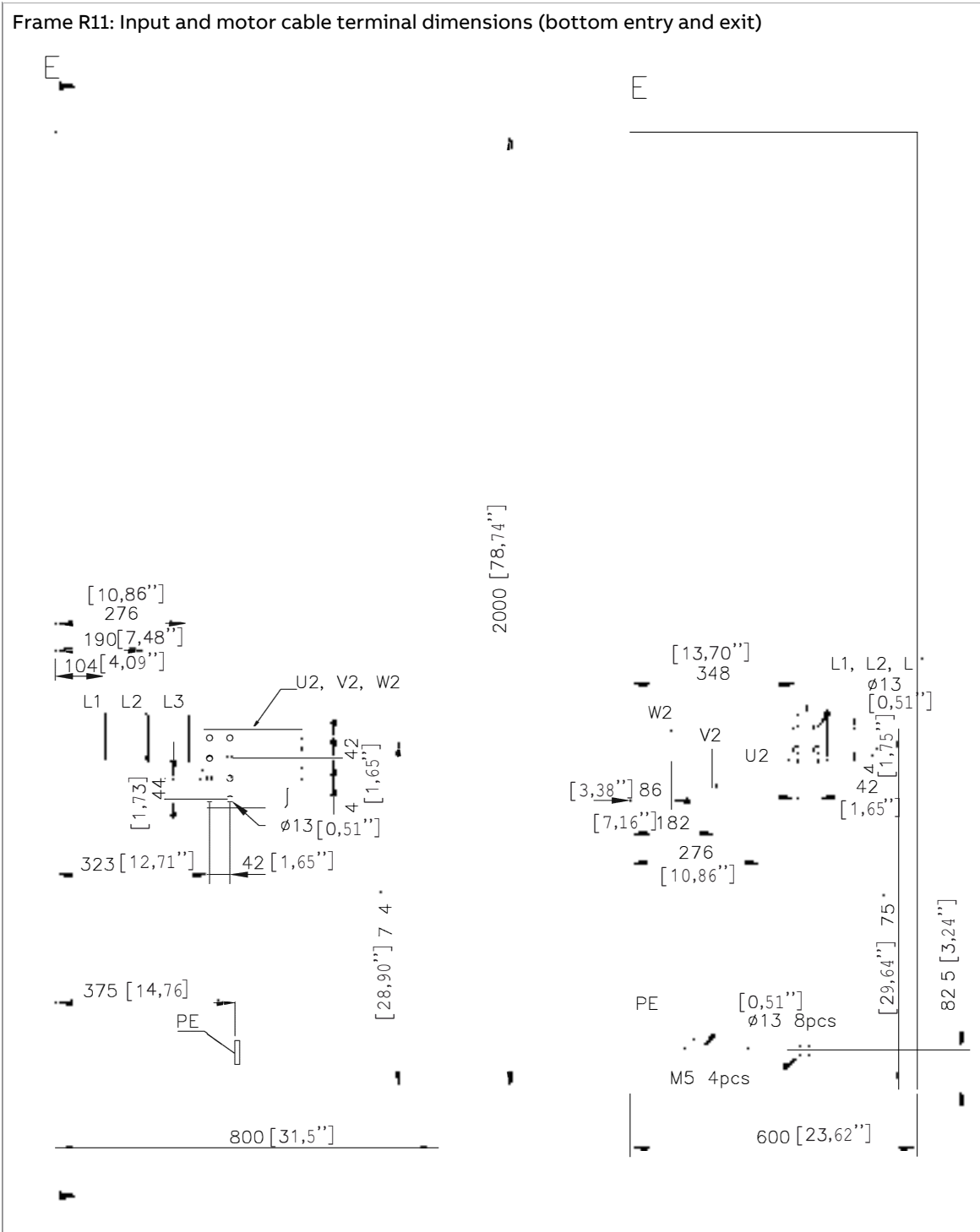

Frame R11: Input and motor cable terminal dimensions (bottom entry and exit, option +E205)

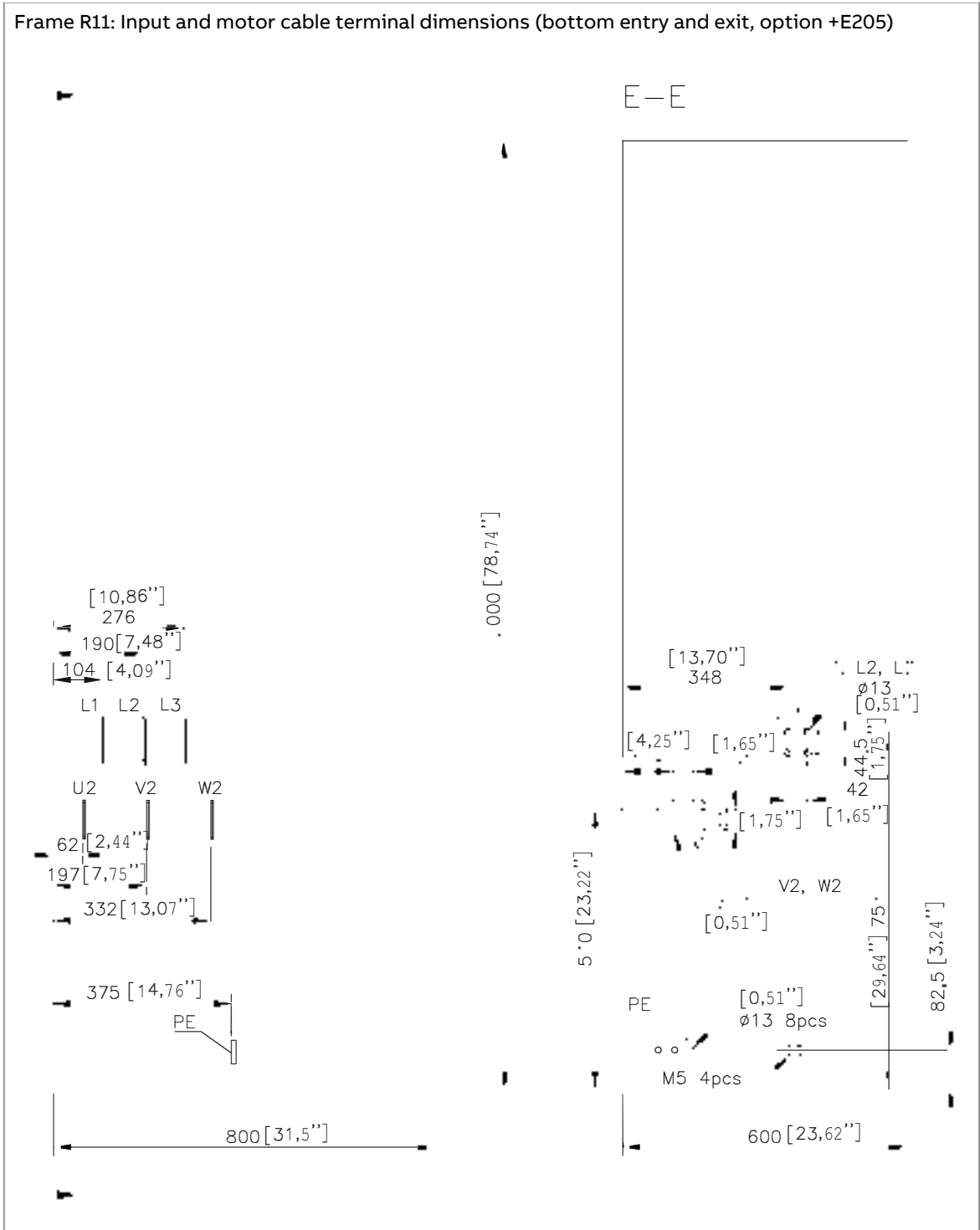

230 Technical data

Frame R11: Input and motor cable terminal dimensions (top entry and exit)

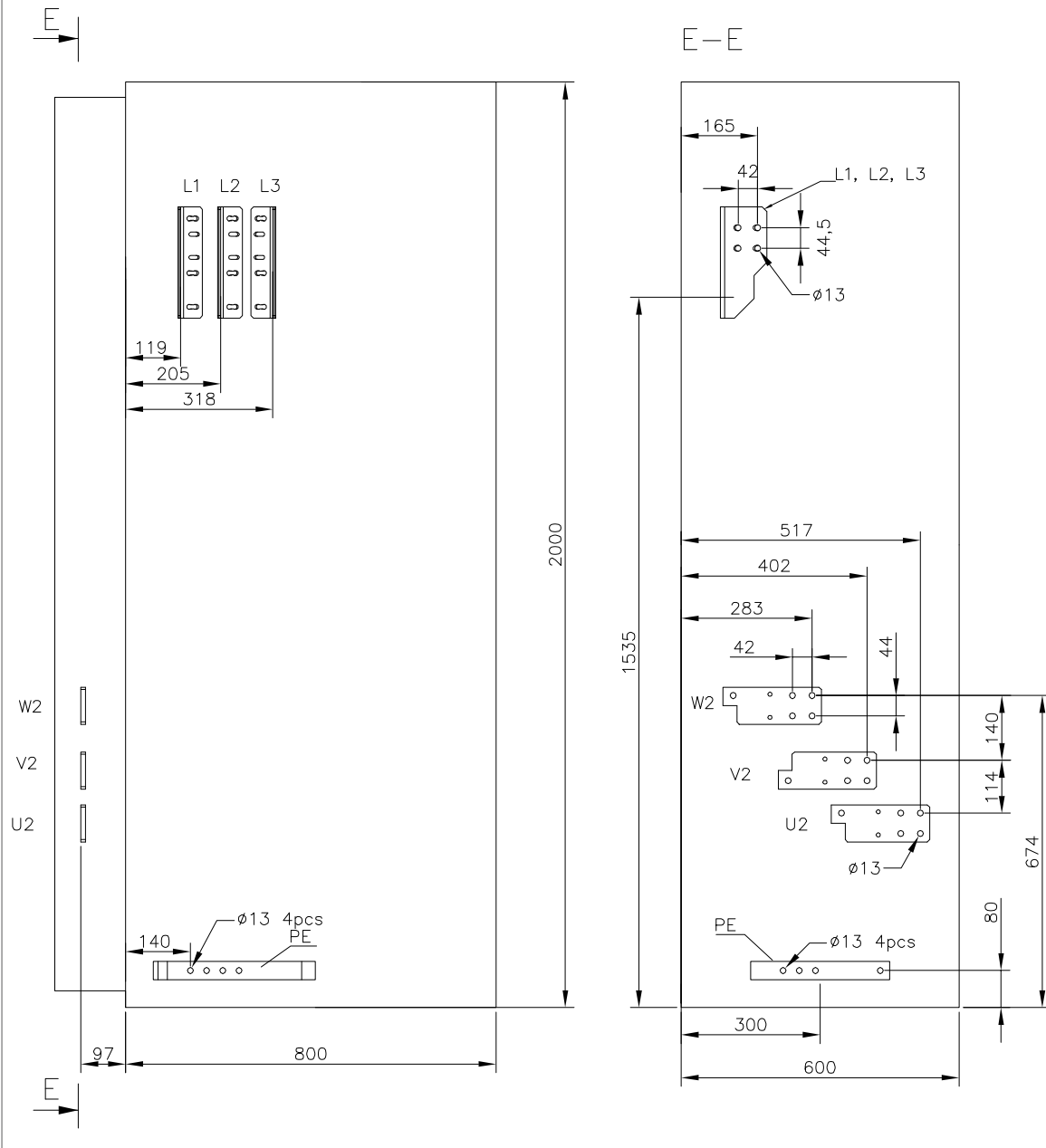

## Terminal and connection data for auxiliary control circuits

Maximum acceptable voltage and current values and wire sizes in terminal blocks are given below.

| Terminal block | Maximum acceptable voltage and current values and wire sizes  |
|----------------|---|
| X250           | 230V AC / 24V DC, 2A <ul style="list-style-type: none"> <li>• Solid wire 0,14...4 mm<sup>2</sup> (28...12 AWG)</li> <li>• Stranded wire 0,08...2,5 mm<sup>2</sup> (28...14 AWG)</li> </ul>  |
| X289           | 230V AC / 24V DC, 2A <ul style="list-style-type: none"> <li>• Solid wire 0,14...4 mm<sup>2</sup> (28...12 AWG)</li> <li>• Stranded wire 0,08...2,5 mm<sup>2</sup> (28...14 AWG)</li> </ul>  |
| X290           | 230V AC / 24V DC, 2A <ul style="list-style-type: none"> <li>• Solid wire 0,14...4 mm<sup>2</sup> (28...12 AWG)</li> <li>• Stranded wire 0,08...2,5 mm<sup>2</sup> (28...14 AWG)</li> </ul>  |
| X300           | 230V AC, 4A <ul style="list-style-type: none"> <li>• Solid wire 0,14...4 mm<sup>2</sup> (28...12 AWG)</li> <li>• Stranded wire 0,08...2,5 mm<sup>2</sup> (28...14 AWG)</li> </ul>   |
| X951           | 24V DC <ul style="list-style-type: none"> <li>• Solid wire 0,14...4 mm<sup>2</sup> (28...12 AWG)</li> <li>• Stranded wire 0,08...2,5 mm<sup>2</sup> (28...14 AWG)</li> </ul>  |
| X969           | 24V DC <ul style="list-style-type: none"> <li>• Solid wire 0,14...4 mm<sup>2</sup> (28...12 AWG)</li> <li>• Stranded wire 0,08...2,5 mm<sup>2</sup> (28...14 AWG)</li> </ul>  |
| X3             | 24V DC <ul style="list-style-type: none"> <li>• Solid wire 0,14...4 mm<sup>2</sup> (28...12 AWG)</li> <li>• Stranded wire 0,08...2,5 mm<sup>2</sup> (28...14 AWG)</li> </ul>  |
| X504           | 230V AC / 24V DC, 2A <ul style="list-style-type: none"> <li>• Solid wire 0,2...2,5 mm<sup>2</sup> (24...12 AWG)</li> <li>• Stranded wire with ferrule 0,25...2,5 mm<sup>2</sup> (24...14 AWG)</li> <li>• Stranded wire without ferrule 0,2 to 2,5 mm<sup>2</sup> (24 to 12 AWG).</li> </ul> Stripping length: 10 mm (0.5 in). |
| X601.1         | 480V AC, 20A <ul style="list-style-type: none"> <li>• Solid wire 0,75...16 mm<sup>2</sup> (18...6 AWG)</li> <li>• Stranded wire 0,75...16 mm<sup>2</sup> (18...6 AWG)</li> </ul>  |
| X601.1         | 230V AC / 24V DC, 2A <ul style="list-style-type: none"> <li>• Solid wire 0,2...2,5 mm<sup>2</sup> (24...14 AWG)</li> <li>• Stranded wire 0,2...2,5 mm<sup>2</sup> (24...14 AWG)</li> </ul>  |

## Electrical power network specification

|   |   |
|---|---|
| Voltage ( $U_1$ )   | <u>ACH580-07-xxxxx-4 drives</u> : 380...480 VAC 3-phase $\pm 10\%$ . This is indicated in the type designation label as typical input voltage levels 3~400/480 V AC.  |
| Network type  | TN (grounded) and IT (ungrounded) systems   |
| Short-circuit conditional current $I_{cc}$ (IEC/EN 61800-5-1) | Maximum allowable prospective short-circuit current is 65 kA when the input cable is protected with gG type fuses (IEC 60269) having maximum current rating as follows: <ul style="list-style-type: none"> <li>• 400 A for frames R6 to R8</li> <li>• 630 A for frame R9</li> <li>• 1000 A for frame R10</li> <li>• 1250 A for frame R11</li> </ul> |
| Short-circuit current protection (UL 508C)                    | The drive is suitable for use on a circuit capable of delivering not more than 100,000 rms symmetrical amperes at 480 V maximum when the input cable is protected with class T fuses.   |
| Frequency ( $f_1$ )   | 50/60 Hz. Variation $\pm 5\%$ of nominal frequency.   |
| Imbalance   | Max. $\pm 3\%$ of nominal phase to phase input voltage  |
| Fundamental power factor ( $\cos \phi_{i1}$ )                 | 0.98 (at nominal load)  |

## Motor connection data

|  |   |
|--|---|
| Motor types                            | Asynchronous AC induction motors, permanent magnet synchronous motors   |
| Voltage ( $U_2$ )                      | 0 to $U_1$ , 3-phase symmetrical. This is indicated in the type designation label as typical output voltage level 3 ~ 0... $U_1$ . $U_{max}$ at the field weakening point.  |
| Frequency ( $f_2$ )                    | 0...598 Hz<br><u>For drives with du/dt filter</u> : 500 Hz  |
| Current                                | See section <a href="#">Electrical ratings (page 191)</a> .   |
| Switching frequency                    | 3 kHz (typically)   |
| Maximum recommended motor cable length | 300 m (984 ft).<br>Longer cables cause a motor voltage decrease which limits the available motor power. The decrease depends on the motor cable length and characteristics. Note that a sine filter (optional) at the drive output also causes a voltage decrease. Contact ABB for more information.<br><br><b>Note:</b> The maximum motor cable length for the EMC compliance is 100 m (328 ft). |

## Control unit connection data

See chapter [Control unit \(page 131\)](#).

## Efficiency

Approximately 98% at nominal power level

The efficiency is not calculated according to the ecodesign standard IEC 61800-9-2.



## Energy efficiency data (ecodesign)

Energy efficiency data is not provided for the drive. The cabinet-installed drives comprising drive modules which are in conformity with the regulation are exempt from the EU ecodesign requirements (Regulation EU/2019/1781, §2.3.e) and the UK ecodesign requirements (Regulation SI 2021 No. 745).

## Protection classes

|                                       |   |
|---------------------------------------|---|
| Degrees of protection (IEC/EN 60529)  | IP21 (standard), IP42 (option +B054), IP54 (option +B055)   |
| Enclosure types (UL50)                | UL Type 1 (standard), UL Type 1 (option +B054), UL Type 12 (Standard). For indoor use only.   |
| Arcing class (IEC TR 61641)           | B – ASSEMBLY providing personnel and ASSEMBLY protection under arcing conditions.<br>Tested at the following voltage with an arcing current of 65 kA for 300 milliseconds: <ul style="list-style-type: none"> <li>• 400 V units (indicated by "-4" in drive type): 420 V</li> <li>• 500 V units (indicated by "-5" in drive type): 550 V</li> <li>• 690 V units (indicated by "-7" in drive type): 760 V</li> </ul> |
| Overvoltage category (IEC/EN 60664-1) | III, except for auxiliary power connections (fan, control, heating, lighting etc) which are category II.  |
| Protective class (IEC/EN 61800-5-1)   | I   |

## Ambient conditions

Environmental limits for the drive are given below. Use the drive in a heated, indoor, controlled environment.

|   | <b>Operation</b><br>installed for stationary use   | <b>Storage</b><br>in the protective package   | <b>Transportation</b><br>in the protective package   |
|---|--|---|--|
| <b>Installation site altitude</b>   | 0 to 2000 m (6561 ft) above sea level. For altitudes above 1000 m (3281 ft), refer to section <a href="#">Altitude derating (page 194)</a> .<br>For altitudes above 2000 m, contact ABB. | -   | -  |
| <b>Air temperature</b>  | -0 to +50 °C (32 to 122 °F). Above 40 °C (108 °F), refer to section <a href="#">Ambient temperature derating (page 194)</a>  | -40 to +70 °C (-40 to +158 °F)  | -40 to +70 °C (-40 to +158 °F)   |
| <b>Relative humidity</b>  | 5 to 95%   | Max. 95%  | Max. 95%   |
|   | No condensation allowed. Maximum allowed relative humidity is 60% <sup>1)</sup> in the presence of corrosive gases.  |   |  |
| <b>Contamination levels</b>   | IEC 60721-3-3:2019<br>ISO 9223<br>ANSI-ISA 71.04   | IEC 60721-3-1:1997  | IEC 60721-3-2:1997   |
| <b>Chemical gases</b>   | IEC Class C3 <sup>2)</sup><br>ANSI-ISA 71.04 Class G2  | Class 1C2   | Class 2C2  |
|   | Conformal coated circuit boards as standard on all drives  |   |  |
| <b>Solid particles</b>  | Class 3S6<br>No conductive dust allowed  | Class 1S3 if the package is Class 2S2, otherwise Class 1S2  | Class 2S2  |
| <b>Pollution degree</b><br>IEC/EN 60664-1                                     | 2  | -   | -  |
| <b>Atmospheric pressure</b>   | 70...106 kPa 0.7...1.05 atmospheres  | 70...106 kPa 0.7...1.05 atmospheres   | 60...106 kPa 0.6...1.05 atmospheres  |
| <b>Vibration</b><br>IEC 61800-5-1<br>IEC 60068-2-6:2007,<br>EN 60068-2-6:2008 | Max. 0.075 mm (0.003 in) (10...57 Hz),<br>max. 10 m/s <sup>2</sup> (33 ft/s <sup>2</sup> ) (57...150 Hz) sinusoidal  | Max. 0.075 mm (0.003 in) (10...57 Hz),<br>max. 10 m/s <sup>2</sup> (33 ft/s <sup>2</sup> ) (57...150 Hz) sinusoidal | Max. 3.5 mm (0.14 in) (2...9 Hz),<br>max. 10 m/s <sup>2</sup> (33 ft/s <sup>2</sup> ) (9...20 Hz) sinusoidal |
| <b>Shock</b><br>IEC 60068-2-27:2008,<br>EN 60068-2-27:2009                    | Not allowed  | With packing max. 100 m/s <sup>2</sup> (330 ft/s <sup>2</sup> ), 11 ms  | With packing max. 100 m/s <sup>2</sup> (330 ft/s <sup>2</sup> ), 11 ms                                       |

<sup>1)</sup> Contact ABB for higher humidity levels than 60% in the presence of corrosive gases.

<sup>2)</sup> For IEC 60721-3-3:2002, the level is 3C2 as standard.

## Transportation

The table below specifies the transportation methods and conditions for the drive. Seaworthy package (option +P912) is required for non-weather protected transportation conditions.

| Package type   | Method   | Weather-protected conditions (IEC 60721-3-2)                                  | Non-weather protected conditions (IEC 60721-3-2)             |
|--|--|---|--|
| Standard package<br>Wooden crate<br>Vertical   | Road, air, sea (in container).<br>Special vehicle requirements: High-cube container. ABB recommends the use of container desiccant bags in sea transportation.                 | <b>2K12:</b> Transportation without temperature and humidity control allowed. | Not allowed.   |
| Seaworthy package (option +P912)<br>Wooden crate covered with plywood sheets<br>Vertical                 | Road, air, sea (in container).<br>Special vehicle requirements: High-cube container. ABB recommends the use of container desiccant bags in sea transportation.                 | <b>2K12:</b> Transportation without temperature and humidity control allowed. | <b>2K14:</b> Non-weather-protected transportation worldwide. |
| Standard package<br>Cardboard box<br>Horizontal <sup>1)</sup>  | Road, rail, air, sea (in container).<br>Special vehicle requirements: Preferred for air and courier. ABB recommends the use of container desiccant bags in sea transportation. | <b>2K12:</b> Transportation without temperature and humidity control allowed. | Not allowed.   |
| Seaworthy package (option +P912)<br>Wooden crate covered with plywood sheets<br>Horizontal <sup>1)</sup> | Road, rail, air, sea.<br>Special vehicle requirements: Preferred for sea transportation. ABB recommends the use of container desiccant bags in sea transportation.             | <b>2K12:</b> Transportation without temperature and humidity control allowed. | <b>2K14:</b> Non-weather-protected transportation worldwide. |

<sup>1)</sup> Drive widths up to 830 mm can be delivered in a horizontal package. Factory makes the final decision on the packing position. It depends, for example, on the drive size and options, and the transportation method.

## Storage conditions

The table below specifies the storage conditions for the drive. Store the drive in its package. ABB recommends seaworthy package (option +P912) if the drive is in long-term storage. The storage conditions must also comply with the environmental limits specified in .

| Package type   | Storage conditions (IEC 60721-3-1)   |
|--|--|
| Standard package<br>Wooden crate<br>Vertical   | <p><b>1K20:</b> Up to 24 months in enclosed conditions (full temperature and humidity control).</p> <p><b>1K22:</b> Up to 6 months in enclosed conditions (no temperature or humidity control).</p> <p><b>1K23, 1K24:</b> Up to 3 months in sheltered conditions (roof providing protection from direct rain and sun).</p> <p><b>1K25...1K27:</b> Up to 48 hours between loading operations in open-air conditions (no protection).</p>                        |
| Seaworthy package<br>(option +P912)<br>Wooden crate covered<br>with plywood sheets<br>Vertical | <p><b>1K20:</b> Up to 24 months in enclosed conditions (full temperature and humidity control).</p> <p><b>1K22:</b> Up to 12 months in enclosed conditions (no temperature or humidity control).</p> <p><b>1K23, 1K24:</b> Up to 12 months in sheltered conditions (roof providing protection from direct rain and sun).</p> <p><b>1K25...1K27:</b> Up to 1 month in open-air conditions (no protection). Not recommended, but can be temporarily allowed.</p> |
| Standard package<br>Cardboard box<br>Horizontal  | <p><b>1K20:</b> Up to 24 months in enclosed conditions (full temperature and humidity control).</p> <p><b>1K22:</b> Up to 6 months in enclosed conditions (no temperature or humidity control).</p> <p><b>1K23, 1K24:</b> Up to 2 months in sheltered conditions (roof providing protection from direct rain and sun).</p> <p><b>1K25...1K27:</b> Storing in open-air conditions (no protection) is not allowed.</p>   |
| Seaworthy package<br>(option +P912)<br>Plywood box<br>Horizontal                               | <p><b>1K20:</b> Up to 24 months in enclosed conditions (full temperature and humidity control).</p> <p><b>1K22:</b> Up to 12 months in enclosed conditions (no temperature or humidity control).</p> <p><b>1K23, 1K24:</b> Up to 6 months in sheltered conditions (roof providing protection from direct rain and sun).</p> <p><b>1K25...1K27:</b> Up to 1 month in open-air conditions (no protection). Not recommended, but can be temporarily allowed.</p>  |

## Auxiliary circuit power consumption

|  |                              |
|--|------------------------------|
| Cabinet heater (option +G300)                              | 100 W                        |
| External uninterruptible 150 W power supply (option +G307) | 150 W                        |
| Motor heater (option +G313)                                | According to the heater type |

## Color

Cabinet: RAL Classic 7035

## Materials

### ■ Drive

Refer to ACS580-07, ACH580-07 and ACQ580-07 cabinet-installed drive modules recycling instructions and environmental information ([3AXD50000153893](#)).

### ■ Package materials for cabinet-installed low-power single drives

- Cardboard heavy duty quality with wet strength glue
- Plywood<sup>1)</sup>
- Wood
- PET (strapping)
- PE (VCI film)
- Metal (fixing clamps, screws)
- Clay desiccant.

<sup>1)</sup> Horizontal package only: Also cardboard hoods are used instead.

### ■ Package materials for options, accessories and spare parts

- Cardboard
- Kraft paper
- PP (straps)
- PE (film, bubble wrap)
- Plywood, wood (only for heavy components).

Materials vary according to the item type, size and shape. Typical package consists of a cardboard box with paper filling or bubble wrap. ESD-safe packing materials are used for printed circuit boards and similar items.

### ■ Materials of manuals

Printed product manuals are made of recyclable paper. Product manuals are available on the Internet.

## Disposal

The main parts of the drive can be recycled to preserve natural resources and energy. Product parts and materials should be dismantled and separated.

Generally all metals, such as steel, aluminum, copper and its alloys, and precious metals can be recycled as material. Plastics, rubber, cardboard and other packaging material can be used in energy recovery.

Printed circuit boards and DC capacitors need selective treatment according to IEC 62635 guidelines.

To aid recycling, most plastic parts are marked with an appropriate identification code. In addition, components containing substances of very high concern (SVHCs) are listed in European Chemicals Agency's SCIP database. SCIP is the database for information on Substances of Concern in articles as such or in complex objects (Products) established under the Waste Framework Directive (2008/98/EC). For further information, contact your local ABB distributor or consult European Chemicals Agency's

---

SCIP database to find out which SVHCs are used in the drive, and to find out where those components are located.

Contact your local ABB distributor for further information on environmental aspects. End of life treatment must follow international and national regulations.

For more information on ABB end of life services, refer to [new.abb.com/service/end-of-life-services](http://new.abb.com/service/end-of-life-services).

## Package dimensions and weights for drives without empty cubicles (without options +C196 ... +C201)

| Frame size | Height | Width | Depth | Standard/Option | Material         | Container type  |
|------------|--------|-------|-------|-----------------|------------------|---|
|            | mm     | mm    | mm    |                 |                  |   |
| R6...R9    | 900    | 820   | 2520  | Standard        | Cardboard        | 20DC <sup>1)</sup>  |
|            |        |       |       | +P912           | Plywood          | 20DC <sup>1)</sup>  |
| R10, R11   | 2550   | 1150  | 1100  | Standard        | Plastic and wood | At least 40HC <sup>2)</sup>                                       |
| R10, R11   | 2550   | 1430  | 1100  | +P912           | Plywood          | At least 40HC <sup>2)</sup><br>Plywood over the normal packaging. |

<sup>1)</sup> All containers are ok, this is the most common.

<sup>2)</sup> Smaller containers do not have sufficient height.

| Frame size | Height | Width | Depth | Standard/Option | Material         | Container type  |
|------------|--------|-------|-------|-----------------|------------------|---|
|            | in     | in    | in    |                 |                  |   |
| R6...R9    | 35.43  | 32.28 | 99.21 | Standard        | Cardboard        | 20DC <sup>1)</sup>  |
|            |        |       |       | +P912           | Plywood          | 20DC <sup>1)</sup>  |
| R10, R11   | 100.39 | 45.27 | 43.30 | Standard        | Plastic and wood | At least 40HC <sup>2)</sup>                                       |
| R10, R11   | 100.39 | 56.30 | 43.30 | +P912           | Plywood          | At least 40HC <sup>2)</sup><br>Plywood over the normal packaging. |

<sup>1)</sup> All containers are ok, this is the most common.

<sup>2)</sup> Smaller containers do not have sufficient height.

### ■ Package weights

| Frame size | Standard |     | +P912 |     |
|------------|----------|-----|-------|-----|
|            | kg       | lb  | kg    | lb  |
| R6         | 220      | 485 | 220   | 485 |
| R7         | 220      | 485 | 220   | 485 |
| R8         | 255      | 562 | 255   | 562 |

| Frame size | Standard |     | +P912 |     |
|------------|----------|-----|-------|-----|
|            | kg       | lb  | kg    | lb  |
| R9         | 275      | 606 | 275   | 606 |
| R10        | 410      | 904 | 440   | 970 |
| R11        | 410      | 904 | 440   | 970 |









## Applicable standards

The drive complies with the standards below. The compliance with the European Low Voltage Directive is verified according to standard EN 61800-5-1.

|   |  |
|---|--|
| EN 61800-5-1:2007   | Adjustable speed electrical power drive systems. Part 5-1: Safety requirements – electrical, thermal and energy  |
| IEC 60146-1-1:2009<br>EN 60146-1-1:2010                     | Semiconductor converters – General requirements and line commutated converters – Part 1-1: Specification of basic requirements   |
| IEC 60204-1:2005<br>+A1:2008<br>EN 60204-1:2006<br>+AC:2010 | Safety of machinery. Electrical equipment of machines. Part 1: General requirements.<br>Provisions for compliance: The final assembler of the machine is responsible for installing emergency-stop device. |
| IEC 60529:1989<br>EN 60529:1991                             | Degrees of protection provided by enclosures (IP code)   |
| IEC/EN 60664-1:2007   | Insulation coordination for equipment within low-voltage systems. Part 1: Principles, requirements and tests   |
| IEC/EN 61439-1:2011   | Low-voltage switchgear and control gear assemblies -- Part 1: General rules  |
| UL 50:2015  | Enclosures for Electrical Equipment, Non-Environmental Considerations, 13th edition  |
| UL 508A:2018  | Standard for Safety, Industrial control panels   |
| UL 508C: 2016   | Standard for Safety, Power Conversion Equipment, fourth edition  |
| CSA C22.2 No. 14-13: 2013                                   | Industrial control equipment   |
| CSA 22.2 No. 274-13: 2013                                   | Adjustable speed drives  |
| IEC 61800-3:2004/A1:2011<br>EN 61800-3/A1:2012              | Adjustable speed electrical power drive systems. Part 3: EMC requirements and specific test methods  |

## Markings

|   |   |
|---|---|
|  | CE mark<br>Product complies with the applicable European Union legislation. For fulfilling the EMC requirements, see the additional information concerning the drive EMC compliance (IEC/EN 61800-3). |
|---|---|

|   |  |
|---|--|
|    | <p>TÜV Safety Approved mark (functional safety)</p> <p>Product contains Safe torque off and possibly other (optional) safety functions which are certified by TÜV according to the relevant functional safety standards. Applicable to drives and inverters; not applicable to supply, brake or DC/DC converter units or modules.</p>  |
|    | <p>UKCA (UK Conformity Assessed) mark</p> <p>Product complies with the applicable United Kingdom's legislation (Statutory Instruments). Marking is required for products being placed on the market in Great Britain (England, Wales and Scotland).</p>  |
|    | <p>UL Listed mark for USA and Canada</p> <p>Product has been tested and evaluated against the relevant North American standards by the Underwriters Laboratories. Valid with rated voltages up to 600 V.</p>   |
|    | <p>RCM mark</p> <p>Product complies with Australian and New Zealand requirements specific to EMC, telecommunications and electrical safety. For fulfilling the EMC requirements, see the additional information concerning the drive EMC compliance (IEC/EN 61800-3).</p>  |
|   | <p>EAC (Eurasian Conformity) mark</p> <p>Product complies with the technical regulations of the Eurasian Customs Union. EAC mark is required in Russia, Belarus and Kazakhstan.</p>  |
|  | <p>Electronic Information Products (EIP) symbol including an Environment Friendly Use Period (EFUP).</p> <p>Product is compliant with the People's Republic of China Electronic Industry Standard (SJ/T 11364-2014) about hazardous substances. The EFUP is 20 years. China RoHS II Declaration of Conformity is available from <a href="https://library.abb.com">https://library.abb.com</a>.</p> |
|  | <p>CMIM mark</p> <p>Product complies with Morocco's safety standard for marketing of toys and electrical products.</p>   |
|  | <p>BTL (BACnet Testing Laboratories) mark</p> <p>Product has BACnet conformance certificate.</p>   |
|  | <p>WEEE mark</p> <p>At the end of life the product should enter the recycling system at an appropriate collection point and not placed in the normal waste stream.</p>   |

## CE marking

A CE mark is attached to the drive to verify that the drive complies with the provisions of the European Low Voltage and EMC Directives. The CE marking also verifies that the drive, in regard to its safety functions (such as Safe torque off), conforms with the Machinery Directive as a safety component.



### ■ Compliance with the European Low Voltage Directive

The compliance with the European Low Voltage Directive has been verified according to standard EN 61800-5-1.

### ■ Compliance with the European EMC Directive

The EMC Directive defines the requirements for immunity and emissions of electrical equipment used within the European Union. The EMC product standard (EN 61800-3:2004) covers requirements stated for drives. See section [Compliance with the EN 61800-3:2004](#) below.

### ■ Compliance with the European Machinery Directive

The drive is an electronic product which is covered by the European Low Voltage Directive. However, the drive includes the Safe torque off function and can be equipped with other safety functions for machinery which, as safety components, are in the scope of the Machinery Directive. These functions of the drive comply with European harmonized standards such as EN 61800-5-2. For the declaration of conformity, see chapter [The Safe torque off function \(page 269\)](#).

### ■ Compliance with the EN 61800-3:2004

#### Definitions

EMC stands for Electromagnetic Compatibility. It is the ability of electrical/electronic equipment to operate without problems within an electromagnetic environment. Likewise, the equipment must not disturb or interfere with any other product or system within its locality.

First environment includes establishments connected to a low-voltage network which supplies buildings used for domestic purposes.

Second environment includes establishments connected to a network not supplying domestic premises.

Drive of category C1: drive of rated voltage less than 1000 V and intended for use in the first environment.

Drive of category C2: drive of rated voltage less than 1000 V and intended to be installed and started up only by a professional when used in the first environment.

**Note:** A professional is a person or organization having necessary skills in installing and/or starting up power drive systems, including their EMC aspects.

Drive of category C3: drive of rated voltage less than 1000 V and intended for use in the second environment and not intended for use in the first environment.

Drive of category C4: drive of rated voltage equal to or above 1000 V, or rated current equal to or above 400 A, or intended for use in complex systems in the second environment.

#### Category C2

The drive frames R6 to R9 comply with the standard with the following provisions:

1. The drive is equipped with EMC filter option +E202.
2. The motor and control cables are selected as specified in the hardware manual.

3. The drive is installed according to the instructions given in the hardware manual.
  4. Maximum motor cable length is 100 meters.
- 



**WARNING!**

The drive may cause radio interference if used in a residential or domestic environment. The user is required to take measures to prevent interference, in addition to the requirements for CE compliance listed above, if necessary.

---

**Note:** Do not install a drive equipped with EMC filter on IT (ungrounded) systems. The supply network becomes connected to ground potential through the EMC filter capacitors which may cause danger or damage the unit.

**Category C3**

The drive complies with the standard with the following provisions:

1. The motor and control cables are selected as specified in the hardware manual.
  2. The drive is installed according to the instructions given in the hardware manual.
  3. Maximum motor cable length is 100 meters.
- 



**WARNING!**

A drive of category C3 is not intended to be used on a low-voltage public network which supplies domestic premises. Radio frequency interference is expected if the drive is used on such a network.

---

**Category C4**

The drive complies with the C4 category with these provisions:

1. It is made sure that no excessive emission is propagated to neighboring low-voltage networks. In some cases, the natural suppression in transformers and cables is sufficient. If in doubt, a supply transformer with static screening between the primary and secondary windings can be used.
-

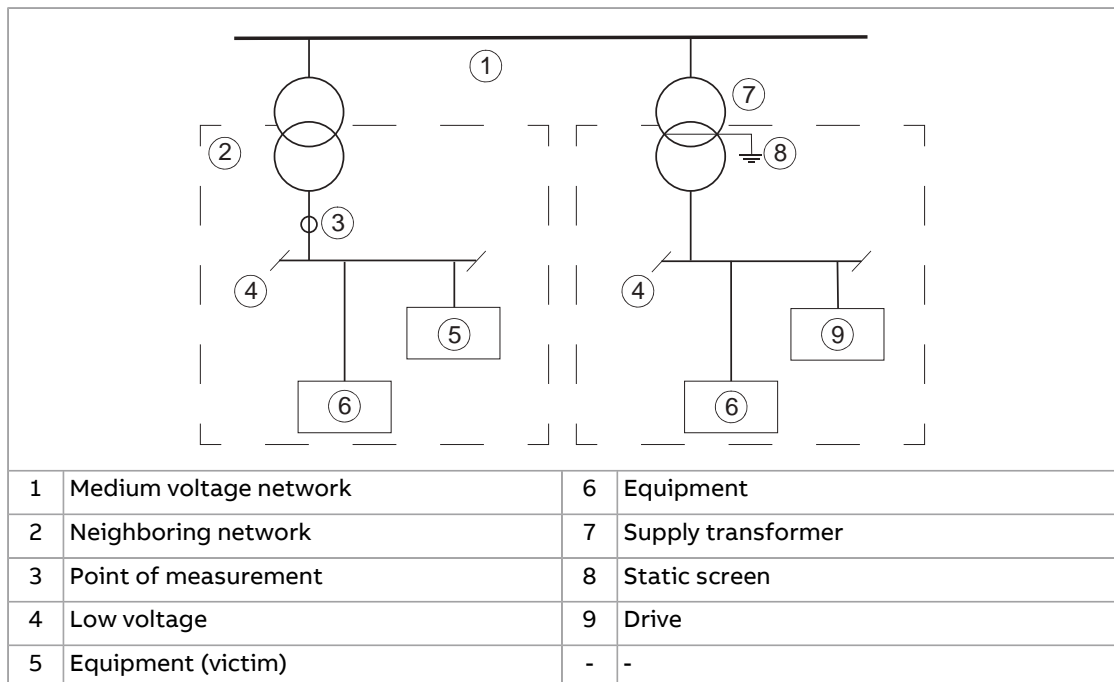

2. An EMC plan for preventing disturbances is drawn up for the installation. A template is available in [Technical guide No. 3 EMC compliant installation and configuration for a power drive system \(3AFE61348280 \[English\]\)](#).
3. The motor and control cables are selected, and routed according to the electrical planning guidelines of the drive. The EMC recommendations are obeyed.
4. The drive is installed according to its installation instructions. The EMC recommendations are obeyed.



**WARNING!**

A drive of category C4 is not intended to be used on a low-voltage public network which supplies domestic premises. Radio frequency interference is expected if the drive is used on such a network.

## UL marking

The drive is cULus listed with option +C129. The approval is valid with rated voltages up to 480 V.

### ■ UL checklist



**WARNING!**

Operation of this drive requires detailed installation and operation instructions provided in the hardware and software manuals. The manuals are provided in electronic format in the drive package or on the Internet. Keep the manuals with the drive at all times. Hard copies of the manuals can be ordered through the manufacturer.

- Make sure that the drive type designation label includes the applicable marking.
- **DANGER - Risk of electric shock.** After disconnecting the input power, always wait for 5 minutes to let the intermediate circuit capacitors discharge before you start working on the drive, motor or motor cable.
- The drive is to be used in a heated, indoor controlled environment. The drive must be installed in clean air according to the enclosure classification. Cooling air must be clean, free from corrosive materials and electrically conductive dust.
- For UL and CSA compliant installations, the maximum surrounding air temperature is 40 °C (104 °F).
- The drive is suitable for use in a circuit capable of delivering not more than 100 kA rms symmetrical amperes, 480 V maximum when protected by the UL fuses given elsewhere in this chapter. The ampere rating is based on tests done according to the appropriate UL standard.
- The cables located within the motor circuit must be rated for at least 75 °C in UL-compliant installations.
- The input cable must be protected with fuses or circuit breakers. These protective devices provide branch circuit protection in accordance with the national regulations (National Electrical Code (NEC) or Canadian Electrical Code). Obey also any other applicable local or provincial codes.



**WARNING!**

The opening of the branch-circuit protective device may be an indication that a fault current has been interrupted. To reduce the risk of fire or electric shock, current-carrying parts and other components of the device should be examined and replaced if damaged.

---

- The drive is equipped with UL listed fuses which provide branch circuit protection in accordance with the National Electrical Code (NEC) and Canadian Electrical Code.  
The fuses are listed elsewhere in this chapter.
- The drive provides motor overload protection. For adjustments, see the firmware manual.
- The drive overvoltage category according to IEC 60664-1 is III, except for auxiliary power connections (fan, control, heating, lighting, cooling unit pump etc) which are of category II.

## Design lifetime expectancy

The design lifetime expectancy of the drive and its overall components exceeds ten (10) years in normal operating environments. In some cases, the drive can last 20 years or more. To achieve a long lifetime for the product the manufacturer's instructions for sizing the drive, installation, operational conditions and preventive maintenance schedule shall be followed.

---

## Disclaimers

### ■ Generic disclaimer

The manufacturer shall have no obligation with respect to any product which (i) has been improperly repaired or altered; (ii) has been subjected to misuse, negligence or accident; (iii) has been used in a manner contrary to the manufacturer's instructions; or (iv) has failed as a result of ordinary wear and tear.

### ■ Cyber security disclaimer

This product is designed to be connected to and to communicate information and data via a network interface. It is Customer's sole responsibility to provide and continuously ensure a secure connection between the product and Customer network or any other network (as the case may be). Customer shall establish and maintain any appropriate measures (such as but not limited to the installation of firewalls, application of authentication measures, encryption of data, installation of anti-virus programs, etc.) to protect the product, the network, its system and the interface against any kind of security breaches, unauthorized access, interference, intrusion, leakage and/or theft of data or information.

ABB and its affiliates are not liable for damages and/or losses related to such security breaches, any unauthorized access, interference, intrusion, leakage and/or theft of data or information.

---

## Declarations of conformity



[Link to Declaration of conformity according to EU Machinery Directive 2006/42/EU \(3AXD10000675693\)](#)



[Link to Declaration of conformity according to UK Supply of Machinery \(Safety\) Regulations 2008 \(3AXD10001329523\)](#)



[Link to Declaration of China RoHS II conformity \(3AXD10001497382\)](#)

---



13

## Dimension drawings

---

Example dimension drawings are shown below.

---

# Frames R6 and R7 (+B052: IP21, UL Type 1)

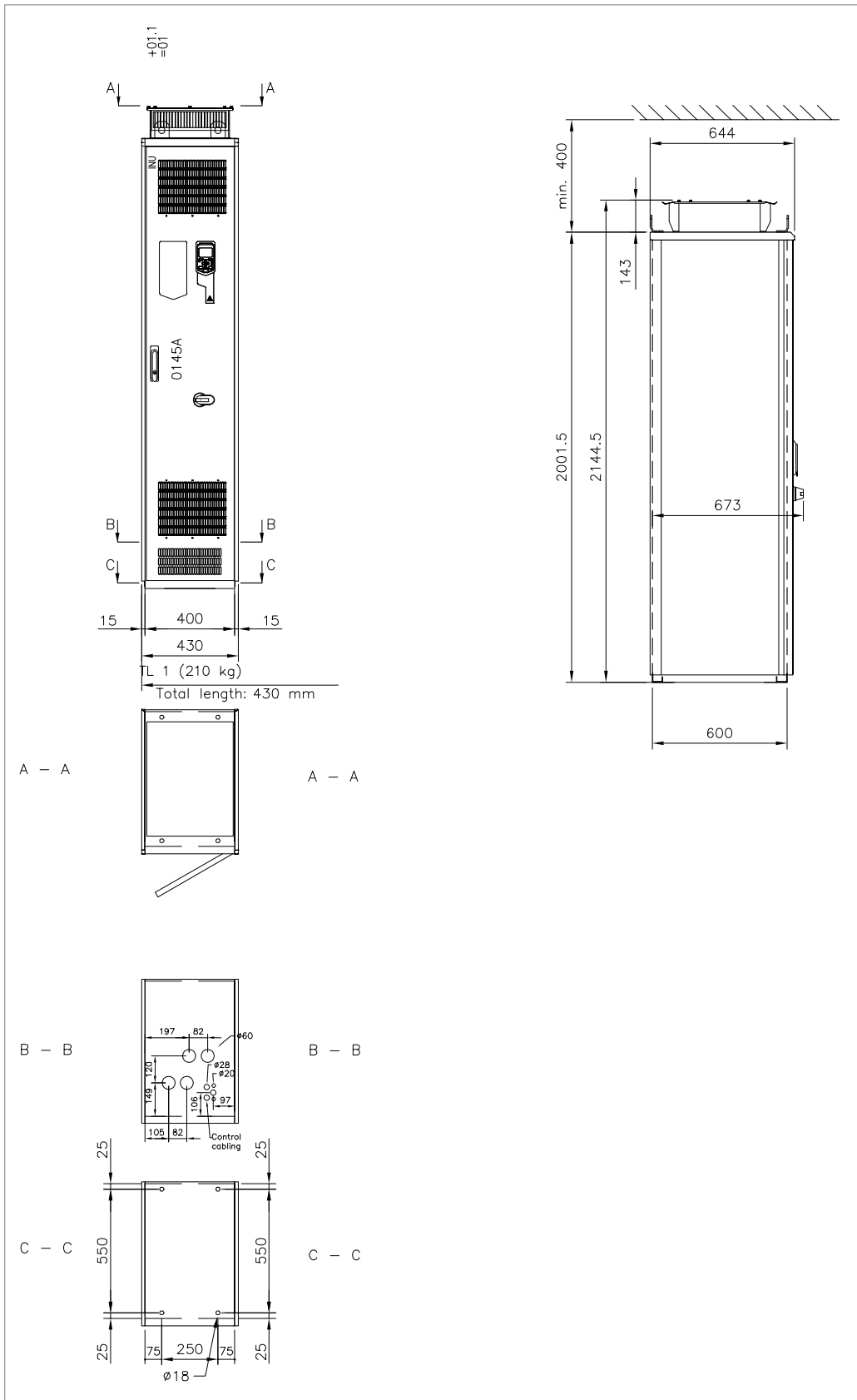



# Frames R6 and R7 (+B054: IP42, UL Type 1 Filtered)

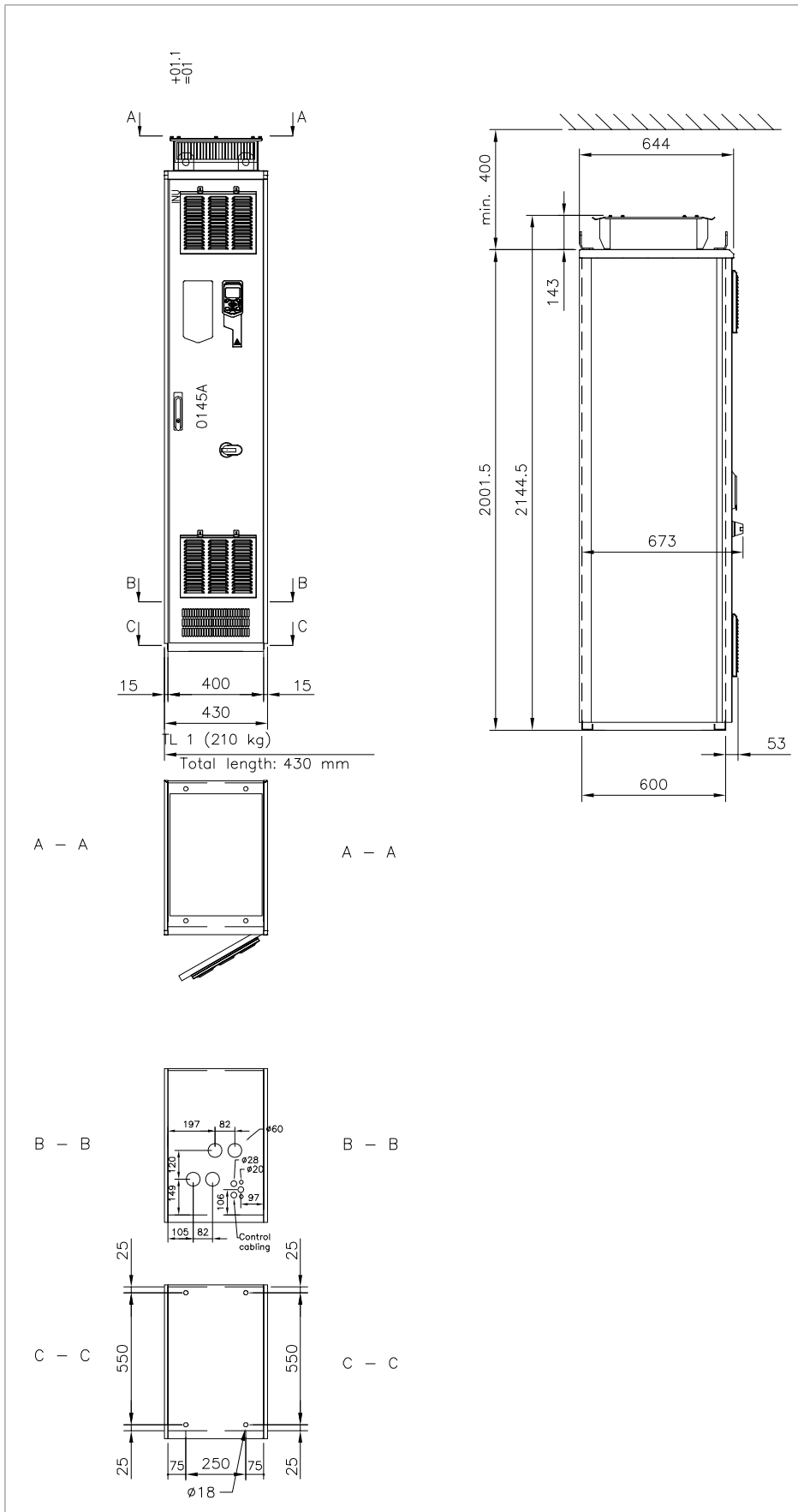

# Frames R6 and R7 (+B055: IP54, UL Type 12)

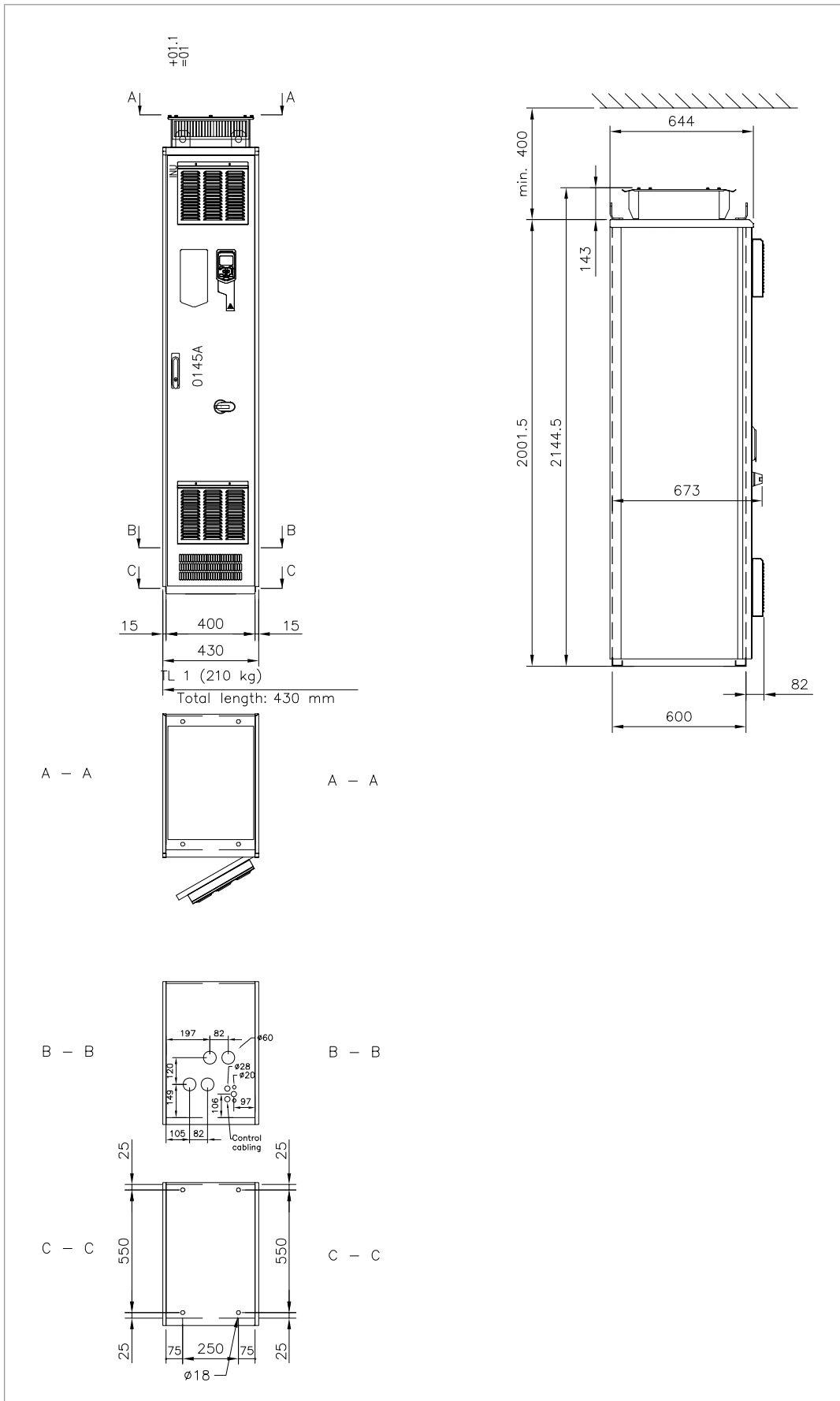

### Frames R6 and R7 (+H351 and +H353: top entry and exit)

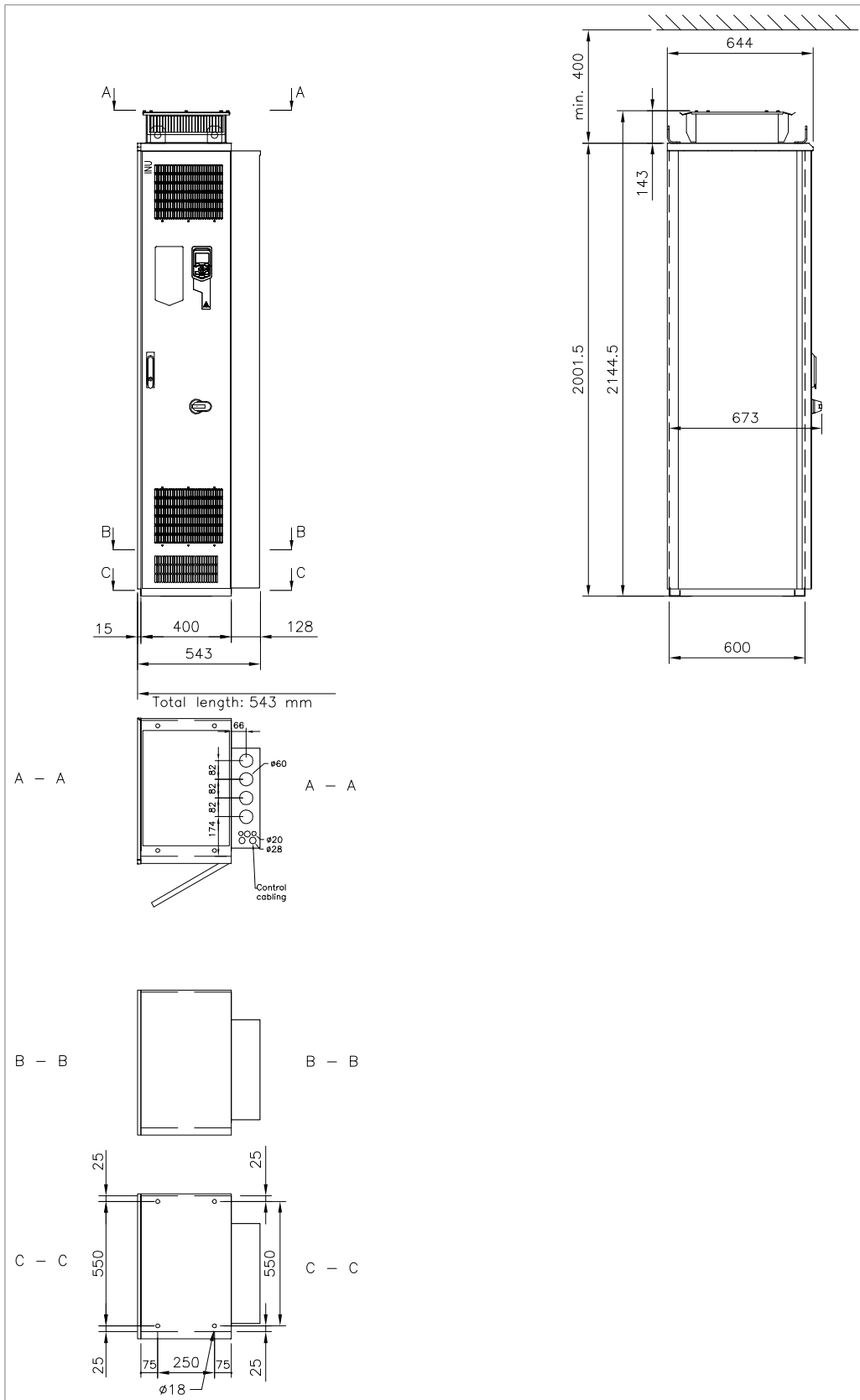

# Frames R6 and R7 (+F289)

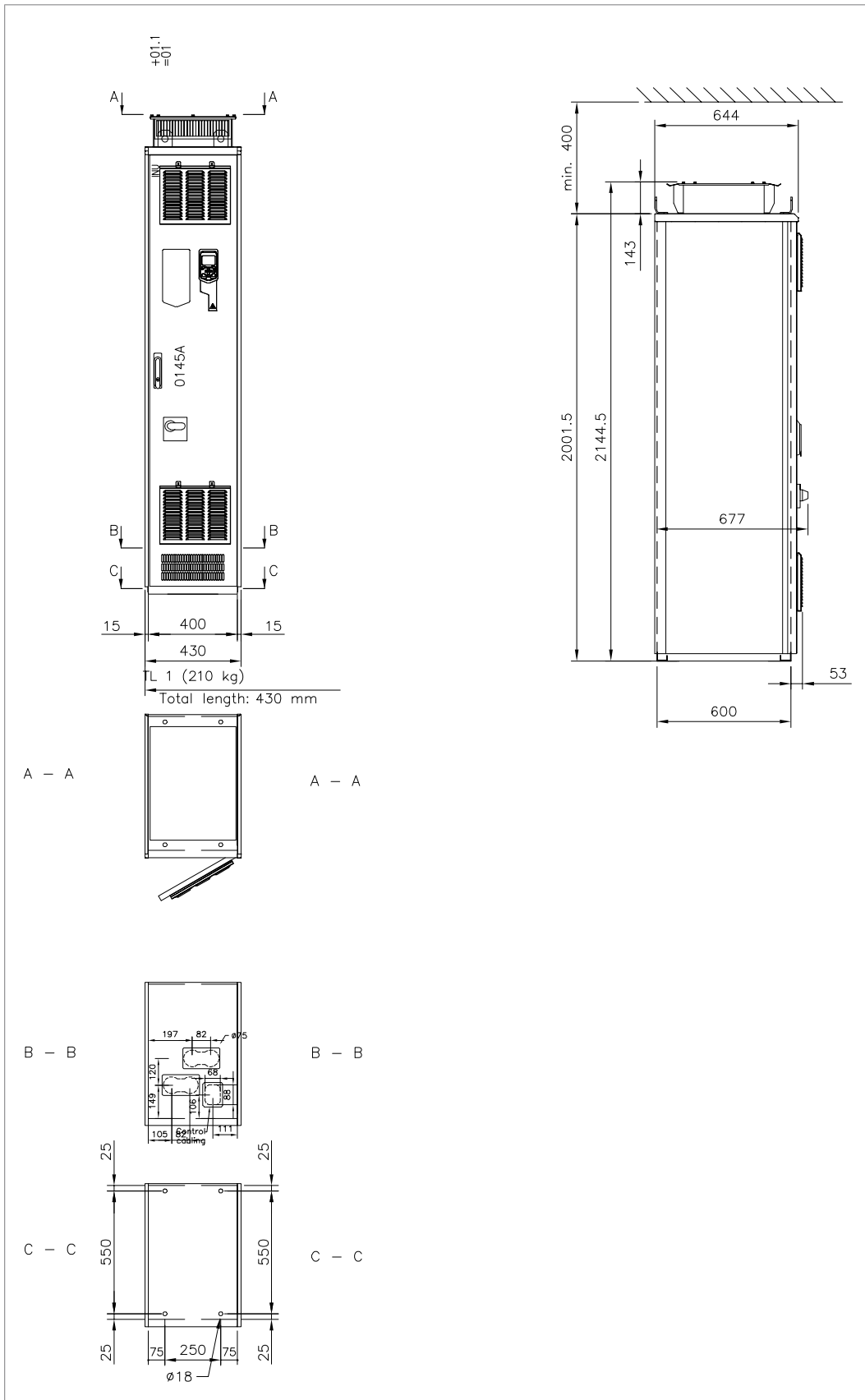

### Frames R6 and R7 (+F289, +H351, +H353)

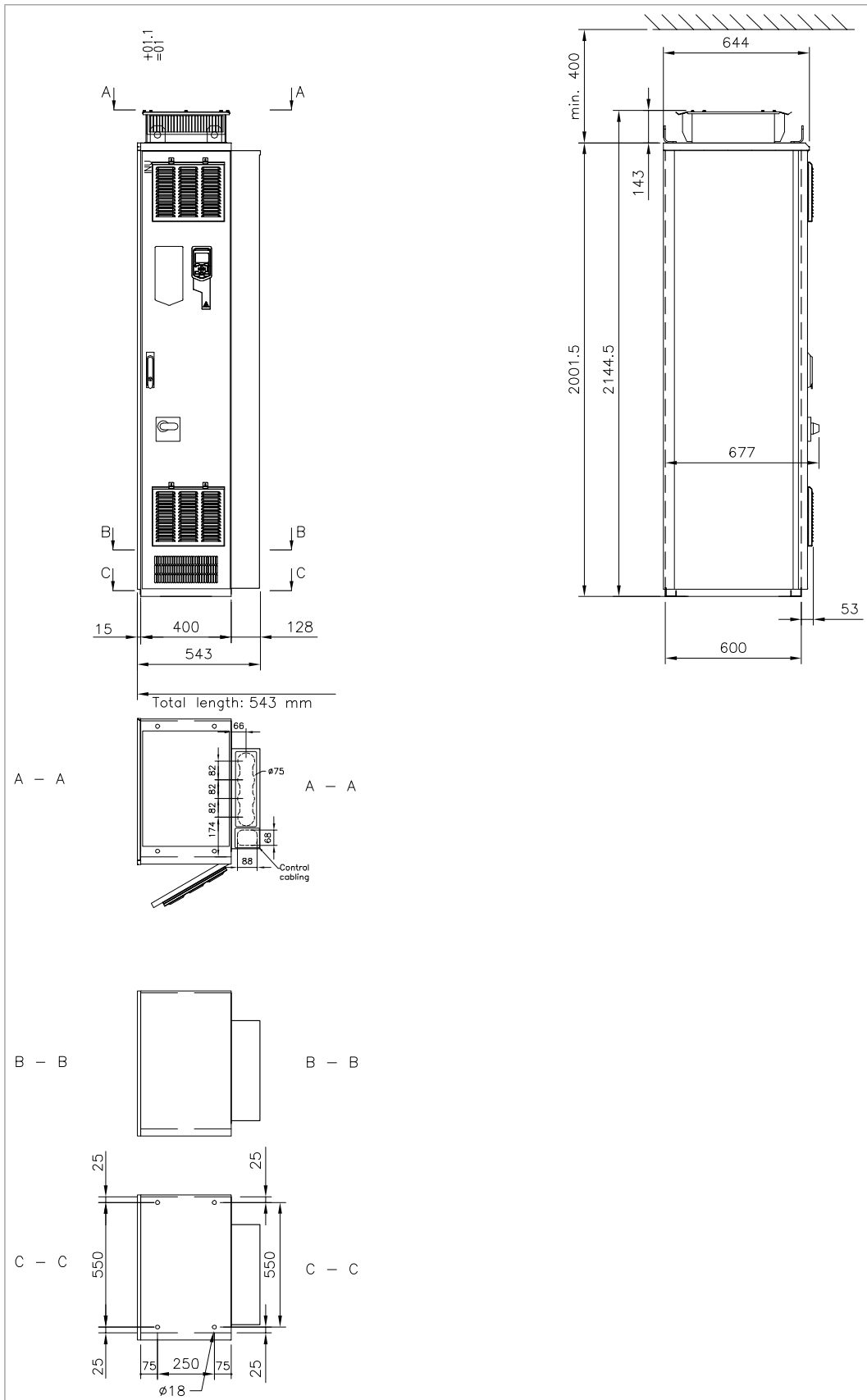

# Frames R8 and R9 (IP21, UL Type 1)

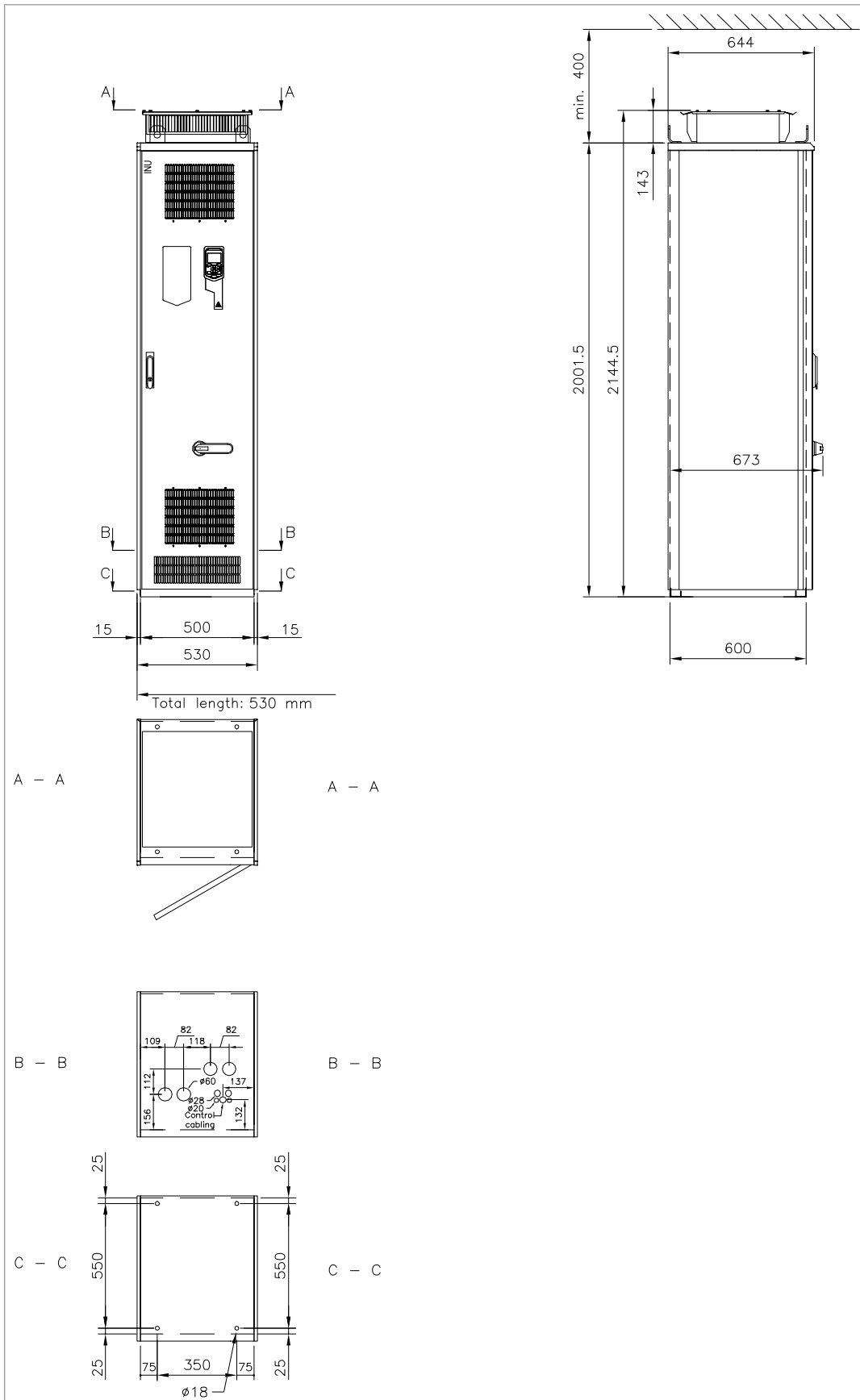

### Frames R8 and R9 (+B054: IP42, UL Type 1 Filtered)

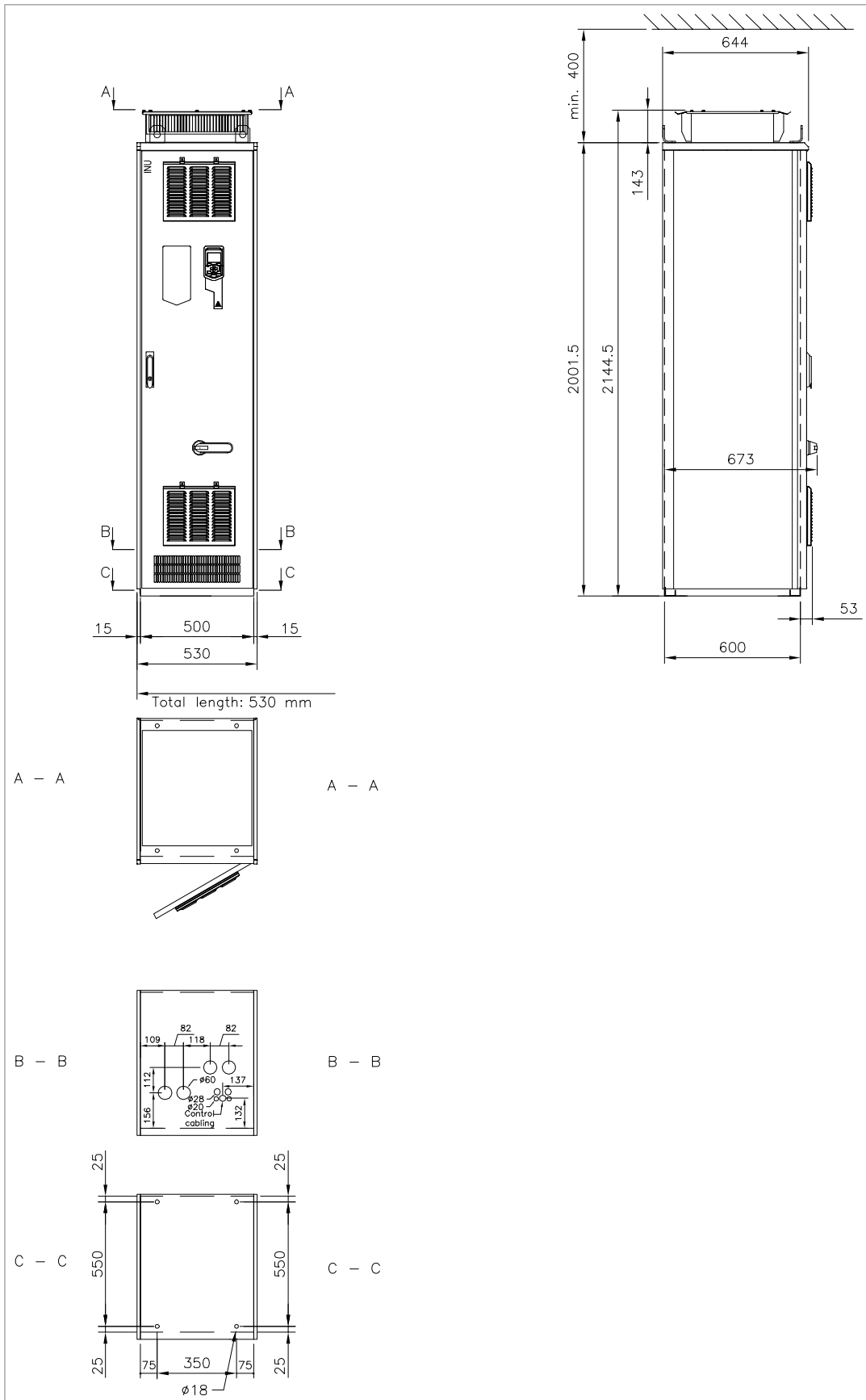

## Frames R8 and R9 (+B055: IP54, UL Type 12)

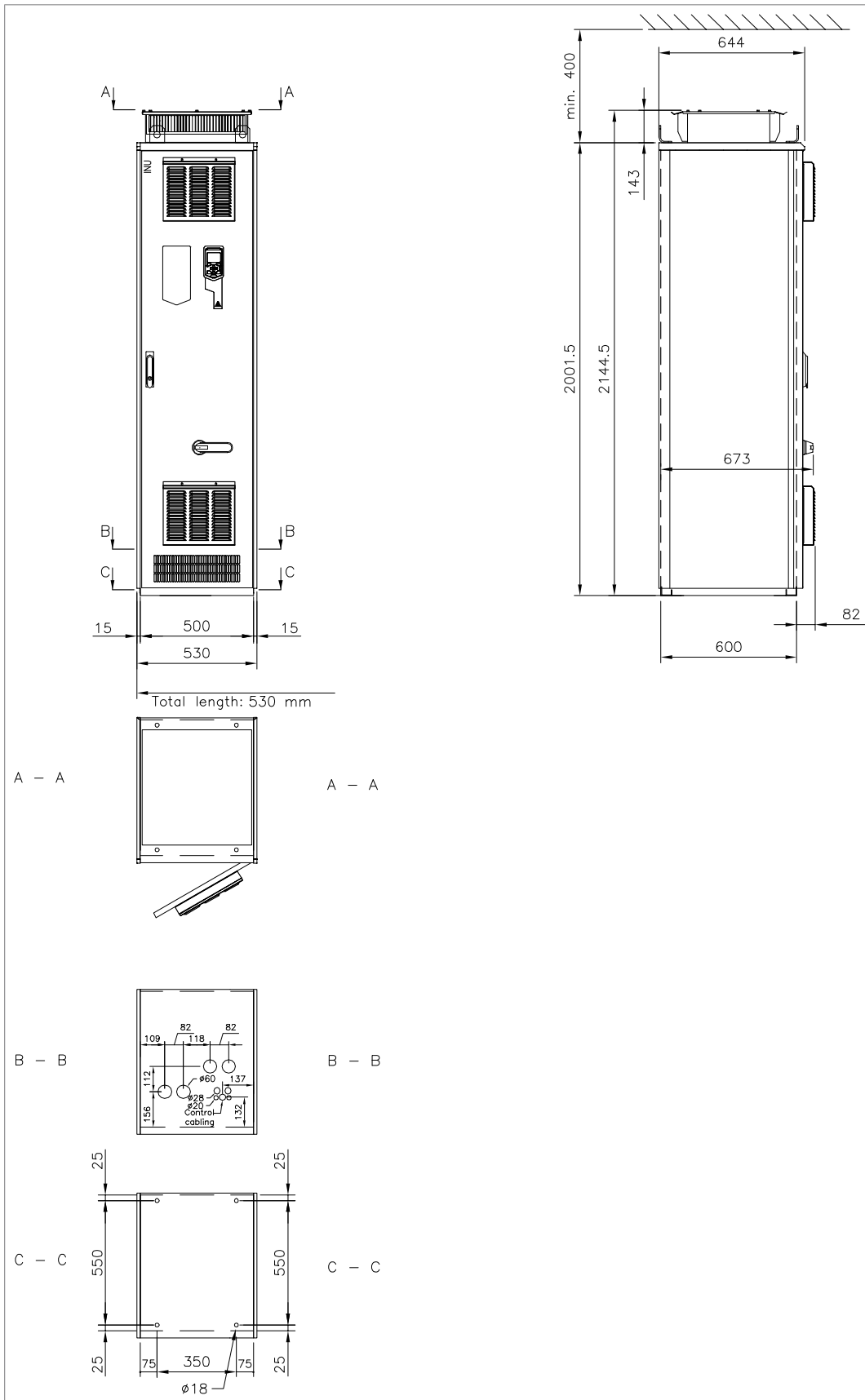



### Frames R8 and R9 (+H351 and +H353: top entry and exit)

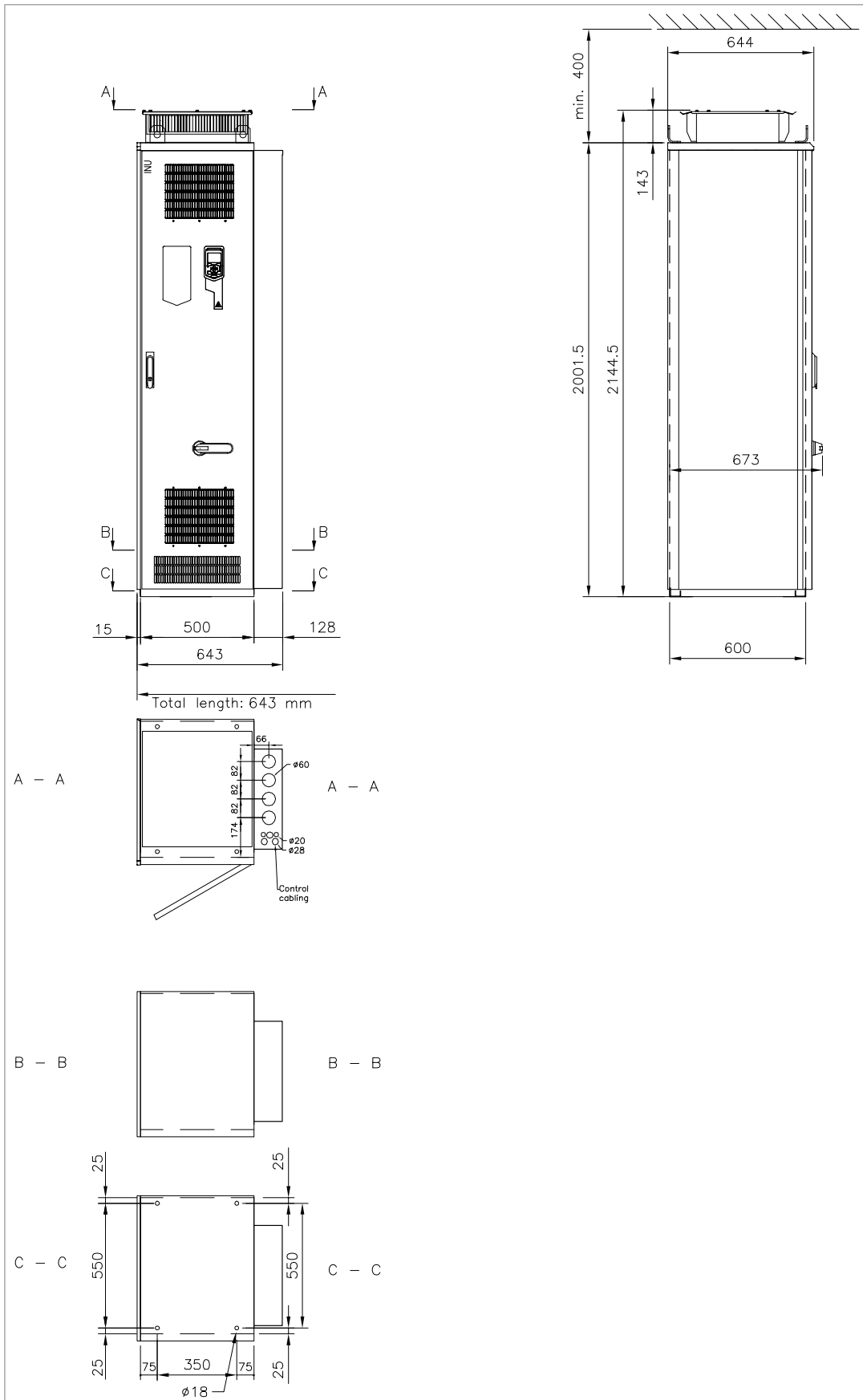

# Frames R8 and R9 (+F289)

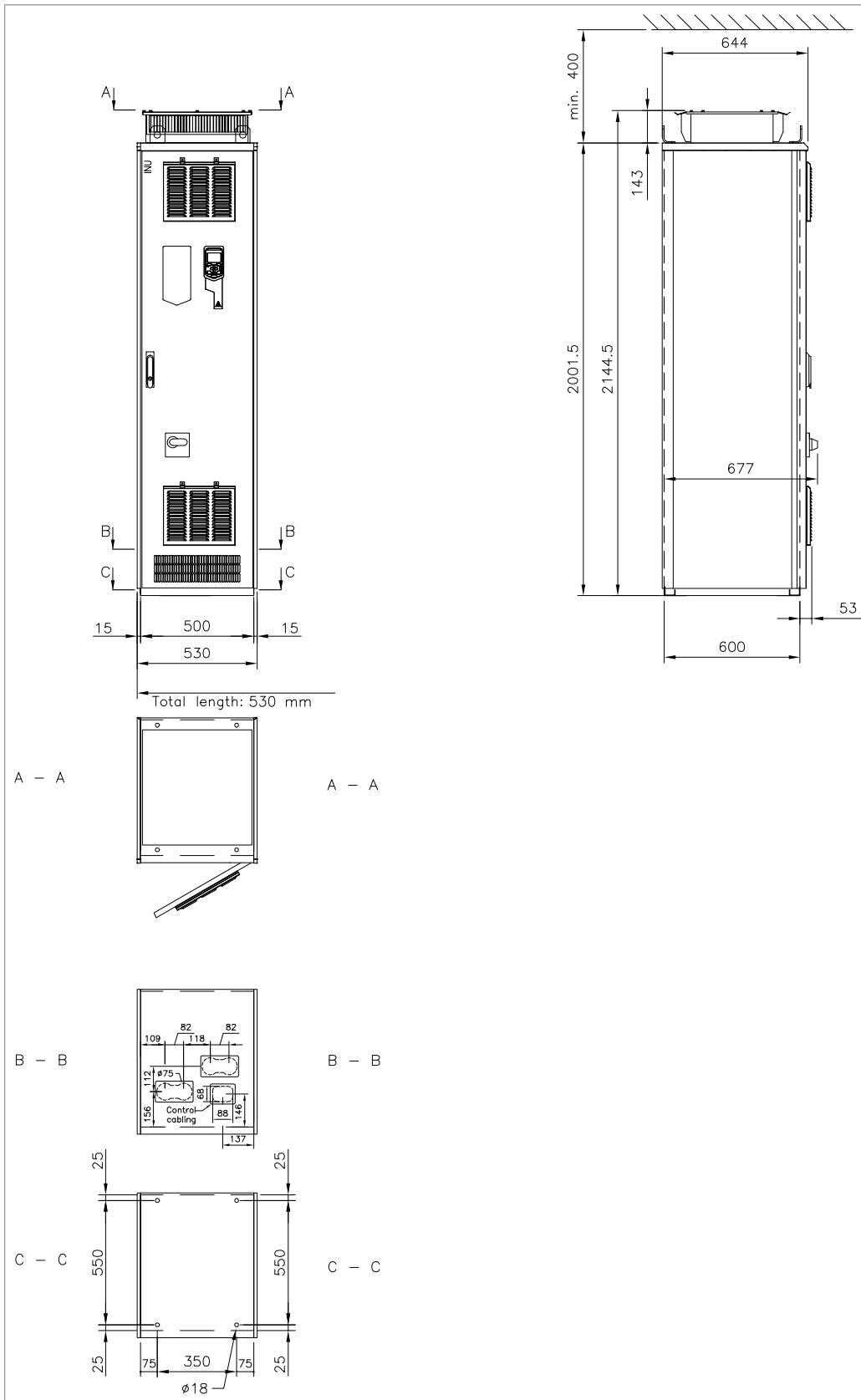

### Frames R8 and R9 (+F289, +H351, +H353)

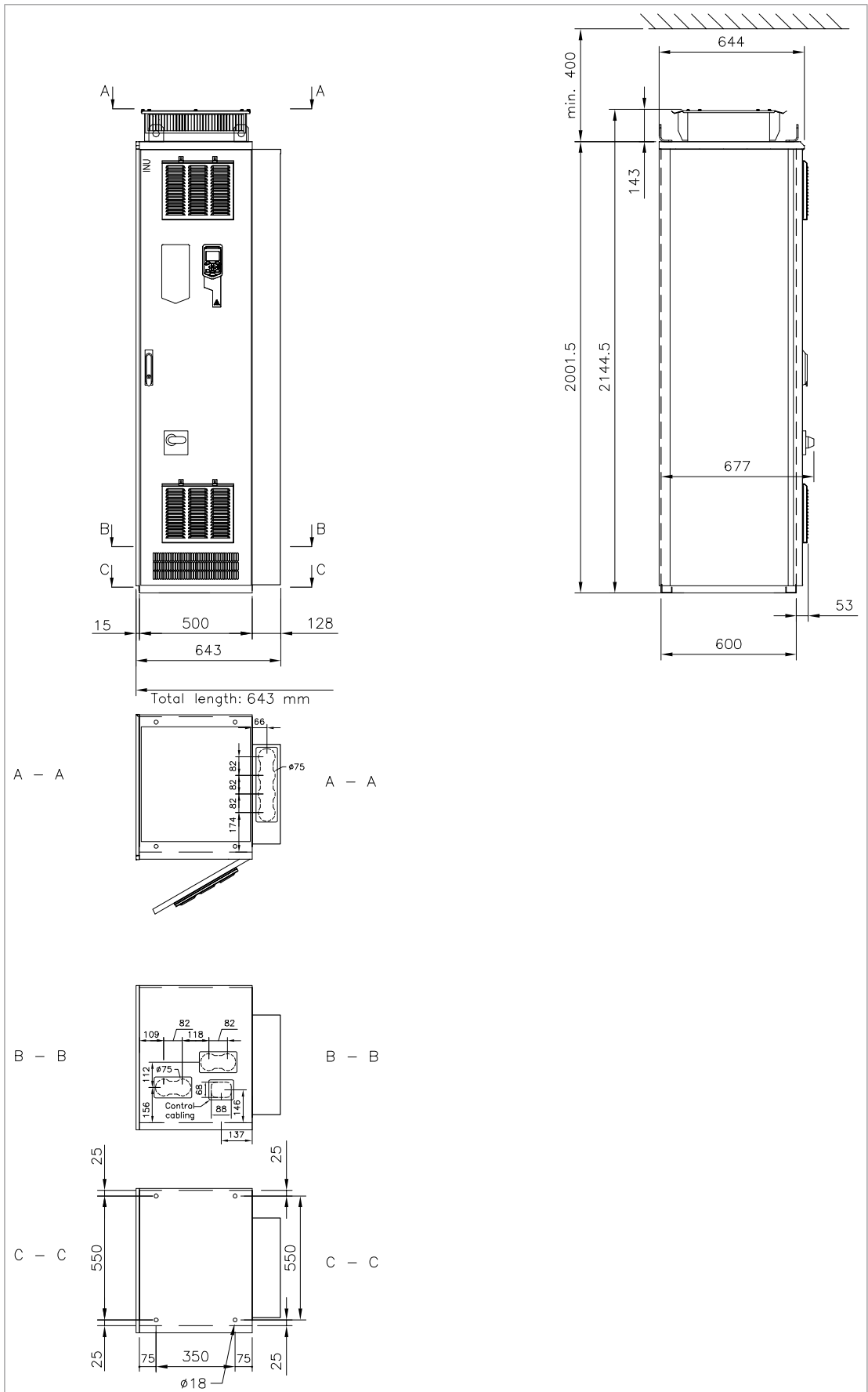

## Frames R10 and R11 (IP21, UL Type 1)

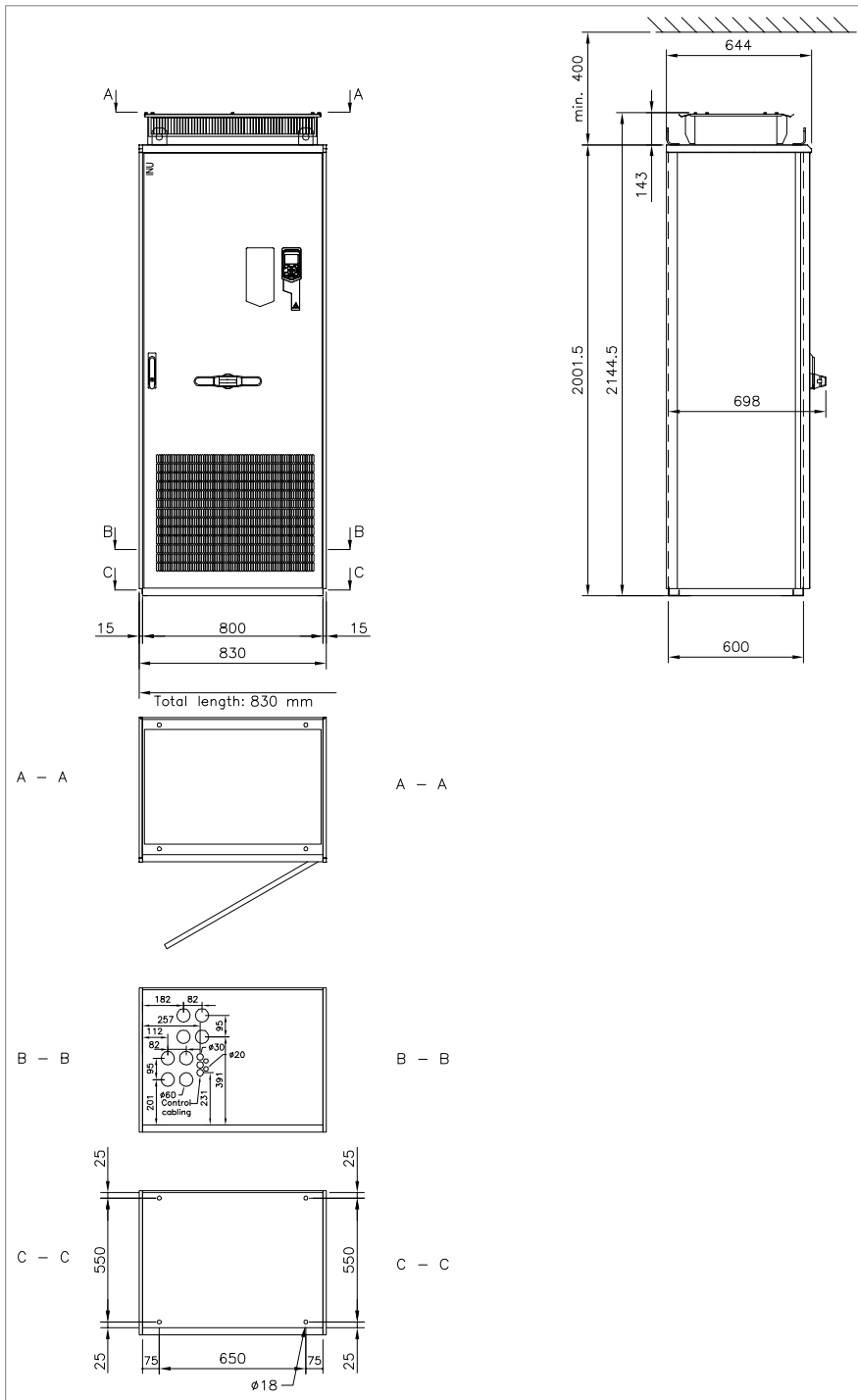

## Frames R10 and R11 (+B054: IP42, UL Type 1 Filtered)

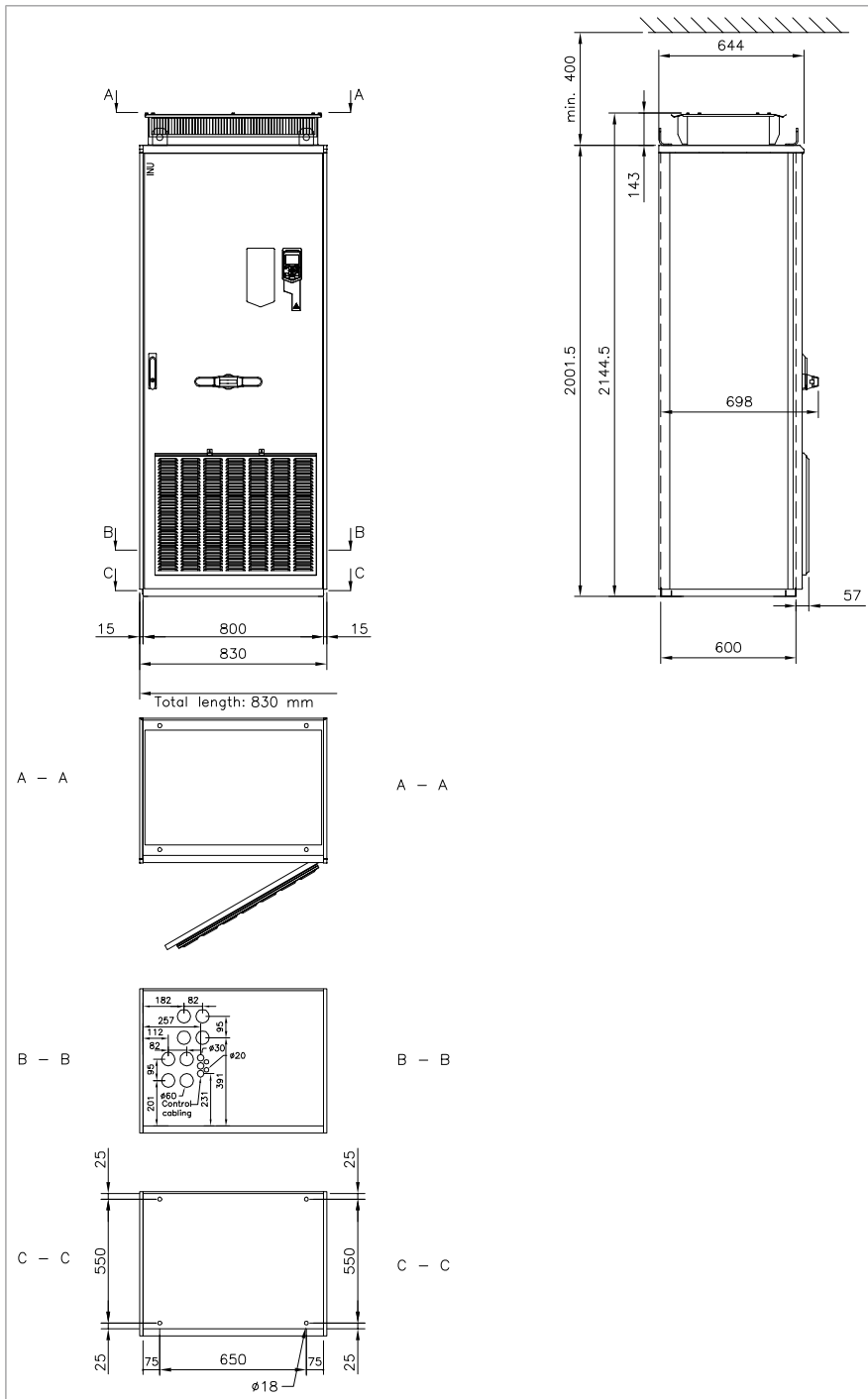

# Frames R10 and R11 (+B055: IP54, UL Type 12)

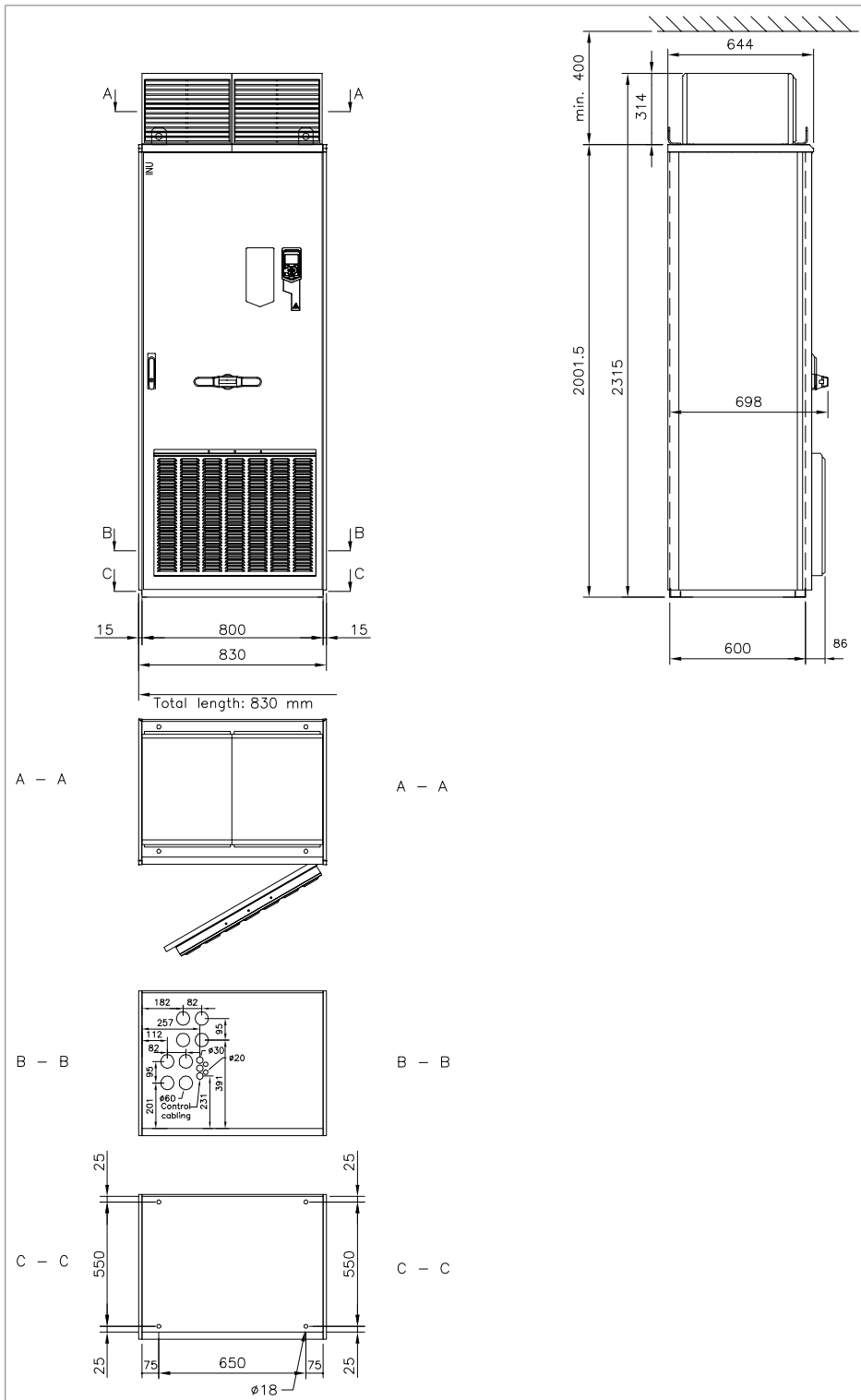

# Frames R10 and R11 (+F289)

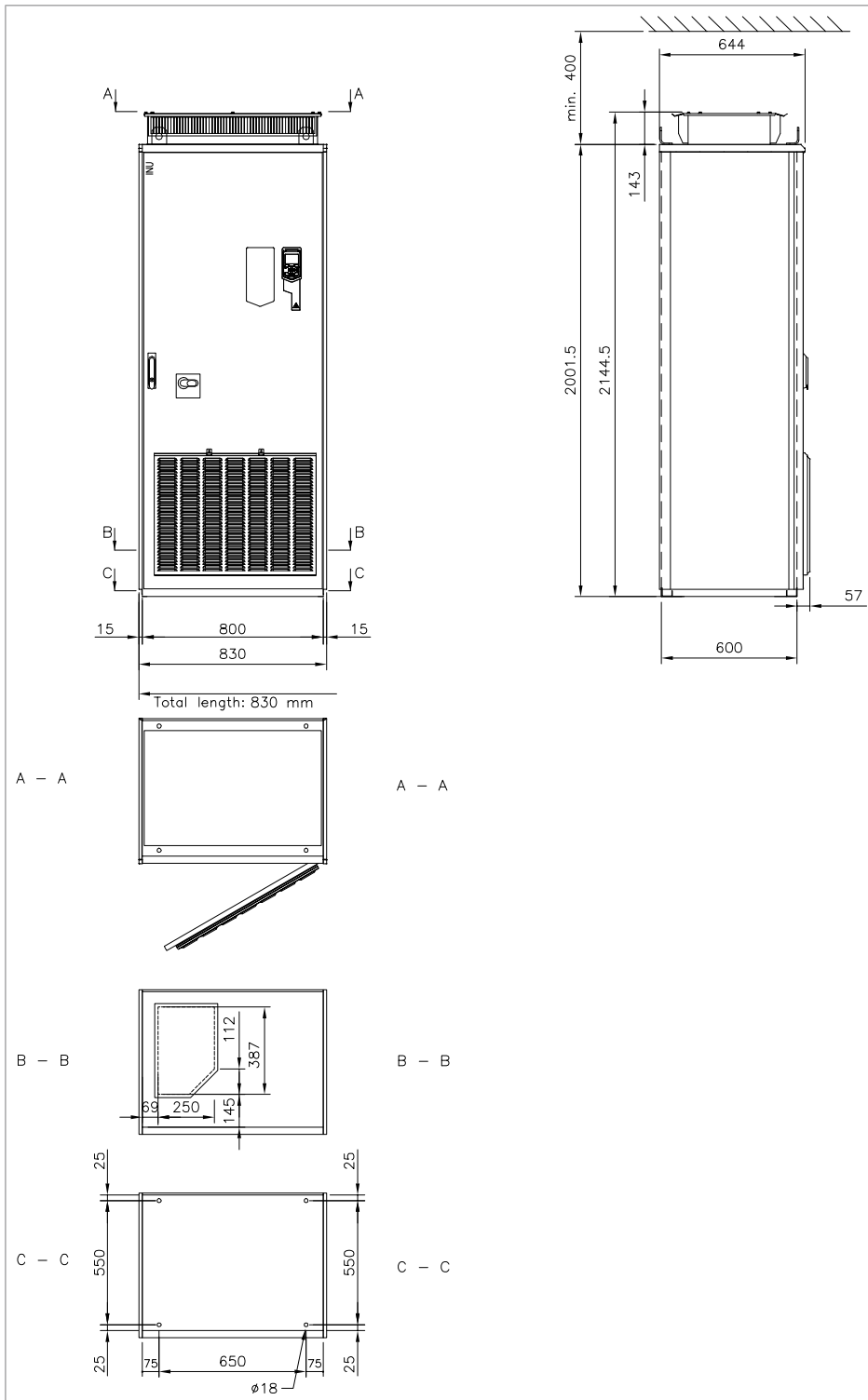

# Frames R10 and R11 (+H351, +H353)

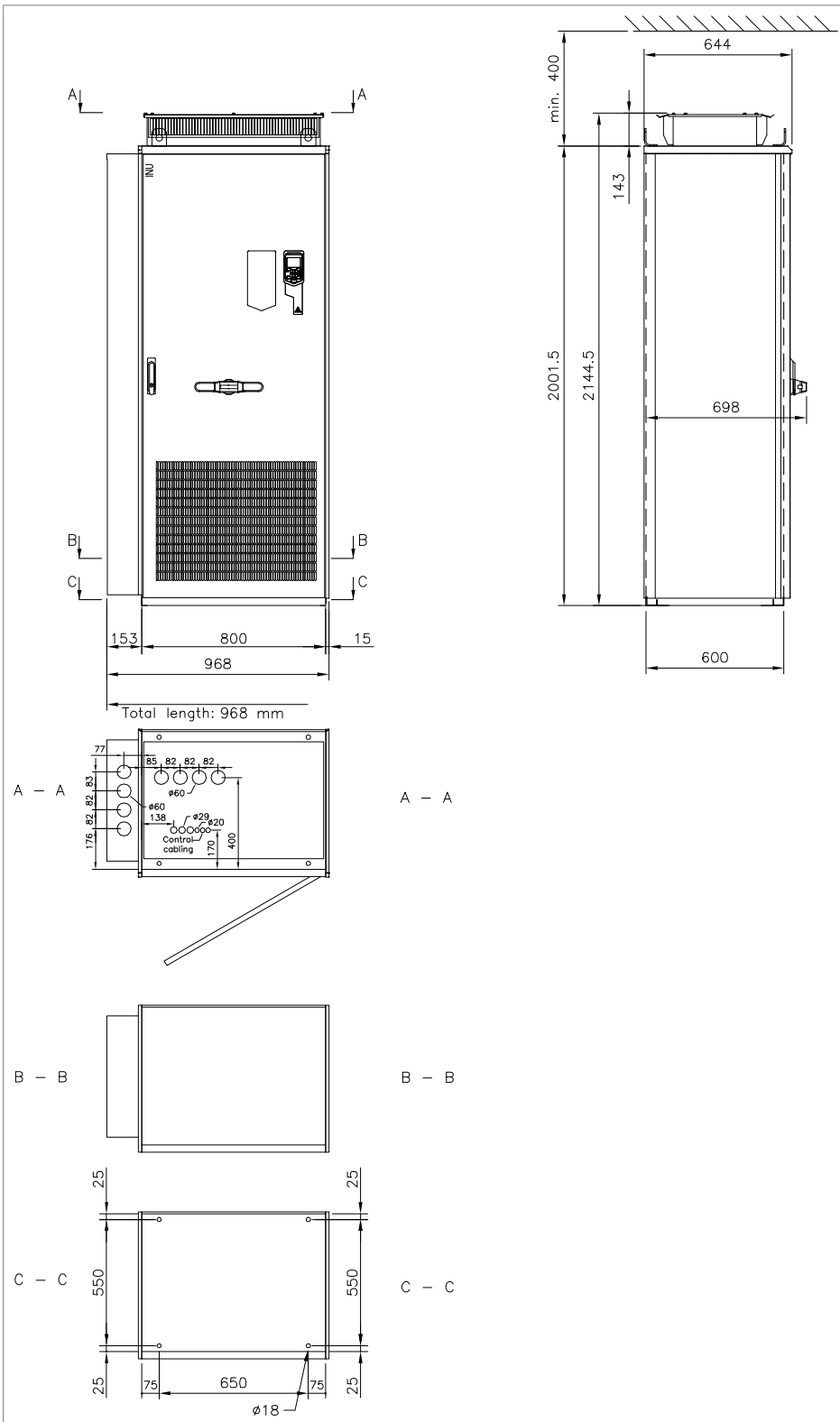



# Frames R10 and R11 (+B054: IP42, UL type 1 filtered, +H351, +H353)

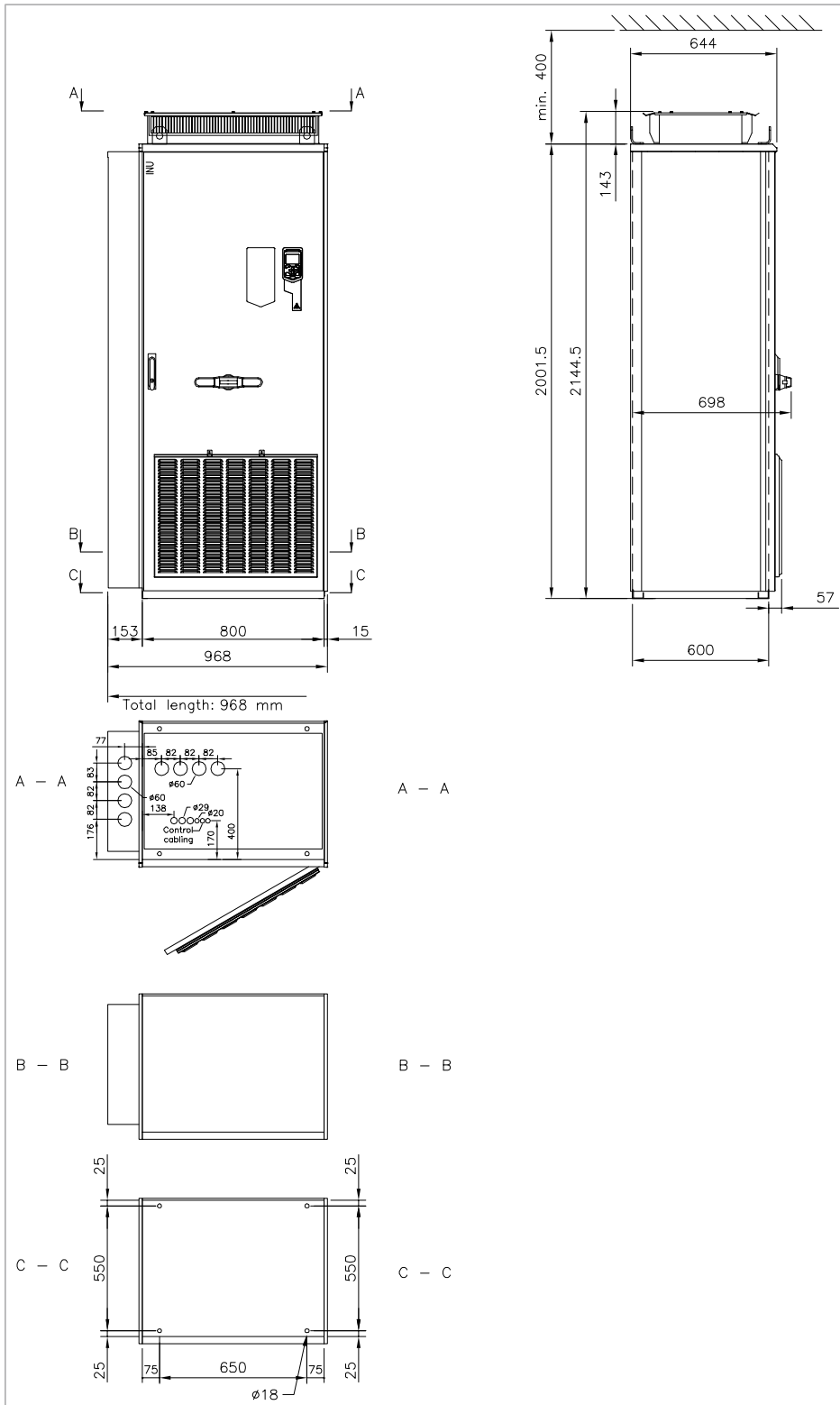

# Frames R10 and R11 (+B055: IP54, UL type 12, +H351, +H353)

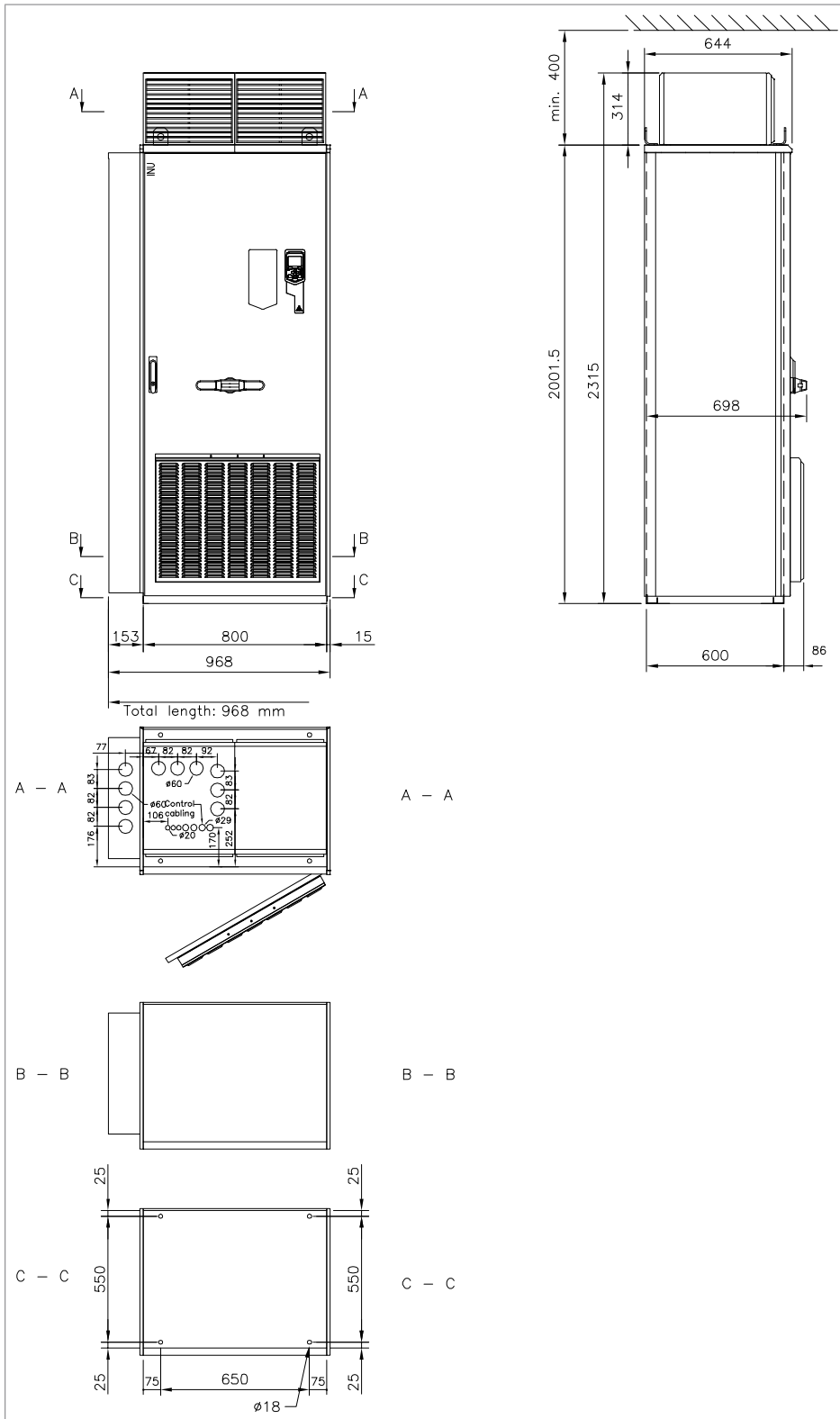

# Dimensions of empty cubicles (options +C196...+C201)

## ■ IP22/IP42

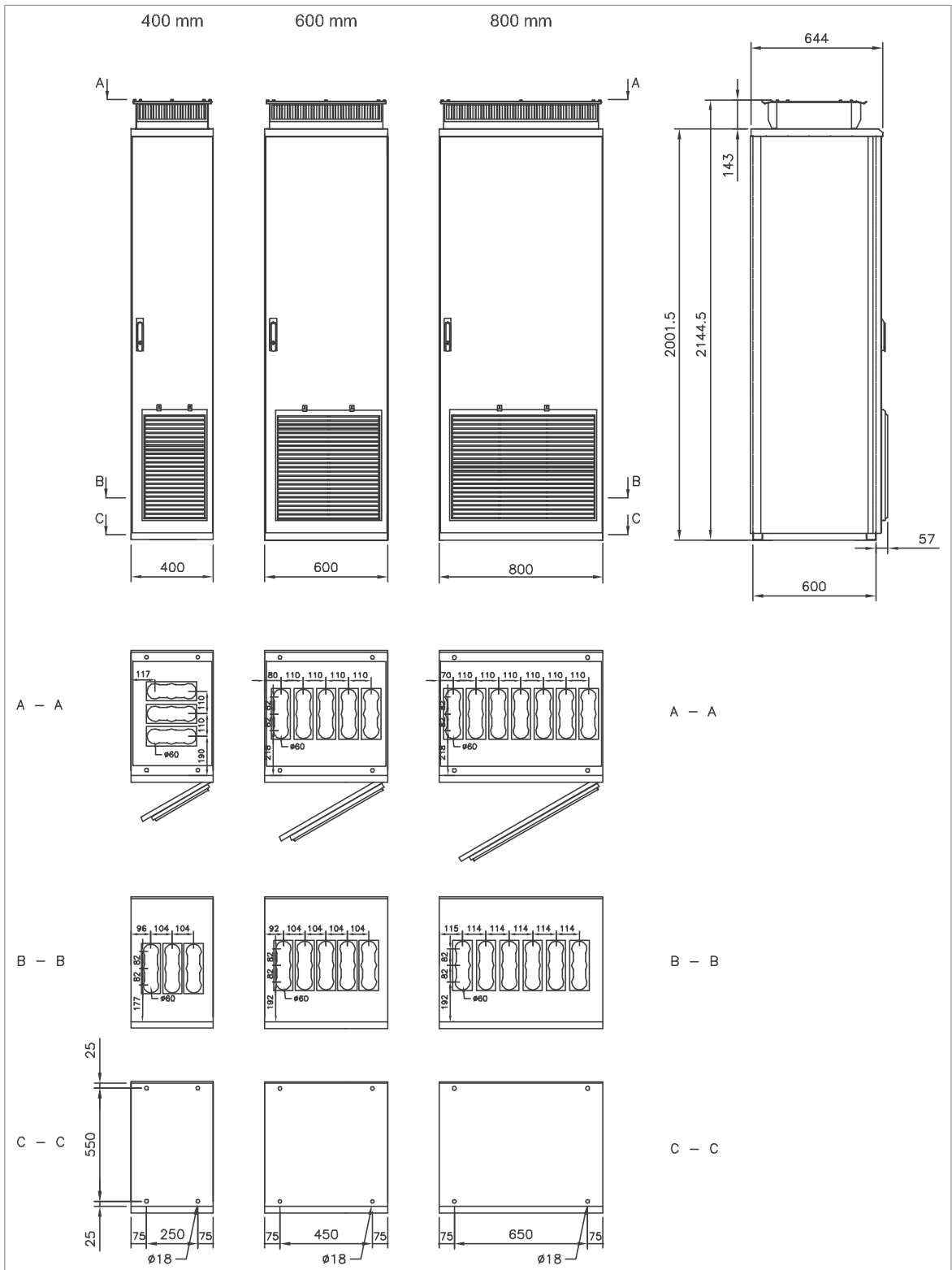

■ IP54

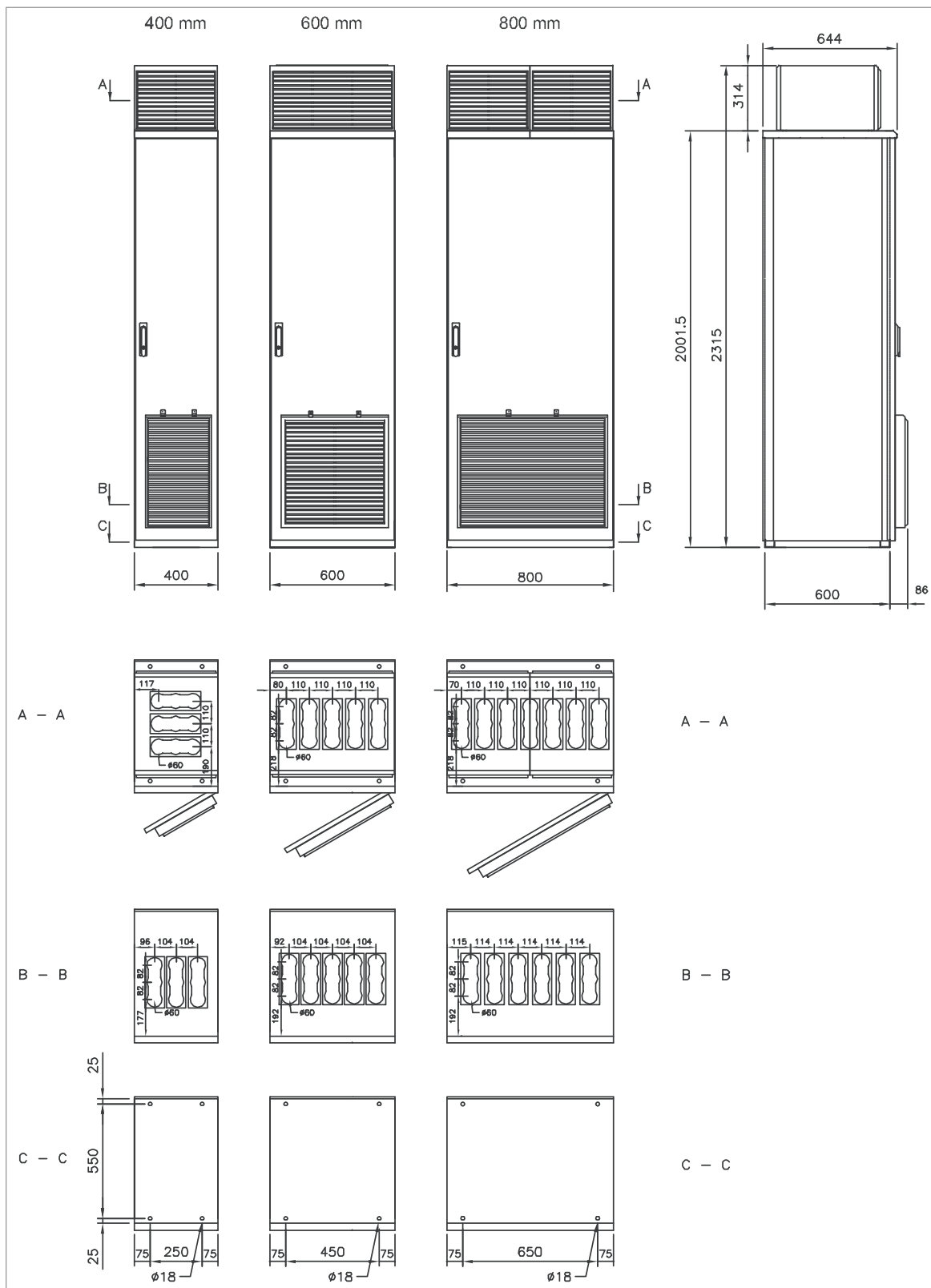

# 14

## The Safe torque off function

---

### Contents of this chapter

This chapter describes the Safe torque off (STO) function of the drive and gives instructions for its use.

### Description

The Safe torque off function can be used, for example, as the final actuator device of safety circuits (such as an emergency stop circuit) that stop the drive in case of danger. Another typical application is a prevention of unexpected start-up function that enables short-time maintenance operations like cleaning or work on non-electrical parts of the machinery without switching off the power supply to the drive.

When activated, the Safe torque off function disables the control voltage for the power semiconductors of the drive output stage, thus preventing the drive from generating the torque required to rotate the motor. If the motor is running when Safe torque off is activated, it coasts to a stop.

The Safe torque off function has a redundant architecture, that is, both channels must be used in the safety function implementation. The safety data given in this manual is calculated for redundant use, and does not apply if both channels are not used.

The Safe torque off function complies with these standards:

| Standard                            | Name   |
|-------------------------------------|--|
| IEC 60204-1:2021<br>EN 60204-1:2018 | Safety of machinery – Electrical equipment of machines – Part 1: General requirements  |
| IEC 61000-6-7:2014                  | Electromagnetic compatibility (EMC) – Part 6-7: Generic standards – Immunity requirements for equipment intended to perform functions in a safety-related system (functional safety) in industrial locations |

---

## 270 The Safe torque off function

| Standard                                | Name  |
|---|---|
| IEC 61326-3-1:2017                      | Electrical equipment for measurement, control and laboratory use – EMC requirements – Part 3-1: Immunity requirements for safety-related systems and for equipment intended to perform safety-related functions (functional safety) – General industrial applications |
| IEC 61508-1:2010                        | Functional safety of electrical/electronic/programmable electronic safety-related systems – Part 1: General requirements  |
| IEC 61508-2:2010                        | Functional safety of electrical/electronic/programmable electronic safety-related systems – Part 2: Requirements for electrical/electronic/programmable electronic safety-related systems   |
| IEC 61511-1:2017                        | Functional safety – Safety instrumented systems for the process industry sector   |
| IEC 61800-5-2:2016<br>EN 61800-5-2:2007 | Adjustable speed electrical power drive systems – Part 5-2: Safety requirements – Functional  |
| EN IEC 62061:2021                       | Safety of machinery – Functional safety of safety-related control systems   |
| EN ISO 13849-1:2015                     | Safety of machinery – Safety-related parts of control systems – Part 1: General principles for design   |
| EN ISO 13849-2:2012                     | Safety of machinery – Safety-related parts of control systems – Part 2: Validation  |

The function also corresponds to Prevention of unexpected start-up as specified by EN ISO 14118:2018 (ISO 14118:2017), and Uncontrolled stop (stop category 0) as specified in EN/IEC 60204-1.

### ■ Compliance with the European Machinery Directive and the UK Supply of Machinery (Safety) Regulations

See the technical data.

## Wiring

For the electrical specifications of the STO connection, see the technical data of the control unit.

### ■ Connection principle

#### Single ACH580-07 drive, internal power supply

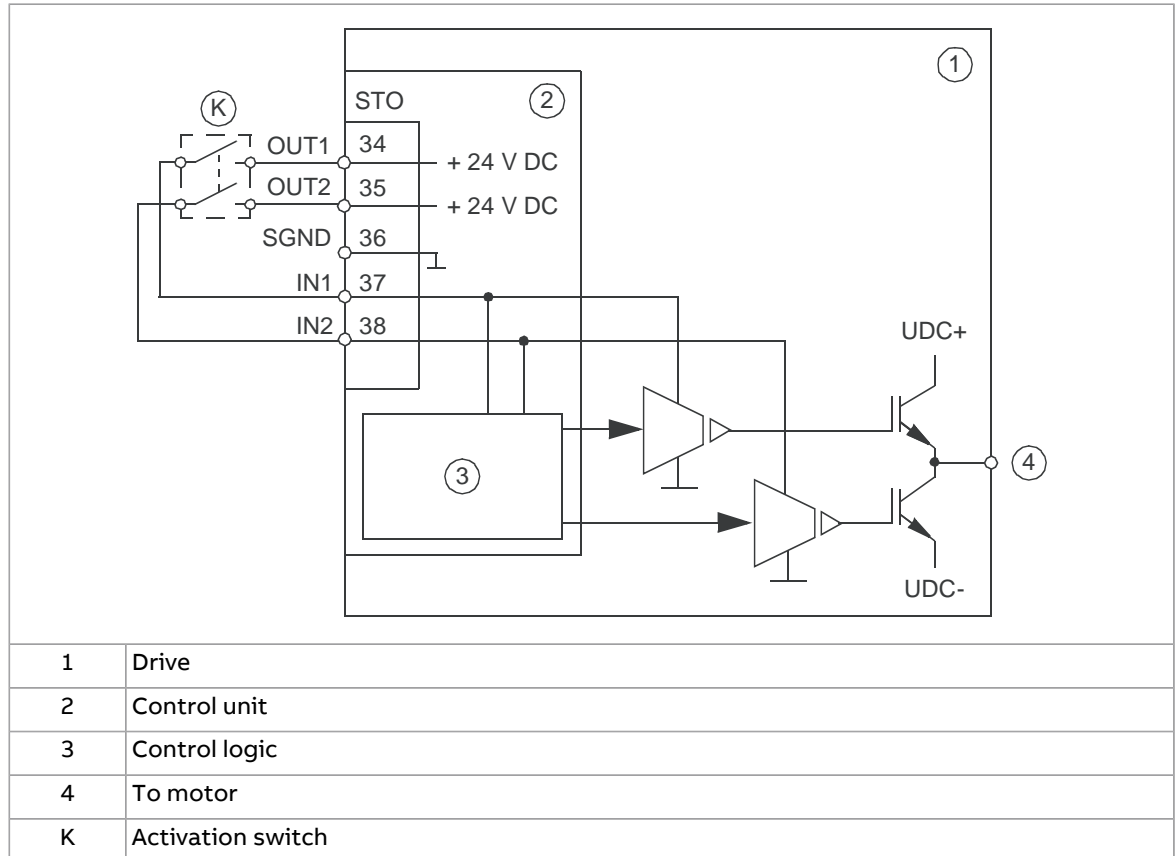

#### Single ACH580-07 drive, external power supply

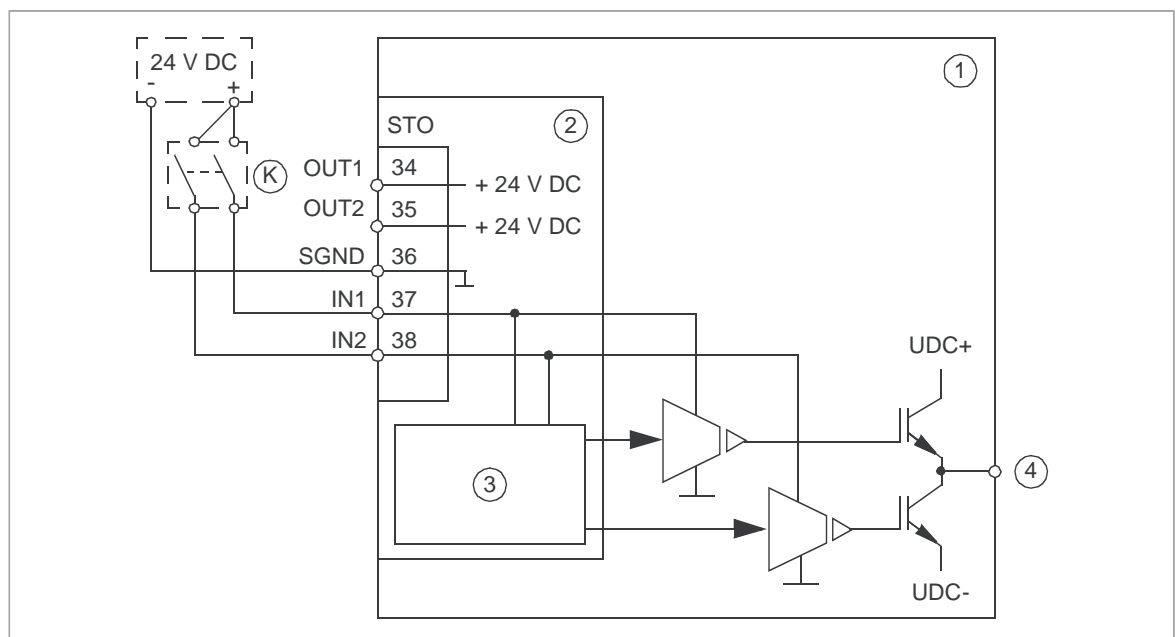

## 272 The Safe torque off function

|   |                   |
|---|-------------------|
| 1 | Drive             |
| 2 | Control unit      |
| 3 | Control logic     |
| 4 | To motor          |
| K | Activation switch |

### ■ Wiring examples

#### Single ACH580-07 drive, internal power supply

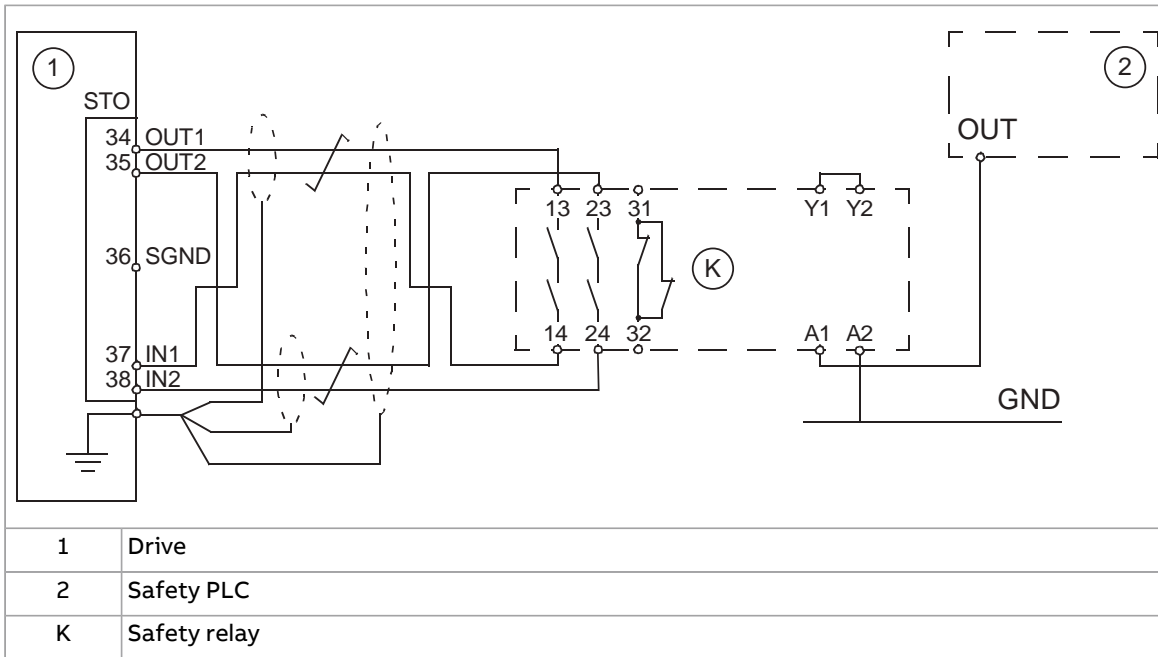

#### Single ACH580-07 drive, external power supply

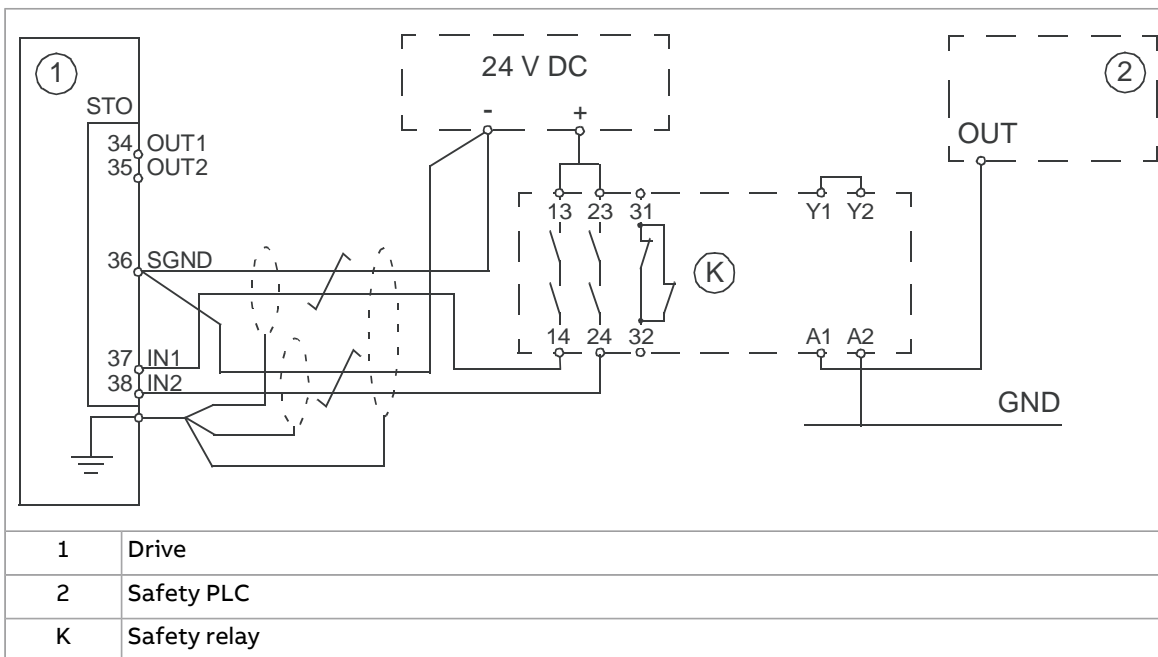



**Multiple ACH580-07 drives, internal power supply**

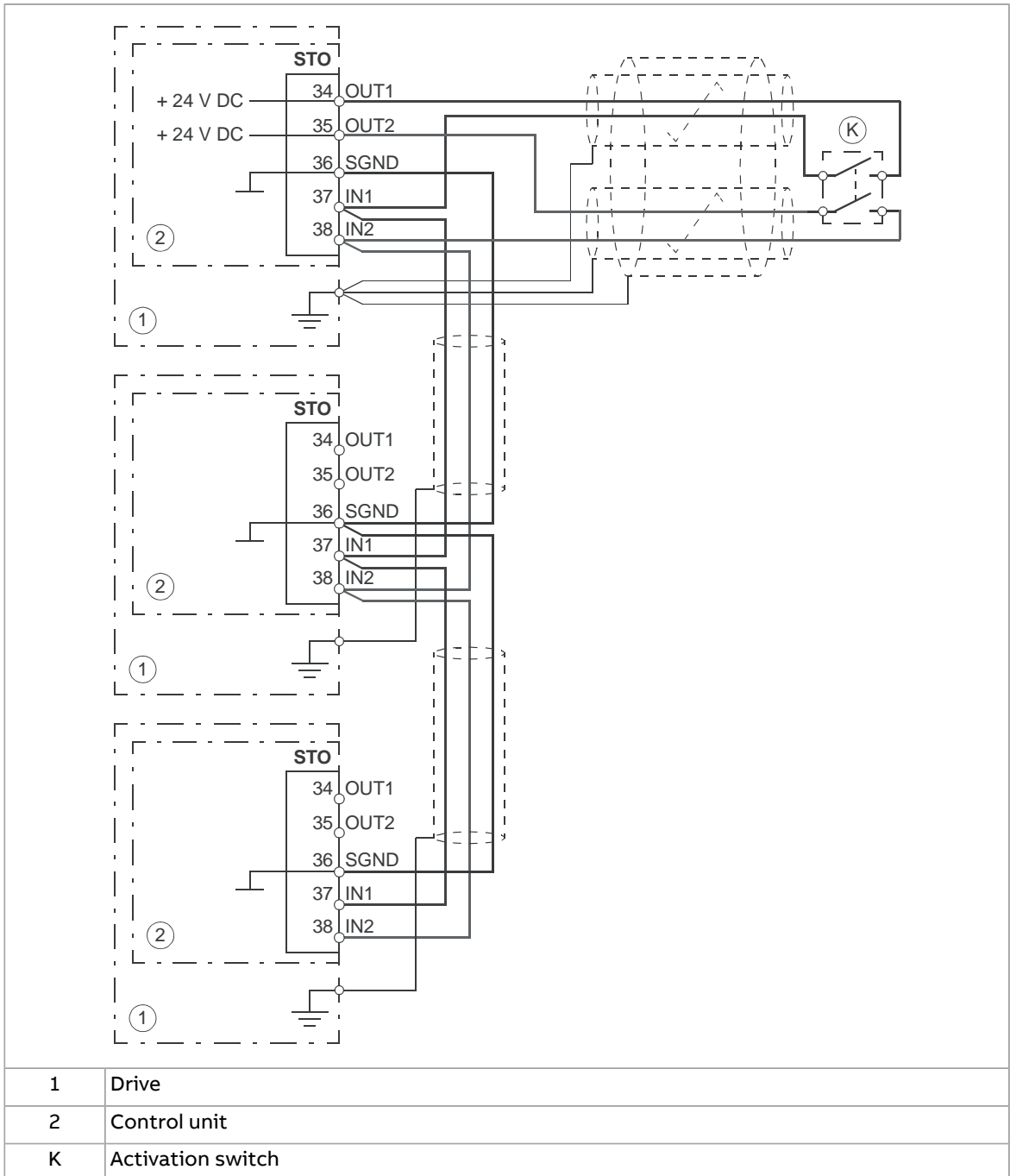

**Multiple ACH580-07 drives, external power supply**

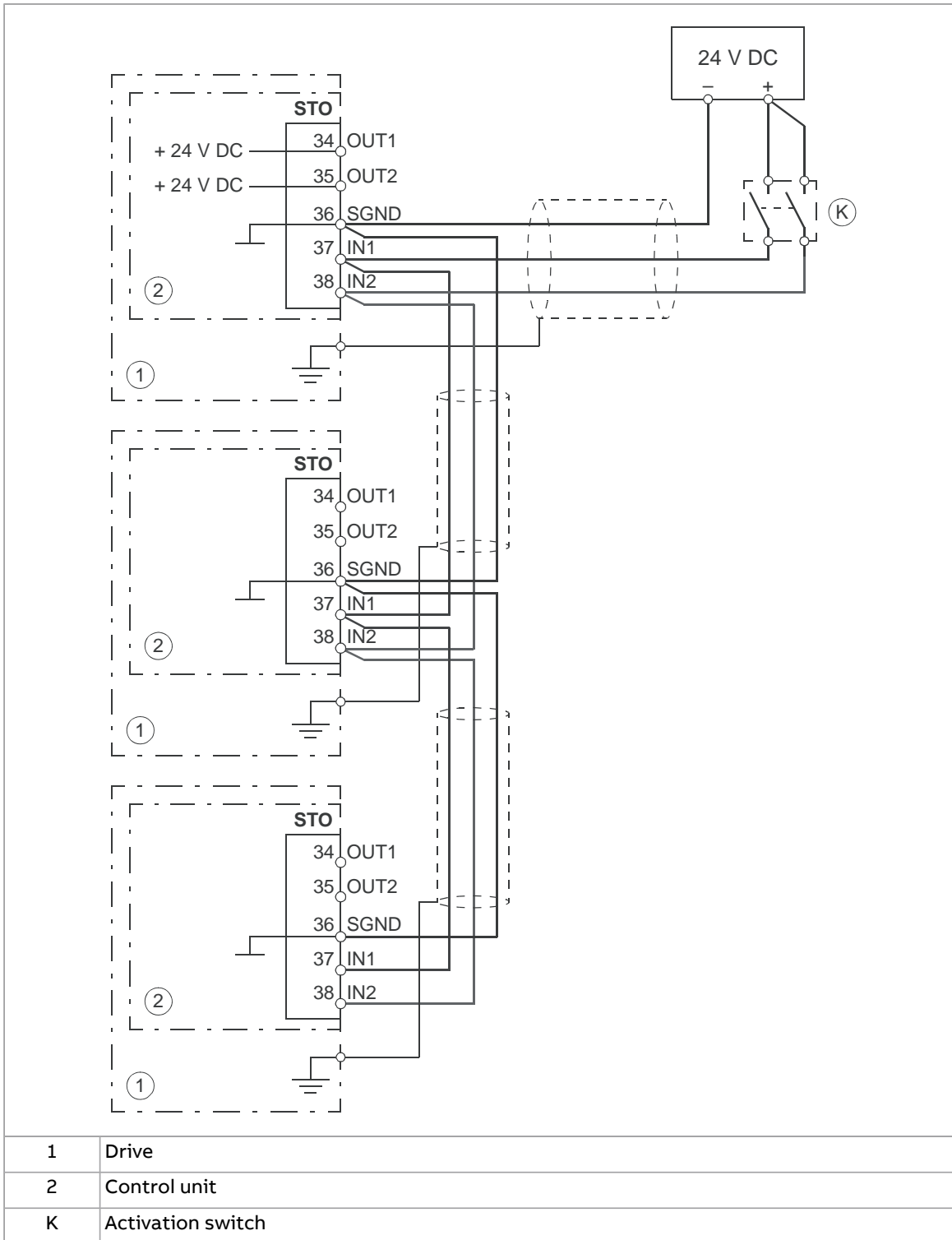

■ **Activation switch**

In the wiring diagrams, the activation switch has the designation [K]. This represents a component such as a manually operated switch, an emergency stop push button switch, or the contacts of a safety relay or safety PLC.

- In case a manually operated activation switch is used, the switch must be of a type that can be locked out to the open position.
- The contacts of the switch or relay must open/close within 200 ms of each other.
- A CPTC thermistor protection module or an FSPS safety functions module can also be used. For more information, see the module documentation.

#### ■ Cable types and lengths

- ABB recommends double-shielded twisted-pair cable.
- Maximum cable lengths:
  - 300 m (1000 ft) between activation switch [K] and drive control unit
  - 60 m (200 ft) between multiple drives
  - 60 m (200 ft) between external power supply and first control unit

**Note:** A short-circuit in the wiring between the switch and an STO terminal causes a dangerous fault. Therefore, it is recommended to use a safety relay (including wiring diagnostics) or a wiring method (shield grounding, channel separation) which reduces or eliminates the risk caused by the short-circuit.

**Note:** The voltage at the STO input terminals of the drive must be at least 13 V DC to be interpreted as “1”.

The pulse tolerance of the input channels is 1 ms.

#### ■ Grounding of protective shields

- Ground the shield in the cabling between the activation switch and the control unit at the control unit only.
  - Ground the shield in the cabling between two control units at one control unit only.
-

## Operation principle

1. The Safe torque off activates (the activation switch is opened, or safety relay contacts open).
2. The STO inputs of the drive control unit de-energize.
3. The control unit cuts off the control voltage from the output IGBTs.
4. The control program generates an indication as defined by parameter 31.22 (see the firmware manual of the drive).

The parameter selects which indications are given when one or both STO signals are switched off or lost. The indications also depend on whether the drive is running or stopped when this occurs.

**Note:** This parameter does not affect the operation of the STO function itself. The STO function will operate regardless of the setting of this parameter: a running drive will stop upon removal of one or both STO signals, and will not start until both STO signals are restored and all faults reset.

**Note:** The loss of only one STO signal always generates a fault as it is interpreted as a malfunction of STO hardware or wiring.

5. The motor coasts to a stop (if running). The drive cannot restart while the activation switch or safety relay contacts are open. After the contacts close, a reset may be needed (depending on the setting of parameter 31.22). A new start command is required to start the drive.
-

## Start-up including validation test

To ensure the safe operation of a safety function, validation is required. The final assembler of the machine must validate the function by performing a validation test. The test must be performed

1. at initial start-up of the safety function
2. after any changes related to the safety function (circuit boards, wiring, components, settings, replacement of inverter module, etc.)
3. after any maintenance work related to the safety function
4. after a drive firmware update
5. at the proof test of the safety function.

### ■ Competence

The validation test of the safety function must be carried out by a competent person with adequate expertise and knowledge of the safety function as well as functional safety, as required by IEC 61508-1 clause 6. The test procedures and report must be documented and signed by this person.

### ■ Validation test reports

Signed validation test reports must be stored in the logbook of the machine. The report shall include documentation of start-up activities and test results, references to failure reports and resolution of failures. Any new validation tests performed due to changes or maintenance shall be logged into the logbook.

### ■ Validation test procedure

After wiring the Safe torque off function, validate its operation as follows.

**Note:** If the drive is equipped with safety option +Q951 or +Q963, do the procedure shown in the documentation of the option.

**Note:** If a CPTC-02 module is installed, refer to its documentation.

|   |                                     |
|---|-------------------------------------|
| <b>Action</b>   | <input checked="" type="checkbox"/> |
|  <b>WARNING!</b><br>Obey the safety instructions. If you ignore them, injury or death, or damage to the equipment can occur. | <input type="checkbox"/>            |
| Make sure that the motor can be run and stopped freely during start-up.   | <input type="checkbox"/>            |
| Stop the drive (if running), switch the input power off and isolate the drive from the power line using a disconnecter.   | <input type="checkbox"/>            |
| Check the STO circuit connections against the wiring diagram.   | <input type="checkbox"/>            |
| Close the disconnecter and switch the power on.   | <input type="checkbox"/>            |

278 The Safe torque off function

|  |                                     |
|--|-------------------------------------|
| <b>Action</b>  | <input checked="" type="checkbox"/> |
| <p>Test the operation of the STO function when the motor is stopped.</p> <ul style="list-style-type: none"> <li>• Give a stop command for the drive (if running) and wait until the motor shaft is at a standstill.</li> </ul> <p>Make sure that the drive operates as follows:</p> <ul style="list-style-type: none"> <li>• Open the STO circuit. The drive generates an indication if one is defined for the 'stopped' state in parameter 31.22 (see the firmware manual).</li> <li>• Give a start command to verify that the STO function blocks the drive's operation. The motor should not start.</li> <li>• Close the STO circuit.</li> <li>• Reset any active faults. Restart the drive and check that the motor runs normally.</li> </ul>  | <input type="checkbox"/>            |
| <p>Test the operation of the STO function when the motor is running.</p> <ul style="list-style-type: none"> <li>• Start the drive and make sure the motor is running.</li> <li>• Open the STO circuit. The motor should stop. The drive generates an indication if one is defined for the 'running' state in parameter 31.22 (see the firmware manual).</li> <li>• Reset any active faults and try to start the drive.</li> <li>• Make sure that the motor stays at a standstill and the drive operates as described above in testing the operation when the motor is stopped.</li> <li>• Close the STO circuit.</li> <li>• Reset any active faults. Restart the drive and check that the motor runs normally.</li> </ul>  | <input type="checkbox"/>            |
| <p>Test the operation of the failure detection of the drive. The motor can be stopped or running.</p> <ul style="list-style-type: none"> <li>• Open the 1st input channel of the STO circuit. If the motor was running, it should coast to a stop. The drive generates an FA81 fault indication (see the firmware manual).</li> <li>• Give a start command to verify that the STO function blocks the drive's operation. The motor should not start.</li> <li>• Open the STO circuit (both channels).</li> <li>• Give a reset command.</li> <li>• Close the STO circuit (both channels).</li> <li>• Reset any active faults. Restart the drive and check that the motor runs normally.</li> <li>• Open the 2nd input channel of the STO circuit. If the motor was running, it should coast to a stop. The drive generates an FA82 fault indication (see the firmware manual).</li> <li>• Give a start command to verify that the STO function blocks the drive's operation. The motor should not start.</li> <li>• Open the STO circuit (both channels).</li> <li>• Give a reset command.</li> <li>• Close the STO circuit (both channels).</li> <li>• Reset any active faults. Restart the drive and check that the motor runs normally.</li> </ul> | <input type="checkbox"/>            |
| <p>Document and sign the validation test report which verifies that the safety function is safe and accepted for operation.</p>  | <input type="checkbox"/>            |

## Use

1. Open the activation switch, or activate the safety functionality that is wired to the STO connection.
2. The STO inputs on the drive control unit de-energize, and the control unit cuts off the control voltage from the output IGBTs.
3. The control program generates an indication as defined by parameter 31.22 (see the firmware manual of the drive).
4. The motor coasts to a stop (if running). The drive will not restart while the activation switch or safety relay contacts are open.
5. Deactivate the STO by closing the activation switch, or resetting the safety functionality that is wired to the STO connection.
6. Reset any faults before restarting.



### WARNING!

The Safe torque off function does not disconnect the voltage of the main and auxiliary circuits from the drive. Therefore maintenance work on electrical parts of the drive or the motor can only be carried out after isolating the drive from the supply and all other voltage sources.

---



### WARNING!

The drive cannot detect or memorize any changes in the STO circuitry when the drive control unit is not powered or when the main power to the drive is off. If both STO circuits are closed and a level-type start signal is active when the power is restored, it is possible that the drive starts without a fresh start command. Take this into account in the risk assessment of the system.

This is also valid when the drive is only powered by a CMOD-xx multifunction extension module.

---



### WARNING!

Permanent magnet or synchronous reluctance [SynRM] motors only:

In case of a multiple IGBT power semiconductor failure, the drive can produce an alignment torque which maximally rotates the motor shaft by  $180/p$  degrees (with permanent magnet motors) or  $180/2p$  degrees (with synchronous reluctance [SynRM] motors) regardless of the activation of the Safe torque off function.  $p$  denotes the number of pole pairs.

---

### Notes:

- If a running drive is stopped by using the Safe torque off function, the drive will cut off the motor supply voltage and the motor will coast to a stop. If this causes danger or is not otherwise acceptable, stop the drive and machinery using the appropriate stop mode before activating the Safe torque off function.
  - The Safe torque off function overrides all other functions of the drive.
  - The Safe torque off function is ineffective against deliberate sabotage or misuse.
  - The Safe torque off function has been designed to reduce the recognized hazardous conditions. In spite of this, it is not always possible to eliminate all
-

## 280 The Safe torque off function

potential hazards. The assembler of the machine must inform the final user about the residual risks.



## Maintenance

After the operation of the circuit is validated at start-up, the STO function shall be maintained by periodic proof testing. In high demand mode of operation, the maximum proof test interval is 20 years. In low demand mode of operation, the maximum proof test interval is 10 years; see section [Safety data \(page 283\)](#). It is assumed that all dangerous failures of the STO circuit are detected by the proof test. To perform the proof test, do the [Validation test procedure \(page 277\)](#).

**Note:** See also the Recommendation of Use CNB/M/11.050 (published by the European co-ordination of Notified Bodies) concerning dual-channel safety-related systems with electromechanical outputs:

- When the safety integrity requirement for the safety function is SIL 3 or PL e (cat. 3 or 4), the proof test for the function must be performed at least every month.
- When the safety integrity requirement for the safety function is SIL 2 (HFT = 1) or PL d (cat. 3), the proof test for the function must be performed at least every 12 months.

The STO function of the drive does not contain any electromechanical components.

In addition to proof testing, it is a good practice to check the operation of the function when other maintenance procedures are carried out on the machinery.

Include the Safe torque off operation test described above in the routine maintenance program of the machinery that the drive runs.

If any wiring or component change is needed after start-up, or the parameters are restored, do the test given in section [Validation test procedure \(page 277\)](#).

Use only spare parts approved by ABB.

Record all maintenance and proof test activities in the machine logbook.

### ■ Competence

The maintenance and proof test activities of the safety function must be carried out by a competent person with adequate expertise and knowledge of the safety function as well as functional safety, as required by IEC 61508-1 clause 6.

---

## **Fault tracing**

The indications given during the normal operation of the Safe torque off function are selected by drive control program parameter 31.22.

The diagnostics of the Safe torque off function cross-compare the status of the two STO channels. In case the channels are not in the same state, a fault reaction function is performed and the drive trips on an FA81 or FA82 fault. An attempt to use the STO in a non-redundant manner, for example activating only one channel, will trigger the same reaction.

See the firmware manual of the drive control program for the indications generated by the drive, and for details on directing fault and warning indications to an output on the control unit for external diagnostics.

Any failures of the Safe torque off function must be reported to ABB.

---

## Safety data

The safety data for the Safe torque off function is given below.

**Note:** The safety data is calculated for redundant use, and applies only if both STO channels are used.

| Frame size | SIL | SC | PL | PFH<br>( $T_1 = 20$ a)<br>(1/h) | PFH <sub>avg</sub><br>( $T_1 = 2$ a) | PFH <sub>avg</sub><br>( $T_1 = 5$ a) | PFH <sub>avg</sub><br>( $T_1 = 10$ a) | MTTF <sub>D</sub><br>(a) | DC<br>(%) | SFF<br>(%) | Cat. | HFT | CCF | $T_M$<br>(a) | PFH <sub>diag</sub><br>(1/h) | $\lambda_{Diag,s}$<br>(1/h) | $\lambda_{Diag,d}$<br>(1/h) |
|------------|-----|----|----|---------------------------------|--------------------------------------|--------------------------------------|---------------------------------------|--------------------------|-----------|------------|------|-----|-----|--------------|------------------------------|-----------------------------|-----------------------------|
| R6<br>R7   | 3   | 3  | e  | 3.92E-09                        | 3.44E-05                             | 8.59E-05                             | 1.72E-04                              | 4802                     | ≥90       | >99        | 3    | 1   | 80  | 20           | 1.40E-12                     | 6.43E-08                    | 1.40E-10                    |
| R8<br>R9   | 3   | 3  | e  | 4.22E-09                        | 3.69E-05                             | 9.24E-05                             | 1.85E-04                              | 2805                     | ≥90       | >99        | 3    | 1   | 80  | 20           | 3.00E-12                     | 1.96E-07                    | 3.00E-10                    |
| R10<br>R11 | 3   | 3  | e  | 4.18E-09                        | 3.66E-05                             | 9.14E-05                             | 1.83E-04                              | 15080                    | ≥90       | 99.55      | 3    | 1   | 80  | 20           | 6.44E-11                     | 7.52E-07                    | 6.44E-09                    |

3AXD10001613533 C, 3AXD10001613536 B

- The STO is a type B safety component as defined in IEC 61508-2.
- Relevant failure modes:
  - The STO trips spuriously (safe failure)
  - The STO does not activate when requested
  - A fault exclusion on the failure mode “short circuit on printed circuit board” has been made (EN 13849-2, table D.5). The analysis is based on an assumption that one failure occurs at one time. No accumulated failures have been analyzed.
- STO response times:
  - STO reaction time (shortest detectable break): 1 ms
  - STO response time: 2 ms (typical), 5 ms (maximum)
  - Fault detection time: Channels in different states for longer than 200 ms
  - Fault reaction time: Fault detection time + 10 ms.
- Indication delays:
  - STO fault indication (parameter 31.22) delay: < 500 ms
  - STO warning indication (parameter 31.22) delay: < 1000 ms.

## ■ Terms and abbreviations

| Term or abbreviation | Reference            | Description  |
|----------------------|----------------------|--|
| Cat.                 | EN ISO 13849-1       | Classification of the safety-related parts of a control system in respect of their resistance to faults and their subsequent behavior in the fault condition, and which is achieved by the structural arrangement of the parts, fault detection and/or by their reliability. The categories are: B, 1, 2, 3 and 4. |
| CCF                  | EN ISO 13849-1       | Common cause failure (%)   |
| DC                   | EN ISO 13849-1       | Diagnostic coverage (%)  |
| HFT                  | IEC 61508            | Hardware fault tolerance   |
| MTTF <sub>D</sub>    | EN ISO 13849-1       | Mean time to dangerous failure: (Total number of life units) / (Number of dangerous, undetected failures) during a particular measurement interval under stated conditions   |
| PFD <sub>avg</sub>   | IEC 61508            | Average probability of dangerous failure on demand, that is, mean unavailability of a safety-related system to perform the specified safety function when a demand occurs  |
| PFH                  | IEC 61508            | Average frequency of dangerous failures per hour, that is, average frequency of a dangerous failure of a safety related system to perform the specified safety function over a given period of time  |
| PFH <sub>diag</sub>  | IEC/EN 62061         | Average frequency of dangerous failures per hour for the diagnostic function of STO  |
| PL                   | EN ISO 13849-1       | Performance level. Levels a...e correspond to SIL  |
| Proof test           | IEC 61508, IEC 62061 | Periodic test performed to detect failures in a safety-related system so that, if necessary, a repair can restore the system to an "as new" condition or as close as practical to this condition   |
| SC                   | IEC 61508            | Systematic capability (1...3)  |
| SFF                  | IEC 61508            | Safe failure fraction (%)  |
| SIL                  | IEC 61508            | Safety integrity level (1...3)   |
| STO                  | IEC/EN 61800-5-2     | Safe torque off  |

| Term or abbreviation      | Reference      | Description  |
|---------------------------|----------------|--|
| $T_1$                     | IEC 61508-6    | Proof test interval. $T_1$ is a parameter used to define the probabilistic failure rate (PFH or PFD) for the safety function or subsystem. Performing a proof test at a maximum interval of $T_1$ is required to keep the SIL capability valid. The same interval must be followed to keep the PL capability (EN ISO 13849) valid. See also section Maintenance. |
| $T_M$                     | EN ISO 13849-1 | Mission time: the period of time covering the intended use of the safety function/device. After the mission time elapses, the safety device must be replaced. Note that any $T_M$ values given cannot be regarded as a guarantee or warranty.  |
| $\lambda_{\text{Diag}_d}$ | IEC 61508-6    | Dangerous failure rate (per hour) of the diagnostics function of STO   |
| $\lambda_{\text{Diag}_s}$ | IEC 61508-6    | Safe failure rate (per hour) of the diagnostics function of STO  |

### ■ TÜV certificate

The TÜV certificate is available on the Internet.

# 15

## Disconnecting EMC filter and ground-to-phase varistor

**When to disconnect the ground-to-phase varistor: TN-S, IT, corner-grounded delta, midpoint-grounded delta and TT systems**

**Symmetrically grounded TN systems (TN-S systems, ie, center-grounded wye)**

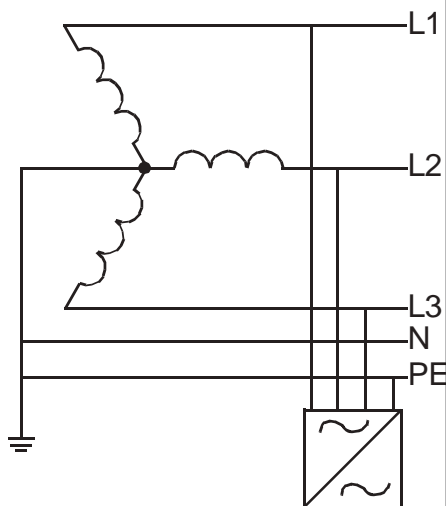

R6...R9: Do not remove EMC or VAR screws.

R10...R11: Do not disconnect VAR wire.

**Corner-grounded delta systems**

288 Disconnecting EMC filter and ground-to-phase varistor

|  |  |
|--|--|
|  | <p><u>R6...R9</u>: Do not remove EMC AC or VAR screws. Remove EMC DC screw.<br/> <u>R10...R11</u>: Do not disconnect VAR wire.</p> |
| <p><b>Midpoint-grounded delta systems</b></p>  |  |
|  | <p><u>R6...R9</u>: Do not remove EMC AC or VAR screws. Remove EMC DC screw.<br/> <u>R10...R11</u>: Do not disconnect VAR wire.</p> |
| <p><b>IT systems (ungrounded or high-resistance grounded [<math>&gt;30</math> ohms])</b></p> |  |
|  | <p><u>R6...R9</u>: Remove EMC screws (2 pcs) and VAR screw.<br/> <u>R10...R11</u>: Disconnect VAR wire.</p>                        |
| <p><b>TT systems</b></p>   |  |



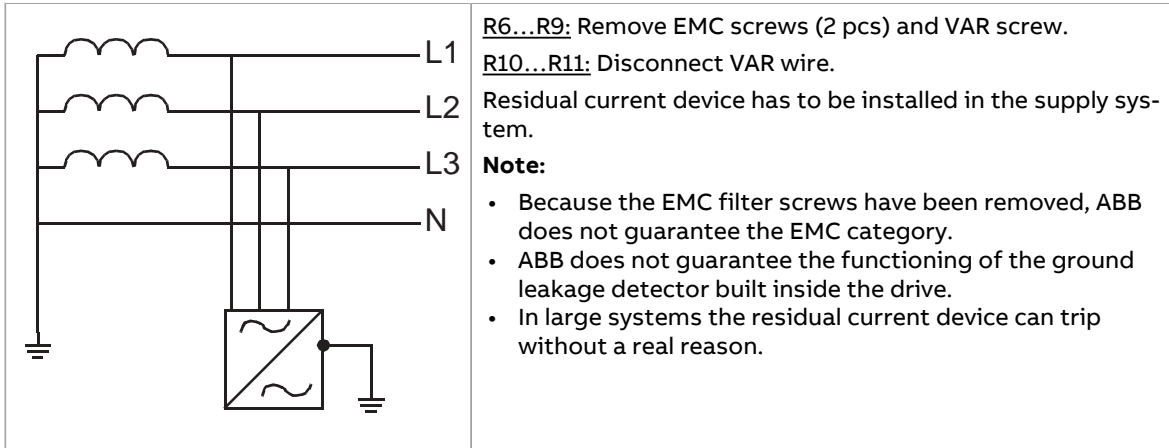

These are the EMC filter and varistor screws in different drive frame sizes.

| Frame size | EMC filter (+E200) screws | Ground-to-phase varistor screws |
|------------|---------------------------|---------------------------------|
| R6..R9     | Two EMC screws            | VAR                             |
| R10, R11   | -                         | VAR                             |

## Identifying the grounding system of the electrical power network



### WARNING!

Only a qualified electrical professional may do the work instructed in this section. Depending on the installation site, the work may even be categorized as live working. Continue only if you are an electrical professional certified for the work. Obey the local regulations. If you ignore them, injury or death can occur.

To identify the grounding system, examine the supply transformer connection. See the applicable electrical diagrams of the building. If that is not possible, measure these voltages at the distribution board, and use the table to define the grounding system type.

1. input voltage line to line ( $U_{L-L}$ )
2. input voltage line 1 to ground ( $U_{L1-G}$ )
3. input voltage line 2 to ground ( $U_{L2-G}$ )
4. input voltage line 3 to ground ( $U_{L3-G}$ ).

The table below shows the line-to-ground voltages in relation to the line-to-line voltage for each grounding system.

| $U_{L-L}$ | $U_{L1-G}$                | $U_{L2-G}$                | $U_{L3-G}$                | Electrical power system type   |
|-----------|---------------------------|---------------------------|---------------------------|--|
| X         | 0.58·X                    | 0.58·X                    | 0.58·X                    | TN-S system (symmetrically grounded)   |
| X         | 1.0·X                     | 1.0·X                     | 0                         | Corner-grounded delta system (nonsymmetrical)  |
| X         | 0.866·X                   | 0.5·X                     | 0.5·X                     | Midpoint-grounded delta system (nonsymmetrical)  |
| X         | Varying level versus time | Varying level versus time | Varying level versus time | IT systems (ungrounded or high-resistance-grounded [ $>30$ ohms]) nonsymmetrical   |
| X         | Varying level versus time | Varying level versus time | Varying level versus time | TT system (the protective earth connection for the consumer is provided by a local earth electrode, and there is another independently installed at the generator) |

## Disconnecting the EMC filter and ground-to-phase varistor (IEC frames R6...R9)

To disconnect the internal EMC filter or ground-to-phase varistor, do as follows:

1. Switch off the power from the drive.
2. Open the cover, if not already opened.
3. To disconnect the internal EMC filter, remove the two EMC screws.
4. To disconnect the ground-to-phase varistor, remove the varistor screw.

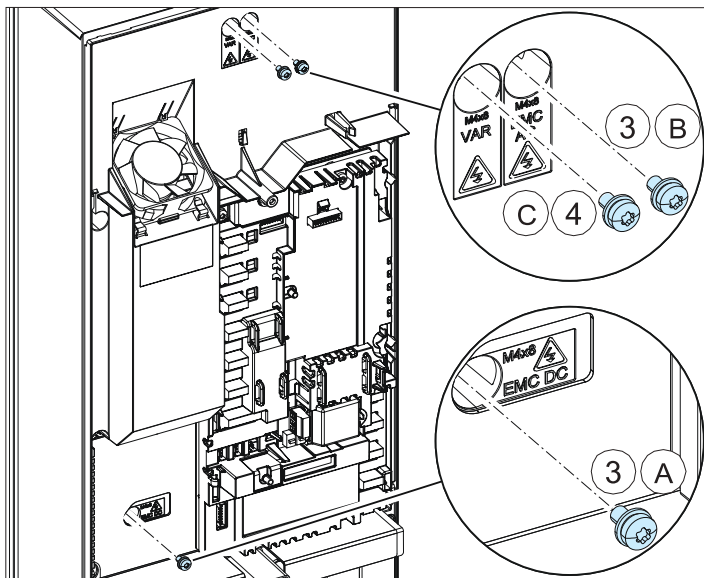

|   |          |
|---|----------|
| A | EMC (DC) |
| B | EMC (AC) |
| C | VAR      |

## Disconnecting internal EMC filter or ground-to-phase varistor (UL/NEC frames R6...R9)

Extra screws to configure the drive for different networks are provided in the drive shipment.

To disconnect the internal EMC filter or ground-to-phase varistor:

1. Do the steps in section [Electrical safety precautions \(page 18\)](#) before you start the work.
2. Open the cover, if not already opened.
3. To disconnect the internal EMC filters:
  - The DC EMC filter is disconnected by default with no screw or with a plastic screw (3A).
  - The AC EMC filter is disconnected by default with no screw or with a plastic screw (3B).
4. To disconnect the ground-to-phase varistor, remove the metal varistor screw (4) or replace it with the plastic screw provided in the package.

**R6...R9**

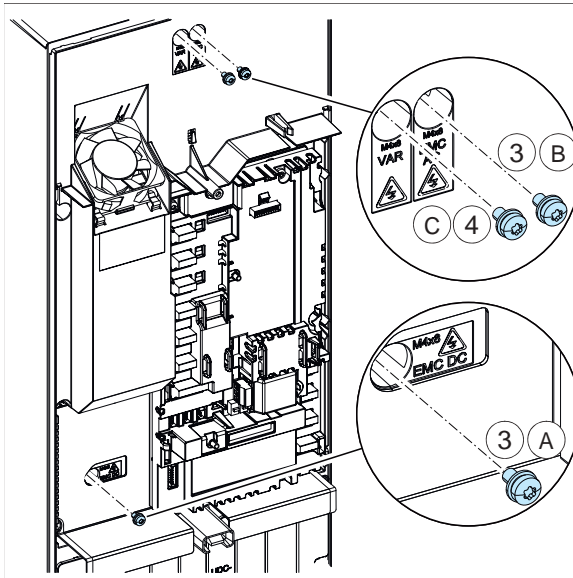

|   | Screw    |
|---|----------|
| A | EMC (DC) |
| B | EMC (AC) |
| C | VAR      |

## Disconnecting the ground-to-phase varistor (frames R10 and R11)

Varistor (VAR) grounding wire is attached next to the control circuit compartment. Insulate the end of the varistor grounding wire. Attach the wire to the module frame with a cable tie.





16

## CAIO-01 bipolar analog I/O adapter module

---

### Contents of this chapter

This chapter describes how to install and start up the optional CAIO-01 multifunction extension module. The chapter also contains diagnostics and technical data.

### Product overview

The CAIO-01 bipolar analog I/O module expands the inputs and outputs of the drive control unit. It has three bipolar current/voltage inputs and two unipolar current/voltage outputs. The inputs can handle positive and negative signals. The way the drive interprets the negative range of the inputs depends on the parameter settings of the drive. The voltage/current selection of the inputs is done with a parameter.

---

## Layout

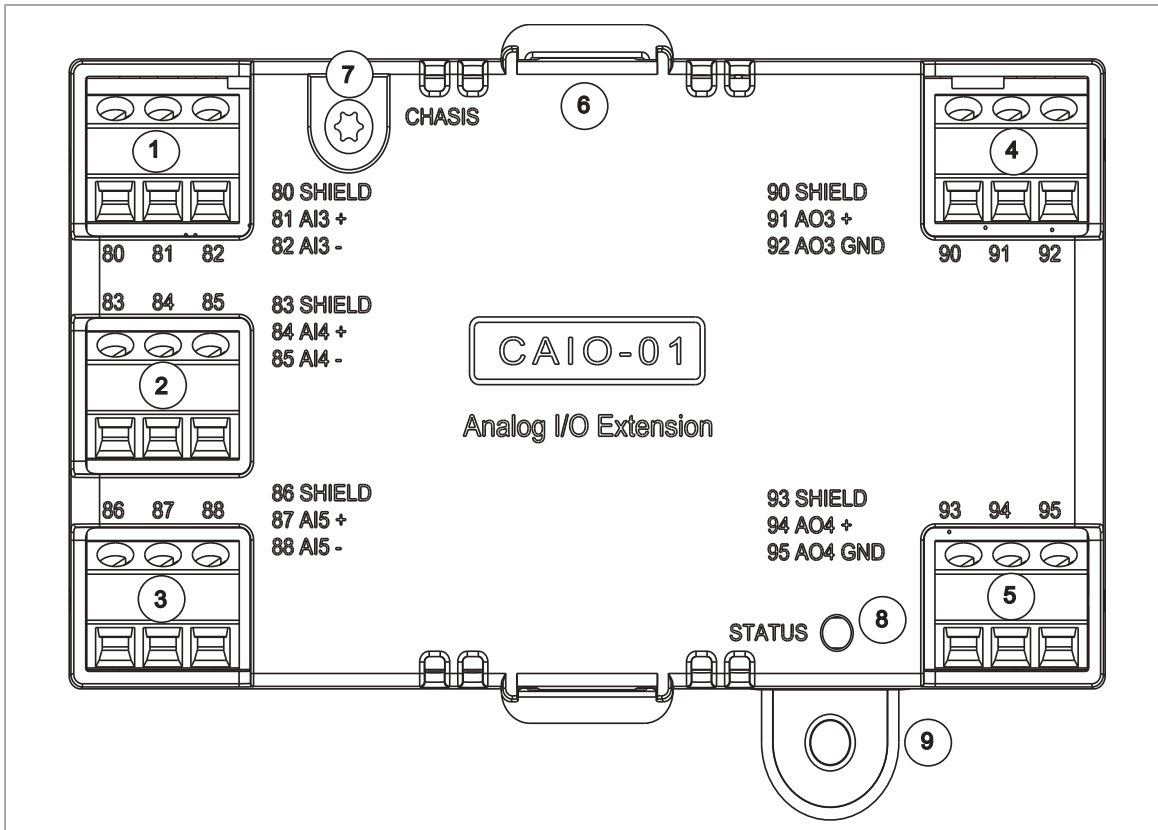

| 1, 2, 3 | Analog inputs               |                                | 4, 5 | Analog outputs |                         |
|---------|-----------------------------|--------------------------------|------|----------------|-------------------------|
| 80      | SHIELD                      | Cable shield connection        | 90   | SHIELD         | Cable shield connection |
| 81      | AI3+                        | Analog input 3 positive signal | 91   | AO3            | Analog output 3 signal  |
| 82      | AI3-                        | Analog input 3 negative signal | 92   | AGND           | Analog ground potential |
| 83      | SHIELD                      | Cable shield connection        | 93   | SHIELD         | Cable shield connection |
| 84      | AI4+                        | Analog input 4 positive signal | 94   | AO4            | Analog output 4 signal  |
| 85      | AI4-                        | Analog input 4 negative signal | 95   | AGND           | Analog ground potential |
| 86      | SHIELD                      | Cable shield connection        |      |                |                         |
| 87      | AI5+                        | Analog input 5 positive signal |      |                |                         |
| 88      | AI5-                        | Analog input 5 negative signal |      |                |                         |
| 6       | Control unit slot interface |                                |      |                |                         |
| 7       | Grounding hole              |                                |      |                |                         |
| 8       | Diagnostic LED              |                                |      |                |                         |
| 9       | Mounting hole               |                                |      |                |                         |

## Mechanical installation

### ■ Necessary tools

- Screwdriver and a set of suitable bits.

### ■ Unpacking and examining the delivery

1. Open the option package. Make sure that the package contains:
  - the option module
  - a mounting screw.
2. Make sure that there are no signs of damage.

### ■ Installing the module

See section [Installing option modules \(page 128\)](#).

## Electrical installation



### WARNING!

Obey the safety instructions of the drive. If you ignore them, injury or death, or damage to the equipment can occur.

Stop the drive and do the steps in section [Electrical safety precautions \(page 18\)](#) before you start the work.

### ■ Necessary tools

- Screwdriver and a set of suitable bits.

### ■ Wiring

Connect the external cables to the applicable module terminals. Ground the outer shield of the cables to the SHIELD terminal.

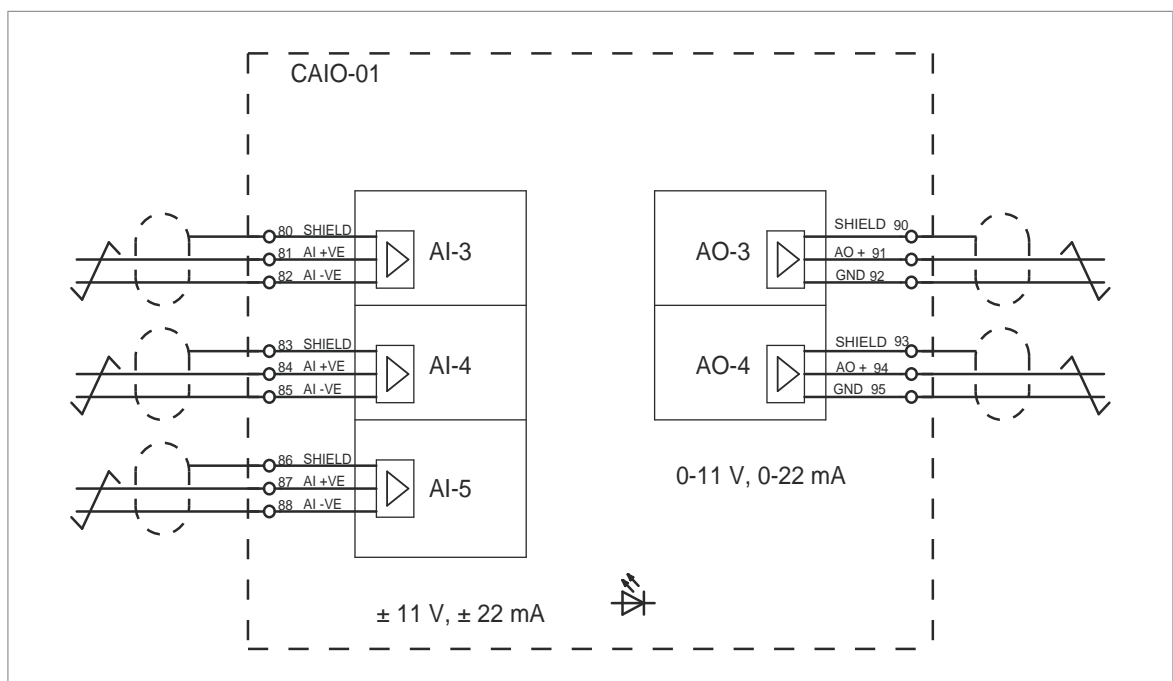

## Start-up

### ■ Setting the parameters

1. Power up the drive.
2. If no warning is shown,
  - make sure that the value of both parameters 15.01 Extension module type and 15.02 Detected extension module is CAIO-01.
 If warning A7AB Extension I/O configuration failure is shown,
  - make sure that the value of 15.02 is CAIO-01
  - set the value of parameter 15.01 to CAIO-01.
 You can now see the parameters of the extension module in group 15 I/O extension module.
3. Set the parameters of analog inputs AI3, AI4, AI5 or analog outputs AO3 or AO4 to applicable values, see the firmware manual.

Example: To connect supervision 1 to AI3 of the extension module:

- Select the mode of the supervision function (32.05 Supervision function 1).
- Set limits for the supervision function (32.09 Supervision 1 low and 32.10 Supervision 1 high).
- Select the supervision action (32.06 Supervision 1 action).
- Connect 32.07 Supervision 1 signal to 15.52 AI3 scaled value.

## Diagnostics

### ■ LEDs

The adapter module has one diagnostic LED.

| Color | Description  |
|-------|--|
| Green | The adapter module is powered up.  |
| Red   | There is no communication with the drive control unit or the adapter module has detected an error. |

## Technical data

|   |  |
|---|--|
| Installation                                  | Into slot 2 of drive control unit                |
| Degree of protection                          | IP20 / UL 1 Type                                 |
| Ambient conditions                            | See the drive technical data.                    |
| Package                                       | Cardboard  |
| <b>Analog inputs (80..82, 83..85, 86..88)</b> |  |
| Maximum wire size                             | 1.5 mm <sup>2</sup>                              |
| Input voltage ( AI+ and AI-)                  | -11 V ... +11 V                                  |
| Input current ( AI+ and AI-)                  | -22 mA ... +22 mA                                |
| Input resistance                              | >200 kohm (voltage mode), 100 ohm (current mode) |
| Optional cable shield connections             |  |
| <b>Analog outputs (90..92, 93..95)</b>        |  |



|                                   |  |
|-----------------------------------|--|
| Maximum wire size                 | 1.5 mm <sup>2</sup>                          |
| Output voltage (AO+ and AO-)      | 0 V ... +11 V                                |
| Output current (AO+ and AO-)      | 0 mA ... +22 mA                              |
| Output resistance                 | < 20 ohm                                     |
| Recommended load                  | >10 kohm                                     |
| Inaccuracy                        | ± 1% Typical, ± 1.5% Max of full-scale value |
| Optional cable shield connections |  |

■ **Isolation areas**

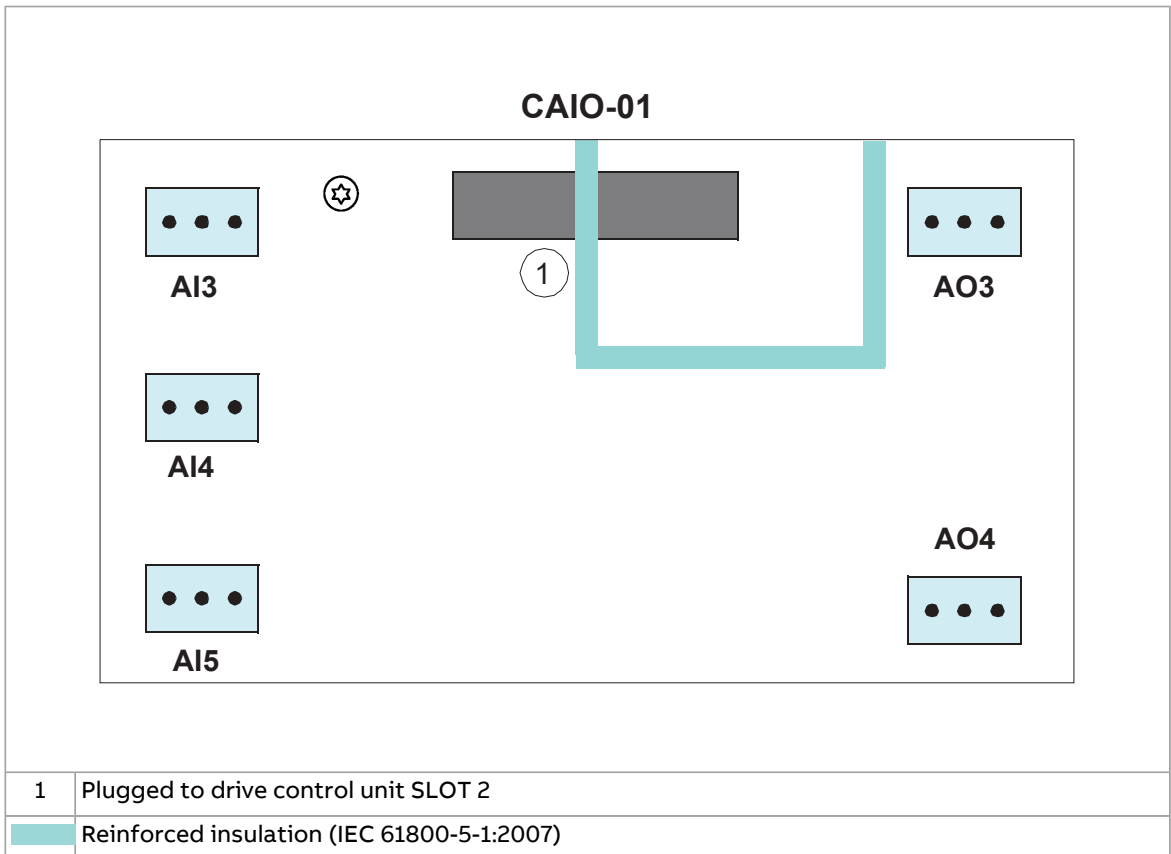

## Dimension drawings

The dimensions are in millimeters.

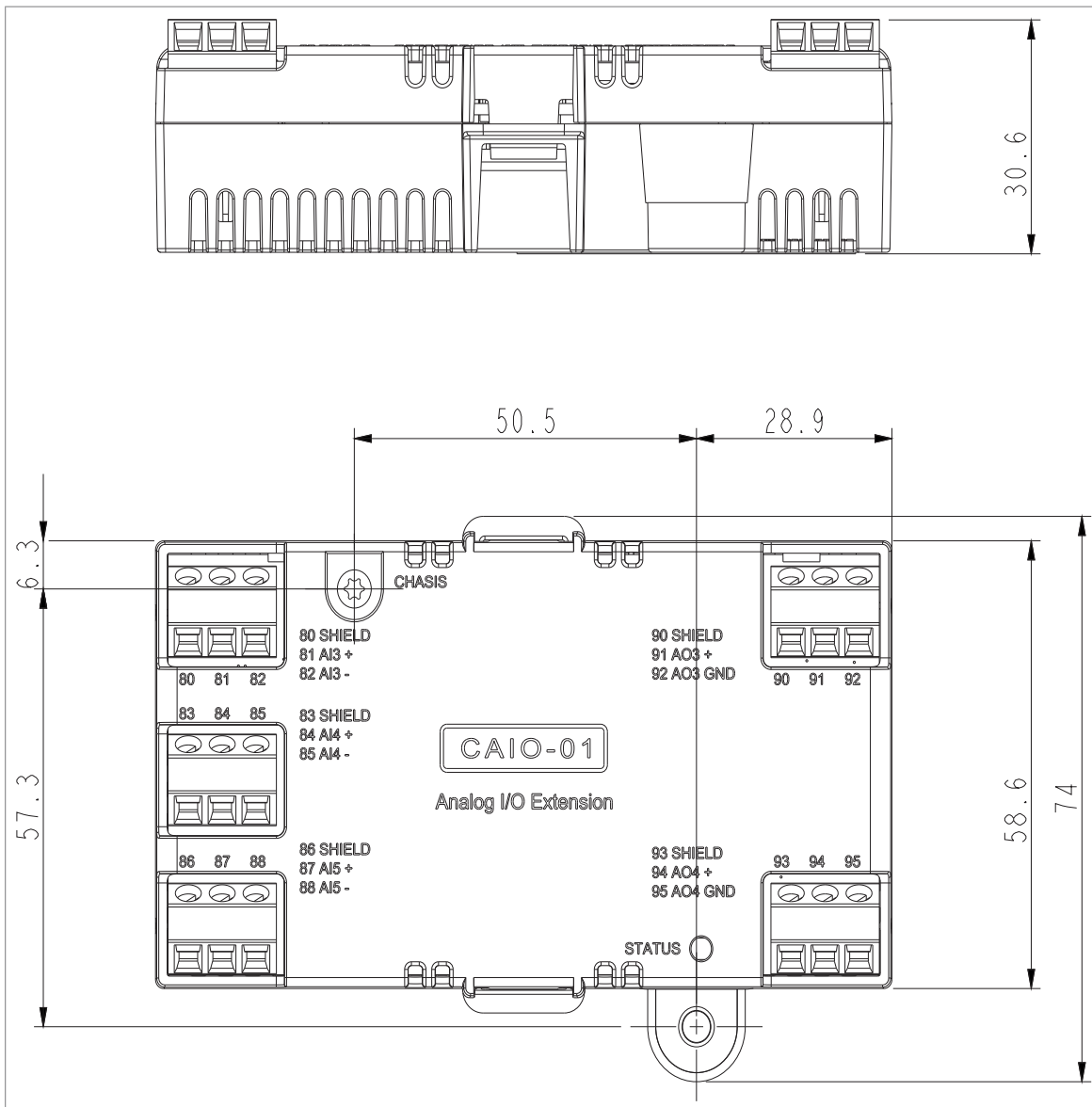

# 17

## **CHDI-01 115/230 V digital input extension module**

---

### **Contents of this chapter**

This chapter describes how to install and start up the optional CHDI-01 multifunction extension module. The chapter also contains diagnostics and technical data.

### **Product overview**

The CHDI-01 115/230 V digital input extension module expands the inputs of the drive control unit. It has six high voltage inputs and two relay outputs.

---

## Layout and connection examples

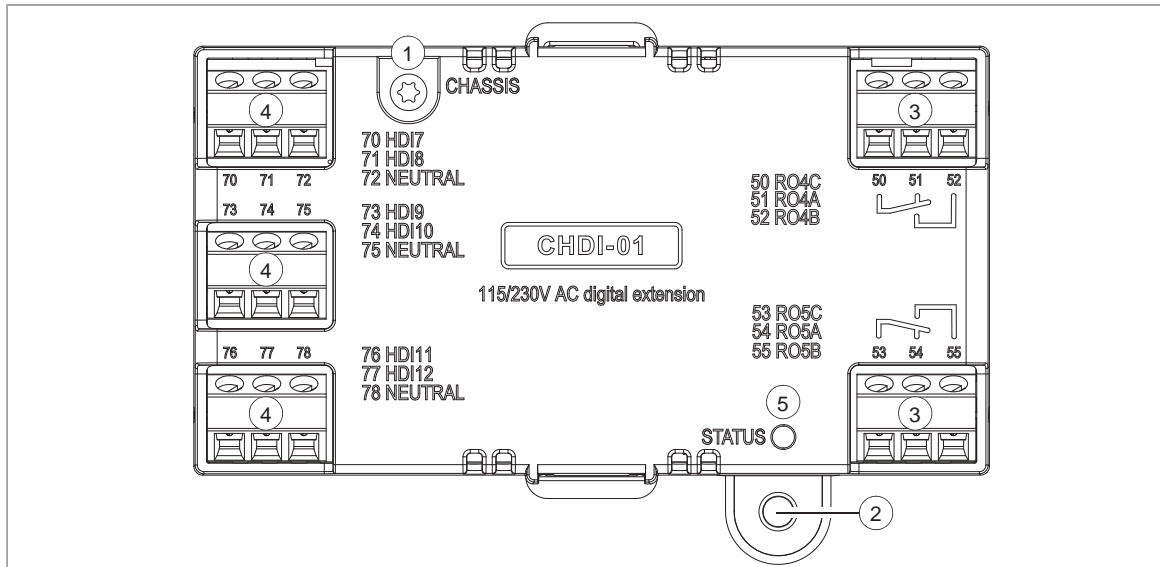

| 4 3-pin terminal blocks for 115/230 V inputs              |                       |                   | 3 Relay outputs |  |                     |
|---|-----------------------|-------------------|-----------------|--|---------------------|
|   |                       |                   |                 |  |                     |
| 70  | HDI7                  | 115/230 V input 1 | 50              | RO4C   | Common, C           |
| 71  | HDI8                  | 115/230 V input 2 | 51              | RO4A   | Normally closed, NC |
| 72  | NEUTRAL <sup>1)</sup> | Neutral point     | 52              | RO4B   | Normally open, NO   |
| 73  | HDI9                  | 115/230 V input 3 | 53              | RO5C   | Common, C           |
| 74  | HDI10                 | 115/230 V input 4 | 54              | RO5A   | Normally closed, NC |
| 75  | NEUTRAL <sup>1)</sup> | Neutral point     | 55              | RO5B   | Normally open, NO   |
| 76  | HDI11                 | 115/230 V input 5 | 1               | <b>Grounding screw</b>   |                     |
| 77  | HDI12                 | 115/230 V input 5 | 2               | <b>Hole for mounting screw</b>                                     |                     |
| 78  | NEUTRAL <sup>1)</sup> | Neutral point     | 5               | <b>Diagnostic LED.</b> Green = The extension module is powered up. |                     |
| <sup>1)</sup> Neutral points 72, 75 and 78 are connected. |                       |                   |                 |  |                     |

## Mechanical installation

### ■ Necessary tools

- Screwdriver and a set of suitable bits.

### ■ Unpacking and examining the delivery

1. Open the option package. Make sure that the package contains:
  - the option module
  - a mounting screw.
2. Make sure that there are no signs of damage.

### ■ Installing the module

See section [Installing option modules \(page 128\)](#).

## Electrical installation



### **WARNING!**

Obey the safety instructions of the drive. If you ignore them, injury or death, or damage to the equipment can occur.

Stop the drive and do the steps in section [Electrical safety precautions \(page 18\)](#) before you start the work.

### ■ Necessary tools

- Screwdriver and a set of suitable bits.

### ■ Wiring

Connect the external control cables to the applicable module terminals. Ground the outer shield of the control cables at the cabinet entry.

## Start-up

### ■ Setting the parameters

1. Power up the drive.
2. If no warning is shown,
  - make sure that the value of both parameters 15.01 Extension module type and 15.02 Detected extension module is CHDI-01.
 If warning the A7AB Extension I/O configuration failure is shown,
  - make sure that the value of parameter 15.02 is CHDI-01.
  - set parameter 15.01 value to CHDI-01.
 You can now see the parameters of the extension module in parameter group 15 I/O extension module.
3. Set the parameters of the extension module to applicable values.

### Parameter setting example for relay output

This example shows how make the relay output RO4 of the extension module indicate the reverse direction of rotation of the motor with a one-second delay.

## 302 CHDI-01 115/230 V digital input extension module

| Parameter           | Setting |
|---------------------|---------|
| 15.07 RO4 source    | Reverse |
| 15.08 RO4 ON delay  | 1 s     |
| 15.09 RO4 OFF delay | 1 s     |

## Fault and warning messages

Warning A7AB Extension I/O configuration failure.

## Technical data

|  |   |
|--|---|
| Installation                                 | Into an option slot on the drive control unit |
| Degree of protection                         | IP20 / UL Type 1                              |
| Ambient conditions                           | See the drive technical data.                 |
| Package                                      | Cardboard                                     |
| <b>Relay outputs (50...52, 53...55)</b>      |   |
| Maximum wire size                            | 1.5 mm <sup>2</sup>                           |
| Minimum contact rating                       | 12 V / 10 mA                                  |
| Maximum contact rating                       | 250 V AC / 30 V DC / 2 A                      |
| Maximum breaking capacity                    | 1500 VA                                       |
| <b>115/230 V inputs (70...78)</b>            |   |
| Maximum wire size                            | 1.5 mm <sup>2</sup>                           |
| Input voltage                                | 115 to 230 V AC ±10%                          |
| Maximum current leakage in digital off state | 2 mA  |
| <b>Isolation areas</b>                       |   |
|  |   |
| 1  | Plugged to drive <b>SLOT2</b>                 |
|  | Reinforced insulation (IEC 61800-5-1:2007)    |
|  | Functional insulation (IEC 61800-5-1:2007)    |

## Dimension drawing

The dimensions are in millimeters and [inches].

CHDI-01 115/230 V digital input extension module 303

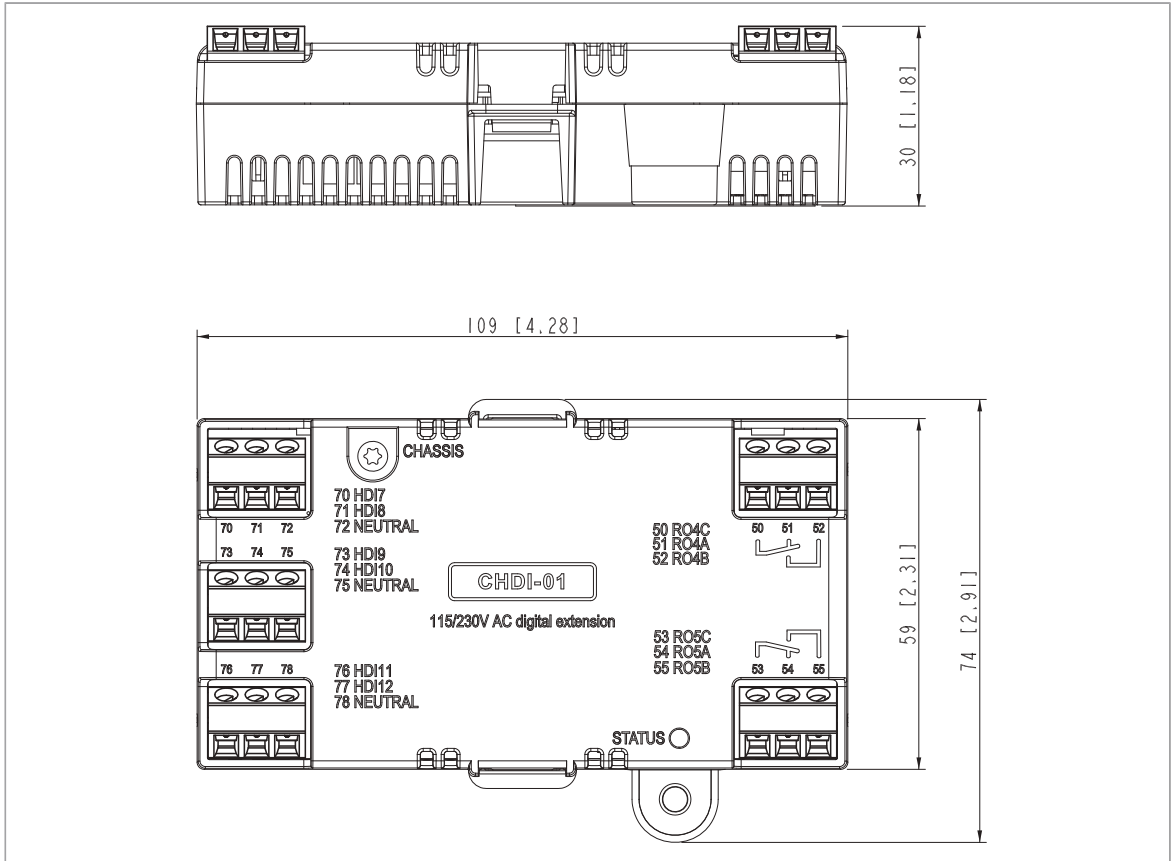





# 18

## **CMOD-01 multifunction extension module (external 24 V AC/DC and digital I/O)**

---

### **Contents of this chapter**

This chapter describes how to install and start up the optional CMOD-01 multifunction extension module. The chapter also contains diagnostics and technical data.

### **Product overview**

The CMOD-01 multifunction extension module (external 24 V AC/DC and digital I/O) expands the outputs of the drive control unit. It has two relay outputs and one transistor output, which can operate as a digital or frequency output.

In addition, the extension module has an external power supply interface, which can be used to power up the drive control unit in case the drive power supply is not on. If you do not need the backup power supply, you do not have to connect it because the module is powered from the drive control unit by default.

With CCU-24 control unit, a CMOD-01 module is not necessary for external 24 V AC/DC supply connection. The external supply is connected directly to terminals 40 and 41 on the control unit.

---

## Layout and example connections

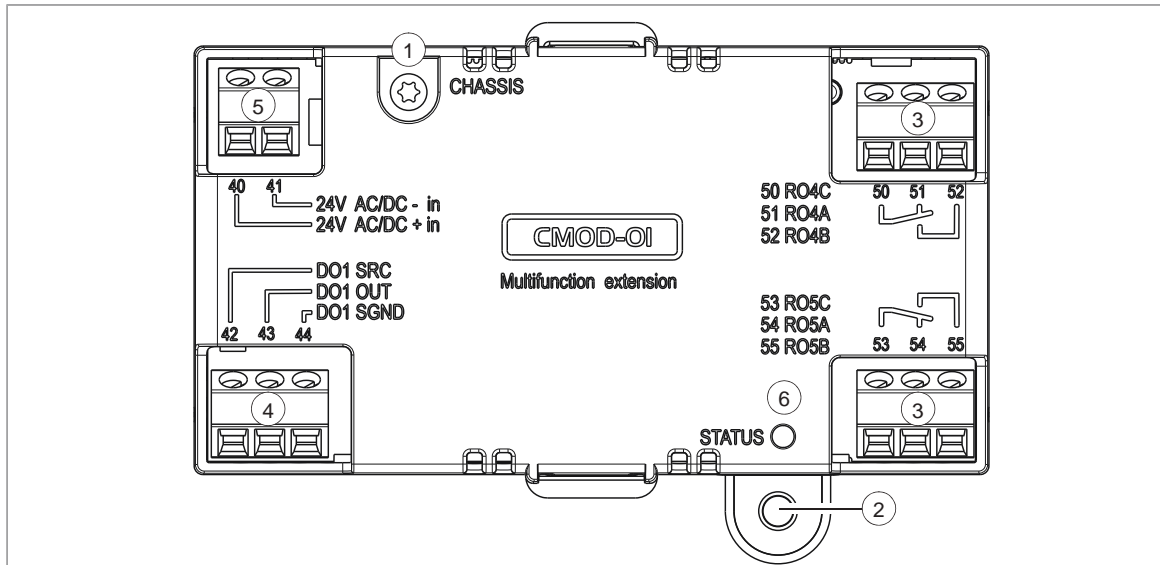

|          |   |                             |          |  |
|----------|---|-----------------------------|----------|--|
| <b>1</b> | <b>Grounding screw</b>                                |                             | <b>6</b> | <b>Diagnostic LED</b>                          |
| <b>2</b> | <b>Hole for mounting screw</b>                        |                             |          |  |
| <b>5</b> | <b>2-pin terminal block for external power supply</b> |                             | <b>3</b> | <b>3-pin terminal blocks for relay outputs</b> |
|          |   |                             |          |  |
| 40       | 24 V AC/DC + in                                       | External 24 V (AC/DC) input | 50       | RO4C<br>Common, C                              |
| 41       | 24 V AC/DC - in                                       | External 24 V (AC/DC) input | 51       | RO4A<br>Normally closed, NC                    |
| <b>4</b> | <b>3-pin terminal block for for transistor output</b> |                             | 52       | RO4B<br>Normally open, NO                      |
|          |   |                             |          |  |
|          |   |                             |          |  |
| 42       | DO1 SRC   | Source input                | 53       | RO5C<br>Common, C                              |
| 43       | DO1 OUT   | Digital or frequency output | 54       | RO5A<br>Normally closed, NC                    |
| 44       | DO1 SGND  | Ground (earth) potential    | 55       | RO5B<br>Normally open, NO                      |

1) Digital output connection example

2) An externally supplied frequency indicator which provides, for example:

- a 40 mA / 12 V DC power supply for the sensor circuit (CMOD frequency output)
- suitable voltage pulse input (10 Hz ... 16 kHz).

## Mechanical installation

### ■ Necessary tools

- Screwdriver and a set of suitable bits.

### ■ Unpacking and examining the delivery

1. Open the option package. Make sure that the package contains:
  - the option module
  - a mounting screw.
2. Make sure that there are no signs of damage.

### ■ Installing the module

See section [Installing option modules \(page 128\)](#).

## Electrical installation



### **WARNING!**

Obey the safety instructions of the drive. If you ignore them, injury or death, or damage to the equipment can occur.

Stop the drive and do the steps in section [Electrical safety precautions \(page 18\)](#) before you start the work.

### ■ Necessary tools

- Screwdriver and a set of suitable bits

### ■ Wiring

Connect the external control cables to the applicable module terminals. Ground the outer shield of the control cables at the cabinet entry.



### **WARNING!**

Do not connect the +24 V AC cable to the control unit ground when the control unit is powered using an external 24 V AC supply.

## Start-up

### ■ Setting the parameters

1. Power up the drive.
2. If no warning is shown,
  - make sure that the value of both parameters 15.01 Extension module type and 15.02 Detected extension module is CMOD-01.

If the warning A7AB Extension I/O configuration failure is shown,

- make sure that the value of parameter 15.02 is CMOD-01.
- set the parameter 15.01 value to CMOD-01.

You can now see the parameters of the extension module in parameter group 15 I/O extension module.

3. Set the parameters of the extension module to applicable values.

308 CMOD-01 multifunction extension module (external 24 V AC/DC and digital I/O)

Examples are given below.

#### Parameter setting example for relay output

This example shows how make relay output RO4 of the extension module indicate the reverse direction of rotation of the motor with a one-second delay.

| Parameter           | Setting |
|---------------------|---------|
| 15.07 RO4 source    | Reverse |
| 15.08 RO4 ON delay  | 1 s     |
| 15.09 RO4 OFF delay | 1 s     |

#### Parameter setting example for digital output

This example shows how to make digital output DO1 of the extension module indicate the reverse direction of rotation of the motor with a one-second delay.

| Parameter               | Setting        |
|-------------------------|----------------|
| 15.22 DO1 configuration | Digital output |
| 15.23 DO1 source        | Reverse        |
| 15.24 DO1 ON delay      | 1 s            |
| 15.25 DO1 OFF delay     | 1 s            |

#### Parameter setting example for frequency output

This example shows how to make digital output DO1 of the extension module indicate the motor speed 0...1500 rpm with a frequency range of 0...10000 Hz.

| Parameter                   | Setting                |
|-----------------------------|------------------------|
| 15.22 DO1 configuration     | Frequency output       |
| 15.33 Freq out 1 source     | 01.01 Motor speed used |
| 15.34 Freq out 1 src min    | 0                      |
| 15.35 Freq out 1 src max    | 1500.00                |
| 15.36 Freq out 1 at src min | 0 Hz                   |
| 15.37 Freq out 1 at src max | 10000 Hz               |

## ■ Diagnostics

### Faults and warning messages

Warning A7AB Extension I/O configuration failure.

### LEDs

The extension module has one diagnostic LED.

| Color | Description                         |
|-------|-------------------------------------|
| Green | The extension module is powered up. |

## Technical data

|                      |   |
|----------------------|---|
| Installation         | Into an option slot on the drive control unit |
| Degree of protection | IP20 / UL Type 1                              |

|   |  |
|---|--|
| Ambient conditions                      | See the drive technical data.              |
| Package                                 | Cardboard                                  |
| <b>Relay outputs (50...52, 53...55)</b> |  |
| Maximum wire size                       | 1.5 mm <sup>2</sup>                        |
| Minimum contact rating                  | 12 V / 10 mA                               |
| Maximum contact rating                  | 250 V AC / 30 V DC / 2 A                   |
| Maximum breaking capacity               | 1500 VA                                    |
| <b>Transistor output (42...44)</b>      |  |
| Maximum wire size                       | 1.5 mm <sup>2</sup>                        |
| Type                                    | Transistor output PNP                      |
| Maximum load                            | 4 kohm                                     |
| Maximum switching voltage               | 30 V DC                                    |
| Maximum switching current               | 100 mA / 30 V DC, short-circuit protected  |
| Frequency                               | 10 Hz ... 16 kHz                           |
| Resolution                              | 1 Hz                                       |
| Inaccuracy                              | 0.2%                                       |
| <b>External power supply (40...41)</b>  |  |
| Maximum wire size                       | 1.5 mm <sup>2</sup>                        |
| Input voltage                           | 24 V AC / V DC ±10% (GND, user potential)  |
| Maximum power consumption               | 25 W, 1.04 A at 24 V DC                    |
| <b>Isolation areas</b>                  |  |
|   |  |
| 1                                       | Plugged to drive <b>SLOT2</b>              |
|   | Reinforced insulation (IEC 61800-5-1:2007) |
|   | Functional insulation (IEC 61800-5-1:2007) |

## Dimension drawing

The dimensions are in millimeters and [inches].

310 CMOD-01 multifunction extension module (external 24 V AC/DC and digital I/O)

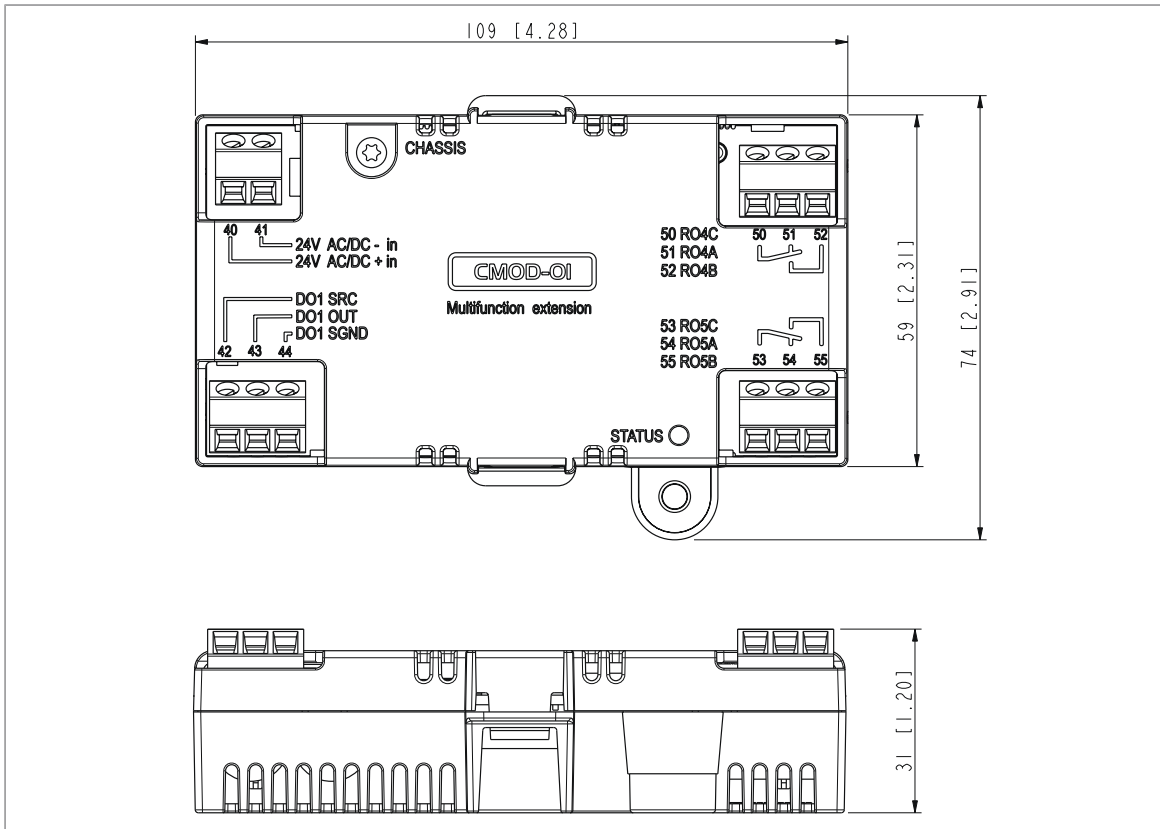

# 19

## **CMOD-02 multifunction extension module (external 24 V AC/DC and isolated PTC interface)**

---

### **Contents of this chapter**

This chapter describes how to install and start up the optional CMOD-02 multifunction extension module. The chapter also contains diagnostics and technical data.

### **Product overview**

The CMOD-02 multifunction extension module (external 24 V AC/DC and isolated PTC interface) has a motor thermistor connection for supervising the motor temperature and one relay output, which indicates the thermistor status. In case the thermistor overheats, the drive trips on motor overtemperature. If Safe torque off tripping is required, the user must wire the overtemperature indication relay to the certified Safe torque off input of the drive.

In addition, the extension module has an external power supply interface, which can be used to power up the drive control unit in case the drive power supply is not on. If you do not need the back-up power supply, you do not have to connect it because the module is powered from the drive control unit by default.

There is reinforced insulation between the motor thermistor connection, the relay output and the drive control unit interface. Thus, you can connect a motor thermistor to the drive through the extension module.

With CCU-24 control unit, a CMOD-02 module is not necessary for external 24 V AC/DC supply connection. The external supply is connected directly to terminals 40 and 41 on the control unit.

---

## Layout and example connections

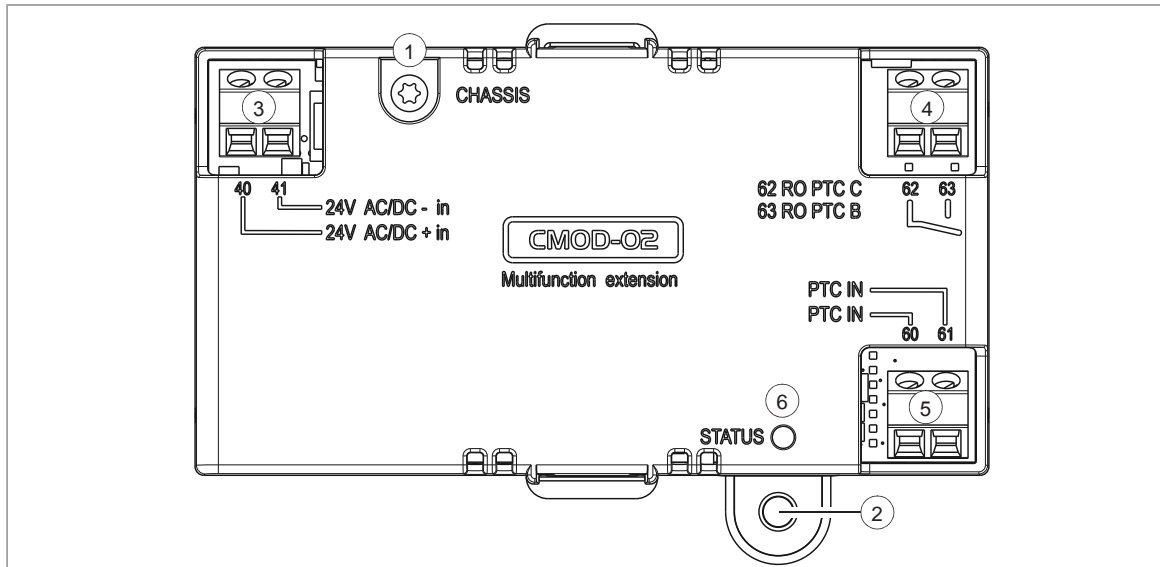

|          |                 |   |          |          |  |                                |
|----------|-----------------|---|----------|----------|--|--------------------------------|
| <b>3</b> |                 | <b>2-pin terminal block for external power supply</b> | <b>4</b> |          | <b>2-pin terminal block for relay output</b> |                                |
|          |                 |   |          |          |  |                                |
| 40       | 24 V AC/DC + in | External 24 V (AC/DC) input                           | 62       | RO PTC C | Common, C                                    |                                |
| 41       | 24 V AC/DC - in | External 24 V (AC/DC) input                           | 63       | RO PTC B | Normally open, NO                            |                                |
| <b>5</b> |                 | <b>Motor thermistor connection</b>                    | <b>1</b> |          |  | <b>Grounding screw</b>         |
|          |                 |   |          |          |  |                                |
|          |                 | One to six PTC thermistors connected in series.       |          |          |  |                                |
| 60       | PTC IN          | PTC connection  | <b>2</b> |          |  | <b>Hole for mounting screw</b> |
| 61       | PTC IN          | Ground (earth) potential                              | <b>6</b> |          |  | <b>Diagnostic LED</b>          |

## Mechanical installation

### ■ Necessary tools

- Screwdriver and a set of suitable bits.



### ■ Unpacking and examining the delivery

1. Open the option package. Make sure that the package contains:
  - the option module
  - a mounting screw.
2. Make sure that there are no signs of damage.

### ■ Installing the module

See section [Installing option modules \(page 128\)](#).

## Electrical installation

---



### **WARNING!**

Obey the safety instructions of the drive. If you ignore them, injury or death, or damage to the equipment can occur.

---

Stop the drive and do the steps in section [Electrical safety precautions \(page 18\)](#) before you start the work.

### ■ Necessary tools

- Screwdriver and a set of suitable bits

### ■ Wiring

Connect the external control cables to the applicable module terminals. Ground the outer shield of the control cables at the cabinet entry.

---



### **WARNING!**

Do not connect the +24 V AC cable to the control unit ground when the control unit is powered using an external 24 V AC supply.

---

## Start-up

### ■ Setting the parameters

1. Power up the drive.
2. If no warning is shown,
  - make sure that the values of both parameters 15.01 Extension module type and 15.02 Detected extension module are CMOD-02.

If the warning A7AB Extension I/O configuration failure is shown,

- make sure that the value of parameter 15.02 is CMOD-02.
- set the parameter 15.01 value to CMOD-02.

You can now see the parameters of the extension module in parameter group 15 I/O extension module.

## Diagnostics

### ■ Faults and warning messages

Warning A7AB Extension I/O configuration failure.

---

## ■ LEDs

The extension module has one diagnostic LED.

| Color | Description                         |
|-------|-------------------------------------|
| Green | The extension module is powered up. |

## Technical data

|   |  |
|---|--|
| Installation  | Into option slot 2 on the drive control unit |
| Degree of protection  | IP20 / UL Type 1                             |
| Ambient conditions  | See the drive technical data.                |
| Package   | Cardboard                                    |
| <b>Motor thermistor connection (60...61)</b>  |  |
| Maximum wire size   | 1.5 mm <sup>2</sup>                          |
| Supported standards   | DIN 44081 and DIN 44082                      |
| Triggering threshold  | 3.6 kohm ±10%                                |
| Recovery threshold  | 1.6 kohm ±10%                                |
| PTC terminal voltage  | ≤ 5.0 V                                      |
| PTC terminal current  | < 1 mA                                       |
| Short-circuit detection   | < 50 ohm ±10%                                |
| <p>The PTC input is reinforced/double insulated. If the motor part of the PTC sensor and wiring are reinforced/double insulated, voltages on the PTC wiring are within SELV limits.</p> <p>If the motor PTC circuit is not reinforced/double insulated (ie, it is basic insulated), it is mandatory to use reinforced/double insulated wiring between the motor PTC and CMOD-02 PTC terminal.</p> |  |
| <b>Relay output (62...63)</b>   |  |
| Maximum wire size   | 1.5 mm <sup>2</sup>                          |
| Maximum contact rating  | 250 V AC / 30 V DC / 5 A                     |
| Maximum breaking capacity   | 1000 VA                                      |
| <b>External power supply (40...41)</b>  |  |
| Maximum wire size   | 1.5 mm <sup>2</sup>                          |
| Input voltage   | 24 V AC / V DC ±10% (GND, user potential)    |
| Maximum power consumption   | 25 W, 1.04 A at 24 V DC                      |
| <b>Isolation areas</b>  |  |

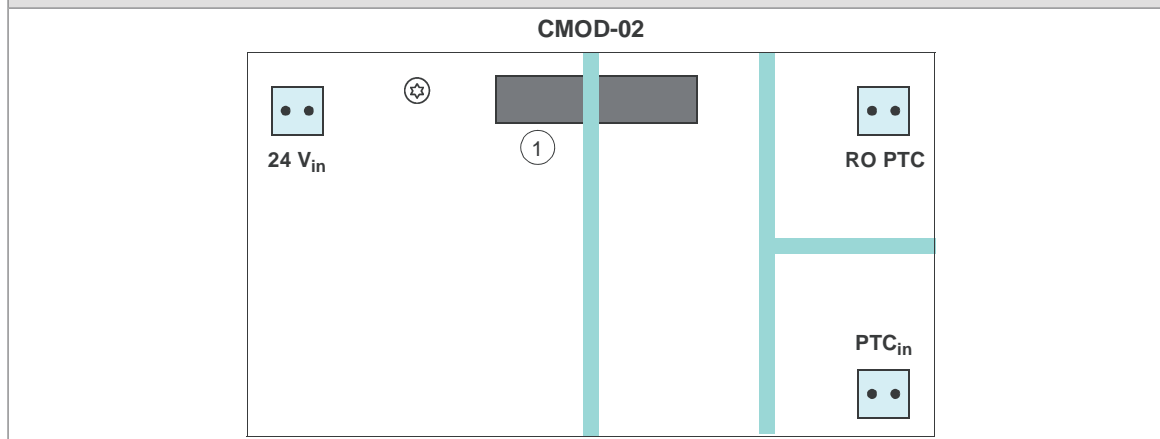

|       |  |
|-------|--|
| 1     | Plugged to drive <b>SLOT2</b>              |
| ■     | Reinforced insulation (IEC 61800-5-1:2007) |
| ■ ■ ■ | Functional insulation (IEC 61800-5-1:2007) |

## Dimension drawing

The dimensions are in millimeters and [inches].

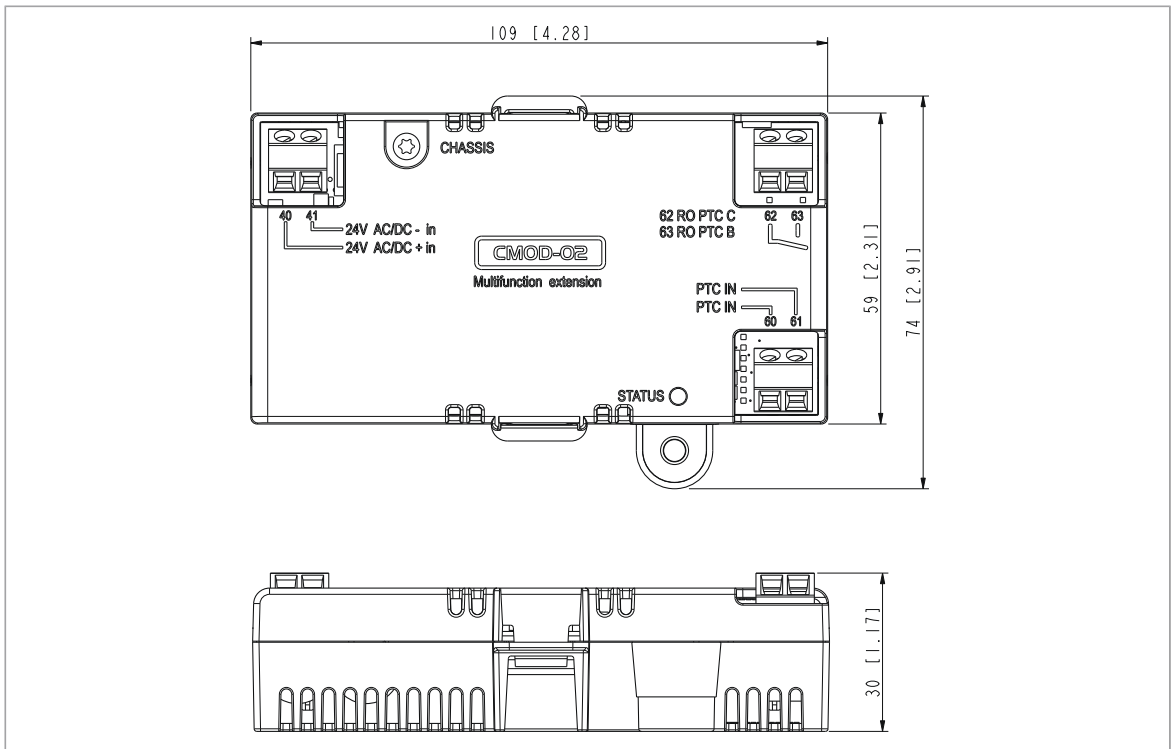



---

# Further information

## Product and service inquiries

Address any inquiries about the product to your local ABB representative, quoting the type designation and serial number of the unit in question. A listing of ABB sales, support and service contacts can be found by navigating to [www.abb.com/contact-centers](http://www.abb.com/contact-centers).

## Product training

For information on ABB product training, navigate to [new.abb.com/service/training](http://new.abb.com/service/training).

## Providing feedback on ABB manuals

Your comments on our manuals are welcome. Navigate to [forms.abb.com/form-26567](http://forms.abb.com/form-26567).

## Document library on the Internet

You can find manuals and other product documents in PDF format on the Internet at [www.abb.com/drives/documents](http://www.abb.com/drives/documents).



[www.abb.com/drives](http://www.abb.com/drives)



3AXD50000045816G