

—
OPERATING INSTRUCTION

Control panels CP600 2nd generation CP6407, CP6410, CP6415





Contents

1	Introduction	3
2	Safety guide	4
2.1	Safety guide	4
2.2	Safety notices	4
2.3	Markups	5
3	Product overview	6
4	Standards and approvals	7
4.1	Product identification	7
5	Technical specifications	9
6	Technical data	11
6.1	Dimensions	12
6.2	Installation environment	13
6.3	Safety instruction	14
6.4	Installation procedure	14
7	Connections	15
7.1	CP600 2nd generation	15
7.2	Serial port	16
7.3	Ethernet port	16
8	Power supply, grounding and shielding	17
9	Battery	19
9.1	Dispose of batteries	19
10	Special instruction for use	20
11	Cleaning faceplates	20
12	Getting started	20
13	System settings	21
14	Unpacking and packing instructions	23

1 Introduction

The operational guidelines described below are information on device technical data, installation, transportation, storage, assembly, use and maintenance.

The Manual refers to the following models:

Picture	Type	Description
	CP6407	Operator interface with 7" color widescreen display and resistive touchscreen
	CP6410	Operator interface with 10"4 color display and resistive touchscre
	CP6415	Operator interface with 15" color display and resistive touchscreen

2 Safety guide

2.1 Safety guide

The manual contains safety standards that must be respected for the personal safety and to avoid damage.

Indications of attention are divided into three levels of severity.

2.2 Safety notices



DANGER!

Indicates an imminent risk. It will lead to death or serious injury if not avoided.



WARNING!

Indicates a possible risk. It may lead to death or serious injury if not avoided.



CAUTION!

Indicates a possible risk. It may lead to light or slight injury or material damage if not avoided.

2.3 Markups

- Enumeration.
- ✓ Precondition for an operation instruction or a description.
- Operation instruction with one step.
- 1. Operation instruction with several steps.
 - Result of an operation.



NOTE

Helpful information with background information or an emphasized notice.



TIP

Application tips or other useful information and suggestions.

3 Product overview

CP600 2nd generation HMI products combine state-of-the-art features and great performance in a compact and robust design.

They have been designed to offer competitive price/performance ratio for challenging industrial applications where robust devices are a requirement.

These products feature a full die-cast aluminum housing. Compatibility with CP600 series cut-out offers an easy upgrade path for the old series.

CP600 2nd generation products have been designed to run PB610 software with outstanding communication and graphical options.

- Efficient and secure Linux operating system
- Gateway function with Server and Client OPC UA
- aFull PB610 vector graphic support
- Efficient unified programming strategy for web HMI applications

4 Standards and approvals

The products have been designed for use in an industrial environment in compliance with the 2014/30/EU EMC Directive.

The products have been designed in compliance with:

EN 61000-6-4
 EN 61000-6-2 EN 61000-4-2
 EN 61000-4-3
 EN 61000-4-4
 EN 61000-4-5
 EN 61000-4-6
 EN 61000-4-8
 EN 61000-4-29
 EN60945

The installation of these devices into the residential, commercial and light-industrial environments is allowed only in the case that special in measures are taken in order to ensure conformity to EN 61000-6-3.

The products are in compliance with the Restrictions on Certain Hazardous Substances (RoHS) Directive 2011/65/EU

In compliance with the above regulations the products are CE marked.



NOTE

If the mounting surface is not plane and robust enough, the degree IP69K is not guaranteed.

A special mounting flange is included to provide the necessary support.

4.1 Product identification

The product may be identified through a plate attached to the rear cover. You will have to know the type of unit you are using for correct usage of the information contained in the guide.

An example of this plate is shown in the figure below:

Note: the CP6407 label is used as an example for CP600 2nd generation Series.



NOTE

The CP6407 label is used as an example for CP600 2nd generation Series.

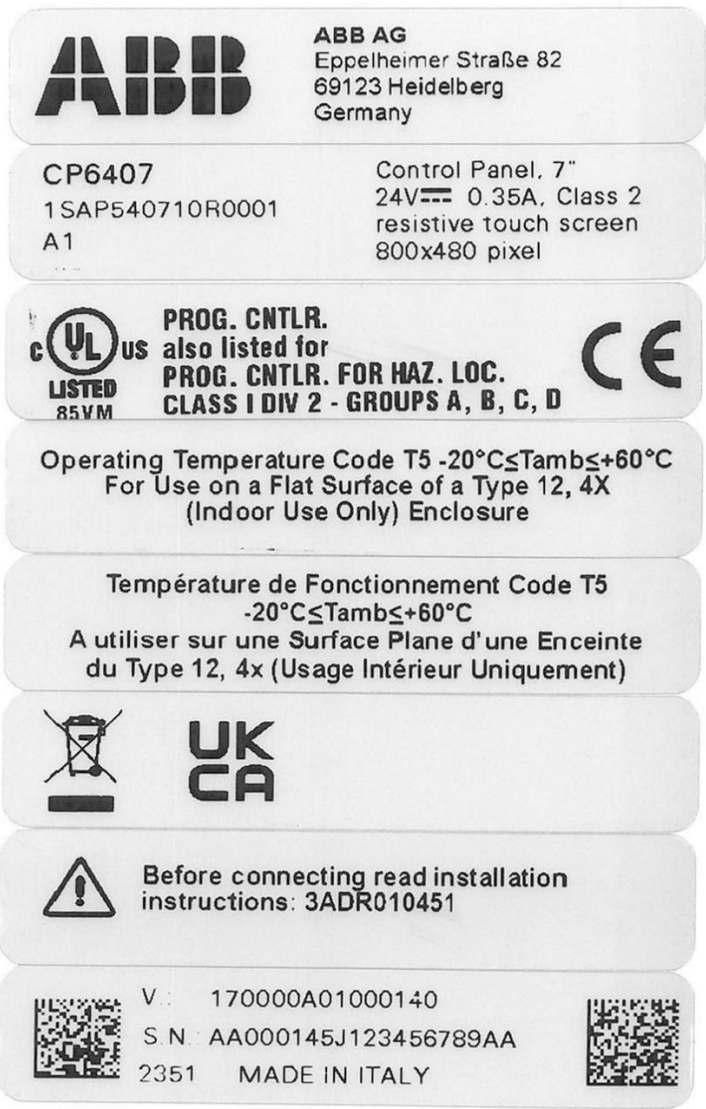

Information on type plate (example)	Description
Product model name	CP6407
Product part number	1SAP540710R0001
Serial number	S.N.: AAxxxxxxxxxxxxxxxxxxAA
Product version ID	V.: xxxxxxxxxxxxxxxx
Manufacturer address	ABB AG Eppelheimer Straße 82, 69123 Heidelberg Germany

5 Technical specifications

Touchscreen technology	Resistive	
Back-up battery	3 V 50 mAh Lithium, rechargeable, not user-replaceable, model VL2330.	
Fuse	Automatic	
Serial port	RS-232, RS-485, RS-422 software configurable	
Flash	4 GB	
RAM	512 MB	
Hardware clock	Clock/Calendar with back-up battery	
Accuracy RTC (at 25°C)	< 100 ppm	
Environmental conditions		
Operating temperature	-20 ... +60 °C (vertical installation)	EN 60068-2-14
Storage temperature	-20 ... +70 °C	EN 60068-2-1 EN 60068-2-2 EN 60068-2-14
Operating and storage humidity	5 ... 85 % RH not-condensing	EN 60068-2-30
Vibrations	5 ... 9 Hz, 7 mm; 9 ... 150 Hz, 1 g ^{D-P}	EN 60068-2-6
Shock	± 50 g, 11 ms, 3 pulses per axis	EN 60068-2-27
Protection class	Front panel IP66, Rear IP20	EN 60529
Electromagnetic Compatibility (EMC)		
Electrostatic discharge immunity test	8 kV (air electrostatic discharge) 4 kV (contact electrostatic discharge)	EN 61000-4-2
Radiated, radio-frequency, electromagnetic field immunity test	80 MHz ... 1 GHz, 10 V/m 1.4 GHz ... 2 GHz, 3 V/m 2 GHz ... 2.7 GHz, 1 V/m	EN 61000-4-3
Burst immunity test	±2 kV DC power port ±1 kV signal line	EN 61000-4-4
Surge immunity test	±0,5 kV DC power port (line to earth) ± 1 KV dc power port (line to line) ±1 kV signal line (line to earth)	EN 61000-4-5
Immunity to conducted disturbances induced by radiofrequency field	0.15...80 MHz, 10 V	EN 61000-4-6
Power frequency magnetic field immunity test	Enclosure, 50 Hz, 30 A/m	EN 61000-4-8

Voltage dips, short interruptions and voltage variations immunity test	Port: DC mains; Level: 0% duration: 10 ms 20 spaces by 1 s Test executed on the 24 VDC of the EUT	EN 61000-4-29
-------------------------------------------------------------------------------	---------------------------------------------------------------------------------------------------------	---------------

Durability information

Backlight service life (LED type)	40000 hr. or more (Time of continues operation until the brightness of the backlight reaches 50 % of the rated value when the ambient temperature is 25 °C) - see Note 1
------------------------------------------	-----------------------------------------------------------------------------------------------------------------------------------------------------------------------------

Note 1: Extended use in environments where the ambient temperature is 40 °C or higher may degrade backlight quality/reliability/durability.

6 Technical data

Model	CP6407	CP6410	CP6415
Display	TFT Color / LED	TFT Color / LED	TFT Color / LED
Colors	64K	64K	64K
Resolution	800X480	800X600	1024X768
Diagonal	7" widescreen	10.4"	15"
Dimming	yes	yes	yes
Flash	4GB	4GB	4GB
SD card slot	yes	yes	yes
RAM	512MB	512MB	512MB
Serial port	RS-232,RS-485, RS-422 software configurable	RS-232,RS-485, RS-422 software configurable	RS-232,RS-485, RS-422 software configurable
Ethernet port	2 10/100Mb	2 10/100Mb	2 10/100Mb
USB port	2 Host interface version 2.0 1 max. 100mA, 1 max. 500mA	2 Host interface version 2.0 1 max. 100mA, 1 max. 500mA	2 Host interface version 2.0 1 max. 100mA, 1 max. 500mA
Battery	rechargeable	rechargeable	rechargeable
RTC	yes	yes	yes
Voltage	24Vdc (*)	24Vdc (*)	24Vdc (*)
Current rating at 24Vdc	0.35A	0.40A	0.70A
Weight	1.0 Kg	2.0 Kg	3.5 Kg

* 10-32Vdc

For applications requiring compliance with EN 61131-2 and specifically in reference to 10 ms voltage dips, the power supply range voltage is 18-32Vdc.

6.1 Dimensions

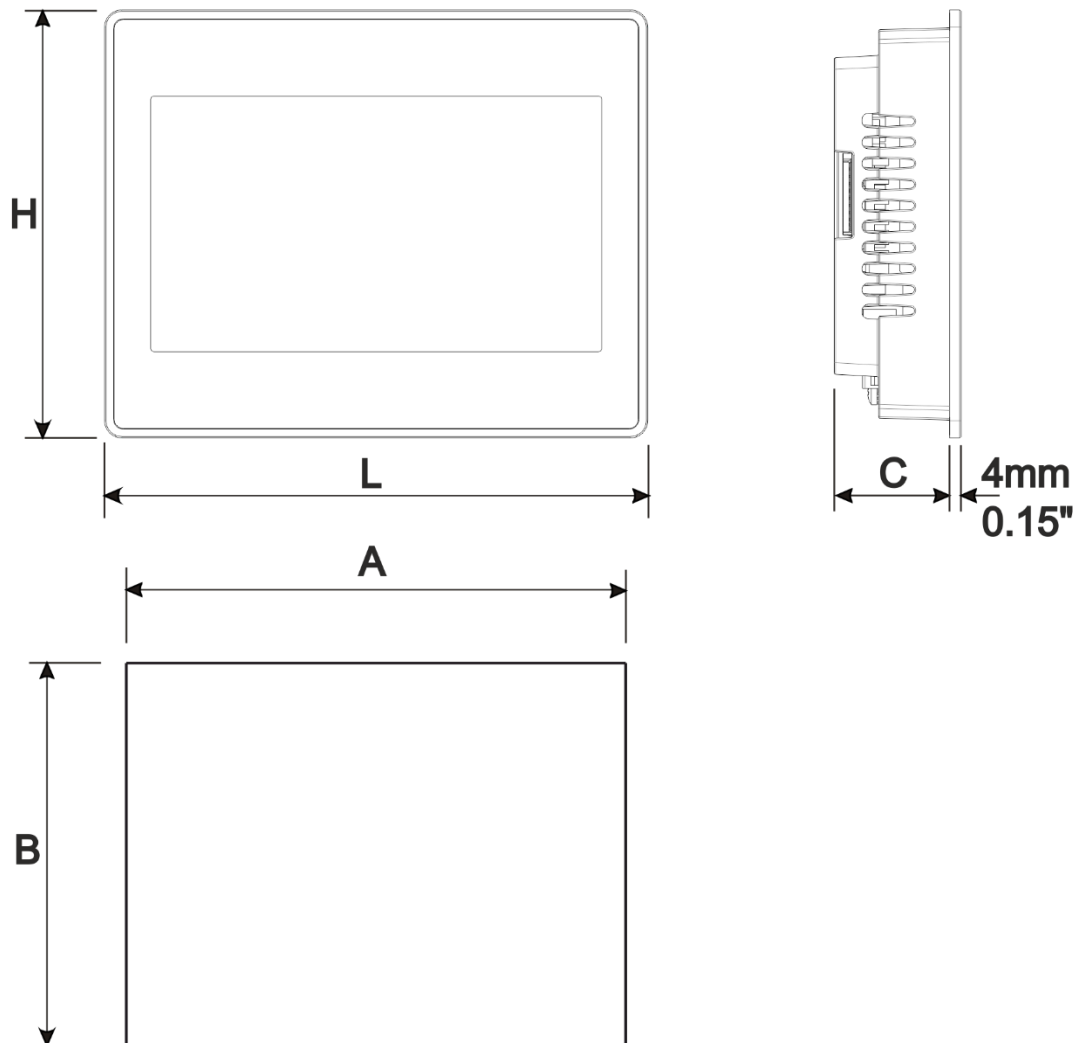

	A	B	C	H	L
CP6407	176 mm 6.92"	136 mm 5.35"	40 mm 1.57"	147,5 mm 5.80"	187,5 mm 7.38"
CP6410	276 mm 10.86"	221 mm 8.70"	40 mm 1.57"	232,5 mm 9.15"	287,5 mm 11.31"
CP6415	381 mm 15"	296 mm 11.65"	45 mm 1.77"	307,5 mm 12.10"	392,5 mm 15.45"

6.2 Installation environment

Avoid prolonged exposition to direct sunlight to avoid the risk of overheating the device.

The equipment is not intended for installation in contact with corrosive chemical compounds. Check the resistance of the front panel to a specific compound before installation.

Do not use tools of any kind (screwdrivers, etc.) to operate the touch screen of the panel.

In order to meet the front panel protection classifications, proper installation procedure must be followed:

- The borders of the cutout must be flat
- Screw up each fixing screw until the bezel corner get in contact with the panel.
- The cutout for the panel must be of the dimensions indicated in this manual.

The IP66 is guaranteed only if:

- Max deviation from the plane surface to the cut-out: ≤ 0.5 mm
- Thickness of the case where is mounted the equipment: from 1.5 mm to 6 mm
- Max surface roughness where the gasket is applied: ≤ 120 μm

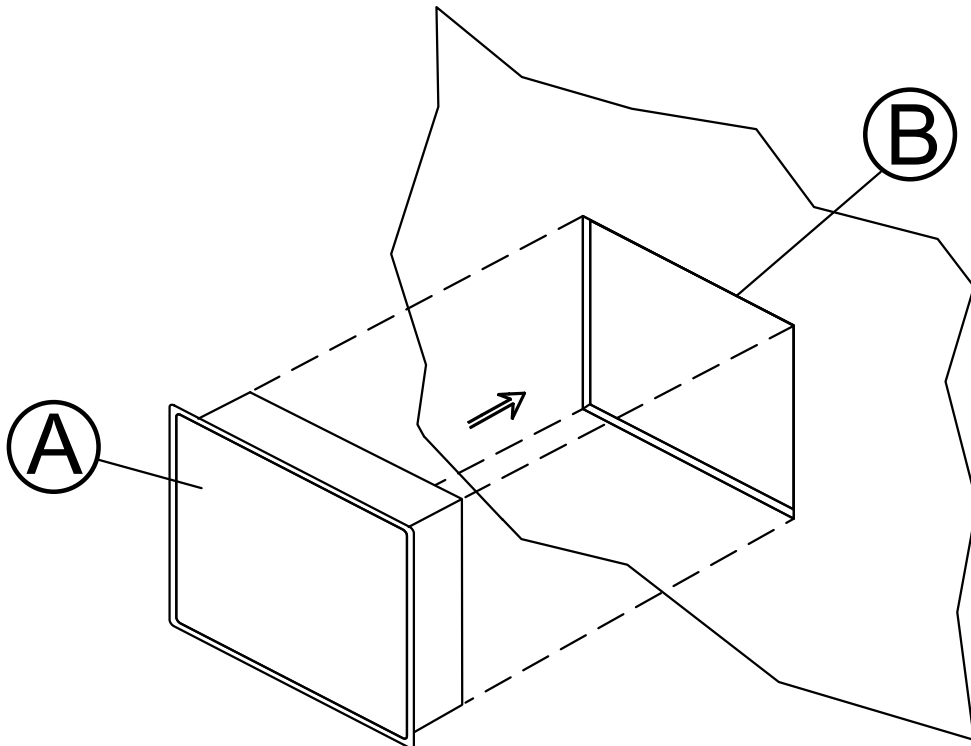

- A. CP64xx
- B. Installation cut-out

6.3 Safety instruction



CAUTION!

For all installation notes, please refer to the Installation Instruction provided with the product.

6.4 Installation procedure

Place the fixing brackets contained in the fixing kit as shown in figure.

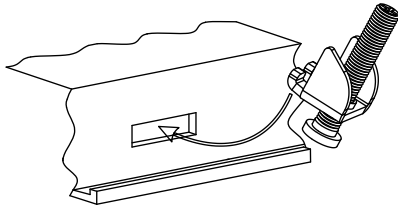

CAUTION!

Tightening torque: 130 Ncm or screw each fixing screw until the bezel corner gets in contact with the panel.

7 Connections

7.1 CP600 2nd generation

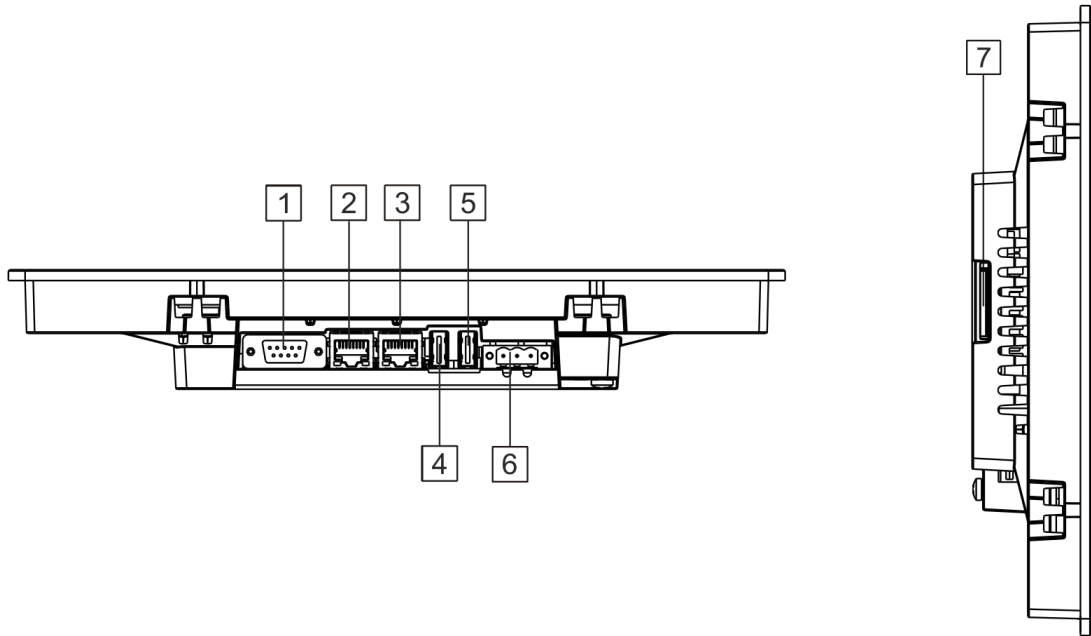

1. Serial port
2. Ethernet Port 0
3. Ethernet Port 1
4. USB Port V2.0, max. 500 mA
5. USB Port V2.0, max. 100 mA
6. Power Supply
7. SD Card Slot

7.2 Serial port

The serial port is used to communicate with the PLC or with another type of controller. Different electrical standards are available for the signals in the PLC port connector: RS-232, RS-422, and RS-485.

The serial port is software programmable. Make sure you select the appropriate interface in the programming software.

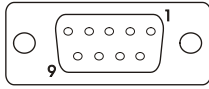

Pin	RS-232	RS-422, RS-485
1	GND	GND
2		
3	TX	CHA-
4	RX	CHB-
5		
6	+5V output	+5V output
7	CTS	CHB+
8	RTS	CHA+
9		

To operate in RS-485 pins 7-8 and 3-4 must be connected externally.

The communication cable must be chosen for the type of device being connected.

7.3 Ethernet port

The Ethernet port has two status indicators. Please see description in figure.

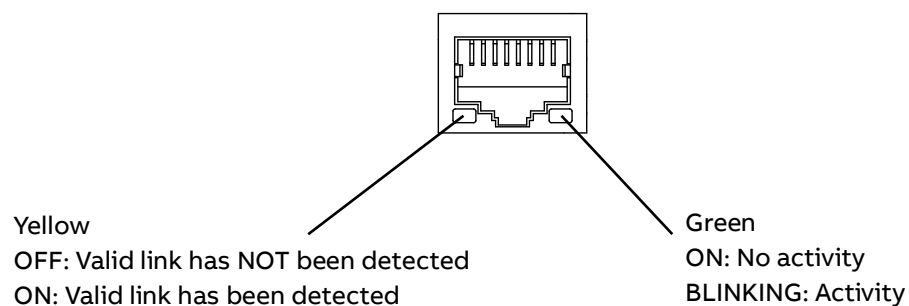

8 Power supply, grounding and shielding

The power supply terminal block is shown in the figure below.

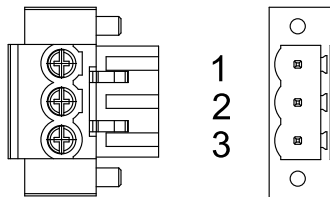

Pin	Description
1	+24 V DC (L+)
2	Common (M)
3	Ground

3 conductors 1,5 mm² wire size minimum, minimum temperature conductor rating 105 °C.



NOTE

Ensure that the power supply has enough power capacity for the operation of the equipment.

The unit must always be grounded to earth with 1,5 mm² wire size minimum. Grounding helps limit the effects of noise due to electromagnetic interference on the control system.

Earth connection will have to be done using either the screw or the faston terminal located near the power supply terminal block. A label helps identify the ground connection. Also connect to ground the terminal 3 on the power supply terminal block.

The power supply circuit may be floating or grounded. In the latter case, connect to ground the power source common as shown in figure (see below) with a dashed line. When using the floating power scheme, note that the panes internally connects the power common to ground with a 1 MΩ resistor in parallel with a 4,7 nF capacitor. The power supply must have double or reinforced insulation. The suggested wiring for the power supply is shown below.

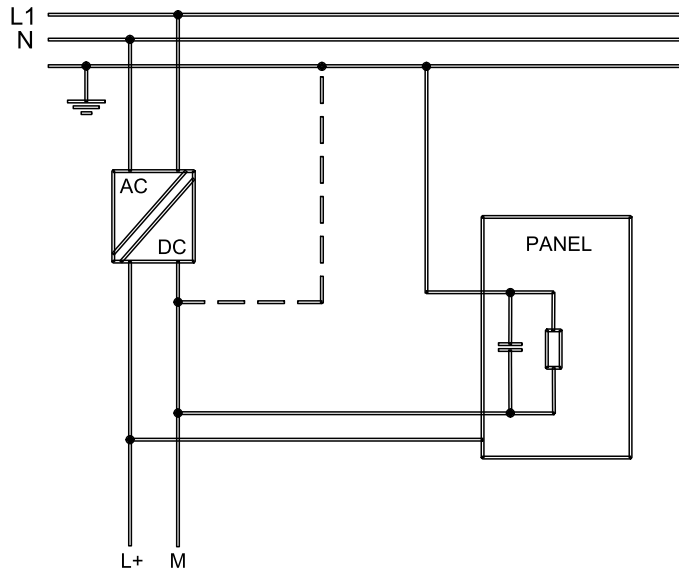

All the electronic devices in the control system must be properly grounded.
 Grounding must be performed according to applicable regulations.

9 Battery

CP600 2nd generation panels are equipped with rechargeable Lithium battery, not user-replaceable.

The hardware real-time clock (date and time) is maintained by the battery.



CAUTION!

At the first installation, CP600 2nd generation panels shall be charged for 48 hours.

When the battery is fully charged, it ensures a period of 3 months of data backup at 25 °C.

Location of the battery: See “broken circle” in the picture below.

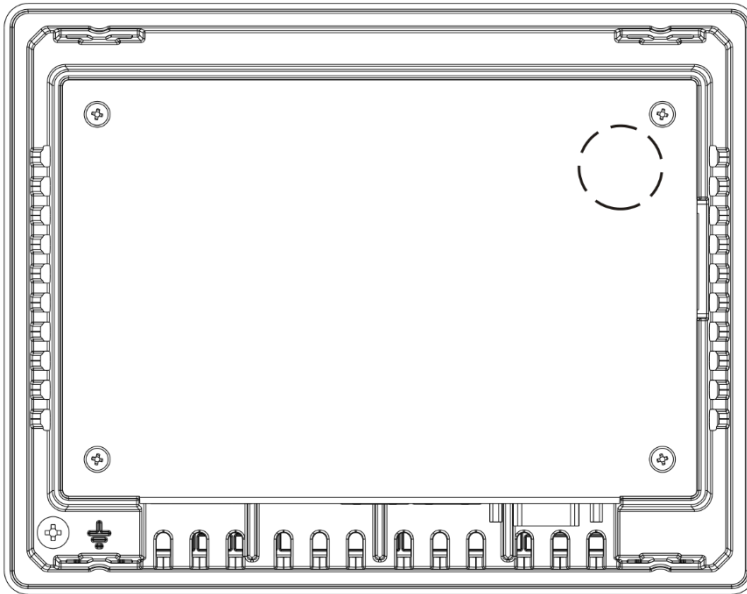

9.1 Dispose of batteries



NOTE

The battery must not be disposed as unsorted domestic waste.

Dispose of batteries according to the local regulations.



10 Special instruction for use

- Install the HMI device according to the accompanying installation instructions.
- Ground the HMI device according to the accompanying installation instructions.
- Only qualified personnel may install the HMI device or repair it.
- Ensure that the aeration holes are not covered.
- Care shall be taken not to allow layers of dust to form on the faceplate of the HMI device in a way that might cause the accumulation of static charges.
Keep the faceplate of the HMI device clean: the equipment must be cleaned only with a soft cloth and neutral soap product. Do not use solvents.
- This device should not be used for purposes and methods other than indicated in this document and in the documentation accompanying the product.

11 Cleaning faceplates



CAUTION!

The equipment must be cleaned only with a soft cloth and neutral soap product.

Do not use solvents.

12 Getting started

CP600 2nd generation control panels must be programmed with the software PB610. PB610 Panel Builder is a software tool that must be properly installed on a computer running Microsoft Windows.

There are two options to transfer a PB610 application project to a CP600 2nd generation device:

- | | |
|----------|---------------------------------------------------------------------------------------------------------------------------------------------------------------------------------------------------------------------------------------------------------------------------------------------------|
| Ethernet | Connect the CP600 2nd generation device to the computer with an Ethernet network connection. From PB610 choose the command Run/Download to target. You may have to ensure that the proper firewall policy has been configured in the computer to allow PB610 Panel Builder to access the network. |
| USB | Create an Update Package using PB610 Panel Builder and copy it to a USB Flash drive. |

13 System settings

CP600 2nd generation control panels have a system settings interface to allow configuration of system options.

The user interface of System Settings is based on HTML pages accessible locally on CP600 or in remote using a Web browser Chrome v44 or higher on port 443

(https://IP/machine_config). Default username is “admin”, default password is “admin”.

Use navigation menu on the left side of the screen to browse through the available options.

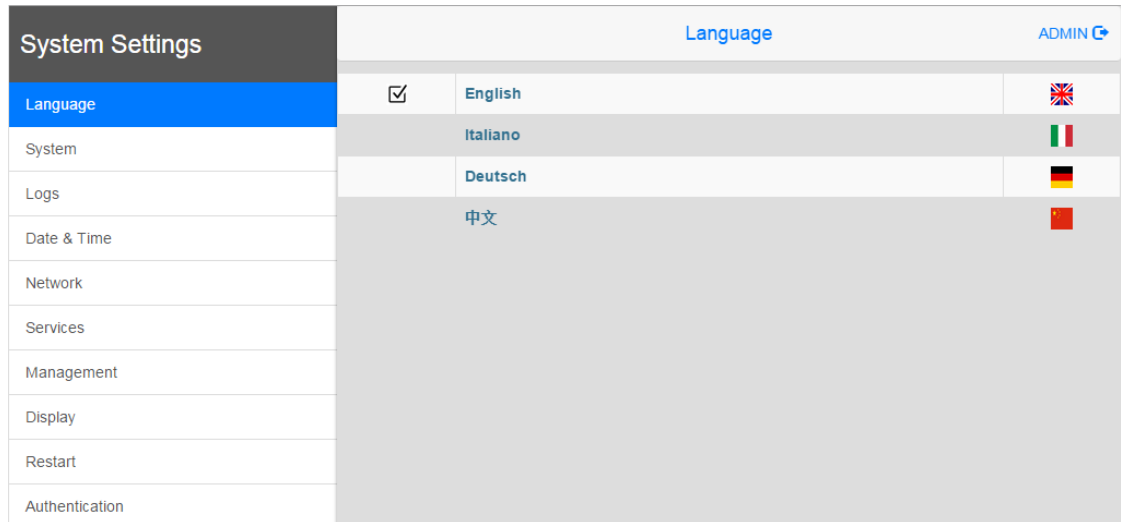

The active item of menu is highlighted on the left side. The right side shows related information and settings. Based on the size of the CP600 2nd generation screen, both menu and content of selected item may be shown on screen or not.

Two modes of operation can be selected in the System Settings:

- | | |
|--------------------|--------------------------------------------------------------------------------------------------------------------------------------------------------------------------------------------------------------------------------------------------------------------|
| User Mode | PB610 runtime is running or the CP600 2nd generation device is in “factory default” status. |
| System Mode | PB610 runtime is not running or the CP600 2nd generation device has a software failure. System Mode includes all options available in User Mode and offers in additions commands dedicated to system upgrade and recovery not available when running in User Mode. |

Activation of System Settings in User Mode:

- | | |
|----------------------------------|--------------------------------------------------------------------------------------------------------------------------------------------------------------------------------------|
| PB610 runtime not running | Press “System Setting” button on the CP600 2nd generation screen. |
| PB610 runtime running | Recall context menu and select “System Settings”. To recall the context menu click and hold any unused area of the touchscreen for a few seconds.
Default hold time is 2 seconds. |

Activation of System Settings in System Mode:

Normal operation	<p>If PB610 runtime is not running: Press “System Setting” button on the CP600 2nd generation screen to enter in System Settings in User Mode.</p> <p>Select “Restart” → “Config OS” to reboot in System Mode.</p> <p>If PB610 runtime is running: recall context menu and select “System Settings”. To recall the context menu click and hold any unused area of the touchscreen for a few seconds.</p> <p>Default hold time is 2 seconds to enter in System Settings in User Mode.</p> <p>Select “Restart” → “Config OS” to reboot in System Mode.</p>
Recovery operation	<p>If panel is not responsive, use the so-called “tap-tap” procedure. This procedure consists in tapping the surface of the touchscreen during the device power-up phase. Tapping frequency must be high. You have to start tapping the touchscreen as soon as power has been applied to the device. When the sequence has been recognized, the system shows the message: “TAP-TAP DETECTED”. At this point release touch to boot in User Mode without running PB610 runtime or press and hold few seconds (selecting so “RESTART: CONFIG OS”) to boot in System Mode.</p>

System Settings includes options for basic settings of the device.

Language	Configure language used for System Settings menu only.
System	Show information about platform, status and timers (e.g. System on time, backlight on time).
Logs	Enable persistent log for BSP and allows to export it.
Date & Time	Change the device date and time, including time zone and NTP Server
Network	Configure IP Address of Ethernet interface and the other network settings like DNS, Gateway, DHCP, Hostname, routing and bridging.
Services	Enable/disable services. Example of services are: Open SSH server, Cloud services, SNMP and logging.
Management	Update of BSP components (Main OS, Config OS, Boot loader, XLoader), check for partitions consistence, update of splash screen, information about usage and size of partitions. The update of Main OS is available only in System Mode, the update of Config OS is only in User Mode.
Display	Adjust brightness, configure automatic backlight turnoff and select CP600 2nd generation orientation (90°, 180°, 270° and 360°).
Restart	Restart the device. “Main OS” option restarts as per default in User Mode, “Config OS” option restart panel directly into System Settings in System Mode.
Authentication	Configure password for administrator (“admin”) and for the standard user (“user”). Administrator has full access to System Settings (updates of BSP and other system components). Standard user has some limitations.

14 Unpacking and packing instructions

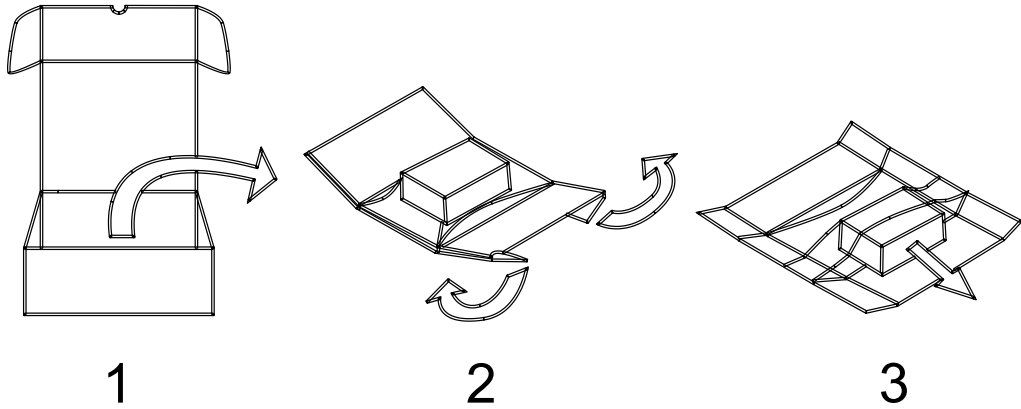

NOTE

To repack the unit, please follow the instructions backwards.

—

ABB AG

new.abb.com/plc

—

Copyright (c) 2018 – 2024 ABB.
All rights reserved. Subject to alterations.