

SIEMENS

MICROMASTER 430

Parameter List

Issue 07/05



Available Documentation for the MICROMASTER 430

Getting Started Guide

Is for quick commissioning with SDP and BOP-2.



Operating Instructions

Gives information about features of the MICROMASTER 430, Installation, Commissioning, Control modes, System Parameter structure, Troubleshooting, Specifications and available options of the MICROMASTER 430.



Parameter List

The Parameter List contains the description of all Parameters structured in functional order and a detailed description. The Parameter list also includes a series of function plans.



Catalogues

In the catalogue you will find all needs to select a certain inverter, as well as filters chokes, operator panels or communications options.





Warning

Please refer to all Definitions and Warnings contained in the Operating Instructions. You will find the Operating Instructions on the Docu CD delivered with your inverter. If the CD is lost, it can be ordered via your local Siemens department under the Order No. 6SE6400-5AD00-1AP0.

Information about MICROMASTER 430 is also available from:

Regional Contacts

Please get in touch with your contact for Technical Support in your Region for questions about services, prices and conditions of Technical Support.

Central Technical Support

The competent consulting service for technical issues with a broad range of requirements-based services around our products and systems.

Europe / Africa

Tel: +49 (0) 180 5050 222

Fax: +49 (0) 180 5050 223

Email: adsupport@siemens.com

America

Tel: +1 423 262 2522

Fax: +1 423 262 2589

Email: simatic.hotline@sea.siemens.com

Asia / Pacific

Tel: +86 1064 757 575

Fax: +86 1064 747 474

Email: adsupport.asia@siemens.com

Online Service & Support

The comprehensive, generally available information system over the Internet, from product support to service & support to the support tools in the shop.

<http://www.siemens.com/automation/service&support>

Internet Address

Customers can access technical and general information under the following address:

<http://www.siemens.com/micromaster>

Printed in the Federal Republic of Germany

Siemens-Aktiengesellschaft.

Approved Siemens Quality for Software and Training is to DIN ISO 9001, Reg. No. 2160-01

Other functions not described in this document may be available. However, this fact shall not constitute an obligation to supply such functions with a new control, or when servicing.

The reproduction, transmission or use of this document, or its contents is not permitted unless authorized in writing. Offenders will be liable for damages. All rights including rights created by patent grant or registration of a utility model or design are reserved.

We have checked that the contents of this document correspond to the hardware and software described. There may be discrepancies nevertheless, and no guarantee can be given that they are completely identical. The information contained in this document is reviewed regularly and any necessary changes will be included in the next edition. We welcome suggestions for improvement.

© Siemens AG 2002 - 2005 All Rights Reserved.

MICROMASTER® is a registered trademark of Siemens

Siemens handbooks are printed on chlorine-free paper that has been produced from managed sustainable forests. No solvents have been used in the printing or binding process. Document subject to change without prior notice.

Printed in the Federal Republic of Germany

Siemens-Aktiengesellschaft.

Parameters MICROMASTER 430

This Parameter List must only be used together with the Operating Instructions of the MICROMASTER 430. Please pay special attention to the Warnings, Cautions, Notices and Notes contained in these manuals.

Table of Contents

1	Block Diagram and Terminals	7
1.1	Block Diagram	7
1.2	Power Terminals	8
1.3	Control Terminals	11
2	Parameters	12
2.1	Introduction to MICROMASTER System Parameters	12
2.2	Quick commissioning (P0010 = 1)	15
2.3	Command and Drive Datasets - Overview	17
2.4	Binector Input Parameters	21
2.5	Connector Input Parameters	22
2.6	Binector Output Parameters	22
2.7	Connector Output Parameters	23
2.8	Connector/Binector Output Parameters	23
3	Parameter Description	24
3.1	Common parameters	24
3.2	Diagnosis parameters	28
3.3	Inverter parameters (HW)	37
3.4	Motor parameters	41
3.5	Speed encoder	49
3.6	Application macros	51
3.7	Motor temperature	52
3.8	Command source	56
3.9	Digital inputs	58
3.10	Digital outputs	65
3.11	Analog inputs	67
3.12	Analog outputs	74
3.13	Parameter / command / drive data set	77
3.14	BICO command parameters	83
3.15	Communication parameters	86
3.16	Setpoint source	91
3.17	Fixed frequencies	94
3.18	Motorized potentiometer (MOP)	100
3.19	Setpoint channel	102
3.20	Ramp-function generator	107

3.21	Flying restart.....	112
3.22	Automatic restart	114
3.23	Motor holding brake.....	116
3.24	DC braking	118
3.25	Compound braking	121
3.26	V/f control	122
3.27	Bypass.....	124
3.28	Control mode.....	126
3.28.1	Slip compensation	133
3.28.2	Resonance damping	134
3.28.3	I _{max} controller.....	135
3.28.4	Soft starting	137
3.29	Inverter parameters (Modulator)	137
3.30	Motor data identification	138
3.31	Reference parameters.....	139
3.32	Communication parameters (USS, CB)	142
3.33	Faults, Alarms, Monitoring.....	153
3.34	Load torque monitoring	165
3.35	Technology controller (PID controller).....	169
3.36	Staging	183
3.37	Energy saving mode.....	189
3.38	Free function blocks (FFB).....	190
3.39	Inverter parameters	206
4	Function Diagrams	207
5	Faults and Alarms	239
5.1	Fault messages	239
5.2	Alarm Messages.....	245
6	Abbreviations.....	251

1 Block Diagram and Terminals

1.1 Block Diagram

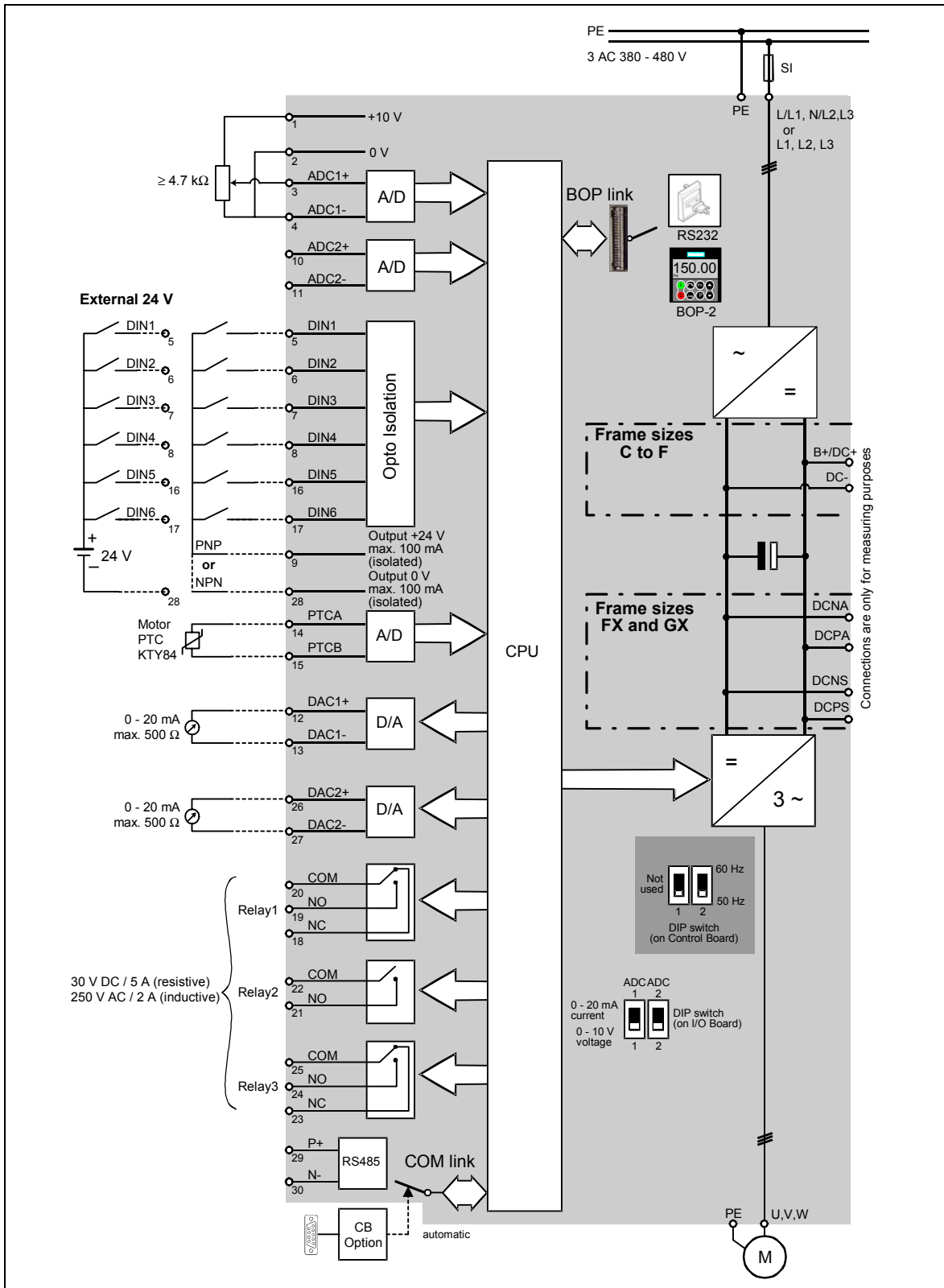

1.2 Power Terminals

You can gain access to the mains and motor terminals by removing the front covers.

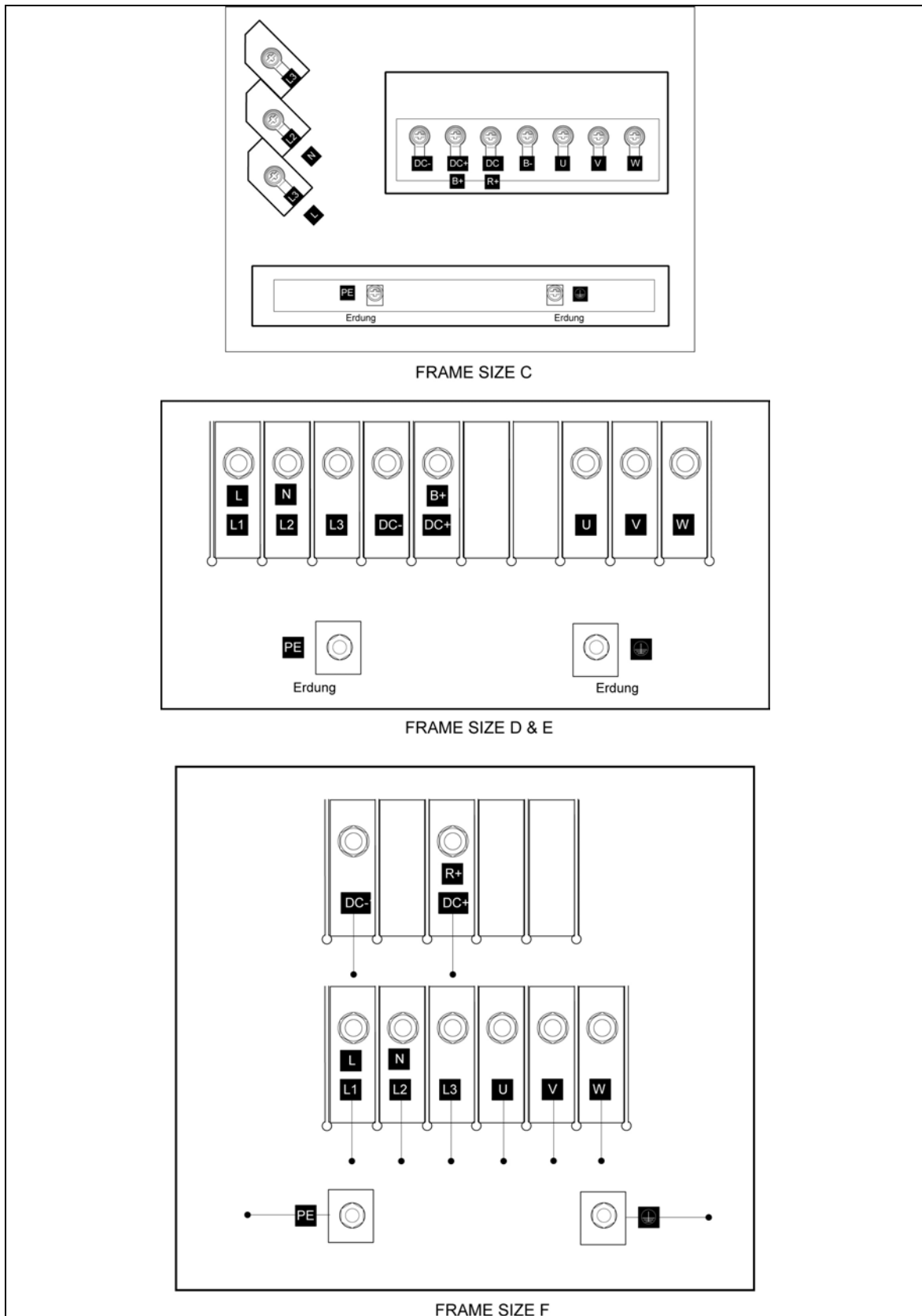

Fig. 1-1 Frame Size C - F

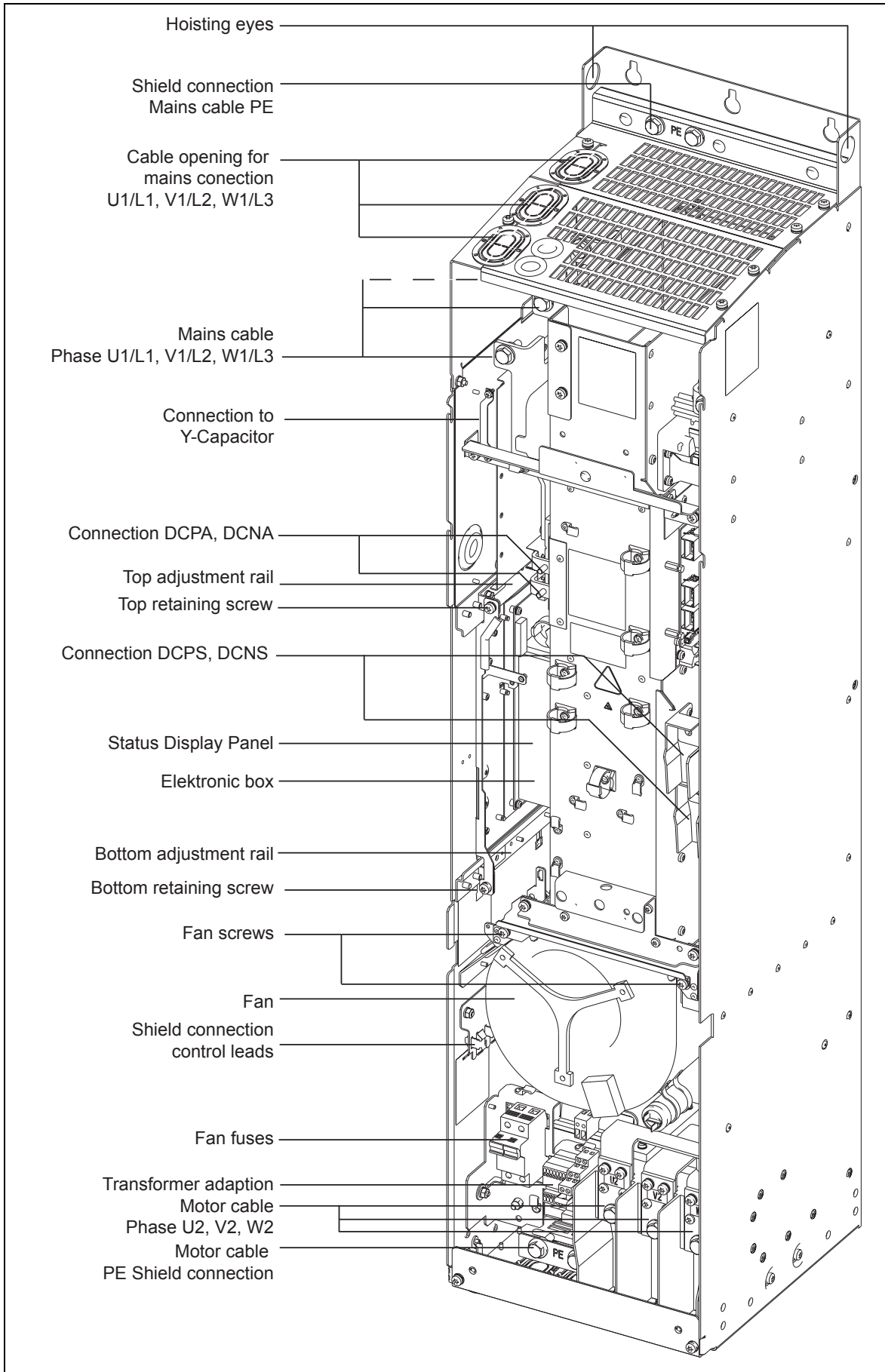

Fig. 1-2 Frame Size FX

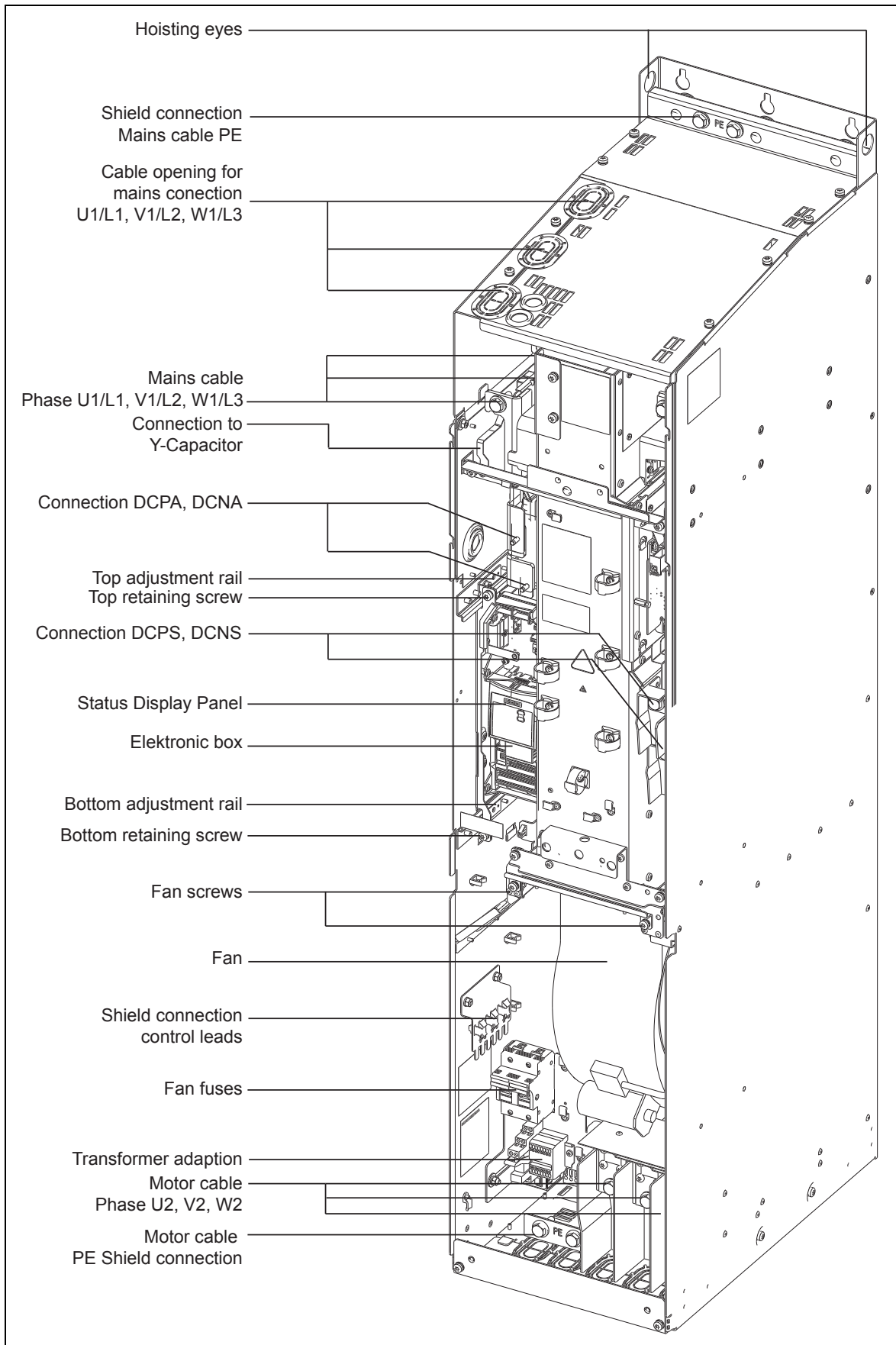

Fig. 1-3 Frame Size GX

1.3 Control Terminals

Terminal	Designation	Function
1	-	Output +10 V
2	-	Output 0 V
3	ADC1+	Analog input 1 (+)
4	ADC1-	Analog input 1 (-)
5	DIN1	Digital input 1
6	DIN2	Digital input 2
7	DIN3	Digital input 3
8	DIN4	Digital input 4
9	-	Isolated output +24 V / max. 100 mA
10	ADC2+	Analog input 2 (+)
11	ADC2-	Analog input 2 (-)
12	DAC1+	Analog output 1 (+)
13	DAC1-	Analog output 1 (-)
14	PTCA	Connection for PTC / KTY84
15	PTCB	Connection for PTC / KTY84
16	DIN5	Digital input 5
17	DIN6	Digital input 6
18	DOUT1/NC	Digital output 1 / NC contact
19	DOUT1/NO	Digital output 1 / NO contact
20	DOUT1/COM	Digital output 1 / Changeover contact
21	DOUT2/NO	Digital output 2 / NO contact
22	DOUT2/COM	Digital output 2 / Changeover contact
23	DOUT3/NC	Digital output 3 / NC contact
24	DOUT3/NO	Digital output 3 / NO contact
25	DOUT3/COM	Digital output 3 / Changeover contact
26	DAC2+	Analog output 2 (+)
27	DAC2-	Analog output 2 (-)
28	-	Isolated output 0 V / max. 100 mA
29	P+	RS485 port
30	N-	RS485 port

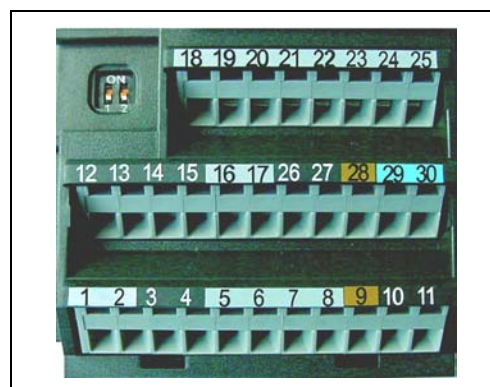

Fig. 1-4 Control terminals of MICROMASTER 430

2 Parameters

2.1 Introduction to MICROMASTER System Parameters

The layout of the parameter description is as follows.

1 Par number [index]	2 Parameter name	5 Datatype	7 Unit:	9 Min:	12 Level:
	3 CStat:	6 active:	8 Quick Comm:	10 Def:	2
	4 P-Group:			11 Max:	
13	Description:				

1. Parameter number

Indicates the relevant parameter number. The numbers used are 4-digit numbers in the range 0000 to 9999. Numbers prefixed with an “r” indicate that the parameter is a “read-only” parameter, which displays a particular value but cannot be changed directly by specifying a different value via this parameter number (in such cases, dashes “-“ are entered at the points “Unit”, “Min”, “Def” and “Max” in the header of the parameter description.

All other parameters are prefixed with a “P”. The values of these parameters can be changed directly in the range indicated by the “Min” and “Max” settings in the header.

[index] indicates that the parameter is an indexed parameter and specifies the number of indices available.

2. Parameter name

Indicates the name of the relevant parameter.

Certain parameter names include the following abbreviated prefixes: BI, BO, CI, and CO followed by a colon.

These abbreviations have the following meanings:

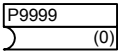
BI =  Binector input, i.e. parameter selects the source of a binary signal

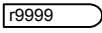
BO =  Binector output, i.e. parameter connects as a binary signal

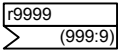
CI =  Connector input, i.e. parameter selects the source of an analog signal

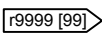
CO =  Connector output, i.e. parameter connects as an analog signal

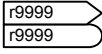
CO/BO =  Connector/Binector output, i.e. parameter connects as an analog signal and/or as a binary signal

To make use of BiCo you will need access to the full parameter list. At this level many new parameter settings are possible, including BiCo functionality. BiCo functionality is a different, more flexible way of setting and combining input and output functions. It can be used in most cases in conjunction with the simple, level 2 settings.

The BiCo system allows complex functions to be programmed. Boolean and mathematical relationships can be set up between inputs (digital, analog, serial etc.) and outputs (inverter current, frequency, analog output, relays, etc.).

3. CStat

Commissioning status of the parameter. Three states are possible:

Commissioning C

Run U

Ready to run T

This indicates when the parameter can be changed. One, two or all three states may be specified. If all three states are specified, this means that it is possible to change this parameter setting in all three inverter states

4. P-Group

Indicates the functional group of the particular.

Note

Parameter P0004 (parameter filter) acts as a filter and focuses access to parameters according to the functional group selected.

5. Datatype

The data types available are shown in the table below.

Notation	Meaning
U16	16-bit unsigned
U32	32-bit unsigned
I16	16-bit integer
I32	32-bit integer
Float	Floating point

6. Active

Indicates whether

- ◆ Immediately changes to the parameter values take effective immediately after they have been entered, or
- ◆ Confirm the "P" button on the operator panel (BOP-2) must be pressed before the changes take effect.

7. Unit

Indicates the unit of measure applicable to the parameter values

8. QuickComm

Indicates whether or not (Yes or No) a parameter can only be changed during quick commissioning, i.e. when P0010 (parameter groups for commissioning) is set to 1 (quick commissioning).

9. Min

Indicates the minimum value to which the parameter can be set.

10. Def

Indicates the default value, i.e. the value which applies if the user does not specify a particular value for the parameter.

11. Max

Indicates the maximum value to which the parameter can be set.

12. Level

Indicates the level of user access. There are four access levels: Standard, Extended, Expert and Service. The number of parameters that appear in each functional group depends on the access level set in P0003 (user access level).

13. Description

The parameter description consists of the sections and contents listed below. Some of these sections and contents are optional and will be omitted on a case-to-case basis if not applicable.

- Description:** Brief explanation of the parameter function.
- Diagram:** Where applicable, diagram to illustrate the effects of parameters on a characteristic curve, for example
- Settings:** List of applicable settings. These include Possible settings, Most common settings, Index and Bitfields
- Example:** Optional example of the effects of a particular parameter setting.
- Dependency:** Any conditions that must be satisfied in connection with this parameter. Also any particular effects, which this parameter has on other parameter(s) or which other parameters have on this one.
- Warning / Caution / Notice / Note:**
Important information which must be heeded to prevent personal injury or damage to equipment / specific information which should be heeded in order to avoid problems / information which may be helpful to the user
- More details:** Any sources of more detailed information concerning the particular parameter.

Operators

The following operators are used in the parameter list to represent mathematical interrelationships:

Arithmetic operators

- + Addition
- Subtraction
- * Multiplication
- / Division

Comparison operators

- > Greater than
- >= Greater than / equal to
- < Less than
- <= Less than / equal to

Equivalence operators

- == Equal to
- != Not equal to

Logical operators

- && AND logic operation
- || OR logic operation

2.2 Quick commissioning (P0010 = 1)

The following parameters are necessary for quick commissioning (P0010 = 1).

Quick commissioning (P0010 = 1)

Par.-No.	Name	Access level	Cstat
P0100	Europe / North America	1	C
P0205	Inverter application	3	C
P0300	Select motor type	2	C
P0304	Motor voltage rating	1	C
P0305	Motor current rating	1	C
P0307	Motor power rating	1	C
P0308	Motor cosPhi rating	2	C
P0309	Motor efficiency rating	2	C
P0310	Motor frequency rating	1	C
P0311	Motor speed rating	1	C
P0320	Motor magnetizing current	3	CT
P0335	Motor cooling	2	CT
P0640	Motor overload factor [%]	2	CUT
P0700	Selection of command source	1	CT
P1000	Selection of frequency setpoint	1	CT
P1080	Min. speed	1	CUT
P1082	Max. speed	1	CT
P1120	Ramp-up time	1	CUT
P1121	Ramp-down time	1	CUT
P1135	OFF3 ramp-down time	2	CUT
P1300	Control mode	2	CT
P1500	Selection of torque setpoint	2	CT
P1910	Select motor data identification	2	CT
P3900	End of quick commissioning	1	C

When P0010 = 1 is chosen, P0003 (user access level) can be used to select the parameters to be accessed. This parameter also allows selection of a user-defined parameter list for quick commissioning.

At the end of the quick commissioning sequence, set P3900 = 1 to carry out the necessary motor calculations and clear all other parameters (not included in P0010 = 1) to their default settings.

Note

This applies only in Quick Commissioning mode.

Reset to Factory default

To reset all parameters to the factory default settings; the following parameters should be set as follows:

Set P0010 = 30

Set P0970 = 1

Note

The reset process takes approximately 10 seconds to complete.

Seven-segment display

The seven-segment display is structured as follows:

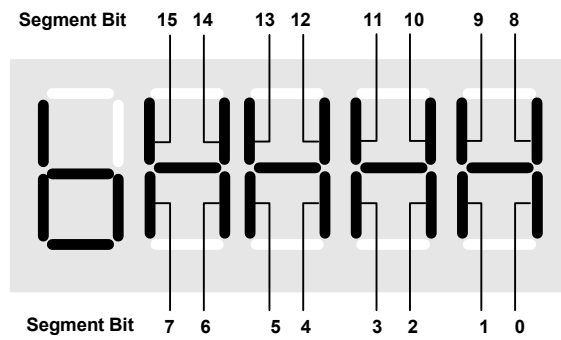

The significance of the relevant bits in the display is described in the status and control word parameters.

2.3 Command and Drive Datasets - Overview

Command Datasets (CDS)

ParNo	Parameter text
P0700[3]	Selection of command source
P0701[3]	Function of digital input 1
P0702[3]	Function of digital input 2
P0703[3]	Function of digital input 3
P0704[3]	Function of digital input 4
P0705[3]	Function of digital input 5
P0706[3]	Function of digital input 6
P0707[3]	Function of digital input 7
P0708[3]	Function of digital input 8
P0719[3]	Selection of cmd. & freq. setp.
P0731[3]	BI: Function of digital output 1
P0732[3]	BI: Function of digital output 2
P0733[3]	BI: Function of digital output 3
P0800[3]	BI: Download parameter set 0
P0801[3]	BI: Download parameter set 1
P0840[3]	BI: ON/OFF1
P0842[3]	BI: ON reverse/OFF1
P0844[3]	BI: 1. OFF2
P0845[3]	BI: 2. OFF2
P0848[3]	BI: 1. OFF3
P0849[3]	BI: 2. OFF3
P0852[3]	BI: Pulse enable
P1000[3]	Selection of frequency setpoint
P1020[3]	BI: Fixed freq. selection Bit 0
P1021[3]	BI: Fixed freq. selection Bit 1
P1022[3]	BI: Fixed freq. selection Bit 2
P1023[3]	BI: Fixed freq. selection Bit 3
P1026[3]	BI: Fixed freq. selection Bit 4
P1028[3]	BI: Fixed freq. selection Bit 5
P1035[3]	BI: Enable MOP (UP-command)
P1036[3]	BI: Enable MOP (DOWN-command)
P1055[3]	BI: Enable JOG right
P1056[3]	BI: Enable JOG left
P1070[3]	CI: Main setpoint
P1071[3]	CI: Main setpoint scaling

ParNo	Parameter text
P1074[3]	BI: Disable additional setpoint
P1075[3]	CI: Additional setpoint
P1076[3]	CI: Additional setpoint scaling
P1110[3]	BI: Inhibit neg. freq. setpoint
P1113[3]	BI: Reverse
P1124[3]	BI: Enable JOG ramp times
P1140[3]	BI: RFG enable
P1141[3]	BI: RFG start
P1142[3]	BI: RFG enable setpoint
P1230[3]	BI: Enable DC braking
P1266[3]	BI: Bypass command
P1270[3]	BI: Enable essential service
P1330[3]	CI: Voltage setpoint
P1477[3]	BI: Set integrator of n-ctrl.
P1478[3]	CI: Set integrator value n-ctrl.
P1500[3]	Selection of torque setpoint
P1501[3]	BI: Change to torque control
P1503[3]	CI: Torque setpoint
P1511[3]	CI: Additional torque setpoint
P1522[3]	CI: Upper torque limit
P1523[3]	CI: Lower torque limit
P2103[3]	BI: 1. Faults acknowledgement
P2104[3]	BI: 2. Faults acknowledgement
P2106[3]	BI: External fault
P2151[3]	CI: Monitoring freq. setpoint
P2152[3]	CI: Act. monitoring frequency
P2200[3]	BI: Enable PID controller
P2220[3]	BI: Fixed PID setp. select Bit 0
P2221[3]	BI: Fixed PID setp. select Bit 1
P2222[3]	BI: Fixed PID setp. select Bit 2
P2223[3]	BI: Fixed PID setp. select Bit 3
P2226[3]	BI: Fixed PID setp. select Bit 4
P2228[3]	BI: Fixed PID setp. select Bit 5
P2235[3]	BI: Enable PID-MOP (UP-cmd)
P2236[3]	BI: Enable PID-MOP (DOWN-cmd)
P2253[3]	CI: PID setpoint
P2254[3]	CI: PID trim source
P2264[3]	CI: PID feedback

Drive Datasets (DDS)

ParNo	Parameter text
P0005[3]	Display selection
r0035[3]	CO: Act. motor temperature
P0291[3]	Inverter protection
P0300[3]	Select motor type
P0304[3]	Rated motor voltage
P0305[3]	Rated motor current
P0307[3]	Rated motor power
P0308[3]	Rated motor cosPhi
P0309[3]	Rated motor efficiency
P0310[3]	Rated motor frequency
P0311[3]	Rated motor speed
r0313[3]	Motor pole pairs
P0314[3]	Motor pole pair number
P0320[3]	Motor magnetizing current
r0330[3]	Rated motor slip
r0331[3]	Rated magnetization current
r0332[3]	Rated power factor
r0333[3]	Rated motor torque
P0335[3]	Motor cooling
P0340[3]	Calculation of motor parameters
P0341[3]	Motor inertia [kg*m ²]
P0342[3]	Total/motor inertia ratio
P0344[3]	Motor weight
r0345[3]	Motor start-up time
P0346[3]	Magnetization time
P0347[3]	Demagnetization time
P0350[3]	Stator resistance (line-to-line)
P0352[3]	Cable resistance
P0354[3]	Rotor resistance
P0356[3]	Stator leakage inductance
P0358[3]	Rotor leakage inductance
P0360[3]	Main inductance
P0362[3]	Magnetizing curve flux 1
P0363[3]	Magnetizing curve flux 2
P0364[3]	Magnetizing curve flux 3
P0365[3]	Magnetizing curve flux 4
P0366[3]	Magnetizing curve imag 1
P0367[3]	Magnetizing curve imag 2
P0368[3]	Magnetizing curve imag 3
P0369[3]	Magnetizing curve imag 4

ParNo	Parameter text
r0370[3]	Stator resistance [%]
r0372[3]	Cable resistance [%]
r0373[3]	Rated stator resistance [%]
r0374[3]	Rotor resistance [%]
r0376[3]	Rated rotor resistance [%]
r0377[3]	Total leakage reactance [%]
r0382[3]	Main reactance [%]
r0384[3]	Rotor time constant
r0386[3]	Total leakage time constant
P0400[3]	Select encoder type
P0408[3]	Encoder pulses per revolution
P0491[3]	Reaction on freq. signal loss
P0492[3]	Allowed frequency difference
P0494[3]	Delay frequency loss reaction
P0500[3]	Technological application
P0601[3]	Motor temperature sensor
P0604[3]	Threshold motor temperature
P0625[3]	Ambient motor temperature
P0626[3]	Overtemperature stator iron
P0627[3]	Overtemperature stator winding
P0628[3]	Overtemperature rotor winding
r0630[3]	CO: Ambient temperature
r0631[3]	CO: Stator iron temperature
r0632[3]	CO: Stator winding temperature
r0633[3]	CO: Rotor winding temperature
P0640[3]	Motor overload factor [%]
P1001[3]	Fixed frequency 1
P1002[3]	Fixed frequency 2
P1003[3]	Fixed frequency 3
P1004[3]	Fixed frequency 4
P1005[3]	Fixed frequency 5
P1006[3]	Fixed frequency 6
P1007[3]	Fixed frequency 7
P1008[3]	Fixed frequency 8
P1009[3]	Fixed frequency 9
P1010[3]	Fixed frequency 10
P1011[3]	Fixed frequency 11
P1012[3]	Fixed frequency 12
P1013[3]	Fixed frequency 13
P1014[3]	Fixed frequency 14

ParNo	Parameter text
P1015[3]	Fixed frequency 15
P1031[3]	Setpoint memory of the MOP
P1040[3]	Setpoint of the MOP
P1058[3]	JOG frequency right
P1059[3]	JOG frequency left
P1060[3]	JOG ramp-up time
P1061[3]	JOG ramp-down time
P1080[3]	Min. frequency
P1082[3]	Max. frequency
P1091[3]	Skip frequency 1
P1092[3]	Skip frequency 2
P1093[3]	Skip frequency 3
P1094[3]	Skip frequency 4
P1101[3]	Skip frequency bandwidth
P1120[3]	Ramp-up time
P1121[3]	Ramp-down time
P1130[3]	Ramp-up initial rounding time
P1131[3]	Ramp-up final rounding time
P1132[3]	Ramp-down initial rounding time
P1133[3]	Ramp-down final rounding time
P1134[3]	Rounding type
P1135[3]	OFF3 ramp-down time
P1202[3]	Motor-current: Flying start
P1203[3]	Search rate: Flying start
P1232[3]	DC braking current
P1233[3]	Duration of DC braking
P1234[3]	DC braking start frequency
P1236[3]	Compound braking current
P1240[3]	Configuration of Vdc controller
P1243[3]	Dynamic factor of Vdc-max
P1250[3]	Gain of Vdc-controller
P1251[3]	Integration time Vdc-controller
P1252[3]	Differential time Vdc-controller
P1253[3]	Vdc-controller output limitation
P1260[3]	Bypass control
P1262[3]	Bypass dead time
P1263[3]	De-Bypass time
P1264[3]	Bypass time
P1265[3]	Bypass frequency
P1300[3]	Control mode

ParNo	Parameter text
P1310[3]	Continuous boost
P1311[3]	Acceleration boost
P1312[3]	Starting boost
P1316[3]	Boost end frequency
P1320[3]	Programmable V/f freq. coord. 1
P1321[3]	Programmable V/f volt. coord. 1
P1322[3]	Programmable V/f freq. coord. 2
P1323[3]	Programmable V/f volt. coord. 2
P1324[3]	Programmable V/f freq. coord. 3
P1325[3]	Programmable V/f volt. coord. 3
P1333[3]	Start frequency for FCC
P1335[3]	Slip compensation
P1336[3]	Slip limit
P1338[3]	Resonance damping gain V/f
P1340[3]	Imax freq. controller prop. gain
P1341[3]	Imax freq. ctrl. integral time
P1345[3]	Imax voltage ctrl. prop. gain
P1346[3]	Imax voltage ctrl. integral time
P1350[3]	Voltage soft start
P1400[3]	Configuration of speed control
P1442[3]	Filter time for act. speed
P1452[3]	Filter time for act. freq. (SLVC)
P1460[3]	Gain speed controller
P1462[3]	Integral time speed controller
P1470[3]	Gain speed controller (SLVC)
P1472[3]	Integral time n-ctrl. (SLVC)
P1488[3]	Droop input source
P1489[3]	Droop scaling
P1492[3]	Enable droop
P1496[3]	Scaling accel. precontrol
P1499[3]	Scaling accel. torque control
P1520[3]	CO: Upper torque limit
P1521[3]	CO: Lower torque limit
P1525[3]	Scaling lower torque limit
P1530[3]	Motoring power limitation
P1531[3]	Regenerative power limitation
P1654[3]	Smooth time for Isq setpoint
P1715[3]	Gain current controller
P1717[3]	Integral time current controller
P1803[3]	Max. modulation

ParNo	Parameter text
P1820[3]	Reverse output phase sequence
P2000[3]	Reference frequency
P2001[3]	Reference voltage
P2002[3]	Reference current
P2003[3]	Reference torque
r2004[3]	Reference power
P2150[3]	Hysteresis frequency f_hys
P2153[3]	Time-constant frequency filter
P2155[3]	Threshold frequency f_1
P2156[3]	Delay time of threshold freq f_1
P2157[3]	Threshold frequency f_2
P2158[3]	Delay time of threshold freq f_2
P2159[3]	Threshold frequency f_3
P2160[3]	Delay time of threshold freq f_3
P2161[3]	Min. threshold for freq. setp.
P2162[3]	Hysteresis freq. for overfreq.
P2163[3]	Entry freq. for perm. deviation
P2164[3]	Hysteresis frequency deviation
P2165[3]	Delay time permitted deviation
P2166[3]	Delay time ramp up completed
P2167[3]	Switch-off frequency f_off
P2168[3]	Delay time T_off
P2170[3]	Threshold current I_thresh
P2171[3]	Delay time current
P2172[3]	Threshold DC-link voltage
P2173[3]	Delay time DC-link voltage
P2174[3]	Torque threshold M_thresh
P2176[3]	Delay time for torque threshold
P2177[3]	Delay time for motor is blocked
P2178[3]	Delay time for motor pulled out
P2181[3]	Belt failure detection mode
P2182[3]	Belt threshold frequency 1
P2183[3]	Belt threshold frequency 2
P2184[3]	Belt threshold frequency 3
P2185[3]	Upper torque threshold 1

ParNo	Parameter text
P2186[3]	Lower torque threshold 1
P2187[3]	Upper torque threshold 2
P2188[3]	Lower torque threshold 2
P2189[3]	Upper torque threshold 3
P2190[3]	Lower torque threshold 3
P2192[3]	Time delay for belt failure
P2201[3]	Fixed PID setpoint 1
P2202[3]	Fixed PID setpoint 2
P2203[3]	Fixed PID setpoint 3
P2204[3]	Fixed PID setpoint 4
P2205[3]	Fixed PID setpoint 5
P2206[3]	Fixed PID setpoint 6
P2207[3]	Fixed PID setpoint 7
P2208[3]	Fixed PID setpoint 8
P2209[3]	Fixed PID setpoint 9
P2210[3]	Fixed PID setpoint 10
P2211[3]	Fixed PID setpoint 11
P2212[3]	Fixed PID setpoint 12
P2213[3]	Fixed PID setpoint 13
P2214[3]	Fixed PID setpoint 14
P2215[3]	Fixed PID setpoint 15
P2231[3]	Setpoint memory of PID-MOP
P2240[3]	Setpoint of PID-MOP
P2370[3]	Motor staging stop mode
P2371[3]	Motor staging configuration
P2372[3]	Motor staging cycling
P2373[3]	Motor staging hysteresis
P2374[3]	Motor staging delay
P2375[3]	Motor destaging delay
P2376[3]	Motor staging delay override
P2377[3]	Motor staging lockout timer
P2378[3]	Motor staging frequency f_st [%]

2.4 Binector Input Parameters

ParNo	Parameter text
P0731[3]	BI: Function of digital output 1
P0732[3]	BI: Function of digital output 2
P0733[3]	BI: Function of digital output 3
P0800[3]	BI: Download parameter set 0
P0801[3]	BI: Download parameter set 1
P0810	BI: CDS bit 0 (Local / Remote)
P0811	BI: CDS bit 1
P0820	BI: DDS bit 0
P0821	BI: DDS bit 1
P0840[3]	BI: ON/OFF1
P0842[3]	BI: ON reverse/OFF1
P0844[3]	BI: 1. OFF2
P0845[3]	BI: 2. OFF2
P0848[3]	BI: 1. OFF3
P0849[3]	BI: 2. OFF3
P0852[3]	BI: Pulse enable
P1020[3]	BI: Fixed freq. selection Bit 0
P1021[3]	BI: Fixed freq. selection Bit 1
P1022[3]	BI: Fixed freq. selection Bit 2
P1023[3]	BI: Fixed freq. selection Bit 3
P1026[3]	BI: Fixed freq. selection Bit 4
P1028[3]	BI: Fixed freq. selection Bit 5
P1035[3]	BI: Enable MOP (UP-command)
P1036[3]	BI: Enable MOP (DOWN-command)
P1074[3]	BI: Disable additional setpoint
P1110[3]	BI: Inhibit neg. freq. setpoint
P1113[3]	BI: Reverse
P1140[3]	BI: RFG enable
P1141[3]	BI: RFG start
P1142[3]	BI: RFG enable setpoint

ParNo	Parameter text
P1230[3]	BI: Enable DC braking
P1266[3]	BI: Bypass command
P2103[3]	BI: 1. Faults acknowledgement
P2104[3]	BI: 2. Faults acknowledgement
P2106[3]	BI: External fault
P2200[3]	BI: Enable PID controller
P2220[3]	BI: Fixed PID setp. select Bit 0
P2221[3]	BI: Fixed PID setp. select Bit 1
P2222[3]	BI: Fixed PID setp. select Bit 2
P2223[3]	BI: Fixed PID setp. select Bit 3
P2226[3]	BI: Fixed PID setp. select Bit 4
P2228[3]	BI: Fixed PID setp. select Bit 5
P2235[3]	BI: Enable PID-MOP (UP-cmd)
P2236[3]	BI: Enable PID-MOP (DOWN-cmd)
P2810[2]	BI: AND 1
P2812[2]	BI: AND 2
P2814[2]	BI: AND 3
P2816[2]	BI: OR 1
P2818[2]	BI: OR 2
P2820[2]	BI: OR 3
P2822[2]	BI: XOR 1
P2824[2]	BI: XOR 2
P2826[2]	BI: XOR 3
P2828	BI: NOT 1
P2830	BI: NOT 2
P2832	BI: NOT 3
P2834[4]	BI: D-FF 1
P2837[4]	BI: D-FF 2
P2840[2]	BI: RS-FF 1
P2843[2]	BI: RS-FF 2
P2846[2]	BI: RS-FF 3
P2849	BI: Timer 1
P2854	BI: Timer 2
P2859	BI: Timer 3
P2864	BI: Timer 4

2.5 Connector Input Parameters

ParNo	Parameter text
P0095[10]	CI: Display PZD signals
P0771[2]	CI: DAC
P1070[3]	CI: Main setpoint
P1071[3]	CI: Main setpoint scaling
P1075[3]	CI: Additional setpoint
P1076[3]	CI: Additional setpoint scaling
P1330[3]	CI: Voltage setpoint
P2016[8]	CI: PZD to BOP link (USS)
P2019[8]	CI: PZD to COM link (USS)
P2051[8]	CI: PZD to CB

ParNo	Parameter text
P2253[3]	CI: PID setpoint
P2254[3]	CI: PID trim source
P2264[3]	CI: PID feedback
P2869[2]	CI: ADD 1
P2871[2]	CI: ADD 2
P2873[2]	CI: SUB 1
P2875[2]	CI: SUB 2
P2877[2]	CI: MUL 1
P2879[2]	CI: MUL 2
P2881[2]	CI: DIV 1
P2883[2]	CI: DIV 2
P2885[2]	CI: CMP 1
P2887[2]	CI: CMP 2

2.6 Binector Output Parameters

ParNo	Parameter text
r1261	BO: Bypass status word
r2032	BO: CtrlWrd1 from BOP link (USS)
r2033	BO: CtrlWrd2 from BOP link (USS)
r2036	BO: CtrlWrd1 from COM link (USS)
r2037	BO: CtrlWrd2 from COM link (USS)
r2090	BO: Control word 1 from CB
r2091	BO: Control word 2 from CB
r2811	BO: AND 1
r2813	BO: AND 2
r2815	BO: AND 3
r2817	BO: OR 1
r2819	BO: OR 2
r2821	BO: OR 3
r2823	BO: XOR 1
r2825	BO: XOR 2
r2827	BO: XOR 3
r2829	BO: NOT 1
r2831	BO: NOT 2
r2833	BO: NOT 3
r2835	BO: Q D-FF 1

ParNo	Parameter text
r2836	BO: NOT-Q D-FF 1
r2838	BO: Q D-FF 2
r2839	BO: NOT-Q D-FF 2
r2841	BO: Q RS-FF 1
r2842	BO: NOT-Q RS-FF 1
r2844	BO: Q RS-FF 2
r2845	BO: NOT-Q RS-FF 2
r2847	BO: Q RS-FF 3
r2848	BO: NOT-Q RS-FF 3
r2852	BO: Timer 1
r2853	BO: Nout timer 1
r2857	BO: Timer 2
r2858	BO: Nout timer 2
r2862	BO: Timer 3
r2863	BO: Nout timer 3
r2867	BO: Timer 4
r2868	BO: Nout timer 4
r2886	BO: CMP 1
r2888	BO: CMP 2

2.7 Connector Output Parameters

ParNo	Parameter text
r0020	CO: Freq. setpoint before RFG
r0021	CO: Act. filtered frequency
r0024	CO: Act. filtered output freq.
r0025	CO: Act. filtered output voltage
r0026	CO: Act. filtered DC-link volt.
r0027	CO: Act. filtered output current
r0031	CO: Act. filtered torque
r0032	CO: Act. filtered power
r0035[3]	CO: Act. motor temperature
r0037[5]	CO: Inverter temperature [°C]
r0038	CO: Act. power factor
r0039	CO: Energy consumpt. meter [kWh]
r0050	CO: Active command data set
r0051[2]	CO: Active drive data set (DDS)
r0061	CO: Act. encoder frequency
r0063	CO: Act. frequency
r0065	CO: Slip frequency
r0067	CO: Act. output current limit
r0068	CO: Output current
r0071	CO: Max. output voltage
r0080	CO: Act. torque
r0086	CO: Act. active current
r0395	CO: Total stator resistance [%]
r0396	CO: Act. rotor resistance
r0755[2]	CO: Act. ADC after scal. [4000h]
r1024	CO: Act. fixed frequency
r1050	CO: Act. Output freq. of the MOP
r1078	CO: Total frequency setpoint
r1114	CO: Freq. setp. after dir. ctrl.
r1119	CO: Freq. setpoint before RFG

ParNo	Parameter text
r1170	CO: Frequency setpoint after RFG
r1242	CO: Switch-on level of Vdc-max
r1337	CO: V/f slip frequency
r1343	CO: I _{max} controller freq. output
r1344	CO: I _{max} controller volt. output
r1801	CO: Act. pulse frequency
r2015[8]	CO: PZD from BOP link (USS)
r2018[8]	CO: PZD from COM link (USS)
r2050[8]	CO: PZD from CB
r2169	CO: Act. filtered frequency
r2224	CO: Act. fixed PID setpoint
r2250	CO: Output setpoint of PID-MOP
r2260	CO: PID setpoint after PID-RFG
r2262	CO: Filtered PID setp. after RFG
r2266	CO: PID filtered feedback
r2272	CO: PID scaled feedback
r2273	CO: PID error
r2294	CO: Act. PID output
r2870	CO: ADD 1
r2872	CO: ADD 2
r2874	CO: SUB 1
r2876	CO: SUB 2
r2878	CO: MUL 1
r2880	CO: MUL 2
r2882	CO: DIV 1
r2884	CO: DIV 2
P2889	CO: Fixed setpoint 1 in [%]
P2890	CO: Fixed setpoint 2 in [%]

2.8 Connector/Binector Output Parameters

ParNo	Parameter text
r0019	CO/BO: BOP control word
r0052	CO/BO: Act. status word 1
r0053	CO/BO: Act. status word 2
r0054	CO/BO: Act. control word 1
r0055	CO/BO: Act. control word 2
r0056	CO/BO: Status of motor control
r0403	CO/BO: Encoder status word

ParNo	Parameter text
P0718	CO/BO: Hand / Auto
r0722	CO/BO: Binary input values
r0747	CO/BO: State of digital outputs
r2197	CO/BO: Monitoring word 1
r2198	CO/BO: Monitoring word 2
r2379	CO/BO: Motor staging status word

3 Parameter Description

Note

Level 4 Parameters are not visible with BOP-2.

3.1 Common parameters

r0000	Drive display	Datatype: U16	Unit: -	Min: -	Level 1
	P-Group: ALWAYS			Def: -	
				Max: -	

Displays the user selected output as defined in P0005.

Note:

Pressing the "Fn" button for 2 seconds allows the user to view the values of DC link voltage, output frequency, output voltage, output current, and chosen r0000 setting (defined in P0005).

r0002	Drive state	Datatype: U16	Unit: -	Min: -	Level 3
	P-Group: COMMANDS			Def: -	
				Max: -	

Displays actual drive state.

Possible Settings:

- 0 Commissioning mode (P0010 != 0)
- 1 Drive ready
- 2 Drive fault active
- 3 Drive starting (DC-link precharging)
- 4 Drive running
- 5 Stopping (ramping down)

Dependency:

State 3 visible only while precharging DC link, and when externally powered communications board is fitted.

P0003	User access level			Min: 0	Level 1
	CStat: CUT	Datatype: U16	Unit: -	Def: 1	
	P-Group: ALWAYS	Active: first confirm	QuickComm.: No	Max: 4	

Defines user access level to parameter sets. The default setting (standard) is sufficient for most simple applications.

Possible Settings:

- 0 User defined parameter list - see P0013 for details on use
- 1 Standard: Allows access into most frequently used parameters.
- 2 Extended: Allows extended access e.g. to inverter I/O functions.
- 3 Expert: For expert use only.
- 4 Service: Only for use by authorized service personal - password protected.

P0004	Parameter filter			Min: 0	Level 1
	CStat: CUT	Datatype: U16	Unit: -	Def: 0	
	P-Group: ALWAYS	Active: first confirm	QuickComm.: No	Max: 22	

Filters available parameters according to functionality to enable a more focussed approach to commissioning.

Possible Settings:

- 0 All parameters
- 2 Inverter
- 3 Motor
- 4 Speed sensor
- 5 Technol. application / units
- 7 Commands, binary I/O
- 8 ADC and DAC
- 10 Setpoint channel / RFG
- 12 Drive features
- 13 Motor control
- 20 Communication
- 21 Alarms / warnings / monitoring
- 22 Technology controller (e.g. PID)

Example:

P0004 = 22 specifies that only PID parameters will be visible.

Dependency:

The parameters are sub-divided into groups (P-Group) according to their functionality. This increases the transparency and allows a parameter to be quickly searched for. Furthermore, parameter P0004 can be used to control the ability to be visualized for the operator panel.

Value	P-Group	Group	Parameter area
0	ALWAYS	All parameters	
2	INVERTER	Drive inverter parameters	0200 0299
3	MOTOR	Motor parameters	0300 ... 0399 + 0600 0699
4	ENCODER	Speed encoder	0400 0499
5	TECH_APL	Technical applications / units	0500 0599
7	COMMANDS	Control commands, digital I/O	0700 0749 + 0800 ... 0899
8	TERMINAL	Analog inputs/outputs	0750 0799
10	SETPOINT	Setpoint channel and ramp-function gen.	1000 1199
12	FUNC	Drive inverter functions	1200 1299
13	CONTROL	Motor open-loop/closed-loop control	1300 1799
20	COMM	Communications	2000 2099
21	ALARMS	Faults, warnings, monitoring functions	2100 2199
22	TECH	Technological controller (PID controller)	2200 2399

Parameters marked "Quick Comm: Yes" in the parameter header can only be set when P0010 = 1 (Quick Commissioning).

P0005[3]	Display selection	Min: 2	Level 2	
	CStat: CUT	Datatype: U16		Unit: -
	P-Group: FUNC	Active: first confirm		QuickComm.: No
		Def: 21		
		Max: 4000		

Selects display for parameter r0000 (drive display).

Index:

- P0005[0] : 1st. Drive data set (DDS)
- P0005[1] : 2nd. Drive data set (DDS)
- P0005[2] : 3rd. Drive data set (DDS)

Common Settings:

- 21 Actual frequency
- 25 Output voltage
- 26 DC link voltage
- 27 Output current

Notice:

These settings refer to read only parameter numbers ("rxxxx").

Details:

See relevant "rxxxx" parameter descriptions.

P0006	Display mode	Min: 0	Level 3	
	CStat: CUT	Datatype: U16		Unit: -
	P-Group: FUNC	Active: first confirm		QuickComm.: No
		Def: 2		
		Max: 4		

Defines mode of display for r0000 (drive display).

Possible Settings:

- 0 In Ready state alternate between setpoint and output frequency. In run display output frequency
- 1 In Ready state display setpoint. In run display output frequency.
- 2 In Ready state alternate between P0005 value and r0020 value. In run display P0005 value
- 3 In Ready state alternate between r0002 value and r0020 value. In run display r0002 value
- 4 In all states just display P0005

Note:

- When inverter is not running, the display alternates between the values for "Not Running" and "Running".
- Per default, the setpoint and actual frequency values are displayed alternately.

P0007	Backlight delay time	Min: 0	Level 3	
	CStat: CUT	Datatype: U16		Unit: -
	P-Group: FUNC	Active: first confirm		QuickComm.: No
		Def: 0		
		Max: 2000		

Defines time period after which the backlight display turns off if no operator keys have been pressed.

Value:

- P0007 = 0:
Backlight always on (default state).
- P0007 = 1 - 2000:
Number of seconds after which the backlight will turn off.

P0010	Commissioning parameter				Min: 0	Level 1
	CStat: CT	Datatype: U16	Unit: -	Def: 0		
	P-Group: ALWAYS	Active: first confirm	QuickComm.: No	Max: 30		

Filters parameters so that only those related to a particular functional group are selected.

Possible Settings:

- 0 Ready
- 1 Quick commissioning
- 2 Inverter
- 29 Download
- 30 Factory setting

Dependency:

- Reset to 0 for inverter to run.
- P0003 (user access level) also determines access to parameters.

Note:

P0010 = 1
The inverter can be commissioned very quickly and easily by setting P0010 = 1. After that only the important parameters (e.g.: P0304, P0305, etc.) are visible. The value of these parameters must be entered one after the other. The end of quick commissioning and the start of internal calculation will be done by setting P3900 = 1 - 3. Afterward parameter P0010 and P3900 will be reset to zero automatically.

P0010 = 2
For service purposes only.

P0010 = 29
To transfer a parameter file via PC tool (e.g.: DriveMonitor, STARTER) parameter P0010 will be set to 29 by the PC tool. When download has been finished PC tool resets parameter P0010 to zero.

P0010 = 30
When resetting the parameters of inverter P0010 must be set to 30. Resetting of the parameters will be started by setting parameter P0970 = 1. The inverter will automatically reset all its parameters to their default settings. This can prove beneficial if you experience problems during parameter setup and wish to start again. Duration of factory setting will take about 60 s.

P0011	Lock for user defined parameter				Min: 0	Level 3
	CStat: CUT	Datatype: U16	Unit: -	Def: 0		
	P-Group: FUNC	Active: first confirm	QuickComm.: No	Max: 65535		

Details:

See parameter P0013 (user defined parameter)

P0012	Key for user defined parameter				Min: 0	Level 3
	CStat: CUT	Datatype: U16	Unit: -	Def: 0		
	P-Group: FUNC	Active: first confirm	QuickComm.: No	Max: 65535		

Details:

See parameter P0013 (user defined parameter).

P0013[20]	User defined parameter				Min: 0	Level 3
	CStat: CUT	Datatype: U16	Unit: -	Def: 0		
	P-Group: FUNC	Active: first confirm	QuickComm.: No	Max: 65535		

Defines a limited set of parameters to which the end user will have access.

Instructions for use:

1. Set P0003 = 3 (expert user)
2. Go to P0013 indices 0 to 16 (user list)
3. Enter into P0013 index 0 to 16 the parameters required to be visible in the user-defined list. The following values are fixed and cannot be changed:
 - P0013 index 19 = 12 (key for user defined parameter)
 - P0013 index 18 = 10 (commissioning parameter filter)
 - P0013 index 17 = 3 (user access level)
4. Set P0003 = 0 to activate the user defined parameter.

Index:

- P0013[0] : 1st user parameter
- P0013[1] : 2nd user parameter
- P0013[2] : 3rd user parameter
- P0013[3] : 4th user parameter
- P0013[4] : 5th user parameter
- P0013[5] : 6th user parameter
- P0013[6] : 7th user parameter
- P0013[7] : 8th user parameter
- P0013[8] : 9th user parameter
- P0013[9] : 10th user parameter
- P0013[10] : 11th user parameter
- P0013[11] : 12th user parameter
- P0013[12] : 13th user parameter
- P0013[13] : 14th user parameter
- P0013[14] : 15th user parameter
- P0013[15] : 16th user parameter
- P0013[16] : 17th user parameter
- P0013[17] : 18th user parameter
- P0013[18] : 19th user parameter
- P0013[19] : 20th user parameter

Dependency:

First, set P0011 ("lock") to a different value than P0012 ("key") to prevent changes to user-defined parameter. Then, set P0003 to 0 to activate the user-defined list.

When locked and the user-defined parameter is activated, the only way to exit the user-defined parameter (and view other parameters) is to set P0012 ("key") to the value in P0011 ("lock").

Note:

- Alternatively, set P0010 = 30 (commissioning parameter filter = factory setting) and P0970 = 1 (factory reset) to perform a complete factory reset.
- The default values of P0011 ("lock") and P0012 ("key") are the same.

3.2 Diagnosis parameters

r0018	Firmware version	Datatype: Float	Unit: -	Min: - Def: - Max: -	Level 3
	P-Group: INVERTER				

Displays version number of installed firmware.

r0019	CO/BO: BOP control word	Datatype: U16	Unit: -	Min: - Def: - Max: -	Level 3
	P-Group: COMMANDS				

Displays status of operator panel commands.

The settings below are used as the "source" codes for keypad control when connecting to BICO input parameters.

Bitfields:

Bit00	ON/OFF1	0	NO	1	YES
Bit01	OFF2: Electrical stop	0	YES	1	NO
Bit08	JOG right	0	NO	1	YES
Bit11	Reverse (setpoint inversion)	0	NO	1	YES
Bit12	Hand Operation	0	NO	1	YES
Bit13	Motor potentiometer MOP up	0	NO	1	YES
Bit14	Motor potentiometer MOP down	0	NO	1	YES
Bit15	Auto Operation	0	NO	1	YES

Note:

When BICO technology is used to allocate functions to panel buttons, this parameter displays the actual status of the relevant command.

The following functions can be "connected" to individual buttons:

- ON/OFF1,
- OFF2,
- JOG,
- REVERSE,
- INCREASE,
- DECREASE

r0020	CO: Freq. setpoint before RFG	Datatype: Float	Unit: Hz	Min: - Def: - Max: -	Level 3
	P-Group: CONTROL				

Displays actual frequency setpoint (input from ramp function generator).

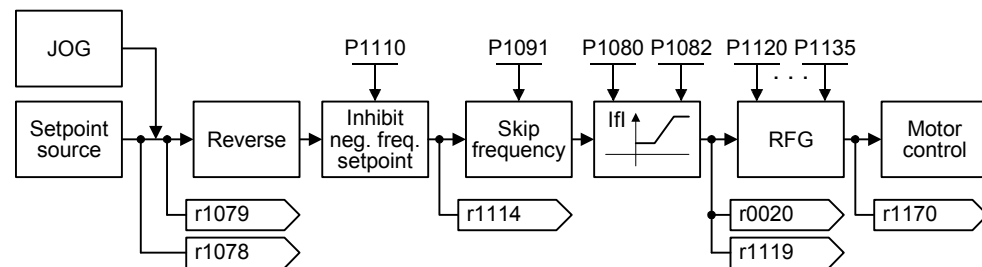

r0021	CO: Act. filtered frequency	Datatype: Float	Unit: Hz	Min: - Def: - Max: -	Level 3
	P-Group: CONTROL				

Displays actual inverter output frequency (r0021) excluding slip compensation, resonance damping and frequency limitation.

r0022	Act. filtered rotor speed	Datatype: Float	Unit: 1/min	Min: - Def: - Max: -	Level 3
	P-Group: CONTROL				

Displays calculated rotor speed based on inverter output frequency [Hz] x 120 / number of poles.

$$r0022 [1/min] = r0021 [Hz] \cdot \frac{60}{r0313}$$

Note:

This calculation makes no allowance for load-dependent slip.

r0024	CO: Act. filtered output freq.	Datatype: Float	Unit: Hz	Min: - Def: - Max: -	Level 3
	P-Group: CONTROL				

Displays actual output frequency (slip compensation, resonance damping and frequency limitation are included).

r0025	CO: Act. filtered output voltage	Datatype: Float	Unit: V	Min: - Def: - Max: -	Level 3
	P-Group: CONTROL				

Displays [rms] voltage applied to motor.

r0026	CO: Act. filtered DC-link volt.	Datatype: Float	Unit: V	Min: - Def: - Max: -	Level 3
	P-Group: INVERTER				

Displays DC-link voltage.

		Mains 380 - 480 V
U _{DC_max_trip}	F0002	820 V
U _{DC_min_trip}	F0003	430 V
U _{DC_max_warn}	A0502	r1242
U _{DC_max_ctrl}	(P1240)	r1242
U _{DC_Comp}	(P1236)	0.98 · r1242

r0027	CO: Act. filtered output current	Datatype: Float	Unit: A	Min: - Def: - Max: -	Level 3
	P-Group: CONTROL				

Displays [rms] value of motor current [A].

r0031	CO: Act. filtered torque	Datatype: Float	Unit: Nm	Min: - Def: - Max: -	Level 3
	P-Group: CONTROL				

Displays electrical torque.

$$m_M = \frac{3}{2} \cdot \frac{L_m}{L_R} \cdot Z_p \cdot \Psi_{rd} \cdot i_{sq}$$

- m_M : Motor torque
- Z_p : Pole pair number
- Ψ_{rd} : Rotor flux
- L_R : Rotor inductance
- L_m : Magnetizing inductance
- i_{sq} : Torque-generating current
- e : Motor counter EMF

Valid for V/f-characteristic:

$$i_{sq} \approx \frac{u \cdot |i_s| \cdot \cos \varphi - R_s^2 \cdot |i_s|}{e}$$

Output value will be zero at low speeds when the current injection is active (r1751.5 = 1).

Note:

The electrical torque is not the same as the mechanical torque, which can be measured on the shaft. Due to windage and friction a part of the electrical torque is lost in the motor.

r0032	CO: Act. filtered power	Datatype: Float	Unit: -	Min: - Def: - Max: -	Level 3
	P-Group: CONTROL				

Displays motor power (power output at the motor shaft).

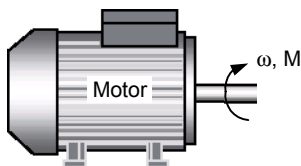

$$P_{mech} = \omega \cdot M = 2 \cdot \pi \cdot f \cdot M$$

$$\Rightarrow r0032 [kW] = \frac{1}{1000} \cdot 2 \cdot \pi \cdot \frac{r0022}{60} [1/min] \cdot r0031 [Nm]$$

$$r0032 [hp] = 0.75 \cdot r0032 [kW]$$

Dependency:

Value is displayed in [kW] or [hp] depending on setting for P0100 (operation for Europe / North America).

r0035[3]	CO: Act. motor temperature	Datatype: Float	Unit: °C	Min: -	Level 3
	P-Group: MOTOR			Def: - Max: -	

Displays measured motor temperature.

Index:

- r0035[0] : 1st. Drive data set (DDS)
- r0035[1] : 2nd. Drive data set (DDS)
- r0035[2] : 3rd. Drive data set (DDS)

r0037[5]	CO: Inverter temperature [°C]	Datatype: Float	Unit: °C	Min: -	Level 3
	P-Group: INVERTER			Def: - Max: -	

Displays measured heatsink temperature and calculated junction temperature of IGBTs based on thermal model.

Index:

- r0037[0] : Measured heat sink temperature
- r0037[1] : Chip temperature
- r0037[2] : Rectifier temperature
- r0037[3] : Inverter ambient temperature
- r0037[4] : Control board temperature

r0038	CO: Act. power factor	Datatype: Float	Unit: -	Min: -	Level 3
	P-Group: CONTROL			Def: - Max: -	

Displays actual power factor.

Dependency:

Applies when V/f control is selected in P1300 (control mode); otherwise, the display shows the value 1.

r0039	CO: Energy consumpt. meter [kWh]	Datatype: Float	Unit: kWh	Min: -	Level 3
	P-Group: INVERTER			Def: - Max: -	

Displays electrical energy used by inverter since display was last reset (see P0040 - reset energy consumption meter).

$$r0039 = \int_0^{t_{act}} P_W \cdot dt = \int_0^{t_{act}} \sqrt{3} \cdot u \cdot i \cdot \cos \varphi \cdot dt$$

Dependency:

Value is reset when P0040 = 1 (reset energy consumption meter).

P0040	Reset energy consumption meter			Min: 0	Level 3
	CStat: CT	Datatype: U16	Unit: -	Def: 0	
	P-Group: INVERTER	Active: first confirm	QuickComm.: No	Max: 1	

Resets value of parameter r0039 (energy consumption meter) to zero.

Possible Settings:

- 0 No reset
- 1 Reset r0039 to 0

Dependency:

No reset until "P" is pressed.

r0050	CO: Active command data set	Datatype: U16	Unit: -	Min: -	Level 2
	P-Group: COMMANDS			Def: - Max: -	

Displays currently selected and active command data set (CDS).

Possible Settings:

- 0 1st. Command data set (CDS)
- 1 2nd. Command data set (CDS)
- 2 3rd. Command data set (CDS)

Details:

See parameter P0810.

r0051[2]	CO: Active drive data set (DDS)	Datatype: U16	Unit: -	Min: -	Def: -	Max: -	Level
	P-Group: COMMANDS						2

Displays currently selected and active drive data set (DDS).

Possible Settings:

- 0 1st. Drive data set (DDS)
- 1 2nd. Drive data set (DDS)
- 2 3rd. Drive data set (DDS)

Index:

- r0051[0] : Selected drive data set
- r0051[1] : Active drive data set

Details:

See parameter P0820.

r0052	CO/BO: Act. status word 1	Datatype: U16	Unit: -	Min: -	Def: -	Max: -	Level
	P-Group: COMMANDS						3

Displays first active status word of inverter (bit format) and can be used to diagnose inverter status.

Bitfields:

Bit00	Drive ready	0 NO	1 YES
Bit01	Drive ready to run	0 NO	1 YES
Bit02	Drive running	0 NO	1 YES
Bit03	Drive fault active	0 NO	1 YES
Bit04	OFF2 active	0 YES	1 NO
Bit05	OFF3 active	0 YES	1 NO
Bit06	ON inhibit active	0 NO	1 YES
Bit07	Drive warning active	0 NO	1 YES
Bit08	Deviation setpoint / act. value	0 YES	1 NO
Bit09	PZD control	0 NO	1 YES
Bit10	Maximum frequency reached	0 NO	1 YES
Bit11	Warning: Motor current limit	0 YES	1 NO
Bit12	Motor holding brake active	0 NO	1 YES
Bit13	Motor overload	0 YES	1 NO
Bit14	Motor runs right	0 NO	1 YES
Bit15	Inverter overload	0 YES	1 NO

Dependency:

r0052 Bit00 - Bit02:

State-sequence diagram after Power On or ON/OFF1 respectively: ==> see below

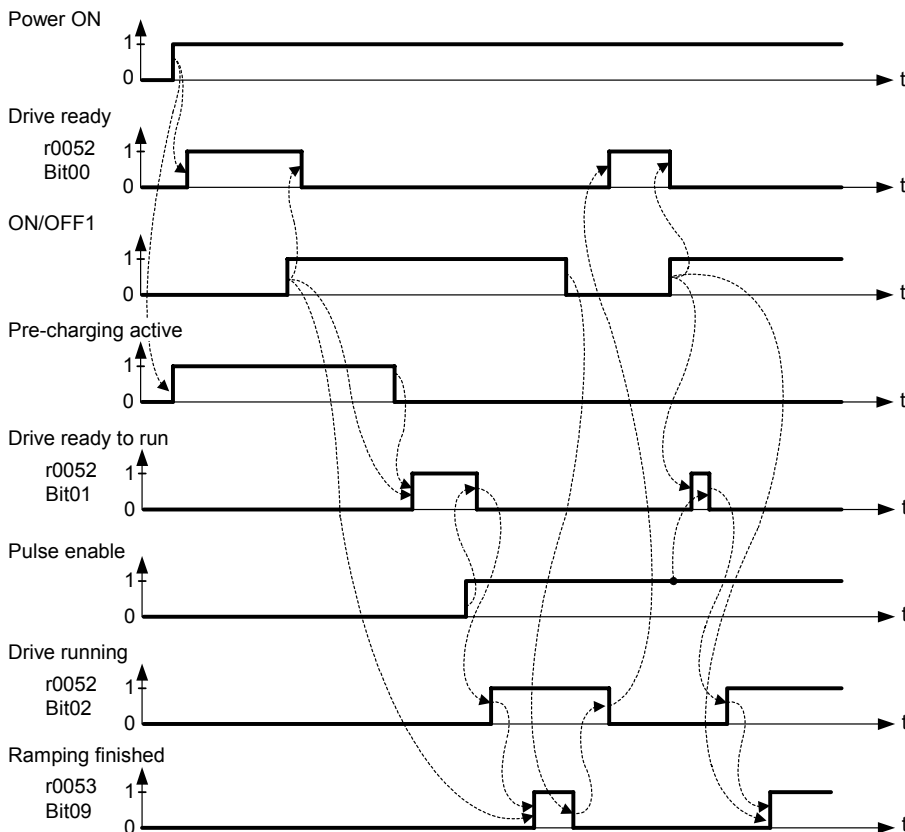

r0052 Bit03 "Drive fault active":
Output of Bit3 (Fault) will be inverted on digital output (Low = Fault, High = No Fault).

r0052 Bit08 "Deviation setpoint / act. value" ==> see parameter P2164

r0052 Bit10 "f_act >= P1082 (f_max)" ==> see parameter P1082

r0052 Bit12 "Motor holding brake active" ==> see parameter P1215

r0052 Bit14 "Motor runs right" ==> see below

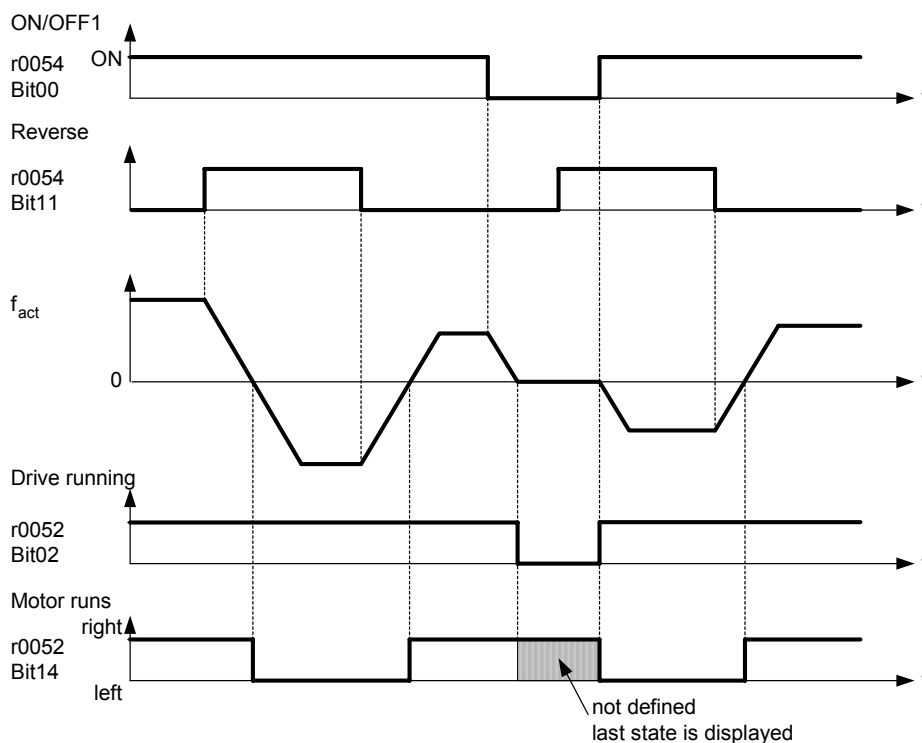

Details:

The 7-segment display of the bit-parameters (binary parameters) is explained in the Introduction of the Parameter List.

r0053	CO/BO: Act. status word 2	Datatype: U16	Unit: -	Min: -	Def: -	Max: -	Level
	P-Group: COMMANDS						3

Displays second status word of inverter (in bit format).

Bitfields:

Bit00	DC brake active	0	NO	1	YES
Bit01	f_act > P2167 (f_off)	0	NO	1	YES
Bit02	f_act <= P1080 (f_min)	0	NO	1	YES
Bit03	Act. current r0027 > P2170	0	NO	1	YES
Bit04	f_act > P2155 (f_1)	0	NO	1	YES
Bit05	f_act <= P2155 (f_1)	0	NO	1	YES
Bit06	f_act >= setpoint	0	NO	1	YES
Bit07	Act. Vdc r0026 < P2172	0	NO	1	YES
Bit08	Act. Vdc r0026 > P2172	0	NO	1	YES
Bit09	Ramping finished	0	NO	1	YES
Bit10	PID output r2294 == P2292 (PID_min)	0	NO	1	YES
Bit11	PID output r2294 == P2291 (PID_max)	0	NO	1	YES
Bit14	Download data set 0 from AOP	0	NO	1	YES
Bit15	Download data set 1 from AOP	0	NO	1	YES

Note:

- r0053 Bit00 ==> see parameter P1233
- r0053 Bit01 ==> see parameter P2167
- r0053 Bit02 ==> see parameter P1080
- r0053 Bit03 ==> see parameter P2170
- r0053 Bit04 ==> see parameter P2155
- r0053 Bit05 ==> see parameter P2155
- r0053 Bit06 ==> see parameter P2150
- r0053 Bit07 ==> see parameter P2172
- r0053 Bit08 ==> see parameter P2172

r0053 Bit09 "Ramping finished" ==> see below

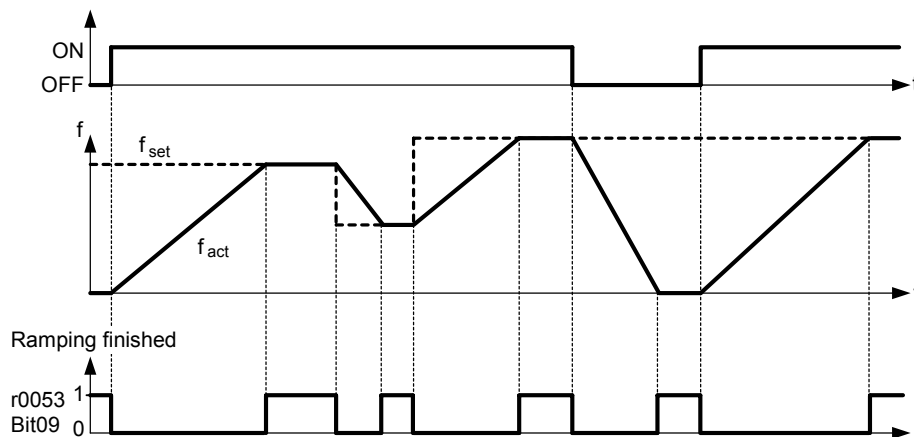

Details:

See description of seven-segment display given in the "Introduction to MICROMASTER System Parameters" in this manual.

r0054	CO/BO: Act. control word 1	Datatype: U16	Unit: -	Min: - Def: - Max: -	Level 3
	P-Group: COMMANDS				

Displays first control word of inverter and can be used to diagnose which commands are active.

Bitfields:

Bit00	ON/OFF1	0	NO	1	YES
Bit01	OFF2: Electrical stop	0	YES	1	NO
Bit02	OFF3: Fast stop	0	YES	1	NO
Bit03	Pulse enable	0	NO	1	YES
Bit04	RFG enable	0	NO	1	YES
Bit05	RFG start	0	NO	1	YES
Bit06	Setpoint enable	0	NO	1	YES
Bit07	Fault acknowledge	0	NO	1	YES
Bit08	JOG right	0	NO	1	YES
Bit09	JOG left	0	NO	1	YES
Bit10	Control from PLC	0	NO	1	YES
Bit11	Reverse (setpoint inversion)	0	NO	1	YES
Bit13	Motor potentiometer MOP up	0	NO	1	YES
Bit14	Motor potentiometer MOP down	0	NO	1	YES
Bit15	CDS Bit 0 (Local/Remote)	0	NO	1	YES

Details:

See description of seven-segment display given in the "Introduction to MICROMASTER System Parameters" in this manual.

r0055	CO/BO: Act. control word 2	Datatype: U16	Unit: -	Min: - Def: - Max: -	Level 3
	P-Group: COMMANDS				

Displays additional control word of inverter and can be used to diagnose which commands are active.

Bitfields:

Bit00	Fixed frequency Bit 0	0	NO	1	YES
Bit01	Fixed frequency Bit 1	0	NO	1	YES
Bit02	Fixed frequency Bit 2	0	NO	1	YES
Bit03	Fixed frequency Bit 3	0	NO	1	YES
Bit04	Drive data set (DDS) Bit 0	0	NO	1	YES
Bit05	Drive data set (DDS) Bit 1	0	NO	1	YES
Bit08	PID enabled	0	NO	1	YES
Bit09	DC brake enabled	0	NO	1	YES
Bit11	Droop enabled	0	NO	1	YES
Bit12	Torque control	0	NO	1	YES
Bit13	External fault 1	0	YES	1	NO
Bit15	Command data set (CDS) Bit 1	0	NO	1	YES

Details:

See description of seven-segment display given in the "Introduction to MICROMASTER System Parameters" in this handbook.

r0056	CO/BO: Status of motor control	Datatype: U16	Unit: -	Min: - Def: - Max: -	Level 3
	P-Group: CONTROL				

Displays status of motor control (MM420: V/f status), which can be used to diagnose inverter status.

Bitfields:

Bit00	Init. control finished	0	NO	1	YES
Bit01	Motor demagnetizing finished	0	NO	1	YES
Bit02	Pulses enabled	0	NO	1	YES
Bit03	Voltage soft start selected	0	NO	1	YES
Bit04	Motor excitation finished	0	NO	1	YES
Bit05	Starting boost active	0	NO	1	YES
Bit06	Acceleration boost active	0	NO	1	YES
Bit07	Frequency is negative	0	NO	1	YES
Bit08	Field weakening active	0	NO	1	YES
Bit09	Volts setpoint limited	0	NO	1	YES
Bit10	Slip frequency limited	0	NO	1	YES
Bit11	F _{out} > F _{max} Freq. limited	0	NO	1	YES
Bit12	Phase reversal selected	0	NO	1	YES
Bit13	I-max controller active	0	NO	1	YES
Bit14	Vdc-max controller active	0	NO	1	YES
Bit15	KIB (Vdc-min control) active	0	NO	1	YES

Details:

See description of seven-segment display given in the introduction.

r0061	CO: Act. encoder frequency	Datatype: Float	Unit: Hz	Min: - Def: - Max: -	Level 3
	P-Group: CONTROL				

Displays actual frequency detected by encoder.

r0063	CO: Act. frequency	Datatype: Float	Unit: Hz	Min: - Def: - Max: -	Level 3
	P-Group: CONTROL				

Displays actual unfiltered frequency.

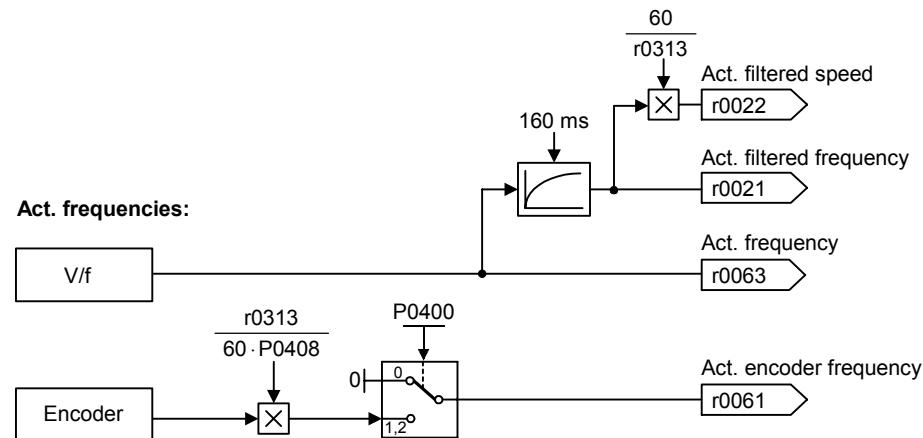

r0065	CO: Slip frequency	Datatype: Float	Unit: %	Min: - Def: - Max: -	Level 3
	P-Group: CONTROL				

Displays slip frequency of motor in [%] relative to the rated motor frequency (P0310).

Details:

For V/f control, see also P1335 (slip compensation).

r0067	CO: Act. output current limit	Datatype: Float	Unit: A	Min: - Def: - Max: -	Level 3
	P-Group: CONTROL				

Displays valid maximum output current of inverter.

Parameter r0067 is influenced/determined by the following factors:

- Rated motor current P0305
- Motor overload factor P0640
- Motor protection in dependency of P0610
- r0067 is less than or equal to maximum inverter current r0209
- Inverter protection in dependency of P0290

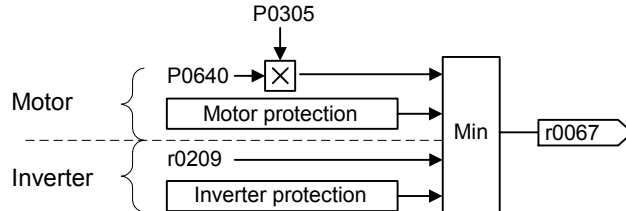

Note:

A reduction of r0067 may indicate an inverter overload or a motor overload.

r0068	CO: Output current	Datatype: Float	Unit: A	Min: - Def: - Max: -	Level 3
	P-Group: CONTROL				

Displays unfiltered [rms] value of motor current [A].

Note:

Used for process control purposes (in contrast to filtered output current r0027, which is used for display).

r0071	CO: Max. output voltage	Datatype: Float	Unit: V	Min: - Def: - Max: -	Level 3
	P-Group: CONTROL				

Displays maximum output voltage.

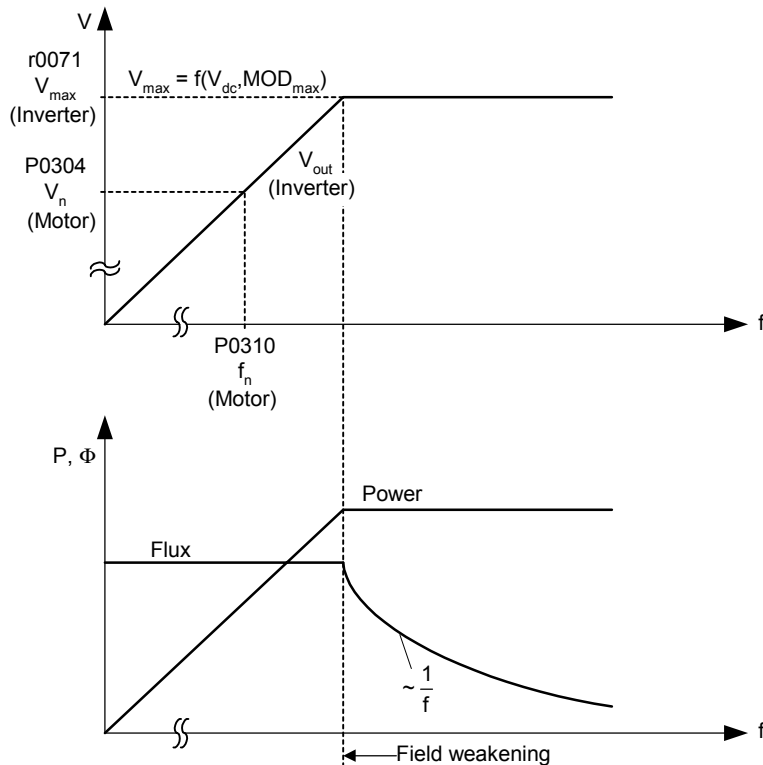

Dependency:

- The actual maximum output voltage depends on the actual incoming line supply voltage.
- The maximum possible output voltage r0071 of the drive inverter is determined by the DC link voltage r0026 and the maximum modulation depth P1803 in the gating unit.
- The maximum output voltage r0071 is tracked with the DC link voltage so that the highest possible value is always and automatically achieved.
- The output voltage only reaches the calculated maximum value under steady-state conditions at the rated load.
- In the no-load and partial load ranges, lower output voltages r0025 are obtained.

r0080	CO: Act. torque	Datatype: Float	Unit: Nm	Min: - Def: - Max: -	Level 3
	P-Group: CONTROL				

Displays actual torque. Output value will be zero at low frequencies when current injection is active (r1751.5 = 1).

r0086	CO: Act. active current	Datatype: Float	Unit: A	Min: - Def: - Max: -	Level 3
	P-Group: CONTROL				

Displays active (real part) of motor current.

Dependency:

Applies when V/f control is selected in P1300 (control mode); otherwise, the display shows the value zero.

P0095[10]	CI: Display PZD signals	Datatype: U32	Unit: -	Min: 0:0 Def: 0:0 Max: 4000:0	Level 3
	CStat: CT P-Group: CONTROL	Active: first confirm	QuickComm.: No		

Selects source of display for PZD signals.

Index:

- P0095[0] : 1st PZD signal
- P0095[1] : 2nd PZD signal
- P0095[2] : 3rd PZD signal
- P0095[3] : 4th PZD signal
- P0095[4] : 5th PZD signal
- P0095[5] : 6th PZD signal
- P0095[6] : 7th PZD signal
- P0095[7] : 8th PZD signal
- P0095[8] : 9th PZD signal
- P0095[9] : 10th PZD signal

r0096[10]	PZD signals	Datatype: Float	Unit: %	Min: - Def: - Max: -	Level 3
	P-Group: CONTROL				

Displays PZD signals in [%].

Index:

- r0096[0] : 1st PZD signal
- r0096[1] : 2nd PZD signal
- r0096[2] : 3rd PZD signal
- r0096[3] : 4th PZD signal
- r0096[4] : 5th PZD signal
- r0096[5] : 6th PZD signal
- r0096[6] : 7th PZD signal
- r0096[7] : 8th PZD signal
- r0096[8] : 9th PZD signal
- r0096[9] : 10th PZD signal

Note:

r0096 = 100 % corresponds to 4000 hex.

3.3 Inverter parameters (HW)

P0100	Europe / North America	Min: 0	Level 1	
	CStat: C	Datatype: U16		Unit: -
	P-Group: QUICK	Active: first confirm		QuickComm.: Yes
		Def: 0		
		Max: 2		

Determines whether power settings (e.g. nominal rating plate power - P0307) are expressed in [kW] or [hp].

The default settings for the nominal rating plate frequency (P0310) and maximum motor frequency (P1082) are also set automatically here, in addition to reference frequency (P2000).

Possible Settings:

- 0 Europe [kW], frequency default 50 Hz
- 1 North America [hp], frequency default 60 Hz
- 2 North America [kW], frequency default 60 Hz

Dependency:

Where:

- Stop drive first (i.e. disable all pulses) before you change this parameter.
- Changing P0100 resets all rated motor parameters as well as other parameters that depend on the rated motor parameters (see P0340 - calculation of motor parameters).

Changing P0100 overwrites the settings of the DIP50/60 switch (location shown in the diagram below):

1. Parameter P0100 has a higher priority than the DIP50/60 switch.
2. However, after the inverter is powered-on again and P0100 < 2, the DIP50/60 setting will take priority and overwrite P0100.
3. The DIP50/60 switch does not have any effect, if P0100 = 2.

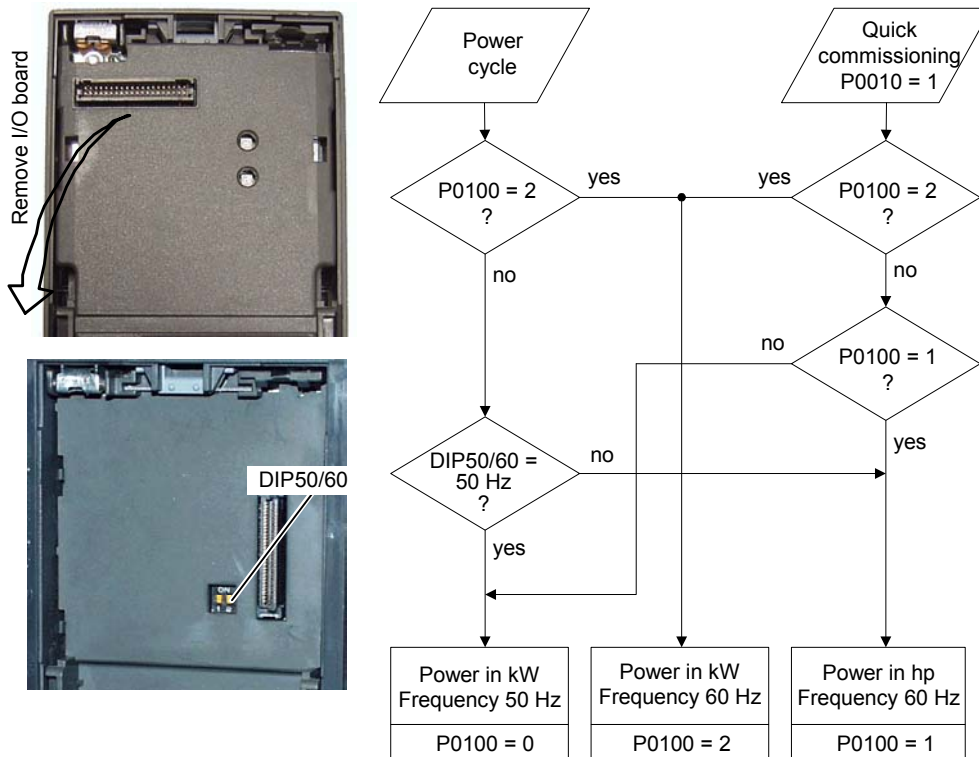

Notice:

P0100 setting 2 (==> [kW], frequency default 60 [Hz]) is not overwritten by the setting of DIP switch 2 (see diagram above).

P0199	Equipment system number	Min: 0	Level 2	
	CStat: UT	Datatype: U16		Unit: -
	P-Group: -	Active: first confirm		QuickComm.: No
		Def: 0		
		Max: 255		

Equipment system number. This parameter has no operation effect.

r0200	Act. power stack code number	Min: -	Level 3
	Datatype: U32 Unit: -	Def: -	
	P-Group: INVERTER	Max: -	

Identifies hardware variant as shown in table below.

Code- No.	MM430 MLFB	Input Voltage & Frequency	VT Power kW	Internal Filter	Protection Degree	Frame Size
271	6SE6430-2UD27-5CA0	3AC380-480V +10% -10% 47-63Hz	7.5	no	IP20	C
272	6SE6430-2UD31-1CA0	3AC380-480V +10% -10% 47-63Hz	11	no	IP20	C
273	6SE6430-2UD31-5CA0	3AC380-480V +10% -10% 47-63Hz	15	no	IP20	C
274	6SE6430-2AD27-5CA0	3AC380-480V +10% -10% 47-63Hz	7.5	Cl. A	IP20	C
275	6SE6430-2AD31-1CA0	3AC380-480V +10% -10% 47-63Hz	11	Cl. A	IP20	C
276	6SE6430-2AD31-5CA0	3AC380-480V +10% -10% 47-63Hz	15	Cl. A	IP20	C
277	6SE6430-2UD31-8DA0	3AC380-480V +10% -10% 47-63Hz	18.5	no	IP20	D
278	6SE6430-2UD32-2DA0	3AC380-480V +10% -10% 47-63Hz	22	no	IP20	D
279	6SE6430-2UD33-0DA0	3AC380-480V +10% -10% 47-63Hz	30	no	IP20	D
280	6SE6430-2AD31-8DA0	3AC380-480V +10% -10% 47-63Hz	18.5	Cl. A	IP20	D
281	6SE6430-2AD32-2DA0	3AC380-480V +10% -10% 47-63Hz	22	Cl. A	IP20	D
282	6SE6430-2AD33-0DA0	3AC380-480V +10% -10% 47-63Hz	30	Cl. A	IP20	D
283	6SE6430-2UD33-7EA0	3AC380-480V +10% -10% 47-63Hz	37	no	IP20	E
284	6SE6430-2UD34-5EA0	3AC380-480V +10% -10% 47-63Hz	45	no	IP20	E
285	6SE6430-2AD33-7EA0	3AC380-480V +10% -10% 47-63Hz	37	Cl. A	IP20	E
286	6SE6430-2AD34-5EA0	3AC380-480V +10% -10% 47-63Hz	45	Cl. A	IP20	E
287	6SE6430-2UD35-5FA0	3AC380-480V +10% -10% 47-63Hz	55	no	IP20	F
288	6SE6430-2UD37-5FA0	3AC380-480V +10% -10% 47-63Hz	75	no	IP20	F
289	6SE6430-2UD38-8FA0	3AC380-480V +10% -10% 47-63Hz	90	no	IP20	F
290	6SE6430-2AD35-5FA0	3AC380-480V +10% -10% 47-63Hz	55	Cl. A	IP20	F
291	6SE6430-2AD37-5FA0	3AC380-480V +10% -10% 47-63Hz	75	Cl. A	IP20	F
292	6SE6430-2AD38-8FA0	3AC380-480V +10% -10% 47-63Hz	90	Cl. A	IP20	F
1201	6SE6430-2UD41-1FA0	3AC380-480V +10% -10% 47-63Hz	110	no	IP20	FX
1202	6SE6430-2UD41-3FA0	3AC380-480V +10% -10% 47-63Hz	132	no	IP20	FX
1203	6SE6430-2UD41-6GA0	3AC380-480V +10% -10% 47-63Hz	160	no	IP20	GX
1204	6SE6430-2UD42-0GA0	3AC380-480V +10% -10% 47-63Hz	200	no	IP20	GX
1205	6SE6430-2UD42-5GA0	3AC380-480V +10% -10% 47-63Hz	250	no	IP20	GX

Notice:

Parameter r0200 = 0 indicates that no power stack has been identified.

P0201	Power stack code number	Min: 0	Level 3
	CStat: C Datatype: U16 Unit: -	Def: 0	
	P-Group: INVERTER Active: first confirm QuickComm.: No	Max: 65535	

Confirms actual power stack identified.

r0203	Act. inverter type	Min: -	Level 3
	Datatype: U16 Unit: -	Def: -	
	P-Group: INVERTER	Max: -	

Type number of actual inverter identified.

Possible Settings:

- 1 MICROMASTER 420
- 2 MICROMASTER 440
- 3 MICRO- / COMBIMASTER 411
- 4 MICROMASTER 410
- 5 Reserved
- 6 MICROMASTER 440 PX
- 7 MICROMASTER 430
- 8 MICROMASTER 430 PX

r0204	Power stack features	Datatype: U32	Unit: -	Min: - Def: - Max: -	Level 3
	P-Group: INVERTER				
	Displays hardware features of power stack.				
	Bitfields:				
	Bit00	DC input voltage	0 NO	1 YES	
	Bit01	RFI filter	0 NO	1 YES	
	Note:	Parameter r0204 = 0 indicates that no power stack has been identified.			
r0206	Rated inverter power [kW] / [hp]	Datatype: Float	Unit: -	Min: - Def: - Max: -	Level 3
	P-Group: INVERTER				
	Displays nominal rated motor power from inverter.				
	Dependency:	Value is displayed in [kW] or [hp] depending on setting for P0100 (operation for Europe / North America).			
		$r0206 \text{ [hp]} = 0.75 \cdot r0206 \text{ [kW]}$			
r0207	Rated inverter current	Datatype: Float	Unit: A	Min: - Def: - Max: -	Level 3
	P-Group: INVERTER				
	Displays maximum continuous output current of inverter.				
r0208	Rated inverter voltage	Datatype: U32	Unit: V	Min: - Def: - Max: -	Level 3
	P-Group: INVERTER				
	Displays nominal AC supply voltage of inverter.				
	Value:	r0208 = 230 : 200 - 240 V +/- 10 % r0208 = 400 : 380 - 480 V +/- 10 % r0208 = 575 : 500 - 600 V +/- 10 %			
r0209	Maximum inverter current	Datatype: Float	Unit: A	Min: - Def: - Max: -	Level 3
	P-Group: INVERTER				
	Displays maximum output current of inverter.				
	Dependency:	Parameter r0209 depends on the derating which is affected by pulse frequency P1800, ambient temperature and altitude. The data of deration is given in the OPERATING INSRTRUCTION.			
P0210	Supply voltage	Datatype: U16	Unit: V	Min: 0 Def: 230 Max: 1000	Level 3
	CStat: CT P-Group: INVERTER	Active: Immediately	QuickComm.: No		
	Parameter P0210 defines the supply voltage. Its default value depends upon the type of inverter. If P0210 does not correspond to the supply voltage, then it must be modified.				
	When P0210 has been modified, the following thresholds are changed:				
	Dependency:	Optimizes Vdc controller, which extends the ramp-down time if regenerative energy from motor would otherwise cause DC link overvoltage trips.			
		Reducing the value enables controller to cut in earlier and reduce the risk of overvoltage.			
		Set P1254 ("Auto detect Vdc switch-on levels") = 0. Cut-in levels for Vdc-controller and compound braking are then derived directly from P0210 (supply voltage).			
		Vdc_max switch-on level	$= 1.15 \cdot \sqrt{2} \cdot P0210$		
		Compound braking switch-on level	$= 1.13 \cdot \sqrt{2} \cdot P0210$		
	Note:	<ul style="list-style-type: none"> - If mains voltage is higher than value entered, automatic deactivation of the Vdc controller may occur to avoid acceleration of the motor. An alarm will be issued in this case (A0910). - Default value is depending on inverter type and its rating data. 			

r0231[2]	Max. cable length	Datatype: U16	Unit: m	Min: -	Level 3
	P-Group: INVERTER			Def: - Max: -	

Indexed parameter to display maximum allowable cable length between inverter and motor.

Index:

- r0231[0] : Max. allowed unscreened cable length
- r0231[1] : Max. allowed screened cable length

Notice:

For full EMC compliance, the screened cable must not exceed 25 m in length when an EMC filter is fitted.

P0290	Inverter overload reaction	Datatype: U16	Unit: -	Min: 0	Level 3
	CStat: CT	Active: first confirm	QuickComm.: No	Def: 2	
	P-Group: INVERTER			Max: 3	

Selects reaction of inverter to an internal over-temperature.

Following physical values influence the inverter overload protection (see diagram):

- heat sink temperature
- junction temperature (IGBT temperature)
- inverter I²t

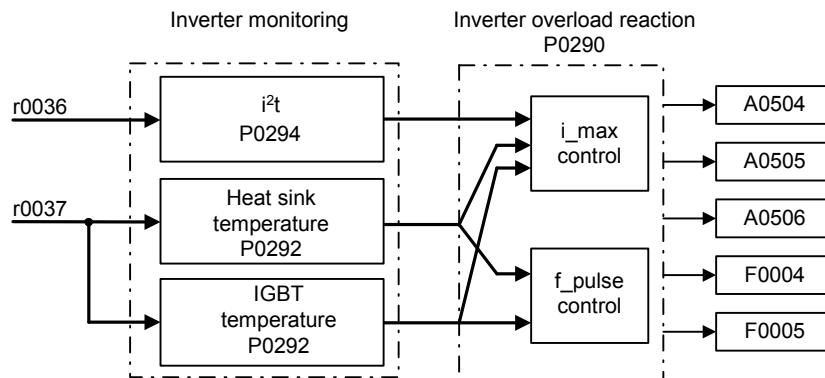

Possible Settings:

- 0 Reduce output frequency
- 1 Trip (F0004)
- 2 Reduce pulse frequency and output frequency
- 3 Reduce pulse frequency then trip (F0004)

Notice:

P0290 = 0:
Reduction of output frequency is only effective if the load is also reduced. This is for example valid for variable torque applications with a quadratic torque characteristic as pumps or fans.

A trip will always result, if the action taken does not sufficiently reduce internal temperature.

The pulse frequency P1800 is reduced only if higher than 2 kHz. The actual pulse frequency is displayed in parameter r1801.

P0291[3]	Inverter protection	Datatype: U16	Unit: -	Min: 0	Level 3
	CStat: CT	Active: Immediately	QuickComm.: No	Def: 1	
	P-Group: INVERTER			Max: 7	

Bit 02 shows if phase loss dedection (input phase) of 3 phase inverters is enabled after factory reset. Default setting of phase loss is disabled for FSA - FSC. FSD and greater it is enabled.

Bitfields:

Bit00	Reserved	0	NO	1	YES
Bit01	Reserved	0	NO	1	YES
Bit02	Phase loss detection enable	0	NO	1	YES

Index:

- P0291[0] : 1st. Drive data set (DDS)
- P0291[1] : 2nd. Drive data set (DDS)
- P0291[2] : 3rd. Drive data set (DDS)

Details:

See P0290 (inverter overload reaction)

P0292	Inverter temperature warning	Min: 0	Level 3
	CStat: CUT Datatype: U16 Unit: °C Def: 15		
	P-Group: INVERTER Active: first confirm QuickComm.: No Max: 25		

Defines the temperature difference (in °C) between the Overtemperature trip threshold and the warning threshold of the inverter. The trip threshold is stored internally by the inverter and cannot be changed by the user.

Temperature warning threshold of inverter T_{warn} :

$$T_{warn} = T_{trip} - P0292$$

Temperature shutdown threshold of inverter T_{trip} :

Temperature	MM430, Frame Size		
	C	D - E	F
Heat sink	110 °C	95 °C	90 °C
IGBT	140 °C	145 °C	145 °C

If the actual inverter temperature (r0037) exceeds the corresponding threshold, a warning A0504, if the temperature still increases then a fault F0004 will be displayed.

P0295	Inverter fan off delay time	Min: 0	Level 3
	CStat: CUT Datatype: U16 Unit: s Def: 0		
	P-Group: TERMINAL Active: first confirm QuickComm.: No Max: 3600		

Defines inverter fan switch off delay time in seconds after drive has stopped.

Note:

Setting to 0, inverter fan will switch off when the drive stops, that is no delay.

3.4 Motor parameters

P0304[3]	Rated motor voltage	Min: 10	Level 1
	CStat: C Datatype: U16 Unit: V Def: 230		
	P-Group: MOTOR Active: first confirm QuickComm.: Yes Max: 2000		

Nominal motor voltage [V] from rating plate. Following diagram shows a typical rating plate with the locations of the relevant motor data.

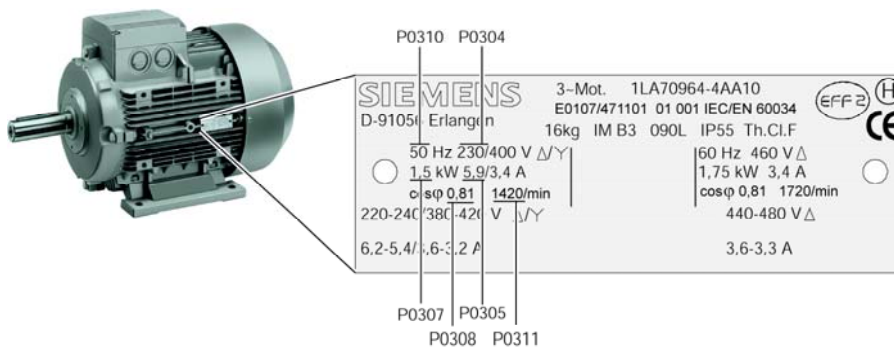

Line supply voltage	1 AC 110 V *)	1 AC 230 V	3 AC 230 V	3 AC 400 V	3 AC 500 V
MICROMASTER 410	X	X	-	-	-
MICROMASTER 411	-	-	-	X	-
MICROMASTER 420	-	X	X	X	-
MICROMASTER 430	-	-	-	X	-
MICROMASTER 440	-	X	X	X	X

*) Line supply voltage 1-ph. 110 V AC is stepped-up --> frequency inverter output voltage 3-ph. 230 V AC

Index:

- P0304[0] : 1st. Drive data set (DDS)
- P0304[1] : 2nd. Drive data set (DDS)
- P0304[2] : 3rd. Drive data set (DDS)

Dependency:

- Changeable only when P0010 = 1 (quick commissioning).
- Default value is depending on inverter type and its rating data.



Caution:

The input of rating plate data must correspond with the wiring of the motor (star / delta). This means, if delta wiring is used for the motor, delta rating plate data has to be entered.

IEC Motor

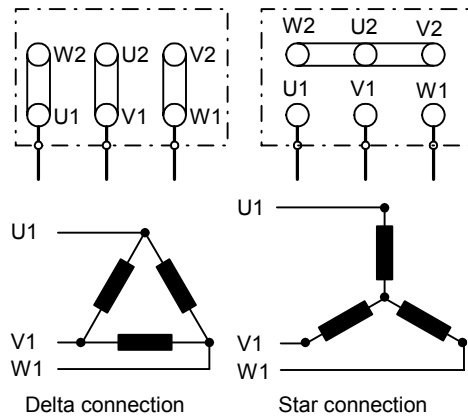

e.g.: Volts 230 V (Delta connection) / 400 V (Star connection)

NEMA Motor

Volts	U	V	W	Connected together	Connection
low	T ₁ -T ₇	T ₂ -T ₈	T ₃ -T ₉	T ₄ -T ₅ -T ₆	YY
high	T ₁	T ₂	T ₃	T ₁ -T ₇ T ₂ -T ₈ T ₃ -T ₉	Y

e.g.: Volts 230 V YY (low) / 460 V Y (high)

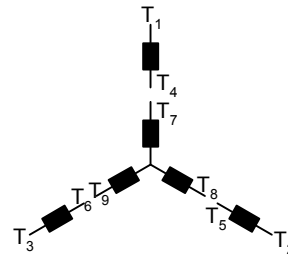

Volts	U	V	W	Connected together	Connection
low	T ₁ -T ₆ -T ₇	T ₂ -T ₄ -T ₈	T ₃ -T ₅ -T ₉	-	Δ Δ
high	T ₁	T ₂	T ₃	T ₄ -T ₇ T ₅ -T ₈ T ₆ -T ₉	Δ

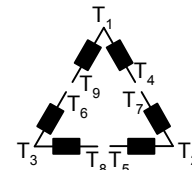

P0305[3]	Rated motor current	Min: 0.01	Level 1	
	CStat: C	Datatype: Float		Unit: A
	P-Group: MOTOR	Active: first confirm		QuickComm.: Yes
		Def: 3.25		
		Max: 10000.00		

Nominal motor current [A] from rating plate - see diagram in P0304.

Index:

- P0305[0] : 1st. Drive data set (DDS)
- P0305[1] : 2nd. Drive data set (DDS)
- P0305[2] : 3rd. Drive data set (DDS)

Dependency:

- Changeable only when P0010 = 1 (quick commissioning).
- Default value is depending on inverter type and its rating data.
- Depends also on P0320 (motor magnetization current).

Note:

The maximum value of P0305 depends on the maximum inverter current r0209 and the motor type:

Asynchronous motor : P0305_{max, asyn} = r0209

Synchronous motor : P0305_{max, syn} = 2 · r0209

It is recommended that the ratio of P0305 (rated motor current) and r0207 (rated inverter current) should not be lower than:

$$V/f: \frac{1}{8} \leq \frac{P0305}{r0207}$$

P0307[3]	Rated motor power	Min: 0.01	Level 1
	CStat: C Datatype: Float Unit: - Def: 0.12 P-Group: MOTOR Active: first confirm QuickComm.: Yes Max: 2000.00		
	Nominal motor power [kW/hp] from rating plate.		
Index:	P0307[0] : 1st. Drive data set (DDS) P0307[1] : 2nd. Drive data set (DDS) P0307[2] : 3rd. Drive data set (DDS)		
Dependency:	<ul style="list-style-type: none"> - If P0100 = 1, values will be in [hp] - see diagram P0304 (rating plate). - Changeable only when P0010 = 1 (quick commissioning). - Default value is depending on inverter type and its rating data. 		
P0308[3]	Rated motor cosPhi	Min: 0.000	Level 3
	CStat: C Datatype: Float Unit: - Def: 0.000 P-Group: MOTOR Active: first confirm QuickComm.: Yes Max: 1.000		
	Nominal motor power factor (cosPhi) from rating plate - see diagram P0304.		
Index:	P0308[0] : 1st. Drive data set (DDS) P0308[1] : 2nd. Drive data set (DDS) P0308[2] : 3rd. Drive data set (DDS)		
Dependency:	<ul style="list-style-type: none"> - Changeable only when P0010 = 1 (quick commissioning). - Visible only when P0100 = 0 or 2, (motor power entered in [kW]). - Default value is depending on inverter type and its rating data. - Setting 0 causes internal calculation of value. Calculated value see r0332. 		
P0309[3]	Rated motor efficiency	Min: 0.0	Level 3
	CStat: C Datatype: Float Unit: % Def: 0.0 P-Group: MOTOR Active: first confirm QuickComm.: Yes Max: 99.9		
	Nominal motor efficiency in [%] from rating plate.		
Index:	P0309[0] : 1st. Drive data set (DDS) P0309[1] : 2nd. Drive data set (DDS) P0309[2] : 3rd. Drive data set (DDS)		
Dependency:	<ul style="list-style-type: none"> - Changeable only when P0010 = 1 (quick commissioning). - Visible only when P0100 = 1, (i.e. motor power entered in [hp]). - Default value is depending on inverter type and its rating data. - Setting 0 causes internal calculation of value. Calculated value see r0332. 		
Note:	P0309 = 100 % corresponds to superconducting.		
Details:	See diagram in P0304 (rating plate).		
P0310[3]	Rated motor frequency	Min: 12.00	Level 1
	CStat: C Datatype: Float Unit: Hz Def: 50.00 P-Group: MOTOR Active: first confirm QuickComm.: Yes Max: 650.00		
	Nominal motor frequency [Hz] from rating plate.		
Index:	P0310[0] : 1st. Drive data set (DDS) P0310[1] : 2nd. Drive data set (DDS) P0310[2] : 3rd. Drive data set (DDS)		
Dependency:	<ul style="list-style-type: none"> - Changeable only when P0010 = 1 (quick commissioning). - Pole pair number recalculated automatically if parameter is changed. 		
Details:	See diagram in P0304 (rating plate)		

P0311[3]	Rated motor speed	Min: 0	Level 1	
	CStat: C	Datatype: U16		Unit: 1/min
	P-Group: MOTOR	Active: first confirm		QuickComm.: Yes
		Def: 0		
		Max: 40000		

Nominal motor speed [rpm] from rating plate.

Index:

- P0311[0] : 1st. Drive data set (DDS)
- P0311[1] : 2nd. Drive data set (DDS)
- P0311[2] : 3rd. Drive data set (DDS)

Dependency:

- Changeable only when P0010 = 1 (quick commissioning).
- Setting 0 causes internal calculation of value.
- Slip compensation in V/f control requires rated motor speed for correct operation.
- Pole pair number recalculated automatically if parameter is changed.
- Default value is depending on inverter type and its rating data.

Details:

See diagram in P0304 (rating plate)

r0313[3]	Motor pole pairs	Min: -	Level 3	
		Datatype: U16		Unit: -
	P-Group: MOTOR			Def: -
		Max: -		

Displays number of motor pole pairs that the inverter is currently using for internal calculations.

Index:

- r0313[0] : 1st. Drive data set (DDS)
- r0313[1] : 2nd. Drive data set (DDS)
- r0313[2] : 3rd. Drive data set (DDS)

Value:

- r0313 = 1 : 2-pole motor
- r0313 = 2 : 4-pole motor
- etc.

Dependency:

Recalculated automatically when P0310 (rated motor frequency) or P0311 (rated motor speed) is changed.

$$r0313 = 60 \cdot \frac{P0310}{P0311}$$

P0320[3]	Motor magnetizing current	Min: 0.0	Level 3	
	CStat: CT	Datatype: Float		Unit: %
	P-Group: MOTOR	Active: Immediately		QuickComm.: Yes
		Def: 0.0		
		Max: 99.0		

Defines motor magnetization current in [%] relative to P0305 (rated motor current).

Index:

- P0320[0] : 1st. Drive data set (DDS)
- P0320[1] : 2nd. Drive data set (DDS)
- P0320[2] : 3rd. Drive data set (DDS)

Dependency:

P0320 = 0:
Setting 0 causes calculation by P0340 = 1 (data entered from rating plate) or by P3900 = 1 - 3 (end of quick commissioning). The calculated value is displayed in parameter r0331.

r0330[3]	Rated motor slip	Min: -	Level 3	
		Datatype: Float		Unit: %
	P-Group: MOTOR			Def: -
		Max: -		

Displays nominal motor slip in [%] relative to P0310 (rated motor frequency) and P0311 (rated motor speed).

$$r0330 [\%] = \frac{P0310 - \frac{P0311}{60} \cdot r0313}{P0310} \cdot 100 \%$$

Index:

- r0330[0] : 1st. Drive data set (DDS)
- r0330[1] : 2nd. Drive data set (DDS)
- r0330[2] : 3rd. Drive data set (DDS)

r0331[3]	Rated magnetization current	Datatype: Float	Unit: A	Min: -	Level 3
	P-Group: MOTOR			Def: - Max: -	

Displays calculated magnetizing current of motor in [A].

Index:

r0331[0] : 1st. Drive data set (DDS)
r0331[1] : 2nd. Drive data set (DDS)
r0331[2] : 3rd. Drive data set (DDS)

r0332[3]	Rated power factor	Datatype: Float	Unit: -	Min: -	Level 3
	P-Group: MOTOR			Def: - Max: -	

Displays power factor for motor

Index:

r0332[0] : 1st. Drive data set (DDS)
r0332[1] : 2nd. Drive data set (DDS)
r0332[2] : 3rd. Drive data set (DDS)

Dependency:

Value is calculated internally if P0308 (rated motor cosPhi) set to 0; otherwise, value entered in P0308 is displayed.

P0335[3]	Motor cooling	Datatype: U16	Unit: -	Min: 0	Level 3
	CStat: CT	Active: first confirm	QuickComm.: Yes	Def: 0	
	P-Group: MOTOR			Max: 3	

Selects motor cooling system used.

Possible Settings:

- 0 Self-cooled: Using shaft mounted fan attached to motor
- 1 Force-cooled: Using separately powered cooling fan
- 2 Self-cooled and internal fan
- 3 Force-cooled and internal fan

Index:

P0335[0] : 1st. Drive data set (DDS)
P0335[1] : 2nd. Drive data set (DDS)
P0335[2] : 3rd. Drive data set (DDS)

Caution:

The following combination of parameter setting should not be combined:

- P0610 = 1 and P0335 = 0 or 2 :
When P0335 = 0 or 2 the inverter cools the motor using a shaft mounted fan. If this is used in conjunction with P0610 the cooling of the motor will be inefficient. In essence, if the i2t calculation reduces the output frequency, then the shaft mounted fan will also reduce its cooling effect, the motor will then eventually overheat and trip.
- Exception:
Applications with variable torque the reduction of max. current leads automatically to a reduction of the load / output current.

Notice:

Motors of series 1LA1 and 1LA8 have an internal fan. This internal motor fan must not be confused with the fan at the end of the motor shaft.

P0340[3]	Calculation of motor parameters				Min: 0	Level 3
	CStat: CT	Datatype: U16	Unit: -	Def: 0		
	P-Group: MOTOR	Active: first confirm	QuickComm.: No	Max: 4		

Calculates various motor parameters (see table below). This parameter is required during commissioning to optimize inverter performance.

Possible Settings:

- 0 No calculation
- 1 Complete parameterization
- 2 Calculation of equivalent circuit data
- 3 Calculation of V/f data
- 4 Calculation of controller settings only

Index:

- P0340[0] : 1st. Drive data set (DDS)
- P0340[1] : 2nd. Drive data set (DDS)
- P0340[2] : 3rd. Drive data set (DDS)

Note:

P0340 = 0:
No calculation

P0340 = 1:
The motor weight/moment of inertia (P0344, P0341) are determined starting from the rating plate parameters (P0300 - P0335), the motor equivalent circuit diagram parameters (ESB, P0350 - P0369). The V/f control parameters and reference quantities are then pre-assigned (includes all of the calculations from P0340 = 2,3,4).

P0340 = 2:
The motor equivalent circuit diagram parameters (ESB, P0350 - P0369) are calculated starting from the rating plate parameters (without any other pre-assignments made).

P0340 = 3:
The V/f control parameters are determined (includes all calculations from P0340 = 4) starting from the motor equivalent circuit diagram parameters (ESB, P0350 - P0369) and motor weight/moment of inertia, moment of inertia ratio (P0344, P0341, P0342).

P0340 = 4:
The control parameters are pre-assigned starting from the motor equivalent circuit diagram parameters (ESB, P0350 - P0369) and motor weight/moment of inertia, moment of inertia ratio (P0344, P0341, P0342).

	P0340 = 1	P0340 = 2	P0340 = 3	P0340 = 4
P0344[3] Motor weight	x			
P0346[3] Magnetization time	x		x	
P0347[3] Demagnetization time	x		x	
P0350[3] Stator resistance (line-to-line)	x	x		
P0352[3] Cable resistance	x	x		
P0625[3] Ambient motor temperature	x	x		
P1253[3] Vdc-controller output limitation	x		x	
P1316[3] Boost end frequency	x		x	
P2000[3] Reference frequency	x			
P2002[3] Reference current	x			
P2003[3] Reference torque	x			
P2174[3] Torque threshold M_thresh	x			
P2185[3] Upper torque threshold 1	x			
P2186[3] Lower torque threshold 1	x			
P2187[3] Upper torque threshold 2	x			
P2188[3] Lower torque threshold 2	x			
P2189[3] Upper torque threshold 3	x			
P2190[3] Lower torque threshold 3	x			

P0344[3]	Motor weight			Min: 1.0	Level 3
	CStat: CUT	Datatype: Float	Unit: kg	Def: 9.4	
	P-Group: MOTOR	Active: Immediately	QuickComm.: No	Max: 6500.0	

Specifies motor weight [kg].

Index:

- P0344[0] : 1st. Drive data set (DDS)
- P0344[1] : 2nd. Drive data set (DDS)
- P0344[2] : 3rd. Drive data set (DDS)

Note:

- This value is used in the motor thermal model.
- It is normally calculated automatically from P0340 (motor parameters) but can also be entered manually.
- Default value is depending on inverter type and its rating data.

P0346[3]	Magnetization time			Min: 0.000	Level 3
	CStat: CUT	Datatype: Float	Unit: s	Def: 1.000	
	P-Group: MOTOR	Active: Immediately	QuickComm.: No	Max: 20.000	

Sets magnetization time [s], i.e. waiting time between pulse enable and start of ramp-up. Motor magnetization builds up during this time.

Magnetization time is normally calculated automatically from the motor data and corresponds to the rotor time constant (r0384).

Index:

- P0346[0] : 1st. Drive data set (DDS)
- P0346[1] : 2nd. Drive data set (DDS)
- P0346[2] : 3rd. Drive data set (DDS)

Note:

- If boost settings are higher than 100 %, magnetization time may be reduced.
- Default value is depending on inverter type and its rating data.
- An excessive reduction of this time can result in insufficient motor magnetization.

P0347[3]	Demagnetization time			Min: 0.000	Level 3
	CStat: CUT	Datatype: Float	Unit: s	Def: 1.000	
	P-Group: MOTOR	Active: Immediately	QuickComm.: No	Max: 20.000	

Defines the de-magnetization time for the connected induction motor.

The de-magnetization time is the time that must expire between powering-down the drive (OFF2 or a drive inverter fault/error) and powering-up again. The drive inverter is prevented from being powered-up again within this time interval. The flux in the induction motor is reduced to a low value during this de-magnetization time.

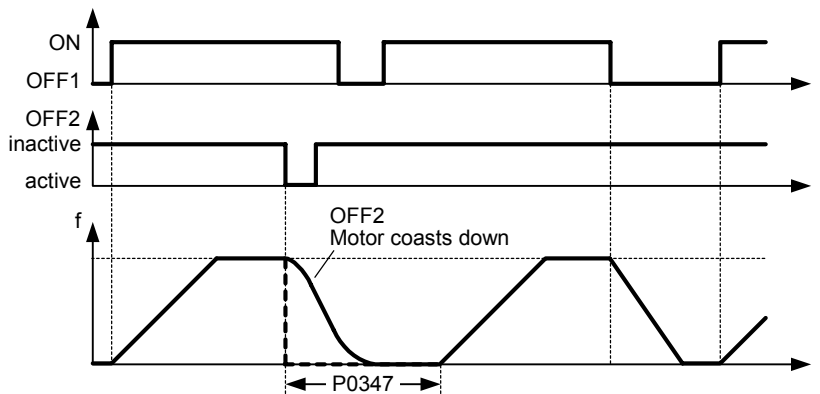

Index:

- P0347[0] : 1st. Drive data set (DDS)
- P0347[1] : 2nd. Drive data set (DDS)
- P0347[2] : 3rd. Drive data set (DDS)

Note:

- The de-magnetization time is approximately 250% of the rotor time constant (r0384) in seconds.
- The pre-assignment (default value) depends on the drive inverter type and its rated/nominal values.
- It is not active after a normal ramp-down - i.e. after OFF1 or OFF3.
- If this time is excessively shortened, then the drive inverter will be tripped (shut down) due to an overcurrent condition.
- If a synchronous motor is connected, the de-magnetization time should be set to 0.

P0350[3]	Stator resistance (line-to-line)	Min: 0.00001	Level 3	
	CStat: CUT	Datatype: Float		Unit: Ohm
	P-Group: MOTOR	Active: Immediately		QuickComm.: No
		Def: 4.00000		
		Max: 2000.00000		

Stator resistance value in [Ohms] for connected motor (from line-to-line). The parameter value includes the cable resistance.

$$P0350 = 2 \cdot (R_{Cable} + R_S)$$

There are three ways to determine the value for this parameter:

1. Calculate using
 - P0340 = 1 (data entered from rating plate) or
 - P0010 = 1, P3900 = 1,2 or 3 (end of quick commissioning).
2. Measure using P1910 = 1 (motor data identification - value for stator resistance is overwritten).
3. Measure manually using an Ohmmeter.

Index:

- P0350[0] : 1st. Drive data set (DDS)
- P0350[1] : 2nd. Drive data set (DDS)
- P0350[2] : 3rd. Drive data set (DDS)

Note:

- Since measured line-to-line, this value may appear to be higher (up to 2 times higher) than expected.
- The value entered in P0350 (stator resistance) is the one obtained by the method last used.
- Default value is depending on inverter type and its rating data.

P0352[3]	Cable resistance	Min: 0.0	Level 3	
	CStat: CUT	Datatype: Float		Unit: Ohm
	P-Group: MOTOR	Active: Immediately		QuickComm.: No
		Def: 0.0		
		Max: 120.0		

Describes cable resistance between inverter and motor for one phase.

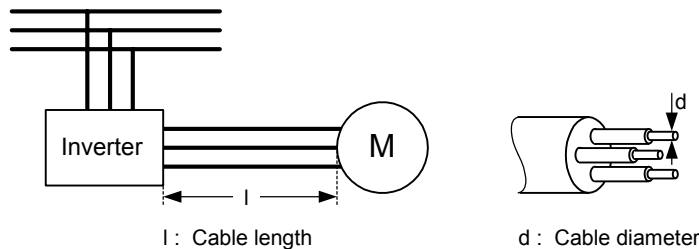

l : Cable length

d : Cable diameter

$$R = \rho \cdot \frac{l}{A}$$

A : Cable cross-section

$$A = \pi \cdot \left(\frac{d}{2}\right)^2$$

ρ : Specific resistance

$$\rho_{Cu} = 0,0178 \frac{\Omega \cdot mm^2}{m}$$

Index:

- P0352[0] : 1st. Drive data set (DDS)
- P0352[1] : 2nd. Drive data set (DDS)
- P0352[2] : 3rd. Drive data set (DDS)

r0384[3]	Rotor time constant	Min: -	Level 3
	Datatype: Float	Unit: ms	
	P-Group: MOTOR	Def: -	
		Max: -	

Displays calculated rotor time constant [ms].

Index:

- r0384[0] : 1st. Drive data set (DDS)
- r0384[1] : 2nd. Drive data set (DDS)
- r0384[2] : 3rd. Drive data set (DDS)

r0395	CO: Total stator resistance [%]	Min: -	Level 3
	Datatype: Float	Unit: %	
	P-Group: MOTOR	Def: -	
		Max: -	

Displays the actual stator resistance (combined stator/cable resistance) of the motor as a [%] as a function of the actual stator winding temperature.

Note:

Actual stator winding temperature, refer to r0632

Rated motor impedance:

$$Z_N = \frac{V_{ph}}{I_{ph}} = \frac{V_N}{\sqrt{3} \cdot I_N} = \frac{P0304}{\sqrt{3} \cdot P0305} \Leftrightarrow 100 \%$$

r0396	CO: Act. rotor resistance	Min: -	Level 3
	P-Group: MOTOR	Datatype: Float Unit: % Def: - Max: -	

Displays the actual rotor resistance of the motor equivalent circuit diagram (phase value) as a [%] as a function of the actual rotor winding temperature.

Note:

- Actual rotor winding temperature, refer to r0633
- Values greater than 25 % tend to produce excessive motor slip. Check rated motor speed [rpm] value (P0311).

Rated motor impedance:

$$Z_N = \frac{V_{ph}}{I_{ph}} = \frac{V_N}{\sqrt{3} \cdot I_N} = \frac{P0304}{\sqrt{3} \cdot P0305} \Leftrightarrow 100 \%$$

3.5 Speed encoder

P0400[3]	Select encoder type	Min: 0	Level 3
	CStat: CT Datatype: U16 Unit: - P-Group: ENCODER Active: Immediately QuickComm.: No Max: 2	Def: 0	

Selects encoder type (number of encoder channels).

Possible Settings:

- 0 Disabled
- 1 Single channel encoder
- 2 Quadrature encoder without zero pulse

Index:

- P0400[0] : 1st. Drive data set (DDS)
- P0400[1] : 2nd. Drive data set (DDS)
- P0400[2] : 3rd. Drive data set (DDS)

Dependency:

Following table displays the setting of P0400 which depends upon the number of encoder channels:

Parameter	Terminal	Track	Encoder output
P0400 = 1	A		single ended
	A AN		differential
P0400 = 2	A		single ended
	B		
	A AN		differential
	B BN		

Following table displays the setting the of the encoder DIPs on the encoder option modul which have to be set depending on the encoder type (TTL, HTL) and encoder output:

Type	Output	
	single ended	differential
TTL (e.g. 1XP8001-2)	111111	010101
HTL (e.g. 1XP8001-1)	101010	000000



Caution:

P0400 = 1 (single channel encoder) will only allow operation in one direction. If operation in both directions is required, connect an encoder with 2 channels (A and B) and select setting 2. See the Operating Instructions of the encoder module for more information.

Note:

Encoders with zero pulse can also be connected, but the zero pulse is not used in MM4.

The term "quadrature" in setting 2 refers to two periodic functions separated by a quarter cycle or 90 degrees.

r0403	CO/BO: Encoder status word	Datatype: U16	Unit: -	Min: -	Level 3
	P-Group: COMMANDS			Def: - Max: -	

Displays status word of encoder (in bit format).

Bitfields:

Bit00	Encoder module active	0	NO	1	YES
Bit01	Encoder error	0	NO	1	YES
Bit02	Signal o.k.	0	NO	1	YES
Bit03	Encoder low speed loss	0	NO	1	YES
Bit04	HW timer used	0	NO	1	YES

Details:

See description of seven-segment display given in the "Introduction to MICROMASTER System Parameters" in this manual.

P0408[3]	Encoder pulses per revolution	Datatype: U16	Unit: -	Min: 2	Level 3
	CStat: CT	Active: Immediately	QuickComm.: No	Def: 1024 Max: 20000	

Specifies the number of encoder pulses per revolution.

Index:

P0408[0] : 1st. Drive data set (DDS)
P0408[1] : 2nd. Drive data set (DDS)
P0408[2] : 3rd. Drive data set (DDS)

Note:

The encoder resolution (pulses per revolution P0408) which may be entered will be limited by the max. pulse frequency of the encoder option board ($f_{\max} = 300$ kHz).

The following equation calculates the encoder frequency depending on the encoder resolution and the rotational speed (rpm). The encoder frequency has to be less than the max. pulse frequency:

$$f_{\max} > f = \frac{p0408 \times \text{rpm}}{60}$$

P0492[3]	Allowed frequency difference	Datatype: Float	Unit: Hz	Min: 0.00	Level 3
	CStat: CT	Active: Immediately	QuickComm.: No	Def: 10.00 Max: 100.00	

Parameter P0492 is used for low and high frequency encoder loss detection (fault: F0090).

- High frequency encoder loss detection:
This condition occurs when the allowed frequency and the allowed difference of the frequency signals between samples, set in P0492 is exceeded.
Condition:
- Act. freq. > P0492 and $f(t_2) - f(t_1) > P0492$
- Low frequency encoder loss detection:
This condition occurs when the actual frequency is < P0492 when encoder loss occurs.
Condition a):
- r0061 = 0 and torque limit and then
- r0061 = 0 with setpoint frequency > 0 for time > P0494
Condition b):
- Act. freq. < P0492 and $f(t_2) < P0492$ and ASIC detect channel B loss

Dependency:

This parameter is updated when motor start-up time P0345 is changed or when a frequency-loop optimisation is performed (P1960 = 1). There is a fixed delay of 40 ms before acting upon loss of encoder at high frequencies.

**Caution:**

P0492 = 0 (disabled):
When allowed frequency difference is set to 0, both the high frequency and low frequency encoder loss detection is disabled, thus encoder loss will not be detected.

If encoder loss detection is disabled and encoder loss occurs, then operation of the motor may become unstable.

P0494[3]	Delay frequency loss reaction				Min: 0	Level 3
	CStat: CUT	Datatype: U16	Unit: ms	Def: 10		
	P-Group: ENCODER	Active: first confirm	QuickComm.: No	Max: 65000		

Used for low frequency encoder loss detection. If the motor shaft frequency is less than the value in P0492 then encoder loss is detected using a low frequency encoder loss detection algorithm. This parameter selects the delay between loss of encoder at low frequency and reaction to the encoder loss.

Index:

P0494[0] : 1st. Drive data set (DDS)
P0494[1] : 2nd. Drive data set (DDS)
P0494[2] : 3rd. Drive data set (DDS)

Dependency:

This parameter is updated when motor start-up time P0345 is changed or when a frequency-loop optimisation is performed (P1960 = 1).

**Caution:**

P0494 = 0 (disabled):
When the delay in P0494 is set to 0, then low frequency encoder loss detection is disabled and low frequency encoder loss cannot be detected (high frequency encoder loss detection will still operate if P0492 > 0).

If low frequency encoder loss detection is disabled and encoder should be lost at low frequency, then operation of motor may become unstable.

3.6 Application macros

P0500[3]	Technological application				Min: 0	Level 3
	CStat: CT	Datatype: U16	Unit: -	Def: 0		
	P-Group: TECH_APL	Active: first confirm	QuickComm.: Yes	Max: 1		

Selects technological application. Sets control mode (P1300).

Possible Settings:

0 Constant torque
1 Pumps and fans

Index:

P0500[0] : 1st. Drive data set (DDS)
P0500[1] : 2nd. Drive data set (DDS)
P0500[2] : 3rd. Drive data set (DDS)

Dependency:

See parameter P0205

3.7 Motor temperature

P0601[3]	Motor temperature sensor	Min: 0	Level
	CStat: CUT	Datatype: U16	Def: 0
	P-Group: MOTOR	Active: first confirm	QuickComm.: No

Selects motor temperature sensor.

Possible Settings:

- 0 No sensor
- 1 PTC thermistor
- 2 KTY84

Index:

- P0601[0] : 1st. Drive data set (DDS)
- P0601[1] : 2nd. Drive data set (DDS)
- P0601[2] : 3rd. Drive data set (DDS)

Dependency:

If "no sensor" is selected, the motor temperature monitoring will be done based on the estimated value of the thermal motor model.

The temperature of the motor, when a thermal sensor is connected is calculated using the thermal motor model. When a KTY sensor is fitted, the loss of connection can be detected (Alarm F0015). Using the methods described above the monitoring of the temperature will automatically switch to the thermal model using values derived from the estimated value. Using a PTC sensor the temperature of the motor is calculated by the sensor in conjunction with the thermal model. This allows for redundancy of the monitoring process.

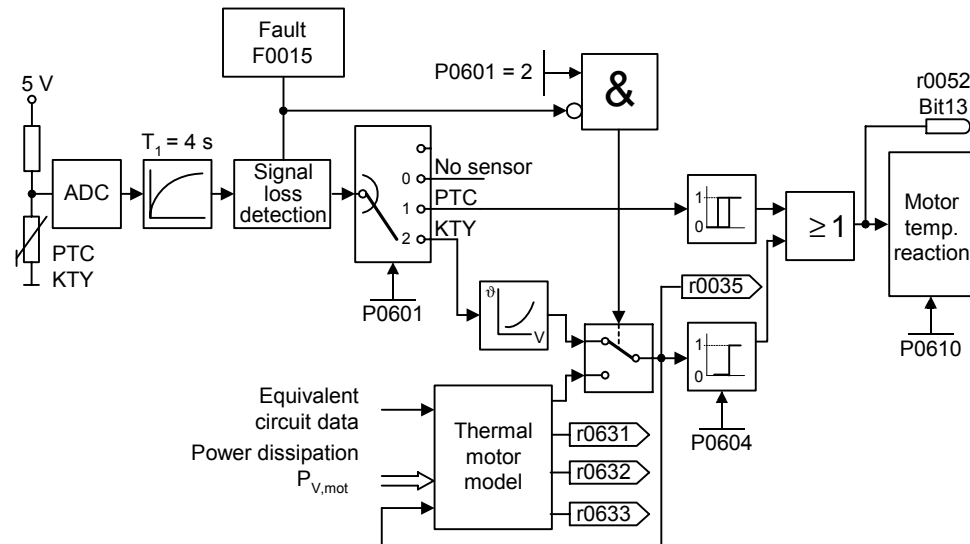

Thermal motor model:

The data, required for the thermal motor model, is estimated from the rating plate data entered during the quick commissioning. This data permits reliable, stable operation for standard Siemens motors. If required, parameter changes must be made for motors from third-party manufacturers. We always recommend that an automatic motor data identification run is made after quick commissioning so that the electrical equivalent circuit diagram data can be determined. This allows a more precise calculation of the losses which occur in the motor which has a positive impact on the accuracy of the thermal motor model.

PTC sensor:

A PTC temperature sensor (Positive-Temperature-Characteristic) is a resistor with a positive temperature characteristic which, at normal temperatures, has a low resistance value (50-100 Ohm). Normally, three PTC temperature sensors are connected in series in the motor (depending on the motor manufacturer), thus producing a "cold resistance value" ranging from 150 to 300 Ohm. PTC temperature sensors are also frequently referred to as cold conductors.

However, at a certain threshold temperature, the resistance rises rapidly. The threshold temperature is selected by the motor manufacturer in such a way that it corresponds to the nominal temperature value of the motor insulation. This allows the change in the resistance value to be deployed to protect the motor, as the PTCs are embedded in the motor windings. PTC temperature sensors are not suitable for measuring temperature.

When the PTC is connected to the control terminals 14 and 15 of the MM4. Once the selection motor temperature sensor has been activated by the setting P0601 = 1 (PTC sensor), the PTC temperature sensor then protects the motor by means of the trip device in the MM4.

Should the resistance value of 2000 Ohm be exceeded, the inverter displays error F0011 (motor overheating).

If the resistance value is below 100 Ohm, the error F0015 (no motor temperature signal) is then output.

This protects the motor from overheating and also from a sensor wire breakage.

The motor is additionally monitored by the thermal motor model in the inverter, thus providing a redundant system for monitoring the motor.

KTY84 sensor:

The sensor KTY84 is basically a semi-conductor thermo-sensor (diode), the resistance value of which varies from some 500 Ohm at 0°C to 2600 Ohm at 300°C. It has a positive temperature coefficient and, in contrast to the PTCs, has an almost linear temperature characteristic. The resistor behaviour is comparable to that of a measuring resistor with a very high temperature coefficient.

Note the following when connecting the polarity. Connect the sensor so that the diode is polarized in the operative direction. That means that the anode needs to be connected to terminal 14 = PTC A (+) and the cathode to terminal 15 = PTC B (-).

If the temperature monitoring function is activated with the setting P0601 = 2, the temperature of the sensor (thus that of the motor windings) is then written to parameter r0035.

The motor overheating warning threshold needs to be assigned with parameter P0604 (the works setting is 130°C). This warning threshold depends on the motor's thermal class. Also refer to the table below in this context.

Extract of IEC 85	
Insulation class	End temperature
Y	90 °C
A	105 °C
E	120 °C
B	130 °C
F	155 °C
H	180 °C

The motor overheating disturbance threshold is automatically set by the inverter at 10% higher than the temperature declared in parameter P0604.

If the sensor KTY84 is activated, the motor temperature is then additionally calculated via the thermal motor model. Should the sensor KTY84 recognise a wire breakage, an alarm F0015 (loss of the motor temperature signal) is then generated and the thermal motor model is automatically switched to.

Connection failure:

If the connection to the PTC or KTY84 sensor becomes open circuit or short circuit, a fault will be indicated, and by default the drive will trip.

P0604[3]	Threshold motor temperature	Min: 0.0	Level 2	
	CStat: CUT	Datatype: Float Unit: °C		Def: 130.0
	P-Group: MOTOR	Active: Immediately QuickComm.: No		Max: 200.0

Enters warning threshold for motor temperature protection.

The trip temperature defined always 10 % higher than the warning level P0604. When act. motor temperature exceeds trip temperature than inverter trip as defined in P0610.

$$\vartheta_{trip} = 1.1 \cdot \vartheta_{warn} = 1.1 \cdot P0604$$

ϑ_{warn} : Warning threshold (P0604)
 ϑ_{trip} : Trip threshold (max. permissible temperature)

Index:

- P0604[0] : 1st. Drive data set (DDS)
- P0604[1] : 2nd. Drive data set (DDS)
- P0604[2] : 3rd. Drive data set (DDS)

Dependency:

This value should be at least 40°C greater than the motor ambient temperature P0625.

$$P0604 \geq P0625 + 40 \text{ °C}$$

Note:

Default value depends on P0300 (select motor type).

P0610[3]	Motor temperature reaction				Min: 0	Level 3
	CStat: CT	Datatype: U16	Unit: -	Def: 2		
	P-Group: MOTOR	Active: first confirm	QuickComm.: No	Max: 2		

Defines reaction when motor temperature reaches warning threshold.

Possible Settings:

- 0 Warning, no reaction, no trip
- 1 Warning, I_{max} reduction, trip F0011
- 2 Warning, no reaction, trip F0011

Index:

- P0610[0] : 1st. Drive data set (DDS)
- P0610[1] : 2nd. Drive data set (DDS)
- P0610[2] : 3rd. Drive data set (DDS)

Dependency:

$$\vartheta_{trip} = 1.1 \cdot \vartheta_{warn} = 1.1 \cdot P0604 \quad \vartheta_{warn} : \text{Warning threshold (P0604)}$$

$$\vartheta_{trip} : \text{Trip threshold (max. permissible temperature)}$$

Note:

P0610 = 1:
If the max. permissible current I_{max} is reduced, this results in a lower output frequency.

The motor temperature depends on many factors. These factors include the size of the motor, the ambient temperature, the previous motor load and naturally the load current.

Because most motors are cooled by fans integrated in the motor and running at the motor speed, the speed of the motor is also important. Clearly a motor running with a high current (maybe due to boost) and a low speed, will overheat more quickly than one running at 50 or 60 Hz, full load. The MM4 take account of these factors.

P0625[3]	Ambient motor temperature				Min: -40.0	Level 3
	CStat: CUT	Datatype: Float	Unit: °C	Def: 20.0		
	P-Group: MOTOR	Active: Immediately	QuickComm.: No	Max: 80.0		

Ambient temperature of motor. The parameter for the stator resistance P0350 and rotor resistance P0354 relate to the ambient temperature.

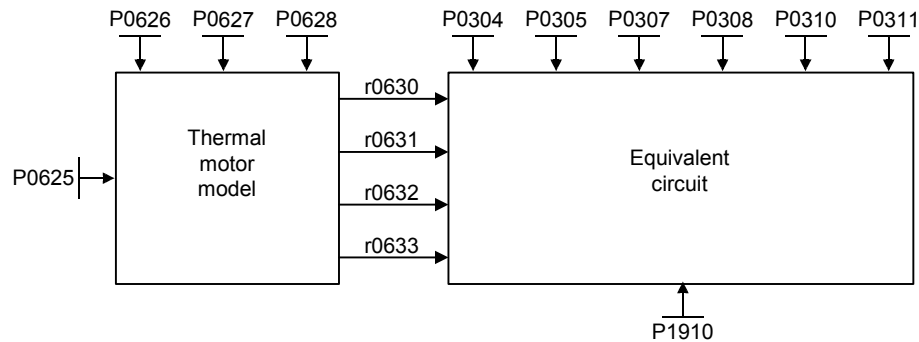

Index:

- P0625[0] : 1st. Drive data set (DDS)
- P0625[1] : 2nd. Drive data set (DDS)
- P0625[2] : 3rd. Drive data set (DDS)

Note:

- Following items should be considered when using P0625:
- The ambient temperature has to be entered prior to motor data identification.
 - An accuracy of +/- 5°C is adequate.
 - The motor data identification should be carried out on a cold motor (ambient temperature = stator temperature = rotor temperature).
 - The highest accuracy at temperature adaption of the stator resistance and rotor resistance can be achieved by connecting a KTY84 sensor.

P0640[3]	Motor overload factor [%]				Min: 10.0	Level 3
	CStat: CUT	Datatype: Float	Unit: %	Def: 110.0		
	P-Group: MOTOR	Active: Immediately	QuickComm.: Yes	Max: 400.0		

Defines motor overload current limit in [%] relative to P0305 (rated motor current).

Index:

P0640[0] : 1st. Drive data set (DDS)
P0640[1] : 2nd. Drive data set (DDS)
P0640[2] : 3rd. Drive data set (DDS)

Dependency:

Limited to maximum inverter current or to 400 % of rated motor current (P0305), whichever is the lower.

$$P0640_{\max} = \frac{\min(r0209, 4 \cdot P0305)}{P0305} \cdot 100$$

Details:

See function diagram for current limitation.

3.8 Command source

P0700[3]	Selection of command source	Min: 0	Level 1	
	CStat: CT	Datatype: U16		Unit: -
	P-Group: COMMANDS	Active: first confirm		QuickComm.: Yes
				Def: 2
		Max: 6		

Selects digital command source.

Possible Settings:

- 0 Factory default setting
- 1 BOP (keypad)
- 2 Terminal
- 4 USS on BOP link
- 5 USS on COM link
- 6 CB on COM link

Index:

- P0700[0] : 1st. Command data set (CDS)
- P0700[1] : 2nd. Command data set (CDS)
- P0700[2] : 3rd. Command data set (CDS)

Example:

Changing from P0700 = 1 to P0700 = 2 sets all digital inputs to default settings.

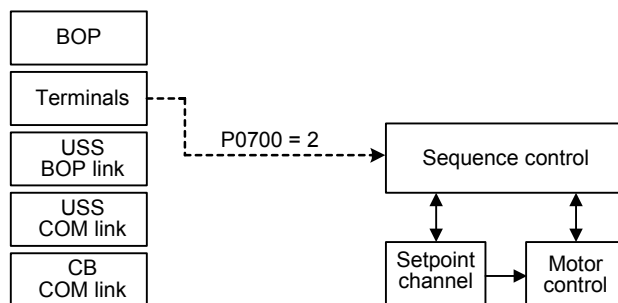

Caution:

Be aware, by changing of parameter P0700 all BI parameters are reset to the default value or modified as listed in the table below.

Note:

Changing this parameter sets (to default) all settings on item selected (see table).

	P0700 = 0	P0700 = 1	P0700 = 2	P0700 = 4	P0700 = 5	P0700 = 6
P0701	1	0	1	0	0	0
P0702	12	0	12	0	0	0
P0703	9	9	9	9	9	9
P0704	15	15	15	15	15	15
P0705	15	15	15	15	15	15
P0706	15	15	15	15	15	15
P0707	0	0	0	0	0	0
P0708	0	0	0	0	0	0
P0731	52.3	52.3	52.3	52.3	52.3	52.3
P0732	52.7	52.7	52.7	52.7	52.7	52.7
P0733	0.0	0.0	0.0	0.0	0.0	0.0
P0800	0.0	0.0	0.0	0.0	0.0	0.0
P0801	0.0	0.0	0.0	0.0	0.0	0.0

P0840	722.0	19.0	722.0	2032.0	2036.0	2090.0
P0842	0.0	0.0	0.0	0.0	0.0	0.0
P0844	1.0	19.1	1.0	2032.1	2036.1	2090.1
P0845	19.1	19.1	19.1	19.1	19.1	19.1
P0848	1.0	1.0	1.0	2032.2	2036.2	2090.2
P0849	1.0	1.0	1.0	1.0	1.0	1.0
P0852	1.0	1.0	1.0	2032.3	2036.3	2090.3
	P0700 = 0	P0700 = 1	P0700 = 2	P0700 = 4	P0700 = 5	P0700 = 6
P1020	0.0	0.0	0.0	0.0	0.0	0.0
P1021	0.0	0.0	0.0	0.0	0.0	0.0
P1022	0.0	0.0	0.0	0.0	0.0	0.0
P1023	722.3	722.3	722.3	722.3	722.3	722.3
P1026	722.4	722.4	722.4	722.4	722.4	722.4
P1028	722.5	722.5	722.5	722.5	722.5	722.5
P1035	19.13	19.13	19.13	2032.13	2036.13	2090.13
P1036	19.14	19.14	19.14	2032.14	2036.14	2090.14
P1074	0.0	0.0	0.0	0.0	0.0	0.0
P1110	1.0	1.0	1.0	1.0	1.0	1.0
P1113	722.1	0.0	722.1	2032.11	2036.11	2090.11
P1140	1.0	1.0	1.0	2032.4	2036.4	2090.4
P1141	1.0	1.0	1.0	2032.5	2036.5	2090.5
P1142	1.0	1.0	1.0	2032.6	2036.6	2090.6
P1230	0.0	0.0	0.0	0.0	0.0	0.0
P1266	0.0	0.0	0.0	0.0	0.0	0.0
P2103	722.2	722.2	722.2	722.2	722.2	722.2
P2104	0.0	0.0	0.0	2032.7	2036.7	2090.7
P2106	1.0	1.0	1.0	1.0	1.0	1.0
P2200	0.0	0.0	0.0	0.0	0.0	0.0
P2220	0.0	0.0	0.0	0.0	0.0	0.0
P2221	0.0	0.0	0.0	0.0	0.0	0.0
P2222	0.0	0.0	0.0	0.0	0.0	0.0
P2223	722.3	722.3	722.3	722.3	722.3	722.3
P2226	722.4	722.4	722.4	722.4	722.4	722.4
P2228	722.5	722.5	722.5	722.5	722.5	722.5
P2235	19.13	19.13	19.13	2032.13	2036.13	2090.13
P2236	19.14	19.14	19.14	2032.14	2036.14	2090.14

The following parameters are not overwritten when changing P0700:

P0810	P0811	P0820	P0821	P2810	P2812	P2814
P2816	P2818	P2820	P2822	P2824	P2826	P2828
P2830	P2832	P2834	P2837	P2840	P2843	P2846
P2849	P2854	P2859	P2864			

P0702[3]	Function of digital input 2				Min: 0	Level 2
	CStat: CT	Datatype: U16	Unit: -	Def: 12		
	P-Group: COMMANDS	Active: first confirm	QuickComm.: No	Max: 99		

Selects function of digital input 2.

Possible Settings:

- 0 Digital input disabled
- 1 ON/OFF1
- 2 ON reverse /OFF1
- 3 OFF2 - coast to standstill
- 4 OFF3 - quick ramp-down
- 9 Fault acknowledge
- 10 reserved
- 11 reserved
- 12 Reverse
- 13 MOP up (increase frequency)
- 14 MOP down (decrease frequency)
- 15 Fixed setpoint (Direct selection)
- 16 Fixed setpoint (Direct selection + ON)
- 17 Fixed setpoint (Binary coded selection + ON)
- 25 DC brake enable
- 26 reserved
- 27 Enable PID
- 28 Bypass mode command input
- 29 External trip
- 33 Disable additional freq setpoint
- 99 Enable BICO parameterization

Index:

- P0702[0] : 1st. Command data set (CDS)
- P0702[1] : 2nd. Command data set (CDS)
- P0702[2] : 3rd. Command data set (CDS)

Details:

See P0701 (function of digital input1).

P0703[3]	Function of digital input 3				Min: 0	Level 2
	CStat: CT	Datatype: U16	Unit: -	Def: 9		
	P-Group: COMMANDS	Active: first confirm	QuickComm.: No	Max: 99		

Selects function of digital input 3.

Possible Settings:

- 0 Digital input disabled
- 1 ON/OFF1
- 2 ON reverse /OFF1
- 3 OFF2 - coast to standstill
- 4 OFF3 - quick ramp-down
- 9 Fault acknowledge
- 10 reserved
- 11 reserved
- 12 Reverse
- 13 MOP up (increase frequency)
- 14 MOP down (decrease frequency)
- 15 Fixed setpoint (Direct selection)
- 16 Fixed setpoint (Direct selection + ON)
- 17 Fixed setpoint (Binary coded selection + ON)
- 25 DC brake enable
- 26 reserved
- 27 Enable PID
- 28 Bypass mode command input
- 29 External trip
- 33 Disable additional freq setpoint
- 99 Enable BICO parameterization

Index:

- P0703[0] : 1st. Command data set (CDS)
- P0703[1] : 2nd. Command data set (CDS)
- P0703[2] : 3rd. Command data set (CDS)

Details:

See P0701 (function of digital input 1).

P0704[3]	Function of digital input 4				Min: 0	Level 2
	CStat: CT	Datatype: U16	Unit: -	Def: 15		
	P-Group: COMMANDS	Active: first confirm	QuickComm.: No	Max: 99		

Selects function of digital input 4.

Possible Settings:

- 0 Digital input disabled
- 1 ON/OFF1
- 2 ON reverse /OFF1
- 3 OFF2 - coast to standstill
- 4 OFF3 - quick ramp-down
- 9 Fault acknowledge
- 10 reserved
- 11 reserved
- 12 Reverse
- 13 MOP up (increase frequency)
- 14 MOP down (decrease frequency)
- 15 Fixed setpoint (Direct selection)
- 16 Fixed setpoint (Direct selection + ON)
- 17 Fixed setpoint (Binary coded selection + ON)
- 25 DC brake enable
- 26 reserved
- 27 Enable PID
- 28 Bypass mode command input
- 29 External trip
- 33 Disable additional freq setpoint
- 99 Enable BICO parameterization

Index:

- P0704[0] : 1st. Command data set (CDS)
- P0704[1] : 2nd. Command data set (CDS)
- P0704[2] : 3rd. Command data set (CDS)

Details:

See P0701 (function of digital input 1).

P0705[3]	Function of digital input 5				Min: 0	Level 2
	CStat: CT	Datatype: U16	Unit: -	Def: 15		
	P-Group: COMMANDS	Active: first confirm	QuickComm.: No	Max: 99		

Selects function of digital input 5.

Possible Settings:

- 0 Digital input disabled
- 1 ON/OFF1
- 2 ON reverse /OFF1
- 3 OFF2 - coast to standstill
- 4 OFF3 - quick ramp-down
- 9 Fault acknowledge
- 10 reserved
- 11 reserved
- 12 Reverse
- 13 MOP up (increase frequency)
- 14 MOP down (decrease frequency)
- 15 Fixed setpoint (Direct selection)
- 16 Fixed setpoint (Direct selection + ON)
- 17 Fixed setpoint (Binary coded selection + ON)
- 25 DC brake enable
- 26 reserved
- 27 Enable PID
- 28 Bypass mode command input
- 29 External trip
- 33 Disable additional freq setpoint
- 99 Enable BICO parameterization

Index:

- P0705[0] : 1st. Command data set (CDS)
- P0705[1] : 2nd. Command data set (CDS)
- P0705[2] : 3rd. Command data set (CDS)

Details:

See P0701 (function of digital input 1).

P0706[3]	Function of digital input 6				Min: 0	Level 2
	CStat: CT	Datatype: U16	Unit: -	Def: 15		
	P-Group: COMMANDS	Active: first confirm	QuickComm.: No	Max: 99		

Selects function of digital input 6.

Possible Settings:

- 0 Digital input disabled
- 1 ON/OFF1
- 2 ON reverse /OFF1
- 3 OFF2 - coast to standstill
- 4 OFF3 - quick ramp-down
- 9 Fault acknowledge
- 10 reserved
- 11 reserved
- 12 Reverse
- 13 MOP up (increase frequency)
- 14 MOP down (decrease frequency)
- 15 Fixed setpoint (Direct selection)
- 16 Fixed setpoint (Direct selection + ON)
- 17 Fixed setpoint (Binary coded selection + ON)
- 25 DC brake enable
- 26 reserved
- 27 Enable PID
- 28 Bypass mode command input
- 29 External trip
- 33 Disable additional freq setpoint
- 99 Enable BICO parameterization

Index:

- P0706[0] : 1st. Command data set (CDS)
- P0706[1] : 2nd. Command data set (CDS)
- P0706[2] : 3rd. Command data set (CDS)

Details:

See P0701 (function of digital input 1).

P0707[3]	Function of digital input 7				Min: 0	Level 3
	CStat: CT	Datatype: U16	Unit: -	Def: 0		
	P-Group: COMMANDS	Active: first confirm	QuickComm.: No	Max: 99		

Selects function of digital input 7 (via analog input).

Possible Settings:

- 0 Digital input disabled
- 1 ON/OFF1
- 2 ON reverse /OFF1
- 3 OFF2 - coast to standstill
- 4 OFF3 - quick ramp-down
- 9 Fault acknowledge
- 10 reserved
- 11 reserved
- 12 Reverse
- 13 MOP up (increase freq.)
- 14 MOP down (decrease freq.)
- 25 DC brake enable
- 26 reserved
- 28 Bypass mode command input
- 29 External trip
- 33 Disable additional freq setpoint
- 99 Enable BICO parameterization

Index:

- P0707[0] : 1st. Command data set (CDS)
- P0707[1] : 2nd. Command data set (CDS)
- P0707[2] : 3rd. Command data set (CDS)

Note:

Signals above 4 V are active, signals below 1,6 V are inactive.

Details:

See P0701 (function of digital input 1).

P0708[3]	Function of digital input 8				Min: 0	Level 3
	CStat: CT	Datatype: U16	Unit: -	Def: 0		
	P-Group: COMMANDS	Active: first confirm	QuickComm.: No	Max: 99		

Selects function of digital input 8 (via analog input)

Possible Settings:

- 0 Digital input disabled
- 1 ON/OFF1
- 2 ON reverse /OFF1
- 3 OFF2 - coast to standstill
- 4 OFF3 - quick ramp-down
- 9 Fault acknowledge
- 10 reserved
- 11 reserved
- 12 Reverse
- 13 MOP up (increase freq.)
- 14 MOP down (decrease freq.)
- 25 DC brake enable
- 26 reserved
- 28 Bypass mode command input
- 29 External trip
- 33 Disable additional freq setpoint
- 99 Enable BICO parameterization

Index:

- P0708[0] : 1st. Command data set (CDS)
- P0708[1] : 2nd. Command data set (CDS)
- P0708[2] : 3rd. Command data set (CDS)

Note:

Signals above 4 V are active, signals below 1,6 V are inactive.

Details:

See P0701 (function of digital input 1).

P0718	CO/BO: Hand / Auto				Min: 0	Level 3
	CStat: CUT	Datatype: U16	Unit: -	Def: 0		
	P-Group: COMMANDS	Active: Immediately	QuickComm.: No	Max: 1		

From a defaulted drive

- 0 = Auto operation i.e. the control from the analogue and digital inputs
- 1 = Hand operation i.e. the control comes from the BOP

Using the Hand / Auto buttons on the BOP will change this parameter.

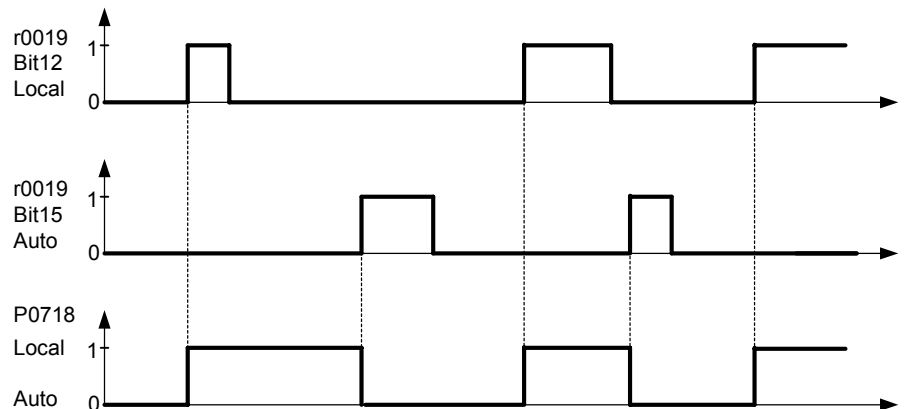

Default:

P0810 = 718:0 ⇒ Local/Auto ⇔ CDS1/CDS2

- P0718 = 0 : P0700[0] = 2 (Terminal)
P1000[0] = 2 (ADC)
- P0718 = 1 : P0700[1] = 1 (BOP)
P1000[1] = 1 (MOP)

Note:

Changing CDS values will effect the operation of Hand / Auto

P0719[3]	Selection of cmd. & freq. setp.				Min: 0	Level 3
	CStat: CT	Datatype: U16	Unit: -	Def: 0		
	P-Group: COMMANDS	Active: first confirm	QuickComm.: No	Max: 66		

Central switch to select control command source for inverter.

Switches command and setpoint source between freely programmable BICO parameters and fixed command/setpoint profiles. Command and setpoint sources can be changed independently.

The tens digit chooses the command source and the units digit chooses the setpoint source.

Possible Settings:

0	Cmd = BICO parameter	Setpoint = BICO parameter
1	Cmd = BICO parameter	Setpoint = MOP setpoint
2	Cmd = BICO parameter	Setpoint = Analog setpoint
3	Cmd = BICO parameter	Setpoint = Fixed frequency
4	Cmd = BICO parameter	Setpoint = USS on BOP link
5	Cmd = BICO parameter	Setpoint = USS on COM link
6	Cmd = BICO parameter	Setpoint = CB on COM link
10	Cmd = BOP	Setpoint = BICO parameter
11	Cmd = BOP	Setpoint = MOP setpoint
12	Cmd = BOP	Setpoint = Analog setpoint
13	Cmd = BOP	Setpoint = Fixed frequency
15	Cmd = BOP	Setpoint = USS on COM link
16	Cmd = BOP	Setpoint = CB on COM link
40	Cmd = USS on BOP link	Setpoint = BICO parameter
41	Cmd = USS on BOP link	Setpoint = MOP setpoint
42	Cmd = USS on BOP link	Setpoint = Analog setpoint
43	Cmd = USS on BOP link	Setpoint = Fixed frequency
44	Cmd = USS on BOP link	Setpoint = USS on BOP link
45	Cmd = USS on BOP link	Setpoint = USS on COM link
46	Cmd = USS on BOP link	Setpoint = CB on COM link
50	Cmd = USS on COM link	Setpoint = BICO parameter
51	Cmd = USS on COM link	Setpoint = MOP setpoint
52	Cmd = USS on COM link	Setpoint = Analog setpoint
53	Cmd = USS on COM link	Setpoint = Fixed frequency
54	Cmd = USS on COM link	Setpoint = USS on BOP link
55	Cmd = USS on COM link	Setpoint = USS on COM link
60	Cmd = CB on COM link	Setpoint = BICO parameter
61	Cmd = CB on COM link	Setpoint = MOP setpoint
62	Cmd = CB on COM link	Setpoint = Analog setpoint
63	Cmd = CB on COM link	Setpoint = Fixed frequency
64	Cmd = CB on COM link	Setpoint = USS on BOP link
66	Cmd = CB on COM link	Setpoint = CB on COM link

Index:

P0719[0] : 1st. Command data set (CDS)
 P0719[1] : 2nd. Command data set (CDS)
 P0719[2] : 3rd. Command data set (CDS)

Note:

BICO connections made previously remain unchanged.

r0720	Number of digital inputs				Min: -	Level 3
	Datatype: U16	Unit: -	Def: -	Max: -		
	P-Group: COMMANDS					

Displays number of digital inputs.

r0722	CO/BO: Binary input values				Min: -	Level 3
	Datatype: U16	Unit: -	Def: -	Max: -		
	P-Group: COMMANDS					

Displays status of digital inputs.

Bitfields:

Bit00	Digital input 1	0	OFF	1	ON
Bit01	Digital input 2	0	OFF	1	ON
Bit02	Digital input 3	0	OFF	1	ON
Bit03	Digital input 4	0	OFF	1	ON
Bit04	Digital input 5	0	OFF	1	ON
Bit05	Digital input 6	0	OFF	1	ON
Bit06	Digital input 7 (via ADC 1)	0	OFF	1	ON
Bit07	Digital input 8 (via ADC 2)	0	OFF	1	ON

Note:

Segment is lit when signal is active.

P0724	Debounce time for digital inputs				Min: 0	Level 3
	CStat: CT	Datatype: U16	Unit: -	Def: 3		
	P-Group: COMMANDS	Active: Immediately	QuickComm.: No	Max: 3		

Defines debounce time (filtering time) used for digital inputs.

Possible Settings:

- 0 No debounce time
- 1 2.5 ms debounce time
- 2 8.2 ms debounce time
- 3 12.3 ms debounce time

P0725	PNP / NPN digital inputs				Min: 0	Level 3
	CStat: CT	Datatype: U16	Unit: -	Def: 1		
	P-Group: COMMANDS	Active: Immediately	QuickComm.: No	Max: 1		

Switches between active high (PNP) and active low (NPN). This is valid for all digital inputs simultaneously.

The following is valid by using the internal supply:

Possible Settings:

- 0 NPN mode ==> low active
- 1 PNP mode ==> high active

Value:

NPN: Terminals 5/6/7/8/16/17 must be connected via terminal 28 (0 V).
PNP: Terminals 5/6/7/8/16/17 must be connected via terminal 9 (24 V).

3.10 Digital outputs

r0730	Number of digital outputs	Datatype: U16	Unit: -	Min: -	Level 3
	P-Group: COMMANDS			Def: - Max: -	

Displays number of digital outputs (relays).

P0731[3]	BI: Function of digital output 1	Datatype: U32	Unit: -	Min: 0:0	Level 2
	CStat: CUT	Active: first confirm	QuickComm.: No	Def: 52:3 Max: 4000:0	

Defines source of digital output 1.

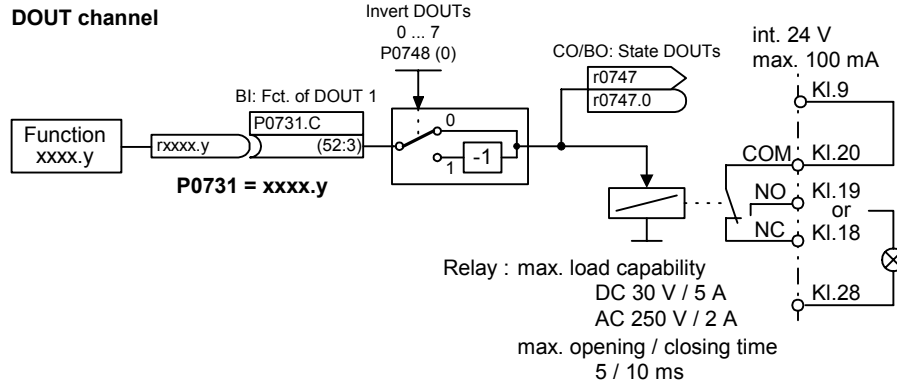

Index:

- P0731[0] : 1st. Command data set (CDS)
- P0731[1] : 2nd. Command data set (CDS)
- P0731[2] : 3rd. Command data set (CDS)

Common Settings:

52.0	Drive ready	0	Closed
52.1	Drive ready to run	0	Closed
52.2	Drive running	0	Closed
52.3	Drive fault active	0	Closed
52.4	OFF2 active	1	Closed
52.5	OFF3 active	1	Closed
52.6	Switch on inhibit active	0	Closed
52.7	Drive warning active	0	Closed
52.8	Deviation setpoint/actual value	1	Closed
52.9	PZD control (Process Data Control)	0	Closed
52.A	Maximum frequency reached	0	Closed
52.B	Warning: Motor current limit	1	Closed
52.C	Motor holding brake (MHB) active	0	Closed
52.D	Motor overload	1	Closed
52.E	Motor running direction right	0	Closed
52.F	Inverter overload	1	Closed
53.0	DC brake active	0	Closed
53.1	Act. freq. $f_{act} > P2167 (f_{off})$	0	Closed
53.2	Act. freq. $f_{act} \leq P1080 (f_{min})$	0	Closed
53.3	Act. current $r0027 > P2170$	0	Closed
53.4	Act. freq. $f_{act} > P2155 (f_1)$	0	Closed
53.5	Act. freq. $f_{act} \leq P2155 (f_1)$	0	Closed
53.6	Act. freq. $f_{act} \geq \text{setpoint}$	0	Closed
53.7	Act. Vdc $r0026 < P2172$	0	Closed
53.8	Act. Vdc $r0026 > P2172$	0	Closed
53.A	PID output $r2294 == P2292 (PID_{min})$	0	Closed
53.B	PID output $r2294 == P2291 (PID_{max})$	0	Closed

P0732[3]	BI: Function of digital output 2				Min: 0:0	Level 2
	CStat: CUT	Datatype: U32	Unit: -	Def: 52:7		
	P-Group: COMMANDS	Active: first confirm	QuickComm.: No	Max: 4000:0		

Defines source of digital output 2.

Index:

- P0732[0] : 1st. Command data set (CDS)
- P0732[1] : 2nd. Command data set (CDS)
- P0732[2] : 3rd. Command data set (CDS)

Common Settings:

52.0	Drive ready	0	Closed
52.1	Drive ready to run	0	Closed
52.2	Drive running	0	Closed
52.3	Drive fault active	0	Closed
52.4	OFF2 active	1	Closed
52.5	OFF3 active	1	Closed
52.6	Switch on inhibit active	0	Closed
52.7	Drive warning active	0	Closed
52.8	Deviation setpoint/actual value	1	Closed
52.9	PZD control (Process Data Control)	0	Closed
52.A	Maximum frequency reached	0	Closed
52.B	Warning: Motor current limit	1	Closed
52.C	Motor holding brake (MHB) active	0	Closed
52.D	Motor overload	1	Closed
52.E	Motor running direction right	0	Closed
52.F	Inverter overload	1	Closed
53.0	DC brake active	0	Closed
53.1	Act. freq. f_act > P2167 (f_off)	0	Closed
53.2	Act. freq. f_act <= P1080 (f_min)	0	Closed
53.3	Act. current r0027 > P2170	0	Closed
53.4	Act. freq. f_act > P2155 (f_1)	0	Closed
53.5	Act. freq. f_act <= P2155 (f_1)	0	Closed
53.6	Act. freq. f_act >= setpoint	0	Closed
53.7	Act. Vdc r0026 < P2172	0	Closed
53.8	Act. Vdc r0026 > P2172	0	Closed
53.A	PID output r2294 == P2292 (PID_min)	0	Closed
53.B	PID output r2294 == P2291 (PID_max)	0	Closed

P0733[3]	BI: Function of digital output 3				Min: 0:0	Level 2
	CStat: CUT	Datatype: U32	Unit: -	Def: 0:0		
	P-Group: COMMANDS	Active: first confirm	QuickComm.: No	Max: 4000:0		

Defines source of digital output 3.

Index:

- P0733[0] : 1st. Command data set (CDS)
- P0733[1] : 2nd. Command data set (CDS)
- P0733[2] : 3rd. Command data set (CDS)

Common Settings:

52.0	Drive ready	0	Closed
52.1	Drive ready to run	0	Closed
52.2	Drive running	0	Closed
52.3	Drive fault active	0	Closed
52.4	OFF2 active	1	Closed
52.5	OFF3 active	1	Closed
52.6	Switch on inhibit active	0	Closed
52.7	Drive warning active	0	Closed
52.8	Deviation setpoint/actual value	1	Closed
52.9	PZD control (Process Data Control)	0	Closed
52.A	Maximum frequency reached	0	Closed
52.B	Warning: Motor current limit	1	Closed
52.C	Motor holding brake (MHB) active	0	Closed
52.D	Motor overload	1	Closed
52.E	Motor running direction right	0	Closed
52.F	Inverter overload	1	Closed
53.0	DC brake active	0	Closed
53.1	Act. freq. f_act > P2167 (f_off)	0	Closed
53.2	Act. freq. f_act <= P1080 (f_min)	0	Closed
53.3	Act. current r0027 > P2170	0	Closed
53.4	Act. freq. f_act > P2155 (f_1)	0	Closed
53.5	Act. freq. f_act <= P2155 (f_1)	0	Closed
53.6	Act. freq. f_act >= setpoint	0	Closed
53.7	Act. Vdc r0026 < P2172	0	Closed
53.8	Act. Vdc r0026 > P2172	0	Closed
53.A	PID output r2294 == P2292 (PID_min)	0	Closed
53.B	PID output r2294 == P2291 (PID_max)	0	Closed

r0747	CO/BO: State of digital outputs	Datatype: U16	Unit: -	Min: -	Def: -	Max: -	Level 3
	P-Group: COMMANDS						

Displays status of digital outputs (also includes inversion of digital outputs via P0748).

Bitfields:

Bit00	Digital output 1 energized	0	NO	1	YES
Bit01	Digital output 2 energized	0	NO	1	YES
Bit02	Digital output 3 energized	0	NO	1	YES

Dependency:

Bit 0 = 0 :
Relay de-energized / contacts open

Bit 0 = 1 :
Relay energized / contacts closed

P0748	Invert digital outputs	Datatype: U16	Unit: -	Min: 0	Def: 0	Max: 7	Level 3
	CStat: CUT	Active: first confirm	QuickComm.: No				

Defines high and low states of relay for a given function.

Bitfields:

Bit00	Invert digital output 1	0	NO	1	YES
Bit01	Invert digital output 2	0	NO	1	YES
Bit02	Invert digital output 3	0	NO	1	YES

3.11 Analog inputs

r0750	Number of ADCs	Datatype: U16	Unit: -	Min: -	Def: -	Max: -	Level 3
	P-Group: TERMINAL						

Displays number of analog inputs available.

r0752[2]	Act. input of ADC [V] or [mA]	Datatype: Float	Unit: -	Min: -	Def: -	Max: -	Level 2
	P-Group: TERMINAL						

Displays smoothed analog input value in volts before the characteristic block.

ADC channel

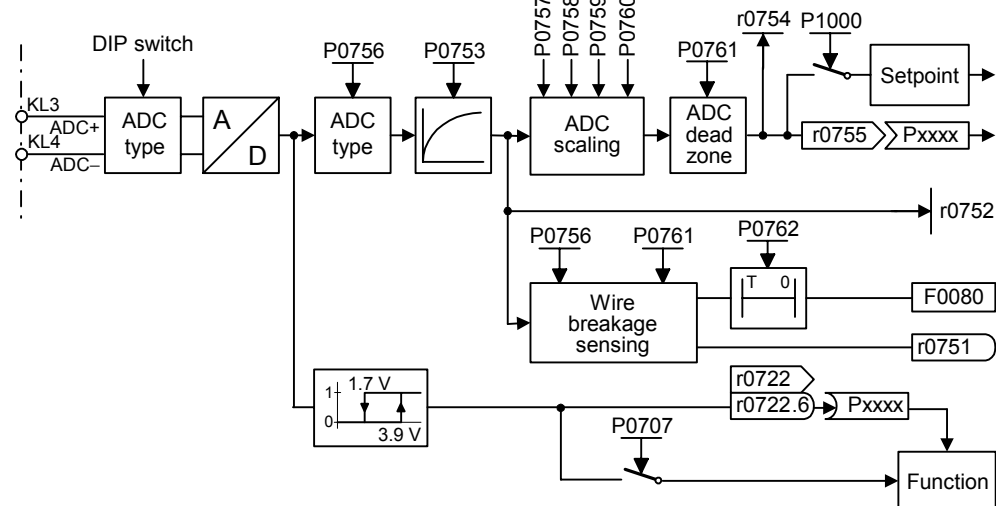

Index:

- r0752[0] : Analog input 1 (ADC 1)
- r0752[1] : Analog input 2 (ADC 2)

P0753[2]	Smooth time ADC	Min: 0	Level 3	
	CStat: CUT	Datatype: U16		Unit: ms
	P-Group: TERMINAL	Active: first confirm		QuickComm.: No

Defines filter time (PT1 filter) in [ms] for analog input.

Index:

P0753[0] : Analog input 1 (ADC 1)
P0753[1] : Analog input 2 (ADC 2)

Note:

Increasing this time (smooth) reduces jitter but slows down response to the analog input.

P0753 = 0 : No filtering

r0754[2]	Act. ADC value after scaling [%]	Min: -	Level 2	
	Datatype: Float	Unit: %		Def: -
	P-Group: TERMINAL	Max: -		Max: -

Shows smoothed value of analog input in [%] after scaling block.

Index:

r0754[0] : Analog input 1 (ADC 1)
r0754[1] : Analog input 2 (ADC 2)

Dependency:

P0757 to P0760 define range (ADC scaling).

r0755[2]	CO: Act. ADC after scal. [4000h]	Min: -	Level 3	
	Datatype: I16	Unit: -		Def: -
	P-Group: TERMINAL	Max: -		Max: -

Displays analog input, scaled using ASPmin and ASPmax.

Analog setpoint (ASP) from the analog scaling block can vary from min. analog setpoint (ASPmin) to a max. analog setpoint (ASPmax) as shown in P0757 (ADC scaling).

The largest magnitude (value without sign) of ASPmin and ASPmax defines the scaling of 16384.

By associating parameter r0755 with an internal value (e.g. frequency setpoint), a scaled value is calculated internally by the MM4. The frequency value is calculated using the following equation:

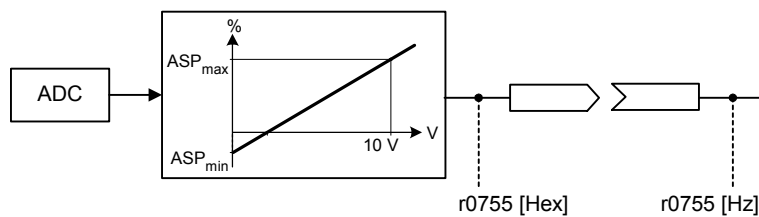

$$r0755 \text{ [Hz]} = \frac{r0755 \text{ [Hex]}}{4000 \text{ [Hex]}} \cdot P2000 \cdot \frac{\max(|ASP_{max}|, |ASP_{min}|)}{100\%}$$

Index:

r0755[0] : Analog input 1 (ADC 1)
r0755[1] : Analog input 2 (ADC 2)

Example:

Case a:

- ASPmin = 300 %, ASPmax = 100 % then 16384 represents 300 %.
- This parameter will vary from 5461 to 16384.

Case b:

- ASPmin = -200 %, ASPmax = 100 % then 16384 represents 200 %.
- This parameter will vary from -16384 to +8192.

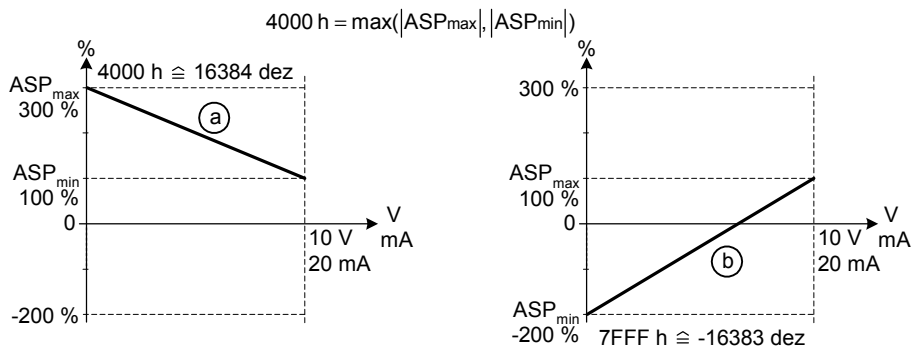

Note:

- This value is used as an input to analog BICO connectors.
- ASPmax represents the highest analog setpoint (this may be at 10 V).
- ASPmin represents the lowest analog setpoint (this may be at 0 V).

Details:

See parameters P0757 to P0760 (ADC scaling)

P0756[2]	Type of ADC			Min: 0	Level 2
	CStat: CT	Datatype: U16	Unit: -	Def: 0	
	P-Group: TERMINAL	Active: first confirm	QuickComm.: No	Max: 4	

Defines type of analog input and also enables analog input monitoring.

To switch over from voltage to current analog input it is not sufficient to merely modify parameter P0756. Rather, the DIPs on the terminal board must also be set to the correct position. The DIP settings are as follows:

- OFF = voltage input (10 V)
- ON = current input (20 mA)

Allocation of DIPs to analog inputs is as follows:

- DIP on left (DIP 1) = Analog input 1
- DIP on right (DIP 2) = Analog input 2

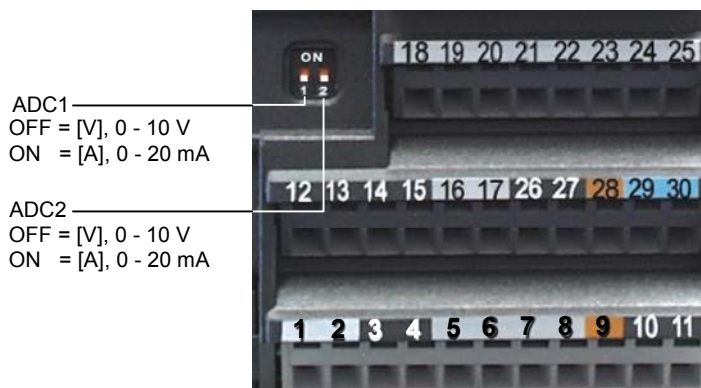

Possible Settings:

- 0 Unipolar voltage input (0 to +10 V)
- 1 Unipolar voltage input with monitoring (0 to 10 V)
- 2 Unipolar current input (0 to 20 mA)
- 3 Unipolar current input with monitoring (0 to 20 mA)
- 4 Bipolar voltage input (-10 V to +10 V)

Index:

P0756[0] : Analog input 1 (ADC 1)
 P0756[1] : Analog input 2 (ADC 2)

Notice:

When monitoring is enabled and a deadband defined (P0761), a fault condition will be generated (F0080) if the analog input voltage falls below 50 % of the deadband voltage.

On account of h/w restriction it is not possible to select the bipolar voltage (see Enum declaration) for analog input 2 (P0756[1] = 4).

Details:

See P0757 to P0760 (ADC scaling).

P0757[2]	Value x1 of ADC scaling [V / mA]	Min: -20	Level 2	
	CStat: CUT	Datatype: Float		Unit: -
	P-Group: TERMINAL	Active: first confirm		QuickComm.: No
		Def: 0		
		Max: 20		

Parameters P0757 - P0760 configure the input scaling as shown in the diagram:

P0756 = 0 ... 3, P0761 = 0

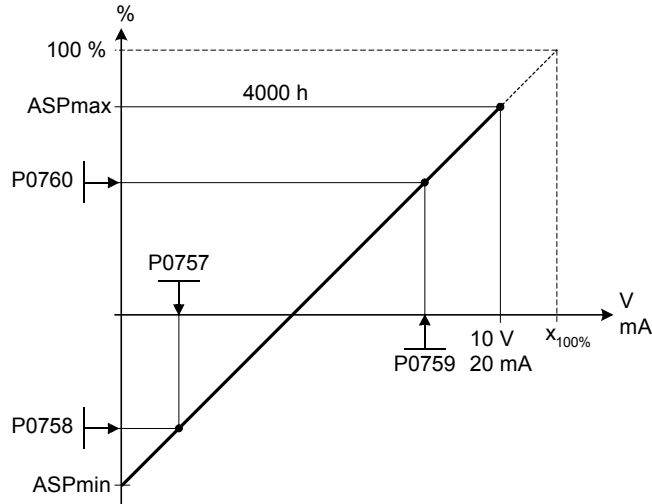

Where:

- Analog setpoints represent a [%] of the normalized frequency in P2000.
- Analog setpoints may be larger than 100 %.
- ASPmax represents highest analog setpoint (this may be at 10 V or 20 mA).
- ASPmin represents lowest analog setpoint (this may be at 0 V or 20 mA).
- Default values provide a scaling of 0 V or 0 mA = 0 %, and 10 V or 20 mA = 100 %.

P0756 = 4, P0761 = 0

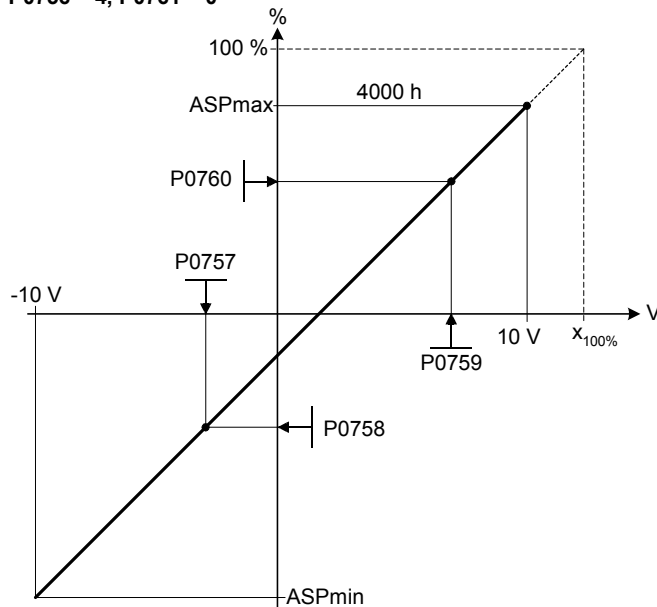

Index:

- P0757[0] : Analog input 1 (ADC 1)
- P0757[1] : Analog input 2 (ADC 2)

Note:

The ADC-linear characteristic is described by 4 coordinates, based on a two-point equation:

$$\frac{y - P0758}{x - P0757} = \frac{P0760 - P0758}{P0759 - P0757}$$

For calculations the point-gradient form (offset and gradient) is more advantageous:

$$y = m \cdot x + y_0$$

The transformation between these two forms is given by:

$$m = \frac{P0760 - P0758}{P0759 - P0757} \quad y_0 = \frac{P0758 \cdot P0759 - P0757 \cdot P0760}{P0759 - P0757}$$

For scaling of the input the value of y_max and x_min has to be determined. This is done by the following equations:

$$x_{min} = \frac{P0760 \cdot P0757 - P0758 \cdot P0759}{P0760 - P0758}$$

$$y_{max} = (x_{max} - x_{min}) \cdot \frac{P0760 - P0758}{P0759 - P0757}$$

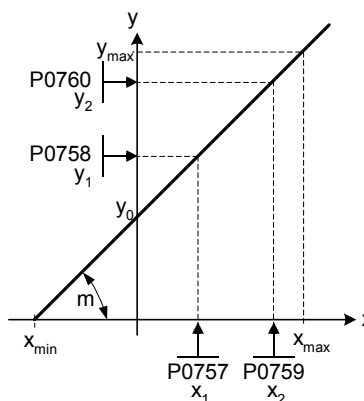

Notice:

The value x2 of ADC scaling P0759 must be greater than the value x1 of ADC scaling P0757.

P0758[2]	Value y1 of ADC scaling	Min: -99999.9	Level 2	
	CStat: CUT	Datatype: Float		Unit: %
	P-Group: TERMINAL	Active: first confirm		QuickComm.: No
		Def: 0.0		
		Max: 99999.9		

Sets value of Y1 in [%] as described in P0757 (ADC scaling)

Index:

- P0758[0] : Analog input 1 (ADC 1)
- P0758[1] : Analog input 2 (ADC 2)

Dependency:

Affects P2000 to P2003 (reference frequency, voltage, current or torque) depending on which setpoint is to be generated.

P0759[2]	Value x2 of ADC scaling [V / mA]	Min: -20	Level 2	
	CStat: CUT	Datatype: Float		Unit: -
	P-Group: TERMINAL	Active: first confirm		QuickComm.: No
		Def: 10		
		Max: 20		

Sets value of X2 as described in P0757 (ADC scaling).

Index:

- P0759[0] : Analog input 1 (ADC 1)
- P0759[1] : Analog input 2 (ADC 2)

Notice:

The value x2 of ADC scaling P0759 must be greater than the value x1 of ADC scaling P0757.

P0760[2]	Value y2 of ADC scaling	Min: -99999.9	Level 2	
	CStat: CUT	Datatype: Float		Unit: %
	P-Group: TERMINAL	Active: first confirm		QuickComm.: No
		Def: 100.0		
		Max: 99999.9		

Sets value of Y2 in [%] as described in P0757 (ADC scaling).

Index:

- P0760[0] : Analog input 1 (ADC 1)
- P0760[1] : Analog input 2 (ADC 2)

Dependency:

Affects P2000 to P2003 (reference frequency, voltage, current or torque) depending on which setpoint is to be generated.

ADC value -10 to +10 V (-50 to +50 Hz):
 The below example produces a -10 to +10 V analog input (-50 to +50 Hz) with center zero and a "holding point" 0.2 V wide (0.1 V to each side of center).

P0756 = 4 and P0761 > 0 and P0758 < 0 < P0760

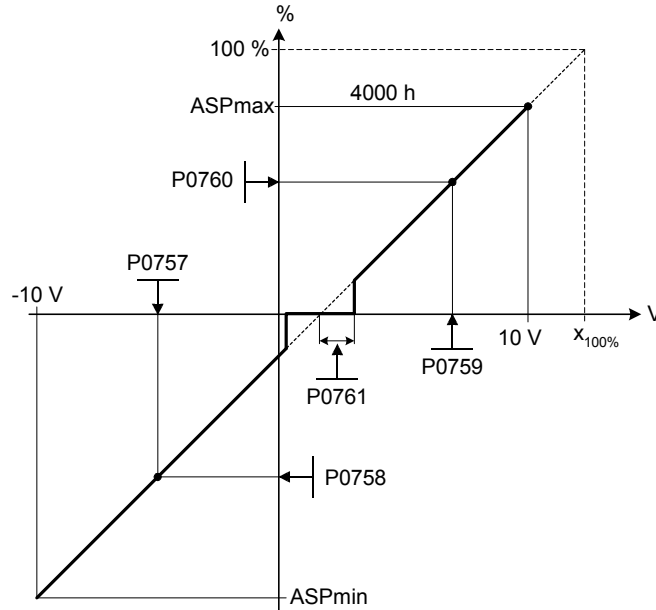

Note:

P0761[x] = 0 : No deadband active.

Deadband starts from 0 V to value of P0761, if both values of P0758 and P0760 (y coordinates of ADC scaling) are positive or negative respectively. However, deadband is active in both directions from point of intersection (x axis with ADC scaling curve), if sign of P0758 and P0760 are opposite.

Min. frequency P1080 should be zero when using center zero setup. There is no hysteresis at the end of the deadband.

P0762[2]	Delay for loss of signal action	Min: 0	Level 3	
	CStat: CUT	Datatype: U16		Unit: ms
	P-Group: TERMINAL	Active: Immediately		QuickComm.: No

Defines time delay between loss of analog setpoint and appearance of fault code F0080.

Index:

- P0762[0] : Analog input 1 (ADC 1)
- P0762[1] : Analog input 2 (ADC 2)

Note:

Expert users can choose the desired reaction to F0080 (default is OFF2).

3.12 Analog outputs

r0770	Number of DACs	Datatype: U16	Unit: -	Min: - Def: - Max: -	Level 3
	P-Group: TERMINAL				

Displays number of analog outputs available.

P0771[2]	CI: DAC	Datatype: U32	Unit: -	Min: 0:0 Def: 21:0 Max: 4000:0	Level 2
	CStat: CUT P-Group: TERMINAL	Active: first confirm	QuickComm.: No		

Defines function of the 0 - 20 mA analog output.

Index:

- P0771[0] : Analog output 1 (DAC 1)
- P0771[1] : Analog output 2 (DAC 2)

Common Settings:

- 21 CO: Act. frequency (scaled to P2000)
- 24 CO: Act. output frequency (scaled to P2000)
- 25 CO: Act. output voltage (scaled to P2001)
- 26 CO: Act. DC-link voltage (scaled to P2001)
- 27 CO: Act. output current (scaled to P2002)

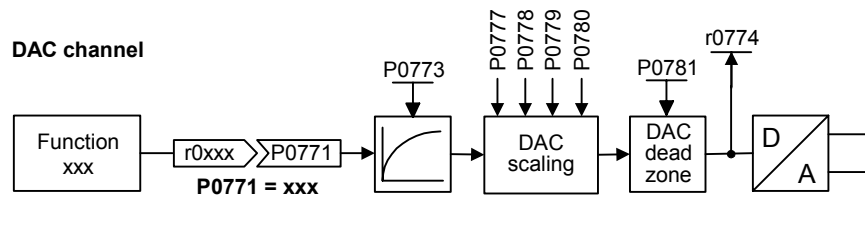

P0773[2]	Smooth time DAC	Datatype: U16	Unit: ms	Min: 0 Def: 2 Max: 1000	Level 3
	CStat: CUT P-Group: TERMINAL	Active: first confirm	QuickComm.: No		

Defines smoothing time [ms] for analog output signal. This parameter enables smoothing for DAC using a PT1 filter.

Index:

- P0773[0] : Analog output 1 (DAC 1)
- P0773[1] : Analog output 2 (DAC 2)

Dependency:

P0773 = 0: Deactivates filter.

r0774[2]	Act. DAC value [mA]	Datatype: Float	Unit: -	Min: - Def: - Max: -	Level 3
	P-Group: TERMINAL				

Shows value of analog output in [mA] after filtering and scaling.

Index:

- r0774[0] : Analog output 1 (DAC 1)
- r0774[1] : Analog output 2 (DAC 2)

P0776[2]	Type of DAC	Datatype: U16	Unit: -	Min: 0 Def: 0 Max: 1	Level 2
	CStat: CT P-Group: TERMINAL	Active: first confirm	QuickComm.: No		

Defines type of analog output.

Possible Settings:

- 0 Current output
- 1 Voltage output

Index:

- P0776[0] : Analog output 1 (DAC 1)
- P0776[1] : Analog output 2 (DAC 2)

Note:

The analog output is designed as a current output with a range of 0...20 mA.

For a voltage output with a range of 0...10 V an external resistor of 500 Ohms has to be connected at the terminals (12/13 or 26/27).

P0777[2]	Value x1 of DAC scaling	Datatype: Float	Unit: %	Min: -99999.0	Level 2
	CStat: CUT	Active: first confirm	QuickComm.: No	Def: 0.0	
	P-Group: TERMINAL			Max: 99999.0	

Defines x1 output characteristic in [%]. Scaling block is responsible for adjustment of output value defined in P0771 (DAC connector input).

Parameters of DAC scaling block (P0777 ... P0781) work as follows:

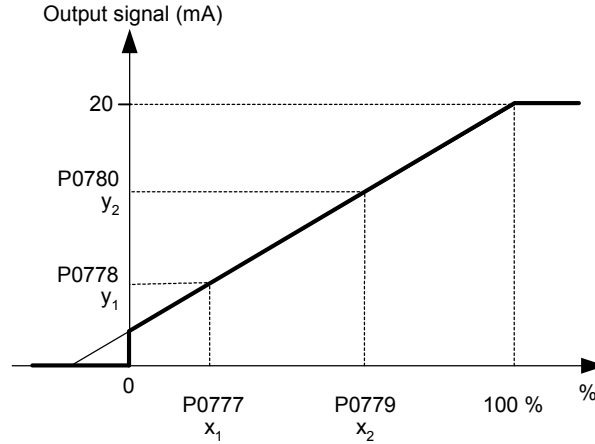

Where:
Points P1 (x1, y1) and P2 (x2, y2) can be chosen freely.

Index:
P0777[0] : Analog output 1 (DAC 1)
P0777[1] : Analog output 2 (DAC 2)

Example:
The default values of the scaling block provides a scaling of:
P1: 0.0 % = 0 mA
P2: 100.0 % = 20 mA

Dependency:
Affects P2000 to P2003 (referency frequency, voltage, current or torque) depending on which setpoint is to be generated.

Note:
The DAC-linear characteristic is described by 4 coordinates, based on a two-point equation:

$$\frac{y - P0778}{x - P0777} = \frac{P0780 - P0778}{P0779 - P0777}$$

For calculations the point-gradient form (offset and gradient) is more advantageous:

$$y = m \cdot x + y_0$$

The transformation between these two forms is given by:

$$m = \frac{P0780 - P0778}{P0779 - P0777} \quad y_0 = \frac{P0778 \cdot P0779 - P0777 \cdot P0780}{P0779 - P0777} \leq |200\%|$$

For scaling of the input the value of y_max and x_min has to be determined. This is done by the following equations:

$$x_{min} = \frac{P0780 \cdot P0777 - P0778 \cdot P0779}{P0780 - P0778}$$

$$y_{max} = (x_{max} - x_{min}) \cdot \frac{P0780 - P0778}{P0779 - P0777}$$

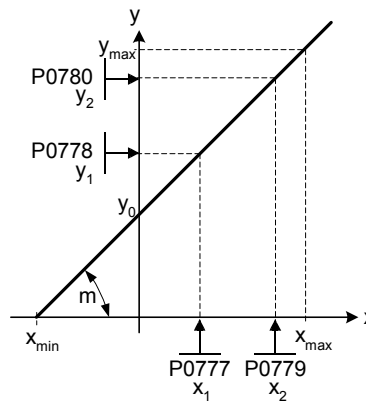

P0778[2]	Value y1 of DAC scaling	Min: 0	Level
	CStat: CUT Datatype: Float Unit: - Def: 0		2
	P-Group: TERMINAL Active: first confirm QuickComm.: No Max: 20		

Defines y1 of output characteristic.

Index:

P0778[0] : Analog output 1 (DAC 1)
 P0778[1] : Analog output 2 (DAC 2)

P0779[2]	Value x2 of DAC scaling	Min: -99999.0	Level
	CStat: CUT Datatype: Float Unit: % Def: 100.0		2
	P-Group: TERMINAL Active: first confirm QuickComm.: No Max: 99999.0		

Defines x2 of output characteristic in [%].

Index:

P0779[0] : Analog output 1 (DAC 1)
 P0779[1] : Analog output 2 (DAC 2)

Dependency:

Affects P2000 to P2003 (referency frequency, voltage, current or torque) depending on which setpoint is to be generated.

P0780[2]	Value y2 of DAC scaling	Min: 0	Level
	CStat: CUT Datatype: Float Unit: - Def: 20		2
	P-Group: TERMINAL Active: first confirm QuickComm.: No Max: 20		

Defines y2 of output characteristic.

Index:

P0780[0] : Analog output 1 (DAC 1)
 P0780[1] : Analog output 2 (DAC 2)

P0781[2]	Width of DAC deadband	Min: 0	Level
	CStat: CUT Datatype: Float Unit: - Def: 0		3
	P-Group: TERMINAL Active: first confirm QuickComm.: No Max: 20		

Sets width of dead-band in [mA] for analog output.

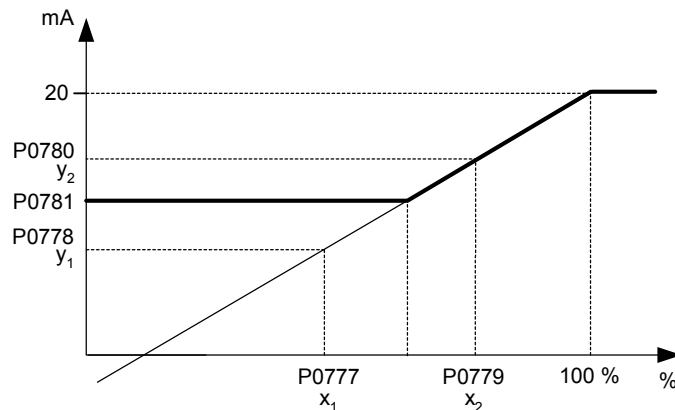

Index:

P0781[0] : Analog output 1 (DAC 1)
 P0781[1] : Analog output 2 (DAC 2)

3.13 Parameter / command / drive data set

P0800[3]	BI: Download parameter set 0	Min: 0:0	Level 3	
	CStat: CT	Datatype: U32		Unit: -
	P-Group: COMMANDS	Active: first confirm		QuickComm.: No
		Def: 0:0		
		Max: 4000:0		

Defines source of command to start download of parameter set 0 from attached AOP.

Index:

- P0800[0] : 1st. Command data set (CDS)
- P0800[1] : 2nd. Command data set (CDS)
- P0800[2] : 3rd. Command data set (CDS)

Common Settings:

- 722.0 = Digital input 1 (requires P0701 to be set to 99, BICO)
- 722.1 = Digital input 2 (requires P0702 to be set to 99, BICO)
- 722.2 = Digital input 3 (requires P0703 to be set to 99, BICO)
- 722.3 = Digital input 4 (requires P0704 to be set to 99, BICO)
- 722.4 = Digital input 5 (requires P0705 to be set to 99, BICO)
- 722.5 = Digital input 6 (requires P0706 to be set to 99, BICO)

Dependency:

1. The parameter set 0 can only be downloaded in conjunction with the AOP
2. Establish communications between the frequency inverter and AOP
3. The frequency inverter must be selected using the AOP if the AOP is connected at the COM link interface (RS485)
4. Select the frequency inverter state "Ready" (r0002 = 1)
5. Signal from P0800:
 - 0 = Do not download.
 - 1 = Start to download parameter set 0 from the AOP.

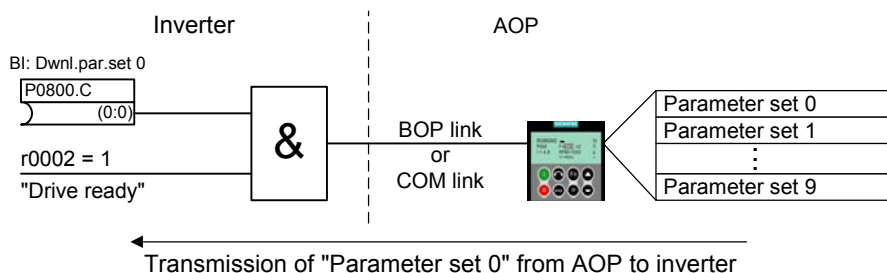

P0801[3]	BI: Download parameter set 1	Min: 0:0	Level 3	
	CStat: CT	Datatype: U32		Unit: -
	P-Group: COMMANDS	Active: first confirm		QuickComm.: No
		Def: 0:0		
		Max: 4000:0		

Defines sources of command to start download of parameter set 1 from attached AOP.

Index:

- P0801[0] : 1st. Command data set (CDS)
- P0801[1] : 2nd. Command data set (CDS)
- P0801[2] : 3rd. Command data set (CDS)

Common Settings:

- 722.0 = Digital input 1 (requires P0701 to be set to 99, BICO)
- 722.1 = Digital input 2 (requires P0702 to be set to 99, BICO)
- 722.2 = Digital input 3 (requires P0703 to be set to 99, BICO)
- 722.3 = Digital input 4 (requires P0704 to be set to 99, BICO)
- 722.4 = Digital input 5 (requires P0705 to be set to 99, BICO)
- 722.5 = Digital input 6 (requires P0706 to be set to 99, BICO)

Note:

See parameter P0800

P0809[3]	Copy command data set (CDS)				Min: 0	Level 3
	CStat: CT	Datatype: U16	Unit: -	Def: 0		
	P-Group: COMMANDS	Active: first confirm	QuickComm.: No	Max: 2		

Calls 'Copy Command Data Set (CDS)' function.

The list of all Command Data Sets (CDS) are shown in the opening instructions of the Parameter List (PLI).

Index:

- P0809[0] : Copy from CDS
- P0809[1] : Copy to CDS
- P0809[2] : Start copy

Example:

Copying of all values from CDS1 to CDS3 can be accomplished by the following procedure:

- P0809[0] = 0 1. CDS
- P0809[1] = 2 3. CDS
- P0809[2] = 1 Start copy

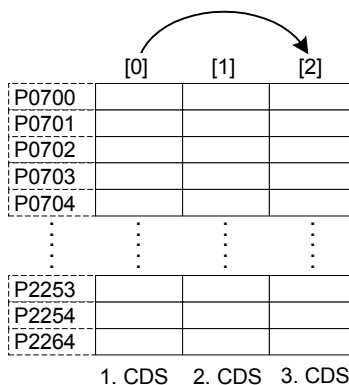

Note:

Start value in index 2 is automatically reset to '0' after execution of function.

P0810	BI: CDS bit 0 (Local / Remote)	Min: 0:0	Level 3	
	CStat: CUT	Datatype: U32		Def: 718:0
	P-Group: COMMANDS	Active: first confirm		Unit: - QuickComm.: No

Selects command source from which to read Bit 0 for selecting a command data set (CDS).

Selecting CDS

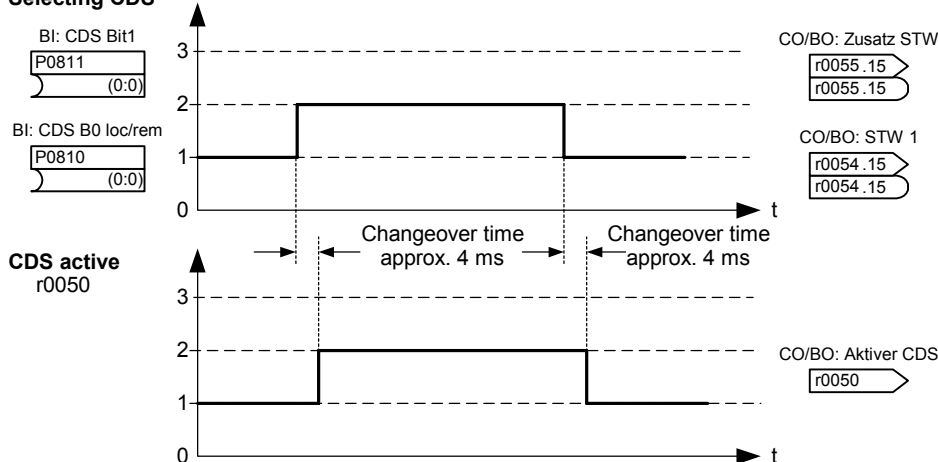

The actual active command data set (CDS) is displayed in parameter r0050.

	selected CDS		active CDS
	r0055 Bit15	r0054 Bit15	r0050
1. CDS	0	0	0
2. CDS	0	1	1
3. CDS	1	0	2
3. CDS	1	1	2

Common Settings:

- 722.0 = Digital input 1 (requires P0701 to be set to 99, BICO)
- 722.1 = Digital input 2 (requires P0702 to be set to 99, BICO)
- 722.2 = Digital input 3 (requires P0703 to be set to 99, BICO)
- 722.3 = Digital input 4 (requires P0704 to be set to 99, BICO)
- 722.4 = Digital input 5 (requires P0705 to be set to 99, BICO)
- 722.5 = Digital input 6 (requires P0706 to be set to 99, BICO)
- 722.6 = Digital input 7 (via analog input 1, requires P0707 to be set to 99)
- 722.7 = Digital input 8 (via analog input 2, requires P0708 to be set to 99)

Example:

Typical procedure for CDS switch-over:

- CDS1: Command source via terminal and setpoint source via analog input (ADC)
- CDS2: Command source via BOP and setpoint source via MOP
- CDS switch-over takes place via digital input 4 (DIN 4)

Steps:

1. Commissioning of inverter / drive
2. CDS1 set parameters (P0700[0] = 2 and P1000[0] = 2)
3. Connect P0810 (P0811 if necessary) with the source of CDS switch-over (P0704[0] = 99, P0810 = 722.3)
4. Copy CDS1 to CDS2 (P0809[0] = 0, P0809[1] = 1, P0809[2] = 2)
5. Change CDS2 parameter as required (set parameters for CDS2 [P0700=1 and P1000=1])

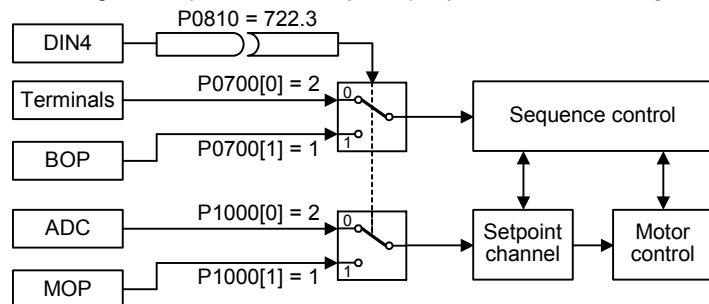

Note:

P0811 is also relevant for command data set (CDS) set selection.

P0811	BI: CDS bit 1			Min: 0:0	Level 2
	CStat: CUT	Datatype: U32	Unit: -	Def: 0:0	
	P-Group: COMMANDS	Active: first confirm	QuickComm.: No	Max: 4095:0	

Selects command source from which to read Bit 1 for selecting a command data set (see P0810).

Common Settings:

- 722.0 = Digital input 1 (requires P0701 to be set to 99, BICO)
- 722.1 = Digital input 2 (requires P0702 to be set to 99, BICO)
- 722.2 = Digital input 3 (requires P0703 to be set to 99, BICO)
- 722.3 = Digital input 4 (requires P0704 to be set to 99, BICO)
- 722.4 = Digital input 5 (requires P0705 to be set to 99, BICO)
- 722.5 = Digital input 6 (requires P0706 to be set to 99, BICO)
- 722.6 = Digital input 7 (via analog input 1, requires P0707 to be set to 99)
- 722.7 = Digital input 8 (via analog input 2, requires P0708 to be set to 99)

Note:

P0810 is also relevant for command data set (CDS) selection.

P0819[3]	Copy drive data set (DDS)			Min: 0	Level 2
	CStat: CT	Datatype: U16	Unit: -	Def: 0	
	P-Group: COMMANDS	Active: first confirm	QuickComm.: No	Max: 2	

Calls 'Copy Drive Data Set (DDS)' function.

The list of all Drive Data Sets (DDS) are shown in the opening instructions of the Parameter List (PLI).

Index:

- P0819[0] : Copy from DDS
- P0819[1] : Copy to DDS
- P0819[2] : Start copy

Example:

Copying of all values from DDS1 to DDS3 can be accomplished by the following procedure:

- P0819[0] = 0 1. DDS
- P0819[1] = 2 3. DDS
- P0819[2] = 1 Start copy

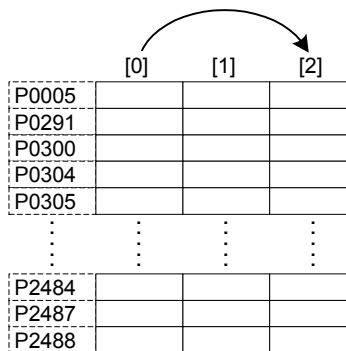

1. DDS 2. DDS 3. DDS

Note:

Start value in index 2 is automatically reset to '0' after execution of function.

P0820	BI: DDS bit 0	Datatype: U32	Unit: -	Min: 0:0	Level 3
	CStat: CT	Active: first confirm	QuickComm.: No	Def: 0:0	
	P-Group: COMMANDS			Max: 4095:0	

Selects command source from which to read Bit 0 for selecting a drive data set (DDS).

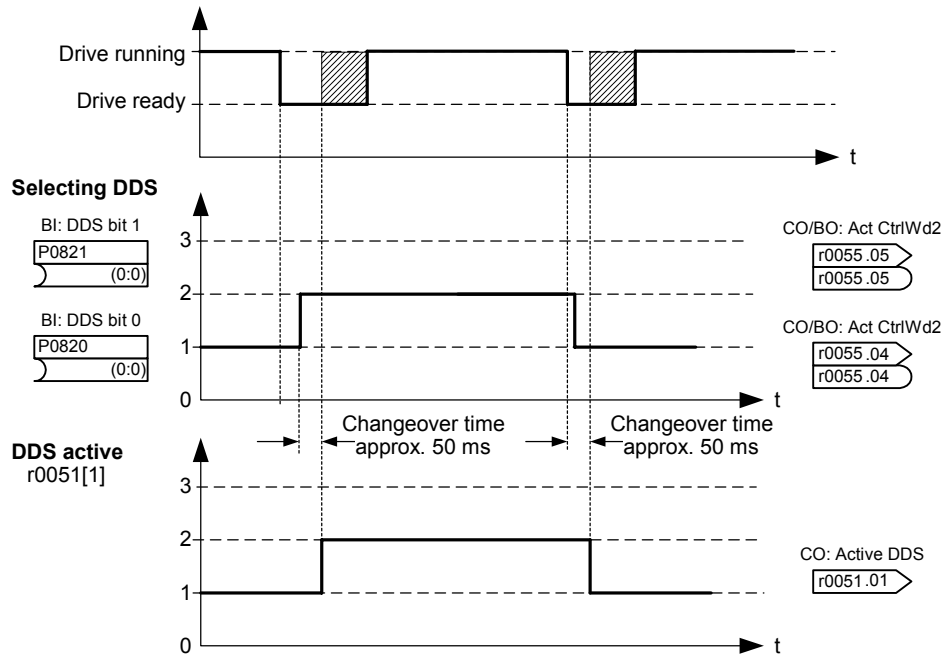

The actual active drive data set (DDS) is displayed in parameter r0051[1].

	selected DDS			active DDS
	r0055 Bit05	r0054 Bit04	r0051 [0]	r0051 [1]
1. DDS	0	0	0	0
2. DDS	0	1	1	1
3. DDS	1	0	2	2
3. DDS	1	1	2	2

Common Settings:

- 722.0 = Digital input 1 (requires P0701 to be set to 99, BICO)
- 722.1 = Digital input 2 (requires P0702 to be set to 99, BICO)
- 722.2 = Digital input 3 (requires P0703 to be set to 99, BICO)
- 722.3 = Digital input 4 (requires P0704 to be set to 99, BICO)
- 722.4 = Digital input 5 (requires P0705 to be set to 99, BICO)
- 722.5 = Digital input 6 (requires P0706 to be set to 99, BICO)
- 722.6 = Digital input 7 (via analog input 1, requires P0707 to be set to 99)
- 722.7 = Digital input 8 (via analog input 2, requires P0708 to be set to 99)

Example:

- a) Commissioning procedure with one motor:
 - Apply commissioning to DDS1
 - Connect P0820 (P0821 if necessary) with DDS source (i.e. via DIN 4: P0704[0] = 99, P0820 = 722.3)
 - Copy DDS1 to DDS2 (P0819[0] = 0, P0819[1] = 1, P0819[2] = 2)
 - Adapt DDS2 parameters (e.g. Ramp-up time P1120[1] and Ramp-down time P1121[1])

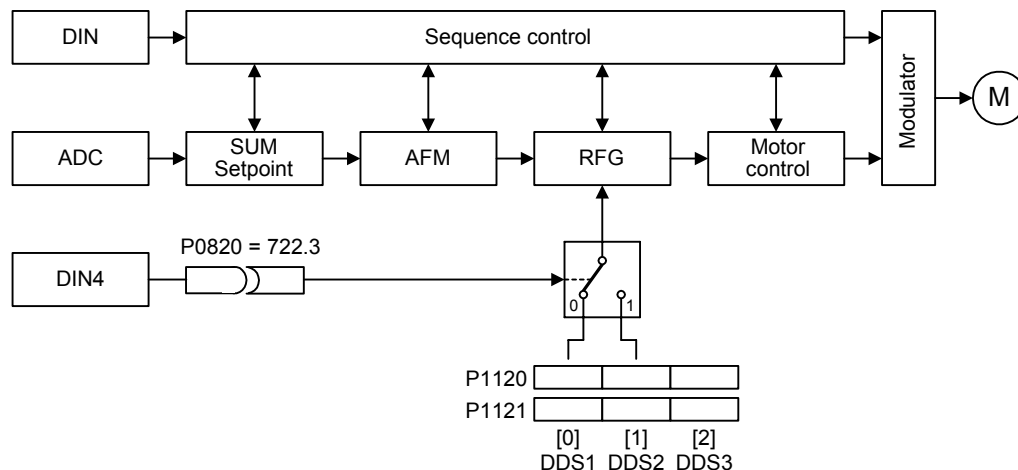

- b) Commissioning procedure with two motors (Motor 1, Motor 2):
- Commission Motor 1; Adapt all other DDS1 parameters (as required)
 - Connect P0820 (P0821 if necessary) with DDS source (i.e. via DIN 4: P0704[0] = 99, P0820 = 722.3)
 - Switch-over to DDS2 (check it via r0051)
 - Commission Motor 2; Adapt all other DDS2 parameters (as required)

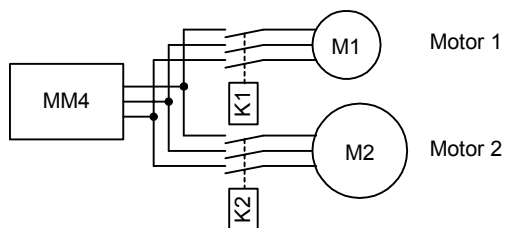

Note:

P0821 is also relevant for drive data set (DDS) selection.

P0821	BI: DDS bit 1	Datatype: U32	Unit: -	Min: 0:0	Level 3
	CStat: CT	Active: first confirm	QuickComm.: No	Def: 0:0	
	P-Group: COMMANDS			Max: 4095:0	

Selects command source from which Bit 1 for selecting a drive data set is to be read in (see parameter P0820).

Common Settings:

- 722.0 = Digital input 1 (requires P0701 to be set to 99, BICO)
- 722.1 = Digital input 2 (requires P0702 to be set to 99, BICO)
- 722.2 = Digital input 3 (requires P0703 to be set to 99, BICO)
- 722.3 = Digital input 4 (requires P0704 to be set to 99, BICO)
- 722.4 = Digital input 5 (requires P0705 to be set to 99, BICO)
- 722.5 = Digital input 6 (requires P0706 to be set to 99, BICO)
- 722.6 = Digital input 7 (via analog input 1, requires P0707 to be set to 99)
- 722.7 = Digital input 8 (via analog input 2, requires P0708 to be set to 99)

Note:

P0820 is also relevant for drive data set (DDS) selection.

3.14 BICO command parameters

P0840[3]	BI: ON/OFF1			Min: 0:0	Level 3
	CStat: CT	Datatype: U32	Unit: -	Def: 722:0	
	P-Group: COMMANDS	Active: first confirm	QuickComm.: No	Max: 4000:0	

Allows ON/OFF1 command source to be selected using BICO.

The first three digits describe the parameter number of the command source; the last digit denotes the bit setting for that parameter. The default setting (ON right) is digital input 1 (722.0). Alternative source possible only when function of digital input 1 is changed (via P0701) before changing value of P0840.

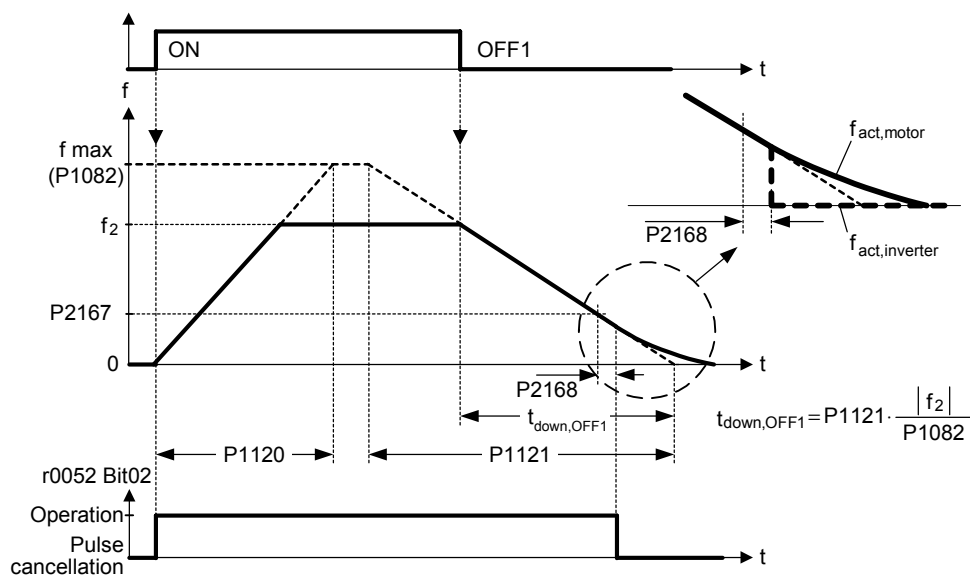

Index:

- P0840[0] : 1st. Command data set (CDS)
- P0840[1] : 2nd. Command data set (CDS)
- P0840[2] : 3rd. Command data set (CDS)

Common Settings:

- 722.0 = Digital input 1 (requires P0701 to be set to 99, BICO)
- 722.1 = Digital input 2 (requires P0702 to be set to 99, BICO)
- 722.2 = Digital input 3 (requires P0703 to be set to 99, BICO)
- 722.3 = Digital input 4 (requires P0704 to be set to 99, BICO)
- 722.4 = Digital input 5 (requires P0705 to be set to 99, BICO)
- 722.5 = Digital input 6 (requires P0706 to be set to 99, BICO)
- 722.6 = Digital input 7 (via analog input 1, requires P0707 to be set to 99)
- 722.7 = Digital input 8 (via analog input 2, requires P0708 to be set to 99)
- 19.0 = ON/OFF1 via BOP

Dependency:

Active only when P0719 < 10. See parameter P0719 (Selection of command/setpoint source).

Note:

- OFF1 means a ramp stop down to 0 using P1121.
- OFF1 is low active.
- For the priority of all soft commands, the following applies: OFF2, OFF3, OFF1

P0842[3]	BI: ON reverse/OFF1			Min: 0:0	Level 3
	CStat: CT	Datatype: U32	Unit: -	Def: 0:0	
	P-Group: COMMANDS	Active: first confirm	QuickComm.: No	Max: 4000:0	

Allows ON/OFF1 reverse command source to be selected using BICO.

The first three digits describe the parameter number of the command source and the last digit denotes the bit setting for that parameter.

Index:

- P0842[0] : 1st. Command data set (CDS)
- P0842[1] : 2nd. Command data set (CDS)
- P0842[2] : 3rd. Command data set (CDS)

Common Settings:

- 722.0 = Digital input 1 (requires P0701 to be set to 99, BICO)
- 722.1 = Digital input 2 (requires P0702 to be set to 99, BICO)
- 722.2 = Digital input 3 (requires P0703 to be set to 99, BICO)
- 722.3 = Digital input 4 (requires P0704 to be set to 99, BICO)
- 722.4 = Digital input 5 (requires P0705 to be set to 99, BICO)
- 722.5 = Digital input 6 (requires P0706 to be set to 99, BICO)
- 722.6 = Digital input 7 (via analog input 1, requires P0707 to be set to 99)
- 722.7 = Digital input 8 (via analog input 2, requires P0708 to be set to 99)
- 19.0 = ON/OFF1 via BOP

Details:

See parameter P0840.

P0844[3]	BI: 1. OFF2			Min: 0:0	Level 3
	CStat: CT	Datatype: U32	Unit: -	Def: 1:0	
	P-Group: COMMANDS	Active: first confirm	QuickComm.: No	Max: 4000:0	

Defines first source of OFF2.

The first three digits describe the parameter number of the command source and the last digit denotes the bit setting for that parameter. If one of the digital inputs is selected for OFF2, the inverter will not run unless the digital input is active.

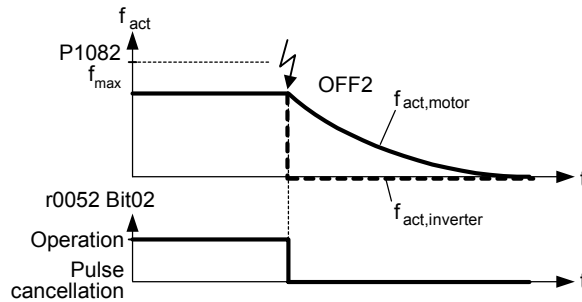

Index:

- P0844[0] : 1st. Command data set (CDS)
- P0844[1] : 2nd. Command data set (CDS)
- P0844[2] : 3rd. Command data set (CDS)

Common Settings:

- 722.0 = Digital input 1 (requires P0701 to be set to 99, BICO)
- 722.1 = Digital input 2 (requires P0702 to be set to 99, BICO)
- 722.2 = Digital input 3 (requires P0703 to be set to 99, BICO)
- 722.3 = Digital input 4 (requires P0704 to be set to 99, BICO)
- 722.4 = Digital input 5 (requires P0705 to be set to 99, BICO)
- 722.5 = Digital input 6 (requires P0706 to be set to 99, BICO)
- 722.6 = Digital input 7 (via analog input 1, requires P0707 to be set to 99)
- 722.7 = Digital input 8 (via analog input 2, requires P0708 to be set to 99)
- 19.0 = ON/OFF1 via BOP
- 19.1 = OFF2: Electrical stop via BOP

Dependency:

Active only when P0719 < 10. See parameter P0719 (Selection of command/setpoint source).

Note:

- OFF2 means an immediate pulse inhibit; the motor coasts down.
- OFF2 is low active.
- The following applies for the priority of all of the OFF commands: OFF2, OFF3, OFF1

P0845[3]	BI: 2. OFF2			Min: 0:0	Level 3
	CStat: CT	Datatype: U32	Unit: -	Def: 19:1	
	P-Group: COMMANDS	Active: first confirm	QuickComm.: No	Max: 4000:0	

Defines second source of OFF2.

The first three digits describe the parameter number of the command source and the last digit denotes the bit setting for that parameter. If one of the digital inputs is selected for OFF2, the inverter will not run unless the digital input is active.

Index:

- P0845[0] : 1st. Command data set (CDS)
- P0845[1] : 2nd. Command data set (CDS)
- P0845[2] : 3rd. Command data set (CDS)

Common Settings:

- 722.0 = Digital input 1 (requires P0701 to be set to 99, BICO)
- 722.1 = Digital input 2 (requires P0702 to be set to 99, BICO)
- 722.2 = Digital input 3 (requires P0703 to be set to 99, BICO)
- 722.3 = Digital input 4 (requires P0704 to be set to 99, BICO)
- 722.4 = Digital input 5 (requires P0705 to be set to 99, BICO)
- 722.5 = Digital input 6 (requires P0706 to be set to 99, BICO)
- 722.6 = Digital input 7 (via analog input 1, requires P0707 to be set to 99)
- 722.7 = Digital input 8 (via analog input 2, requires P0708 to be set to 99)
- 19.0 = ON/OFF1 via BOP

Details:

See parameter P0844.

P0848[3]	BI: 1. OFF3			Min: 0:0	Level 3
	CStat: CT	Datatype: U32	Unit: -	Def: 1:0	
	P-Group: COMMANDS	Active: first confirm	QuickComm.: No	Max: 4000:0	

Defines first source of OFF3.

The first three digits describe the parameter number of the command source and the last digit denotes the bit setting for that parameter. If one of the digital inputs is selected for OFF3, the inverter will not run unless the digital input is active.

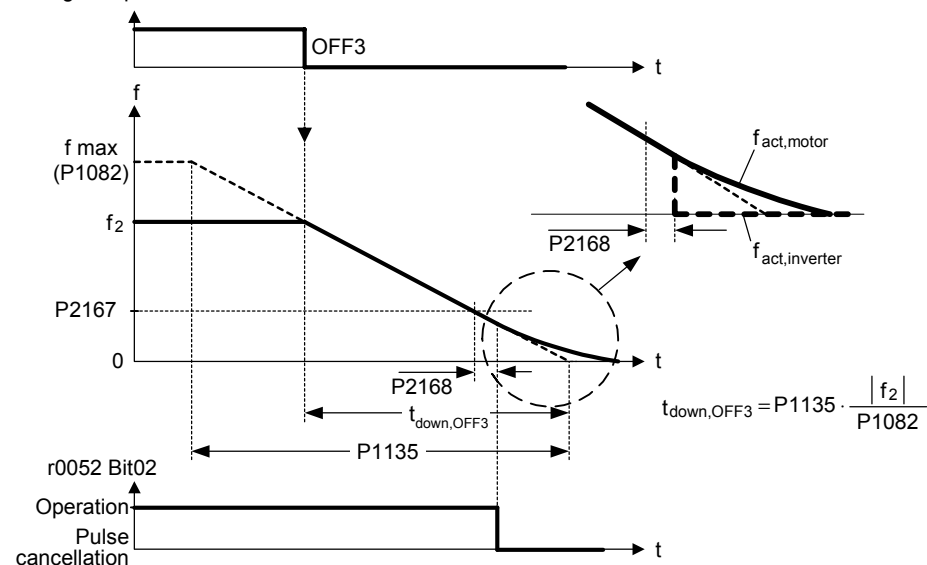

Index:

- P0848[0] : 1st. Command data set (CDS)
- P0848[1] : 2nd. Command data set (CDS)
- P0848[2] : 3rd. Command data set (CDS)

Common Settings:

- 722.0 = Digital input 1 (requires P0701 to be set to 99, BICO)
- 722.1 = Digital input 2 (requires P0702 to be set to 99, BICO)
- 722.2 = Digital input 3 (requires P0703 to be set to 99, BICO)
- 722.3 = Digital input 4 (requires P0704 to be set to 99, BICO)
- 722.4 = Digital input 5 (requires P0705 to be set to 99, BICO)
- 722.5 = Digital input 6 (requires P0706 to be set to 99, BICO)
- 722.6 = Digital input 7 (via analog input 1, requires P0707 to be set to 99)
- 722.7 = Digital input 8 (via analog input 2, requires P0708 to be set to 99)
- 19.0 = ON/OFF1 via BOP

Dependency:

Active only when P0719 < 10. See parameter P0719 (Selection of command/setpoint source).

Note:

- OFF3 means fast ramp-down to 0 Hz through P1135.
- OFF3 is low-active.
- Priority of all OFF commands: OFF2, OFF3, OFF1

P0849[3]	BI: 2. OFF3			Min: 0:0	Level 3
	CStat: CT	Datatype: U32	Unit: -	Def: 1:0	
	P-Group: COMMANDS	Active: first confirm	QuickComm.: No	Max: 4000:0	

Defines second source of OFF3.

The first three digits describe the parameter number of the command source and the last digit denotes the bit setting for that parameter. If one of the digital inputs is selected for OFF3, the inverter will not run unless the digital input is active.

Index:

P0849[0] : 1st. Command data set (CDS)
P0849[1] : 2nd. Command data set (CDS)
P0849[2] : 3rd. Command data set (CDS)

Common Settings:

722.0 = Digital input 1 (requires P0701 to be set to 99, BICO)
722.1 = Digital input 2 (requires P0702 to be set to 99, BICO)
722.2 = Digital input 3 (requires P0703 to be set to 99, BICO)
722.3 = Digital input 4 (requires P0704 to be set to 99, BICO)
722.4 = Digital input 5 (requires P0705 to be set to 99, BICO)
722.5 = Digital input 6 (requires P0706 to be set to 99, BICO)
722.6 = Digital input 7 (via analog input 1, requires P0707 to be set to 99)
722.7 = Digital input 8 (via analog input 2, requires P0708 to be set to 99)
19.0 = ON/OFF1 via BOP

Dependency:

In contrast to P0848 (first source of OFF3), this parameter is always active, independent of P0719 (selection of command and frequency setpoint).

Details:

See parameter P0848.

P0852[3]	BI: Pulse enable			Min: 0:0	Level 3
	CStat: CT	Datatype: U32	Unit: -	Def: 1:0	
	P-Group: COMMANDS	Active: first confirm	QuickComm.: No	Max: 4000:0	

Defines source of pulse enable/disable signal.

Index:

P0852[0] : 1st. Command data set (CDS)
P0852[1] : 2nd. Command data set (CDS)
P0852[2] : 3rd. Command data set (CDS)

Common Settings:

722.0 = Digital input 1 (requires P0701 to be set to 99, BICO)
722.1 = Digital input 2 (requires P0702 to be set to 99, BICO)
722.2 = Digital input 3 (requires P0703 to be set to 99, BICO)
722.3 = Digital input 4 (requires P0704 to be set to 99, BICO)
722.4 = Digital input 5 (requires P0705 to be set to 99, BICO)
722.5 = Digital input 6 (requires P0706 to be set to 99, BICO)
722.6 = Digital input 7 (via analog input 1, requires P0707 to be set to 99)
722.7 = Digital input 8 (via analog input 2, requires P0708 to be set to 99)

Dependency:

Active only when P0719 < 10. See parameter P0719 (Selection of command/setpoint source).

3.15 Communication parameters

P0918	CB address			Min: 0	Level 2
	CStat: CT	Datatype: U16	Unit: -	Def: 3	
	P-Group: COMM	Active: first confirm	QuickComm.: No	Max: 65535	

Defines address of CB (communication board) or address of the other option modules.

There are two ways to set the bus address:

- via DIP switches on the PROFIBUS module
- via a user-entered value

Note:

Possible PROFIBUS settings:

- 1 ... 125
- 0, 126, 127 are not allowed

The following applies when a PROFIBUS module is used:

- DIP switch = 0 Address defined in P0918 (CB address) is valid
- DIP switch not = 0 DIP switch setting has priority and P0918 indicates DIP switch setting.

P0927	Parameter changeable via				Min: 0	Level 3
	CStat: CUT	Datatype: U16	Unit: -	Def: 15		
	P-Group: COMM	Active: first confirm	QuickComm.: No	Max: 15		

Specifies the interfaces which can be used to change parameters.

This parameter allows the user to easily protect the inverter from unauthorized modification of parameters.
Annotation: Parameter P0927 is not password protected.

Bitfields:

Bit00	PROFIBUS / CB	0	NO	1	YES
Bit01	BOP	0	NO	1	YES
Bit02	USS on BOP link	0	NO	1	YES
Bit03	USS on COM link	0	NO	1	YES

Example:

Bits 0, 1, 2 and 3 set:

The default setting allows parameters to be changed via any interface. If all bits are set, the parameter is displayed on BOP as follows:

BOP: 

Bits 0, 1, 2 and 3 reset:

This setting allows no parameters to be modified via any interface with the exception of P0003 and P0927. If all bits are reset, the parameter is displayed on BOP as follows:

BOP: 

Details:

The seven-segment display is explained in the "Introduction to MICROMASTER System Parameters" in this handbook.

r0947[8]	Last fault code				Min: -	Level 3
			Datatype: U16	Unit: -	Def: -	
	P-Group: ALARMS				Max: -	

Displays fault history according to the diagram below

where:

- "F1" is the first active fault (not yet acknowledged).
- "F2" is the second active fault (not yet acknowledged).
- "F1e" is the occurrence of the fault acknowledgement for F1 & F2.

This moves the value in the 2 indices down to the next pair of indices, where they are stored. Indices 0 & 1 contain the active faults. When faults are acknowledged, indices 0 & 1 are reset to 0.

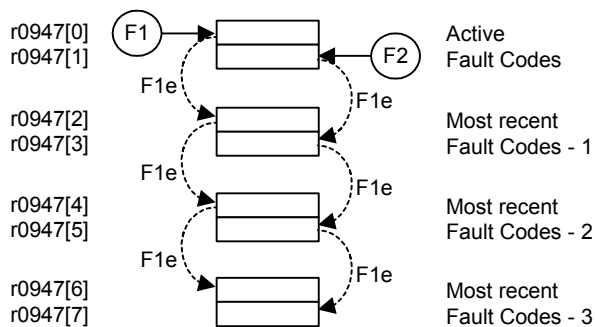

Index:

- r0947[0] : Recent fault trip --, fault 1
- r0947[1] : Recent fault trip --, fault 2
- r0947[2] : Recent fault trip -1, fault 3
- r0947[3] : Recent fault trip -1, fault 4
- r0947[4] : Recent fault trip -2, fault 5
- r0947[5] : Recent fault trip -2, fault 6
- r0947[6] : Recent fault trip -3, fault 7
- r0947[7] : Recent fault trip -3, fault 8

Example:

If the inverter trips on undervoltage and then receives an external trip before the undervoltage is acknowledged, you will obtain:

- r0947[0] = 3 Undervoltage (F0003)
- r0947[1] = 85 External trip (F0085)

Whenever a fault in index 0 is acknowledged (F1e), the fault history shifts as indicated in the diagram above.

Dependency:

Index 1 used only if second fault occurs before first fault is acknowledged.

Details:

See "Faults and Warnings"

r0948[12]	Fault time	Datatype: U16	Unit: -	Min: - Def: - Max: -	Level 3
	P-Group: ALARMS				

Time stamp to indicate when the fault has occurred.

Index:

- r0948[0] : Recent fault trip --, time stamp
- r0948[1] : Recent fault trip --, time stamp
- r0948[2] : Recent fault trip --, time stamp
- r0948[3] : Recent fault trip -1, time stamp
- r0948[4] : Recent fault trip -1, time stamp
- r0948[5] : Recent fault trip -1, time stamp
- r0948[6] : Recent fault trip -2, time stamp
- r0948[7] : Recent fault trip -2, time stamp
- r0948[8] : Recent fault trip -2, time stamp
- r0948[9] : Recent fault trip -3, time stamp
- r0948[10] : Recent fault trip -3, time stamp
- r0948[11] : Recent fault trip -3, time stamp

Details:

Parameter r2114 (runtime counter) is a possible source of the time stamp. When using the runtime counter, the time is entered into the first two indices of the fault trip (shutdown) essentially the same as for r2114.

Time stamp when using r2114 (Refer to parameter r2114):

- r0948[0] : Last fault trip --, system time, seconds, upper word
- r0948[1] : Last fault trip --, system time, seconds, lower word
- r0948[2] : 0
- r0948[3] : Last fault trip --, system time, seconds, upper word
- r0948[4] : Last fault trip --, system time, seconds, lower word
- r0948[5] : 0
- r0948[6] : Last fault trip --, system time, seconds, upper word
- r0948[7] : Last fault trip --, system time, seconds, lower word
- r0948[8] : 0
- r0948[9] : Last fault trip --, system time, seconds, upper word
- r0948[10] : Last fault trip --, system time, seconds, lower word
- r0948[11] : 0

r0949[8]	Fault value	Datatype: U16	Unit: -	Min: - Def: - Max: -	Level 3
	P-Group: ALARMS				

Displays drive fault values. It is for service purposes and indicate the type of fault reported. The values are listed in the code where faults are reported.

Index:

- r0949[0] : Recent fault trip --, fault value 1
- r0949[1] : Recent fault trip --, fault value 2
- r0949[2] : Recent fault trip -1, fault value 3
- r0949[3] : Recent fault trip -1, fault value 4
- r0949[4] : Recent fault trip -2, fault value 5
- r0949[5] : Recent fault trip -2, fault value 6
- r0949[6] : Recent fault trip -3, fault value 7
- r0949[7] : Recent fault trip -3, fault value 8

P0952	Total number of faults	Datatype: U16	Unit: -	Min: 0 Def: 0 Max: 8	Level 3
	CStat: CT	Active: first confirm	QuickComm.: No		
	P-Group: ALARMS				

Displays number of faults stored in r0947 (last fault code).

Dependency:

Setting 0 resets fault history. (changing to 0 also resets parameter r0948 - fault time).

r0964[5]	Firmware version data	Datatype: U16	Unit: -	Min: - Def: - Max: -	Level 3
P-Group: COMM					

Firmware version data.

Index:

r0964[0] : Company (Siemens = 42)
r0964[1] : Product type
r0964[2] : Firmware version
r0964[3] : Firmware date (year)
r0964[4] : Firmware date (day/month)

Example:

No.	Value	Meaning
r0964[0]	42	SIEMENS
r0964[1]	1001	MICROMASTER 420
	1002	MICROMASTER 440
	1003	MICRO- / COMBIMASTER 411
	1004	MICROMASTER 410
	1005	reserved
	1006	MICROMASTER 440 PX
	1007	MICROMASTER 430
r0964[2]	105	Firmware V1.05
r0964[3]	2001	27.10.2001
r0964[4]	2710	

r0965	Profibus profile	Datatype: U16	Unit: -	Min: - Def: - Max: -	Level 3
P-Group: COMM					

Identification for PROFIDrive. Profile number and version.

r0967	Control word 1	Datatype: U16	Unit: -	Min: - Def: - Max: -	Level 3
P-Group: COMM					

Displays control word 1.

Bitfields:

Bit00	ON/OFF1	0	NO	1	YES
Bit01	OFF2: Electrical stop	0	YES	1	NO
Bit02	OFF3: Fast stop	0	YES	1	NO
Bit03	Pulse enable	0	NO	1	YES
Bit04	RFG enable	0	NO	1	YES
Bit05	RFG start	0	NO	1	YES
Bit06	Setpoint enable	0	NO	1	YES
Bit07	Fault acknowledge	0	NO	1	YES
Bit08	JOG right	0	NO	1	YES
Bit09	JOG left	0	NO	1	YES
Bit10	Control from PLC	0	NO	1	YES
Bit11	Reverse (setpoint inversion)	0	NO	1	YES
Bit13	Motor potentiometer MOP up	0	NO	1	YES
Bit14	Motor potentiometer MOP down	0	NO	1	YES
Bit15	CDS Bit 0 (Local/Remote)	0	NO	1	YES

r0968	Status word 1	Datatype: U16	Unit: -	Min: -	Level 3
	P-Group: COMM			Def: - Max: -	

Displays active status word of inverter (in binary) and can be used to diagnose which commands are active.

Bitfields:

Bit00	Drive ready	0	NO	1	YES
Bit01	Drive ready to run	0	NO	1	YES
Bit02	Drive running	0	NO	1	YES
Bit03	Drive fault active	0	NO	1	YES
Bit04	OFF2 active	0	YES	1	NO
Bit05	OFF3 active	0	YES	1	NO
Bit06	ON inhibit active	0	NO	1	YES
Bit07	Drive warning active	0	NO	1	YES
Bit08	Deviation setpoint / act. value	0	YES	1	NO
Bit09	PZD control	0	NO	1	YES
Bit10	Maximum frequency reached	0	NO	1	YES
Bit11	Warning: Motor current limit	0	YES	1	NO
Bit12	Motor holding brake active	0	NO	1	YES
Bit13	Motor overload	0	YES	1	NO
Bit14	Motor runs right	0	NO	1	YES
Bit15	Inverter overload	0	YES	1	NO

P0970	Factory reset	Datatype: U16	Unit: -	Min: 0	Level 1
	CStat: C	Active: first confirm	QuickComm.: No	Def: 0 Max: 1	

P0970 = 1 resets all parameters to their default values.

Possible Settings:

0	Disabled
1	Parameter reset

Dependency:

- First set P0010 = 30 (factory settings).
- Stop drive (i.e. disable all pulses) before you can reset parameters to default values.

Note:

The following parameters retain their values after a factory reset:

- r0039 CO: Energy consumption meter [kWh]
- P0100 Europe / North America
- P0918 CB address
- P2010 USS baud rate
- P2011 USS address

P0971	Transfer data from RAM to EEPROM	Datatype: U16	Unit: -	Min: 0	Level 3
	CStat: CUT	Active: first confirm	QuickComm.: No	Def: 0 Max: 1	

Transfers values from RAM to EEPROM when set to 1.

Possible Settings:

0	Disabled
1	Start transfer

Note:

All values in RAM are transferred to EEPROM.

Parameter is automatically reset to 0 (default) after successful transfer.

The storage from RAM to EEPROM is accomplished via P0971. The communications are reset, if the transfer was successful. During the reset process communications will be interrupted. This creates the following conditions:

- PLC (e.g. SIMATIC S7) enters Stop mode
- Starter automatically recovers communications once they are re-established.
- BOP displays "busy"

After completion of the transfer process, the communication between the inverter and the PC-tools (e.g. Starter) or BOP is automatically re-established.

3.16 Setpoint source

P1000[3]	Selection of frequency setpoint	Min: 0	Level 1	
	CStat: CT	Datatype: U16		Unit: -
	P-Group: SETPOINT	Active: first confirm		QuickComm.: Yes
		Def: 2		
		Max: 77		

Selects frequency setpoint source. In the table of possible settings below, the main setpoint is selected from the least significant digit (i.e., 0 to 7) and any additional setpoint from the most significant digit (i.e., x0 through to x7).

Possible Settings:

- 0 No main setpoint
- 1 MOP setpoint
- 2 Analog setpoint
- 3 Fixed frequency
- 4 USS on BOP link
- 5 USS on COM link
- 6 CB on COM link
- 7 Analog setpoint 2
- 10 No main setpoint + MOP setpoint
- 11 MOP setpoint + MOP setpoint
- 12 Analog setpoint + MOP setpoint
- 13 Fixed frequency + MOP setpoint
- 14 USS on BOP link + MOP setpoint
- 15 USS on COM link + MOP setpoint
- 16 CB on COM link + MOP setpoint
- 17 Analog setpoint 2 + MOP setpoint
- 20 No main setpoint + Analog setpoint
- 21 MOP setpoint + Analog setpoint
- 22 Analog setpoint + Analog setpoint
- 23 Fixed frequency + Analog setpoint
- 24 USS on BOP link + Analog setpoint
- 25 USS on COM link + Analog setpoint
- 26 CB on COM link + Analog setpoint
- 27 Analog setpoint 2 + Analog setpoint
- 30 No main setpoint + Fixed frequency
- 31 MOP setpoint + Fixed frequency
- 32 Analog setpoint + Fixed frequency
- 33 Fixed frequency + Fixed frequency
- 34 USS on BOP link + Fixed frequency
- 35 USS on COM link + Fixed frequency
- 36 CB on COM link + Fixed frequency
- 37 Analog setpoint 2 + Fixed frequency
- 40 No main setpoint + USS on BOP link
- 41 MOP setpoint + USS on BOP link
- 42 Analog setpoint + USS on BOP link
- 43 Fixed frequency + USS on BOP link
- 44 USS on BOP link + USS on BOP link
- 45 USS on COM link + USS on BOP link
- 46 CB on COM link + USS on BOP link
- 47 Analog setpoint 2 + USS on BOP link
- 50 No main setpoint + USS on COM link
- 51 MOP setpoint + USS on COM link
- 52 Analog setpoint + USS on COM link
- 53 Fixed frequency + USS on COM link
- 54 USS on BOP link + USS on COM link
- 55 USS on COM link + USS on COM link
- 57 Analog setpoint 2 + USS on COM link
- 60 No main setpoint + CB on COM link
- 61 MOP setpoint + CB on COM link
- 62 Analog setpoint + CB on COM link
- 63 Fixed frequency + CB on COM link
- 64 USS on BOP link + CB on COM link
- 66 CB on COM link + CB on COM link
- 67 Analog setpoint 2 + CB on COM link
- 70 No main setpoint + Analog setpoint 2
- 71 MOP setpoint + Analog setpoint 2
- 72 Analog setpoint + Analog setpoint 2
- 73 Fixed frequency + Analog setpoint 2
- 74 USS on BOP link + Analog setpoint 2
- 75 USS on COM link + Analog setpoint 2
- 76 CB on COM link + Analog setpoint 2
- 77 Analog setpoint 2 + Analog setpoint 2

Index:

- P1000[0] : 1st. Command data set (CDS)
- P1000[1] : 2nd. Command data set (CDS)
- P1000[2] : 3rd. Command data set (CDS)

Example:

Setting 12 selects main setpoint (2) derived from analog input with additional setpoint (1) taken from the motor potentiometer.

Example P1000 = 12 :

P1000 = 12 ⇒ P1070 = 755	P1070 CI: Main setpoint
	r0755 CO: Act. ADC after scal. [4000h]
P1000 = 12 ⇒ P1075 = 1050	P1075 CI: Additional setpoint
	r1050 CO: Act. Output freq. of the MOP

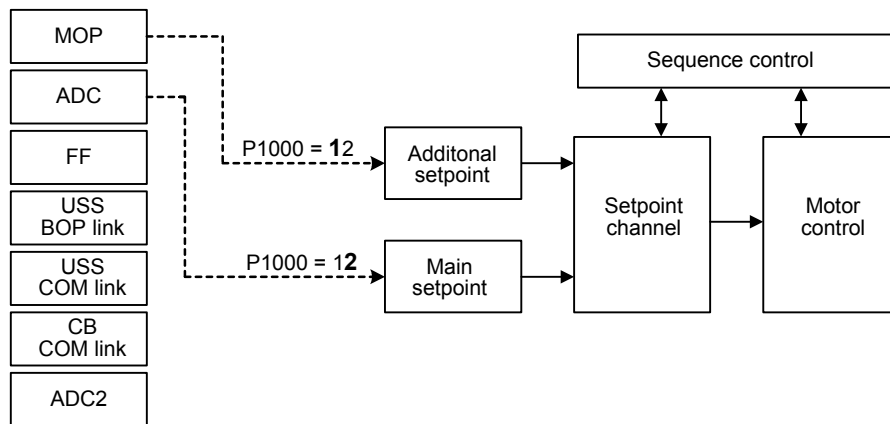

Caution:

Be aware, by changing of parameter P1000 all BICO parameters (see table below) are modified.

Note:

Single digits denote main setpoints that have no additional setpoint.

Changing this parameter sets (to default) all settings on item selected (see table).

		P1000 = xy								
		y = 0	y = 1	y = 2	y = 3	y = 4	y = 5	y = 6	y = 7	
x = 0		0.0	1050.0	755.0	1024.0	2015.1	2018.1	2050.1	755.1	P1070
		1.0	1.0	1.0	1.0	1.0	1.0	1.0	1.0	P1071
		0.0	0.0	0.0	0.0	0.0	0.0	0.0	0.0	P1075
		1.0	1.0	1.0	1.0	1.0	1.0	1.0	1.0	P1076
x = 1		0.0	1050.0	755.0	1024.0	2015.1	2018.1	2050.1	755.1	P1070
		1.0	1.0	1.0	1.0	1.0	1.0	1.0	1.0	P1071
		1050.0	1050.0	1050.0	1050.0	1050.0	1050.0	1050.0	1050.0	P1075
		1.0	1.0	1.0	1.0	1.0	1.0	1.0	1.0	P1076
x = 2		0.0	1050.0	755.0	1024.0	2015.1	2018.1	2050.1	755.1	P1070
		1.0	1.0	1.0	1.0	1.0	1.0	1.0	1.0	P1071
		755.0	755.0	755.0	755.0	755.0	755.0	755.0	755.0	P1075
		1.0	1.0	1.0	1.0	1.0	1.0	1.0	1.0	P1076
x = 3		0.0	1050.0	755.01	1024.0	2015.1	2018.1	2050.1	755.1	P1070
		1.0	1.0	1.0	1.0	1.0	1.0	1.0	1.0	P1071
		1024.0	1024.0	1024.0	1024.0	1024.0	1024.0	1024.0	1024.0	P1075
		1.0	1.0	1.0	1.0	1.0	1.0	1.0	1.0	P1076
x = 4		0.0	1050.0	755.0	1024.0	2015.1	2018.1	2050.1	755.1	P1070
		1.0	1.0	1.0	1.0	1.0	1.0	1.0	1.0	P1071
		2015.1	2015.1	2015.1	2015.1	2015.1	2015.1	2015.1	2015.1	P1075
		1.0	1.0	1.0	1.0	1.0	1.0	1.0	1.0	P1076
x = 5		0.0	1050.0	755.0	1024.0	2015.1	2018.1		755.1	P1070
		1.0	1.0	1.0	1.0	1.0	1.0		1.0	P1071
		2018.1	2018.1	2018.1	2018.1	2018.1	2018.1		2018.1	P1075
		1.0	1.0	1.0	1.0	1.0	1.0		1.0	P1076
x = 6		0.0	1050.0	755.0	1024.0	2015.1		2050.1	755.1	P1070
		1.0	1.0	1.0	1.0	1.0		1.0	1.0	P1071
		2050.1	2050.1	2050.1	2050.1	2050.1		2050.1	2050.1	P1075
		1.0	1.0	1.0	1.0	1.0		1.0	1.0	P1076
x = 7		0.0	1050.0	755.0	1024.0	2015.1	2018.1	2050.1	755.1	P1070
		1.0	1.0	1.0	1.0	1.0	1.0	1.0	1.0	P1071
		755.1	755.1	755.1	755.1	755.1	755.1	755.1	755.1	P1075
		1.0	1.0	1.0	1.0	1.0	1.0	1.0	1.0	P1076

Example:

P1000 = 21 → P1070 = 1050.0
 P1071 = 1.0
 P1075 = 755.0
 P1076 = 1.0

3.17 Fixed frequencies

P1001[3]	Fixed frequency 1			Min: -650.00	Level 3
	CStat: CUT	Datatype: Float	Unit: Hz	Def: 0.00	
	P-Group: SETPOINT	Active: Immediately	QuickComm.: No	Max: 650.00	

Defines fixed frequency setpoint 1.

There are three options available for selection of the fixed frequencies:

1. Direct selection
 2. Direct selection + ON command
 3. Binary coded selection + ON command
1. Direct selection (P0701 - P0706 = 15):
 - In this mode of operation 1 digital input selects 1 fixed frequency.
 - If several inputs are active together, the selected frequencies are summed.
 - E.g.: FF1 + FF2 + FF3 + FF4 + FF5 + FF6.
 2. Direct selection + ON command (P0701 - P0706 = 16):
 - The fixed frequency selection combines the fixed frequencies with an ON command.
 - In this mode of operation 1 digital input selects 1 fixed frequency.
 - If several inputs are active together, the selected frequencies are summed.
 - E.g.: FF1 + FF2 + FF3 + FF4 + FF5 + FF6.
 3. Binary coded selection + ON command (P0701 - P0706 = 17):
 - Up to 16 fixed frequencies can be selected using this method.
 - The fixed frequencies are selected according to the following table:

Index:

P1001[0] : 1st. Drive data set (DDS)
 P1001[1] : 2nd. Drive data set (DDS)
 P1001[2] : 3rd. Drive data set (DDS)

Example:

Binary coded selection :

		DIN4	DIN3	DIN2	DIN1
0 Hz	FF0	0	0	0	0
P1001	FF1	0	0	0	1
P1002	FF2	0	0	1	0
P1003	FF3	0	0	1	1
P1004	FF4	0	1	0	0
P1005	FF5	0	1	0	1
P1006	FF6	0	1	1	0
P1007	FF7	0	1	1	1
P1008	FF8	1	0	0	0
P1009	FF9	1	0	0	1
P1010	FF10	1	0	1	0
P1011	FF11	1	0	1	1
P1012	FF12	1	1	0	0
P1013	FF13	1	1	0	1
P1014	FF14	1	1	1	0
P1015	FF15	1	1	1	1

Direct selection of FF P1001 via DIN 1:
 P0701 = 15 or P0701 = 99, P1020 = 722.0, P1016 = 1
 P0702 = 15 or P0702 = 99, P1021 = 722.1, P1017 = 1

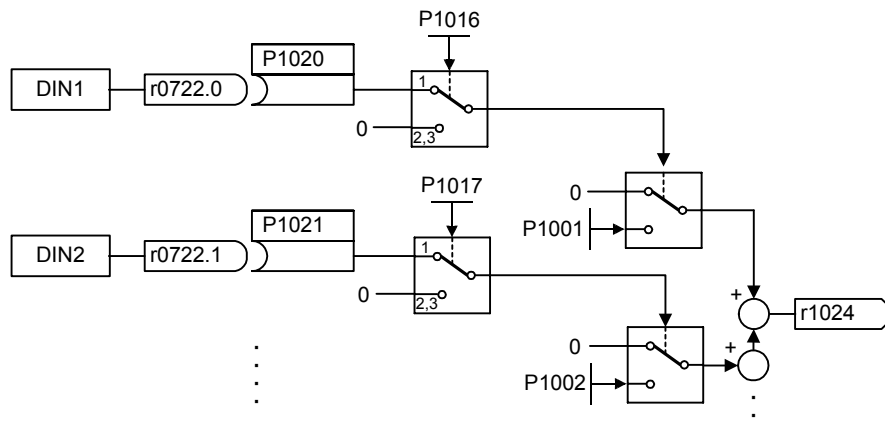

Dependency:

Select fixed frequency operation (using P1000).

Inverter requires ON command to start in the case of direct selection (P0701 - P0706 = 15).

Note:

Fixed frequencies can be selected using the digital inputs, and can also be combined with an ON command.

P1002[3]	Fixed frequency 2	Datatype: Float	Unit: Hz	Min: -650.00	Level 3
	CStat: CUT	Active: Immediately	QuickComm.: No	Def: 5.00	
	P-Group: SETPOINT			Max: 650.00	

Defines fixed frequency setpoint 2.

Index:

- P1002[0] : 1st. Drive data set (DDS)
- P1002[1] : 2nd. Drive data set (DDS)
- P1002[2] : 3rd. Drive data set (DDS)

Details:

See parameter P1001 (fixed frequency 1).

P1003[3]	Fixed frequency 3	Datatype: Float	Unit: Hz	Min: -650.00	Level 3
	CStat: CUT	Active: Immediately	QuickComm.: No	Def: 10.00	
	P-Group: SETPOINT			Max: 650.00	

Defines fixed frequency setpoint 3.

Index:

- P1003[0] : 1st. Drive data set (DDS)
- P1003[1] : 2nd. Drive data set (DDS)
- P1003[2] : 3rd. Drive data set (DDS)

Details:

See parameter P1001 (fixed frequency 1).

P1004[3]	Fixed frequency 4	Datatype: Float	Unit: Hz	Min: -650.00	Level 3
	CStat: CUT	Active: Immediately	QuickComm.: No	Def: 15.00	
	P-Group: SETPOINT			Max: 650.00	

Defines fixed frequency setpoint 4.

Index:

- P1004[0] : 1st. Drive data set (DDS)
- P1004[1] : 2nd. Drive data set (DDS)
- P1004[2] : 3rd. Drive data set (DDS)

Details:

See parameter P1001 (fixed frequency 1).

P1005[3]	Fixed frequency 5	Datatype: Float	Unit: Hz	Min: -650.00	Level 3
	CStat: CUT	Active: Immediately	QuickComm.: No	Def: 20.00	
	P-Group: SETPOINT			Max: 650.00	

Defines fixed frequency setpoint 5.

Index:

- P1005[0] : 1st. Drive data set (DDS)
- P1005[1] : 2nd. Drive data set (DDS)
- P1005[2] : 3rd. Drive data set (DDS)

Details:

See parameter P1001 (fixed frequency 1).

P1006[3]	Fixed frequency 6	Min: -650.00	Level 3
	CStat: CUT Datatype: Float Unit: Hz Def: 25.00	Max: 650.00	
	P-Group: SETPOINT Active: Immediately QuickComm.: No		
	Defines fixed frequency setpoint 6.		
Index:	P1006[0] : 1st. Drive data set (DDS) P1006[1] : 2nd. Drive data set (DDS) P1006[2] : 3rd. Drive data set (DDS)		
Details:	See parameter P1001 (fixed frequency 1).		
P1007[3]	Fixed frequency 7	Min: -650.00	Level 3
	CStat: CUT Datatype: Float Unit: Hz Def: 30.00	Max: 650.00	
	P-Group: SETPOINT Active: Immediately QuickComm.: No		
	Defines fixed frequency setpoint 7.		
Index:	P1007[0] : 1st. Drive data set (DDS) P1007[1] : 2nd. Drive data set (DDS) P1007[2] : 3rd. Drive data set (DDS)		
Details:	See parameter P1001 (fixed frequency 1).		
P1008[3]	Fixed frequency 8	Min: -650.00	Level 3
	CStat: CUT Datatype: Float Unit: Hz Def: 35.00	Max: 650.00	
	P-Group: SETPOINT Active: Immediately QuickComm.: No		
	Defines fixed frequency setpoint 8.		
Index:	P1008[0] : 1st. Drive data set (DDS) P1008[1] : 2nd. Drive data set (DDS) P1008[2] : 3rd. Drive data set (DDS)		
Details:	See parameter P1001 (fixed frequency 1).		
P1009[3]	Fixed frequency 9	Min: -650.00	Level 3
	CStat: CUT Datatype: Float Unit: Hz Def: 40.00	Max: 650.00	
	P-Group: SETPOINT Active: Immediately QuickComm.: No		
	Defines fixed frequency setpoint 9.		
Index:	P1009[0] : 1st. Drive data set (DDS) P1009[1] : 2nd. Drive data set (DDS) P1009[2] : 3rd. Drive data set (DDS)		
Details:	See parameter P1001 (fixed frequency 1).		
P1010[3]	Fixed frequency 10	Min: -650.00	Level 3
	CStat: CUT Datatype: Float Unit: Hz Def: 45.00	Max: 650.00	
	P-Group: SETPOINT Active: Immediately QuickComm.: No		
	Defines fixed frequency setpoint 10.		
Index:	P1010[0] : 1st. Drive data set (DDS) P1010[1] : 2nd. Drive data set (DDS) P1010[2] : 3rd. Drive data set (DDS)		
Details:	See parameter P1001 (fixed frequency 1).		
P1011[3]	Fixed frequency 11	Min: -650.00	Level 3
	CStat: CUT Datatype: Float Unit: Hz Def: 50.00	Max: 650.00	
	P-Group: SETPOINT Active: Immediately QuickComm.: No		
	Defines fixed frequency setpoint 11.		
Index:	P1011[0] : 1st. Drive data set (DDS) P1011[1] : 2nd. Drive data set (DDS) P1011[2] : 3rd. Drive data set (DDS)		
Details:	See parameter P1001 (fixed frequency 1).		

P1012[3]	Fixed frequency 12	Min: -650.00	Level
	CStat: CUT Datatype: Float Unit: Hz Def: 55.00	3	
	P-Group: SETPOINT Active: Immediately QuickComm.: No Max: 650.00		
Defines fixed frequency setpoint 12.			
Index:	P1012[0] : 1st. Drive data set (DDS) P1012[1] : 2nd. Drive data set (DDS) P1012[2] : 3rd. Drive data set (DDS)		
Details:	See parameter P1001 (fixed frequency 1).		
P1013[3]	Fixed frequency 13	Min: -650.00	Level
	CStat: CUT Datatype: Float Unit: Hz Def: 60.00	3	
	P-Group: SETPOINT Active: Immediately QuickComm.: No Max: 650.00		
Defines fixed frequency setpoint 13.			
Index:	P1013[0] : 1st. Drive data set (DDS) P1013[1] : 2nd. Drive data set (DDS) P1013[2] : 3rd. Drive data set (DDS)		
Details:	See parameter P1001 (fixed frequency 1).		
P1014[3]	Fixed frequency 14	Min: -650.00	Level
	CStat: CUT Datatype: Float Unit: Hz Def: 65.00	3	
	P-Group: SETPOINT Active: Immediately QuickComm.: No Max: 650.00		
Defines fixed frequency setpoint 14.			
Index:	P1014[0] : 1st. Drive data set (DDS) P1014[1] : 2nd. Drive data set (DDS) P1014[2] : 3rd. Drive data set (DDS)		
Details:	See parameter P1001 (fixed frequency 1).		
P1015[3]	Fixed frequency 15	Min: -650.00	Level
	CStat: CUT Datatype: Float Unit: Hz Def: 65.00	3	
	P-Group: SETPOINT Active: Immediately QuickComm.: No Max: 650.00		
Defines fixed frequency setpoint 15.			
Index:	P1015[0] : 1st. Drive data set (DDS) P1015[1] : 2nd. Drive data set (DDS) P1015[2] : 3rd. Drive data set (DDS)		
Details:	See parameter P1001 (fixed frequency 1).		
P1016	Fixed frequency mode - Bit 0	Min: 1	Level
	CStat: CT Datatype: U16 Unit: - Def: 1	3	
	P-Group: SETPOINT Active: first confirm QuickComm.: No Max: 3		
Fixed frequencies can be selected in three different modes. Parameter P1016 defines the mode of selection Bit 0.			
Possible Settings:	1 Direct selection 2 Direct selection + ON command 3 Binary coded selection + ON command		
Details:	See table in P1001 (fixed frequency 1) for description of how to use fixed frequencies.		
P1017	Fixed frequency mode - Bit 1	Min: 1	Level
	CStat: CT Datatype: U16 Unit: - Def: 1	3	
	P-Group: SETPOINT Active: first confirm QuickComm.: No Max: 3		
Fixed frequencies can be selected in three different modes. Parameter P1017 defines the mode of selection Bit 1.			
Possible Settings:	1 Direct selection 2 Direct selection + ON command 3 Binary coded selection + ON command		
Details:	See table in P1001 (fixed frequency 1) for description of how to use fixed frequencies.		

P1018	Fixed frequency mode - Bit 2				Min: 1	Level 3
	CStat: CT	Datatype: U16	Unit: -	Def: 1		
	P-Group: SETPOINT	Active: first confirm	QuickComm.: No	Max: 3		

Fixed frequencies can be selected in three different modes. Parameter P1018 defines the mode of selection Bit 2.

Possible Settings:

- 1 Direct selection
- 2 Direct selection + ON command
- 3 Binary coded selection + ON command

Details:

See table in P1001 (fixed frequency 1) for description of how to use fixed frequencies.

P1019	Fixed frequency mode - Bit 3				Min: 1	Level 3
	CStat: CT	Datatype: U16	Unit: -	Def: 1		
	P-Group: SETPOINT	Active: first confirm	QuickComm.: No	Max: 3		

Fixed frequencies can be selected in three different modes. Parameter P1019 defines the mode of selection Bit 3.

Possible Settings:

- 1 Direct selection
- 2 Direct selection + ON command
- 3 Binary coded selection + ON command

Details:

See table in P1001 (fixed frequency 1) for description of how to use fixed frequencies.

P1020[3]	BI: Fixed freq. selection Bit 0				Min: 0:0	Level 3
	CStat: CT	Datatype: U32	Unit: -	Def: 0:0		
	P-Group: COMMANDS	Active: first confirm	QuickComm.: No	Max: 4000:0		

Defines origin of fixed frequency selection.

Index:

- P1020[0] : 1st. Command data set (CDS)
- P1020[1] : 2nd. Command data set (CDS)
- P1020[2] : 3rd. Command data set (CDS)

Common Settings:

- P1020 = 722.0 ==> Digital input 1
- P1021 = 722.1 ==> Digital input 2
- P1022 = 722.2 ==> Digital input 3
- P1023 = 722.3 ==> Digital input 4
- P1026 = 722.4 ==> Digital input 5
- P1028 = 722.5 ==> Digital input 6

Dependency:

Accessible only if P0701 - P0706 = 99 (function of digital inputs = BICO)

P1021[3]	BI: Fixed freq. selection Bit 1				Min: 0:0	Level 3
	CStat: CT	Datatype: U32	Unit: -	Def: 0:0		
	P-Group: COMMANDS	Active: first confirm	QuickComm.: No	Max: 4000:0		

Defines origin of fixed frequency selection.

Index:

- P1021[0] : 1st. Command data set (CDS)
- P1021[1] : 2nd. Command data set (CDS)
- P1021[2] : 3rd. Command data set (CDS)

Dependency:

Accessible only if P0701 - P0706 = 99 (function of digital inputs = BICO)

Details:

See P1020 (fixed frequency selection Bit 0) for most common settings

P1022[3]	BI: Fixed freq. selection Bit 2				Min: 0:0	Level 3
	CStat: CT	Datatype: U32	Unit: -	Def: 0:0		
	P-Group: COMMANDS	Active: first confirm	QuickComm.: No	Max: 4000:0		

Defines origin of fixed frequency selection.

Index:

- P1022[0] : 1st. Command data set (CDS)
- P1022[1] : 2nd. Command data set (CDS)
- P1022[2] : 3rd. Command data set (CDS)

Dependency:

Accessible only if P0701 - P0706 = 99 (function of digital inputs = BICO)

Details:

See P1020 (fixed frequency selection Bit 0) for most common settings

P1023[3]	BI: Fixed freq. selection Bit 3 CStat: CT Datatype: U32 Unit: - Min: 0:0 P-Group: COMMANDS Active: first confirm QuickComm.: No Def: 722:3 Max: 4000:0	Level 3
Defines origin of fixed frequency selection. Index: P1023[0] : 1st. Command data set (CDS) P1023[1] : 2nd. Command data set (CDS) P1023[2] : 3rd. Command data set (CDS) Dependency: Accessible only if P0701 - P0706 = 99 (function of digital inputs = BICO) Details: See P1020 (fixed frequency selection Bit 0) for most common settings		
r1024	CO: Act. fixed frequency Datatype: Float Unit: Hz Min: - P-Group: SETPOINT Def: - Max: -	Level 3
Displays sum total of selected fixed frequencies.		
P1025	Fixed frequency mode - Bit 4 CStat: CT Datatype: U16 Unit: - Min: 1 P-Group: SETPOINT Active: first confirm QuickComm.: No Def: 1 Max: 2	Level 3
Direct selection or direct selection + ON for bit 4 Possible Settings: 1 Direct selection 2 Direct selection + ON command Details: See parameter P1001 for description of how to use fixed frequencies.		
P1026[3]	BI: Fixed freq. selection Bit 4 CStat: CT Datatype: U32 Unit: - Min: 0:0 P-Group: COMMANDS Active: first confirm QuickComm.: No Def: 722:4 Max: 4000:0	Level 3
Defines origin of fixed frequency selection. Index: P1026[0] : 1st. Command data set (CDS) P1026[1] : 2nd. Command data set (CDS) P1026[2] : 3rd. Command data set (CDS) Dependency: Accessible only if P0701 - P0706 = 99 (function of digital inputs = BICO). Details: See P1020 (fixed frequency selection Bit 0) for most common settings.		
P1027	Fixed frequency mode - Bit 5 CStat: CT Datatype: U16 Unit: - Min: 1 P-Group: SETPOINT Active: first confirm QuickComm.: No Def: 1 Max: 2	Level 3
direct selection or direct selection + ON for bit 5 Possible Settings: 1 Direct selection 2 Direct selection + ON command Details: See parameter P1001 for description of how to use fixed frequencies.		
P1028[3]	BI: Fixed freq. selection Bit 5 CStat: CT Datatype: U32 Unit: - Min: 0:0 P-Group: COMMANDS Active: first confirm QuickComm.: No Def: 722:5 Max: 4000:0	Level 3
Defines origin of fixed frequency selection. Index: P1028[0] : 1st. Command data set (CDS) P1028[1] : 2nd. Command data set (CDS) P1028[2] : 3rd. Command data set (CDS) Dependency: Accessible only if P0701 - P0706 = 99 (function of digital inputs = BICO). Details: See P1020 (fixed frequency selection Bit 0) for most common settings.		

3.18 Motorized potentiometer (MOP)

P1031[3]	Setpoint memory of the MOP				Min: 0	Level 3
	CStat: CUT	Datatype: U16	Unit: -	Def: 0		
	P-Group: SETPOINT	Active: Immediately	QuickComm.: No	Max: 1		

Saves last motor potentiometer setpoint (MOP) that was active before OFF command or power down.

Possible Settings:

- 0 MOP setpoint will not be stored
- 1 MOP setpoint will be stored (P1040 is updated)

Index:

- P1031[0] : 1st. Drive data set (DDS)
- P1031[1] : 2nd. Drive data set (DDS)
- P1031[2] : 3rd. Drive data set (DDS)

Note:

On next ON command, motor potentiometer setpoint will be the saved value in parameter P1040 (setpoint of the MOP).

P1032	Inhibit negative MOP setpoints				Min: 0	Level 3
	CStat: CT	Datatype: U16	Unit: -	Def: 1		
	P-Group: SETPOINT	Active: first confirm	QuickComm.: No	Max: 1		

This parameter suppresses negative setpoints of the MOP output r1050.

Possible Settings:

- 0 Neg. MOP setpoint is allowed
- 1 Neg. MOP setpoint inhibited

Note:

The reversing functions (e.g. BOP-Reverse button if P0700 = 1) are not affected by the settings of P1032. Use P1110 to fully prevent change of direction in setpoint channel.

P1035[3]	BI: Enable MOP (UP-command)				Min: 0:0	Level 3
	CStat: CT	Datatype: U32	Unit: -	Def: 19:13		
	P-Group: COMMANDS	Active: first confirm	QuickComm.: No	Max: 4000:0		

Defines source for motor potentiometer setpoint increase frequency.

Index:

- P1035[0] : 1st. Command data set (CDS)
- P1035[1] : 2nd. Command data set (CDS)
- P1035[2] : 3rd. Command data set (CDS)

Common Settings:

- 722.0 = Digital input 1 (requires P0701 to be set to 99, BICO)
- 722.1 = Digital input 2 (requires P0702 to be set to 99, BICO)
- 722.2 = Digital input 3 (requires P0703 to be set to 99, BICO)
- 722.3 = Digital input 4 (requires P0704 to be set to 99, BICO)
- 722.4 = Digital input 5 (requires P0705 to be set to 99, BICO)
- 722.5 = Digital input 6 (requires P0706 to be set to 99, BICO)
- 722.6 = Digital input 7 (via analog input 1, requires P0707 to be set to 99)
- 722.7 = Digital input 8 (via analog input 2, requires P0708 to be set to 99)
- 19.D = MOP up via BOP

P1036[3]	BI: Enable MOP (DOWN-command)				Min: 0:0	Level 3
	CStat: CT	Datatype: U32	Unit: -	Def: 19:14		
	P-Group: COMMANDS	Active: first confirm	QuickComm.: No	Max: 4000:0		

Defines source for motor potentiometer setpoint decrease frequency.

Index:

- P1036[0] : 1st. Command data set (CDS)
- P1036[1] : 2nd. Command data set (CDS)
- P1036[2] : 3rd. Command data set (CDS)

Common Settings:

- 722.0 = Digital input 1 (requires P0701 to be set to 99, BICO)
- 722.1 = Digital input 2 (requires P0702 to be set to 99, BICO)
- 722.2 = Digital input 3 (requires P0703 to be set to 99, BICO)
- 722.3 = Digital input 4 (requires P0704 to be set to 99, BICO)
- 722.4 = Digital input 5 (requires P0705 to be set to 99, BICO)
- 722.5 = Digital input 6 (requires P0706 to be set to 99, BICO)
- 722.6 = Digital input 7 (via analog input 1, requires P0707 to be set to 99)
- 722.7 = Digital input 8 (via analog input 2, requires P0708 to be set to 99)
- 19.E = MOP down via BOP

P1040[3]	Setpoint of the MOP	Min: -650.00	Level 2	
	CStat: CUT	Datatype: Float		Unit: Hz
	P-Group: SETPOINT	Active: Immediately		QuickComm.: No
		Def: 5.00		
		Max: 650.00		

Determines setpoint for motor potentiometer control (P1000 = 1).

Index:

- P1040[0] : 1st. Drive data set (DDS)
- P1040[1] : 2nd. Drive data set (DDS)
- P1040[2] : 3rd. Drive data set (DDS)

Note:

- If motor potentiometer setpoint is selected either as main setpoint or additional setpoint, the reverse direction will be inhibited by default of P1032 (inhibit reverse direction of MOP).
- To re-enable reverse direction, set P1032 = 0.

r1050	CO: Act. Output freq. of the MOP	Min: -	Level 3	
		Datatype: Float		Unit: Hz
	P-Group: SETPOINT			Def: -
		Max: -		

Displays output frequency of motor potentiometer setpoint ([Hz]).

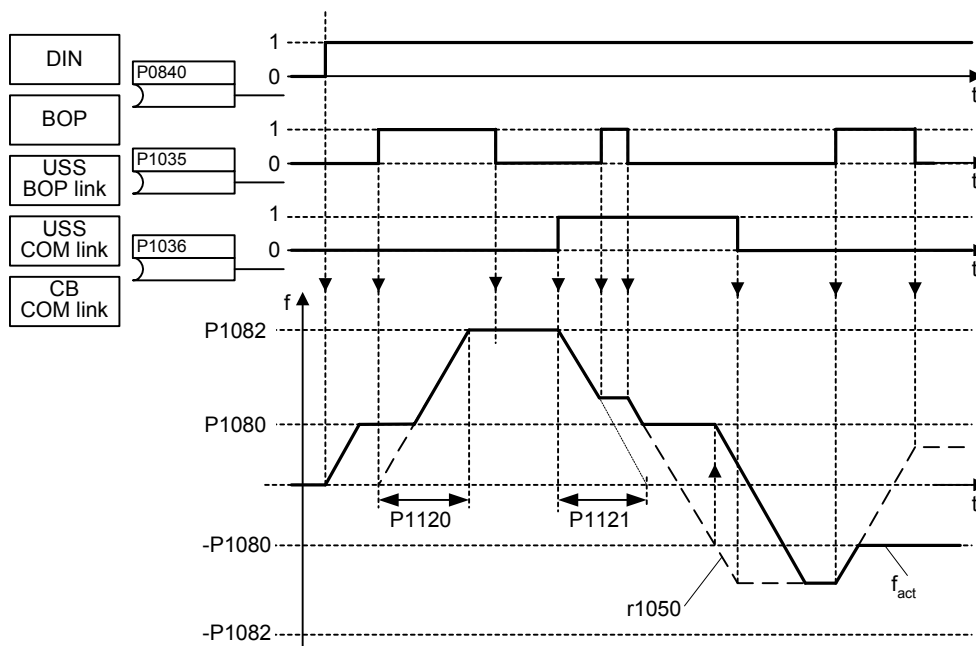

Possible parameter settings for the selection of MOP:

	Selection	MOP up	MOP down
DIN	P0719 = 0, P0700 = 2, P1000 = 1 or P0719 = 1, P0700 = 2	P0702 = 13 (DIN2)	P0703 = 14 (DIN3)
BOP	P0719 = 0, P0700 = 1, P1000 = 1 or P0719 = 1, P0700 = 1 or P0719 = 11	UP button	DOWN button
USS on BOP link	P0719 = 0, P0700 = 4, P1000 = 1 or P0719 = 1, P0700 = 4 or P0719 = 41	USS control word r2032 Bit13	USS control word r2032 Bit14
USS on COM link	P0719 = 0, P0700 = 5, P1000 = 1 or P0719 = 1, P0700 = 5 or P0719 = 51	USS control word r2036 Bit13	USS control word r2036 Bit14
CB	P0719 = 0, P0700 = 6, P1000 = 1 or P0719 = 1, P0700 = 6 or P0719 = 61	CB control word r2090 Bit13	CB control word r2090 Bit14

3.19 Setpoint channel

P1070[3]	CI: Main setpoint	Min: 0:0	Level 3
	CStat: CT Datatype: U32 Unit: -	Def: 755:0	
	P-Group: SETPOINT Active: first confirm QuickComm.: No	Max: 4000:0	

Defines source of main setpoint.

Index:

- P1070[0] : 1st. Command data set (CDS)
- P1070[1] : 2nd. Command data set (CDS)
- P1070[2] : 3rd. Command data set (CDS)

Common Settings:

- 755 = Analog input 1 setpoint
- 1024 = Fixed frequency setpoint
- 1050 = Motor potentiometer (MOP) setpoint

P1071[3]	CI: Main setpoint scaling	Min: 0:0	Level 3
	CStat: CT Datatype: U32 Unit: -	Def: 1:0	
	P-Group: SETPOINT Active: first confirm QuickComm.: No	Max: 4000:0	

Defines source of the main setpoint scaling.

Index:

- P1071[0] : 1st. Command data set (CDS)
- P1071[1] : 2nd. Command data set (CDS)
- P1071[2] : 3rd. Command data set (CDS)

Common Settings:

- 755 = Analog input 1 setpoint
- 1024 = Fixed frequency setpoint
- 1050 = Motor potentiometer (MOP) setpoint

P1074[3]	BI: Disable additional setpoint	Min: 0:0	Level 3
	CStat: CUT Datatype: U32 Unit: -	Def: 0:0	
	P-Group: COMMANDS Active: first confirm QuickComm.: No	Max: 4000:0	

Disables additional setpoint

Index:

- P1074[0] : 1st. Command data set (CDS)
- P1074[1] : 2nd. Command data set (CDS)
- P1074[2] : 3rd. Command data set (CDS)

Common Settings:

- 722.0 = Digital input 1 (requires P0701 to be set to 99, BICO)
- 722.1 = Digital input 2 (requires P0702 to be set to 99, BICO)
- 722.2 = Digital input 3 (requires P0703 to be set to 99, BICO)
- 722.3 = Digital input 4 (requires P0704 to be set to 99, BICO)
- 722.4 = Digital input 5 (requires P0705 to be set to 99, BICO)
- 722.5 = Digital input 6 (requires P0706 to be set to 99, BICO)
- 722.6 = Digital input 7 (via analog input 1, requires P0707 to be set to 99)
- 722.7 = Digital input 8 (via analog input 2, requires P0708 to be set to 99)

P1075[3]	CI: Additional setpoint	Min: 0:0	Level 3
	CStat: CT Datatype: U32 Unit: -	Def: 0:0	
	P-Group: SETPOINT Active: first confirm QuickComm.: No	Max: 4000:0	

Defines source of the additional setpoint (to be added to main setpoint).

Index:

- P1075[0] : 1st. Command data set (CDS)
- P1075[1] : 2nd. Command data set (CDS)
- P1075[2] : 3rd. Command data set (CDS)

Common Settings:

- 755 = Analog input 1 setpoint
- 1024 = Fixed frequency setpoint
- 1050 = Motor potentiometer (MOP) setpoint

P1076[3]	CI: Additional setpoint scaling	Min: 0:0	Level 3	
	CStat: CT	Datatype: U32		Unit: -
	P-Group: SETPOINT	Active: first confirm		QuickComm.: No
		Def: 1:0		
		Max: 4000:0		

Defines source of scaling for additional setpoint (to be added to main setpoint).

Index:

- P1076[0] : 1st. Command data set (CDS)
- P1076[1] : 2nd. Command data set (CDS)
- P1076[2] : 3rd. Command data set (CDS)

Common Settings:

- 1 = Scaling of 1.0 (100%)
- 755 = Analog input 1 Setpoint
- 1024 = Fixed Frequency Setpoint
- 1050 = MOP Setpoint

r1078	CO: Total frequency setpoint	Min: -	Level 3	
		Datatype: Float		Unit: Hz
	P-Group: SETPOINT	Active: first confirm		QuickComm.: No
		Def: -		
		Max: -		

Displays sum of main and additional setpoints in [Hz].

P1080[3]	Min. frequency	Min: 0.00	Level 1	
	CStat: CUT	Datatype: Float		Unit: Hz
	P-Group: SETPOINT	Active: Immediately		QuickComm.: Yes
		Def: 0.00		
		Max: 650.00		

Sets minimum motor frequency [Hz] at which motor will run irrespective of frequency setpoint.

The minimum frequency P1080 represents a masking frequency of 0 Hz for all frequency target value sources (e.g. ADC, MOP, FF, USS), with the exception of the JOG target value source (analogous to P1091). Thus the frequency band +/- P1080 is run through in optimum time by means of the acceleration/deceleration ramps. Dwelling in the frequency band is not possible (see example).

Furthermore, an undershoot of the actual frequency f_{act} below min. frequency P1080 is output by the following signal function.

Index:

- P1080[0] : 1st. Drive data set (DDS)
- P1080[1] : 2nd. Drive data set (DDS)
- P1080[2] : 3rd. Drive data set (DDS)

Example:

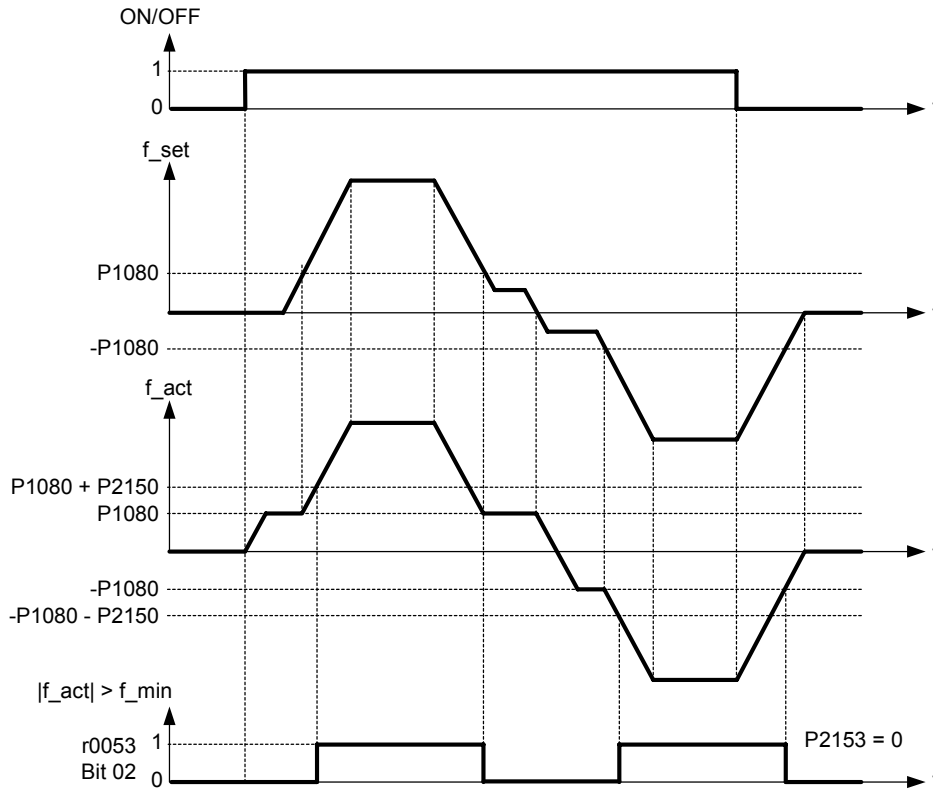

Note:

Value set here is valid both for clockwise and for anticlockwise rotation.

Under certain conditions (e.g. ramping, current limiting), motor can run below minimum frequency.

P1082[3]	Max. frequency			Min: 0.00	Level 1
	CStat: CT	Datatype: Float	Unit: Hz	Def: 50.00	
	P-Group: SETPOINT	Active: first confirm	QuickComm.: Yes	Max: 650.00	

Sets maximum motor frequency [Hz] at which motor will run irrespective of the frequency setpoint. The value set here is valid for both clockwise and anticlockwise rotation.

Furthermore, the monitoring function $|f_{act}| \geq P1082$ (r0052 Bit10, see example below) is affected by this parameter.

Index:

- P1082[0] : 1st. Drive data set (DDS)
- P1082[1] : 2nd. Drive data set (DDS)
- P1082[2] : 3rd. Drive data set (DDS)

Example:

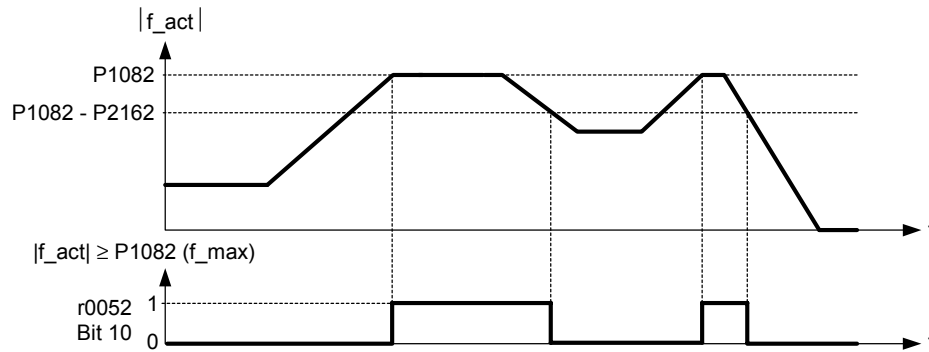

Dependency:

The maximal value of motor frequency P1082 is limited to pulse frequency P1800. P1082 is dependent on the derating characteristic as followed:

		P1800			
		2 kHz	4 kHz	6 kHz	8 - 16 kHz
f_{max}	P1082	0 - 133.3 Hz	0 - 266.6 Hz	0 - 400 Hz	0 - 650 Hz

The resultant value is displayed in r1084 (resultant maximum frequency).

The maximum output frequency of inverter can be exceeded if one of the following is active:

- p1335 ≠ 0 (Slip compensation active) :

$$f_{max}(p1335) = f_{max} + f_{slip,max} = p1082 + \frac{p1336}{100} \cdot \frac{r0330}{100} \cdot p0310$$

- p1200 ≠ 0 (Flying restart active) :

$$f_{max}(p1200) = f_{max} + 2 \cdot f_{slip,nom} = p1082 + 2 \cdot \frac{r0330}{100} \cdot p0310$$

Note:

When using the setpoint source

- Analog Input
- USS
- CB (e.g. PROFIBUS)

The setpoint frequency (in Hz) is cyclically calculated using a percentage value (e.g. for the analog input r0754) or a hexadecimal value (e.g. for the USS r2018[1]) and the reference frequency P2000.

If for example P1082 = 80 Hz, P2000 = 50 Hz and the analog input is parameterised with P0757 = 0 V, P0758 = 0 %, P0759 = 10 V, P0760 = 100 %, a setpoint frequency of 50 Hz will be applied at 10 V of the analog input.

P1091[3]	Skip frequency 1			Min: 0.00	Level 3
	CStat: CUT	Datatype: Float	Unit: Hz	Def: 0.00	
	P-Group: SETPOINT	Active: Immediately	QuickComm.: No	Max: 650.00	

Defines skip frequency 1 which avoids effects of mechanical resonance and suppresses frequencies within +/- P1101 (skip frequency bandwidth).

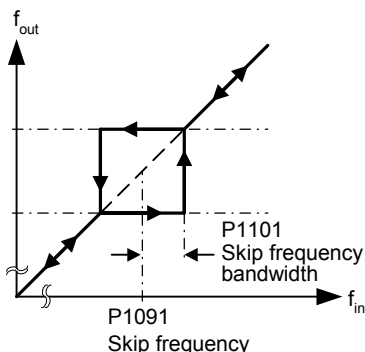

Index:

- P1091[0] : 1st. Drive data set (DDS)
- P1091[1] : 2nd. Drive data set (DDS)
- P1091[2] : 3rd. Drive data set (DDS)

Notice:

- Stationary operation is not possible within the suppressed frequency range; the range is merely passed through (on the ramp).
- For example, if P1091 = 10 Hz and P1101 = 2 Hz, it is not possible to operate continuously between 10 Hz +/- 2 Hz (i.e. between 8 and 12 Hz).

P1092[3]	Skip frequency 2			Min: 0.00	Level 3
	CStat: CUT	Datatype: Float	Unit: Hz	Def: 0.00	
	P-Group: SETPOINT	Active: Immediately	QuickComm.: No	Max: 650.00	

Defines skip frequency 2 which avoids effects of mechanical resonance and suppresses frequencies within +/- P1101 (skip frequency bandwidth).

Index:

- P1092[0] : 1st. Drive data set (DDS)
- P1092[1] : 2nd. Drive data set (DDS)
- P1092[2] : 3rd. Drive data set (DDS)

Details:

See P1091 (skip frequency 1).

P1093[3]	Skip frequency 3			Min: 0.00	Level 3
	CStat: CUT	Datatype: Float	Unit: Hz	Def: 0.00	
	P-Group: SETPOINT	Active: Immediately	QuickComm.: No	Max: 650.00	

Defines skip frequency 3 which avoids effects of mechanical resonance and suppresses frequencies within +/- P1101 (skip frequency bandwidth).

Index:

- P1093[0] : 1st. Drive data set (DDS)
- P1093[1] : 2nd. Drive data set (DDS)
- P1093[2] : 3rd. Drive data set (DDS)

Details:

See P1091 (skip frequency 1).

P1094[3]	Skip frequency 4			Min: 0.00	Level 3
	CStat: CUT	Datatype: Float	Unit: Hz	Def: 0.00	
	P-Group: SETPOINT	Active: Immediately	QuickComm.: No	Max: 650.00	

Defines skip frequency 4 which avoids effects of mechanical resonance and suppresses frequencies within +/- P1101 (skip frequency bandwidth).

Index:

- P1094[0] : 1st. Drive data set (DDS)
- P1094[1] : 2nd. Drive data set (DDS)
- P1094[2] : 3rd. Drive data set (DDS)

Details:

See P1091 (skip frequency 1).

P1101[3]	Skip frequency bandwidth	Min: 0.00	Level 3	
	CStat: CUT	Datatype: Float		Unit: Hz
	P-Group: SETPOINT	Active: Immediately		QuickComm.: No

Delivers frequency bandwidth to be applied to skip frequencies (in [Hz]).

Index:

- P1101[0] : 1st. Drive data set (DDS)
- P1101[1] : 2nd. Drive data set (DDS)
- P1101[2] : 3rd. Drive data set (DDS)

Details:

See P1091 (skip frequency 1).

P1110[3]	BI: Inhibit neg. freq. setpoint	Min: 0:0	Level 3	
	CStat: CT	Datatype: U32		Unit: -
	P-Group: COMMANDS	Active: first confirm		QuickComm.: No

This parameter suppresses negative setpoints. Therefore, modification of the motor direction is inhibited to the setpoint channel.

Index:

- P1110[0] : 1st. Command data set (CDS)
- P1110[1] : 2nd. Command data set (CDS)
- P1110[2] : 3rd. Command data set (CDS)

Common Settings:

- 0 = Disabled
- 1 = Enabled

Notice:

Where

- If a min. frequency (P1080) and a negative setpoint are given, the motor is accelerated by a positive value in relationship to the min. frequency.
- This function does not disable the "reverse command functions" (e.g. Reverse, ON left); rather, a reverse command causes motor to run in the positive direction only, as described above.

P1110 = 1

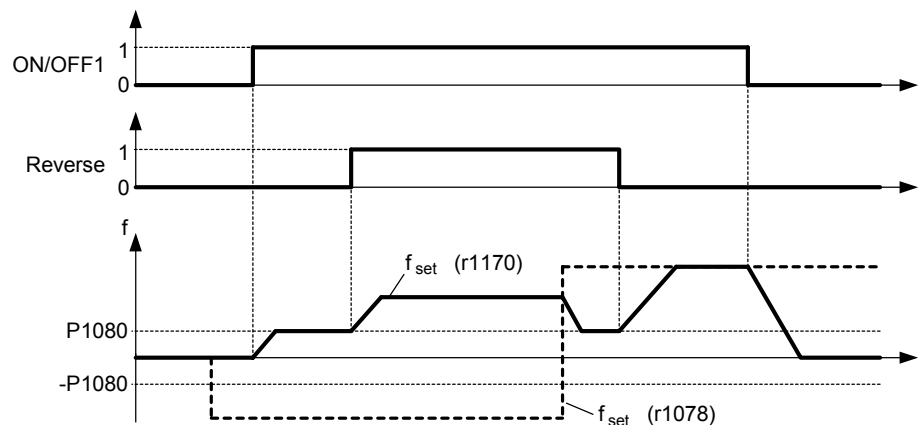

P1113[3]	BI: Reverse	Min: 0:0	Level 3	
	CStat: CT	Datatype: U32		Unit: -
	P-Group: COMMANDS	Active: first confirm		QuickComm.: No

Defines source of reverse command.

Index:

- P1113[0] : 1st. Command data set (CDS)
- P1113[1] : 2nd. Command data set (CDS)
- P1113[2] : 3rd. Command data set (CDS)

Common Settings:

- 722.0 = Digital input 1 (requires P0701 to be set to 99, BICO)
- 722.1 = Digital input 2 (requires P0702 to be set to 99, BICO)
- 722.2 = Digital input 3 (requires P0703 to be set to 99, BICO)
- 722.3 = Digital input 4 (requires P0704 to be set to 99, BICO)
- 722.4 = Digital input 5 (requires P0705 to be set to 99, BICO)
- 722.5 = Digital input 6 (requires P0706 to be set to 99, BICO)
- 19.B = Reverse via BOP

Dependency:

Active only when P0719 < 10. See parameter P0719 (Selection of command/setpoint source).

r1114	CO: Freq. setp. after dir. ctrl.	Min: -	Level 3	
		Datatype: Float		Unit: Hz
	P-Group: SETPOINT	Def: -		Max: -

Displays setpoint frequency after change of direction.

3.20 Ramp-function generator

r1119	CO: Freq. setpoint before RFG	Min: -	Level 3
	Datatype: Float Unit: Hz	Def: - Max: -	
P-Group: SETPOINT			

Displays output frequency after modification by other functions, e.g.:

- P1110 BI: Inhibit neg. freq. setpoint,
- P1091 - P1094 skip frequencies,
- P1080 Min. frequency,
- P1082 Max. frequency,
- limitations,
- etc.

P1120[3]	Ramp-up time	Min: 0.00	Level 1
	CStat: CUT	Datatype: Float Unit: s	
P-Group: SETPOINT		Active: first confirm	QuickComm.: Yes
		Max: 650.00	

Time taken for motor to accelerate from standstill up to maximum motor frequency (P1082) when no rounding is used.

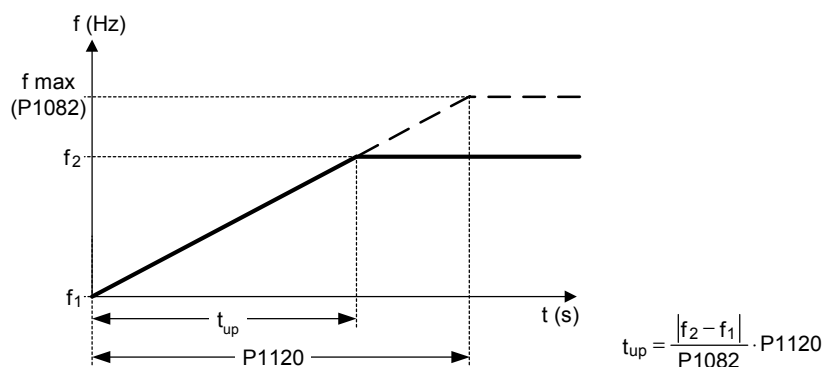

Setting the ramp-up time too short can cause the inverter to trip (overcurrent).

Index:

- P1120[0] : 1st. Drive data set (DDS)
- P1120[1] : 2nd. Drive data set (DDS)
- P1120[2] : 3rd. Drive data set (DDS)

Note:

If an external frequency setpoint with set ramp rates is used (e.g. from a PLC). The best way to achieve optimum drive performance is to set ramp times in P1120 and P1121 slightly shorter than those of the PLC.

Notice:

- Ramp times will be used as follows:
- P1060 / P1061 : JOG mode is active
 - P1120 / P1121 : Normal mode (ON/OFF) is active
 - P1060 / P1061 : Normal mode (ON/OFF) and P1124 is active

P1121[3]	Ramp-down time	Datatype: Float	Unit: s	Min: 0.00	Level 1
	CStat: CUT	Active: first confirm	QuickComm.: Yes	Def: 30.00	
	P-Group: SETPOINT			Max: 650.00	

Time taken for motor to decelerate from maximum motor frequency (P1082) down to standstill when no rounding is used.

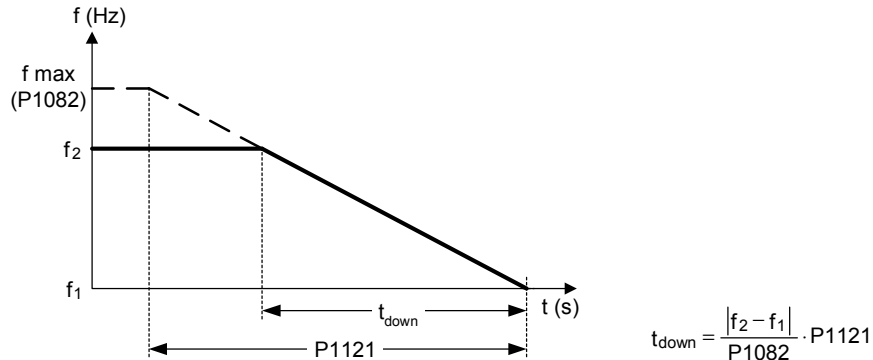

Index:

- P1121[0] : 1st. Drive data set (DDS)
- P1121[1] : 2nd. Drive data set (DDS)
- P1121[2] : 3rd. Drive data set (DDS)

Notice:

- Setting the ramp-down time too short can cause the inverter to trip (overcurrent (F0001) / overvoltage (F0002)).
 Ramp times will be used as follows:
- P1060 / P1061 : JOG mode is active
 - P1120 / P1121 : Normal mode (ON/OFF) is active
 - P1060 / P1061 : Normal mode (ON/OFF) and P1124 is active

P1130[3]	Ramp-up initial rounding time	Datatype: Float	Unit: s	Min: 0.00	Level 2
	CStat: CUT	Active: first confirm	QuickComm.: No	Def: 0.00	
	P-Group: SETPOINT			Max: 40.00	

Defines initial rounding time in seconds as shown on the diagram below.

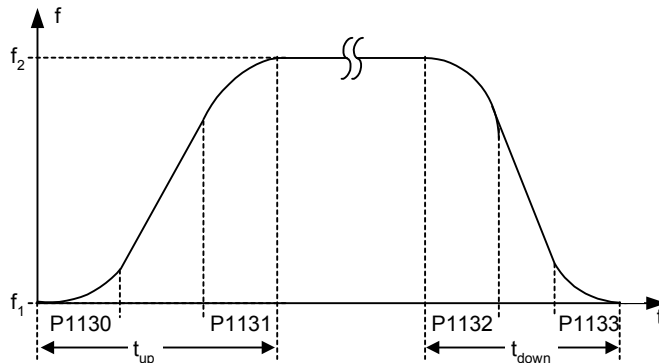

where:

for $\frac{f_2 - f_1}{P1082} \cdot P1120 \geq \frac{1}{2}(P1130 + P1131)$

$$t_{up} = \frac{1}{2}(P1130 + P1131) + \frac{f_2 - f_1}{P1082} \cdot P1120$$

for $\frac{f_2 - f_1}{P1082} \cdot P1121 \geq \frac{1}{2}(P1132 + P1133)$

$$t_{down} = \frac{1}{2}(P1132 + P1133) + \frac{f_2 - f_1}{P1082} \cdot P1121$$

Index:

- P1130[0] : 1st. Drive data set (DDS)
- P1130[1] : 2nd. Drive data set (DDS)
- P1130[2] : 3rd. Drive data set (DDS)

Note:

- If short or zero ramp times (P1120, P1121 < P1130, P1131, P1132, P1133) are set, the total ramp up time (t_{up}) or ramp down time (t_{down}) will not depend on P1130.
- See equations above for valid conditions to calculate t_{up} and t_{down}.
- Rounding times are recommended, since they prevent an abrupt response, thus avoiding detrimental effects on the mechanics.
- Rounding times are not recommended when analog inputs are used, since they would result in overshoot/undershoot in the inverter response.

P1131[3]	Ramp-up final rounding time	Min: 0.00	Level 2	
	CStat: CUT	Datatype: Float		Unit: s
	P-Group: SETPOINT	Active: first confirm		QuickComm.: No

Defines rounding time at end of ramp-up as shown in P1130 (ramp-up initial rounding time).

Index:

- P1131[0] : 1st. Drive data set (DDS)
- P1131[1] : 2nd. Drive data set (DDS)
- P1131[2] : 3rd. Drive data set (DDS)

Details:

See parameter P1130.

P1132[3]	Ramp-down initial rounding time	Min: 0.00	Level 2	
	CStat: CUT	Datatype: Float		Unit: s
	P-Group: SETPOINT	Active: first confirm		QuickComm.: No

Defines rounding time at start of ramp-down as shown in P1130 (ramp-up initial rounding time).

Index:

- P1132[0] : 1st. Drive data set (DDS)
- P1132[1] : 2nd. Drive data set (DDS)
- P1132[2] : 3rd. Drive data set (DDS)

Details:

See parameter P1130.

P1133[3]	Ramp-down final rounding time	Min: 0.00	Level 2	
	CStat: CUT	Datatype: Float		Unit: s
	P-Group: SETPOINT	Active: first confirm		QuickComm.: No

Defines rounding time at end of ramp-down as shown in P1130 (ramp-up initial rounding time).

Index:

- P1133[0] : 1st. Drive data set (DDS)
- P1133[1] : 2nd. Drive data set (DDS)
- P1133[2] : 3rd. Drive data set (DDS)

Details:

See parameter P1130.

P1134[3]	Rounding type	Datatype: U16	Unit: -	Min: 0	Level 2
	CStat: CUT	Active: Immediately	QuickComm.: No	Def: 0	
	P-Group: SETPOINT			Max: 1	

Defines the smoothing which is active by setpoint modifications during acceleration or deceleration (e.g. new setpoint, OFF1, OFF3, REV).

This smoothing is applied, if the motor is ramped-up or ramped-down and

- P1134 = 0,
- P1132 > 0, P1133 > 0 and
- the setpoint is not yet reached.

P1132 > 0, P1133 > 0

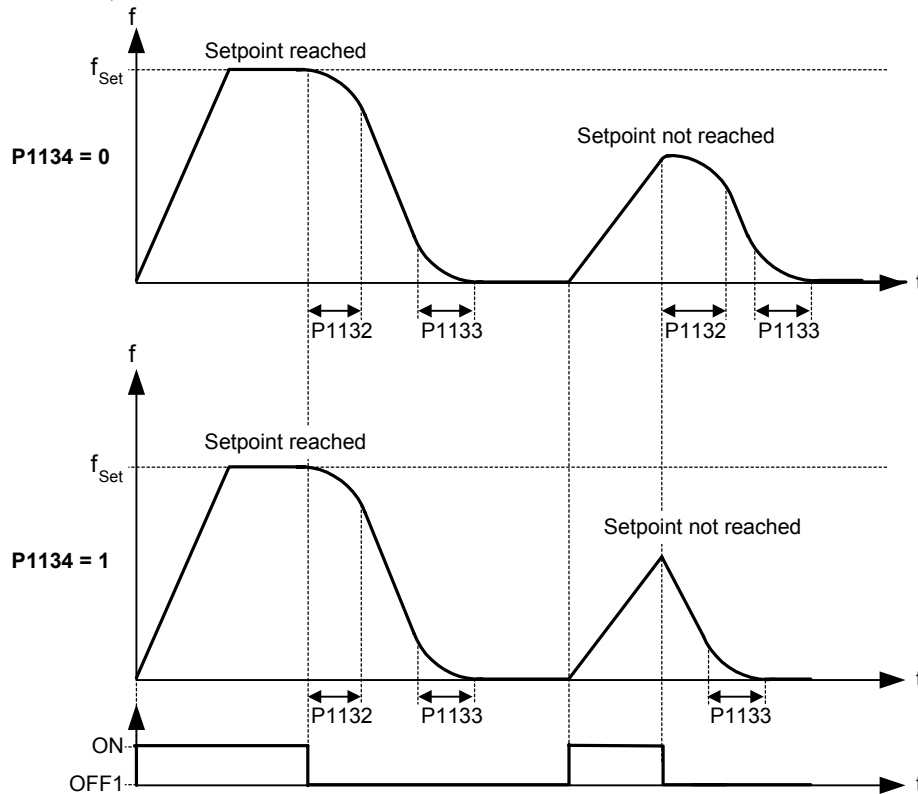

Possible Settings:

- 0 Continuous smoothing
- 1 Discontinuous smoothing

Index:

- P1134[0] : 1st. Drive data set (DDS)
- P1134[1] : 2nd. Drive data set (DDS)
- P1134[2] : 3rd. Drive data set (DDS)

Dependency:

No effect until P1132 (Ramp-down initial rounding time) or P1133 (Ramp-down final rounding time) > 0 s.

P1135[3]	OFF3 ramp-down time	Min: 0.00	Level 2	
	CStat: CUT	Datatype: Float		Unit: s
	P-Group: SETPOINT	Active: first confirm		QuickComm.: Yes
		Def: 5.00		
		Max: 650.00		

Defines ramp-down time from maximum frequency to standstill for OFF3 command.

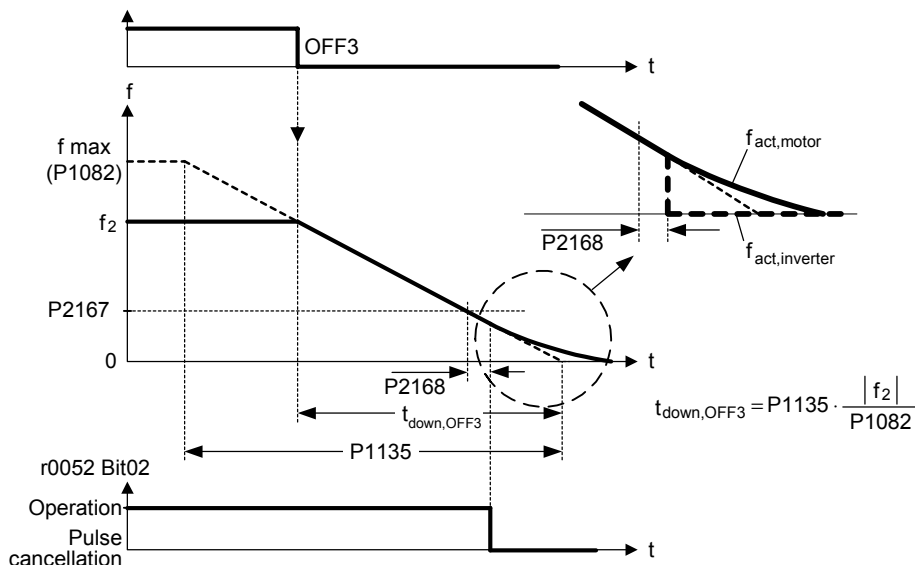

Index:

- P1135[0] : 1st. Drive data set (DDS)
- P1135[1] : 2nd. Drive data set (DDS)
- P1135[2] : 3rd. Drive data set (DDS)

Note:

This time may be exceeded if the VDC_max. level is reached.

P1140[3]	BI: RFG enable	Min: 0:0	Level 3	
	CStat: CT	Datatype: U32		Unit: -
	P-Group: COMMANDS	Active: first confirm		QuickComm.: No
		Def: 1:0		
		Max: 4000:0		

Defines command source of RFG enable command (RFG: ramp function generator). If binary input is equal to zero then the RFG output will be set immediately to 0.

Index:

- P1140[0] : 1st. Command data set (CDS)
- P1140[1] : 2nd. Command data set (CDS)
- P1140[2] : 3rd. Command data set (CDS)

P1141[3]	BI: RFG start	Min: 0:0	Level 3	
	CStat: CT	Datatype: U32		Unit: -
	P-Group: COMMANDS	Active: first confirm		QuickComm.: No
		Def: 1:0		
		Max: 4000:0		

Defines command source of RFG start command (RFG: ramp function generator). If binary input is equal to zero then the RFG output is held at it present value.

Index:

- P1141[0] : 1st. Command data set (CDS)
- P1141[1] : 2nd. Command data set (CDS)
- P1141[2] : 3rd. Command data set (CDS)

P1142[3]	BI: RFG enable setpoint	Min: 0:0	Level 3	
	CStat: CT	Datatype: U32		Unit: -
	P-Group: COMMANDS	Active: first confirm		QuickComm.: No
		Def: 1:0		
		Max: 4000:0		

Defines command source of RFG enable setpoint command (RFG: ramp function generator). If binary input is equal to zero then the RFG input will be set to zero and the RFG output will be ramp-down to zero.

Index:

- P1142[0] : 1st. Command data set (CDS)
- P1142[1] : 2nd. Command data set (CDS)
- P1142[2] : 3rd. Command data set (CDS)

r1170	CO: Frequency setpoint after RFG	Min: -	Level 3	
		Datatype: Float		Unit: Hz
	P-Group: SETPOINT	Active: -		QuickComm.: -
		Def: -		
		Max: -		

Displays overall frequency setpoint after ramp generator.

3.21 Flying restart

P1200	Flying start	Datatype: U16	Unit: -	Min: 0	Level 3
	CStat: CUT	Active: first confirm	QuickComm.: No	Def: 0	
	P-Group: FUNC			Max: 6	

Starts inverter onto a spinning motor by rapidly changing the output frequency of the inverter until the actual motor speed has been found. Then, the motor runs up to setpoint using the normal ramp time.

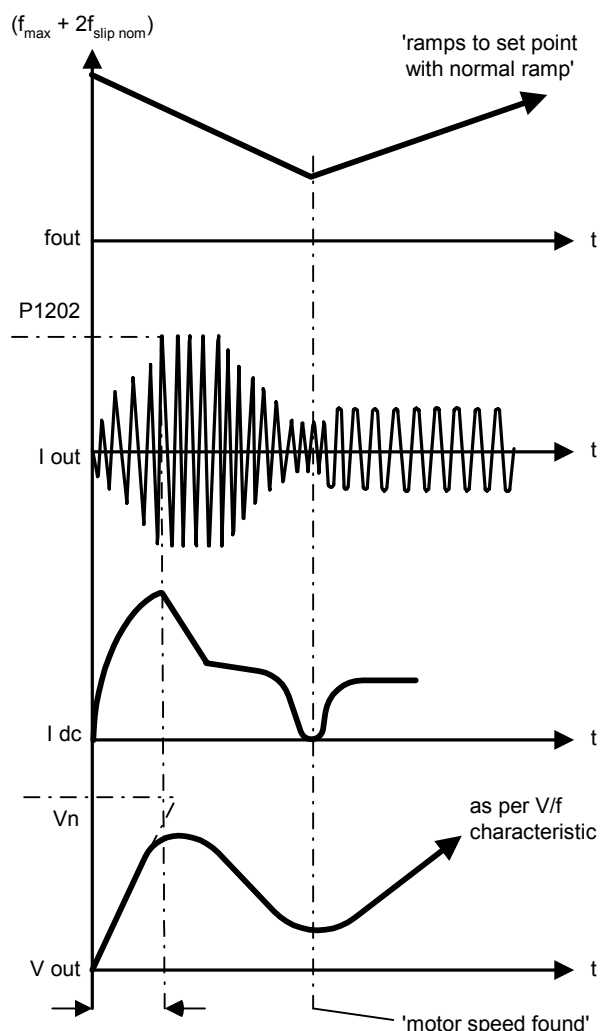

Possible Settings:

- 0 Flying start disabled
- 1 Flying start is always active, start in direction of setpoint
- 2 Flying start is active if power on, fault, OFF2, start in direction of setpoint
- 3 Flying start is active if fault, OFF2, start in direction of setpoint
- 4 Flying start is always active, only in direction of setpoint
- 5 Flying start is active if power on, fault, OFF2, only in direction of setpoint
- 6 Flying start is active if fault, OFF2, only in direction of setpoint

Note:

- Useful for motors with high inertia loads.
- Settings 1 to 3 search in both directions.
- Settings 4 to 6 search only in direction of setpoint.
- Flying start must be used in cases where the motor may still be turning (e.g. after a short mains break) or can be driven by the load. Otherwise, overcurrent trips will occur.

P1202[3]	Motor-current: Flying start				Min: 10	Level 3
	CStat: CUT	Datatype: U16	Unit: %	Def: 100		
	P-Group: FUNC	Active: first confirm	QuickComm.: No	Max: 200		

Defines search current used for flying start. Value is in [%] based on rated motor current (P0305).

Index:

- P1202[0] : 1st. Drive data set (DDS)
- P1202[1] : 2nd. Drive data set (DDS)
- P1202[2] : 3rd. Drive data set (DDS)

Note:

- If the search current is reduced, the flying restart behavior can be improved if the system inertia is not very high.

P1203[3]	Search rate: Flying start				Min: 10	Level 3
	CStat: CUT	Datatype: U16	Unit: %	Def: 100		
	P-Group: FUNC	Active: first confirm	QuickComm.: No	Max: 200		

Sets factor by which the output frequency changes during flying start to synchronize with turning motor. This value is entered in [%] defines the reciprocal initial gradient in the search sequence (see curve below). Parameter P1203 influences the time taken to search for the motor frequency.

The search time is the time taken to search through all frequencies between max. frequency $P1082 + 2 \times f_{slip}$ to 0 Hz.

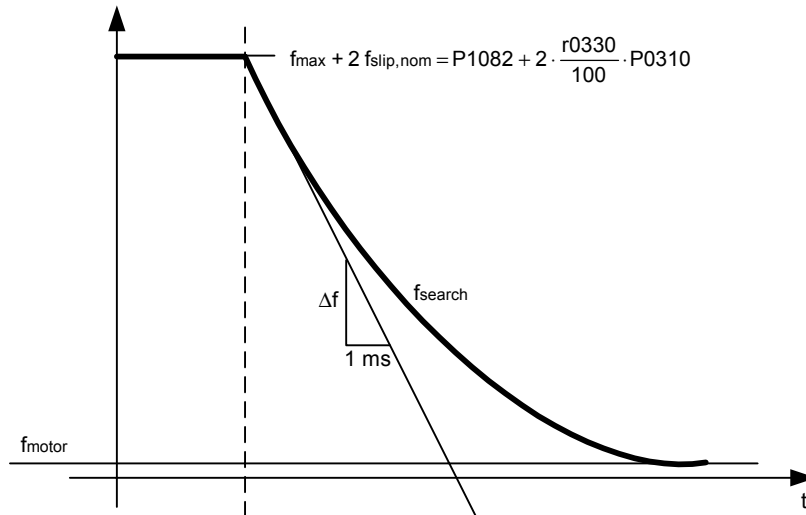

$$P1203 [\%] = \frac{\Delta t [\text{ms}]}{\Delta f [\text{Hz}]} \cdot \frac{f_{slip, \text{nom}} [\text{Hz}]}{1 [\text{ms}]} \cdot 2 [\%] \Rightarrow \Delta f = \frac{2 [\%]}{P1203 [\%]} \cdot \frac{r0330}{100} \cdot P0310$$

P1203 = 100 % is defined as giving a rate of 2 % of $f_{slip, \text{nom}} / [\text{ms}]$.
 P1203 = 200 % would result in a rate of frequency change of 1 % of $f_{slip, \text{nom}} / [\text{ms}]$.

Index:

- P1203[0] : 1st. Drive data set (DDS)
- P1203[1] : 2nd. Drive data set (DDS)
- P1203[2] : 3rd. Drive data set (DDS)

Example:

For a motor with 50 Hz, 1350 rpm, 100 % would produce a maximum search time of 600 ms. If the motor is turning, the motor frequency is found in a shorter time.

Note:

- A higher value produces a flatter gradient and thus a longer search time.
- A lower value has the opposite effect.

3.22 Automatic restart

P1210	Automatic restart			Min: 0	Level 3
	CStat: CUT	Datatype: U16	Unit: -	Def: 1	
	P-Group: FUNC	Active: first confirm	QuickComm.: No	Max: 6	

Configures automatic restart function

Possible Settings:

- 0 Disabled
- 1 Trip reset after power on, P1211 disabled
- 2 Restart after mains blackout, P1211 disabled
- 3 Restart after mains brownout or fault, P1211 enabled
- 4 Restart after mains brownout, P1211 enabled
- 5 Restart after mains blackout and fault, P1211 disabled
- 6 Restart after mains brown- /blackout or fault, P1211 disabled

Dependency:

Automatic restart requires constant ON command via a digital input wire link.



Caution:

P1210 > 2 can cause the motor to restart automatically without toggling the ON command !

Notice:

A "mains brownout" is where the power is interrupted and re-applied before the display on the BOP (if one is fitted to the inverter) has gone dark (a very short mains break where the DC link has not fully collapsed).

A "mains blackout" is where the display has gone dark (a long mains break where the DC link has fully collapsed) before the power is re-applied.

P1210 = 0:
Automatic restart is disabled.

P1210 = 1:
The inverter will acknowledge (reset) faults i.e. it will reset a fault when the is re-applied. This means the inverter must be fully powered down, a brownout is not sufficed. The inverter will not run until the ON command has been toggled.

P1210 = 2:
The inverter will acknowledge the fault F0003 at power on after blackout and restarts the drive. It is necessary that the ON command is wired via digital input (DIN).

P1210 = 3:
For these settings it is fundamental that the drive only restarts if it has been in a RUN state at the time of the faults (F0003, etc.). The inverter will acknowledge the fault and restarts the drive after a blackout or brownout. It is necessary that the ON command is wired via digital input (DIN).

P1210 = 4:
For these settings it is fundamental that the drive only restarts if it has been in a RUN state at the time of the fault (F0003). The inverter will acknowledge the fault and restarts the drive after a blackout or brownout. It is necessary that the ON command is wired via digital input (DIN).

P1210 = 5:
The inverter will acknowledge the faults F0003 etc. at power on after blackout and restarts the drive. It is necessary that the ON command is wired via digital input (DIN).

P1210 = 6:
The inverter will acknowledge the faults (F0003 etc.) at power on after blackout or brownout and restarts the drive. It is necessary that the ON command is wired via digital input (DIN). Setting 6 causes the motor to restart immediately.

Following table presents an overview of parameter P1210 and its functionality.

P1210	ON always active (permanent)				ON in no-voltage condition	
	Fault F0003 on Blackout	Fault F0003 on Brownout	All other faults on Blackout	All other faults on Brownout	All faults on Blackout	No faults on Blackout
0	-	-	-	-	-	-
1	Fault acknowl.	-	Fault acknowl.	-	Fault acknowl.	-
2	Fault acknowl. + restart	-	-	-	-	Restart
3	Fault acknowl. + restart	Fault acknowl. + restart	Fault acknowl. + restart	Fault acknowl. + restart	Fault acknowl. + restart	-
4	Fault acknowl. + restart	Fault acknowl. + restart	-	-	-	-
5	Fault acknowl. + restart	-	Fault acknowl. + restart	-	Fault acknowl. + restart	Restart
6	Fault acknowl. + restart	Fault acknowl. + restart	Fault acknowl. + restart	Fault acknowl. + restart	Fault acknowl. + restart	Restart

Flying start must be used in cases where the motor may still be turning (e.g. after a short mains break) or can be driven by the load (P1200).

P1211	Number of restart attempts	Datatype: U16	Unit: -	Min: 0	Level 3
	CStat: CUT	Active: first confirm	QuickComm.: No	Def: 3	
	P-Group: FUNC			Max: 10	

Specifies number of times inverter will attempt to restart if automatic restart P1210 is activated.

P1212	Time to first restart	Datatype: U16	Unit: s	Min: 0	Level 3
	CStat: CUT	Active: first confirm	QuickComm.: No	Def: 30	
	P-Group: FUNC			Max: 1000	

Selects the time before the inverter is restarted for the first time if automatic restart P1210 is activated.

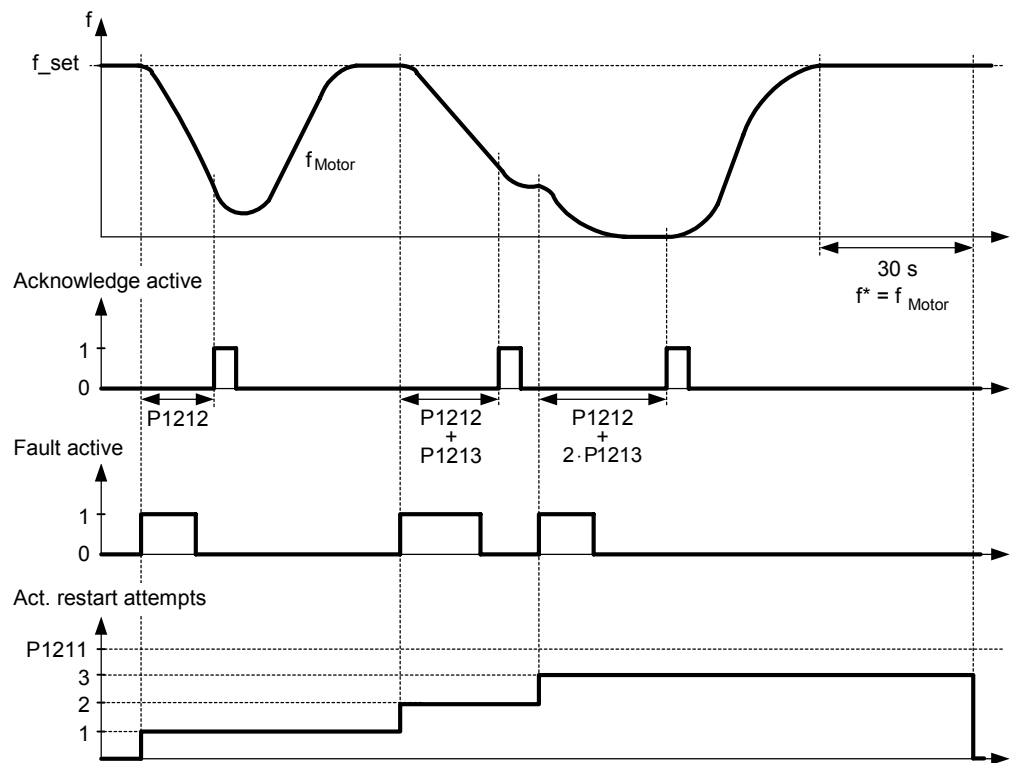

P1213	Restart time increment	Datatype: U16	Unit: s	Min: 0	Level 3
	CStat: CUT	Active: first confirm	QuickComm.: No	Def: 30	
	P-Group: FUNC			Max: 1000	

Selects the amount the restart time is increment for each restart of the inverter if automatic restart P1210 is activated.

3.23 Motor holding brake

P1215	Holding brake enable	Datatype: U16	Unit: -	Min: 0	Level 2
	CStat: T	Active: first confirm	QuickComm.: No	Def: 0	
	P-Group: FUNC			Max: 1	

Enables/disables holding brake function.

This function applies the following profile to the inverter:

ON / OFF1/OFF3:

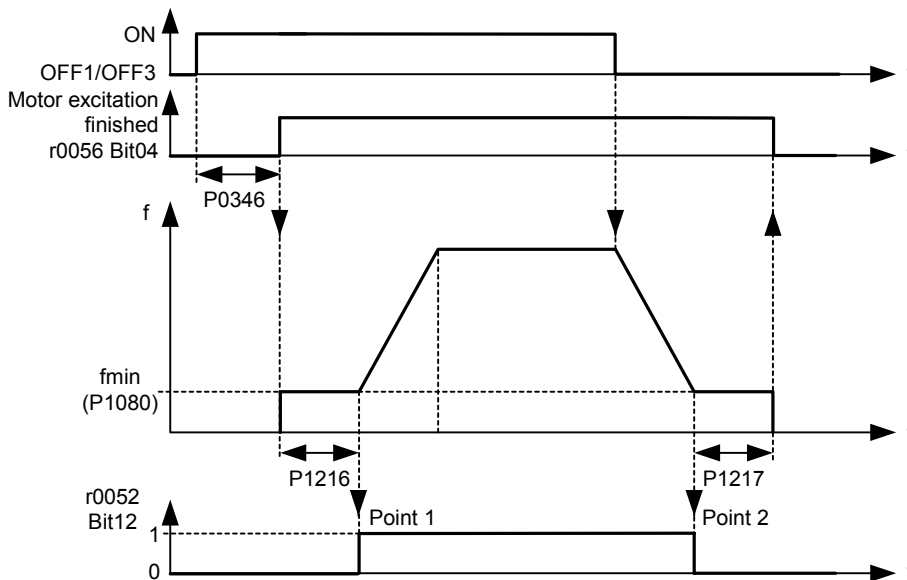

ON / OFF2:

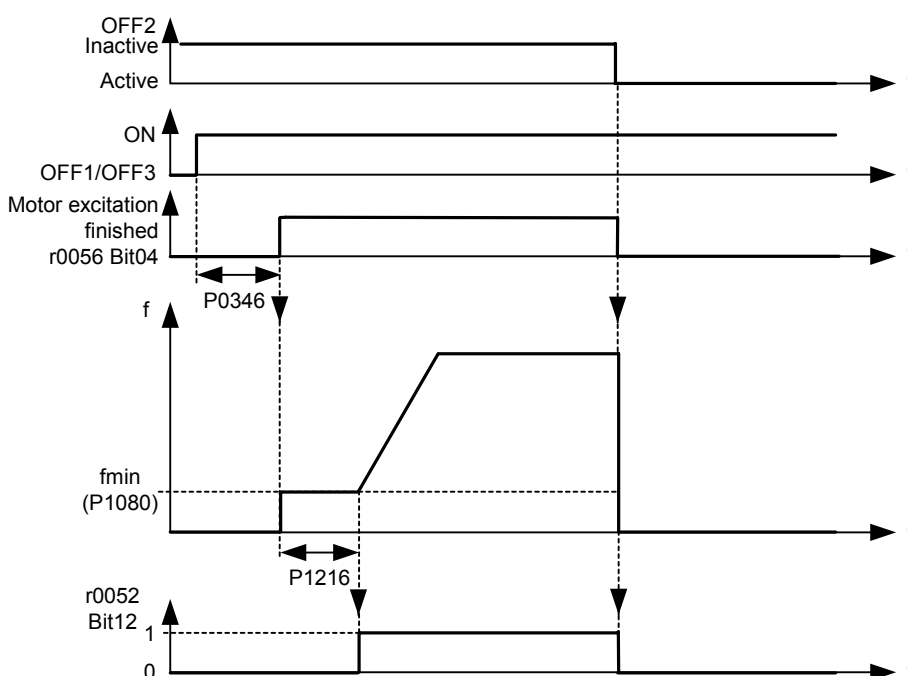

Possible Settings:

- 0 Motor holding brake disabled
- 1 Motor holding brake enabled



Caution:

1. To activate the motor holding brake, in addition to parameter P1215 = 1, the status signal r0052 bit 12 "motor holding brake active" must be output via a digital output. The user must also select the signal - e.g. in parameter P0731.
2. If the motor holding brake is controlled by the drive inverter, then for potentially hazardous loads (e.g. suspended/hanging loads for crane applications) the drive inverter may not be conditioned unless the load has been secured. Before commissioning, potentially hazardous loads can be secured as follows:
 - lower the load to the floor, or
 - during commissioning or after replacing the drive inverter, prevent the drive inverter from controlling the motor holding brake. Only then should STARTER be used to carry-out a quick commissioning or a parameter download, etc. The motor holding brake terminals can then be re-used (for the motor holding brake, in this case, it is not permissible to parameterize the system so that the digital output P0748 is inverted).
3. In order to hold the motor against the mechanical brake at a certain frequency, it is important that the min. frequency P1080 approximately corresponds to the slip frequency.
 - If the value is selected to be too high, then the current drawn can be too high so that the drive inverter trips (shuts down) due to an overcurrent condition.
 - For a low value, it is possible that the torque cannot be established to hold the load.
4. It is not permissible to use the motor holding brake as operating brake as generally it is only designed and dimensioned for a limited number of emergency braking operations.

Note:

Parameter settings:

- To open/close, a digital output controls the motor holding brake at point 1/2 (refer to the diagram). In this case, as prerequisite, the motor holding brake P1215 must be activated as well as the motor holding brake selected at the digital output.
- Brake opening time P1216 greater than/equal to the time for the holding brake to open.
- Brake delay time P1217 greater than/equal to the time to close the holding brake.
- Select the minimum frequency P1080 so that it acts like weight equalization.
- A typical value of the minimum frequency P1080 for the motor holding brake is the slip frequency of the motor r0330. The rated slip frequency can be calculated using the following formula:

$$f_{slip}[\text{Hz}] = \frac{r0330}{100} \cdot P0310 = \frac{n_{syn} - n_n}{n_{syn}} \cdot f_n$$

The following closed-loop control parameters should be observed in conjunction with the motor holding brake:

- P1310, P1311, P1333, P1335 for U/f

P1216	Holding brake release delay	Min: 0.0	Level 2	
	CStat: T	Datatype: Float		Unit: s
	P-Group: FUNC	Active: first confirm		QuickComm.: No
		Def: 1.0		
		Max: 20.0		

Defines the brake opening time of the motor holding brake (MHB).

When the motor holding brake (P1215) is activated, then the setpoint enable is delayed by the selected time. The time that it takes to open the mechanical brake is subject to certain fluctuations. This is the reason that the drive inverter applies the min. frequency P1080 to the motor during this time. This means that the brake can reliably open before the motor starts.

$$P1216 \geq \text{Release time of the brake} + \text{relay opening time(s)}$$

Details:

See parameter P1215.

P1217	Holding time after ramp down	Min: 0.0	Level 2	
	CStat: T	Datatype: Float		Unit: s
	P-Group: FUNC	Active: first confirm		QuickComm.: No
		Def: 1.0		
		Max: 20.0		

Defines the brake delay time of the motor holding brake (MHB).

When the motor holding brake (P1215) is activated, after an off command, the pulse inhibit is delayed by this selected time. The time that it takes to open the mechanical brake is subject to certain fluctuations. This means that after braking to the min. frequency P1080, the motor is held at the minimum frequency for this time. This means that the brake can reliably close before the motor is switched into a no-current condition.

$$P1217 \geq \text{Application time of the brake} + \text{relay closing time}$$

Details:

See parameter P1215.

3.24 DC braking

P1230[3]	BI: Enable DC braking	Datatype: U32	Unit: -	Min: 0:0	Level 3
	CStat: CUT	Active: first confirm	QuickComm.: No	Def: 0:0	
	P-Group: COMMANDS			Max: 4000:0	

Enables DC braking via a signal applied from an external source. Function remains active while external input signal is active.

DC braking causes the motor to stop rapidly by applying a DC braking current (current applied also holds shaft stationary).

When the DC braking signal is applied, the inverter output pulses are blocked and the DC current is not applied until the motor has been sufficiently demagnetized.

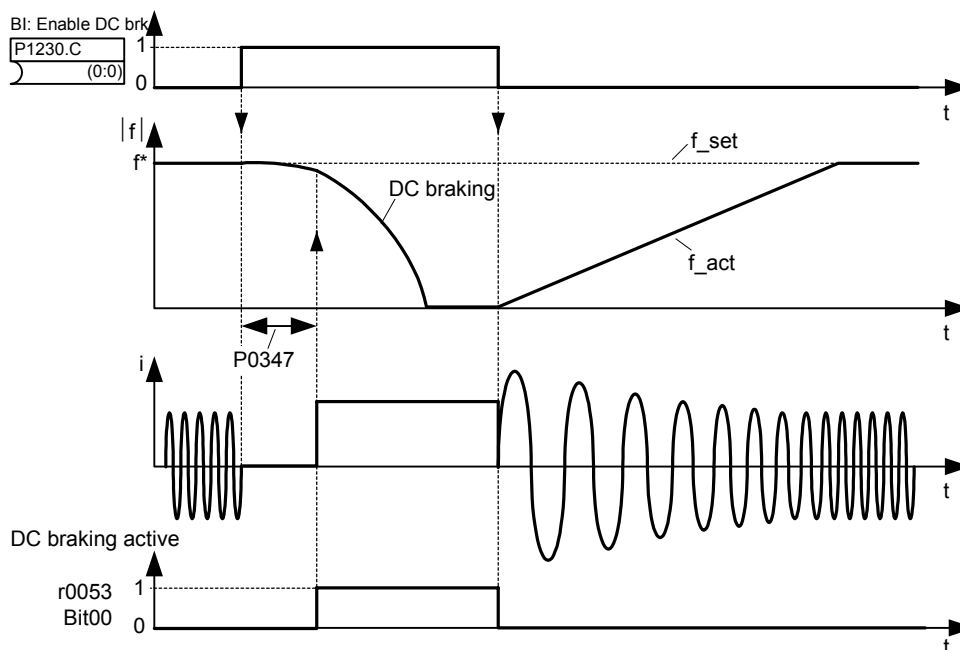

Note: DC brake can be applied in drive states r0002 = 1, 4, 5

The level of DC braking is set in P1232 (DC braking current - relative to the rated motor current) which is set to 100 % by default.

Index:

- P1230[0] : 1st. Command data set (CDS)
- P1230[1] : 2nd. Command data set (CDS)
- P1230[2] : 3rd. Command data set (CDS)

Common Settings:

- 722.0 = Digital input 1 (requires P0701 to be set to 99, BICO)
- 722.1 = Digital input 2 (requires P0702 to be set to 99, BICO)
- 722.2 = Digital input 3 (requires P0703 to be set to 99, BICO)
- 722.3 = Digital input 4 (requires P0704 to be set to 99, BICO)
- 722.4 = Digital input 5 (requires P0705 to be set to 99, BICO)
- 722.5 = Digital input 6 (requires P0706 to be set to 99, BICO)
- 722.6 = Digital input 7 (via analog input 1, requires P0707 to be set to 99)
- 722.7 = Digital input 8 (via analog input 2, requires P0708 to be set to 99)



Caution:

With the DC braking, the kinetic energy of the motor is converted into heat in the motor. The drive could overheat if it remains in this status for an excessive period of time !

DC braking is not possible when using a synchronous motor (i.e. P0300 = 2).

Notice:

This delay time is set in P0347 (demagnetization time). If this delay is too short, overcurrent trips can occur.

P1232[3]	DC braking current	Datatype: U16	Unit: %	Min: 0	Level 3
	CStat: CUT	Active: Immediately	QuickComm.: No	Def: 100	
	P-Group: FUNC			Max: 250	

Defines level of DC current in [%] relative to rated motor current (P0305).

$$r0027_{DC-Brake} [A] = \frac{1}{\sqrt{2}} \cdot P0305 \cdot \frac{P1232}{100 \%}$$

The current of the DC-braking is limited by r0067.

Index:

- P1232[0] : 1st. Drive data set (DDS)
- P1232[1] : 2nd. Drive data set (DDS)
- P1232[2] : 3rd. Drive data set (DDS)

P1233[3]	Duration of DC braking	Datatype: U16	Unit: s	Min: 0	Level 3
	CStat: CUT	Active: Immediately	QuickComm.: No	Def: 0	
	P-Group: FUNC			Max: 250	

Defines duration for which DC injection braking is to be active following an OFF1 or OFF3 command. When an OFF1 or OFF3 command is received by the drive, the output frequency starts to ramp to 0 Hz. When the output frequency reaches the value set in P1234, the drive injects a DC braking current P1232 for the time duration set in P1233.

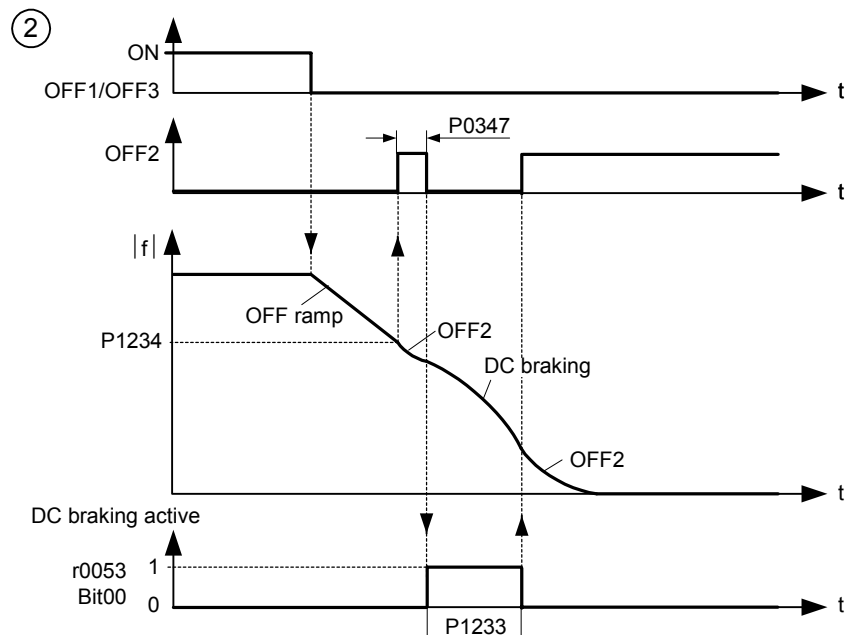
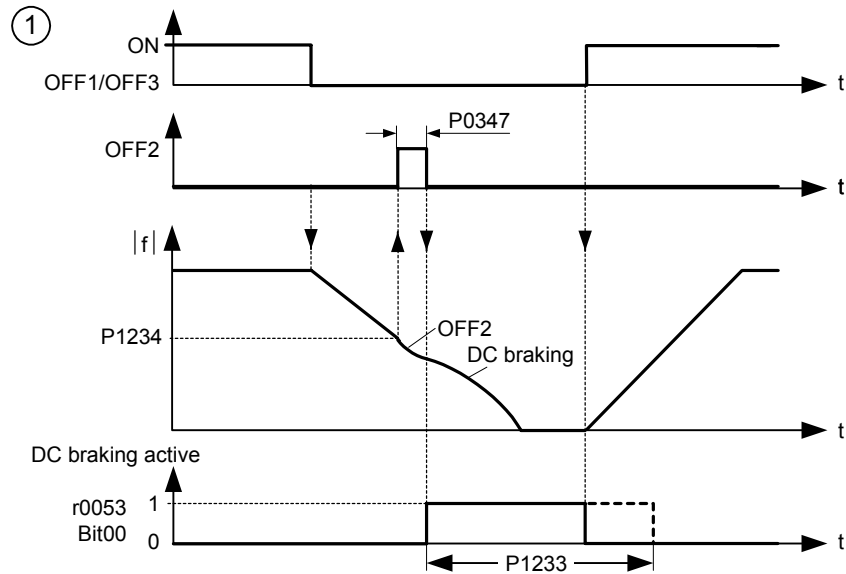

Parameter P1232 still controls the level of DC injection.

Index:

P1233[0] : 1st. Drive data set (DDS)
 P1233[1] : 2nd. Drive data set (DDS)
 P1233[2] : 3rd. Drive data set (DDS)

Value:

P1233 = 0 :
 Not active following OFF1 / OFF3.

P1233 = 1 - 250 :
 Active for the specified duration.



Caution:

With the DC braking, the kinetic energy of the motor is converted into heat in the motor. The drive could overheat if it remains in this status for an excessive period of time !

DC braking is not possible when using a synchronous motor (i.e. P0300 = 2).

Notice:

The DC braking function causes the motor to stop rapidly by applying a DC braking current (the current applied also holds the shaft stationary). When the DC braking signal is applied, the inverter output pulses are blocked and the DC current not applied until the motor has been sufficiently demagnetized (demagnetization time is calculated automatically from motor data).

The inverter will not restart if an ON-command is given during this period.

P1234[3]	DC braking start frequency			Min: 0.00	Level 3
	CStat: CUT	Datatype: Float	Unit: Hz	Def: 650.00	
	P-Group: FUNC	Active: Immediately	QuickComm.: No	Max: 650.00	

Sets start frequency for DC braking.

When an OFF1 or OFF3 command is received by the drive, the output frequency starts to ramp to 0 Hz. When the output frequency reaches the value set in start frequency of DC braking P1234, the drive injects a DC braking current P1232 for the time duration set in P1233.

Index:

P1234[0] : 1st. Drive data set (DDS)
 P1234[1] : 2nd. Drive data set (DDS)
 P1234[2] : 3rd. Drive data set (DDS)

Details:

See P1232 (DC braking current) and P1233 (duration of DC braking)

3.25 Compound braking

P1236[3]	Compound braking current	Min: 0	Level 3	
	CStat: CUT	Datatype: U16		Unit: %
	P-Group: FUNC	Active: Immediately		QuickComm.: No
		Def: 0		
		Max: 250		

Defines DC level superimposed on AC waveform after exceeding DC-link voltage threshold of compound braking. The value is entered in [%] relative to rated motor current (P0305).

If P1254 = 0 :

Compound braking switch-on level

$$U_{DC_Comp} = 1.13 \cdot \sqrt{2} \cdot V_{mains} = 1.13 \cdot \sqrt{2} \cdot P0210$$

otherwise :

Compound braking switch-on level

$$U_{DC_Comp} = 0.98 \cdot r1242$$

The Compound Brake is an overlay of the DC brake function with regenerative braking (effective braking at the ramp) after OFF1 or OFF3. This enables braking with controlled motor frequency and a minimum of energy returned to the motor. Through optimization of the ramp-down time and the compound braking an efficient braking without additional HW components is possible.

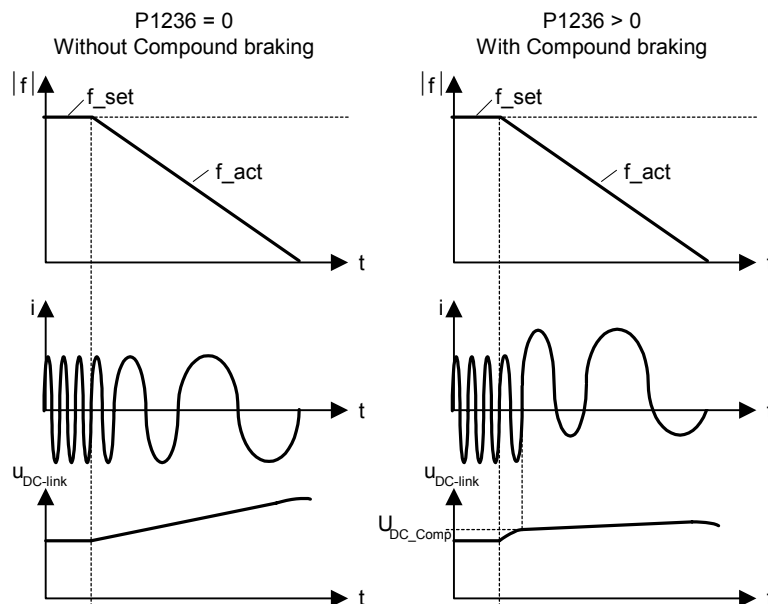

Index:

- P1236[0] : 1st. Drive data set (DDS)
- P1236[1] : 2nd. Drive data set (DDS)
- P1236[2] : 3rd. Drive data set (DDS)

Value:

P1236 = 0 :
Compound braking disabled.

P1236 = 1 - 250 :
Level of DC braking current defined as a [%] of rated motor current (P0305).

Dependency:

Compound braking depends on the DC link voltage only (see threshold above).

It is disabled, when:

- DC braking is active
- Flying start is active

Notice:

Increasing the value will generally improve braking performance; however, if you set the value too high, an overcurrent trip may result.

If used with dynamic braking enabled as well compound braking will take priority.

If used with the Vdc max controller enabled the drive behaviour whilst braking may be worsened particularly with high values of compound braking.

3.26 V/f control

P1240[3]	Configuration of Vdc controller	Min: 0	Level 3
	CStat: CT Datatype: U16 Unit: - Def: 1		
	P-Group: FUNC Active: Immediately QuickComm.: No Max: 1		

Enables / disables Vdc controller.

The Vdc controller dynamically controls the DC link voltage to prevent overvoltage trips on high inertia systems.

Possible Settings:

- 0 Vdc controller disabled
- 1 Vdc-max controller enabled

Index:

- P1240[0] : 1st. Drive data set (DDS)
- P1240[1] : 2nd. Drive data set (DDS)
- P1240[2] : 3rd. Drive data set (DDS)

Note:

Vdc max controller automatically increases ramp-down times to keep the DC-link voltage (r0026) within limits (r1242).

r1242	CO: Switch-on level of Vdc-max	Min: -	Level 3
	Datatype: Float Unit: V Def: -		
	P-Group: FUNC Max: -		

Displays switch-on level of Vdc max controller.

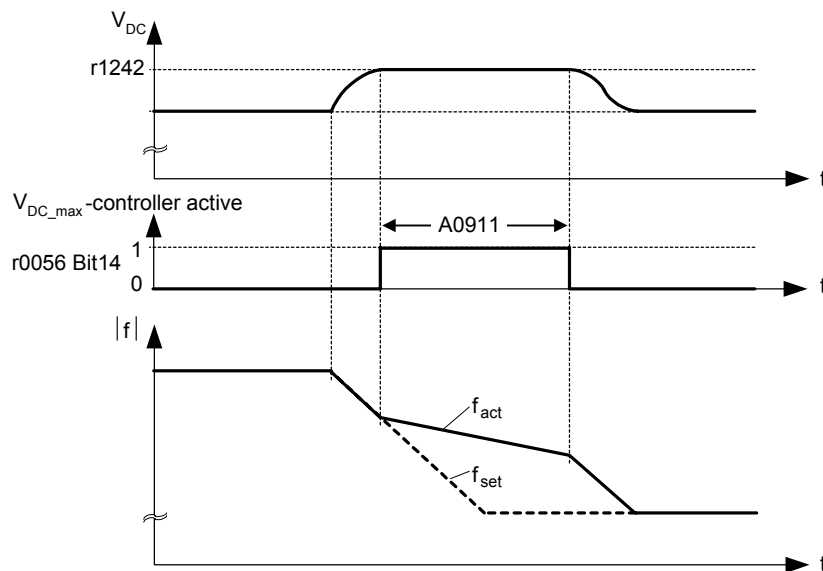

Following equation is only valid, if P1254 = 0 :

$$r1242 = 1.15 \cdot \sqrt{2} \cdot V_{mains} = 1.15 \cdot \sqrt{2} \cdot P0210$$

otherwise :

r1242 is internally calculated

Note:

Parameter r1242 (switch-in threshold) is determined by each power cycle, when precharging of the DC-link is finished.

P1243[3]	Dynamic factor of Vdc-max	Min: 10	Level 3
	CStat: CUT Datatype: U16 Unit: % Def: 100		
	P-Group: FUNC Active: Immediately QuickComm.: No Max: 200		

Defines dynamic factor for DC link controller in [%].

Index:

- P1243[0] : 1st. Drive data set (DDS)
- P1243[1] : 2nd. Drive data set (DDS)
- P1243[2] : 3rd. Drive data set (DDS)

Dependency:

P1243 = 100 % means parameters P1250, P1251 and P1252 (gain, integration time and differential time) are used as set. Otherwise, these are multiplied by P1243 (dynamic factor of Vdc-max).

Note:

Vdc controller adjustment is calculated automatically from motor and inverter data.

P1253[3]	Vdc-controller output limitation				Min: 0.00	Level 3
	CStat: CUT	Datatype: Float	Unit: Hz	Def: 10.00		
	P-Group: FUNC	Active: Immediately	QuickComm.: No	Max: 600.00		

Limits maximum effect of Vdc max controller.

Index:

P1253[0] : 1st. Drive data set (DDS)
P1253[1] : 2nd. Drive data set (DDS)
P1253[2] : 3rd. Drive data set (DDS)

P1254	Auto detect Vdc switch-on levels				Min: 0	Level 3
	CStat: CT	Datatype: U16	Unit: -	Def: 1		
	P-Group: FUNC	Active: Immediately	QuickComm.: No	Max: 1		

Enables/disables auto-detection of switch-on levels for Vdc control functionalities.

Following switch-on levels are calculated

- Switch-on level compound brake
- Switch-on level Vdc_max controller r1242

Possible Settings:

0 Disabled
1 Enabled

Note:

The switch-on thresholds are only calculated during the start-up of the inverter after connection to the mains. An online-adaption is not performed during operation. This means that modification of P1254 does not immediately take effect and variations in the mains are also not initially taken into account.

P1254 = 0 (Automatic Detection disabled):

The above thresholds are calculated via P0210, if automatic detection is disabled.

3.27 Bypass

P1260[3]	Bypass control	Datatype: U16	Unit: -	Min: 0	Level 2
	CStat: CT	Active: first confirm	QuickComm.: No	Def: 0	
	P-Group: FUNC			Max: 7	

Selects the possible sources for contactor changeover control.

Possible Settings:

- 0 Bypass disabled
- 1 Controlled by inverter trip
- 2 Controlled by P1266
- 3 Controlled by P1266 or inverter trip
- 4 Controlled by act. frequenz = P1265
- 5 Controlled by act. frequenz = P1265 or inverter trip
- 6 Controlled by act. frequenz = P1265 or P1266
- 7 Controlled by act. frequenz = P1265 or P1266 or inverter trip

Index:

- P1260[0] : 1st. Drive data set (DDS)
- P1260[1] : 2nd. Drive data set (DDS)
- P1260[2] : 3rd. Drive data set (DDS)

Dependency:

Bypass is used to described the condition when a motor is ran alternatively between a mains supply and the inverter. For example, the bypass circuit can be used to switch over from the inverter to a mains supply when the inverter is faulty. This function can also be used to ramp-up a large rotation mass using the inverter and then, at the correct speed, switching over to the mains supply.

An example of a bypass circuit is given in the following diagram:

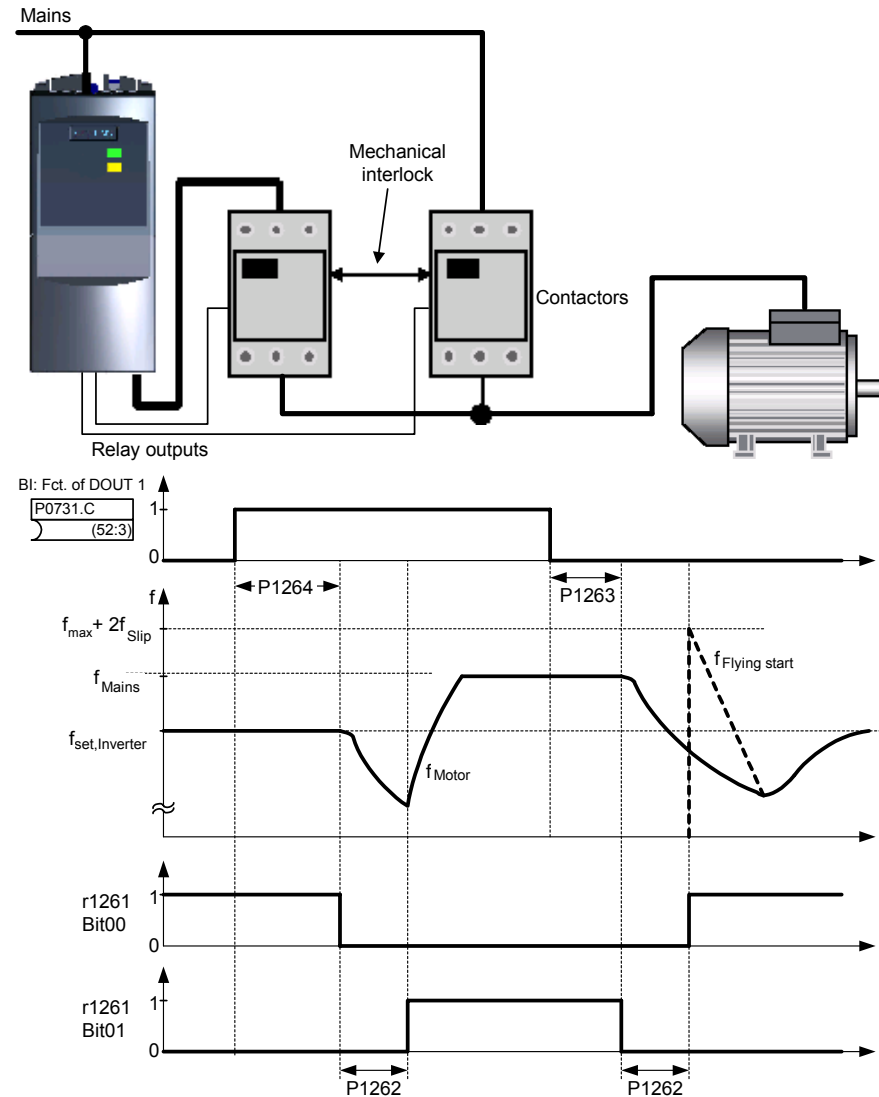

Note:

Flying start P1200 should be enabled in cases where the motor may still be turning after switch-over from bypass-mode to inverter-mode.

r1261	BO: Bypass status word	Datatype: U16	Unit: -	Min: -	Level 2
	P-Group: FUNC			Def: - Max: -	

Output word from the bypass feature that allows external connections to be made.

Bitfields:

Bit00	Motor supplied by inverter	0	NO	1	YES
Bit01	Motor supplied by mains	0	NO	1	YES

P1262[3]	Bypass dead time	Datatype: Float	Unit: s	Min: 0	Level 2
	CStat: CUT	Active: first confirm	QuickComm.: No	Def: 1.000 Max: 20.000	

P1262 is the interlock time between switching one contactor OFF, and the other ON. Its minimum value should not be smaller than the motor demagnetisation time P0347.

Index:

P1262[0] : 1st. Drive data set (DDS)
P1262[1] : 2nd. Drive data set (DDS)
P1262[2] : 3rd. Drive data set (DDS)

P1263[3]	De-Bypass time	Datatype: Float	Unit: s	Min: 0	Level 2
	CStat: CUT	Active: first confirm	QuickComm.: No	Def: 1.0 Max: 300.0	

This delay timer is used as a delay for all sources of switchover from bypass to inverter control.

If the condition for switching from bypass is removed then this timer is reset, and must run through again before bypass will occur.

Index:

P1263[0] : 1st. Drive data set (DDS)
P1263[1] : 2nd. Drive data set (DDS)
P1263[2] : 3rd. Drive data set (DDS)

P1264[3]	Bypass time	Datatype: Float	Unit: s	Min: 0	Level 2
	CStat: CUT	Active: first confirm	QuickComm.: No	Def: 1.0 Max: 300.0	

This delay timer is used as a delay for all sources of switchover from inverter control to bypass.

If the condition for switching to bypass is removed then this timer is reset, and must run through again before bypass will occur.

Index:

P1264[0] : 1st. Drive data set (DDS)
P1264[1] : 2nd. Drive data set (DDS)
P1264[2] : 3rd. Drive data set (DDS)

P1265[3]	Bypass frequency	Datatype: Float	Unit: Hz	Min: 12.00	Level 2
	CStat: CT	Active: first confirm	QuickComm.: No	Def: 50.00 Max: 650.00	

Bypass frequency.

Index:

P1265[0] : 1st. Drive data set (DDS)
P1265[1] : 2nd. Drive data set (DDS)
P1265[2] : 3rd. Drive data set (DDS)

P1266[3]	BI: Bypass command	Datatype: U32	Unit: -	Min: 0:0	Level 2
	CStat: CT	Active: first confirm	QuickComm.: No	Def: 0:0 Max: 4000:0	

Bypass Control P1260 can be controlled by an external switch which is connected to the inverter. The P1266 BI: Bypass command selects the interface (e.g. DIN, USS or CB) from which the signal originates.

Index:

P1266[0] : 1st. Command data set (CDS)
P1266[1] : 2nd. Command data set (CDS)
P1266[2] : 3rd. Command data set (CDS)

Common Settings:

722.0 = Digital input 1 (requires P0701 to be set to 99, BICO)
722.1 = Digital input 2 (requires P0702 to be set to 99, BICO)
722.2 = Digital input 3 (requires P0703 to be set to 99, BICO)
722.3 = Digital input 4 (requires P0704 to be set to 99, BICO)
722.4 = Digital input 5 (requires P0705 to be set to 99, BICO)
722.5 = Digital input 6 (requires P0706 to be set to 99, BICO)
722.6 = Digital input 7 (via analog input 1, requires P0707 to be set to 99)
722.7 = Digital input 8 (via analog input 2, requires P0708 to be set to 99)

3.28 Control mode

P1300[3]	Control mode	Datatype: U16	Unit: -	Min: 0	Level 3
	CStat: CT	Active: first confirm	QuickComm.: Yes	Def: 1	
	P-Group: CONTROL			Max: 23	

Controls relationship between speed of motor and voltage supplied by inverter as illustrated in the diagram below.

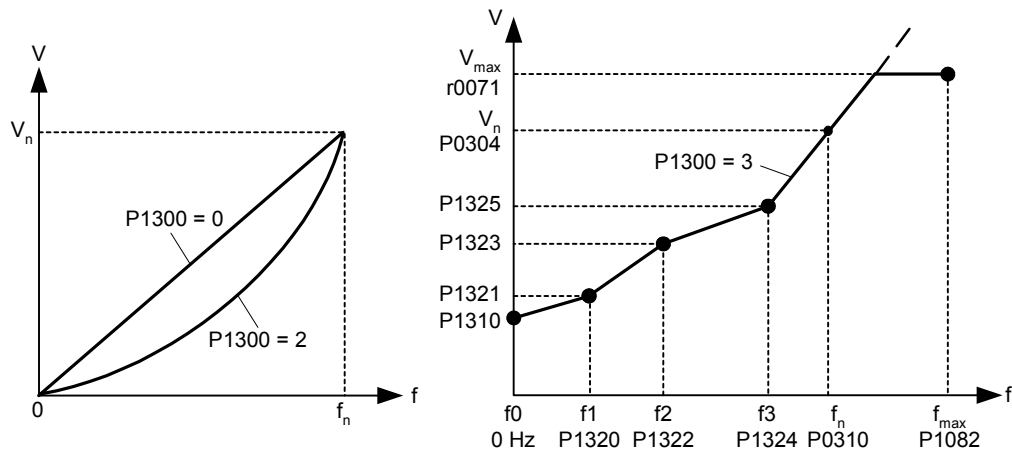

Possible Settings:

- 0 V/f with linear characteristic
- 1 V/f with FCC
- 2 V/f with parabolic characteristic
- 3 V/f with programmable characteristic
- 4 Reserved
- 5 V/f for textile applications
- 6 V/f with FCC for textile applications
- 19 V/f control with independent voltage setpoint
- 20 reserved
- 21 reserved
- 22 reserved
- 23 reserved

Index:

- P1300[0] : 1st. Drive data set (DDS)
- P1300[1] : 2nd. Drive data set (DDS)
- P1300[2] : 3rd. Drive data set (DDS)

Dependency:

See parameter P0205, P0500

Note:

- P1300 = 1 : V/f with FCC (flux current control)
 - Maintains motor flux current for improved efficiency.
 - If FCC is chosen, linear V/f is active at low frequencies.

- P1300 = 2 : V/f with a quadratic characteristic
 - Suitable for centrifugal fans / pumps

- P1300 = 3 : V/f with a programmable characteristic
 - User defined characteristic (see P1320)
 - For synchronous motors (e.g. SIEMOSYN motors)

- P1300 = 5,6 : V/f for textil applications
 - Slip compensation disabled.
 - I_{max} controller modifies the output voltage only.
 - I_{max} controller does not influence the output frequency.

- P1300 = 19 : V/f control with independent voltage setpoint

The following table presents an overview of control parameters (V/f) that can be modify in relationship to P1300 dependencies:

Par No.	Parameter name	Level	V/f						
			P1300 =						
			0	1	2	3	5	6	19
P1300[3]	Control mode	2	x	x	x	x	x	x	x
P1310[3]	Continuous boost	2	x	x	x	x	x	x	x
P1311[3]	Acceleration boost	2	x	x	x	x	x	x	x
P1312[3]	Starting boost	2	x	x	x	x	x	x	x
P1316[3]	Boost end frequency	3	x	x	x	x	x	x	x
P1320[3]	Programmable V/f freq. coord. 1	3	-	-	-	x	-	-	-
P1321[3]	Programmable V/f volt. coord. 1	3	-	-	-	x	-	-	-
P1322[3]	Programmable V/f freq. coord. 2	3	-	-	-	x	-	-	-
P1323[3]	Programmable V/f volt. coord. 2	3	-	-	-	x	-	-	-
P1324[3]	Programmable V/f freq. coord. 3	3	-	-	-	x	-	-	-
P1325[3]	Programmable V/f volt. coord. 3	3	-	-	-	x	-	-	-
P1330[3]	CI: Voltage setpoint	3	-	-	-	-	-	-	x
P1333[3]	Start frequency for FCC	3	-	x	-	-	-	x	-
P1335[3]	Slip compensation	2	x	x	x	x	-	-	-
P1336[3]	CO: U/f Slip limit	2	x	x	x	x	-	-	-
P1338[3]	Resonance damping gain V/f	3	x	x	x	x	-	-	-
P1340[3]	I _{max} freq. controller prop. gain	3	x	x	x	x	x	x	x
P1341[3]	I _{max} controller integral time	3	x	x	x	x	x	x	x
P1345[3]	I _{max} controller prop. gain	3	x	x	x	x	x	x	x
P1346[3]	I _{max} voltage ctrl. integral time	3	x	x	x	x	x	x	x
P1350[3]	Voltage soft start	3	x	x	x	x	x	x	x

P1310[3]	Continuous boost	CStat: CUT	Datatype: Float	Unit: %	Min: 0.0	Level 3
		P-Group: CONTROL	Active: Immediately	QuickComm.: No	Def: 50.0	
					Max: 250.0	

At low output frequencies the output voltage is low to keep the flux level constant. However, the output voltage may be too low

- for magnetisation the asynchronous motor
- to hold the load
- to overcome losses in the system. The output voltage can be increased using parameter P1310.

Defines boost level in [%] relative to P0305 (rated motor current) applicable to both linear and quadratic V/f curves according to the diagram below:

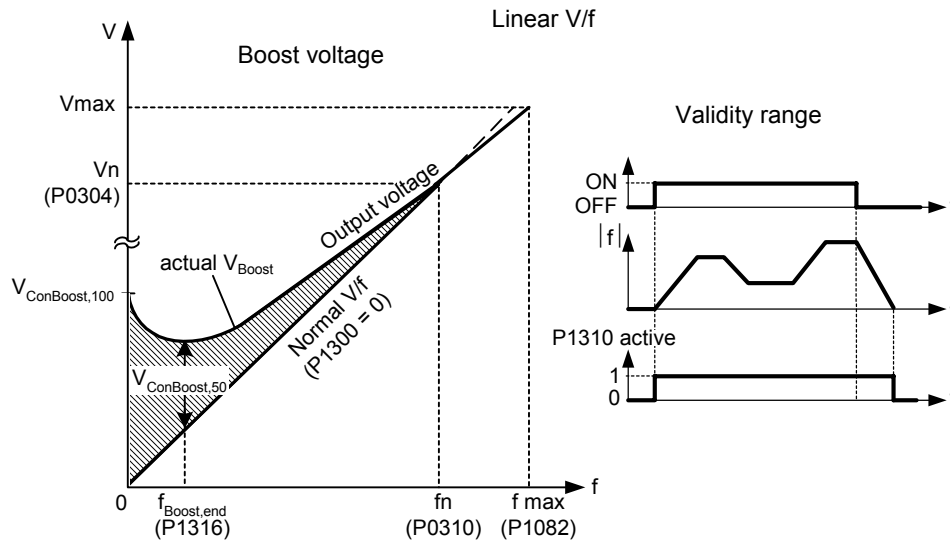

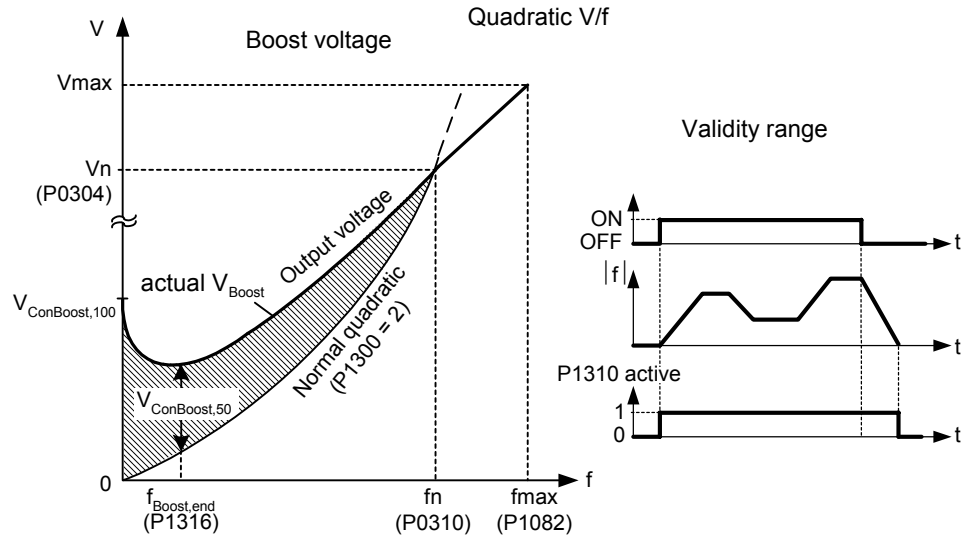

where voltage values are given

$$V_{\text{ConBoost},100} = P0305 \cdot P0350 \cdot \frac{P1310}{100}$$

$$V_{\text{ConBoost},50} = \frac{V_{\text{ConBoost},100}}{2}$$

Index:

- P1310[0] : 1st. Drive data set (DDS)
- P1310[1] : 2nd. Drive data set (DDS)
- P1310[2] : 3rd. Drive data set (DDS)

Note:

- Increasing the boost levels increases motor heating (especially at standstill).
- The boost values are combined when continuous boost (P1310) used in conjunction with other boost parameters (acceleration boost P1311 and starting boost P1312).
- However priorities are allocated to these parameters as follows:
P1310 > P1311 > P1312
- The total boost is limited by following equation:

$$\sum V_{\text{Boost}} \leq 3 \cdot R_s \cdot I_{\text{Mot}} = 3 \cdot P0305 \cdot P0350$$

- Setting in P0640 (motor overload factor [%]) limits the boost:

$$\frac{\sum V_{\text{Boost}}}{P0305 \cdot P0350} \leq \frac{P0640}{100}$$

P1311[3]	Acceleration boost	Datatype: Float	Unit: %	Min: 0.0	Level 3
	CStat: CUT	Active: Immediately	QuickComm.: No	Def: 0.0	
	P-Group: CONTROL			Max: 250.0	

P1311 will only produce boost during ramping, and is therefore useful for additional torque during acceleration and deceleration.

Applies boost in [%] relative to P0305 (rated motor current) following a positive setpoint change and drops back out once the setpoint is reached.

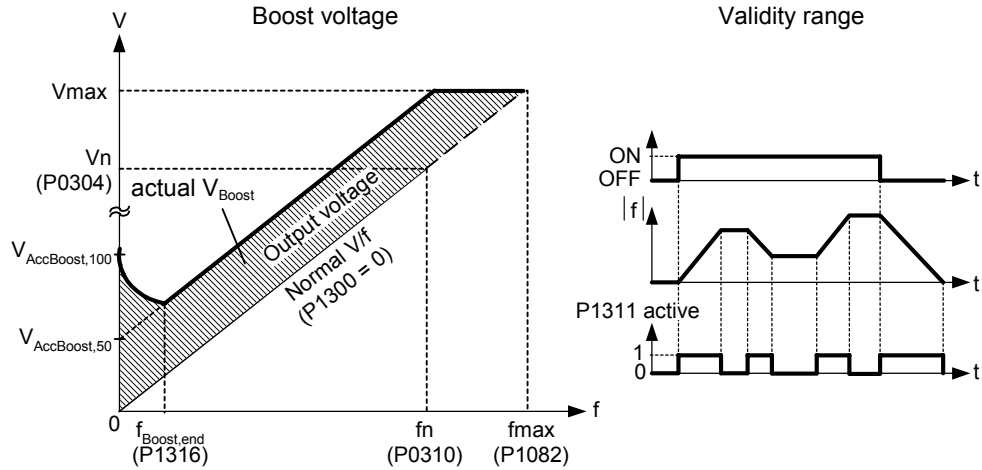

where voltage values are given

$$V_{AccBoost,100} = P0305 \cdot P0350 \cdot \frac{P1311}{100}$$

$$V_{AccBoost,50} = \frac{V_{AccBoost,100}}{2}$$

Index:

- P1311[0] : 1st. Drive data set (DDS)
- P1311[1] : 2nd. Drive data set (DDS)
- P1311[2] : 3rd. Drive data set (DDS)

Note:

See parameter P1310

P1312[3]	Starting boost	Datatype: Float	Unit: %	Min: 0.0	Level 3
	CStat: CUT	Active: Immediately	QuickComm.: No	Def: 0.0	
	P-Group: CONTROL			Max: 250.0	

Applies a constant linear offset (in [%] relative to P0305 (rated motor current)) to active V/f curve (either linear or quadratic) after an ON command and is active until
 1) ramp output reaches setpoint for the first time respectively
 2) setpoint is reduced to less than present ramp output

This is useful for starting loads with high inertia.

Setting the starting boost (P1312) too high will cause the inverter to limit the current, which will in turn restrict the output frequency to below the setpoint frequency.

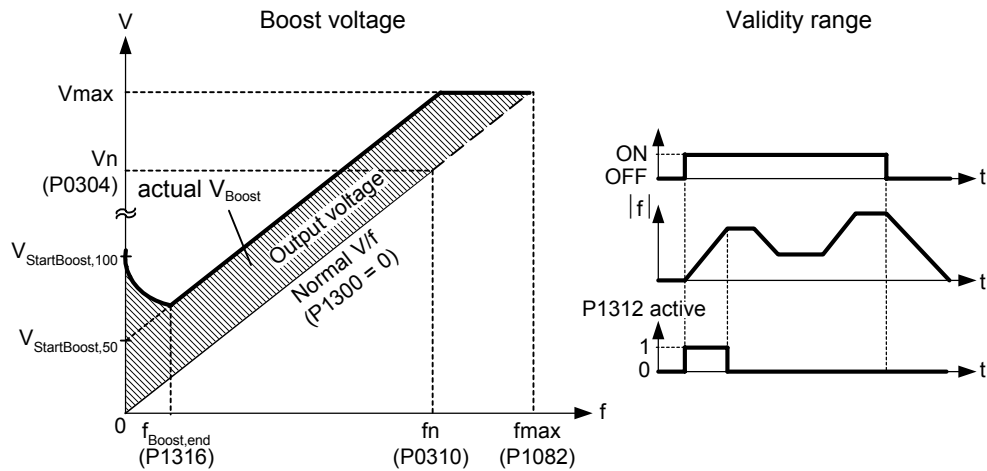

where voltage values are given

$$V_{StartBoost,100} = P0305 \cdot P0350 \cdot \frac{P1312}{100}$$

$$V_{StartBoost,50} = \frac{V_{StartBoost,100}}{2}$$

Index:

- P1312[0] : 1st. Drive data set (DDS)
- P1312[1] : 2nd. Drive data set (DDS)
- P1312[2] : 3rd. Drive data set (DDS)

Example:

Setpoint = 50Hz. Ramping up with starting boost. During ramp up, setpoint changed to 20Hz. As soon as setpoint changed, starting boost removed because setpoint smaller than present ramp output.

Note:

See parameter P1310

P1316[3]	Boost end frequency	Datatype: Float	Unit: %	Min: 0.0	Level 3
	CStat: CUT	Active: Immediately	QuickComm.: No	Def: 20.0	
	P-Group: CONTROL			Max: 100.0	

Defines point at which programmed boost reaches 50 % of its value. This value is expressed in [%] relative to P0310 (rated motor frequency).

The default frequency is defined as follows:

$$f_{Boost\ min} = 2 \cdot \left(\frac{153}{\sqrt{P_{motor}}} + 3 \right)$$

Index:

- P1316[0] : 1st. Drive data set (DDS)
- P1316[1] : 2nd. Drive data set (DDS)
- P1316[2] : 3rd. Drive data set (DDS)

Note:

- The expert user may change this value to alter the shape of the curve, e.g. to increase torque at a particular frequency.
- Default value is depending on inverter type and its rating data.

Details:

See diagram in P1310 (continuous boost).

P1320[3]	Programmable V/f freq. coord. 1				Min: 0.00	Level 3
	CStat: CT	Datatype: Float	Unit: Hz	Def: 0.00		
	P-Group: CONTROL	Active: Immediately	QuickComm.: No	Max: 650.00		

Sets V/f coordinates (P1320/1321 to P1324/1325) to define V/f characteristic.

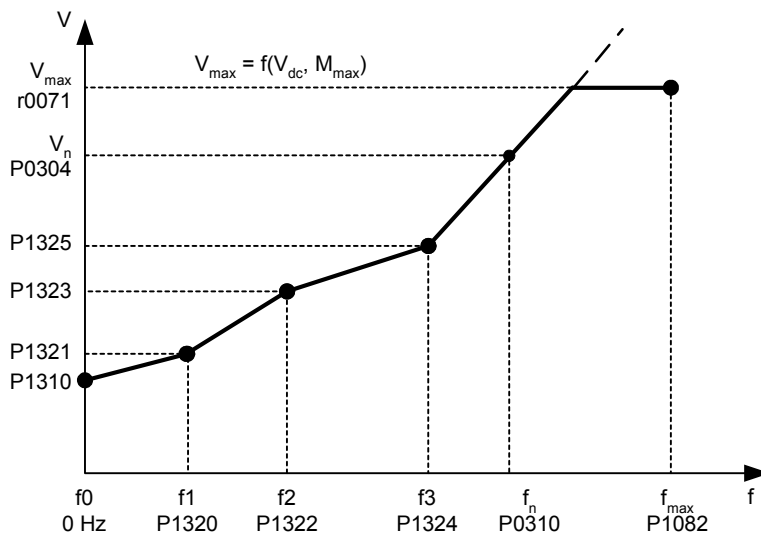

$$P1310[V] = \frac{P1310[\%]}{100[\%]} \cdot \frac{r0395[\%]}{100[\%]} \cdot P0304[V]$$

Index:

- P1320[0] : 1st. Drive data set (DDS)
- P1320[1] : 2nd. Drive data set (DDS)
- P1320[2] : 3rd. Drive data set (DDS)

Example:

This parameter can be used to provide correct torque at correct frequency and is useful when used with synchronous motors.

Dependency:

To set parameter, select P1300 = 3 (V/f with programmable characteristic).

Note:

Linear interpolation will be applied between the individual data points.

V/f with programmable characteristic (P1300 = 3) has 3 programmable points. The two non-programmable points are:

- Continuous boost P1310 at zero 0 Hz
- Rated motor voltage P0304 at rated motor frequency P0310

The acceleration boost and starting boost defined in P1311 and P1312 are applied to V/f with programmable characteristic.

P1321[3]	Programmable V/f volt. coord. 1				Min: 0.0	Level 3
	CStat: CUT	Datatype: Float	Unit: V	Def: 0.0		
	P-Group: CONTROL	Active: Immediately	QuickComm.: No	Max: 3000.0		

See P1320 (programmable V/f freq. coord. 1).

Index:

- P1321[0] : 1st. Drive data set (DDS)
- P1321[1] : 2nd. Drive data set (DDS)
- P1321[2] : 3rd. Drive data set (DDS)

P1322[3]	Programmable V/f freq. coord. 2				Min: 0.00	Level 3
	CStat: CT	Datatype: Float	Unit: Hz	Def: 0.00		
	P-Group: CONTROL	Active: Immediately	QuickComm.: No	Max: 650.00		

See P1320 (programmable V/f freq. coord. 1).

Index:

- P1322[0] : 1st. Drive data set (DDS)
- P1322[1] : 2nd. Drive data set (DDS)
- P1322[2] : 3rd. Drive data set (DDS)

P1323[3]	Programmable V/f volt. coord. 2	Min: 0.0	Level 3
	CStat: CUT Datatype: Float Unit: V Def: 0.0		
	P-Group: CONTROL Active: Immediately QuickComm.: No Max: 3000.0		

See P1320 (programmable V/f freq. coord. 1).

Index:

- P1323[0] : 1st. Drive data set (DDS)
- P1323[1] : 2nd. Drive data set (DDS)
- P1323[2] : 3rd. Drive data set (DDS)

P1324[3]	Programmable V/f freq. coord. 3	Min: 0.00	Level 3
	CStat: CT Datatype: Float Unit: Hz Def: 0.00		
	P-Group: CONTROL Active: Immediately QuickComm.: No Max: 650.00		

See P1320 (programmable V/f freq. coord. 1).

Index:

- P1324[0] : 1st. Drive data set (DDS)
- P1324[1] : 2nd. Drive data set (DDS)
- P1324[2] : 3rd. Drive data set (DDS)

P1325[3]	Programmable V/f volt. coord. 3	Min: 0.0	Level 3
	CStat: CUT Datatype: Float Unit: V Def: 0.0		
	P-Group: CONTROL Active: Immediately QuickComm.: No Max: 3000.0		

See P1320 (programmable V/f freq. coord. 1).

Index:

- P1325[0] : 1st. Drive data set (DDS)
- P1325[1] : 2nd. Drive data set (DDS)
- P1325[2] : 3rd. Drive data set (DDS)

P1330[3]	CI: Voltage setpoint	Min: 0:0	Level 3
	CStat: T Datatype: U32 Unit: - Def: 0:0		
	P-Group: CONTROL Active: first confirm QuickComm.: No Max: 4000:0		

BICO parameter for selecting source of voltage setpoint for independent V/f control.

Index:

- P1330[0] : 1st. Command data set (CDS)
- P1330[1] : 2nd. Command data set (CDS)
- P1330[2] : 3rd. Command data set (CDS)

P1333[3]	Start frequency for FCC	Min: 0.0	Level 3
	CStat: CUT Datatype: Float Unit: % Def: 10.0		
	P-Group: CONTROL Active: Immediately QuickComm.: No Max: 100.0		

Defines the FCC starting frequency as a percentage of the rated motor frequency (P0310).

When FCC is activated using P1300 = 1, then as a function of the FCC starting frequency plus hysteresis and the actual frequency, a changeover is made with a continuous transition between the linear V/f characteristic (P1300 = 0) and FCC (refer to the diagram).

$$f_{FCC} = \frac{P0310}{100} \cdot P1333$$

$$f_{FCC+Hys} = \frac{P0310}{100} \cdot (P1333 + 6\%)$$

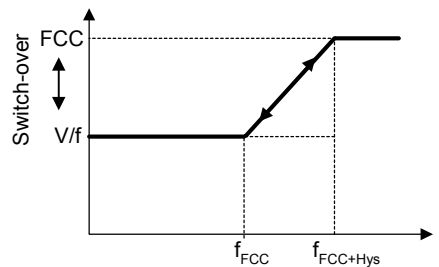

Index:

- P1333[0] : 1st. Drive data set (DDS)
- P1333[1] : 2nd. Drive data set (DDS)
- P1333[2] : 3rd. Drive data set (DDS)

Notice:

- A value that is excessively low can result in instability.
- The constant voltage boost P1310 is continuously de-activated - essentially the same as when switching-in FCC.
- Contrary, the voltage boosts P1311 and P1312 remain active over the complete frequency range.

3.28.1 Slip compensation

P1335[3]	Slip compensation	Datatype: Float	Unit: %	Min: 0.0	Level 3
	CStat: CUT	Active: Immediately	QuickComm.: No	Def: 0.0	
	P-Group: CONTROL			Max: 600.0	

Dynamically adjusts output frequency of inverter so that motor speed is kept constant independent of motor load.

In the V/f-control, the motor speed will always be less than the command speed due to the slip speed. For a given speed command, the speed will drop as load is increased. The speed regulation of drive can be improved by the technique known as slip compensation.

Increasing the load from M1 to M2 (see diagram) will decrease the motor speed from f1 to f2, due to the slip. The inverter can compensate for this by increasing the output frequency slightly as the load increases. The inverter measures the current and increases the output frequency to compensate for the expected slip.

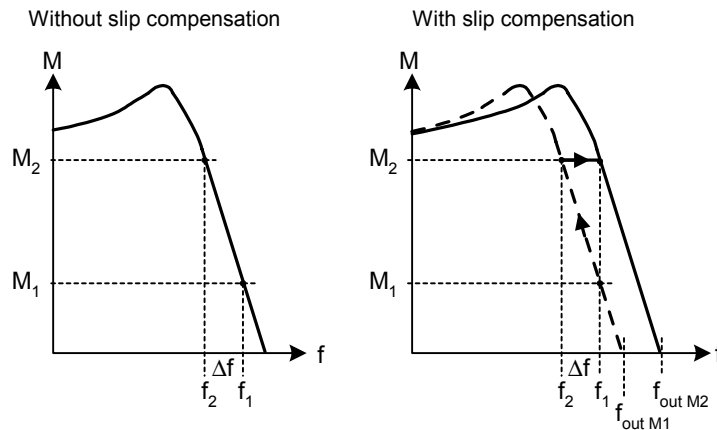

Index:

- P1335[0] : 1st. Drive data set (DDS)
- P1335[1] : 2nd. Drive data set (DDS)
- P1335[2] : 3rd. Drive data set (DDS)

Value:

- P1335 = 0 % : Slip compensation disabled.
- P1335 = 50 % - 70 % : Full slip compensation at cold motor (partial load).
- P1335 = 100 % : Full slip compensation at warm motor (full load).

Range of slip compensation :

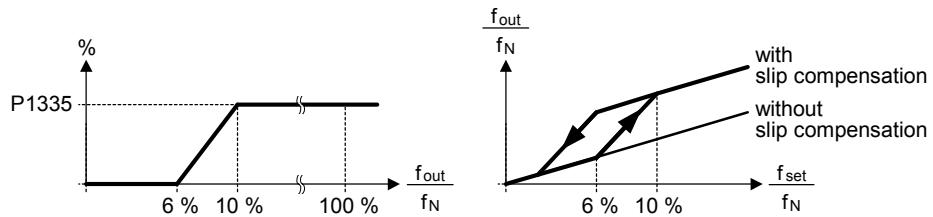

Notice:

The applied value of the slip compensation (scaled by P1335) is limited by following equation:

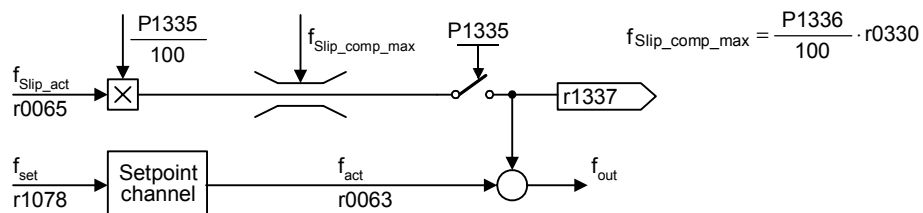

P1336[3]	Slip limit	Min: 0	Level
	CStat: CUT	Datatype: U16	Def: 250
	P-Group: CONTROL	Active: Immediately	QuickComm.: No
		Max: 600	3

Compensation slip limit in [%] relative to r0330 (rated motor slip), which is added to frequency setpoint.

Index:

- P1336[0] : 1st. Drive data set (DDS)
- P1336[1] : 2nd. Drive data set (DDS)
- P1336[2] : 3rd. Drive data set (DDS)

Dependency:

Slip compensation (P1335) active.

r1337	CO: V/f slip frequency	Min: -	Level
		Datatype: Float	Def: -
	P-Group: CONTROL	Unit: %	QuickComm.: -
		Max: -	3

Displays actual compensated motor slip as [%]

Dependency:

Slip compensation (P1335) active.

3.28.2 Resonance damping

P1338[3]	Resonance damping gain V/f	Min: 0.00	Level
	CStat: CUT	Datatype: Float	Def: 0.00
	P-Group: CONTROL	Active: Immediately	QuickComm.: No
		Max: 10.00	3

Defines resonance damping gain for V/f. Here, di/dt of the active current will be scaled by P1338 (see diagram below). If di/dt increases the resonance damping circuit decreases the inverter output frequency.

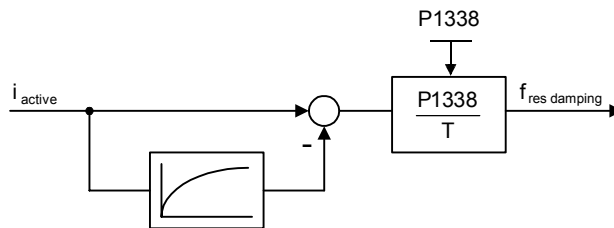

Index:

- P1338[0] : 1st. Drive data set (DDS)
- P1338[1] : 2nd. Drive data set (DDS)
- P1338[2] : 3rd. Drive data set (DDS)

Note:

- The resonance damping function is used to dampen oscillations in the active current. These especially occur when rotating field motors are operating under no-load conditions. The parameter is not used to optimize the stabilizing behavior.
- In the V/f control modes (refer to P1300), the resonance damping controller is activate in a range from approximately 5 % up to 70 % of the rated motor frequency (P0310).
- An excessively high value results in instability (positive feedback).

3.28.3 I_{max} controller

P1340[3]	I_{max} freq. controller prop. gain				Min: 0.000	Level 3
	CStat: CUT	Datatype: Float	Unit: -	Def: 0.000		
	P-Group: CONTROL	Active: Immediately	QuickComm.: No	Max: 0.499		

Proportional gain of the I_{max} frequency controller.

The I_{max} controller reduces inverter current if the output current exceeds the maximum motor current (r0067).

In linear V/f, parabolic V/f, FCC, and programmable V/f modes the I_{max} controller uses both a frequency controller (see parameters P1340 and P1341) and a voltage controller (see parameters P1345 and P1346). The frequency controller seeks to reduce current by limiting the inverter output frequency (to a minimum of the two times nominal slip frequency). If this action does not successfully remove the overcurrent condition, the inverter output voltage is reduced using the I_{max} voltage controller. When the overcurrent condition has been removed successfully, frequency limiting is removed using the ramp-up time set in P1120.

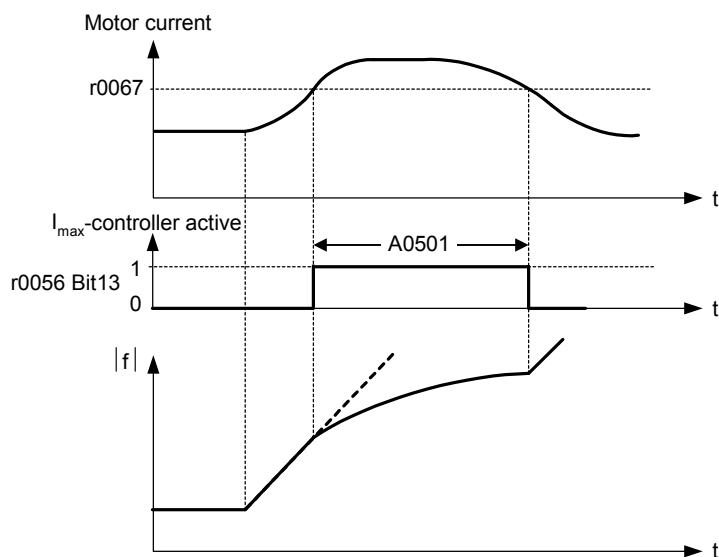

In linear V/f for textiles, FCC for textiles, or external V/f modes only the I_{max} voltage controller is used to reduce current (See parameters P1345 and P1346).

Index:

- P1340[0] : 1st. Drive data set (DDS)
- P1340[1] : 2nd. Drive data set (DDS)
- P1340[2] : 3rd. Drive data set (DDS)

Note:

The I_{max} controller can be disabled by setting the frequency controller integral time P1341 to zero. This disables both the frequency and voltage controllers. Note that when disabled, the I_{max} controller will take no action to reduce current but overcurrent warnings will still be generated, and the Drive will trip in excessive overcurrent or overload conditions.

P1341[3]	I_{max} freq. ctrl. integral time				Min: 0.000	Level 3
	CStat: CUT	Datatype: Float	Unit: s	Def: 0.300		
	P-Group: CONTROL	Active: Immediately	QuickComm.: No	Max: 50.000		

Integral time constant of the I_{max} controller.

P1341 = 0 :
I_{max} frequency and voltage controllers disabled

P1340 = 0 and P1341 > 0 :
frequency controller enhanced integral

P1340 > 0 and P1341 > 0 :
frequency controller normal PI control

See description in parameter P1340 for further information.

Index:

- P1341[0] : 1st. Drive data set (DDS)
- P1341[1] : 2nd. Drive data set (DDS)
- P1341[2] : 3rd. Drive data set (DDS)

r1343	CO: I_{max} controller freq. output	Datatype: Float	Unit: Hz	Min: -	Level 3
	P-Group: CONTROL			Def: - Max: -	
Displays effective frequency limitation.					
Dependency: If I _{max} controller not in operation, parameter normally shows max. frequency P1082.					
r1344	CO: I_{max} controller volt. output	Datatype: Float	Unit: V	Min: -	Level 3
	P-Group: CONTROL			Def: - Max: -	
Displays amount by which the I _{max} controller is reducing the inverter output voltage.					
P1345[3]	I_{max} voltage ctrl. prop. gain	Datatype: Float	Unit: -	Min: 0.000	Level 3
	CStat: CUT			Def: 0.250	
	P-Group: CONTROL	Active: Immediately	QuickComm.: No	Max: 5.499	
Proportional gain of the I _{max} voltage controller. See parameter P1340 for further information.					
Index: P1345[0] : 1st. Drive data set (DDS) P1345[1] : 2nd. Drive data set (DDS) P1345[2] : 3rd. Drive data set (DDS)					
P1346[3]	I_{max} voltage ctrl. integral time	Datatype: Float	Unit: s	Min: 0.000	Level 3
	CStat: CUT			Def: 0.300	
	P-Group: CONTROL	Active: Immediately	QuickComm.: No	Max: 50.000	
Integral time constant of the I _{max} voltage controller.					
P1341 = 0 : I _{max} frequency and voltage controllers disabled.					
P1345 = 0 and P1346 > 0 : I _{max} voltage controller enhanced integral					
P1345 > 0 and P1346 > 0 : I _{max} voltage controller normal PI control					
See description in parameter P1340 for further information.					
Index: P1346[0] : 1st. Drive data set (DDS) P1346[1] : 2nd. Drive data set (DDS) P1346[2] : 3rd. Drive data set (DDS)					

3.28.4 Soft starting

P1350[3]	Voltage soft start	Datatype: U16	Unit: -	Min: 0	Level 3
	CStat: CUT	Active: first confirm	QuickComm.: No	Def: 0	
	P-Group: CONTROL			Max: 1	

Selection of the voltage soft start function.

For smooth starting, the flux in the motor is established with some delay. This is to ensure that even with residual magnetization, the motor only rotates in the required direction of rotation.

Sets whether boost voltage is built up smoothly during magnetization time after the ON-command (P1350 = 1) or whether it simply jumps to boost voltage (P1350 = 0).

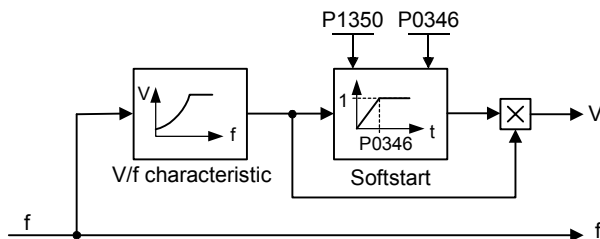

Possible Settings:

- 0 OFF
- 1 ON

Index:

- P1350[0] : 1st. Drive data set (DDS)
- P1350[1] : 2nd. Drive data set (DDS)
- P1350[2] : 3rd. Drive data set (DDS)

Note:

The settings for this parameter bring benefits and drawbacks:

- P1350 = 0: (jump to boost voltage)
Benefit: flux is built up quickly
Drawback: motor may move
- P1350 = 1: (smooth voltage build-up)
Benefit: motor less likely to move
Drawback: flux build-up takes longer

3.29 Inverter parameters (Modulator)

P1800	Pulse frequency	Datatype: U16	Unit: kHz	Min: 2	Level 2
	CStat: CUT	Active: Immediately	QuickComm.: No	Def: 4	
	P-Group: INVERTER			Max: 16	

Sets pulse frequency of power switches in inverter. The frequency can be changed in steps of 2 kHz.

Dependency:

- Minimum pulse frequency depends on P1082 (maximum frequency) and P0310 (rated motor frequency).
- see derating in P1082
- $P1800 > 30 * P0310$

Note:

- If the pulse frequency is increased, max. inverter current r0209 can be reduced (derating). The derating characteristic depends on the type and power of the inverter (see manual OPERATING INSTRUCTION).
- If silent operation is not absolutely necessary, lower pulse frequencies may be selected to reduce inverter losses and radio-frequency emissions.
- Under certain circumstances, the inverter may reduce the switching frequency to provide protection against over-temperature (see P0290).

r1801	CO: Act. pulse frequency	Datatype: U16	Unit: kHz	Min: -	Level 3
	P-Group: INVERTER			Def: -	
				Max: -	

Actual pulse frequency of power switches in inverter.

Notice:

Under certain conditions (inverter overtemperature, see P0290), this can differ from the values selected in P1800 (pulse frequency).

P1802	Modulator mode	Min: 0	Level 3	
	CStat: CUT	Datatype: U16		Unit: -
	P-Group: INVERTER	Active: first confirm		QuickComm.: No

Selects inverter modulator mode.

Possible Settings:

- 0 SVM/ASVM automatic mode
- 1 Asymmetric SVM
- 2 Space vector modulation
- 3 SVM/ASVM controlled mode

Notice:

- Asymmetric space vector modulation (ASVM) produces lower switching losses than space vector modulation (SVM), but may cause irregular rotation at very low frequencies.
- Space vector modulation (SVM) with over-modulation may produce current waveform distortion at high output voltages.
- Space vector modulation (SVM) without over-modulation will reduce maximum output voltage available to motor.

P1820[3]	Reverse output phase sequence	Min: 0	Level 3	
	CStat: CT	Datatype: U16		Unit: -
	P-Group: INVERTER	Active: first confirm		QuickComm.: No

Changes direction of motor rotation without changing setpoint polarity.

Possible Settings:

- 0 OFF
- 1 ON

Index:

- P1820[0] : 1st. Drive data set (DDS)
- P1820[1] : 2nd. Drive data set (DDS)
- P1820[2] : 3rd. Drive data set (DDS)

Dependency:

If positive and negative revolution is enabled, frequency setpoint is directly used.
If both positive and negative revolution are disabled, reference value is set to zero.

Details:

See P1000 (select frequency setpoint)

3.30 Motor data identification

P1910	Select motor data identification	Min: 0	Level 3	
	CStat: CT	Datatype: U16		Unit: -
	P-Group: MOTOR	Active: first confirm		QuickComm.: Yes

Performs a motor data identification.

Performs stator resistance measuring.

Possible Settings:

- 0 Disabled
- 1 Identification of Rs with parameter change
- 2 Identification of Rs without parameter change
- 20 Set voltage vector

Dependency:

No measurement if motor data incorrect.

P1910 = 1 : Calculated value for stator resistance (see P0350) is overwritten.

P1910 = 2 : Values already calculated are not overwritten.

Note:

Before selecting motor data identification, "Quick commissioning" has to be performed in advance.

Once enabled (P1910 = 1), A0541 generates a warning that the next ON command will initiate measurement of motor parameters.

Notice:

When choosing the setting for measurement, observe the following:

1. "with parameter change"
means that the value is actually adopted as P0350 parameter setting and applied to the control as well as being shown in the read-only parameters below.
2. "without parameter change"
means that the value is only displayed, i.e. shown for checking purposes in the read-only parameter r1912 (identified stator resistance). The value is not applied to the control.

P1911	No. of phase to be identified	Min: 1	Level 3	
	CStat: CT	Datatype: U16		Unit: -
	P-Group: INVERTER	Active: Immediately		QuickComm.: No

Selects maximum number of motor phases to be identified.

r1912[3]	Identified stator resistance	Min: -	Level 3	
		Datatype: Float		Unit: Ohm
	P-Group: MOTOR			Def: - Max: -

Displays measured stator resistance value (line-to-line) in [Ohms]

Index:

- r1912[0] : U_phase
- r1912[1] : V_phase
- r1912[2] : W_phase

Note:

This value is measured using P1910 = 1 or 2 , i.e., identification of all parameters with/without change.

r1925	Identified on-state voltage	Min: -	Level 3	
		Datatype: Float		Unit: V
	P-Group: INVERTER			Def: - Max: -

Displays identified on-state voltage of IGBT.

r1926	Ident. gating unit dead time	Min: -	Level 3	
		Datatype: Float		Unit: us
	P-Group: INVERTER			Def: - Max: -

Displays identified dead time of gating unit interlock.

3.31 Reference parameters

P2000[3]	Reference frequency	Min: 1.00	Level 2	
	CStat: CT	Datatype: Float		Unit: Hz
	P-Group: COMM	Active: first confirm		QuickComm.: No

Parameter P2000 represents the reference frequency for frequency values which are displayed/transferred as a percentage or a hexadecimal value. Where:

- hexadecimal 4000 H ==> P2000 (e.g.: USS-PZD)
- percentage 100 % ==> P2000 (e.g.: ADC)

Index:

- P2000[0] : 1st. Drive data set (DDS)
- P2000[1] : 2nd. Drive data set (DDS)
- P2000[2] : 3rd. Drive data set (DDS)

Example:

If a BICO connection is made between two parameters or alternatively using P0719 or P1000, the 'unit' of the parameters (standardized (Hex) or physical (i.e. Hz) values) may differ. MICROMASTER implicitly makes an automatic conversion to the target value.

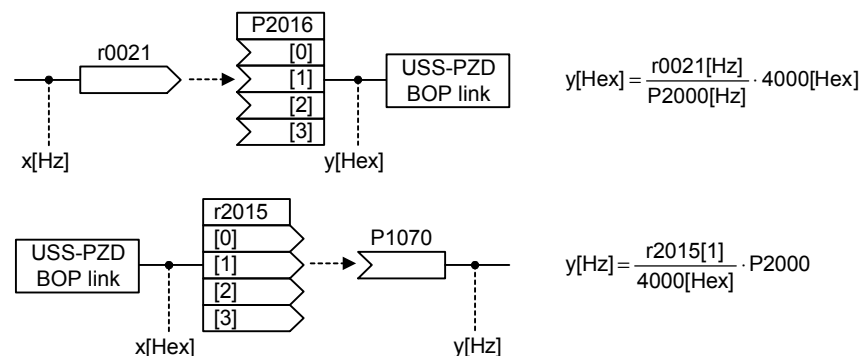



Caution:

Parameter P2000 represents the reference frequency of the above mentioned interfaces. A maximum frequency setpoint of 2*P2000 can be applied via the corresponding interface. Unlike parameter P1082 (Max. Frequency) this limits the inverter frequency internally independent of the reference frequency. By modification of P2000 it will also adapt the parameter to the new settings.

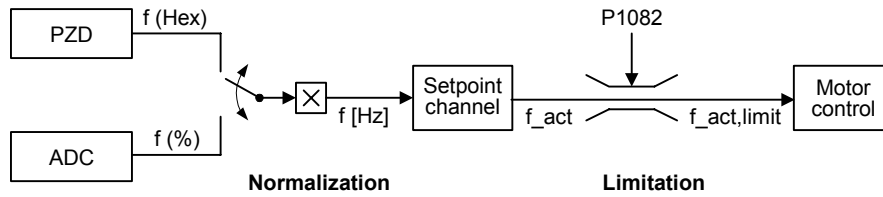

$$f[\text{Hz}] = \frac{f(\text{Hex})}{4000(\text{Hex})} \cdot P2000 = \frac{f(\%)}{100\%} \cdot P2000$$

$$f_{\text{act,limit}} = \min(P1082, f_{\text{act}})$$

Notice:

Reference variables are intended as an aid to presenting setpoint and actual value signals in a uniform manner. This also applies to fixed settings entered as a percentage. A value of 100 % (USS / CB) corresponds to a process data value of 4000H, or 4000 0000H in the case of double values.

In this respect, the following parameters are available:

P2000	Reference frequency	Hz
P2001	Reference voltage	V
P2002	Reference current	A
P2003	Reference torque	Nm
P2004	Reference power	kW hp

— f(P0100)

P2001[3]	Reference voltage	Min: 10	Level
	CStat: CT	Datatype: U16	Unit: V
	P-Group: COMM	Active: first confirm	QuickComm.: No
		Def: 1000	3
		Max: 2000	

Full-scale output voltage (i.e. 100 %) used over serial link (corresponds to 4000H).

Index:

- P2001[0] : 1st. Drive data set (DDS)
- P2001[1] : 2nd. Drive data set (DDS)
- P2001[2] : 3rd. Drive data set (DDS)

Example:

P2001 = 230 specifies that 4000H received via USS denotes 230 V.

If a BICO connection is made between two parameters, the 'unit' of the parameters (standardized (Hex) or physical (i.e. V) values) may differ. MICROMASTER implicitly makes an automatic conversion to the target value.

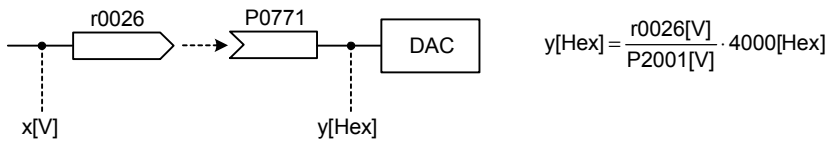

P2002[3]	Reference current	Datatype: Float	Unit: A	Min: 0.10	Level 3
	CStat: CT	Active: first confirm	QuickComm.: No	Def: 0.10	
	P-Group: COMM			Max: 10000.00	

Full-scale output current used over serial link (corresponds to 4000H).

Index:

- P2002[0] : 1st. Drive data set (DDS)
- P2002[1] : 2nd. Drive data set (DDS)
- P2002[2] : 3rd. Drive data set (DDS)

Example:

If a BICO connection is made between two parameters, the 'unit' of the parameters (standardized (Hex) or physical (i.e. A) values) may differ. MICROMASTER implicitly makes an automatic conversion to the target value.

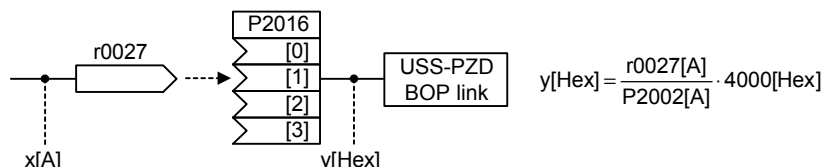

P2003[3]	Reference torque	Datatype: Float	Unit: Nm	Min: 0.10	Level 3
	CStat: CT	Active: first confirm	QuickComm.: No	Def: 0.12	
	P-Group: COMM			Max: 99999.00	

Full-scale reference torque used over the serial link (corresponds to 4000H).

Index:

- P2003[0] : 1st. Drive data set (DDS)
- P2003[1] : 2nd. Drive data set (DDS)
- P2003[2] : 3rd. Drive data set (DDS)

Example:

If a BICO connection is made between two parameters or alternatively using P1500, the 'unit' of the parameters (standardized (Hex) or physical (i.e. Nm) values) may differ. MICROMASTER implicitly makes an automatic conversion to the target value.

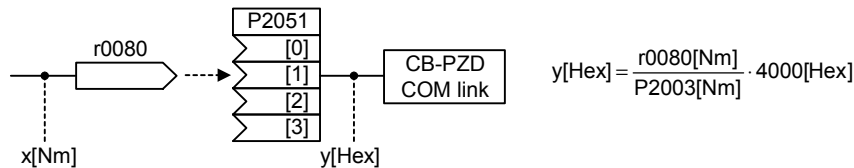

r2004[3]	Reference power	Datatype: Float	Unit: -	Min: -	Level 3
	P-Group: COMM			Def: -	
				Max: -	

Full-scale reference power used over the serial link (corresponds to 4000H).

$$r2004 = \frac{1}{2} \cdot 2 \cdot \pi \cdot f \cdot M = \pi \cdot P2000 \cdot P2003$$

Index:

- r2004[0] : 1st. Drive data set (DDS)
- r2004[1] : 2nd. Drive data set (DDS)
- r2004[2] : 3rd. Drive data set (DDS)

Example:

If a BICO connection is made between two parameters, the 'unit' of the parameters (standardized (Hex) or physical (i.e. kW / hp) values) may differ. MICROMASTER implicitly makes an automatic conversion to the target value.

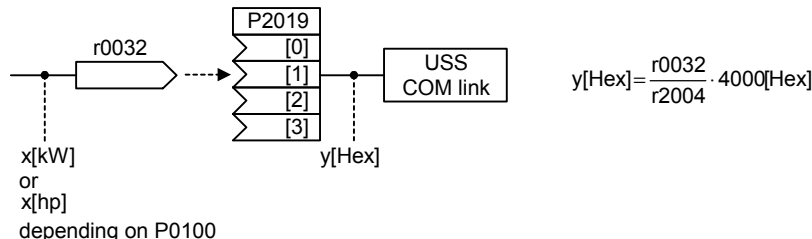

3.32 Communication parameters (USS, CB)

P2009[2]	USS denormalization	Min: 0	Level 3	
	CStat: CT	Datatype: U16		Def: 0
	P-Group: COMM	Active: first confirm		QuickComm.: No

Enables denormalization for USS.

Possible Settings:

0 Disabled
1 Enabled

Index:

P2009[0] : Serial interface COM link
P2009[1] : Serial interface BOP link

Note:

If denormalization is enabled, the main setpoint (word 2 in PZD) is not interpreted as 100 % = 4000H, but as "absolute" instead (e.g. 4000H = 16384 means 163.84 Hz) if this is a frequency. Denormalization (P2009 = 1) only works for frequencies and is intended for backwards compatibility with MM3.

P2010[2]	USS baudrate	Min: 4	Level 3	
	CStat: CUT	Datatype: U16		Def: 6
	P-Group: COMM	Active: first confirm		QuickComm.: No

Sets baud rate for USS communication.

Possible Settings:

4 2400 baud
5 4800 baud
6 9600 baud
7 19200 baud
8 38400 baud
9 57600 baud
10 76800 baud
11 93750 baud
12 115200 baud

Index:

P2010[0] : Serial interface COM link
P2010[1] : Serial interface BOP link

P2011[2]	USS address	Min: 0	Level 3	
	CStat: CUT	Datatype: U16		Def: 0
	P-Group: COMM	Active: first confirm		QuickComm.: No

Sets unique address for inverter.

Index:

P2011[0] : Serial interface COM link
P2011[1] : Serial interface BOP link

Note:

You can connect up to a further 30 inverters via the serial link (i.e. 31 inverters in total) and control them with the USS serial bus protocol.

P2012[2]	USS PZD length	Datatype: U16	Unit: -	Min: 0	Level 3
	CStat: CUT	Active: first confirm	QuickComm.: No	Def: 2	
	P-Group: COMM			Max: 8	

Defines the number of 16-bit words in PZD part of USS telegram.

Index:

- P2012[0] : Serial interface COM link
- P2012[1] : Serial interface BOP link

Notice:

USS protocol consists of PZD and PKW which can be changed by the user via parameters P2012 and P2013 respectively.

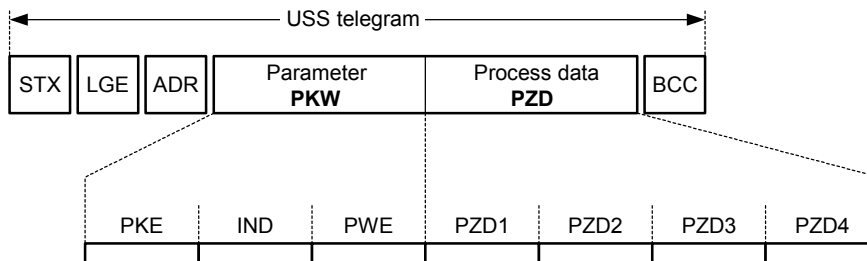

- | | | | |
|-----|-----------------------|-----|-----------------|
| STX | Start of text | PKE | Parameter ID |
| LGE | Length | IND | Sub-index |
| ADR | Address | PWE | Parameter value |
| PKW | Parameter ID value | | |
| PZD | Process data | | |
| BCC | Block check character | | |

PZD transmits a control word and setpoint or status word and actual values. The number of PZD-words in a USS-telegram are determined by parameter P2012, where the first two words (P2012 >= 2) are either:

- control word and main setpoint or
- status word and actual value.

Restrictions:

- If the serial interface controls the inverter (P0700 or P0719) then the 1st control word must be transferred in the 1st PZD-word.
- If the setpoint source is selected via P1000 or P0719, then the main setpoint must be transferred in the 2nd PZD-word.
- When P2012 is greater than or equal to 4 the additional control word (2nd control word) must be transferred in the 4th PZD-word, if the serial interface controls the inverter (P0700 or P0719).

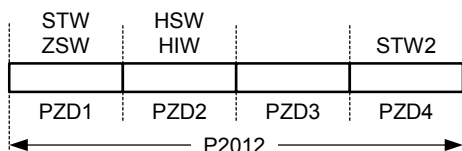

- | | | | |
|-----|--------------|-----|-------------------|
| STW | Control word | HSW | Main setpoint |
| ZSW | Status word | HIW | Main actual value |
| PZD | Process data | | |

P2013[2]	USS PKW length			Min: 0	Level 3
	CStat: CUT	Datatype: U16	Unit: -	Def: 127	
	P-Group: COMM	Active: first confirm	QuickComm.: No	Max: 127	

Defines the number of 16-bit words in PKW part of USS telegram.

The PKW area can be varied. Depending on the particular requirement, 3-word, 4-word or variable word lengths can be parameterized. The PKW part of the USS telegram is used to read and write individual parameter values.

Possible Settings:

- 0 No words
- 3 3 words
- 4 4 words
- 127 Variable

Index:

- P2013[0] : Serial interface COM link
- P2013[1] : Serial interface BOP link

Example:

	Data type		
	U16 (16 Bit)	U32 (32 Bit)	Float (32 Bit)
P2013 = 3	X	Parameter access fault	Parameter access fault
P2013 = 4	X	X	X
P2013 = 127	X	X	X

Notice:

USS protocol consists of PZD and PKW which can be changed by the user via parameters P2012 and P2013 respectively. Parameter P2013 determines the number of PKW-words in a USS-telegram.

Setting P2013 to 3 or 4 determines the length of the PKW (3 = three words and 4 = four words). When P2013 set to 127 automatically adjusts the length of the PKW words are required.

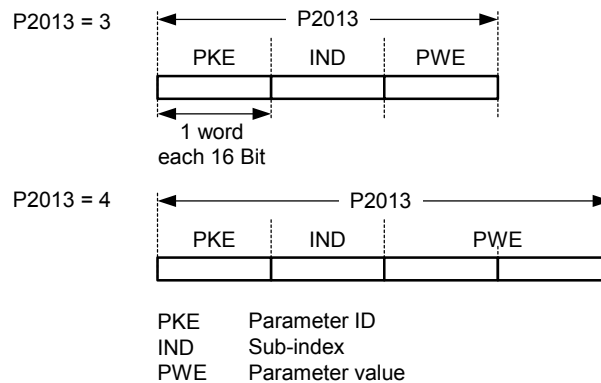

If a fixed PKW length is selected only one parameter value can be transferred. In the case of indexed parameter, you must use the variable PKW length if you wish to have the values of all indices transferred in a single telegram. In selecting the fixed PKW length, it is important to ensure the value in question can be transferred using this PKW length.

P2013 = 3, fixes PKW length, but does not allow access to many parameter values. A parameter fault is generated when an out-of-range value is used, the value will not be accepted but the inverter state will not be affected. Useful for applications where parameters are not changed, but MM3s are also used. Broadcast mode is not possible with this setting.

P2013 = 4, fixes PKW length. Allows access to all parameters, but indexed parameters can only be read one index at a time. Word order for single word values are different to setting 3 or 127, see example below.

P2013 = 127, most useful setting. PKW reply length varies depending on the amount of information needed. Can read fault information and all indices of a parameter with a single telegram with this setting.

Example:

Set P0700 to value 5 (0700 = 2BC (hex))

	P2013 = 3	P2013 = 4	P2013 = 127
Master → MM4	22BC 0000 0005	22BC 0000 0000 0005	22BC 0000 0005 0000
MM4 → Master	12BC 0000 0005	12BC 0000 0000 0005	12BC 0000 0005

P2014[2]	USS telegram off time	Min: 0	Level 3	
	CStat: CT	Datatype: U16		Unit: ms
	P-Group: COMM	Active: Immediately		QuickComm.: No
		Def: 0		
		Max: 65535		

Defines the telegram failure time for the serial interfaces with USS protocol.

The telegram failure time defines the time within which a valid telegram must have been received. If a valid telegram is not received within the specified time, the drive inverter outputs fault F0070.

Index:

- P2014[0] : Serial interface COM link
- P2014[1] : Serial interface BOP link

Notice:

By default (time set to 0), no fault is generated (i.e. watchdog disabled).

r2015[8]	CO: PZD from BOP link (USS)	Min: -	Level 3	
		Datatype: U16		Unit: -
	P-Group: COMM			Def: -
		Max: -		

Displays process data received via USS on BOP link (RS232 USS).

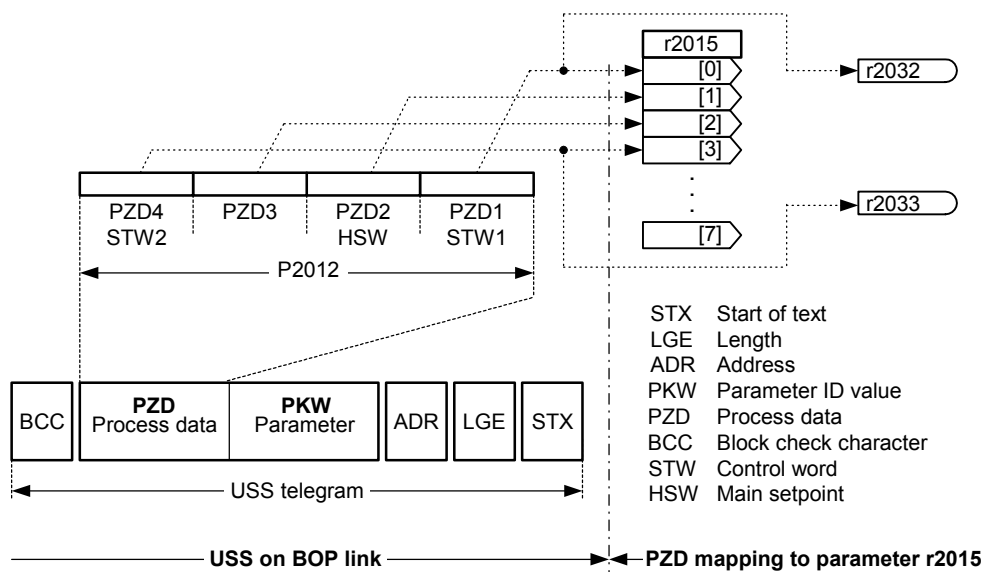

Index:

- r2015[0] : Received word 0
- r2015[1] : Received word 1
- r2015[2] : Received word 2
- r2015[3] : Received word 3
- r2015[4] : Received word 4
- r2015[5] : Received word 5
- r2015[6] : Received word 6
- r2015[7] : Received word 7

Note:

The control words can be viewed as bit parameters r2032 and r2033.

Restrictions:

- If the above serial interface controls the inverter (P0700 or P0719) then the 1st control word must be transferred in the 1st PZD-word.
- If the setpoint source is selected via P1000 or P0719, then the main setpoint must be transferred in the 2nd PZD-word.
- When P2012 is greater than or equal to 4 the additional control word (2nd control word) must be transferred in the 4th PZD-word, if the above serial interface controls the inverter (P0700 or P0719).

P2016[8]	CI: PZD to BOP link (USS)				Min: 0:0	Level 3
	CStat: CT	Datatype: U32	Unit: -	Def: 52:0		
	P-Group: COMM	Active: Immediately	QuickComm.: No	Max: 4000:0		

Selects signals (process data PZD) to be transmitted to serial interface via USS on BOP link

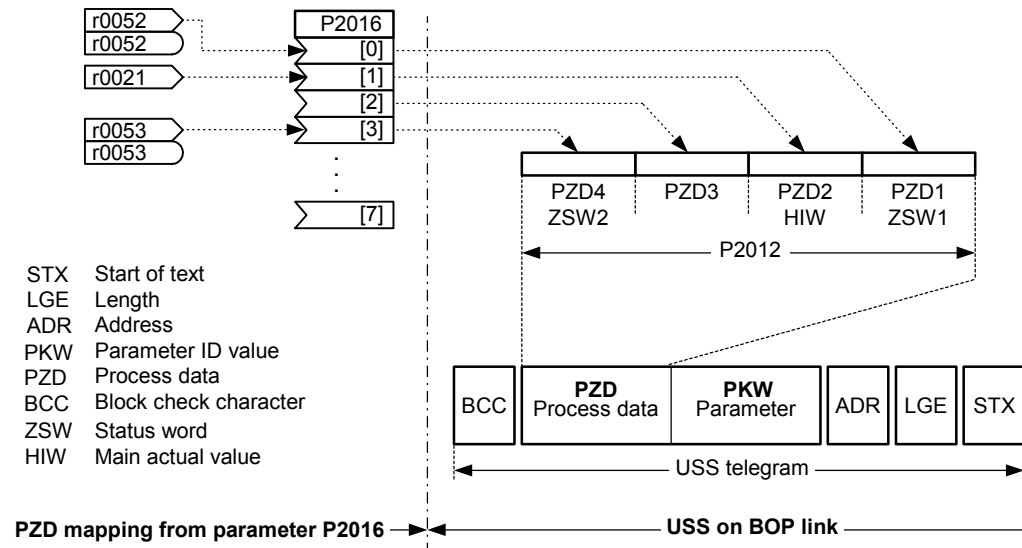

Index:

- P2016[0] : Transmitted word 0
- P2016[1] : Transmitted word 1
- P2016[2] : Transmitted word 2
- P2016[3] : Transmitted word 3
- P2016[4] : Transmitted word 4
- P2016[5] : Transmitted word 5
- P2016[6] : Transmitted word 6
- P2016[7] : Transmitted word 7

Example:

P2016[0] = 52.0 (default). In this case, the value of r0052[0] (CO/BO: Status word) is transmitted as 1st PZD to the BOP link.

Note:

If r0052 not indexed, display does not show an index (".0").

P2019[8]	CI: PZD to COM link (USS)			Min: 0:0	Level 3
	CStat: CT	Datatype: U32	Unit: -	Def: 52:0	
	P-Group: COMM	Active: Immediately	QuickComm.: No	Max: 4000:0	

Selects signals (process data PZD) to be transmitted to serial interface via USS on COM link

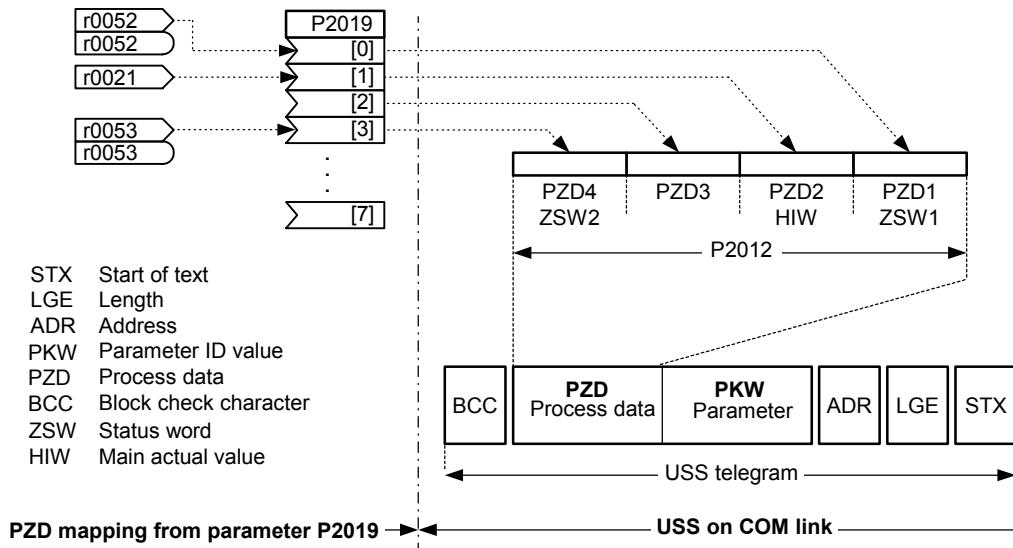

- Index:**
 P2019[0] : Transmitted word 0
 P2019[1] : Transmitted word 1
 P2019[2] : Transmitted word 2
 P2019[3] : Transmitted word 3
 P2019[4] : Transmitted word 4
 P2019[5] : Transmitted word 5
 P2019[6] : Transmitted word 6
 P2019[7] : Transmitted word 7

Details:
 See P2016 (PZD to BOP link)

r2024[2]	USS error-free telegrams			Min: -	Level 3
	Datatype: U16	Unit: -	Def: -	Max: -	
	P-Group: COMM				

Displays number of error-free USS telegrams received.

- Index:**
 r2024[0] : Serial interface COM link
 r2024[1] : Serial interface BOP link

r2025[2]	USS rejected telegrams			Min: -	Level 3
	Datatype: U16	Unit: -	Def: -	Max: -	
	P-Group: COMM				

Displays the number of rejected USS telegrams. The sum of all USS errors (r2026 - r2031) is displayed in parameter r2025.

The following monitoring mechanisms have been implemented

- when a telegram is received, then initially, the correct start of a telegram (start interval + STX) must be identified and then the length must be evaluated (LGE). If the length does not correspond to the selected value for a fixed telegram or it does not have a valid value for a variable telegram length, the telegram is rejected.
- the appropriate times are monitored before and while receiving telegrams.
- the block check character (BCC) is generated while the telegram is received and after the complete telegram has been read-in, this is compared with the received BCC. If these do not match, then the telegram is not evaluated.
- if a character frame error or a parity error has not occurred in any of the received characters, then the node number (ADR) of the received telegram can be evaluated.
- the telegram is rejected if the address byte (ADR) does not correspond to the node number (for slave) or the expected slave node number (for the master).

- Index:**
 r2025[0] : Serial interface COM link
 r2025[1] : Serial interface BOP link

r2026[2]	USS character frame error	Datatype: U16	Unit: -	Min: - Def: - Max: -	Level 3																																																																																																												
	P-Group: COMM																																																																																																																
	Displays number of USS character frame errors.																																																																																																																
Index:	r2026[0] : Serial interface COM link r2026[1] : Serial interface BOP link																																																																																																																
r2027[2]	USS overrun error	Datatype: U16	Unit: -	Min: - Def: - Max: -	Level 3																																																																																																												
	P-Group: COMM																																																																																																																
	Displays number of USS telegrams with overrun error.																																																																																																																
Index:	r2027[0] : Serial interface COM link r2027[1] : Serial interface BOP link																																																																																																																
r2028[2]	USS parity error	Datatype: U16	Unit: -	Min: - Def: - Max: -	Level 3																																																																																																												
	P-Group: COMM																																																																																																																
	Displays number of USS telegrams with parity error.																																																																																																																
Index:	r2028[0] : Serial interface COM link r2028[1] : Serial interface BOP link																																																																																																																
r2029[2]	USS start not identified	Datatype: U16	Unit: -	Min: - Def: - Max: -	Level 3																																																																																																												
	P-Group: COMM																																																																																																																
	Displays number of USS telegrams with unidentified start.																																																																																																																
Index:	r2029[0] : Serial interface COM link r2029[1] : Serial interface BOP link																																																																																																																
r2030[2]	USS BCC error	Datatype: U16	Unit: -	Min: - Def: - Max: -	Level 3																																																																																																												
	P-Group: COMM																																																																																																																
	Displays number of USS telegrams with BCC error.																																																																																																																
Index:	r2030[0] : Serial interface COM link r2030[1] : Serial interface BOP link																																																																																																																
r2031[2]	USS length error	Datatype: U16	Unit: -	Min: - Def: - Max: -	Level 3																																																																																																												
	P-Group: COMM																																																																																																																
	Displays number of USS telegrams with incorrect length.																																																																																																																
Index:	r2031[0] : Serial interface COM link r2031[1] : Serial interface BOP link																																																																																																																
r2032	BO: CtrlWrd1 from BOP link (USS)	Datatype: U16	Unit: -	Min: - Def: - Max: -	Level 3																																																																																																												
	P-Group: COMM																																																																																																																
	Displays control word 1 from BOP link (word 1 within USS).																																																																																																																
Bitfields:	<table border="0"> <tr> <td>Bit00</td> <td>ON/OFF1</td> <td>0</td> <td>NO</td> <td>1</td> <td>YES</td> </tr> <tr> <td>Bit01</td> <td>OFF2: Electrical stop</td> <td>0</td> <td>YES</td> <td>1</td> <td>NO</td> </tr> <tr> <td>Bit02</td> <td>OFF3: Fast stop</td> <td>0</td> <td>YES</td> <td>1</td> <td>NO</td> </tr> <tr> <td>Bit03</td> <td>Pulse enable</td> <td>0</td> <td>NO</td> <td>1</td> <td>YES</td> </tr> <tr> <td> </td> <td> </td> <td> </td> <td> </td> <td> </td> <td> </td> </tr> <tr> <td>Bit04</td> <td>RFG enable</td> <td>0</td> <td>NO</td> <td>1</td> <td>YES</td> </tr> <tr> <td>Bit05</td> <td>RFG start</td> <td>0</td> <td>NO</td> <td>1</td> <td>YES</td> </tr> <tr> <td>Bit06</td> <td>Setpoint enable</td> <td>0</td> <td>NO</td> <td>1</td> <td>YES</td> </tr> <tr> <td>Bit07</td> <td>Fault acknowledge</td> <td>0</td> <td>NO</td> <td>1</td> <td>YES</td> </tr> <tr> <td> </td> <td> </td> <td> </td> <td> </td> <td> </td> <td> </td> </tr> <tr> <td>Bit08</td> <td>JOG right</td> <td>0</td> <td>NO</td> <td>1</td> <td>YES</td> </tr> <tr> <td>Bit09</td> <td>JOG left</td> <td>0</td> <td>NO</td> <td>1</td> <td>YES</td> </tr> <tr> <td>Bit10</td> <td>Control from PLC</td> <td>0</td> <td>NO</td> <td>1</td> <td>YES</td> </tr> <tr> <td>Bit11</td> <td>Reverse (setpoint inversion)</td> <td>0</td> <td>NO</td> <td>1</td> <td>YES</td> </tr> <tr> <td> </td> <td> </td> <td> </td> <td> </td> <td> </td> <td> </td> </tr> <tr> <td>Bit13</td> <td>Motor potentiometer MOP up</td> <td>0</td> <td>NO</td> <td>1</td> <td>YES</td> </tr> <tr> <td>Bit14</td> <td>Motor potentiometer MOP down</td> <td>0</td> <td>NO</td> <td>1</td> <td>YES</td> </tr> <tr> <td>Bit15</td> <td>CDS Bit 0 (Local/Remote)</td> <td>0</td> <td>NO</td> <td>1</td> <td>YES</td> </tr> </table>					Bit00	ON/OFF1	0	NO	1	YES	Bit01	OFF2: Electrical stop	0	YES	1	NO	Bit02	OFF3: Fast stop	0	YES	1	NO	Bit03	Pulse enable	0	NO	1	YES							Bit04	RFG enable	0	NO	1	YES	Bit05	RFG start	0	NO	1	YES	Bit06	Setpoint enable	0	NO	1	YES	Bit07	Fault acknowledge	0	NO	1	YES							Bit08	JOG right	0	NO	1	YES	Bit09	JOG left	0	NO	1	YES	Bit10	Control from PLC	0	NO	1	YES	Bit11	Reverse (setpoint inversion)	0	NO	1	YES							Bit13	Motor potentiometer MOP up	0	NO	1	YES	Bit14	Motor potentiometer MOP down	0	NO	1	YES	Bit15	CDS Bit 0 (Local/Remote)	0	NO	1	YES
Bit00	ON/OFF1	0	NO	1	YES																																																																																																												
Bit01	OFF2: Electrical stop	0	YES	1	NO																																																																																																												
Bit02	OFF3: Fast stop	0	YES	1	NO																																																																																																												
Bit03	Pulse enable	0	NO	1	YES																																																																																																												
Bit04	RFG enable	0	NO	1	YES																																																																																																												
Bit05	RFG start	0	NO	1	YES																																																																																																												
Bit06	Setpoint enable	0	NO	1	YES																																																																																																												
Bit07	Fault acknowledge	0	NO	1	YES																																																																																																												
Bit08	JOG right	0	NO	1	YES																																																																																																												
Bit09	JOG left	0	NO	1	YES																																																																																																												
Bit10	Control from PLC	0	NO	1	YES																																																																																																												
Bit11	Reverse (setpoint inversion)	0	NO	1	YES																																																																																																												
Bit13	Motor potentiometer MOP up	0	NO	1	YES																																																																																																												
Bit14	Motor potentiometer MOP down	0	NO	1	YES																																																																																																												
Bit15	CDS Bit 0 (Local/Remote)	0	NO	1	YES																																																																																																												

r2033	BO: CtrlWrd2 from BOP link (USS)	Datatype: U16	Unit: -	Min: -	Level 3
	P-Group: COMM			Def: - Max: -	

Displays control word 2 from BOP link (i.e. word 4 within USS).

Bitfields:

Bit00	Fixed frequency Bit 0	0	NO	1	YES
Bit01	Fixed frequency Bit 1	0	NO	1	YES
Bit02	Fixed frequency Bit 2	0	NO	1	YES
Bit03	Fixed frequency Bit 3	0	NO	1	YES
Bit04	Drive data set (DDS) Bit 0	0	NO	1	YES
Bit05	Drive data set (DDS) Bit 1	0	NO	1	YES
Bit08	PID enabled	0	NO	1	YES
Bit09	DC brake enabled	0	NO	1	YES
Bit11	Droop enabled	0	NO	1	YES
Bit12	Torque control	0	NO	1	YES
Bit13	External fault 1	0	YES	1	NO
Bit15	Command data set (CDS) Bit 1	0	NO	1	YES

Dependency:

P0700 = 4 (USS on BOP link) and P0719 = 0 (Cmd / Setpoint = BICO parameter).

r2036	BO: CtrlWrd1 from COM link (USS)	Datatype: U16	Unit: -	Min: -	Level 3
	P-Group: COMM			Def: - Max: -	

Displays control word 1 from COM link (i.e. word 1 within USS).

Bitfields:

Bit00	ON/OFF1	0	NO	1	YES
Bit01	OFF2: Electrical stop	0	YES	1	NO
Bit02	OFF3: Fast stop	0	YES	1	NO
Bit03	Pulse enable	0	NO	1	YES
Bit04	RFG enable	0	NO	1	YES
Bit05	RFG start	0	NO	1	YES
Bit06	Setpoint enable	0	NO	1	YES
Bit07	Fault acknowledge	0	NO	1	YES
Bit08	JOG right	0	NO	1	YES
Bit09	JOG left	0	NO	1	YES
Bit10	Control from PLC	0	NO	1	YES
Bit11	Reverse (setpoint inversion)	0	NO	1	YES
Bit13	Motor potentiometer MOP up	0	NO	1	YES
Bit14	Motor potentiometer MOP down	0	NO	1	YES
Bit15	CDS Bit 0 (Local/Remote)	0	NO	1	YES

Details:

See r2033 (control word 2 from BOP link).

r2037	BO: CtrlWrd2 from COM link (USS)	Datatype: U16	Unit: -	Min: -	Level 3
	P-Group: COMM			Def: - Max: -	

Displays control word 2 from COM link (i.e. word 4 within USS).

Bitfields:

Bit00	Fixed frequency Bit 0	0	NO	1	YES
Bit01	Fixed frequency Bit 1	0	NO	1	YES
Bit02	Fixed frequency Bit 2	0	NO	1	YES
Bit03	Fixed frequency Bit 3	0	NO	1	YES
Bit04	Drive data set (DDS) Bit 0	0	NO	1	YES
Bit05	Drive data set (DDS) Bit 1	0	NO	1	YES
Bit08	PID enabled	0	NO	1	YES
Bit09	DC brake enabled	0	NO	1	YES
Bit11	Droop enabled	0	NO	1	YES
Bit12	Torque control	0	NO	1	YES
Bit13	External fault 1	0	YES	1	NO
Bit15	Command data set (CDS) Bit 1	0	NO	1	YES

Details:

See r2033 (control word 2 from BOP link).

P2040	CB telegram off time	Min: 0	Level 3	
	CStat: CT	Datatype: U16		Unit: ms
	P-Group: COMM	Active: Immediately		QuickComm.: No

Defines time after which a fault will be generated (F0070) if no telegram is received via the link.

Dependency:

Setting 0 = watchdog disabled

P2041[5]	CB parameter	Min: 0	Level 3	
	CStat: CT	Datatype: U16		Unit: -
	P-Group: COMM	Active: first confirm		QuickComm.: No

Configures a communication board (CB).

Index:

- P2041[0] : CB parameter 0
- P2041[1] : CB parameter 1
- P2041[2] : CB parameter 2
- P2041[3] : CB parameter 3
- P2041[4] : CB parameter 4

Details:

See relevant communication board manual for protocol definition and appropriate settings.

r2050[8]	CO: PZD from CB	Min: -	Level 3	
		Datatype: U16		Unit: -
	P-Group: COMM			Def: - Max: -

Displays PZD received from communication board (CB).

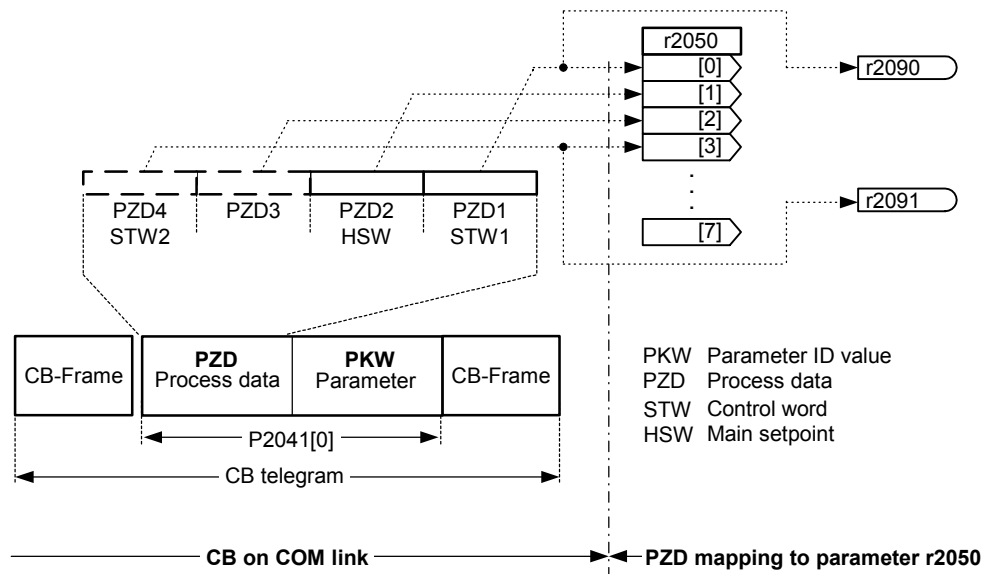

Index:

- r2050[0] : Received word 0
- r2050[1] : Received word 1
- r2050[2] : Received word 2
- r2050[3] : Received word 3
- r2050[4] : Received word 4
- r2050[5] : Received word 5
- r2050[6] : Received word 6
- r2050[7] : Received word 7

Note:

The control words can be viewed as bit parameters r2090 and r2091.

Restrictions:

- If the above serial interface controls the inverter (P0700 or P0719) then the 1st control word must be transferred in the 1st PZD-word.
- If the setpoint source is selected via P1000 or P0719, then the main setpoint must be transferred in the 2nd PZD-word,
- When P2012 is greater than or equal to 4 the additional control word (2nd control word) must be transferred in the 4th PZD-word, if the above serial interface controls the inverter (P0700 or P0719).

P2051[8]	CI: PZD to CB	Datatype: U32	Unit: -	Min: 0:0	Level 3
	CStat: CT	Active: Immediately	QuickComm.: No	Def: 52:0	
	P-Group: COMM			Max: 4000:0	

Selects signals (process data PZD) to be transmitted via CB on COM link

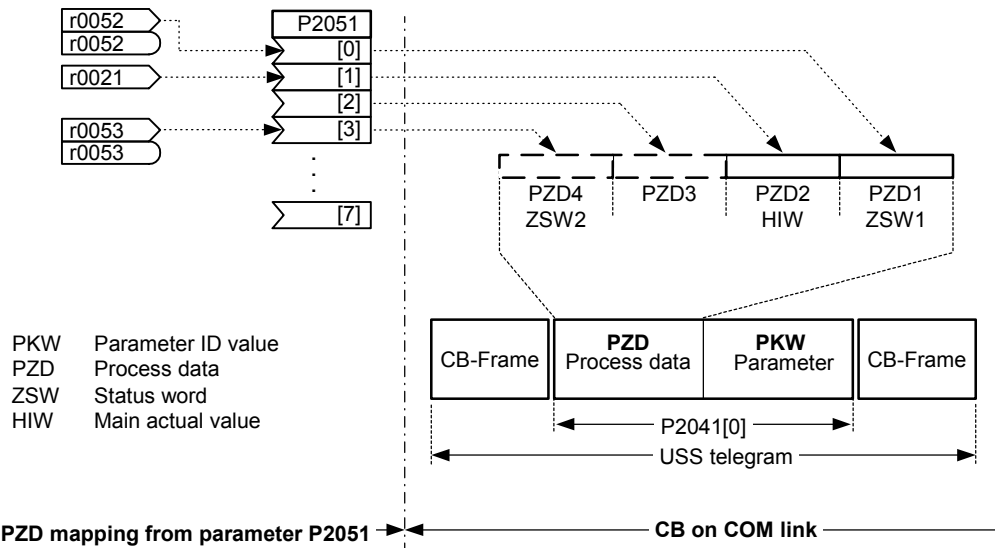

Index:

- P2051[0] : Transmitted word 0
- P2051[1] : Transmitted word 1
- P2051[2] : Transmitted word 2
- P2051[3] : Transmitted word 3
- P2051[4] : Transmitted word 4
- P2051[5] : Transmitted word 5
- P2051[6] : Transmitted word 6
- P2051[7] : Transmitted word 7

Common Settings:

- Status word 1 = 52 CO/BO: Act. status word 1 (see r0052)
- Actual value 1 = 21 inverter output frequency (see r0021)
- Other BICO settings are possible

r2053[5]	CB identification	Datatype: U16	Unit: -	Min: -	Level 3
	P-Group: COMM			Def: -	
				Max: -	

Displays identification data of the communication board (CB). The different CB types (r2053[0]) are given in the Enum declaration.

Possible Settings:

- 0 No CB option board
- 1 PROFIBUS DP
- 2 DeviceNet
- 256 not defined

Index:

- r2053[0] : CB type (PROFIBUS = 1)
- r2053[1] : Firmware version
- r2053[2] : Firmware version detail
- r2053[3] : Firmware date (year)
- r2053[4] : Firmware date (day/month)

r2054[7]	CB diagnosis	Datatype: U16	Unit: -	Min: -	Level 3
	P-Group: COMM			Def: -	
				Max: -	

Displays diagnostic information of communication board (CB).

Index:

- r2054[0] : CB diagnosis 0
- r2054[1] : CB diagnosis 1
- r2054[2] : CB diagnosis 2
- r2054[3] : CB diagnosis 3
- r2054[4] : CB diagnosis 4
- r2054[5] : CB diagnosis 5
- r2054[6] : CB diagnosis 6

Details:

See relevant communications board manual.

r2090	BO: Control word 1 from CB	Datatype: U16	Unit: -	Min: -	Level 3
	P-Group: COMM			Def: - Max: -	

Displays control word 1 received from communication board (CB).

Bitfields:

Bit00	ON/OFF1	0	NO	1	YES
Bit01	OFF2: Electrical stop	0	YES	1	NO
Bit02	OFF3: Fast stop	0	YES	1	NO
Bit03	Pulse enable	0	NO	1	YES
Bit04	RFG enable	0	NO	1	YES
Bit05	RFG start	0	NO	1	YES
Bit06	Setpoint enable	0	NO	1	YES
Bit07	Fault acknowledge	0	NO	1	YES
Bit08	JOG right	0	NO	1	YES
Bit09	JOG left	0	NO	1	YES
Bit10	Control from PLC	0	NO	1	YES
Bit11	Reverse (setpoint inversion)	0	NO	1	YES
Bit13	Motor potentiometer MOP up	0	NO	1	YES
Bit14	Motor potentiometer MOP down	0	NO	1	YES
Bit15	CDS Bit 0 (Local/Remote)	0	NO	1	YES

Details:

See relevant communication board manual for protocol definition and appropriate settings.

r2091	BO: Control word 2 from CB	Datatype: U16	Unit: -	Min: -	Level 3
	P-Group: COMM			Def: - Max: -	

Displays control word 2 received from communication board (CB).

Bitfields:

Bit00	Fixed frequency Bit 0	0	NO	1	YES
Bit01	Fixed frequency Bit 1	0	NO	1	YES
Bit02	Fixed frequency Bit 2	0	NO	1	YES
Bit03	Fixed frequency Bit 3	0	NO	1	YES
Bit04	Drive data set (DDS) Bit 0	0	NO	1	YES
Bit05	Drive data set (DDS) Bit 1	0	NO	1	YES
Bit08	PID enabled	0	NO	1	YES
Bit09	DC brake enabled	0	NO	1	YES
Bit11	Droop enabled	0	NO	1	YES
Bit12	Torque control	0	NO	1	YES
Bit13	External fault 1	0	YES	1	NO
Bit15	Command data set (CDS) Bit 1	0	NO	1	YES

Details:

See relevant communication board manual for protocol definition and appropriate settings.

3.33 Faults, Alarms, Monitoring

P2100[3]	Alarm number selection	Datatype: U16	Unit: -	Min: 0	Level 3
	CStat: CT P-Group: ALARMS	Active: first confirm	QuickComm.: No	Def: 0 Max: 65535	

Selects up to 3 faults or warnings for non-default reactions.

Index:

P2100[0] : Fault Number 1
P2100[1] : Fault Number 2
P2100[2] : Fault Number 3

Example:

If you want F0005 to perform an OFF3 instead of an OFF2, set P2100[0] = 5, then select the desired reaction in P2101[0] (in this case, set P2101[0] = 3).

Note:

All fault codes have a default reaction to OFF2. Some fault codes caused by hardware trips (e.g. overcurrent) cannot be changed from the default reactions.

P2101[3]	Stop reaction value	Min: 0	Level 3	
	CStat: CT	Datatype: U16		Unit: -
	P-Group: ALARMS	Active: first confirm		QuickComm.: No
		Def: 0		Max: 5

Sets drive stop reaction values for fault selected by P2100 (alarm number stop reaction).

This indexed parameter specifies the special reaction to the faults/warnings defined in P2100 indices 0 to 2.

Possible Settings:

- 0 No reaction, no display
- 1 OFF1 stop reaction
- 2 OFF2 stop reaction
- 3 OFF3 stop reaction
- 4 No reaction warning only
- 5 Goto fixed frequency 15

Index:

- P2101[0] : Stop reaction value 1
- P2101[1] : Stop reaction value 2
- P2101[2] : Stop reaction value 3

Note:

- Settings 0 - 3 only are available for fault codes.
- Settings 0 and 4 only are available for warnings.
- Index 0 (P2101) refers to fault/warning in index 0 (P2100).
- The value 5 can only be used for the following fault numbers: 70, 71, 72, 80.
- When the setpoint is lost, this function can be used to change over the drive to fixed frequency 15. This means, that when the setpoint is lost, the drive system can continue to run and plant-system downtimes can be avoided.

P2103[3]	BI: 1. Faults acknowledgement	Min: 0:0	Level 3	
	CStat: CT	Datatype: U32		Unit: -
	P-Group: COMMANDS	Active: first confirm		QuickComm.: No
		Def: 722:2		Max: 4000:0

Defines first source of fault acknowledgement, e.g. keypad/DIN, etc. (depending on setting).

Index:

- P2103[0] : 1st. Command data set (CDS)
- P2103[1] : 2nd. Command data set (CDS)
- P2103[2] : 3rd. Command data set (CDS)

Common Settings:

- 722.0 = Digital input 1 (requires P0701 to be set to 99, BICO)
- 722.1 = Digital input 2 (requires P0702 to be set to 99, BICO)
- 722.2 = Digital input 3 (requires P0703 to be set to 99, BICO)
- 722.3 = Digital input 4 (requires P0704 to be set to 99, BICO)
- 722.4 = Digital input 5 (requires P0705 to be set to 99, BICO)
- 722.5 = Digital input 6 (requires P0706 to be set to 99, BICO)
- 722.6 = Digital input 7 (via analog input 1, requires P0707 to be set to 99)
- 722.7 = Digital input 8 (via analog input 2, requires P0708 to be set to 99)

P2104[3]	BI: 2. Faults acknowledgement	Min: 0:0	Level 3	
	CStat: CT	Datatype: U32		Unit: -
	P-Group: COMMANDS	Active: first confirm		QuickComm.: No
		Def: 0:0		Max: 4000:0

Selects second source of fault acknowledgement.

Index:

- P2104[0] : 1st. Command data set (CDS)
- P2104[1] : 2nd. Command data set (CDS)
- P2104[2] : 3rd. Command data set (CDS)

Common Settings:

- 722.0 = Digital input 1 (requires P0701 to be set to 99, BICO)
- 722.1 = Digital input 2 (requires P0702 to be set to 99, BICO)
- 722.2 = Digital input 3 (requires P0703 to be set to 99, BICO)
- 722.3 = Digital input 4 (requires P0704 to be set to 99, BICO)
- 722.4 = Digital input 5 (requires P0705 to be set to 99, BICO)
- 722.5 = Digital input 6 (requires P0706 to be set to 99, BICO)
- 722.6 = Digital input 7 (via analog input 1, requires P0707 to be set to 99)
- 722.7 = Digital input 8 (via analog input 2, requires P0708 to be set to 99)

P2106[3]	BI: External fault			Min: 0:0	Level 3
	CStat: CT	Datatype: U32	Unit: -	Def: 1:0	
	P-Group: COMMANDS	Active: first confirm	QuickComm.: No	Max: 4000:0	

Selects source of external faults.

Index:

- P2106[0] : 1st. Command data set (CDS)
- P2106[1] : 2nd. Command data set (CDS)
- P2106[2] : 3rd. Command data set (CDS)

Common Settings:

- 722.0 = Digital input 1 (requires P0701 to be set to 99, BICO)
- 722.1 = Digital input 2 (requires P0702 to be set to 99, BICO)
- 722.2 = Digital input 3 (requires P0703 to be set to 99, BICO)
- 722.3 = Digital input 4 (requires P0704 to be set to 99, BICO)
- 722.4 = Digital input 5 (requires P0705 to be set to 99, BICO)
- 722.5 = Digital input 6 (requires P0706 to be set to 99, BICO)
- 722.6 = Digital input 7 (via analog input 1, requires P0707 to be set to 99)
- 722.7 = Digital input 8 (via analog input 2, requires P0708 to be set to 99)

r2110[4]	Warning number			Min: -	Level 3
		Datatype: U16	Unit: -	Def: -	
	P-Group: ALARMS			Max: -	

Displays warning information.

A maximum of 2 active warnings (indices 0 and 1) and 2 historical warnings (indices 2 and 3) may be viewed.

Index:

- r2110[0] : Recent Warnings --, warning 1
- r2110[1] : Recent Warnings --, warning 2
- r2110[2] : Recent Warnings -1, warning 3
- r2110[3] : Recent Warnings -1, warning 4

Note:

- Indices 0 and 1 are not stored.
- The keypad will flash while a warning is active. The LEDs indicate the warning status in this case.

P2111	Total number of warnings			Min: 0	Level 3
	CStat: CT	Datatype: U16	Unit: -	Def: 0	
	P-Group: ALARMS	Active: first confirm	QuickComm.: No	Max: 4	

Displays number of warning (up to 4) since last reset. Set to 0 to reset the warning history.

r2114[2]	Run time counter			Min: -	Level 3
		Datatype: U16	Unit: -	Def: -	
	P-Group: ALARMS			Max: -	

Displays run time counter.

It is the total time the drive has been powered up. When power goes value is saved, then restored on powerup. The run time counter r2114 will be calculate as followed:

- Multiply the value in r2114[0], by 65536 and then add it to the value in r2114[1].
- The resultant answer will be in seconds.

Total powerup time= 65536*r2114[0]+r2114[1] Secs.

When AOP is not connected, the time in this parameter is used by r0948 to indicate when a fault has occurred.

Index:

- r2114[0] : System Time, Seconds, Upper Word
- r2114[1] : System Time, Seconds, Lower Word

Example:

If r2114[0] = 1 & r2114[1] = 20864
 We get 1 * 65536 + 20864 = 86400 seconds which equals 1 day.

P2115[3]	AOP real time clock				Min: 0	Level 3
	CStat: CT	Datatype: U16	Unit: -	Def: 0		
	P-Group: ALARMS	Active: Immediately	QuickComm.: No	Max: 65535		

Displays AOP real time.

All of the frequency inverters have an internal time generator function which is used to time-stamp and log erroneous conditions. Therefore there is no battery-buffered real-time clock (RTC). The frequency inverters can support a software-controlled RTC where the RTC must be set from the AOP or via an interface. When using the AOP, this synchronization is automatic. When a serial interface is used, a task must be sent from the higher-level control to write into the parameter. If the AOP is withdrawn during operation, or if the bus is interrupted, then the real-time clock runs further using the runtime counter. The real-time clock is reset to zero only after power off.

The time is stored in a word array parameter P2115. This parameter number is common to all inverters. Inverters not supporting this feature would respond with parameter not recognised - a Master will ignore this. The time will be set by USS Protocol standard word array parameter write telegrams.

Within the AOP, while it is acting as a USS Master, at each tick of the heartbeat, the list of available USS Slaves will be flagged with a time update request. As the Master runs around the list of USS slaves on its next USS update cycle, if there are no higher priority tasks to perform, and the slave still has its time update flag set, then an array parameter write telegram will be issued, containing the current time. The request for that slave is cancelled if the slave responds correctly. The AOP will not need to read the time from the slave.

Time is maintained in a word array parameter and encoded as follows - the same format will be used in fault report logs.

Index	High Byte (MSB)	Low Byte (LSB)
0	Seconds (0 - 59)	Minutes (0 - 59)
1	Hours (0 - 23)	Days (1 - 31)
2	Month (1 - 12)	Years (00 - 250)

Time is measured from Jan 1st 2000. Values are in binary form.

Index:

- P2115[0] : Real Time, Seconds+Minutes
- P2115[1] : Real Time, Hours+Days
- P2115[2] : Real Time, Month+Year

Example:

- P2115[0] = 13625
- P2115[1] = 2579
- P2115[2] = 516

The conversion into binary quantities (U16) results in the following bit pattern:

Seconds + minutes:

- High byte (MSB) = 00110101 corresponding to the number 53, i.e. seconds 53
- Low byte (LSB) = 00111001 corresponding to the number 57, i.e. minutes 57

Hours + days:

- High byte (MSB) = 00001010 corresponding to the number 10, i.e. hours 10
- Low byte (LSB) = 00010011 corresponding to the number 19, i.e. days 19

Months + year:

- High byte (MSB) = 00000010 corresponding to the number 2, i.e. months 2
- Low byte (LSB) = 00000100 corresponding to the number 4, i.e. years 4

This means that the real time displayed in P2115 is 19.02.2004, 10:57:53.

P2150[3]	Hysteresis frequency f_hys	Min: 0.00	Level
	CStat: CUT	Datatype: Float	Def: 3.00
	P-Group: ALARMS	Active: Immediately	QuickComm.: No
		Unit: Hz	Max: 10.00

Defines hysteresis level applied for comparing frequency and speed to threshold as illustrated in the diagram below.

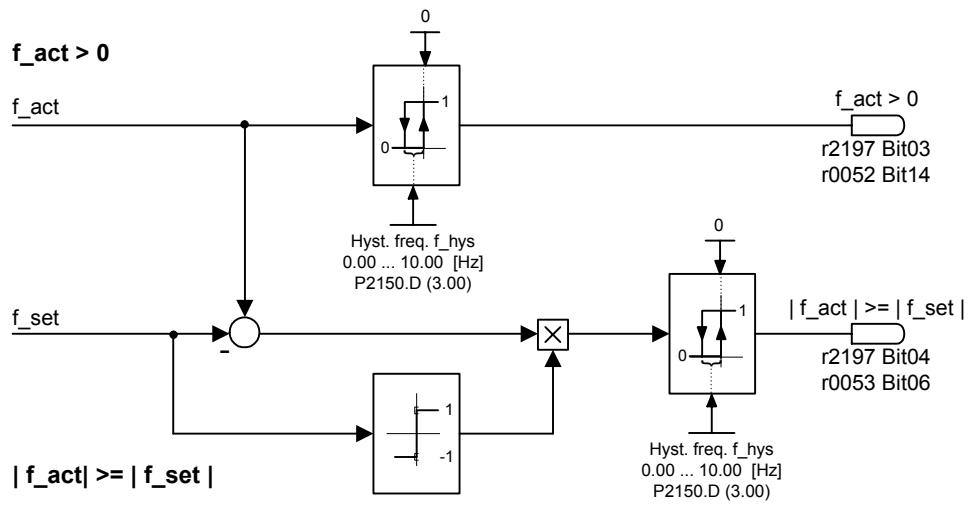

Index:
 P2150[0] : 1st. Drive data set (DDS)
 P2150[1] : 2nd. Drive data set (DDS)
 P2150[2] : 3rd. Drive data set (DDS)

P2153[3]	Time-constant frequency filter	Min: 0	Level
	CStat: CUT	Datatype: U16	Def: 5
	P-Group: ALARMS	Active: Immediately	QuickComm.: No
		Unit: ms	Max: 1000

Specifies time constant of first-order frequency filter. The filtered frequency is then compared to the thresholds.

Index:
 P2153[0] : 1st. Drive data set (DDS)
 P2153[1] : 2nd. Drive data set (DDS)
 P2153[2] : 3rd. Drive data set (DDS)

Details:
 See diagram in P2155, P2157 and P2159

P2155[3]	Threshold frequency f_1	Min: 0.00	Level
	CStat: CUT	Datatype: Float	Def: 30.00
	P-Group: ALARMS	Active: Immediately	QuickComm.: No
		Unit: Hz	Max: 650.00

Sets a threshold for comparing actual frequency or frequency to threshold values f_1. This threshold controls status bits 4 and 5 in status word 2 (r0053).

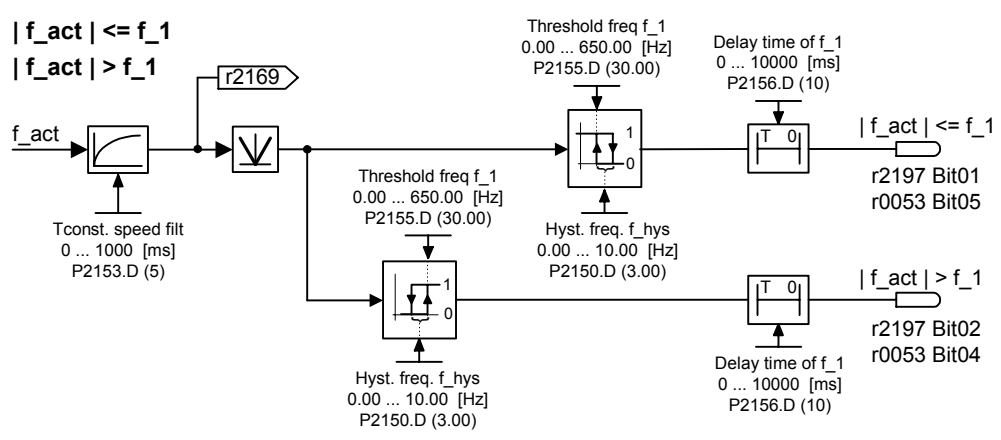

Index:
 P2155[0] : 1st. Drive data set (DDS)
 P2155[1] : 2nd. Drive data set (DDS)
 P2155[2] : 3rd. Drive data set (DDS)

P2156[3]	Delay time of threshold freq f_1	Min: 0	Level 3	
	CStat: CUT	Datatype: U16		Unit: ms
	P-Group: ALARMS	Active: Immediately		QuickComm.: No

Sets delay time prior to threshold frequency f_1 comparison (P2155).

Index:

- P2156[0] : 1st. Drive data set (DDS)
- P2156[1] : 2nd. Drive data set (DDS)
- P2156[2] : 3rd. Drive data set (DDS)

Details:

See diagram in P2155 (threshold frequency f_1)

P2157[3]	Threshold frequency f_2	Min: 0.00	Level 3	
	CStat: CUT	Datatype: Float		Unit: Hz
	P-Group: ALARMS	Active: Immediately		QuickComm.: No

Threshold_2 for comparing frequency or frequency to thresholds as illustrated in the diagram below.

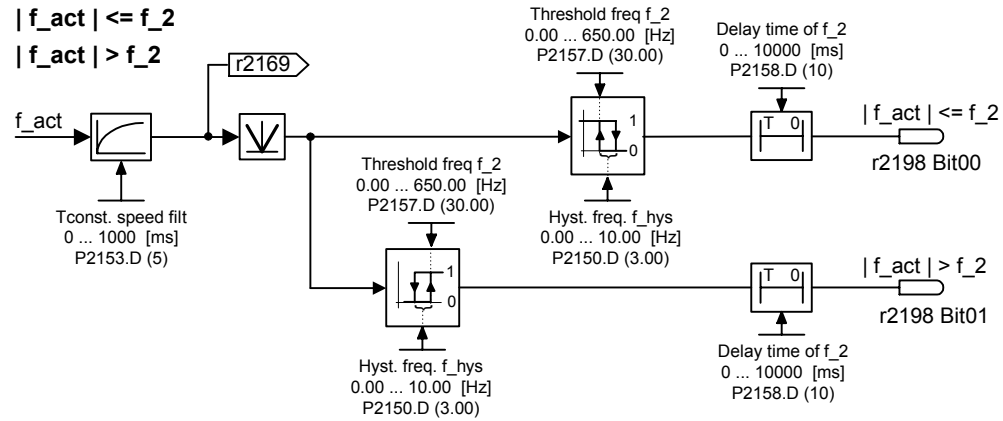

Index:

- P2157[0] : 1st. Drive data set (DDS)
- P2157[1] : 2nd. Drive data set (DDS)
- P2157[2] : 3rd. Drive data set (DDS)

P2158[3]	Delay time of threshold freq f_2	Min: 0	Level 3	
	CStat: CUT	Datatype: U16		Unit: ms
	P-Group: ALARMS	Active: Immediately		QuickComm.: No

When comparing frequency to threshold f_2 (P2157). This is the time delay before status bits are cleared.

Index:

- P2158[0] : 1st. Drive data set (DDS)
- P2158[1] : 2nd. Drive data set (DDS)
- P2158[2] : 3rd. Drive data set (DDS)

Details:

See diagram in P2157 (threshold frequency f_2)

P2159[3]	Threshold frequency f_3	Min: 0.00	Level 3	
	CStat: CUT	Datatype: Float		Unit: Hz
	P-Group: ALARMS	Active: Immediately		QuickComm.: No
		Def: 30.00		
		Max: 650.00		

Threshold_3 for comparing frequency to thresholds.

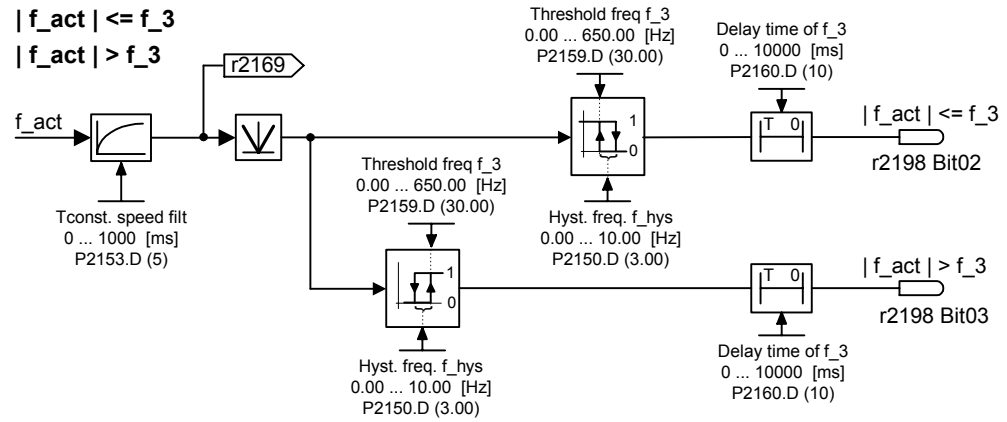

Index:

- P2159[0] : 1st. Drive data set (DDS)
- P2159[1] : 2nd. Drive data set (DDS)
- P2159[2] : 3rd. Drive data set (DDS)

P2160[3]	Delay time of threshold freq f_3	Min: 0	Level 3	
	CStat: CUT	Datatype: U16		Unit: ms
	P-Group: ALARMS	Active: Immediately		QuickComm.: No
		Def: 10		
		Max: 10000		

When comparing frequency to threshold f_3 (P2159). This is the time delay before status bits are set.

Index:

- P2160[0] : 1st. Drive data set (DDS)
- P2160[1] : 2nd. Drive data set (DDS)
- P2160[2] : 3rd. Drive data set (DDS)

Details:

See diagram in P2159 (threshold frequency f_3)

P2161[3]	Min. threshold for freq. setp.	Min: 0.00	Level 3	
	CStat: CUT	Datatype: Float		Unit: Hz
	P-Group: ALARMS	Active: Immediately		QuickComm.: No
		Def: 3.00		
		Max: 10.00		

Minimum threshold value for comparing frequency setpoint.

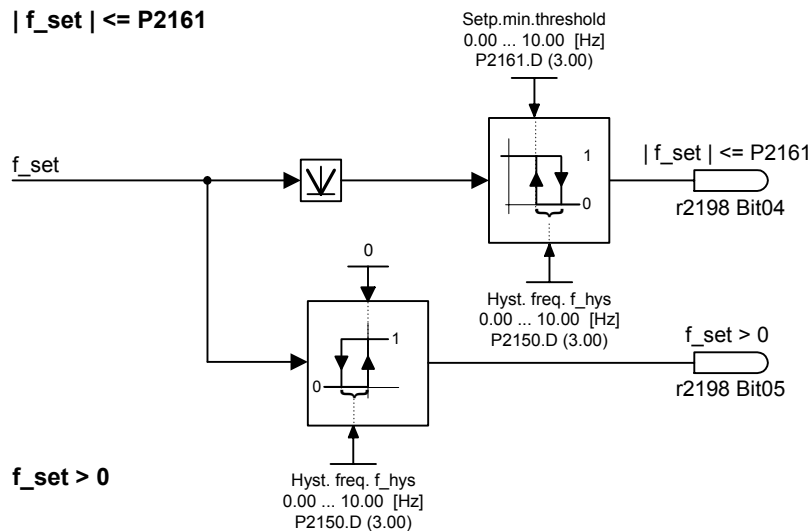

Index:

- P2161[0] : 1st. Drive data set (DDS)
- P2161[1] : 2nd. Drive data set (DDS)
- P2161[2] : 3rd. Drive data set (DDS)

P2162[3]	Hysteresis freq. for overfreq.	Min: 0.00	Level 3	
	CStat: CUT	Datatype: Float		Unit: Hz
	P-Group: ALARMS	Active: Immediately		QuickComm.: No
		Def: 20.00		
		Max: 650.00		

Hysteresis frequency for overfrequency-detection as illustrated in the diagram below.

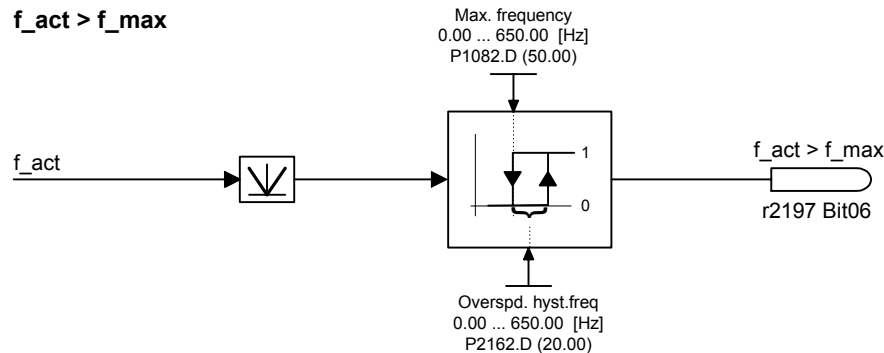

Index:

- P2162[0] : 1st. Drive data set (DDS)
- P2162[1] : 2nd. Drive data set (DDS)
- P2162[2] : 3rd. Drive data set (DDS)

P2163[3]	Entry freq. for perm. deviation	Min: 0.00	Level 3	
	CStat: CUT	Datatype: Float		Unit: Hz
	P-Group: ALARMS	Active: Immediately		QuickComm.: No
		Def: 3.00		
		Max: 20.00		

Threshold for detecting frequency deviation from setpoint as illustrated in the diagram P2164.

Index:

- P2163[0] : 1st. Drive data set (DDS)
- P2163[1] : 2nd. Drive data set (DDS)
- P2163[2] : 3rd. Drive data set (DDS)

P2164[3]	Hysteresis frequency deviation	Min: 0.00	Level 3	
	CStat: CUT	Datatype: Float		Unit: Hz
	P-Group: ALARMS	Active: Immediately		QuickComm.: No
		Def: 3.00		
		Max: 10.00		

Hysteresis frequency for detecting permitted deviation (from setpoint). This frequency controls bit 8 in status word 1 (r0052) and bit 6 in status word 2 (r0053).

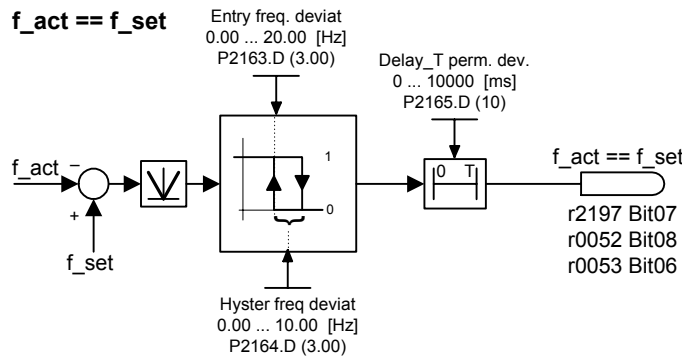

Index:

- P2164[0] : 1st. Drive data set (DDS)
- P2164[1] : 2nd. Drive data set (DDS)
- P2164[2] : 3rd. Drive data set (DDS)

P2165[3]	Delay time permitted deviation	Min: 0	Level 3	
	CStat: CUT	Datatype: U16		Unit: ms
	P-Group: ALARMS	Active: Immediately		QuickComm.: No
		Def: 10		
		Max: 10000		

Delay time for detecting permitted deviation of frequency from setpoint.

Index:

- P2165[0] : 1st. Drive data set (DDS)
- P2165[1] : 2nd. Drive data set (DDS)
- P2165[2] : 3rd. Drive data set (DDS)

Details:

See diagram in P2164.

P2166[3]	Delay time ramp up completed	Min: 0	Level 3	
	CStat: CUT	Datatype: U16		Unit: ms
	P-Group: ALARMS	Active: Immediately		QuickComm.: No

Delay time for signal that indicates completion of ramp-up.

Index:

- P2166[0] : 1st. Drive data set (DDS)
- P2166[1] : 2nd. Drive data set (DDS)
- P2166[2] : 3rd. Drive data set (DDS)

Details:

See diagram in P2174.

P2167[3]	Switch-off frequency f_{off}	Min: 0.00	Level 3	
	CStat: CUT	Datatype: Float		Unit: Hz
	P-Group: ALARMS	Active: Immediately		QuickComm.: No

Defines the threshold of the monitoring function $|f_{act}| > P2167 (f_{off})$.

P2167 influences following functions:

- If the actual frequency falls below this threshold and the time delay has expired, bit 1 in status word 2 (r0053) is reset.
- If a OFF1 or OFF3 was applied and bit 1 is reset the inverter will disable the pulse (OFF2).

Restriction:

- The monitoring function $|f_{act}| > P2167 (f_{off})$ is not updated and pulses are not disabled, if motor holding brake (MHB, P1215 = 1) is enabled.

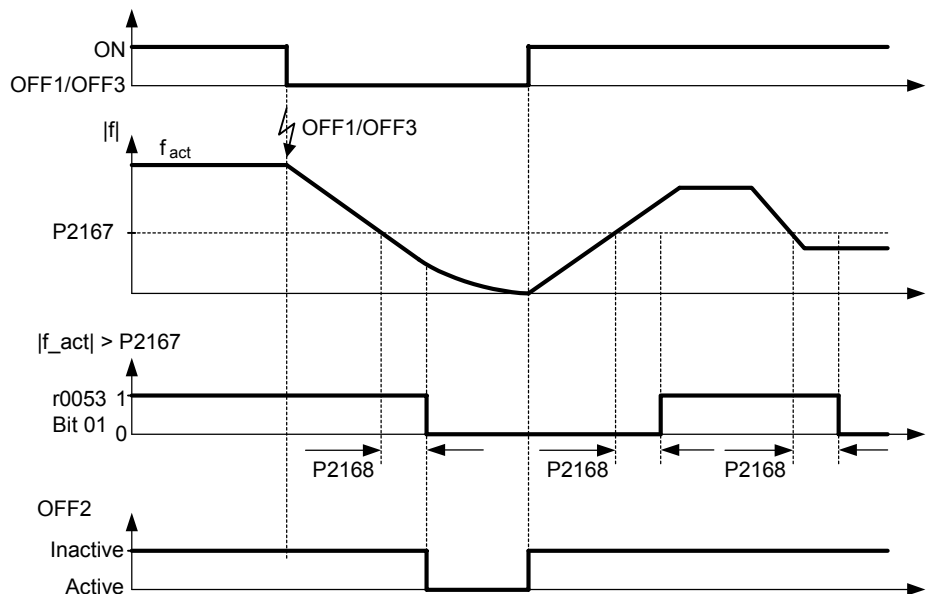

Index:

- P2167[0] : 1st. Drive data set (DDS)
- P2167[1] : 2nd. Drive data set (DDS)
- P2167[2] : 3rd. Drive data set (DDS)

P2168[3]	Delay time T_{off}	Min: 0	Level 3	
	CStat: CUT	Datatype: U16		Unit: ms
	P-Group: ALARMS	Active: Immediately		QuickComm.: No

Defines time for which the inverter may operate below switch-off frequency (P2167) before switch off occurs.

Index:

- P2168[0] : 1st. Drive data set (DDS)
- P2168[1] : 2nd. Drive data set (DDS)
- P2168[2] : 3rd. Drive data set (DDS)

Dependency:

Active if holding brake (P1215) not parameterized.

Details:

See diagram in P2167 (switch-off frequency)

r2169	CO: Act. filtered frequency	Datatype: Float	Unit: Hz	Min: -	Level 3
	P-Group: ALARMS			Def: - Max: -	

Filtered frequency for monitoring behind first-order lowpass filter.

- $|f_{act}| > f_{1}$ (see P2155)
- $|f_{act}| > f_{2}$ (see P2157)
- $|f_{act}| > f_{3}$ (see P2159)

P2170[3]	Threshold current I_thresh	Datatype: Float	Unit: %	Min: 0.0	Level 3
	CStat: CUT	Active: Immediately	QuickComm.: No	Def: 100.0 Max: 400.0	

Defines threshold current in [%] relative to P0305 (rated motor current) to be used in comparisons of I_act and I_Thresh as illustrated in the diagram below.

$$|I_{act}| > I_{thresh}$$

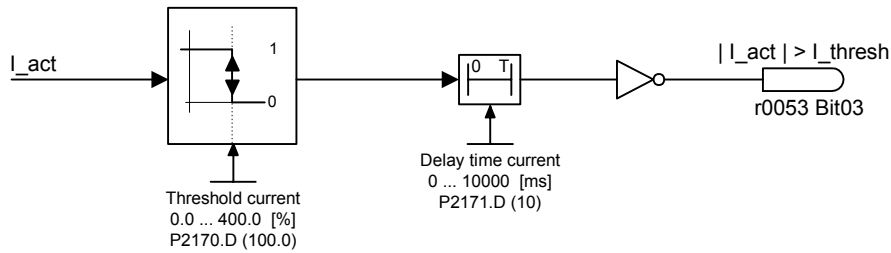

Index:

- P2170[0] : 1st. Drive data set (DDS)
- P2170[1] : 2nd. Drive data set (DDS)
- P2170[2] : 3rd. Drive data set (DDS)

Note:

This threshold controls bit 3 in status word 3 (r0053).

P2171[3]	Delay time current	Datatype: U16	Unit: ms	Min: 0	Level 3
	CStat: CUT	Active: Immediately	QuickComm.: No	Def: 10 Max: 10000	

Defines delay time prior to activation of current comparison.

Index:

- P2171[0] : 1st. Drive data set (DDS)
- P2171[1] : 2nd. Drive data set (DDS)
- P2171[2] : 3rd. Drive data set (DDS)

Details:

See diagram in P2170 (threshold current I_thresh)

P2172[3]	Threshold DC-link voltage	Min: 0	Level 3	
	CStat: CUT	Datatype: U16		Unit: V
	P-Group: ALARMS	Active: Immediately		QuickComm.: No
		Def: 800		
		Max: 2000		

Defines DC link voltage to be compared to actual voltage as illustrated in the diagram below.

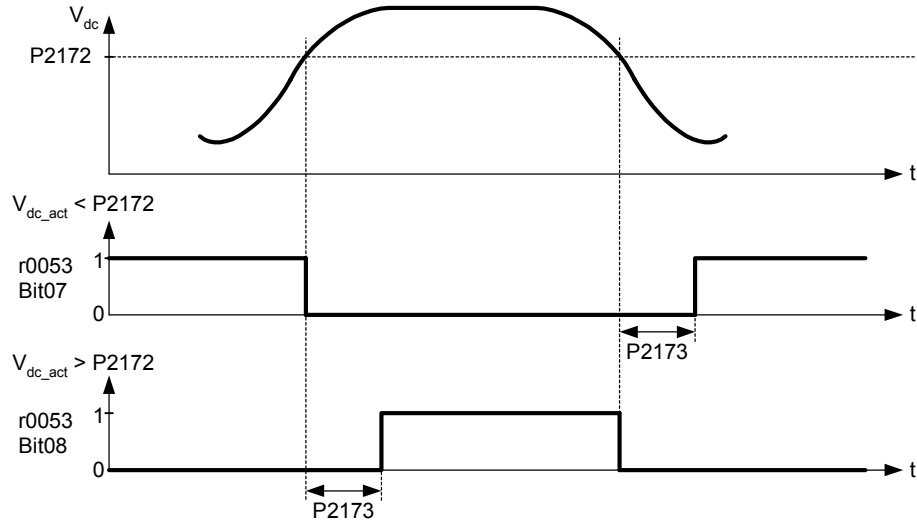

Index:

- P2172[0] : 1st. Drive data set (DDS)
- P2172[1] : 2nd. Drive data set (DDS)
- P2172[2] : 3rd. Drive data set (DDS)

Note:

This voltage controls bits 7 and 8 in status word 3 (r0053).

P2173[3]	Delay time DC-link voltage	Min: 0	Level 3	
	CStat: CUT	Datatype: U16		Unit: ms
	P-Group: ALARMS	Active: Immediately		QuickComm.: No
		Def: 10		
		Max: 10000		

Defines delay time prior to activation of threshold comparison.

Index:

- P2173[0] : 1st. Drive data set (DDS)
- P2173[1] : 2nd. Drive data set (DDS)
- P2173[2] : 3rd. Drive data set (DDS)

Details:

See diagram in P2172 (threshold DC-link voltage)

P2174[3]	Torque threshold M_thresh	Min: 0.00	Level
	CStat: CUT	Datatype: Float	Def: 5.13
	P-Group: ALARMS	Active: Immediately	QuickComm.: No
		Max: 99999.00	3

Defines torque threshold for comparing actual torque.

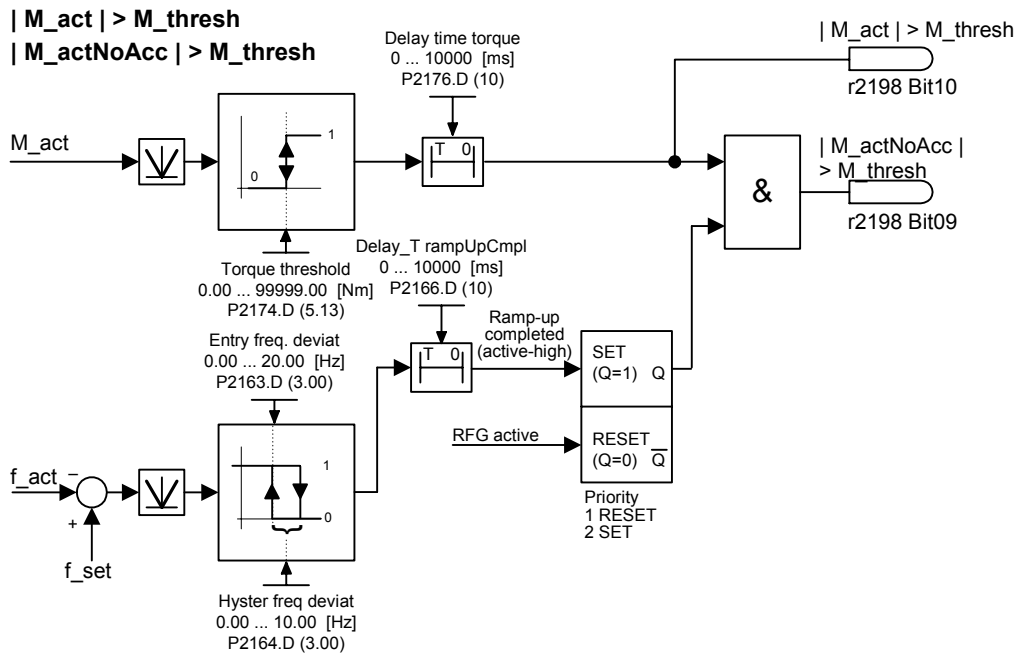

Index:

- P2174[0] : 1st. Drive data set (DDS)
- P2174[1] : 2nd. Drive data set (DDS)
- P2174[2] : 3rd. Drive data set (DDS)

P2176[3]	Delay time for torque threshold	Min: 0	Level
	CStat: CUT	Datatype: U16	Def: 10
	P-Group: ALARMS	Active: Immediately	QuickComm.: No
		Max: 10000	3

Delay time for comparing actual torque to threshold.

Index:

- P2176[0] : 1st. Drive data set (DDS)
- P2176[1] : 2nd. Drive data set (DDS)
- P2176[2] : 3rd. Drive data set (DDS)

P2177[3]	Delay time for motor is blocked	Min: 0	Level
	CStat: CUT	Datatype: U16	Def: 10
	P-Group: ALARMS	Active: Immediately	QuickComm.: No
		Max: 10000	3

Delay time for identification that motor is blocked.

Index:

- P2177[0] : 1st. Drive data set (DDS)
- P2177[1] : 2nd. Drive data set (DDS)
- P2177[2] : 3rd. Drive data set (DDS)

P2178[3]	Delay time for motor pulled out	Min: 0	Level
	CStat: CUT	Datatype: U16	Def: 10
	P-Group: ALARMS	Active: Immediately	QuickComm.: No
		Max: 10000	3

Delay time for identification that motor is pulled out.

Index:

- P2178[0] : 1st. Drive data set (DDS)
- P2178[1] : 2nd. Drive data set (DDS)
- P2178[2] : 3rd. Drive data set (DDS)

P2179	Current limit for no load ident.	Min: 0.0	Level 3	
	CStat: CUT	Datatype: Float		Unit: %
	P-Group: ALARMS	Active: Immediately		QuickComm.: No
		Def: 3.0		
		Max: 10.0		

Threshold current for A0922 (load missing) in [%] relative to P0305 (rated motor current) as illustrated in the diagram below.

Load missing

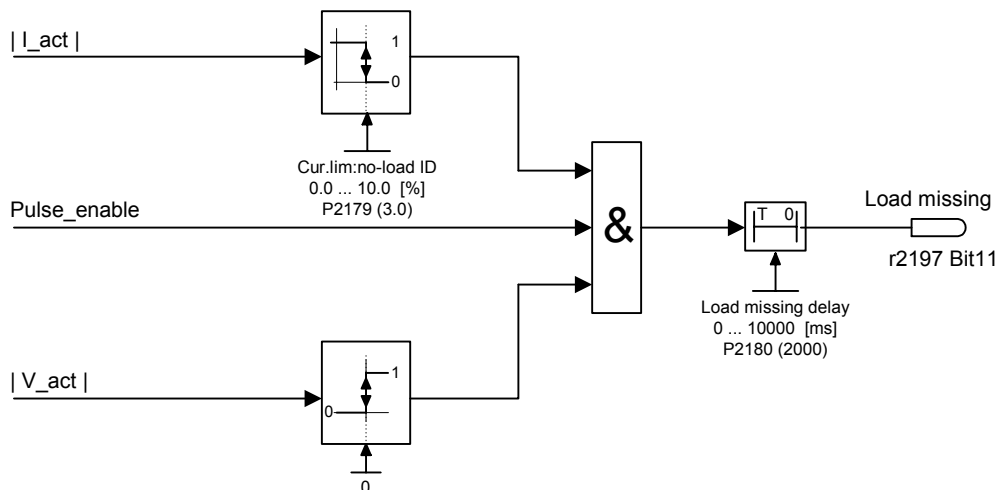

Note:

- It may be that the motor is not connected (load missing) or a phase could be missing.
- If a motor setpoint cannot be entered and the current limit (P2179) is not exceeded, Alarm A0922 (no load applied) is issued when delay time (P2180) expires.

P2180	Delay time for load missing	Min: 0	Level 3	
	CStat: CUT	Datatype: U16		Unit: ms
	P-Group: ALARMS	Active: Immediately		QuickComm.: No
		Def: 2000		
		Max: 10000		

Delay time to identify that the current is less than the threshold defined in P2179.

Details:

See diagram in P2179 (current limit for no load identification).

3.34 Load torque monitoring

P2181[3]	Belt failure detection mode	Min: 0	Level 3	
	CStat: CT	Datatype: U16		Unit: -
	P-Group: ALARMS	Active: first confirm		QuickComm.: No
		Def: 0		
		Max: 6		

Parameter P2181 activates or de-activates the load torque monitoring and defines the response to a load torque fault.

Using the load torque monitoring, it is possible to detect a mechanical failure or an overload condition of the mechanical transmission line, e.g. a broken drive belt or a stalled conveyor belt. In this case, the actual torque/frequency actual value is compared to a programmed envelope characteristic (refer to P2182 - P2190). If the actual torque/frequency actual value lies above or below the envelope curve, then after the delay time P2192 expires, as a function of P2181, alarm A0952 is output or the drive inverter is tripped with fault message F0452.

Possible Settings:

- 0 Belt failure detection disabled
- 1 Warning: Low torque / frequency
- 2 Warning: High torque / frequency
- 3 Warning: High / low torque / frequency
- 4 Trip: Low torque / frequency
- 5 Trip: High torque / frequency
- 6 Trip: High / low torque / frequency

Index:

- P2181[0] : 1st. Command data set (CDS)
- P2181[1] : 2nd. Command data set (CDS)
- P2181[2] : 3rd. Command data set (CDS)

P2182[3]	Belt threshold frequency 1				Min: 0.00	Level 3
	CStat: CUT	Datatype: Float	Unit: Hz	Def: 5.00		
	P-Group: ALARMS	Active: Immediately	QuickComm.: No	Max: 650.00		

Sets a frequency threshold 1 for comparing actual torque to torque the envelope for belt failure detection.

The frequency torque envelope is defined by 9 parameters - 3 are frequency parameters (P2182 - P2184), and the other 6 define the low and high torque limits (P2185 - P2190) for each frequency (see diagram below).

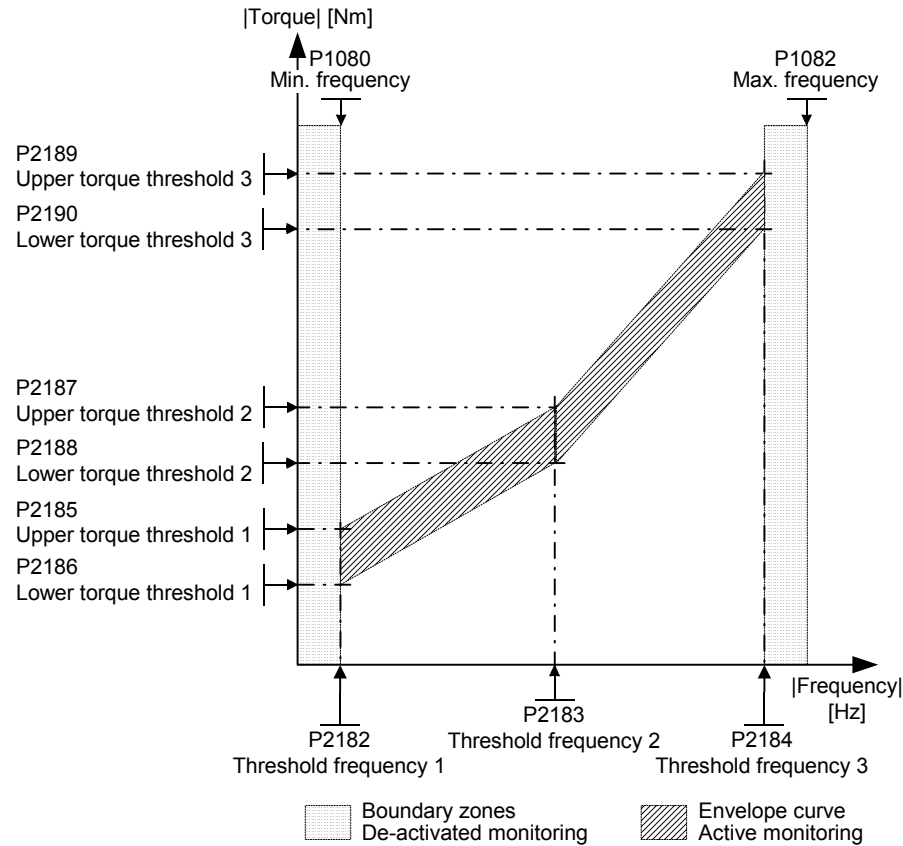

The allowed frequency/torque region is defined by the shaded area. When the torque falls outside the area shown, a trip or warning occurs (see parameter P2181).

Index:

- P2182[0] : 1st. Drive data set (DDS)
- P2182[1] : 2nd. Drive data set (DDS)
- P2182[2] : 3rd. Drive data set (DDS)

Note:

- The load torque monitoring function is not active below the frequency defined in P2182 and above the frequency defined in P2184.
- The current and torque limits of the drive inverter and motor still apply over the complete frequency range.
- The drive inverter output frequency is defined using Parameter P1080 and P1082. These limits should be carefully observed for the load torque monitoring frequencies.

P2183[3]	Belt threshold frequency 2				Min: 0.00	Level 3
	CStat: CUT	Datatype: Float	Unit: Hz	Def: 30.00		
	P-Group: ALARMS	Active: Immediately	QuickComm.: No	Max: 650.00		

Sets a threshold F2 for comparing actual torque to torque the envelope for belt failure detection.

Index:

- P2183[0] : 1st. Drive data set (DDS)
- P2183[1] : 2nd. Drive data set (DDS)
- P2183[2] : 3rd. Drive data set (DDS)

Details:

See P2182 (belt threshold frequency 1).

P2184[3]	Belt threshold frequency 3	Min: 0.00	Level 3
	CStat: CUT Datatype: Float Unit: Hz Def: 50.00 P-Group: ALARMS Active: Immediately QuickComm.: No Max: 650.00		
	Sets a threshold F3 for comparing actual torque to torque the envelope for belt failure detection.		
Index:	P2184[0] : 1st. Drive data set (DDS) P2184[1] : 2nd. Drive data set (DDS) P2184[2] : 3rd. Drive data set (DDS)		
Details:	See P2182 (belt threshold frequency 1).		
P2185[3]	Upper torque threshold 1	Min: 0.0	Level 3
	CStat: CUT Datatype: Float Unit: Nm Def: 99999.0 P-Group: ALARMS Active: Immediately QuickComm.: No Max: 99999.0		
	Upper limit threshold value 1 for comparing actual torque.		
Index:	P2185[0] : 1st. Drive data set (DDS) P2185[1] : 2nd. Drive data set (DDS) P2185[2] : 3rd. Drive data set (DDS)		
Details:	See P2182 (belt threshold frequency 1).		
P2186[3]	Lower torque threshold 1	Min: 0.0	Level 3
	CStat: CUT Datatype: Float Unit: Nm Def: 0.0 P-Group: ALARMS Active: Immediately QuickComm.: No Max: 99999.0		
	Lower limit threshold value 1 for comparing actual torque.		
Index:	P2186[0] : 1st. Drive data set (DDS) P2186[1] : 2nd. Drive data set (DDS) P2186[2] : 3rd. Drive data set (DDS)		
Details:	See P2182 (belt threshold frequency 1).		
P2187[3]	Upper torque threshold 2	Min: 0.0	Level 3
	CStat: CUT Datatype: Float Unit: Nm Def: 99999.0 P-Group: ALARMS Active: Immediately QuickComm.: No Max: 99999.0		
	Upper limit threshold value 2 for comparing actual torque.		
Index:	P2187[0] : 1st. Drive data set (DDS) P2187[1] : 2nd. Drive data set (DDS) P2187[2] : 3rd. Drive data set (DDS)		
Details:	See P2182 (belt threshold frequency 1).		
P2188[3]	Lower torque threshold 2	Min: 0.0	Level 3
	CStat: CUT Datatype: Float Unit: Nm Def: 0.0 P-Group: ALARMS Active: Immediately QuickComm.: No Max: 99999.0		
	Lower limit threshold value 2 for comparing actual torque.		
Index:	P2188[0] : 1st. Drive data set (DDS) P2188[1] : 2nd. Drive data set (DDS) P2188[2] : 3rd. Drive data set (DDS)		
Details:	See P2182 (belt threshold frequency 1).		
P2189[3]	Upper torque threshold 3	Min: 0.0	Level 3
	CStat: CUT Datatype: Float Unit: Nm Def: 99999.0 P-Group: ALARMS Active: Immediately QuickComm.: No Max: 99999.0		
	Upper limit threshold value 3 for comparing actual torque.		
Index:	P2189[0] : 1st. Drive data set (DDS) P2189[1] : 2nd. Drive data set (DDS) P2189[2] : 3rd. Drive data set (DDS)		
Details:	See P2182 (belt threshold frequency 1).		

P2190[3]	Lower torque threshold 3	Min: 0.0	Level 3	
	CStat: CUT	Datatype: Float		Unit: Nm
	P-Group: ALARMS	Active: Immediately		QuickComm.: No
		Def: 0.0		
		Max: 99999.0		

Lower limit threshold value 3 for comparing actual torque.

Index:

- P2190[0] : 1st. Drive data set (DDS)
- P2190[1] : 2nd. Drive data set (DDS)
- P2190[2] : 3rd. Drive data set (DDS)

Details:

See P2182 (belt threshold frequency 1).

P2192[3]	Time delay for belt failure	Min: 0	Level 3	
	CStat: CUT	Datatype: U16		Unit: s
	P-Group: ALARMS	Active: Immediately		QuickComm.: No
		Def: 10		
		Max: 65		

P2192 defines a delay before warning/trip becomes active. It is used to eliminate events caused by transient conditions. It is used for both methods of fault detection.

Index:

- P2192[0] : 1st. Drive data set (DDS)
- P2192[1] : 2nd. Drive data set (DDS)
- P2192[2] : 3rd. Drive data set (DDS)

r2197	CO/BO: Monitoring word 1	Min: -	Level 3	
		Datatype: U16		Unit: -
	P-Group: ALARMS			Def: -
		Max: -		

Monitoring word 1 which indicates the state of monitor functions. Each bit represents one monitor function.

Bitfields:

Bit00	f_act <= P1080 (f_min)	0	NO	1	YES
Bit01	f_act <= P2155 (f_1)	0	NO	1	YES
Bit02	f_act > P2155 (f_1)	0	NO	1	YES
Bit03	f_act > zero	0	NO	1	YES
Bit04	f_act >= setp. (f_set)	0	NO	1	YES
Bit05	f_act > P2167 (f_off)	0	NO	1	YES
Bit06	f_act >= P1082 (f_max)	0	NO	1	YES
Bit07	f_act == setp. (f_set)	0	NO	1	YES
Bit08	Act. current r0068 > P2170	0	NO	1	YES
Bit09	Act. unfilt. Vdc < P2172	0	NO	1	YES
Bit10	Act. unfilt. Vdc > P2172	0	NO	1	YES
Bit11	Load missing	0	NO	1	YES

r2198	CO/BO: Monitoring word 2	Min: -	Level 3	
		Datatype: U16		Unit: -
	P-Group: ALARMS			Def: -
		Max: -		

Monitoring word 2 which indicates the state of monitor functions. Each bit represents one monitor function.

Bitfields:

Bit00	f_act <= P2157 (f_2)	0	NO	1	YES
Bit01	f_act > P2157 (f_2)	0	NO	1	YES
Bit02	f_act <= P2159 (f_3)	0	NO	1	YES
Bit03	f_act > P2159 (f_3)	0	NO	1	YES
Bit04	f_set < P2161 (f_min_set)	0	NO	1	YES
Bit05	f_set > 0	0	NO	1	YES
Bit06	Motor blocked	0	NO	1	YES
Bit07	Motor pulled out	0	NO	1	YES
Bit08	I_act r0068 > P2170	0	NO	1	YES
Bit09	m_act > P2174 & setpoint reached	0	NO	1	YES
Bit10	m_act > P2174	0	NO	1	YES
Bit11	Belt failure warning	0	NO	1	YES
Bit12	Belt failure trip	0	NO	1	YES

3.35 Technology controller (PID controller)

P2200[3]	BI: Enable PID controller	Min: 0:0	Level 2	
	CStat: CUT	Datatype: U32		Unit: -
	P-Group: TECH	Active: first confirm		QuickComm.: No
		Def: 0:0		
		Max: 4000:0		

Allows user to enable/disable the PID controller.

P2200 settings :

- 0 : PID controller de-activated
- 1 : PID controller permanently activated
- BICO parameters : PID controller event-controlled, de-activated/activated

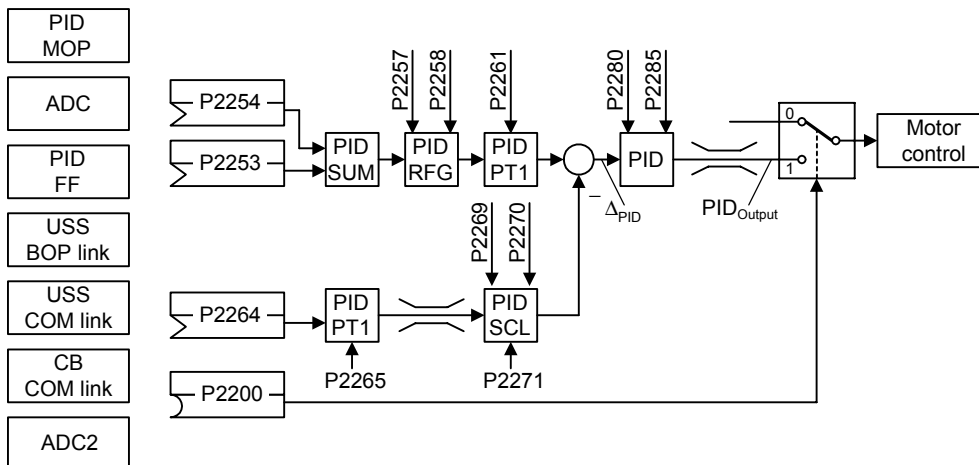

Index:

- P2200[0] : 1st. Command data set (CDS)
- P2200[1] : 2nd. Command data set (CDS)
- P2200[2] : 3rd. Command data set (CDS)

Common Settings:

Parameter	Parameter text	Setting	Meaning
P2200	BI: Enable PID controller	0	PID controller de-activated
		1.0	PID controller always active
		722.x	Digital input x
		BICO	BICO parameter
P2253	CI: PID setpoint	2224	Fixed PID setpoint (PID-FF)
		2250	PID-MOP
		755.0	Analog input 1
		2015.1	USS on BOP link
		2019.1	USS on COM link
		2050.1	CB on COM link
P2264	CI: PID feedback	755.0	Analog input 1
		755.1	Analog input 2

Dependency:

Setting 1 automatically disables normal ramp times set in P1120 and P1121 and the normal frequency setpoints.

Following an OFF1 or OFF3 command, however, the inverter frequency will ramp down to zero using the ramp time set in P1121 (P1135 for OFF3).

Note:

The PID setpoint source is selected using P2253. The PID setpoint and the PID feedback signal are interpreted as [%] values (not [Hz]). The output of the PID controller is displayed as [%] and then normalized into [Hz] through P2000 (reference frequency) when PID is enabled.

In level 3, the PID controller source enable can also come from the digital inputs in settings 722.0 to 722.5 for DIN1 to DIN6 or from any other BiCo source.

The minimum and maximum motor frequencies (P1080 and P1082) as well as the skip frequencies (P1091 to P1094) remain active on the inverter output. However, enabling skip frequencies with PID control can produce instabilities.

P2201[3]	Fixed PID setpoint 1	Datatype: Float	Unit: %	Min: -200.00	Level 3
	CStat: CUT	Active: Immediately	QuickComm.: No	Def: 0.00	
	P-Group: TECH			Max: 200.00	

Defines Fixed PID Setpoint 1

There are three options available for selection of the PID fixed setpoints:

1. Direct selection
 2. Direct selection + ON command
 3. Binary coded selection + ON command
1. Direct selection (P0701 - P0706 = 15):
 - In this mode of operation, 1 digital input selects one PID fixed setpoint.
 - If several inputs are active together, the selected setpoints are summed.
 - E.g.: PID-FF1 + PID-FF2 + PID-FF3 + PID-FF4 + PID-FF5 + PID-FF6.
 2. Direct selection + ON command (P0701 - P0706 = 16):
 - Description as for 1), except that this type of selection issues an ON command concurrent with any setpoint selection.
 - If several inputs are active together, the selected setpoints are summed.
 - E.g.: PID-FF1 + PID-FF2 + PID-FF3 + PID-FF4 + PID-FF5 + PID-FF6.
 3. Binary coded selection + ON command (P0701 - P0706 = 17):
 - Using this method to select the fixed PID setpoint (FF-PID) allows you to choose up to 16 different PID setpoints.
 - The setpoints are selected according to the following table:

Index:

- P2201[0] : 1st. Drive data set (DDS)
- P2201[1] : 2nd. Drive data set (DDS)
- P2201[2] : 3rd. Drive data set (DDS)

Example:

Binary coded selection

		DIN4	DIN3	DIN2	DIN1
0 %	PID - FF0	0	0	0	0
P1001	PID - FF1	0	0	0	1
P1002	PID - FF2	0	0	1	0
P1003	PID - FF3	0	0	1	1
P1004	PID - FF4	0	1	0	0
P1005	PID - FF5	0	1	0	1
P1006	PID - FF6	0	1	1	0
P1007	PID - FF7	0	1	1	1
P1008	PID - FF8	1	0	0	0
P1009	PID - FF9	1	0	0	1
P1010	PID - FF10	1	0	1	0
P1011	PID - FF11	1	0	1	1
P1012	PID - FF12	1	1	0	0
P1013	PID - FF13	1	1	0	1
P1014	PID - FF14	1	1	1	0
P1015	PID - FF15	1	1	1	1

Direct selection of PID-FF1 P2201 via DIN 1:

P0701 = 15
or
P0701 = 99, P2220 = 722.0, P2216 = 1

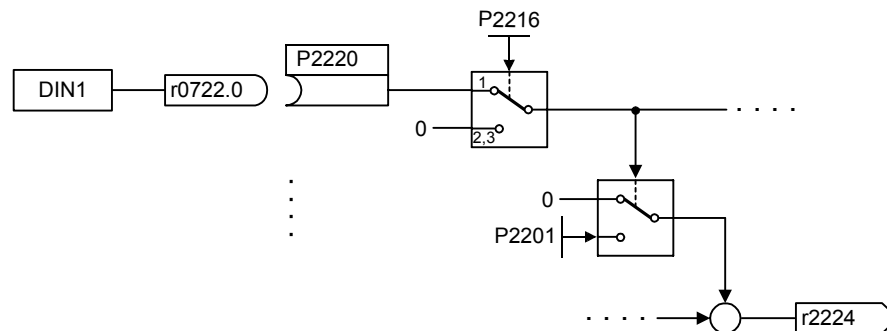

Dependency:

P2200 = 1 required in user access level 2 to enable setpoint source.

Note:

You may mix different types of frequencies; however, remember that they will be summed if selected together.
P2201 = 100 % corresponds to 4000 hex

P2202[3]	Fixed PID setpoint 2	Min: -200.00	Level
	CStat: CUT Datatype: Float Unit: % Def: 10.00 P-Group: TECH Active: Immediately QuickComm.: No Max: 200.00	3	
Defines Fixed PID Setpoint 2			
Index: P2202[0] : 1st. Drive data set (DDS) P2202[1] : 2nd. Drive data set (DDS) P2202[2] : 3rd. Drive data set (DDS)			
Details: See P2201 (Fixed PID Setpoint 1).			
P2203[3]	Fixed PID setpoint 3	Min: -200.00	Level
	CStat: CUT Datatype: Float Unit: % Def: 20.00 P-Group: TECH Active: Immediately QuickComm.: No Max: 200.00	3	
Defines Fixed PID Setpoint 3			
Index: P2203[0] : 1st. Drive data set (DDS) P2203[1] : 2nd. Drive data set (DDS) P2203[2] : 3rd. Drive data set (DDS)			
Details: See P2201 fixed PID setpoint 1 (FF-PID 1).			
P2204[3]	Fixed PID setpoint 4	Min: -200.00	Level
	CStat: CUT Datatype: Float Unit: % Def: 30.00 P-Group: TECH Active: Immediately QuickComm.: No Max: 200.00	3	
Defines Fixed PID Setpoint 4			
Index: P2204[0] : 1st. Drive data set (DDS) P2204[1] : 2nd. Drive data set (DDS) P2204[2] : 3rd. Drive data set (DDS)			
Details: See P2201 (Fixed PID Setpoint 1).			
P2205[3]	Fixed PID setpoint 5	Min: -200.00	Level
	CStat: CUT Datatype: Float Unit: % Def: 40.00 P-Group: TECH Active: Immediately QuickComm.: No Max: 200.00	3	
Defines Fixed PID Setpoint 5			
Index: P2205[0] : 1st. Drive data set (DDS) P2205[1] : 2nd. Drive data set (DDS) P2205[2] : 3rd. Drive data set (DDS)			
Details: See P2201 (Fixed PID Setpoint 1).			
P2206[3]	Fixed PID setpoint 6	Min: -200.00	Level
	CStat: CUT Datatype: Float Unit: % Def: 50.00 P-Group: TECH Active: Immediately QuickComm.: No Max: 200.00	3	
Defines Fixed PID Setpoint 6			
Index: P2206[0] : 1st. Drive data set (DDS) P2206[1] : 2nd. Drive data set (DDS) P2206[2] : 3rd. Drive data set (DDS)			
Details: See P2201 (Fixed PID Setpoint 1).			
P2207[3]	Fixed PID setpoint 7	Min: -200.00	Level
	CStat: CUT Datatype: Float Unit: % Def: 60.00 P-Group: TECH Active: Immediately QuickComm.: No Max: 200.00	3	
Defines Fixed PID Setpoint 7			
Index: P2207[0] : 1st. Drive data set (DDS) P2207[1] : 2nd. Drive data set (DDS) P2207[2] : 3rd. Drive data set (DDS)			
Details: See P2201 (Fixed PID Setpoint 1).			

P2208[3]	Fixed PID setpoint 8	Min: -200.00	Level
CStat: CUT	Datatype: Float	Unit: %	Def: 70.00
P-Group: TECH	Active: Immediately	QuickComm.: No	Max: 200.00
	Defines Fixed PID Setpoint 8		3
Index:	P2208[0] : 1st. Drive data set (DDS)		
	P2208[1] : 2nd. Drive data set (DDS)		
	P2208[2] : 3rd. Drive data set (DDS)		
Details:	See P2201 (Fixed PID Setpoint 1).		
P2209[3]	Fixed PID setpoint 9	Min: -200.00	Level
CStat: CUT	Datatype: Float	Unit: %	Def: 80.00
P-Group: TECH	Active: Immediately	QuickComm.: No	Max: 200.00
	Defines Fixed PID Setpoint 9		3
Index:	P2209[0] : 1st. Drive data set (DDS)		
	P2209[1] : 2nd. Drive data set (DDS)		
	P2209[2] : 3rd. Drive data set (DDS)		
Details:	See P2201 (Fixed PID Setpoint 1).		
P2210[3]	Fixed PID setpoint 10	Min: -200.00	Level
CStat: CUT	Datatype: Float	Unit: %	Def: 90.00
P-Group: TECH	Active: Immediately	QuickComm.: No	Max: 200.00
	Defines Fixed PID Setpoint 10		3
Index:	P2210[0] : 1st. Drive data set (DDS)		
	P2210[1] : 2nd. Drive data set (DDS)		
	P2210[2] : 3rd. Drive data set (DDS)		
Details:	See P2201 (Fixed PID Setpoint 1).		
P2211[3]	Fixed PID setpoint 11	Min: -200.00	Level
CStat: CUT	Datatype: Float	Unit: %	Def: 100.00
P-Group: TECH	Active: Immediately	QuickComm.: No	Max: 200.00
	Defines Fixed PID Setpoint 11		3
Index:	P2211[0] : 1st. Drive data set (DDS)		
	P2211[1] : 2nd. Drive data set (DDS)		
	P2211[2] : 3rd. Drive data set (DDS)		
Details:	See P2201 (Fixed PID Setpoint 1).		
P2212[3]	Fixed PID setpoint 12	Min: -200.00	Level
CStat: CUT	Datatype: Float	Unit: %	Def: 110.00
P-Group: TECH	Active: Immediately	QuickComm.: No	Max: 200.00
	Defines Fixed PID Setpoint 12		3
Index:	P2212[0] : 1st. Drive data set (DDS)		
	P2212[1] : 2nd. Drive data set (DDS)		
	P2212[2] : 3rd. Drive data set (DDS)		
Details:	See P2201 (Fixed PID Setpoint 1).		
P2213[3]	Fixed PID setpoint 13	Min: -200.00	Level
CStat: CUT	Datatype: Float	Unit: %	Def: 120.00
P-Group: TECH	Active: Immediately	QuickComm.: No	Max: 200.00
	Defines Fixed PID Setpoint 13		3
Index:	P2213[0] : 1st. Drive data set (DDS)		
	P2213[1] : 2nd. Drive data set (DDS)		
	P2213[2] : 3rd. Drive data set (DDS)		
Details:	See P2201 (Fixed PID Setpoint 1).		

P2214[3]	Fixed PID setpoint 14	Min: -200.00	Level 3	
	CStat: CUT	Datatype: Float		Unit: %
	P-Group: TECH	Active: Immediately		QuickComm.: No
		Def: 130.00		Max: 200.00

Defines Fixed PID Setpoint 14

Index:

P2214[0] : 1st. Drive data set (DDS)
 P2214[1] : 2nd. Drive data set (DDS)
 P2214[2] : 3rd. Drive data set (DDS)

Details:

See P2201 (Fixed PID Setpoint 1).

P2215[3]	Fixed PID setpoint 15	Min: -200.00	Level 3	
	CStat: CUT	Datatype: Float		Unit: %
	P-Group: TECH	Active: Immediately		QuickComm.: No
		Def: 130.00		Max: 200.00

Defines Fixed PID Setpoint 15

Index:

P2215[0] : 1st. Drive data set (DDS)
 P2215[1] : 2nd. Drive data set (DDS)
 P2215[2] : 3rd. Drive data set (DDS)

Details:

See P2201 (Fixed PID Setpoint 1).

P2216	Fixed PID setpoint mode - Bit 0	Min: 1	Level 3	
	CStat: CT	Datatype: U16		Unit: -
	P-Group: TECH	Active: first confirm		QuickComm.: No
		Def: 1		Max: 3

Fixed frequencies for PID setpoint can be selected in three different modes. Parameter P2216 defines the mode of selection Bit 0.

Possible Settings:

- 1 Direct selection
- 2 Direct selection + ON command
- 3 Binary coded selection + ON command

P2217	Fixed PID setpoint mode - Bit 1	Min: 1	Level 3	
	CStat: CT	Datatype: U16		Unit: -
	P-Group: TECH	Active: first confirm		QuickComm.: No
		Def: 1		Max: 3

BCD or direct selection Bit 1 for PID setpoint.

Possible Settings:

- 1 Direct selection
- 2 Direct selection + ON command
- 3 Binary coded selection + ON command

P2218	Fixed PID setpoint mode - Bit 2	Min: 1	Level 3	
	CStat: CT	Datatype: U16		Unit: -
	P-Group: TECH	Active: first confirm		QuickComm.: No
		Def: 1		Max: 3

BCD or direct selection Bit 2 for PID setpoint.

Possible Settings:

- 1 Direct selection
- 2 Direct selection + ON command
- 3 Binary coded selection + ON command

P2219	Fixed PID setpoint mode - Bit 3	Min: 1	Level 3	
	CStat: CT	Datatype: U16		Unit: -
	P-Group: TECH	Active: first confirm		QuickComm.: No
		Def: 1		Max: 3

BCD or direct selection Bit 3 for PID setpoint.

Possible Settings:

- 1 Direct selection
- 2 Direct selection + ON command
- 3 Binary coded selection + ON command

P2220[3]	BI: Fixed PID setp. select Bit 0				Min: 0:0	Level 3
	CStat: CT	Datatype: U32	Unit: -	Def: 0:0		
	P-Group: COMMANDS	Active: first confirm	QuickComm.: No	Max: 4000:0		

Defines command source of fixed PID setpoint selection Bit 0

Index:

P2220[0] : 1st. Command data set (CDS)
P2220[1] : 2nd. Command data set (CDS)
P2220[2] : 3rd. Command data set (CDS)

Common Settings:

722.0 = Digital input 1 (requires P0701 to be set to 99, BICO)
722.1 = Digital input 2 (requires P0702 to be set to 99, BICO)
722.2 = Digital input 3 (requires P0703 to be set to 99, BICO)
722.3 = Digital input 4 (requires P0704 to be set to 99, BICO)
722.4 = Digital input 5 (requires P0705 to be set to 99, BICO)
722.5 = Digital input 6 (requires P0706 to be set to 99, BICO)
722.6 = Digital input 7 (via analog input 1, requires P0707 to be set to 99)
722.7 = Digital input 8 (via analog input 2, requires P0708 to be set to 99)

P2221[3]	BI: Fixed PID setp. select Bit 1				Min: 0:0	Level 3
	CStat: CT	Datatype: U32	Unit: -	Def: 0:0		
	P-Group: COMMANDS	Active: first confirm	QuickComm.: No	Max: 4000:0		

Defines command source of fixed PID setpoint selection Bit 1.

Index:

P2221[0] : 1st. Command data set (CDS)
P2221[1] : 2nd. Command data set (CDS)
P2221[2] : 3rd. Command data set (CDS)

Common Settings:

722.0 = Digital input 1 (requires P0701 to be set to 99, BICO)
722.1 = Digital input 2 (requires P0702 to be set to 99, BICO)
722.2 = Digital input 3 (requires P0703 to be set to 99, BICO)
722.3 = Digital input 4 (requires P0704 to be set to 99, BICO)
722.4 = Digital input 5 (requires P0705 to be set to 99, BICO)
722.5 = Digital input 6 (requires P0706 to be set to 99, BICO)

P2222[3]	BI: Fixed PID setp. select Bit 2				Min: 0:0	Level 3
	CStat: CT	Datatype: U32	Unit: -	Def: 0:0		
	P-Group: COMMANDS	Active: first confirm	QuickComm.: No	Max: 4000:0		

Defines command source of fixed PID setpoint selection Bit 2

Index:

P2222[0] : 1st. Command data set (CDS)
P2222[1] : 2nd. Command data set (CDS)
P2222[2] : 3rd. Command data set (CDS)

Common Settings:

722.0 = Digital input 1 (requires P0701 to be set to 99, BICO)
722.1 = Digital input 2 (requires P0702 to be set to 99, BICO)
722.2 = Digital input 3 (requires P0703 to be set to 99, BICO)
722.3 = Digital input 4 (requires P0704 to be set to 99, BICO)
722.4 = Digital input 5 (requires P0705 to be set to 99, BICO)
722.5 = Digital input 6 (requires P0706 to be set to 99, BICO)

P2223[3]	BI: Fixed PID setp. select Bit 3				Min: 0:0	Level 3
	CStat: CT	Datatype: U32	Unit: -	Def: 722:3		
	P-Group: COMMANDS	Active: first confirm	QuickComm.: No	Max: 4000:0		

Defines command source of fixed PID setpoint selection Bit 3

Index:

P2223[0] : 1st. Command data set (CDS)
P2223[1] : 2nd. Command data set (CDS)
P2223[2] : 3rd. Command data set (CDS)

Common Settings:

722.0 = Digital input 1 (requires P0701 to be set to 99, BICO)
722.1 = Digital input 2 (requires P0702 to be set to 99, BICO)
722.2 = Digital input 3 (requires P0703 to be set to 99, BICO)
722.3 = Digital input 4 (requires P0704 to be set to 99, BICO)
722.4 = Digital input 5 (requires P0705 to be set to 99, BICO)
722.5 = Digital input 6 (requires P0706 to be set to 99, BICO)

r2224	CO: Act. fixed PID setpoint			Min: -	Level 3
		Datatype: Float	Unit: %	Def: -	
	P-Group: TECH			Max: -	

Displays total output of PID fixed setpoint selection.

Note:

r2224 = 100 % corresponds to 4000 hex

P2225	Fixed PID setpoint mode - Bit 4				Min: 1	Level 3
	CStat: CT	Datatype: U16	Unit: -	Def: 1		
	P-Group: TECH	Active: first confirm	QuickComm.: No	Max: 2		

Direct selection or direct selection + ON Bit 4 for PID setpoint.

Possible Settings:

- 1 Direct selection
- 2 Direct selection + ON command

P2226[3]	BI: Fixed PID setp. select Bit 4				Min: 0:0	Level 3
	CStat: CT	Datatype: U32	Unit: -	Def: 722:4		
	P-Group: COMMANDS	Active: first confirm	QuickComm.: No	Max: 4000:0		

Defines command source of fixed PID setpoint selection Bit 4

Index:

- P2226[0] : 1st. Command data set (CDS)
- P2226[1] : 2nd. Command data set (CDS)
- P2226[2] : 3rd. Command data set (CDS)

Common Settings:

- 722.0 = Digital input 1 (requires P0701 to be set to 99, BICO)
- 722.1 = Digital input 2 (requires P0702 to be set to 99, BICO)
- 722.2 = Digital input 3 (requires P0703 to be set to 99, BICO)
- 722.3 = Digital input 4 (requires P0704 to be set to 99, BICO)
- 722.4 = Digital input 5 (requires P0705 to be set to 99, BICO)
- 722.5 = Digital input 6 (requires P0706 to be set to 99, BICO)

P2227	Fixed PID setpoint mode - Bit 5				Min: 1	Level 3
	CStat: CT	Datatype: U16	Unit: -	Def: 1		
	P-Group: TECH	Active: first confirm	QuickComm.: No	Max: 2		

Direct selection / direct selection + ON Bit 5 for PID setpoint.

Possible Settings:

- 1 Direct selection
- 2 Direct selection + ON command

P2228[3]	BI: Fixed PID setp. select Bit 5				Min: 0:0	Level 3
	CStat: CT	Datatype: U32	Unit: -	Def: 722:5		
	P-Group: COMMANDS	Active: first confirm	QuickComm.: No	Max: 4000:0		

Defines command source of fixed PID setpoint selection Bit 5

Index:

- P2228[0] : 1st. Command data set (CDS)
- P2228[1] : 2nd. Command data set (CDS)
- P2228[2] : 3rd. Command data set (CDS)

Common Settings:

- 722.0 = Digital input 1 (requires P0701 to be set to 99, BICO)
- 722.1 = Digital input 2 (requires P0702 to be set to 99, BICO)
- 722.2 = Digital input 3 (requires P0703 to be set to 99, BICO)
- 722.3 = Digital input 4 (requires P0704 to be set to 99, BICO)
- 722.4 = Digital input 5 (requires P0705 to be set to 99, BICO)
- 722.5 = Digital input 6 (requires P0706 to be set to 99, BICO)

P2231[3]	Setpoint memory of PID-MOP				Min: 0	Level 3
	CStat: CUT	Datatype: U16	Unit: -	Def: 1		
	P-Group: TECH	Active: Immediately	QuickComm.: No	Max: 1		

Setpoint memory

Possible Settings:

- 0 PID-MOP setpoint will not be stored
- 1 PID-MOP setpoint will be stored (P2240 is updated)

Index:

- P2231[0] : 1st. Drive data set (DDS)
- P2231[1] : 2nd. Drive data set (DDS)
- P2231[2] : 3rd. Drive data set (DDS)

Dependency:

P2231 = 0:
If 0 selected, setpoint returns to value set in P2240 (setpoint of PID-MOP) after an OFF command.

P2231 = 1:
If 1 is selected, active setpoint is 'remembered' and P2240 updated with current value.

Details:

See P2240 (setpoint of PID-MOP)

P2232	Inhibit neg. PID-MOP setpoints				Min: 0	Level 3
	CStat: CT	Datatype: U16	Unit: -	Def: 1		
	P-Group: TECH	Active: first confirm	QuickComm.: No	Max: 1		

This parameter suppresses negative setpoints of the PID-MOP output r2250.

Possible Settings:

- 0 Neg. PID-MOP setpoint is allowed
- 1 Neg. PID-MOP setpoint inhibited

Note:

Setting 0 enables a change of motor direction using the motor potentiometer setpoint (increase/decrease frequency either by using digital inputs or motor potentiometer up/down buttons).

P2235[3]	BI: Enable PID-MOP (UP-cmd)				Min: 0:0	Level 3
	CStat: CT	Datatype: U32	Unit: -	Def: 19:13		
	P-Group: COMMANDS	Active: first confirm	QuickComm.: No	Max: 4000:0		

Defines source of UP command.

Index:

- P2235[0] : 1st. Command data set (CDS)
- P2235[1] : 2nd. Command data set (CDS)
- P2235[2] : 3rd. Command data set (CDS)

Common Settings:

- 722.0 = Digital input 1 (requires P0701 to be set to 99, BICO)
- 722.1 = Digital input 2 (requires P0702 to be set to 99, BICO)
- 722.2 = Digital input 3 (requires P0703 to be set to 99, BICO)
- 722.3 = Digital input 4 (requires P0704 to be set to 99, BICO)
- 722.4 = Digital input 5 (requires P0705 to be set to 99, BICO)
- 722.5 = Digital input 6 (requires P0706 to be set to 99, BICO)
- 19.D = Keypad UP button

Dependency:

To change setpoint:

1. Use UP / DOWN key on BOP or
2. Set P0702/P0703 = 13/14 (function of digital inputs 2 and 3)

P2236[3]	BI: Enable PID-MOP (DOWN-cmd)				Min: 0:0	Level 3
	CStat: CT	Datatype: U32	Unit: -	Def: 19:14		
	P-Group: COMMANDS	Active: first confirm	QuickComm.: No	Max: 4000:0		

Defines source of DOWN command.

Index:

- P2236[0] : 1st. Command data set (CDS)
- P2236[1] : 2nd. Command data set (CDS)
- P2236[2] : 3rd. Command data set (CDS)

Common Settings:

- 722.0 = Digital input 1 (requires P0701 to be set to 99, BICO)
- 722.1 = Digital input 2 (requires P0702 to be set to 99, BICO)
- 722.2 = Digital input 3 (requires P0703 to be set to 99, BICO)
- 722.3 = Digital input 4 (requires P0704 to be set to 99, BICO)
- 722.4 = Digital input 5 (requires P0705 to be set to 99, BICO)
- 722.5 = Digital input 6 (requires P0706 to be set to 99, BICO)
- 722.6 = Digital input 7 (via analog input 1, requires P0707 to be set to 99)
- 722.7 = Digital input 8 (via analog input 2, requires P0708 to be set to 99)
- 19.E = Keypad DOWN button

Dependency:

To change setpoint:

1. Use UP / DOWN key on BOP or
2. Set P0702/P0703 = 13/14 (function of digital inputs 2 and 3)

P2240[3]	Setpoint of PID-MOP				Min: -200.00	Level 3
	CStat: CUT	Datatype: Float	Unit: %	Def: 10.00		
	P-Group: TECH	Active: Immediately	QuickComm.: No	Max: 200.00		

Setpoint of the motor potentiometer.

Allows user to set a digital PID setpoint in [%].

Index:

- P2240[0] : 1st. Drive data set (DDS)
- P2240[1] : 2nd. Drive data set (DDS)
- P2240[2] : 3rd. Drive data set (DDS)

Note:

P2240 = 100 % corresponds to 4000 hex

r2250	CO: Output setpoint of PID-MOP	Min: -	Level 3
	Datatype: Float Unit: %	Def: - Max: -	
P-Group: TECH			

Displays output setpoint of motor potentiometer in [%].

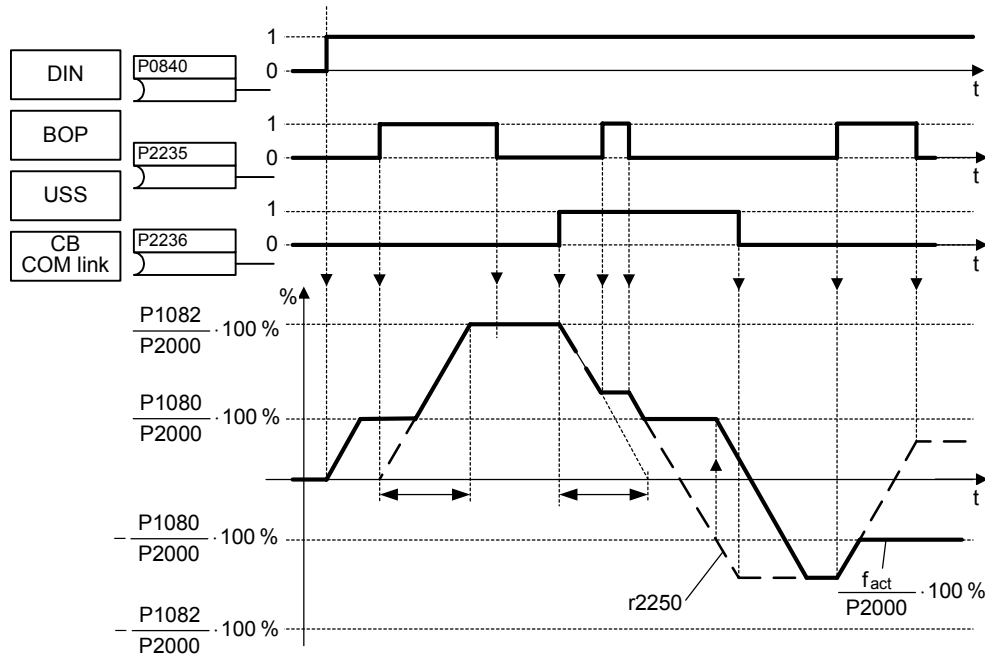

Note:
r2250 = 100 % corresponds to 4000 hex

P2253[3]	CI: PID setpoint	Min: 0:0	Level 2	
	CStat: CUT	Datatype: U32		Unit: -
	P-Group: TECH	Active: first confirm		QuickComm.: No
		Def: 2250:0		
		Max: 4000:0		

Defines setpoint source for PID setpoint input.

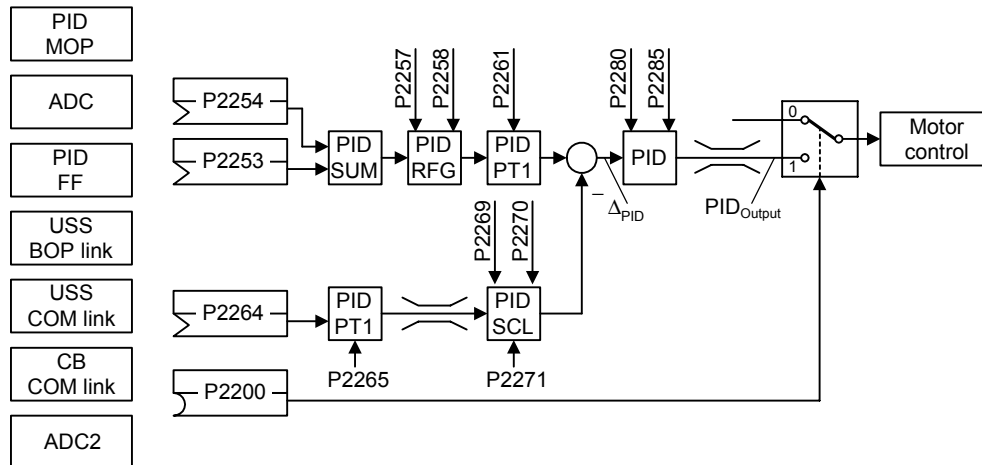

Index:

- P2253[0] : 1st. Command data set (CDS)
- P2253[1] : 2nd. Command data set (CDS)
- P2253[2] : 3rd. Command data set (CDS)

Common Settings:

Parameter	Parameter text	Setting	Meaning
P2200	BI: Enable PID controller	0	PID controller de-activated
		1.0	PID controller always active
		722.x	Digital input x
		BICO	BICO parameter
P2253	CI: PID setpoint	2224	Fixed PID setpoint (PID-FF)
		2250	PID-MOP
		755.0	Analog input 1
		2015.1	USS on BOP link
		2019.1	USS on COM link
P2264	CI: PID feedback	2050.1	CB on COM link
		755.0	Analog input 1
		755.1	Analog input 2

P2254[3]	CI: PID trim source	Min: 0:0	Level 3	
	CStat: CUT	Datatype: U32		Unit: -
	P-Group: TECH	Active: first confirm		QuickComm.: No
		Def: 0:0		
		Max: 4000:0		

Selects trim source for PID setpoint. This signal is multiplied by the trim gain and added to the PID setpoint.

Index:

- P2254[0] : 1st. Command data set (CDS)
- P2254[1] : 2nd. Command data set (CDS)
- P2254[2] : 3rd. Command data set (CDS)

Common Settings:

See parameter P2253

P2255	PID setpoint gain factor	Min: 0.00	Level 3	
	CStat: CUT	Datatype: Float		Unit: -
	P-Group: TECH	Active: Immediately		QuickComm.: No
		Def: 100.00		
		Max: 100.00		

Gain factor for PID setpoint. The PID setpoint input is multiplied by this gain factor to produce a suitable ratio between setpoint and trim.

P2256	PID trim gain factor	Min: 0.00	Level 3	
	CStat: CUT	Datatype: Float		Unit: -
	P-Group: TECH	Active: Immediately		QuickComm.: No
		Def: 100.00		
		Max: 100.00		

Gain factor for PID trim. This gain factor scales the trim signal, which is added to the main PID setpoint.

P2257	Ramp-up time for PID setpoint	Min: 0.00	Level 2	
	CStat: CUT	Datatype: Float		Unit: s
	P-Group: TECH	Active: Immediately		QuickComm.: No
		Def: 1.00		
		Max: 650.00		

Sets the ramp-up time for the PID setpoint.

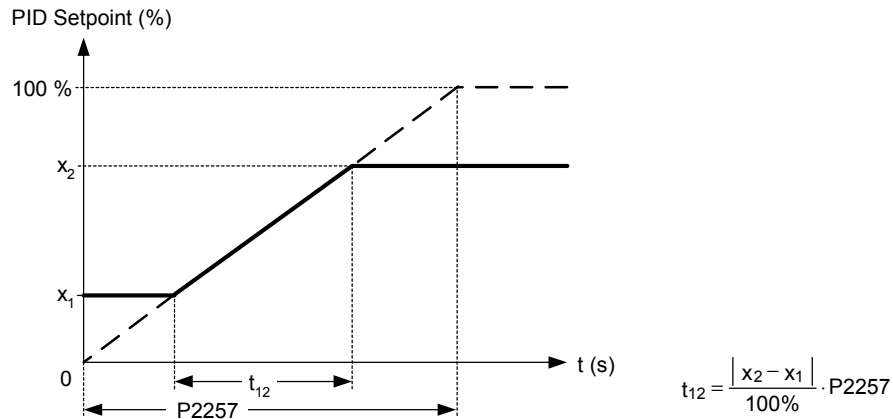

Dependency:

P2200 = 1 (PID control is enabled) disables normal ramp-up time (P1120).

PID ramp time effective only on PID setpoint and only active when PID setpoint is changed or when RUN command is given.

Notice:

Setting the ramp-up time too short may cause the inverter to trip, on overcurrent for example.

P2258	Ramp-down time for PID setpoint	Min: 0.00	Level 2	
	CStat: CUT	Datatype: Float		Unit: s
	P-Group: TECH	Active: Immediately		QuickComm.: No
		Def: 1.00		
		Max: 650.00		

Sets ramp-down time for PID setpoint.

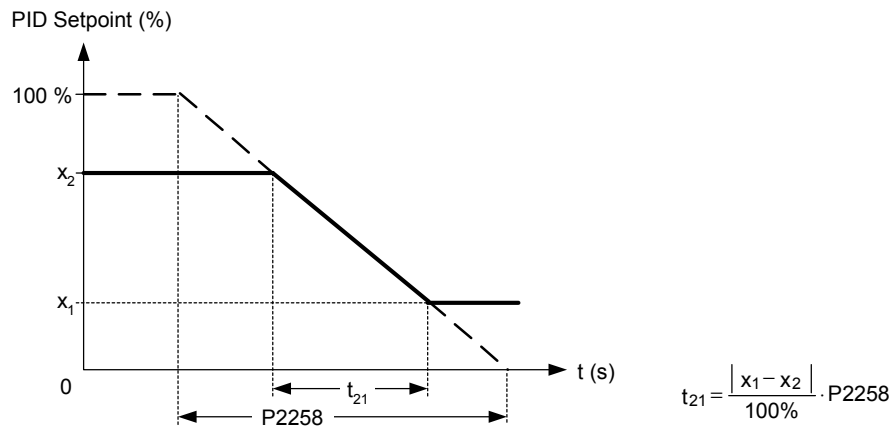

Dependency:

- P2200 = 1 (PID control is enabled) disables normal ramp-up time (P1120).
- PID setpoint ramp effective only on PID setpoint changes.
- P1121 (ramp-down time) and P1135 (OFF3 ramp-down time) define the ramp times used after OFF1 and OFF3 respectively.

Notice:

Setting the ramp-down time too short can cause the inverter to trip on overvoltage (F0002) / overcurrent (F0001).

r2260	CO: PID setpoint after PID-RFG	Min: -	Level 2	
		Datatype: Float		Unit: %
	P-Group: TECH	Def: -		Max: -
		Max: -		

Displays total active PID setpoint after PID-RFG in [%].

Note:

r2260 = 100 % corresponds to 4000 hex

P2261	PID setpoint filter timeconstant	Min: 0.00	Level 3
	CStat: CUT Datatype: Float Unit: s Def: 0.00		
	P-Group: TECH Active: Immediately QuickComm.: No Max: 60.00		

Sets a time constant for smoothing the PID setpoint.

Note:

0 = no smoothing

r2262	CO: Filtered PID setp. after RFG	Min: -	Level 3
	Datatype: Float Unit: % Def: -		
	P-Group: TECH Active: Immediately QuickComm.: No Max: -		

Displays filtered PID setpoint after PID-RFG in [%].

Note:

r2262 = 100 % corresponds to 4000 hex

P2263	PID controller type	Min: 0	Level 3
	CStat: T Datatype: U16 Unit: - Def: 0		
	P-Group: TECH Active: Immediately QuickComm.: No Max: 1		

Sets the PID controller type.

Possible Settings:

- 0 D component on feedback signal
- 1 D component on error signal

P2264[3]	CI: PID feedback	Min: 0:0	Level 2
	CStat: CUT Datatype: U32 Unit: - Def: 755:1		
	P-Group: TECH Active: first confirm QuickComm.: No Max: 4000:0		

Selects the source of the PID feedback signal.

Index:

- P2264[0] : 1st. Command data set (CDS)
- P2264[1] : 2nd. Command data set (CDS)
- P2264[2] : 3rd. Command data set (CDS)

Common Settings:

Parameter	Parameter text	Setting	Meaning
P2200	BI: Enable PID controller	0	PID controller de-activated
		1.0	PID controller always active
		722.x	Digital input x
		BICO	BICO parameter
P2253	CI: PID setpoint	2224	Fixed PID setpoint (PID-FF)
		2250	PID-MOP
		755.0	Analog input 1
		2015.1	USS on BOP link
		2019.1	USS on COM link
		2050.1	CB on COM link
P2264	CI: PID feedback	755.0	Analog input 1
		755.1	Analog input 2

Note:

When analog input is selected, offset and gain can be implemented using parameters P0756 to P0760 (ADC scaling).

P2265	PID feedback filter timeconstant	Min: 0.00	Level 2
	CStat: CUT Datatype: Float Unit: s Def: 0.00		
	P-Group: TECH Active: Immediately QuickComm.: No Max: 60.00		

Defines time constant for PID feedback filter.

r2266	CO: PID filtered feedback	Min: -	Level 2
	Datatype: Float Unit: % Def: -		
	P-Group: TECH Active: Immediately QuickComm.: No Max: -		

Displays PID feedback signal in [%].

Note:

r2266 = 100 % corresponds to 4000 hex

P2267	Max. value for PID feedback	Min: -200.00	Level 3
	CStat: CUT Datatype: Float Unit: % Def: 100.00		
	P-Group: TECH Active: Immediately QuickComm.: No Max: 200.00		

Sets the upper limit for the value of the feedback signal in [%].

Note:

- P2267 = 100 % corresponds to 4000 hex
- When PID is enabled (P2200 = 1) and the signal rises above this value, the inverter will trip with F0222.

P2268	Min. value for PID feedback	Min: -200.00	Level 3
	CStat: CUT Datatype: Float Unit: % Def: 0.00		
	P-Group: TECH Active: Immediately QuickComm.: No Max: 200.00		

Sets lower limit for value of feedback signal in [%].

Note:

- P2268 = 100 % corresponds to 4000 hex
- When PID is enabled (P2200 = 1) and the signal rises below this value, the inverter will trip with F0221.

P2269	Gain applied to PID feedback	Min: 0.00	Level 3
	CStat: CUT Datatype: Float Unit: - Def: 100.00		
	P-Group: TECH Active: Immediately QuickComm.: No Max: 500.00		

Allows the user to scale the PID feedback as a percentage value [%].

A gain of 100.0 % means that feedback signal has not changed from its default value.

P2270	PID feedback function selector	Min: 0	Level 3
	CStat: CUT Datatype: U16 Unit: - Def: 0		
	P-Group: TECH Active: Immediately QuickComm.: No Max: 3		

Applies mathematical functions to the PID feedback signal, allowing multiplication of the result by P2269 (gain applied to PID feedback).

Possible Settings:

- 0 Disabled
- 1 Square root (root(x))
- 2 Square (x*x)
- 3 Cube (x*x*x)

P2271	PID transducer type	Min: 0	Level 2
	CStat: CUT Datatype: U16 Unit: - Def: 0		
	P-Group: TECH Active: Immediately QuickComm.: No Max: 1		

Allows the user to select the transducer type for the PID feedback signal.

Possible Settings:

- 0 Disabled
- 1 Inversion of PID feedback signal

Notice:

It is essential that you select the correct transducer type.

If you are unsure whether 0 or 1 is applicable, you can determine the correct type as follows:

1. Disable the PID function (P2200 = 0).
2. Increase the motor frequency while measuring the feedback signal.
3. If the feedback signal increases with an increase in motor frequency, the PID transducer type should be 0.
4. If the feedback signal decreases with an increase in motor frequency the PID transducer type should be set to 1.

r2272	CO: PID scaled feedback	Min: -	Level 2
	Datatype: Float Unit: % Def: -		
	P-Group: TECH Max: -		

Displays PID scaled feedback signal in [%].

Note:

r2272 = 100 % corresponds to 4000 hex

r2273	CO: PID error	Min: -	Level 2
	Datatype: Float Unit: % Def: -		
	P-Group: TECH Max: -		

Displays PID error (difference) signal between setpoint and feedback signals in [%].

Note:

r2273 = 100 % corresponds to 4000 hex

P2274	PID derivative time			Min: 0.000	Level 2
	CStat: CUT	Datatype: Float	Unit: s	Def: 0.000	
	P-Group: TECH	Active: Immediately	QuickComm.: No	Max: 60.000	

Sets PID derivative time.

P2274 = 0:

The derivative term does not have any effect (it applies a gain of 1).

P2280	PID proportional gain			Min: 0.000	Level 2
	CStat: CUT	Datatype: Float	Unit: -	Def: 3.000	
	P-Group: TECH	Active: Immediately	QuickComm.: No	Max: 65.000	

Allows user to set proportional gain for PID controller.

The PID controller is implemented using the standard model.

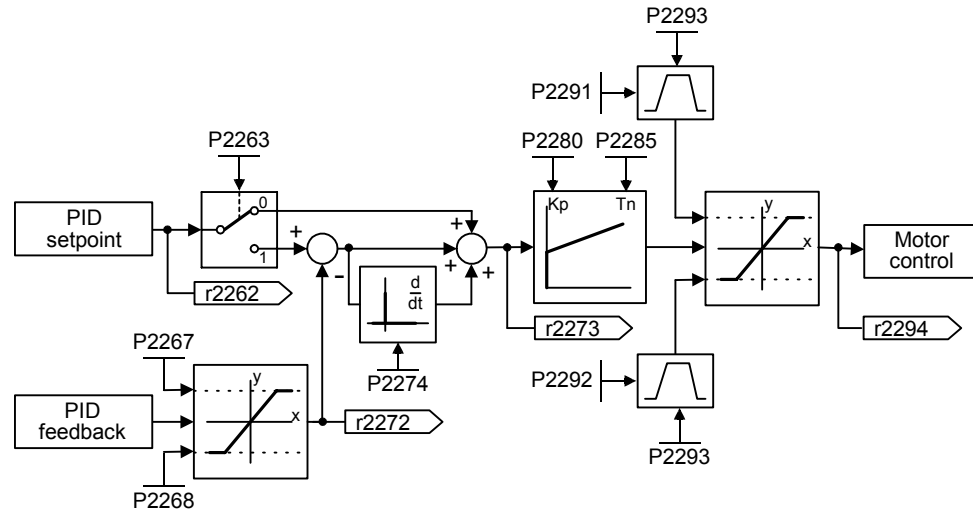

For best results, enable both P and I terms.

Dependency:

P2280 = 0 (P term of PID = 0):

I term acts on the square of the error signal.

P2285 = 0 (I term of PID = 0):

PID controller acts as a P or PD controller respectively.

Note:

- If the system is prone to sudden step changes in the feedback signal, P term should normally be set to a small value (0.5) with a faster I term for optimum performance.
- The D term (P2274) multiplies the difference between the present and previous feedback signal thus accelerating the controller reaction to an error that appears suddenly.
- The D term should be used carefully, since it can cause the controller output to fluctuate as every change in the feedback signal is amplified by the controller derivative action.

P2285	PID integral time			Min: 0.000	Level 2
	CStat: CUT	Datatype: Float	Unit: s	Def: 0.000	
	P-Group: TECH	Active: Immediately	QuickComm.: No	Max: 60.000	

Sets integral time constant for PID controller.

Details:

See P2280 (PID proportional gain).

P2291	PID output upper limit			Min: -200.00	Level 2
	CStat: CUT	Datatype: Float	Unit: %	Def: 100.00	
	P-Group: TECH	Active: Immediately	QuickComm.: No	Max: 200.00	

Sets upper limit for PID controller output in [%].

Dependency:

If F max (P1082) is greater than P2000 (reference frequency), either P2000 or P2291 (PID output upper limit) must be changed to achieve F max.

Note:

P2291 = 100 % corresponds to 4000 hex (as defined by P2000 (reference frequency)).

P2292	PID output lower limit	Min: -200.00	Level 2	
	CStat: CUT	Datatype: Float		Unit: %
	P-Group: TECH	Active: Immediately		QuickComm.: No
		Def: 0.00		
		Max: 200.00		

Sets lower limit for the PID controller output in [%].

Dependency:

A negative value allows bipolar operation of PID controller.

Note:

P2292 = 100 % corresponds to 4000 hex

P2293	Ramp-up /-down time of PID limit	Min: 0.00	Level 3	
	CStat: CUT	Datatype: Float		Unit: s
	P-Group: TECH	Active: Immediately		QuickComm.: No
		Def: 1.00		
		Max: 100.00		

Sets maximum ramp rate on output of PID.

When PI is enabled, the output limits are ramped up from 0 to the limits set in P2291 (PID output upper limit) and P2292 (PID output lower limit). Limits prevent large step changes appearing on the output of the PID when the inverter is started. Once the limits have been reached, the PID controller output is instantaneous.

These ramp times are used whenever a RUN command is issued.

Note:

If an OFF1 or OFF 3 are issued, the inverter output frequency ramps down as set in P1121 (ramp-down time) or P1135 (OFF3 ramp-down time).

r2294	CO: Act. PID output	Min: -	Level 2	
		Datatype: Float		Unit: %
	P-Group: TECH			Def: -
		Max: -		

Displays PID output in [%]

Note:

r2294 = 100 % corresponds to 4000 hex

3.36 Staging

P2370[3]	Motor staging stop mode	Min: 0	Level 3	
	CStat: CT	Datatype: U16		Unit: -
	P-Group: TECH	Active: Immediately		QuickComm.: No
		Def: 0		
		Max: 1		

Selects stop mode for external motors when motor staging is in use.

Possible Settings:

- 0 Normal stop
- 1 Sequence stop

Index:

- P2370[0] : 1st. Drive data set (DDS)
- P2370[1] : 2nd. Drive data set (DDS)
- P2370[2] : 3rd. Drive data set (DDS)

P2371[3]	Motor staging configuration			Min: 0	Level 3
	CStat: CT	Datatype: U16	Unit: -	Def: 0	
	P-Group: TECH	Active: Immediately	QuickComm.: No	Max: 8	

Selects configuration of external motors (M1, M2, M3) used for motor staging feature.

Possible Settings:

- 0 Motor staging disabled
- 1 M1 = 1X, M2 = , M3 =
- 2 M1 = 1X, M2 = 1X, M3 =
- 3 M1 = 1X, M2 = 2X, M3 =
- 4 M1 = 1X, M2 = 1X, M3 = 1X
- 5 M1 = 1X, M2 = 1X, M3 = 2X
- 6 M1 = 1X, M2 = 2X, M3 = 3X
- 7 M1 = 1X, M2 = 1X, M3 = 3X
- 8 M1 = 1X, M2 = 2X, M3 = 3X

Index:

- P2371[0] : 1st. Drive data set (DDS)
- P2371[1] : 2nd. Drive data set (DDS)
- P2371[2] : 3rd. Drive data set (DDS)



Caution:

For this kind of motor application it is mandatory to disable negative frequency setpoint!

Details:

Motor staging allows the control of up to 3 additional staged pumps or fans, based on a PID control system. The complete system consists of one pump controlled by the inverter with up to 3 further pumps / fans controlled from contactors or motor starters. The contactors or motor starter are controlled by outputs from the inverter. The diagram below shows a typical pumping system. A similar system could be set up using fans and air ducts, instead of pumps and pipes.

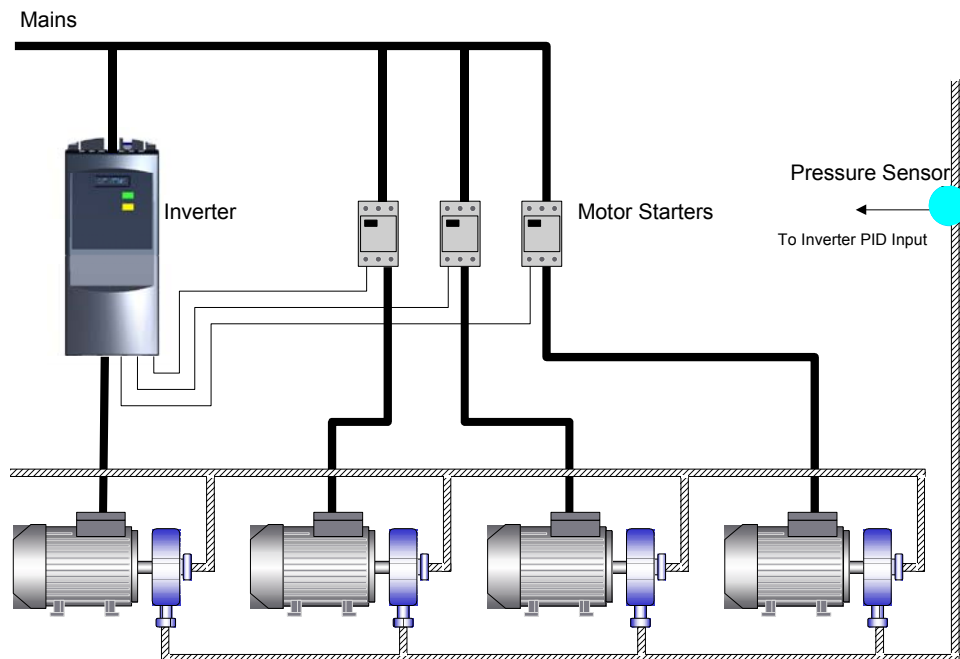

By default the motor starters are controlled from relay outputs (DOUT). In the text below, the following terminology will be used:

- MV - Variable speed (Inverter controlled motor)
- M1 - Motor switched with relay 1 (DOUT 1)
- M2 - Motor switched with relay 2 (DOUT 2)
- M3 - Motor switched with relay 3 (DOUT 3)

Staging: The process of starting one of the fixed speed motors.
 De-staging: The process of stopping one of the fixed speed motors.

When the inverter is running at maximum frequency, and the PID feedback indicates that a higher frequency is required, the inverter switches on (stages) one of the relay controlled motors M1 to M3. At the same time, to keep the controlled variable as constant as possible, the inverter must ramp down to minimum frequency. Therefore, during the staging process, PID control must be suspended (see P2378 and diagram below).

Staging of external motors (M1, M2, M3)

		1.	2.	3.	4.	5.	6.	7.	Switch-on
P2371 =	0	-	-	-	-	-	-	-	-
	1	-	M1	M1	M1	M1	M1	M1	M1
	2	-	M1	M1+M2	M1+M2	M1+M2	M1+M2	M1+M2	M1+M2
	3	-	M1	M2	M1+M2	M1+M2	M1+M2	M1+M2	M1+M2
	4	-	M1	M1+M2	M1+M2+M3	M1+M2+M3	M1+M2+M3	M1+M2+M3	M1+M2+M3
	5	-	M1	M3	M1+M3	M1+M2+M3	M1+M2+M3	M1+M2+M3	M1+M2+M3
	6	-	M1	M2	M1+M2	M2+M3	M1+M2+M3	M1+M2+M3	M1+M2+M3
	7	-	M1	M1+M2	M3	M1+M3	M1+M2+M3	M1+M2+M3	M1+M2+M3
	8	-	M1	M2	M3	M1+M3	M2+M3	M1+M2+M3	M1+M2+M3

When the inverter is running at minimum frequency, and the PID feedback indicates that a lower frequency is required, the inverter switches off (de-stages) one of the relay controlled motors M1 to M3. In this case, the inverter must ramp from minimum frequency to maximum frequency outside of PID control (see P2378 and diagram below).

Destaging of external motors (M1, M2, M3)

		1.	2.	3.	4.	5.	6.	7.	Switch-off
P2371 =	0	-	-	-	-	-	-	-	-
	1	M1	-	-	-	-	-	-	-
	2	M1+M2	M1	-	-	-	-	-	-
	3	M1+M2	M2	M1	-	-	-	-	-
	4	M1+M2+M3	M2+M1	M1	-	-	-	-	-
	5	M1+M2+M3	M3+M1	M3	M1	-	-	-	-
	6	M1+M2+M3	M3+M2	M2+M1	M2	M1	-	-	-
	7	M1+M2+M3	M3+M1	M3	M2+M1	M1	-	-	-
	8	M1+M2+M3	M3+M2	M3+M1	M3	M2	M1	-	-

P2372[3]	Motor staging cycling	Min: 0	Level 3	
	CStat: CT	Datatype: U16		Unit: -
	P-Group: TECH	Active: first confirm		QuickComm.: No
				Def: 0
		Max: 1		

Enables motor cycling for the motor staging feature.

When enabled, the motor selected for staging/destaging is based on the hours run counter P2380. When staging, the motor with the least hours is switched on. When destaging, the motor with most hours is switched off.

If staged motors are different sizes the the choice of motor is first based on required motor size, and then if there is still a choice, on hours run.

Possible Settings:

- 0 Disabled
- 1 Enabled

Index:

- P2372[0] : 1st. Drive data set (DDS)
- P2372[1] : 2nd. Drive data set (DDS)
- P2372[2] : 3rd. Drive data set (DDS)

P2373[3]	Motor staging hysteresis	Min: 0.0	Level 3	
	CStat: CUT	Datatype: Float		Unit: %
	P-Group: TECH	Active: Immediately		QuickComm.: No
				Def: 20.0
		Max: 200.0		

P2373 as a percentage of PID setpoint that PID error P2273 must be exceeded before staging delay starts.

Index:

- P2373[0] : 1st. Drive data set (DDS)
- P2373[1] : 2nd. Drive data set (DDS)
- P2373[2] : 3rd. Drive data set (DDS)

Note:

The value of this parameter must always be smaller than delay override lockout timer P2377.

P2374[3]	Motor staging delay	Min: 0	Level 3	
	CStat: CUT	Datatype: U16		Unit: s
	P-Group: TECH	Active: Immediately		QuickComm.: No

Def: 30
Max: 650

Time that PID error P2273 must exceed motor staging hysteresis P2373 before staging occurs.

Index:

- P2374[0] : 1st. Drive data set (DDS)
- P2374[1] : 2nd. Drive data set (DDS)
- P2374[2] : 3rd. Drive data set (DDS)

P2375[3]	Motor destaging delay	Min: 0	Level 3	
	CStat: CUT	Datatype: U16		Unit: s
	P-Group: TECH	Active: Immediately		QuickComm.: No

Def: 30
Max: 650

Time that PID error P2273 must exceed motor staging hysteresis P2373 before destaging occurs.

Index:

- P2375[0] : 1st. Drive data set (DDS)
- P2375[1] : 2nd. Drive data set (DDS)
- P2375[2] : 3rd. Drive data set (DDS)

P2376[3]	Motor staging delay override	Min: 0.0	Level 3	
	CStat: CUT	Datatype: Float		Unit: %
	P-Group: TECH	Active: Immediately		QuickComm.: No

Def: 25.0
Max: 200.0

P2376 as a percentage of PID setpoint. When the PID error P2273 exceeds this value, a motor is staged / destaged irrespective of the delay timers.

Index:

- P2376[0] : 1st. Drive data set (DDS)
- P2376[1] : 2nd. Drive data set (DDS)
- P2376[2] : 3rd. Drive data set (DDS)

Note:

The value of this parameter must always be larger than staging hysteresis P2373.

P2377[3]	Motor staging lockout timer	Min: 0	Level 3	
	CStat: CUT	Datatype: U16		Unit: s
	P-Group: TECH	Active: Immediately		QuickComm.: No

Def: 30
Max: 650

Time for which delay override is prevented after a motor has been staged or destaged.

This prevents a second staging event immediately after a first, being caused by the transient conditions after the first staging event.

Index:

- P2377[0] : 1st. Drive data set (DDS)
- P2377[1] : 2nd. Drive data set (DDS)
- P2377[2] : 3rd. Drive data set (DDS)

P2378[3]	Motor staging frequency f_{st} [%]			Min: 0.0	Level 3
	CStat: CUT	Datatype: Float	Unit: %	Def: 50.0	
	P-Group: TECH	Active: Immediately	QuickComm.: No	Max: 120.0	

The frequency as a percentage of max. frequency. During a (de) staging event, as the inverter ramps from maximum to minimum frequency (or vice versa) this is the frequency at which the relay (DOUT) is switched. This is illustrated by the following diagrams.

Staging:

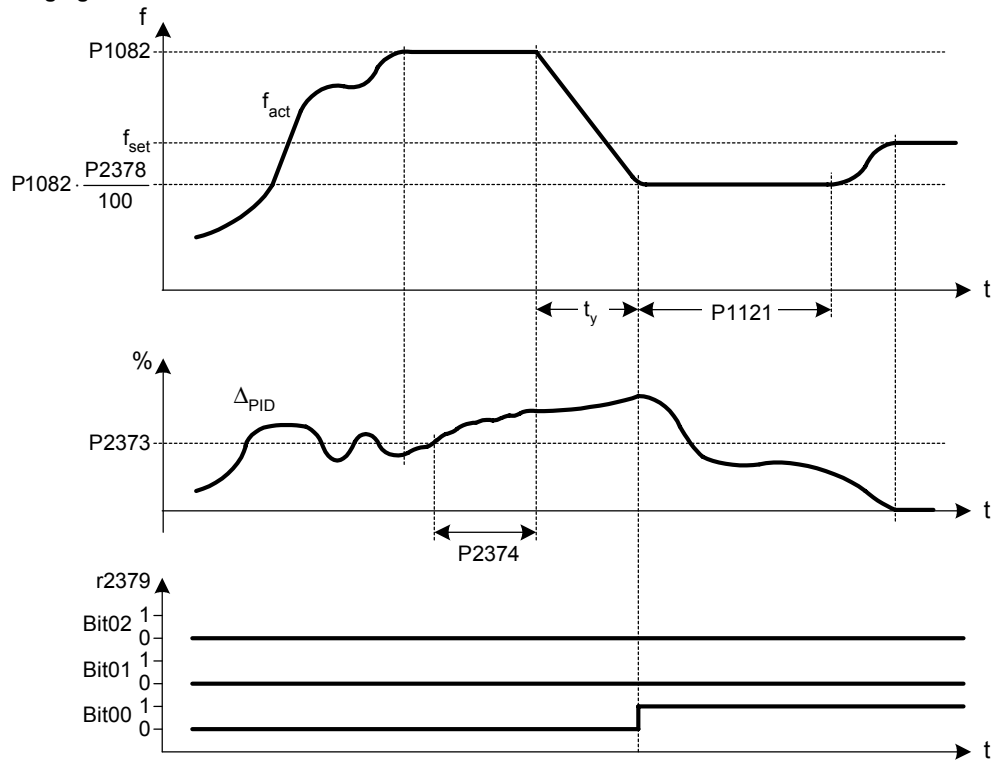

Condition for staging:

- (a) $f_{act} \geq P1082$
- (b) $\Delta_{PID} \geq P2373$
- (c) $t_{(a)(b)} > P2374$

$$t_y = \left(1 - \frac{P2378}{100}\right) \cdot P1121$$

Destaging:

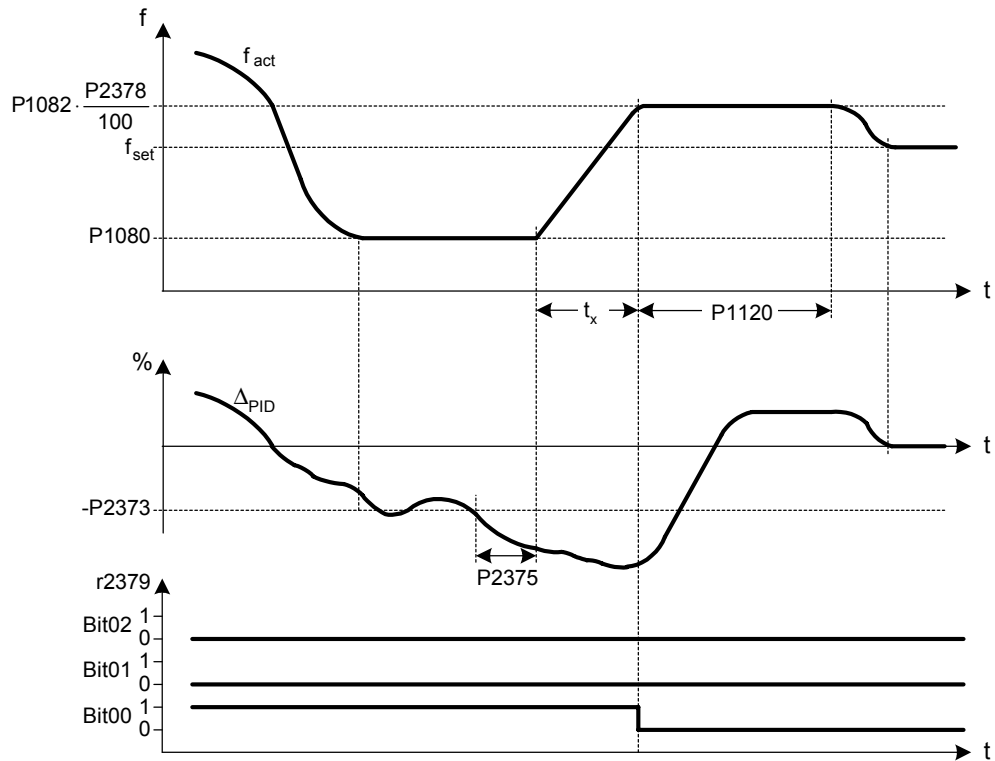

Condition for destaging:

- (a) $f_{act} \leq P1080$
- (b) $\Delta_{PID} \leq -P2373$
- (c) $t_{(a)(b)} > P2375$

$$t_x = \left(\frac{P2378}{100} - \frac{P1080}{P1082} \right) \cdot P1120$$

Index:

- P2378[0] : 1st. Drive data set (DDS)
- P2378[1] : 2nd. Drive data set (DDS)
- P2378[2] : 3rd. Drive data set (DDS)

r2379	CO/BO: Motor staging status word	Min: -	Level
	Datatype: U16 Unit: -	Def: -	3
P-Group: TECH		Max: -	

Output word from the motor staging feature that allows external connections to be made. Bit 0 switches on Motor 1. Bit 1 switches on Motor 2. Bit 2 switches on Motor 3.

Bitfields:

Bit00	Start motor 1	0 NO	1 YES
Bit01	Start motor 2	0 NO	1 YES
Bit02	Start motor 3	0 NO	1 YES

P2380[3]	Motor staging hours run	Min: 0.0	Level
	CStat: CUT Datatype: Float Unit: h	Def: 0.0	3
P-Group: TECH Active: first confirm QuickComm.: No		Max: 0.0	

Displays hours run for external motors. To reset the running hours, set the value to zero, any other value is ignored.

Index:

- P2380[0] : Motor 1 hrs run
- P2380[1] : Motor 2 hrs run
- P2380[2] : Motor 3 hrs run

Example:

- P2380 = 0.1 ==> 6 min
- P2380 = 1.0 ==> 60 min = 1 h

3.37 Energy saving mode

P2390	Energy saving setpoint	Min: -200.00	Level
	CStat: CUT	Datatype: Float	Unit: %
	P-Group: TECH	Active: Immediately	QuickComm.: No
		Def: 0	3
		Max: 200.00	

When the inverter under PID control drops below energy saving setpoint, the energy saving timer P2391 is started. When the energy saving timer has expired, the inverter is ramped down to stop and enters energy saving mode (see diagram below).

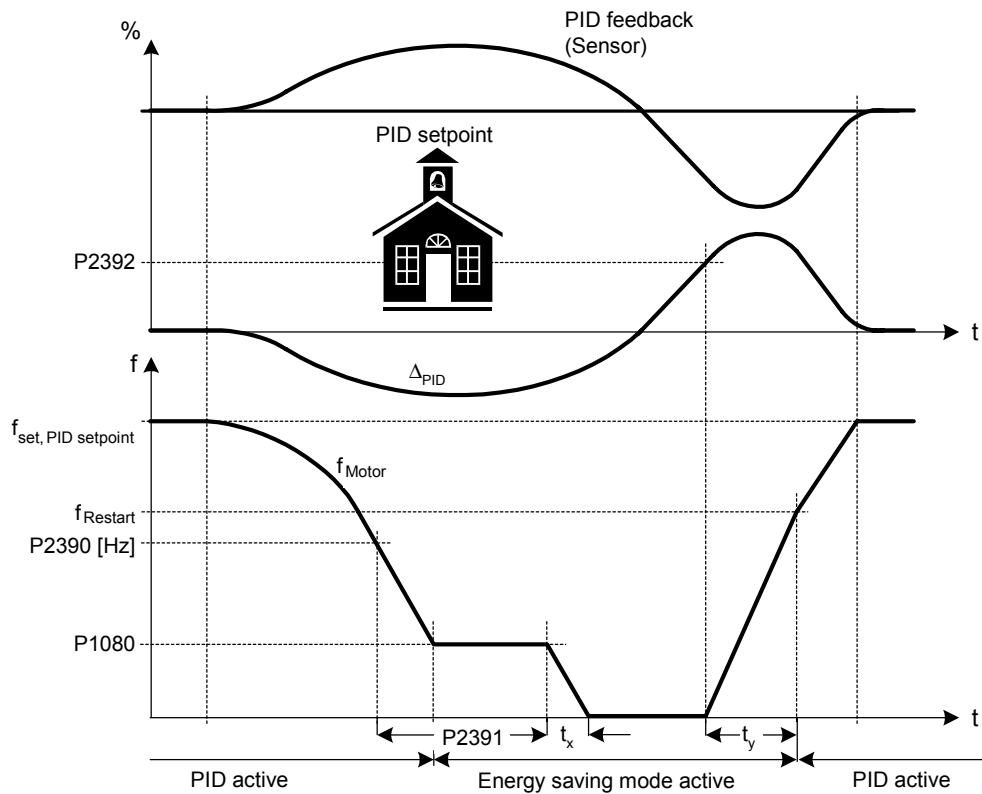
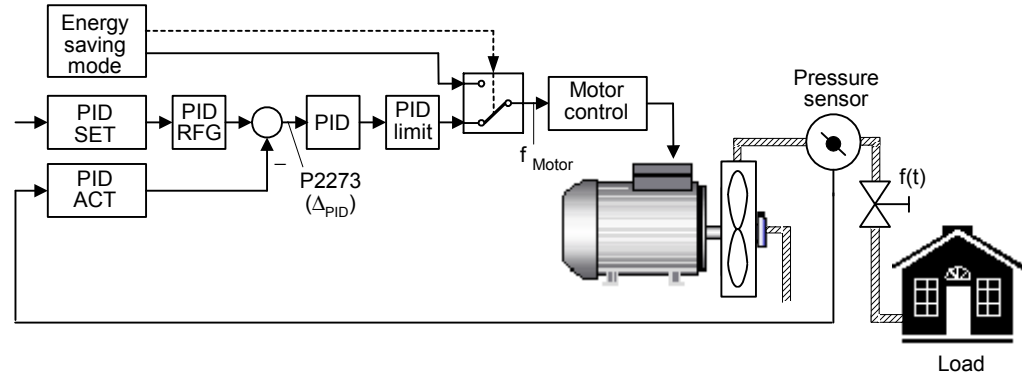

$$f_{Restart} = P2000 \cdot \frac{P2390 + 5\%}{100\%}$$

$$P2390 \text{ [Hz]} = P2000 \cdot \frac{P2390}{100\%}$$

$$t_x = \frac{P1080}{P1082} \cdot P1121$$

$$t_y = \frac{f_{Restart}}{P1082} \cdot P1120$$

Note:

If energy saving setpoint is 0, the energy saving function is disabled.

Notice:

Energy saving mode is an added feature to enhance PID functionality, and switches of the motor when the inverter is running at low setpoint.

Note that this is an independent function from staging, although it can be used together with staging.

P2391	Energy saving timer			Min: 0	Level 3
	CStat: CT	Datatype: U16	Unit: s	Def: 0	
	P-Group: TECH	Active: Immediately	QuickComm.: No	Max: 254	

When the energy saving timer P2391 has expired, the inverter is ramped down to stop and enters energy saving mode (see description and diagram of P2390).

P2392	Energy saving restart setpoint			Min: -200.00	Level 3
	CStat: CT	Datatype: Float	Unit: %	Def: 0	
	P-Group: TECH	Active: Immediately	QuickComm.: No	Max: 200.00	

While in energy saving mode, the PID controller continues to generate the error P2273 - once this reaches the restart point P2392 the inverter immediately ramps to the setpoint calculated by the PID controller (see description and diagram of P2390).

3.38 Free function blocks (FFB)

P2800	Enable FFBs			Min: 0	Level 3
	CStat: CUT	Datatype: U16	Unit: -	Def: 0	
	P-Group: TECH	Active: first confirm	QuickComm.: No	Max: 1	

Free function blocks (FFB) are enabled in two steps.

1. Parameter P2800 enables all free function blocks , normally (P2800 = 1).
2. Parameters P2801 and P2802 respectively, enable each free function block individually (P2801[x] > 0 oder P2802[x] > 0).

Possible Settings:

- 0 Disable
- 1 Enable

Dependency:

All active function blocks will be calculated in every 132 ms.

r2811	BO: AND 1	Datatype: U16	Unit: -	Min: - Def: - Max: -	Level 3
	P-Group: TECH				

Output of AND 1 element. Displays and logic of bits defined in P2810[0], P2810[1].

Dependency:
P2801[0] is active level for the AND element.

P2812[2]	BI: AND 2	Datatype: U32	Unit: -	Min: 0:0 Def: 0:0 Max: 4000:0	Level 3
	CStat: CUT P-Group: TECH	Active: first confirm	QuickComm.: No		

P2812[0], 2812[1] define inputs of AND 2 element, output is P2813.

Index:
P2812[0] : Binector input 0 (BI 0)
P2812[1] : Binector input 1 (BI 1)

Dependency:
P2801[1] is active level for the AND element.

r2813	BO: AND 2	Datatype: U16	Unit: -	Min: - Def: - Max: -	Level 3
	P-Group: TECH				

Output of AND 2 element. Displays and logic of bits defined in P2812[0], P2812[1].

Dependency:
P2801[1] is active level for the AND element.

P2814[2]	BI: AND 3	Datatype: U32	Unit: -	Min: 0:0 Def: 0:0 Max: 4000:0	Level 3
	CStat: CUT P-Group: TECH	Active: first confirm	QuickComm.: No		

P2814[0], P2814[1] define inputs of AND 3 element, output is P2815.

Index:
P2814[0] : Binector input 0 (BI 0)
P2814[1] : Binector input 1 (BI 1)

Dependency:
P2801[2] is active level for the AND element.

r2815	BO: AND 3	Datatype: U16	Unit: -	Min: - Def: - Max: -	Level 3
	P-Group: TECH				

Output of AND 3 element. Displays and logic of bits defined in P2814[0], P2814[1].

Dependency:
P2801[2] is active level for the AND element.

P2816[2]	BI: OR 1	Datatype: U32	Unit: -	Min: 0:0 Def: 0:0 Max: 4000:0	Level 3
	CStat: CUT P-Group: TECH	Active: first confirm	QuickComm.: No		

P2816[0], P2816[1] define inputs of OR 1 element, output is P2817.

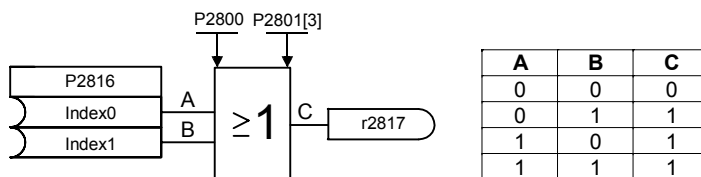

Index:
P2816[0] : Binector input 0 (BI 0)
P2816[1] : Binector input 1 (BI 1)

Dependency:
P2801[3] is active level for the OR element.

r2817	BO: OR 1	Datatype: U16	Unit: -	Min: - Def: - Max: -	Level 3
	P-Group: TECH				

Output of OR 1 element. Displays or logic of bits defined in P2816[0], P2816[1].

Dependency:
P2801[3] is active level for the OR element.

P2818[2]	BI: OR 2	Min: 0:0	Level 3	
	CStat: CUT	Datatype: U32		Def: 0:0
	P-Group: TECH	Active: first confirm		QuickComm.: No

P2818[0], P2818[1] define inputs of OR 2 element, output is P2819.

Index:

P2818[0] : Binector input 0 (BI 0)
P2818[1] : Binector input 1 (BI 1)

Dependency:

P2801[4] is active level for the OR element.

r2819	BO: OR 2	Min: -	Level 3	
	Datatype: U16	Unit: -		Def: -
	P-Group: TECH	Active: first confirm		QuickComm.: No

Output of OR 2 element. Displays or logic of bits defined in P2818[0], P2818[1].

Dependency:

P2801[4] is active level for the OR element.

P2820[2]	BI: OR 3	Min: 0:0	Level 3	
	CStat: CUT	Datatype: U32		Def: 0:0
	P-Group: TECH	Active: first confirm		QuickComm.: No

P2820[0], P2820[1] define inputs of OR 3 element, output is P2821.

Index:

P2820[0] : Binector input 0 (BI 0)
P2820[1] : Binector input 1 (BI 1)

Dependency:

P2801[5] is active level for the OR element.

r2821	BO: OR 3	Min: -	Level 3	
	Datatype: U16	Unit: -		Def: -
	P-Group: TECH	Active: first confirm		QuickComm.: No

Output of OR 3 element. Displays or logic of bits defined in P2820[0], P2820[1].

Dependency:

P2801[5] is active level for the OR element.

P2822[2]	BI: XOR 1	Min: 0:0	Level 3	
	CStat: CUT	Datatype: U32		Def: 0:0
	P-Group: TECH	Active: first confirm		QuickComm.: No

P2822[0], P2822[1] define inputs of XOR 1 element, output is P2823.

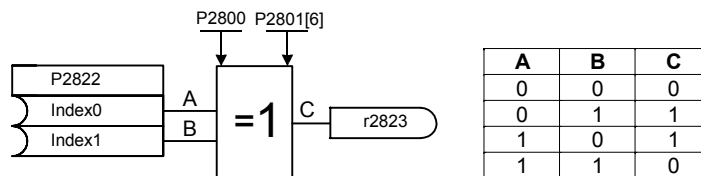

Index:

P2822[0] : Binector input 0 (BI 0)
P2822[1] : Binector input 1 (BI 1)

Dependency:

P2801[6] is active level for the XOR element.

r2823	BO: XOR 1	Min: -	Level 3	
	Datatype: U16	Unit: -		Def: -
	P-Group: TECH	Active: first confirm		QuickComm.: No

Output of XOR 1 element. Displays exclusive-or logic of bits defined in P2822[0], P2822[1].

Dependency:

P2801[6] is active level for the XOR element.

P2824[2]	BI: XOR 2	Min: 0:0	Level 3	
	CStat: CUT	Datatype: U32		Def: 0:0
	P-Group: TECH	Active: first confirm		QuickComm.: No

P2824[0], P2824[1] define inputs of XOR 2 element, output is P2825.

Index:

P2824[0] : Binector input 0 (BI 0)
P2824[1] : Binector input 1 (BI 1)

Dependency:

P2801[7] is active level for the XOR element.

r2825	BO: XOR 2	Datatype: U16	Unit: -	Min: - Def: - Max: -	Level 3
	P-Group: TECH				

Output of XOR 2 element. Displays exclusive-or logic of bits defined in P2824[0], P2824[1].

Dependency:
P2801[7] is active level for the XOR element.

P2826[2]	BI: XOR 3	Datatype: U32	Unit: -	Min: 0:0 Def: 0:0 Max: 4000:0	Level 3
	CStat: CUT P-Group: TECH	Active: first confirm	QuickComm.: No		

P2826[0], P2826[1] define inputs of XOR 3 element, output is P2827.

Index:
P2826[0] : Binector input 0 (BI 0)
P2826[1] : Binector input 1 (BI 1)

Dependency:
P2801[8] is active level for the XOR element.

r2827	BO: XOR 3	Datatype: U16	Unit: -	Min: - Def: - Max: -	Level 3
	P-Group: TECH				

Output of XOR 3 element. Displays exclusive-or logic of bits defined in P2826[0], P2826[1].

Dependency:
P2801[8] is active level for the XOR element.

P2828	BI: NOT 1	Datatype: U32	Unit: -	Min: 0:0 Def: 0:0 Max: 4000:0	Level 3
	CStat: CUT P-Group: TECH	Active: first confirm	QuickComm.: No		

P2828 defines input of NOT 1 element, output is P2829.

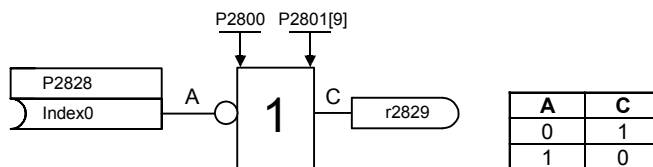

Dependency:
P2801[9] is active level for the NOT element.

r2829	BO: NOT 1	Datatype: U16	Unit: -	Min: - Def: - Max: -	Level 3
	P-Group: TECH				

Output of NOT 1 element. Displays not logic of bit defined in P2828.

Dependency:
P2801[9] is active level for the NOT element.

P2830	BI: NOT 2	Datatype: U32	Unit: -	Min: 0:0 Def: 0:0 Max: 4000:0	Level 3
	CStat: CUT P-Group: TECH	Active: first confirm	QuickComm.: No		

P2830 defines input of NOT 2 element, output is P2831.

Dependency:
P2801[10] is active level for the NOT element.

r2831	BO: NOT 2	Datatype: U16	Unit: -	Min: - Def: - Max: -	Level 3
	P-Group: TECH				

Output of NOT 2 element. Displays not logic of bit defined in P2830.

Dependency:
P2801[10] is active level for the NOT element.

P2832	BI: NOT 3	Datatype: U32	Unit: -	Min: 0:0 Def: 0:0 Max: 4000:0	Level 3
	CStat: CUT P-Group: TECH	Active: first confirm	QuickComm.: No		

P2832 defines input of NOT 3 element, output is P2833.

Dependency:
P2801[11] is active level for the NOT element.

r2833	BO: NOT 3	Datatype: U16	Unit: -	Min: - Def: - Max: -	Level 3
	P-Group: TECH				

Output of NOT 3 element. Displays not logic of bit defined in P2832.

Dependency:
P2801[11] is active level for the NOT element.

P2834[4]	BI: D-FF 1			Min: 0:0	Level 3
	CStat: CUT	Datatype: U32	Unit: -	Def: 0:0	
	P-Group: TECH	Active: first confirm	QuickComm.: No	Max: 4000:0	

P2834[0], P2834[1], P2834[2], P2834[3] define inputs of D-FlipFlop 1, outputs are P2835, P2836.

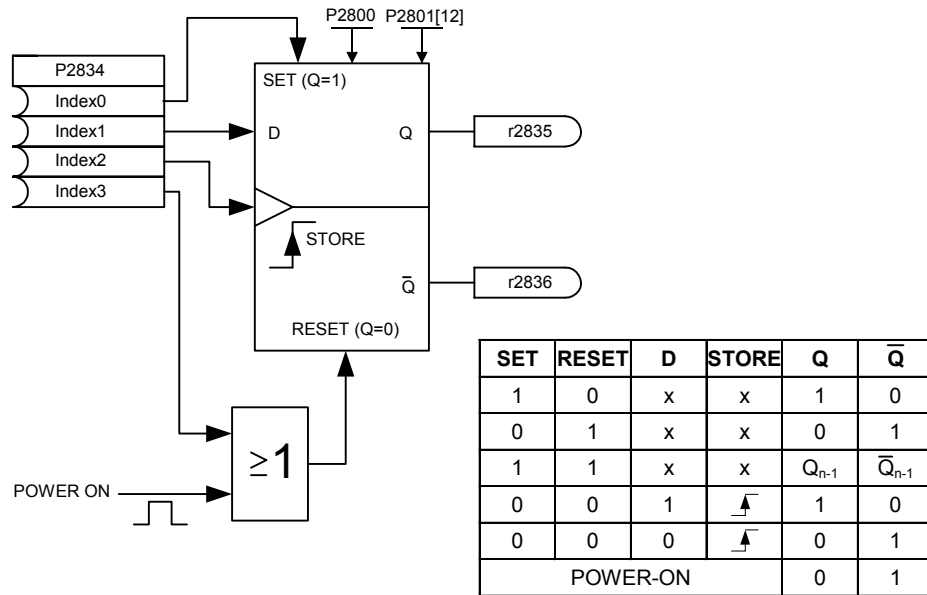

Index:

- P2834[0] : Binector input: Set
- P2834[1] : Binector input: D input
- P2834[2] : Binector input: Store pulse
- P2834[3] : Binector input: Reset

Dependency:

P2801[12] is active level for the D-FlipFlop.

r2835	BO: Q D-FF 1			Min: -	Level 3
	P-Group: TECH	Datatype: U16	Unit: -	Def: -	
				Max: -	

Displays output of D-FlipFlop 1, inputs are defined in P2834[0], P2834[1], P2834[2], P2834[3]

Dependency:

P2801[12] is active level for the D-FlipFlop.

r2836	BO: NOT-Q D-FF 1			Min: -	Level 3
	P-Group: TECH	Datatype: U16	Unit: -	Def: -	
				Max: -	

Displays Not-output of D-FlipFlop 1, inputs are defined in P2834[0], P2834[1], P2834[2], P2834[3]

Dependency:

P2801[12] is active level for the D-FlipFlop.

P2837[4]	BI: D-FF 2			Min: 0:0	Level 3
	CStat: CUT	Datatype: U32	Unit: -	Def: 0:0	
	P-Group: TECH	Active: first confirm	QuickComm.: No	Max: 4000:0	

P2837[0], P2837[1], P2837[2], P2837[3] define inputs of D-FlipFlop 2, outputs are P2838, 2839.

Index:

- P2837[0] : Binector input: Set
- P2837[1] : Binector input: D input
- P2837[2] : Binector input: Store pulse
- P2837[3] : Binector input: Reset

Dependency:

P2801[13] is active level for the D-FlipFlop.

r2838	BO: Q D-FF 2	Datatype: U16	Unit: -	Min: -	Level 3
	P-Group: TECH			Def: - Max: -	

Displays output of D-FlipFlop 2, inputs are defined in P2837[0], P2837[1], P2837[2], P2837[3]

Dependency:
P2801[13] is active level for the D-FlipFlop.

r2839	BO: NOT-Q D-FF 2	Datatype: U16	Unit: -	Min: -	Level 3
	P-Group: TECH			Def: - Max: -	

Displays Not-output of D-FlipFlop 2, inputs are defined in P2837[0], P2837[1], P2837[2], P2837[3]

Dependency:
P2801[13] is active level for the D-FlipFlop.

P2840[2]	BI: RS-FF 1	Datatype: U32	Unit: -	Min: 0:0	Level 3
	CStat: CUT	Active: first confirm	QuickComm.: No	Def: 0:0	
	P-Group: TECH			Max: 4000:0	

P2840[0], P2840[1] define inputs of RS-FlipFlop 1, outputs are P2841, P2842.

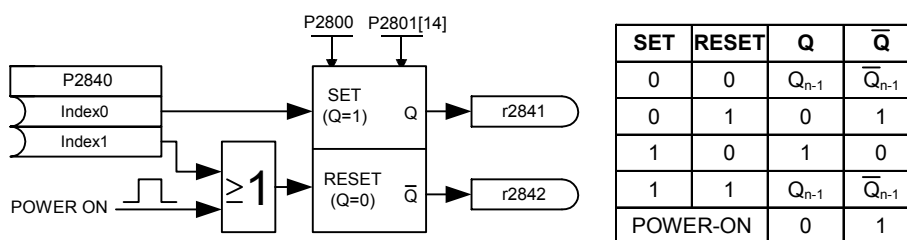

Index:
P2840[0] : Binector input: Set
P2840[1] : Binector input: Reset

Dependency:
P2801[14] is active level for the RS-FlipFlop.

r2841	BO: Q RS-FF 1	Datatype: U16	Unit: -	Min: -	Level 3
	P-Group: TECH			Def: - Max: -	

Displays output of RS-FlipFlop 1, inputs are defined in P2840[0], P2840[1]

Dependency:
P2801[14] is active level for the RS-FlipFlop.

r2842	BO: NOT-Q RS-FF 1	Datatype: U16	Unit: -	Min: -	Level 3
	P-Group: TECH			Def: - Max: -	

Displays Not-output of RS-FlipFlop 1, inputs are defined in P2840[0], P2840[1]

Dependency:
P2801[14] is active level for the RS-FlipFlop.

P2843[2]	BI: RS-FF 2	Datatype: U32	Unit: -	Min: 0:0	Level 3
	CStat: CUT	Active: first confirm	QuickComm.: No	Def: 0:0	
	P-Group: TECH			Max: 4000:0	

P2843[0], P2843[1] define inputs of RS-FlipFlop 2, outputs are P2844, P2845.

Index:
P2843[0] : Binector input: Set
P2843[1] : Binector input: Reset

Dependency:
P2801[15] is active level for the RS-FlipFlop.

r2844	BO: Q RS-FF 2	Datatype: U16	Unit: -	Min: -	Level 3
	P-Group: TECH			Def: - Max: -	

Displays output of RS-FlipFlop 2, inputs are defined in P2843[0], P2843[1]

Dependency:
P2801[15] is active level for the RS-FlipFlop.

r2845	BO: NOT-Q RS-FF 2	Datatype: U16	Unit: -	Min: -	Level 3
	P-Group: TECH			Def: - Max: -	

Displays Not-output of RS-FlipFlop 2, inputs are defined in P2843[0], P2843[1]

Dependency:

P2801[15] is active level for the RS-FlipFlop.

P2846[2]	BI: RS-FF 3	Datatype: U32	Unit: -	Min: 0:0	Level 3
	CStat: CUT	Active: first confirm	QuickComm.: No	Def: 0:0 Max: 4000:0	

P2846[0], P2846[1] define inputs of RS-FlipFlop 3, outputs are P2847, P2848.

Index:

P2846[0] : Binector input: Set
P2846[1] : Binector input: Reset

Dependency:

P2801[16] is active level for the RS-FlipFlop.

r2847	BO: Q RS-FF 3	Datatype: U16	Unit: -	Min: -	Level 3
	P-Group: TECH			Def: - Max: -	

Displays output of RS-FlipFlop 3, inputs are defined in P2846[0], P2846[1]

Dependency:

P2801[16] is active level for the RS-FlipFlop.

r2848	BO: NOT-Q RS-FF 3	Datatype: U16	Unit: -	Min: -	Level 3
	P-Group: TECH			Def: - Max: -	

Displays Not-output of RS-FlipFlop 3, inputs are defined in P2846[0], P2846[1]

Dependency:

P2801[16] is active level for the RS-FlipFlop.

P2849	BI: Timer 1	Datatype: U32	Unit: -	Min: 0:0	Level 3
	CStat: CUT	Active: first confirm	QuickComm.: No	Def: 0:0	
	P-Group: TECH			Max: 4000:0	

Define input signal of timer 1. P2849, P2850, P2851 are the inputs of the timer, outputs are P2852, P2853.

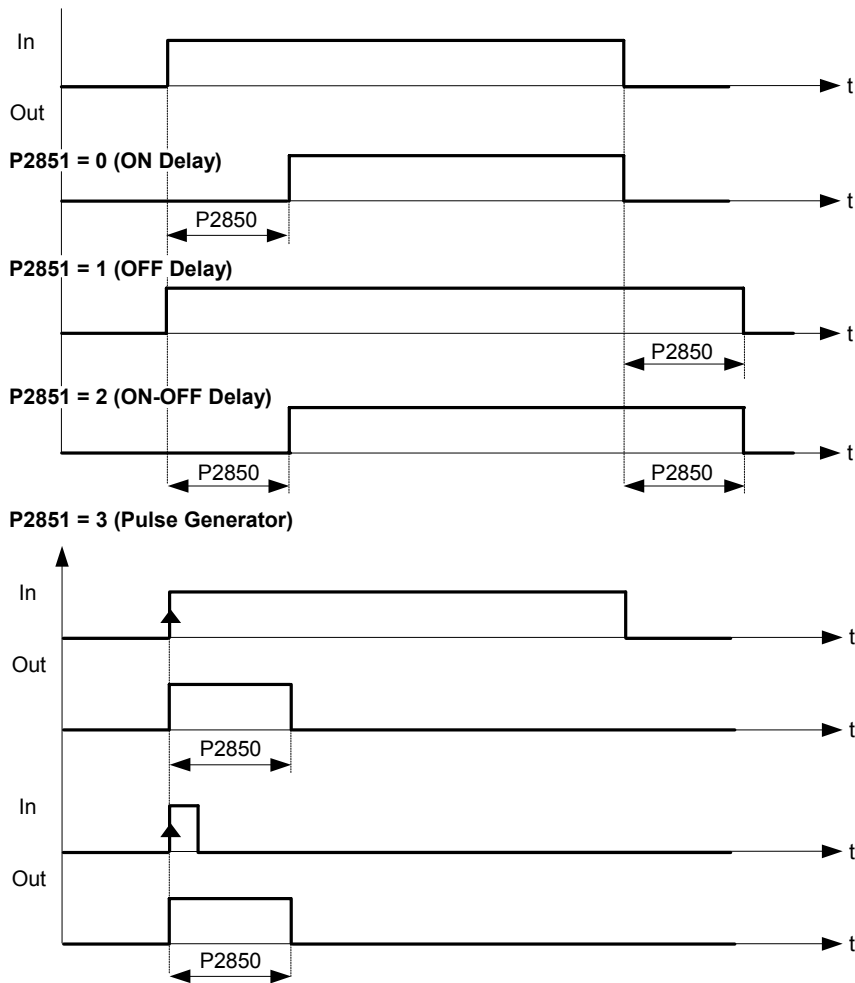
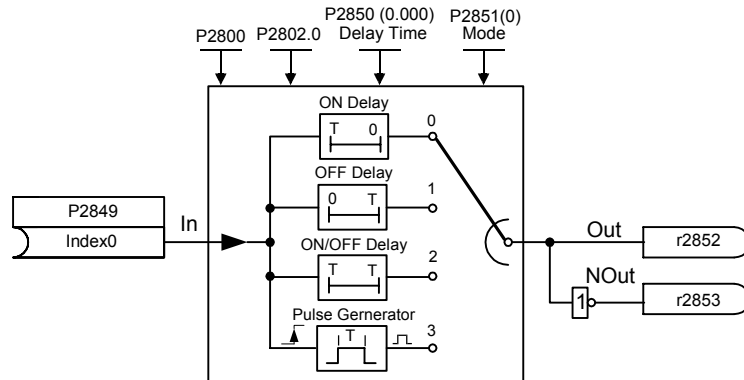

Dependency:
P2802[0] is active level for the timer.

P2850	Delay time of timer 1	Datatype: Float	Unit: s	Min: 0.0	Level 3
	CStat: CUT	Active: first confirm	QuickComm.: No	Def: 0.0	
	P-Group: TECH			Max: 6000.0	

Defines delay time of timer 1. P2849, P2850, P2851 are the inputs of the timer, outputs are P2852, P2853.

Dependency:
P2802[0] is active level for the timer.

P2851	Mode timer 1 CStat: CUT P-Group: TECH	Datatype: U16 Active: first confirm	Unit: - QuickComm.: No	Min: 0 Def: 0 Max: 3	Level 3
Selects mode of timer 1. P2849, P2850, P2851 are the inputs of the timer, outputs are P2852, P2853.					
Possible Settings:					
0 ON delay					
1 OFF delay					
2 ON/OFF delay					
3 Pulse generator					
Dependency: P2802[0] is active level for the timer.					
r2852	BO: Timer 1 P-Group: TECH	Datatype: U16	Unit: -	Min: - Def: - Max: -	Level 3
Displays output of timer 1. P2849, P2850, P2851 are the inputs of the timer, outputs are P2852, P2853.					
Dependency: P2802[0] is active level for the timer.					
r2853	BO: Nout timer 1 P-Group: TECH	Datatype: U16	Unit: -	Min: - Def: - Max: -	Level 3
Displays Not-output of timer 1. P2849, P2850, P2851 are the inputs of the timer, outputs are P2852, P2853.					
Dependency: P2802[0] is active level for the timer.					
P2854	BI: Timer 2 CStat: CUT P-Group: TECH	Datatype: U32 Active: first confirm	Unit: - QuickComm.: No	Min: 0:0 Def: 0:0 Max: 4000:0	Level 3
Define input signal of timer 2. P2854, P2855, P2856 are the inputs of the timer, outputs are P2857, P2858.					
Dependency: P2802[1] is active level for the timer.					
P2855	Delay time of timer 2 CStat: CUT P-Group: TECH	Datatype: Float Active: first confirm	Unit: s QuickComm.: No	Min: 0.0 Def: 0.0 Max: 6000.0	Level 3
Defines delay time of timer 2. P2854, P2855, P2856 are the inputs of the timer, outputs are P2857, P2858.					
Dependency: P2802[1] is active level for the timer.					
P2856	Mode timer 2 CStat: CUT P-Group: TECH	Datatype: U16 Active: first confirm	Unit: - QuickComm.: No	Min: 0 Def: 0 Max: 3	Level 3
Selects mode of timer 2. P2854, P2855, P2856 are the inputs of the timer, outputs are P2857, P2858.					
Possible Settings:					
0 ON delay					
1 OFF delay					
2 ON/OFF delay					
3 Pulse generator					
Dependency: P2802[1] is active level for the timer.					
r2857	BO: Timer 2 P-Group: TECH	Datatype: U16	Unit: -	Min: - Def: - Max: -	Level 3
Displays output of timer 2. P2854, P2855, P2856 are the inputs of the timer, outputs are P2857, P2858.					
Dependency: P2802[1] is active level for the timer.					
r2858	BO: Nout timer 2 P-Group: TECH	Datatype: U16	Unit: -	Min: - Def: - Max: -	Level 3
Displays Not-output of timer 2 P2854, P2855, P2856 are the inputs of the timer, outputs are P2857, P2858.					
Dependency: P2802[1] is active level for the timer.					

P2859	BI: Timer 3			Min: 0:0	Level 3
	CStat: CUT	Datatype: U32	Unit: -	Def: 0:0	
	P-Group: TECH	Active: first confirm	QuickComm.: No	Max: 4000:0	

Define input signal of timer 3. P2859, P2860, P2861 are the inputs of the timer, outputs are P2862, P2863.

Dependency:

P2802[2] is active level for the timer.

P2860	Delay time of timer 3			Min: 0.0	Level 3
	CStat: CUT	Datatype: Float	Unit: s	Def: 0.0	
	P-Group: TECH	Active: first confirm	QuickComm.: No	Max: 6000.0	

Defines delay time of timer 3. P2859, P2860, P2861 are the inputs of the timer, outputs are P2862, P2863.

Dependency:

P2802[2] is active level for the timer.

P2861	Mode timer 3			Min: 0	Level 3
	CStat: CUT	Datatype: U16	Unit: -	Def: 0	
	P-Group: TECH	Active: first confirm	QuickComm.: No	Max: 3	

Selects mode of timer 3. P2859, P2860, P2861 are the inputs of the timer, outputs are P2862, P2863.

Possible Settings:

- 0 ON delay
- 1 OFF delay
- 2 ON/OFF delay
- 3 Pulse generator

Dependency:

P2802[2] is active level for the timer.

r2862	BO: Timer 3			Min: -	Level 3
	P-Group: TECH	Datatype: U16	Unit: -	Def: -	
				Max: -	

Displays output of timer 3. P2859, P2860, P2861 are the inputs of the timer, outputs are P2862, P2863.

Dependency:

P2802[2] is active level for the timer.

r2863	BO: Nout timer 3			Min: -	Level 3
	P-Group: TECH	Datatype: U16	Unit: -	Def: -	
				Max: -	

Displays Not-output of timer 3. P2859, P2860, P2861 are the inputs of the timer, outputs are P2862, P2863.

Dependency:

P2802[2] is active level for the timer.

P2864	BI: Timer 4			Min: 0:0	Level 3
	CStat: CUT	Datatype: U32	Unit: -	Def: 0:0	
	P-Group: TECH	Active: first confirm	QuickComm.: No	Max: 4000:0	

Define input signal of timer 4. P2864, P2865, P2866 are the inputs of the timer, outputs are P2867, P2868.

Dependency:

P2802[3] is active level for the timer.

P2865	Delay time of timer 4			Min: 0.0	Level 3
	CStat: CUT	Datatype: Float	Unit: s	Def: 0.0	
	P-Group: TECH	Active: first confirm	QuickComm.: No	Max: 6000.0	

Defines delay time of timer 4. P2864, P2865, P2866 are the inputs of the timer, outputs are P2867, P2868.

Dependency:

P2802[3] is active level for the timer.

P2866	Mode timer 4			Min: 0	Level 3
	CStat: CUT	Datatype: U16	Unit: -	Def: 0	
	P-Group: TECH	Active: first confirm	QuickComm.: No	Max: 3	

Selects mode of timer 4. P2864, P2865, P2866 are the inputs of the timer, outputs are P2867, P2868.

Possible Settings:

- 0 ON delay
- 1 OFF delay
- 2 ON/OFF delay
- 3 Pulse generator

Dependency:

P2802[3] is active level for the timer.

r2867	BO: Timer 4	Datatype: U16	Unit: -	Min: - Def: - Max: -	Level 3
	P-Group: TECH				

Displays output of timer 4. P2864, P2865, P2866 are the inputs of the timer, outputs are P2867, P2868.

Dependency:
P2802[3] is active level for the timer.

r2868	BO: Nout timer 4	Datatype: U16	Unit: -	Min: - Def: - Max: -	Level 3
	P-Group: TECH				

Displays Not-output of timer 4. P2864, P2865, P2866 are the inputs of the timer, outputs are P2867, P2868.

Dependency:
P2802[3] is active level for the timer.

P2869[2]	CI: ADD 1	Datatype: U32	Unit: -	Min: 0:0 Def: 755:0 Max: 4000:0	Level 3
	CStat: CUT	Active: first confirm	QuickComm.: No		
	P-Group: TECH				

Define inputs of Adder 1, result is in P2870.

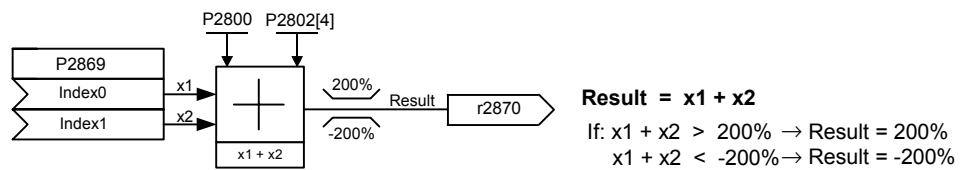

Index:
P2869[0] : Connector input 0 (CI 0)
P2869[1] : Connector input 1 (CI 1)

Dependency:
P2802[4] is the active level for the Adder.

r2870	CO: ADD 1	Datatype: Float	Unit: %	Min: - Def: - Max: -	Level 3
	P-Group: TECH				

Result of Adder 1.

Dependency:
P2802[4] is active level for the Adder.

P2871[2]	CI: ADD 2	Datatype: U32	Unit: -	Min: 0:0 Def: 755:0 Max: 4000:0	Level 3
	CStat: CUT	Active: first confirm	QuickComm.: No		
	P-Group: TECH				

Define inputs of Adder 2, result is in P2872.

Index:
P2871[0] : Connector input 0 (CI 0)
P2871[1] : Connector input 1 (CI 1)

Dependency:
P2802[5] is active level for the Adder.

r2872	CO: ADD 2	Datatype: Float	Unit: %	Min: - Def: - Max: -	Level 3
	P-Group: TECH				

Result of Adder 2.

Dependency:
P2802[5] is active level for the Adder.

P2873[2]	CI: SUB 1	Datatype: U32	Unit: -	Min: 0:0	Level 3
	CStat: CUT	Active: first confirm	QuickComm.: No	Def: 755:0	
	P-Group: TECH			Max: 4000:0	

Define inputs of Subtractor 1, result is in P2874.

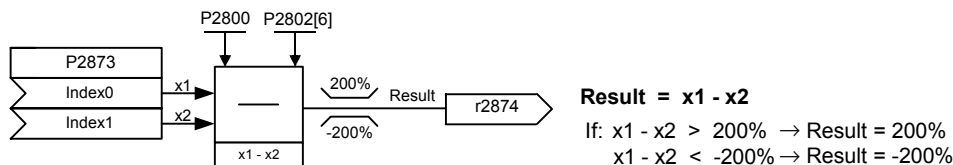

Index:

P2873[0] : Connector input 0 (CI 0)
P2873[1] : Connector input 1 (CI 1)

Dependency:

P2802[6] is active level for the Subtractor.

r2874	CO: SUB 1	Datatype: Float	Unit: %	Min: -	Level 3
	P-Group: TECH			Def: -	
				Max: -	

Result of Subtractor 1.

Dependency:

P2802[6] is active level for the Subtractor.

P2875[2]	CI: SUB 2	Datatype: U32	Unit: -	Min: 0:0	Level 3
	CStat: CUT	Active: first confirm	QuickComm.: No	Def: 755:0	
	P-Group: TECH			Max: 4000:0	

Define inputs of Subtractor 2, result is in P2876.

Index:

P2875[0] : Connector input 0 (CI 0)
P2875[1] : Connector input 1 (CI 1)

Dependency:

P2802[7] is active level for the Subtractor.

r2876	CO: SUB 2	Datatype: Float	Unit: %	Min: -	Level 3
	P-Group: TECH			Def: -	
				Max: -	

Result of Subtractor 2.

Dependency:

P2802[7] is active level for the Subtractor.

P2877[2]	CI: MUL 1	Datatype: U32	Unit: -	Min: 0:0	Level 3
	CStat: CUT	Active: first confirm	QuickComm.: No	Def: 755:0	
	P-Group: TECH			Max: 4000:0	

Define inputs of Multiplier 1, result is in P2878.

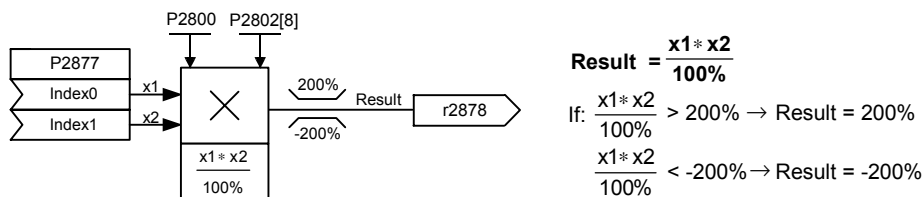

Index:

P2877[0] : Connector input 0 (CI 0)
P2877[1] : Connector input 1 (CI 1)

Dependency:

P2802[8] is active level for the Multiplier.

r2878	CO: MUL 1	Datatype: Float	Unit: %	Min: -	Level 3
	P-Group: TECH			Def: -	
				Max: -	

Result of Multiplier 1.

Dependency:

P2802[8] is active level for the Multiplier.

P2879[2]	CI: MUL 2	Datatype: U32	Unit: -	Min: 0:0	Level 3
	CStat: CUT	Active: first confirm	QuickComm.: No	Def: 755:0	
	P-Group: TECH			Max: 4000:0	

Define inputs of Multiplier 2, result is in P2880.

Index:

P2879[0] : Connector input 0 (CI 0)
P2879[1] : Connector input 1 (CI 1)

Dependency:

P2802[9] is active level for the Multiplier.

r2880	CO: MUL 2	Datatype: Float	Unit: %	Min: -	Level 3
	P-Group: TECH			Def: -	
				Max: -	

Result of Multiplier 2.

Dependency:

P2802[9] is active level for the Multiplier.

P2881[2]	CI: DIV 1	Datatype: U32	Unit: -	Min: 0:0	Level 3
	CStat: CUT	Active: first confirm	QuickComm.: No	Def: 755:0	
	P-Group: TECH			Max: 4000:0	

Define inputs of Divider 1, result is in P2882.

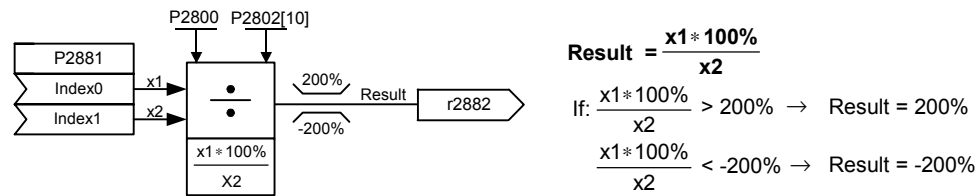

Index:

P2881[0] : Connector input 0 (CI 0)
P2881[1] : Connector input 1 (CI 1)

Dependency:

P2802[10] is active level for the Divider.

r2882	CO: DIV 1	Datatype: Float	Unit: %	Min: -	Level 3
	P-Group: TECH			Def: -	
				Max: -	

Result of Divider 1.

Dependency:

P2802[10] is active level for the Divider.

P2883[2]	CI: DIV 2	Datatype: U32	Unit: -	Min: 0:0	Level 3
	CStat: CUT	Active: first confirm	QuickComm.: No	Def: 755:0	
	P-Group: TECH			Max: 4000:0	

Define inputs of Divider 2, result is in P2884.

Index:

P2883[0] : Connector input 0 (CI 0)
P2883[1] : Connector input 1 (CI 1)

Dependency:

P2802[11] is active level for the Divider.

r2884	CO: DIV 2	Datatype: Float	Unit: %	Min: -	Level 3
	P-Group: TECH			Def: -	
				Max: -	

Result of Divider 2.

Dependency:

P2802[11] is active level for the Divider.

P2885[2]	CI: CMP 1	Datatype: U32	Unit: -	Min: 0:0	Level 3
	CStat: CUT	Active: first confirm	QuickComm.: No	Def: 755:0	
	P-Group: TECH			Max: 4000:0	

Defines inputs of Comparator 1, output is P2886.

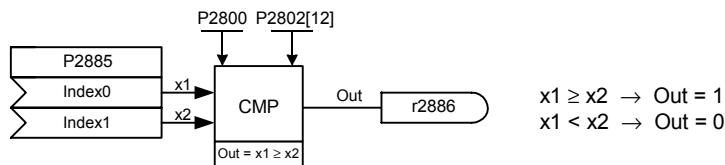

Index:

P2885[0] : Connector input 0 (CI 0)
 P2885[1] : Connector input 1 (CI 1)

Dependency:

P2802[12] is active level for the Comparator.

r2886	BO: CMP 1	Datatype: U16	Unit: -	Min: -	Level 3
	P-Group: TECH			Def: -	
				Max: -	

Displays result bit of Comparator 1.

Dependency:

P2802[12] is active level for the Comparator.

P2887[2]	CI: CMP 2	Datatype: U32	Unit: -	Min: 0:0	Level 3
	CStat: CUT	Active: first confirm	QuickComm.: No	Def: 755:0	
	P-Group: TECH			Max: 4000:0	

Defines inputs of Comparator 2, output is P2888.

Index:

P2887[0] : Connector input 0 (CI 0)
 P2887[1] : Connector input 1 (CI 1)

Dependency:

P2802[13] is active level for the Comparator.

r2888	BO: CMP 2	Datatype: U16	Unit: -	Min: -	Level 3
	P-Group: TECH			Def: -	
				Max: -	

Displays result bit of Comparator 2.

Dependency:

P2802[13] is active level for the Comparator.

P2889	CO: Fixed setpoint 1 in [%]	Datatype: Float	Unit: %	Min: -200.00	Level 3
	CStat: CUT	Active: first confirm	QuickComm.: No	Def: 0.00	
	P-Group: TECH			Max: 200.00	

Fixed percent setting 1.

Connector Setting in %

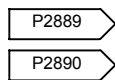

Range : -200% ... 200%

P2890	CO: Fixed setpoint 2 in [%]	Datatype: Float	Unit: %	Min: -200.00	Level 3
	CStat: CUT	Active: first confirm	QuickComm.: No	Def: 0.00	
	P-Group: TECH			Max: 200.00	

Fixed percent setting 2.

3.39 Inverter parameters

P3900	End of quick commissioning	Min: 0	Level 1		
	CStat: C	Datatype: U16		Unit: -	Def: 0
	P-Group: QUICK	Active: first confirm		QuickComm.: Yes	Max: 3

Performs calculations necessary for optimized motor operation.

After completion of calculation, P3900 and P0010 (parameter groups for commissioning) are automatically reset to their original value 0.

Possible Settings:

- 0 No quick commissioning
- 1 Start quick commissioning with factory reset
- 2 Start quick commissioning
- 3 Start quick commissioning only for motor data

Dependency:

Changeable only when P0010 = 1 (quick commissioning)

Note:

P3900 = 1 :

When setting 1 is selected, only the parameter settings carried out via the commissioning menu "Quick commissioning", are retained; all other parameter changes, including the I/O settings, are lost. Motor calculations are also performed.

P3900 = 2 :

When setting 2 is selected, only those parameters, which depend on the parameters in the commissioning menu "Quick commissioning" (P0010 = 1) are calculated. The I/O settings are also reset to default and the motor calculations performed.

P3900 = 3 :

When setting 3 is selected, only the motor and controller calculations are performed. Exiting quick commissioning with this setting saves time (for example, if only motor rating plate data have been changed).

Calculates a variety of motor parameters, overwriting previous values (see parameter P0340, setting P0340 = 1).

4 Function Diagrams

Explanation of symbols used in the function diagrams

Setting parameters

ParName
 Min ... Max [Dim]
 PNumber.C/D [3] (Default)
 Parameter text
 Minimum ... Maximum value [Unit]
 Parameter number.Command/Drive data set [Number indexes] (Default)

Monitoring parameters

ParName [Dim]
 PNumber.C/D [3]
 Parameter text [Unit]
 Parameter number.Command/Drive data set [Number indexes]

BICO parameters

Binector input (Setting parameter)

ParName [Dim]
 PNum.C/D [3] (Default)
 Parameter text [Unit]
 Parameter number.Command/Drive data set (Default)

Binector output (Monitoring parameter)

ParName [FNum]
 Parameter text
 Parameter number

Connector input (Setting parameter)

ParName [PNum.C/D [3] (Default)]
 Parameter text
 Parameter number.Command/Drive data set [Number indexes] (Default)

Connector output (Monitoring parameter)

ParName [Hz] [FNum [3]]
 Parameter text [Unit]
 Parameter number [Number indexes]

Connector/Binector output (Monitoring parameter)

ParName [FNum]
 Parameter text
 Parameter number

1	2	3	4	5	6	7	8
Symbols in function diagrams							
						Function diagram	
						0010_Symbols.vsd	
						14.03.2005	V2.0
						MICROMASTER 430	- 10 -

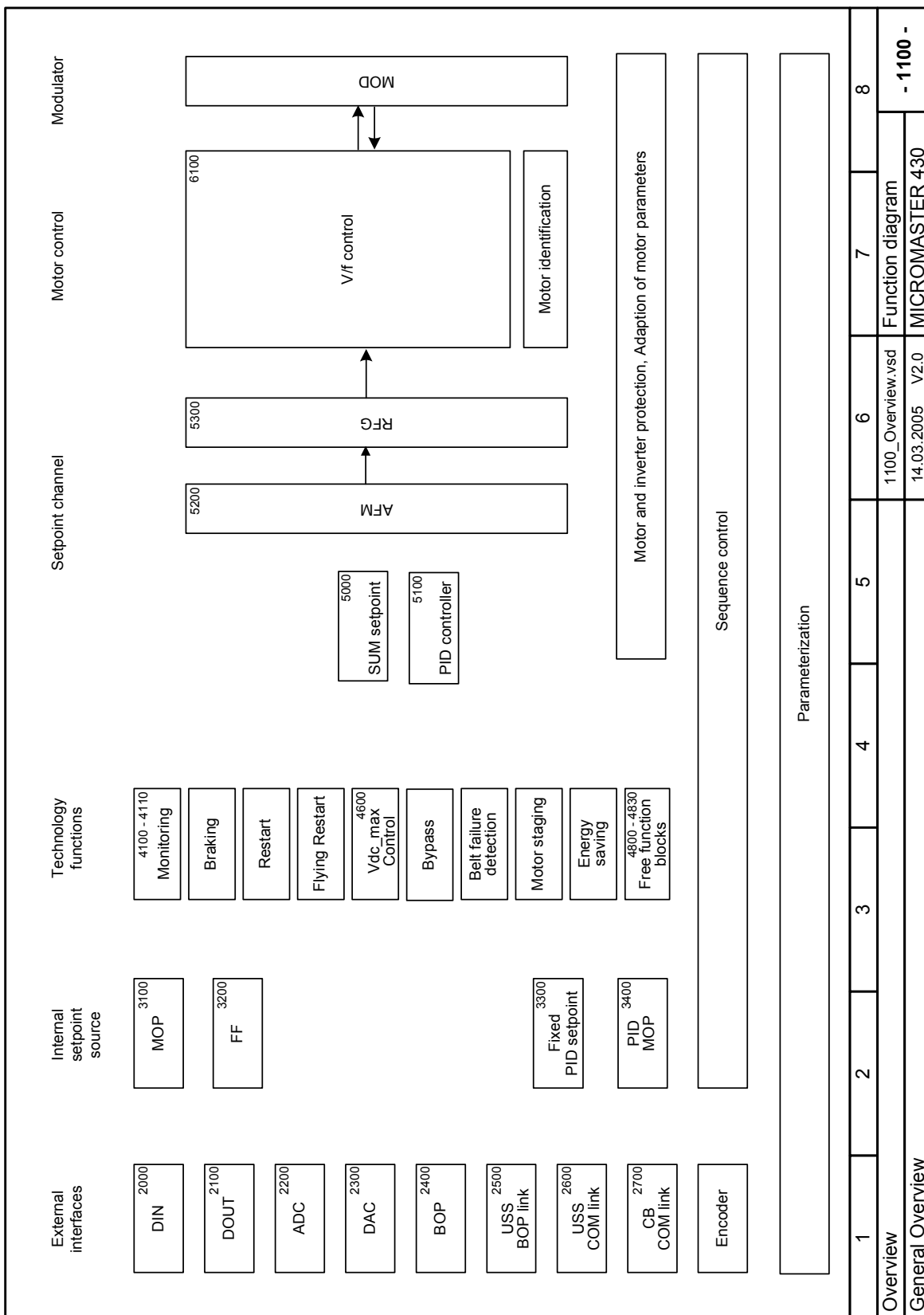

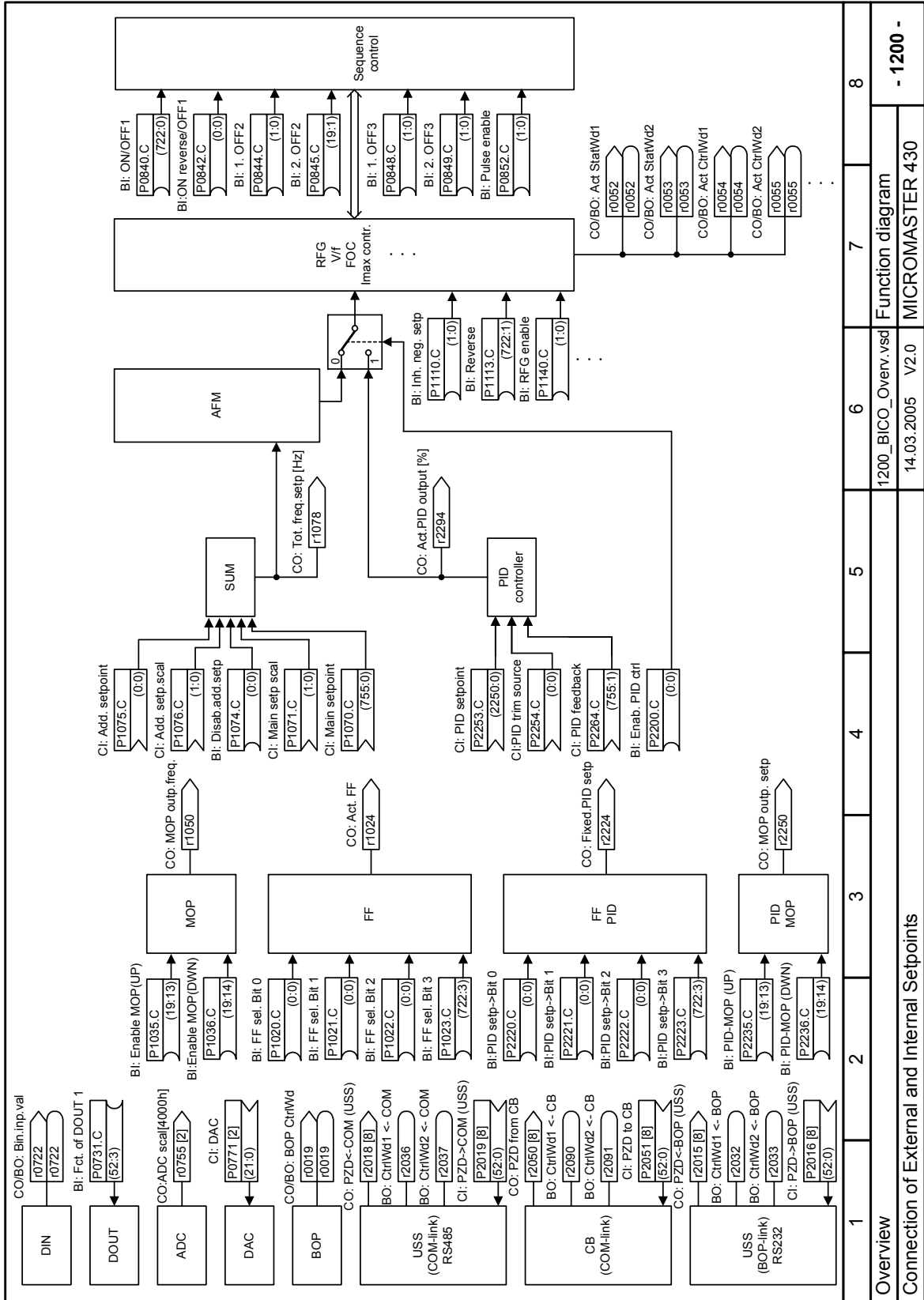

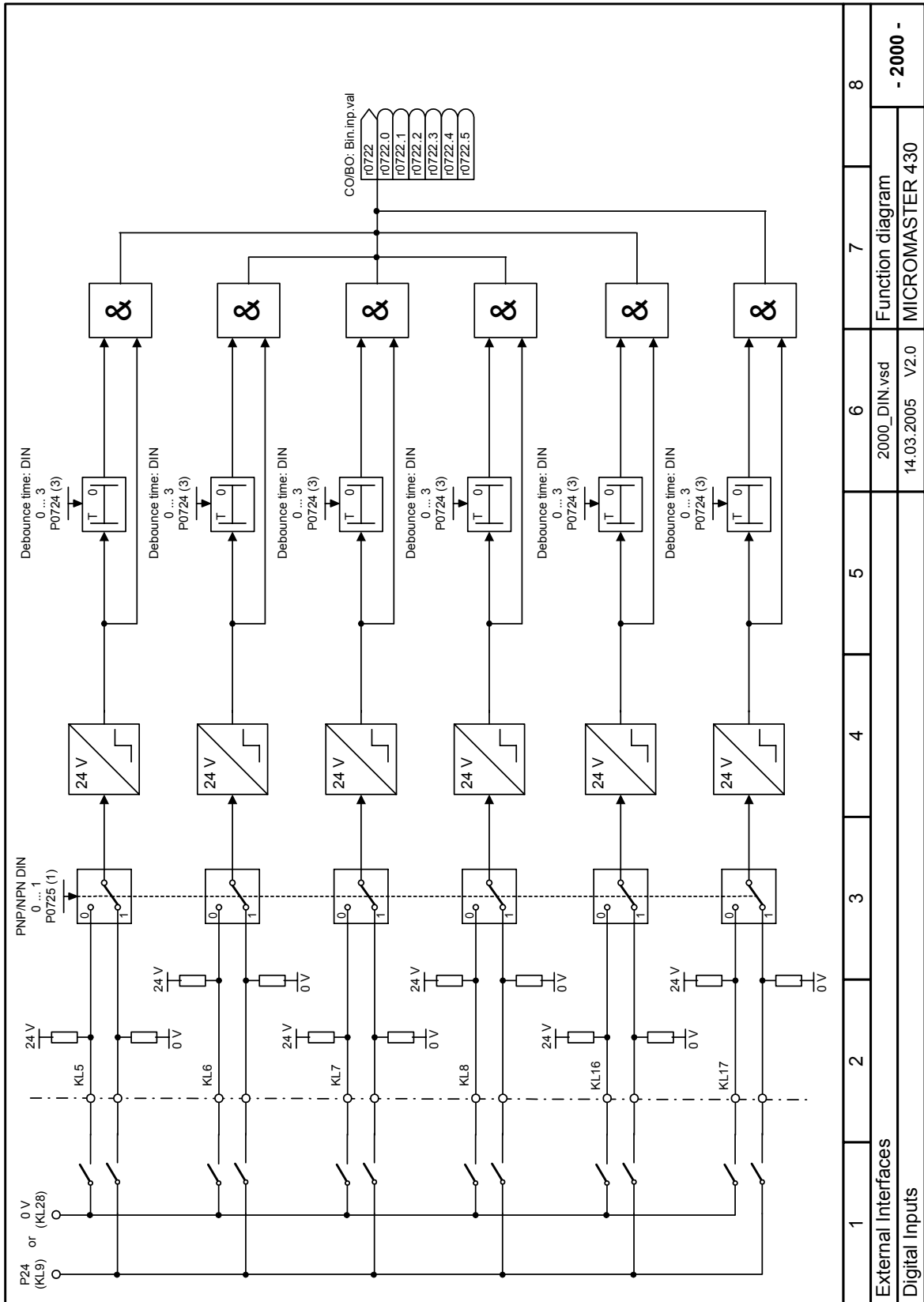

1	2	3	4	5	6	7	8
External Interfaces				2000_DIN.vsd		Function diagram	
Digital Inputs				14.03.2005 V2.0		MICROMASTER 430	
						- 2000 -	

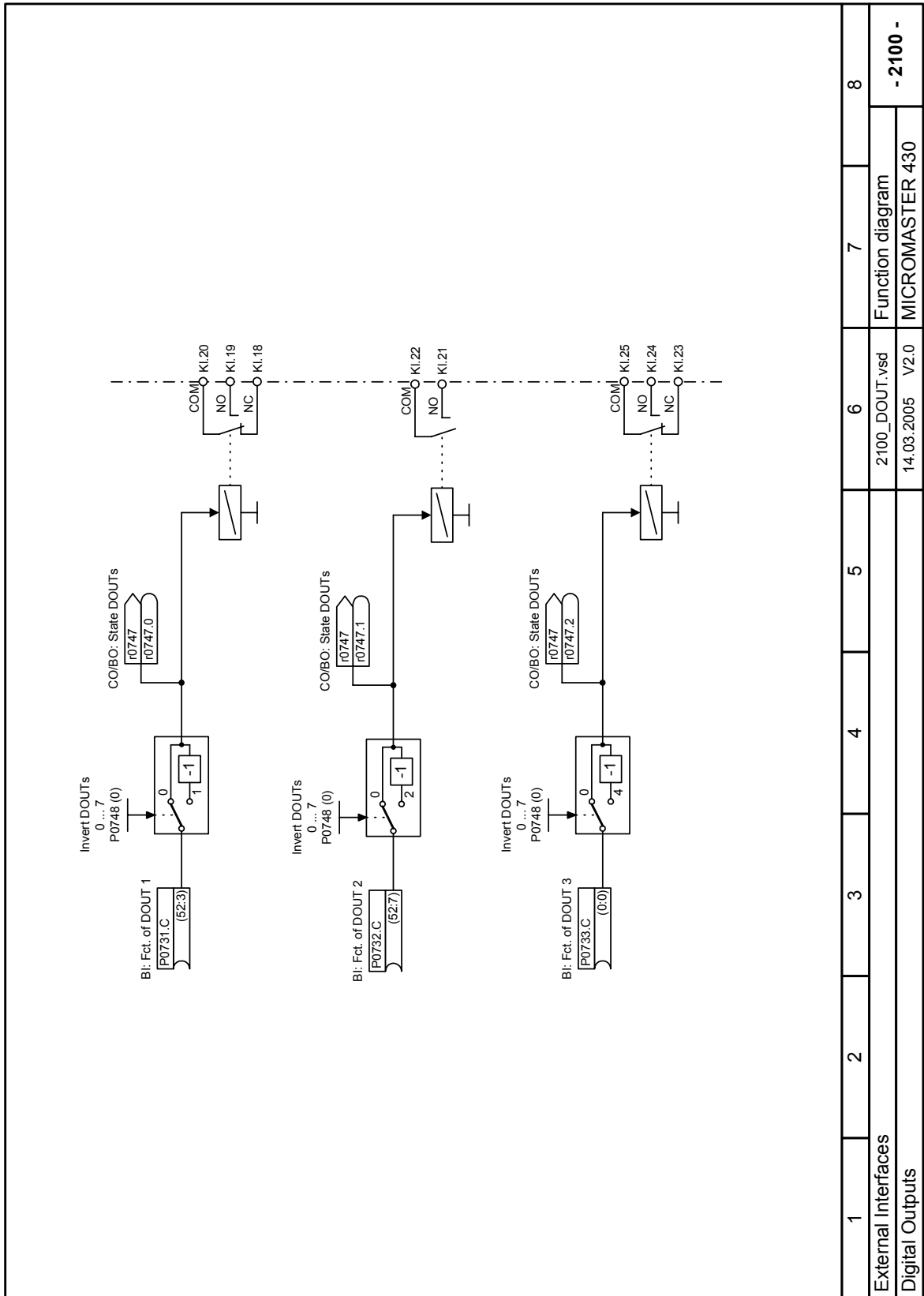

1	2	3	4	5	6	7	8
External Interfaces							
Digital Outputs							
					2100_DOUT.vsd	Function diagram	
					14.03.2005	MICROMASTER 430	
					V2.0	- 2100 -	

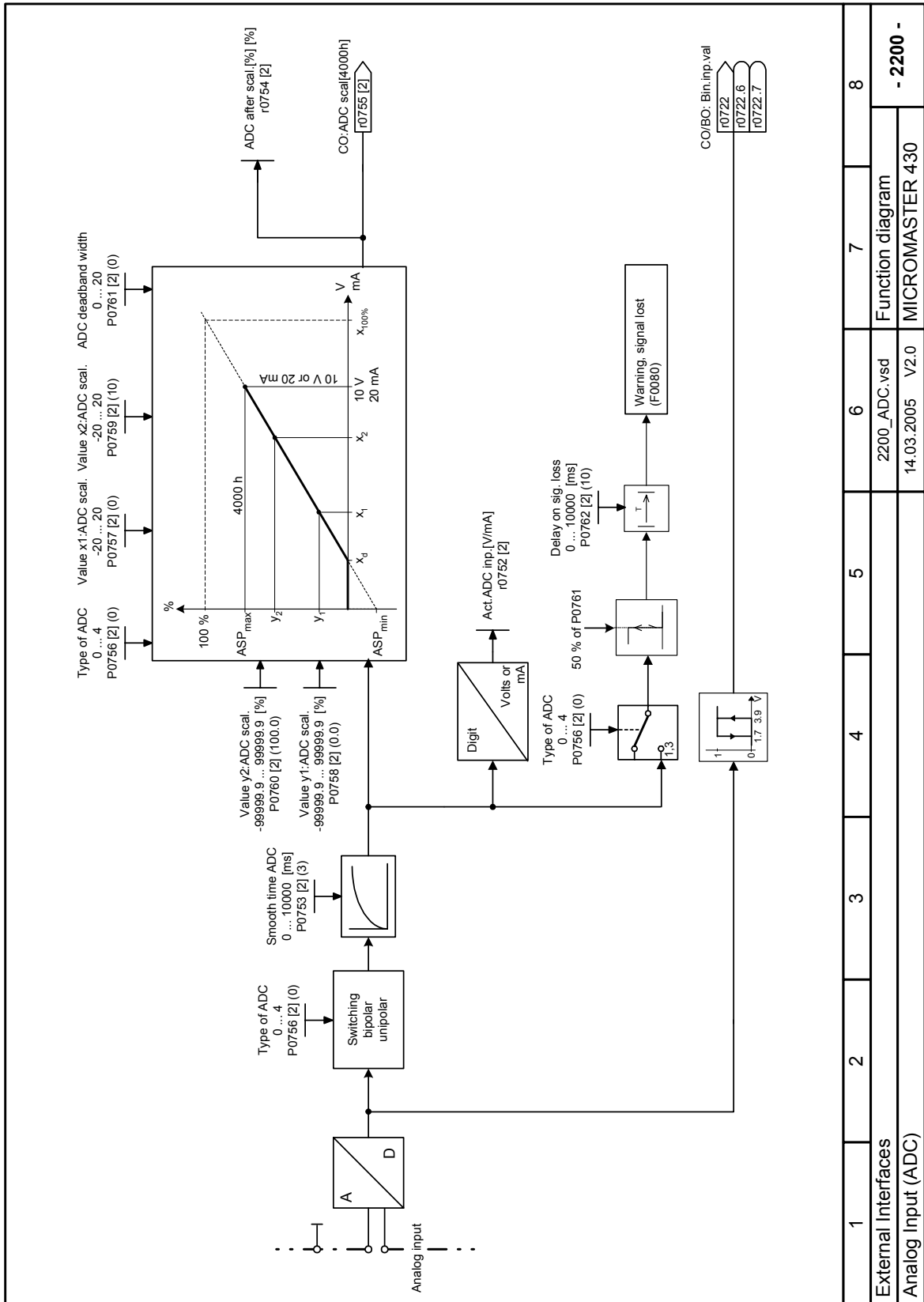

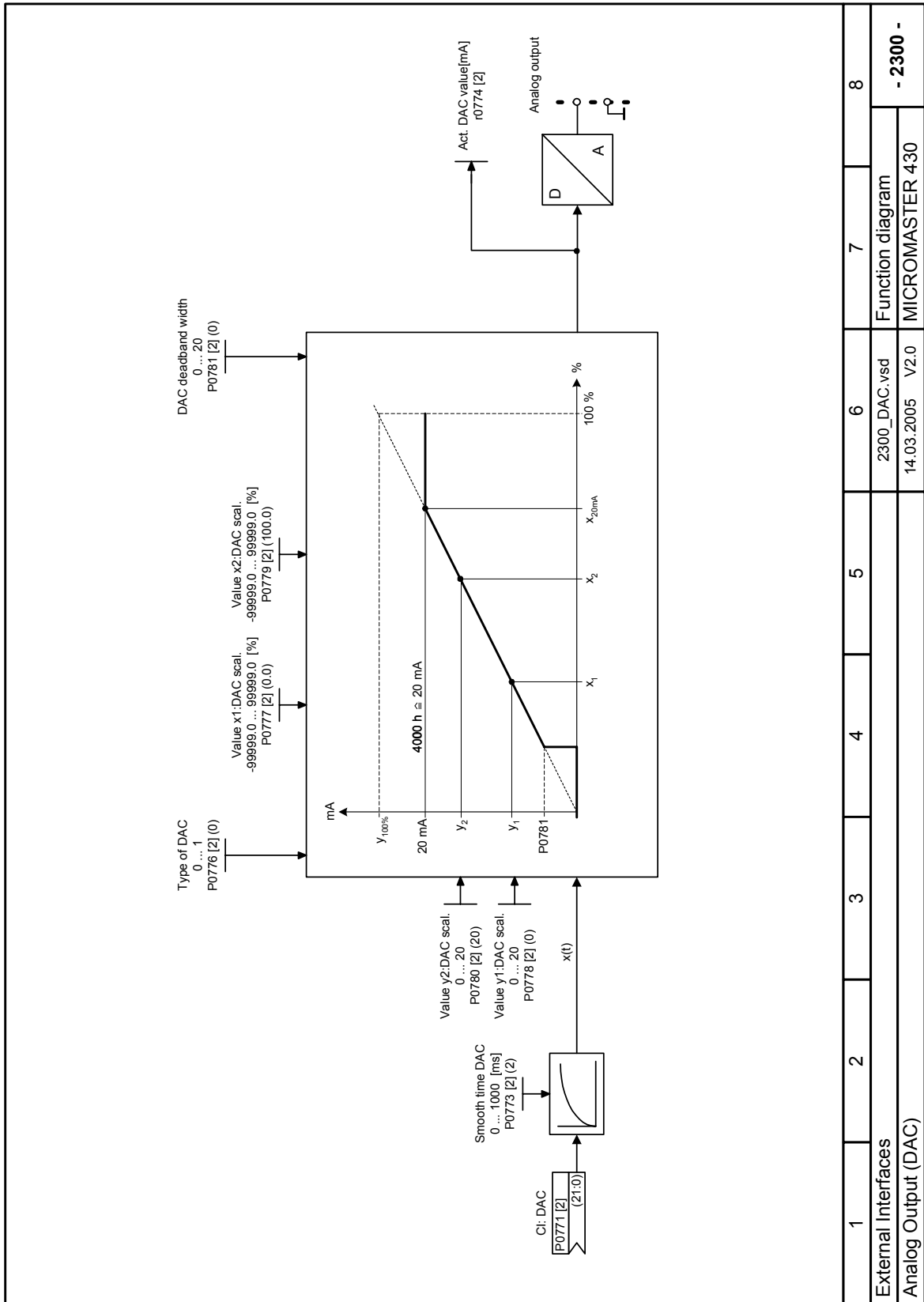

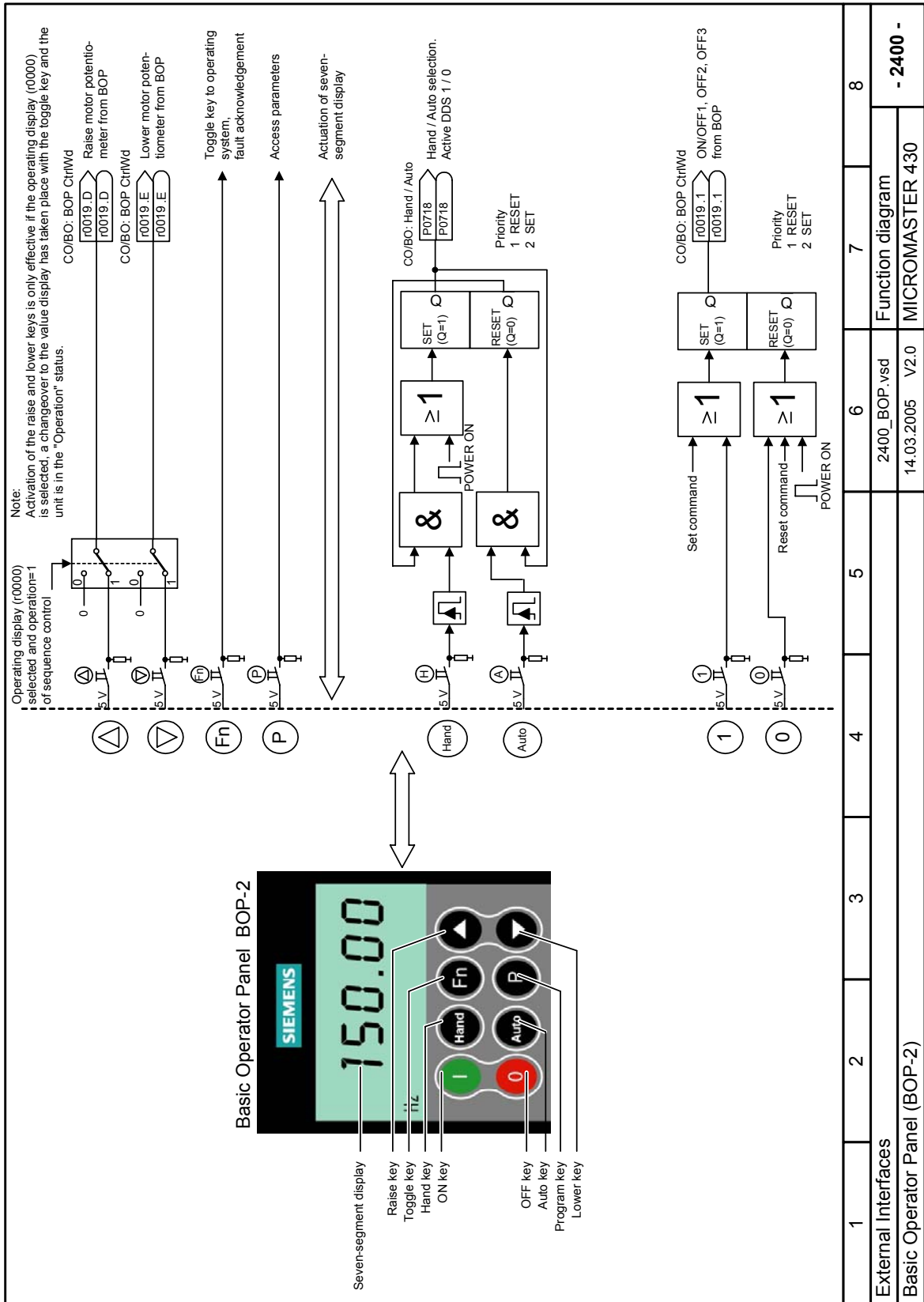

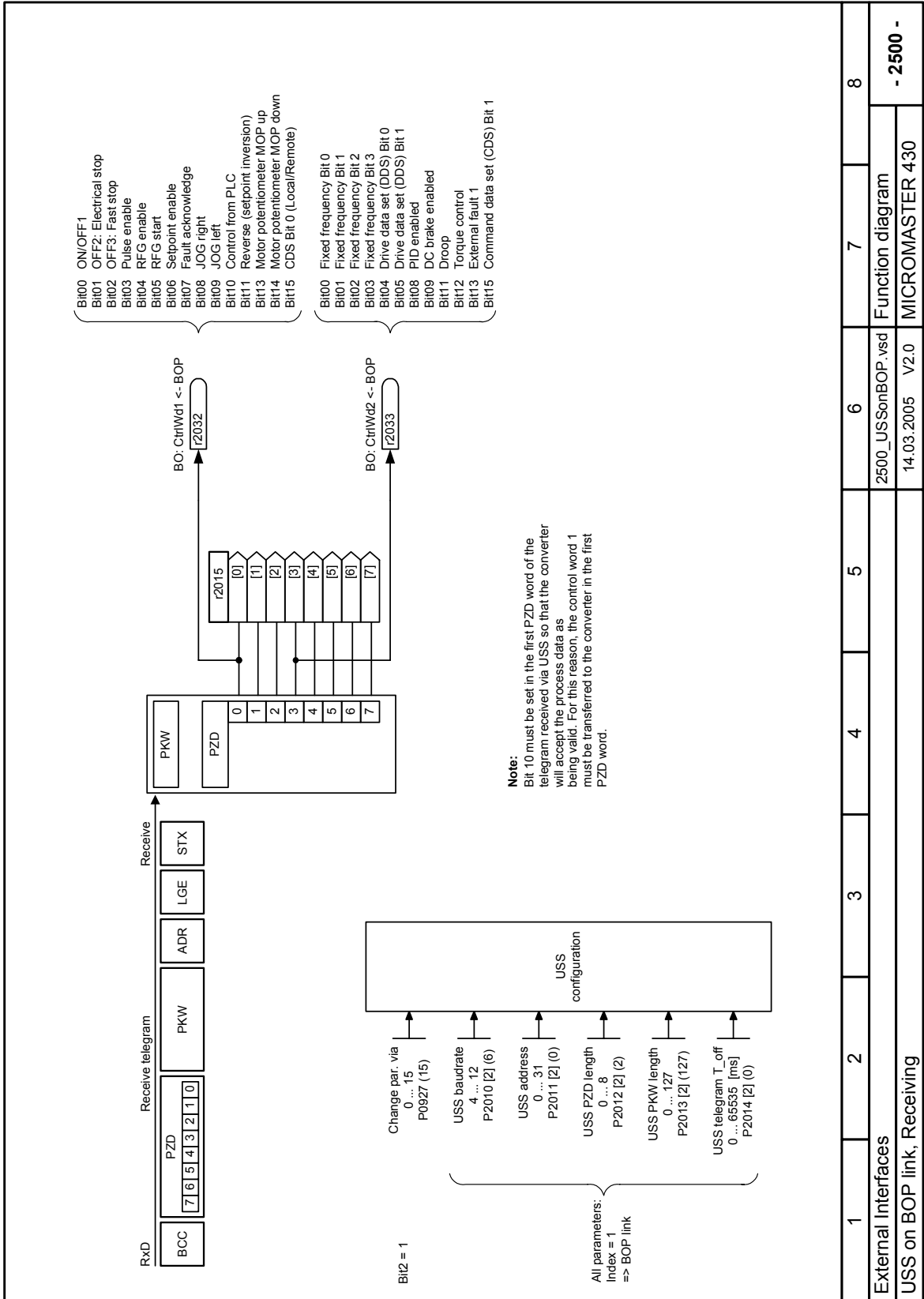

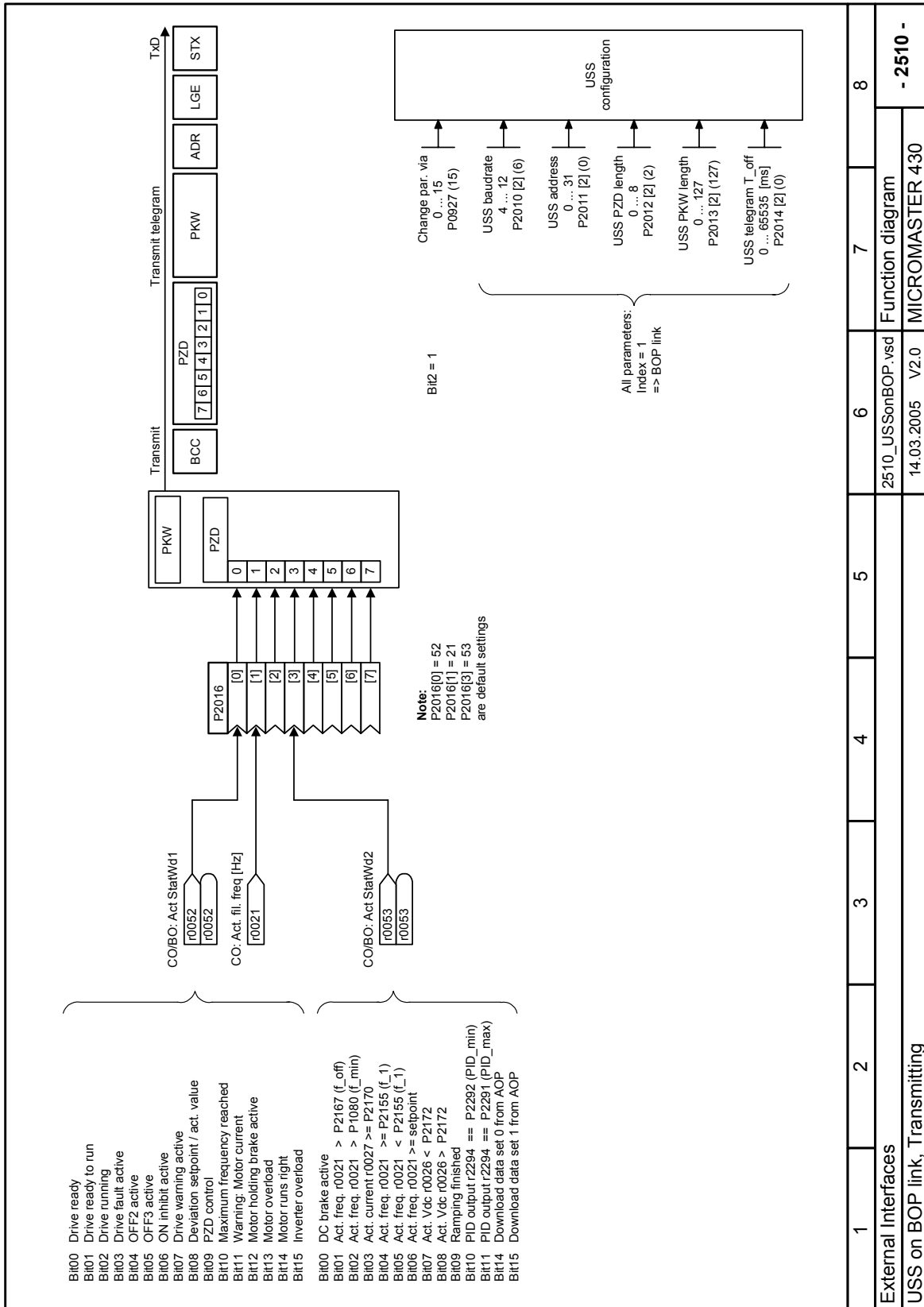

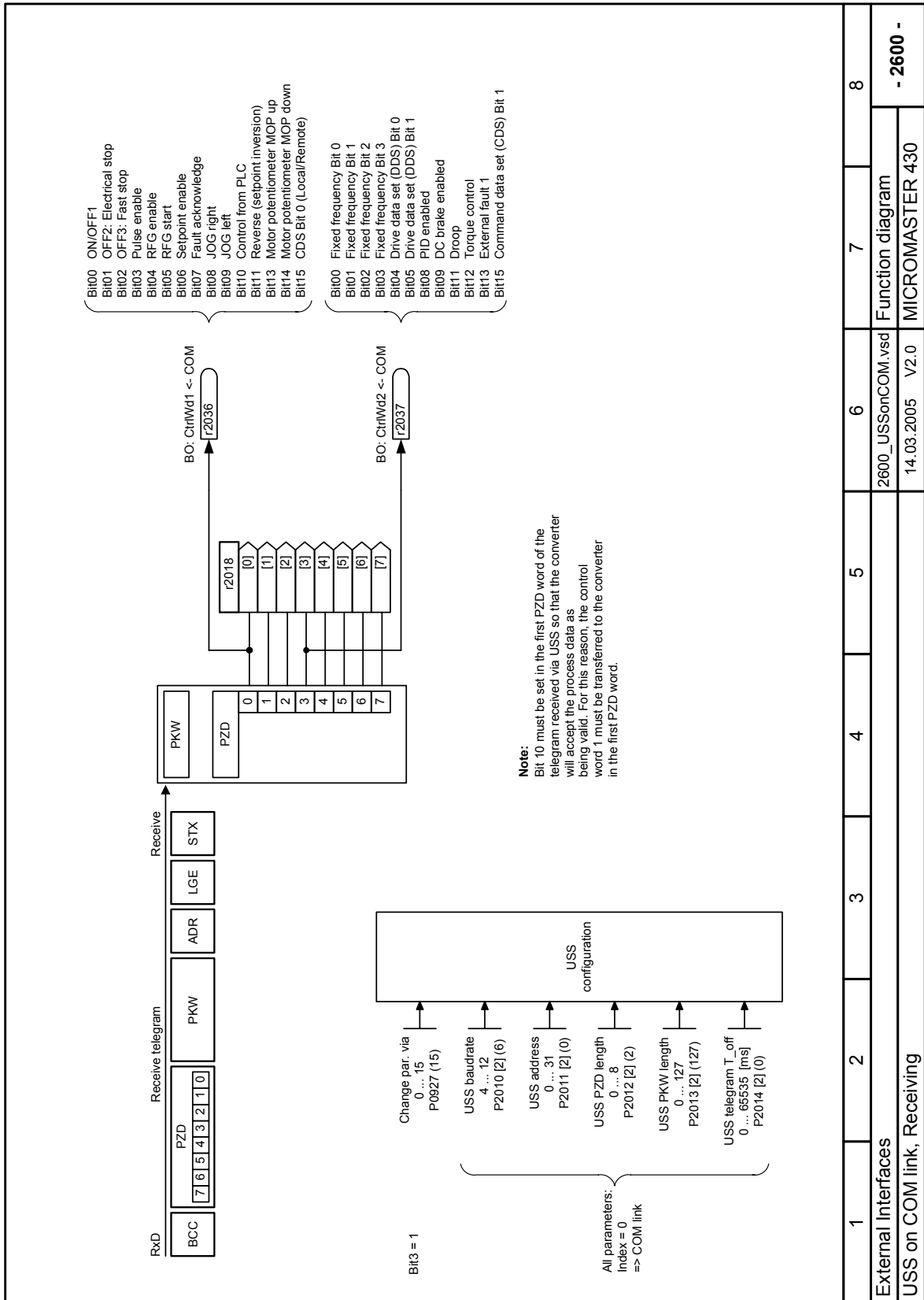

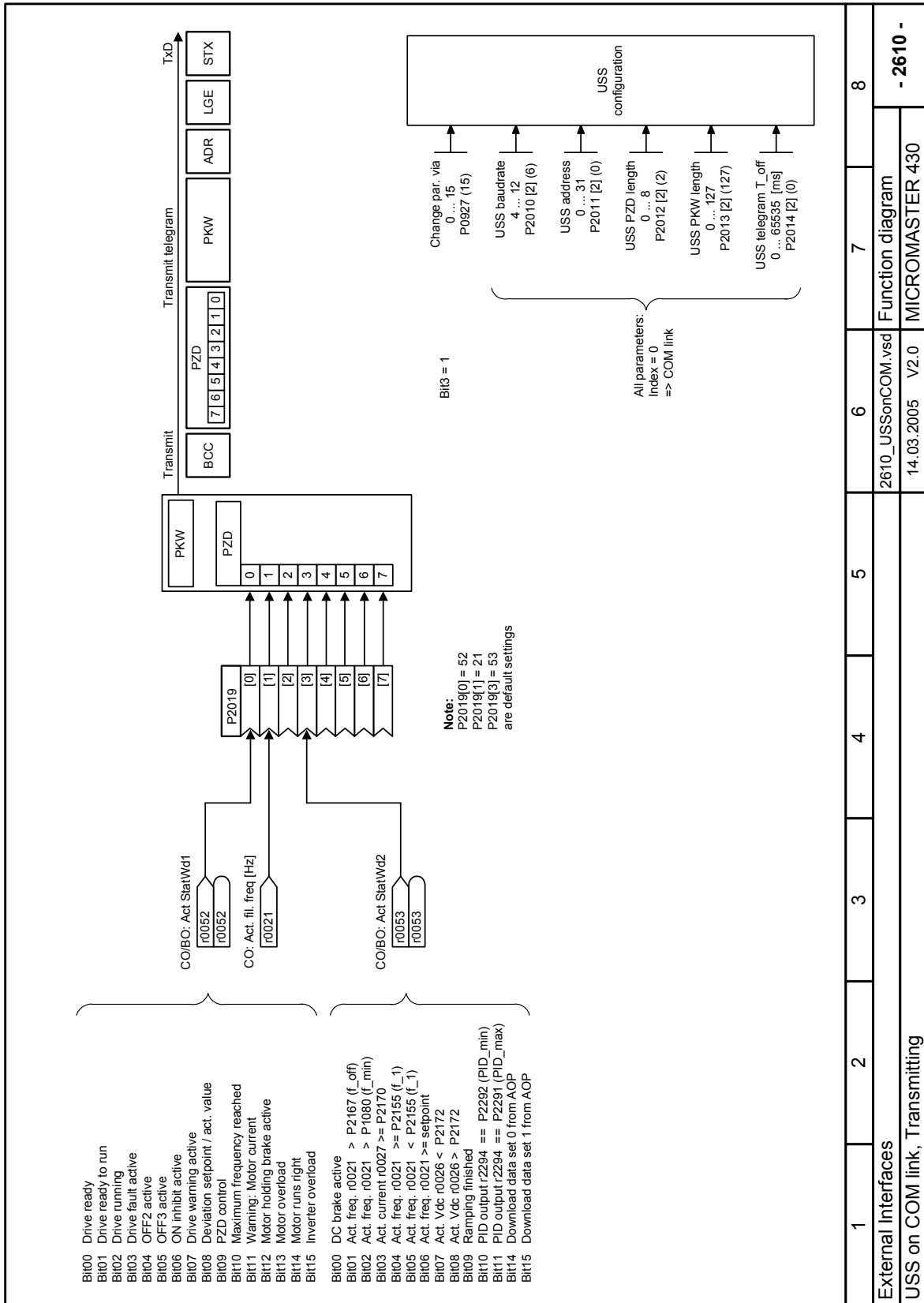

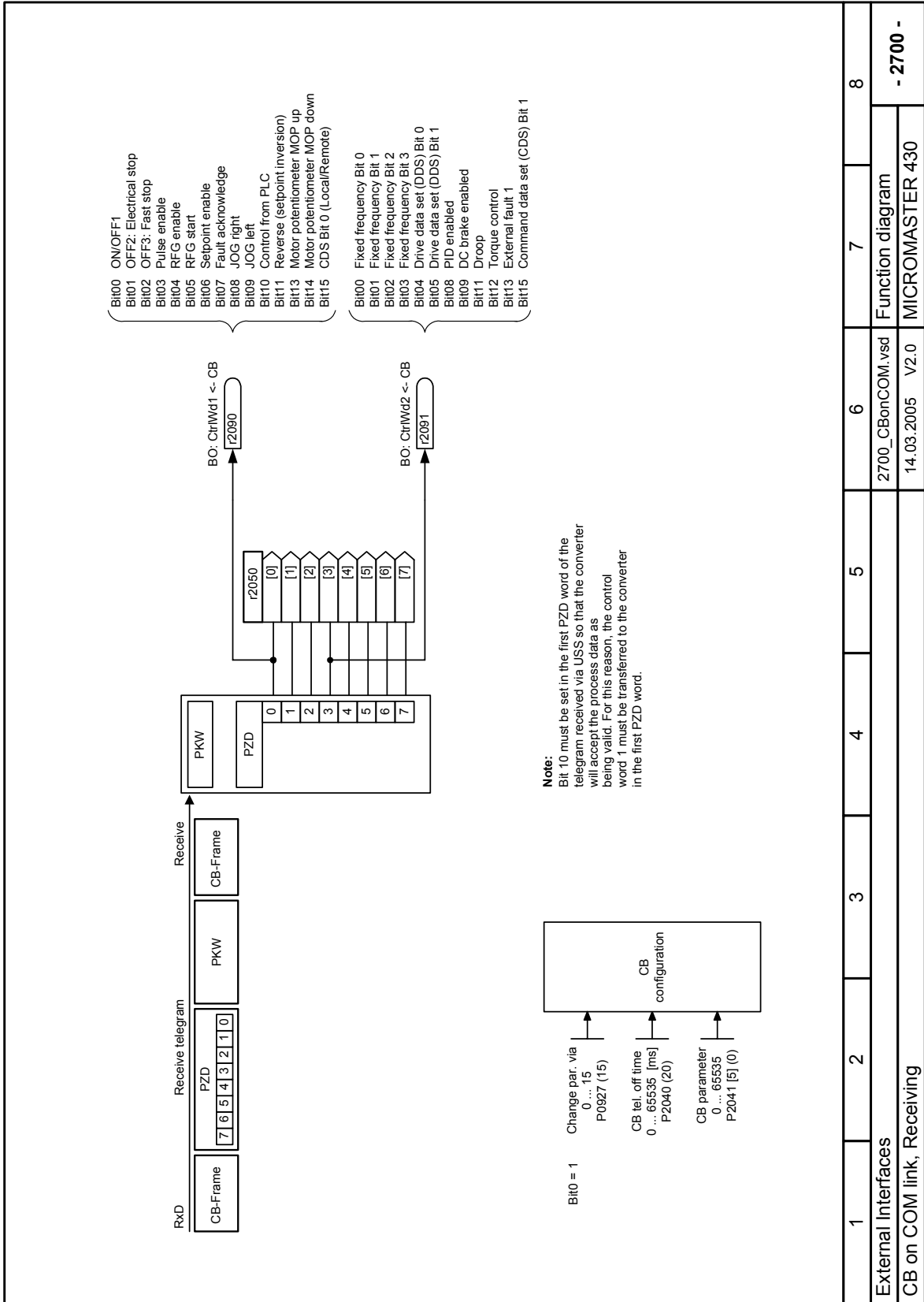

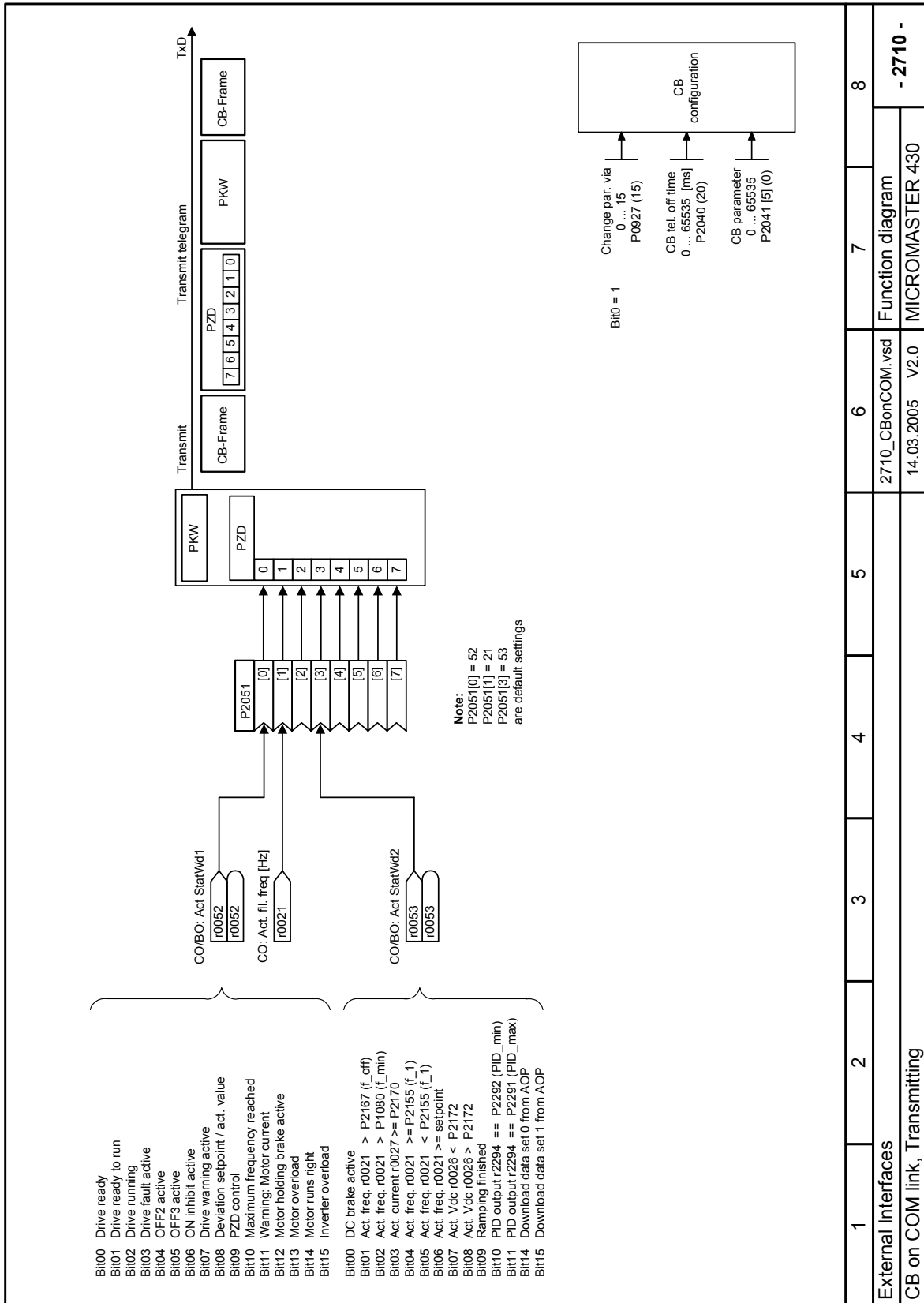

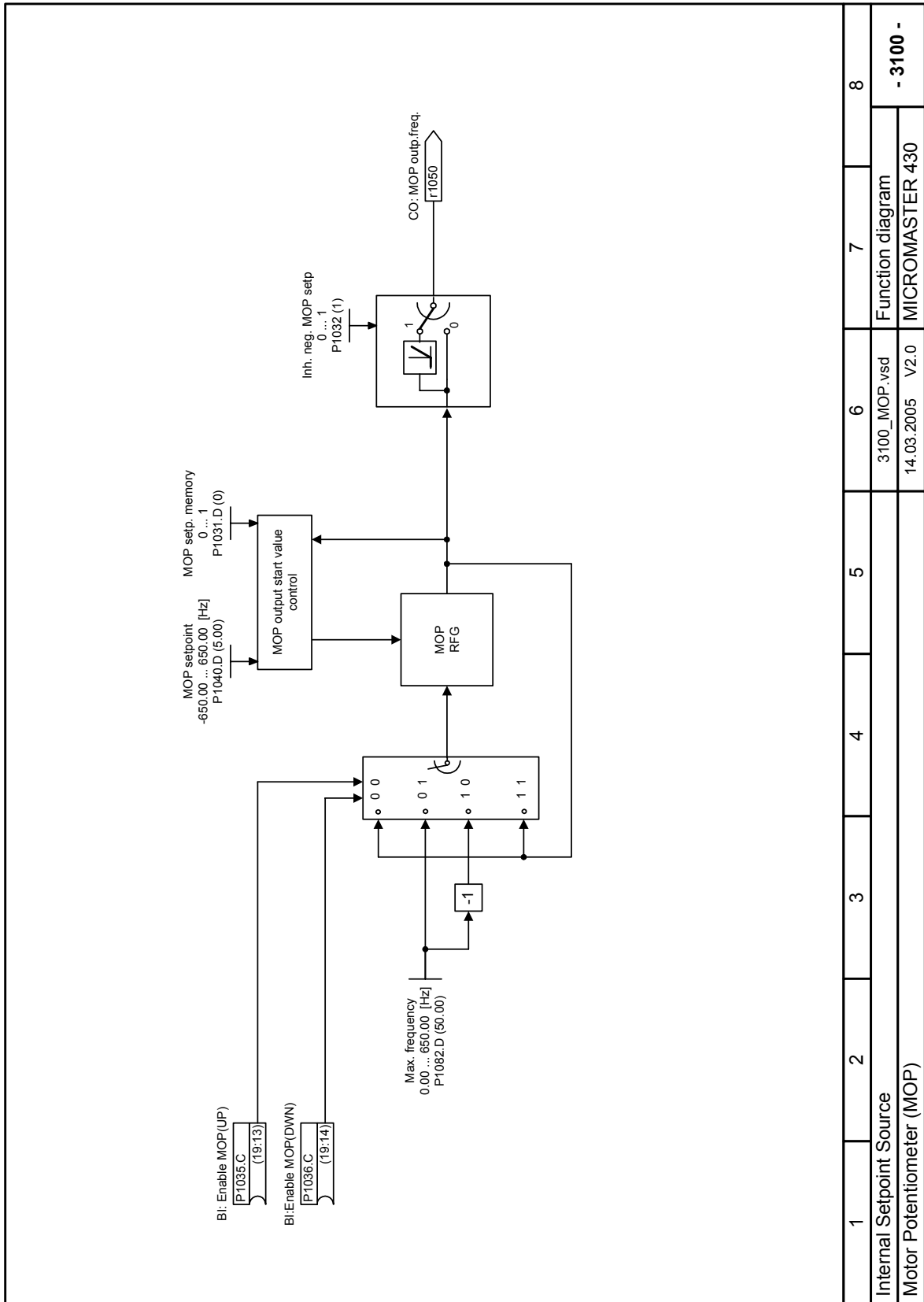

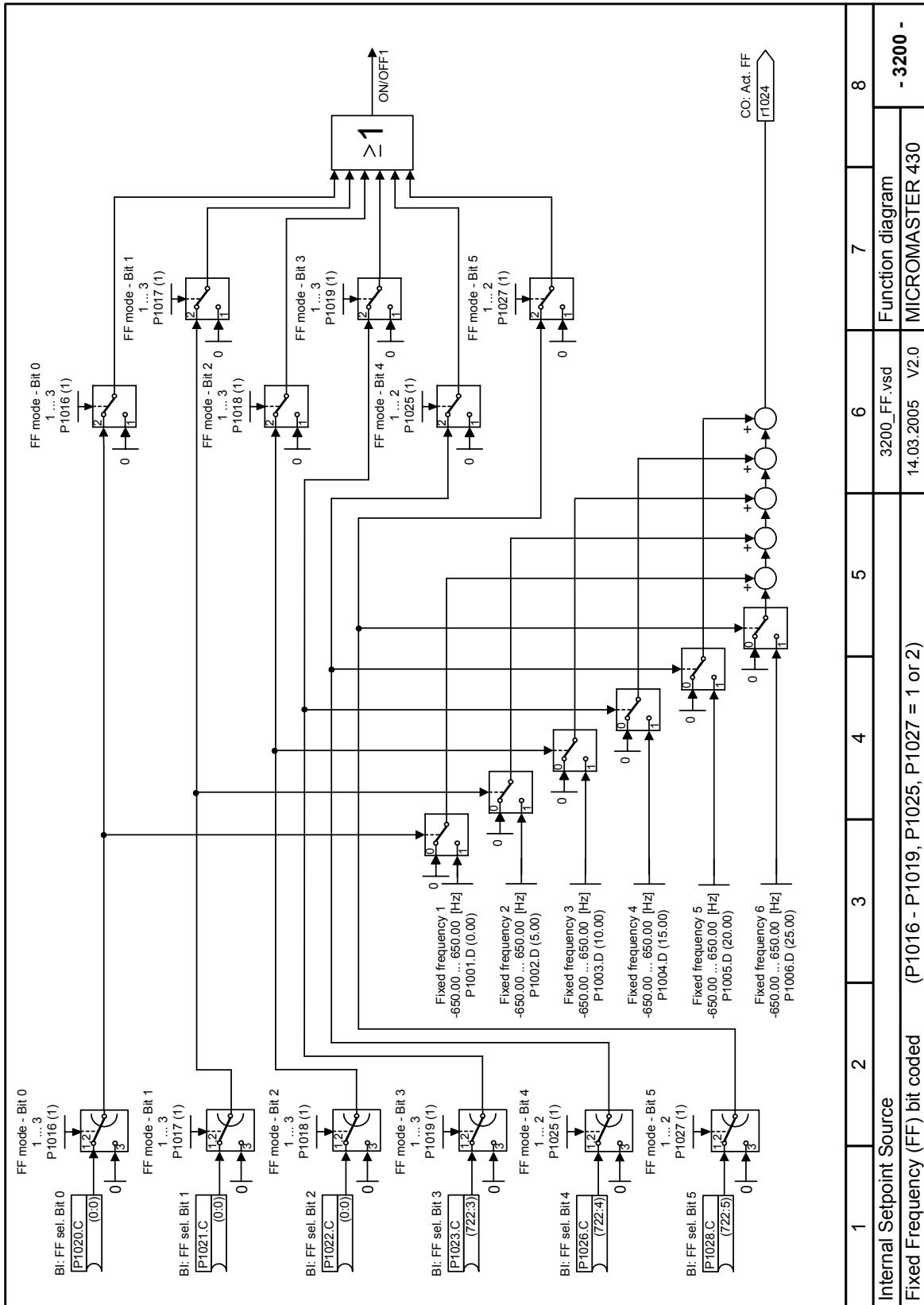

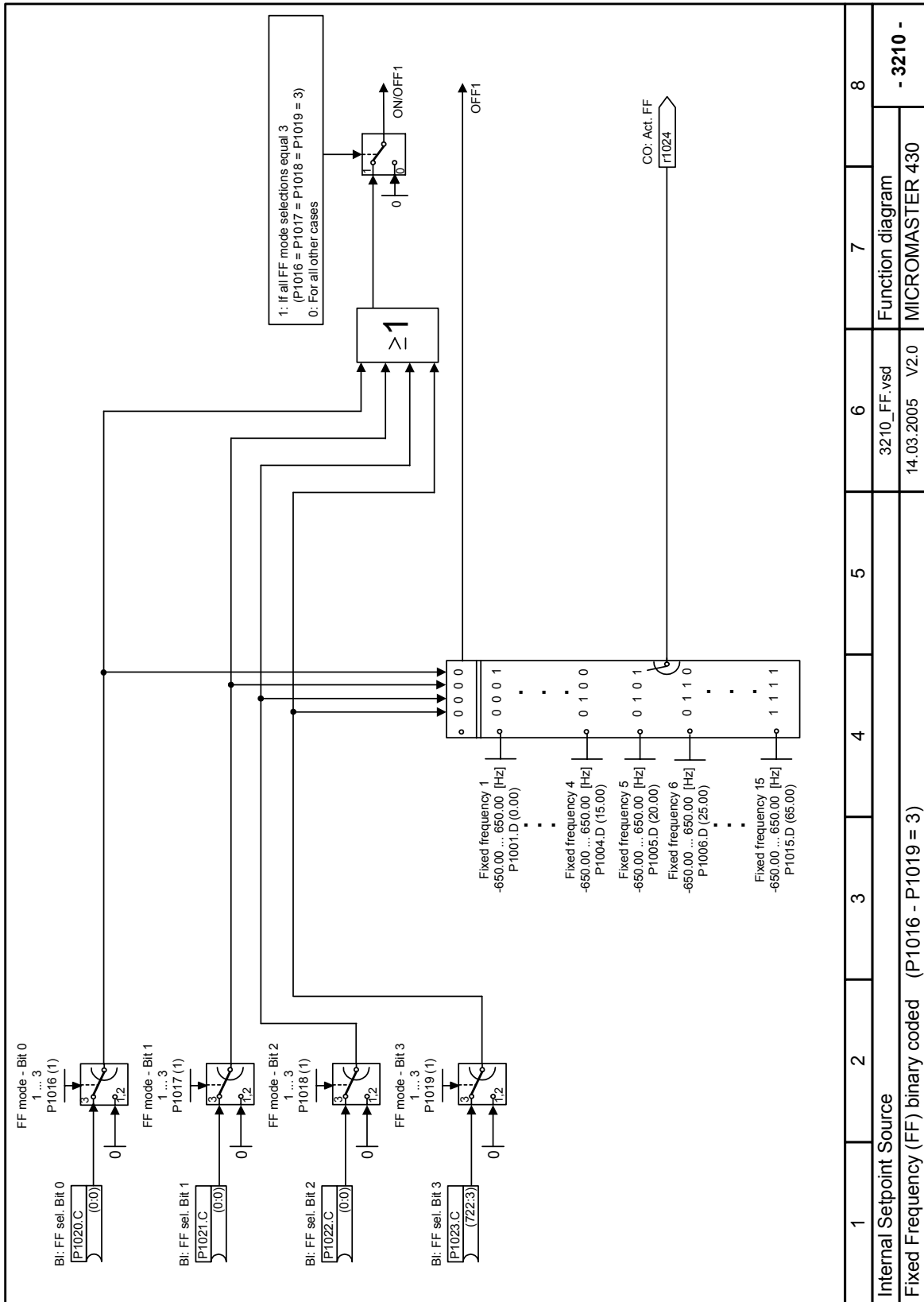

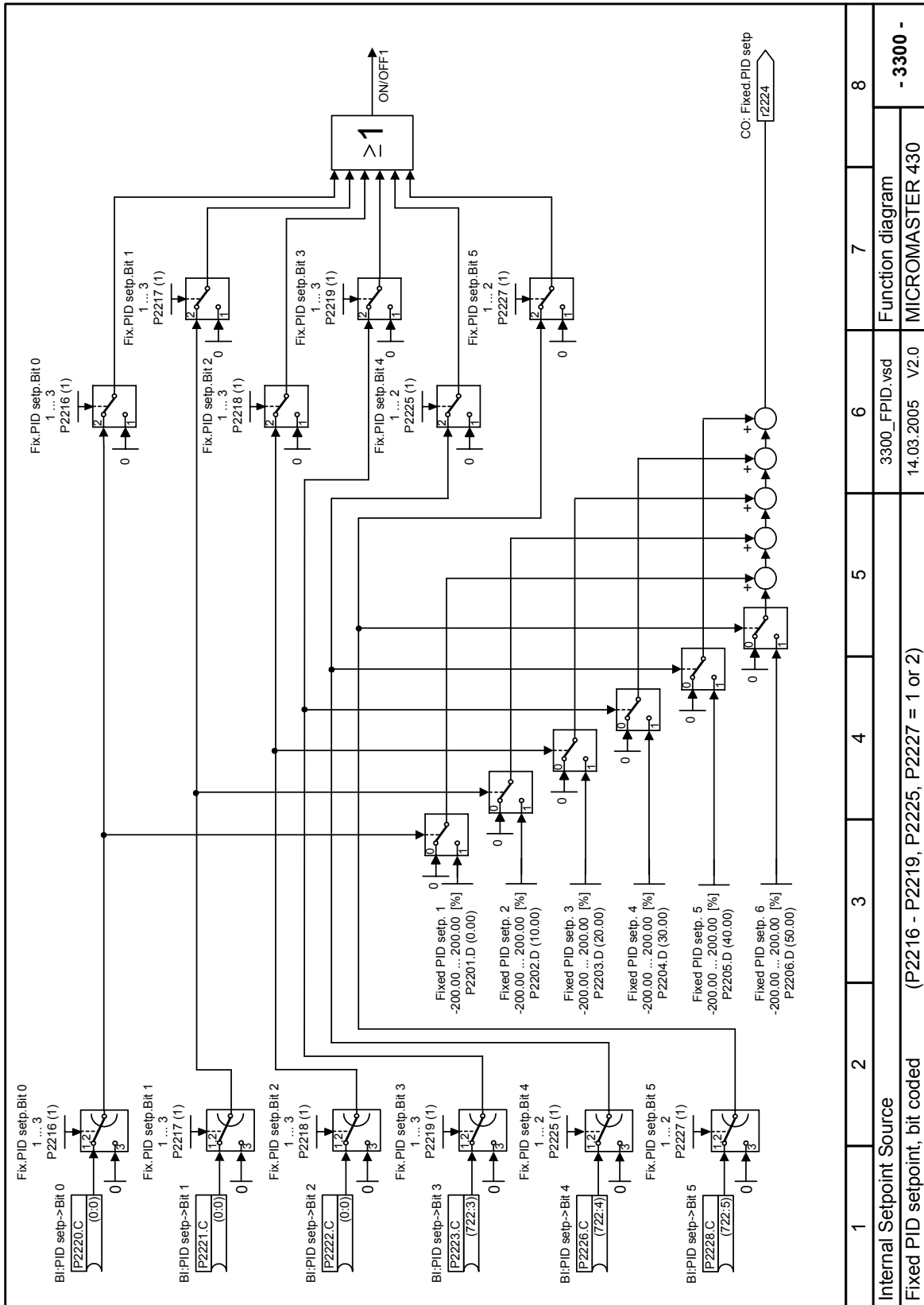

1	2	3	4	5	6	7	8
Internal Setpoint Source							
Fixed PID setpoint, bit coded (P2216 - P2219, P2225, P2227 = 1 or 2)							
3300_FPID.vsd						Function diagram	
14.03.2005 V2.0						MICROMASTER 430	
- 3300 -							

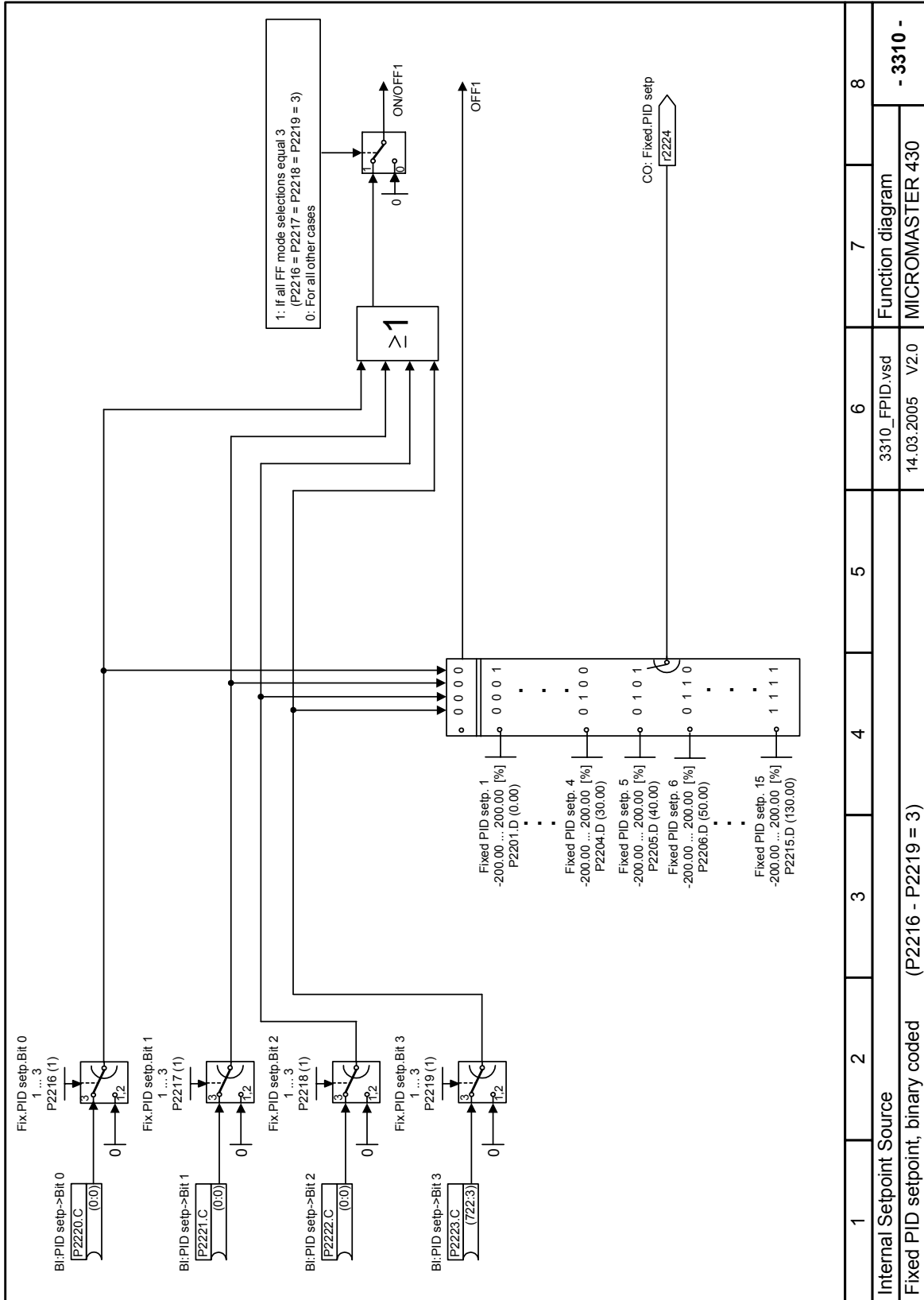

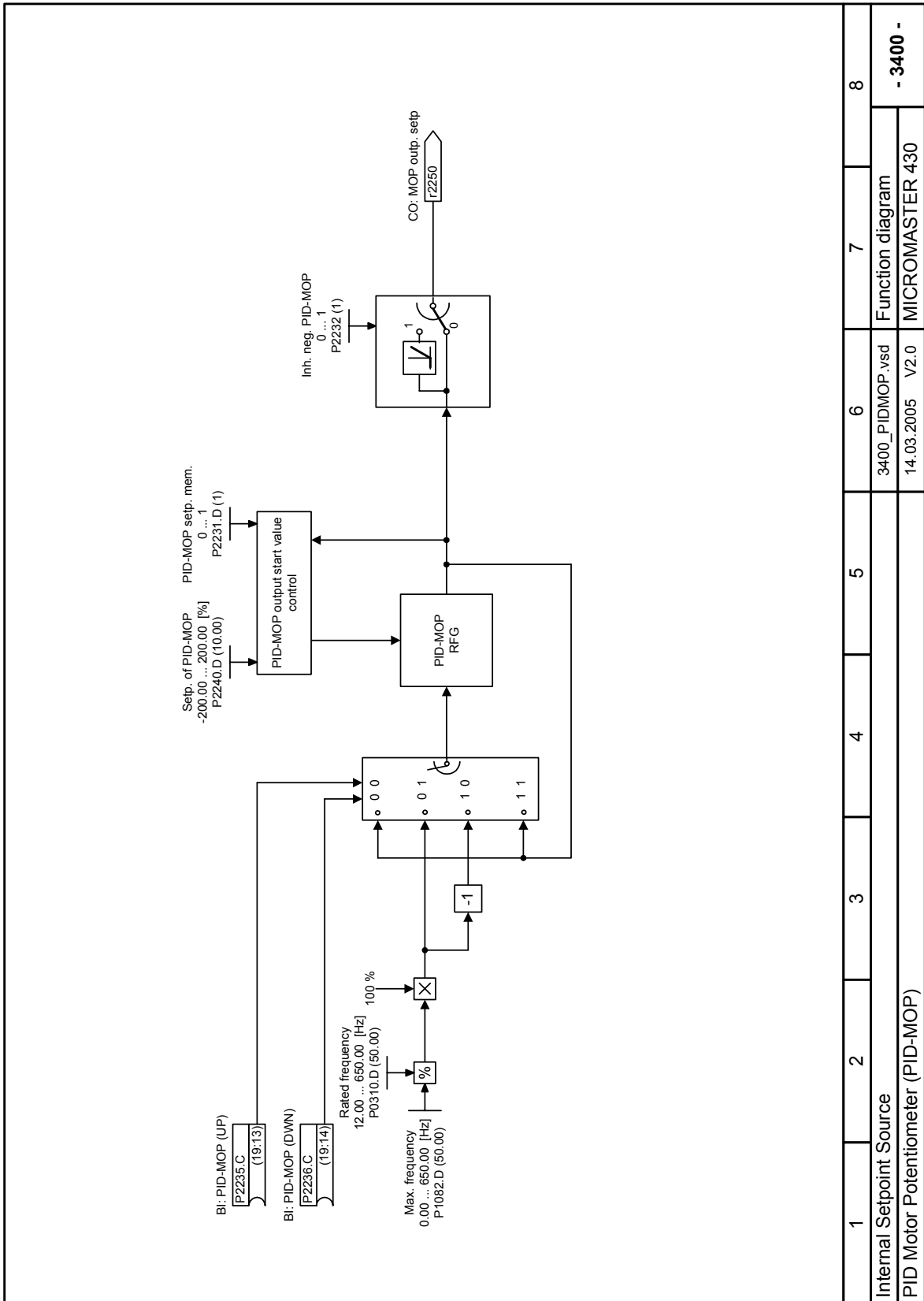

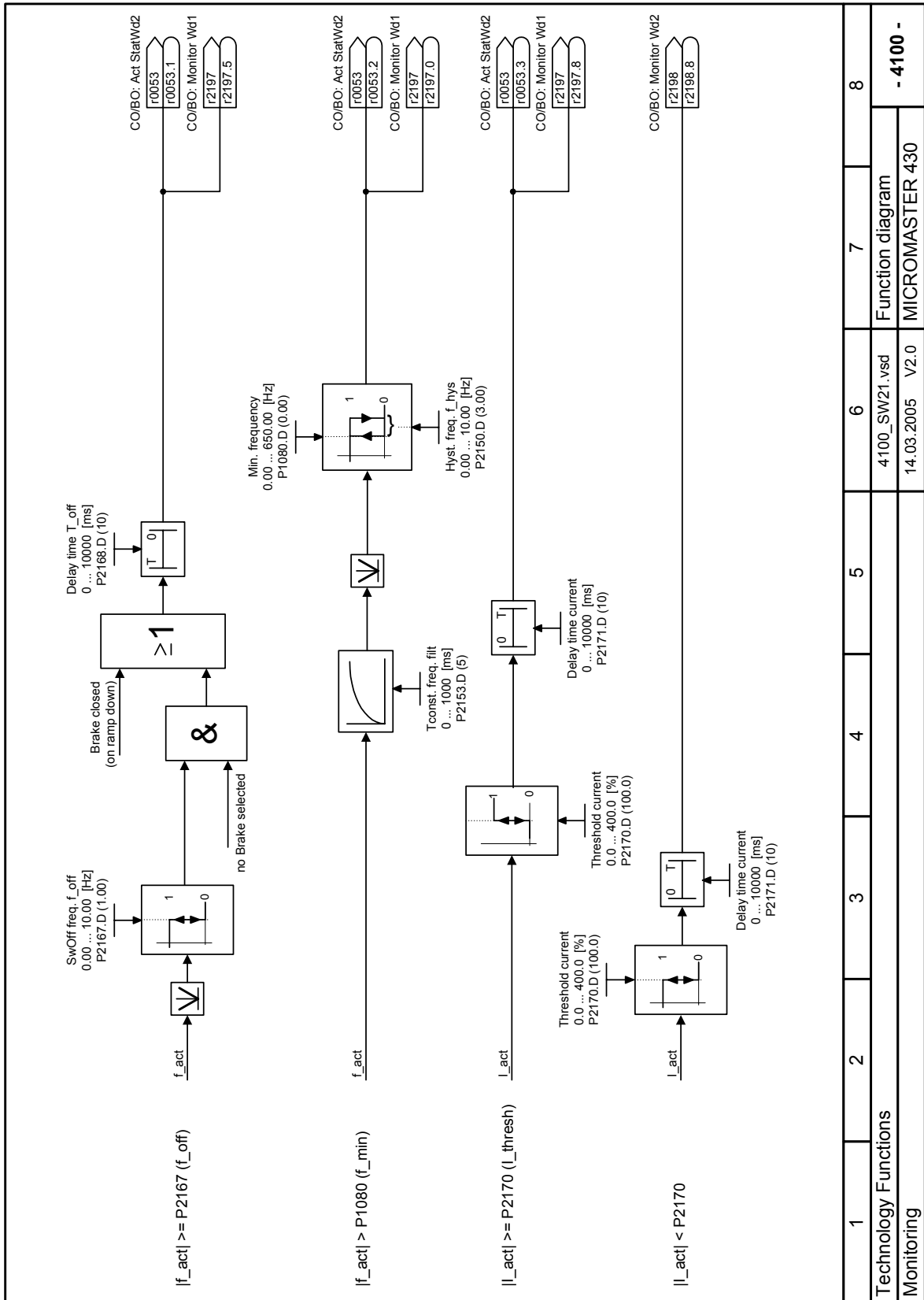

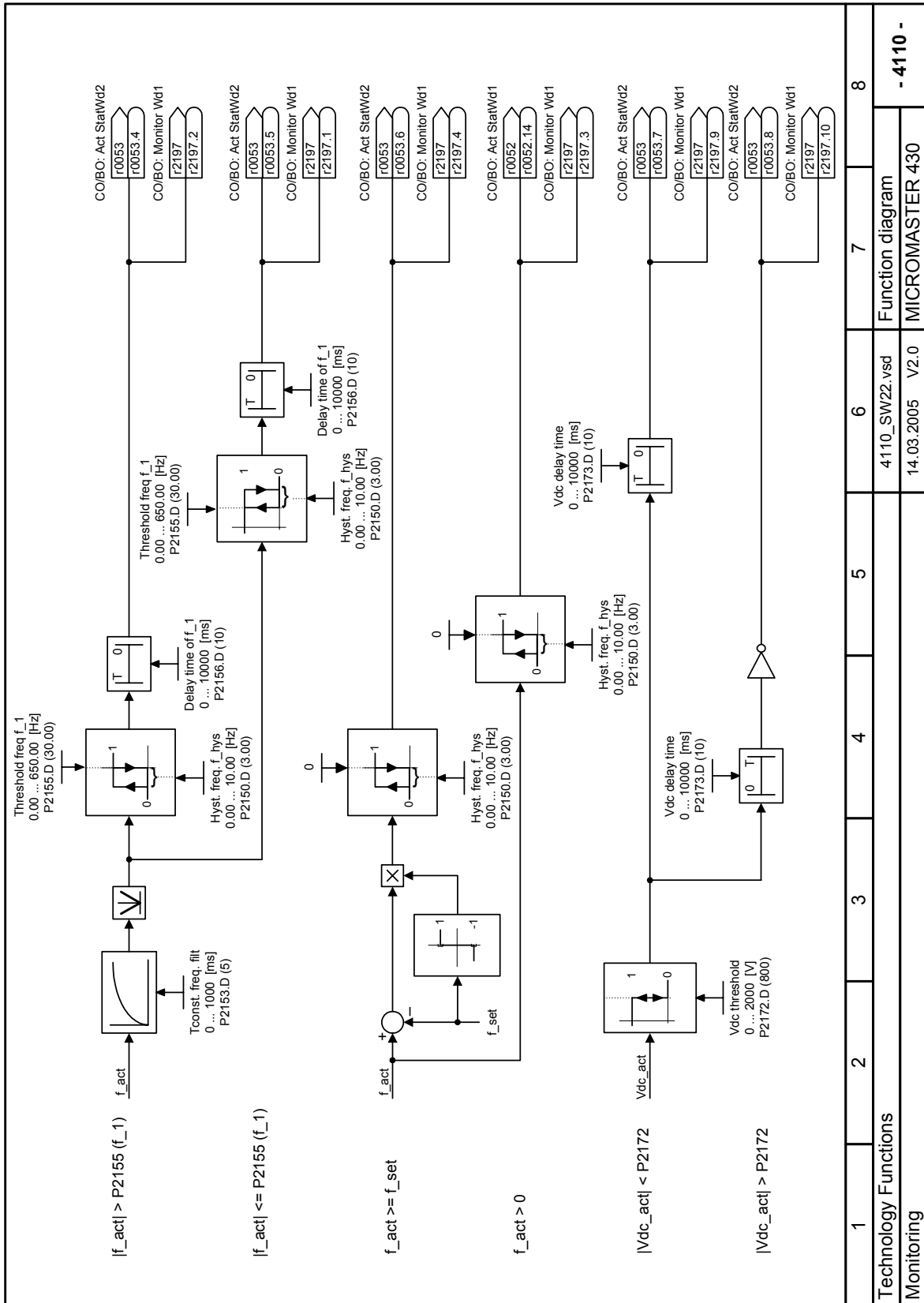

1	2	3	4	5	6	7	8
Technology Functions							
Monitoring							
Function diagram							
4110_SW22.vsd							
14.03.2005 V2.0							
- 4110 -							
MICROMASTER 430							

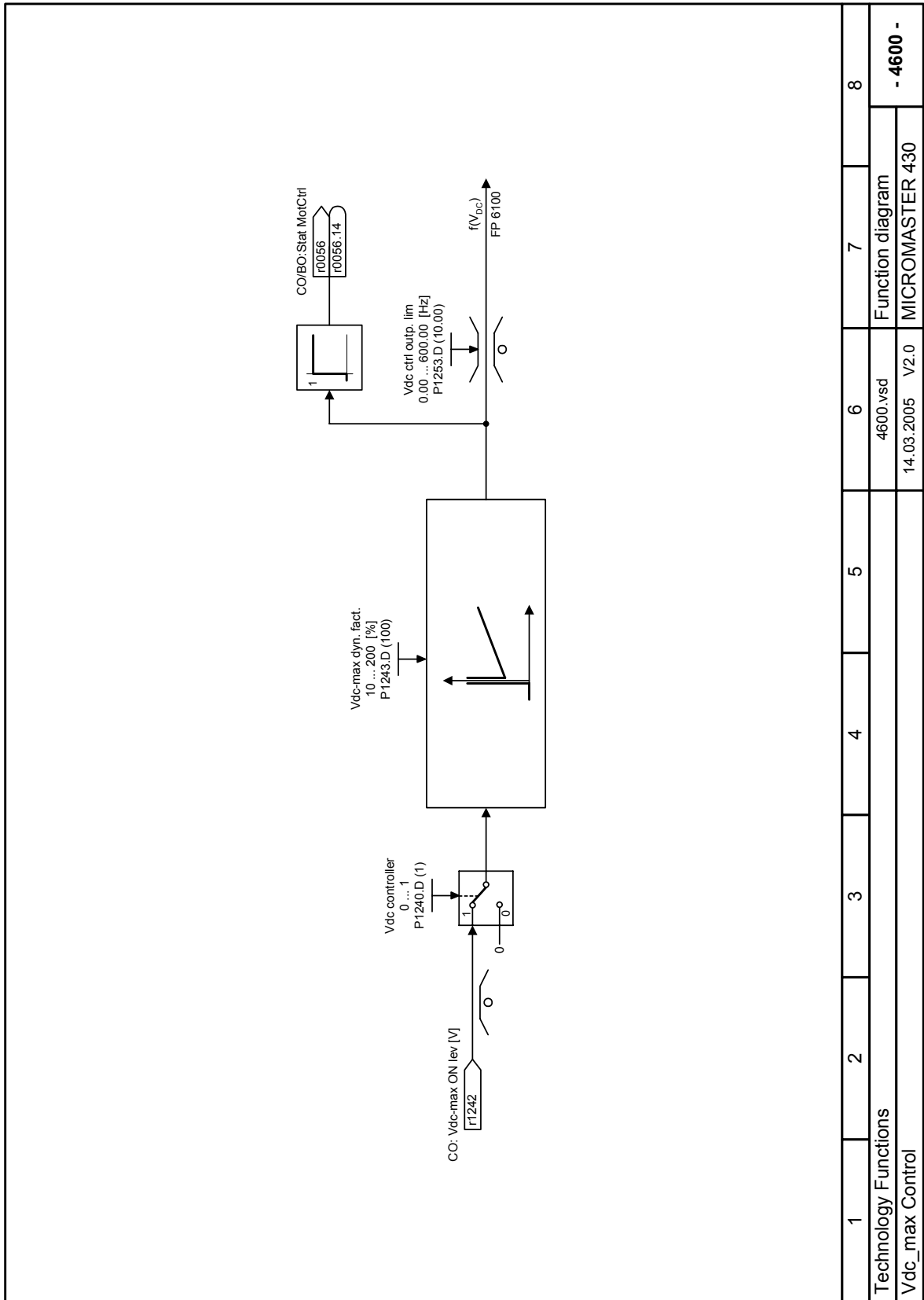

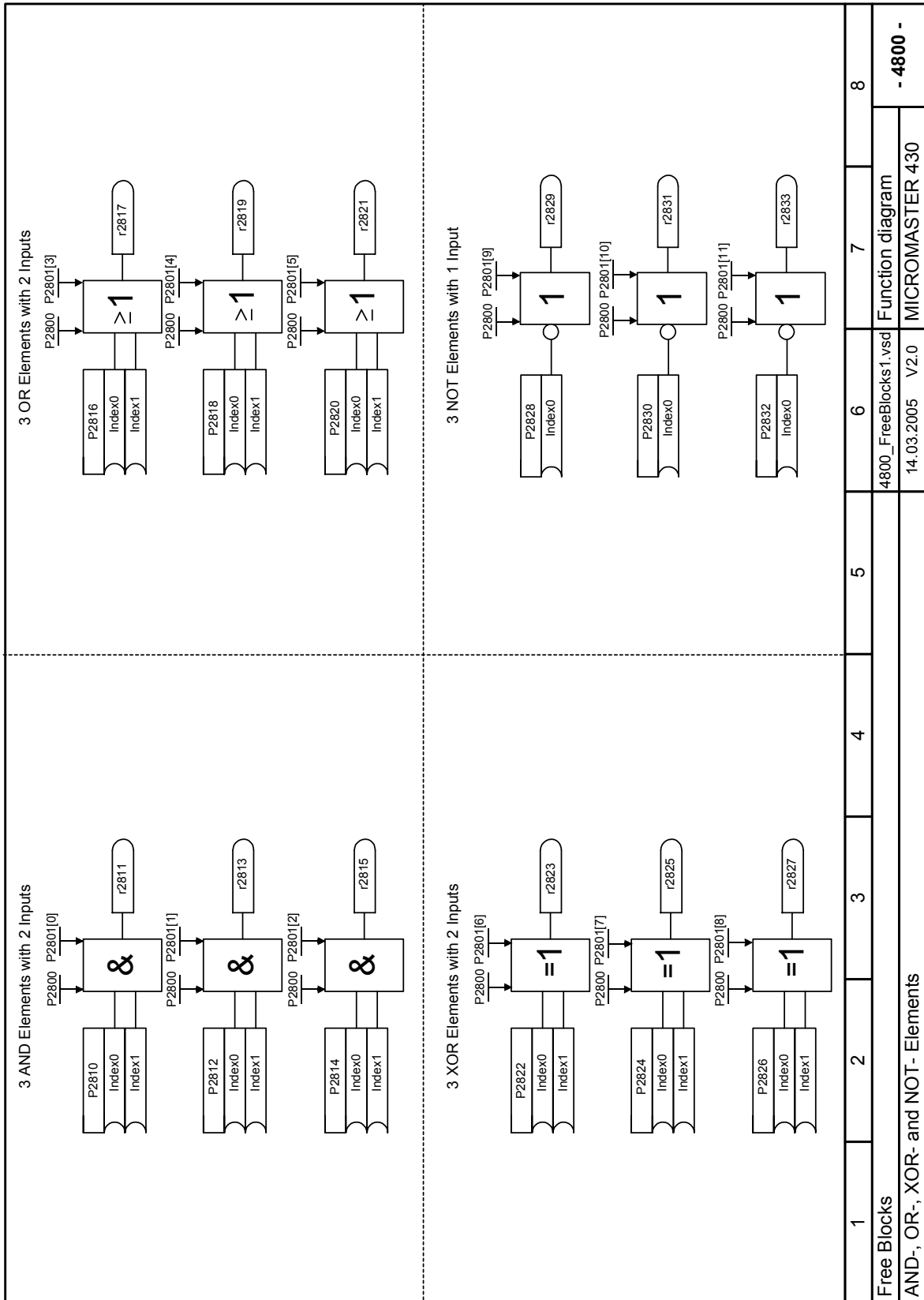

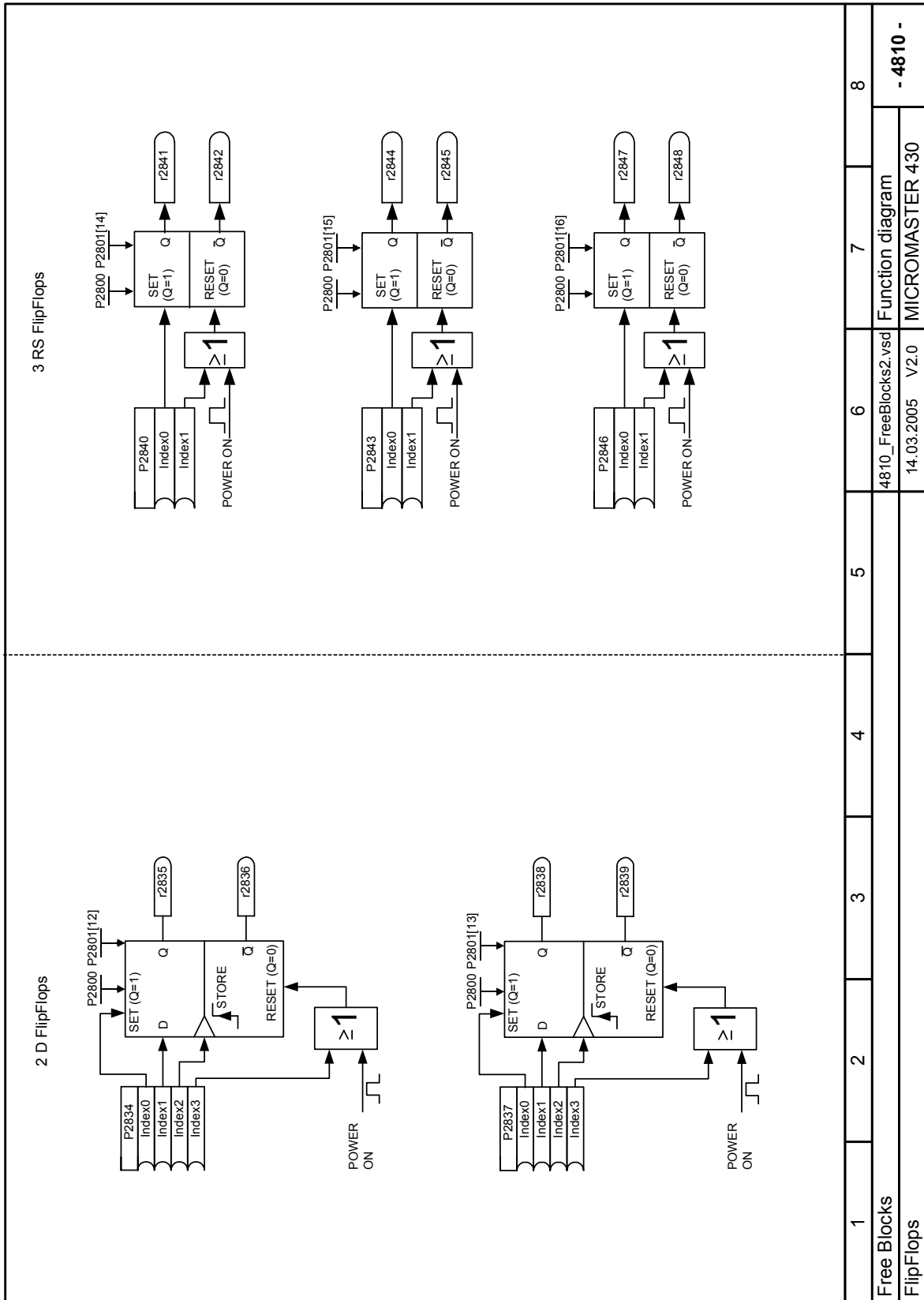

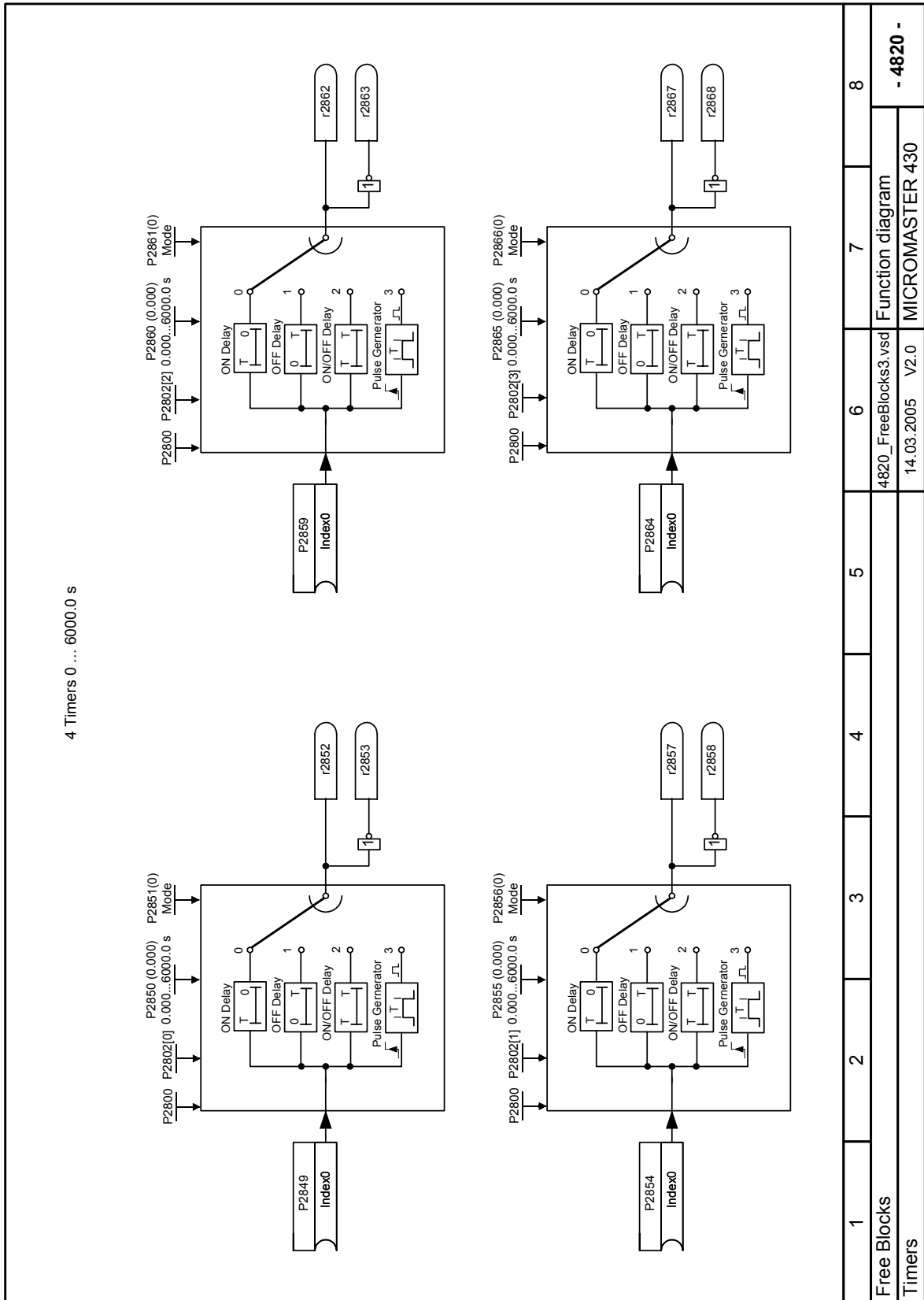

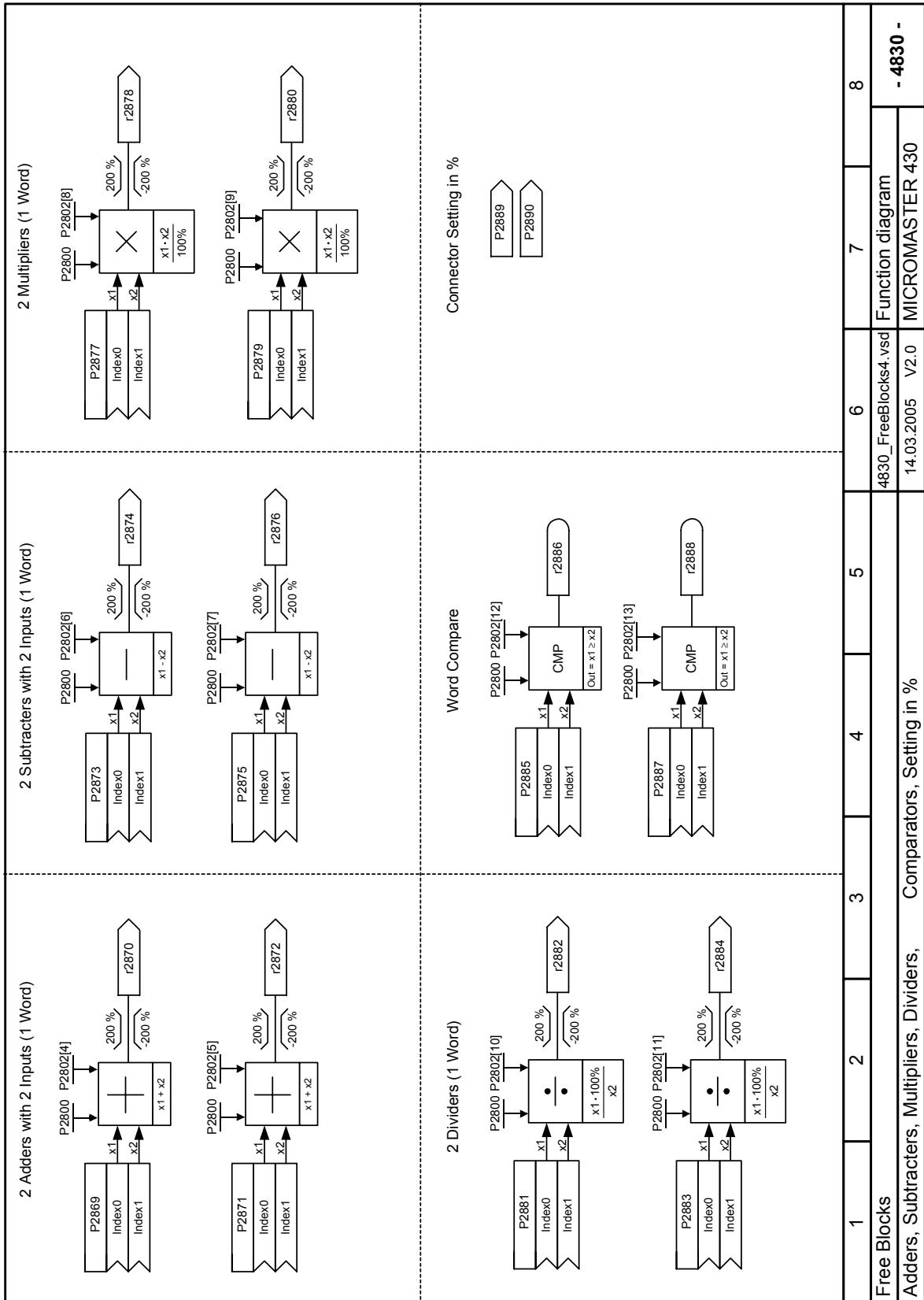

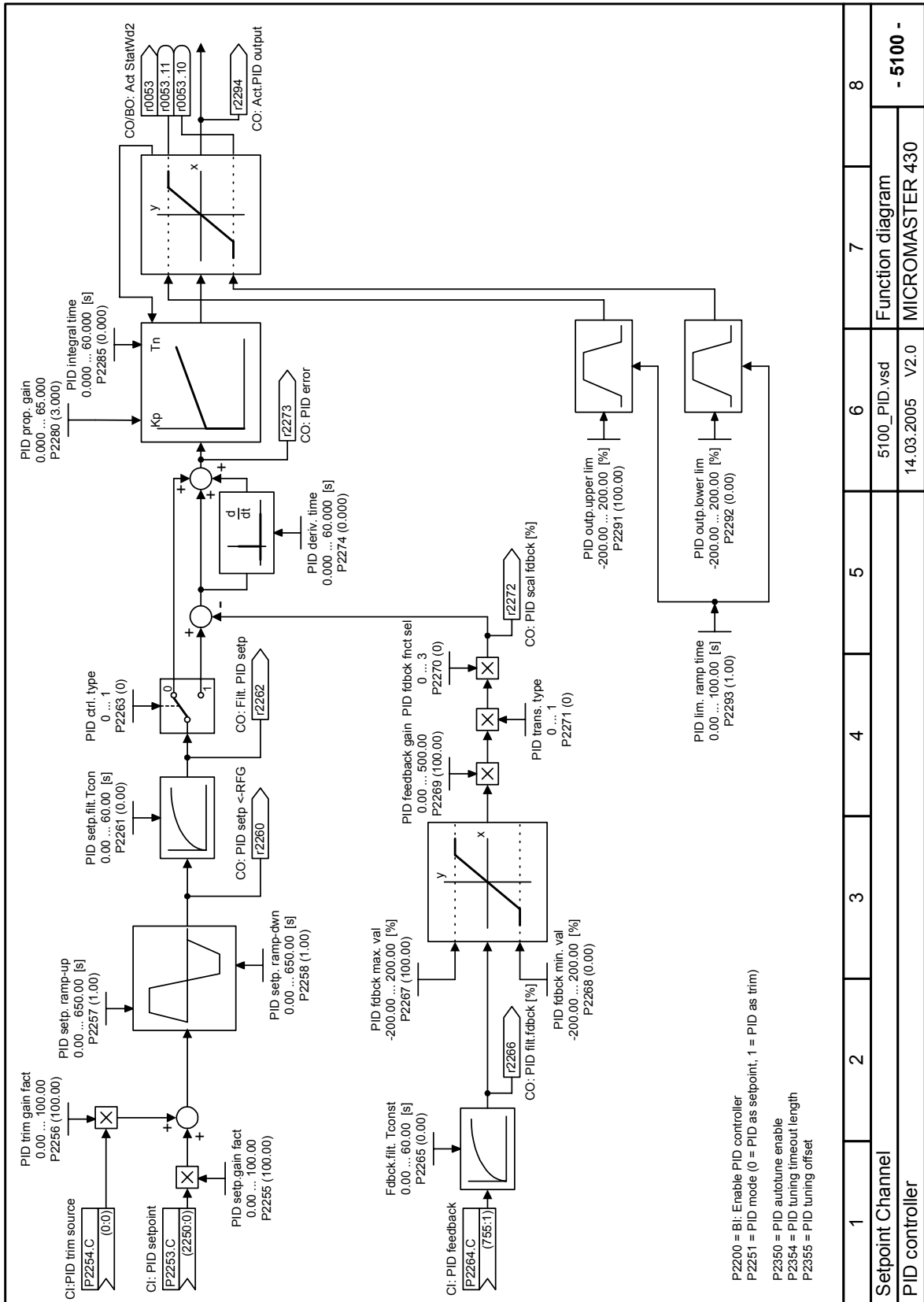

1	2	3	4	5	6	7	8	
Setpoint Channel					Function diagram			- 5100 -
PID controller					5100_PID.vsd	MICROMASTER 430		
					14.03.2005	V2.0		

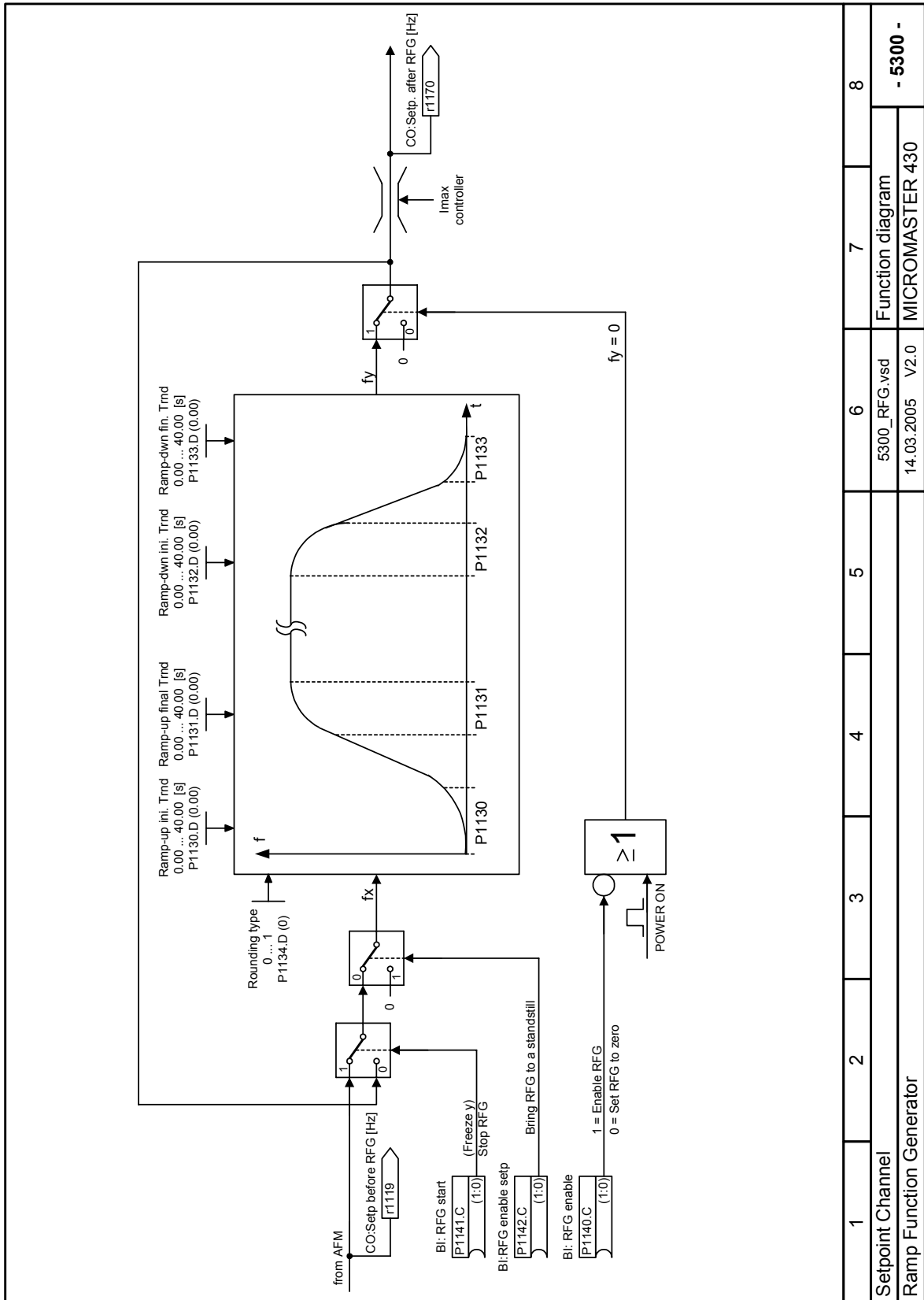

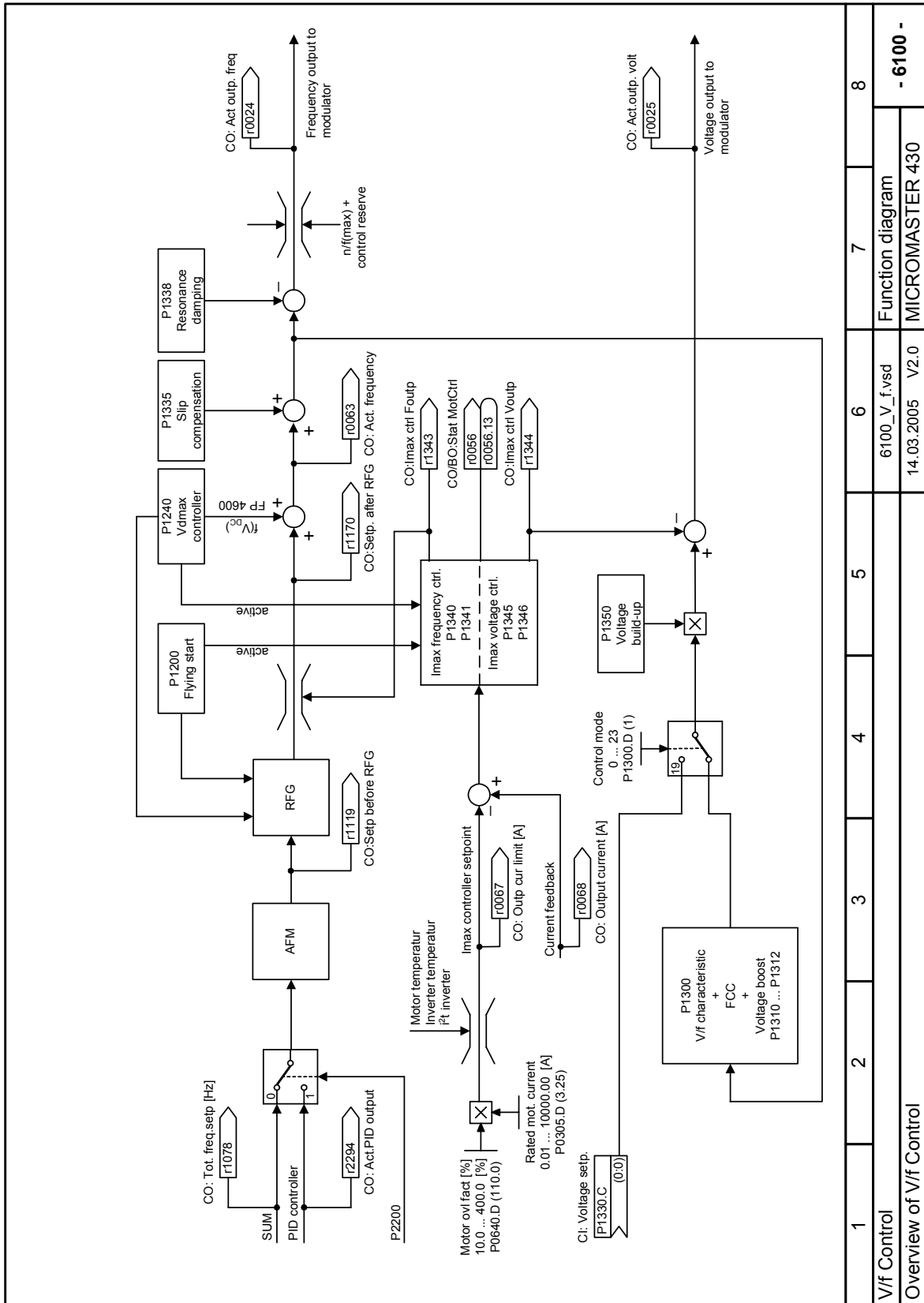

5 Faults and Alarms

5.1 Fault messages

In the event of a failure, the inverter switches off and a fault code appears on the display.

NOTE

To reset the fault code, one of three methods listed below can be used:

1. Cycle the power to the drive.
 2. Press the  button on the BOP-2.
 3. Via Digital Input 3 (default setting)
-

Fault messages are stored in parameter r0947 under their code number (e.g. F0003 = 3). The associated error value is found in parameter r0949. The value 0 is entered if a fault has no error value. It is furthermore possible to read out the point in time that a fault occurred (r0948) and the number of fault messages (P0952) stored in Parameter r0947.

F0001 Overcurrent STOP II

Quit

- Remove fault and reset fault memory by disconnecting the
- drive converter from the line supply and powering-up again
 - Press the Fn key on the BOP-2 or AOP
 - Acknowledge fault P2103, P2104
 - P0952 (complete fault memory)

Cause

- short-circuit at the output
- ground fault
- excessively large motor (the motor power rating P0307 is greater than the inverter power r0206)
- defective final stage (end stage)

Diagnosis & Remedy

Please check the following:

- are the cable lengths within the limit values ?
- does the motor cable or motor have either a short-circuit or ground fault ?
- do the motor parameters correspond to those of the motor being used ?
- is the motor overloaded or stalled (locked rotor) ?
- increase the accelerating time.
- reduce the gain
- use a motor with a lower power rating
- is the stator resistance value (P0350) correct ?

F0002 Overvoltage STOP II

Quit

Refer to F0001

Cause

- DC link voltage (r0026) higher than the overvoltage threshold (refer to parameter r0026)
- ground fault

Diagnosis & Remedy

Please check the following:

- is the line supply voltage within the permissible range?
 - has the DC current DC link monitoring been enabled (P1240) and correctly parameterized?
 - extend the deceleration ramp (ramp-down time P1121, P1135)
 - remove the ground fault
 - is the required braking power within the permissible limits?
-

NOTE

- a higher moment of inertia requires longer deceleration times; if required, use a braking resistor.
- overvoltage can either be caused by an excessively high line supply voltage or by the fact that the motor is generating (regenerative mode).
- the motor can be generating as it is decelerating quickly or due to the fact that an active load is driving the motor.

F0003 Undervoltage STOP II

Quit

Refer to F0001

Cause

- line voltage failed
- shock stressing outside the permissible limits.

Diagnosis & Remedy

Please check the following:

- is the line supply voltage within the permissible range?
- is the line supply voltage stable with respect to sporadic failures and voltage dips (brown-outs) ?

F0004 Inverter overtemperature STOP II

Quit

Refer to F0001

Cause

- inadequate cooling
- ambient temperature is too high.
- ambient temperature is too high.

Diagnosis & Remedy

Please check the following:

- is the pulse frequency P1800 set to the factory setting ? If required reset P1800.
- does the ambient temperature lie within the permissible limits ?
- reduce the load and / or ensure adequate cooling

Please check the following:

- does the fan rotate if the inverter is operational ?

F0005 Inverter I2T STOP II

Quit

Refer to F0001

Cause

- inverter overloaded.
- load duty cycle too high.
- the motor power rating (P0307) is greater than that of the inverter (r0206).
- 100 % overload reached (refer to utilization r0036)

Diagnosis & Remedy

Please check the following:

- does the load duty cycle lie within the permissible limits?
- use a motor with a lower rating (motor power P0307 is greater than Is inverter power r0206)

F0011 Motor overtemperature STOP II

Quit

Refer to F0001

Cause

Motor overloaded

Diagnosis & Remedy

Please check the following:

- is the load cycle correct ?
- are the rated/nominal motor overtemperatures correct (P0626-P0628) ?
- is the alarm threshold correct for the motor temperature (P0604) ?

F0012 No inverter temperature signal STOP I

Quit

Refer to F0001

Cause

- wire breakage of the inverter-temperature sensor (heatsink)

Diagnosis & Remedy

- replace the inverter

F0015 No motor temperature signal STOP II**Quit**

Refer to F0001

Cause

- motor temperature sensor either short-circuited or open-circuit.
- if it is identified that a signal has been lost, then the temperature monitoring changes-over to monitoring based on the thermal-motor model.

F0020 Line supply phase missing STOP II**Quit**

Refer to F0001

Cause

- a fault is output if one of the three input phases is missing, the pulses are enabled and a load is present

Diagnosis & Remedy

Please check the following:

- are the power connections ok ?

F0021 Ground fault STOP II**Quit**

Refer to F0001

Cause

- the fault occurs if the sum of the phase currents is greater than 5 % of the inverter rated current.

NOTE

- this fault only occurs for inverters with 3 current sensors (sizes D to F, GX, FX).

Diagnosis & Remedy

Please check the following:

- are the connections at the motor terminal boxes o.k. ?
- are the motor cable connections at the inverter o.k. ?

F0022 Hardware monitoring active STOP II**Quit**

Refer to F0001

Cause

This fault (r0947 = 22 and r0949 = 1) occurs under the following circumstances:

- (1) DC link overcurrent condition = IGBT short-circuit
- (2) Braking chopper short-circuit
- (3) Ground fault
- (4) I/O module not correctly inserted

For the following sizes the above faults can occur:

- size A to C (1),(2),(3),(4)
- size D to E (1),(2), (4)
- size F (1),(2)

The following faults only occur in conjunction with sizes FX / GX:

- UCE faults are identified if r0947 = 22 and the fault value r0949 = 12 or 13 or 14.
- I2C bus error is identified if r0947 = 22 and the fault value r0949 = 21 (power-down and then power-up again).

NOTE

All of these faults are assigned to a signal in the power module. This means that it is not possible to determine which fault actually occurred.

Diagnosis & Remedy

You must first identify as to whether the fault is permanent (i.e. the inverter cannot be started without the fault occurring) or it sporadically occurs (occasionally occurs or under certain operating conditions).

Permanent fault F0022:

- check whether the I/O module is correctly inserted (refer to the Operating Instructions).
- is there a ground fault or short-circuit at the inverter output or at an IGBT?

You can identify this by disconnecting the motor cable.

In the case that the fault occurs, if all of the external cables (with the exception from the line supply voltage) are disconnected, then with a high degree of probability, the drive unit is defective and must be repaired.

Sporadic fault F0022:

- this fault should be treated as "overcurrent". If fault F0022 sporadically occurs, the causes can be as follows:
- sudden load changes or mechanical obstructions
- extremely short ramp-up times (accelerating times)

F0023	Output fault	STOP II
	<p>Quit Refer to F0001</p> <p>Cause</p> <ul style="list-style-type: none"> - one output phase hasn't been correctly connected. <p>Diagnosis & Remedy Please check the following:</p> <ul style="list-style-type: none"> - are the connections at the motor terminal box o.k. ? - are the motor cable connections at the inverter o.k. ? 	
F0030	Fan failed	STOP II
	<p>Quit Refer to F0001</p> <p>Cause</p> <ul style="list-style-type: none"> - fan no longer functions <p>Diagnosis & Remedy</p> <ul style="list-style-type: none"> - fault cannot be suppressed if an AOP or BOP is connected. - a new fan is required. 	
F0035	Restart after n	STOP II
	<p>Quit reset fault memory or Power On / Stop</p> <p>Cause</p> <ul style="list-style-type: none"> - restart fault after n attempts, refer to P1211 	
F0041	Failure, motor data identification	STOP II
	<p>Quit Refer to F0001</p> <p>Cause Motor data identification run unsuccessful (refer to fault value r0949):</p> <ul style="list-style-type: none"> - r0949 = 0: Load missing. - r0949 = 1: Current limit value reached during identification. - r0949 = 2: Identified stator resistance less than 0.1% or greater than 100%. - r0949 = 30: Current controller at voltage limit value - r0949 = 40: Identified data set inconsistent; at least one identification run unsuccessful <hr/> <p>NOTE Percentage values based on the impedance $Z_b = V_{mot, rated} / \sqrt{3} / I_{mot, rated}$</p> <p>Diagnosis & Remedy Please check the following:</p> <ul style="list-style-type: none"> - r0949 = 0: Is the motor connected to the inverter ? - r0949 = 1-40: Is the motor data in P0304-P0311 correct ? - r0949 = 1-40: Motor circuit configuration correct (star, delta configuration) ? 	
F0051	Parameter EEPROM fault	STOP II
	<p>Quit Refer to F0001</p> <p>Cause</p> <ul style="list-style-type: none"> - read or write operation while saving parameters in the EEPROM was unsuccessful. <p>Diagnosis & Remedy</p> <ul style="list-style-type: none"> - reset to factory setting and then re-parameterize - if required, change the drive 	
F0052	Power stack fault	STOP II
	<p>Quit Refer to F0001</p> <p>Cause</p> <ul style="list-style-type: none"> - read error, power data or invalid power module data. <p>Diagnosis & Remedy</p> <ul style="list-style-type: none"> - change the drive 	

F0053	I/O EEPROM fault	STOP II
	<p>Quit Refer to F0001</p> <p>Cause</p> <ul style="list-style-type: none"> - fault with I/O EEPROM read operation or invalid data. <p>Diagnosis & Remedy Please check the following:</p> <ul style="list-style-type: none"> - check I/O data and if required repeat the operation - the installation of the I/O module in the inverter if required, replace the I/O module 	
F0054	Incorrect I/O module	STOP II
	<p>Quit Refer to F0001</p> <p>Cause</p> <ul style="list-style-type: none"> - incorrect I/O module inserted. - no ID of the I/O module found, no data. <p>Diagnosis & Remedy Please check the following:</p> <ul style="list-style-type: none"> - check I/O data, if required repeat the operation - the installation of the I/O module in the inverter if required, replace the I/O module 	
F0060	Asic time slice overflow	STOP II
	<p>Quit Refer to F0001</p> <p>Cause</p> <ul style="list-style-type: none"> - internal communications failure/error <p>Diagnosis & Remedy</p> <ul style="list-style-type: none"> - if the error still occurs, replace the inverter. - contact customer service! 	
F0070	CB setpoint fault	STOP II
	<p>Quit Refer to F0001</p> <p>Cause</p> <ul style="list-style-type: none"> - no setpoints received via the communications bus during the telegram failure time. <p>Diagnosis & Remedy</p> <ul style="list-style-type: none"> - check the communications module (CB) and communications partner. 	
F0071	USS(BOP link) setpoint fault	STOP II
	<p>Quit Refer to F0001</p> <p>Cause</p> <ul style="list-style-type: none"> - no setpoint was received via the USS during the telegram off time <p>Diagnosis & Remedy</p> <ul style="list-style-type: none"> - check USS master 	
F0072	USS(COMM link) setpoint fault	STOP II
	<p>Quit Refer to F0001</p> <p>Cause</p> <ul style="list-style-type: none"> - no setpoints received via the USS during the telegram off time <p>Diagnosis & Remedy</p> <ul style="list-style-type: none"> - check USS master 	
F0080	ADC input signal lost	STOP II
	<p>Quit Refer to F0001</p> <p>Cause</p> <ul style="list-style-type: none"> - wire breakage - signal outside the limit values 	

F0085	External fault	STOP II
	<p>Quit Refer to F0001</p> <p>Cause</p> <ul style="list-style-type: none"> - external fault as a result of command input via terminals. <p>Diagnosis & Remedy</p> <ul style="list-style-type: none"> - inhibit terminal input to initiate fault. 	
F0090	Signal loss, encoder	STOP II
	<p>Quit Refer to F0001</p> <p>Cause</p> <ul style="list-style-type: none"> - encoder signal between the encoder and inverter is interrupted - excessively large difference between the setpoint (reference) and actual frequency <p>Diagnosis & Remedy Please check the following:</p> <ul style="list-style-type: none"> - is there an integrated encoder? - the connection between the encoder and the inverter - is the encoder faulty? (select P1300 = 0, operation with fixed speed, check the encoder signal in r0061) - increase the encoder signal threshold in P0492, P0494 	
F0101	Stack overflow	STOP II
	<p>Quit Refer to F0001</p> <p>Cause</p> <ul style="list-style-type: none"> - software error or processor failure <p>Diagnosis & Remedy</p> <ul style="list-style-type: none"> - carry-out self-test routines 	
F0221	PID feedback below the minimum value	STOP II
	<p>Quit Refer to F0001</p> <p>Cause</p> <ul style="list-style-type: none"> - PID feedback below the minimum value P2268. <p>Diagnosis & Remedy</p> <ul style="list-style-type: none"> - change value of P2268. - set feedback gain. 	
F0222	PID feedback above maximum value	STOP II
	<p>Quit Refer to F0001</p> <p>Cause</p> <ul style="list-style-type: none"> - PID feedback above maximum value P2267. <p>Diagnosis & Remedy</p> <ul style="list-style-type: none"> - change value of P2267. - set the feedback gain. 	
F0450	Failure BIST tests	STOP II
	<p>Quit Refer to F0001</p> <p>Cause Self-test routine unsuccessful (refer to fault value r0949):</p> <ul style="list-style-type: none"> - r0949 = 1: Self-test routine for power module components unsuccessful - r0949 = 2: Self-test routine for closed-loop control module components unsuccessful - r0949 = 4: Several function tests were unsuccessful - r0949 = 8: Several tests carried-out at the I/O module were unsuccessful (only MICROMASTER 420) - r0949 = 16: Failure of the internal RAM at the switch-on test <p>Diagnosis & Remedy</p> <ul style="list-style-type: none"> - the drive is functional, but several functions are not correctly executed. - replace the drive 	

F0452 Load torque fault detected**STOP II****Quit**

Refer to F0001

Cause

- load conditions at the motor signify a load torque fault (e.g. belt failure) or a mechanical fault

Diagnosis & Remedy

Please check the following:

- no braking, failure or destruction of the mechanical drive transmission line
- if required, lubricate the mechanical drive transmission line.

If you are using an external encoder, please check the following parameter settings:

- P2192 (delay time, load torque monitoring)

If you are operating within a specific speed range, please check the following:

- P2182 (load torque monitoring F1)
- P2183 (load torque monitoring F1f2)
- P2184 (load torque monitoring F1f3)
- P2185 (upper torque threshold 1)
- P2186 (lower torque threshold 1)
- P2187 (upper torque threshold 2)
- P2188 (lower torque threshold 2)
- P2189 (upper torque threshold 3)
- P2190 (lower torque threshold 3)
- P2192 (delay time, load torque monitoring)

5.2 Alarm Messages

Alarm messages are stored in parameter r2110 under their code number (e.g. A0503 = 503) and can be read out from there.

A0501 Current limit value**Cause**

- the motor power rating does not correspond to the inverter power rating
- motor cables are too long
- ground fault

Diagnosis & Remedy

Please check the following:

- does the motor power rating (P0307) match the inverter power rating (r0206) ?
- are the limit values for the cable lengths maintained ?
- does the motor cable or motor have a short-circuit or ground fault ?
- do the motor parameters correspond to those of the motor being used ?
- stator resistance value (P0350) correct ?
- is the motor overloaded or is the rotor locked (cannot rotate) ?
- ramp-up time P1120 too low ?

A0502 Overvoltage limit value**Cause**

- the overvoltage limit value has been reached (actual value of the DC link voltage r0026 greater than r1242).

Diagnosis & Remedy

- if this alarm is permanently displayed, check the inverter input voltage.
- is the DC link voltage controller (Vdc_max controller) de-activated (refer to parameter P1240) ?
- short ramp times and/or large flywheel masses (moment of inertia) ?

A0503 Undervoltage limit value**Cause**

- line supply has failed.
- line voltage and therefore also the DC link voltage (r0026) below the defined limit value (refer to parameter r0026).

Diagnosis & Remedy

- check the line voltage.

A0504 Inverter overtemperature**Cause**

- alarm threshold of the inverter heatsink temperature (P0614) was exceeded; this results in a reduction of the pulse frequency and/or the output frequency (dependent on the parameterization in (P0610).

Diagnosis & Remedy

Please check the following:

- is the ambient temperature within the permissible limits ?
- are the load and load duty cycle within the permissible limits ?

A0505 Inverter I2T**Cause**

- overload alarm limit P0294 is exceeded (refer to utilization r0036)
- the pulse frequency and/or the output frequency is reduced as a function of the setting of parameter P0290.

Diagnosis & Remedy

- check whether the load duty cycle lies within the permissible limits.

A0511 Motor overtemperature**Cause**

- motor is overloaded.
- load duty cycle is exceeded.

Diagnosis & Remedy

Check, independently of the type of temperature monitoring:

- P0604 alarm threshold, motor overtemperature
- P0625 motor ambient temperature

If P0601 = 0 or 1, please check the following:

- is the motor data correct (rating plate)?, if not, carry-out a fast commissioning routine
- precise temperature values from the motor identification routine (P1910=1).
- is the motor weight correct (P0344)?
- the permissible overtemperature can be changed using P0626, P0627, P0628, if the motor is not a standard Siemens motor.

If P0601 = 2, then please check the following:

- is the temperature displayed in r0035 plausible?
- is an KTY84 temperature sensor being used? (others are not supported).

A0522 Read I2C, time exceeded**Cause**

- cyclic access to UCE values and power module data via i2c bus (only for sizes FX and GX) is faulted.

A0523 Output fault**Cause**

- an output cable is not connected.

Diagnosis & Remedy

- alarm can be suppressed.

A0541 Motor data identification routine active**Cause**

- motor data identification routine (P1910) selected and is active

A0590 Alarm, no signals from the speed encoder**Cause**

- no speed encoder signals

Diagnosis & Remedy

Stop the inverter, and

- check the speed encoder, if an encoder is not being used, set P0400 to 0
- check the encoder connections
- check whether the encoder is operating correctly (set P1300 = 0 and operate the drive at a fixed speed and check the encoder signal in r0061
- increase the permissible speed deviation in P0492

A0600 RTOS data loss alarm**Cause**

- time slice overflow was identified

Diagnosis & Remedy

- use lower baud rate for USS
- de-activate inverter functions

A0700 CB alarm 1**Cause**

- CB-(communications module)-specific

Diagnosis & Remedy

- refer to the CB User Manual

A0701 CB alarm 2**Cause**

- CB-(communications module)-specific

Diagnosis & Remedy

- refer to the CB User Manual

A0702 CB alarm 3**Cause**

- CB-(communications module)-specific

Diagnosis & Remedy

- refer to the CB User Manual

A0703 CB alarm 4**Cause**

- CB-(communications module)-specific

Diagnosis & Remedy

- refer to the CB User Manual

A0704 CB alarm 5**Cause**

- CB-(communications module)-specific

Diagnosis & Remedy

- refer to the CB User Manual

A0705 CB alarm 6**Cause**

- CB-(Communications module)-specific

Diagnosis & Remedy

- refer to the CB User Manual

A0706 CB alarm 7**Cause**

- CB-(Communications module)-specific

Diagnosis & Remedy

- refer to the CB User Manual

A0707 CB alarm 8**Cause**

- CB-(Communications module)-specific

Diagnosis & Remedy

- refer to the CB User Manual

A0708 CB alarm 9**Cause**

- CB-(Communications module)-specific

Diagnosis & Remedy

- refer to the CB User Manual

A0709 CB alarm 10**Cause**

- CB-(Communications module)-specific

Diagnosis & Remedy

- refer to the CB User Manual

A0710 CB communications error**Cause**

- loss of communications with the CB (communications module)

Diagnosis & Remedy

- check the CB hardware

A0711 CB communications error**Cause**

- CB (communications module) signals a communications error.

Diagnosis & Remedy

- check the CB parameters

A0910 Vdc-max controller disabled/switched-out**Cause**

- Vdc max controller was de-activated, as it was not able to keep the DC link voltage (r0026) within the limit values (refer to r0026 and P1240).
This occurs,
 - if the line supply voltage is permanently too high.
 - if the motor is driven by an active load, which means that the motor goes into regenerative operation.
 - while decelerating (short down-ramps P1121) for extremely high load torques

Diagnosis & Remedy

Please check the following:

- is the input voltage (P0756) within the permissible range ?
- are load duty cycle and load limits within the permissible limits ?

A0911 Vdc-max controller active**Cause**

- Vdc max controller is active
- the ramp-down times are automatically increased in order to keep the DC link voltage (r0026) within the limit values (refer to r0026 and P1240).

A0912 Vdc-min controller active**Cause**

- Vdc min controller is activated, if the DC link voltage (r0026) falls below the minimum value (refer to r0026 or P1240).
- the kinetic energy of the motor is used to buffer the DC link voltage and therefore to slow down the drive.
- therefore brief line failures no longer automatically result in an undervoltage trip.

A0920 ADC parameters not correctly set.**Cause**

ADC parameters should not be set to identical values, as this would lead to illogical results.

- Index 0: Parameter settings for output identical.
- Index 1: Parameter settings for input identical.
- Index 2: Parameter settings for input do not correspond to ADC type.

A0921 DAC parameters not correctly set.**Cause**

ADC parameters should not be set to identical values, as this would lead to illogical results.

- Index 0: Parameter settings for output identical.
- Index 1: Parameter settings for input identical.
- Index 2: Parameter settings for input do not correspond to ADC type.

A0922 No load at the inverter**Cause**

- no load is connected to the inverter.
- therefore several functions can run differently than under normal load conditions.

A0923 JOG counter-clockwise as well as JOG clockwise are requested**Cause**

- both JOG clockwise and JOG counter-clockwise (P1055/P1056) have been requested. This is the reason that the RFG output frequency has been frozen to the actual value.

A0952 Load fault detected**Cause**

- load conditions at the motor indicate a load fault or mechanical fault.

Diagnosis & Remedy

Please check the following:

- no braking, failure or destruction of the mechanical transmission line
- if required, lubricate the mechanical transmission line.

If you are using an external encoder, please check the following parameter settings:

- P2192 (delay time, load torque monitoring)

If you are using a specific speed range, then please check the following:

- P2182 (load torque monitoring F1)
- P2183 (load torque monitoring F1f2)
- P2184 (load torque monitoring F1f3)
- P2185 (upper torque threshold 1)
- P2186 (lower torque threshold 1)
- P2187 (upper torque threshold 2)
- P2188 (lower torque threshold 2)
- P2189 (upper torque threshold 3)
- P2190 (lower torque threshold 3)
- P2192 (delay time, load torque monitoring)

6 Abbreviations

AC	Alternating current
AD	Analog digital converter
ADC	Analog digital converter
ADR	Address
AFM	Additional frequency modification
AG	Automation unit
AIN	Analog input
AOP	Advanced operator panel
AOUT	Analog output
ASIC	Application-specific integrated circuit
ASP	Analog setpoint
ASVM	Asymmetric space vector modulation
BCC	Block check character
BCD	Binary-coded decimal code
BI	Binector input
BICO	Binector / connector
BO	Binector output
BOP	Basic operator panel
C	Commissioning
CB	Communication board
CCW	Counter-clockwise
CDS	Command data set
CI	Connector input
CM	Configuration management
CMD	Commando
CMM	Combimaster
CO	Connector output
CO/BO	Connector output / Binector output
COM	Common (terminal that is connected to NO or NC)
COM-Link	Communication link
CT	Commissining, ready to run
CT	Constant torque
CUT	Commissining, run, ready to run
CW	Clockwise
DA	Digital analog converter
DAC	Digital analog converter
DC	Direct current
DDS	Drive data set
DIN	Digital input
DIP	DIP switch
DOUT	Digital output
DS	Drive state
EEC	European Economic Community
EEPROM	Electrical erasable programmable read-only memory
ELCB	Earth leakage circuit breaker

EMC	Electro-magnetic compatibility
EMF	Electromotive force
EMI	Electro-magnetic interference
ESB	Equivalent circuit
FAQ	Frequently asked questions
FB	Function block
FCC	Flux current control
FCL	Fast current limit
FF	Fixed frequency
FFB	Free function block
FOC	Field orientated control
FSA	Frame size A
GSG	Getting started guide
GUI ID	Global unique identifier
HIW	Main actual value
HSW	Main setpoint
HTL	High-threshold logic
I/O	Input and output
IBN	Commissioning
IGBT	Insulated gate bipolar transistor
IND	Sub-index
JOG	Jog
KIB	Kinetic buffering
LCD	Liquid crystal display
LED	Light emitting diode
LGE	Length
MHB	Motor holding brake
MM4	MICROMASTER 4th. Generation
MOP	Motor potentiometer
NC	Normally closed
NO	Normally open
NPN	Negative positive negative
OPI	Operating instructions
PDS	Power drive system
PID	PID controller (proportional, integral, derivative)
PKE	Parameter ID
PKW	Parameter ID value
PLC	Programmable logic controller
PLI	Parameter list
PNP	Positive negative positive
POT	Potentiometer
PPO	Parameter process data object
PTC	Positive temperature coefficient
PWE	Parameter value
PWM	Pulse-width modulation
PX	Power extension
PZD	Process data
QC	Quick commissioning
RAM	Random-access memory

RCCB	Residual current circuit breaker
RCD	Residual current device
RFG	Ramp function generator
RFI	Radio-frequency interference
RPM	Revolutions per minute
SCL	Scaling
SDP	Status display panel
SLVC	Sensorless vector control
STW	Control word
STX	Start of text
SVM	Space vector modulation
TTL	Transistor-transistor logic
USS	Universal serial interface
VC	Vector control
Vdc	DC-link voltage
VT	Variable torque
ZSW	Status word
ZUSW	Additional setpoint

Suggestions and/or Corrections

To
Siemens AG
Automation & Drives Group
SD VM 4
P.O. Box 3269

D-91050 Erlangen
Federal Republic of Germany

Email:
documentation.sd@siemens.com

**Suggestions
Corrections**

For Publication/Manual:
MICROMASTER 430
Parameter List

User Documentation

From

Name: _____

Company/Service Department

Address: _____

Phone: _____ / _____

Fax: _____ / _____

Order number: 6SE6400-5BB00-0BP0

Date of Issue: 07/05

Should you come across any printing errors when reading this publication, please notify us on this sheet.

Suggestions for improvement are also welcome.

Siemens AG
Automation and Drives Group (A&D)
Standard Drives (SD) Division
Postfach 3269, D-91050 Erlangen
Federal Republic of Germany

© Siemens AG 2002, 2005
Subject to change without prior notice

Siemens Aktiengesellschaft

Order No.: 6SE6400-5AF00-0BP0

