

SIEMENS

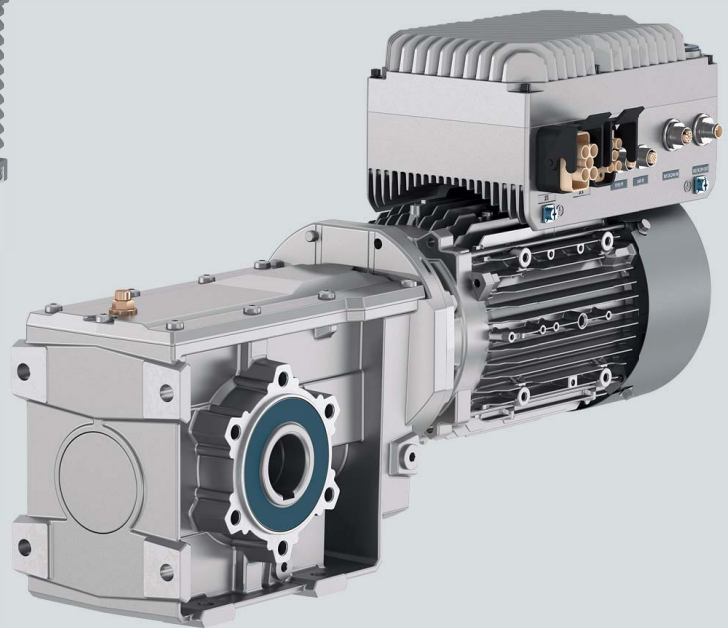
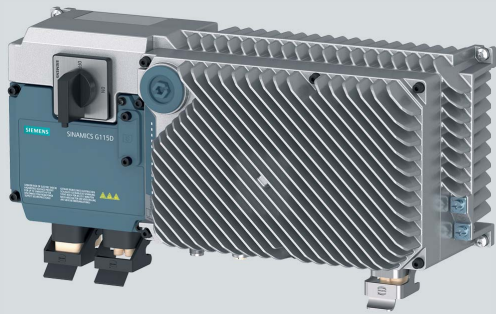

List Manual

SINAMICS

SINAMICS G115D

Edition

09/2021

www.siemens.com/drives

SIEMENS

SINAMICS

SINAMICS G115D

List Manual

Valid for

Control Unit

SINAMICS G115D

G115D I/O

G115D PN

G115D ASI

Firmware version

4.7 SP13

4.7 SP13

4.7 SP13

4.7 SP13

Fundamental safety instructions

1

Parameters

2

Function diagrams

3

Faults and alarms

4

Appendix



A

Index

Legal information

Warning concept

This Manual contains information which you must observe to ensure your own personal safety as well as to avoid material damage. The notices referring to your personal safety are highlighted in the manual by a safety alert symbol, notices referring only to equipment damage have no safety alert symbol. Depending on the hazard level, warnings are indicated in a descending order as follows:

 DANGER
indicates that death or serious injury will result if proper precautions are not taken.
 WARNING
indicates that death or serious injury could result if proper precautions are not taken.
 CAUTION
indicates that minor personal injury can result if proper precautions are not taken.
NOTICE
indicates that property damage can result if proper precautions are not taken.

If more than one level of danger is simultaneously applicable, the warning notice for the highest level is used. A notice warning of injury to persons with a safety alert symbol may also include a warning relating to property damage.

Qualified personnel

The product/system described in this documentation may only be operated by **personnel qualified** for the specific task in accordance with the relevant documentation for the specific task, in particular its warning notices and safety instructions. Qualified personnel are those who, based on their training and experience, are capable of identifying risks and avoiding potential hazards when working with these products/systems.

Proper use of Siemens products

Note the following:

 WARNING
Siemens products are only permitted to be used for the applications envisaged in the catalog and in the associated technical documentation. If third-party products and components are to be used, they must be recommended or approved by Siemens. These products can only function correctly and safely if they are transported, stored, set up, mounted, installed, commissioned, operated and maintained correctly. The permissible ambient conditions must be adhered to. Information in the associated documentation must be observed.

Trademarks

All names identified with ® are registered trademarks of Siemens AG. Any other names used in this publication may be trademarks whose use by third parties for their own purposes could violate the rights of the owner.

Disclaimer of liability

We have verified that the contents of this document correspond to the hardware and software described. Since variance cannot be precluded entirely, we cannot guarantee full consistency. The information given in this document is reviewed at regular intervals and any corrections that might be necessary are made in the subsequent editions.

Preface

SINAMICS documentation

The SINAMICS documentation is organized in the following categories:

- General documentation/catalogs
- Manufacturer/service documentation

Additional information

Information on the following topics is available under the link:

- Ordering documentation / overview of documentation
- Additional links to download documents
- Using documentation online (browse and search in manuals/information).

<http://www.siemens.com/motioncontrol/docu>

Please send any questions about the technical documentation (e. g. suggestions for improvement, corrections) to the following e-mail address:

docu.motioncontrol@siemens.com

My Documentation Manager

Information on how to produce individual contents for your own machine documentation based on Siemens contents is available under the link:

<http://www.siemens.com/mdm>

Training

Information about SITRAIN (Siemens Training on products, systems and solutions for automation) is available under the following link:

<http://www.siemens.com/sitrain>

FAQs

You can find Frequently Asked Questions in the Service&Support pages under Product Support:

<http://support.automation.siemens.com>

SINAMICS

You can find information on SINAMICS at:

<http://www.siemens.com/sinamics>

Target group

This documentation is intended for machine manufacturers, commissioning engineers, and service personnel who use the SINAMICS drive system.

Benefits

This documentation contains comprehensive information about parameters, function diagrams and faults and alarms required to commission and service the system.

This manual should be used in addition to the other manuals and tools provided for the product.

Standard scope

The scope of the functionality described in this document can differ from the scope of the functionality of the drive system that is actually supplied.

- Other functions not described in this documentation might be able to be executed in the drive system. This does not, however, represent an obligation to supply such functions with a new controller or when servicing.
- The documentation can also contain descriptions of functions that are not available in a particular product version of the drive system. The functionalities of the supplied drive system should only be taken from the ordering documentation.
- Extensions or changes made by the machine manufacturer must be documented by the machine manufacturer.

For reasons of clarity, this documentation does not contain all of the detailed information about all of the product types, This documentation cannot take into consideration every conceivable type of installation, operation and service/maintenance.

Search guides

The following tools are provided to help you locate information in this manual:

1. Table of contents
 - Table of contents for the complete manual (Page 9)
 - Table of contents for function diagrams (Page 492)
2. List of abbreviations (Page 795)
3. Index (Page 805)

Technical Support

Country-specific telephone numbers for technical support are provided at the following Internet address:

<http://www.siemens.com/automation/service&support>

EC Declaration of Conformity

The EC Declaration of Conformity for the EMC Directive can be found on the Internet at:

<https://support.industry.siemens.com/cs/products?dtp=Certificate&mf=ps&pnid=27867&lc=de-WW>

Alternatively, you can contact the Siemens office in your region in order to obtain the EC Declaration of Conformity.

Compliance with the General Data Protection Regulation

Siemens respects the principles of data protection, in particular the data minimization rules (privacy by design).

For this product, this means:

The product does not process neither store any person-related data, only technical function data (e.g. time stamps). If the user links these data with other data (e.g. shift plans) or if he stores person-related data on the same data medium (e.g. hard disk), thus personalizing these data, he has to ensure compliance with the applicable data protection stipulations.

Table of contents

1	Fundamental safety instructions	11
1.1	General safety instructions	12
1.2	Warranty and liability for application examples	12
1.3	Security information	13
2	Parameters	15
2.1	Overview of parameters.	16
2.1.1	Explanation of the parameter list	16
2.1.2	Number ranges of parameters.	26
2.2	List of parameters	29
2.3	Parameters for data sets	465
2.3.1	Command Data Sets (CDS).	465
2.3.2	Drive Data Sets (DDS).	467
2.4	BICO parameters (connectors/binectors).	476
2.4.1	Binector inputs (BI).	476
2.4.2	Connector inputs (CI).	478
2.4.3	Binector outputs (BO)	480
2.4.4	Connector outputs (CO).	481
2.4.5	Connector/binector outputs (CO/BO).	485
2.5	Parameters for write protection and know-how protection	487
2.5.1	Parameters with "WRITE_NO_LOCK"	487
2.5.2	Parameters with "KHP_WRITE_NO_LOCK"	487
2.5.3	Parameters with "KHP_ACTIVE_READ"	488
2.6	Quick commissioning (p0010 = 1)	489
3	Function diagrams	491
3.1	Table of contents	492
3.2	Explanations of the function diagrams	498
3.3	Input/output terminals, DIP switch	503
3.4	PROFenergy	511
3.5	Communication PROFIdrive (PROFINET), EtherNet/IP	514
3.6	Communication, fieldbus interface (AS-Interface)	534
3.7	Internal control/status words.	541
3.8	Brake control	561
3.9	Safety Integrated Basic Functions	563
3.10	Safety Integrated PROFIsafe.	569
3.11	Setpoint channel	572
3.12	Encoder evaluation	583

3.13	Vector control / U/f control	585
3.14	Technology functions.	616
3.15	Conveyor technology applications	619
3.16	Free function blocks.	632
3.17	Technology controller	653
3.18	Signals and monitoring functions	658
3.19	Diagnostics.	671
3.20	Data sets.	677
4	Faults and alarms	681
4.1	Overview of faults and alarms	682
4.1.1	General	682
4.1.2	Explanation of the list of faults and alarms	686
4.1.3	Number ranges of faults and alarms	691
4.2	List of faults and alarms	693
A	Appendix	791
A.1	ASCII table (characters that can be displayed)	792
A.2	List of abbreviations.	795
	Index	805

Fundamental safety instructions

Content

1.1	General safety instructions	12
1.2	Warranty and liability for application examples	12
1.3	Security information	13

1.1 General safety instructions

 WARNING
Danger to life if the safety instructions and residual risks are not observed
If the safety instructions and residual risks in the associated hardware documentation are not observed, accidents involving severe injuries or death can occur.
<ul style="list-style-type: none">• Observe the safety instructions given in the hardware documentation.• Consider the residual risks for the risk evaluation.

 WARNING
Malfunctions of the machine as a result of incorrect or changed parameter settings
As a result of incorrect or changed parameterization, machines can malfunction, which in turn can lead to injuries or death.
<ul style="list-style-type: none">• Protect the parameterization against unauthorized access.• Handle possible malfunctions by taking suitable measures, e.g. emergency stop or emergency off.

1.2 Warranty and liability for application examples

Application examples are not binding and do not claim to be complete regarding configuration, equipment or any eventuality which may arise. Application examples do not represent specific customer solutions, but are only intended to provide support for typical tasks.

As the user you yourself are responsible for ensuring that the products described are operated correctly. Application examples do not relieve you of your responsibility for safe handling when using, installing, operating and maintaining the equipment.

1.3 Security information

Siemens provides products and solutions with industrial security functions that support the secure operation of plants, systems, machines and networks.

In order to protect plants, systems, machines and networks against cyber threats, it is necessary to implement – and continuously maintain – a holistic, state-of-the-art industrial security concept. Siemens' products and solutions constitute one element of such a concept.

Customers are responsible for preventing unauthorized access to their plants, systems, machines and networks. Such systems, machines and components should only be connected to an enterprise network or the internet if and to the extent such a connection is necessary and only when appropriate security measures (e.g. firewalls and/or network segmentation) are in place.

For additional information on industrial security measures that can be implemented, please visit:

Industrial security (<https://www.siemens.com/industrialsecurity>)

Siemens' products and solutions undergo continuous development to make them more secure. Siemens strongly recommends that product updates are applied as soon as they are available and that the latest product versions are used. Use of product versions that are no longer supported, and failure to apply the latest updates may increase customer's exposure to cyber threats.

To stay informed about product updates, subscribe to the Siemens Industrial Security RSS Feed at:

Industrial security
(<https://new.siemens.com/global/en/products/services/cert.html#Subscriptions>).

Further information is provided on the Internet:

Industrial Security Configuration Manual
(<https://support.industry.siemens.com/cs/ww/en/view/108862708>)

WARNING

Unsafe operating states resulting from software manipulation

Software manipulations (e.g. viruses, trojans, malware or worms) can cause unsafe operating states in your system that may lead to death, serious injury, and property damage.

- Keep the software up to date.
- Incorporate the automation and drive components into a holistic, state-of-the-art industrial security concept for the installation or machine.
- Make sure that you include all installed products into the holistic industrial security concept.
- Protect files stored on exchangeable storage media from malicious software by with suitable protection measures, e.g. virus scanners.
- On completion of commissioning, check all security-related settings.

Parameters

2

Content

2.1	Overview of parameters	16
2.2	List of parameters	29
2.3	Parameters for data sets	465
2.4	BICO parameters (connectors/binectors)	476
2.5	Parameters for write protection and know-how protection	487
2.6	Quick commissioning (p0010 = 1)	489

2.1 Overview of parameters



2.1.1 Explanation of the parameter list

Basic structure of the parameter descriptions

The data in the following example have been chosen at random. The table below contains all the information that can be included in a parameter description. Some of the information is optional.

The "List of parameters (Page 29)" has the following layout:

----- **Start of example** -----

pxxxx[0...n]	BICO: Full parameter name / abbreviated name			
CU/PM variants	Access level: 3	Calculated: p0340 = 1	Data type: FloatingPoint32	
	Can be changed: C(x), U, T	Scaling: p2002	Dyn. index: CDS, p0170	
	Unit group: 6_2	Unit selection: p0505	Function diagram: 8070	
	Min	Max	Factory setting	
	0.00 [Nm]	10.00 [Nm]	0.00 [Nm]	
Description:	Text			
Values:	0: Name and meaning of value 0 1: Name and meaning of value 1 2: Name and meaning of value 2 etc.			
Recommendation:	Text			
Index:	[0] = Name and meaning of index 0 [1] = Name and meaning of index 1 [2] = Name and meaning of index 2 etc.			
Bit array:	Bit	Signal name	1 signal	0 signal
	00	Name and meaning of bit 0	Yes	No
	01	Name and meaning of bit 1	Yes	No
	02	Name and meaning of bit 2	Yes	No
		etc.		FP
				8060
				-
				8052
Dependency:	Text See also: pxxxx, rxxxx See also: Fxxxx, Axxxx			
Danger:	Warning:	Caution:	Safety notices with a warning triangle	
				
Notice:	Safety notice without a warning triangle			
Note:	Information that might be useful.			

----- **End of example** -----

The individual pieces of information are described in detail below.

pxxxx[0...n] Parameter number

The parameter number is made up of a "p" or "r", followed by the parameter number and the index or bit field (optional).

Examples of the representation in the parameter list:

- p... Adjustable parameters (read and write)
- r... Display parameters (read only)
- p0918 Adjustable parameter 918
- p2051[0...13] Adjustable parameter 2051, indices 0 to 13
- p1001[0...n] Adjustable parameter 1001, indices 0 to n (n = configurable)
- r0944 Display parameter 944
- r2129.0...15 Display parameter 2129 with bit field from bit 0 (smallest bit) to bit 15 (largest bit)

Other examples of notation in the documentation:

- p1070[1] Adjustable parameter 1070, index 1
- p2098[1].3 Adjustable parameter 2098, index 1 bit 3
- p0795.4 Adjustable parameter 795, bit 4

The following applies to adjustable parameters:

The parameter value as delivered is specified under "Factory setting" with the relevant unit in square brackets. The value can be adjusted within the range defined by "Min" and "Max".

The term "linked parameterization" is used in cases where changes to adjustable parameters affect the settings of other parameters.

Linked parameterization can occur, for example, as a result of the following actions and parameters:

- Setting the PROFIBUS telegram (BICO interconnection)
p0922
- Setting component lists
p0230, p0300, p0301, p0400
- Automatically calculating and pre-assigning
p0340, p3900
- Restoring the factory settings
p0970

The following applies to display parameters:

The fields "Min", "Max" and "Factory setting" are specified with a dash "-" and the relevant unit in square parentheses.

Note

The parameter list can contain parameters that are not visible in the expert lists of the particular commissioning software (e.g. parameters for trace functions).

BICO: Full parameter name/Abbreviated name

The following abbreviations can appear in front of the BICO parameter name:

- **BI:** Binector Input
This parameter is used for selecting the source of a digital signal.
- **BO:** Binector Output
This parameter is available as a digital signal for interconnection with other parameters.
- **CI:** Connector Input
This parameter is used for selecting the source of an "analog" signal.
- **CO:** Connector Output
This parameter is available as an "analog" signal for interconnection with other parameters.
- **CO/BO:** Connector/Binector Output
This parameter is available as an "analog" and digital signal for interconnection with other parameters.

Note

A BICO input (BI/CI) cannot be interconnected with just any BICO output (BO/CO, signal source). When interconnecting a BICO input using the commissioning software, only the corresponding possible signal sources are listed.

Function diagrams 1020 ... 1030 explain the symbols for BICO parameters and how to deal with BICO technology.

CU variants

Specifies the Control Unit (CU) for which the parameter is valid. If no CU is listed, then the parameter is valid for all variants.

The following information about "CU" can be displayed under the parameter number:

Table 2-1 Information in the "CU variants" field

CU variants	Meaning
All objects	All Control Units have this parameter.
CU_G115D_I/O	G115D without communication interface
CU_G115D_PN	G115D with PROFINET interface
CU_G115D_ASI	G115D with AS-Interface

Access level

Specifies the minimum access level required to be able to display and change the relevant parameter. The required access level can be set using p0003.

The system uses the following access levels:

- 1: Standard (not adjustable, included in p0003 = 3)
- 2: Extended (not adjustable, included in p0003 = 3)
- 3: Expert
- 4: Service

Parameters with this access level are password protected.

Note

Parameter p0003 is CU-specific (belongs to the Control Unit).

A higher access level will also include the functions of the lower levels.

Calculated

Specifies whether the parameter is influenced by automatic calculations.

p0340 determines which calculations are to be performed:

- p0340 = 1 includes the calculations from p0340 = 2, 3, 4, 5.
- p0340 = 2 calculates the motor parameters (p0350 ... p0360, p0625).
- p0340 = 3 includes the calculations from p0340 = 4, 5.
- p0340 = 4 only calculates the controller parameters.
- p0340 = 5 only calculates the controller limits.

Note

For p3900 > 0, p0340 = 1 is also called automatically.

After p1900 = 1, 2, p0340 = 3 is also called automatically.

Parameters with a reference to p0340 after "Calculated" depend on the Power Module being used and the motor. In this case, the values at "Factory setting" do not correspond to the actual values because these values are calculated during the commissioning. This also applies to the motor parameters.

Data type

The information on the data type can consist of the following two items (separated by a slash):

- First item
Data type of the parameter
- Second item (for binector or connector input only)
Data type of the signal source to be interconnected (binector-/connector output).

Parameters can have the following data types:

- Integer8 I8 8-bit integer number
- Integer16 I16 16-bit integer number
- Integer32 I32 32-bit integer number
- Unsigned8 U8 8 bits without sign
- Unsigned16 U16 16 bits without sign
- Unsigned32 U32 32 bits without sign
- FloatingPoint32 Float 32-bit floating point number

Depending on the data type of the BICO input parameter (signal sink) and BICO-output parameter (signal source), the following combinations are possible when creating BICO-interconnections:

Table 2-2 Possible combinations of BICO interconnections

BICO output parameter	BICO input parameter			
	CI parameter			BI parameter
	Unsigned32 / Integer16	Unsigned32 / Integer32	Unsigned32 / FloatingPoint32	Unsigned32 / Binary
CO: Unsigned8	x	x	–	–
CO: Unsigned16	x	x	–	–
CO: Unsigned32	x	x	–	–
CO: Integer16	x	x	r2050	–
CO: Integer32	x	x	r2060	–
CO: FloatingPoint32	x	x	x	–
BO: Unsigned8	–	–	–	x
BO: Unsigned16	–	–	–	x
BO: Unsigned32	–	–	–	x
BO: Integer16	–	–	–	x
BO: Integer32	–	–	–	x
BO: FloatingPoint32	–	–	–	–
Legend: x: x: BICO interconnection permitted –: –: BICO interconnection not permitted rxxxx: BICO interconnection is only permitted for the specified CO parameters				

Can be changed

The "-" sign indicates that the parameter can be changed in any object state and that the change will be effective immediately.

The information "C(x), T, U" ((x): optional) means that the parameter can be changed only in the specified drive unit state and that the change will not take effect until the unit switches to another state. One or more states are possible.

The following states are available:

- C(x) Commissioning C: Commissioning

Drive commissioning is in progress (p0010 > 0).

Pulses cannot be enabled.

The parameter can only be changed in the following drive commissioning settings (p0010 > 0):

- C: Can be changed for all settings p0010 > 0.
- C(x): Can only be changed for the settings p0010 = x.

A modified parameter value does not take effect until drive commissioning mode is exited with p0010 = 0.

- U Operation U: Run

Pulses are enabled.

- T Ready T: Ready to run

The pulses are not enabled and the status "C(x)" is not active.

Normalization

Specification of the reference variable with which a signal value is automatically converted for a BICO interconnection.

The following reference variables are available:

- p2000 ... p2007: Reference speed, reference voltage, etc.
- PERCENT: 1.0 = 100 %
- 4000H: 4000 hex = 100 % (word) or 4000 0000 hex = 100 % (double word)
- p0514: specific normalization
Refer to the description for p0514[0...9] and p0515[0...19] to p0524[0...19]

Dyn. index (dynamic index)

For parameters with a dynamic index [0...n], the following information is specified here:

- Data set (if available).
- Parameter for the number of indices (n = number - 1).

The following information can be contained in this field:

- "CDS, p0170" (Command Data Set, CDS count)

Example:

p1070[0] → main setpoint [command data set 0]

p1070[1] → main setpoint [command data set 1], etc.

- "DDS, p0180" (Drive Data Set, DDS count)

Data sets can only be created and deleted when p0010 = 15.

Note

Information on the data sets can be taken from the following references:

SINAMICS G115D Operating Instructions.

Unit group and unit selection

The standard unit of a parameter is specified in square parentheses after the values for "Min", "Max", and "Factory setting".

For parameters where the unit can be switched over, the specifications for "Unit group" and "Unit selection" determine the group to which this parameter belongs and with which parameter the unit can be switched over.

Example:

Unit group: 7_1, unit selection: p0505

The parameter belongs to unit group 7_1 and the unit can be switched over using p0505.

All the potential unit groups and possible unit selections are listed below.

Table 2-3 Unit group (p0100)

Unit group	Unit Choice for p0100 =			Reference variable for %
	0	1	2	
7_4	Nm	lbf ft	Nm	-
14_6	kW	hp	kW	-
25_1	kg m ²	lb ft ²	kg m ²	-
27_1	kg	lb	kg	-
28_1	Nm/A	lbf ft/A	Nm/A	-

Table 2-4 Unit group (p0505)

Unit group	Unit Choice for p0505 =				Reference variable for %
	1	2	3	4	
2_1	Hz	%	Hz	%	p2000
3_1	1 rpm	%	1 rpm	%	p2000
5_1	Vrms	%	Vrms	%	p2001
5_2	V	%	V	%	p2001
5_3	V	%	V	%	p2001
6_2	Arms	%	Arms	%	p2002
6_5	A	%	A	%	p2002
7_1	Nm	%	lbf ft	%	p2003
7_2	Nm	Nm	lbf ft	lbf ft	-
14_5	kW	%	hp	%	r2004
14_10	kW	kW	hp	hp	-
21_1	°C	°C	°F	°F	-
21_2	K	K	°F	°F	-
39_1	1/s ²	%	1/s ²	%	p2007

Table 2-5 Unit group (p0595)

Unit group	Unit Choice for p0595 =		Reference variable for %
	Value	Unit	
9_1	The values that can be set and the technological units are shown in p0595.		

Function diagram

The parameter is included in this function diagram. The structure of the parameter function and its relationship with other parameters is shown in the specified function diagram.

Parameter values

Min	Minimum value of the parameter [unit]
Max	Maximum value of the parameter [unit]
Factory setting	Value when delivered [unit] In the case of a binector/connector input, the signal source of the default BICO interconnection is specified. A non-indexed connector output is assigned the index [0]. A different value may be displayed for certain parameters (e.g. p1800) at the initial commissioning stage or when establishing the factory settings. Reason: The setting of these parameters is determined by the operating environment of the Control Unit (e.g. depending on device type, power unit).

Description

Explanation of the function of a parameter.

Values

Lists the possible values of a parameter.

Recommendation

Information about recommended settings.

Index

The name and meaning of each individual index is specified for indexed parameters.

The following applies to the values (Min, Max, Factory setting) of indexed adjustable parameters:

- Min, Max:
The adjustment range and unit apply to all indices.
- Factory setting:
When all indices have the same factory setting, index 0 is specified with the unit to represent all indices.
When the indices have different factory settings, they are all listed individually with the unit.

Bit field

For parameters with bit fields, the following information is provided about each bit:

- Bit number and signal name
- Meaning for signal states 0 and 1
- Function diagram (FP) (optional).

The signal is shown on this function diagram.

Dependency

Conditions that must be fulfilled in conjunction with this parameter. Also includes special effects that can occur between this parameter and others.

Where necessary, "Refer to:" indicates the following information:

- List of other relevant parameters to be considered.
- List of faults and alarms to be considered.

Safety guidelines

Important information that must be observed to avoid the risk of physical injury or material damage.

Information that must be observed to avoid any problems.

Information that the user may find useful.

Danger



The description of this safety notice can be found at the beginning of this manual, see "Legal information (Page 4)".

Warning



The description of this safety notice can be found at the beginning of this manual, see "Legal information (Page 4)".

Caution



The description of this safety notice can be found at the beginning of this manual, see "Legal information (Page 4)".

Notice

The description of this safety notice can be found at the beginning of this manual, see "Legal information (Page 4)".

Note

Information that the user may find useful.

2.1.2 Number ranges of parameters

Note

The following number ranges represent an overview for all the parameters available for the SINAMICS drive family.

The parameters for the product described in this List Manual are described in detail in "List of parameters (Page 29)".

Parameters are grouped into the following number ranges:

Table 2-6 Number ranges for SINAMICS

Range		Description
From	To	
0000	0099	Display and operation
0100	0199	Commissioning
0200	0299	Power section
0300	0399	Motor
0400	0499	Encoder
0500	0599	Technology and units, motor-specific data, probes
0600	0699	Thermal monitoring, maximum current, operating hours, motor data, central probe
0700	0799	Control Unit terminals, measuring sockets
0800	0839	CDS, DDS data sets, motor changeover
0840	0879	Sequence control (e.g. signal source for ON/OFF1)
0880	0899	ESR, parking, control and status words
0900	0999	PROFIBUS/PROFIdrive
1000	1199	Setpoint channel (e.g. ramp-function generator)
1200	1299	Functions (e.g. motor holding brake)
1300	1399	U/f control
1400	1799	Closed-loop control
1800	1899	Gating unit
1900	1999	Power unit and motor identification
2000	2009	Reference values
2010	2099	Communication (fieldbus)
2100	2139	Faults and alarms
2140	2199	Signals and monitoring
2200	2359	Technology controller
2360	2399	Staging, hibernation
2500	2699	Position control (LR) and basic positioning (EPOS)
2700	2719	Reference values, display

Table 2-6 Number ranges for SINAMICS, continued

Range		Description
From	To	
2720	2729	Load gearbox
2800	2819	Logic operations
2900	2930	Fixed values (e. g. percentage, torque)
3000	3099	Motor identification results
3100	3109	Real-time clock (RTC)
3110	3199	Faults and alarms
3200	3299	Signals and monitoring
3400	3659	Infeed closed-loop control
3660	3699	Voltage Sensing Module (VSM), Braking Module internal
3700	3779	Advanced Positioning Control (APC)
3780	3819	Synchronization
3820	3849	Friction characteristic
3850	3899	Functions (e. g. long stator)
3900	3999	Management
4000	4599	Terminal Board, Terminal Module (e. g. TB30, TM31)
4600	4699	Sensor Module
4700	4799	Trace
4800	4849	Function generator
4950	4999	OA application
5000	5169	Spindle diagnostics
5200	5230	Current setpoint filter 5 ... 10 (r0108.21)
5400	5499	System droop control (e. g. shaft generator)
5500	5599	Dynamic grid support (solar)
5600	5614	PROFenergy
5900	6999	SINAMICS GM/SM/GL/SL
7000	7499	Parallel connection of power units
7500	7599	SINAMICS SH/GH
7700	7729	External messages
7770	7789	NVRAM, system parameters
7800	7839	EEPROM read/write parameters
7840	8399	Internal system parameters
8400	8449	Real-time clock (RTC)
8500	8599	Data and macro management
8600	8799	CAN bus
8800	8899	Communication Board Ethernet (CBE), PROFIdrive

Table 2-6 Number ranges for SINAMICS, continued

Range		Description
From	To	
8900	8999	Industrial Ethernet, PROFINET, CBE20
9000	9299	topology
9300	9399	Safety Integrated
9400	9499	Parameter consistency and storage
9500	9899	Safety Integrated
9900	9949	topology
9950	9999	Diagnostics, internal
10000	10199	Safety Integrated
11000	11299	Free technology controller 0, 1, 2
20000	20999	Free function blocks (FBLOCKS)
21000	25999	Drive Control Chart (DCC)
50000	53999	SINAMICS DC MASTER (closed-loop DC current control)
61000	61001	PROFINET

2.2 List of parameters

Product: G115D, Version: 4715218, Language: eng
Objects: G115D I/O, G115D PN, G115D ASI

r0002	Drive operating display / Drv op_display		
Access level: 2	Calculated: -	Data type: Integer16	
Can be changed: -	Scaling: -	Dyn. index: -	
Unit group: -	Unit selection: -	Func. diagram: -	
Min	Max	Factory setting	
0	200	-	
Description:	Operating display for the drive.		
Value:	0: Operation - everything enabled 10: Operation - set "enable setpoint" = "1" (p1142) 12: Operation - RFG frozen, set "RFG start" = "1" (p1141) 13: Operation - set "enable RFG" = "1" (p1140) 14: Operation - MotID, excitation running 15: Operation - open brake (p1215) 16: Operation - withdraw braking with OFF1 using "ON/OFF1" = "1" 17: Operation - braking with OFF3 can only be interrupted with OFF2 18: Operation - brake on fault, remove fault, acknowledge 19: Operation - DC braking active (p1230, p1231) 21: Ready for operation - set "Enable operation" = "1" (p0852) 22: Ready for operation - de-magnetizing running (p0347) 31: Ready for switching on - set "ON/OFF1" = "0/1" (p0840) 35: Switching on inhibited - carry out first commissioning (p0010) 41: Switching on inhibited - set "ON/OFF1" = "0" (p0840) 42: Switching on inhibited - set "OC/OFF2" = "1" (p0844, p0845) 43: Switching on inhibited - set "OC/OFF3" = "1" (p0848, p0849) 44: Switching on inhibited - supply STO terminal w/ 24 V (hardware) 45: Switching on inhibited - rectify fault, acknowledge fault, STO 46: Switching on inhibited - exit commissioning mode (p0010) 70: Initialization 200: Wait for booting/partial booting		
Dependency:	Refer to: r0046		
Notice:	For several missing enable signals, the corresponding value with the highest number is displayed.		
Note:	OC: Operating condition RFG: Ramp-function generator COMM: Commissioning MotID: Motor data identification		

p0003	Access level / Acc_level		
Access level: 1	Calculated: -	Data type: Integer16	
Can be changed: C, U, T	Scaling: -	Dyn. index: -	
Unit group: -	Unit selection: -	Func. diagram: -	
Min	Max	Factory setting	
3	4	3	
Description:	Sets the access level to read and write parameters.		
Value:	3: Expert 4: Service		
Note:	A higher set access level also includes the lower one. Access level 3 (experts): Expert know-how is required for these parameters (e.g. BICO parameterization). Access level 4 (service): For these parameters, it is necessary that authorized service personnel enter the appropriate password (p3950).		

p0010	Drive commissioning parameter filter / Drv comm. par_filt		
	Access level: 1	Calculated: -	Data type: Integer16
	Can be changed: C(1), T	Scaling: -	Dyn. index: -
	Unit group: -	Unit selection: -	Func. diagram: 2800, 2818
	Min	Max	Factory setting
	0	95	1
Description:	Sets the parameter filter to commission a drive. Setting this parameter filters out the parameters that can be written into in the various commissioning steps.		
Value:	0: Ready 1: Quick commissioning 2: Power unit commissioning 3: Motor commissioning 4: Encoder commissioning 5: Technological application/units 15: Data sets 29: Only Siemens internal 30: Parameter reset 39: Only Siemens internal 49: Only Siemens internal 95: Safety Integrated commissioning		
Note:	The drive can only be switched on outside the drive commissioning (inverter enable). To realize this, this parameter must be set to 0. By setting p3900 to a value other than 0, the quick commissioning is completed, and this parameter is automatically reset to 0. Procedure for "Reset parameter": Set p0010 to 30 and p0970 to 1.		

p0015	Macro drive unit / Macro drv unit		
G115D ASI	Access level: 1	Calculated: -	Data type: Unsigned32
	Can be changed: C, C(1)	Scaling: -	Dyn. index: -
	Unit group: -	Unit selection: -	Func. diagram: -
	Min	Max	Factory setting
	0	999999	30
Description:	Runs the corresponding macro files.		
Notice:	After the value has been modified, no further parameter modifications can be made and the status is shown in r3996. Modifications can be made again when r3996 = 0. When executing a specific macro, the corresponding programmed settings are made and become active.		
Note:	Macros available as standard are described in the technical documentation of the particular product.		

p0015	Macro drive unit / Macro drv unit		
G115D I/O	Access level: 1	Calculated: -	Data type: Unsigned32
	Can be changed: C, C(1)	Scaling: -	Dyn. index: -
	Unit group: -	Unit selection: -	Func. diagram: -
	Min	Max	Factory setting
	0	999999	65
Description:	Runs the corresponding macro files.		
Notice:	After the value has been modified, no further parameter modifications can be made and the status is shown in r3996. Modifications can be made again when r3996 = 0. When executing a specific macro, the corresponding programmed settings are made and become active.		
Note:	Macros available as standard are described in the technical documentation of the particular product.		

p0015	Macro drive unit / Macro drv unit		
G115D PN	Access level: 1	Calculated: -	Data type: Unsigned32
	Can be changed: C, C(1)	Scaling: -	Dyn. index: -
	Unit group: -	Unit selection: -	Func. diagram: -
	Min	Max	Factory setting
	0	999999	67
Description:	Runs the corresponding macro files.		
Notice:	After the value has been modified, no further parameter modifications can be made and the status is shown in r3996. Modifications can be made again when r3996 = 0.		
	When executing a specific macro, the corresponding programmed settings are made and become active.		
Note:	Macros available as standard are described in the technical documentation of the particular product.		
r0018	Control Unit firmware version / Firmware version		
	Access level: 3	Calculated: -	Data type: Unsigned32
	Can be changed: -	Scaling: -	Dyn. index: -
	Unit group: -	Unit selection: -	Func. diagram: -
	Min	Max	Factory setting
	0	4294967295	-
Description:	Displays the firmware version of the Control Unit.		
Dependency:	Refer to: r0197, r0198		
Note:	Example: The value 1010100 should be interpreted as V01.01.01.00.		
r0020	Speed setpoint smoothed / Speed setpoint		
	Access level: 2	Calculated: -	Data type: FloatingPoint32
	Can be changed: -	Scaling: p2000	Dyn. index: -
	Unit group: 3_1	Unit selection: p0505	Func. diagram: 5020, 6799
	Min	Max	Factory setting
	- [rpm]	- [rpm]	- [rpm]
Description:	Displays the currently smoothed speed setpoint at the input of the speed controller or <i>U/f</i> characteristic (after the interpolator).		
Dependency:	Refer to: r0060		
Note:	Smoothing time constant = 100 ms The signal is not suitable as a process quantity and may only be used as a display quantity. The speed setpoint is available smoothed (r0020) and unsmoothed (r0060).		
r0021	CO: Actual speed smoothed / Actual speed		
	Access level: 2	Calculated: -	Data type: FloatingPoint32
	Can be changed: -	Scaling: p2000	Dyn. index: -
	Unit group: 3_1	Unit selection: p0505	Func. diagram: 6799
	Min	Max	Factory setting
	- [rpm]	- [rpm]	- [rpm]
Description:	Display and connector output for the calculated and smoothed rotor speed. Frequency components from the slip compensation (for induction motors) are not included.		
Dependency:	Refer to: r0022, r0063		
Note:	Smoothing time constant = 100 ms The signal is not suitable as a process quantity and may only be used as a display quantity. The speed actual value is available smoothed (r0021, r0022) and unsmoothed (r0063).		

r0022	Actual speed rpm smoothed / Actual speed		
	Access level: 3	Calculated: -	Data type: FloatingPoint32
	Can be changed: -	Scaling: p2000	Dyn. index: -
	Unit group: -	Unit selection: -	Func. diagram: 6799
	Min	Max	Factory setting
	- [rpm]	- [rpm]	- [rpm]
Description:	Displays the calculated and smoothed rotor speed. Frequency components from the slip compensation (for induction motors) are not included. r0022 is identical to r0021, however, it always has units of rpm and contrary to r0021 cannot be changed over.		
Dependency:	Refer to: r0021, r0063		
Note:	Smoothing time constant = 100 ms The signal is not suitable as a process quantity and may only be used as a display quantity. The speed actual value is available smoothed (r0021, r0022) and unsmoothed (r0063).		
r0024	Output frequency smoothed / Output frequency		
	Access level: 3	Calculated: -	Data type: FloatingPoint32
	Can be changed: -	Scaling: p2000	Dyn. index: -
	Unit group: -	Unit selection: -	Func. diagram: 6300, 6799
	Min	Max	Factory setting
	- [Hz]	- [Hz]	- [Hz]
Description:	Displays the smoothed output frequency. Frequency components from the slip compensation (for induction motors) are included.		
Dependency:	Refer to: r0066		
Note:	Smoothing time constant = 100 ms The signal is not suitable as a process quantity and may only be used as a display quantity. The output frequency is available smoothed (r0024) and unsmoothed (r0066).		
r0025	CO: Output voltage smoothed / Output voltage		
	Access level: 2	Calculated: -	Data type: FloatingPoint32
	Can be changed: -	Scaling: p2001	Dyn. index: -
	Unit group: -	Unit selection: -	Func. diagram: 5730, 6300, 6799
	Min	Max	Factory setting
	- [Vrms]	- [Vrms]	- [Vrms]
Description:	Displays the smoothed output voltage of the power unit.		
Dependency:	Refer to: r0072		
Note:	Smoothing time constant = 100 ms The signal is not suitable as a process quantity and may only be used as a display quantity. The output voltage is available smoothed (r0025) and unsmoothed (r0072).		
r0026	CO: DC link voltage smoothed / DC link voltage		
	Access level: 2	Calculated: -	Data type: FloatingPoint32
	Can be changed: -	Scaling: p2001	Dyn. index: -
	Unit group: -	Unit selection: -	Func. diagram: 6799
	Min	Max	Factory setting
	- [V]	- [V]	- [V]
Description:	Displays the smoothed actual value of the DC link voltage.		
Dependency:	Refer to: r0070		
Notice:	When measuring a DC link voltage < 200 V, for the Power Module a valid measured value is not supplied. In this case, when an external 24 V power supply is connected, a value of approx. 24 V is displayed in the display parameter.		

Note: Smoothing time constant = 100 ms
The signal is not suitable as a process quantity and may only be used as a display quantity.
The DC link voltage is available smoothed (r0026) and unsmoothed (r0070).
r0026 sets itself to the lower value of the pulsating DC link voltage.

r0027	CO: Absolute actual current smoothed / Motor current		
	Access level: 2	Calculated: -	Data type: FloatingPoint32
	Can be changed: -	Scaling: p2002	Dyn. index: -
	Unit group: -	Unit selection: -	Func. diagram: 6799
	Min	Max	Factory setting
	- [Arms]	- [Arms]	- [Arms]

Description: Displays the smoothed absolute actual current value.

Dependency: Refer to: r0068

Notice: This smoothed signal is not suitable for diagnostics or evaluation of dynamic operations. In this case, the unsmoothed value should be used.

Note: Smoothing time constant = 300 ms
The signal is not suitable as a process quantity and may only be used as a display quantity.
The absolute current actual value is available smoothed (r0027) and unsmoothed (r0068).

r0028	Modulation depth smoothed / Mod_depth smth		
	Access level: 4	Calculated: -	Data type: FloatingPoint32
	Can be changed: -	Scaling: p2002	Dyn. index: -
	Unit group: -	Unit selection: -	Func. diagram: 6799
	Min	Max	Factory setting
	- [%]	- [%]	- [%]

Description: Displays the smoothed actual value of the modulation depth.

Dependency: Refer to: r0074

Note: Smoothing time constant = 100 ms
The signal is not suitable as a process quantity and may only be used as a display quantity.
The modulation depth is available smoothed (r0028) and unsmoothed (r0074).

r0029	Current actual value field-generating smoothed / Id_act smooth		
	Access level: 4	Calculated: -	Data type: FloatingPoint32
	Can be changed: -	Scaling: p2002	Dyn. index: -
	Unit group: -	Unit selection: -	Func. diagram: 6799
	Min	Max	Factory setting
	- [Arms]	- [Arms]	- [Arms]

Description: Displays the smoothed field-generating actual current.

Dependency: Refer to: r0076

Note: Smoothing time constant = 300 ms
The signal is not suitable as a process quantity and may only be used as a display quantity.
The field-generating current actual value is available smoothed (r0029) and unsmoothed (r0076).

r0030	Current actual value torque-generating smoothed / Iq_act smooth		
	Access level: 4	Calculated: -	Data type: FloatingPoint32
	Can be changed: -	Scaling: p2002	Dyn. index: -
	Unit group: -	Unit selection: -	Func. diagram: 6799
	Min	Max	Factory setting
	- [Arms]	- [Arms]	- [Arms]

Description: Displays the smoothed torque-generating actual current.

Dependency: Refer to: r0078

Note: Smoothing time constant = 300 ms
The signal is not suitable as a process quantity and may only be used as a display quantity.
The torque-generating current actual value is available smoothed (r0030) and unsmoothed (r0078).

r0031	Actual torque smoothed / Actual torque		
	Access level: 2	Calculated: -	Data type: FloatingPoint32
	Can be changed: -	Scaling: p2003	Dyn. index: -
	Unit group: 7_1	Unit selection: p0505	Func. diagram: 5730, 6799
	Min	Max	Factory setting
	- [Nm]	- [Nm]	- [Nm]
Description:	Displays the smoothed torque actual value.		
Dependency:	Refer to: r0080		
Note:	Smoothing time constant = 100 ms The signal is not suitable as a process quantity and may only be used as a display quantity. The torque actual value is available smoothed (r0031) and unsmoothed (r0080).		
r0032	CO: Active power actual value smoothed / Power		
	Access level: 2	Calculated: -	Data type: FloatingPoint32
	Can be changed: -	Scaling: r2004	Dyn. index: -
	Unit group: 14_10	Unit selection: p0505	Func. diagram: 6799
	Min	Max	Factory setting
	- [kW]	- [kW]	- [kW]
Description:	Displays the smoothed actual value of the active power.		
Dependency:	Refer to: r0082		
Notice:	This smoothed signal is not suitable for diagnostics or evaluation of dynamic operations. In this case, the unsmoothed value should be used.		
Note:	Power delivered at the motor shaft. The active power is available smoothed (r0032 with 100 ms) and unsmoothed (r0082).		
r0033	Torque utilization smoothed / M_util smooth		
	Access level: 4	Calculated: -	Data type: FloatingPoint32
	Can be changed: -	Scaling: PERCENT	Dyn. index: -
	Unit group: -	Unit selection: -	Func. diagram: 8012
	Min	Max	Factory setting
	- [%]	- [%]	- [%]
Description:	Displays the smoothed torque utilization as a percentage. The torque utilization is obtained from the required smoothed torque in reference to the torque limit, scaled using p2196.		
Dependency:	This parameter is only available for vector control. For U/f control r0033 = 0 %.		
Note:	Smoothing time constant = 100 ms The signal is not suitable as a process quantity and may only be used as a display quantity. The torque utilization is available smoothed (r0033) and unsmoothed (r0081). For M_set total (r0079) > 0, the following applies: - Required torque = M_set total - Actual torque limit = M_max upper effective (r1538) For M_set total (r0079) <= 0, the following applies: - Required torque = - M_set total - Actual torque limit = - M_max lower effective (r1539) For the actual torque limit = 0, the following applies: r0033 = 100 % For the actual torque limit < 0, the following applies: r0033 = 0 %		

r0034	CO: Motor utilization thermal / Mot_util therm		
	Access level: 2	Calculated: -	Data type: FloatingPoint32
	Can be changed: -	Scaling: PERCENT	Dyn. index: -
	Unit group: -	Unit selection: -	Func. diagram: 8017
	Min	Max	Factory setting
	- [%]	- [%]	- [%]
Description:	Display and connector output for the motor utilization from motor temperature model 1 (I2t). For firmware version < 4.7 SP6 or p0612.12 = 0: - $r0034 = (\text{motor model temperature} - 40 \text{ K}) / (\text{p0605} - 40 \text{ K}) * 100 \%$ From firmware version 4.7 SP6 and p0612.12 = 1: - $r0034 = (\text{motor model temperature} - \text{p0613}) / (\text{p0605} - \text{p0613}) * 100 \%$		
Dependency:	The thermal motor utilization is only determined when the motor temperature model 1 (I2t) is activated. The following conditions are a prerequisite for additional information. - a temperature sensor has not been parameterized (p0600, p0601). - the current corresponds to the stall current (p0318). - speed $n > 1$ [rpm]. For firmware version < 4.7 SP6 or p0612.12 = 0, the following applies: - the temperature model operates with an ambient temperature of 20 °C. A motor utilization of 100% is displayed ($r0034 = 100 \%$) when the following conditions are permanently fulfilled: - the ambient temperature is 40 °C (model 1: p0625 = 40 °C, model 3: p0613 = 40 °C). From firmware version 4.7 SP6 and p0612.12 = 1, the following applies: - the ambient temperature can be adapted to the conditions using p0613. Refer to: p0605, p0611, p0612, p0613, p0627, r0632 Refer to: F07011, A07012		
Notice:	After the drive is switched on, the system starts to determine the motor temperature with an assumed model value. This means that the value for the motor utilization is only valid after a stabilization time.		
Note:	Smoothing time constant = 100 ms The signal is not suitable as a process quantity and may only be used as a display quantity. For $r0034 = -200.0 \%$, the following applies: The value is invalid (e.g. the motor temperature model is not activated or has been incorrectly parameterized).		

r0035	CO: Motor temperature / Mot temp		
	Access level: 2	Calculated: -	Data type: FloatingPoint32
	Can be changed: -	Scaling: p2006	Dyn. index: -
	Unit group: 21_1	Unit selection: p0505	Func. diagram: 8016, 8017
	Min	Max	Factory setting
	- [°C]	- [°C]	- [°C]
Description:	Display and connector output for the actual temperature in the motor.		
Note:	For $r0035$ not equal to -200.0 °C, the following applies: - this temperature display is valid. - a KTY/PT1000 temperature sensor is connected. - the thermal model for the induction motor is activated (p0612 bit 1 = 1 and temperature sensor deactivated: p0600 = 0 or p0601 = 0). For $r0035$ equal to -200.0 °C, the following applies: - this temperature display is not valid (temperature sensor error). - a PTC sensor or bimetallic NC contact is connected. - the temperature sensor of the synchronous motor is deactivated (p0600 = 0 or p0601 = 0).		

r0036	CO: Power unit overload I2t / PM overload I2t		
	Access level: 3	Calculated: -	Data type: FloatingPoint32
	Can be changed: -	Scaling: PERCENT	Dyn. index: -
	Unit group: -	Unit selection: -	Func. diagram: 8021
	Min	Max	Factory setting
	- [%]	- [%]	- [%]
Description:	<p>Displays the power unit overload determined using the I2t calculation.</p> <p>A current reference value is defined for the I2t monitoring of the power unit. It represents the current that can be conducted by the power unit without any influence of the switching losses (e.g. the continuously permissible current of the capacitors, inductances, busbars, etc.).</p> <p>If the I2t reference current of the power unit is not exceeded, then an overload (0 %) is not displayed.</p> <p>In the other case, the degree of thermal overload is calculated, whereby 100% results in a trip.</p>		
Dependency:	<p>Refer to: p0290, p0294</p> <p>Refer to: F30005</p>		

r0037[0...19]	CO: Power unit temperatures / PM temperatures		
	Access level: 3	Calculated: -	Data type: FloatingPoint32
	Can be changed: -	Scaling: p2006	Dyn. index: -
	Unit group: 21_1	Unit selection: p0505	Func. diagram: 8021
	Min	Max	Factory setting
	- [°C]	- [°C]	- [°C]
Description:	<p>Display and connector output for the temperature in the power unit.</p>		
Index:	<p>[0] = Inverter maximum value [1] = Depletion layer maximum value [2] = Rectifier maximum value [3] = Air intake [4] = Interior of power unit [5] = Inverter 1 [6] = Inverter 2 [7...10] = Reserved [11] = Rectifier 1 [12] = Reserved [13] = Depletion layer 1 [14] = Depletion layer 2 [15] = Depletion layer 3 [16] = Depletion layer 4 [17] = Depletion layer 5 [18] = Depletion layer 6 [19] = Reserved</p>		
Notice:	<p>Only for internal Siemens troubleshooting.</p>		
Note:	<p>The value of -200 indicates that there is no measuring signal.</p> <p>r0037[0]: Maximum value of the inverter temperatures (r0037[5...10]). r0037[1]: Maximum value of the depletion layer temperatures (r0037[13...18]). r0037[2]: Maximum value of the rectifier temperatures (r0037[11...12]).</p> <p>The maximum value is the temperature of the hottest inverter, depletion layer, or rectifier. r0037[2, 3, 6, 11, 14...18] is only relevant for chassis power units.</p> <p>In the case of a fault, the particular shutdown threshold depends on the power unit, and cannot be read out.</p>		

r0038	Power factor smoothed / Cos phi smooth		
	Access level: 4	Calculated: -	Data type: FloatingPoint32
	Can be changed: -	Scaling: -	Dyn. index: -
	Unit group: -	Unit selection: -	Func. diagram: 6799
	Min	Max	Factory setting
	-	-	-
Description:	<p>Displays the smoothed actual power factor. This refers to the electrical power of the basic fundamental signals at the converter output terminals.</p>		

Notice: For infeed units, the following applies:
For active powers < 25 % of the rated power, this does not provide any useful information.

Note: Smoothing time constant = 300 ms
The signal is not suitable as a process quantity and may only be used as a display quantity.

r0039[0...2] CO: Energy display / Energy display

Access level: 2	Calculated: -	Data type: FloatingPoint32
Can be changed: -	Scaling: -	Dyn. index: -
Unit group: -	Unit selection: -	Func. diagram: -
Min	Max	Factory setting
- [kWh]	- [kWh]	- [kWh]

Description: Display and connector output for the energy values at the output terminals of the power unit.

Recommendation: r0042 should be used as process energy display.
Parameter r0039 supplies floating-point values in Ws as signal source.

Index: [0] = Energy balance (sum)
[1] = Energy drawn
[2] = Energy fed back

Dependency: Refer to: p0040

Note: For index [0]:
Difference between the energy drawn and energy that is fed back.

p0040 Reset energy consumption display / Energy usage reset

Access level: 3	Calculated: -	Data type: Unsigned8
Can be changed: U, T	Scaling: -	Dyn. index: -
Unit group: -	Unit selection: -	Func. diagram: -
Min	Max	Factory setting
0	1	0

Description: Setting to reset the display in r0039 and r0041.
Procedure:
Set p0040 = 0 --> 1
The displays are reset and the parameter is automatically set to zero.

Dependency: Refer to: r0039

Note: When this display is reset (p0040), then the process energy display (r0042) is also reset.

r0041 Energy consumption saved / Energy cons saved

Access level: 2	Calculated: -	Data type: FloatingPoint32
Can be changed: -	Scaling: -	Dyn. index: -
Unit group: -	Unit selection: -	Func. diagram: -
Min	Max	Factory setting
- [kWh]	- [kWh]	- [kWh]

Description: Displays the saved energy referred to 100 operating hours.

Dependency: Refer to: p0040

Note: This display is used for a fluid-flow machine.
The flow characteristic is entered into p3320 ... p3329.
For an operating time of below 100 hours, the display is interpolated up to 100 hours.

r0042[0...2] CO: Process energy display / Proc energy disp

Access level: 2	Calculated: -	Data type: Integer32
Can be changed: -	Scaling: -	Dyn. index: -
Unit group: -	Unit selection: -	Func. diagram: -
Min	Max	Factory setting
- [Wh]	- [Wh]	- [Wh]

Description: Display and connector output for the energy values at the output terminals of the power unit.

2 Parameters

2.2 List of parameters

Index: [0] = Energy balance (sum)
 [1] = Energy drawn
 [2] = Energy fed back

Dependency: Refer to: p0043

Note: The signal can be displayed as process variable (scaling: 1 = 1 Wh).
 This is enabled in p0043.
 The display is also reset with p0040 = 1.
 If an enable is present in r0043 when the Control Unit powers up, then the value from r0039 is transferred into r0042.
 As r0039 serves as a reference signal for r0042, due to format reasons, the process energy display can only process values of r0039 up to 2147483 kWh. r0039 should also be reset using this value.

p0043	BI: Enable energy usage display / Enab energy usage		
	Access level: 2	Calculated: -	Data type: U32 / Binary
	Can be changed: U, T	Scaling: -	Dyn. index: -
	Unit group: -	Unit selection: -	Func. diagram: -
	Min	Max	Factory setting
	-	-	0

Description: Sets the signal source to enable/reset the process energy display in r0042.

BI: p0043 = 1 signal:

The process energy display is enabled in r0042.

Dependency: Refer to: r0042

p0045	Display values smoothing time constant / Disp_val T_smooth		
	Access level: 3	Calculated: -	Data type: FloatingPoint32
	Can be changed: U, T	Scaling: -	Dyn. index: -
	Unit group: -	Unit selection: -	Func. diagram: 6714, 8012
	Min	Max	Factory setting
	0.00 [ms]	10000.00 [ms]	4.00 [ms]

Description: Sets the smoothing time constant for the following display values:
 r0063[1], r0068[1], r0080[1], r0082[1].

r0046.0...31	CO/BO: Missing enable signal / Missing enable sig		
	Access level: 1	Calculated: -	Data type: Unsigned32
	Can be changed: -	Scaling: -	Dyn. index: -
	Unit group: -	Unit selection: -	Func. diagram: 2634
	Min	Max	Factory setting
	-	-	-

Description: Display and BICO output for missing enable signals that are preventing the closed-loop drive control from being commissioned.

Bit field:	Bit	Signal name	1 signal	0 signal	FP
	00	OFF1 enable missing	Yes	No	7954
	01	OFF2 enable missing	Yes	No	-
	02	OFF3 enable missing	Yes	No	-
	03	Operation enable missing	Yes	No	-
	04	DC braking enable missing	Yes	No	-
	08	Safety enable missing	Yes	No	-
	10	Ramp-function generator enable missing	Yes	No	-
	11	Ramp-function generator start missing	Yes	No	-
	12	Setpoint enable missing	Yes	No	-
	15	QuickStop enable missing	Yes	No	-
	16	OFF1 enable internal missing	Yes	No	-

17	OFF2 enable internal missing	Yes	No	-
18	OFF3 enable internal missing	Yes	No	-
19	Pulse enable internal missing	Yes	No	-
20	DC braking internal enable missing	Yes	No	-
21	Power unit enable missing	Yes	No	-
26	Drive inactive or not operational	Yes	No	-
27	De-magnetizing not completed	Yes	No	-
28	Brake open missing	Yes	No	-
30	Speed controller inhibited	Yes	No	-
31	Jog setpoint active	Yes	No	-

Dependency: Refer to: r0002

- Note:** The value r0046 = 0 indicates that all enable signals for this drive are present.
- Bit 00 = 1 (enable signal missing), if:
- the signal source in p0840 is a 0 signal.
 - there is a "switching on inhibited".
- Bit 01 = 1 (enable signal missing), if:
- the signal source in p0844 or p0845 is a 0 signal.
- Bit 02 = 1 (enable signal missing), if:
- the signal source in p0848 or p0849 is a 0 signal.
- Bit 03 = 1 (enable signal missing), if:
- the signal source in p0852 is a 0 signal.
- Bit 04 = 1 (DC brake active) when:
- the signal source in p1230 has a 1 signal.
- Bit 08 = 1 (enable signal missing), if:
- safety functions have been enabled and STO is active.
 - STO is selected via onboard terminals or PROFIsafe.
 - a safety-relevant signal is present with STOP A response.
- Bit 10 = 1 (enable signal missing), if:
- the signal source in p1140 is a 0 signal.
- Bit 11 = 1 (enable signal missing) if the speed setpoint is frozen, because:
- the signal source in p1141 is a 0 signal.
 - the speed setpoint is entered from jogging and the two signal sources for jogging, bit 0 (p1055) and bit 1 (p1056) have a 1 signal.
- Bit 12 = 1 (enable signal missing), if:
- the signal source in p1142 is a 0 signal.
- Bit 16 = 1 (enable signal missing), if:
- there is an OFF1 fault response. The system is only enabled if the fault is removed and was acknowledged and the "switching on inhibited" withdrawn with OFF1 = 0.
- Bit 17 = 1 (enable signal missing), if:
- commissioning mode is selected (p0010 > 0).
 - there is an OFF2 fault response.
 - the drive is not operational.
- Bit 18 = 1 (enable signal missing), if:
- OFF3 has still not been completed or an OFF3 fault response is present.
- Bit 19 = 1 (internal pulse enable missing), if:
- sequence control does not have a finished message.
- Bit 20 = 1 (internal DC brake active), if:
- the drive is not in the state "Operation" or in "OFF1/OFF3".
 - the internal pulse enable is missing (r0046.19 = 0).
- Bit 21 = 1 (enable signal missing), if:
- the power unit does not issue an enable signal (e.g. because DC link voltage is too low).
 - the holding brake opening time (p1216) has still not expired.
 - the hibernation mode is active.
- Bit 26 = 1 (enable signal missing), if:
- the drive is not operational.
- Bit 27 = 1 (enable signal missing), if:
- de-magnetization not completed.
- Bit 28 = 1 (enable signal missing), if:
- the holding brake is closed or has still not been opened.
- Bit 30 = 1 (speed controller inhibited), if one of the following reasons is present:
- the pole position identification is active.
 - motor data identification is active (only certain steps).
- Bit 31 = 1 (enable signal missing), if:
- the speed setpoint from jog 1 or 2 is entered.

r0047	Motor data identification and speed controller optimization / MotID and n_opt			
	Access level: 1	Calculated: -	Data type: Integer16	
	Can be changed: -	Scaling: -	Dyn. index: -	
	Unit group: -	Unit selection: -	Func. diagram: -	
	Min	Max	Factory setting	
	0	300	-	
Description:	Displays the actual status for the motor data identification (stationary measurement) and the speed controller optimization (rotating measurement).			
Value:	0: No measurement 115: Measurement q leakage inductance (part 2) 120: Speed controller optimization (vibration test) 140: Calculate speed controller setting 150: Measurement moment of inertia 170: Measurement magnetizing current and saturation characteristic 195: Measurement q leakage inductance (part 1) 200: Rotating measurement selected 220: identification leakage inductance 230: Identification rotor time constant 240: Identification stator inductance 250: Identification stator inductance LQLD 260: Identification circuit 270: Identification stator resistance 290: Identification valve lockout time 300: Stationary measurement selected			
r0050.0...1	CO/BO: Command Data Set CDS effective / CDS effective			
	Access level: 3	Calculated: -	Data type: Unsigned8	
	Can be changed: -	Scaling: -	Dyn. index: -	
	Unit group: -	Unit selection: -	Func. diagram: 8560	
	Min	Max	Factory setting	
	-	-	-	
Description:	Displays the effective Command Data Set (CDS).			
Bit field:	Bit	Signal name	1 signal	0 signal
	00	CDS effective bit 0	ON	OFF
	01	CDS effective bit 1	ON	OFF
Dependency:	Refer to: p0810, p0811, r0836			
Note:	The Command Data Set selected using a binector input (e.g. p0810) is displayed using r0836.			
r0051.0...1	CO/BO: Drive Data Set DDS effective / DDS effective			
	Access level: 2	Calculated: -	Data type: Unsigned8	
	Can be changed: -	Scaling: -	Dyn. index: -	
	Unit group: -	Unit selection: -	Func. diagram: 8565	
	Min	Max	Factory setting	
	-	-	-	
Description:	Displays the effective Drive Data Set (DDS).			
Bit field:	Bit	Signal name	1 signal	0 signal
	00	DDS effective bit 0	ON	OFF
	01	DDS effective bit 1	ON	OFF
Dependency:	Refer to: p0820, p0821, r0837			
Note:	When selecting the motor data identification routine and the rotating measurement, the drive data set changeover is suppressed.			

r0052.0...15	CO/BO: Status word 1 / ZSW 1				
	Access level: 2	Calculated: -	Data type: Unsigned16		
	Can be changed: -	Scaling: -	Dyn. index: -		
	Unit group: -	Unit selection: -	Func. diagram: -		
	Min	Max	Factory setting		
	-	-	-		
Description:	Display and connector output for status word 1.				
Bit field:	Bit	Signal name	1 signal	0 signal	FP
	00	Ready for switching on	Yes	No	-
	01	Ready	Yes	No	-
	02	Operation enabled	Yes	No	-
	03	Fault present	Yes	No	-
	04	Coast down active (OFF2)	No	Yes	-
	05	Quick Stop active (OFF3)	No	Yes	-
	06	Switching on inhibited active	Yes	No	-
	07	Alarm present	Yes	No	-
	08	Deviation setpoint/actual speed	No	Yes	-
	09	Control request	Yes	No	-
	10	Maximum speed exceeded	Yes	No	-
	11	I, M, P limit reached	No	Yes	-
	12	Motor holding brake open	Yes	No	-
	13	Alarm motor overtemperature	No	Yes	-
	14	Motor rotates forwards	Yes	No	-
	15	Alarm drive converter overload	No	Yes	-
Notice:	p2080 is used to define the signal sources of the PROFIdrive status word interconnection.				
Note:	For bit 03: This signal is inverted if it is interconnected to a digital output. For r0052: The status bits have the following sources: Bit 00: r0899 Bit 0 Bit 01: r0899 Bit 1 Bit 02: r0899 Bit 2 Bit 03: r2139 Bit 3 (or r1214.10 for p1210 > 0) Bit 04: r0899 bit 4 (or r8559.11 for local remote control) Bit 05: r0899 Bit 5 Bit 06: r0899 Bit 6 Bit 07: r2139 Bit 7 Bit 08: r2197 Bit 7 Bit 09: r0899 Bit 7 Bit 10: r2197 bit 12 Bit 11: r0056 Bit 13 (negated) Bit 12: r0899 Bit 12 Bit 13: r2135 Bit 14 (negated) Bit 14: r2197 Bit 3 Bit 15: r2135 Bit 15 (negated)				

r0053.0...13	CO/BO: Status word 2 / ZSW 2			
G115D ASI	Access level: 2	Calculated: -	Data type: Unsigned16	
	Can be changed: -	Scaling: -	Dyn. index: -	
	Unit group: -	Unit selection: -	Func. diagram: -	
	Min	Max	Factory setting	
	-	-	-	
Description:	Display and BICO output for status word 2.			

Bit field:	Bit	Signal name	1 signal	0 signal	FP
	00	DC braking active	Yes	No	-
	01	n_act > p1226 (n_standstill)	Yes	No	-
	02	n_act > p1080 (n_min)	Yes	No	-
	03	I_act >= p2170	Yes	No	-
	04	n_act > p2155	Yes	No	-
	05	n_act <= p2155	Yes	No	-
	06	n_act >= r1119 (n_set)	Yes	No	-
	07	Vdc <= p2172	Yes	No	-
	08	Vdc > p2172	Yes	No	-
	09	Ramp-up/ramp-down completed	Yes	No	-
	10	Technology controller output at the lower limit	Yes	No	-
	11	Technology controller output at the upper limit	Yes	No	-
	13	Ready for switching on from the PLC	Yes	No	-

Notice: p2081 is used to define the signal sources of the PROFIdrive status word interconnection.

Note: The following status bits are displayed in r0053:

Bit 00: r1239 Bit 8

Bit 01: r2197 Bit 5 (negated)

Bit 02: r2197 Bit 0 (negated)

Bit 03: r2197 Bit 8

Bit 04: r2197 Bit 2

Bit 05: r2197 Bit 1

Bit 06: r2197 Bit 4

Bit 07: r2197 Bit 9

Bit 08: r2197 Bit 10

Bit 09: r1199 Bit 2 (negated)

Bit 10: r2349 Bit 10

Bit 11: r2349 Bit 11

r0053.0...11

CO/BO: Status word 2 / ZSW 2

G115D I/O	Access level: 2	Calculated: -	Data type: Unsigned16
G115D PN	Can be changed: -	Scaling: -	Dyn. index: -
	Unit group: -	Unit selection: -	Func. diagram: -
	Min	Max	Factory setting
	-	-	-

Description: Display and BICO output for status word 2.

Bit field:	Bit	Signal name	1 signal	0 signal	FP
	00	DC braking active	Yes	No	-
	01	n_act > p1226 (n_standstill)	Yes	No	-
	02	n_act > p1080 (n_min)	Yes	No	-
	03	I_act >= p2170	Yes	No	-
	04	n_act > p2155	Yes	No	-
	05	n_act <= p2155	Yes	No	-
	06	n_act >= r1119 (n_set)	Yes	No	-
	07	Vdc <= p2172	Yes	No	-
	08	Vdc > p2172	Yes	No	-
	09	Ramp-up/ramp-down completed	Yes	No	-
	10	Technology controller output at the lower limit	Yes	No	-
	11	Technology controller output at the upper limit	Yes	No	-

Notice: p2081 is used to define the signal sources of the PROFIdrive status word interconnection.

2 Parameters

2.2 List of parameters

Note: The following status bits are displayed in r0053:

Bit 00: r1239 Bit 8
 Bit 01: r2197 Bit 5 (negated)
 Bit 02: r2197 Bit 0 (negated)
 Bit 03: r2197 Bit 8
 Bit 04: r2197 Bit 2
 Bit 05: r2197 Bit 1
 Bit 06: r2197 Bit 4
 Bit 07: r2197 Bit 9
 Bit 08: r2197 Bit 10
 Bit 09: r1199 Bit 2 (negated)
 Bit 10: r2349 Bit 10
 Bit 11: r2349 Bit 11

r0054.0...15

CO/BO: Control word 1 / STW 1

Access level: 2 **Calculated:** - **Data type:** Unsigned16
Can be changed: - **Scaling:** - **Dyn. index:** -
Unit group: - **Unit selection:** - **Func. diagram:** -
Min **Max** **Factory setting**
 - - -

Description: Displays control word 1.

Bit field:	Bit	Signal name	1 signal	0 signal	FP
	00	ON/OFF1	Yes	No	-
	01	OC / OFF2	No	Yes	-
	02	OC / OFF3	No	Yes	-
	03	Enable operation	Yes	No	-
	04	Enable ramp-function generator	Yes	No	-
	05	Continue ramp-function generator	Yes	No	-
	06	Enable speed setpoint	Yes	No	-
	07	Acknowledge fault	Yes	No	-
	08	Jog bit 0	Yes	No	3030
	09	Jog bit 1	Yes	No	3030
	10	Master control by PLC	Yes	No	-
	11	Direction reversal (setpoint)	Yes	No	-
	13	Motorized potentiometer raise	Yes	No	-
	14	Motorized potentiometer lower	Yes	No	-
	15	CDS bit 0	Yes	No	-

Note: The following control bits are displayed in r0054:

Bit 00: r0898 Bit 0
 Bit 01: r0898 Bit 1
 Bit 02: r0898 Bit 2
 Bit 03: r0898 Bit 3
 Bit 04: r0898 Bit 4
 Bit 05: r0898 Bit 5
 Bit 06: r0898 Bit 6
 Bit 07: r2138 Bit 7
 Bit 08: r0898 Bit 8
 Bit 09: r0898 Bit 9
 Bit 10: r0898 Bit 10
 Bit 11: r1198 Bit 11
 Bit 13: r1198 Bit 13
 Bit 14: r1198 Bit 14
 Bit 15: r0836 Bit 0

r0055.0...15		CO/BO: Supplementary control word / Suppl STW			
Access level: 3		Calculated: -	Data type: Unsigned16		
Can be changed: -		Scaling: -	Dyn. index: -		
Unit group: -		Unit selection: -	Func. diagram: 2513		
Min		Max	Factory setting		
-		-	-		
Description:	Display and BICO output for supplementary control word.				
Bit field:	Bit	Signal name	1 signal	0 signal	FP
	00	Fixed setpoint bit 0	Yes	No	-
	01	Fixed setpoint bit 1	Yes	No	-
	02	Fixed setpoint bit 2	Yes	No	-
	03	Fixed setpoint bit 3	Yes	No	-
	04	DDS selection bit 0	Yes	No	-
	05	DDS selection bit 1	Yes	No	-
	06	Quick stop deselected	Yes	No	-
	08	Technology controller enable	Yes	No	-
	09	DC braking enable	Yes	No	-
	11	Droop enable	Yes	No	-
	12	Torque control active	Yes	No	-
	13	External fault 1 (F07860)	No	Yes	-
	15	CDS bit 1	Yes	No	-
Note:	CDS: Command Data Set DDS: Drive Data Set The following control bits are displayed in r0055: Bit 00: r1198.0 Bit 01: r1198.1 Bit 02: r1198.2 Bit 03: r1198.3 Bit 04: r0837.0 Bit 05: r0837.1 Bit 06: r0885.4 (negated) Bit 08: r2349.0 (negated) Bit 09: r1239.11 Bit 11: r1406.11 Bit 12: r1406.12 Bit 13: r2138.13 (negated) Bit 15: r0836.1				

r0056.0...15		CO/BO: Status word, closed-loop control / ZSW cl-loop ctrl			
Access level: 3		Calculated: -	Data type: Unsigned16		
Can be changed: -		Scaling: -	Dyn. index: -		
Unit group: -		Unit selection: -	Func. diagram: 2526		
Min		Max	Factory setting		
-		-	-		
Description:	Display and BICO output for the status word of the closed-loop control.				
Bit field:	Bit	Signal name	1 signal	0 signal	FP
	00	Initialization completed	Yes	No	-
	01	De-magnetizing completed	Yes	No	-
	02	Pulse enable available	Yes	No	-
	03	Soft starting present	Yes	No	-
	04	Magnetizing completed	Yes	No	-
	05	Voltage boost when starting	Active	Inactive	6301

2 Parameters

2.2 List of parameters

06	Acceleration voltage	Active	Inactive	6301
07	Frequency negative	Yes	No	-
08	Field weakening active	Yes	No	-
09	Voltage limit active	Yes	No	6714
10	Slip limit active	Yes	No	6310
11	Frequency limit active	Yes	No	-
12	Current limiting controller voltage output active	Yes	No	-
13	Current/torque limiting	Active	Inactive	6060
14	Vdc_max controller active	Yes	No	6220, 6320
15	Vdc_min controller active	Yes	No	6220, 6320

r0060

CO: Speed setpoint before the setpoint filter / n_set before filt.

Access level: 3	Calculated: -	Data type: FloatingPoint32
Can be changed: -	Scaling: p2000	Dyn. index: -
Unit group: 3_1	Unit selection: p0505	Func. diagram: 2701, 6030, 6799
Min - [rpm]	Max - [rpm]	Factory setting - [rpm]

Description: Displays the actual speed setpoint at the input of the speed controller or U/f characteristic (after the interpolator).

Dependency: Refer to: r0020

Note: The speed setpoint is available smoothed (r0020) and unsmoothed (r0060).

r0062

CO: Speed setpoint after the filter / n_set after filter

Access level: 3	Calculated: -	Data type: FloatingPoint32
Can be changed: -	Scaling: p2000	Dyn. index: -
Unit group: 3_1	Unit selection: p0505	Func. diagram: 6020, 6030, 6031
Min - [rpm]	Max - [rpm]	Factory setting - [rpm]

Description: Display and connector output for the speed setpoint after the setpoint filters.

r0063[0...2]

CO: Actual speed / Actual speed

Access level: 3	Calculated: -	Data type: FloatingPoint32
Can be changed: -	Scaling: p2000	Dyn. index: -
Unit group: 3_1	Unit selection: p0505	Func. diagram: 6020, 6799
Min - [rpm]	Max - [rpm]	Factory setting - [rpm]

Description: Display and connector output for the speed actual value.
Frequency components from the slip compensation (for induction motors) are not included.

Index:
[0] = Unsmoothed
[1] = Smoothed with p0045
[2] = Calculated from f_set - f_slip (unsmoothed)

Dependency: Refer to: r0021, r0022

Note: The speed actual value r0063[0] – smoothed with p0045 – is additionally displayed in r0063[1]. r0063[1] can be used as process variable for the appropriate smoothing time constant p0045.

The speed (r0063[2]) calculated from the output frequency and slip can only be compared with the speed actual value (r0063[0]) in the steady-state.

For U/f control, the mechanical speed calculated from the output frequency and the slip is shown in r0063[2] even if slip compensation is deactivated.

r0064	CO: Speed controller system deviation / n_ctrl sys dev		
	Access level: 3	Calculated: -	Data type: FloatingPoint32
	Can be changed: -	Scaling: p2000	Dyn. index: -
	Unit group: 3_1	Unit selection: p0505	Func. diagram: 6040
	Min	Max	Factory setting
	- [rpm]	- [rpm]	- [rpm]
Description:	Displays the actual system deviation of the speed controller.		
r0065	Slip frequency / f_Slip		
	Access level: 3	Calculated: -	Data type: FloatingPoint32
	Can be changed: -	Scaling: p2000	Dyn. index: -
	Unit group: 2_1	Unit selection: p0505	Func. diagram: 6310, 6700, 6727, 6730, 6732
	Min	Max	Factory setting
	- [Hz]	- [Hz]	- [Hz]
Description:	Displays the slip frequency for induction motors (ASM).		
r0066	CO: Output frequency / f_outp		
	Access level: 3	Calculated: -	Data type: FloatingPoint32
	Can be changed: -	Scaling: p2000	Dyn. index: -
	Unit group: 2_1	Unit selection: p0505	Func. diagram: 6300, 6700, 6730, 6731, 6799
	Min	Max	Factory setting
	- [Hz]	- [Hz]	- [Hz]
Description:	Display and connector output for the unsmoothed output frequency of the power unit. Frequency components from the slip compensation (induction motor) are included.		
Dependency:	Refer to: r0024		
Note:	The output frequency is available smoothed (r0024) and unsmoothed (r0066).		
r0067	CO: Output current maximum / Current max		
	Access level: 3	Calculated: -	Data type: FloatingPoint32
	Can be changed: -	Scaling: p2002	Dyn. index: -
	Unit group: 6_2	Unit selection: p0505	Func. diagram: 6300, 6640, 6724
	Min	Max	Factory setting
	- [Arms]	- [Arms]	- [Arms]
Description:	Display and connector output for the maximum output current of the power unit.		
Dependency:	The maximum output current is determined by the parameterized current limit and the motor and converter thermal protection. Refer to: p0290, p0640		
r0068[0...1]	CO: Absolute current actual value / I_act abs val		
	Access level: 3	Calculated: -	Data type: FloatingPoint32
	Can be changed: -	Scaling: p2002	Dyn. index: -
	Unit group: 6_2	Unit selection: p0505	Func. diagram: 6300, 6714, 6799, 7017, 8017, 8021, 8022
	Min	Max	Factory setting
	- [Arms]	- [Arms]	- [Arms]
Description:	Displays actual absolute current.		
Index:	[0] = Unsmoothed [1] = Smoothed with p0045		
Dependency:	Refer to: r0027		
Notice:	The value is updated with the current controller sampling time.		

2 Parameters

2.2 List of parameters

Note: Absolute current value = $\sqrt{I_q^2 + I_d^2}$
The absolute value of the current actual value is available smoothed (r0027 with 300 ms, r0068[1] with p0045) and unsmoothed (r0068[0]).

r0069[0...8]	CO: Phase current actual value / I_{phase act val}		
	Access level: 4	Calculated: -	Data type: FloatingPoint32
	Can be changed: -	Scaling: p2002	Dyn. index: -
	Unit group: 6_5	Unit selection: p0505	Func. diagram: 6730, 6731
	Min	Max	Factory setting
	- [A]	- [A]	- [A]
Description:	Display and connector output for the measured actual phase currents as peak value.		
Index:	[0] = Phase U [1] = Phase V [2] = Phase W [3] = Phase U offset [4] = Phase V offset [5] = Phase W offset [6] = Total U, V, W [7] = Alpha component [8] = Beta component		
Note:	In indices 3 ... 5, the offset currents of the 3 phases, which are added to correct the phase currents, are displayed. The sum of the 3 corrected phase currents is displayed in index 6.		

r0070	CO: Actual DC link voltage / V_{dc act val}		
	Access level: 3	Calculated: -	Data type: FloatingPoint32
	Can be changed: -	Scaling: p2001	Dyn. index: -
	Unit group: 5_2	Unit selection: p0505	Func. diagram: 6723, 6724, 6730, 6731, 6799
	Min	Max	Factory setting
	- [V]	- [V]	- [V]
Description:	Display and connector output for the measured actual value of the DC link voltage.		
Dependency:	Refer to: r0026		
Note:	When measuring a DC link voltage < 200 V, for the Power Module a valid measured value is not supplied. In this case, when an external 24 V power supply is connected, a value of approx. 24 V is displayed in the display parameter.		
Note:	The DC link voltage is available smoothed (r0026) and unsmoothed (r0070).		

r0071	Maximum output voltage / Voltage max		
	Access level: 3	Calculated: -	Data type: FloatingPoint32
	Can be changed: -	Scaling: p2001	Dyn. index: -
	Unit group: 5_1	Unit selection: p0505	Func. diagram: 6301, 6640, 6700, 6722, 6723, 6724, 6725, 6727
	Min	Max	Factory setting
	- [V _{rms}]	- [V _{rms}]	- [V _{rms}]
Description:	Displays the maximum output voltage.		
Dependency:	The maximum output voltage depends on the actual DC link voltage (r0070) and the maximum modulation depth (p1803).		
Note:	As the (driven) motor load increases, the maximum output voltage drops as a result of the reduction in DC link voltage.		

r0072	CO: Output voltage / U_output		
	Access level: 3	Calculated: -	Data type: FloatingPoint32
	Can be changed: -	Scaling: p2001	Dyn. index: -
	Unit group: 5_1	Unit selection: p0505	Func. diagram: 5700, 6730, 6731, 6799
	Min	Max	Factory setting
	- [Vrms]	- [Vrms]	- [Vrms]
Description:	Display and connector output for the actual output voltage of the power unit.		
Dependency:	Refer to: r0025		
Note:	The output voltage is available smoothed (r0025) and unsmoothed (r0072).		
r0073	Maximum modulation depth / Modulat_depth max		
	Access level: 4	Calculated: -	Data type: FloatingPoint32
	Can be changed: -	Scaling: PERCENT	Dyn. index: -
	Unit group: -	Unit selection: -	Func. diagram: 6723, 6724
	Min	Max	Factory setting
	- [%]	- [%]	- [%]
Description:	Displays the maximum modulation depth.		
Dependency:	Refer to: p1803		
r0074	CO: Modulat_depth / Mod_depth		
	Access level: 4	Calculated: -	Data type: FloatingPoint32
	Can be changed: -	Scaling: PERCENT	Dyn. index: -
	Unit group: -	Unit selection: -	Func. diagram: 6730, 6731, 6799
	Min	Max	Factory setting
	- [%]	- [%]	- [%]
Description:	Display and connector output for the actual modulation depth.		
Dependency:	Refer to: r0028		
Note:	For space vector modulation, 100% corresponds to the maximum output voltage without overcontrol. Values above 100 % indicate an overcontrol condition - values below 100% have no overcontrol. The phase voltage (phase-to-phase, rms) is calculated as follows: $(r0074 \times r0070) / (\sqrt{2} \times 100 \%)$. The modulation depth is available smoothed (r0028) and unsmoothed (r0074).		
r0075	CO: Current setpoint field-generating / Id_set		
	Access level: 3	Calculated: -	Data type: FloatingPoint32
	Can be changed: -	Scaling: p2002	Dyn. index: -
	Unit group: 6_2	Unit selection: p0505	Func. diagram: 6700, 6714, 6725
	Min	Max	Factory setting
	- [Arms]	- [Arms]	- [Arms]
Description:	Display and connector output for the field-generating current setpoint (Id_set).		
Note:	This value is irrelevant for the U/f control mode.		
r0076	CO: Current actual value field-generating / Id_act		
	Access level: 3	Calculated: -	Data type: FloatingPoint32
	Can be changed: -	Scaling: p2002	Dyn. index: -
	Unit group: 6_2	Unit selection: p0505	Func. diagram: 5700, 5714, 5730, 6700, 6714, 6799
	Min	Max	Factory setting
	- [Arms]	- [Arms]	- [Arms]
Description:	Display and connector output for the field-generating current actual value (Id_act).		
Dependency:	Refer to: r0029		

2 Parameters

2.2 List of parameters

Note: This value is irrelevant for the *Uf* control mode.
The field-generating current actual value is available smoothed (r0029) and unsmoothed (r0076).

r0077 **CO: Current setpoint torque-generating / Iq_set**

Access level: 3	Calculated: -	Data type: FloatingPoint32
Can be changed: -	Scaling: p2002	Dyn. index: -
Unit group: 6_2	Unit selection: p0505	Func. diagram: 6700, 6710
Min - [Arms]	Max - [Arms]	Factory setting - [Arms]

Description: Display and connector output for the torque-generating current setpoint.
Note: This value is irrelevant for the *Uf* control mode.

r0078 **CO: Current actual value torque-generating / Iq_act**

Access level: 3	Calculated: -	Data type: FloatingPoint32
Can be changed: -	Scaling: p2002	Dyn. index: -
Unit group: 6_2	Unit selection: p0505	Func. diagram: 6310, 6700, 6714, 6799
Min - [Arms]	Max - [Arms]	Factory setting - [Arms]

Description: Display and connector output for the torque-generating current actual value (Iq_act).
Dependency: Refer to: r0030
Note: This value is irrelevant for the *Uf* control mode.
The torque-generating current actual value is available smoothed (r0030 with 300 ms) and unsmoothed (r0078).

r0079 **CO: Torque setpoint / M_set**

Access level: 3	Calculated: -	Data type: FloatingPoint32
Can be changed: -	Scaling: p2003	Dyn. index: -
Unit group: 7_1	Unit selection: p0505	Func. diagram: 6020, 6060, 6710
Min - [Nm]	Max - [Nm]	Factory setting - [Nm]

Description: Display and connector output for the torque setpoint at the output of the speed controller.

r0080[0...1] **CO: Torque actual value / Actual torque**

Access level: 3	Calculated: -	Data type: FloatingPoint32
Can be changed: -	Scaling: p2003	Dyn. index: -
Unit group: 7_1	Unit selection: p0505	Func. diagram: 6714, 6799
Min - [Nm]	Max - [Nm]	Factory setting - [Nm]

Description: Display and connector output for actual torque value.
Index: [0] = Unsmoothed
[1] = Smoothed with p0045
Dependency: Refer to: r0031, p0045
Note: The value is available smoothed (r0031 with 100 ms, r0080[1] with p0045) and unsmoothed (r0080[0]).

r0081 **CO: Torque utilization / M_Utilization**

Access level: 4	Calculated: -	Data type: FloatingPoint32
Can be changed: -	Scaling: PERCENT	Dyn. index: -
Unit group: -	Unit selection: -	Func. diagram: 8012
Min - [%]	Max - [%]	Factory setting - [%]

Description: Displays the torque utilization as a percentage.
The torque utilization is obtained from the required smoothed torque referred to the torque limit.

Dependency: This parameter is only available for vector control. For U/f control r0081 = 0 %.

Refer to: r0033

Note: The torque utilization is available smoothed (r0033) and unsmoothed (r0081).

The torque utilization is obtained from the required torque referred to the torque limit as follows:

- Positive torque: $r0081 = (r0079 / r1538) * 100 \%$

- Negative torque: $r0081 = (-r0079 / -r1539) * 100 \%$

r0082[0...2]**CO: Active power actual value / P_act**

Access level: 3

Calculated: -

Data type: FloatingPoint32

Can be changed: -

Scaling: r2004

Dyn. index: -

Unit group: 14_5

Unit selection: p0505

Func. diagram: 6714, 6799

Min

Max

Factory setting

- [kW]

- [kW]

- [kW]

Description: Displays the instantaneous active power.

Index: [0] = Unsmoothed

[1] = Smoothed with p0045

[2] = Electric power

Dependency: Refer to: r0032

Note: The mechanical active power is available smoothed (r0032 with 100 ms, r0082[1] with p0045) and unsmoothed (r0082[0]).

r0083**CO: Flux setpoint / Flux setp**

Access level: 4

Calculated: -

Data type: FloatingPoint32

Can be changed: -

Scaling: PERCENT

Dyn. index: -

Unit group: -

Unit selection: -

Func. diagram: 5722

Min

Max

Factory setting

- [%]

- [%]

- [%]

Description: Displays the flux setpoint.

r0084[0...1]**CO: Flux actual value / Actual flux**

Access level: 4

Calculated: -

Data type: FloatingPoint32

Can be changed: -

Scaling: PERCENT

Dyn. index: -

Unit group: -

Unit selection: -

Func. diagram: 6730, 6731

Min

Max

Factory setting

- [%]

- [%]

- [%]

Description: Displays the flux actual value.

Index: [0] = Unsmoothed

[1] = Smoothed

r0087**CO: Actual power factor / Cos phi act**

Access level: 3

Calculated: -

Data type: FloatingPoint32

Can be changed: -

Scaling: -

Dyn. index: -

Unit group: -

Unit selection: -

Func. diagram: -

Min

Max

Factory setting

-

-

-

Description: Displays the actual active power factor.

This value refers to the electrical power of the basic fundamental signals at the output terminals of the converter.

2 Parameters

2.2 List of parameters

r0089[0...2]	Actual phase voltage / U_phase act val		
	Access level: 4	Calculated: -	Data type: FloatingPoint32
	Can be changed: -	Scaling: p2001	Dyn. index: -
	Unit group: 5_3	Unit selection: p0505	Func. diagram: 6730
	Min	Max	Factory setting
	- [V]	- [V]	- [V]
Description:	Displays the actual phase voltage.		
Index:	[0] = Phase U [1] = Phase V [2] = Phase W		
Note:	The values are determined from the transistor switch-on duration.		
r0094	CO: Transformation angle / Transformat_angle		
	Access level: 3	Calculated: -	Data type: FloatingPoint32
	Can be changed: -	Scaling: p2005	Dyn. index: -
	Unit group: -	Unit selection: -	Func. diagram: -
	Min	Max	Factory setting
	- [°]	- [°]	- [°]
Description:	Displays the transformation angle.		
Dependency:	Refer to: r1778		
Note:	The transformation angle corresponds to the electrical commutation angle.		
p0100	IEC/NEMA Standards / IEC/NEMA Standards		
	Access level: 1	Calculated: -	Data type: Integer16
	Can be changed: C(1, 2)	Scaling: -	Dyn. index: -
	Unit group: -	Unit selection: -	Func. diagram: -
	Min	Max	Factory setting
	0	2	0
Description:	Defines whether the motor and drive converter power settings (e.g. rated motor power, p0307) are expressed in [kW] or [hp]. Depending on the selection, the rated motor frequency (p0310) is either set to 50 Hz or 60 Hz. For p0100 = 0, 2, the following applies: The power factor (p0308) should be parameterized. For p0100 = 1, the following applies: The efficiency (p0309) should be parameterized.		
Value:	0: IEC (50 Hz line, SI units) 1: NEMA (60 Hz line, US units) 2: NEMA (60 Hz line, SI units)		
Dependency:	If p0100 is changed, all of the rated motor parameters are reset. Only then are possible unit changeovers made. The units of all motor parameters are changed that are involved in the selection of IEC or NEMA (e.g. r0206, p0307, r0333, r0334, p0341, p0344, r1969). Refer to: r0206, p0210, p0300, p0304, p0305, p0307, p0308, p0309, p0310, p0311, p0314, p0320, p0322, p0323, p0335, r0337, p1800		
Note:	The parameter value is not reset when the factory setting is restored (p0010 = 30, p0970).		
p0124[0...n]	CU detection via LED / CU detection LED		
	Access level: 3	Calculated: -	Data type: Unsigned8
	Can be changed: U, T	Scaling: -	Dyn. index: -
	Unit group: -	Unit selection: -	Func. diagram: -
	Min	Max	Factory setting
	0	1	0
Description:	Identification of the Control Unit using an LED.		
Note:	While p0124 = 1, the READY LED flashes green/orange or red/orange with 2 Hz at the appropriate Control Unit.		

p0133[0...n]	Motor configuration / Motor config				
	Access level: 2	Calculated: -	Data type: Unsigned16		
	Can be changed: C(1, 3)	Scaling: -	Dyn. index: DDS, p0180		
	Unit group: -	Unit selection: -	Func. diagram: -		
	Min	Max	Factory setting		
	-	-	0100 bin		
Description:	Configuration of the motor when commissioning the motor.				
Bit field:	Bit	Signal name	1 signal	0 signal	FP
	00	Motor connection type	Delta	Star	-
	01	Motor 87/104 Hz operation	Yes	No	-
	02	Increase maximum motor speed	Yes	No	-
Dependency:	For standard induction motors (p0301 > 10000), bit 0 is automatically pre-assigned the connection type of the selected data set.				
	Refer to: p0304, p0305, p1082				
Note:	For bit 00:				
	When changing the bits, the rated motor voltage p0304 and the rated motor current p0305 are automatically converted to the selected connection type (star/delta).				
	For bit 01:				
	87 Hz operation is only possible in the delta connection type. When selected, the maximum speed p1082 is automatically pre-assigned for a maximum output frequency of 87 Hz (for p0100 = IEC) or 104 Hz (for p0100 = NEMA).				
	Bit 01 should not be set = 1 for 2KJ8 motors.				
	For bit 02:				
	When commissioning, maximum speed p1082 is increased by 20 percent with respect to the default setting.				
p0170	Number of Command Data Sets (CDS) / CDS count				
	Access level: 2	Calculated: -	Data type: Unsigned8		
	Can be changed: C(15)	Scaling: -	Dyn. index: -		
	Unit group: -	Unit selection: -	Func. diagram: 8560		
	Min	Max	Factory setting		
	2	4	2		
Description:	Sets the number of Command Data Sets (CDS).				
Dependency:	Refer to: p0010, r3996				
Notice:	When the data sets are created, short-term communication interruptions may occur.				
Note:	It is possible to toggle between command parameters (BICO parameters) using this data set changeover.				
p0180	Number of Drive Data Sets (DDS) / DDS count				
	Access level: 3	Calculated: -	Data type: Unsigned8		
	Can be changed: C(15)	Scaling: -	Dyn. index: -		
	Unit group: -	Unit selection: -	Func. diagram: 8565		
	Min	Max	Factory setting		
	1	4	1		
Description:	Sets the number of Drive Data Sets (DDS).				
Dependency:	Refer to: p0010, r3996				
Notice:	When the data sets are created, short-term communication interruptions may occur.				

r0197[0...1]	Bootloader version / Bootloader vers		
	Access level: 4	Calculated: -	Data type: Unsigned32
	Can be changed: -	Scaling: -	Dyn. index: -
	Unit group: -	Unit selection: -	Func. diagram: -
	Min	Max	Factory setting
	-	-	-
Description:	Displays the bootloader version. Index 0: Displays the bootloader version. Index 1: Displays the bootloader version 3 (for CU320-2 and CU310-2) Value 0 means that boot loader 3 is not available.		
Dependency:	Refer to: r0018, r0198		
Note:	Example: The value 1010100 should be interpreted as V01.01.01.00.		
r0198[0...2]	BIOS/EEPROM data version / BIOS/EEPROM vers		
	Access level: 4	Calculated: -	Data type: Unsigned32
	Can be changed: -	Scaling: -	Dyn. index: -
	Unit group: -	Unit selection: -	Func. diagram: -
	Min	Max	Factory setting
	-	-	-
Description:	Displays the BIOS and EEPROM data version. r0198[0]: BIOS version r0198[1]: EEPROM data version EEPROM 0 r0198[2]: EEPROM data version EEPROM 1		
Dependency:	Refer to: r0018, r0197		
Note:	Example: The value 1010100 should be interpreted as V01.01.01.00.		
r0200[0...n]	Power unit code number actual / PU code no. act		
	Access level: 3	Calculated: -	Data type: Unsigned16
	Can be changed: -	Scaling: -	Dyn. index: -
	Unit group: -	Unit selection: -	Func. diagram: -
	Min	Max	Factory setting
	-	-	-
Description:	Displays the unique code number of the power unit.		
Note:	r0200 = 0: No power unit data found		
p0201[0...n]	Power unit code number / PU code no		
	Access level: 3	Calculated: -	Data type: Unsigned16
	Can be changed: C(2)	Scaling: -	Dyn. index: -
	Unit group: -	Unit selection: -	Func. diagram: -
	Min	Max	Factory setting
	0	65535	0
Description:	Sets the actual code number from r0200 to acknowledge the power unit being used. When commissioned for the first time, the code number is automatically transferred from r0200 into p0201.		
Note:	The parameter is used to identify when the drive is being commissioned for the first time. The power unit commissioning can only be exited (p0201 = r0200), if the actual and acknowledged code numbers are identical (p0010 = 2). When the code number is changed, the connection voltage (p0210) is checked and, if necessary, adjusted.		

r0203[0...n]	Actual power unit type / PU actual type		
	Access level: 3	Calculated: -	Data type: Integer16
	Can be changed: -	Scaling: -	Dyn. index: -
	Unit group: -	Unit selection: -	Func. diagram: -
	Min	Max	Factory setting
	2	400	-
Description:	Displays the type of power unit found.		
Value:	2: MICROMASTER 440 3: MICROMASTER 411 4: MICROMASTER 410 5: MICROMASTER 436 6: MICROMASTER 440 PX 7: MICROMASTER 430 100: SINAMICS S 101: SINAMICS S (value) 102: SINAMICS S (combi) 103: SINAMICS S120M (distributed) 112: PM220 (SINAMICS G120) 113: PM230 (SINAMICS G120) 114: PM240 (SINAMICS G120 / S120) 115: PM250 (SINAMICS G120 / S120) 116: PM260 (SINAMICS G120) 118: SINAMICS G120 Px 120: PM340 (SINAMICS S120 / G120) 126: SINAMICS ET200PRO 130: PM250D (SINAMICS G120D) 133: SINAMICS G120C 135: SINAMICS PMV40 136: SINAMICS PMV60 137: SINAMICS PMV80 138: SINAMICS G110M 140: SINAMICS G120X/G120XA 142: SINAMICS G115D 150: SINAMICS G 151: PM330 (SINAMICS G120) 200: SINAMICS GM 250: SINAMICS SM 260: SINAMICS MC 300: SINAMICS GL 350: SINAMICS SL 400: SINAMICS DCM		
Note:	For parallel circuit configurations, the parameter index is assigned to a power unit.		

r0204[0...n]	Power unit hardware properties / PU HW property				
	Access level: 3	Calculated: -	Data type: Unsigned32		
	Can be changed: -	Scaling: -	Dyn. index: -		
	Unit group: -	Unit selection: -	Func. diagram: -		
	Min	Max	Factory setting		
	-	-	-		
Description:	Displays the properties supported by the power unit hardware.				
Bit field:	Bit	Signal name	1 signal	0 signal	FP
	01	RFI filter available	Yes	No	-
	07	F3E regenerative feedback into the line supply	Yes	No	-
	08	Internal Braking Module	Yes	No	-
	12	Safe Brake Control (SBC) supported	No	Yes	-
	13	Safety Integrated supported	Yes	No	-
	14	Internal LC output filter	Yes	No	-
	15	Line voltage	1-phase	3-phase	-

p0205	Power unit application / PU application		
	Access level: 1	Calculated: -	Data type: Integer16
	Can be changed: C(1, 2)	Scaling: -	Dyn. index: -
	Unit group: -	Unit selection: -	Func. diagram: -
	Min	Max	Factory setting
	0	7	0
Description:	The duty cycles can be overloaded provided that the drive converter is operated with its base load current before and after the overload. This is based on a load duty cycle of 300 s.		
Value:	0: Load duty cycle with high overload for vector drives 1: Load duty cycle with low overload for vector drives 6: S1 duty cycle (for internal use) 7: S6 duty cycle (for internal use)		
Dependency:	Refer to: r3996		
Notice:	The parameter value is not reset when the factory setting is restored (see p0010 = 30, p0970). When the power unit use is changed, short-term communication interruptions may occur.		
Note:	When the parameter is changed, all of the motor parameters (p0305 ... p0311), the technological application (p0500) and the control mode (p1300) are pre-assigned according to the selected application. The parameter has no influence when calculating the thermal overload. p0205 can only be changed to the settings that are saved in the power unit EEPROM.		

r0206[0...4]	Rated power unit power / PU P_{rated}		
	Access level: 2	Calculated: -	Data type: FloatingPoint32
	Can be changed: -	Scaling: -	Dyn. index: -
	Unit group: 14_6	Unit selection: p0100	Func. diagram: -
	Min	Max	Factory setting
	- [kW]	- [kW]	- [kW]
Description:	Displays the rated power unit power for various load duty cycles.		
Index:	[0] = Rated value [1] = Load duty cycle with low overload [2] = Load duty cycle with high overload [3] = S1 cont duty cyc [4] = S6 load duty cycle		
Dependency:	IECdrives (p0100 = 0): Units kW NEMA drives (p0100 = 1): Units hp Refer to: p0100, p0205		

r0207[0...4]	Rated power unit current / PU PI_{rated}		
	Access level: 3	Calculated: -	Data type: FloatingPoint32
	Can be changed: -	Scaling: -	Dyn. index: -
	Unit group: -	Unit selection: -	Func. diagram: 8021
	Min	Max	Factory setting
	- [Arms]	- [Arms]	- [Arms]
Description:	Displays the rated power unit power for various load duty cycles.		
Index:	[0] = Rated value [1] = Load duty cycle with low overload [2] = Load duty cycle with high overload [3] = S1 cont duty cyc [4] = S6 load duty cycle		
Dependency:	Refer to: p0205		

r0208	Rated power unit line supply voltage / PU U_{rated}		
	Access level: 2	Calculated: -	Data type: FloatingPoint32
	Can be changed: -	Scaling: -	Dyn. index: -
	Unit group: -	Unit selection: -	Func. diagram: -
	Min	Max	Factory setting
	- [Vrms]	- [Vrms]	- [Vrms]
Description:	Displays the rated line supply voltage of the power unit. r0208 = 400: 380 - 480 V +/-10 % r0208 = 500: 500 - 600 V +/-10 % r0208 = 690: 660 - 690 V +/-10 %		
r0209[0...4]	Power unit maximum current / PU I_{max}		
	Access level: 3	Calculated: -	Data type: FloatingPoint32
	Can be changed: -	Scaling: -	Dyn. index: -
	Unit group: -	Unit selection: -	Func. diagram: -
	Min	Max	Factory setting
	- [Arms]	- [Arms]	- [Arms]
Description:	Displays the maximum output current of the power unit.		
Index:	[0] = Catalog [1] = Load duty cycle with low overload [2] = Load duty cycle with high overload [3] = S1 load duty cycle [4] = S6 load duty cycle		
Dependency:	Refer to: p0205		
p0210	Drive unit line supply voltage / U_{connect}		
	Access level: 3	Calculated: -	Data type: Unsigned16
	Can be changed: T	Scaling: -	Dyn. index: -
	Unit group: -	Unit selection: -	Func. diagram: -
	Min	Max	Factory setting
	1 [V]	63000 [V]	400 [V]
Description:	Sets the drive unit supply voltage (rms value of the phase-to-phase line supply voltage).		
Dependency:	Set p1254, p1294 (automatic detection of the Vdc switch-on levels) = 0. The switch-in thresholds of the Vdc_max controller (r1242, r1282) are then directly determined using p0210.		
Notice:	If, in the switched-off state (pulse inhibit), the supply voltage is higher than the entered value, the Vdc controller may be automatically deactivated in some cases to prevent the motor from accelerating the next time the system is switched on. In this case, an appropriate alarm A07401 is output.		
Note:	Setting ranges for p0210 as a function of the rated power unit voltage: U _{rated} = 230 V: - p0210 = 200 ... 240 V U _{rated} = 400 V: - p0210 = 380 ... 480 V U _{rated} = 690 V: - p0210 = 500 ... 690 V		
p0212	Power unit configuration / PU config		
	Access level: 3	Calculated: -	Data type: Unsigned16
	Can be changed: C(2)	Scaling: -	Dyn. index: -
	Unit group: -	Unit selection: -	Func. diagram: -
	Min	Max	Factory setting
	-	-	0000 0000 0000 0000 bin
Description:	Sets the power unit configuration.		

2 Parameters

2.2 List of parameters

Bit field:	Bit	Signal name	1 signal	0 signal	FP
	07	Reserved	Yes	No	-
	08	Reduction of the activation threshold of the braking chopper	Yes	No	-

Dependency: Refer to: p0210

Caution: For bit 08 = 1:



Damage to the device if p0210 is parameterized too low

An excessively low supply voltage set in p0210 means that the braking resistor is permanently controlled, although the converter is not in the braking mode. As a consequence, the braking resistor can be thermally overloaded.

- Do not parameterize p0210 with values that fall below the actual line voltage by more than 10 %.

Damage to the motor p0210 is parameterized too high

The motor insulation could be damaged when braking if excessively high values are entered. This is especially the case for motors that are designed for a 500 V line voltage and for motors from third parties.

- Do not parameterize p0210 with values that exceed the actual line voltage by more than 10 %.

Note: For bit 07:

Only for internal Siemens use

For bit 08 = 1:

The activation threshold of the braking chopper (referred to the DC link voltage) is reduced as a function of p0210.

The shutdown threshold is also reduced as a result of a DC link overvoltage (r0297).

p0219	Braking resistor braking power / R_brake P_brake		
Access level: 3	Calculated: -	Data type: FloatingPoint32	
Can be changed: C(1), T	Scaling: -	Dyn. index: -	
Unit group: 14_6	Unit selection: p0100	Func. diagram: -	
Min	Max	Factory setting	
0.00 [kW]	20000.00 [kW]	0.00 [kW]	
Description:	Sets the braking power of the connected braking resistor.		
Dependency:	Refer to: p1127, p1240, p1280, p1531		
Note:	When setting a value for the braking power, the following calculations are made:		
	- p1240, p1280: Vdc_max control is deactivated.		
	- p1531 = - p0219: the power limit when generating is set (limited to - p1530).		
	- the minimum ramp-down time is calculated (p1127) as a function of p0341, p0342 and p1082 (not for vector control with speed encoder).		
	If the parameter is reset again to zero, then the Vdc_max controller is reactivated and the power limit as well as the ramp-down time are recalculated.		
	The parameters are preassigned according to the specific power unit once the Control Unit has been powered up for the first time or when the factory settings have been restored.		

r0238	Internal power unit resistance / PU R internal		
Access level: 3	Calculated: -	Data type: FloatingPoint32	
Can be changed: -	Scaling: -	Dyn. index: -	
Unit group: -	Unit selection: -	Func. diagram: -	
Min	Max	Factory setting	
- [ohm]	- [ohm]	- [ohm]	
Description:	Displays the internal resistance of the power unit (IGBT and line resistance).		

p0251[0...n]	Operating hours counter power unit fan / PU fan t_oper		
Access level: 3	Calculated: -	Data type: Unsigned32	
Can be changed: T	Scaling: -	Dyn. index: -	
Unit group: -	Unit selection: -	Func. diagram: -	
Min	Max	Factory setting	
0 [h]	4294967295 [h]	0 [h]	
Description:	Displays the power unit fan operating hours.		
	The number of hours operated can only be reset to 0 in this parameter (e.g. after a fan has been replaced).		
Dependency:	Refer to: A30042		

Note: For liquid-cooled chassis power units, the operating hours of the inner fan are displayed in p0251 and not in p0254.

p0287[0...1]	Ground fault monitoring thresholds / Gnd flt threshold		
	Access level: 3	Calculated: -	Data type: FloatingPoint32
	Can be changed: T	Scaling: -	Dyn. index: -
	Unit group: -	Unit selection: -	Func. diagram: -
	Min	Max	Factory setting
	0.0 [%]	100.0 [%]	[0] 6.0 [%] [1] 16.0 [%]

Description: Sets the shutdown thresholds for the ground fault monitoring.
The setting is made as a percentage of the maximum current of the power unit (r0209).

Index: [0] = Threshold at which precharging starts
[1] = Threshold at which precharging stops

Dependency: Refer to: p1901
Refer to: F30021

Note: This parameter is only relevant for chassis power units.

r0289	CO: Maximum power unit output current / PU I_outp max		
	Access level: 3	Calculated: -	Data type: FloatingPoint32
	Can be changed: -	Scaling: p2002	Dyn. index: -
	Unit group: -	Unit selection: -	Func. diagram: -
	Min	Max	Factory setting
	- [Arms]	- [Arms]	- [Arms]

Description: Displays the actual maximum output current of the power unit taking into account derating factors.

p0290	Power unit overload response / PU overlD response		
	Access level: 3	Calculated: -	Data type: Integer16
	Can be changed: T	Scaling: -	Dyn. index: -
	Unit group: -	Unit selection: -	Func. diagram: 8021
	Min	Max	Factory setting
	0	13	13

Description: Sets the response to a thermal overload condition of the power unit.
The following quantities can result in a response to thermal overload:
- heat sink temperature (r0037[0]).
- chip temperature (r0037[1]).
- power unit overload I2t (r0036).
Possible measures to avoid thermal overload:
- reduce the output current limit r0289 and r0067 (for closed-loop speed or torque control) or the output frequency (for U/f control indirectly via the output current limit and the intervention of the current limiting controller).
- reduce the pulse frequency.

A reduction, if parameterized, is always realized after an appropriate alarm is output.

Value: 0: Reduce output current or output frequency
1: No reduction shutdown when overload threshold is reached
2: Reduce I_output or f_output and f_pulse (not using I2t)
3: Reduce the pulse frequency (not using I2t)
12: I_output or f_output and automatic pulse frequency reduction
13: Automatic pulse frequency reduction

Dependency: If a sine-wave filter is parameterized as output filter (p0230 = 3, 4), then only responses can be selected without pulse frequency reduction (p0290 = 0, 1).

For a thermal power unit overload, an appropriate alarm or fault is output, and r2135.15 or r2135.13 set.

Refer to: r0036, r0037, r2135

Refer to: A05000, A05001, A07805

Notice: If the thermal overload of the power unit is not sufficiently reduced by the actions taken, the drive is always shut down. This means that the power unit is always protected irrespective of the setting of this parameter.

2 Parameters

2.2 List of parameters

Note: The setting p0290 = 0, 2 is only practical if the load decreases with decreasing speed (e.g. for applications with variable torque such as for pumps and fans).
Under overload conditions, the current and torque limit are reduced, and therefore the motor is braked and forbidden speed ranges (e.g. minimum speed p1080 and suppression [skip] speeds p1091 ... p1094) can be passed through.
For p0290 = 2, 3, 12, 13, the I2t overload detection of the power unit does not influence the response "Reduce pulse frequency".
When the motor data identification routine is selected, p0290 cannot be changed.
For short-circuit/ground fault detection, when the test pulse evaluation is active via p1901 "Test pulse evaluation configuration", the pulse frequency at the instant of switch on is briefly reduced.

p0292[0...1]	Power unit temperature alarm threshold / PU T_alm thresh		
Access level: 3	Calculated: -	Data type: FloatingPoint32	
Can be changed: U, T	Scaling: -	Dyn. index: -	
Unit group: -	Unit selection: -	Func. diagram: 8021	
Min	Max	Factory setting	
0 [°C]	25 [°C]	[0] 5 [°C] [1] 15 [°C]	
Description:	Sets the alarm threshold for power unit overtemperatures. The value is set as a difference to the tripping (shutdown) temperature. Drive: If this threshold is exceeded, an overload alarm is generated and the system responds as parameterized in p0290. Infeed: When the threshold value is exceeded, only an overload alarm is output.		
Index:	[0] = Overtemperature heat sink [1] = Temperature rise power semiconductor (chip)		
Dependency:	Refer to: r0037, p0290 Refer to: A05000, A05001		

p0294	Power unit alarm with I2t overload / PU I2t alm thresh		
Access level: 4	Calculated: -	Data type: FloatingPoint32	
Can be changed: U, T	Scaling: -	Dyn. index: -	
Unit group: -	Unit selection: -	Func. diagram: 8021	
Min	Max	Factory setting	
10.0 [%]	100.0 [%]	95.0 [%]	
Description:	Sets the alarm threshold for the I2t power unit overload. If this threshold is exceeded, an overload alarm is generated and the system responds as parameterized in p0290.		
Dependency:	Refer to: r0036, p0290 Refer to: A07805		
Note:	The I2t fault threshold is 100 %. If this value is exceeded, fault F30005 is output.		

r0296	DC link voltage undervoltage threshold / Vdc U_lower_thresh		
Access level: 3	Calculated: -	Data type: Unsigned16	
Can be changed: -	Scaling: -	Dyn. index: -	
Unit group: -	Unit selection: -	Func. diagram: -	
Min	Max	Factory setting	
- [V]	- [V]	- [V]	
Description:	Threshold to detect a DC link undervoltage. If the DC link voltage falls below this threshold, the drive unit is tripped due to a DC link undervoltage condition.		
Dependency:	Refer to: F30003		

r0297	DC link voltage overvoltage threshold / Vdc U_upper_thresh		
	Access level: 3	Calculated: -	Data type: Unsigned16
	Can be changed: -	Scaling: -	Dyn. index: -
	Unit group: -	Unit selection: -	Func. diagram: -
	Min	Max	Factory setting
	- [V]	- [V]	- [V]
Description:	Threshold to detect a DC link overvoltage. If the DC link voltage exceeds the threshold specified here, the drive unit is tripped due to DC link overvoltage.		
Dependency:	Refer to: F30002		
p0300[0...n]	Motor type selection / Mot type sel		
	Access level: 2	Calculated: -	Data type: Integer16
	Can be changed: C(1, 3)	Scaling: -	Dyn. index: DDS, p0180
	Unit group: -	Unit selection: -	Func. diagram: 6310
	Min	Max	Factory setting
	0	603	0
Description:	Selecting the motor type. The first digit of the parameter value always defines the general motor type and corresponds to the third-party motor belonging to a motor list: 1 = induction motor 2 = synchronous motor 6 = synchronous reluctance motor xx = motor without code number xxx = motor with code number The following applies for values < 100: Motor data must be manually entered. The following applies for values >= 100: Motor data are automatically loaded from an internal list.		
Value:	0: No motor 1: Induction motor 2: Synchronous motor 6: Reluctance motor 10: 1LE1 induction motor (not a code number) 13: 1LG6 induction motor (not a code number) 17: 1LA7 induction motor (not a code number) 19: 1LA9 induction motor (not a code number) 100: 1LE1 induction motor 101: 1PC1 induction motor 181: 2KJ8 induction motor 600: 1FP1 synchronous reluctance motor 602: 2KJ8 synchronous reluctance motor 603: 1FP3 synchronous reluctance motor OEM		
Dependency:	When selecting p0300 = 10 ... 19, parameters p0335, p0626, p0627, and p0628 of the thermal motor model are pre-assigned as a function of p0307 and p0311.		
Caution:	If a motor is selected, which is not contained in the motor lists (p0300 < 100), then the motor code number must be reset (p0301 = 0), if previously a motor was parameterized from the motor list.		
			
Notice:	If a catalog motor is selected (p0300 >= 100) and an associated motor code number (p0301), then the parameters that are associated with this list cannot be changed (write protection). The write protection is canceled if the motor type p0300 is set to a non-Siemens motor that matches p0301 (e.g. p0300 = 1 for p0301 = 1xxxx). Write protection is automatically canceled when the results of motor data identification are copied to the motor parameters. The motor type of a catalog motor corresponds to the upper three digits of the code number or the following assignment (if the particular motor type is listed): Type/code number ranges 100 / 100xx, 110xx, 120xx, 130xx, 140xx, 150xx		

2 Parameters

2.2 List of parameters

Note: Once the Control Unit has been powered up for the first time or for the factory settings, the motor type is automatically preassigned.
If a motor type has not been selected (p0300 = 0), then the drive commissioning routine cannot be exited.
A motor type with a value above p0300 \geq 100 describes motors for which a motor parameter list exists.

p0301[0...n]	Motor code number selection / Mot code No. sel		
	Access level: 2	Calculated: -	Data type: Unsigned16
	Can be changed: C(1, 3)	Scaling: -	Dyn. index: DDS, p0180
	Unit group: -	Unit selection: -	Func. diagram: -
	Min	Max	Factory setting
	0	65535	0
Description:	The parameter is used to select a motor from a motor parameter list. When changing the code number (with the exception to the value 0), all of the motor parameters are pre-assigned from the internally available parameter lists.		
Dependency:	Code numbers can only be selected for motor types that correspond to the motor type selected in p0300. Refer to: p0300		
Note:	The motor code number can only be changed if the matching catalog motor was first selected in p0300. When selecting a catalog motor (p0300 \geq 100), drive commissioning can only be exited if a code number is selected. If a change is made to a non-catalog motor, then the motor code number should be reset (p0301 = 0).		

p0304[0...n]	Rated motor voltage / Mot U_{rated}		
	Access level: 1	Calculated: -	Data type: FloatingPoint32
	Can be changed: C(1, 3)	Scaling: -	Dyn. index: DDS, p0180
	Unit group: -	Unit selection: -	Func. diagram: 6301, 6724
	Min	Max	Factory setting
	0 [Vrms]	20000 [Vrms]	0 [Vrms]
Description:	Sets the rated motor voltage (rating plate).		
Notice:	When selecting a catalog motor (p0301), this parameter is automatically pre-assigned and is write protected. Information in p0300 should be carefully observed when removing write protection.		
Note:	When the parameter value is entered the connection type of the motor (star-delta) must be taken into account. Once the Control Unit has booted for the first time or if the factory settings have been restored, the parameter is pre-assigned to match the power unit.		

p0305[0...n]	Rated motor current / Mot I_{rated}		
	Access level: 1	Calculated: -	Data type: FloatingPoint32
	Can be changed: C(1, 3)	Scaling: -	Dyn. index: DDS, p0180
	Unit group: -	Unit selection: -	Func. diagram: 6301
	Min	Max	Factory setting
	0.00 [Arms]	10000.00 [Arms]	0.00 [Arms]
Description:	Sets the rated motor current (rating plate).		
Notice:	When selecting a catalog motor (p0301), this parameter is automatically pre-assigned and is write protected. Information in p0300 should be carefully observed when removing write protection. If p0305 is changed during quick commissioning (p0010 = 1), then the maximum current p0640 is pre-assigned accordingly.		
Note:	When the parameter value is entered the connection type of the motor (star-delta) must be taken into account. Once the Control Unit has booted for the first time or if the factory settings have been restored, the parameter is pre-assigned to match the power unit.		

p0307[0...n]	Rated motor power / Mot P_{rated}		
	Access level: 1	Calculated: -	Data type: FloatingPoint32
	Can be changed: C(1, 3)	Scaling: -	Dyn. index: DDS, p0180
	Unit group: 14_6	Unit selection: p0100	Func. diagram: -
	Min	Max	Factory setting
	0.00 [kW]	100000.00 [kW]	0.00 [kW]
Description:	Sets the rated motor power (rating plate).		
Dependency:	IECdrives (p0100 = 0): Units kW NEMA drives (p0100 = 1): Units hp NEMA drives (p0100 = 2): Unit kW Refer to: p0100		
Notice:	When selecting a catalog motor (p0301), this parameter is automatically pre-assigned and is write protected. Information in p0300 should be carefully observed when removing write protection.		
Note:	Once the Control Unit has booted for the first time or if the factory settings have been restored, the parameter is pre-assigned to match the power unit.		
p0308[0...n]	Rated motor power factor / Mot cos phi rated		
	Access level: 1	Calculated: -	Data type: FloatingPoint32
	Can be changed: C(1, 3)	Scaling: -	Dyn. index: DDS, p0180
	Unit group: -	Unit selection: -	Func. diagram: -
	Min	Max	Factory setting
	0.000	1.000	0.000
Description:	Sets the rated motor power factor (cos phi, rating plate). For a parameter value of 0.000, the power factor is internally calculated and displayed in r0332.		
Dependency:	This parameter is only available for p0100 = 0, 2. Refer to: p0100, p0309, r0332		
Notice:	When selecting a catalog motor (p0301), this parameter is automatically pre-assigned and is write protected. Information in p0300 should be carefully observed when removing write protection.		
Note:	The parameter is not used for synchronous motors (p0300 = 2xx). Once the Control Unit has booted for the first time or if the factory settings have been restored, the parameter is pre-assigned to match the power unit.		
p0309[0...n]	Rated motor efficiency / Mot eta_{rated}		
	Access level: 1	Calculated: -	Data type: FloatingPoint32
	Can be changed: C(1, 3)	Scaling: -	Dyn. index: DDS, p0180
	Unit group: -	Unit selection: -	Func. diagram: -
	Min	Max	Factory setting
	0.0 [%]	99.9 [%]	0.0 [%]
Description:	Sets the rated motor efficiency (rating plate). For a parameter value of 0.0, the power factor is internally calculated and displayed in r0332.		
Dependency:	This parameter is only visible for NEMA motors (p0100 = 1, 2). Refer to: p0100, p0308, r0332		
Note:	The parameter is not used for synchronous motors.		
p0310[0...n]	Rated motor frequency / Mot f_{rated}		
	Access level: 1	Calculated: -	Data type: FloatingPoint32
	Can be changed: C(1, 3)	Scaling: -	Dyn. index: DDS, p0180
	Unit group: -	Unit selection: -	Func. diagram: 6301
	Min	Max	Factory setting
	0.00 [Hz]	650.00 [Hz]	0.00 [Hz]
Description:	Sets the rated motor frequency (rating plate).		

2 Parameters

2.2 List of parameters

Dependency:	The number of pole pairs (r0313) is automatically re-calculated when the parameter is changed (together with p0311), if p0314 = 0. The rated frequency is restricted to values between 1.00 Hz and 650.00 Hz. Refer to: p0311, r0313, p0314
Notice:	When selecting a catalog motor (p0301), this parameter is automatically pre-assigned and is write protected. Information in p0300 should be carefully observed when removing write protection. If p0310 is changed during quick commissioning (p0010 = 1), the maximum speed p1082, which is also associated with quick commissioning, is pre-assigned accordingly. The pre-assignment has been completed if the status display r3996 returns to zero.
Note:	The parameters are preassigned according to the specific power unit once the Control Unit has been powered up for the first time or when the factory settings have been restored.

p0311[0...n]

Rated motor speed / Mot n_{rated}

Access level: 1	Calculated: -	Data type: FloatingPoint32
Can be changed: C(1, 3)	Scaling: -	Dyn. index: DDS, p0180
Unit group: -	Unit selection: -	Func. diagram: -
Min	Max	Factory setting
0.0 [rpm]	210000.0 [rpm]	0.0 [rpm]

Description:	Sets the rated motor speed (rating plate). For p0311 = 0, the rated motor slip of induction motors is internally calculated and displayed in r0330. It is especially important to correctly enter the rated motor speed for vector control and slip compensation for U/f control.
Dependency:	If p0311 is changed and for p0314 = 0, the pole pair (r0313) is re-calculated automatically. Refer to: p0310, r0313, p0314
Notice:	When selecting a catalog motor (p0301), this parameter is automatically pre-assigned and is write protected. Information in p0300 should be carefully observed when removing write protection. If p0311 is changed during quick commissioning (p0010 = 1), the maximum speed p1082, which is also associated with quick commissioning, is pre-assigned accordingly. The pre-assignment has been completed if the status display r3996 returns to zero.
Note:	The parameters are preassigned according to the specific power unit once the Control Unit has been powered up for the first time or when the factory settings have been restored.

r0313[0...n]

Motor pole pair number, actual (or calculated) / Mot PolePairNo act

Access level: 3	Calculated: -	Data type: Unsigned16
Can be changed: -	Scaling: -	Dyn. index: DDS, p0180
Unit group: -	Unit selection: -	Func. diagram: 5300
Min	Max	Factory setting
-	-	-

Description:	Displays the number of motor pole pairs. The value is used for internal calculations. r0313 = 1: 2-pole motor r0313 = 2: 4-pole motor, etc.
Dependency:	For p0314 > 0, the entered value is displayed in r0313. For p0314 = 0, the pole pair number (r0313) is automatically calculated from the rated power (p0307), rated frequency (p0310) and rated speed (p0311). Refer to: p0307, p0310, p0311, p0314
Note:	For the automatic calculation, the pole pair number is set to the value of 2 if the rated speed or the rated frequency is zero.

p0314[0...n]	Motor pole pair number / Mot pole pair No.		
	Access level: 3	Calculated: -	Data type: Unsigned16
	Can be changed: C(1, 3)	Scaling: -	Dyn. index: DDS, p0180
	Unit group: -	Unit selection: -	Func. diagram: -
	Min	Max	Factory setting
	0	255	0
Description:	Sets the motor pole pair number. p0314 = 1: 2-pole motor p0314 = 2: 4-pole motor, etc.		
Dependency:	For p0314 = 0, the pole pair number is automatically calculated from the rated frequency (p0310) and the rated speed (p0311) and displayed in r0313.		
Notice:	If p0314 is changed during quick commissioning (p0010 = 1), the maximum speed p1082, which is also associated with quick commissioning, is pre-assigned accordingly. For induction motors, it is only necessary to enter the value if the rated motor slip is so high that the pole pair number r0313, obtained when making the calculation based on the rated frequency and rated speed, is too low.		
p0316[0...n]	Motor torque constant / Mot kT		
	Access level: 3	Calculated: -	Data type: FloatingPoint32
	Can be changed: C(1), U, T	Scaling: -	Dyn. index: DDS, p0180
	Unit group: 28_1	Unit selection: p0100	Func. diagram: -
	Min	Max	Factory setting
	0.00 [Nm/A]	400.00 [Nm/A]	0.00 [Nm/A]
Description:	Sets the torque constant of the synchronous motor. p0316 = 0: The torque constant is calculated from the motor data. p0316 > 0: The selected value is used as torque constant.		
Dependency:	Refer to: r0334		
Notice:	When selecting a catalog motor (p0301), this parameter is automatically pre-assigned and is write protected. Information in p0300 should be carefully observed when removing write protection.		
Note:	This parameter is not used for induction motors (p0300 = 1xx).		
p0318[0...n]	Motor stall current / Mot I_standstill		
	Access level: 3	Calculated: -	Data type: FloatingPoint32
	Can be changed: C(3)	Scaling: -	Dyn. index: DDS, p0180
	Unit group: -	Unit selection: -	Func. diagram: 8017
	Min	Max	Factory setting
	0.00 [Arms]	10000.00 [Arms]	0.00 [Arms]
Description:	Sets the stall current for synchronous motors (p0300 = 2xx).		
Notice:	When selecting a catalog motor (p0301), this parameter is automatically pre-assigned and is write protected. Information in p0300 should be carefully observed when removing write protection.		
Note:	The parameter is used for the I2t monitoring of the motor (refer to p0611). This parameter is not used for induction motors (p0300 = 1xx).		

p0320[0...n]	Motor rated magnetizing current/short-circuit current / Mot I_mag_rated		
	Access level: 3	Calculated: -	Data type: FloatingPoint32
	Can be changed: U, T	Scaling: -	Dyn. index: DDS, p0180
	Unit group: -	Unit selection: -	Func. diagram: -
	Min	Max	Factory setting
	0.000 [Arms]	5000.000 [Arms]	0.000 [Arms]
Description:	Induction motors: Sets the rated motor magnetizing current. For p0320 = 0.000 the magnetizing current is internally calculated and displayed in r0331. Synchronous motors: Sets the rated motor short-circuit current.		
Notice:	When selecting a catalog motor (p0301), this parameter is automatically pre-assigned and is write protected. Information in p0300 should be carefully observed when removing write protection.		
Note:	The magnetizing current p0320 for induction motors is reset when quick commissioning is exited with p3900 > 0. If, for induction motors, the magnetizing current p0320 is changed outside the commissioning phase (p0010 > 0), then the magnetizing inductance p0360 is changed so that the EMF r0337 remains constant.		
p0322[0...n]	Maximum motor speed / Mot n_max		
	Access level: 1	Calculated: -	Data type: FloatingPoint32
	Can be changed: C(1, 3)	Scaling: -	Dyn. index: DDS, p0180
	Unit group: -	Unit selection: -	Func. diagram: -
	Min	Max	Factory setting
	0.0 [rpm]	210000.0 [rpm]	0.0 [rpm]
Description:	Sets the maximum motor speed.		
Dependency:	Refer to: p1082		
Notice:	When selecting a catalog motor (p0301), this parameter is automatically pre-assigned and is write protected. Information in p0300 should be carefully observed when removing write protection.		
	If p0322 is changed during quick commissioning (p0010 = 1), the maximum speed p1082, which is also associated with quick commissioning, is pre-assigned accordingly.		
Note:	The parameter has no significance for a value of p0322 = 0.		
p0323[0...n]	Maximum motor current / Mot I_max		
	Access level: 3	Calculated: -	Data type: FloatingPoint32
	Can be changed: C(1, 3)	Scaling: -	Dyn. index: DDS, p0180
	Unit group: -	Unit selection: -	Func. diagram: -
	Min	Max	Factory setting
	0.00 [Arms]	20000.00 [Arms]	0.00 [Arms]
Description:	Sets the maximum permissible motor current (e.g. de-magnetizing current for synchronous motors).		
Notice:	When selecting a catalog motor (p0301), this parameter is automatically pre-assigned and is write protected. Information in p0300 should be carefully observed when removing write protection.		
	If p0323 is changed during quick commissioning (p0010 = 1), then the maximum current p0640 is pre-assigned accordingly. This is not the case when commissioning the motor (p0010 = 3).		
Note:	The parameter has no effect for induction motors. For synchronous motors, a value must always be entered for the maximum motor current. p0323 is a motor data. The user-selectable current limit is entered into p0640.		

p0325[0...n]	Motor pole position identification current 1st phase / Mot PolID I 1st Ph		
	Access level: 3	Calculated: -	Data type: FloatingPoint32
	Can be changed: U, T	Scaling: -	Dyn. index: DDS, p0180
	Unit group: -	Unit selection: -	Func. diagram: -
	Min	Max	Factory setting
	0.000 [Arms]	10000.000 [Arms]	0.000 [Arms]
Description:	Sets the current for the 1st phase of the two-stage technique for pole position identification routine. The current of the 2nd phase is set in p0329. The two-stage technique is selected with p1980 = 4.		
Dependency:	Refer to: p0329, p1980, r1984, r1985, r1987, r1992		
Notice:	When the motor code (p0301) is changed, it is possible that p0325 is not pre-assigned. p0325 can be pre-assigned using p0340 = 3.		
Note:	The value is automatically pre-assigned for the following events: - For p0325 = 0 and automatic calculation of the closed-loop control parameters (p0340 = 1, 2, 3). - for quick commissioning (p3900 = 1, 2, 3).		
p0326[0...n]	Motor stall torque correction factor / Mot M_stall_corr		
	Access level: 4	Calculated: -	Data type: FloatingPoint32
	Can be changed: U, T	Scaling: -	Dyn. index: DDS, p0180
	Unit group: -	Unit selection: -	Func. diagram: -
	Min	Max	Factory setting
	5 [%]	300 [%]	100 [%]
Description:	Sets the correction factor for the stall torque/force at a 600 V DC link voltage.		
Notice:	When selecting a catalog motor (p0301), this parameter is automatically pre-assigned and is write protected. Information in p0300 should be carefully observed when removing write protection.		
Note:	When quick commissioning is exited with p3900 > 0, then the parameter is reset if a catalog motor has not been selected (p0300).		
p0327[0...n]	Optimum motor load angle / Mot phi_load opt		
	Access level: 3	Calculated: -	Data type: FloatingPoint32
	Can be changed: U, T	Scaling: -	Dyn. index: DDS, p0180
	Unit group: -	Unit selection: -	Func. diagram: 5722, 6721
	Min	Max	Factory setting
	0.0 [°]	135.0 [°]	90.0 [°]
Description:	Sets the optimum load angle for synchronous motors with reluctance torque (e.g. 1FE motors). The load angle is measured at the rated motor current.		
Notice:	When selecting a catalog motor (p0301), this parameter is automatically pre-assigned and is write protected. Information in p0300 should be carefully observed when removing write protection.		
Note:	This parameter has no significance for induction motors. For synchronous motors without reluctance torque, a angle of 90 degrees must be set. When quick commissioning is exited with p3900 > 0, then the parameter is reset if a catalog motor has not been selected (p0300).		
p0328[0...n]	Motor reluctance torque constant / Mot kT_reluctance		
	Access level: 3	Calculated: -	Data type: FloatingPoint32
	Can be changed: U, T	Scaling: -	Dyn. index: DDS, p0180
	Unit group: -	Unit selection: -	Func. diagram: -
	Min	Max	Factory setting
	-1000.00 [mH]	1000.00 [mH]	0.00 [mH]
Description:	Sets the reluctance torque constant for synchronous motors with reluctance torque (e.g. 1FE ... motors). This parameter has no significance for induction motors.		
Notice:	When selecting a catalog motor (p0301), this parameter is automatically pre-assigned and is write protected. Information in p0300 should be carefully observed when removing write protection.		

Note: For synchronous motors without reluctance torque, the value 0 must be set.

p0329[0...n]	Motor pole position identification current / Mot PolID current		
	Access level: 3	Calculated: -	Data type: FloatingPoint32
	Can be changed: U, T	Scaling: -	Dyn. index: DDS, p0180
	Unit group: -	Unit selection: -	Func. diagram: -
	Min	Max	Factory setting
	0.0000 [Arms]	10000.0000 [Arms]	0.0000 [Arms]
Description:	Sets the current for the pole position identification routine (p1980 = 1). For a two-stage technique (p1980 = 4), the current is set for the 2nd phase. The current for the 1st phase is set in p0325.		
Dependency:	The following applies for vector drives: If a maximum current (p0323) was not parameterized, then p0329 is limited to the rated motor current. Refer to: p0325, p1980, r1984, r1985, r1987, r1992		
Notice:	When selecting a catalog motor (p0301), this parameter is automatically pre-assigned and is write protected. Information in p0300 should be carefully observed when removing write protection.		

r0330[0...n]	Rated motor slip / Mot slip_rated		
	Access level: 3	Calculated: -	Data type: FloatingPoint32
	Can be changed: -	Scaling: -	Dyn. index: DDS, p0180
	Unit group: -	Unit selection: -	Func. diagram: -
	Min	Max	Factory setting
	- [Hz]	- [Hz]	- [Hz]
Description:	Displays the rated motor slip.		
Dependency:	The rated slip is calculated from the rated frequency, rated speed and number of pole pairs. Refer to: p0310, p0311, r0313		

r0331[0...n]	Actual motor magnetizing current/short-circuit current / Mot I_mag_rtd act		
	Access level: 3	Calculated: -	Data type: FloatingPoint32
	Can be changed: -	Scaling: -	Dyn. index: DDS, p0180
	Unit group: -	Unit selection: -	Func. diagram: 6722, 6724
	Min	Max	Factory setting
	- [Arms]	- [Arms]	- [Arms]
Description:	Induction motor: Displays the rated magnetizing current from p0320. For p0320 = 0, the internally calculated magnetizing current is displayed. Synchronous motor: Displays the rated short-circuit current from p0320.		
Dependency:	If p0320 was not entered, then the parameter is calculated from the rating plate parameters.		

r0332[0...n]	Rated motor power factor / Mot cos phi rated		
	Access level: 3	Calculated: -	Data type: FloatingPoint32
	Can be changed: -	Scaling: -	Dyn. index: DDS, p0180
	Unit group: -	Unit selection: -	Func. diagram: -
	Min	Max	Factory setting
	-	-	-
Description:	Displays the rated power factor for induction motors. For IEC motors, the following applies (p0100 = 0): For p0308 = 0, the internally calculated power factor is displayed. For p0308 > 0, this value is displayed. For NEMA motors, the following applies (p0100 = 1, 2): For p0309 = 0, the internally calculated power factor is displayed. For p0309 > 0, this value is converted into the power factor and displayed.		

Dependency: If p0308 is not entered, the parameter is calculated from the rating plate parameters.

r0333[0...n]	Rated motor torque / Mot M_{rated}		
	Access level: 3	Calculated: -	Data type: FloatingPoint32
	Can be changed: -	Scaling: -	Dyn. index: DDS, p0180
	Unit group: 7_4	Unit selection: p0100	Func. diagram: -
	Min	Max	Factory setting
	- [Nm]	- [Nm]	- [Nm]
Description:	Displays the rated motor torque.		
Dependency:	IEC drives (p0100 = 0): unit Nm NEMA drives (p0100 = 1): unit lbf ft		
Note:	For induction motors, r0333 is calculated from p0307 and p0311. For synchronous motors, r0333 is calculated from p0305, p0316, p0327 and p0328.		

r0334[0...n]	Actual motor-torque constant / Mot kT_{act}		
	Access level: 3	Calculated: -	Data type: FloatingPoint32
	Can be changed: -	Scaling: -	Dyn. index: DDS, p0180
	Unit group: 28_1	Unit selection: p0100	Func. diagram: -
	Min	Max	Factory setting
	- [Nm/A]	- [Nm/A]	- [Nm/A]
Description:	Displays the torque constant of the synchronous motor used.		
Dependency:	IEC drives (p0100 = 0): unit Nm / A NEMA drives (p0100 = 1): unit lbf ft / A Refer to: p0316		
Note:	This parameter is not used for induction motors (p0300 = 1xx). For synchronous motors, parameter r0334 = p0316 is displayed. For p0316 = 0, r0334 is calculated from p0305 and p0312 or p0305, p0307, and p0311.		

p0335[0...n]	Motor cooling type / Mot cool type		
	Access level: 2	Calculated: -	Data type: Integer16
	Can be changed: C(1), T	Scaling: -	Dyn. index: DDS, p0180
	Unit group: -	Unit selection: -	Func. diagram: -
	Min	Max	Factory setting
	0	128	0
Description:	Sets the motor cooling system used.		
Value:	0: Natural ventilation 1: Forced cooling 2: Liquid cooling 128: No fan		
Dependency:	For 1LA7 motors (p0300), the parameter is pre-set as a function of p0307 and p0311.		
Notice:	When selecting a catalog motor (p0301), this parameter is automatically pre-assigned and is write protected. Information in p0300 should be carefully observed when removing write protection.		
Note:	The parameter influences the thermal 3-mass motor model. 1LA7 motors, frame size 56 are operated without fan.		

r0337[0...n]	Rated motor EMF / Mot EMF_{rated}		
	Access level: 4	Calculated: -	Data type: FloatingPoint32
	Can be changed: -	Scaling: -	Dyn. index: DDS, p0180
	Unit group: -	Unit selection: -	Func. diagram: -
	Min	Max	Factory setting
	- [Vrms]	- [Vrms]	- [Vrms]
Description:	Displays the rated EMF of the motor.		
Note:	EMF: Electromotive force		

p0340[0...n]	Automatic calculation motor/control parameters / Calc auto par		
	Access level: 2	Calculated: -	Data type: Integer16
	Can be changed: T	Scaling: -	Dyn. index: DDS, p0180
	Unit group: -	Unit selection: -	Func. diagram: -
	Min	Max	Factory setting
	0	5	0
Description:	Setting to automatically calculate motor parameters and U/f open-loop and closed-loop control parameters from the rating plate data.		
Value:	0: No calculation 1: Complete calculation 2: Calculation of equivalent circuit diagram parameters 3: Calculation of closed-loop control parameters 4: Calculation of controller parameters 5: Calculation of technological limits and threshold values		
Notice:	After the value has been modified, no further parameter modifications can be made and the status is shown in r3996. Modifications can be made again when r3996 = 0. The following parameters are influenced using p0340: p0340 = 1: --> All of the parameters influenced for p0340 = 2, 3, 4, 5 --> p0341, p0342, p0344, p0612, p0640, p1082, p1231, p1232, p1333, p1349, p1611, p1654, p1726, p1825, p1828 ... p1832, p1909, p1959, p2000, p2001, p2002, p2003, p3927, p3928 p0340 = 2: --> p0350, p0354 ... p0360 --> p0625 (matching p0350), p0626 ... p0628 p0340 = 3: --> All of the parameters influenced for p0340 = 4, 5 --> p0346, p0347, p0622, p1320 ... p1327, p1582, p1584, p1616, p1755, p1756, p2178 p0340 = 4: --> p1290, p1292, p1293, p1338, p1339, p1340, p1341, p1345, p1346, p1461, p1463, p1464, p1465, p1470, p1472, p1703, p1715, p1717, p1740, p1756, p1764, p1767, p1780, p1781, p1783, p1785, p1786, p1795 p0340 = 5: --> p1037, p1038, p1520, p1521, p1530, p1531, p1574, p1750, p1759, p1802, p1803, p2140, p2142, p2148, p2150, p2157, p2159, p2161, p2162, p2163, p2164, p2170, p2175, p2177, p2179, p2194 p0340 = 1 contains the calculations of p0340 = 2, 3, 4, 5. p0340 = 2 calculates the motor parameters (p0350 ... p0360). p0340 = 3 contains the calculations of p0340 = 4, 5. p0340 = 4 only calculates the controller parameters. p0340 = 5 only calculates the controller limits. When quick commissioning is exited using p3900 > 0, p0340 is automatically set to 1. At the end of the calculations, p0340 is automatically set to 0.		
Note:			
p0341[0...n]	Motor moment of inertia / Mot M_mom of inert		
	Access level: 3	Calculated: p0340 = 1	Data type: FloatingPoint32
	Can be changed: U, T	Scaling: -	Dyn. index: DDS, p0180
	Unit group: 25_1	Unit selection: p0100	Func. diagram: 6020, 6030, 6031
	Min	Max	Factory setting
	0.000000 [kgm ²]	100000.000000 [kgm ²]	0.000000 [kgm ²]
Description:	Sets the motor moment of inertia (without load).		
Dependency:	IEC drives (p0100 = 0): unit kg m ² NEMA drives (p0100 = 1): unit lb ft ² The parameter value is included, together with p0342, in the rated starting time of the motor. Refer to: p0342, r0345		
Notice:	When selecting a catalog motor (p0301), this parameter is automatically pre-assigned and is write protected. Information in p0300 should be carefully observed when removing write protection.		
Note:	The product of p0341 * p0342 is used when the speed controller (p0340 = 4) is calculated automatically.		

p0342[0...n]	Ratio between the total and motor moment of inertia / Mot MomInert Ratio		
	Access level: 3	Calculated: p0340 = 1	Data type: FloatingPoint32
	Can be changed: U, T	Scaling: -	Dyn. index: DDS, p0180
	Unit group: -	Unit selection: -	Func. diagram: 6020, 6030, 6031
	Min	Max	Factory setting
	1.000	10000.000	1.000
Description:	Sets the ratio between the total moment of inertia/mass (load + motor) and the intrinsic motor moment of inertia/mass (no load).		
Dependency:	This means that together with p0341, the rated starting (accelerating time) of the motor is calculated for a vector drive. Refer to: p0341, r0345		
Note:	The product of p0341 * p0342 is used when the speed controller (p0340 = 4) is calculated automatically.		
r0343[0...n]	Rated motor current identified / Mot I_rated ident		
	Access level: 4	Calculated: -	Data type: FloatingPoint32
	Can be changed: -	Scaling: -	Dyn. index: DDS, p0180
	Unit group: -	Unit selection: -	Func. diagram: -
	Min	Max	Factory setting
	0.00 [Arms]	10000.00 [Arms]	- [Arms]
Description:	Displays the identified rated motor current.		
p0344[0...n]	Motor weight (for the thermal motor model) / Mot weight th mod		
	Access level: 3	Calculated: p0340 = 1	Data type: FloatingPoint32
	Can be changed: T	Scaling: -	Dyn. index: DDS, p0180
	Unit group: 27_1	Unit selection: p0100	Func. diagram: -
	Min	Max	Factory setting
	0.0 [kg]	50000.0 [kg]	0.0 [kg]
Description:	Sets the motor weight.		
Dependency:	IEC drives (p0100 = 0): unit kg NEMA drives (p0100 = 1): unit lb		
Notice:	When selecting a catalog motor (p0301), this parameter is automatically pre-assigned and is write protected. Information in p0300 should be carefully observed when removing write protection.		
Note:	The parameter influences the thermal 3 mass model of the induction motor.		
r0345[0...n]	Nominal motor starting time / Mot t_start_rated		
	Access level: 3	Calculated: -	Data type: FloatingPoint32
	Can be changed: -	Scaling: -	Dyn. index: DDS, p0180
	Unit group: -	Unit selection: -	Func. diagram: -
	Min	Max	Factory setting
	- [s]	- [s]	- [s]
Description:	Displays the rated motor starting time. This time corresponds to the time from standstill up to reaching the motor rated speed and the acceleration with motor rated torque (r0333).		
Dependency:	Refer to: r0313, r0333, p0341, p0342		

p0346[0...n]	Motor excitation build-up time / Mot t_{excitation}		
	Access level: 3	Calculated: p0340 = 1,3	Data type: FloatingPoint32
	Can be changed: U, T	Scaling: -	Dyn. index: DDS, p0180
	Unit group: -	Unit selection: -	Func. diagram: -
	Min	Max	Factory setting
	0.000 [s]	20.000 [s]	0.000 [s]
Description:	Sets the excitation build-up time of the motor. This involves the delay time between enabling the pulses and enabling the ramp-function generator. The induction motor is magnetized during this time.		
Caution:	If there is insufficient magnetization under load or if the acceleration rate is too high, then an induction motor can stall (refer to the note).		
			
Note:	The parameter is calculated using p0340 = 1, 3. For induction motors, the result depends on the rotor time constant (r0384). If this time is excessively reduced, this can result in an inadequate magnetizing of the induction motor. This is the case if the current limit is reached while building up magnetizing. For induction motors, the parameter cannot be set to 0 s (internal limit: 0.1 * r0384).		

p0347[0...n]	Motor de-excitation time / Mot t_{de-excitat}		
	Access level: 3	Calculated: p0340 = 1,3	Data type: FloatingPoint32
	Can be changed: U, T	Scaling: -	Dyn. index: DDS, p0180
	Unit group: -	Unit selection: -	Func. diagram: -
	Min	Max	Factory setting
	0.000 [s]	20.000 [s]	0.000 [s]
Description:	Sets the de-magnetizing time (for induction motors) after the inverter pulses have been canceled. The inverter pulses cannot be switched in (enabled) within this delay time.		
Note:	The parameter is calculated using p0340 = 1, 3. For induction motors, the result depends on the rotor time constant (r0384). if this time is shortened too much, then this can result in an inadequate de-magnetizing of the induction motor and in an overcurrent condition when the pulses are subsequently enabled (only when the flying restart function is activated and the motor is rotating).		

p0350[0...n]	Motor stator resistance cold / Mot R_{stator cold}		
	Access level: 3	Calculated: p0340 = 1,2	Data type: FloatingPoint32
	Can be changed: U, T	Scaling: -	Dyn. index: DDS, p0180
	Unit group: -	Unit selection: -	Func. diagram: -
	Min	Max	Factory setting
	0.00000 [ohm]	2000.00000 [ohm]	0.00000 [ohm]
Description:	Sets the stator resistance of the motor at ambient temperature p0625 (phase value).		
Dependency:	Refer to: p0625, r1912		
Notice:	When selecting a catalog motor (p0301), this parameter is automatically pre-assigned and is write protected. Information in p0300 should be carefully observed when removing write protection.		
Note:	The motor identification routine determines the stator resistance from the total stator resistance minus the cable resistance (p0352).		

p0352[0...n]	Cable resistance / R_{cable}		
	Access level: 3	Calculated: -	Data type: FloatingPoint32
	Can be changed: U, T	Scaling: -	Dyn. index: DDS, p0180
	Unit group: -	Unit selection: -	Func. diagram: -
	Min	Max	Factory setting
	0.00000 [ohm]	120.00000 [ohm]	0.00000 [ohm]
Description:	Resistance of the power cable between the power unit and motor.		
Caution:	The cable resistance should be entered prior to motor data identification. If it is used subsequently, the difference by which p0352 was changed must be subtracted from the stator resistance p0350 or motor data identification must be repeated.		
			

Note: The parameter influences the temperature adaptation of the stator resistance.
The motor identification sets the cable resistance to 20% of the measured total resistance if p0352 is zero at the time that the measurement is made. If p0352 is not zero, then the value is subtracted from the measured total stator resistance to calculate stator resistance p0350. In this case, p0350 is a minimum of 10% of the measured value.
The cable resistance is reset when quick commissioning is exited with p3900 > 0.

p0354[0...n]	Motor rotor resistance cold / Mot R_r cold		
	Access level: 3	Calculated: p0340 = 1,2	Data type: FloatingPoint32
	Can be changed: U, T	Scaling: -	Dyn. index: DDS, p0180
	Unit group: -	Unit selection: -	Func. diagram: 6727
	Min	Max	Factory setting
	0.00000 [ohm]	300.00000 [ohm]	0.00000 [ohm]
Description:	Sets the rotor/secondary section resistance of the motor at the ambient temperature p0625. This parameter value is automatically calculated using the motor model (p0340 = 1, 2) or using the motor data identification routine (p1910).		
Dependency:	Refer to: p0625		
Notice:	When selecting a catalog motor (p0301), this parameter is automatically pre-assigned and is write protected. Information in p0300 should be carefully observed when removing write protection.		
Note:	The parameter is not used for synchronous motors (p0300 = 2).		

p0356[0...n]	Motor stator leakage inductance / Mot L_stator leak.		
	Access level: 3	Calculated: p0340 = 1,2	Data type: FloatingPoint32
	Can be changed: U, T	Scaling: -	Dyn. index: DDS, p0180
	Unit group: -	Unit selection: -	Func. diagram: -
	Min	Max	Factory setting
	0.00000 [mH]	1000.00000 [mH]	0.00000 [mH]
Description:	Induction machine: sets the stator leakage inductance of the motor. Synchronous motor: Sets the stator quadrature axis inductance of the motor. This parameter value is automatically calculated using the motor model (p0340 = 1, 2) or using the motor identification routine (p1910).		
Notice:	When selecting a catalog motor (p0301), this parameter is automatically pre-assigned and is write protected. Information in p0300 should be carefully observed when removing write protection.		
Note:	If the stator leakage inductance (p0356) for induction motors is changed outside the commissioning phase (p0010 > 0), the magnetizing inductance (p0360) is automatically adapted to the new EMF (r0337). You are then advised to repeat the measurement for the saturation characteristic (p1960).		

p0357[0...n]	Motor stator inductance d axis / Mot L_stator d		
	Access level: 3	Calculated: p0340 = 1,2	Data type: FloatingPoint32
	Can be changed: U, T	Scaling: -	Dyn. index: DDS, p0180
	Unit group: -	Unit selection: -	Func. diagram: -
	Min	Max	Factory setting
	0.00000 [mH]	1000.00000 [mH]	0.00000 [mH]
Description:	Sets the stator direct-axis inductance of the synchronous motor. This parameter value is automatically calculated using the motor model (p0340 = 1, 2) or using the motor identification routine (p1910).		

p0358[0...n]	Motor rotor leakage inductance / Mot L_rot leak		
	Access level: 3	Calculated: p0340 = 1,2	Data type: FloatingPoint32
	Can be changed: U, T	Scaling: -	Dyn. index: DDS, p0180
	Unit group: -	Unit selection: -	Func. diagram: 6727
	Min	Max	Factory setting
	0.00000 [mH]	1000.00000 [mH]	0.00000 [mH]
Description:	Sets the rotor/secondary section leakage inductance of the motor. The value is automatically calculated using the motor model (p0340 = 1, 2) or using the motor identification routine (p1910).		

2 Parameters

2.2 List of parameters

- Notice:** When selecting a catalog motor (p0301), this parameter is automatically pre-assigned and is write protected. Information in p0300 should be carefully observed when removing write protection.
- Note:** If the rotor leakage inductance (p0358) for induction motors is changed outside the commissioning phase (p0010 > 0), then the magnetizing inductance (p0360) is automatically adapted to the new EMF (r0337). You are then advised to repeat the measurement for the saturation characteristic (p1960).

p0360[0...n]	Motor magnetizing inductance / Mot Lh		
	Access level: 3	Calculated: p0340 = 1,2	Data type: FloatingPoint32
	Can be changed: U, T	Scaling: -	Dyn. index: DDS, p0180
	Unit group: -	Unit selection: -	Func. diagram: 6727
	Min	Max	Factory setting
	0.00000 [mH]	10000.00000 [mH]	0.00000 [mH]
Description:	Sets the magnetizing inductance of the motor. This parameter value is automatically calculated using the motor model (p0340 = 1, 2) or using the motor identification routine (p1910).		
Notice:	When selecting a catalog motor (p0301), this parameter is automatically pre-assigned and is write protected. Information in p0300 should be carefully observed when removing write protection.		

p0362[0...n]	Motor saturation characteristic flux 1 / Mot saturat.flux 1		
	Access level: 4	Calculated: -	Data type: FloatingPoint32
	Can be changed: U, T	Scaling: -	Dyn. index: DDS, p0180
	Unit group: -	Unit selection: -	Func. diagram: 6723
	Min	Max	Factory setting
	10.0 [%]	800.0 [%]	60.0 [%]
Description:	The saturation characteristics (flux as a function of the magnetizing current) is defined using 4 points. This parameter specifies the y coordinate (flux) for the 1st value pair of the characteristic. Sets the first flux value of the saturation characteristic as a [%] referred to the rated motor flux (100 %).		
Dependency:	The following applies for the flux values: p0362 < p0363 < p0364 < p0365 Refer to: p0366		
Note:	For induction motors, p0362 = 100 % corresponds to the rated motor flux. When quick commissioning is exited with p3900 > 0, then the parameter is reset if a catalog motor has not been selected (p0300).		

p0363[0...n]	Motor saturation characteristic flux 2 / Mot saturat.flux 2		
	Access level: 4	Calculated: -	Data type: FloatingPoint32
	Can be changed: U, T	Scaling: -	Dyn. index: DDS, p0180
	Unit group: -	Unit selection: -	Func. diagram: 6723
	Min	Max	Factory setting
	10.0 [%]	800.0 [%]	85.0 [%]
Description:	The saturation characteristics (flux as a function of the magnetizing current) is defined using 4 points. This parameter specifies the y coordinate (flux) for the 2nd value pair of the characteristic. Sets the second flux value of the saturation characteristic as a [%] referred to the rated motor flux (100 %).		
Dependency:	The following applies for the flux values: p0362 < p0363 < p0364 < p0365 Refer to: p0367		
Note:	For induction motors, p0363 = 100 % corresponds to the rated motor flux. When quick commissioning is exited with p3900 > 0, then the parameter is reset if a catalog motor has not been selected (p0300).		

p0364[0...n]	Motor saturation characteristic flux 3 / Mot saturat.flux 3		
	Access level: 4	Calculated: -	Data type: FloatingPoint32
	Can be changed: U, T	Scaling: -	Dyn. index: DDS, p0180
	Unit group: -	Unit selection: -	Func. diagram: 6723
	Min	Max	Factory setting
	10.0 [%]	800.0 [%]	115.0 [%]
Description:	The saturation characteristics (flux as a function of the magnetizing current) is defined using 4 points. This parameter specifies the y coordinate (flux) for the 3rd value pair of the characteristic. Sets the third flux value of the saturation characteristic as a [%] referred to the rated motor flux (100 %).		
Dependency:	The following applies for the flux values: p0362 < p0363 < p0364 < p0365 Refer to: p0368		
Note:	For induction motors, p0364 = 100 % corresponds to the rated motor flux. When quick commissioning is exited with p3900 > 0, then the parameter is reset if a catalog motor has not been selected (p0300).		
p0365[0...n]	Motor saturation characteristic flux 4 / Mot saturat.flux 4		
	Access level: 4	Calculated: -	Data type: FloatingPoint32
	Can be changed: U, T	Scaling: -	Dyn. index: DDS, p0180
	Unit group: -	Unit selection: -	Func. diagram: 6723
	Min	Max	Factory setting
	10.0 [%]	800.0 [%]	125.0 [%]
Description:	The saturation characteristics (flux as a function of the magnetizing current) is defined using 4 points. This parameter specifies the y coordinate (flux) for the 4th value pair of the characteristic. Sets the fourth flux value of the saturation characteristic as a [%] referred to the rated motor flux (100 %).		
Dependency:	The following applies for the flux values: p0362 < p0363 < p0364 < p0365 Refer to: p0369		
Note:	For induction motors, p0365 = 100 % corresponds to the rated motor flux. When quick commissioning is exited with p3900 > 0, then the parameter is reset if a catalog motor has not been selected (p0300).		
p0366[0...n]	Motor saturation characteristic I_mag 1 / Mot sat. I_mag 1		
	Access level: 4	Calculated: -	Data type: FloatingPoint32
	Can be changed: U, T	Scaling: -	Dyn. index: DDS, p0180
	Unit group: -	Unit selection: -	Func. diagram: 6723
	Min	Max	Factory setting
	5.0 [%]	800.0 [%]	50.0 [%]
Description:	The saturation characteristics (flux as a function of the magnetizing current) is defined using 4 points. This parameter specifies the x coordinate (magnetizing current) for the 1st value pair of the characteristic. Sets the first magnetization current of the saturation characteristic in [%] with reference to the rated magnetization current (r0331).		
Dependency:	The following applies for the magnetizing currents: p0366 < p0367 < p0368 < p0369 Refer to: p0362		
Note:	When quick commissioning is exited with p3900 > 0, then the parameter is reset if a catalog motor has not been selected (p0300).		

p0367[0...n]	Motor saturation characteristic I_mag 2 / Mot sat. I_mag 2		
	Access level: 4	Calculated: -	Data type: FloatingPoint32
	Can be changed: U, T	Scaling: -	Dyn. index: DDS, p0180
	Unit group: -	Unit selection: -	Func. diagram: 6723
	Min	Max	Factory setting
	5.0 [%]	800.0 [%]	75.0 [%]
Description:	The saturation characteristics (flux as a function of the magnetizing current) is defined using 4 points. This parameter specifies the x coordinate (magnetizing current) for the 2nd value pair of the characteristic. Sets the second magnetization current of the saturation characteristic in [%] with reference to the rated magnetization current (r0331).		
Dependency:	The following applies for the magnetizing currents: p0366 < p0367 < p0368 < p0369 Refer to: p0363		
Note:	When quick commissioning is exited with p3900 > 0, then the parameter is reset if a catalog motor has not been selected (p0300).		
p0368[0...n]	Motor saturation characteristic I_mag 3 / Mot sat. I_mag 3		
	Access level: 4	Calculated: -	Data type: FloatingPoint32
	Can be changed: U, T	Scaling: -	Dyn. index: DDS, p0180
	Unit group: -	Unit selection: -	Func. diagram: 6723
	Min	Max	Factory setting
	5.0 [%]	800.0 [%]	150.0 [%]
Description:	The saturation characteristics (flux as a function of the magnetizing current) is defined using 4 points. This parameter specifies the x coordinate (magnetizing current) for the 3rd value pair of the characteristic. Sets the third magnetization current of the saturation characteristic in [%] with reference to the rated magnetization current (r0331).		
Dependency:	The following applies for the magnetizing currents: p0366 < p0367 < p0368 < p0369 Refer to: p0364		
Note:	When quick commissioning is exited with p3900 > 0, then the parameter is reset if a catalog motor has not been selected (p0300).		
p0369[0...n]	Motor saturation characteristic I_mag 4 / Mot sat. I_mag 4		
	Access level: 4	Calculated: -	Data type: FloatingPoint32
	Can be changed: U, T	Scaling: -	Dyn. index: DDS, p0180
	Unit group: -	Unit selection: -	Func. diagram: 6723
	Min	Max	Factory setting
	5.0 [%]	800.0 [%]	210.0 [%]
Description:	The saturation characteristics (flux as a function of the magnetizing current) is defined using 4 points. This parameter specifies the x coordinate (magnetizing current) for the 4th value pair of the characteristic. Sets the fourth magnetization current of the saturation characteristic in [%] with reference to the rated magnetization current (r0331).		
Dependency:	The following applies for the magnetizing currents: p0366 < p0367 < p0368 < p0369 Refer to: p0365		
Note:	When quick commissioning is exited with p3900 > 0, then the parameter is reset if a catalog motor has not been selected (p0300).		

r0370[0...n]	Motor stator resistance cold / Mot R_stator cold		
	Access level: 4	Calculated: -	Data type: FloatingPoint32
	Can be changed: -	Scaling: -	Dyn. index: DDS, p0180
	Unit group: -	Unit selection: -	Func. diagram: -
	Min	Max	Factory setting
	- [ohm]	- [ohm]	- [ohm]
Description:	Displays the motor stator resistance at an ambient temperature (p0625). The value does not include the cable resistance.		
Dependency:	Refer to: p0625		
r0372[0...n]	Cable resistance / Mot R_cable		
	Access level: 4	Calculated: -	Data type: FloatingPoint32
	Can be changed: -	Scaling: -	Dyn. index: DDS, p0180
	Unit group: -	Unit selection: -	Func. diagram: -
	Min	Max	Factory setting
	- [ohm]	- [ohm]	- [ohm]
Description:	Displays the total cable resistance between power unit and motor, as well as the internal converter resistance.		
Dependency:	Refer to: r0238, p0352		
r0373[0...n]	Motor rated stator resistance / Mot R_stator rated		
	Access level: 4	Calculated: -	Data type: FloatingPoint32
	Can be changed: -	Scaling: -	Dyn. index: DDS, p0180
	Unit group: -	Unit selection: -	Func. diagram: -
	Min	Max	Factory setting
	- [ohm]	- [ohm]	- [ohm]
Description:	Displays the rated motor stator resistance at rated temperature (total of p0625 and p0627).		
Dependency:	Refer to: p0627		
Note:	The parameter is not used for synchronous motors (p0300 = 2xx).		
r0374[0...n]	Motor rotor resistance cold / Mot R_r cold		
	Access level: 4	Calculated: -	Data type: FloatingPoint32
	Can be changed: -	Scaling: -	Dyn. index: DDS, p0180
	Unit group: -	Unit selection: -	Func. diagram: -
	Min	Max	Factory setting
	- [ohm]	- [ohm]	- [ohm]
Description:	Displays the motor rotor resistance at an ambient temperature p0625.		
Dependency:	Refer to: p0625		
Note:	The parameter is not used for synchronous motors (p0300 = 2xx).		
r0376[0...n]	Rated motor rotor resistance / Mot rated R_rotor		
	Access level: 4	Calculated: -	Data type: FloatingPoint32
	Can be changed: -	Scaling: -	Dyn. index: DDS, p0180
	Unit group: -	Unit selection: -	Func. diagram: -
	Min	Max	Factory setting
	- [ohm]	- [ohm]	- [ohm]
Description:	Displays the nominal rotor resistance of the motor at the rated temperature. The rated temperature is the sum of p0625 and p0628.		
Dependency:	Refer to: p0628		
Note:	The parameter is not used for synchronous motors (p0300 = 2xx).		

r0377[0...n]	Motor leakage inductance total / Mot L_leak total		
	Access level: 4	Calculated: -	Data type: FloatingPoint32
	Can be changed: -	Scaling: -	Dyn. index: DDS, p0180
	Unit group: -	Unit selection: -	Func. diagram: -
	Min	Max	Factory setting
	- [mH]	- [mH]	- [mH]
Description:	Displays the stator leakage inductance of the motor including the motor reactor (p0233).		
r0378[0...n]	Motor stator inductance d axis / Mot L_stator d		
	Access level: 4	Calculated: -	Data type: FloatingPoint32
	Can be changed: -	Scaling: -	Dyn. index: DDS, p0180
	Unit group: -	Unit selection: -	Func. diagram: -
	Min	Max	Factory setting
	- [mH]	- [mH]	- [mH]
Description:	Displays the stator longitudinal inductance of the synchronous motor including the motor reactor (p0233).		
r0382[0...n]	Motor magnetizing inductance transformed / Mot L_magn transf		
	Access level: 4	Calculated: -	Data type: FloatingPoint32
	Can be changed: -	Scaling: -	Dyn. index: DDS, p0180
	Unit group: -	Unit selection: -	Func. diagram: -
	Min	Max	Factory setting
	- [mH]	- [mH]	- [mH]
Description:	Displays the magnetizing inductance of the motor.		
Note:	The parameter is not used for synchronous motors (p0300 = 2xx).		
r0384[0...n]	Motor rotor time constant / damping time constant d axis / Mot T_rotor/T_Dd		
	Access level: 3	Calculated: -	Data type: FloatingPoint32
	Can be changed: -	Scaling: -	Dyn. index: DDS, p0180
	Unit group: -	Unit selection: -	Func. diagram: 6722
	Min	Max	Factory setting
	- [ms]	- [ms]	- [ms]
Description:	Displays the rotor time constant.		
Note:	The parameter is not used for synchronous motors. The value is calculated from the total of the inductances on the rotor side (p0358, p0360) divided by the rotor resistance (p0354). The temperature adaptation of the rotor resistance for induction motors is not taken into account.		
r0386[0...n]	Motor stator leakage time constant / Mot T_stator leak		
	Access level: 4	Calculated: -	Data type: FloatingPoint32
	Can be changed: -	Scaling: -	Dyn. index: DDS, p0180
	Unit group: -	Unit selection: -	Func. diagram: -
	Min	Max	Factory setting
	- [ms]	- [ms]	- [ms]
Description:	Displays the stator leakage time constant.		
Note:	The value is calculated from the total of all leakage inductances (p0233, p0356, p0358) divided by the total of all motor resistances (p0350, p0352, p0354). The temperature adaptation of the resistances is not taken into account.		

r0394[0...n]	Rated motor power / Mot P_{rated}		
	Access level: 3	Calculated: -	Data type: FloatingPoint32
	Can be changed: -	Scaling: -	Dyn. index: DDS, p0180
	Unit group: 14_6	Unit selection: p0100	Func. diagram: -
	Min	Max	Factory setting
	- [kW]	- [kW]	- [kW]
Description:	Displays the rated motor power.		
Note:	The parameter displays p0307. For p0307 = 0, r0394 is calculated from p0304 and p0305 (only for induction motors). Depending on the actual motor type, deviations can occur from the actual rated motor power.		
r0395[0...n]	Actual stator resistance / R_{stator act}		
	Access level: 3	Calculated: -	Data type: FloatingPoint32
	Can be changed: -	Scaling: -	Dyn. index: DDS, p0180
	Unit group: -	Unit selection: -	Func. diagram: -
	Min	Max	Factory setting
	- [ohm]	- [ohm]	- [ohm]
Description:	Displays the actual stator resistance (phase value). The parameter value also contains the temperature-independent cable resistance.		
Dependency:	In the case of induction motors the parameter is also affected by the motor temperature model. Refer to: p0350, p0352, p0620		
Note:	In each case, only the stator resistance of the active Motor Data Set is included with the stator temperature of the thermal motor model.		
r0396[0...n]	Actual rotor resistance / R_{rotor act}		
	Access level: 3	Calculated: -	Data type: FloatingPoint32
	Can be changed: -	Scaling: -	Dyn. index: DDS, p0180
	Unit group: -	Unit selection: -	Func. diagram: -
	Min	Max	Factory setting
	- [ohm]	- [ohm]	- [ohm]
Description:	Displays the actual rotor resistance (phase value). The parameter is affected by the motor temperature model.		
Dependency:	Refer to: p0354, p0620		
Note:	In each case, only the rotor resistance of the active Motor Data Set is included with the rotor temperature of the thermal motor model. This parameter is not used for synchronous motors (p0300 = 2xx).		
p0400[0...n]	Encoder type selection / Enc_{typ sel}		
	Access level: 1	Calculated: -	Data type: Integer16
	Can be changed: C(1, 4)	Scaling: -	Dyn. index: EDS, p0140
	Unit group: -	Unit selection: -	Func. diagram: 4700, 4704
	Min	Max	Factory setting
	0	9999	0
Description:	Selects the encoder from the list of encoder types supported.		
Value:	0: No encoder 9999: User-defined		
p0405[0...n]	Square-wave encoder track A/B / Sq-wave enc A/B		
	Access level: 3	Calculated: -	Data type: Unsigned32
	Can be changed: C(4)	Scaling: -	Dyn. index: EDS, p0140
	Unit group: -	Unit selection: -	Func. diagram: 4704
	Min	Max	Factory setting
	-	-	0000 0000 bin
Description:	Settings for the track A/B in a square-wave encoder.		

2 Parameters

2.2 List of parameters

Bit field:	Bit	Signal name	1 signal	0 signal	FP
	05	Pulse/direction	Active	Inactive	-
Notice:	This parameter is automatically pre-set for encoders from the encoder list (p0400). When selecting a catalog encoder, this parameter cannot be changed (write protection). Information in p0400 should be carefully observed when removing write protection.				
Note:	For bit 05: When the function is activated, a frequency setpoint and a direction for traveling can be entered via an encoder interface.				

p0408[0...n]	Rotary encoder pulse number / Rot enc pulse No.				
	Access level: 3	Calculated: -	Data type: Unsigned32		
	Can be changed: C(4)	Scaling: -	Dyn. index: EDS, p0140		
	Unit group: -	Unit selection: -	Func. diagram: 4010, 4704		
	Min	Max	Factory setting		
	0	16777215	2048		
Description:	Sets the number of pulses for a rotary encoder.				
Notice:	This parameter is automatically pre-set for encoders from the encoder list (p0400). When selecting a catalog encoder, this parameter cannot be changed (write protection). Information in p0400 should be carefully observed when removing write protection.				
Note:	The number of pole pairs for a resolver is entered here. The smallest permissible value is 1 pulse.				

p0410[0...n]	Encoder inversion actual value / Enc inv act value				
	Access level: 3	Calculated: -	Data type: Unsigned16		
	Can be changed: C(4)	Scaling: -	Dyn. index: EDS, p0140		
	Unit group: -	Unit selection: -	Func. diagram: 4704, 4710, 4711, 4715		
	Min	Max	Factory setting		
	-	-	0000 bin		
Description:	Setting to invert actual values.				
Bit field:	Bit	Signal name	1 signal	0 signal	FP
	01	Invert position actual value	Yes	No	4704
Note:	The inversion influences the following parameters: Bit 01: r0482, r0483				

p0480[0...2]	CI: Encoder control word Gn_STW signal source / Enc Gn_STW s_s				
	Access level: 3	Calculated: -	Data type: U32 / Integer16		
	Can be changed: T	Scaling: -	Dyn. index: -		
	Unit group: -	Unit selection: -	Func. diagram: 4720, 4750		
	Min	Max	Factory setting		
	-	-	[0] 0		
			[1] 0		
			[2] 0		
Description:	Sets the signal source for the encoder control word Gn_STW according to PROFIdrive.				
Index:	[0] = Encoder 1 [1] = Reserved [2] = Reserved				

r0481[0...2]	CO: Encoder status word Gn_ZSW / Enc Gn_ZSW				
	Access level: 3	Calculated: -	Data type: Unsigned16		
	Can be changed: -	Scaling: -	Dyn. index: -		
	Unit group: -	Unit selection: -	Func. diagram: 4704, 4730		
	Min	Max	Factory setting		
	-	-	-		
Description:	Displays the encoder status word Gn_ZSW according to PROFIdrive.				
Index:	[0] = Encoder 1 [1] = Reserved [2] = Reserved				
Bit field:	Bit	Signal name	1 signal	0 signal	FP
	00	Function 1 active	Yes	No	-
	01	Function 2 active	Yes	No	-
	02	Function 3 active	Yes	No	-
	03	Function 4 active	Yes	No	-
	04	Value 1	Displayed in r0483	Not present	-
	05	Value 2	Displayed in r0483	Not present	-
	06	Value 3	Displayed in r0483	Not present	-
	07	Value 4	Displayed in r0483	Not present	-
	08	Measuring probe 1 deflected	Yes	No	-
	09	Measuring probe 2 deflected	Yes	No	-
	11	Encoder fault acknowledge active	Yes	No	9676
	13	Absolute value cyclically	Displayed in r0483	No	-
	14	Parking encoder active	Yes	No	-
	15	Encoder fault	Displayed in r0483	None	-
Note:	For bit 14: Displays the acknowledgment for "activate parking encoder" (Gn_STW.14 = 1) or encoder position actual value (Gn_XIST1) invalid. For bit 14, 15: r0481.14 = 1 and r0481.15 = 0 can have one of the following causes: - the encoder is parked. - the encoder is deactivated. - the encoder is being commissioned. - no parameterized encoder available. - encoder data set is being changed over. r0481.14 = 1 and r0481.15 = 1 has the following significance: An encoder error has occurred and the encoder position actual value (Gn_XIST1) is invalid.				

r0482[0...2]	CO: Encoder actual position value Gn_XIST1 / Enc Gn_XIST1			
	Access level: 3	Calculated: -	Data type: Unsigned32	
	Can be changed: -	Scaling: -	Dyn. index: -	
	Unit group: -	Unit selection: -	Func. diagram: 4700, 4702, 4704, 4735, 4740, 4750	
	Min	Max	Factory setting	
	-	-	-	
Description:	Display and connector output for the encoder actual position value Gn_XIST1 according to PROFIdrive.			
Index:	[0] = Encoder 1 [1] = Reserved [2] = Reserved			

p0500	Technology application / Tec application		
	Access level: 2	Calculated: -	Data type: Integer16
	Can be changed: C(1), T	Scaling: -	Dyn. index: -
	Unit group: -	Unit selection: -	Func. diagram: -
	Min	Max	Factory setting
	0	5	0
Description:	Sets the technology application. The parameter influences the calculation of open-loop and closed-loop control parameters that is e.g. initiated using p0340 = 5.		
Value:	0: Standard drive 3: Pumps and fans, efficiency optimization 5: Starting with a high break loose torque		
Notice:	If the technological application is set to p0500 = 0, 3 during commissioning (p0010 = 1, 5, 30), the operating mode (p1300) is pre-set accordingly.		
Note:	The calculation of parameters dependent on the technology application can be called up as follows: - when exiting quick commissioning using p3900 > 0 - when writing p0340 = 1, 3, 5 For p0500 = 0 and when the calculation is initiated, the following parameters are set: - p1574 = 10 V - p1580 = 0 % - p1750.2 = 0 - p1802 = 0 - p1803 = 106 % For p0500 = 3 and when the calculation is initiated, the following parameters are set: - p1574 = 2 V - p1580 = 80 % (efficiency optimization) - p1750.2 = 1 - p1802 = 0 - p1803 = 110 % For p0500 = 5 and when the calculation is initiated, the following parameters are set: - p1574, p1580, p1750.2, p1802, p1803 same as for p0500 = 0 - p1610 = 80 %, p1611 = 80 % (average up to higher starting torque) - p1310 = 80 %, p1311 = 30 % For p1750: The setting of p1750 is only relevant for induction motors. p1750.2 = 1: Encoderless control of the induction motor is effective down to zero frequency. This operating mode is possible for passive loads. These include applications where the load does not generate regenerative torque when breaking away and the motor comes to a standstill (zero speed) itself when the pulses are inhibited.		

p0505	Selecting the system of units / Unit sys select		
	Access level: 1	Calculated: -	Data type: Integer16
	Can be changed: C(5)	Scaling: -	Dyn. index: -
	Unit group: -	Unit selection: -	Func. diagram: -
	Min	Max	Factory setting
	1	4	1
Description:	Sets the actual system of units.		
Value:	1: SI system of units 2: System of units referred/SI 3: US system of units 4: System of units referred/US		
Dependency:	The parameter can only be changed in an offline project using the commissioning software.		
Caution:	If a per unit representation is selected and if the reference parameters (e.g. p2000) are subsequently changed, then the physical significance of several control parameters is also adapted at the same time. As a consequence, the control behavior can change (see p1744, p1752, p1755).		
			

Note: Reference parameter for the unit system % are, for example, p2000 ... p2004. Depending on what has been selected, these are displayed using either SI or US units.

p0541[0...n]	Load gearbox code number / Load grbx CodeNo		
Access level: 3	Calculated: -	Data type: Unsigned32	
Can be changed: C(1, 3)	Scaling: -	Dyn. index: DDS, p0180	
Unit group: -	Unit selection: -	Func. diagram: -	
Min	Max	Factory setting	
0	4294967295	1	
Description:	Display and setting the code number for the load gearbox. 0 = No data 1 = Manual entry > 1 = valid code number If value = 0: - parameters listed under Dependent are set to a value of zero and are write protected. For value = 1: - write protection for the parameters listed under Dependent is withdrawn. If value > 1: - parameters listed under Dependent are automatically preassigned and are write protected.		
Note:	A code number that does not exist cannot be set.		

p0542[0...n]	Load gearbox maximum speed / Load grbx n_max		
Access level: 3	Calculated: -	Data type: FloatingPoint32	
Can be changed: C(1, 3)	Scaling: -	Dyn. index: DDS, p0180	
Unit group: -	Unit selection: -	Func. diagram: -	
Min	Max	Factory setting	
0.0 [rpm]	340.28235E36 [rpm]	0.0 [rpm]	
Description:	Sets the maximum permissible input speed at the load gearbox. When calculating the maximum speed (p1082) in quick commissioning (p0010 = 1), the following applies: - for p0542 = 0, this parameter has no effect. The maximum speed from p0322 is used. - for p0542 > 0, the maximum speed (p0322) is limited by p0542.		
Notice:	After entering a corresponding code number (p0541), this parameter is automatically preassigned and write protected. The information in p0541 should be observed when removing write protection.		

p0543[0...n]	Load gearbox maximum torque / Load grbx M_max		
Access level: 3	Calculated: -	Data type: FloatingPoint32	
Can be changed: C(1, 3)	Scaling: -	Dyn. index: DDS, p0180	
Unit group: 7_1	Unit selection: p0505	Func. diagram: -	
Min	Max	Factory setting	
0.00 [Nm]	340.28235E36 [Nm]	0.00 [Nm]	
Description:	Sets the maximum permissible input torque at the load gearbox. When calculating the upper/motoring torque limit (p1520) and the lower/generating torque limit (p1521) in quick commissioning (p0010 = 1), then the following applies: - for p0543 = 0, the values in p1520/p1521 remain unchanged. - for p0543 > 0, the torque limits (r1538, r1539) are limited by p0543.		
Notice:	After entering a corresponding code number (p0541), this parameter is automatically preassigned and write protected. The information in p0541 should be observed when removing write protection.		

p0544[0...n]	Load gearbox overall ratio (absolute value) numerator / Load grbx ratio N		
	Access level: 3	Calculated: -	Data type: Integer32
	Can be changed: C(1, 3)	Scaling: -	Dyn. index: DDS, p0180
	Unit group: -	Unit selection: -	Func. diagram: -
	Min	Max	Factory setting
	0	2147483647	0
Description:	Sets the numerator for the overall ratio (absolute value) of the load gearbox.		
Notice:	After entering a corresponding code number (p0541), this parameter is automatically preassigned and write protected. The information in p0541 should be observed when removing write protection.		
p0545[0...n]	Load gearbox overall ratio (absolute value) denominator / Load grbx ratio D		
	Access level: 3	Calculated: -	Data type: Integer32
	Can be changed: C(1, 3)	Scaling: -	Dyn. index: DDS, p0180
	Unit group: -	Unit selection: -	Func. diagram: -
	Min	Max	Factory setting
	0	2147483647	0
Description:	Sets the denominator for the overall ratio (absolute value) of the load gearbox.		
Notice:	After entering a corresponding code number (p0541), this parameter is automatically preassigned and write protected. The information in p0541 should be observed when removing write protection.		
p0546[0...n]	Load gearbox output direction of rotation inversion / Load grbx outp inv		
	Access level: 3	Calculated: -	Data type: Integer32
	Can be changed: C(1, 3)	Scaling: -	Dyn. index: DDS, p0180
	Unit group: -	Unit selection: -	Func. diagram: -
	Min	Max	Factory setting
	0	2147483647	0
Description:	Setting to invert the direction of rotation of the load gearbox. Value = 0: no inversion Value = 1: inversion		
Notice:	After entering a corresponding code number (p0541), this parameter is automatically preassigned and write protected. The information in p0541 should be observed when removing write protection.		
p0550[0...n]	Brake type / Brake type		
	Access level: 4	Calculated: -	Data type: Unsigned16
	Can be changed: C(1, 3)	Scaling: -	Dyn. index: DDS, p0180
	Unit group: -	Unit selection: -	Func. diagram: -
	Min	Max	Factory setting
	0	2	0
Description:	Sets the brake version.		
Notice:	After entering a corresponding code number (p0551), this parameter is automatically preassigned and write protected. The information in p0551 should be observed when removing write protection.		

p0551[0...n]	Brake code number / Brake code no.		
	Access level: 3	Calculated: -	Data type: Unsigned16
	Can be changed: C(1, 3)	Scaling: -	Dyn. index: DDS, p0180
	Unit group: -	Unit selection: -	Func. diagram: -
	Min	Max	Factory setting
	0	65535	1
Description:	Display and setting the code number for the brake. 0 = No data 1 = Manual entry > 1 = valid code number If value = 0: - parameters listed under Dependent are set to a value of zero and are write protected. - parameters p1216, p1217 are set to the default value. For value = 1: - write protection for the parameters listed under Dependent is withdrawn. For value > 1: - parameters listed under Dependent are automatically preassigned and are write protected. - parameters p1216, p1217 are automatically appropriately preassigned.		
Dependency:	Refer to: p0550, p0552, p0553, p0554		
Note:	Only code numbers can be set that are permitted for the selected motor code (p0301).		
p0552[0...n]	Maximum brake speed / Brake n_max		
	Access level: 3	Calculated: -	Data type: FloatingPoint32
	Can be changed: C(1, 3)	Scaling: -	Dyn. index: DDS, p0180
	Unit group: -	Unit selection: -	Func. diagram: -
	Min	Max	Factory setting
	0.0 [rpm]	210000.0 [rpm]	0.0 [rpm]
Description:	Sets the maximum permissible brake speed. When calculating the maximum speed (p1082) in quick commissioning (p0010 = 1), the following applies: - for p0552 = 0, this parameter has no effect. - for p0552 > 0, the maximum speed is limited by p0552.		
Notice:	After entering a corresponding code number (p0551), this parameter is automatically preassigned and write protected. The information in p0551 should be observed when removing write protection.		
p0553[0...n]	Brake holding torque / Brake M_hold		
	Access level: 3	Calculated: -	Data type: FloatingPoint32
	Can be changed: C(1, 3)	Scaling: -	Dyn. index: DDS, p0180
	Unit group: 7_1	Unit selection: p0505	Func. diagram: -
	Min	Max	Factory setting
	0.00 [Nm]	1000000.00 [Nm]	0.00 [Nm]
Description:	Sets the brake holding torque.		
Notice:	After entering a corresponding code number (p0551), this parameter is automatically preassigned and write protected. The information in p0551 should be observed when removing write protection.		
p0554[0...n]	Brake moment of inertia / Brake J		
	Access level: 3	Calculated: -	Data type: Integer32
	Can be changed: C(1, 3)	Scaling: -	Dyn. index: DDS, p0180
	Unit group: -	Unit selection: -	Func. diagram: -
	Min	Max	Factory setting
	0 [kgm ²]	2147483647 [kgm ²]	0 [kgm ²]
Description:	Sets the brake moment of inertia (factor 10 ⁶).		
Notice:	After entering a corresponding code number (p0551), this parameter is automatically preassigned and write protected. The information in p0551 should be observed when removing write protection.		

p0573	Inhibit automatic reference value calculation / Inhibit calc		
	Access level: 3	Calculated: -	Data type: Integer16
	Can be changed: U, T	Scaling: -	Dyn. index: -
	Unit group: -	Unit selection: -	Func. diagram: -
	Min	Max	Factory setting
	0	1	0
Description:	Setting to inhibit the calculation of reference parameters (e.g. p2000) when automatically calculating the motor and closed-loop control parameters (p0340, p3900).		
Value:	0: No 1: Yes		
Notice:	The inhibit for the reference value calculation is canceled when new motor parameters (e.g. p0305) are entered and only one drive data set exists (p0180 = 1). This is the case during initial commissioning. Once the motor and control parameters have been calculated (p0340, p3900), the inhibit for the reference value calculation is automatically re-activated.		
Note:	If value = 0: The automatic calculation (p0340, p3900) overwrites the reference parameters. For value = 1: The automatic calculation (p0340, p3900) does not overwrite the reference parameters.		

p0595	Technological unit selection / Tech unit select		
	Access level: 1	Calculated: -	Data type: Integer16
	Can be changed: C(5)	Scaling: -	Dyn. index: -
	Unit group: -	Unit selection: -	Func. diagram: -
	Min	Max	Factory setting
	1	48	1
Description:	Selects the units for the parameters of the technology controller. For p0595 = 1, 2, the reference quantity set in p0596 is not active.		

Value:	1: %
	2: 1 referred no dimensions
	3: bar
	4: °C
	5: Pa
	6: ltr/s
	7: m ³ /s
	8: ltr/min
	9: m ³ /min
	10: ltr/h
	11: m ³ /h
	12: kg/s
	13: kg/min
	14: kg/h
	15: t/min
	16: t/h
	17: N
	18: kN
	19: Nm
	20: psi
	21: °F
	22: gallon/s
	23: inch ³ /s
	24: gallon/min
	25: inch ³ /min
	26: gallon/h
	27: inch ³ /h
	28: lb/s
	29: lb/min
	30: lb/h
	31: lbf
	32: lbf ft
	33: K
	34: rpm
	35: parts/min
	36: m/s
	37: ft ³ /s
	38: ft ³ /min
	39: BTU/min
	40: BTU/h
	41: mbar
	42: inch wg
	43: ft wg
	44: m wg
	45: % r.h.
	46: g/kg
	47: ppm
	48: kg/cm ²

Dependency: Only the unit of the technology controller parameters are switched over (unit group 9_1).

Refer to: p0596

Note: When switching over from % into another unit, the following sequence applies:

- set p0596

- set p0595 to the required unit

p0596

Technological unit reference quantity / Tech unit ref qty

Access level: 1	Calculated: -	Data type: FloatingPoint32
Can be changed: T	Scaling: -	Dyn. index: -
Unit group: -	Unit selection: -	Func. diagram: -
Min	Max	Factory setting
0.01	340.28235E36	1.00

Description: Sets the reference quantity for the technological units.

When changing over using changeover parameter p0595 to absolute units, all of the parameters involved refer to the reference quantity.

2.2 List of parameters

Dependency: Refer to: p0595
Notice: When changing over from one technological unit into another, or when changing the reference parameter, a changeover is not made.

p0601[0...n] Motor temperature sensor type / Mot_temp_sens type

Access level: 2	Calculated: -	Data type: Integer16
Can be changed: U, T	Scaling: -	Dyn. index: DDS, p0180
Unit group: -	Unit selection: -	Func. diagram: 8016
Min	Max	Factory setting
0	6	0

Description: Sets the sensor type for the motor temperature monitoring.
Value: 0: No sensor
 1: PTC alarm & timer
 2: KTY84
 4: Bimetallic NC contact alarm & timer
 6: PT1000

Dependency: A thermal motor model is calculated corresponding to p0612.
Caution: For p0601 = 2, 6:
 If the motor temperature sensor is not connected but another encoder, then the temperature adaptation of the motor resistances must be switched out (p0620 = 0). Otherwise, in controlled-loop operation, torque errors will occur that will mean that the motor will not be able to be stopped.

Note: For p0601 = 1:
 Tripping resistance = 1650 Ohm. Wire breakage and short-circuit monitoring.

p0604[0...n] Mot_temp_mod 2/sensor alarm threshold / Mod 2/sens A_thr

Access level: 2	Calculated: -	Data type: FloatingPoint32
Can be changed: U, T	Scaling: -	Dyn. index: DDS, p0180
Unit group: 21_1	Unit selection: p0505	Func. diagram: 8016
Min	Max	Factory setting
0.0 [°C]	240.0 [°C]	130.0 [°C]

Description: Sets the alarm threshold for monitoring the motor temperature for motor temperature model 2 or KTY/PT1000. After the alarm threshold is exceeded, alarm A07910 is output and timer (p0606) is started. If the delay time has expired and the alarm threshold has, in the meantime, not been fallen below, then fault F07011 is output.

Dependency: Refer to: p0606, p0612
 Refer to: F07011, A07910

Notice: When selecting a catalog motor (p0301), this parameter is automatically pre-assigned and is write protected. Information in p0300 should be carefully observed when removing write protection.

Note: The hysteresis is 2 K.
 When quick commissioning is exited with p3900 > 0, then the parameter is reset if a catalog motor has not been selected (p0300).

p0605[0...n]	Mot_temp_mod 1/2/sensor threshold and temperature value / Mod1/2/sens T_thr		
	Access level: 2	Calculated: -	Data type: FloatingPoint32
	Can be changed: U, T	Scaling: -	Dyn. index: DDS, p0180
	Unit group: 21_1	Unit selection: p0505	Func. diagram: 8016, 8017
	Min	Max	Factory setting
	0.0 [°C]	240.0 [°C]	145.0 [°C]
Description:	<p>Sets the threshold and temperature value to monitor the motor temperature.</p> <p>Temperature model 1 (I2t, p0612.0 = 1):</p> <p>The following applies for firmware version < 4.7 SP6 or p0612.8 = 0:</p> <ul style="list-style-type: none"> - sets the alarm threshold. If the model temperature (r0034) exceeds the alarm threshold, then alarm A07012 is output. - this value is simultaneously used as rated winding temperature. <p>The following applies from firmware version 4.7 SP6 and p0612.8 = 1:</p> <ul style="list-style-type: none"> - p5390: when commissioning a catalog motor for the first time, p0605 is copied to p5390. - p5390: p5390 is of significance when evaluating the alarm threshold. - p5390: the stator winding temperature (r0632) is used to initiate the signal. - p0627: when a catalog motor is commissioned for the first time, p0605 -40 °C is copied to p0627. - p0627: p0627 is of significance for the rated temperature. <p>Motor temperature model 2 (p0612.1 = 1) or measurement:</p> <ul style="list-style-type: none"> - sets the fault threshold. If the temperature (r0035) exceeds the fault threshold, then fault F07011 is output. 		
Dependency:	<p>Refer to: r0034, p0606, p0611, p0612</p> <p>Refer to: F07011, A07012</p>		
Notice:	<p>When selecting a catalog motor (p0301), this parameter is automatically pre-assigned and is write protected. Information in p0300 should be carefully observed when removing write protection.</p> <p>Motor temperature model 1 (I2t):</p> <p>The following applies for firmware version < 4.7 SP6 or p0612.8 = 0:</p> <p>p0605 also defines the final temperature of the model for r0034 = 100 %. Therefore, p0605 has no influence on the time up to alarm A07012 being issued. The time is only determined by time constant p0611, the actual current and the reference value p0318. For p0318 = 0, the rated motor current is used as reference value.</p>		
Note:	<p>The hysteresis is 2 K.</p> <p>When quick commissioning is exited with p3900 > 0, then the parameter is reset if a catalog motor has not been selected (p0300).</p>		
p0606[0...n]	Mot_temp_mod 2/sensor timer / Mod 2/sens timer		
	Access level: 4	Calculated: -	Data type: FloatingPoint32
	Can be changed: U, T	Scaling: -	Dyn. index: DDS, p0180
	Unit group: -	Unit selection: -	Func. diagram: 8016
	Min	Max	Factory setting
	0.000 [s]	600.000 [s]	0.000 [s]
Description:	<p>Sets the timer for monitoring the motor temperature for motor temperature model 2 or KTY/PT1000.</p> <p>This timer is started when the temperature alarm threshold (p0604) is exceeded.</p> <p>If the timer has expired and the alarm threshold has, in the meantime, not been fallen below, then fault F07011 is output.</p> <p>If the temperature fault threshold (p0605) is prematurely exceeded before the timer has expired, then fault F07011 is immediately output.</p>		
Dependency:	<p>Refer to: p0604, p0605</p> <p>Refer to: F07011, A07910</p>		
Note:	<p>With p0606 = 0 s, the timer is deactivated and only the fault threshold is effective.</p> <p>KTY/PT1000: When setting the minimum value, the timer is disabled and a fault is not output until p0605 is exceeded.</p> <p>PTC, bimetallic NC contact: The timer minimum value has no special significance.</p>		

p0607[0...n]	Temperature sensor fault timer / Sensor fault time		
	Access level: 4	Calculated: -	Data type: FloatingPoint32
	Can be changed: U, T	Scaling: -	Dyn. index: DDS, p0180
	Unit group: -	Unit selection: -	Func. diagram: 8016
	Min	Max	Factory setting
	0.000 [s]	600.000 [s]	0.100 [s]
Description:	Sets the timer between the output of alarm and fault for a temperature sensor fault. If there is a sensor fault, this timer is started. If the sensor fault is still present after the timer has expired, a corresponding fault is output.		
Notice:	The parameterized time is internally rounded-off to an integer multiple of 48 ms.		
Note:	If the motor is an induction motor, the timer is switched off when setting the minimum value and no alarm is output. Temperature monitoring is then based on the thermal model.		
p0610[0...n]	Motor overtemperature response / Mot temp response		
	Access level: 2	Calculated: -	Data type: Integer16
	Can be changed: T	Scaling: -	Dyn. index: DDS, p0180
	Unit group: -	Unit selection: -	Func. diagram: 8016, 8017, 8018
	Min	Max	Factory setting
	0	12	12
Description:	Sets the system response when the motor temperature reaches the alarm threshold.		
Value:	0: No response only alarm no reduction of I_max 1: Messages, reduction of I_max 2: Messages, no reduction of I_max 12: Messages, no reduction of I_max, temperature storage		
Dependency:	Refer to: p0601, p0604, p0605, p0614, p0615 Refer to: F07011, A07012, A07910		
Note:	The I_max reduction is not executed for PTC (p0601 = 1) or bimetallic NC contact (p0601 = 4). The I_max reduction results in a lower output frequency. If value = 0: An alarm is output and I_max is not reduced. For value = 1: An alarm is output and a timer is started. A fault is output if the alarm is still active after this timer has expired. - for KTY/PT1000, the following applies: I_max. is reduced - for PTC, the following is valid: I_max. is not reduced If value = 2: An alarm is output and a timer is started. A fault is output if the alarm is still active after this timer has expired. If value = 12: Behavior is always the same as for value 2. For motor temperature monitoring without temperature sensor, when switching off, the model temperature is saved in a non-volatile fashion. When switching on, the same value (reduced by p0614) is taken into account in the model calculation. As a consequence, the UL508C specification is fulfilled.		
p0611[0...n]	I2t motor model thermal time constant / I2t mot_mod T		
	Access level: 3	Calculated: -	Data type: FloatingPoint32
	Can be changed: C(1), U, T	Scaling: -	Dyn. index: DDS, p0180
	Unit group: -	Unit selection: -	Func. diagram: 8017
	Min	Max	Factory setting
	0 [s]	20000 [s]	0 [s]
Description:	Sets the winding time constant. The time constant specifies the warm-up time of the cold stator winding when loaded with the motor standstill current (rated motor current, if the motor standstill current is not parameterized) up until a temperature rise of 63 % of the continuously permissible winding temperature has been reached.		

Dependency: The parameter is only used for synchronous motors (p0300 = 2xx, 4) and synchronous reluctance motors (p0300 = 6xx).
Refer to: r0034, p0612, p0615
Refer to: F07011, A07012, A07910

Notice: This parameter is automatically pre-set from the motor database for motors from the motor list (p0301).
When selecting a catalog motor, this parameter cannot be changed (write protection). Information in p0300 should be carefully observed when removing write protection.
When exiting commissioning, p0612 is checked, and where relevant, is pre-assigned to a value that matches the motor power, if a temperature sensor was not parameterized (see p0601).

Note: When parameter p0611 is reset to 0, then this switches out the thermal I2t motor model (refer to p0612).
If no temperature sensor is parameterized, then the ambient temperature for the thermal motor model is referred to p0625.

p0612[0...n]	Mot_temp_mod activation / Mot_temp_mod act		
Access level: 2	Calculated: p0340 = 1	Data type: Unsigned16	
Can be changed: U, T	Scaling: -	Dyn. index: DDS, p0180	
Unit group: -	Unit selection: -	Func. diagram: 8017, 8018	
Min	Max	Factory setting	
-	-	0000 0010 0000 0010 bin	

Description: Setting to activate the motor temperature model.

Bit field:	Bit	Signal name	1 signal	0 signal	FP
	00	Activate mot_temp_mod 1 (I2t)	Yes	No	-
	01	Activate mot_temp_mod 2	Yes	No	-
	08	Activate mot_temp_mod 1 (I2t) extensions	Yes	No	-
	09	Activate mot_temp_mod 2 extensions	Yes	No	-
	12	Mot_temp_mod 1 (I2t) ambient temperature can be adjusted	Yes (via p0613)	No (fixed 20 °C)	-

Dependency: For synchronous motors and synchronous reluctance motors, when exiting commissioning, temperature model 1 is automatically activated if a time constant has been entered in p0611.
Refer to: r0034, p0604, p0605, p0606, p0611, p0613, p0615, p0625, p0626, p0627, p0628, r0630, r0631, r0632, r0633, p5350, r5389, p5390, p5391
Refer to: F07011, A07012, A07014, A07910

Notice: For bit 00:
This bit is only automatically activated for permanent-magnet 1FT7 synchronous motors and synchronous reluctance motors. For other permanent-magnet synchronous motors, the user himself must activate motor temperature model 1 (I2t).
It is only possible to activate this motor temperature model (I2t) for a time constant greater than zero (p0611 > 0).

2 Parameters

2.2 List of parameters

Note: Mot_temp_mod: motor temperature model

For bit 00:
This bit is used to activate/deactivate the motor temperature model for permanent-magnet synchronous motors and synchronous reluctance motors.

For bit 01 (see also bit 9):
This bit is used to activate/deactivate the motor temperature model for induction motors.

For bit 08:
This bit is used to extend the motor temperature model 1 (I2t).
The following applies for firmware version < 4.7 SP6 (only bit 0):
- this bit has no function. Temperature model 1 operates in the standard mode.
Overtemperature at rated load: p0605 - 40 °C
Alarm threshold: p0605
Fault threshold: p0615
The following applies from firmware version 4.7 SP6 (bits 0 and 8):
- temperature model 1 operates in the extended mode.
Overtemperature at rated load: p0627
Alarm threshold: p5390
Fault threshold: p5391

For bit 09:
This bit is used to extend the motor temperature model 2.
For firmware version < 4.7 following applies (only bit 1):
- this bit has no function. Temperature model 2 operates in the standard mode.
From firmware version 4.7 the following applies (bits 1 and 9):
- this bit should be set. Temperature model 2 then operates in the extended mode and the result of the model is more precise.

For bit 12 (only effective if a temperature sensor has not been parameterized):
This bit is used to set the ambient temperature for the motor temperature model 1 (I2t).
The following applies for firmware version < 4.7 SP6 (only bit 0):
- this bit has no function. Temperature model 1 operates with an ambient temperature of 20 °C.
The following applies from firmware version 4.7 SP6 (bits 0 and 12):
- the ambient temperature can be adapted to the conditions using p0613.

p0613[0...n]	Mot_temp_mod 1/3 ambient temperature / Mod 1/3 amb_temp		
Access level: 2	Calculated: -	Data type: FloatingPoint32	
Can be changed: U, T	Scaling: -	Dyn. index: DDS, p0180	
Unit group: 21_1	Unit selection: p0505	Func. diagram: 8017	
Min	Max	Factory setting	
-40 [°C]	100 [°C]	20 [°C]	

Description: Sets the ambient temperature for motor temperature model 1 or 3.
- temperature model 1 (I2t, p0612.0 = 1):
For firmware version < 4.7 SP6 or p0612.12 = 0, the following applies:
The parameter is not relevant.
From firmware version 4.7 SP6 and p0612.12 = 1, the following applies:
The parameter defines the current ambient temperature.
- temperature model 3 (p0612.2 = 1):
The parameter defines the current ambient temperature.

Dependency: Refer to: p0612
Refer to: F07011, A07012

p0614[0...n]	Thermal resistance adaptation reduction factor / Therm R_adapt red		
	Access level: 3	Calculated: -	Data type: FloatingPoint32
	Can be changed: U, T	Scaling: -	Dyn. index: DDS, p0180
	Unit group: -	Unit selection: -	Func. diagram: -
	Min	Max	Factory setting
	0 [%]	100 [%]	30 [%]
Description:	Sets the reduction factor for the overtemperature of the thermal adaptation of the stator/rotor resistance. The value is a starting value when switching on. Internally, after switch-on, the reduction factor has no effect corresponding to the thermal time constant.		
Dependency:	Refer to: p0610		
Note:	The reduction factor is only effective for p0610 = 12, and refers to the overtemperature.		
p0615[0...n]	Mot_temp_mod 1 (I2t) fault threshold / I2t F thresh		
	Access level: 2	Calculated: -	Data type: FloatingPoint32
	Can be changed: U, T	Scaling: -	Dyn. index: DDS, p0180
	Unit group: 21_1	Unit selection: p0505	Func. diagram: 8017
	Min	Max	Factory setting
	0.0 [°C]	220.0 [°C]	180.0 [°C]
Description:	Sets the fault threshold for monitoring the motor temperature for motor temperature model 1 (I2t). The following applies for firmware version < 4.7 SP6: - fault F07011 is output after the fault threshold is exceeded. - fault threshold for r0034 = $100 \% * (p0615 - 40) / (p0605 - 40)$. The following applies from firmware version 4.7 SP6 and p0612.8 = 1: - the fault threshold in p0615 is preset when commissioning. - when a catalog motor with motor temperature model 1 (I2t) is being commissioned for the first time, the threshold value is copied from p0615 to p5391. - p5391 is of significance for evaluating the fault threshold.		
Dependency:	The parameter is only used for motor temperature model 1 (I2t). Refer to: r0034, p0611, p0612 Refer to: F07011, A07012		
Notice:	When selecting a catalog motor (p0301), this parameter is automatically pre-assigned and is write protected. Information in p0300 should be carefully observed when removing write protection.		
Note:	The hysteresis is 2 K.		
p0620[0...n]	Thermal adaptation, stator and rotor resistance / Mot therm_adapt R		
	Access level: 4	Calculated: p0340 = 1	Data type: Integer16
	Can be changed: U, T	Scaling: -	Dyn. index: DDS, p0180
	Unit group: -	Unit selection: -	Func. diagram: -
	Min	Max	Factory setting
	0	2	1
Description:	Sets the thermal adaptation of the stator/primary section resistance and rotor/secondary section resistance according to r0395 and r0396.		
Value:	0: No thermal adaptation of stator and rotor resistances 1: Resistances adapted to the temperatures of the thermal model 2: Resistances adapted to the measured stator winding temperature		
Note:	For p0620 = 1, the following applies: The stator resistance is adapted using the temperature in r0035 and the rotor resistance together with the model temperature in r0633. For p0620 = 2, the following applies: The stator resistance is adapted using the temperature in r0035. If applicable, the rotor temperature for adapting the rotor resistance is calculated from the stator temperature (r0035) as follows: $\theta_R = (r0628 + r0625) / (r0627 + r0625) * r0035$		

p0621[0...n]	Identification stator resistance after restart / Rst_ident Restart		
	Access level: 2	Calculated: -	Data type: Integer16
	Can be changed: T	Scaling: -	Dyn. index: DDS, p0180
	Unit group: -	Unit selection: -	Func. diagram: -
	Min	Max	Factory setting
	0	2	0
Description:	<p>Selects the identification of the stator resistance of induction motors after the Control Unit runs-up (only for vector control).</p> <p>The identification is used to measure the actual stator resistance and from the ratio of the result of motor data identification (p0350) to the matching ambient temperature (p0625) the actual mean temperature of the stator winding is calculated. The result is used to initialize the thermal motor model.</p> <p>p0621 = 1: Identification of the stator resistance only when the drive is switched on for the first time (pulse enable) after booting the Control Unit.</p> <p>p0621 = 2: Identification of the stator resistance every time the drive is switched on (pulse enable).</p>		
Value:	<p>0: No Rs identification 1: Rs identification after switching-on again 2: Rs identification after switching-on each time</p>		
Dependency:	<p>- perform motor data identification (see p1910) with cold motor. - enter ambient temperature at time of motor data identification in p0625. Refer to: p0622, r0623</p>		
Notice:	<p>The determined stator temperature of the induction motor can only be compared with the measured value of a temperature sensor (KTY/PT1000) to a certain extent, as the sensor is usually the warmest point of the stator winding, whereas the measured value of identification reflects the mean value of the stator winding.</p> <p>Furthermore this is a short-time measurement with limited accuracy that is performed during the magnetizing phase of the induction motor.</p>		
Note:	<p>The measurement is carried out:</p> <ul style="list-style-type: none"> - For induction motors - When vector control is active (see p1300) - if a temperature sensor (KTY/PT1000) has not been connected - When the motor is at a standstill when switched on <p>When a flying restart is performed on a rotating motor, the temperatures of the thermal motor model are set to a third of the overtemperatures. This occurs only once, however, when the CU is booted (e.g. after a power failure).</p> <p>If identification is activated, the magnetizing time is determined via p0622 and not via p0346. Quick magnetizing (p1401.6) is de-energized internally and alarm A07416 is displayed. The speed is enabled after completion of the measurement.</p>		
p0622[0...n]	Motor excitation time for Rs_ident after switching on again / t_excit Rs_id		
	Access level: 3	Calculated: p0340 = 1,3	Data type: FloatingPoint32
	Can be changed: U, T	Scaling: -	Dyn. index: DDS, p0180
	Unit group: -	Unit selection: -	Func. diagram: -
	Min	Max	Factory setting
	0.000 [s]	20.000 [s]	0.000 [s]
Description:	Sets the excitation time of the motor for the stator resistance identification after switching on again (restart).		
Dependency:	Refer to: p0621, r0623		
Note:	<p>For p0622 < p0346 the following applies:</p> <p>If identification is activated, the magnetizing time is influenced by p0622. The speed is enabled after measurement is complete, but not before the time in p0346 has elapsed (see r0056 bit 4). The time taken for measurement also depends on the settling time of the measured current.</p> <p>For p0622 >= p0346 the following applies:</p> <p>Parameter p0622 is internally limited to the magnetizing time p0346, so that p0346 represents the maximum possible magnetizing time during identification. The entire measurement period (magnetizing plus measurement settling time plus measuring time) will always be greater than p0346.</p>		

p0623	Rs identification stator resistance after switch on again / Rs-id Rs aft sw-on		
	Access level: 4	Calculated: -	Data type: FloatingPoint32
	Can be changed: -	Scaling: -	Dyn. index: -
	Unit group: -	Unit selection: -	Func. diagram: -
	Min	Max	Factory setting
	- [ohm]	- [ohm]	- [ohm]
Description:	Displays the stator resistance determined using the Rs identification after switching on again.		
Dependency:	Refer to: p0621, p0622		
p0625[0...n]	Motor ambient temperature during commissioning / Mot T_ambient		
	Access level: 3	Calculated: p0340 = 1,2	Data type: FloatingPoint32
	Can be changed: U, T	Scaling: -	Dyn. index: DDS, p0180
	Unit group: 21_1	Unit selection: p0505	Func. diagram: 8017, 8018
	Min	Max	Factory setting
	-40 [°C]	80 [°C]	20 [°C]
Description:	Defines the ambient temperature of the motor for calculating the motor temperature model.		
Dependency:	Refer to: p0350, p0354		
Note:	The parameters for stator and rotor resistance (p0350, p0354) refer to this temperature. If the thermal I2t motor model is activated for permanent-magnet synchronous motors (refer to p0611), p0625 is included in the model calculation if a temperature sensor is not being used (see p0601).		
p0626[0...n]	Motor overtemperature, stator core / Mot T_over core		
	Access level: 4	Calculated: p0340 = 1,2	Data type: FloatingPoint32
	Can be changed: U, T	Scaling: -	Dyn. index: DDS, p0180
	Unit group: 21_2	Unit selection: p0505	Func. diagram: 8018
	Min	Max	Factory setting
	10 [K]	200 [K]	50 [K]
Description:	Defines the rated overtemperature of the stator iron referred to ambient temperature in the motor temperature model 2 (p0612.1 = 1).		
Dependency:	For 1LA7 motors (p0300), the parameter is pre-set as a function of p0307 and p0311. Refer to: p0625		
Notice:	When selecting a standard induction motor listed in the catalog (p0300 > 100, p0301 > 10000), this parameter is automatically pre-assigned and is write protected. Information in p0300 should be carefully observed when removing write protection.		
Note:	When quick commissioning is exited with p3900 > 0, then the parameter is reset if a catalog motor has not been selected (p0300).		
p0627[0...n]	Motor overtemperature, stator winding / Mot T_over stator		
	Access level: 2	Calculated: p0340 = 1,2	Data type: FloatingPoint32
	Can be changed: U, T	Scaling: -	Dyn. index: DDS, p0180
	Unit group: 21_2	Unit selection: p0505	Func. diagram: 8017, 8018
	Min	Max	Factory setting
	15 [K]	200 [K]	80 [K]
Description:	Defines the rated overtemperature of the stator winding referred to the ambient temperature. - motor temperature model 1 (I2t, p0612.0 = 1): The following applies for firmware version < 4.7 SP6 or p0612.8 = 0: p0605 is of significance for the rated temperature. The following applies from firmware version 4.7 SP6 and p0612.8 = 1: Overtemperature at the rated operating point. - motor temperature model 2 (p0612.1 = 1): Overtemperature at the rated operating point.		
Dependency:	For 1LA7 motors (p0300), the parameter is pre-set as a function of p0307 and p0311. Refer to: p0625		

2 Parameters

2.2 List of parameters

Notice: When selecting a standard induction motor listed in the catalog (p0300 > 100, p0301 > 10000), this parameter is automatically pre-assigned and is write protected. Information in p0300 should be carefully observed when removing write protection.

Note: When quick commissioning is exited with p3900 > 0, then the parameter is reset if a catalog motor has not been selected (p0300).
The signal is not suitable as a process quantity and may only be used as a display quantity.

p0628[0...n]	Motor overtemperature rotor / Mot T_{over} rotor		
	Access level: 4	Calculated: p0340 = 1,2	Data type: FloatingPoint32
	Can be changed: U, T	Scaling: -	Dyn. index: DDS, p0180
	Unit group: 21_2	Unit selection: p0505	Func. diagram: 8018
	Min	Max	Factory setting
	20 [K]	200 [K]	100 [K]
Description:	Defines the rated overtemperature of the squirrel cage rotor referred to ambient temperature in the motor temperature model 2 (p0612.1 = 1).		
Dependency:	For 1LA7 motors (p0300), the parameter is pre-set as a function of p0307 and p0311. Refer to: p0625		
Notice:	When selecting a standard induction motor listed in the catalog (p0300 > 100, p0301 > 10000), this parameter is automatically pre-assigned and is write protected. Information in p0300 should be carefully observed when removing write protection.		
Note:	When quick commissioning is exited with p3900 > 0, then the parameter is reset if a catalog motor has not been selected (p0300).		

r0630[0...n]	Mot_{temp}_mod ambient temperature / Mod T_{ambient}		
	Access level: 4	Calculated: -	Data type: FloatingPoint32
	Can be changed: -	Scaling: p2006	Dyn. index: DDS, p0180
	Unit group: 21_1	Unit selection: p0505	Func. diagram: 8018
	Min	Max	Factory setting
	- [°C]	- [°C]	- [°C]
Description:	Displays the ambient temperature of the motor temperature model (models 2 and 3).		

r0631[0...n]	Mot_{temp}_mod stator iron temperature / Mod T_{stator}		
	Access level: 4	Calculated: -	Data type: FloatingPoint32
	Can be changed: -	Scaling: p2006	Dyn. index: DDS, p0180
	Unit group: 21_1	Unit selection: p0505	Func. diagram: 8018
	Min	Max	Factory setting
	- [°C]	- [°C]	- [°C]
Description:	Displays the stator iron temperature of the motor temperature model (models 2 and 3).		
Note:	For motor temperature model 1 (p0612.0 = 1), this parameter is not valid:		

r0632[0...n]	Mot_{temp}_mod stator winding temperature / Mod T_{winding}		
	Access level: 2	Calculated: -	Data type: FloatingPoint32
	Can be changed: -	Scaling: p2006	Dyn. index: DDS, p0180
	Unit group: 21_1	Unit selection: p0505	Func. diagram: 8017, 8018
	Min	Max	Factory setting
	- [°C]	- [°C]	- [°C]
Description:	Displays the stator winding temperature of the motor temperature model.		
Dependency:	Refer to: F07011, A07012, A07910		

r0633[0...n]	Mot_temp_mod rotor temperature / Mod rotor temp		
	Access level: 4	Calculated: -	Data type: FloatingPoint32
	Can be changed: -	Scaling: p2006	Dyn. index: DDS, p0180
	Unit group: 21_1	Unit selection: p0505	Func. diagram: 8018
	Min	Max	Factory setting
	- [°C]	- [°C]	- [°C]
Description:	Displays the rotor temperature of the motor temperature model (models 2 and 3).		
Note:	For motor temperature model 1 (p0612.0 = 1), this parameter is not valid:		
p0640[0...n]	Current limit / Current limit		
	Access level: 2	Calculated: p0340 = 1	Data type: FloatingPoint32
	Can be changed: C(1), U, T	Scaling: -	Dyn. index: DDS, p0180
	Unit group: -	Unit selection: -	Func. diagram: 6640
	Min	Max	Factory setting
	0.00 [Arms]	10000.00 [Arms]	0.00 [Arms]
Description:	Sets the current limit.		
Dependency:	Refer to: r0209, p0323		
Note:	The parameter is part of the quick commissioning (p0010 = 1); this means that it is appropriately pre-assigned when changing p0305. The current limit p0640 is limited to r0209. The resulting current limit is displayed in r0067 and if required, r0067 is reduced by the thermal model of the power unit. The torque and power limits (p1520, p1521, p1530, p1531) matching the current limit are automatically calculated when exiting the quick commissioning using p3900 > 0 or using the automatic parameterization with p0340 = 3, 5. p0640 is limited to 4.0 x p0305. p0640 is pre-assigned for the automatic self commissioning routine (e.g. to 1.5 x p0305, with p0305 = r0207[1]). p0640 must be entered when commissioning the system. This is the reason that p0640 is not calculated by the automatic parameterization when exiting the quick commissioning (p3900 > 0).		
p0641[0...n]	CI: Current limit, variable / Curr lim var		
	Access level: 3	Calculated: -	Data type: U32 / FloatingPoint32
	Can be changed: T	Scaling: PERCENT	Dyn. index: CDS, p0170
	Unit group: -	Unit selection: -	Func. diagram: 6640
	Min	Max	Factory setting
	-	-	1
Description:	Sets the signal source for the variable current limit. The value is referred to p0640.		
p0650[0...n]	Actual motor operating hours / Oper hours motor		
	Access level: 3	Calculated: -	Data type: Unsigned32
	Can be changed: T	Scaling: -	Dyn. index: DDS, p0180
	Unit group: -	Unit selection: -	Func. diagram: -
	Min	Max	Factory setting
	0 [h]	4294967295 [h]	0 [h]
Description:	Displays the operating hours for the corresponding motor. The motor operating time counter continues to run when the pulses are enabled. When the pulse enable is withdrawn, the counter is held and the value saved.		
Dependency:	Refer to: p0651 Refer to: A01590		
Note:	For p0651 = 0, the operating hours counter is disabled. The operating hours counter in p0650 can only be reset to 0. The operating hours counter only runs with drive data set 0 and 1 (DDS).		

p0651[0...n]	Motor operating hours maintenance interval / Mot t_op maint				
	Access level: 3	Calculated: -	Data type: Unsigned32		
	Can be changed: T	Scaling: -	Dyn. index: DDS, p0180		
	Unit group: -	Unit selection: -	Func. diagram: -		
	Min	Max	Factory setting		
	0 [h]	150000 [h]	0 [h]		
Description:	Sets the service/maintenance intervals in hours for the appropriate motor. An appropriate message is output when the operating hours set here are reached.				
Dependency:	Refer to: p0650 Refer to: A01590				
Note:	For p0651 = 0, the operating hours counter is disabled. When setting p0651 to 0, then p0650 is automatically set to 0. The operating hours counter only runs with drive data set 0 and 1 (DDS). If there is no temperature monitor, then interconnect to a fixed value. For index [3]: When the binector input is interconnected, precharging is switched-on independent of the magnitude of the precharging threshold.				
r0720[0...4]	CU number of inputs and outputs / CU I/O count				
	Access level: 3	Calculated: -	Data type: Unsigned16		
	Can be changed: -	Scaling: -	Dyn. index: -		
	Unit group: -	Unit selection: -	Func. diagram: 2119		
	Min	Max	Factory setting		
	-	-	-		
Description:	Displays the number of inputs and outputs.				
Index:	[0] = Number of digital inputs [1] = Number of digital outputs [2] = Number of digital input/outputs bidirectional [3] = Number of analog inputs [4] = Number of analog outputs				
r0721	CU digital inputs terminal actual value / CU DI term act val				
	Access level: 2	Calculated: -	Data type: Unsigned32		
	Can be changed: -	Scaling: -	Dyn. index: -		
	Unit group: -	Unit selection: -	Func. diagram: 2119, 2120, 2121, 2130, 2131, 2132, 2133		
	Min	Max	Factory setting		
	-	-	-		
Description:	Displays the actual value at the digital inputs. This means that the actual input signal can be checked at terminal DI x or DI/DO x prior to switching from the simulation mode (p0795.x = 1) to terminal mode (p0795.x = 0).				
Bit field:	Bit	Signal name	1 signal	0 signal	FP
	00	DI 0 (X500.4)	High	Low	-
	01	DI 1 (X500.3)	High	Low	-
	02	DI 2 (X501.4)	High	Low	-
	03	DI 3 (X501.3)	High	Low	-
	24	DI/DO 24 (X502.4)	High	Low	-
	25	DI/DO 25 (X502.3)	High	Low	-
Note:	If a DI/DO is parameterized as output (p0728.x = 1), then r0721.x = 0 is displayed. DI: Digital Input DI/DO: Bidirectional Digital Input/Output				

r0722.0...25	CO/BO: CU digital inputs status / CU DI status				
	Access level: 1	Calculated: -	Data type: Unsigned32		
	Can be changed: -	Scaling: -	Dyn. index: -		
	Unit group: -	Unit selection: -	Func. diagram: 2119, 2120, 2121, 2130, 2131, 2132, 2133		
	Min	Max	Factory setting		
	-	-	-		
Description:	Displays the status of the digital inputs.				
Bit field:	Bit	Signal name	1 signal	0 signal	FP
	00	DI 0 (X500.4)	High	Low	-
	01	DI 1 (X500.3)	High	Low	-
	02	DI 2 (X501.4)	High	Low	-
	03	DI 3 (X501.3)	High	Low	-
	24	DI/DO 24 (X502.4)	High	Low	-
	25	DI/DO 25 (X502.3)	High	Low	-
Dependency:	Refer to: r0723				
Note:	DI: Digital Input DI/DO: Bidirectional Digital Input/Output				

r0723.0...25	CO/BO: CU digital inputs status inverted / CU DI status inv				
	Access level: 1	Calculated: -	Data type: Unsigned32		
	Can be changed: -	Scaling: -	Dyn. index: -		
	Unit group: -	Unit selection: -	Func. diagram: 2119, 2120, 2121, 2130, 2131, 2132, 2133		
	Min	Max	Factory setting		
	-	-	-		
Description:	Displays the inverted status of the digital inputs.				
Bit field:	Bit	Signal name	1 signal	0 signal	FP
	00	DI 0 (X500.4)	High	Low	-
	01	DI 1 (X500.3)	High	Low	-
	02	DI 2 (X501.4)	High	Low	-
	03	DI 3 (X501.3)	High	Low	-
	24	DI/DO 24 (X502.4)	High	Low	-
	25	DI/DO 25 (X502.3)	High	Low	-
Dependency:	Refer to: r0722				
Note:	DI: Digital Input DI/DO: Bidirectional Digital Input/Output				

p0724	CU digital inputs debounce time / CU DI t_debounce			
	Access level: 3	Calculated: -	Data type: FloatingPoint32	
	Can be changed: U, T	Scaling: -	Dyn. index: -	
	Unit group: -	Unit selection: -	Func. diagram: -	
	Min	Max	Factory setting	
	0.000 [ms]	20.000 [ms]	4.000 [ms]	
Description:	Sets the debounce time for digital inputs.			
Note:	The digital inputs are read in cyclically every 2 ms (DI 11, DI 12 every 4 ms). To debounce the signals, the set debounce time is converted into integer multiple debounce clock cycles Tp (Tp = p0724 / 2 ms). DI: Digital Input			

r0727 Quick commissioning DIP switch status / Comm DIP status					
Access level:	3	Calculated:	-	Data type: Unsigned32	
Can be changed:	-	Scaling:	-	Dyn. index: -	
Unit group:	-	Unit selection:	-	Func. diagram: 2280	
Min	-	Max	-	Factory setting	
Description:	Displays the status of the individual commissioning DIP switches of switch blocks DIP1 and DIP2.				
Bit field:	Bit	Signal name	1 signal	0 signal	FP
	00	DIP1.1 temperature sensor type	ON	OFF	-
	01	DIP2.8 reserved	ON	OFF	-
	02	DIP1.4 pulse frequency	ON	OFF	-
	03	DIP1.7 reserved	ON	OFF	-
	04	DIP1.8 reserved	ON	OFF	-
	05	DIP1.3 motor holding brake	ON	OFF	-
	06	DIP1.6 87 Hz operation	ON	OFF	-
	07	DIP2.1 ramp-up/ramp-down time bit 0	ON	OFF	-
	08	DIP2.2 ramp-up/ramp-down time bit 1	ON	OFF	-
	09	DIP2.3 ramp-up/ramp-down time bit 2	ON	OFF	-
	10	DIP2.4 ramp-up/ramp-down time bit 3	ON	OFF	-
	11	DIP1.2 invert output phase sequence	ON	OFF	-
	12	DIP1.5 motor type	ON	OFF	-
	13	DIP2.5 macro selection bit 0	ON	OFF	-
	14	DIP2.6 macro selection bit 1	ON	OFF	-
	15	DIP2.7 macro selection bit 2	ON	OFF	-
	16	G115D mounting type	Motor	Wall/panel	-

Note:

For bit 00 (temperature sensor type):

- bit 0 = 0 --> temperature sensor type not set via DIP switch, can be set via p0601
- bit 0 = 1 --> PT1000 (DIP switch active, p0601 can only be read, p0601 = 6 is displayed)

For bit 02 (pulse frequency):

- bit 2 = 0 --> pulse frequency not set via DIP switch, can be set via p1800
- bit 2 = 1 --> 16 kHz (DIP switch active, p1800 can only be read, and indicates the pulse frequency that has been set)

For bit 05 (motor holding brake):

- bit 5 = 0 --> motor holding brake not set using DIP switch, can be set using p1215
- bit 5 = 1 --> motor holding brake available (DIP switch effective, p1215 can only be read, p1215 = 1 is displayed)

For bit 06 (87 Hz operation):

- bit 6 = 0 --> 87 Hz operation not set via DIP switch, can be set via p0133.0/.1
- bit 6 = 1 --> 87 Hz operation (DIP switch effective, p0133.0/.1 can only be read, p0133.0/.1 = 1 is displayed)

For bits 10, 09, 08, 07 (ramp-up/ramp-down time):

- bits 10, 9, 8, 7 = 0, 0, 0, 0 --> ramp-up/ramp-down time not set via DIP switch, can be set via p1120/p1121/p1138/p1139
- bits 10, 9, 8, 7 = 0, 0, 0, 1 --> 0.1 s (DIP switch effective, p1120/p1121/p1138/p1139 can only be read)
- bits 10, 9, 8, 7 = 0, 0, 1, 0 --> 0.2 s (DIP switch effective, p1120/p1121/p1138/p1139 can only be read)
- bits 10, 9, 8, 7 = 0, 0, 1, 1 --> 0.3 s (DIP switch effective, p1120/p1121/p1138/p1139 can only be read)
- bits 10, 9, 8, 7 = 0, 1, 0, 0 --> 0.5 s (DIP switch effective, p1120/p1121/p1138/p1139 can only be read)
- bits 10, 9, 8, 7 = 0, 1, 0, 1 --> 0.7 s (DIP switch effective, p1120/p1121/p1138/p1139 can only be read)
- bits 10, 9, 8, 7 = 0, 1, 1, 0 --> 1 s (DIP switch effective, p1120/p1121/p1138/p1139 can only be read)
- bits 10, 9, 8, 7 = 0, 1, 1, 1 --> 2 s (DIP switch effective, p1120/p1121/p1138/p1139 can only be read)
- bits 10, 9, 8, 7 = 1, 0, 0, 0 --> 3 s (DIP switch effective, p1120/p1121/p1138/p1139 can only be read)
- bits 10, 9, 8, 7 = 1, 0, 0, 1 --> 5 s (DIP switch effective, p1120/p1121/p1138/p1139 can only be read)
- bits 10, 9, 8, 7 = 1, 0, 1, 0 --> 7 s (DIP switch effective, p1120/p1121/p1138/p1139 can only be read)
- bits 10, 9, 8, 7 = 1, 0, 1, 1 --> 10 s (DIP switch effective, p1120/p1121/p1138/p1139 can only be read)
- bits 10, 9, 8, 7 = 1, 1, 0, 0 --> 20 s (DIP switch effective, p1120/p1121/p1138/p1139 can only be read)
- bits 10, 9, 8, 7 = 1, 1, 0, 1 --> 30 s (DIP switch effective, p1120/p1121/p1138/p1139 can only be read)
- bits 10, 9, 8, 7 = 1, 1, 1, 0 --> 50 s (DIP switch effective, p1120/p1121/p1138/p1139 can only be read)
- bits 10, 9, 8, 7 = 1, 1, 1, 1 --> 70 s (DIP switch effective, p1120/p1121/p1138/p1139 can only be read)

For bit 11 (invert output phase sequence):

- bit 11 = 0 --> invert output phase sequence not set via DIP switch, can be set using p1820
- bit 11 = 1 --> invert output phase sequence for motor (DIP switch active, p1820 can only be read, p1820 = 1 is displayed)

For bit 12 (motor type):

- bit 11 = 0 --> induction motor (p0300, p0301) can be set
- bit 11 = 1 --> reluctance motor (p0300, p0301) can be set

For bits 15, 14, 13 (macros):

I/O version:

- bits 15, 14, 13 = 0, 0, 0 --> factory setting = 65 or set the same as p0015
- Bits 15, 14, 13 = 0, 0, 1 --> p0015 = 9*
- Bits 15, 14, 13 = 0, 1, 0 --> p0015 = 60*
- Bits 15, 14, 13 = 0, 1, 1 --> p0015 = 61*
- Bits 15, 14, 13 = 1, 0, 0 --> p0015 = 62*
- Bits 15, 14, 13 = 1, 0, 1 --> p0015 = 63*
- Bits 15, 14, 13 = 1, 1, 0 --> p0015 = 64*
- Bits 15, 14, 13 = 1, 1, 1 --> p0015 = not used**

* Parameterization via Startdrive / SAM blocked

**This DIP switch setting is not used, p0015 is set to the factory setting p0015=65. Macro setting via Startdrive or SAM not possible.

PN variant:

- bits 15, 14, 13 = 0, 0, 0 --> factory setting = 67 or set the same as p0015

AS-i version:

- bits 15, 14, 13 = 0, 0, 0 --> factory setting p0015 = 30, macro setting possible via Startdrive or SAM
- bits 15, 14, 13 = 0, 0, 1 --> p0015 = 31*

2 Parameters

2.2 List of parameters

- bits 15, 14, 13 = 0, 1, 0 --> p0015 = 34*
- bits 15, 14, 13 = 0, 1, 1 --> p0015 = 66*
- bits 15, 14, 13 = 1, 0, 0 --> not used**
- bits 15, 14, 13 = 1, 0, 1 --> not used**
- bits 15, 14, 13 = 1, 1, 0 --> not used**
- bits 15, 14, 13 = 1, 1, 1 --> not used**

* Parameterization via Startdrive / SAM blocked

**This DIP switch setting is not used, p0015 is set to the factory setting p0015=30. Macro setting via Startdrive or SAM not possible.

For bit 16 (mounting type):

- bit 16 = 0 --> G115D wall/panel-mounted
- bit 16 = 1 --> G115D motor-mounted

p0728		CU set input or output / CU DI or DO		
G115D I/O	Access level: 1	Calculated: -	Data type: Unsigned32	
	Can be changed: T	Scaling: -	Dyn. index: -	
	Unit group: -	Unit selection: -	Func. diagram: 2119, 2030, 2031, 2130, 2131, 2132, 2133	
	Min	Max	Factory setting	
	-	-	0000 0011 0000 0000 0000 0000 0000 0000 0000 bin	
Description:	Sets the bidirectional digital inputs/outputs as an input or output.			
Bit field:	Bit	Signal name	1 signal	0 signal
	24	DI24/DO24 (X502.4)	Output	Input
	25	DI25/DO25 (X502.3)	Output	Input
Note:	DI/DO: Bidirectional Digital Input/Output			

p0728		CU set input or output / CU DI or DO		
G115D PN	Access level: 1	Calculated: -	Data type: Unsigned32	
G115D ASI	Can be changed: T	Scaling: -	Dyn. index: -	
	Unit group: -	Unit selection: -	Func. diagram: 2119, 2030, 2031, 2130, 2131, 2132, 2133	
	Min	Max	Factory setting	
	-	-	0000 0000 0000 0000 0000 0000 0000 0000 0000 bin	
Description:	Sets the bidirectional digital inputs/outputs as an input or output.			
Bit field:	Bit	Signal name	1 signal	0 signal
	24	DI24/DO24 (X502.4)	Output	Input
	25	DI25/DO25 (X502.3)	Output	Input
Note:	DI/DO: Bidirectional Digital Input/Output			

p0738		BI: CU signal source for terminal DI/DO 24 / CU s_s DI/DO 24		
G115D ASI	Access level: 1	Calculated: -	Data type: U32 / Binary	
	Can be changed: U, T	Scaling: -	Dyn. index: -	
	Unit group: -	Unit selection: -	Func. diagram: 2201, 2230	
	Min	Max	Factory setting	
	-	-	0	
Description:	Sets the signal source for terminal DI/DO 24.			
Notice:	The parameter may be protected as a result of p0922 or p2079 and cannot be changed.			
Note:	Prerequisite: The DI/DO must be set as an output (p0728.24 = 1). DI/DO: Bidirectional Digital Input/Output			

p0738	BI: CU signal source for terminal DI/DO 24 / CU s_s DI/DO 24		
G115D I/O	Access level: 1	Calculated: -	Data type: U32 / Binary
	Can be changed: U, T	Scaling: -	Dyn. index: -
	Unit group: -	Unit selection: -	Func. diagram: 2201, 2230
	Min	Max	Factory setting
	-	-	52.3
Description:	Sets the signal source for terminal DI/DO 24.		
Notice:	The parameter may be protected as a result of p0922 or p2079 and cannot be changed.		
Note:	Prerequisite: The DI/DO must be set as an output (p0728.24 = 1). DI/DO: Bidirectional Digital Input/Output		

p0738	BI: CU signal source for terminal DI/DO 24 / CU s_s DI/DO 24		
G115D PN	Access level: 1	Calculated: -	Data type: U32 / Binary
	Can be changed: U, T	Scaling: -	Dyn. index: -
	Unit group: -	Unit selection: -	Func. diagram: 2201, 2230
	Min	Max	Factory setting
	-	-	2094.0
Description:	Sets the signal source for terminal DI/DO 24.		
Notice:	The parameter may be protected as a result of p0922 or p2079 and cannot be changed.		
Note:	Prerequisite: The DI/DO must be set as an output (p0728.24 = 1). DI/DO: Bidirectional Digital Input/Output		

p0739	BI: CU signal source for terminal DI/DO 25 / CU s_s DI/DO 25		
G115D ASI	Access level: 1	Calculated: -	Data type: U32 / Binary
	Can be changed: U, T	Scaling: -	Dyn. index: -
	Unit group: -	Unit selection: -	Func. diagram: 2230
	Min	Max	Factory setting
	-	-	0
Description:	Sets the signal source for terminal DI/DO 25.		
Notice:	The parameter may be protected as a result of p0922 or p2079 and cannot be changed.		
Note:	Prerequisite: The DI/DO must be set as an output (p0728.25 = 1). DI/DO: Bidirectional Digital Input/Output		

p0739	BI: CU signal source for terminal DI/DO 25 / CU s_s DI/DO 25		
G115D I/O	Access level: 1	Calculated: -	Data type: U32 / Binary
	Can be changed: U, T	Scaling: -	Dyn. index: -
	Unit group: -	Unit selection: -	Func. diagram: 2230
	Min	Max	Factory setting
	-	-	52.7
Description:	Sets the signal source for terminal DI/DO 25.		
Notice:	The parameter may be protected as a result of p0922 or p2079 and cannot be changed.		
Note:	Prerequisite: The DI/DO must be set as an output (p0728.25 = 1). DI/DO: Bidirectional Digital Input/Output		

p0739	BI: CU signal source for terminal DI/DO 25 / CU s_s DI/DO 25		
G115D PN	Access level: 1	Calculated: -	Data type: U32 / Binary
	Can be changed: U, T	Scaling: -	Dyn. index: -
	Unit group: -	Unit selection: -	Func. diagram: 2230
	Min	Max	Factory setting
	-	-	2094.1
Description:	Sets the signal source for terminal DI/DO 25.		
Notice:	The parameter may be protected as a result of p0922 or p2079 and cannot be changed.		

2 Parameters

2.2 List of parameters

Note: Prerequisite: The DI/DO must be set as an output (p0728.25 = 1).
DI/DO: Bidirectional Digital Input/Output

r0747	CU digital outputs status / CU DO status			
	Access level: 1	Calculated: -	Data type: Unsigned32	
	Can be changed: -	Scaling: -	Dyn. index: -	
	Unit group: -	Unit selection: -	Func. diagram: 2130, 2131, 2132, 2133	
	Min	Max	Factory setting	
	-	-	-	
Description:	Displays the status of digital outputs.			
Bit field:	Bit	Signal name	1 signal	0 signal
	24	DI/DO 24 (X502.4)	High	Low
	25	DI/DO 25 (X502.3)	High	Low
Note:	Inversion using p0748 has been taken into account. DI/DO: Bidirectional Digital Input/Output			

p0748	CU invert digital outputs / CU DO inv			
	Access level: 1	Calculated: -	Data type: Unsigned32	
	Can be changed: U, T	Scaling: -	Dyn. index: -	
	Unit group: -	Unit selection: -	Func. diagram: 2030, 2031, 2130, 2131, 2132, 2133	
	Min	Max	Factory setting	
	-	-	0000 0000 0000 0000 0000 0000 0000 0000 bin	
Description:	Setting to invert the signals at the digital outputs.			
Bit field:	Bit	Signal name	1 signal	0 signal
	24	DI/DO 24 (X502.4)	High	Low
	25	DI/DO 25 (X502.3)	High	Low
Note:	DI/DO: Bidirectional Digital Input/Output			

r0752[0...1]	CO: CU analog inputs input voltage/current actual / CU AI U/I_inp act			
	Access level: 2	Calculated: -	Data type: FloatingPoint32	
	Can be changed: -	Scaling: p0514	Dyn. index: -	
	Unit group: -	Unit selection: -	Func. diagram: 2251	
	Min	Max	Factory setting	
	-	-	-	
Description:	Displays the actual input voltage in V when set as voltage input.			
Index:	[0] = Motor speed potentiometer 1 [1] = Motor speed potentiometer 2			
Note:	AI are the potentiometers			

p0753[0...1]	CU analog inputs smoothing time constant / CU AI T_smooth			
	Access level: 3	Calculated: -	Data type: FloatingPoint32	
	Can be changed: U, T	Scaling: -	Dyn. index: -	
	Unit group: -	Unit selection: -	Func. diagram: 2251	
	Min	Max	Factory setting	
	0.0 [ms]	1000.0 [ms]	0.0 [ms]	
Description:	Sets the smoothing time constant of the 1st order lowpass filter for the potentiometer.			
Index:	[0] = Motor speed potentiometer 1 [1] = Motor speed potentiometer 2			

r0755[0...1]	CO: CU analog inputs actual value in percent / CU AI value in %		
	Access level: 2	Calculated: -	Data type: FloatingPoint32
	Can be changed: -	Scaling: PERCENT	Dyn. index: -
	Unit group: -	Unit selection: -	Func. diagram: 2201, 2251
	Min	Max	Factory setting
	- [%]	- [%]	- [%]
Description:	Displays the currently referred input value of the potentiometer. When interconnected, the signals are referred to the reference quantities p200x and p205x.		
Index:	[0] = Motor speed potentiometer 1 [1] = Motor speed potentiometer 2		
Note:	AI are the potentiometers		

p0757[0...1]	CU analog inputs characteristic value x1 / CU AI char x1		
	Access level: 2	Calculated: -	Data type: FloatingPoint32
	Can be changed: U, T	Scaling: -	Dyn. index: -
	Unit group: -	Unit selection: -	Func. diagram: 2251
	Min	Max	Factory setting
	-50.000	160.000	0.000
Description:	Sets the scaling characteristic for the analog inputs. The scaling characteristic for the analog inputs is defined using 2 points. This parameter specifies the x coordinate (V) of the 1st value pair of the characteristic.		
Index:	[0] = Motor speed potentiometer 1 [1] = Motor speed potentiometer 2		
Note:	The parameters for the characteristic do not have a limiting effect.		

p0758[0...1]	CU analog inputs characteristic value y1 / CU AI char y1		
	Access level: 2	Calculated: -	Data type: FloatingPoint32
	Can be changed: U, T	Scaling: -	Dyn. index: -
	Unit group: -	Unit selection: -	Func. diagram: 2251
	Min	Max	Factory setting
	-1000.00 [%]	1000.00 [%]	0.00 [%]
Description:	Sets the scaling characteristic for the analog inputs. The scaling characteristic for the analog inputs is defined using 2 points. This parameter specifies the y coordinate (percentage) of the 1st value pair of the characteristic.		
Index:	[0] = Motor speed potentiometer 1 [1] = Motor speed potentiometer 2		
Note:	The parameters for the characteristic do not have a limiting effect.		

p0759[0...1]	CU analog inputs characteristic value x2 / CU AI char x2		
	Access level: 2	Calculated: -	Data type: FloatingPoint32
	Can be changed: U, T	Scaling: -	Dyn. index: -
	Unit group: -	Unit selection: -	Func. diagram: 2251
	Min	Max	Factory setting
	-50.000	160.000	3.300
Description:	Sets the scaling characteristic for the analog inputs. The scaling characteristic for the analog inputs is defined using 2 points. This parameter specifies the x coordinate (V) of the 2nd value pair of the characteristic.		
Index:	[0] = Motor speed potentiometer 1 [1] = Motor speed potentiometer 2		
Note:	The parameters for the characteristic do not have a limiting effect.		

p0760[0...1]	CU analog inputs characteristic value y2 / CU AI char y2		
	Access level: 2	Calculated: -	Data type: FloatingPoint32
	Can be changed: U, T	Scaling: -	Dyn. index: -
	Unit group: -	Unit selection: -	Func. diagram: 2251
	Min	Max	Factory setting
	-1000.00 [%]	1000.00 [%]	100.00 [%]
Description:	Sets the scaling characteristic for the analog inputs. The scaling characteristic for the analog inputs is defined using 2 points. This parameter specifies the y coordinate (percentage) of the 2nd value pair of the characteristic.		
Index:	[0] = Motor speed potentiometer 1 [1] = Motor speed potentiometer 2		
Note:	The parameters for the characteristic do not have a limiting effect.		
p0761[0...1]	CU analog inputs wire breakage monitoring response threshold / CU WireBrkThresh		
	Access level: 2	Calculated: -	Data type: FloatingPoint32
	Can be changed: U, T	Scaling: -	Dyn. index: -
	Unit group: -	Unit selection: -	Func. diagram: 2251
	Min	Max	Factory setting
	0.00	20.00	0.30
Description:	Sets the response threshold for the wire breakage monitoring of the potentiometer.		
Index:	[0] = Motor speed potentiometer 1 [1] = Motor speed potentiometer 2		
Dependency:	For the following potentiometer type, wire breakage monitoring is active: p0756[0...1] = 1 (voltage input is monitored for one polarity only (+0.3V ... +3V)), unit [V]		
p0762[0...1]	CU analog inputs wire breakage monitoring delay time / CU wire brk t_del		
	Access level: 3	Calculated: -	Data type: Unsigned16
	Can be changed: U, T	Scaling: -	Dyn. index: -
	Unit group: -	Unit selection: -	Func. diagram: 2251
	Min	Max	Factory setting
	0 [ms]	1000 [ms]	100 [ms]
Description:	Sets the delay time for the wire breakage monitoring of the analog inputs.		
Index:	[0] = Motor speed potentiometer 1 [1] = Motor speed potentiometer 2		
Dependency:	For the following potentiometer type, wire breakage monitoring is active: p0756[0...1] = 1 (voltage input is monitored for one polarity only (+0.3V ... +3V)), unit [V]		
p0764[0...1]	CU analog inputs dead zone / CU AI dead zone		
	Access level: 2	Calculated: -	Data type: FloatingPoint32
	Can be changed: U, T	Scaling: -	Dyn. index: -
	Unit group: -	Unit selection: -	Func. diagram: 9566, 9568, 9576
	Min	Max	Factory setting
	0.000	20.000	[0] 0.300 [1] 0.300
Description:	Determines the width of the dead zone at the analog input. Analog input type unipolar (e.g. 0 ... +10 V): The dead zone starts with the characteristic value x1/y1 (p0757/p0758).		
Index:	[0] = Motor speed potentiometer 1 [1] = Motor speed potentiometer 2		
Notice:	For index [2]: The dead zone is automatically set and cannot be changed by the user.		

p0795	CU digital inputs simulation mode / CU DI simulation			
	Access level: 2	Calculated: -	Data type: Unsigned32	
	Can be changed: U, T	Scaling: -	Dyn. index: -	
	Unit group: -	Unit selection: -	Func. diagram: 2020, 2030, 2031, 2100, 2119, 2120, 2130, 2131, 2132, 2133	
	Min	Max	Factory setting	
	-	-	0000 0000 0000 0000 0000 0000 0000 0000 0000 bin	
Description:	Sets the simulation mode for digital inputs.			
Bit field:	Bit	Signal name	1 signal	0 signal
	00	DI 0 (X500.4)	Simulation	Terminal eval
	01	DI 1 (X500.3)	Simulation	Terminal eval
	02	DI 2 (X501.4)	Simulation	Terminal eval
	03	DI 3 (X501.3)	Simulation	Terminal eval
	24	DI/DO 24 (X502.4)	Simulation	Terminal control
	25	DI/DO 25 (X502.3)	Simulation	Terminal control
Dependency:	Refer to: p0796			
Note:	This parameter is not saved when data is backed-up (p0971, p0977). DI: Digital Input DI/DO: Bidirectional Digital Input/Output			

p0796	CU digital inputs simulation mode setpoint / CU DI simul setp			
	Access level: 2	Calculated: -	Data type: Unsigned32	
	Can be changed: U, T	Scaling: -	Dyn. index: -	
	Unit group: -	Unit selection: -	Func. diagram: 2020, 2030, 2031, 2100, 2119, 2120, 2130, 2131, 2132, 2133	
	Min	Max	Factory setting	
	-	-	0000 0000 0000 0000 0000 0000 0000 0000 0000 bin	
Description:	Sets the setpoint for the input signals in the digital input simulation mode.			
Bit field:	Bit	Signal name	1 signal	0 signal
	00	DI 0 (X500.4)	High	Low
	01	DI 1 (X500.3)	High	Low
	02	DI 2 (X501.4)	High	Low
	03	DI 3 (X501.3)	High	Low
	24	DI/DO 24 (X502.4)	High	Low
	25	DI/DO 25 (X502.3)	High	Low
Dependency:	The simulation of a digital input is selected using p0795. Refer to: p0795			
Note:	This parameter is not saved when data is backed-up (p0971, p0977). DI: Digital Input DI/DO: Bidirectional Digital Input/Output			

p0797[0...1]	CU analog inputs simulation mode / CU AI sim_mode			
	Access level: 3	Calculated: -	Data type: Integer16	
	Can be changed: U, T	Scaling: -	Dyn. index: -	
	Unit group: -	Unit selection: -	Func. diagram: -	
	Min	Max	Factory setting	
	0	1	0	
Description:	Sets the simulation mode for the analog inputs.			
Value:	0: Terminal evaluation for analog input x 1: Simulation for analog input x			
Index:	[0] = Motor speed potentiometer 1 [1] = Motor speed potentiometer 2			

2 Parameters

2.2 List of parameters

Dependency: The setpoint for the input voltage is specified via p0798.

Refer to: p0798

Note: This parameter is not saved when data is backed up (p0971).

p0798[0...1]

CU analog inputs simulation mode setpoint / CU AI sim setp

Access level: 3	Calculated: -	Data type: FloatingPoint32
Can be changed: U, T	Scaling: -	Dyn. index: -
Unit group: -	Unit selection: -	Func. diagram: -
Min -50.000	Max 2000.000	Factory setting 0.000

Description: Sets the setpoint for the input value in the simulation mode of the analog inputs.

Index: [0] = Motor speed potentiometer 1

[1] = Motor speed potentiometer 2

Dependency: The simulation of an analog input is selected using p0797.

If AI x is parameterized as a voltage input (p0756), the setpoint is a voltage in V.

Refer to: p0797

Note: This parameter is not saved when data is backed up (p0971).

p0802

Data transfer: memory card as source/target / mem_card src/targ

Access level: 3	Calculated: -	Data type: Integer16
Can be changed: T	Scaling: -	Dyn. index: -
Unit group: -	Unit selection: -	Func. diagram: -
Min 0	Max 100	Factory setting 0

Description: Sets the number for data transfer of a parameter backup from/to memory card.

Transfer from memory card to device memory (p0804 = 1):

- sets the source of parameter backup (e.g. p0802 = 48 --> PS048xxx.ACX is the source).

Transfer from non-volatile device memory to memory card (p0804 = 2):

- sets the target of parameter backup (e.g. p0802 = 23 --> PS023xxx.ACX is the target).

Dependency: Refer to: p0803, p0804

Note: The volatile device memory is not influenced by data transfer.

p0803

Data transfer: device memory as source/target / Dev_mem src/targ

Access level: 3	Calculated: -	Data type: Integer16
Can be changed: T	Scaling: -	Dyn. index: -
Unit group: -	Unit selection: -	Func. diagram: -
Min 0	Max 30	Factory setting 0

Description: Sets the number for data transfer of a parameter backup from/to the non-volatile device memory.

Transfer from memory card to device memory (p0804 = 1):

- sets the target of the parameter backup (e.g. p0803 = 10 --> PS010xxx.ACX is the target).

Transfer from non-volatile device memory to memory card (p0804 = 2):

- sets the source of the parameter backup (e.g. p0803 = 11 --> PS011xxx.ACX is the source).

Value:

0:	Source/target standard
10:	Source/target with setting 10
11:	Source/target with setting 11
12:	Source/target with setting 12
30:	Source/target with setting 30

Dependency: Refer to: p0802, p0804

Note: The volatile device memory is not influenced by data transfer.

p0804		Data transfer start / Data transf start	
G115D I/O	Access level: 3	Calculated: -	Data type: Integer16
G115D ASI	Can be changed: T	Scaling: -	Dyn. index: -
	Unit group: -	Unit selection: -	Func. diagram: -
	Min	Max	Factory setting
	0	1100	0
Description:	<p>Sets the transfer direction and start of data transfer between the memory card and non-volatile device memory.</p> <p>Example 1:</p> <p>The parameter backup is to be transferred from the non-volatile device memory to the memory card with setting 0. The parameter backup is to be stored on the memory card with setting 22.</p> <p>p0802 = 22 (parameter backup stored on memory card as target with setting 22)</p> <p>p0803 = 0 (parameter backup stored in device memory as source with setting 0)</p> <p>p0804 = 2 (start data transfer from device memory to memory card)</p> <p>--> PS000xxx.ACX is transferred from device memory to memory card and stored as PS022xxx.ACX.</p> <p>--> the parameter backup PS022xxx.ACX on the memory card can be used for data backup.</p> <p>Example 2:</p> <p>The parameter backup is to be transferred from the memory card to the non-volatile device memory with setting 22. The parameter backup is to be stored in the device memory as setting 10.</p> <p>p0802 = 22 (parameter backup stored on memory card as source with setting 22)</p> <p>p0803 = 10 (define parameter backup with setting 10 as target in the device memory)</p> <p>p0804 = 1 (start data transfer from memory card to device memory)</p> <p>--> PS022xxx.ACX is transferred from memory card to device memory and stored as PS010xxx.ACX.</p> <p>--> this parameter backup can be loaded to the volatile device memory using p0010 = 30 and p0970 = 10.</p> <p>--> to permanently save in the device memory and also on the memory card, this parameter backup should be saved using p0971 = 1.</p> <p>Example 3 (only supported for PROFIBUS/PROFINET):</p> <p>The PROFIBUS or PROFINET device master data (GSD) should be transferred from the device memory to the memory card.</p> <p>p0802 = (not relevant)</p> <p>p0803 = (not relevant)</p> <p>p0804 = 12 (start transferring the GSD files to the memory card)</p> <p>--> The GSD files are transferred from the device memory to the memory card and stored in the /SIEMENS/SINAMICS/DATA/CFG directory.</p>		
Value:	<p>0: Inactive</p> <p>1: Memory card to device memory</p> <p>2: Device memory to memory card</p> <p>1001: File on memory card cannot be opened</p> <p>1002: File in device memory cannot be opened</p> <p>1003: Memory card not found</p> <p>1100: File cannot be transferred</p>		
Recommendation:	<p>When switching off/switching on, a possibly valid parameter backup is loaded to the memory card with setting 0. Therefore, we do not recommend parameter backup with setting 0 (p0803 = 0) in the non-volatile device memory.</p>		
Dependency:	<p>Refer to: p0802, p0803</p>		
Notice:	<p>The memory card must not be removed while data is being transferred.</p>		

Note: If a parameter backup with setting 0 is detected on the memory card when the Control Unit is switched on (PS000xxx.ACX), this is transferred automatically to the device memory.
 When the memory card is inserted, a parameter backup with setting 0 (PS000xxx.ACX) is automatically written to the memory card when the parameters are saved in a non-volatile memory (e.g. by means of "Copy RAM to ROM").
 Once the data has been successfully transferred, this parameter is automatically reset to 0. If an error occurs, the parameter is set to a value > 1000. Possible fault causes:
 p0804 = 1001:
 The parameter backup set in p0802 as the source on the memory card does not exist or there is not sufficient memory space available on the memory card.
 p0804 = 1002:
 The parameter backup set in p0803 as the source in the device memory does not exist or there is not sufficient memory space available in the device memory.
 p0804 = 1003:
 No memory card has been inserted.
 p0804 = 1100:
 It is not possible to transfer at least one file.

p0804	Data transfer start / Data transf start		
G115D PN	Access level: 3	Calculated: -	Data type: Integer16
	Can be changed: T	Scaling: -	Dyn. index: -
	Unit group: -	Unit selection: -	Func. diagram: -
	Min	Max	Factory setting
	0	1100	0

Description: Sets the transfer direction and start of data transfer between the memory card and non-volatile device memory.
 Example 1:
 The parameter backup is to be transferred from the non-volatile device memory to the memory card with setting 0.
 The parameter backup is to be stored on the memory card with setting 22.
 p0802 = 22 (parameter backup stored on memory card as target with setting 22)
 p0803 = 0 (parameter backup stored in device memory as source with setting 0)
 p0804 = 2 (start data transfer from device memory to memory card)
 --> PS000xxx.ACX is transferred from device memory to memory card and stored as PS022xxx.ACX.
 --> the parameter backup PS022xxx.ACX on the memory card can be used for data backup.
 Example 2:
 The parameter backup is to be transferred from the memory card to the non-volatile device memory with setting 22.
 The parameter backup is to be stored in the device memory as setting 10.
 p0802 = 22 (parameter backup stored on memory card as source with setting 22)
 p0803 = 10 (define parameter backup with setting 10 as target in the device memory)
 p0804 = 1 (start data transfer from memory card to device memory)
 --> PS022xxx.ACX is transferred from memory card to device memory and stored as PS010xxx.ACX.
 --> this parameter backup can be loaded to the volatile device memory using p0010 = 30 and p0970 = 10.
 --> to permanently save in the device memory and also on the memory card, this parameter backup should be saved using p0971 = 1.
 Example 3 (only supported for PROFIBUS/PROFINET):
 The PROFIBUS or PROFINET device master data (GSD) should be transferred from the device memory to the memory card.
 p0802 = (not relevant)
 p0803 = (not relevant)
 p0804 = 12 (start transferring the GSD files to the memory card)
 --> The GSD files are transferred from the device memory to the memory card and stored in the /SIEMENS/SINAMICS/DATA/CFG directory.

Value:	0: Inactive 1: Memory card to device memory 2: Device memory to memory card 12: Device memory (GSD files) to memory card 1001: File on memory card cannot be opened 1002: File in device memory cannot be opened 1003: Memory card not found 1100: File cannot be transferred
Recommendation:	When switching off/switching on, a possibly valid parameter backup is loaded to the memory card with setting 0. Therefore, we do not recommend parameter backup with setting 0 (p0803 = 0) in the non-volatile device memory.
Dependency:	Refer to: p0802, p0803
Notice:	The memory card must not be removed while data is being transferred.
Note:	If a parameter backup with setting 0 is detected on the memory card when the Control Unit is switched on (PS000xxx.ACX), this is transferred automatically to the device memory. When the memory card is inserted, a parameter backup with setting 0 (PS000xxx.ACX) is automatically written to the memory card when the parameters are saved in a non-volatile memory (e.g. by means of "Copy RAM to ROM"). Once the data has been successfully transferred, this parameter is automatically reset to 0. If an error occurs, the parameter is set to a value > 1000. Possible fault causes: p0804 = 1001: The parameter backup set in p0802 as the source on the memory card does not exist or there is not sufficient memory space available on the memory card. p0804 = 1002: The parameter backup set in p0803 as the source in the device memory does not exist or there is not sufficient memory space available in the device memory. p0804 = 1003: No memory card has been inserted. p0804 = 1100: It is not possible to transfer at least one file.

p0806	BI: Inhibit master control / PcCtrl inhibit			
	Access level: 3	Calculated: -	Data type: U32 / Binary	
	Can be changed: T	Scaling: -	Dyn. index: -	
	Unit group: -	Unit selection: -	Func. diagram: -	
	Min	Max	Factory setting	
	-	-	0	
Description:	Sets the signal source to block the master control.			
Dependency:	Refer to: r0807			
Note:	The commissioning software (drive control panel) uses the master control, for example.			

r0807.0	BO: Master control active / PcCtrl active				
	Access level: 3	Calculated: -	Data type: Unsigned8		
	Can be changed: -	Scaling: -	Dyn. index: -		
	Unit group: -	Unit selection: -	Func. diagram: -		
	Min	Max	Factory setting		
	-	-	-		
Description:	Displays what has the master control. The drive can be controlled via the BICO interconnection or from external (e.g. the commissioning software).				
Bit field:	Bit	Signal name	1 signal	0 signal	FP
	00	Master control active	Yes	No	3030, 6031
Dependency:	Refer to: p0806				
Notice:	The master control only influences control word 1 and speed setpoint 1. Other control word/setpoints can be transferred from another automation device.				
Note:	Bit 0 = 0: BICO interconnection active Bit 0 = 1: Master control for PC/AOP The commissioning software (drive control panel) uses the master control, for example.				

p0809[0...2]	Copy Command Data Set CDS / Copy CDS		
	Access level: 2	Calculated: -	Data type: Unsigned8
	Can be changed: T	Scaling: -	Dyn. index: -
	Unit group: -	Unit selection: -	Func. diagram: 8560
	Min	Max	Factory setting
	0	3	0
Description:	Copies one Command Data Set (CDS) into another.		
Index:	[0] = Source Command Data Set [1] = Target Command Data Set [2] = Start copying procedure		
Dependency:	Refer to: r3996		
Notice:	When the command data sets are copied, short-term communication interruptions may occur.		
Note:	When copying a command data set (CDS), the values in p0700, p1000 and p1500 are not accepted. As a consequence, the associated macros are not executed and inconsistencies are avoided. Procedure: 1. In Index 0, enter which command data set should be copied. 2. In index 1, enter the command data set that is to be copied into. 3. Start copying: set index 2 from 0 to 1. p0809[2] is automatically set to 0 when copying is completed.		
p0810	BI: Command data set selection CDS bit 0 / CDS select., bit 0		
G115D ASI	Access level: 2	Calculated: -	Data type: U32 / Binary
	Can be changed: T	Scaling: -	Dyn. index: -
	Unit group: -	Unit selection: -	Func. diagram: 8560
	Min	Max	Factory setting
	-	-	0
Description:	Sets the signal source to select the Command Data Set bit 0 (CDS bit 0).		
Dependency:	Refer to: r0050, p0811, r0836		
Notice:	The parameter may be protected as a result of p0922 or p2079 and cannot be changed.		
Note:	The Command Data Set selected using the binector inputs is displayed in r0836. The currently effective command data set is displayed in r0050. A Command Data Set can be copied using p0809.		
p0810	BI: Command data set selection CDS bit 0 / CDS select., bit 0		
G115D I/O	Access level: 2	Calculated: -	Data type: U32 / Binary
	Can be changed: T	Scaling: -	Dyn. index: -
	Unit group: -	Unit selection: -	Func. diagram: 8560
	Min	Max	Factory setting
	-	-	722.3
Description:	Sets the signal source to select the Command Data Set bit 0 (CDS bit 0).		
Dependency:	Refer to: r0050, p0811, r0836		
Notice:	The parameter may be protected as a result of p0922 or p2079 and cannot be changed.		
Note:	The Command Data Set selected using the binector inputs is displayed in r0836. The currently effective command data set is displayed in r0050. A Command Data Set can be copied using p0809.		
p0810	BI: Command data set selection CDS bit 0 / CDS select., bit 0		
G115D PN	Access level: 2	Calculated: -	Data type: U32 / Binary
	Can be changed: T	Scaling: -	Dyn. index: -
	Unit group: -	Unit selection: -	Func. diagram: 8560
	Min	Max	Factory setting
	-	-	2090.15
Description:	Sets the signal source to select the Command Data Set bit 0 (CDS bit 0).		

Dependency: Refer to: r0050, p0811, r0836
Notice: The parameter may be protected as a result of p0922 or p2079 and cannot be changed.
Note: The Command Data Set selected using the binector inputs is displayed in r0836.
The currently effective command data set is displayed in r0050.
A Command Data Set can be copied using p0809.

p0811 **BI: Command data set selection CDS bit 1 / CDS select., bit 1**

Access level: 2	Calculated: -	Data type: U32 / Binary
Can be changed: T	Scaling: -	Dyn. index: -
Unit group: -	Unit selection: -	Func. diagram: 8560
Min	Max	Factory setting
-	-	0

Description: Sets the signal source to select the Command Data Set bit 1 (CDS bit 1).
Dependency: Refer to: r0050, p0810, r0836
Note: The Command Data Set selected using the binector inputs is displayed in r0836.
The currently effective command data set is displayed in r0050.
A Command Data Set can be copied using p0809.

p0819[0...2] **Copy Drive Data Set DDS / Copy DDS**

Access level: 2	Calculated: -	Data type: Unsigned8
Can be changed: C(15)	Scaling: -	Dyn. index: -
Unit group: -	Unit selection: -	Func. diagram: 8565
Min	Max	Factory setting
0	3	0

Description: Copies one Drive Data Set (DDS) into another.
Index: [0] = Source Drive Data Set
[1] = Target Drive Data Set
[2] = Start copying procedure
Dependency: Refer to: r3996
Notice: When the drive data sets are copied, short-term communication interruptions may occur.
Note: Procedure:
1. In Index 0, enter which drive data set is to be copied.
2. In index 1, enter the drive data set data that is to be copied into.
3. Start copying: set index 2 from 0 to 1.
p0819[2] is automatically set to 0 when copying is completed.

p0820[0...n] **BI: Drive Data Set selection DDS bit 0 / DDS select., bit 0**

Access level: 3	Calculated: -	Data type: U32 / Binary
Can be changed: T	Scaling: -	Dyn. index: CDS, p0170
Unit group: -	Unit selection: -	Func. diagram: 8565
Min	Max	Factory setting
-	-	0

Description: Sets the signal source to select the Drive Data Set, bit 0 (DDS, bit 0).
Dependency: Refer to: r0051, p0826, r0837
Notice: The parameter may be protected as a result of p0922 or p2079 and cannot be changed.

p0821[0...n] **BI: Drive Data Set selection DDS bit 1 / DDS select., bit 1**

Access level: 3	Calculated: -	Data type: U32 / Binary
Can be changed: T	Scaling: -	Dyn. index: CDS, p0170
Unit group: -	Unit selection: -	Func. diagram: 8565, 8570
Min	Max	Factory setting
-	-	0

Description: Sets the signal source to select the Drive Data Set, bit 1 (DDS, bit 1).
Dependency: Refer to: r0051, r0837

Notice: The parameter may be protected as a result of p0922 or p2079 and cannot be changed.

p0826[0...n]	Motor changeover motor number / Mot_chng mot No.		
	Access level: 3	Calculated: -	Data type: Unsigned16
	Can be changed: T	Scaling: -	Dyn. index: DDS, p0180
	Unit group: -	Unit selection: -	Func. diagram: -
	Min	Max	Factory setting
	0	3	0
Description:	Sets the freely assignable motor number for the drive data set changeover. If the same motor is driven by different drive data sets, the same motor number must also be entered in these data sets. If the motor is also switched with the drive data set, different motor numbers must be used. In this case, the data set can only be switched when the pulse inhibit is set.		
Note:	If the motor numbers are identical, the same thermal motor model is used for calculation after data set changeover. If different motor numbers are used, different models are also used for calculating (the inactive motor cools down in each case). For the same motor number, the correction values of the Rs, Lh or kT adaptation are applied for the data set changeover (refer to r1782, r1787, r1797).		

r0835.2...8	CO/BO: Data set changeover status word / DDS_ZSW				
	Access level: 2	Calculated: -	Data type: Unsigned16		
	Can be changed: -	Scaling: -	Dyn. index: -		
	Unit group: -	Unit selection: -	Func. diagram: 8575		
	Min	Max	Factory setting		
	-	-	-		
Description:	Displays the status word for the drive data set changeover.				
Bit field:	Bit	Signal name	1 signal	0 signal	FP
	02	Internal parameter calculation active	Yes	No	-
	04	Armature short circuit active	Yes	No	-
	05	Identification running	Yes	No	-
	06	Friction characteristic plot running	Yes	No	-
	07	Rotating measurement running	Yes	No	-
	08	Motor data identification running	Yes	No	-
Note:	For bit 02: A data set changeover is delayed by the time required for the internal parameter calculation. For bit 04: A data set changeover is only carried out when the armature short circuit is not activated. For bit 05: A data set changeover is only carried out when pole position identification is not running. For bit 07: A data set changeover is only carried out when rotating measurement is not running. For bit 08: A data set changeover is only carried out when motor data identification is not running.				

r0836.0...1	CO/BO: Command Data Set CDS selected / CDS selected				
	Access level: 3	Calculated: -	Data type: Unsigned8		
	Can be changed: -	Scaling: -	Dyn. index: -		
	Unit group: -	Unit selection: -	Func. diagram: 8560		
	Min	Max	Factory setting		
	-	-	-		
Description:	Displays the command data set (CDS) selected via the binector input.				
Bit field:	Bit	Signal name	1 signal	0 signal	FP
	00	CDS selection bit 0	ON	OFF	-
	01	CDS selection bit 1	ON	OFF	-
Dependency:	Refer to: r0050, p0810, p0811				

Note: Command data sets are selected via binector input p0810 and following.
The currently effective command data set is displayed in r0050.

r0837.0...1**CO/BO: Drive Data Set DDS selected / DDS selected**

Access level: 3	Calculated: -	Data type: Unsigned8
Can be changed: -	Scaling: -	Dyn. index: -
Unit group: -	Unit selection: -	Func. diagram: 8565
Min	Max	Factory setting
-	-	-

Description: Displays the drive data set (DDS) selected via the binector input.

Bit field:	Bit	Signal name	1 signal	0 signal	FP
	00	DDS selection bit 0	ON	OFF	-
	01	DDS selection bit 1	ON	OFF	-

Dependency: Refer to: r0051, p0820, p0821

Note: Drive data sets are selected via binector input p0820 and following.
The currently effective drive data set is displayed in r0051.
If there is only one data set, then a value of 0 is displayed in this parameter and not the selection via binector inputs.

p0840[0...n]**BI: ON / OFF (OFF1) / ON / OFF (OFF1)**

G115D I/O	Access level: 3	Calculated: -	Data type: U32 / Binary
	Can be changed: T	Scaling: -	Dyn. index: CDS, p0170
	Unit group: -	Unit selection: -	Func. diagram: 2501, 2512
	Min	Max	Factory setting
	-	-	[0] 3333.0
			[1] 3333.0
			[2] 0
			[3] 0

Description: Sets the signal source for the command "ON/OFF (OFF1)".

For the PROFIdrive profile, this command corresponds to control word 1 bit 0 (STW1.0).

Recommendation: When the setting for this binector input is changed, the motor can only be switched on by means of an appropriate signal change of the source.

Dependency: Refer to: p1055, p1056

Caution: When "master control from PC" is activated, this binector input is ineffective.



Notice: For binector input p0840 = 0 signal, the motor can be moved, jogging using binector input p1055 or p1056.

The command "ON/OFF (OFF1)" can be issued using binector input p0840 or p1055/p1056.

For binector input p0840 = 0 signal, the switching on inhibited is acknowledged.

Only the signal source that originally switched on can also switch off again.

The parameter may be protected as a result of p0922 or p2079 and cannot be changed.

Note: For drives with closed-loop speed control (p1300 = 20), the following applies:

- BI: p0840 = 0 signal: OFF1 (braking with the ramp-function generator, then pulse cancellation and switching on inhibited)

For drives with closed-loop torque control (p1300 = 22), the following applies:

- BI: p0840 = 0 signal: immediate pulse cancellation

For drives with closed-loop torque control (activated using p1501), the following applies:

- BI: p0840 = 0 signal: No dedicated braking response, but pulse cancellation when standstill is detected (p1226, p1227)

For drives with closed-loop speed/torque control, the following applies:

- BI: p0840 = 0/1 signal: ON (pulses can be enabled)

p0840[0...n]	BI: ON / OFF (OFF1) / ON / OFF (OFF1)		
G115D PN	Access level: 3	Calculated: -	Data type: U32 / Binary
G115D ASI	Can be changed: T	Scaling: -	Dyn. index: CDS, p0170
	Unit group: -	Unit selection: -	Func. diagram: 2501, 2512
	Min	Max	Factory setting
	-	-	[0] 2090.0
			[1] 0
			[2] 0
			[3] 0
Description:	Sets the signal source for the command "ON/OFF (OFF1)". For the PROFIdrive profile, this command corresponds to control word 1 bit 0 (STW1.0).		
Recommendation:	When the setting for this binector input is changed, the motor can only be switched on by means of an appropriate signal change of the source.		
Dependency:	Refer to: p1055, p1056		
Caution:	When "master control from PC" is activated, this binector input is ineffective.		
			
Notice:	For binector input p0840 = 0 signal, the motor can be moved, jogging using binector input p1055 or p1056. The command "ON/OFF (OFF1)" can be issued using binector input p0840 or p1055/p1056. For binector input p0840 = 0 signal, the switching on inhibited is acknowledged. Only the signal source that originally switched on can also switch off again. The parameter may be protected as a result of p0922 or p2079 and cannot be changed.		
Note:	For drives with closed-loop speed control (p1300 = 20), the following applies: - BI: p0840 = 0 signal: OFF1 (braking with the ramp-function generator, then pulse cancellation and switching on inhibited) For drives with closed-loop torque control (p1300 = 22), the following applies: - BI: p0840 = 0 signal: immediate pulse cancellation For drives with closed-loop torque control (activated using p1501), the following applies: - BI: p0840 = 0 signal: No dedicated braking response, but pulse cancellation when standstill is detected (p1226, p1227) For drives with closed-loop speed/torque control, the following applies: - BI: p0840 = 0/1 signal: ON (pulses can be enabled)		

p0844[0...n]	BI: No coast-down / coast-down (OFF2) signal source 1 / OFF2 S_s 1		
G115D ASI	Access level: 3	Calculated: -	Data type: U32 / Binary
	Can be changed: T	Scaling: -	Dyn. index: CDS, p0170
	Unit group: -	Unit selection: -	Func. diagram: 2501, 8720, 8820, 8920
	Min	Max	Factory setting
	-	-	[0] 2090.1
			[1] 1
			[2] 1
			[3] 1
Description:	Sets the first signal source for the command "No coast down/coast down (OFF2)". The following signals are AND'ed: - BI: p0844 "No coast-down / coast-down (OFF2) signal source 1" - BI: p0845 "No coast-down / coast-down (OFF2) signal source 2" For the PROFIdrive profile, the result of the AND logic operation corresponds to control word 1 bit 1 (STW1.1). BI: p0844 = 0 signal or BI: p0845 = 0 signal - OFF2 (immediate pulse cancellation and switching on inhibited) BI: p0844 = 1 signal and BI: p0845 = 1 signal - no OFF2 (enable is possible)		
Caution:	When "master control from PC" is activated, this binector input is ineffective.		
			

Notice: The parameter may be protected as a result of p0922 or p2079 and cannot be changed.

p0844[0...n]	BI: No coast-down / coast-down (OFF2) signal source 1 / OFF2 S_s 1		
G115D I/O	Access level: 3	Calculated: -	Data type: U32 / Binary
	Can be changed: T	Scaling: -	Dyn. index: CDS, p0170
	Unit group: -	Unit selection: -	Func. diagram: 2501, 8720, 8820, 8920
	Min	Max	Factory setting
	-	-	1

Description: Sets the first signal source for the command "No coast down/coast down (OFF2)".
The following signals are AND'ed:
- BI: p0844 "No coast-down / coast-down (OFF2) signal source 1"
- BI: p0845 "No coast-down / coast-down (OFF2) signal source 2"
For the PROFIdrive profile, the result of the AND logic operation corresponds to control word 1 bit 1 (STW1.1).
BI: p0844 = 0 signal or BI: p0845 = 0 signal
- OFF2 (immediate pulse cancellation and switching on inhibited)
BI: p0844 = 1 signal and BI: p0845 = 1 signal
- no OFF2 (enable is possible)

Caution: When "master control from PC" is activated, this binector input is ineffective.



Notice: The parameter may be protected as a result of p0922 or p2079 and cannot be changed.

p0844[0...n]	BI: No coast-down / coast-down (OFF2) signal source 1 / OFF2 S_s 1		
G115D PN	Access level: 3	Calculated: -	Data type: U32 / Binary
	Can be changed: T	Scaling: -	Dyn. index: CDS, p0170
	Unit group: -	Unit selection: -	Func. diagram: 2501, 8720, 8820, 8920
	Min	Max	Factory setting
	-	-	[0] 2090.1
			[1] 1
			[2] 2090.1
			[3] 2090.1

Description: Sets the first signal source for the command "No coast down/coast down (OFF2)".
The following signals are AND'ed:
- BI: p0844 "No coast-down / coast-down (OFF2) signal source 1"
- BI: p0845 "No coast-down / coast-down (OFF2) signal source 2"
For the PROFIdrive profile, the result of the AND logic operation corresponds to control word 1 bit 1 (STW1.1).
BI: p0844 = 0 signal or BI: p0845 = 0 signal
- OFF2 (immediate pulse cancellation and switching on inhibited)
BI: p0844 = 1 signal and BI: p0845 = 1 signal
- no OFF2 (enable is possible)

Caution: When "master control from PC" is activated, this binector input is ineffective.



Notice: The parameter may be protected as a result of p0922 or p2079 and cannot be changed.

p0845[0...n]	BI: No coast-down / coast-down (OFF2) signal source 2 / OFF2 S_s 2		
	Access level: 3	Calculated: -	Data type: U32 / Binary
	Can be changed: T	Scaling: -	Dyn. index: CDS, p0170
	Unit group: -	Unit selection: -	Func. diagram: 2501, 8720, 8820, 8920
	Min	Max	Factory setting
	-	-	1
Description:	Sets the second signal source for the command "No coast down/coast down (OFF2)". The following signals are AND'ed: - BI: p0844 "No coast-down / coast-down (OFF2) signal source 1" - BI: p0845 "No coast-down / coast-down (OFF2) signal source 2" For the PROFIdrive profile, the result of the AND logic operation corresponds to control word 1 bit 1 (STW1.1). BI: p0844 = 0 signal or BI: p0845 = 0 signal - OFF2 (immediate pulse cancellation and switching on inhibited) BI: p0844 = 1 signal and BI: p0845 = 1 signal - no OFF2 (enable is possible)		
Caution:	When "master control from PC" is activated, this binector input is effective.		



p0848[0...n]	BI: No Quick Stop / Quick Stop (OFF3) signal source 1 / OFF3 S_s 1		
G115D I/O	Access level: 3	Calculated: -	Data type: U32 / Binary
G115D ASI	Can be changed: T	Scaling: -	Dyn. index: CDS, p0170
	Unit group: -	Unit selection: -	Func. diagram: 2501
	Min	Max	Factory setting
	-	-	1
Description:	Sets the first signal source for the command "No quick stop/quick stop (OFF3)". The following signals are AND'ed: - BI: p0848 "No quick stop / quick stop (OFF3) signal source 1" - BI: p0849 "No quick stop / quick stop (OFF3) signal source 2" For the PROFIdrive profile, the result of the AND logic operation corresponds to control word 1 bit 2 (STW1.2). BI: p0848 = 0 signal or BI: p0849 = 0 signal - OFF3 (braking along the OFF3 ramp (p1135), then pulse cancellation and switching on inhibited) BI: p0848 = 1 signal and BI: p0849 = 1 signal - no OFF3 (enable is possible)		
Caution:	When "master control from PC" is activated, this binector input is ineffective.		



Notice:	The parameter may be protected as a result of p0922 or p2079 and cannot be changed.		
Note:	For drives with closed-loop torque control (activated using p1501), the following applies: BI: p0848 = 0 signal: - no dedicated braking response, but pulse cancellation when standstill is detected (p1226, p1227).		

p0848[0...n]	BI: No Quick Stop / Quick Stop (OFF3) signal source 1 / OFF3 S_s 1		
G115D PN	Access level: 3	Calculated: -	Data type: U32 / Binary
	Can be changed: T	Scaling: -	Dyn. index: CDS, p0170
	Unit group: -	Unit selection: -	Func. diagram: 2501
	Min	Max	Factory setting
	-	-	[0] 2090.2
			[1] 1
			[2] 2090.2
			[3] 2090.2

Description: Sets the first signal source for the command "No quick stop/quick stop (OFF3)".
The following signals are AND'ed:
- BI: p0848 "No quick stop / quick stop (OFF3) signal source 1"
- BI: p0849 "No quick stop / quick stop (OFF3) signal source 2"
For the PROFIdrive profile, the result of the AND logic operation corresponds to control word 1 bit 2 (STW1.2).
BI: p0848 = 0 signal or BI: p0849 = 0 signal
- OFF3 (braking along the OFF3 ramp (p1135), then pulse cancellation and switching on inhibited)
BI: p0848 = 1 signal and BI: p0849 = 1 signal
- no OFF3 (enable is possible)

Caution: When "master control from PC" is activated, this binector input is ineffective.



Notice: The parameter may be protected as a result of p0922 or p2079 and cannot be changed.

Note: For drives with closed-loop torque control (activated using p1501), the following applies:

BI: p0848 = 0 signal:
- no dedicated braking response, but pulse cancellation when standstill is detected (p1226, p1227).

p0849[0...n]	BI: No Quick Stop / Quick Stop (OFF3) signal source 2 / OFF3 S_s 2		
	Access level: 3	Calculated: -	Data type: U32 / Binary
	Can be changed: T	Scaling: -	Dyn. index: CDS, p0170
	Unit group: -	Unit selection: -	Func. diagram: 2501
	Min	Max	Factory setting
	-	-	1

Description: Sets the second signal source for the command "No quick stop/quick stop (OFF3)".
The following signals are AND'ed:
- BI: p0848 "No quick stop / quick stop (OFF3) signal source 1"
- BI: p0849 "No quick stop / quick stop (OFF3) signal source 2"
For the PROFIdrive profile, the result of the AND logic operation corresponds to control word 1 bit 2 (STW1.2).
BI: p0848 = 0 signal or BI: p0849 = 0 signal
- OFF3 (braking along the OFF3 ramp (p1135), then pulse cancellation and switching on inhibited)
BI: p0848 = 1 signal and BI: p0849 = 1 signal
- no OFF3 (enable is possible)

Caution: When "master control from PC" is activated, this binector input is effective.



Note: For drives with closed-loop torque control (activated using p1501), the following applies:

BI: p0849 = 0 signal:
- no dedicated braking response, but pulse cancellation when standstill is detected (p1226, p1227).

p0852[0...n]		BI: Enable operation/inhibit operation / Enable operation	
G115D I/O	Access level: 3	Calculated: -	Data type: U32 / Binary
G115D ASI	Can be changed: T	Scaling: -	Dyn. index: CDS, p0170
	Unit group: -	Unit selection: -	Func. diagram: 2501
	Min	Max	Factory setting
	-	-	1
Description:	Sets the signal source for the command "enable operation/inhibit operation". For the PROFIdrive profile, this command corresponds to control word 1 bit 3 (STW1.3). BI: p0852 = 0 signal Inhibit operation (suppress pulses). BI: p0852 = 1 signal Enable operation (pulses can be enabled).		
Caution:	When "master control from PC" is activated, this binector input is ineffective.		
			
Notice:	The parameter may be protected as a result of p0922 or p2079 and cannot be changed.		

p0852[0...n]		BI: Enable operation/inhibit operation / Enable operation	
G115D PN	Access level: 3	Calculated: -	Data type: U32 / Binary
	Can be changed: T	Scaling: -	Dyn. index: CDS, p0170
	Unit group: -	Unit selection: -	Func. diagram: 2501
	Min	Max	Factory setting
	-	-	[0] 2090.3
			[1] 1
			[2] 2090.3
			[3] 2090.3
Description:	Sets the signal source for the command "enable operation/inhibit operation". For the PROFIdrive profile, this command corresponds to control word 1 bit 3 (STW1.3). BI: p0852 = 0 signal Inhibit operation (suppress pulses). BI: p0852 = 1 signal Enable operation (pulses can be enabled).		
Caution:	When "master control from PC" is activated, this binector input is ineffective.		
			
Notice:	The parameter may be protected as a result of p0922 or p2079 and cannot be changed.		

p0854[0...n]		BI: Control by PLC/no control by PLC / Master ctrl by PLC	
G115D I/O	Access level: 3	Calculated: -	Data type: U32 / Binary
G115D ASI	Can be changed: T	Scaling: -	Dyn. index: CDS, p0170
	Unit group: -	Unit selection: -	Func. diagram: 2501
	Min	Max	Factory setting
	-	-	1
Description:	Sets the signal source for the command "control by PLC/no control by PLC". For the PROFIdrive profile, this command corresponds to control word 1 bit 10 (STW1.10). BI: p0854 = 0 signal No control by PLC BI: p0854 = 1 signal Master control by PLC.		
Caution:	When "master control from PC" is activated, this binector input is ineffective.		
			
Notice:	The parameter may be protected as a result of p0922 or p2079 and cannot be changed.		

Note: This bit is used to initiate a response for the drives when the control fails (F07220). If there is no control available, then binector input p0854 should be set to 1.
If a control is available, then STW1.10 must be set to 1 (PZD1) so that the received data is updated. This applies regardless of the setting in p0854 and even in the case of free telegram configuration (p0922 = 999).

p0854[0...n]	BI: Control by PLC/no control by PLC / Master ctrl by PLC		
G115D PN	Access level: 3	Calculated: -	Data type: U32 / Binary
	Can be changed: T	Scaling: -	Dyn. index: CDS, p0170
	Unit group: -	Unit selection: -	Func. diagram: 2501
	Min	Max	Factory setting
	-	-	[0] 2090.10
			[1] 1
			[2] 2090.10
			[3] 2090.10

Description: Sets the signal source for the command "control by PLC/no control by PLC".
For the PROFIdrive profile, this command corresponds to control word 1 bit 10 (STW1.10).
BI: p0854 = 0 signal
No control by PLC
BI: p0854 = 1 signal
Master control by PLC.

Caution: When "master control from PC" is activated, this binector input is ineffective.



Notice: The parameter may be protected as a result of p0922 or p2079 and cannot be changed.

Note: This bit is used to initiate a response for the drives when the control fails (F07220). If there is no control available, then binector input p0854 should be set to 1.
If a control is available, then STW1.10 must be set to 1 (PZD1) so that the received data is updated. This applies regardless of the setting in p0854 and even in the case of free telegram configuration (p0922 = 999).

p0855[0...n]	BI: Unconditionally release holding brake / Uncond open brake		
	Access level: 3	Calculated: -	Data type: U32 / Binary
	Can be changed: T	Scaling: -	Dyn. index: CDS, p0170
	Unit group: -	Unit selection: -	Func. diagram: 2501, 2701
	Min	Max	Factory setting
	-	-	0

Description: Sets the signal source for the command "unconditionally open holding brake".

Dependency: Refer to: p0858

Notice: The parameter may be protected as a result of p0922 or p2079 and cannot be changed.

Note: The signal via BI: p0858 (unconditionally close holding brake) has a higher priority than via BI: p0855 (unconditionally open holding brake).

p0856[0...n]	BI: Enable speed controller / n_ctrl enable		
	Access level: 3	Calculated: -	Data type: U32 / Binary
	Can be changed: T	Scaling: -	Dyn. index: CDS, p0170
	Unit group: -	Unit selection: -	Func. diagram: 2501, 2701
	Min	Max	Factory setting
	-	-	1

Description: Sets the signal source for the command "enable speed controller" (r0898.12).

0 signal: Set the I component and speed controller output to zero.

1 signal: Enable speed controller.

Dependency: Refer to: r0898

Note: If "enable speed controller" is withdrawn, then an existing brake will be closed.

If "enable speed controller" is withdrawn, the pulses are not cancelled.

p0857	Power unit monitoring time / PU t_monit		
	Access level: 3	Calculated: -	Data type: FloatingPoint32
	Can be changed: T	Scaling: -	Dyn. index: -
	Unit group: -	Unit selection: -	Func. diagram: -
	Min	Max	Factory setting
	100.0 [ms]	60000.0 [ms]	10000.0 [ms]
Description:	Sets the monitoring time for the power unit. The monitoring time is started after an 0/1 edge of the ON/OFF1 command. If the power unit does not return a READY signal within the monitoring time, fault F07802 is output.		
Dependency:	Refer to: F07802, F30027		
Notice:	The maximum time to precharge the DC link is monitored in the power unit and cannot be changed. The maximum precharging duration depends on the power unit. The monitoring time for the precharging is started after the ON command (BI: p0840 = 0/1 signal). Fault F30027 is output when the maximum precharging duration is exceeded.		
Note:	The factory setting for p0857 depends on the power unit. The monitoring time for the ready signal of the power unit includes the time to precharge the DC link and, if relevant, the de-bounce time of the contactors. If an excessively low value is entered into p0857, then after enable, this results in the corresponding fault.		
p0858[0...n]	BI: Unconditionally close holding brake / Uncond close brake		
	Access level: 3	Calculated: -	Data type: U32 / Binary
	Can be changed: T	Scaling: -	Dyn. index: CDS, p0170
	Unit group: -	Unit selection: -	Func. diagram: 2501, 2701
	Min	Max	Factory setting
	-	-	0
Description:	Sets the signal source for the command "unconditionally close holding brake".		
Dependency:	Refer to: p0855		
Note:	The signal via BI: p0858 (unconditionally close holding brake) has a higher priority than via BI: p0855 (unconditionally open holding brake). For a 1 signal via BI: p0858, the command "unconditionally close the holding brake" is executed and internally a zero setpoint is entered.		
p0860	BI: Line contactor feedback signal / Line contact feedb		
	Access level: 3	Calculated: -	Data type: U32 / Binary
	Can be changed: T	Scaling: -	Dyn. index: -
	Unit group: -	Unit selection: -	Func. diagram: 2634
	Min	Max	Factory setting
	-	-	863.1
Description:	Sets the signal source for the feedback signal from the line contactor.		
Recommendation:	When the monitoring is activated (BI: p0860 not equal to r0863.1), then to control the line contactor, signal BO: r0863.1 of its own drive object should be used.		
Dependency:	Refer to: p0861, r0863 Refer to: F07300		
Notice:	The line contactor monitoring is deactivated if the control signal of the particular drive object is set as the signal source for the feedback signal of the line contactor (BI: p0860 = r0863.1).		
Note:	The state of the line contactor is monitored depending on signal BO: r0863.1. When the monitoring is activated (BI: p0860 not equal to r0863.1), fault F07300 is then also output if the contactor is closed before it is controlled using r0863.1.		

p0861	Line contactor monitoring time / LineContact t_mon				
	Access level: 3	Calculated: -	Data type: FloatingPoint32		
	Can be changed: T	Scaling: -	Dyn. index: -		
	Unit group: -	Unit selection: -	Func. diagram: 2634		
	Min	Max	Factory setting		
	0 [ms]	5000 [ms]	100 [ms]		
Description:	Sets the monitoring time of the line contactor. This time starts each time that the line contactor switches (r0863.1). If a feedback signal is not received from the line contactor within the time, a message is output.				
Dependency:	Refer to: p0860, r0863 Refer to: F07300				
Note:	The monitoring function is disabled for the factory setting of p0860.				
r0863.0...1	CO/BO: Drive coupling status word/control word / CoupleZSW/STW				
	Access level: 3	Calculated: -	Data type: Unsigned16		
	Can be changed: -	Scaling: -	Dyn. index: -		
	Unit group: -	Unit selection: -	Func. diagram: -		
	Min	Max	Factory setting		
	-	-	-		
Description:	Display and BICO output for the status word and control word of the drive coupling.				
Bit field:	Bit	Signal name	1 signal	0 signal	FP
	00	Closed-loop control operation	Yes	No	-
	01	Energize contactor	Yes	No	2634
Note:	For bit 01: Bit 1 is used to control an external line contactor.				
p0867	Power unit main contactor holding time after OFF1 / PU t_MC after OFF1				
	Access level: 3	Calculated: -	Data type: FloatingPoint32		
	Can be changed: T	Scaling: -	Dyn. index: -		
	Unit group: -	Unit selection: -	Func. diagram: -		
	Min	Max	Factory setting		
	0.0 [ms]	500.0 [ms]	50.0 [ms]		
Description:	Sets the main contactor holding time after OFF1				
Dependency:	Refer to: p0869				
Note:	After withdrawing the OFF1 enable (source of p0840), the main contactor is opened after the main contactor holding time has elapsed. For p0869 = 1 (keep main contactor closed for STO), after withdrawing STO, the switching on inhibited must be acknowledged via the source of p0840 = 0 (OFF1) – and before the main contactor holding time expires, should go back to 1, otherwise the main contactor will open. When operating a drive connected to SINUMERIK, which only closes the main contactor with the OFF1 command (blocksize, chassis), p0867 should be set as a minimum to 50 ms.				
p0869	Sequence control configuration / Seq_ctrl config				
	Access level: 3	Calculated: -	Data type: Unsigned16		
	Can be changed: T	Scaling: -	Dyn. index: -		
	Unit group: -	Unit selection: -	Func. diagram: -		
	Min	Max	Factory setting		
	-	-	0000 bin		
Description:	Sets the configuration for the sequence control.				
Bit field:	Bit	Signal name	1 signal	0 signal	FP
	00	Keep main contactor closed for STO	Yes	No	-
Dependency:	Refer to: p0867				

2 Parameters

2.2 List of parameters

Note: For bit 00:
After withdrawing the OFF1 enable (source of p0840), the main contactor is opened after the main contactor holding time has elapsed.
For p0869.0 = 1, after withdrawing STO, the switching on inhibited must be acknowledged via the source of p0840 = 0 (OFF1) – and before the main contactor holding time expires (p0867), should go back to 1, otherwise the main contactor will open.

p0870 **BI: Close main contactor / Close main cont**

Access level: 2	Calculated: -	Data type: U32 / Binary
Can be changed: T	Scaling: -	Dyn. index: -
Unit group: -	Unit selection: -	Func. diagram: -
Min	Max	Factory setting
-	-	0

Description: Sets the signal source to close the main contactor.
Note: The main contactor is also closed when the converter is switched on after issuing the necessary enable signals. A binector input p0870 = 1 signal prevents the main contactor from being opened when enable signals are withdrawn.

p0897 **BI: Parking axis selection / Parking axis sel**

Access level: 2	Calculated: -	Data type: U32 / Binary
Can be changed: T	Scaling: -	Dyn. index: -
Unit group: -	Unit selection: -	Func. diagram: -
Min	Max	Factory setting
-	-	0

Description: Sets the signal source to select the "parking axis" function.
Dependency: BI: p0897 = 0 signal
The function "parking axis" is not selected.
BI: p0897 = 1 signal
The function "parking axis" is selected.
Notice: The parameter may be protected as a result of p0922 or p2079 and cannot be changed.
Note: After it has been selected the "parking axis" function only becomes active when the pulses are cancelled.

r0898.0...14 **CO/BO: Control word sequence control / STW seq_ctrl**

Access level: 2	Calculated: -	Data type: Unsigned16
Can be changed: -	Scaling: -	Dyn. index: -
Unit group: -	Unit selection: -	Func. diagram: 2501
Min	Max	Factory setting
-	-	-

Description: Display and connector output for the control word of the sequence control.

Bit field:	Bit	Signal name	1 signal	0 signal	FP
	00	ON/OFF1	Yes	No	-
	01	OC / OFF2	Yes	No	-
	02	OC / OFF3	Yes	No	-
	03	Enable operation	Yes	No	-
	04	Enable ramp-function generator	Yes	No	-
	05	Continue ramp-function generator	Yes	No	-
	06	Enable speed setpoint	Yes	No	-
	07	Command open brake	Yes	No	-
	08	Jog 1	Yes	No	3001
	09	Jog 2	Yes	No	3001
	10	Master control by PLC	Yes	No	-
	12	Speed controller enable	Yes	No	-
	14	Command close brake	Yes	No	-

Note: OC: Operating condition

r0899.0...13		CO/BO: Status word sequence control / ZSW seq_ctrl			
	Access level: 2	Calculated: -	Data type: Unsigned16		
	Can be changed: -	Scaling: -	Dyn. index: -		
	Unit group: -	Unit selection: -	Func. diagram: 2503		
	Min	Max	Factory setting		
	-	-	-		
Description:	Display and BICO output for the status word of the sequence control.				
Bit field:	Bit	Signal name	1 signal	0 signal	FP
	00	Ready for switching on	Yes	No	-
	01	Ready	Yes	No	-
	02	Operation enabled	Yes	No	-
	03	Jog active	Yes	No	-
	04	No coasting active	OFF2 inactive	OFF2 active	-
	05	No Quick Stop active	OFF3 inactive	OFF3 active	-
	06	Switching on inhibited active	Yes	No	-
	07	Drive ready	Yes	No	-
	08	Controller enable	Yes	No	-
	09	Control request	Yes	No	-
	11	Pulses enabled	Yes	No	-
	12	Open holding brake	Yes	No	-
	13	Command close holding brake	Yes	No	-
Note:	For bits 00, 01, 02, 04, 05, 06, 09: For PROFIdrive, these signals are used for status word 1.				

p0922		PROFIdrive PZD telegram selection / PZD telegr_sel		
G115D PN	Access level: 1	Calculated: -	Data type: Unsigned16	
	Can be changed: C(1), T	Scaling: -	Dyn. index: -	
	Unit group: -	Unit selection: -	Func. diagram: 2401, 2420	
	Min	Max	Factory setting	
	1	999	999	
Description:	Sets the send and receive telegram.			
Value:	1: Standard telegram 1, PZD-2/2 3: Standard telegram 3, PZD-5/9 20: Standard telegram 20, PZD-2/6 350: SIEMENS telegram 350, PZD-4/4 352: SIEMENS telegram 352, PZD-6/6 353: SIEMENS telegram 353, PZD-2/2, PKW-4/4 354: SIEMENS telegram 354, PZD-6/6, PKW-4/4 999: Free telegram configuration with BICO			
Dependency:	Refer to: p2038 Refer to: F01505			
Note:	If a value is not equal to 999, a telegram is set and the automatically set interconnections in the telegram are inhibited. The inhibited interconnections can only be changed again after setting value 999.			

r0944		CO: Counter for fault buffer changes / Fault buff change		
	Access level: 3	Calculated: -	Data type: Unsigned16	
	Can be changed: -	Scaling: -	Dyn. index: -	
	Unit group: -	Unit selection: -	Func. diagram: 8060	
	Min	Max	Factory setting	
	-	-	-	
Description:	Display and connector output for the counter for changes of the fault buffer. This counter is incremented every time the fault buffer changes.			
Recommendation:	Used to check whether the fault buffer has been read out consistently.			
Dependency:	Refer to: r0945, r0947, r0948, r0949, r2109			

r0945[0...63]	Fault code / Fault code		
	Access level: 3	Calculated: -	Data type: Unsigned16
	Can be changed: -	Scaling: -	Dyn. index: -
	Unit group: -	Unit selection: -	Func. diagram: 8050, 8060
	Min	Max	Factory setting
	-	-	-
Description:	Displays the numbers of faults that have occurred.		
Dependency:	Refer to: r0947, r0948, r0949, r2109, r2130, r2133, r2136, r3120, r3122		
Notice:	The properties of the fault buffer should be taken from the corresponding product documentation.		
Note:	The buffer parameters are cyclically updated in the background (refer to status signal in r2139). Fault buffer structure (general principle): r0945[0], r0949[0], r0948[0], r2109[0] --> actual fault case, fault 1 ... r0945[7], r0949[7], r0948[7], r2109[7] --> actual fault case, fault 8 r0945[8], r0949[8], r0948[8], r2109[8] --> 1st acknowledged fault case, fault 1 ... r0945[15], r0949[15], r0948[15], r2109[15] --> 1st acknowledged fault case, fault 8 ... r0945[56], r0949[56], r0948[56], r2109[56] --> 7th acknowledged fault case, fault 1 ... r0945[63], r0949[63], r0948[63], r2109[63] --> 7th acknowledged fault case, fault 8		

r0946[0...65534]	Fault code list / Fault code list		
	Access level: 3	Calculated: -	Data type: Unsigned16
	Can be changed: -	Scaling: -	Dyn. index: -
	Unit group: -	Unit selection: -	Func. diagram: 8060
	Min	Max	Factory setting
	-	-	-
Description:	Lists the fault codes stored in the drive unit. The indices can only be accessed with a valid fault code.		
Dependency:	The parameter assigned to the fault code is entered in r0951 under the same index.		

r0947[0...63]	Fault number / Fault number		
	Access level: 2	Calculated: -	Data type: Unsigned16
	Can be changed: -	Scaling: -	Dyn. index: -
	Unit group: -	Unit selection: -	Func. diagram: 8050, 8060
	Min	Max	Factory setting
	-	-	-
Description:	This parameter is identical to r0945.		

r0948[0...63]	Fault time received in milliseconds / t_fault rcv ms		
	Access level: 3	Calculated: -	Data type: Unsigned32
	Can be changed: -	Scaling: -	Dyn. index: -
	Unit group: -	Unit selection: -	Func. diagram: 8050, 8060
	Min	Max	Factory setting
	- [ms]	- [ms]	- [ms]
Description:	Displays the system runtime in milliseconds when the fault occurred.		
Dependency:	Refer to: r0945, r0947, r0949, r2109, r2130, r2133, r2136		
Notice:	The time comprises r2130 (days) and r0948 (milliseconds).		
Note:	The buffer parameters are cyclically updated in the background (refer to status signal in r2139). The structure of the fault buffer and the assignment of the indices is shown in r0945. When the parameter is read via PROFIdrive, the TimeDifference data type applies.		

r0949[0...63]	Fault value / Fault value		
	Access level: 3	Calculated: -	Data type: Integer32
	Can be changed: -	Scaling: -	Dyn. index: -
	Unit group: -	Unit selection: -	Func. diagram: 8050, 8060
	Min	Max	Factory setting
	-	-	-
Description:	Displays additional information about the fault that occurred (as integer number).		
Dependency:	Refer to: r0945, r0947, r0948, r2109, r2130, r2133, r2136, r3120, r3122		
Note:	The buffer parameters are cyclically updated in the background (refer to status signal in r2139). The structure of the fault buffer and the assignment of the indices is shown in r0945.		
p0952	Fault cases counter / Fault cases qty		
	Access level: 3	Calculated: -	Data type: Unsigned16
	Can be changed: U, T	Scaling: -	Dyn. index: -
	Unit group: -	Unit selection: -	Func. diagram: 6700, 8060
	Min	Max	Factory setting
	0	65535	0
Description:	Number of fault situations that have occurred since the last reset.		
Dependency:	The fault buffer is deleted (cleared) by setting p0952 to 0. Refer to: r0945, r0947, r0948, r0949, r2109, r2130, r2133, r2136		
r0964[0...6]	Device identification / Device ident		
	Access level: 2	Calculated: -	Data type: Unsigned16
	Can be changed: -	Scaling: -	Dyn. index: -
	Unit group: -	Unit selection: -	Func. diagram: -
	Min	Max	Factory setting
	-	-	-
Description:	Displays the device identification.		
Index:	[0] = Company (Siemens = 42) [1] = Device type [2] = Firmware version [3] = Firmware date (year) [4] = Firmware date (day/month) [5] = Number of drive objects [6] = Firmware patch/hot fix		
Note:	Example: r0964[0] = 42 --> SIEMENS r0964[1] = device type, see below r0964[2] = 403 --> first part of the firmware version V04.03 (for second part, refer to index 6) r0964[3] = 2010 --> year 2010 r0964[4] = 1705 --> 17th of May r0964[5] = 2 --> 2 drive objects r0964[6] = 200 --> second part, firmware version (complete version: V04.03.02.00) Device type: r0964[1] = 6721 --> SINAMICS G115D PN r0964[1] = 6723 --> SINAMICS G115D I/O r0964[1] = 6724 --> SINAMICS G115D ASi		

r0965	PROFdrive profile number / PD profile number		
G115D PN	Access level: 3	Calculated: -	Data type: Unsigned16
	Can be changed: -	Scaling: -	Dyn. index: -
	Unit group: -	Unit selection: -	Func. diagram: -
	Min	Max	Factory setting
	-	-	-
Description:	Displays the PROFdrive profile number and profile version. Constant value = 0329 hex. Byte 1: Profile number = 03 hex = PROFdrive profile Byte 2: Profile version = 29 hex = Version 4.1		
Note:	When the parameter is read via PROFdrive, the Octet String 2 data type applies.		
p0969	System runtime relative / t_System relative		
	Access level: 3	Calculated: -	Data type: Unsigned32
	Can be changed: T	Scaling: -	Dyn. index: -
	Unit group: -	Unit selection: -	Func. diagram: 8050, 8060
	Min	Max	Factory setting
	0 [ms]	4294967295 [ms]	0 [ms]
Description:	Displays the system runtime in ms since the last POWER ON.		
Note:	The value in p0969 can only be reset to 0. The value overflows after approx. 49 days. When the parameter is read via PROFdrive, the TimeDifference data type applies.		
p0970	Reset drive parameters / Drive par reset		
	Access level: 1	Calculated: -	Data type: Unsigned16
	Can be changed: C(1, 30)	Scaling: -	Dyn. index: -
	Unit group: -	Unit selection: -	Func. diagram: -
	Min	Max	Factory setting
	0	300	0
Description:	The parameter is used to initiate the reset of the drive parameters. Parameters p0100, p0205 are not reset. The following motor parameters are defined in accordance with the power unit: p0300 ... p0311.		
Value:	0: Inactive 1: Start a parameter reset 3: Start download of volatile parameters from RAM 5: Starts a safety parameter reset 10: Start loading the parameters saved with p0971=10 11: Start loading the parameters saved with p0971=11 12: Start loading the parameters saved with p0971=12 30: Start loading the delivery state saved with p0971=30 100: Start a BICO interconnection reset 300: Only Siemens internal		
Dependency:	Refer to: F01659		
Notice:	After the value has been modified, no further parameter modifications can be made and the status is shown in r3996. Modifications can be made again when r3996 = 0.		

Note: A factory setting run can only be started if p0010 was first set to 30 (parameter reset).
 At the end of the calculations, p0970 is automatically set to 0.
 Parameter reset is completed with p0970 = 0 and r3996[0] = 0.
 For p0970 = 5 the following applies:
 The password for Safety Integrated must be set.
 When Safety Integrated is enabled, this can result in messages, which then require an acceptance test to be performed.
 Then save the parameters and carry out a POWER ON.
 For p0970 = 1 the following applies:
 If a Safety Integrated Function is parameterized (p9601), then the safety parameters are not reset. In this case, a fault (F01659) is output with fault value 2.
 The following generally applies:
 One index of parameters p2100, p2101, p2118, p2119, p2126, p2127 is not reset, if a parameterized message is precisely active in this index.

p0971	Save parameters / Save par		
	Access level: 1	Calculated: -	Data type: Unsigned16
	Can be changed: U, T	Scaling: -	Dyn. index: -
	Unit group: -	Unit selection: -	Func. diagram: -
	Min	Max	Factory setting
	0	30	0

Description: Setting to save parameters in the non-volatile memory.
 When saving, only the adjustable parameters intended to be saved are taken into account.

Value: 0: Inactive
 1: Save drive object
 10: Save in non-volatile memory as setting 10
 11: Save in non-volatile memory as setting 11
 12: Save in non-volatile memory as setting 12
 30: State when delivered, save in non-volatile memory as setting 30

Dependency: Refer to: p0970, p1960, p3845, r3996

Caution: If a memory card (optional) is inserted – and the USB interface is not used, the following applies:
 The parameters are also saved on the card and therefore overwrite any existing data!



Notice: The Control Unit power supply may only be switched off after data has been saved (i.e. after data save has been started, wait until the parameter again has the value 0).
 Writing to parameters is inhibited while saving.
 The progress while saving is displayed in r3996.
 For p0971 = 30:
 The original state when delivered is overwritten when executing this memory function.

Note: Parameters saved with p0971 = 10, 11, 12 can be loaded again with p0970 = 10, 11 or 12.
 Identification and maintenance data (I&M data, p8806 and following) are only saved for p0971 = 1.

p0972	Drive unit reset / Drv_unit reset		
	Access level: 3	Calculated: -	Data type: Unsigned16
	Can be changed: U, T	Scaling: -	Dyn. index: -
	Unit group: -	Unit selection: -	Func. diagram: -
	Min	Max	Factory setting
	0	3	0

Description: Sets the required procedure to execute a hardware reset for the drive unit.

Value: 0: Inactive
 1: Hardware-Reset immediate
 2: Hardware reset preparation
 3: Hardware reset after cyclic communication has failed

Danger:



It must be absolutely ensured that the system is in a safe condition.
 The memory card/device memory of the Control Unit must not be accessed.

Note: For value = 1:
 Reset is immediately executed and communications interrupted.
 After communications have been established, check the reset operation (refer below).
 If value = 2:
 Help to check the reset operation.
 Firstly, set p0972 = 2 and then read back. Secondly, set p0972 = 1 (it is possible that this request is possibly no longer acknowledged). The communication is then interrupted.
 After communications have been established, check the reset operation (refer below).
 If value = 3:
 The reset is executed after interrupting cyclic communication. This setting is used to implement a synchronized reset by a control for several drive units.
 If cyclic communication is not active, then the reset is immediately executed.
 After communications have been established, check the reset operation (refer below).
 To check the reset operation:
 After the drive unit has been restarted and communications have been established, read p0972 and check the following:
 p0972 = 0? --> the reset was successfully executed.
 p0972 = 0? --> the reset was not executed.

r0979[0...30]	PROFIdrive encoder format / PD encoder format		
	Access level: 3	Calculated: -	Data type: Unsigned32
	Can be changed: -	Scaling: -	Dyn. index: -
	Unit group: -	Unit selection: -	Func. diagram: 4704
	Min	Max	Factory setting
	-	-	-
Description:	Displays the actual position encoder used according to PROFIdrive.		
Index:	[0] = Header [1] = Type encoder 1 [2] = Resolution encoder 1 [3] = Shift factor G1_XIST1 [4] = Shift factor G1_XIST2 [5] = Distinguishable revolutions encoder 1 [6...30] = Reserved		
Note:	Information about the individual indices can be taken from the following literature: PROFIdrive Profile Drive Technology		

r0980[0...299]	List of existing parameters 1 / List avail par 1		
	Access level: 4	Calculated: -	Data type: Unsigned16
	Can be changed: -	Scaling: -	Dyn. index: -
	Unit group: -	Unit selection: -	Func. diagram: -
	Min	Max	Factory setting
	-	-	-
Description:	Displays the parameters that exist for this drive.		
Dependency:	Refer to: r0981, r0989		
Note:	Modified parameters are displayed in indices 0 to 298. If an index contains the value 0, then the list ends here. In a long list, index 299 contains the parameter number at which position the list continues. This list consists solely of the following parameters: r0980[0...299], r0981[0...299] ... r0989[0...299] The parameters in this list are not displayed in the expert list of the commissioning software. However, they can be read from a higher-level control system (e.g. PROFIBUS master).		

r0981[0...299]	List of existing parameters 2 / List avail par 2		
	Access level: 4	Calculated: -	Data type: Unsigned16
	Can be changed: -	Scaling: -	Dyn. index: -
	Unit group: -	Unit selection: -	Func. diagram: -
	Min	Max	Factory setting
	-	-	-
Description:	Displays the parameters that exist for this drive.		
Dependency:	Refer to: r0980, r0989		
Note:	Modified parameters are displayed in indices 0 to 298. If an index contains the value 0, then the list ends here. In a long list, index 299 contains the parameter number at which position the list continues. This list consists solely of the following parameters: r0980[0...299], r0981[0...299] ... r0989[0...299] The parameters in this list are not displayed in the expert list of the commissioning software. However, they can be read from a higher-level control system (e.g. PROFIBUS master).		
r0989[0...299]	List of existing parameters 10 / List avail par 10		
	Access level: 4	Calculated: -	Data type: Unsigned16
	Can be changed: -	Scaling: -	Dyn. index: -
	Unit group: -	Unit selection: -	Func. diagram: -
	Min	Max	Factory setting
	-	-	-
Description:	Displays the parameters that exist for this drive.		
Dependency:	Refer to: r0980, r0981		
Note:	Modified parameters are displayed in indices 0 to 298. If an index contains the value 0, then the list ends here. This list consists solely of the following parameters: r0980[0...299], r0981[0...299] ... r0989[0...299] The parameters in this list are not displayed in the expert list of the commissioning software. However, they can be read from a higher-level control system (e.g. PROFIBUS master).		
r0990[0...99]	List of modified parameters 1 / List chang par 1		
	Access level: 4	Calculated: -	Data type: Unsigned16
	Can be changed: -	Scaling: -	Dyn. index: -
	Unit group: -	Unit selection: -	Func. diagram: -
	Min	Max	Factory setting
	-	-	-
Description:	Displays those parameters with a value other than the factory setting for this drive.		
Dependency:	Refer to: r0991, r0999		
Note:	Modified parameters are displayed in indices 0 to 98. If an index contains the value 0, then the list ends here. In a long list, index 99 contains the parameter number at which position the list continues. This list consists solely of the following parameters: r0990[0...99], r0991[0...99] ... r0999[0...99] The parameters in this list are not displayed in the expert list of the commissioning software. However, they can be read from a higher-level control system (e.g. PROFIBUS master).		
r0991[0...99]	List of modified parameters 2 / List chang par 2		
	Access level: 4	Calculated: -	Data type: Unsigned16
	Can be changed: -	Scaling: -	Dyn. index: -
	Unit group: -	Unit selection: -	Func. diagram: -
	Min	Max	Factory setting
	-	-	-
Description:	Displays those parameters with a value other than the factory setting for this drive.		
Dependency:	Refer to: r0990, r0999		

Note: Modified parameters are displayed in indices 0 to 98. If an index contains the value 0, then the list ends here. In a long list, index 99 contains the parameter number at which position the list continues.
 This list consists solely of the following parameters:
 r0990[0...99], r0991[0...99] ... r0999[0...99]
 The parameters in this list are not displayed in the expert list of the commissioning software. However, they can be read from a higher-level control system (e.g. PROFIBUS master).

r0999[0...99]	List of modified parameters 10 / List chang par 10		
	Access level: 4	Calculated: -	Data type: Unsigned16
	Can be changed: -	Scaling: -	Dyn. index: -
	Unit group: -	Unit selection: -	Func. diagram: -
	Min	Max	Factory setting
	-	-	-
Description:	Displays those parameters with a value other than the factory setting for this drive.		
Dependency:	Refer to: r0990, r0991		
Note:	Modified parameters are displayed in indices 0 to 98. If an index contains the value 0, then the list ends here. This list consists solely of the following parameters: r0990[0...99], r0991[0...99] ... r0999[0...99] The parameters in this list are not displayed in the expert list of the commissioning software. However, they can be read from a higher-level control system (e.g. PROFIBUS master).		

p1000[0...n]	Speed setpoint selection / n_set sel		
G115D ASI	Access level: 1	Calculated: -	Data type: Integer16
	Can be changed: T	Scaling: -	Dyn. index: CDS, p0170
	Unit group: -	Unit selection: -	Func. diagram: -
	Min	Max	Factory setting
	0	77	3
Description:	Sets the source for the speed setpoint. For single-digit values, the following applies: The value specifies the main setpoint. For double-digit values, the following applies: The left-hand digit specifies the supplementary setpoint, the right-hand digit the main setpoint. Example: Value = 26 --> The analog setpoint (2) supplies the supplementary setpoint. --> The fieldbus (6) supplies the main setpoint.		

Value:	0:	No main setpoint
	1:	Motorized potentiometer
	2:	Analog setpoint
	3:	Fixed speed setpoint
	6:	Fieldbus
	7:	Analog setpoint 2
	10:	Motor potentiometer + no main setpoint
	11:	Motor potentiometer + motor potentiometer
	12:	Motor potentiometer + analog setpoint
	13:	Motor potentiometer + fixed speed setpoint
	16:	Motor potentiometer + fieldbus
	17:	Motor potentiometer + analog setpoint 2
	20:	Analog setpoint + no main setpoint
	21:	Analog setpoint + motor potentiometer
	22:	Analog setpoint + analog setpoint
	23:	Analog setpoint + fixed speed setpoint
	26:	Analog setpoint + fieldbus
	27:	Analog setpoint + analog setpoint 2
	30:	Fixed speed setpoint + no main setpoint
	31:	Fixed speed setpoint + motor potentiometer
	32:	Fixed speed setpoint + analog setpoint
	33:	Fixed speed setpoint + fixed speed setpoint
	36:	Fixed speed setpoint + fieldbus
	37:	Fixed speed setpoint + analog setpoint 2
	60:	Fieldbus + no main setpoint
	61:	Fieldbus + motor potentiometer
	62:	Fieldbus + analog setpoint
	63:	Fieldbus + fixed speed setpoint
	66:	Fieldbus+fieldbus
	67:	Fieldbus + analog setpoint 2
	70:	Analog setpoint 2 + no main setpoint
	71:	Analog setpoint 2 + motor potentiometer
	72:	Analog setpoint 2 + analog setpoint
	73:	Analog setpoint 2 + fixed speed setpoint
	76:	Analog setpoint 2 + fieldbus
	77:	Analog setpoint 2 + analog setpoint 2

Dependency: When changing this parameter, the following settings are influenced:

Refer to: p1070, p1071, p1075, p1076

Caution:



If p1000 is selected as the main setpoint of the fieldbus, the following BICO interconnection is set automatically:

p2051[1] = r0063

Notice:

The parameter is possibly protected as a result of p0922.

For PROFIBUS/PROFINET Control Units, the following applies: The parameter can be freely set by setting p0922 = 999.

When executing a specific macro, the corresponding programmed settings are made and become active.

p1000[0...n]	Speed setpoint selection / n_set sel		
G115D I/O	Access level: 1	Calculated: -	Data type: Integer16
	Can be changed: T	Scaling: -	Dyn. index: CDS, p0170
	Unit group: -	Unit selection: -	Func. diagram: -
	Min	Max	Factory setting
	0	77	[0] 2 [1] 7 [2] 0 [3] 0
Description:	<p>Sets the source for the speed setpoint. For single-digit values, the following applies: The value specifies the main setpoint. For double-digit values, the following applies: The left-hand digit specifies the supplementary setpoint, the right-hand digit the main setpoint. Example: Value = 26 --> The analog setpoint (2) supplies the supplementary setpoint. --> The fieldbus (6) supplies the main setpoint.</p>		
Value:	<p>0: No main setpoint 1: Motorized potentiometer 2: Analog setpoint 3: Fixed speed setpoint 7: Analog setpoint 2 10: Motor potentiometer + no main setpoint 11: Motor potentiometer + motor potentiometer 12: Motor potentiometer + analog setpoint 13: Motor potentiometer + fixed speed setpoint 17: Motor potentiometer + analog setpoint 2 20: Analog setpoint + no main setpoint 21: Analog setpoint + motor potentiometer 22: Analog setpoint + analog setpoint 23: Analog setpoint + fixed speed setpoint 27: Analog setpoint + analog setpoint 2 30: Fixed speed setpoint + no main setpoint 31: Fixed speed setpoint + motor potentiometer 32: Fixed speed setpoint + analog setpoint 33: Fixed speed setpoint + fixed speed setpoint 37: Fixed speed setpoint + analog setpoint 2 70: Analog setpoint 2 + no main setpoint 71: Analog setpoint 2 + motor potentiometer 72: Analog setpoint 2 + analog setpoint 73: Analog setpoint 2 + fixed speed setpoint 77: Analog setpoint 2 + analog setpoint 2</p>		
Dependency:	<p>When changing this parameter, the following settings are influenced: Refer to: p1070, p1071, p1075, p1076</p>		
Caution:	<p>If p1000 is selected as the main setpoint of the fieldbus, the following BICO interconnection is set automatically: p2051[1] = r0063</p>		
			
Notice:	<p>The parameter is possibly protected as a result of p0922. For PROFIBUS/PROFINET Control Units, the following applies: The parameter can be freely set by setting p0922 = 999. When executing a specific macro, the corresponding programmed settings are made and become active.</p>		

p1000[0...n]	Speed setpoint selection / n_set sel		
G115D PN	Access level: 1	Calculated: -	Data type: Integer16
	Can be changed: T	Scaling: -	Dyn. index: CDS, p0170
	Unit group: -	Unit selection: -	Func. diagram: -
	Min	Max	Factory setting
	0	77	[0] 6
			[1] 0
			[2] 0
			[3] 0

Description: Sets the source for the speed setpoint.
 For single-digit values, the following applies:
 The value specifies the main setpoint.
 For double-digit values, the following applies:
 The left-hand digit specifies the supplementary setpoint, the right-hand digit the main setpoint.
 Example:
 Value = 26
 --> The analog setpoint (2) supplies the supplementary setpoint.
 --> The fieldbus (6) supplies the main setpoint.

Value:

- 0: No main setpoint
- 1: Motorized potentiometer
- 2: Analog setpoint
- 3: Fixed speed setpoint
- 6: Fieldbus
- 7: Analog setpoint 2
- 10: Motor potentiometer + no main setpoint
- 11: Motor potentiometer + motor potentiometer
- 12: Motor potentiometer + analog setpoint
- 13: Motor potentiometer + fixed speed setpoint
- 16: Motor potentiometer + fieldbus
- 17: Motor potentiometer + analog setpoint 2
- 20: Analog setpoint + no main setpoint
- 21: Analog setpoint + motor potentiometer
- 22: Analog setpoint + analog setpoint
- 23: Analog setpoint + fixed speed setpoint
- 26: Analog setpoint + fieldbus
- 27: Analog setpoint + analog setpoint 2
- 30: Fixed speed setpoint + no main setpoint
- 31: Fixed speed setpoint + motor potentiometer
- 32: Fixed speed setpoint + analog setpoint
- 33: Fixed speed setpoint + fixed speed setpoint
- 36: Fixed speed setpoint + fieldbus
- 37: Fixed speed setpoint + analog setpoint 2
- 60: Fieldbus + no main setpoint
- 61: Fieldbus + motor potentiometer
- 62: Fieldbus + analog setpoint
- 63: Fieldbus + fixed speed setpoint
- 66: Fieldbus+fieldbus
- 67: Fieldbus + analog setpoint 2
- 70: Analog setpoint 2 + no main setpoint
- 71: Analog setpoint 2 + motor potentiometer
- 72: Analog setpoint 2 + analog setpoint
- 73: Analog setpoint 2 + fixed speed setpoint
- 76: Analog setpoint 2 + fieldbus
- 77: Analog setpoint 2 + analog setpoint 2

Dependency: When changing this parameter, the following settings are influenced:
 Refer to: p1070, p1071, p1075, p1076

Caution: If p1000 is selected as the main setpoint of the fieldbus, the following BICO interconnection is set automatically:
 p2051[1] = r0063



2 Parameters

2.2 List of parameters

Notice: The parameter is possibly protected as a result of p0922.
For PROFIBUS/PROFINET Control Units, the following applies: The parameter can be freely set by setting p0922 = 999.
When executing a specific macro, the corresponding programmed settings are made and become active.

p1001[0...n]	CO: Fixed speed setpoint 1 / n_set_fixed 1		
G115D ASI	Access level: 2	Calculated: -	Data type: FloatingPoint32
	Can be changed: U, T	Scaling: p2000	Dyn. index: DDS, p0180
	Unit group: 3_1	Unit selection: p0505	Func. diagram: 3010
	Min	Max	Factory setting
	-210000.000 [rpm]	210000.000 [rpm]	1500.000 [rpm]
Description:	Setting and connector output for fixed speed setpoint 1.		
Dependency:	Refer to: p1020, p1021, p1022, p1023, r1024, r1197		
Notice:	A BICO interconnection to a parameter that belongs to a drive data set always acts on the effective data set.		
p1001[0...n]	CO: Fixed speed setpoint 1 / n_set_fixed 1		
G115D I/O	Access level: 2	Calculated: -	Data type: FloatingPoint32
G115D PN	Can be changed: U, T	Scaling: p2000	Dyn. index: DDS, p0180
	Unit group: 3_1	Unit selection: p0505	Func. diagram: 3010
	Min	Max	Factory setting
	-210000.000 [rpm]	210000.000 [rpm]	0.000 [rpm]
Description:	Setting and connector output for fixed speed setpoint 1.		
Dependency:	Refer to: p1020, p1021, p1022, p1023, r1024, r1197		
Notice:	A BICO interconnection to a parameter that belongs to a drive data set always acts on the effective data set.		
p1002[0...n]	CO: Fixed speed setpoint 2 / n_set_fixed 2		
G115D ASI	Access level: 2	Calculated: -	Data type: FloatingPoint32
	Can be changed: U, T	Scaling: p2000	Dyn. index: DDS, p0180
	Unit group: 3_1	Unit selection: p0505	Func. diagram: 3010
	Min	Max	Factory setting
	-210000.000 [rpm]	210000.000 [rpm]	-1500.000 [rpm]
Description:	Setting and connector output for fixed speed setpoint 2.		
Dependency:	Refer to: p1020, p1021, p1022, p1023, r1024, r1197		
Notice:	A BICO interconnection to a parameter that belongs to a drive data set always acts on the effective data set.		
p1002[0...n]	CO: Fixed speed setpoint 2 / n_set_fixed 2		
G115D I/O	Access level: 2	Calculated: -	Data type: FloatingPoint32
G115D PN	Can be changed: U, T	Scaling: p2000	Dyn. index: DDS, p0180
	Unit group: 3_1	Unit selection: p0505	Func. diagram: 3010
	Min	Max	Factory setting
	-210000.000 [rpm]	210000.000 [rpm]	0.000 [rpm]
Description:	Setting and connector output for fixed speed setpoint 2.		
Dependency:	Refer to: p1020, p1021, p1022, p1023, r1024, r1197		
Notice:	A BICO interconnection to a parameter that belongs to a drive data set always acts on the effective data set.		
p1003[0...n]	CO: Fixed speed setpoint 3 / n_set_fixed 3		
G115D ASI	Access level: 2	Calculated: -	Data type: FloatingPoint32
	Can be changed: U, T	Scaling: p2000	Dyn. index: DDS, p0180
	Unit group: 3_1	Unit selection: p0505	Func. diagram: 3010
	Min	Max	Factory setting
	-210000.000 [rpm]	210000.000 [rpm]	300.000 [rpm]
Description:	Setting and connector output for fixed speed setpoint 3.		
Dependency:	Refer to: p1020, p1021, p1022, p1023, r1024, r1197		

Notice: A BICO interconnection to a parameter that belongs to a drive data set always acts on the effective data set.

p1003[0...n]	CO: Fixed speed setpoint 3 / n_set_fixed 3		
G115D I/O	Access level: 2	Calculated: -	Data type: FloatingPoint32
G115D PN	Can be changed: U, T	Scaling: p2000	Dyn. index: DDS, p0180
	Unit group: 3_1	Unit selection: p0505	Func. diagram: 3010
	Min	Max	Factory setting
	-210000.000 [rpm]	210000.000 [rpm]	0.000 [rpm]

Description: Setting and connector output for fixed speed setpoint 3.

Dependency: Refer to: p1020, p1021, p1022, p1023, r1024, r1197

Notice: A BICO interconnection to a parameter that belongs to a drive data set always acts on the effective data set.

p1004[0...n]	CO: Fixed speed setpoint 4 / n_set_fixed 4		
G115D ASI	Access level: 2	Calculated: -	Data type: FloatingPoint32
	Can be changed: U, T	Scaling: p2000	Dyn. index: DDS, p0180
	Unit group: 3_1	Unit selection: p0505	Func. diagram: 3010
	Min	Max	Factory setting
	-210000.000 [rpm]	210000.000 [rpm]	450.000 [rpm]

Description: Setting and connector output for fixed speed setpoint 4.

Dependency: Refer to: p1020, p1021, p1022, p1023, r1024, r1197

Notice: A BICO interconnection to a parameter that belongs to a drive data set always acts on the effective data set.

p1004[0...n]	CO: Fixed speed setpoint 4 / n_set_fixed 4		
G115D I/O	Access level: 2	Calculated: -	Data type: FloatingPoint32
G115D PN	Can be changed: U, T	Scaling: p2000	Dyn. index: DDS, p0180
	Unit group: 3_1	Unit selection: p0505	Func. diagram: 3010
	Min	Max	Factory setting
	-210000.000 [rpm]	210000.000 [rpm]	0.000 [rpm]

Description: Setting and connector output for fixed speed setpoint 4.

Dependency: Refer to: p1020, p1021, p1022, p1023, r1024, r1197

Notice: A BICO interconnection to a parameter that belongs to a drive data set always acts on the effective data set.

p1005[0...n]	CO: Fixed speed setpoint 5 / n_set_fixed 5		
G115D ASI	Access level: 2	Calculated: -	Data type: FloatingPoint32
	Can be changed: U, T	Scaling: p2000	Dyn. index: DDS, p0180
	Unit group: 3_1	Unit selection: p0505	Func. diagram: 3010
	Min	Max	Factory setting
	-210000.000 [rpm]	210000.000 [rpm]	600.000 [rpm]

Description: Setting and connector output for fixed speed setpoint 5.

Dependency: Refer to: p1020, p1021, p1022, p1023, r1024, r1197

Notice: A BICO interconnection to a parameter that belongs to a drive data set always acts on the effective data set.

p1005[0...n]	CO: Fixed speed setpoint 5 / n_set_fixed 5		
G115D I/O	Access level: 2	Calculated: -	Data type: FloatingPoint32
G115D PN	Can be changed: U, T	Scaling: p2000	Dyn. index: DDS, p0180
	Unit group: 3_1	Unit selection: p0505	Func. diagram: 3010
	Min	Max	Factory setting
	-210000.000 [rpm]	210000.000 [rpm]	0.000 [rpm]

Description: Setting and connector output for fixed speed setpoint 5.

Dependency: Refer to: p1020, p1021, p1022, p1023, r1024, r1197

Notice: A BICO interconnection to a parameter that belongs to a drive data set always acts on the effective data set.

2 Parameters

2.2 List of parameters

p1006[0...n]	CO: Fixed speed setpoint 6 / n_set_fixed 6		
G115D ASI	Access level: 2	Calculated: -	Data type: FloatingPoint32
	Can be changed: U, T	Scaling: p2000	Dyn. index: DDS, p0180
	Unit group: 3_1	Unit selection: p0505	Func. diagram: 3010
	Min	Max	Factory setting
	-210000.000 [rpm]	210000.000 [rpm]	750.000 [rpm]
Description:	Setting and connector output for fixed speed setpoint 6.		
Dependency:	Refer to: p1020, p1021, p1022, p1023, r1024, r1197		
Notice:	A BICO interconnection to a parameter that belongs to a drive data set always acts on the effective data set.		

p1006[0...n]	CO: Fixed speed setpoint 6 / n_set_fixed 6		
G115D I/O	Access level: 2	Calculated: -	Data type: FloatingPoint32
G115D PN	Can be changed: U, T	Scaling: p2000	Dyn. index: DDS, p0180
	Unit group: 3_1	Unit selection: p0505	Func. diagram: 3010
	Min	Max	Factory setting
	-210000.000 [rpm]	210000.000 [rpm]	0.000 [rpm]
Description:	Setting and connector output for fixed speed setpoint 6.		
Dependency:	Refer to: p1020, p1021, p1022, p1023, r1024, r1197		
Notice:	A BICO interconnection to a parameter that belongs to a drive data set always acts on the effective data set.		

p1007[0...n]	CO: Fixed speed setpoint 7 / n_set_fixed 7		
G115D ASI	Access level: 2	Calculated: -	Data type: FloatingPoint32
	Can be changed: U, T	Scaling: p2000	Dyn. index: DDS, p0180
	Unit group: 3_1	Unit selection: p0505	Func. diagram: 3010
	Min	Max	Factory setting
	-210000.000 [rpm]	210000.000 [rpm]	900.000 [rpm]
Description:	Setting and connector output for fixed speed setpoint 7.		
Dependency:	Refer to: p1020, p1021, p1022, p1023, r1024, r1197		
Notice:	A BICO interconnection to a parameter that belongs to a drive data set always acts on the effective data set.		

p1007[0...n]	CO: Fixed speed setpoint 7 / n_set_fixed 7		
G115D I/O	Access level: 2	Calculated: -	Data type: FloatingPoint32
G115D PN	Can be changed: U, T	Scaling: p2000	Dyn. index: DDS, p0180
	Unit group: 3_1	Unit selection: p0505	Func. diagram: 3010
	Min	Max	Factory setting
	-210000.000 [rpm]	210000.000 [rpm]	0.000 [rpm]
Description:	Setting and connector output for fixed speed setpoint 7.		
Dependency:	Refer to: p1020, p1021, p1022, p1023, r1024, r1197		
Notice:	A BICO interconnection to a parameter that belongs to a drive data set always acts on the effective data set.		

p1008[0...n]	CO: Fixed speed setpoint 8 / n_set_fixed 8		
G115D ASI	Access level: 2	Calculated: -	Data type: FloatingPoint32
	Can be changed: U, T	Scaling: p2000	Dyn. index: DDS, p0180
	Unit group: 3_1	Unit selection: p0505	Func. diagram: 3010
	Min	Max	Factory setting
	-210000.000 [rpm]	210000.000 [rpm]	1050.000 [rpm]
Description:	Setting and connector output for fixed speed setpoint 8.		
Dependency:	Refer to: p1020, p1021, p1022, p1023, r1024, r1197		
Notice:	A BICO interconnection to a parameter that belongs to a drive data set always acts on the effective data set.		

p1008[0...n]	CO: Fixed speed setpoint 8 / n_set_fixed 8		
G115D I/O	Access level: 2	Calculated: -	Data type: FloatingPoint32
G115D PN	Can be changed: U, T	Scaling: p2000	Dyn. index: DDS, p0180
	Unit group: 3_1	Unit selection: p0505	Func. diagram: 3010
	Min	Max	Factory setting
	-210000.000 [rpm]	210000.000 [rpm]	0.000 [rpm]
Description:	Setting and connector output for fixed speed setpoint 8.		
Dependency:	Refer to: p1020, p1021, p1022, p1023, r1024, r1197		
Notice:	A BICO interconnection to a parameter that belongs to a drive data set always acts on the effective data set.		
p1009[0...n]	CO: Fixed speed setpoint 9 / n_set_fixed 9		
G115D ASI	Access level: 2	Calculated: -	Data type: FloatingPoint32
	Can be changed: U, T	Scaling: p2000	Dyn. index: DDS, p0180
	Unit group: 3_1	Unit selection: p0505	Func. diagram: 3010
	Min	Max	Factory setting
	-210000.000 [rpm]	210000.000 [rpm]	1200.000 [rpm]
Description:	Setting and connector output for fixed speed setpoint 9.		
Dependency:	Refer to: p1020, p1021, p1022, p1023, r1024, r1197		
Notice:	A BICO interconnection to a parameter that belongs to a drive data set always acts on the effective data set.		
p1009[0...n]	CO: Fixed speed setpoint 9 / n_set_fixed 9		
G115D I/O	Access level: 2	Calculated: -	Data type: FloatingPoint32
G115D PN	Can be changed: U, T	Scaling: p2000	Dyn. index: DDS, p0180
	Unit group: 3_1	Unit selection: p0505	Func. diagram: 3010
	Min	Max	Factory setting
	-210000.000 [rpm]	210000.000 [rpm]	0.000 [rpm]
Description:	Setting and connector output for fixed speed setpoint 9.		
Dependency:	Refer to: p1020, p1021, p1022, p1023, r1024, r1197		
Notice:	A BICO interconnection to a parameter that belongs to a drive data set always acts on the effective data set.		
p1010[0...n]	CO: Fixed speed setpoint 10 / n_set_fixed 10		
G115D ASI	Access level: 2	Calculated: -	Data type: FloatingPoint32
	Can be changed: U, T	Scaling: p2000	Dyn. index: DDS, p0180
	Unit group: 3_1	Unit selection: p0505	Func. diagram: 3010
	Min	Max	Factory setting
	-210000.000 [rpm]	210000.000 [rpm]	1350.000 [rpm]
Description:	Setting and connector output for fixed speed setpoint 10.		
Dependency:	Refer to: p1020, p1021, p1022, p1023, r1024, r1197		
Notice:	A BICO interconnection to a parameter that belongs to a drive data set always acts on the effective data set.		
p1010[0...n]	CO: Fixed speed setpoint 10 / n_set_fixed 10		
G115D I/O	Access level: 2	Calculated: -	Data type: FloatingPoint32
G115D PN	Can be changed: U, T	Scaling: p2000	Dyn. index: DDS, p0180
	Unit group: 3_1	Unit selection: p0505	Func. diagram: 3010
	Min	Max	Factory setting
	-210000.000 [rpm]	210000.000 [rpm]	0.000 [rpm]
Description:	Setting and connector output for fixed speed setpoint 10.		
Dependency:	Refer to: p1020, p1021, p1022, p1023, r1024, r1197		
Notice:	A BICO interconnection to a parameter that belongs to a drive data set always acts on the effective data set.		

2 Parameters

2.2 List of parameters

p1011[0...n]	CO: Fixed speed setpoint 11 / n_set_fixed 11		
G115D ASI	Access level: 2	Calculated: -	Data type: FloatingPoint32
	Can be changed: U, T	Scaling: p2000	Dyn. index: DDS, p0180
	Unit group: 3_1	Unit selection: p0505	Func. diagram: 3010
	Min	Max	Factory setting
	-210000.000 [rpm]	210000.000 [rpm]	1500.000 [rpm]
Description:	Setting and connector output for fixed speed setpoint 11.		
Dependency:	Refer to: p1020, p1021, p1022, p1023, r1024, r1197		
Notice:	A BICO interconnection to a parameter that belongs to a drive data set always acts on the effective data set.		

p1011[0...n]	CO: Fixed speed setpoint 11 / n_set_fixed 11		
G115D I/O	Access level: 2	Calculated: -	Data type: FloatingPoint32
G115D PN	Can be changed: U, T	Scaling: p2000	Dyn. index: DDS, p0180
	Unit group: 3_1	Unit selection: p0505	Func. diagram: 3010
	Min	Max	Factory setting
	-210000.000 [rpm]	210000.000 [rpm]	0.000 [rpm]
Description:	Setting and connector output for fixed speed setpoint 11.		
Dependency:	Refer to: p1020, p1021, p1022, p1023, r1024, r1197		
Notice:	A BICO interconnection to a parameter that belongs to a drive data set always acts on the effective data set.		

p1012[0...n]	CO: Fixed speed setpoint 12 / n_set_fixed 12		
G115D ASI	Access level: 2	Calculated: -	Data type: FloatingPoint32
	Can be changed: U, T	Scaling: p2000	Dyn. index: DDS, p0180
	Unit group: 3_1	Unit selection: p0505	Func. diagram: 3010
	Min	Max	Factory setting
	-210000.000 [rpm]	210000.000 [rpm]	1650.000 [rpm]
Description:	Setting and connector output for fixed speed setpoint 12.		
Dependency:	Refer to: p1020, p1021, p1022, p1023, r1024, r1197		
Notice:	A BICO interconnection to a parameter that belongs to a drive data set always acts on the effective data set.		

p1012[0...n]	CO: Fixed speed setpoint 12 / n_set_fixed 12		
G115D I/O	Access level: 2	Calculated: -	Data type: FloatingPoint32
G115D PN	Can be changed: U, T	Scaling: p2000	Dyn. index: DDS, p0180
	Unit group: 3_1	Unit selection: p0505	Func. diagram: 3010
	Min	Max	Factory setting
	-210000.000 [rpm]	210000.000 [rpm]	0.000 [rpm]
Description:	Setting and connector output for fixed speed setpoint 12.		
Dependency:	Refer to: p1020, p1021, p1022, p1023, r1024, r1197		
Notice:	A BICO interconnection to a parameter that belongs to a drive data set always acts on the effective data set.		

p1013[0...n]	CO: Fixed speed setpoint 13 / n_set_fixed 13		
G115D ASI	Access level: 2	Calculated: -	Data type: FloatingPoint32
	Can be changed: U, T	Scaling: p2000	Dyn. index: DDS, p0180
	Unit group: 3_1	Unit selection: p0505	Func. diagram: 3010
	Min	Max	Factory setting
	-210000.000 [rpm]	210000.000 [rpm]	1800.000 [rpm]
Description:	Setting and connector output for fixed speed setpoint 13.		
Dependency:	Refer to: p1020, p1021, p1022, p1023, r1024, r1197		
Notice:	A BICO interconnection to a parameter that belongs to a drive data set always acts on the effective data set.		

p1013[0...n]	CO: Fixed speed setpoint 13 / n_set_fixed 13		
G115D I/O	Access level: 2	Calculated: -	Data type: FloatingPoint32
G115D PN	Can be changed: U, T	Scaling: p2000	Dyn. index: DDS, p0180
	Unit group: 3_1	Unit selection: p0505	Func. diagram: 3010
	Min	Max	Factory setting
	-210000.000 [rpm]	210000.000 [rpm]	0.000 [rpm]
Description:	Setting and connector output for fixed speed setpoint 13.		
Dependency:	Refer to: p1020, p1021, p1022, p1023, r1024, r1197		
Notice:	A BICO interconnection to a parameter that belongs to a drive data set always acts on the effective data set.		
p1014[0...n]	CO: Fixed speed setpoint 14 / n_set_fixed 14		
G115D ASI	Access level: 2	Calculated: -	Data type: FloatingPoint32
	Can be changed: U, T	Scaling: p2000	Dyn. index: DDS, p0180
	Unit group: 3_1	Unit selection: p0505	Func. diagram: 3010
	Min	Max	Factory setting
	-210000.000 [rpm]	210000.000 [rpm]	1950.000 [rpm]
Description:	Setting and connector output for fixed speed setpoint 14.		
Dependency:	Refer to: p1020, p1021, p1022, p1023, r1024, r1197		
Notice:	A BICO interconnection to a parameter that belongs to a drive data set always acts on the effective data set.		
p1014[0...n]	CO: Fixed speed setpoint 14 / n_set_fixed 14		
G115D I/O	Access level: 2	Calculated: -	Data type: FloatingPoint32
G115D PN	Can be changed: U, T	Scaling: p2000	Dyn. index: DDS, p0180
	Unit group: 3_1	Unit selection: p0505	Func. diagram: 3010
	Min	Max	Factory setting
	-210000.000 [rpm]	210000.000 [rpm]	0.000 [rpm]
Description:	Setting and connector output for fixed speed setpoint 14.		
Dependency:	Refer to: p1020, p1021, p1022, p1023, r1024, r1197		
Notice:	A BICO interconnection to a parameter that belongs to a drive data set always acts on the effective data set.		
p1015[0...n]	CO: Fixed speed setpoint 15 / n_set_fixed 15		
G115D ASI	Access level: 2	Calculated: -	Data type: FloatingPoint32
	Can be changed: U, T	Scaling: p2000	Dyn. index: DDS, p0180
	Unit group: 3_1	Unit selection: p0505	Func. diagram: 3010
	Min	Max	Factory setting
	-210000.000 [rpm]	210000.000 [rpm]	1950.000 [rpm]
Description:	Setting and connector output for fixed speed setpoint 15.		
Dependency:	Refer to: p1020, p1021, p1022, p1023, r1024, r1197		
Notice:	A BICO interconnection to a parameter that belongs to a drive data set always acts on the effective data set.		
p1015[0...n]	CO: Fixed speed setpoint 15 / n_set_fixed 15		
G115D I/O	Access level: 2	Calculated: -	Data type: FloatingPoint32
G115D PN	Can be changed: U, T	Scaling: p2000	Dyn. index: DDS, p0180
	Unit group: 3_1	Unit selection: p0505	Func. diagram: 3010
	Min	Max	Factory setting
	-210000.000 [rpm]	210000.000 [rpm]	0.000 [rpm]
Description:	Setting and connector output for fixed speed setpoint 15.		
Dependency:	Refer to: p1020, p1021, p1022, p1023, r1024, r1197		
Notice:	A BICO interconnection to a parameter that belongs to a drive data set always acts on the effective data set.		

p1016	Fixed speed setpoint select mode / n_set_fix select		
G115D ASI	Access level: 2	Calculated: -	Data type: Integer16
	Can be changed: T	Scaling: -	Dyn. index: -
	Unit group: -	Unit selection: -	Func. diagram: 3010, 3011
	Min	Max	Factory setting
	1	2	2
Description:	Sets the mode to select the fixed speed setpoint.		
Value:	1: Direct 2: Binary		
Note:	For p1016 = 1: In this mode, the setpoint is entered via the fixed speed setpoints p1001 ... p1004. Up to 16 different setpoints are obtained by adding the individual fixed speed setpoints. For p1016 = 2: In this mode, the setpoint is entered via the fixed speed setpoints p1001 ... p1015.		

p1016	Fixed speed setpoint select mode / n_set_fix select		
G115D I/O	Access level: 2	Calculated: -	Data type: Integer16
G115D PN	Can be changed: T	Scaling: -	Dyn. index: -
	Unit group: -	Unit selection: -	Func. diagram: 3010, 3011
	Min	Max	Factory setting
	1	2	1
Description:	Sets the mode to select the fixed speed setpoint.		
Value:	1: Direct 2: Binary		
Note:	For p1016 = 1: In this mode, the setpoint is entered via the fixed speed setpoints p1001 ... p1004. Up to 16 different setpoints are obtained by adding the individual fixed speed setpoints. For p1016 = 2: In this mode, the setpoint is entered via the fixed speed setpoints p1001 ... p1015.		

p1020[0...n]	BI: Fixed speed setpoint selection Bit 0 / n_set_fixed Bit 0		
G115D ASI	Access level: 3	Calculated: -	Data type: U32 / Binary
	Can be changed: T	Scaling: -	Dyn. index: CDS, p0170
	Unit group: -	Unit selection: -	Func. diagram: 2505, 3010, 3011
	Min	Max	Factory setting
	-	-	[0] 2093.0 [1] 0 [2] 0 [3] 0
Description:	Sets the signal source for selecting the fixed speed setpoint.		
Dependency:	Selects the required fixed speed setpoint using p1020 ... p1023. Displays the number of the actual fixed speed setpoint in r1197. Sets the values for the fixed speed setpoints 1 ... 15 using p1001 ... p1015. Refer to: p1021, p1022, p1023, r1197		
Note:	If a fixed speed setpoint has not been selected (p1020 ... p1023 = 0, r1197 = 0), then r1024 = 0 (setpoint = 0).		

p1020[0...n]	BI: Fixed speed setpoint selection Bit 0 / n_set_fixed Bit 0		
G115D I/O	Access level: 3	Calculated: -	Data type: U32 / Binary
	Can be changed: T	Scaling: -	Dyn. index: CDS, p0170
	Unit group: -	Unit selection: -	Func. diagram: 2505, 3010, 3011
	Min	Max	Factory setting
	-	-	[0] 0
			[1] 1
			[2] 0
			[3] 0
Description:	Sets the signal source for selecting the fixed speed setpoint.		
Dependency:	Selects the required fixed speed setpoint using p1020 ... p1023. Displays the number of the actual fixed speed setpoint in r1197. Sets the values for the fixed speed setpoints 1 ... 15 using p1001 ... p1015. Refer to: p1021, p1022, p1023, r1197		
Note:	If a fixed speed setpoint has not been selected (p1020 ... p1023 = 0, r1197 = 0), then r1024 = 0 (setpoint = 0).		
p1020[0...n]	BI: Fixed speed setpoint selection Bit 0 / n_set_fixed Bit 0		
G115D PN	Access level: 3	Calculated: -	Data type: U32 / Binary
	Can be changed: T	Scaling: -	Dyn. index: CDS, p0170
	Unit group: -	Unit selection: -	Func. diagram: 2505, 3010, 3011
	Min	Max	Factory setting
	-	-	0
Description:	Sets the signal source for selecting the fixed speed setpoint.		
Dependency:	Selects the required fixed speed setpoint using p1020 ... p1023. Displays the number of the actual fixed speed setpoint in r1197. Sets the values for the fixed speed setpoints 1 ... 15 using p1001 ... p1015. Refer to: p1021, p1022, p1023, r1197		
Note:	If a fixed speed setpoint has not been selected (p1020 ... p1023 = 0, r1197 = 0), then r1024 = 0 (setpoint = 0).		
p1021[0...n]	BI: Fixed speed setpoint selection Bit 1 / n_set_fixed Bit 1		
G115D ASI	Access level: 3	Calculated: -	Data type: U32 / Binary
	Can be changed: T	Scaling: -	Dyn. index: CDS, p0170
	Unit group: -	Unit selection: -	Func. diagram: 2505, 3010, 3011
	Min	Max	Factory setting
	-	-	[0] 2093.1
			[1] 0
			[2] 0
			[3] 0
Description:	Sets the signal source for selecting the fixed speed setpoint.		
Dependency:	Selects the required fixed speed setpoint using p1020 ... p1023. Displays the number of the actual fixed speed setpoint in r1197. Sets the values for the fixed speed setpoints 1 ... 15 using p1001 ... p1015. Refer to: p1020, p1022, p1023, r1197		
Note:	If a fixed speed setpoint has not been selected (p1020 ... p1023 = 0, r1197 = 0), then r1024 = 0 (setpoint = 0).		
p1021[0...n]	BI: Fixed speed setpoint selection Bit 1 / n_set_fixed Bit 1		
G115D I/O	Access level: 3	Calculated: -	Data type: U32 / Binary
G115D PN	Can be changed: T	Scaling: -	Dyn. index: CDS, p0170
	Unit group: -	Unit selection: -	Func. diagram: 2505, 3010, 3011
	Min	Max	Factory setting
	-	-	0
Description:	Sets the signal source for selecting the fixed speed setpoint.		

2 Parameters

2.2 List of parameters

Dependency: Selects the required fixed speed setpoint using p1020 ... p1023.
Displays the number of the actual fixed speed setpoint in r1197.
Sets the values for the fixed speed setpoints 1 ... 15 using p1001 ... p1015.
Refer to: p1020, p1022, p1023, r1197

Note: If a fixed speed setpoint has not been selected (p1020 ... p1023 = 0, r1197 = 0), then r1024 = 0 (setpoint = 0).

p1022[0...n] **BI: Fixed speed setpoint selection Bit 2 / n_set_fixed Bit 2**

G115D ASI	Access level: 3	Calculated: -	Data type: U32 / Binary
	Can be changed: T	Scaling: -	Dyn. index: CDS, p0170
	Unit group: -	Unit selection: -	Func. diagram: 2505, 3010, 3011
	Min	Max	Factory setting
	-	-	[0] 2093.2
			[1] 0
			[2] 0
			[3] 0

Description: Sets the signal source for selecting the fixed speed setpoint.

Dependency: Selects the required fixed speed setpoint using p1020 ... p1023.
Displays the number of the actual fixed speed setpoint in r1197.
Sets the values for the fixed speed setpoints 1 ... 15 using p1001 ... p1015.
Refer to: p1020, p1021, p1023, r1197

Note: If a fixed speed setpoint has not been selected (p1020 ... p1023 = 0, r1197 = 0), then r1024 = 0 (setpoint = 0).

p1022[0...n] **BI: Fixed speed setpoint selection Bit 2 / n_set_fixed Bit 2**

G115D I/O	Access level: 3	Calculated: -	Data type: U32 / Binary
G115D PN	Can be changed: T	Scaling: -	Dyn. index: CDS, p0170
	Unit group: -	Unit selection: -	Func. diagram: 2505, 3010, 3011
	Min	Max	Factory setting
	-	-	0

Description: Sets the signal source for selecting the fixed speed setpoint.

Dependency: Selects the required fixed speed setpoint using p1020 ... p1023.
Displays the number of the actual fixed speed setpoint in r1197.
Sets the values for the fixed speed setpoints 1 ... 15 using p1001 ... p1015.
Refer to: p1020, p1021, p1023, r1197

Note: If a fixed speed setpoint has not been selected (p1020 ... p1023 = 0, r1197 = 0), then r1024 = 0 (setpoint = 0).

p1023[0...n] **BI: Fixed speed setpoint selection Bit 3 / n_set_fixed Bit 3**

G115D ASI	Access level: 3	Calculated: -	Data type: U32 / Binary
	Can be changed: T	Scaling: -	Dyn. index: CDS, p0170
	Unit group: -	Unit selection: -	Func. diagram: 2505, 3010, 3011
	Min	Max	Factory setting
	-	-	[0] 2093.3
			[1] 0
			[2] 0
			[3] 0

Description: Sets the signal source for selecting the fixed speed setpoint.

Dependency: Selects the required fixed speed setpoint using p1020 ... p1023.
Displays the number of the actual fixed speed setpoint in r1197.
Sets the values for the fixed speed setpoints 1 ... 15 using p1001 ... p1015.
Refer to: p1020, p1021, p1022, r1197

Note: If a fixed speed setpoint has not been selected (p1020 ... p1023 = 0, r1197 = 0), then r1024 = 0 (setpoint = 0).

p1023[0...n]	BI: Fixed speed setpoint selection Bit 3 / n_set_fixed Bit 3			
G115D I/O	Access level: 3	Calculated: -	Data type: U32 / Binary	
G115D PN	Can be changed: T	Scaling: -	Dyn. index: CDS, p0170	
	Unit group: -	Unit selection: -	Func. diagram: 2505, 3010, 3011	
	Min	Max	Factory setting	
	-	-	0	
Description:	Sets the signal source for selecting the fixed speed setpoint.			
Dependency:	Selects the required fixed speed setpoint using p1020 ... p1023. Displays the number of the actual fixed speed setpoint in r1197. Sets the values for the fixed speed setpoints 1 ... 15 using p1001 ... p1015. Refer to: p1020, p1021, p1022, r1197			
Note:	If a fixed speed setpoint has not been selected (p1020 ... p1023 = 0, r1197 = 0), then r1024 = 0 (setpoint = 0).			
r1024	CO: Fixed speed setpoint effective / Speed fixed setp			
	Access level: 3	Calculated: -	Data type: FloatingPoint32	
	Can be changed: -	Scaling: p2000	Dyn. index: -	
	Unit group: 3_1	Unit selection: p0505	Func. diagram: 3001, 3010, 3011	
	Min	Max	Factory setting	
	- [rpm]	- [rpm]	- [rpm]	
Description:	Display and connector output for the selected and active fixed speed setpoint. This setpoint is the output value for the fixed speed setpoints and must be appropriately interconnected (e.g. with the main setpoint).			
Recommendation:	Interconnect the signal with the main setpoint (CI: p1070 = r1024).			
Dependency:	Selects the required fixed speed setpoint using p1020 ... p1023. Displays the number of the actual fixed speed setpoint in r1197. Sets the values for the fixed speed setpoints 1 ... 15 using p1001 ... p1015. Refer to: p1070, r1197			
Note:	If a fixed speed setpoint has not been selected (p1020 ... p1023 = 0, r1197 = 0), then r1024 = 0 (setpoint = 0).			
r1025.0	BO: Fixed speed setpoint status / n_setp_fix status			
	Access level: 3	Calculated: -	Data type: Unsigned8	
	Can be changed: -	Scaling: -	Dyn. index: -	
	Unit group: -	Unit selection: -	Func. diagram: -	
	Min	Max	Factory setting	
	-	-	-	
Description:	Display and binector output for the status when selecting the fixed speed setpoints.			
Bit field:	Bit	Signal name	1 signal	0 signal
	00	Fixed speed setpoint selected	Yes	No
				FP
				3011
Dependency:	Refer to: p1016			
Note:	For bit 00: When the fixed speed setpoints are directly selected (p1016 = 1), this bit is set if at least 1 fixed speed setpoint is selected.			
p1030[0...n]	Motorized potentiometer configuration / Mop configuration			
	Access level: 3	Calculated: -	Data type: Unsigned16	
	Can be changed: U, T	Scaling: -	Dyn. index: DDS, p0180	
	Unit group: -	Unit selection: -	Func. diagram: 3020	
	Min	Max	Factory setting	
	-	-	0000 0110 bin	
Description:	Sets the configuration for the motorized potentiometer.			

2 Parameters

2.2 List of parameters

Bit field:	Bit	Signal name	1 signal	0 signal	FP
	00	Data save active	Yes	No	-
	01	Automatic mode ramp-function generator active	Yes	No	-
	02	Initial rounding-off active	Yes	No	-
	03	Save in NVRAM active	Yes	No	-
	04	Ramp-function generator always active	Yes	No	-

Note:

For bit 00:

0: The setpoint for the motorized potentiometer is not saved and after ON is entered using p1040.

1: The setpoint for the motorized potentiometer is saved after OFF and after ON set to the saved value. In order to save in a non-volatile fashion, bit 03 should be set to 1.

For bit 01:

0: Without ramp-function generator in the automatic mode (ramp-up/ramp-down time = 0).

1: With ramp-function generator in the automatic mode.

For manual operation (0 signal via BI: p1041), the ramp-function generator is always active.

For bit 02:

0: Without initial rounding-off

1: With initial rounding-off. The selected ramp-up/down time is correspondingly exceeded. The initial rounding-off is a sensitive way of specifying small changes (progressive reaction when keys are pressed).

The jerk for the initial rounding-off is independent of the ramp-up time and only depends on the selected maximum speed (p1082). It is calculated as follows:

$$r = 0.01 \% * p1082 [1/s] / 0.13^2 [s^2]$$

The jerk acts up until the maximum acceleration is reached ($a_{max} = p1082 [1/s] / p1047 [s]$), and then the drive continues to run linearly with a constant rate of acceleration. The higher the maximum acceleration (the lower that p1047 is), the longer the ramp-up time increases with respect to the set ramp-up time.

For bit 03:

0: Non-volatile data save deactivated.

1: The setpoint for the motorized potentiometer is saved in a non-volatile fashion (for bit 00 = 1).

For bit 04:

When the bit is set, the ramp-function generator is computed independent of the pulse enable. The actual output value of the motorized potentiometer is always in r1050.

p1035[0...n]	BI: Motorized potentiometer setpoint raise / Mop raise		
Access level: 3	Calculated: -	Data type: U32 / Binary	
Can be changed: T	Scaling: -	Dyn. index: CDS, p0170	
Unit group: -	Unit selection: -	Func. diagram: 2505, 3020	
Min	Max	Factory setting	
-	-	0	

Description:

Sets the signal source to continually increase the setpoint for the motorized potentiometer.

The setpoint change (CO: r1050) depends on the set ramp-up time (p1047) and the duration of the signal that is present (BI: p1035).

Dependency:

Refer to: p1036

Notice:

The parameter may be protected as a result of p0922 or p2079 and cannot be changed.

p1036[0...n]	BI: Motorized potentiometer lower setpoint / Mop lower		
Access level: 3	Calculated: -	Data type: U32 / Binary	
Can be changed: T	Scaling: -	Dyn. index: CDS, p0170	
Unit group: -	Unit selection: -	Func. diagram: 2505, 3020	
Min	Max	Factory setting	
-	-	0	

Description:

Sets the signal source to continuously lower the setpoint for the motorized potentiometer.

The setpoint change (CO: r1050) depends on the set ramp-down time (p1048) and the duration of the signal that is present (BI: p1036).

Dependency:

Refer to: p1035

Notice:

The parameter may be protected as a result of p0922 or p2079 and cannot be changed.

p1037[0...n]	Motorized potentiometer maximum speed / MotP n_max		
	Access level: 3	Calculated: p0340 = 1,3,5	Data type: FloatingPoint32
	Can be changed: U, T	Scaling: -	Dyn. index: DDS, p0180
	Unit group: 3_1	Unit selection: p0505	Func. diagram: 3020
	Min	Max	Factory setting
	-210000.000 [rpm]	210000.000 [rpm]	0.000 [rpm]
Description:	Sets the maximum speed/velocity for the motorized potentiometer.		
Note:	This parameter is automatically pre-assigned in the commissioning phase. The setpoint output from the motorized potentiometer is limited to this value (see function diagram 3020).		
p1038[0...n]	Motorized potentiometer minimum speed / MotP n_min		
	Access level: 3	Calculated: p0340 = 1,3,5	Data type: FloatingPoint32
	Can be changed: U, T	Scaling: -	Dyn. index: DDS, p0180
	Unit group: 3_1	Unit selection: p0505	Func. diagram: 3020
	Min	Max	Factory setting
	-210000.000 [rpm]	210000.000 [rpm]	0.000 [rpm]
Description:	Sets the minimum speed/velocity for the motorized potentiometer.		
Note:	This parameter is automatically pre-assigned in the commissioning phase. The setpoint output from the motorized potentiometer is limited to this value (see function diagram 3020).		
p1039[0...n]	BI: Motorized potentiometer inversion / MotP inv		
	Access level: 3	Calculated: -	Data type: U32 / Binary
	Can be changed: T	Scaling: -	Dyn. index: CDS, p0170
	Unit group: -	Unit selection: -	Func. diagram: 3020
	Min	Max	Factory setting
	-	-	0
Description:	Sets the signal source to invert the minimum speed/velocity or the maximum speed/velocity for the motorized potentiometer.		
Dependency:	Refer to: p1037, p1038		
Note:	The inversion is only active during "motorized potentiometer raise" or "motorized potentiometer lower".		
p1040[0...n]	Motorized potentiometer starting value / Mop start value		
	Access level: 2	Calculated: -	Data type: FloatingPoint32
	Can be changed: U, T	Scaling: -	Dyn. index: DDS, p0180
	Unit group: 3_1	Unit selection: p0505	Func. diagram: 3020
	Min	Max	Factory setting
	-210000.000 [rpm]	210000.000 [rpm]	0.000 [rpm]
Description:	Sets the starting value for the motorized potentiometer. This starting value becomes effective after the drive has been switched on.		
Dependency:	Only effective if p1030.0 = 0. Refer to: p1030		
p1041[0...n]	BI: Motorized potentiometer manual/automatic / Mop manual/auto		
	Access level: 3	Calculated: -	Data type: U32 / Binary
	Can be changed: T	Scaling: -	Dyn. index: CDS, p0170
	Unit group: -	Unit selection: -	Func. diagram: 3020
	Min	Max	Factory setting
	-	-	0
Description:	Sets the signal source to change over from manual to automatic when using a motorized potentiometer. In the manual mode, the setpoint is changed using two signals - raise and lower. In the automatic mode, the setpoint must be interconnected via a connector input.		
Dependency:	Refer to: p1030, p1035, p1036, p1042		

Note: The effectiveness of the internal ramp-function generator can be set in automatic mode.

p1042[0...n]	CI: Motorized potentiometer automatic setpoint / Mop auto setpoint		
	Access level: 3	Calculated: -	Data type: U32 / FloatingPoint32
	Can be changed: T	Scaling: p2000	Dyn. index: CDS, p0170
	Unit group: -	Unit selection: -	Func. diagram: 3020
	Min	Max	Factory setting
	-	-	0

Description: Sets the signal source for the setpoint of the motorized potentiometer in the automatic mode.
Dependency: Refer to: p1041

p1043[0...n]	BI: Motorized potentiometer accept setting value / MotP acc set val		
	Access level: 3	Calculated: -	Data type: U32 / Binary
	Can be changed: T	Scaling: -	Dyn. index: CDS, p0170
	Unit group: -	Unit selection: -	Func. diagram: 3020
	Min	Max	Factory setting
	-	-	0

Description: Sets the signal source to accept the setting value for the motorized potentiometer.
Dependency: Refer to: p1044
Note: The setting value (CI: p1044) becomes effective for a 0/1 edge of the setting command (BI: p1043).

p1044[0...n]	CI: Motorized potentiometer setting value / Mop set val		
	Access level: 3	Calculated: -	Data type: U32 / FloatingPoint32
	Can be changed: T	Scaling: p2000	Dyn. index: CDS, p0170
	Unit group: -	Unit selection: -	Func. diagram: 3020
	Min	Max	Factory setting
	-	-	0

Description: Sets the signal source for the setting value for the motorized potentiometer.
Dependency: Refer to: p1043
Note: The setting value (CI: p1044) becomes effective for a 0/1 edge of the setting command (BI: p1043).

r1045	CO: Mot. potentiometer speed setp. in front of ramp-fct. gen. / Mop n_set bef RFG		
	Access level: 3	Calculated: -	Data type: FloatingPoint32
	Can be changed: -	Scaling: p2000	Dyn. index: -
	Unit group: 3_1	Unit selection: p0505	Func. diagram: 3020
	Min	Max	Factory setting
	- [rpm]	- [rpm]	- [rpm]

Description: Displays the effective setpoint in front of the internal motorized potentiometer ramp-function generator.

p1047[0...n]	Motorized potentiometer ramp-up time / Mop ramp-up time		
	Access level: 2	Calculated: -	Data type: FloatingPoint32
	Can be changed: U, T	Scaling: -	Dyn. index: DDS, p0180
	Unit group: -	Unit selection: -	Func. diagram: 3020
	Min	Max	Factory setting
	0.000 [s]	1000.000 [s]	10.000 [s]

Description: Sets the ramp-up time for the internal ramp-function generator for the motorized potentiometer. The setpoint is changed from zero up to the speed/velocity limit (p1082) within this time (if no initial rounding-off has been activated).
Dependency: Refer to: p1030, p1048, p1082
Note: When the initial rounding-off is activated (p1030.2) the ramp-up time is correspondingly extended.

p1048[0...n]	Motorized potentiometer ramp-down time / Mop ramp-down time		
	Access level: 2	Calculated: -	Data type: FloatingPoint32
	Can be changed: U, T	Scaling: -	Dyn. index: DDS, p0180
	Unit group: -	Unit selection: -	Func. diagram: 3020
	Min	Max	Factory setting
	0.000 [s]	1000.000 [s]	10.000 [s]
Description:	Sets the ramp-down time for the internal ramp-function generator for the motorized potentiometer. The setpoint is changed from the speed/velocity limit (p1082) to zero within this time (if no initial rounding-off has been activated).		
Dependency:	Refer to: p1030, p1047, p1082		
Note:	The deceleration time is extended corresponding to the activated initial rounding-off (p1030.2).		
r1050	CO: Motorized potentiometer setpoint after ramp-function generator / Mot poti setpoint		
	Access level: 2	Calculated: -	Data type: FloatingPoint32
	Can be changed: -	Scaling: p2000	Dyn. index: -
	Unit group: 3_1	Unit selection: p0505	Func. diagram: 3001, 3020
	Min	Max	Factory setting
	- [rpm]	- [rpm]	- [rpm]
Description:	Displays the effective setpoint after the internal motorized potentiometer ramp-function generator. This setpoint is the output value of the motorized potentiometer and must be appropriately interconnected onwards (e.g. with the main setpoint).		
Recommendation:	Interconnect the signal with main setpoint (p1070).		
Dependency:	Refer to: p1070		
Note:	For "With ramp-function generator", after an OFF1, OFF2, OFF3 or for a 0 signal via BI: p0852 (inhibit operation, suppress pulses) the ramp-function generator output (r1050) is set to the starting value (configuration via p1030.0).		
p1051[0...n]	CI: Speed limit RFG positive direction of rotation / n_limit RFG pos		
	Access level: 3	Calculated: -	Data type: U32 / FloatingPoint32
	Can be changed: T	Scaling: p2000	Dyn. index: CDS, p0170
	Unit group: -	Unit selection: -	Func. diagram: 3050
	Min	Max	Factory setting
	-	-	1083[0]
Description:	Sets the signal source for the speed limit of the positive direction on the ramp-function generator input.		
Note:	The OFF3 ramp-down time (p1135) is effective when the limit is reduced.		
p1052[0...n]	CI: Speed limit RFG negative direction of rotation / n_limit RFG neg		
	Access level: 3	Calculated: -	Data type: U32 / FloatingPoint32
	Can be changed: T	Scaling: p2000	Dyn. index: CDS, p0170
	Unit group: -	Unit selection: -	Func. diagram: 3050
	Min	Max	Factory setting
	-	-	1086[0]
Description:	Sets the signal source for the speed limit of the negative direction on the ramp-function generator input.		
Note:	The OFF3 ramp-down time (p1135) is effective when the limit is reduced.		
p1055[0...n]	BI: Jog bit 0 / Jog bit 0		
G115D I/O	Access level: 3	Calculated: -	Data type: U32 / Binary
G115D ASI	Can be changed: T	Scaling: -	Dyn. index: CDS, p0170
	Unit group: -	Unit selection: -	Func. diagram: 2501, 3030
	Min	Max	Factory setting
	-	-	0
Description:	Sets the signal source for jog 1.		

2 Parameters

2.2 List of parameters

Recommendation: When the setting for this binector input is changed, the motor can only be switched on by means of an appropriate signal change of the source.

Dependency: Refer to: p0840, p1058

Notice: The drive is enabled for jogging using BI: p1055 or BI: p1056.
The command "ON/OFF1" can be issued using BI: p0840 or using BI: p1055/p1056.
Only the signal source that was used to switch on can also be used to switch off again.

p1055[0...n]	BI: Jog bit 0 / Jog bit 0		
G115D PN	Access level: 3	Calculated: -	Data type: U32 / Binary
	Can be changed: T	Scaling: -	Dyn. index: CDS, p0170
	Unit group: -	Unit selection: -	Func. diagram: 2501, 3030
	Min	Max	Factory setting
	-	-	[0] 0
			[1] 722.0
			[2] 0
			[3] 0

Description: Sets the signal source for jog 1.

Recommendation: When the setting for this binector input is changed, the motor can only be switched on by means of an appropriate signal change of the source.

Dependency: Refer to: p0840, p1058

Notice: The drive is enabled for jogging using BI: p1055 or BI: p1056.
The command "ON/OFF1" can be issued using BI: p0840 or using BI: p1055/p1056.
Only the signal source that was used to switch on can also be used to switch off again.

p1056[0...n]	BI: Jog bit 1 / Jog bit 1		
G115D I/O	Access level: 3	Calculated: -	Data type: U32 / Binary
G115D ASI	Can be changed: T	Scaling: -	Dyn. index: CDS, p0170
	Unit group: -	Unit selection: -	Func. diagram: 2501, 3030
	Min	Max	Factory setting
	-	-	0

Description: Sets the signal source for jog 2.

Recommendation: When the setting for this binector input is changed, the motor can only be switched on by means of an appropriate signal change of the source.

Dependency: Refer to: p0840, p1059

Notice: The drive is enabled for jogging using BI: p1055 or BI: p1056.
The command "ON/OFF1" can be issued using BI: p0840 or using BI: p1055/p1056.
Only the signal source that was used to switch on can also be used to switch off again.

p1056[0...n]	BI: Jog bit 1 / Jog bit 1		
G115D PN	Access level: 3	Calculated: -	Data type: U32 / Binary
	Can be changed: T	Scaling: -	Dyn. index: CDS, p0170
	Unit group: -	Unit selection: -	Func. diagram: 2501, 3030
	Min	Max	Factory setting
	-	-	[0] 0
			[1] 722.1
			[2] 0
			[3] 0

Description: Sets the signal source for jog 2.

Recommendation: When the setting for this binector input is changed, the motor can only be switched on by means of an appropriate signal change of the source.

Dependency: Refer to: p0840, p1059

Notice: The drive is enabled for jogging using BI: p1055 or BI: p1056.
The command "ON/OFF1" can be issued using BI: p0840 or using BI: p1055/p1056.
Only the signal source that was used to switch on can also be used to switch off again.

p1058[0...n]	Jog 1 speed setpoint / Jog 1 n_set		
	Access level: 2	Calculated: -	Data type: FloatingPoint32
	Can be changed: T	Scaling: -	Dyn. index: DDS, p0180
	Unit group: 3_1	Unit selection: p0505	Func. diagram: 3001, 3030
	Min	Max	Factory setting
	-210000.000 [rpm]	210000.000 [rpm]	150.000 [rpm]
Description:	Sets the speed for jog 1. Jogging (JOG) is level-triggered, and allows the motor to be incrementally traversed.		
Dependency:	Refer to: p1055, p1056		
p1059[0...n]	Jog 2 speed setpoint / Jog 2 n_set		
	Access level: 2	Calculated: -	Data type: FloatingPoint32
	Can be changed: T	Scaling: -	Dyn. index: DDS, p0180
	Unit group: 3_1	Unit selection: p0505	Func. diagram: 3001, 3030
	Min	Max	Factory setting
	-210000.000 [rpm]	210000.000 [rpm]	-150.000 [rpm]
Description:	Sets the speed for jog 2. Jogging (JOG) is level-triggered, and allows the motor to be incrementally traversed.		
Dependency:	Refer to: p1055, p1056		
p1063[0...n]	Setpoint channel speed limit / Setp_chan n_lim		
	Access level: 3	Calculated: -	Data type: FloatingPoint32
	Can be changed: U, T	Scaling: -	Dyn. index: DDS, p0180
	Unit group: 3_1	Unit selection: p0505	Func. diagram: 3040
	Min	Max	Factory setting
	0.000 [rpm]	210000.000 [rpm]	210000.000 [rpm]
Description:	Sets the speed limit effective in the setpoint channel.		
Dependency:	Refer to: p1082, p1083, p1085, p1086, p1088		
p1070[0...n]	CI: Main setpoint / Main setpoint		
G115D ASI	Access level: 3	Calculated: -	Data type: U32 / FloatingPoint32
	Can be changed: T	Scaling: p2000	Dyn. index: CDS, p0170
	Unit group: -	Unit selection: -	Func. diagram: 3001, 3030
	Min	Max	Factory setting
	-	-	[0] 1024[0] [1] 0 [2] 0 [3] 0
Description:	Sets the signal source for the main setpoint. Examples: r1024: Fixed speed setpoint effective r1050: Motor. potentiometer setpoint after the ramp-function generator		
Dependency:	Refer to: p1071, r1073, r1078		
Notice:	The parameter may be protected as a result of p0922 or p2079 and cannot be changed.		

p1070[0...n]	CI: Main setpoint / Main setpoint		
G115D I/O	Access level: 3	Calculated: -	Data type: U32 / FloatingPoint32
	Can be changed: T	Scaling: p2000	Dyn. index: CDS, p0170
	Unit group: -	Unit selection: -	Func. diagram: 3001, 3030
	Min	Max	Factory setting
	-	-	[0] 755[0]
			[1] 755[1]
			[2] 0
			[3] 0
Description:	Sets the signal source for the main setpoint. Examples: r1024: Fixed speed setpoint effective r1050: Motor. potentiometer setpoint after the ramp-function generator		
Dependency:	Refer to: p1071, r1073, r1078		
Notice:	The parameter may be protected as a result of p0922 or p2079 and cannot be changed.		

p1070[0...n]	CI: Main setpoint / Main setpoint		
G115D PN	Access level: 3	Calculated: -	Data type: U32 / FloatingPoint32
	Can be changed: T	Scaling: p2000	Dyn. index: CDS, p0170
	Unit group: -	Unit selection: -	Func. diagram: 3001, 3030
	Min	Max	Factory setting
	-	-	[0] 2050[1]
			[1] 0
			[2] 0
			[3] 0
Description:	Sets the signal source for the main setpoint. Examples: r1024: Fixed speed setpoint effective r1050: Motor. potentiometer setpoint after the ramp-function generator		
Dependency:	Refer to: p1071, r1073, r1078		
Notice:	The parameter may be protected as a result of p0922 or p2079 and cannot be changed.		

p1071[0...n]	CI: Main setpoint scaling / Main setp scal		
	Access level: 3	Calculated: -	Data type: U32 / FloatingPoint32
	Can be changed: T	Scaling: PERCENT	Dyn. index: CDS, p0170
	Unit group: -	Unit selection: -	Func. diagram: 3001, 3030
	Min	Max	Factory setting
	-	-	1
Description:	Sets the signal source for scaling the main setpoint.		

r1073	CO: Main setpoint effective / Main setpoint eff		
	Access level: 3	Calculated: -	Data type: FloatingPoint32
	Can be changed: -	Scaling: p2000	Dyn. index: -
	Unit group: 3_1	Unit selection: p0505	Func. diagram: 3030
	Min	Max	Factory setting
	- [rpm]	- [rpm]	- [rpm]
Description:	Displays the effective main setpoint. The value shown is the main setpoint after scaling.		

p1075[0...n]	CI: Supplementary setp / Suppl setp		
	Access level: 3	Calculated: -	Data type: U32 / FloatingPoint32
	Can be changed: T	Scaling: p2000	Dyn. index: CDS, p0170
	Unit group: -	Unit selection: -	Func. diagram: 3001, 3030
	Min	Max	Factory setting
	-	-	0
Description:	Sets the signal source for the supplementary setpoint.		
Dependency:	Refer to: p1076, r1077, r1078		
p1076[0...n]	CI: Supplementary setpoint scaling / Suppl setp scal		
	Access level: 3	Calculated: -	Data type: U32 / FloatingPoint32
	Can be changed: T	Scaling: PERCENT	Dyn. index: CDS, p0170
	Unit group: -	Unit selection: -	Func. diagram: 3001, 3030
	Min	Max	Factory setting
	-	-	1
Description:	Sets the signal source for scaling the supplementary setpoint.		
r1077	CO: Supplementary setpoint effective / Suppl setpoint eff		
	Access level: 3	Calculated: -	Data type: FloatingPoint32
	Can be changed: -	Scaling: p2000	Dyn. index: -
	Unit group: 3_1	Unit selection: p0505	Func. diagram: 3030
	Min	Max	Factory setting
	- [rpm]	- [rpm]	- [rpm]
Description:	Displays the effective supplementary setpoint. The value shown is the additional setpoint after scaling.		
r1078	CO: Total setpoint effective / Total setpoint eff		
	Access level: 3	Calculated: -	Data type: FloatingPoint32
	Can be changed: -	Scaling: p2000	Dyn. index: -
	Unit group: 3_1	Unit selection: p0505	Func. diagram: 3030
	Min	Max	Factory setting
	- [rpm]	- [rpm]	- [rpm]
Description:	Displays the total effective setpoint. The value indicates the sum of the effective main setpoint and supplementary setpoint.		
p1079	Interpolator clock cycle for speed setpoints / Interp_cyc n_set		
G115D PN	Access level: 3	Calculated: p0340 = 1	Data type: FloatingPoint32
G115D ASI	Can be changed: U, T	Scaling: -	Dyn. index: -
	Unit group: -	Unit selection: -	Func. diagram: -
	Min	Max	Factory setting
	0.00 [ms]	127.00 [ms]	0.00 [ms]
Description:	Sets the time with which new speed setpoints are interpolated. With interpolation, the higher-level control adapts the speed setpoint steps to the time grid of the setpoint channel.		
Recommendation:	For non-synchronous operation, a setting to the maximum time difference between two setpoints is recommended. For sensorless vector control, interpolation should always be activated if the ramp-up and ramp-down times of the ramp-function generator are very short. The drive must be able to follow the external speed setpoint (the drive does not ramp up at the torque limit).		

2 Parameters

2.2 List of parameters

Note: For acceleration precontrol of the speed controller, interpolation prevents torque peaks from occurring if the ramp-up or ramp-down times in the setpoint channel are zero.

When exiting commissioning, the parameter is preset using the automatic calculation if, as setpoint source for the main or supplementary setpoint, a PZD receive word is already set and the ramp-up time is zero.

Interpolation is limited to 127 cycles of the setpoint channel.

p1079 = 0 ms: interpolation is deactivated.

p1079 = 0.01 ms: the interpolation is automatically determined the first time that the speed setpoint is changed. After this, no other changes are made if the send times of the external control increase. Writing to p1079 again initiates the automatic adaptation of the interpolation time.

p1079 > 0.01 ms: interpolation is performed corresponding to the ratio to the computation clock cycle.

p1080[0...n]	Minimum speed / n_min		
	Access level: 1	Calculated: -	Data type: FloatingPoint32
	Can be changed: C(1), T	Scaling: -	Dyn. index: DDS, p0180
	Unit group: 3_1	Unit selection: p0505	Func. diagram: 3050, 8022
	Min	Max	Factory setting
	0.000 [rpm]	19500.000 [rpm]	0.000 [rpm]
Description:	Sets the lowest possible motor speed. This value is not undershot in operation.		
Dependency:	Refer to: p1106		
Notice:	The effective minimum speed is formed from p1080 and p1106.		
Note:	The parameter value applies for both motor directions. In exceptional cases, the motor can operate below this value (e.g. when reversing).		

p1081	Maximum speed scaling / n_max scal		
	Access level: 2	Calculated: -	Data type: FloatingPoint32
	Can be changed: U, T	Scaling: PERCENT	Dyn. index: -
	Unit group: -	Unit selection: -	Func. diagram: 3050, 3095
	Min	Max	Factory setting
	100.00 [%]	105.00 [%]	100.00 [%]
Description:	Sets the scaling for the maximum speed (p1082). For a higher-level speed control, this scaling allows the maximum speed to be briefly exceeded.		
Dependency:	Refer to: p1082		
Notice:	Continuous operation above a scaling of 100 % is not permitted.		

p1082[0...n]	Maximum speed / n_max		
	Access level: 1	Calculated: p0340 = 1	Data type: FloatingPoint32
	Can be changed: C(1), T	Scaling: -	Dyn. index: DDS, p0180
	Unit group: 3_1	Unit selection: p0505	Func. diagram: 3020, 3050, 3060, 3070
	Min	Max	Factory setting
	0.000 [rpm]	210000.000 [rpm]	1500.000 [rpm]
Description:	Sets the highest possible speed. Example: Induction motor p0310 = 50 / 60 Hz without output filter and Blocksize power unit p1082 <= 60 x 240 Hz / r0313 (vector control) p1082 <= 60 x 550 Hz / r0313 (U/f control)		

Dependency:	For vector control, the maximum speed is restricted to $60.0 / (8.333 \times 500 \mu\text{s} \times r0313)$. This can be identified by a reduction in r1084. p1082 is not changed in this process due to the fact that the operating mode p1300 can be changed over. If a sine-wave filter (p0230 = 3) is parameterized as output filter, then the maximum speed is limited corresponding to the maximum permissible filter output frequency (refer to the filter data sheet). When using sine-wave filters (p0230 = 3, 4), the maximum speed r1084 is limited to 70% of the resonant frequency of the filter capacitance and the motor leakage inductance. For reactors and dU/dt filters, it is limited to 120 Hz / r0313. Refer to: r0313, p0322
Notice:	After the value has been modified, no further parameter modifications can be made and the status is shown in r3996. Modifications can be made again when r3996 = 0.
Note:	The parameter applies for both motor directions. The parameter has a limiting effect and is the reference quantity for all ramp-up and ramp-down times (e.g. down ramps, ramp-function generator, motor potentiometer). The parameter is part of the quick commissioning (p0010 = 1); this means that it is appropriately pre-assigned when changing p0310, p0311, p0322. The following limits are always effective for p1082: $p1082 \leq 60 \times \text{minimum} (15 \times r0310, 550 \text{ Hz}) / r0313$ $p1082 \leq 60 \times \text{maximum power unit pulse frequency} / (k \times r0313)$, with $k = 12$ (vector control), $k = 6.5$ (U/f control) During automatic calculation (p0340 = 1, p3900 > 0), the parameter value is assigned the maximum motor speed (p0322). For p0322 = 0 the rated motor speed (p0311) is used as default (pre-assignment) value. For induction motors, the synchronous no-load speed is used as the default value (p0310 x 60 / r0313). For synchronous motors, the following additionally applies: During automatic calculation (p0340, p3900), p1082 is limited to speeds where the EMF does not exceed the DC link voltage. p1082 is also available in the quick commissioning (p0010 = 1); this means that when exiting via p3900 > 0, the value is not changed.

p1083[0...n]	CO: Speed limit in positive direction of rotation / n_limit pos		
Access level: 3	Calculated: -	Data type: FloatingPoint32	
Can be changed: U, T	Scaling: p2000	Dyn. index: DDS, p0180	
Unit group: 3_1	Unit selection: p0505	Func. diagram: 3050	
Min	Max	Factory setting	
0.000 [rpm]	210000.000 [rpm]	210000.000 [rpm]	

Description:	Sets the maximum speed for the positive direction.
Notice:	A BICO interconnection to a parameter that belongs to a drive data set always acts on the effective data set.

r1084	CO: Speed limit positive effective / n_limit pos eff		
Access level: 3	Calculated: -	Data type: FloatingPoint32	
Can be changed: -	Scaling: p2000	Dyn. index: -	
Unit group: 3_1	Unit selection: p0505	Func. diagram: 3050, 7958	
Min	Max	Factory setting	
- [rpm]	- [rpm]	- [rpm]	

Description:	Display and connector output for the active positive speed limit.
Dependency:	Refer to: p1082, p1083, p1085
Note:	Vector control: $r1084 \leq 60 \times 240 \text{ Hz} / r0313$

p1085[0...n]	CI: Speed limit in positive direction of rotation / n_limit pos		
Access level: 3	Calculated: -	Data type: U32 / FloatingPoint32	
Can be changed: T	Scaling: p2000	Dyn. index: CDS, p0170	
Unit group: -	Unit selection: -	Func. diagram: 3050	
Min	Max	Factory setting	
-	-	1083[0]	

Description:	Sets the signal source for the speed limit of the positive direction.
---------------------	-----------------------------------------------------------------------

p1086[0...n]	CO: Speed limit in negative direction of rotation / n_limit neg		
	Access level: 3	Calculated: -	Data type: FloatingPoint32
	Can be changed: U, T	Scaling: p2000	Dyn. index: DDS, p0180
	Unit group: 3_1	Unit selection: p0505	Func. diagram: 3050
	Min	Max	Factory setting
	-210000.000 [rpm]	0.000 [rpm]	-210000.000 [rpm]
Description:	Sets the speed limit for the negative direction.		
Notice:	A BICO interconnection to a parameter that belongs to a drive data set always acts on the effective data set.		
r1087	CO: Speed limit negative effective / n_limit neg eff		
	Access level: 3	Calculated: -	Data type: FloatingPoint32
	Can be changed: -	Scaling: p2000	Dyn. index: -
	Unit group: 3_1	Unit selection: p0505	Func. diagram: 3050, 7958
	Min	Max	Factory setting
	- [rpm]	- [rpm]	- [rpm]
Description:	Display and connector output for the active negative speed limit.		
Dependency:	Refer to: p1082, p1086, p1088		
Note:	Vector control: r1087 >= -60 x 240 Hz / r0313		
p1088[0...n]	CI: Speed limit in negative direction of rotation / n_limit neg		
	Access level: 3	Calculated: -	Data type: U32 / FloatingPoint32
	Can be changed: T	Scaling: p2000	Dyn. index: CDS, p0170
	Unit group: -	Unit selection: -	Func. diagram: 3050
	Min	Max	Factory setting
	-	-	1086[0]
Description:	Sets the signal source for the speed/velocity limit of the negative direction.		
p1091[0...n]	Skip speed 1 / n_skip 1		
	Access level: 3	Calculated: -	Data type: FloatingPoint32
	Can be changed: U, T	Scaling: p2000	Dyn. index: DDS, p0180
	Unit group: 3_1	Unit selection: p0505	Func. diagram: 3050
	Min	Max	Factory setting
	0.000 [rpm]	210000.000 [rpm]	0.000 [rpm]
Description:	Sets skip speed 1.		
Dependency:	Refer to: p1092, p1093, p1094, p1101		
Notice:	Skip bandwidths can also become ineffective as a result of the downstream limits in the setpoint channel.		
Note:	The skip (suppression) speeds can be used to prevent the effects of mechanical resonance.		
p1092[0...n]	Skip speed 2 / n_skip 2		
	Access level: 3	Calculated: -	Data type: FloatingPoint32
	Can be changed: U, T	Scaling: p2000	Dyn. index: DDS, p0180
	Unit group: 3_1	Unit selection: p0505	Func. diagram: 3050
	Min	Max	Factory setting
	0.000 [rpm]	210000.000 [rpm]	0.000 [rpm]
Description:	Sets skip speed 2.		
Dependency:	Refer to: p1091, p1093, p1094, p1101		
Notice:	Skip bandwidths can also become ineffective as a result of the downstream limits in the setpoint channel.		

p1093[0...n]	Skip speed 3 / n_skip 3			
	Access level: 3	Calculated: -	Data type: FloatingPoint32	
	Can be changed: U, T	Scaling: p2000	Dyn. index: DDS, p0180	
	Unit group: 3_1	Unit selection: p0505	Func. diagram: 3050	
	Min	Max	Factory setting	
	0.000 [rpm]	210000.000 [rpm]	0.000 [rpm]	
Description:	Sets skip speed 3.			
Dependency:	Refer to: p1091, p1092, p1094, p1101			
Notice:	Skip bandwidths can also become ineffective as a result of the downstream limits in the setpoint channel.			
p1094[0...n]	Skip speed 4 / n_skip 4			
	Access level: 3	Calculated: -	Data type: FloatingPoint32	
	Can be changed: U, T	Scaling: p2000	Dyn. index: DDS, p0180	
	Unit group: 3_1	Unit selection: p0505	Func. diagram: 3050	
	Min	Max	Factory setting	
	0.000 [rpm]	210000.000 [rpm]	0.000 [rpm]	
Description:	Sets skip speed 4.			
Dependency:	Refer to: p1091, p1092, p1093, p1101			
Notice:	Skip bandwidths can also become ineffective as a result of the downstream limits in the setpoint channel.			
p1098[0...n]	Cl: Skip speed scaling / n_skip scal			
	Access level: 3	Calculated: -	Data type: U32 / FloatingPoint32	
	Can be changed: T	Scaling: PERCENT	Dyn. index: CDS, p0170	
	Unit group: -	Unit selection: -	Func. diagram: 3050	
	Min	Max	Factory setting	
	-	-	1	
Description:	Sets the signal source for scaling the skip speeds.			
Dependency:	Refer to: p1091, p1092, p1093, p1094			
r1099.0	CO/BO: Skip band status word / Skip band ZSW			
	Access level: 3	Calculated: -	Data type: Unsigned32	
	Can be changed: -	Scaling: -	Dyn. index: -	
	Unit group: -	Unit selection: -	Func. diagram: -	
	Min	Max	Factory setting	
	-	-	-	
Description:	Display and BICO output for the skip bands.			
Bit field:	Bit	Signal name	1 signal	0 signal
	00	r1170 within the skip band	Yes	No
Dependency:	Refer to: r1170			
Note:	For bit 00: With the bit set, the setpoint speed is within the skip band after the ramp-function generator (r1170). The signal can be used to switch over the drive data set (DDS).			
p1101[0...n]	Skip speed bandwidth / n_skip bandwidth			
	Access level: 3	Calculated: -	Data type: FloatingPoint32	
	Can be changed: U, T	Scaling: p2000	Dyn. index: DDS, p0180	
	Unit group: 3_1	Unit selection: p0505	Func. diagram: 3050	
	Min	Max	Factory setting	
	0.000 [rpm]	210000.000 [rpm]	0.000 [rpm]	
Description:	Sets the bandwidth for the skip speeds/velocities 1 to 4.			
Dependency:	Refer to: p1091, p1092, p1093, p1094			

Note: The setpoint (reference) speeds are skipped (suppressed) in the range of the skip speed +/-p1101. Steady-state operation is not possible in the skipped (suppressed) speed range. The skip (suppression) range is skipped.
 Example:
 p1091 = 600 and p1101 = 20
 --> setpoint speeds between 580 and 620 [rpm] are skipped.
 For the skip bandwidths, the following hysteresis behavior applies:
 For a setpoint speed coming from below, the following applies:
 r1170 < 580 [rpm] and 580 [rpm] <= r1114 <= 620 [rpm] --> r1119 = 580 [rpm]
 For a setpoint speed coming from above, the following applies:
 r1170 > 620 [rpm] and 580 [rpm] <= r1114 <= 620 [rpm] --> r1119 = 620 [rpm]

p1106[0...n]	CI: Minimum speed signal source / n_min s_s		
	Access level: 3	Calculated: -	Data type: U32 / FloatingPoint32
	Can be changed: T	Scaling: p2000	Dyn. index: CDS, p0170
	Unit group: -	Unit selection: -	Func. diagram: 3050
	Min	Max	Factory setting
	-	-	0
Description:	Sets the signal source for lowest possible motor speed.		
Dependency:	Refer to: p1080		
Notice:	The effective minimum speed is formed from p1080 and p1106.		

p1108[0...n]	BI: Total setpoint selection / Total setp sel		
	Access level: 4	Calculated: -	Data type: U32 / Binary
	Can be changed: T	Scaling: -	Dyn. index: CDS, p0170
	Unit group: -	Unit selection: -	Func. diagram: 3030
	Min	Max	Factory setting
	-	-	0
Description:	Sets the signal source to select the total setpoint.		
Dependency:	The selection of the total speed setpoint is automatically interconnected to the status word of the technology controller (r2349.4) if the technology controller is selected (p2200 > 0) and operated in the mode p2251 = 0. Refer to: p1109		

Caution: If the technology controller is to supply the total setpoint using p1109, then it is not permissible to withdraw the interconnection to its status word (r2349.4).



p1109[0...n]	CI: Total setpoint / Total setp		
	Access level: 4	Calculated: -	Data type: U32 / FloatingPoint32
	Can be changed: T	Scaling: p2000	Dyn. index: CDS, p0170
	Unit group: -	Unit selection: -	Func. diagram: 3030
	Min	Max	Factory setting
	-	-	0

Description: Sets the signal source for the total setpoint.
 For p1108 = 1 signal, the total setpoint is read in via p1109.

Dependency: The signal source of the total setpoint is automatically interconnected to the output of the technology controller (r2294) if the technology controller is selected (p2200 > 0) and operated in the mode p2251 = 0. Refer to: p1108

Caution: If the technology controller is to supply the total setpoint using p1109, then it is not permissible to disable the interconnection to its output (r2294).



p1110[0...n]	Bl: Inhibit negative direction / Inhib neg dir		
	Access level: 3	Calculated: -	Data type: U32 / Binary
	Can be changed: T	Scaling: -	Dyn. index: CDS, p0170
	Unit group: -	Unit selection: -	Func. diagram: 2505, 3040
	Min	Max	Factory setting
	-	-	0
Description:	Sets the signal source to disable the negative direction.		
Dependency:	Refer to: p1111		
p1111[0...n]	Bl: Inhibit positive direction / Inhib pos dir		
	Access level: 3	Calculated: -	Data type: U32 / Binary
	Can be changed: T	Scaling: -	Dyn. index: CDS, p0170
	Unit group: -	Unit selection: -	Func. diagram: 2505, 3040
	Min	Max	Factory setting
	-	-	0
Description:	Sets the signal source to disable the positive direction.		
Dependency:	Refer to: p1110		
r1112	CO: Speed setpoint after minimum limiting / n_set aft min_lim		
	Access level: 4	Calculated: -	Data type: FloatingPoint32
	Can be changed: -	Scaling: p2000	Dyn. index: -
	Unit group: 3_1	Unit selection: p0505	Func. diagram: 3050
	Min	Max	Factory setting
	- [rpm]	- [rpm]	- [rpm]
Description:	Displays the speed setpoint after the minimum limiting.		
Dependency:	Refer to: p1091, p1092, p1093, p1094, p1101		
p1113[0...n]	Bl: Setpoint inversion / Setp inv		
G115D ASI	Access level: 3	Calculated: -	Data type: U32 / Binary
	Can be changed: T	Scaling: -	Dyn. index: CDS, p0170
	Unit group: -	Unit selection: -	Func. diagram: 2441, 2442, 2505, 3040
	Min	Max	Factory setting
	-	-	0
Description:	Sets the signal source to invert the setpoint.		
Dependency:	Refer to: r1198		
Caution:	If the technology controller is being used as the speed main setpoint (p2251 = 0), do not invert the setpoint using p1113 when the technology controller is enabled because this can cause the speed to change suddenly and lead to positive couplings in the control loop.		
			
Notice:	The parameter may be protected as a result of p0922 or p2079 and cannot be changed.		
p1113[0...n]	Bl: Setpoint inversion / Setp inv		
G115D I/O	Access level: 3	Calculated: -	Data type: U32 / Binary
	Can be changed: T	Scaling: -	Dyn. index: CDS, p0170
	Unit group: -	Unit selection: -	Func. diagram: 2441, 2442, 2505, 3040
	Min	Max	Factory setting
	-	-	[0] 3333.1 [1] 3333.1 [2] 0 [3] 0
Description:	Sets the signal source to invert the setpoint.		
Dependency:	Refer to: r1198		

Caution:  If the technology controller is being used as the speed main setpoint (p2251 = 0), do not invert the setpoint using p1113 when the technology controller is enabled because this can cause the speed to change suddenly and lead to positive couplings in the control loop.

Notice: The parameter may be protected as a result of p0922 or p2079 and cannot be changed.

p1113[0...n]	BI: Setpoint inversion / Setp inv		
G115D PN	Access level: 3	Calculated: -	Data type: U32 / Binary
	Can be changed: T	Scaling: -	Dyn. index: CDS, p0170
	Unit group: -	Unit selection: -	Func. diagram: 2441, 2442, 2505, 3040
	Min	Max	Factory setting
	-	-	[0] 2090.11
			[1] 0
			[2] 0
			[3] 0

Description: Sets the signal source to invert the setpoint.

Dependency: Refer to: r1198

Caution:  If the technology controller is being used as the speed main setpoint (p2251 = 0), do not invert the setpoint using p1113 when the technology controller is enabled because this can cause the speed to change suddenly and lead to positive couplings in the control loop.

Notice: The parameter may be protected as a result of p0922 or p2079 and cannot be changed.

r1114	CO: Setpoint after the direction limiting / Setp after limit		
	Access level: 3	Calculated: -	Data type: FloatingPoint32
	Can be changed: -	Scaling: p2000	Dyn. index: -
	Unit group: 3_1	Unit selection: p0505	Func. diagram: 3001, 3040, 3050
	Min	Max	Factory setting
	- [rpm]	- [rpm]	- [rpm]

Description: Displays the speed/velocity setpoint after the changeover and limiting the direction.

p1115	Ramp-function generator selection / RFG selection		
	Access level: 3	Calculated: -	Data type: Integer16
	Can be changed: T	Scaling: -	Dyn. index: -
	Unit group: -	Unit selection: -	Func. diagram: 3001, 3080
	Min	Max	Factory setting
	0	1	1

Description: Sets the ramp-function generator type.

Value: 0: Basic ramp-function generator
1: Extended ramp-function generator

Note: Another ramp-function generator type can only be selected when the motor is at a standstill.

r1119	CO: Ramp-function generator setpoint at the input / RFG setp at inp		
	Access level: 3	Calculated: -	Data type: FloatingPoint32
	Can be changed: -	Scaling: p2000	Dyn. index: -
	Unit group: 3_1	Unit selection: p0505	Func. diagram: 3050, 3070, 6300, 8022
	Min	Max	Factory setting
	- [rpm]	- [rpm]	- [rpm]

Description: Displays the setpoint at the input of the ramp-function generator.

Notice: The parameter may be protected as a result of p0922 or p2079 and cannot be changed.

Note: The setpoint is influenced by other functions, e.g. skip (suppressed) speeds, minimum and maximum limits.

p1120[0...n]	Ramp-function generator ramp-up time / RFG ramp-up time		
	Access level: 1	Calculated: -	Data type: FloatingPoint32
	Can be changed: C(1), U, T	Scaling: -	Dyn. index: DDS, p0180
	Unit group: -	Unit selection: -	Func. diagram: 3060, 3070
	Min	Max	Factory setting
	0.000 [s]	999999.000 [s]	1.000 [s]
Description:	The ramp-function generator ramps-up the speed setpoint from standstill (setpoint = 0) up to the maximum speed (p1082) in this time.		
Dependency:	Refer to: p1082, p1123		
Note:	The ramp-up time can be scaled via connector input p1138. The parameter is adapted during the rotating measurement (p1960 > 0). This is the reason that during the rotating measurement, the motor can accelerate faster than was originally parameterized. For U/f control and sensorless vector control (see p1300), a ramp-up time of 0 s does not make sense. The setting should be based on the startup times (r0345) of the motor.		
p1121[0...n]	Ramp-function generator ramp-down time / RFG ramp-down time		
	Access level: 1	Calculated: -	Data type: FloatingPoint32
	Can be changed: C(1), U, T	Scaling: -	Dyn. index: DDS, p0180
	Unit group: -	Unit selection: -	Func. diagram: 3060, 3070
	Min	Max	Factory setting
	0.000 [s]	999999.000 [s]	1.000 [s]
Description:	Sets the ramp-down time for the ramp-function generator. The ramp-function generator ramps-down the speed setpoint from the maximum speed (p1082) down to standstill (setpoint = 0) in this time. Further, the ramp-down time is always effective for OFF1.		
Dependency:	Refer to: p1082, p1123		
Note:	For U/f control and sensorless vector control (see p1300), a ramp-down time of 0 s does not make sense. The setting should be based on the startup times (r0345) of the motor.		
p1122[0...n]	Bl: Bypass ramp-function generator / Bypass RFG		
	Access level: 4	Calculated: -	Data type: U32 / Binary
	Can be changed: U, T	Scaling: -	Dyn. index: CDS, p0170
	Unit group: -	Unit selection: -	Func. diagram: 2505
	Min	Max	Factory setting
	-	-	0
Description:	Sets the signal source for bypassing the ramp generator (ramp-up and ramp-down times = 0).		
Caution:	If the technology controller is operated in mode p2251 = 0 (technology controller as main speed setpoint), then it is not permissible to disable the interconnection to its status word (r2349).		
			
Notice:	The parameter may be protected as a result of p0922 or p2079 and cannot be changed.		
Note:	In the case of sensorless vector control, the ramp-function generator must not be bypassed, other than indirectly by means of interconnection with r2349.		
p1123[0...n]	Ramp-function generator minimum ramp-up time / RFG t_RU min		
	Access level: 4	Calculated: p0340 = 1	Data type: FloatingPoint32
	Can be changed: U, T	Scaling: -	Dyn. index: DDS, p0180
	Unit group: -	Unit selection: -	Func. diagram: -
	Min	Max	Factory setting
	0.000 [s]	999999.000 [s]	0.000 [s]
Description:	Sets the minimum ramp-up time. The ramp-up time (p1120) is limited internally to this minimum value.		
Dependency:	Refer to: p1082		
Note:	The setting should be based on the startup times (r0345) of the motor. If the maximum speed p1082 changes, p1123 is re-calculated.		

p1127[0...n]	Ramp-function generator minimum ramp-down time / RFG t_{RD} min		
	Access level: 3	Calculated: p0340 = 1	Data type: FloatingPoint32
	Can be changed: U, T	Scaling: -	Dyn. index: DDS, p0180
	Unit group: -	Unit selection: -	Func. diagram: -
	Min	Max	Factory setting
	0.000 [s]	999999.000 [s]	0.000 [s]
Description:	Sets the minimum ramp-down time. The ramp-down time (p1121) is limited internally to this minimum value. The parameter cannot be set shorter than the minimum ramp-up time (p1123).		
Dependency:	Refer to: p1082		
Note:	For U/f control and sensorless vector control (see p1300), a ramp-down time of 0 s does not make sense. The setting should be based on the startup times (r0345) of the motor. If the maximum speed p1082 changes, p1127 is re-calculated. If a braking resistor is connected to the DC link (p0219 > 0), then the minimum ramp-down time is automatically adapted using p1127.		
p1130[0...n]	Ramp-function generator initial rounding-off time / RFG t_{start_round}		
	Access level: 2	Calculated: -	Data type: FloatingPoint32
	Can be changed: U, T	Scaling: -	Dyn. index: DDS, p0180
	Unit group: -	Unit selection: -	Func. diagram: 3070
	Min	Max	Factory setting
	0.000 [s]	30.000 [s]	0.000 [s]
Description:	Sets the initial rounding-off time for the extended ramp generator. The value applies to ramp-up and ramp-down.		
Note:	Rounding-off times avoid an abrupt response and prevent damage to the mechanical system. Rounding off is not active if the technology controller is used as main speed setpoint (p2251 = 0).		
p1131[0...n]	Ramp-function generator final rounding-off time / RFG t_{end_delay}		
	Access level: 2	Calculated: -	Data type: FloatingPoint32
	Can be changed: U, T	Scaling: -	Dyn. index: DDS, p0180
	Unit group: -	Unit selection: -	Func. diagram: 3070
	Min	Max	Factory setting
	0.000 [s]	30.000 [s]	0.000 [s]
Description:	Sets the final rounding-off time for the extended ramp generator. The value applies to ramp-up and ramp-down.		
Note:	Rounding-off times avoid an abrupt response and prevent damage to the mechanical system. Rounding off is not active if the technology controller is used as main speed setpoint (p2251 = 0).		
p1134[0...n]	Ramp-function generator rounding-off type / RFG round-off type		
	Access level: 2	Calculated: -	Data type: Integer16
	Can be changed: U, T	Scaling: -	Dyn. index: DDS, p0180
	Unit group: -	Unit selection: -	Func. diagram: 3070
	Min	Max	Factory setting
	0	1	0
Description:	Sets the smoothed response to the OFF1 command or the reduced setpoint for the extended ramp-function generator.		
Value:	0: Continuous smoothing 1: Discontinuous smoothing		
Dependency:	No effect up to initial rounding-off time (p1130) > 0 s.		

Note: p1134 = 0 (continuous smoothing)
 If the setpoint is reduced while ramping-up, initially a final rounding-off is carried out and then the ramp-up completed. During the final rounding-off, the output of the ramp-function generator continues to go in the direction of the previous setpoint (overshoot). After the final rounding-off has been completed, the output goes toward the new setpoint.

p1134 = 1 (discontinuous smoothing)
 If the setpoint is reduced while ramping-up, then the output goes immediately in the direction of the new setpoint. For the setpoint change there is no rounding-off.

p1135[0...n]	OFF3 ramp-down time / OFF3 t_RD		
Access level: 2	Calculated: -	Data type: FloatingPoint32	
Can be changed: C(1), U, T	Scaling: -	Dyn. index: DDS, p0180	
Unit group: -	Unit selection: -	Func. diagram: 3060, 3070	
Min	Max	Factory setting	
0.000 [s]	5400.000 [s]	0.000 [s]	

Description: Sets the ramp-down time from the maximum speed down to zero speed for the OFF3 command.

Note: This time can be exceeded if the DC link voltage reaches its maximum value.

p1136[0...n]	OFF3 initial rounding-off time / RFGOFF3 t_strt_rnd		
Access level: 3	Calculated: -	Data type: FloatingPoint32	
Can be changed: U, T	Scaling: -	Dyn. index: DDS, p0180	
Unit group: -	Unit selection: -	Func. diagram: 3070	
Min	Max	Factory setting	
0.000 [s]	30.000 [s]	0.000 [s]	

Description: Sets the initial rounding-off time for OFF3 for the extended ramp generator.

p1137[0...n]	OFF3 final rounding-off time / RFG OFF3 t_end_del		
Access level: 3	Calculated: -	Data type: FloatingPoint32	
Can be changed: U, T	Scaling: -	Dyn. index: DDS, p0180	
Unit group: -	Unit selection: -	Func. diagram: 3070	
Min	Max	Factory setting	
0.000 [s]	30.000 [s]	0.000 [s]	

Description: Sets the final rounding-off time for OFF3 for the extended ramp generator.

p1138[0...n]	CI: Ramp-function generator ramp-up time scaling / RFG t_RU scal		
Access level: 3	Calculated: -	Data type: U32 / FloatingPoint32	
Can be changed: T	Scaling: PERCENT	Dyn. index: CDS, p0170	
Unit group: -	Unit selection: -	Func. diagram: 3060, 3070	
Min	Max	Factory setting	
-	-	1	

Description: Sets the signal source for scaling the ramp-up time of the ramp-function generator.

Dependency: Refer to: p1120



Note: The ramp-up time is set in p1120.

p1139[0...n]	CI: Ramp-function generator ramp-down time scaling / RFG t_RD scal		
Access level: 3	Calculated: -	Data type: U32 / FloatingPoint32	
Can be changed: T	Scaling: PERCENT	Dyn. index: CDS, p0170	
Unit group: -	Unit selection: -	Func. diagram: 3060, 3070	
Min	Max	Factory setting	
-	-	1	

Description: Sets the signal source for scaling the ramp-down time of the ramp-function generator.

Dependency: Refer to: p1121

Note: The ramp-down time is set in p1121.

p1140[0...n]	BI: Enable ramp-function generator/inhibit ramp-function generator / Enable RFG		
G115D I/O	Access level: 3	Calculated: -	Data type: U32 / Binary
G115D ASI	Can be changed: T	Scaling: -	Dyn. index: CDS, p0170
	Unit group: -	Unit selection: -	Func. diagram: 2501
	Min	Max	Factory setting
	-	-	1
Description:	Sets the signal source for the command "enable ramp-function generator/inhibit ramp-function generator". For the PROFIdrive profile, this command corresponds to control word 1 bit 4 (STW1.4). BI: p1140 = 0 signal: Inhibits the ramp-function generator (the ramp-function generator output is set to zero). BI: p1140 = 1 signal: Enable ramp-function generator.		
Dependency:	Refer to: r0054, p1141, p1142		
Caution:	When "master control from PC" is activated, this binector input is ineffective.		
			
Notice:	The parameter may be protected as a result of p0922 or p2079 and cannot be changed.		
p1140[0...n]	BI: Enable ramp-function generator/inhibit ramp-function generator / Enable RFG		
G115D PN	Access level: 3	Calculated: -	Data type: U32 / Binary
	Can be changed: T	Scaling: -	Dyn. index: CDS, p0170
	Unit group: -	Unit selection: -	Func. diagram: 2501
	Min	Max	Factory setting
	-	-	[0] 2090.4
			[1] 1
			[2] 2090.4
			[3] 2090.4
Description:	Sets the signal source for the command "enable ramp-function generator/inhibit ramp-function generator". For the PROFIdrive profile, this command corresponds to control word 1 bit 4 (STW1.4). BI: p1140 = 0 signal: Inhibits the ramp-function generator (the ramp-function generator output is set to zero). BI: p1140 = 1 signal: Enable ramp-function generator.		
Dependency:	Refer to: r0054, p1141, p1142		
Caution:	When "master control from PC" is activated, this binector input is ineffective.		
			
Notice:	The parameter may be protected as a result of p0922 or p2079 and cannot be changed.		
p1141[0...n]	BI: Continue ramp-function generator/freeze ramp-function generator / Continue RFG		
G115D I/O	Access level: 3	Calculated: -	Data type: U32 / Binary
G115D ASI	Can be changed: T	Scaling: -	Dyn. index: CDS, p0170
	Unit group: -	Unit selection: -	Func. diagram: 2501
	Min	Max	Factory setting
	-	-	1
Description:	Sets the signal source for the command "continue ramp-function generator/freeze ramp-function generator". For the PROFIdrive profile, this command corresponds to control word 1 bit 5 (STW1.5). BI: p1141 = 0 signal: Freezes the ramp-function generator. BI: p1141 = 1 signal: Continue ramp-function generator.		
Dependency:	Refer to: r0054, p1140, p1142		

Caution: When "master control from PC" is activated, this binector input is ineffective.



Notice: The ramp-function generator is, independent of the state of the signal source, active in the following cases:

- OFF1/OFF3.
- ramp-function generator output within the suppression bandwidth.
- ramp-function generator output below the minimum speed.

p1141[0...n] **BI: Continue ramp-function generator/freeze ramp-function generator / Continue RFG**

G115D PN	Access level: 3	Calculated: -	Data type: U32 / Binary
	Can be changed: T	Scaling: -	Dyn. index: CDS, p0170
	Unit group: -	Unit selection: -	Func. diagram: 2501
	Min	Max	Factory setting
	-	-	[0] 2090.5
			[1] 1
			[2] 2090.5
			[3] 2090.5

Description: Sets the signal source for the command "continue ramp-function generator/freeze ramp-function generator". For the PROFIdrive profile, this command corresponds to control word 1 bit 5 (STW1.5).

BI: p1141 = 0 signal:
Freezes the ramp-function generator.
BI: p1141 = 1 signal:
Continue ramp-function generator.

Dependency: Refer to: r0054, p1140, p1142

Caution: When "master control from PC" is activated, this binector input is ineffective.



Notice: The ramp-function generator is, independent of the state of the signal source, active in the following cases:

- OFF1/OFF3.
- ramp-function generator output within the suppression bandwidth.
- ramp-function generator output below the minimum speed.

p1142[0...n] **BI: Enable setpoint/inhibit setpoint / Setpoint enable**

G115D I/O	Access level: 3	Calculated: -	Data type: U32 / Binary
G115D ASI	Can be changed: T	Scaling: -	Dyn. index: CDS, p0170
	Unit group: -	Unit selection: -	Func. diagram: 2501
	Min	Max	Factory setting
	-	-	1

Description: Sets the signal source for the command "enable setpoint/inhibit setpoint". For the PROFIdrive profile, this command corresponds to control word 1 bit 6 (STW1.6).

BI: p1142 = 0 signal
Inhibits the setpoint (the ramp-function generator input is set to zero).
BI: p1142 = 1 signal
Setpoint enable.

Dependency: Refer to: p1140, p1141

Caution: When "master control from PC" is activated, this binector input is ineffective.



Notice: The parameter may be protected as a result of p0922 or p2079 and cannot be changed.

Note: When the function module "position control" (r0108.3 = 1) is activated, this binector input is interconnected as follows as standard:

BI: p1142 = 0 signal

p1142[0...n]	BI: Enable setpoint/inhibit setpoint / Setpoint enable		
G115D PN	Access level: 3	Calculated: -	Data type: U32 / Binary
	Can be changed: T	Scaling: -	Dyn. index: CDS, p0170
	Unit group: -	Unit selection: -	Func. diagram: 2501
	Min	Max	Factory setting
	-	-	[0] 2090.6
			[1] 1
			[2] 2090.6
			[3] 2090.6
Description:	Sets the signal source for the command "enable setpoint/inhibit setpoint". For the PROFIdrive profile, this command corresponds to control word 1 bit 6 (STW1.6). BI: p1142 = 0 signal Inhibits the setpoint (the ramp-function generator input is set to zero). BI: p1142 = 1 signal Setpoint enable.		
Dependency:	Refer to: p1140, p1141		
Caution:	When "master control from PC" is activated, this binector input is ineffective.		
			
Notice:	The parameter may be protected as a result of p0922 or p2079 and cannot be changed.		
Note:	When the function module "position control" (r0108.3 = 1) is activated, this binector input is interconnected as follows as standard: BI: p1142 = 0 signal		
p1143[0...n]	BI: Ramp-function generator, accept setting value / RFG accept set v		
	Access level: 3	Calculated: -	Data type: U32 / Binary
	Can be changed: T	Scaling: -	Dyn. index: CDS, p0170
	Unit group: -	Unit selection: -	Func. diagram: 3060, 3070
	Min	Max	Factory setting
	-	-	0
Description:	Sets the signal source for accepting the setting value of the ramp-function generator.		
Dependency:	The signal source for the ramp-function generator setting value is set using parameters. Refer to: p1144		
Note:	0/1 signal: The ramp-function generator output is immediately (without delay) set to the setting value of the ramp-function generator. 1 signal: The setting value of the ramp-function generator is effective. 1/0 signal: The input value of the ramp-function generator is effective. The ramp-function generator output is adapted to the input value using the ramp-up time or the ramp-down time. 0 signal: The input value of the ramp-function generator is effective.		
p1144[0...n]	CI: Ramp-function generator setting value / RFG setting value		
	Access level: 3	Calculated: -	Data type: U32 / FloatingPoint32
	Can be changed: U, T	Scaling: p2000	Dyn. index: CDS, p0170
	Unit group: -	Unit selection: -	Func. diagram: 3060, 3070
	Min	Max	Factory setting
	-	-	0
Description:	Sets the signal source for the ramp-function generator setting value.		
Dependency:	The signal source for accepting the setting value is set using parameters. Refer to: p1143		

p1145[0...n]	Ramp-function generator tracking intensity. / RFG track intens		
	Access level: 4	Calculated: -	Data type: FloatingPoint32
	Can be changed: U, T	Scaling: -	Dyn. index: DDS, p0180
	Unit group: -	Unit selection: -	Func. diagram: 3080
	Min	Max	Factory setting
	0.0	50.0	0.0
Description:	Sets the ramp-function generator tracking. The output value of the ramp-function generator is tracked (corrected) corresponding to the maximum possible drive acceleration. The reference value is the deviation at the speed controller/velocity controller input that is necessary to ensure that the motor accelerates at the torque/force limit.		
Recommendation:	If at least one speed setpoint filter/velocity setpoint filter is activated (p1414), then the ramp-function generator tracking should be deactivated (p1145 = 0.0). When the speed setpoint filter is activated, the output value of the ramp-function generator can no longer be tracked (corrected) corresponding to the maximum possible drive acceleration. For p1145 = 0.0: This value deactivates the ramp-function generator tracking. For p1145 = 0.0 ... 1.0: Generally, these values are not practical. They cause the motor to accelerate below its torque limit. The lower the selected value, the greater the margin between the controller and torque limit when accelerating. For p1145 > 1.0: The greater the value, the higher the permissible deviation between the speed setpoint and speed actual value.		
Notice:	If ramp-function generator tracking is activated and the ramp time is set too short, this can cause unsteady acceleration. Remedy: - deactivate ramp-function generator tracking (p1145 = 0). - increase the ramp-up/ramp-down time (p1120, p1121).		
Note:	In the U/f mode, ramp-function generator tracking is not active. The speed difference is reduced if the integral component of the speed controller is not maintained when the torque limit is reached (p1400.16 = 1).		
p1148[0...n]	Ramp-function gen. tolerance for ramp-up and ramp-down active / RFG tol RU/RD act		
	Access level: 3	Calculated: -	Data type: FloatingPoint32
	Can be changed: U, T	Scaling: -	Dyn. index: DDS, p0180
	Unit group: 3_1	Unit selection: p0505	Func. diagram: 3060, 3070
	Min	Max	Factory setting
	0.000 [rpm]	1000.000 [rpm]	19.800 [rpm]
Description:	Sets the tolerance value for the status of the ramp-function generator (ramp-up active, ramp-down active). If the input of the ramp-function generator does not change in comparison to the output by more than the entered tolerance time, then the status bits "ramp-up active" and "ramp-down active" are not influenced.		
Dependency:	Refer to: r1199		
r1149	CO: Ramp-function generator acceleration / RFG acceleration		
	Access level: 3	Calculated: -	Data type: FloatingPoint32
	Can be changed: -	Scaling: p2007	Dyn. index: -
	Unit group: 39_1	Unit selection: p0505	Func. diagram: 3060, 3070
	Min	Max	Factory setting
	- [rev/s ²]	- [rev/s ²]	- [rev/s ²]
Description:	Displays the acceleration of the ramp-function generator.		
Dependency:	Refer to: p1145		

r1150	CO: Ramp-function generator speed setpoint at the output / RFG n_set at outp		
	Access level: 4	Calculated: -	Data type: FloatingPoint32
	Can be changed: -	Scaling: p2000	Dyn. index: -
	Unit group: 3_1	Unit selection: p0505	Func. diagram: 3001, 3080
	Min	Max	Factory setting
	- [rpm]	- [rpm]	- [rpm]
Description:	Displays the setpoint at the output of the ramp-function generator.		
p1155[0...n]	CI: Speed controller speed setpoint 1 / n_ctrl n_set 1		
	Access level: 4	Calculated: -	Data type: U32 / FloatingPoint32
	Can be changed: T	Scaling: p2000	Dyn. index: CDS, p0170
	Unit group: -	Unit selection: -	Func. diagram: 3001, 3080, 5030, 6031
	Min	Max	Factory setting
	-	-	0
Description:	Sets the signal source for speed setpoint 1 of the speed controller.		
Dependency:	The effectiveness of this setpoint depends on, e.g. STW1.4 and STW1.6. The signal source of the total setpoint is automatically interconnected to the output of the technology controller (r2294) if the technology controller is selected (p2200 > 0) and operated in the mode p2251 = 1. Refer to: r0002, p0840, p0844, p0848, p0852, p0854, r0898, p1140, p1142, p1160, r1170		
Caution:	If the technology controller is activated, then it is not permissible to withdraw the parameter interconnection.		
			
Notice:	The parameter may be protected as a result of p0922 or p2079 and cannot be changed.		
p1160[0...n]	CI: Speed controller speed setpoint 2 / n_ctrl n_set 2		
	Access level: 4	Calculated: -	Data type: U32 / FloatingPoint32
	Can be changed: T	Scaling: p2000	Dyn. index: CDS, p0170
	Unit group: -	Unit selection: -	Func. diagram: 3001, 3080
	Min	Max	Factory setting
	-	-	0
Description:	Sets the signal source for speed setpoint 2 of the speed controller.		
Dependency:	Refer to: p1155, r1170		
Note:	For OFF1/OFF3, the ramp-function generator ramp is effective. The ramp-function generator is set (to the setpoint (r1170)) and stops the drive corresponding to the ramp-down time (p1121 or p1135). While stopping via the ramp-function generator, STW1.4 is effective (enable ramp-function generator).		
r1169	CO: Speed controller speed setpoints 1 and 2 / n_ctrl n_set 1/2		
	Access level: 4	Calculated: -	Data type: FloatingPoint32
	Can be changed: -	Scaling: p2000	Dyn. index: -
	Unit group: 3_1	Unit selection: p0505	Func. diagram: 3080
	Min	Max	Factory setting
	- [rpm]	- [rpm]	- [rpm]
Description:	Displays the speed setpoint after the addition of the speed setpoint 1 (p1155) and speed setpoint 2 (p1160).		
Dependency:	Refer to: p1155, p1160		
Note:	The value is only correctly displayed at r0899.2 = 1 (operation enabled).		

r1170	CO: Speed controller setpoint sum / Speed setpoint sum		
	Access level: 3	Calculated: -	Data type: FloatingPoint32
	Can be changed: -	Scaling: p2000	Dyn. index: -
	Unit group: 3_1	Unit selection: p0505	Func. diagram: 3001, 3080, 6300
	Min	Max	Factory setting
	- [rpm]	- [rpm]	- [rpm]
Description:	Display and connector output for the speed setpoint after selecting the ramp-function generator. The value is the sum of speed setpoint 1 (p1155) and speed setpoint 2 (p1160).		
Dependency:	Refer to: r1150, p1155, p1160		

r1197	Fixed speed setpoint number actual / n_set_fixed No act		
	Access level: 4	Calculated: -	Data type: Unsigned32
	Can be changed: -	Scaling: -	Dyn. index: -
	Unit group: -	Unit selection: -	Func. diagram: 3010
	Min	Max	Factory setting
	-	-	-
Description:	Displays the number of the selected fixed speed/velocity setpoint.		
Dependency:	Refer to: p1020, p1021, p1022, p1023		
Note:	If a fixed speed setpoint has not been selected (p1020 ... p1023 = 0, r1197 = 0), then r1024 = 0 (setpoint = 0).		

r1198.0...15	CO/BO: Control word setpoint channel / STW setpoint chan				
	Access level: 3	Calculated: -	Data type: Unsigned16		
	Can be changed: -	Scaling: -	Dyn. index: -		
	Unit group: -	Unit selection: -	Func. diagram: 2505		
	Min	Max	Factory setting		
	-	-	-		
Description:	Display and BICO output for the control word of the setpoint channel.				
Bit field:	Bit	Signal name	1 signal	0 signal	FP
	00	Fixed setpoint bit 0	Yes	No	3010
	01	Fixed setpoint bit 1	Yes	No	3010
	02	Fixed setpoint bit 2	Yes	No	3010
	03	Fixed setpoint bit 3	Yes	No	3010
	05	Inhibit negative direction	Yes	No	3040
	06	Inhibit positive direction	Yes	No	3040
	11	Setpoint inversion	Yes	No	3040
	13	Motorized potentiometer raise	Yes	No	3020
	14	Motorized potentiometer lower	Yes	No	3020
	15	Bypass ramp-function generator	Yes	No	3060, 3070

r1199.0...8	CO/BO: Ramp-function generator status word / RFG ZSW		
	Access level: 4	Calculated: -	Data type: Unsigned16
	Can be changed: -	Scaling: -	Dyn. index: -
	Unit group: -	Unit selection: -	Func. diagram: 3001, 3080
	Min	Max	Factory setting
	-	-	-
Description:	Displays the status word for the ramp-function generator (RFG).		

2 Parameters

2.2 List of parameters

Bit field:	Bit	Signal name	1 signal	0 signal	FP
	00	Ramp-up active	Yes	No	-
	01	Ramp-down active	Yes	No	-
	02	RFG active	Yes	No	-
	03	Ramp-function generator set	Yes	No	-
	04	Ramp-function generator held	Yes	No	-
	05	Ramp-function generator tracking active	Yes	No	-
	06	Maximum limit active	Yes	No	-
	07	Ramp-function generator acceleration positive	Yes	No	-
	08	Ramp-function generator acceleration negative	Yes	No	-

Note: For bit 02:
The bit is the result of the OR logic operation - bit 00 and bit 01.

p1200[0...n]	Flying restart operating mode / FlyRest op_mode
	<p>Access level: 2 Calculated: - Data type: Integer16</p> <p>Can be changed: U, T Scaling: - Dyn. index: DDS, p0180</p> <p>Unit group: - Unit selection: - Func. diagram: 6300</p> <p>Min Max Factory setting</p> <p>0 4 0</p>
Description:	<p>Sets the operating mode for flying restart.</p> <p>The flying restart allows the drive converter to be switched on while the motor is still rotating. In so doing, the drive converter output frequency is changed until the actual motor speed/velocity is found. The motor then accelerates up to the setpoint at the ramp-function generator setting.</p>
Value:	<p>0: Flying restart inactive</p> <p>1: Flying restart always active (start in setpoint direction)</p> <p>4: Flying restart always active (start only in setpoint direction)</p>
Dependency:	<p>A differentiation is made between flying restart for U/f control and for vector control (p1300).</p> <p>Flying restart, U/f control: p1202, p1203, r1204</p> <p>Flying restart, vector control: p1202, p1203, r1205</p> <p>For synchronous motors, flying restart cannot be activated.</p> <p>Refer to: p1201</p> <p>Refer to: F07330, F07331</p>
Notice:	<p>The "flying restart" function must be used in cases where the motor may still be running (e.g. after a brief line supply interruption) or is being driven by the load. The system might otherwise shut down as a result of overcurrent.</p>
Note:	<p>For p1200 = 1, 4, the following applies: Flying restart is active after faults, OFF1, OFF2, OFF3.</p> <p>For p1200 = 1, the following applies: The search is made in both directions.</p> <p>For p1200 = 4, the following applies: The search is only made in the setpoint direction.</p> <p>For U/f control (p1300 < 20), the following applies: The speed can only be sensed for values above approx. 5 % of the rated motor speed. For lower speeds, it is assumed that the motor is at a standstill.</p> <p>If p1200 is changed during commissioning (p0010 > 0), then it is possible that the old value will no longer be able to be set. The reason for this is that the dynamic limits of p1200 have been changed by a parameter that was set when the drive was commissioned (e.g. p0300).</p>

p1201[0...n]	BI: Flying restart enable signal source / Fly_res enab s_s
	<p>Access level: 3 Calculated: - Data type: U32 / Binary</p> <p>Can be changed: T Scaling: - Dyn. index: CDS, p0170</p> <p>Unit group: - Unit selection: - Func. diagram: -</p> <p>Min Max Factory setting</p> <p>- - 1</p>
Description:	<p>Sets the signal source to enable the "flying restart" function.</p>
Dependency:	<p>Refer to: p1200</p>

Note: Withdrawing the enable signal has the same effect as setting p1200 = 0.

p1202[0...n]	Flying restart search current / FlyRest I_srch		
	Access level: 3	Calculated: -	Data type: FloatingPoint32
	Can be changed: U, T	Scaling: -	Dyn. index: DDS, p0180
	Unit group: -	Unit selection: -	Func. diagram: -
	Min	Max	Factory setting
	10 [%]	400 [%]	100 [%]
Description:	Sets the search current for the "flying restart" function. The value is referred to the motor magnetizing current.		
Dependency:	Refer to: r0331		
Caution:	An unfavorable parameter value can result in the motor behaving in an uncontrollable fashion.		
			
Notice:	The following applies for a synchronous reluctance motor: The minimum search current is limited (p1202 >= 50 %).		
Note:	In U/f control mode, the parameter serves as a threshold value for establishing the current at the beginning of the flying restart function. When the threshold value is reached, the actual search current is set as a function of the frequency based on the voltage setpoints. Reducing the search current can also improve flying restart performance (if the system moment of inertia is not very high, for example). The following applies for a synchronous reluctance motor: Adjusting the search current only has an effect if a motor data identification run is then performed (see p1909 bit 22). It is possible that a value exceeding 100% cannot be reached if the motor rated power is significantly less than that of the power unit. If the motor rated power is significantly higher than that of the power unit, then the search current should be increased for the higher speed range.		

p1203[0...n]	Flying restart search rate factor / FlyRst v_Srch Fact		
	Access level: 3	Calculated: -	Data type: FloatingPoint32
	Can be changed: U, T	Scaling: -	Dyn. index: DDS, p0180
	Unit group: -	Unit selection: -	Func. diagram: -
	Min	Max	Factory setting
	10 [%]	4000 [%]	100 [%]
Description:	Sets the factor for the search speed for flying restart. The value influences the rate at which the output frequency is changed during a flying restart. A higher value results in a longer search time.		
Recommendation:	For sensorless vector control and motor cables longer than 200 m, set the factor p1203 >= 300 %.		
Caution:	An unfavorable parameter value can result in the motor behaving in an uncontrollable fashion.		
	For vector control, a value that is too low or too high can cause flying restart to become unstable.		
Note:	The parameter factory setting is selected so that standard induction motors that are rotating can be found and restarted as quickly as possible (fast flying restart). With this pre-setting, if the motor is not found (e.g. for motors that are accelerated as a result of active loads or with U/f control and low speeds), we recommend that the search rate is reduced (by increasing p1203). For the flying restart of a reluctance motor, the minimum search velocity is limited (p1203 >= 50 %).		

r1204.0...13	CO/BO: Flying restart U/f control status / FlyRest Uf st		
	Access level: 4	Calculated: -	Data type: Unsigned16
	Can be changed: -	Scaling: -	Dyn. index: -
	Unit group: -	Unit selection: -	Func. diagram: -
	Min	Max	Factory setting
	-	-	-
Description:	Displays the status for checking and monitoring flying restart states in the U/f control mode.		

2 Parameters

2.2 List of parameters

Bit field:	Bit	Signal name	1 signal	0 signal	FP
	00	Current impressed	Yes	No	-
	01	No current flow	Yes	No	-
	02	Voltage input	Yes	No	-
	03	Voltage reduced	Yes	No	-
	04	Start ramp-function generator	Yes	No	-
	05	Wait for execution	Yes	No	-
	06	Slope filter act	Yes	No	-
	07	Positive gradient	Yes	No	-
	08	Current < threshold	Yes	No	-
	09	Current minimum	Yes	No	-
	10	Search in the positive direction	Yes	No	-
	11	Stop after positive direction	Yes	No	-
	12	Stop after negative direction	Yes	No	-
	13	No result	Yes	No	-

r1205.0...15 CO/BO: Flying restart vector control status / FlyRest vector st

Access level: 4	Calculated: -	Data type: Unsigned32
Can be changed: -	Scaling: -	Dyn. index: -
Unit group: -	Unit selection: -	Func. diagram: -
Min	Max	Factory setting
-	-	-

Description: Display and connector output for the status for checking and monitoring flying restart states in the vector control mode.

Bit field:	Bit	Signal name	1 signal	0 signal	FP
	00	Speed adaptation circuit record angle	Yes	No	-
	01	Speed adaptation circuit set gain to 0	Yes	No	-
	02	Isd channel enable	Yes	No	-
	03	Speed control switched out	Yes	No	-
	04	Quadrature arm switched in	Yes	No	-
	05	Special transformation active	Yes	No	-
	06	Speed adaptation circuit set I component to 0	Yes	No	-
	07	Current control on	Yes	No	-
	08	Isd_set = 0 A	Yes	No	-
	09	Frequency held	Yes	No	-
	10	Search in the positive direction	Yes	No	-
	11	Search Started	Yes	No	-
	12	Current impressed	Yes	No	-
	13	Search interrupted	Yes	No	-
	14	Speed adaptation circuit deviation = 0	Yes	No	-
	15	Speed control activated	Yes	No	-

Note: For bit 00 ... 09:
Used to control internal sequences during the flying restart.
Depending on the motor type (p0300), the number of active bits differs.
For bits 10 ... 15:
Are used to monitor the flying restart sequence.

p1206[0...9] Automatic restart faults not active / AR fault not act

Access level: 3	Calculated: -	Data type: Unsigned16
Can be changed: U, T	Scaling: -	Dyn. index: -
Unit group: -	Unit selection: -	Func. diagram: -
Min	Max	Factory setting
0	65535	0

Description: Sets faults for which automatic restart should not be effective.

Dependency: The setting is only effective for p1210 = 6, 16, 26.
Refer to: p1210

p1210	Automatic restart mode / AR mode		
	Access level: 2	Calculated: -	Data type: Integer16
	Can be changed: U, T	Scaling: -	Dyn. index: -
	Unit group: -	Unit selection: -	Func. diagram: -
	Min	Max	Factory setting
	0	26	0
Description:	Sets the automatic restart mode (AR). The parameters must be saved in the non-volatile memory p0971 = 1 in order that the setting becomes effective.		
Value:	0: Inhibit automatic restart 1: Acknowledge all faults without restarting 4: Restart after line supply failure w/o additional start attempts 6: Restart after fault with additional start attempts 14: Restart after line supply failure following man. acknowledgment 16: Restart after fault following manual acknowledgment 26: Acknowledging all faults and reclosing for an ON command		
Recommendation:	For brief line supply failures, the motor shaft may still be rotating when restarting. The "flying restart" function (p1200) might need to be activated to restart while the motor shaft is still rotating.		
Dependency:	The automatic restart requires an active ON command (e.g., via a digital input). If, for p1210 > 1, there is no active ON command, then the automatic restart is interrupted. When using an Operator Panel in the LOCAL mode, then there is no automatic start. For p1210 = 14, 16, a manual acknowledgment is required for an automatic restart. Refer to: p0840, p0857 Refer to: F30003		
Danger: 	If the automatic restart is activated (p1210 > 1) if there is an ON command (refer to p0840), the drive is switched on as soon as any fault messages that are present can be acknowledged. This also occurs after the line supply returns or the Control Unit boots if the DC link voltage is present again. This automatic switching-on operation can only be interrupted by withdrawing the ON command.		
Notice:	A change is only accepted and made in the state "initialization" (r1214.0) and "wait for alarm" (r1214.1). When faults are present, therefore, the parameter cannot be changed. For p1210 > 1, the motor is automatically started.		
Note:	For p1210 = 1: Faults that are present are automatically acknowledged. If new faults occur after a successful fault acknowledgment, then these are also automatically acknowledged again. p1211 has no influence on the number of acknowledgment attempts. For p1210 = 4: An automatic restart is only performed if fault F30003 has occurred on the power unit. If additional faults are present, then these faults are also acknowledged and when successful, starting continues. If, for external 24 V power supplies of the Control Unit, additional faults subsequently occur, these are no longer interpreted as line faults and are therefore also not acknowledged. For p1210 = 6: An automatic restart is carried out if any fault has occurred. For p1210 = 14: as for p1210 = 4. However, active faults must be manually acknowledged. For p1210 = 16: as for p1210 = 6. However, active faults must be manually acknowledged. For p1210 = 26: as for p1210 = 6. For this mode, the switch-on command can be entered with a delay. The restart is interrupted with either OFF2 or OFF3. Alarm A07321 is only displayed if the cause of the fault has been removed and the drive is restarted by setting the switch-on command.		

p1211	Automatic restart start attempts / AR start attempts		
	Access level: 3	Calculated: -	Data type: Unsigned16
	Can be changed: U, T	Scaling: -	Dyn. index: -
	Unit group: -	Unit selection: -	Func. diagram: -
	Min	Max	Factory setting
	0	10	3
Description:	Sets the start attempts of the automatic restart function for p1210 = 4, 6, 14, 16, 26.		
Dependency:	A change is only accepted and made in the state "initialization" (r1214.0) and "wait for alarm" (r1214.1). Refer to: p1210, r1214 Refer to: F07320		
Notice:	After fault F07320 occurs, the switch-on command must be withdrawn and all of the faults acknowledged so that the automatic restart function is re-activated. After a complete power failure (blackout) the start counter always starts with the counter value that applied before the power failure, and decrements this start attempt by 1. If a further attempt to acknowledge is started by the automatic restart function prior to power failure, e.g. when the CU remains active on power failure longer than the time $p1212 / 2$, the fault counter will already have been decremented once. In this case, the start counter is thus decreased by the value 2.		
Note:	A start attempt starts immediately when a fault occurs. The start attempt is considered to be completed if the motor was magnetized ($r0056.4 = 1$) and an additional delay time of 1 s has expired. As long as a fault is present, an acknowledge command is generated in the time intervals of $p1212 / 2$. When successfully acknowledged, the start counter is decremented. If, after this, a fault re-occurs before a restart has been completed, then acknowledgment starts again from the beginning. Fault F07320 is output if, after several faults occur, the number of parameterized start attempts has been reached. After a successful start attempt, i.e. a fault/error has no longer occurred up to the end of the magnetizing phase, the start counter is again reset to the parameter value after 1 s. If a fault re-occurs - the parameterized number of start attempts is again available. At least one start attempt is always carried out. After a line supply failure, acknowledgment is immediate and when the line supply returns, the system is switched on. If, between successfully acknowledging the line fault and the line supply returning, another fault occurs, then its acknowledgment also causes the start counter to be decremented. For p1210 = 26: The start counter is decremented if after a successful fault acknowledgment, the on command is present.		

p1212	Automatic restart delay time start attempts / AR t_wait start		
	Access level: 3	Calculated: -	Data type: FloatingPoint32
	Can be changed: U, T	Scaling: -	Dyn. index: -
	Unit group: -	Unit selection: -	Func. diagram: -
	Min	Max	Factory setting
	0.1 [s]	1000.0 [s]	1.0 [s]
Description:	Sets the delay time up to restart.		
Dependency:	This parameter setting is active for p1210 = 4, 6, 26. For p1210 = 1, the following applies: Faults are only automatically acknowledged in half of the waiting time, no restart. Refer to: p1210, r1214		
Notice:	A change is only accepted and made in the state "initialization" (r1214.0) and "wait for alarm" (r1214.1).		
Note:	The faults are automatically acknowledged after half of the delay time has expired and the full delay time. If the cause of a fault is not removed in the first half of the delay time, then it is no longer possible to acknowledge in the delay time.		

p1213[0...1]	Automatic restart monitoring time / AR t_monit		
	Access level: 3	Calculated: -	Data type: FloatingPoint32
	Can be changed: U, T	Scaling: -	Dyn. index: -
	Unit group: -	Unit selection: -	Func. diagram: -
	Min	Max	Factory setting
	0.0 [s]	10000.0 [s]	[0] 60.0 [s] [1] 0.0 [s]
Description:	Sets the monitoring time of the automatic restart (AR).		
Index:	[0] = Restart [1] = Reset start counter		
Dependency:	Refer to: p1210, r1214		
Notice:	A change is only accepted and made in the state "initialization" (r1214.0) and "wait for alarm" (r1214.1). After fault F07320 occurs, the switch-on command must be withdrawn and all of the faults acknowledged so that the automatic restart function is re-activated.		
Note:	<p>For index [0]:</p> <p>The monitoring time starts when the faults are detected. If the automatic acknowledgments are not successful, the monitoring time runs again. If, after the monitoring time has expired, the drive has still not successfully started again (flying restart and magnetizing of the motor must have been completed: r0056.4 = 1), then fault F07320 is output. The monitoring is deactivated with p1213 = 0. If p1213 is set lower than the sum of p1212, the magnetizing time p0346 and the additional delay time due to the flying restart, then fault F07320 is generated at each restart. If, for p1210 = 1, the time in p1213 is set lower than in p1212, then fault F07320 is also generated at each restart. The monitoring time must be extended if the faults that occur cannot be immediately and successfully acknowledged (e.g. for faults that are permanently present). In the case of p1210 = 14, 16, the faults which are present must be acknowledged manually within the time in p1213[0]. Otherwise, fault F07320 is generated after the set time.</p> <p>For index [1]:</p> <p>The start counter (refer to r1214) is only set back to the starting value p1211 if, after successful restart, the time in p1213[1] has expired. The delay time is not effective for fault acknowledgment without automatic restart (p1210 = 1). After a power failure (blackout) the delay time only starts after the line supply returns and the Control Unit boots. The start counter is set to p1211, if F07320 occurred, the switch-on command is withdrawn and the fault is acknowledged. The start counter is immediately updated if the starting value p1211 or the mode p1210 is changed. For p1210 = 26, the monitoring time p1213[0] only elapses if there is an active switch-on command.</p>		

r1214.0...15	CO/BO: Automatic restart status / AR status				
	Access level: 4	Calculated: -	Data type: Unsigned16		
	Can be changed: -	Scaling: -	Dyn. index: -		
	Unit group: -	Unit selection: -	Func. diagram: -		
	Min	Max	Factory setting		
	-	-	-		
Description:	Displays the status of the automatic restart (AR).				
Bit field:	Bit	Signal name	1 signal	0 signal	FP
	00	Initialization	Yes	No	-
	01	Wait for alarm	Yes	No	-
	02	Auto restart act	Yes	No	-
	03	Setting the acknowledgment command	Yes	No	-
	04	Acknowledge alarms	Yes	No	-
	05	Restart	Yes	No	-
	06	Delay time running after automatic switch-on	Yes	No	-
	07	Fault	Yes	No	-
	10	Effective fault	Yes	No	-
	12	Start counter bit 0	ON	OFF	-
	13	Start counter bit 1	ON	OFF	-
	14	Start counter bit 2	ON	OFF	-
	15	Start counter bit 3	ON	OFF	-

Note:

For bit 00:
State to display the single initialization after POWER ON.

For bit 01:
State in which the automatic restart function waits for faults (initial state).

For bit 02:
General display that a fault has been identified and that the restart or acknowledgment has been initiated.

For bit 03:
Displays the acknowledge command within the "acknowledge alarms" state (bit 4 = 1). For bit 5 = 1 or bit 6 = 1, the acknowledge command is continually displayed.

For bit 04:
State in which the faults that are present are acknowledged. The state is exited again after successful acknowledgment. A change is only made into the next state if it is signaled that a fault is no longer present after an acknowledgment command (bit 3 = 1).

For bit 05:
State in which the drive is automatically switched on (only for p1210 = 4, 6).

For bit 06:
State in which the system waits after having been switched on, to the end of the start attempt (to the end of the magnetizing process).

For p1210 = 1, this signal is directly set after the faults have been successfully acknowledged.

For bit 07:
State which is assumed after a fault occurs within the automatic restart function. This is only reset after acknowledging the fault and withdrawing the switch-on command.

For bit 10:
When the automatic restart function is active, r1214.7 is displayed, otherwise the active fault r2139.3. The bit is set if the automatic restart can no longer acknowledge a fault, and cancels with fault F07320.

For bits 12 ... 15:
Actual state of the start counter (binary coded).

For bit 04 in addition:
For p1210 = 26, the system waits in this state until the switch-on command is available.

p1215

Motor holding brake configuration / Brake config

Access level: 2	Calculated: -	Data type: Integer16
Can be changed: C(1), T	Scaling: -	Dyn. index: -
Unit group: -	Unit selection: -	Func. diagram: 2701, 2707, 2711
Min	Max	Factory setting
0	3	0

Description: Sets the holding brake configuration.

Value:

0: No motor holding brake available
 1: Motor holding brake acc. to sequence control
 2: Motor holding brake always open
 3: Motor holding brake like sequence control connection via BICO

Dependency: Refer to: p1216, p1217, p1226, p1227, p1228

Caution: For the setting p1215 = 0, if a brake is used, it remains closed. If the motor moves, this will destroy the brake.



Notice: If p1215 was set to 1 or if p1215 was set to 3, then when the pulses are cancelled, the brake is closed even if the motor is still rotating. Pulse cancellation can either be caused by a 0 signal at p0844, p0845 or p0852 or as a result of a fault with OFF2 response. If this is not desirable (e.g. for a flying restart), then the brake can be kept open using a 1 signal at p0855.

Note: If a holding brake integrated in the motor is used, then it is not permissible that p1215 is set to 3. If an external motor holding brake is being used, then p1215 should be set to 3 and r0899.12 should be interconnected as control signal. The parameter can only be set to zero when the pulses are inhibited.

p1216	Motor holding brake opening time / Brake t_{open}		
	Access level: 2	Calculated: -	Data type: FloatingPoint32
	Can be changed: C(1), U, T	Scaling: -	Dyn. index: -
	Unit group: -	Unit selection: -	Func. diagram: 2701
	Min	Max	Factory setting
	0 [ms]	10000 [ms]	100 [ms]
Description:	Sets the time to open the motor holding brake. After the holding brake has been controlled (opened), the speed setpoint remains at zero for this time. The speed setpoint is then enabled.		
Recommendation:	This time should be set longer than the actual opening time of the brake. This ensures that the drive cannot accelerate when the brake is applied.		
Dependency:	Refer to: p1215, p1217		
Note:	For a motor with DRIVE-CLiQ and integrated brake, for p0300 = 10000, this time is pre-assigned the value saved in the motor.		
p1217	Motor holding brake closing time / Brake t_{close}		
	Access level: 2	Calculated: -	Data type: FloatingPoint32
	Can be changed: C(1), U, T	Scaling: -	Dyn. index: -
	Unit group: -	Unit selection: -	Func. diagram: 2701
	Min	Max	Factory setting
	0 [ms]	10000 [ms]	100 [ms]
Description:	Sets the time to apply the motor holding brake. After OFF1 or OFF3 and the controlling (closing) of the holding brake, the drive remains stationary under closed-loop control for this time with a speed setpoint of zero. The pulses are suppressed when the time expires.		
Recommendation:	This time should be set longer than the actual closing time of the brake. This ensures that the pulses are only suppressed after the brake has closed.		
Dependency:	Refer to: p1215, p1216		
Notice:	If the selected closing time is too short with respect to the actual closing time of the brake, then the load can sag. If the closing time is selected to be too long with respect to the actual closing time of the brake, the control works against the brake and therefore reduces its lifetime.		
Note:	For a motor with DRIVE-CLiQ and integrated brake, for p0300 = 10000, this time is pre-assigned the value saved in the motor.		
p1226[0...n]	Threshold for zero speed detection / n_{standst} n_{thresh}		
	Access level: 2	Calculated: -	Data type: FloatingPoint32
	Can be changed: U, T	Scaling: -	Dyn. index: DDS, p0180
	Unit group: 3_1	Unit selection: p0505	Func. diagram: 2701, 8022
	Min	Max	Factory setting
	0.00 [rpm]	210000.00 [rpm]	20.00 [rpm]
Description:	Sets the speed threshold for the standstill identification. Acts on the actual value and setpoint monitoring. When braking with OFF1 or OFF3, when the threshold is undershot, standstill is identified.		
Dependency:	Refer to: p1227		
Caution:	For closed-loop speed and torque control without encoder, the following applies: If p1226 is set to values under approx. 1 % of the rated motor speed, then the model switchover limits of the vector control must be increased in order to guarantee reliable shutdown (see p1755, p1750.7).		
Note:	Standstill is identified in the following cases: - the speed actual value falls below the speed threshold in p1226 and the time started after this in p1228 has expired. - the speed setpoint falls below the speed threshold in p1226 and the time started after this in p1227 has expired. The actual value sensing is subject to measuring noise. For this reason, standstill cannot be detected if the speed threshold is too low.		

p1227	Zero speed detection monitoring time / n_standst t_monit		
	Access level: 3	Calculated: -	Data type: FloatingPoint32
	Can be changed: U, T	Scaling: -	Dyn. index: -
	Unit group: -	Unit selection: -	Func. diagram: 2701
	Min	Max	Factory setting
	0.000 [s]	300.000 [s]	300.000 [s]
Description:	Sets the monitoring time for the standstill identification. When braking with OFF1 or OFF3, standstill is identified after this time has expired, after the setpoint speed has fallen below p1226 (also refer to p1145).		
Dependency:	The parameter is pre-assigned depending on the size of the power unit. Refer to: p1226		
Notice:	For p1145 > 0.0 (RFG tracking) the setpoint is not equal to zero dependent on the selected value. This can therefore cause the monitoring time in p1227 to be exceeded. In this case, for a driven motor, the pulses are not cancelled.		
Note:	Standstill is identified in the following cases: - the speed actual value falls below the speed threshold in p1226 and the time started after this in p1228 has expired. - the speed setpoint falls below the speed threshold in p1226 and the time started after this in p1227 has expired. For p1227 = 300.000 s the following applies: Monitoring is deactivated. For p1227 = 0.000 s, the following applies: With OFF1 or OFF3 and a ramp-down time = 0, the pulses are immediately suppressed and the motor "coasts" down. The parameters are preassigned according to the specific power unit once the Control Unit has been powered up for the first time or when the factory settings have been restored.		
p1228	Pulse cancellation delay time / Pulse suppr t_del		
	Access level: 3	Calculated: -	Data type: FloatingPoint32
	Can be changed: U, T	Scaling: -	Dyn. index: -
	Unit group: -	Unit selection: -	Func. diagram: 2701, 8022
	Min	Max	Factory setting
	0.000 [s]	299.000 [s]	0.010 [s]
Description:	Sets the delay time for pulse cancellation. After OFF1 or OFF3, the pulses are canceled, if at least one of the following conditions is fulfilled: - the speed actual value falls below the threshold in p1226 and the time started after this in p1228 has expired. - the speed setpoint falls below the threshold in p1226 and the time started after this in p1227 has expired.		
Dependency:	Refer to: p1226, p1227		
Notice:	When the motor holding brake is activated, pulse cancellation is additionally delayed by the brake closing time (p1217).		
p1230[0...n]	BI: DC braking activation / DC brake act		
	Access level: 2	Calculated: -	Data type: U32 / Binary
	Can be changed: U, T	Scaling: -	Dyn. index: CDS, p0170
	Unit group: -	Unit selection: -	Func. diagram: 7017
	Min	Max	Factory setting
	-	-	0
Description:	Sets the signal source to activate DC braking.		
Dependency:	Refer to: p1231, p1232, p1233, p1234, r1239		
Note:	1 signal: DC braking activated. 0 signal: DC braking deactivated.		

p1231[0...n]	DC braking configuration / DCBRK config		
Access level: 2	Calculated: -	Data type: Integer16	
Can be changed: U, T	Scaling: -	Dyn. index: DDS, p0180	
Unit group: -	Unit selection: -	Func. diagram: 7014, 7016, 7017	
Min	Max	Factory setting	
0	14	0	
Description:	Setting to activate DC braking.		
Value:	0: No function 4: DC braking 5: DC braking for OFF1/OFF3 14: DC braking below starting speed		
Dependency:	Refer to: p0300, p1232, p1233, p1234, r1239		
Note:	The function can only be used for induction motors (p0300 = 1). For p1231 = 4: The function is activated as soon as the activation criterion is fulfilled. - the function can be superseded by an OFF2 response. Activation criterion (one of the following criteria is fulfilled): - binector input p1230 = 1 signal (DC braking activation, depending on the operating mode). - the drive is not in the state "S4: Operation" or in "S5x". - the internal pulse enable is missing (r0046.19 = 0). DC braking can only be withdrawn (p1231 = 0) if it is not being used as a fault response in p2101. In order that DC braking is active as fault response, the corresponding fault number must be entered in p2100 and fault response p2101 set = 6. For p1231 = 5: DC braking is activated if the OFF1 or OFF3 command is present. Binector input p1230 is ineffective. If the drive speed still lies above the speed threshold p1234, then initially, the drive is ramped-down to this threshold, demagnetized (see p0347) and is then switched into DC braking for the time set in p1233. After this, the drive is switched-off. If, at OFF1, the drive speed is below p1234, then it is immediately demagnetized and switched into DC braking. A change is made into normal operation if the OFF1 command is withdrawn prematurely (the system waits for demagnetization). Flying restart must be activated if the motor is still rotating. DC braking by means of fault response continues to be possible. For p1231 = 14: In addition to the function for p1231 = 5, binector input p1230 is evaluated. DC braking is only automatically activated when the speed threshold p1234 is fallen below if binector input p1230 = 1 signal. This is also the case, if no OFF command is present. After demagnetization and after the time in p1233 has expired, the drive changes back into normal operation or is switched-off (for OFF1/OFF3). If a 0 signal is applied to binector input p1230, for OFF1 and OFF3 no DC braking is executed. Note: DCBRK: DC Braking		
p1232[0...n]	DC braking braking current / DCBRK I_brake		
Access level: 2	Calculated: p0340 = 1	Data type: FloatingPoint32	
Can be changed: U, T	Scaling: -	Dyn. index: DDS, p0180	
Unit group: -	Unit selection: -	Func. diagram: 7017	
Min	Max	Factory setting	
0.00 [Arms]	10000.00 [Arms]	0.00 [Arms]	
Description:	Sets the braking current for DC braking.		
Dependency:	Refer to: p1230, p1231, p1233, p1234, r1239, p1345, p1346		
Note:	A change to the braking current becomes effective the next time that DC braking is switched on. The value for p1232 is specified as an rms value in the 3-phase system. The magnitude of the braking current is the same as that of an identical output current at frequency zero (see r0067, r0068, p0640). The braking current is internally limited to r0067. For the current controller, the settings of parameters p1345 and p1346 (I_max limiting controller) are used.		

p1233[0...n]	DC braking time / DCBRK time			
	Access level: 2	Calculated: -	Data type: FloatingPoint32	
	Can be changed: U, T	Scaling: -	Dyn. index: DDS, p0180	
	Unit group: -	Unit selection: -	Func. diagram: 7017	
	Min	Max	Factory setting	
	0.0 [s]	3600.0 [s]	1.0 [s]	
Description:	Sets the DC braking time (as fault response).			
Dependency:	Refer to: p1230, p1231, p1232, p1234, r1239			
p1234[0...n]	Speed at the start of DC braking / DCBRK n_start			
	Access level: 2	Calculated: -	Data type: FloatingPoint32	
	Can be changed: U, T	Scaling: -	Dyn. index: DDS, p0180	
	Unit group: -	Unit selection: -	Func. diagram: 7017	
	Min	Max	Factory setting	
	0.00 [rpm]	210000.00 [rpm]	210000.00 [rpm]	
Description:	Sets the starting speed for DC braking. If the actual speed falls below this threshold, then DC braking is activated.			
Dependency:	Refer to: p1230, p1231, p1232, p1233, r1239			
r1239.8...13	CO/BO: DC braking status word / DCBRK ZSW			
	Access level: 2	Calculated: -	Data type: Unsigned32	
	Can be changed: -	Scaling: -	Dyn. index: -	
	Unit group: -	Unit selection: -	Func. diagram: -	
	Min	Max	Factory setting	
	-	-	-	
Description:	Status word of the DC braking.			
Bit field:	Bit	Signal name	1 signal	0 signal
	08	DC braking active	Yes	No
	10	DC braking ready	Yes	No
	11	DC braking selected	Yes	No
	12	DC braking selection internally inhibited	Yes	No
	13	DC braking for OFF1/OFF3	Yes	No
Dependency:	Refer to: p1231, p1232, p1233, p1234			
Note:	For bit 12, 13: Only effective for p1231 = 14.			
p1240[0...n]	Vdc controller configuration (vector control) / Vdc ctr config vec			
	Access level: 3	Calculated: -	Data type: Integer16	
	Can be changed: U, T	Scaling: -	Dyn. index: DDS, p0180	
	Unit group: -	Unit selection: -	Func. diagram: 6220	
	Min	Max	Factory setting	
	0	3	0	
Description:	Sets the controller configuration of the DC link voltage (Vdc controller) in the closed-loop control mode. For U/f control: see p1280.			
Value:	0: Inhibit Vdc ctrl 1: Enable Vdc_max controller 3: Enable Vdc_min controller and Vdc_max controller			
Dependency:	Refer to: p1245 Refer to: A07400, A07401, A07402, F07405, F07406			
Notice:	An excessively high value in p1245 can possibly negatively influence the normal operation of the drive.			

Note: If a braking resistor is connected to the DC link ($p0219 > 0$), then the Vdc_max control is automatically deactivated.
 $p1240 = 1, 3$:
 When the DC link voltage limit specified for the power unit is reached the following applies:
 - the Vdc_max controller limits the regenerative energy in order that the DC link voltage is kept below the maximum DC link voltage when braking.
 - the ramp-down times are automatically increased. If overvoltage faults occur in spite of the Vdc_max controller being active, the ramp-down time in $p1121$ might need to be increased.
 - set the input voltage $p0210$ as low as possible in line with the supply voltage (in so doing avoid A07401).
 $p1240 = 3$:
 When the switch-in threshold of the Vdc_min controller is reached ($p1245$), the following applies:
 - the Vdc_min controller limits the energy taken from the DC link in order to keep the DC link voltage above the minimum DC link voltage when accelerating.
 - the motor is braked in order to use its kinetic energy to buffer the DC link.
 - the Vdc_min controller cannot be used when the line voltage is permanently below 380 V (if required, $p1247$ should be reduced).

r1242	Vdc_max controller switch-in level / Vdc_max on_level		
	Access level: 3	Calculated: -	Data type: FloatingPoint32
	Can be changed: -	Scaling: $p2001$	Dyn. index: -
	Unit group: -	Unit selection: -	Func. diagram: 6220
	Min	Max	Factory setting
	- [V]	- [V]	- [V]
Description:	Displays the switch-in level for the Vdc_max controller. If $p1254 = 0$ (automatic sensing of the switch-in level = off), then the following applies: $r1242 = 1.15 * \sqrt{2} * p0210$ (supply voltage) If $p1254 = 1$ (automatic sensing of the switch-in level = on), then the following applies: $r1242 = Vdc_max - 90.0\text{ V}$ (Vdc_max: Overvoltage threshold of the power unit)		
Notice:	If the activation level of the Vdc_max controller is already exceeded in the deactivated state (pulse inhibit) by the DC link voltage, then the controller can be automatically deactivated (see F07401), so that the drive is not accelerated the next time that it is activated.		
Note:	The Vdc_max controller is not switched back off until the DC link voltage falls below the threshold $0.95 * r1242$ and the controller output is zero.		

p1243[0...n]	Vdc_max controller dynamic factor / Vdc_max dyn_factor		
	Access level: 3	Calculated: $p0340 = 1,3,4$	Data type: FloatingPoint32
	Can be changed: U, T	Scaling: -	Dyn. index: DDS, $p0180$
	Unit group: -	Unit selection: -	Func. diagram: 6220
	Min	Max	Factory setting
	1 [%]	10000 [%]	100 [%]
Description:	Sets the dynamic factor for the DC link voltage controller (Vdc_max controller). 100% means that $p1250$, $p1251$, and $p1252$ (gain, integral time, and rate time) are used corresponding to their basic settings and based on a theoretical controller optimization. If subsequent optimization is required, this can be carried out using the dynamic factor. In this case $p1250$, $p1251$, $p1252$ are weighted with the dynamic factor $p1243$.		

p1245[0...n]	Vdc_min controller switch-in level (kinetic buffering) / Vdc_min on_level		
	Access level: 3	Calculated: -	Data type: FloatingPoint32
	Can be changed: U, T	Scaling: -	Dyn. index: DDS, $p0180$
	Unit group: -	Unit selection: -	Func. diagram: -
	Min	Max	Factory setting
	65 [%]	150 [%]	76 [%]
Description:	Sets the switch-in level for the Vdc-min controller (kinetic buffering). The value is obtained as follows: $r1246[V] = p1245[\%] * \sqrt{2} * p0210$		
Dependency:	Refer to: $p0210$		

Warning: It is possible that an excessively high value can negatively impact normal converter operation, and can mean that after the line supply returns, the Vdc_min control can no longer be exited.



r1246	Vdc_min controller switch-in level (kinetic buffering) / Vdc_min on_level		
Access level: 3	Calculated: -	Data type: FloatingPoint32	
Can be changed: -	Scaling: p2001	Dyn. index: -	
Unit group: -	Unit selection: -	Func. diagram: 6220	
Min	Max	Factory setting	
- [V]	- [V]	- [V]	

Description: Displays the switch-in level for the Vdc_min controller (kinetic buffering).
Note: The Vdc_min controller is not switched back off until the DC link voltage rises above the threshold $1.05 \cdot p1246$ and the controller output is zero.

p1247[0...n]	Vdc_min controller dynamic factor (kinetic buffering) / Vdc_min dyn_factor		
Access level: 3	Calculated: p0340 = 1,3,4	Data type: FloatingPoint32	
Can be changed: U, T	Scaling: -	Dyn. index: DDS, p0180	
Unit group: -	Unit selection: -	Func. diagram: 6220	
Min	Max	Factory setting	
1 [%]	10000 [%]	300 [%]	

Description: Sets the dynamic factor for the Vdc_min controller (kinetic buffering).
 100% means that p1250, p1251, and p1252 (gain, integral time, and rate time) are used corresponding to their basic settings and based on a theoretical controller optimization.
 If subsequent optimization is required, this can be carried out using the dynamic factor. In this case p1250, p1251, p1252 are weighted with the dynamic factor p1247.

p1249[0...n]	Vdc_max controller speed threshold / Vdc_max n_thresh		
Access level: 3	Calculated: p0340 = 1	Data type: FloatingPoint32	
Can be changed: U, T	Scaling: -	Dyn. index: DDS, p0180	
Unit group: 3_1	Unit selection: p0505	Func. diagram: -	
Min	Max	Factory setting	
0.00 [rpm]	210000.00 [rpm]	10.00 [rpm]	

Description: Sets the lower speed threshold for the Vdc_max controller.
 When this speed threshold is undershot, the Vdc_max control is switched out and the speed is controlled using the ramp-function generator.
Note: For fast braking where the ramp-function generator tracking was active, it is possible to prevent the drive rotating in the opposite direction by increasing the speed threshold and setting a final rounding-off time in the ramp-function generator (p1131). This is supported using a dynamic setting of the speed controller.

p1250[0...n]	Vdc controller proportional gain / Vdc_ctrl Kp		
Access level: 3	Calculated: -	Data type: FloatingPoint32	
Can be changed: U, T	Scaling: -	Dyn. index: DDS, p0180	
Unit group: -	Unit selection: -	Func. diagram: -	
Min	Max	Factory setting	
0.00	100.00	1.00	

Description: Sets the proportional gain for the DC link voltage controller (Vdc_min controller, Vdc_max controller).
Dependency: The effective proportional gain is obtained taking into account p1243 (Vdc_max controller dynamic factor) and the DC link capacitance of the power unit.

p1251[0...n]	Vdc controller integral time / Vdc_ctrl Tn		
	Access level: 3	Calculated: -	Data type: FloatingPoint32
	Can be changed: U, T	Scaling: -	Dyn. index: DDS, p0180
	Unit group: -	Unit selection: -	Func. diagram: 6220
	Min	Max	Factory setting
	0 [ms]	10000 [ms]	0 [ms]
Description:	Sets the integral time for the DC link voltage controller (Vdc_min controller, Vdc_max controller).		
Dependency:	The effective integral time is obtained taking into account p1243 (Vdc_max controller dynamic factor).		
Note:	p1251 = 0: The integral component is deactivated.		
p1252[0...n]	Vdc controller rate time / Vdc_ctrl t_rate		
	Access level: 3	Calculated: -	Data type: FloatingPoint32
	Can be changed: U, T	Scaling: -	Dyn. index: DDS, p0180
	Unit group: -	Unit selection: -	Func. diagram: 6220
	Min	Max	Factory setting
	0 [ms]	1000 [ms]	0 [ms]
Description:	Sets the rate time constant for the DC link voltage controller (Vdc_min controller, Vdc_max controller).		
Dependency:	The effective rate time is obtained taking into account p1243 (Vdc_max controller dynamic factor).		
p1254	Vdc_max controller automatic ON level detection / Vdc_max SenseOnLev		
	Access level: 3	Calculated: -	Data type: Integer16
	Can be changed: U, T	Scaling: -	Dyn. index: -
	Unit group: -	Unit selection: -	Func. diagram: -
	Min	Max	Factory setting
	0	1	1
Description:	Activates/deactivates the automatic sensing of the switch-in level for the Vdc_max controller.		
Value:	0: Automatic detection inhibited 1: Automatic detection enabled		
p1255[0...n]	Vdc_min controller time threshold / Vdc_min t_thresh		
	Access level: 3	Calculated: -	Data type: FloatingPoint32
	Can be changed: U, T	Scaling: -	Dyn. index: DDS, p0180
	Unit group: -	Unit selection: -	Func. diagram: -
	Min	Max	Factory setting
	0.000 [s]	1800.000 [s]	0.000 [s]
Description:	Sets the time threshold for the Vdc_min controller (kinetic buffering). If this value is exceeded a fault is output; the required response can be parameterized. Prerequisite: p1256 = 1		
Dependency:	Refer to: F07406		
Notice:	If a time threshold has been parameterized, the Vdc_max controller should also be activated (p1240 = 3) so that the drive does not shut down with overvoltage when Vdc_min control is exited (due to the time violation) and in the event of fault response OFF3. It is also possible to increase the OFF3 ramp-down time p1135.		
p1256[0...n]	Vdc_min controller response (kinetic buffering) / Vdc_min response		
	Access level: 3	Calculated: -	Data type: Integer16
	Can be changed: U, T	Scaling: -	Dyn. index: DDS, p0180
	Unit group: -	Unit selection: -	Func. diagram: -
	Min	Max	Factory setting
	0	1	0
Description:	Sets the response for the Vdc_min controller (kinetic buffering).		
Value:	0: Buffer Vdc until undervoltage, n<p1257 -> F07405 1: Buff. Vdc until undervolt., n<p1257 -> F07405, t>p1255 -> F07406		
Dependency:	Refer to: F07405, F07406		

p1257[0...n]	Vdc_min controller speed threshold / Vdc_min n_thresh		
	Access level: 3	Calculated: p0340 = 1	Data type: FloatingPoint32
	Can be changed: U, T	Scaling: -	Dyn. index: DDS, p0180
	Unit group: 3_1	Unit selection: p0505	Func. diagram: -
	Min	Max	Factory setting
	0.00 [rpm]	210000.00 [rpm]	50.00 [rpm]
Description:	Sets the speed threshold for the Vdc-min controller (kinetic buffering). If this value is exceeded a fault is output; the required response can be parameterized . Kinetic buffering is not started below the speed threshold.		
Note:	Exiting the Vdc_min control before reaching motor standstill prevents the regenerative braking current from increasing significantly at low speeds, and after a pulse inhibit, means that the motor coasts down. However, the maximum braking torque can be set via the appropriate torque limiting.		
r1258	CO: Vdc controller output / Vdc_ctrl output		
	Access level: 3	Calculated: -	Data type: FloatingPoint32
	Can be changed: -	Scaling: p2002	Dyn. index: -
	Unit group: 6_2	Unit selection: p0505	Func. diagram: 6220
	Min	Max	Factory setting
	- [Arms]	- [Arms]	- [Arms]
Description:	Displays the actual output of the Vdc controller (DC link voltage controller)		
Note:	The regenerative power limit p1531 is used for vector control to precontrol the Vdc_max controller. The lower the power limit is set, the lower the correction signals of the controller when the voltage limit is reached.		
p1271[0...n]	Flying restart maximum frequency for the inhibited direction / FlyRes f_max dir		
	Access level: 3	Calculated: -	Data type: FloatingPoint32
	Can be changed: U, T	Scaling: -	Dyn. index: DDS, p0180
	Unit group: -	Unit selection: -	Func. diagram: -
	Min	Max	Factory setting
	0 [Hz]	650 [Hz]	0 [Hz]
Description:	Sets the maximum search frequency for a flying restart in an inhibited setpoint direction (p1110, p1111).		
Note:	The parameter has no effect for an operating mode, which only searches in the setpoint direction (p1200 > 3).		
p1280[0...n]	Vdc controller or Vdc monitoring configuration (U/f) / Vdc_ctr config U/f		
	Access level: 3	Calculated: -	Data type: Integer16
	Can be changed: U, T	Scaling: -	Dyn. index: DDS, p0180
	Unit group: -	Unit selection: -	Func. diagram: 6300, 6320
	Min	Max	Factory setting
	0	1	0
Description:	Sets the configuration of the controller for the DC link voltage (Vdc controller) in the U/f operating mode.		
Value:	0: Inhibit Vdc ctrl 1: Enable Vdc_max controller		
Note:	For high input voltages (p0210), the following settings can improve the degree of ruggedness of the Vdc_max controller: - set the input voltage as low as possible, and in so doing, avoid A07401 (p0210). - set the rounding times (p1130, p1136). - increase the ramp-down times (p1121). - reduce the integral time of the controller (p1291, factor 0.5). - reduce the rate time of the controller (p1292, factor 0.5). In this case, we generally recommend to use vector control (p1300 = 20) (Vdc controller, see p1240).		

p1281[0...n]	Vdc controller configuration / Vdc ctrl config			
	Access level: 3	Calculated: p0340 = 1	Data type: Unsigned16	
	Can be changed: U, T	Scaling: -	Dyn. index: DDS, p0180	
	Unit group: -	Unit selection: -	Func. diagram: -	
	Min	Max	Factory setting	
	-	-	0000 bin	
Description:	Sets the configuration for the DC link voltage controller.			
Bit field:	Bit	Signal name	1 signal	0 signal
	00	Vdc min control (U/f) without up ramp	Yes	No
	02	Vdc min shorter wait time when the line returns	Yes	No
				FP
				-
				-
Note:	For bit 00: Deactivate the ramp-up for Vdc_min control. For drives with a mechanical system that can oscillate and high moment of inertia, the speed can be more quickly tracked. For bit 02: When the line supply returns, normal operation is resumed earlier, and the system does not wait until the Vdc min controller reaches the setpoint speed.			
r1282	Vdc_max controller switch-in level (U/f) / Vdc_max on_level			
	Access level: 3	Calculated: -	Data type: FloatingPoint32	
	Can be changed: -	Scaling: p2001	Dyn. index: -	
	Unit group: -	Unit selection: -	Func. diagram: 6320	
	Min	Max	Factory setting	
	- [V]	- [V]	- [V]	
Description:	Displays the switch-in level for the Vdc_max controller. If p1294 = 0 (automatic sensing of the switch-in level = off), then the following applies: $r1282 = 1.15 * \sqrt{2} * p0210$ (supply voltage) If p1294 = 1 (automatic sensing of the switch-in level = on), then the following applies: $r1282 = Vdc_max - 90.0 \text{ V}$ (Vdc_max: Overvoltage threshold of the power unit)			
Notice:	If the activation level of the Vdc_max controller is already exceeded in the deactivated state (pulse inhibit) by the DC link voltage, then the controller can be automatically deactivated (see F07401), so that the drive is not accelerated the next time that it is activated.			
Note:	The Vdc_max controller is not switched back off until the DC link voltage falls below the threshold $0.95 * r1282$ and the controller output is zero.			
p1283[0...n]	Vdc_max controller dynamic factor (U/f) / Vdc_max dyn_factor			
	Access level: 3	Calculated: p0340 = 1,3,4	Data type: FloatingPoint32	
	Can be changed: U, T	Scaling: -	Dyn. index: DDS, p0180	
	Unit group: -	Unit selection: -	Func. diagram: 6320	
	Min	Max	Factory setting	
	1 [%]	10000 [%]	100 [%]	
Description:	Sets the dynamic factor for the DC link voltage controller (Vdc_max controller). 100% means that p1290, p1291, and p1292 (gain, integral time, and rate time) are used in accordance with their basic settings and on the basis of a theoretical controller optimization. If subsequent optimization is required, this can be carried out using the dynamic factor. In this case, p1290, p1291, and p1292 are weighted with the dynamic factor p1283.			

p1284[0...n]	Vdc_max controller time threshold (U/f) / Vdc_max t_thresh		
	Access level: 3	Calculated: p0340 = 1	Data type: FloatingPoint32
	Can be changed: U, T	Scaling: -	Dyn. index: DDS, p0180
	Unit group: -	Unit selection: -	Func. diagram: -
	Min	Max	Factory setting
	0.000 [s]	300.000 [s]	4.000 [s]
Description:	Sets the monitoring time for the Vdc_max controller. If the down ramp of the speed setpoint is held for longer than the time set in p1284, then fault F07404 is output.		
p1288[0...n]	Vdc_max controller feedback coupling factor ramp-fct. gen. (U/f) / Vdc_max factor RFG		
	Access level: 4	Calculated: -	Data type: FloatingPoint32
	Can be changed: U, T	Scaling: -	Dyn. index: DDS, p0180
	Unit group: -	Unit selection: -	Func. diagram: -
	Min	Max	Factory setting
	0.000	100.000	0.500
Description:	Sets the feedback factor for the ramp-function generator. Its ramp times are decelerated relative to the output signal of the Vdc_max controller.		
Note:	For values p1288 = 0.0 to 0.5, the controller dynamics are automatically adapted internally.		
p1290[0...n]	Vdc controller proportional gain (U/f) / Vdc_ctrl Kp		
	Access level: 3	Calculated: p0340 = 1,3,4	Data type: FloatingPoint32
	Can be changed: U, T	Scaling: -	Dyn. index: DDS, p0180
	Unit group: -	Unit selection: -	Func. diagram: 6320
	Min	Max	Factory setting
	0.00	100.00	1.00
Description:	Sets the proportional gain for the Vdc controller (DC link voltage controller).		
Note:	The gain factor is proportional to the capacitance of the DC link. The parameter is pre-set to a value that is optimally adapted to the capacitance of the power unit.		
p1291[0...n]	Vdc controller integral time (U/f) / Vdc_ctrl Tn		
	Access level: 3	Calculated: -	Data type: FloatingPoint32
	Can be changed: U, T	Scaling: -	Dyn. index: DDS, p0180
	Unit group: -	Unit selection: -	Func. diagram: 6320
	Min	Max	Factory setting
	0 [ms]	10000 [ms]	40 [ms]
Description:	Sets the integral time for the Vdc controller (DC link voltage controller).		
p1292[0...n]	Vdc controller rate time (U/f) / Vdc_ctrl t_rate		
	Access level: 3	Calculated: p0340 = 1,3,4	Data type: FloatingPoint32
	Can be changed: U, T	Scaling: -	Dyn. index: DDS, p0180
	Unit group: -	Unit selection: -	Func. diagram: 6320
	Min	Max	Factory setting
	0 [ms]	1000 [ms]	10 [ms]
Description:	Sets the rate time constant for the Vdc controller (DC link voltage controller).		

p1294	Vdc_max controller automatic detection ON signal level (U/f) / Vdc_max SenseOnLev		
	Access level: 3	Calculated: -	Data type: Integer16
	Can be changed: U, T	Scaling: -	Dyn. index: -
	Unit group: -	Unit selection: -	Func. diagram: -
	Min	Max	Factory setting
	0	1	0
Description:	Activates/deactivates the automatic sensing of the switch-in level for the Vdc_max controller. When the sensing function is deactivated, the activation threshold r1282 for the Vdc_max controller is determined from the parameterized connection voltage p0210.		
Value:	0: Automatic detection inhibited 1: Automatic detection enabled		
r1298	CO: Vdc controller output (U/f) / Vdc_ctrl output		
	Access level: 3	Calculated: -	Data type: FloatingPoint32
	Can be changed: -	Scaling: p2000	Dyn. index: -
	Unit group: 3_1	Unit selection: p0505	Func. diagram: 6320
	Min	Max	Factory setting
	- [rpm]	- [rpm]	- [rpm]
Description:	Displays the actual output of the Vdc controller (DC link voltage controller)		
p1300[0...n]	Open-loop/closed-loop control operating mode / Op/cl-lp ctrl_mode		
	Access level: 2	Calculated: -	Data type: Integer16
	Can be changed: C(1), T	Scaling: -	Dyn. index: DDS, p0180
	Unit group: -	Unit selection: -	Func. diagram: 6300, 6301, 8012
	Min	Max	Factory setting
	0	22	0
Description:	Sets the open and closed-loop control mode of a drive.		
Value:	0: U/f control with linear characteristic 1: U/f control with linear characteristic and FCC 2: U/f control with parabolic characteristic 3: U/f control with parameterizable characteristic 4: U/f control with linear characteristic and ECO 5: U/f control for drives requiring a precise freq. (e.g. textiles) 6: U/f control for drives requiring a precise frequency and FCC 7: U/f control for a parabolic characteristic and ECO 19: U/f control with independent voltage setpoint 20: Speed control (encoderless) 22: Torque control (encoderless)		
Dependency:	Only operation with U/f characteristic is possible if the rated motor speed is not entered (p0311). Operation with a U/f characteristic is not supported for 1LE4 synchronous motors. Refer to: p0300, p0311, p0500, p1501		
Notice:	Active slip compensation is required in the U/f control types with Eco mode (p1300 = 4, 7). The scaling of the slip compensation (p1335) should be set so that the slip is completely compensated (generally 100%). The Eco mode is only effective in steady-state operation and when the ramp-function generator is not bypassed. In the case of analog setpoints, if required the tolerance for ramp-up and ramp-down should be actively increased for the ramp-function generator using p1148 in order to reliably signal a steady-state condition.		
Note:	Only by selecting closed-loop speed control (p1300 = 20) is it possible to change over in operation to closed-loop torque control (p1501). At the changeover, the setting of p1300 does not change. In this case, the actual state is displayed in r1407, bit 2 and bit 3. For the open-loop control modes p1300 = 5 and 6 (textile sector), slip compensation p1335, resonance damping p1338, and the I _{max} frequency controller are switched off internally so that the output frequency can be set precisely. The I _{max} voltage controller remains active. During operation (pulses enabled) the open-loop/closed-loop control mode cannot be changed by changing over drive data sets.		

p1302[0...n]	U/f control configuration / U/f config				
	Access level: 3	Calculated: -	Data type: Unsigned16		
	Can be changed: T	Scaling: -	Dyn. index: DDS, p0180		
	Unit group: -	Unit selection: -	Func. diagram: -		
	Min	Max	Factory setting		
	-	-	0000 bin		
Description:	Sets the configuration for the U/f control.				
Bit field:	Bit	Signal name	1 signal	0 signal	FP
	03	Motor holding brake with constant stop frequency	Yes	No	-
Note:	For bit 03: When the bit is set, when the drive stops, the starting frequency of the motor holding brake is also not fallen below when the actual slip frequency is less than the starting frequency.				
p1310[0...n]	Starting current (voltage boost) permanent / I_start (Ua) perm				
	Access level: 2	Calculated: p0340 = 1	Data type: FloatingPoint32		
	Can be changed: U, T	Scaling: -	Dyn. index: DDS, p0180		
	Unit group: -	Unit selection: -	Func. diagram: 6300, 6301		
	Min	Max	Factory setting		
	0.0 [%]	250.0 [%]	50.0 [%]		
Description:	<p>Defines the voltage boost as a [%] referred to the rated motor current (p0305). The magnitude of the permanent voltage boost is reduced with increasing frequency so that at the rated motor frequency, the rated motor voltage is present. The magnitude of the boost in Volt at a frequency of zero is defined as follows: $\text{Voltage boost [V]} = 1.732 \times \text{p0305 (rated motor current [A])} \times \text{r0395 (stator/primary section resistance [ohm])} \times \text{p1310 (permanent voltage boost [\%])} / 100 \%$ At low output frequencies, there is only a low output voltage in order to maintain the motor flux. However, the output voltage can be too low in order to achieve the following:</p> <ul style="list-style-type: none"> - magnetize the induction motor. - hold the load. - compensate for losses in the system. <p>This is the reason that the output voltage can be increased using p1310. The voltage boost can be used for both linear as well as square-law U/f characteristics.</p>				
Dependency:	<p>The starting current (voltage boost) is limited by the current limit p0640. The accuracy of the starting current depends on the setting of the stator and feeder cable resistance (p0350, p0352). For vector control, the starting current is realized using p1610. Refer to: p1300, p1311, p1312, r1315</p>				
Notice:	The starting current (voltage boost) increases the motor temperature (particularly at zero speed).				
Note:	<p>The starting current as a result of the voltage boost is only effective for U/f control (p1300). The boost values are combined with one another if the permanent voltage boost (p1310) is used in conjunction with other boost parameters (acceleration boost (p1311), voltage boost for starting (p1312)). However, these parameters are assigned the following priorities: p1310 > p1311, p1312 For field orientation (p1302.4 = 1), p1311 and p1312 of the voltage boost are also added in the direction of the load current (non linear).</p>				

p1311[0...n]	Starting current (voltage boost) when accelerating / I_start accel		
	Access level: 2	Calculated: -	Data type: FloatingPoint32
	Can be changed: U, T	Scaling: -	Dyn. index: DDS, p0180
	Unit group: -	Unit selection: -	Func. diagram: 6300, 6301
	Min	Max	Factory setting
	0.0 [%]	250.0 [%]	0.0 [%]
Description:	p1311 only results in a voltage boost when accelerating and generates a supplementary torque to accelerate the load. The voltage boost becomes effective for a positive setpoint increase and disappears as soon as the setpoint has been reached. The build-up and withdrawal of the voltage boost are smoothed. The magnitude of the boost in Volt at a frequency of zero is defined as follows (not for field orientation): Voltage boost [V] = 1.732 * p0305 (rated motor current [A]) x r0395 (stator/primary section resistance [ohm]) x p1311 (voltage boost when accelerating [%]) / 100 %		
Dependency:	The current limit p0640 limits the boost. For vector control, the starting current is realized using p1611. Refer to: p1300, p1310, p1312, r1315		
Notice:	The voltage boost results in a higher motor temperature increase.		
Note:	The voltage boost when accelerating can improve the response to small, positive setpoint changes. Assigning priorities for the voltage boosts: refer to p1310		
p1312[0...n]	Starting current (voltage boost) when starting / I_start start		
	Access level: 2	Calculated: -	Data type: FloatingPoint32
	Can be changed: U, T	Scaling: -	Dyn. index: DDS, p0180
	Unit group: -	Unit selection: -	Func. diagram: 6300, 6301
	Min	Max	Factory setting
	0.0 [%]	250.0 [%]	0.0 [%]
Description:	Setting for an additional voltage boost when powering-up, however, only for the first acceleration phase. The voltage boost becomes effective for a positive setpoint increase and disappears as soon as the setpoint has been reached. The build-up and withdrawal of the voltage boost are smoothed.		
Dependency:	The current limit p0640 limits the boost. Refer to: p1300, p1310, p1311, r1315		
Notice:	The voltage boost results in a higher motor temperature increase.		
Note:	The voltage boost when accelerating can improve the response to small, positive setpoint changes. Assigning priorities for the voltage boosts: refer to p1310		
r1315	Voltage boost total / U_boost total		
	Access level: 3	Calculated: -	Data type: FloatingPoint32
	Can be changed: -	Scaling: p2001	Dyn. index: -
	Unit group: -	Unit selection: -	Func. diagram: 6301
	Min	Max	Factory setting
	- [Vrms]	- [Vrms]	- [Vrms]
Description:	Displays the total resulting voltage boost in volt.		
Dependency:	Refer to: p1310, p1311, p1312		
p1320[0...n]	U/f control programmable characteristic frequency 1 / Uf char f1		
	Access level: 3	Calculated: p0340 = 1	Data type: FloatingPoint32
	Can be changed: U, T	Scaling: -	Dyn. index: DDS, p0180
	Unit group: -	Unit selection: -	Func. diagram: 6301
	Min	Max	Factory setting
	0.00 [Hz]	3000.00 [Hz]	0.00 [Hz]
Description:	The programmable characteristic for the U/f control is defined using 4 points and 0 Hz/p1310. This parameter specifies the voltage of the first point along the characteristic.		

2 Parameters

2.2 List of parameters

Dependency: Selects the freely programmable characteristic using p1300 = 3.
The following applies to the frequency values: p1320 ≤ p1322 ≤ p1324 ≤ p1326. Otherwise, a standard characteristic is used that contains the rated motor operating point.
Refer to: p1300, p1310, p1311, p1321, p1322, p1323, p1324, p1325, p1326, p1327

Note: Linear interpolation is carried out between the points 0 Hz/p1310, p1320/p1321 ... p1326/p1327.
The voltage boost when accelerating (p1311) is also applied to the freely programmable U/f characteristic.

p1321[0...n] **U/f control programmable characteristic voltage 1 / Uf char U1**

Access level: 3	Calculated: p0340 = 1	Data type: FloatingPoint32
Can be changed: U, T	Scaling: -	Dyn. index: DDS, p0180
Unit group: -	Unit selection: -	Func. diagram: 6301
Min	Max	Factory setting
0.0 [Vrms]	10000.0 [Vrms]	0.0 [Vrms]

Description: The programmable characteristic for the U/f control is defined using 4 points and 0 Hz/p1310.
This parameter specifies the voltage of the first point along the characteristic.

Dependency: Selects the freely programmable characteristic using p1300 = 3.
Refer to: p1310, p1311, p1320, p1322, p1323, p1324, p1325, p1326, p1327

Note: Linear interpolation is carried out between the points 0 Hz/p1310, p1320/p1321 ... p1326/p1327.
The voltage boost when accelerating (p1311) is also applied to the freely programmable U/f characteristic.

p1322[0...n] **U/f control programmable characteristic frequency 2 / Uf char f2**

Access level: 3	Calculated: p0340 = 1	Data type: FloatingPoint32
Can be changed: U, T	Scaling: -	Dyn. index: DDS, p0180
Unit group: -	Unit selection: -	Func. diagram: 6301
Min	Max	Factory setting
0.00 [Hz]	3000.00 [Hz]	0.00 [Hz]

Description: The programmable characteristic for the U/f control is defined using 4 points and 0 Hz/p1310.
This parameter specifies the voltage of the second point along the characteristic.

Dependency: The following applies to the frequency values: p1320 ≤ p1322 ≤ p1324 ≤ p1326. Otherwise, a standard characteristic is used that contains the rated motor operating point.
Refer to: p1310, p1311, p1320, p1321, p1323, p1324, p1325, p1326, p1327

p1323[0...n] **U/f control programmable characteristic voltage 2 / Uf char U2**

Access level: 3	Calculated: p0340 = 1	Data type: FloatingPoint32
Can be changed: U, T	Scaling: -	Dyn. index: DDS, p0180
Unit group: -	Unit selection: -	Func. diagram: 6301
Min	Max	Factory setting
0.0 [Vrms]	10000.0 [Vrms]	0.0 [Vrms]

Description: The programmable characteristic for the U/f control is defined using 4 points and 0 Hz/p1310.
This parameter specifies the voltage of the second point along the characteristic.

Dependency: Refer to: p1310, p1311, p1320, p1321, p1322, p1324, p1325, p1326, p1327

p1324[0...n] **U/f control programmable characteristic frequency 3 / Uf char f3**

Access level: 3	Calculated: p0340 = 1	Data type: FloatingPoint32
Can be changed: U, T	Scaling: -	Dyn. index: DDS, p0180
Unit group: -	Unit selection: -	Func. diagram: 6301
Min	Max	Factory setting
0.00 [Hz]	3000.00 [Hz]	0.00 [Hz]

Description: The programmable characteristic for the U/f control is defined using 4 points and 0 Hz/p1310.
This parameter specifies the voltage of the third point along the characteristic.

Dependency: The following applies to the frequency values: p1320 ≤ p1322 ≤ p1324 ≤ p1326. Otherwise, a standard characteristic is used that contains the rated motor operating point.
Refer to: p1310, p1311, p1320, p1321, p1322, p1323, p1325, p1326, p1327

p1325[0...n]	U/f control programmable characteristic voltage 3 / Uf char U3		
	Access level: 3	Calculated: p0340 = 1	Data type: FloatingPoint32
	Can be changed: U, T	Scaling: -	Dyn. index: DDS, p0180
	Unit group: -	Unit selection: -	Func. diagram: 6301
	Min	Max	Factory setting
	0.0 [Vrms]	10000.0 [Vrms]	0.0 [Vrms]
Description:	The programmable characteristic for the U/f control is defined using 4 points and 0 Hz/p1310. This parameter specifies the voltage of the third point along the characteristic.		
Dependency:	Refer to: p1310, p1311, p1320, p1321, p1322, p1323, p1324, p1326, p1327		
p1326[0...n]	U/f control programmable characteristic frequency 4 / Uf char f4		
	Access level: 3	Calculated: p0340 = 1,3	Data type: FloatingPoint32
	Can be changed: U, T	Scaling: -	Dyn. index: DDS, p0180
	Unit group: -	Unit selection: -	Func. diagram: 6301
	Min	Max	Factory setting
	0.00 [Hz]	10000.00 [Hz]	0.00 [Hz]
Description:	The programmable characteristic for the U/f control is defined using 4 points and 0 Hz/p1310. This parameter specifies the frequency of the fourth point along the characteristic.		
Dependency:	Selects the freely programmable characteristic using p1300 = 3. The following applies for the frequency values: p1320 <= p1322 <= p1324 <= p1326 Otherwise, a standard characteristic is used that contains the rated motor operating point. Refer to: p1310, p1311, p1320, p1321, p1322, p1323, p1324, p1325, p1327		
Note:	Linear interpolation is carried out between the points 0 Hz/p1310, p1320/p1321 ... p1326/p1327. For output frequencies above p1326, the characteristic is extrapolated with the gradient between the characteristic points p1324/p1325 and p1326/p1327. The voltage boost when accelerating (p1311) is also applied to the freely programmable U/f characteristic.		
p1327[0...n]	U/f control programmable characteristic voltage 4 / Uf char U4		
	Access level: 3	Calculated: p0340 = 1,3	Data type: FloatingPoint32
	Can be changed: U, T	Scaling: -	Dyn. index: DDS, p0180
	Unit group: -	Unit selection: -	Func. diagram: 6301
	Min	Max	Factory setting
	0.0 [Vrms]	10000.0 [Vrms]	0.0 [Vrms]
Description:	The programmable characteristic for the U/f control is defined using 4 points and 0 Hz/p1310. This parameter specifies the voltage of the fourth point along the characteristic.		
Dependency:	Selects the freely programmable characteristic using p1300 = 3. Refer to: p1310, p1311, p1320, p1321, p1322, p1323, p1324, p1325, p1326		
Note:	Linear interpolation is carried out between the points 0 Hz/p1310, p1320/p1321 ... p1326/p1327. The voltage boost when accelerating (p1311) is also applied to the freely programmable U/f characteristic.		
p1330[0...n]	CI: U/f control independent voltage setpoint / Uf U_set independ.		
	Access level: 3	Calculated: -	Data type: U32 / FloatingPoint32
	Can be changed: T	Scaling: p2001	Dyn. index: CDS, p0170
	Unit group: -	Unit selection: -	Func. diagram: 6301
	Min	Max	Factory setting
	-	-	0
Description:	Sets the signal source for the voltage setpoint for U/f control with an independent voltage setpoint (p1300 = 19).		
Dependency:	Selects the U/f control with independent voltage setpoint via p1300 = 19. Refer to: p1300		

p1331[0...n]	Voltage limiting / U_lim		
	Access level: 3 Can be changed: U, T Unit group: 5_1 Min 50.00 [Vrms]	Calculated: - Scaling: - Unit selection: p0505 Max 2000.00 [Vrms]	Data type: FloatingPoint32 Dyn. index: DDS, p0180 Func. diagram: 6300 Factory setting 1000.00 [Vrms]
Description:	Limiting the voltage setpoint. This means that the output voltage can be reduced with respect to the calculated maximum voltage r0071 and the start of field weakening.		
Note:	The output voltage is only limited if, as a result of p1331, the maximum output voltage (r0071) is fallen below.		
p1333[0...n]	U/f control FCC starting frequency / U/f FCC f_start		
	Access level: 3 Can be changed: U, T Unit group: - Min 0.00 [Hz]	Calculated: p0340 = 1 Scaling: - Unit selection: - Max 3000.00 [Hz]	Data type: FloatingPoint32 Dyn. index: DDS, p0180 Func. diagram: 6301 Factory setting 0.00 [Hz]
Description:	Sets the starting frequency at which FCC (Flux Current Control) is activated.		
Dependency:	The correct operating mode must be set (p1300 = 1, 6).		
Warning:	An excessively low value can result in instability.		
			
Note:	For p1333 = 0 Hz, the FCC starting frequency is automatically set to 6 % of the rated motor frequency.		
p1334[0...n]	U/f control slip compensation starting frequency / Slip comp start		
	Access level: 3 Can be changed: U, T Unit group: - Min 0.00 [Hz]	Calculated: p0340 = 1 Scaling: - Unit selection: - Max 3000.00 [Hz]	Data type: FloatingPoint32 Dyn. index: DDS, p0180 Func. diagram: 6310 Factory setting 0.00 [Hz]
Description:	Sets the starting frequency of the slip compensation.		
Note:	For p1334 = 0, the starting frequency of the slip compensation is automatically set to 6 % of the rated motor frequency.		
p1335[0...n]	Slip compensation scaling / Slip comp scal		
	Access level: 3 Can be changed: U, T Unit group: - Min 0.0 [%]	Calculated: p0340 = 1 Scaling: - Unit selection: - Max 600.0 [%]	Data type: FloatingPoint32 Dyn. index: DDS, p0180 Func. diagram: 6300, 6310 Factory setting 0.0 [%]
Description:	Sets the setpoint for slip compensation in [%] referred to r0330 (motor rated slip). p1335 = 0.0 %: Slip compensation deactivated. p1335 = 100.0 %: The slip is completely compensated.		
Dependency:	Prerequisite for a precise slip compensation for p1335 = 100 % are the precise motor parameters (p0350 ... p0360). If the parameters are not precisely known, a precise compensation can be achieved by varying p1335. For U/f control types with Eco optimization (4 and 7), the slip compensation must be activated in order to guarantee correct operation.		

Note: The purpose of slip compensation is to maintain a constant motor speed regardless of the applied load. The fact that the motor speed decreases with increasing load is a typical characteristic of induction motors. For synchronous motors, this effect does not occur and the parameter has no effect in this case. For the open-loop control modes p1300 = 5 and 6 (textile sector), the slip compensation is internally disabled in order to be able to precisely set the output frequency. If p1335 is changed during commissioning (p0010 > 0), then it is possible that the old value will no longer be able to be set. The reason for this is that the dynamic limits of p1335 have been changed by a parameter that was set when the drive was commissioned (e.g. p0300).

p1336[0...n]	Slip compensation limit value / Slip comp lim val		
	Access level: 3	Calculated: -	Data type: FloatingPoint32
	Can be changed: U, T	Scaling: -	Dyn. index: DDS, p0180
	Unit group: -	Unit selection: -	Func. diagram: 6310
	Min	Max	Factory setting
	0.00 [%]	600.00 [%]	250.00 [%]
Description:	Sets the limit value for slip compensation in [%] referred to r0330 (motor rated slip).		

r1337	CO: Actual slip compensation / Slip comp act val		
	Access level: 3	Calculated: -	Data type: FloatingPoint32
	Can be changed: -	Scaling: PERCENT	Dyn. index: -
	Unit group: -	Unit selection: -	Func. diagram: 6310
	Min	Max	Factory setting
	- [%]	- [%]	- [%]
Description:	Displays the actual compensated slip [%] referred to r0330 (rated motor slip).		
Dependency:	p1335 > 0 %: Slip compensation active. Refer to: p1335		

p1338[0...n]	U/f mode resonance damping gain / Uf Res_damp gain		
	Access level: 3	Calculated: p0340 = 1,3,4	Data type: FloatingPoint32
	Can be changed: U, T	Scaling: -	Dyn. index: DDS, p0180
	Unit group: -	Unit selection: -	Func. diagram: 6300, 6310
	Min	Max	Factory setting
	0.00	100.00	0.00
Description:	Sets the gain for resonance damping for U/f control.		
Dependency:	Refer to: p1300, p1339, p1349		
Note:	The resonance damping function dampens active current oscillations that frequency occur under no-load conditions. The resonance damping is active in a range from approximately 6 % of the rated motor frequency (p0310). The shutoff frequency is determined by p1349. For the open-loop control modes p1300 = 5 and 6 (textile sectors), the resonance damping is internally disabled in order that the output frequency can be precisely set.		

p1339[0...n]	U/f mode resonance damping filter time constant / Uf Res_damp T		
	Access level: 4	Calculated: p0340 = 1,3,4	Data type: FloatingPoint32
	Can be changed: U, T	Scaling: -	Dyn. index: DDS, p0180
	Unit group: -	Unit selection: -	Func. diagram: 6310
	Min	Max	Factory setting
	1.00 [ms]	1000.00 [ms]	20.00 [ms]
Description:	Sets the filter time constant for resonance damping for U/f control.		
Dependency:	Refer to: p1300, p1338, p1349		

p1340[0...n]	I_max frequency controller proportional gain / I_max_ctrl Kp		
	Access level: 3	Calculated: p0340 = 1,3,4	Data type: FloatingPoint32
	Can be changed: U, T	Scaling: -	Dyn. index: DDS, p0180
	Unit group: -	Unit selection: -	Func. diagram: 6300
	Min	Max	Factory setting
	0.000	0.500	0.000
Description:	Sets the proportional gain of the I_max frequency controller. The I_max controller reduces the drive converter output current if the maximum current (r0067) is exceeded. In the U/f operating modes (p1300) for the I_max control, one controller is used that acts on the output frequency and one controller that acts on the output voltage. The frequency controller reduces the current by decreasing the converter output frequency. The frequency is reduced down to a minimum value (equaling twice rated slip). If the overcurrent condition cannot be successfully resolved using this measure, then the drive converter output voltage is reduced using the I_max voltage controller. Once the overcurrent condition has been resolved, the drive is accelerated along the ramp set in p1120 (ramp-up time).		
Dependency:	In the U/f modes (p1300) for textile applications and for external voltage setpoints, only the I_max voltage controller is used.		
Notice:	When deactivating the I_max controller, the following must be carefully observed: When the maximum current (r0067) is exceeded, the output current is no longer reduced. The drive is switched off when the overcurrent limits are exceeded.		
Note:	The I_max limiting controller becomes ineffective if the ramp-function generator is deactivated with p1122 = 1. p1341 = 0: I_max frequency controller deactivated and I_max voltage controller activated over the complete speed range.		

p1341[0...n]	I_max frequency controller integral time / I_max_ctrl Tn		
	Access level: 3	Calculated: p0340 = 1,3,4	Data type: FloatingPoint32
	Can be changed: U, T	Scaling: -	Dyn. index: DDS, p0180
	Unit group: -	Unit selection: -	Func. diagram: 6300
	Min	Max	Factory setting
	0.000 [s]	50.000 [s]	0.300 [s]
Description:	Sets the integral time for the I_max frequency controller.		
Dependency:	Refer to: p1340		
Note:	When p1341 = 0, the current limiting controller influencing the frequency is deactivated and only the current limiting controller influencing the output voltage remains active (p1345, p1346). This current limiting function is deactivated with p1340 = p1341 = 0.		

r1343	CO: I_max controller frequency output / I_max_ctrl f_outp		
	Access level: 3	Calculated: -	Data type: FloatingPoint32
	Can be changed: -	Scaling: p2000	Dyn. index: -
	Unit group: 3_1	Unit selection: p0505	Func. diagram: 6300
	Min	Max	Factory setting
	- [rpm]	- [rpm]	- [rpm]
Description:	Displays the effective frequency limit.		
Dependency:	Refer to: p1340		

r1344	I_max controller voltage output / I_max_ctrl U_outp		
	Access level: 3	Calculated: -	Data type: FloatingPoint32
	Can be changed: -	Scaling: p2001	Dyn. index: -
	Unit group: 5_1	Unit selection: p0505	Func. diagram: 6300
	Min	Max	Factory setting
	- [Vrms]	- [Vrms]	- [Vrms]
Description:	Displays the amount by which the converter output voltage is reduced.		
Dependency:	Refer to: p1340		

p1345[0...n]	I_max voltage controller proportional gain / I_max_U_ctrl Kp		
	Access level: 3	Calculated: p0340 = 1,3,4	Data type: FloatingPoint32
	Can be changed: U, T	Scaling: -	Dyn. index: DDS, p0180
	Unit group: -	Unit selection: -	Func. diagram: 6300, 7017
	Min	Max	Factory setting
	0.000	100000.000	0.000
Description:	Sets the proportional gain for the I_max voltage controller.		
Dependency:	Refer to: p1340		
Note:	The controller settings are also used in the current controller of the DC braking (refer to p1232).		
p1346[0...n]	I_max voltage controller integral time / I_max_U_ctrl Tn		
	Access level: 3	Calculated: p0340 = 1,3,4	Data type: FloatingPoint32
	Can be changed: U, T	Scaling: -	Dyn. index: DDS, p0180
	Unit group: -	Unit selection: -	Func. diagram: 6300, 7017
	Min	Max	Factory setting
	0.000 [s]	50.000 [s]	0.030 [s]
Description:	Sets the integral time for the I_max voltage controller.		
Dependency:	Refer to: p1340		
Note:	The controller settings are also used in the current controller of the DC braking (refer to p1232). For p1346 = 0, the following applies: The integral time of the I_max voltage controller is deactivated.		
r1348	CO: U/f control Eco factor actual value / U/f Eco fac act v		
	Access level: 4	Calculated: -	Data type: FloatingPoint32
	Can be changed: -	Scaling: PERCENT	Dyn. index: -
	Unit group: -	Unit selection: -	Func. diagram: 6300, 6301
	Min	Max	Factory setting
	- [%]	- [%]	- [%]
Description:	Displays the economic factor determined for optimizing motor consumption.		
Dependency:	Refer to: p1335		
Note:	The value is only determined for operating modes with Economic (p1300 = 4, 7).		
p1349[0...n]	U/f mode resonance damping maximum frequency / Uf res_damp f_max		
	Access level: 3	Calculated: p0340 = 1	Data type: FloatingPoint32
	Can be changed: U, T	Scaling: -	Dyn. index: DDS, p0180
	Unit group: -	Unit selection: -	Func. diagram: 6310
	Min	Max	Factory setting
	0.00 [Hz]	3000.00 [Hz]	0.00 [Hz]
Description:	Sets the maximum output frequency for resonance damping for U/f control. Resonance damping is inactive above this output frequency.		
Dependency:	Refer to: p1338, p1339		
Note:	For p1349 = 0, the changeover limit is automatically set to 95 % of the rated motor frequency - however, to a max. of 45 Hz.		
p1350[0...n]	U/f control soft start / U/f soft start		
	Access level: 3	Calculated: -	Data type: Integer16
	Can be changed: U, T	Scaling: -	Dyn. index: DDS, p0180
	Unit group: -	Unit selection: -	Func. diagram: 6300
	Min	Max	Factory setting
	0	1	0
Description:	Sets whether the voltage is continuously increased during the magnetizing phase (p1350 = 1, On) or whether it jumps directly to the voltage boost (p1350 = 0, Off).		

2 Parameters

2.2 List of parameters

Value: 0: OFF
1: ON

Note: The settings for this parameter have the following advantages and disadvantages:
0 = off (jump directly to voltage boost)
Advantage: Flux is established quickly -> torque is quickly available
Disadvantage: The motor can move while it is being magnetized
1 = on (voltage is continually established)
Advantage: The motor is unlikely to rotate
Disadvantage: The flux is established slower -> torque is available later

p1351[0...n]	CO: Motor holding brake starting frequency / Brake f_start		
	Access level: 3	Calculated: -	Data type: FloatingPoint32
	Can be changed: U, T	Scaling: PERCENT	Dyn. index: DDS, p0180
	Unit group: -	Unit selection: -	Func. diagram: 6310
	Min	Max	Factory setting
	-300.00 [%]	300.00 [%]	0.00 [%]
Description:	Sets the frequency setting value at the slip compensation output for starting up with motor holding brake.		
Dependency:	When setting p1351 > 0, then slip compensation is automatically activated (p1335 = 100 %). Refer to: p1302, p1352		
Notice:	A BICO interconnection to a parameter that belongs to a drive data set always acts on the effective data set.		
Note:	Connected with p1352 a value of 100% corresponds to the motor rated slip (r0330).		

p1352[0...n]	CI: Motor holding brake starting frequency signal source / Brake f_start		
	Access level: 3	Calculated: -	Data type: U32 / FloatingPoint32
	Can be changed: T	Scaling: PERCENT	Dyn. index: CDS, p0170
	Unit group: -	Unit selection: -	Func. diagram: 6310
	Min	Max	Factory setting
	-	-	1351[0]
Description:	Sets the signal source for the frequency setting value at the slip compensation output for starting up with motor holding brake.		
Dependency:	Refer to: p1216		
Note:	A value of 100% corresponds to the motor rated slip (r0330). The setting of the starting frequency begins after magnetizing (see p0346, r0056.4) and ends once the brake opening time (p1216) has elapsed and the starting frequency (p1334) has been reached. A setting value of zero means that no setting procedure will take place.		

p1382[0...n]	Saturation limit for flux setpoint / Max FluxSaturation		
	Access level: 4	Calculated: p0340 = 1	Data type: FloatingPoint32
	Can be changed: U, T	Scaling: -	Dyn. index: DDS, p0180
	Unit group: -	Unit selection: -	Func. diagram: -
	Min	Max	Factory setting
	100 [%]	130 [%]	100 [%]
Description:	Maximum flux setpoint (saturation limit) for calculating the EMF in the range of the impressed starting current.		

p1400[0...n]	Speed control configuration / n_ctrl config		
	Access level: 3	Calculated: -	Data type: Unsigned32
	Can be changed: U, T	Scaling: -	Dyn. index: DDS, p0180
	Unit group: -	Unit selection: -	Func. diagram: 6490
	Min	Max	Factory setting
	-	-	0000 0000 0000 0000 1000 0000 0010 0001 bin
Description:	Sets the configuration for the closed-loop speed control.		

Bit field:	Bit	Signal name	1 signal	0 signal	FP
	00	Automatic Kp/Tn adaptation active	Yes	No	6040
	01	Sensorless vector control freeze I comp	Yes	No	6040
	05	Kp/Tn adaptation active	Yes	No	6040
	06	Free Tn adaptation active	Yes	No	6050
	14	Torque precontrol	Always active	For n_ctrl enab	6060
	15	Sensorless vector control speed precontrol	Yes	No	6030
	16	I component for limiting	Enable	Hold	6030
	18	Moment of inertia estimator active	Yes	No	6030
	20	Acceleration model	ON	OFF	6031
	22	Obtain moment of inertia estimator value for pulse inhibit	Yes	No	6030
	24	Moment of inertia estimator fast estimation active	Yes	No	6030
	25	Acceleration torque instantaneous in the I/f mode	Yes	No	-

Note:

For bit 01:
When the bit is set, the I component of the speed controller is kept when changing into the open-loop controlled mode.

For bit 16:
When the bit is set, the integral component of the speed controller is only held if it reaches the torque limit.

For bit 20:
The acceleration model for the speed setpoint is only active for sensorless vector control if p1496 is not zero.

For bit 25:
When the bit is set, for high dynamic starting in the I/f mode, the acceleration precontrol torque smoothing only has a short minimum time (4 ms).

p1401[0...n]	Flux control configuration / Flux ctrl config		
	Access level: 3	Calculated: -	Data type: Unsigned16
	Can be changed: U, T	Scaling: -	Dyn. index: DDS, p0180
	Unit group: -	Unit selection: -	Func. diagram: 6491
	Min	Max	Factory setting
	-	-	0000 0000 0000 0110 bin

Description: Sets the configuration for flux setpoint control

Bit field:	Bit	Signal name	1 signal	0 signal	FP
	00	Flux setpoint soft starting active	Yes	No	6722
	01	Flux setpoint differentiation active	Yes	No	6723
	02	Flux build-up control active	Yes	No	6722, 6723
	03	Flux characteristic load-dependent	Yes	No	6725
	06	Quick magnetizing	Yes	No	6722
	07	Precontrol speed limitation	Yes	No	6640
	09	Dynamic load-dependent flux boost	Yes	No	6790, 6823
	10	Flux boost low speed	Yes	No	-
	14	Efficiency optimization 2 active	Yes	No	6722, 6837

2 Parameters

2.2 List of parameters

Note:

For bit 00 (not for permanent-magnet synchronous motors):

Initially, the flux is only established with a low rate of rise when magnetizing the induction motor. The flux setpoint p1570 is reached again at the end of the magnetizing time p0346.

For bit 01 (not for permanent-magnet synchronous motors):

Initially, the flux is only established with a low rate of rise when magnetizing the induction motor. The flux setpoint p1570 is reached again at the end of the magnetizing time p0346. When quick magnetizing (p1401.6 = 1) is selected, soft starting is internally deactivated and alarm A07416 is displayed.

The flux differentiation can be switched out if a significant ripple occurs in the field-generating current setpoint (r0075) when entering the field weakening range. However, this is not suitable for fast acceleration operations because then, the flux decays more slowly and the voltage limiting responds.

For bit 02 (not for permanent-magnet synchronous motors):

The flux build-up control operates during the magnetizing phase p0346 of the induction motor. If it is switched out, a constant current setpoint is injected and the flux is built up corresponding to the rotor time constant. When quick magnetizing (p1401.6 = 1) is selected and when flux build-up control is de-energized alarm A07416 is displayed.

For bit 03:

Synchronous reluctance motor (RESM):

Activation of the load-dependent optimum flux characteristic.

For bit 06 (not for induction motors):

Magnetizing is performed with maximum current ($0.9 * r0067$). With active identification of the stator resistance (see p0621) quick magnetizing is internally deactivated and alarm A07416 is displayed. During a flying restart of a rotating motor (see p1200) no quick magnetizing takes place.

For bit 07:

if the speed of the drive exceeds the effective speed limit of the speed limiting controller, the torque limit is reduced linearly to zero as the deviation becomes greater. This reduces the integral component of the speed controller and, in turn, the overshoot during load shedding (see also F07901 and p2162).

For bit 09:

Synchronous reluctance motor (RESM):

Dynamic increase in the flux setpoint when torque is quickly established.

For bit 10:

Synchronous reluctance motor (RESM):

For load-dependent optimum flux characteristic (p1401.3 = 1) the flux setpoint is increased at low speeds.

For bit 14:

When the function is activated, the following applies:

- the optimum flux is calculated and the power loss is entered for optimization purposes
- the efficiency optimization (p1580) is not active.

It only makes sense to activate this function if the dynamic response requirements of the speed controller are low.

In order to avoid oscillations, if required, the speed controller parameters should be adapted (increase Tn, reduce Kp). Further, the smoothing time of the flux setpoint filter (p1582) should be increased.

p1402[0...n]

Closed-loop current control and motor model configuration / I_ctrl config

Access level: 4	Calculated: p0340 = 1,3	Data type: Unsigned16
Can be changed: U, T	Scaling: -	Dyn. index: DDS, p0180
Unit group: -	Unit selection: -	Func. diagram: -
Min	Max	Factory setting
-	-	0000 0000 0000 0000 bin

Description:

Sets the configuration for the closed-loop control and the motor model.

Bit field:

Bit	Signal name	1 signal	0 signal	FP
02	Current controller adaptation active	Yes	No	-
13	Current controller decoupling filter	Yes	No	-

r1406.4...15		CO/BO: Control word speed controller / STW n_ctrl			
Access level: 3		Calculated: -	Data type: Unsigned16		
Can be changed: -		Scaling: -	Dyn. index: -		
Unit group: -		Unit selection: -	Func. diagram: 2520		
Min		Max	Factory setting		
-		-	-		
Description:	Display and BICO output for the control word of the speed controller.				
Bit field:	Bit	Signal name	1 signal	0 signal	FP
	04	Hold speed controller I component	Yes	No	6040
	05	Set speed controller I component	Yes	No	6040
	11	Droop enable	Yes	No	6030
	12	Torque control active	Yes	No	6060
	15	Set speed adaptation controller I component	Yes	No	-

r1407.0...27		CO/BO: Status word speed controller / ZSW n_ctrl			
Access level: 3		Calculated: -	Data type: Unsigned32		
Can be changed: -		Scaling: -	Dyn. index: -		
Unit group: -		Unit selection: -	Func. diagram: 2522		
Min		Max	Factory setting		
-		-	-		
Description:	Display and BICO output for the status word of the speed controller.				
Bit field:	Bit	Signal name	1 signal	0 signal	FP
	00	U/f control active	Yes	No	-
	01	Encoderless operation active	Yes	No	-
	02	Torque control active	Yes	No	6030, 6060, 8011
	03	Speed control active	Yes	No	6040
	05	Speed controller I component frozen	Yes	No	6040
	06	Speed controller I component set	Yes	No	6040
	07	Torque limit reached	Yes	No	6060
	08	Upper torque limit active	Yes	No	6060
	09	Lower torque limit active	Yes	No	6060
	10	Droop enabled	Yes	No	6030
	11	Speed setpoint limited	Yes	No	6030
	12	Ramp-function generator set	Yes	No	-
	13	Encoderless operation due to a fault	Yes	No	-
	14	U/f control active	Yes	No	-
	15	Torque limit reached (without precontrol)	Yes	No	6060
	17	Speed limiting control active	Yes	No	6640
	23	Acceleration model activated	Yes	No	-
	24	Moment of inertia estimator active	Yes	No	-
	25	Load estimate active	Yes	No	-
	26	Moment of inertia estimator stabilized	Yes	No	-
	27	Moment of inertia estimator fast estimation active	Yes	No	-

r1408.0...14		CO/BO: Status word current controller / ZSW I_ctrl		
Access level: 4		Calculated: -	Data type: Unsigned16	
Can be changed: -		Scaling: -	Dyn. index: -	
Unit group: -		Unit selection: -	Func. diagram: 2530	
Min		Max	Factory setting	
-		-	-	
Description:	Display and BICO output for the status word of the current controller.			

2 Parameters

2.2 List of parameters

Bit field:	Bit	Signal name	1 signal	0 signal	FP
	00	Current controller active	Active	Not active	-
	01	Id control I component limiting	Active	Not active	6714
	03	Voltage limiting	Active	Not active	6714
	10	Speed adaptation limiting	Active	Not active	-
	12	Motor stalled	Yes	No	-
	13	Separately excited synchronous motor is excited	Yes	No	-
	14	Current model SESM magnetizing excit. current limited to zero	Yes	No	-

p1416[0...n]	Speed setpoint filter 1 time constant / n_set_filt 1 T	
Access level: 4	Calculated: -	Data type: FloatingPoint32
Can be changed: U, T	Scaling: -	Dyn. index: DDS, p0180
Unit group: -	Unit selection: -	Func. diagram: 6020, 6030
Min	Max	Factory setting
0.00 [ms]	5000.00 [ms]	0.00 [ms]
Description:	Sets the time constant for the speed setpoint filter 1 (PT1).	

r1438	CO: Speed controller speed setpoint / n_ctrl n_set	
Access level: 3	Calculated: -	Data type: FloatingPoint32
Can be changed: -	Scaling: p2000	Dyn. index: -
Unit group: 3_1	Unit selection: p0505	Func. diagram: 3001, 6020, 6031
Min	Max	Factory setting
- [rpm]	- [rpm]	- [rpm]
Description:	Display and connector output of the speed setpoint after setpoint limiting for the P component of the speed controller. For U/f operation, the value that is displayed is of no relevance.	
Dependency:	Refer to: r1439	
Note:	In the standard state (the reference model is deactivated), r1438 = r1439.	

r1439	Speed setpoint I component / n_set I_comp	
Access level: 4	Calculated: -	Data type: FloatingPoint32
Can be changed: -	Scaling: p2000	Dyn. index: -
Unit group: 3_1	Unit selection: p0505	Func. diagram: 5030, 5040, 6031
Min	Max	Factory setting
- [rpm]	- [rpm]	- [rpm]
Description:	Displays the speed setpoint for the I component of the speed controller (output of the reference model after the setpoint limiting).	
Dependency:	Refer to: r1438	
Note:	In the standard state (the reference model is deactivated), r1438 = r1439.	

r1444	Speed controller speed setpoint steady-state (static) / n_ctrl n_set stat	
Access level: 4	Calculated: -	Data type: FloatingPoint32
Can be changed: -	Scaling: p2000	Dyn. index: -
Unit group: 3_1	Unit selection: p0505	Func. diagram: 5030
Min	Max	Factory setting
- [rpm]	- [rpm]	- [rpm]
Description:	Displays the sum of all speed setpoints that are present. The following sources are available for the displayed setpoint:	
	- setpoint at the ramp-function generator input (r1119).	
	- speed setpoint 1 (p1155).	
	- speed setpoint 2 (p1160).	
	- speed setpoint for the speed precontrol (p1430).	
	- setpoint from DSC (for DSC active).	
	- setpoint via PC (for master control active).	

Dependency: Refer to: r1119, p1155, p1160

r1445	CO: Actual speed smoothed / n_act smooth		
	Access level: 4	Calculated: -	Data type: FloatingPoint32
	Can be changed: -	Scaling: p2000	Dyn. index: -
	Unit group: 3_1	Unit selection: p0505	Func. diagram: 6040
	Min	Max	Factory setting
	- [rpm]	- [rpm]	- [rpm]

Description: Display and connector output for the actual smoothed speed actual value of the speed control.

p1452[0...n]	Speed controller speed actual value smoothing time (sensorless) / n_C n_act T_s SL		
	Access level: 2	Calculated: -	Data type: FloatingPoint32
	Can be changed: U, T	Scaling: -	Dyn. index: DDS, p0180
	Unit group: -	Unit selection: -	Func. diagram: 6020, 6040
	Min	Max	Factory setting
	0.00 [ms]	32000.00 [ms]	10.00 [ms]

Description: Sets the smoothing time for the actual speed of the speed controller for encoderless closed-loop speed control.

Note: The smoothing must be increased if there is gear backlash. For longer smoothing times, the integral time of the speed controller must also be increased (e.g. using p0340 = 4).

r1454	CO: Speed controller system deviation I component / n_ctrl sys dev Tn		
	Access level: 4	Calculated: -	Data type: FloatingPoint32
	Can be changed: -	Scaling: p2000	Dyn. index: -
	Unit group: 3_1	Unit selection: p0505	Func. diagram: 6040
	Min	Max	Factory setting
	- [rpm]	- [rpm]	- [rpm]

Description: Display and connector output for the system deviation of the I component of the speed controller.

p1455[0...n]	CI: Speed controller P gain adaptation signal / n_ctr adapt_sig Kp		
	Access level: 4	Calculated: -	Data type: U32 / FloatingPoint32
	Can be changed: T	Scaling: PERCENT	Dyn. index: CDS, p0170
	Unit group: -	Unit selection: -	Func. diagram: 6050
	Min	Max	Factory setting
	-	-	0

Description: Sets the source for the adaptation signal to additionally adapt the P gain of the speed controller.

Dependency: Refer to: p1456, p1457, p1458, p1459

p1456[0...n]	Speed controller P gain adaptation lower starting point / n_ctrl AdaptKpLow		
	Access level: 4	Calculated: -	Data type: FloatingPoint32
	Can be changed: U, T	Scaling: -	Dyn. index: DDS, p0180
	Unit group: -	Unit selection: -	Func. diagram: 6050
	Min	Max	Factory setting
	0.00 [%]	400.00 [%]	0.00 [%]

Description: Sets the lower starting point of the adaptation range for the additional adaptation of the P gain of the speed controller. The values are in % and refer to the set source of the adaptation signal.

Dependency: Refer to: p1455, p1457, p1458, p1459

Note: If the upper transition point p1457 of the speed controller adaptation is set to lower values than the lower transition p1456, then the controller gain below p1457 is adapted with p1459 and above p1456, with p1458.

p1457[0...n]	Speed controller P gain adaptation upper starting point / n_ctrl AdaptKp up		
	Access level: 4	Calculated: -	Data type: FloatingPoint32
	Can be changed: U, T	Scaling: -	Dyn. index: DDS, p0180
	Unit group: -	Unit selection: -	Func. diagram: 6050
	Min	Max	Factory setting
	0.00 [%]	400.00 [%]	0.00 [%]
Description:	Sets the upper starting point of the adaptation range for the additional adaptation of the P gain of the speed controller. The values are in % and refer to the set source of the adaptation signal.		
Dependency:	Refer to: p1455, p1456, p1458, p1459		
Note:	If the upper transition point p1457 of the speed controller adaptation is set to lower values than the lower transition p1456, then the controller gain below p1457 is adapted with p1459 and above p1456, with p1458.		
p1458[0...n]	Adaptation factor lower / Adapt_factor lower		
	Access level: 4	Calculated: -	Data type: FloatingPoint32
	Can be changed: U, T	Scaling: -	Dyn. index: DDS, p0180
	Unit group: -	Unit selection: -	Func. diagram: 6050
	Min	Max	Factory setting
	0.0 [%]	200000.0 [%]	100.0 [%]
Description:	Sets the adaptation factor before the adaptation range (0 % ... p1456) to additionally adapt the P gain of the speed/velocity controller.		
Dependency:	Refer to: p1455, p1456, p1457, p1459		
Note:	If the upper transition point p1457 of the speed controller adaptation is set to lower values than the lower transition p1456, then the controller gain below p1457 is adapted with p1459 and above p1456, with p1458.		
p1459[0...n]	Adaptation factor upper / Adapt_factor upper		
	Access level: 4	Calculated: -	Data type: FloatingPoint32
	Can be changed: U, T	Scaling: -	Dyn. index: DDS, p0180
	Unit group: -	Unit selection: -	Func. diagram: 6050
	Min	Max	Factory setting
	0.0 [%]	200000.0 [%]	100.0 [%]
Description:	Sets the adaptation factor after the adaptation range (> p1457) to additionally adapt the P gain of the speed/velocity controller.		
Dependency:	Refer to: p1455, p1456, p1457, p1458		
Note:	If the upper transition point p1457 of the speed controller adaptation is set to lower values than the lower transition p1456, then the controller gain below p1457 is adapted with p1459 and above p1456, with p1458.		
p1461[0...n]	Speed controller Kp adaptation speed upper scaling / n_ctr Kp n up scal		
	Access level: 3	Calculated: p0340 = 1,3,4	Data type: FloatingPoint32
	Can be changed: U, T	Scaling: -	Dyn. index: DDS, p0180
	Unit group: -	Unit selection: -	Func. diagram: 6050
	Min	Max	Factory setting
	0.0 [%]	200000.0 [%]	100.0 [%]
Description:	Sets the P gain of the speed controller for the upper adaptation speed range (> p1465). The entry is made referred to the P gain for the lower adaptation speed range of the speed controller (% referred to p1470).		
Dependency:	Refer to: p1464, p1465		
Note:	If the upper transition point p1465 of the speed controller adaptation is set to lower values than the lower transition p1464, then the controller gain below p1465 is adapted with p1461. This means that an adaptation can be implemented for low speeds without having to change the controller parameters.		

p1463[0...n]	Speed controller Tn adaptation speed upper scaling / n_ctr Tn n up scal		
	Access level: 3	Calculated: p0340 = 1,3,4	Data type: FloatingPoint32
	Can be changed: U, T	Scaling: -	Dyn. index: DDS, p0180
	Unit group: -	Unit selection: -	Func. diagram: 6050
	Min	Max	Factory setting
	0.0 [%]	200000.0 [%]	100.0 [%]
Description:	Sets the integral time of the speed controller after the adaptation speed range (> p1465). The entry is made referred to the integral time for the lower adaptation speed range of the speed controller (% referred to p1472).		
Dependency:	Refer to: p1464, p1465		
Note:	If the upper transition point p1465 of the speed controller adaptation is set to lower values than the lower transition point p1464, then the controller integral time below p1465 is adapted with p1463. This means that an adaptation can be implemented for low speeds without having to change the controller parameters.		
p1464[0...n]	Speed controller adaptation speed lower / n_ctrl n lower		
	Access level: 3	Calculated: p0340 = 1,3,4	Data type: FloatingPoint32
	Can be changed: U, T	Scaling: -	Dyn. index: DDS, p0180
	Unit group: 3_1	Unit selection: p0505	Func. diagram: 6050
	Min	Max	Factory setting
	0.00 [rpm]	210000.00 [rpm]	0.00 [rpm]
Description:	Sets the lower adaptation speed of the speed controller. No adaptation is effective below this speed.		
Dependency:	Refer to: p1461, p1463, p1465		
Note:	If the upper transition point p1465 of the speed controller adaptation is set to lower values than the lower transition point p1464, then the controller below p1465 is adapted with p1461 or p1463. This means that an adaptation can be implemented for low speeds without having to change the controller parameters.		
p1465[0...n]	Speed controller adaptation speed upper / n_ctrl n upper		
	Access level: 3	Calculated: p0340 = 1,3,4	Data type: FloatingPoint32
	Can be changed: U, T	Scaling: -	Dyn. index: DDS, p0180
	Unit group: 3_1	Unit selection: p0505	Func. diagram: 6050
	Min	Max	Factory setting
	0.00 [rpm]	210000.00 [rpm]	210000.00 [rpm]
Description:	Sets the upper adaptation speed of the speed controller. No adaptation is effective above this speed. For the proportional gain, p1470 x p1461 is effective. For the integral time, p1472 x p1463 is effective.		
Dependency:	Refer to: p1461, p1463, p1464		
Note:	If the upper transition point p1465 of the speed controller adaptation is set to lower values than the lower transition point p1464, then the controller below p1465 is adapted with p1461 or p1463. This means that an adaptation can be implemented for low speeds without having to change the controller parameters.		
p1466[0...n]	CI: Speed controller P-gain scaling / n_ctrl Kp scal		
	Access level: 4	Calculated: -	Data type: U32 / FloatingPoint32
	Can be changed: T	Scaling: PERCENT	Dyn. index: CDS, p0170
	Unit group: -	Unit selection: -	Func. diagram: 6050
	Min	Max	Factory setting
	-	-	1
Description:	Sets the signal source for the scaling of the P gain of the speed controller. This also makes the effective P gain (including adaptations) scalable.		

r1468	CO: Speed controller P-gain effective / n_ctr Kp eff	Access level: 4 Can be changed: - Unit group: - Min -	Calculated: - Scaling: - Unit selection: - Max -	Data type: FloatingPoint32 Dyn. index: - Func. diagram: 6040 Factory setting -
Description:	Displays the effective P gain of the speed controller.			
Dependency:	The connector output signal r1468 is increased by a factor of 100 in order to improve the resolution.			
r1469	Speed controller integral time effective / n_ctr Tn eff	Access level: 4 Can be changed: - Unit group: - Min - [ms]	Calculated: - Scaling: - Unit selection: - Max - [ms]	Data type: FloatingPoint32 Dyn. index: - Func. diagram: 5040, 5042, 6040 Factory setting - [ms]
Description:	Displays the effective integral time of the speed controller.			
p1470[0...n]	Speed controller encoderless operation P-gain / n_ctrl SL Kp	Access level: 2 Can be changed: U, T Unit group: - Min 0.000	Calculated: p0340 = 1,3,4 Scaling: - Unit selection: - Max 999999.000	Data type: FloatingPoint32 Dyn. index: DDS, p0180 Func. diagram: 6040, 6050 Factory setting 0.300
Description:	Sets the P gain for encoderless operation for the speed controller.			
Note:	The product p0341 x p0342 is taken into account when automatically calculating the speed controller (p0340 = 1, 3, 4).			
p1472[0...n]	Speed controller encoderless operation integral time / n_ctrl SL Tn	Access level: 2 Can be changed: U, T Unit group: - Min 0.0 [ms]	Calculated: p0340 = 1,3,4 Scaling: - Unit selection: - Max 100000.0 [ms]	Data type: FloatingPoint32 Dyn. index: DDS, p0180 Func. diagram: 6040, 6050 Factory setting 20.0 [ms]
Description:	Set the integral time for encoderless operation for the speed controller.			
Note:	The integral component is stopped if the complete controller output or the sum of controller output and torque precontrol reach the torque limit.			
p1475[0...n]	CI: Speed controller torque setting value for motor holding brake / n_ctrl M_sv MHB	Access level: 3 Can be changed: T Unit group: - Min -	Calculated: - Scaling: p2003 Unit selection: - Max -	Data type: U32 / FloatingPoint32 Dyn. index: CDS, p0170 Func. diagram: 6040 Factory setting 0
Description:	Sets the signal source for the torque setting value when starting up with motor holding brake.			
Recommendation:	To hold the actual torque when stopping the motor, you are advised to set p1400 bit 1 = 1. As a result, the integral component of the speed controller is frozen when changing to the open-loop controlled operating range.			
Dependency:	The switching in of the torque setting value for the motor holding brake has a higher priority than the setting of the integrator value using p1477 and p1478.			
Note:	The setting of the integral output of the speed controller begins after magnetizing (see p0346, r0056 bit 4) and ends at the end of the brake control opening time p1216. A setting value of zero means that no setting procedure will take place. If p1351 is used as a signal source for the torque setting value, the percentage value is interpreted in relation to the rated torque (p2003).			

p1476[0...n]	BI: Speed controller hold integrator / n_ctrl integ stop		
	Access level: 4	Calculated: -	Data type: U32 / Binary
	Can be changed: T	Scaling: -	Dyn. index: CDS, p0170
	Unit group: -	Unit selection: -	Func. diagram: 2520, 6040
	Min	Max	Factory setting
	-	-	0
Description:	Sets the signal source to hold the integrator for the speed controller.		
p1477[0...n]	BI: Speed controller set integrator value / n_ctrl integ set		
	Access level: 3	Calculated: -	Data type: U32 / Binary
	Can be changed: T	Scaling: -	Dyn. index: CDS, p0170
	Unit group: -	Unit selection: -	Func. diagram: 2520, 6040
	Min	Max	Factory setting
	-	-	0
Description:	Sets the signal source to set the integrator setting value (p1478).		
Dependency:	Refer to: p1478, p1479		
Notice:	The parameter may be protected as a result of p0922 or p2079 and cannot be changed.		
p1478[0...n]	CI: Speed controller integrator setting value / n_ctr integ_setVal		
	Access level: 3	Calculated: -	Data type: U32 / FloatingPoint32
	Can be changed: T	Scaling: p2003	Dyn. index: CDS, p0170
	Unit group: -	Unit selection: -	Func. diagram: 6040
	Min	Max	Factory setting
	-	-	0
Description:	Sets the signal source for the integrator setting value for the velocity controller. The signal to set this integrator setting value is interconnected via p1477.		
Dependency:	The setting value of the speed controller integrator is weighted with the scaling factor of the signal source in p1479. If p1478 is interconnected to the integral output of the speed controller (r1482), then after the magnetizing time (r0346) and if the speed controller is enabled, the integral component of the controller is set to the last value before the pulse inhibit. This value is set if no setting command (p1477) is interconnected or, at the instant that the pulses were inhibited, a setting command is available, which is not deactivated up to the next time that the pulses are inhibited. For sensorless vector control, in addition p1400.1 should be set to 1 so that when the drive is stopped, the integral component of the speed controller is not controlled down to zero. In order that when setting the integrator output, only the static torque is detected, we recommend that the accelerating torque is completely precontrolled (e.g. p1496). If p1478 is interconnected to another output other than r1482, then after magnetizing and speed controller enable, the integral output is set once if the setting command is not interconnected (p1477 = 0). Refer to: p1477, p1479		
Notice:	The parameter may be protected as a result of p0922 or p2079 and cannot be changed.		
p1479[0...n]	CI: Speed controller integrator setting value scaling / n_ctrl I_val scal		
	Access level: 4	Calculated: -	Data type: U32 / FloatingPoint32
	Can be changed: T	Scaling: PERCENT	Dyn. index: CDS, p0170
	Unit group: -	Unit selection: -	Func. diagram: 6040
	Min	Max	Factory setting
	-	-	1
Description:	Sets the signal source for scaling the integrator setting value (p1478) of the speed controller.		
Dependency:	Refer to: p1477, p1478		

r1482	CO: Speed controller I torque output / n_ctrl I-M_outp	Access level: 3 Can be changed: - Unit group: 7_1 Min - [Nm]	Calculated: - Scaling: p2003 Unit selection: p0505 Max - [Nm]	Data type: FloatingPoint32 Dyn. index: - Func. diagram: 5040, 5042, 5210, 6030, 6040 Factory setting - [Nm]
Description:	Display and connector output for the torque setpoint at the output of the I speed controller.			
p1486[0...n]	CI: Droop compensation torque / Droop M_comp	Access level: 3 Can be changed: T Unit group: - Min -	Calculated: - Scaling: p2003 Unit selection: - Max -	Data type: U32 / FloatingPoint32 Dyn. index: CDS, p0170 Func. diagram: 6030 Factory setting 0
Description:	Sets the signal source for the compensation torque to be output within the droop calculation. This parameter should be interconnected with the torque setpoint of the drive (corresponding to the selection p1488), with which load equalization should be performed.			
p1487[0...n]	Droop compensation torque scaling / Droop M_comp scal	Access level: 3 Can be changed: U, T Unit group: - Min -2000.0 [%]	Calculated: - Scaling: PERCENT Unit selection: - Max 2000.0 [%]	Data type: FloatingPoint32 Dyn. index: DDS, p0180 Func. diagram: 6030 Factory setting 100.0 [%]
Description:	Sets the scaling for the compensation torque within the droop calculation.			
p1488[0...n]	Droop input source / Droop input source	Access level: 3 Can be changed: U, T Unit group: - Min 0	Calculated: - Scaling: - Unit selection: - Max 3	Data type: Integer16 Dyn. index: DDS, p0180 Func. diagram: 6030 Factory setting 0
Description:	Sets the source for droop feedback. With increasing torque, the speed setpoint is reduced (enabled using p1492), so that for mechanically coupled drives a load equalization (load compensation) is obtained. A load difference compensation is also possible, if p1486 is interconnected with the torque setpoint of the other drive.			
Value:	0: Droop feedback not connected 1: Droop from torque setpoint 2: Droop from speed controller output 3: Droop from integral output speed controller			
Dependency:	Refer to: p1486, p1487, p1489, r1490, p1492			
Caution:	For active acceleration precontrol of the speed controller (refer to p1496), it is not recommended that p1488 is set to 1, as this could result in positive coupling effects. Instead of this, as source of the droop feedback, the output signal of the speed controller should be used, which generally sets the load torque.			
				
p1489[0...n]	Droop feedback scaling / Droop scal	Access level: 3 Can be changed: U, T Unit group: - Min 0.000	Calculated: - Scaling: - Unit selection: - Max 0.500	Data type: FloatingPoint32 Dyn. index: DDS, p0180 Func. diagram: 6030 Factory setting 0.050
Description:	Sets the scaling for the droop feedback			

Dependency: Refer to: p1486, p1487, p1488, r1490, p1492
Note: Example:
 A value of 0.05 means that for a torque equal to the rated motor torque, the rated motor speed is reduced by 5 %.

r1490	CO: Droop feedback speed reduction / Droop n_reduction		
	Access level: 3	Calculated: -	Data type: FloatingPoint32
	Can be changed: -	Scaling: p2000	Dyn. index: -
	Unit group: 3_1	Unit selection: p0505	Func. diagram: 6030
	Min	Max	Factory setting
	- [rpm]	- [rpm]	- [rpm]

Description: Displays the output signal of the droop calculation.
 The droop feedback result is subtracted from the speed setpoint when activated (p1492).

Dependency: Refer to: p1486, p1487, p1488, p1489, p1492

p1492[0...n]	BI: Droop feedback enable / Droop enable		
	Access level: 3	Calculated: -	Data type: U32 / Binary
	Can be changed: U, T	Scaling: -	Dyn. index: CDS, p0170
	Unit group: -	Unit selection: -	Func. diagram: 2520, 6030
	Min	Max	Factory setting
	-	-	0

Description: Enables the droop to be applied to the speed/velocity setpoint.

Dependency: Refer to: p1486, p1487, p1488, p1489, r1490

Note: Even when not enabled, the droop speed is calculated but not subtracted from the setpoint speed. This makes it possible to subtract the result of this calculation from the speed of another drive.

r1493	CO: Moment of inertia total, scaled / M_inert tot scal		
	Access level: 3	Calculated: -	Data type: FloatingPoint32
	Can be changed: -	Scaling: -	Dyn. index: -
	Unit group: 25_1	Unit selection: p0100	Func. diagram: 6031
	Min	Max	Factory setting
	- [kgm ²]	- [kgm ²]	- [kgm ²]

Description: Display and connector output for the parameterized total moment of inertia.
 The value is calculated as follows: (p0341 * p0342) * p1496

p1496[0...n]	Acceleration precontrol scaling / a_prectrl scal		
	Access level: 3	Calculated: -	Data type: FloatingPoint32
	Can be changed: U, T	Scaling: -	Dyn. index: DDS, p0180
	Unit group: -	Unit selection: -	Func. diagram: 6020, 6031
	Min	Max	Factory setting
	0.0 [%]	10000.0 [%]	0.0 [%]

Description: Sets the scaling for the acceleration precontrol of the speed/velocity controller.

Dependency: Refer to: p0341, p0342

Warning:  The acceleration precontrol r1518 is kept at the old value if the ramp-function generator tracking (r1199.5) is active or the ramp-function generator output is set (r1199.3). This is used to avoid torque peaks. Depending on the application, it may therefore be necessary to disable the ramp-function generator tracking (p1145 = 0) or the acceleration precontrol (p1496 = 0).

The acceleration precontrol is set to zero, if the Vdc control is active (r0056.14/15).

Note: The parameter is set to 100% by the rotating measurement (refer to p1960).

The acceleration precontrol may not be used if the speed setpoint manifests significant ripple (e.g. analog setpoint) and the rounding-off in the speed ramp-function generator is disabled.

We also recommend that the precontrol mode is not used if there is gearbox backlash.

p1499[0...n]	Accelerating for torque control scaling / a for M_ctrl scal		
	Access level: 3	Calculated: -	Data type: FloatingPoint32
	Can be changed: U, T	Scaling: -	Dyn. index: DDS, p0180
	Unit group: -	Unit selection: -	Func. diagram: 6030
	Min	Max	Factory setting
	0.0 [%]	400.0 [%]	100.0 [%]
Description:	Sets the scaling for the acceleration integrator at low speeds (only for encoderless torque control).		
Dependency:	Refer to: p0341, p0342		
p1500[0...n]	Torque setpoint selection / M_set sel		
	Access level: 2	Calculated: -	Data type: Integer16
	Can be changed: C(1), T	Scaling: -	Dyn. index: CDS, p0170
	Unit group: -	Unit selection: -	Func. diagram: -
	Min	Max	Factory setting
	0	66	0
Description:	Sets the source for the torque setpoint. For single-digit values, the following applies: The value specifies the main setpoint. For double-digit values, the following applies: The left-hand digit specifies the supplementary setpoint, the right-hand digit the main setpoint. Example: Value = 26 --> The analog setpoint (2) supplies the supplementary setpoint. --> The fieldbus (6) supplies the main setpoint.		
Value:	0: No main setpoint 2: Analog setpoint 6: Fieldbus 20: Analog setpoint + no main setpoint 22: Analog setpoint + analog setpoint 26: Analog setpoint + fieldbus 60: Fieldbus + no main setpoint 62: Fieldbus + analog setpoint 66: Fieldbus+fieldbus		
Dependency:	When changing this parameter, the following settings are influenced: Refer to: p1503, p1511		
Notice:	When executing a specific macro, the corresponding programmed settings are made and become active.		
p1501[0...n]	BI: Change over between closed-loop speed/torque control / Changeov n/M_ctrl		
	Access level: 3	Calculated: -	Data type: U32 / Binary
	Can be changed: U, T	Scaling: -	Dyn. index: CDS, p0170
	Unit group: -	Unit selection: -	Func. diagram: 2520, 6020
	Min	Max	Factory setting
	-	-	0
Description:	Sets the signal source for toggling between speed and torque control. 0 signal: Closed-loop speed control 1 signal: Closed-loop torque control		
Dependency:	The input connectors to enter the torque are provided using p1511, p1512 and p1513. Refer to: p1300		
Notice:	If the closed-loop torque control is not activated (p1300) and a change is made to closed-loop torque control (p1501), OFF1 (p0840) does not have its own braking response but pulse cancellation when standstill is detected (p1226, p1227).		
Note:	The parameter may be protected as a result of p0922 or p2079 and cannot be changed.		

p1502[0...n]	BI: Freeze moment of inertia estimator / J_estim freeze		
	Access level: 3	Calculated: -	Data type: U32 / Binary
	Can be changed: U, T	Scaling: -	Dyn. index: CDS, p0170
	Unit group: -	Unit selection: -	Func. diagram: -
	Min	Max	Factory setting
	-	-	0
Description:	Sets the signal source to freeze the estimated moment of inertia. 0 signal: Moment of inertia estimator active 1 signal: Determined moment of inertia frozen.		
Dependency:	Refer to: p1300		
Note:	Only active when the "moment of inertia estimator" function module is active (r0108.10 = 1) and p1400.18 = 1.		
p1503[0...n]	CI: Torque setpoint / M_set		
	Access level: 3	Calculated: -	Data type: U32 / FloatingPoint32
	Can be changed: T	Scaling: p2003	Dyn. index: CDS, p0170
	Unit group: -	Unit selection: -	Func. diagram: 6020, 6060
	Min	Max	Factory setting
	-	-	0
Description:	Sets the signal source for the torque setpoint for torque control.		
Note:	A change is made to closed-loop torque control if, in p1300, closed-loop torque control was selected or if the selection was made using the changeover source in p1501. it is also possible to change over in operation using p1501.		
r1508	CO: Torque setpoint before supplementary torque / M_set bef. M_suppl		
	Access level: 2	Calculated: -	Data type: FloatingPoint32
	Can be changed: -	Scaling: p2003	Dyn. index: -
	Unit group: 7_1	Unit selection: p0505	Func. diagram: 6030, 6060, 6722
	Min	Max	Factory setting
	- [Nm]	- [Nm]	- [Nm]
Description:	Displays the torque setpoint before entering the supplementary torque. For closed-loop speed control, r1508 corresponds to the speed controller output; for closed-loop torque control, r1508 corresponds to the torque setpoint of the signal source assigned in p1503.		
p1511[0...n]	CI: Supplementary torque 1 / M_suppl 1		
	Access level: 3	Calculated: -	Data type: U32 / FloatingPoint32
	Can be changed: T	Scaling: p2003	Dyn. index: CDS, p0170
	Unit group: -	Unit selection: -	Func. diagram: 6020, 6060
	Min	Max	Factory setting
	-	-	0
Description:	Sets the signal source for supplementary torque 1.		
p1512[0...n]	CI: Supplementary torque 1 scaling / M_suppl 1 scal		
	Access level: 3	Calculated: -	Data type: U32 / FloatingPoint32
	Can be changed: T	Scaling: PERCENT	Dyn. index: CDS, p0170
	Unit group: -	Unit selection: -	Func. diagram: 5060, 6060
	Min	Max	Factory setting
	-	-	0
Description:	Sets the signal source for scaling the supplementary torque 1.		

p1513[0...n]	CI: Supplementary torque 2 / M_suppl 2		
	Access level: 3	Calculated: -	Data type: U32 / FloatingPoint32
	Can be changed: T	Scaling: p2003	Dyn. index: CDS, p0170
	Unit group: -	Unit selection: -	Func. diagram: 6020, 6060
	Min	Max	Factory setting
	-	-	0
Description:	Sets the signal source for supplementary torque 2.		

p1514[0...n]	Supplementary torque 2 scaling / M_suppl 2 scal		
	Access level: 3	Calculated: -	Data type: FloatingPoint32
	Can be changed: U, T	Scaling: PERCENT	Dyn. index: DDS, p0180
	Unit group: -	Unit selection: -	Func. diagram: 6020, 6060
	Min	Max	Factory setting
	-2000.0 [%]	2000.0 [%]	100.0 [%]
Description:	Sets the scaling for supplementary torque 2.		

r1515	Supplementary torque total / M_suppl total		
	Access level: 2	Calculated: -	Data type: FloatingPoint32
	Can be changed: -	Scaling: p2003	Dyn. index: -
	Unit group: 7_1	Unit selection: p0505	Func. diagram: 6020, 6060
	Min	Max	Factory setting
	- [Nm]	- [Nm]	- [Nm]
Description:	Displays the total supplementary torque. The displayed value is the total of supplementary torque values 1 and 2 (p1511, p1512, p1513, p1514).		

r1516	CO: Supplementary torque and acceleration torque / M_suppl + M_accel		
	Access level: 2	Calculated: -	Data type: FloatingPoint32
	Can be changed: -	Scaling: p2003	Dyn. index: -
	Unit group: 7_1	Unit selection: p0505	Func. diagram: 6060
	Min	Max	Factory setting
	- [Nm]	- [Nm]	- [Nm]
Description:	Displays the total supplementary torque and the accelerating torque. The displayed value is the total of the smoothed supplementary torque and the accelerating torque (p1516 = p1518[1] + r1515).		

p1517[0...n]	Accelerating torque smoothing time constant / M_accel T_smooth		
	Access level: 4	Calculated: -	Data type: FloatingPoint32
	Can be changed: U, T	Scaling: -	Dyn. index: DDS, p0180
	Unit group: -	Unit selection: -	Func. diagram: 6060
	Min	Max	Factory setting
	0.00 [ms]	100.00 [ms]	4.00 [ms]
Description:	Sets the smoothing time constant of the accelerating torque.		
Note:	The acceleration precontrol is inhibited if the smoothing is set to the maximum value.		

r1518[0...1]	CO: Accelerating torque / M_accel		
	Access level: 3	Calculated: -	Data type: FloatingPoint32
	Can be changed: -	Scaling: p2003	Dyn. index: -
	Unit group: 7_1	Unit selection: p0505	Func. diagram: 6060
	Min	Max	Factory setting
	- [Nm]	- [Nm]	- [Nm]
Description:	Displays the accelerating torque for precontrol of the speed controller.		

Index: [0] = Unsmoothed
[1] = Smoothed

Dependency: Refer to: p0341, p0342, p1496

p1520[0...n]	CO: Torque limit upper / M_max upper		
Access level: 2	Calculated: p0340 = 1,3,5	Data type: FloatingPoint32	
Can be changed: U, T	Scaling: p2003	Dyn. index: DDS, p0180	
Unit group: 7_1	Unit selection: p0505	Func. diagram: 6020, 6630	
Min	Max	Factory setting	
-1000000.00 [Nm]	20000000.00 [Nm]	0.00 [Nm]	

Description: Sets the fixed, upper torque limit.

Dependency: Refer to: p1521, p1522, p1523, r1538, r1539

Danger: Negative values when setting the upper torque limit (p1520 < 0) can result in the motor accelerating in an uncontrollable fashion.



Notice: A BICO interconnection to a parameter that belongs to a drive data set always acts on the effective data set.

Note: The torque limit is limited to 400% of the rated motor torque. When automatically calculating the motor/closed-loop control parameters (p0340), the torque limit is set to match the current limit (p0640).

p1521[0...n]	CO: Torque limit lower / M_max lower		
Access level: 2	Calculated: p0340 = 1,3,5	Data type: FloatingPoint32	
Can be changed: U, T	Scaling: p2003	Dyn. index: DDS, p0180	
Unit group: 7_1	Unit selection: p0505	Func. diagram: 6020, 6630	
Min	Max	Factory setting	
-20000000.00 [Nm]	1000000.00 [Nm]	0.00 [Nm]	

Description: Sets the fixed, lower torque limit.

Dependency: Refer to: p1520, p1522, p1523

Danger: Positive values when setting the lower torque limit (p1521 > 0) can result in the motor accelerating in an uncontrollable fashion.



Notice: A BICO interconnection to a parameter that belongs to a drive data set always acts on the effective data set.

Note: The torque limit is limited to 400% of the rated motor torque. When automatically calculating the motor/closed-loop control parameters (p0340), the torque limit is set to match the current limit (p0640).

p1522[0...n]	CI: Torque limit upper / M_max upper		
Access level: 3	Calculated: -	Data type: U32 / FloatingPoint32	
Can be changed: T	Scaling: p2003	Dyn. index: CDS, p0170	
Unit group: -	Unit selection: -	Func. diagram: 6630	
Min	Max	Factory setting	
-	-	1520[0]	

Description: Sets the signal source for the upper torque limit.

Dependency: Refer to: p1520, p1521, p1523

Danger: Negative values resulting from the signal source and scaling can cause the motor to accelerate in an uncontrolled manner.



p1523[0...n]	CI: Torque limit lower / M_max lower		
Access level: 3	Calculated: -	Data type: U32 / FloatingPoint32	
Can be changed: T	Scaling: p2003	Dyn. index: CDS, p0170	
Unit group: -	Unit selection: -	Func. diagram: 6020, 6630	
Min	Max	Factory setting	
-	-	1521[0]	

Description: Sets the signal source for the lower torque limit.

Dependency: Refer to: p1520, p1521, p1522

Danger: Positive values resulting from the signal source and scaling can cause the motor to accelerate in an uncontrolled manner.



p1524[0...n]	CO: Torque limit upper scaling / M_max upper scal		
Access level: 3	Calculated: -	Data type: FloatingPoint32	
Can be changed: U, T	Scaling: PERCENT	Dyn. index: DDS, p0180	
Unit group: -	Unit selection: -	Func. diagram: 6630	
Min	Max	Factory setting	
-2000.0 [%]	2000.0 [%]	100.0 [%]	

Description: Sets the scaling for the upper torque limit.
Notice: A BICO interconnection to a parameter that belongs to a drive data set always acts on the effective data set.
Note: This parameter can be freely interconnected.
 The value has the meaning stated above if it is interconnected from connector input p1528.

p1525[0...n]	CO: Torque limit lower scaling / M_max lower scal		
Access level: 3	Calculated: -	Data type: FloatingPoint32	
Can be changed: U, T	Scaling: PERCENT	Dyn. index: DDS, p0180	
Unit group: -	Unit selection: -	Func. diagram: 6630	
Min	Max	Factory setting	
-2000.0 [%]	2000.0 [%]	100.0 [%]	

Description: Sets the scaling for the lower torque limit.
Notice: A BICO interconnection to a parameter that belongs to a drive data set always acts on the effective data set.
Note: This parameter can be freely interconnected.
 The value has the meaning stated above if it is interconnected from connector input p1528.

r1526	CO: Torque limit upper without offset / M_max up w/o offs		
Access level: 3	Calculated: -	Data type: FloatingPoint32	
Can be changed: -	Scaling: p2003	Dyn. index: -	
Unit group: 7_1	Unit selection: p0505	Func. diagram: 6060, 6630, 6640	
Min	Max	Factory setting	
- [Nm]	- [Nm]	- [Nm]	

Description: Display and connector output for the upper torque limit of all torque limits without offset.
Dependency: Refer to: p1520, p1521, p1522, p1523, p1528, p1529

r1527	CO: Torque limit lower without offset / M_max low w/o offs		
Access level: 3	Calculated: -	Data type: FloatingPoint32	
Can be changed: -	Scaling: p2003	Dyn. index: -	
Unit group: 7_1	Unit selection: p0505	Func. diagram: 6060, 6630, 6640	
Min	Max	Factory setting	
- [Nm]	- [Nm]	- [Nm]	

Description: Display and connector output for the lower torque limit of all torque limits without offset.
Dependency: Refer to: p1520, p1521, p1522, p1523, p1528, p1529

p1528[0...n]	CI: Torque limit upper scaling / M_max upper scal		
Access level: 4	Calculated: -	Data type: U32 / FloatingPoint32	
Can be changed: T	Scaling: PERCENT	Dyn. index: CDS, p0170	
Unit group: -	Unit selection: -	Func. diagram: 6630	
Min	Max	Factory setting	
-	-	1524[0]	

Description: Sets the signal source for the scaling of the upper torque limit in p1522.
Danger: For p1400.4 = 0 (torque limiting, upper/lower) the following applies:
 Negative values resulting from the signal source and scaling can cause the motor to accelerate in an uncontrolled manner.



Notice: The parameter may be protected as a result of p0922 or p2079 and cannot be changed.

p1529[0...n]	Cl: Torque limit lower scaling / M_max lower scal		
Access level: 4	Calculated: -	Data type: U32 / FloatingPoint32	
Can be changed: T	Scaling: PERCENT	Dyn. index: CDS, p0170	
Unit group: -	Unit selection: -	Func. diagram: 6630	
Min	Max	Factory setting	
-	-	1525[0]	

Description: Sets the signal source for the scaling of the lower torque limit in p1523.

Danger: For p1400.4 = 0 (torque limiting, upper/lower) the following applies:



Positive values resulting from the signal source and scaling can cause the motor to accelerate in an uncontrolled manner.

Notice: The parameter may be protected as a result of p0922 or p2079 and cannot be changed.

p1530[0...n]	Power limit motoring / P_max mot		
Access level: 2	Calculated: p0340 = 1,3,5	Data type: FloatingPoint32	
Can be changed: U, T	Scaling: -	Dyn. index: DDS, p0180	
Unit group: 14_5	Unit selection: p0505	Func. diagram: 6640	
Min	Max	Factory setting	
0.00 [kW]	100000.00 [kW]	0.00 [kW]	

Description: Sets the power limit when motoring.

Dependency: Refer to: p0500, p1531

Note: The power limit is limited to 300% of the rated motor power.

p1531[0...n]	Power limit regenerative / P_max gen		
Access level: 2	Calculated: p0340 = 1,3,5	Data type: FloatingPoint32	
Can be changed: U, T	Scaling: -	Dyn. index: DDS, p0180	
Unit group: 14_5	Unit selection: p0505	Func. diagram: 6640	
Min	Max	Factory setting	
-100000.00 [kW]	-0.01 [kW]	-0.01 [kW]	

Description: Sets the regenerative power limit.

Dependency: Refer to: r0206, p0500, p1530

Note: The power limit is limited to 300% of the rated motor power.

For power units without energy recovery capability, the regenerative power limit is preset to 30 % of the power r0206[0]. For a braking resistor connected to the DC link (p0219 > 0), the power limit when generating is automatically adapted.

For power units with energy recovery, the parameter is limited to the negative value of r0206[2].

r1533	Current limit torque-generating total / Iq_max total		
Access level: 3	Calculated: -	Data type: FloatingPoint32	
Can be changed: -	Scaling: p2002	Dyn. index: -	
Unit group: 6_2	Unit selection: p0505	Func. diagram: 6640	
Min	Max	Factory setting	
- [Arms]	- [Arms]	- [Arms]	

Description: Displays the maximum torque/force generating current as a result if all current limits.

r1536[0...1]	Current limit maximum torque-generating current / Isq_max		
	Access level: 4	Calculated: -	Data type: FloatingPoint32
	Can be changed: -	Scaling: p2002	Dyn. index: -
	Unit group: 6_2	Unit selection: p0505	Func. diagram: 6640, 6710
	Min	Max	Factory setting
	- [Arms]	- [Arms]	- [Arms]
Description:	Displays the maximum limit for the torque-generating current component. Index 0 indicates the signal limited by the Vdc controller.		
Index:	[0] = Limited [1] = Unlimited		
r1537[0...1]	Current limit minimum torque-generating current / Isq_min		
	Access level: 4	Calculated: -	Data type: FloatingPoint32
	Can be changed: -	Scaling: p2002	Dyn. index: -
	Unit group: 6_2	Unit selection: p0505	Func. diagram: 6640, 6710
	Min	Max	Factory setting
	- [Arms]	- [Arms]	- [Arms]
Description:	Displays the minimum limit for the torque-generating current component. Index 0 indicates the signal limited by the Vdc controller.		
Index:	[0] = Limited [1] = Unlimited		
r1538	CO: Upper effective torque limit / M_max upper eff		
	Access level: 2	Calculated: -	Data type: FloatingPoint32
	Can be changed: -	Scaling: p2003	Dyn. index: -
	Unit group: 7_1	Unit selection: p0505	Func. diagram: 6020, 6640
	Min	Max	Factory setting
	- [Nm]	- [Nm]	- [Nm]
Description:	Display and connector output for the actual effective upper torque limit.		
Note:	The effective upper torque limit is reduced with respect to the selected upper torque limit p1520, if the current limit p0640 is reduced or the rated magnetizing current of the induction motor p0320 is increased. This may be the case for rotating measurements (see p1960). The torque limit p1520 can be re-calculated using p0340 = 1, 3 or 5.		
r1539	CO: Lower effective torque limit / M_max lower eff		
	Access level: 2	Calculated: -	Data type: FloatingPoint32
	Can be changed: -	Scaling: p2003	Dyn. index: -
	Unit group: 7_1	Unit selection: p0505	Func. diagram: 6020, 6640
	Min	Max	Factory setting
	- [Nm]	- [Nm]	- [Nm]
Description:	Display and connector output for the actual effective lower torque limit.		
Note:	The effective lower torque limit is reduced with respect to the selected lower torque limit p1521, if the current limit p0640 is reduced or the rated magnetizing current of the induction motor p0320 is increased. This may be the case for rotating measurements (see p1960). The torque limit p1520 can be re-calculated using p0340 = 1, 3 or 5.		
r1547[0...1]	CO: Torque limit for speed controller output / M_max outp n_ctrl		
	Access level: 3	Calculated: -	Data type: FloatingPoint32
	Can be changed: -	Scaling: p2003	Dyn. index: -
	Unit group: 7_1	Unit selection: p0505	Func. diagram: 6060
	Min	Max	Factory setting
	- [Nm]	- [Nm]	- [Nm]
Description:	Displays the torque limit to limit the speed controller output.		

Index: [0] = Upper limit
[1] = Lower limit

r1548[0...1]	CO: Stall current limit torque-generating maximum / Isq_max stall	
Access level: 4	Calculated: -	Data type: FloatingPoint32
Can be changed: -	Scaling: p2002	Dyn. index: -
Unit group: 6_2	Unit selection: p0505	Func. diagram: -
Min	Max	Factory setting
- [Arms]	- [Arms]	- [Arms]
Description:	Displays the limit for the torque-generating current component using the stall calculation, the current limit of the power unit as well as the parameterization in p0640.	
Index:	[0] = Upper limit [1] = Lower limit	

p1552[0...n]	CI: Torque limit upper scaling without offset / M_max up w/o offs	
Access level: 3	Calculated: -	Data type: U32 / FloatingPoint32
Can be changed: T	Scaling: PERCENT	Dyn. index: CDS, p0170
Unit group: -	Unit selection: -	Func. diagram: 6060
Min	Max	Factory setting
-	-	1
Description:	Sets the signal source for the scaling of the upper torque limiting to limit the speed controller output without taking into account the current and power limits.	

p1553[0...n]	Stall limit scaling / Stall limit scal	
Access level: 4	Calculated: -	Data type: FloatingPoint32
Can be changed: U, T	Scaling: -	Dyn. index: DDS, p0180
Unit group: -	Unit selection: -	Func. diagram: -
Min	Max	Factory setting
80.0 [%]	130.0 [%]	100.0 [%]
Description:	Sets the scaling of the stall limit for the start of field weakening.	
Danger:	If the stall current limit is increased, then the q current setpoint can exceed the stall limit; as a consequence, a hysteresis effect can occur when loading and unloading.	
		

p1554[0...n]	CI: Torque limit lower scaling without offset / M_max low w/o offs	
Access level: 3	Calculated: -	Data type: U32 / FloatingPoint32
Can be changed: T	Scaling: PERCENT	Dyn. index: CDS, p0170
Unit group: -	Unit selection: -	Func. diagram: 6060
Min	Max	Factory setting
-	-	1
Description:	Sets the signal source for the scaling of the lower torque limiting to limit the speed controller output without taking into account the current and power limits.	

p1560[0...n]	Moment of inertia estimator accelerating torque threshold value / J_est M thresh	
Access level: 3	Calculated: -	Data type: FloatingPoint32
Can be changed: U, T	Scaling: -	Dyn. index: DDS, p0180
Unit group: -	Unit selection: -	Func. diagram: -
Min	Max	Factory setting
0.10 [%]	100.00 [%]	10.00 [%]
Description:	Sets the threshold for the accelerating torque for the moment of inertia estimator. The moment of inertia estimator is active above this threshold. The value is referred to the rated torque (r0333).	
Dependency:	Refer to: p1400, p1561, p1562	
Note:	The moment of inertia estimation is inaccurate at very low accelerating torques. As a consequence, below this threshold, the estimator does not provide any new values.	

p1561[0...n]	Moment of inertia estimator change time moment of inertia / J_est t J		
	Access level: 3	Calculated: p0340 = 1,3,4	Data type: FloatingPoint32
	Can be changed: U, T	Scaling: -	Dyn. index: DDS, p0180
	Unit group: -	Unit selection: -	Func. diagram: -
	Min	Max	Factory setting
	10.00 [ms]	5000.00 [ms]	500.00 [ms]
Description:	Sets the change time for the moment of inertia for the moment of inertia estimator. Lower values mean that faster changes are possible. For a higher value, this estimated value is smoothed more significantly.		
Dependency:	Refer to: p1400, p1560, p1562		
p1562[0...n]	Moment of inertia estimator change time load / J_est t load		
	Access level: 3	Calculated: p0340 = 1,3,4	Data type: FloatingPoint32
	Can be changed: U, T	Scaling: -	Dyn. index: DDS, p0180
	Unit group: -	Unit selection: -	Func. diagram: -
	Min	Max	Factory setting
	5.00 [ms]	5000.00 [ms]	10.00 [ms]
Description:	Sets the change time for the load torque for the moment of inertia estimator. Lower values mean that faster changes are possible. For a higher value, this estimated value is smoothed more significantly.		
Dependency:	Refer to: p1400, p1560, p1561		
p1563[0...n]	CO: Mom. of inertia estimator load torque direction of rotation pos. / J_est M pos		
	Access level: 3	Calculated: -	Data type: FloatingPoint32
	Can be changed: U, T	Scaling: p2003	Dyn. index: DDS, p0180
	Unit group: -	Unit selection: -	Func. diagram: -
	Min	Max	Factory setting
	-340.28235E36 [Nm]	340.28235E36 [Nm]	0.00 [Nm]
Description:	Display and connector output for the monitored load torque in the positive direction of rotation. The moment of inertia estimator estimates the load torque drawn while the speed is constant.		
Dependency:	Refer to: p1400, p1560, p1561		
p1564[0...n]	CO: Mom. of inertia estimator load torque direction of rotation neg. / J_est M neg		
	Access level: 3	Calculated: -	Data type: FloatingPoint32
	Can be changed: U, T	Scaling: p2003	Dyn. index: DDS, p0180
	Unit group: -	Unit selection: -	Func. diagram: -
	Min	Max	Factory setting
	-340.28235E36 [Nm]	340.28235E36 [Nm]	0.00 [Nm]
Description:	Display and connector output for the monitored load torque in the negative direction of rotation. The moment of inertia estimator estimates the load torque drawn while the speed is constant.		
Dependency:	Refer to: p1400, p1560, p1561		
r1566[0...n]	Flux reduction torque factor transition value / Flux red M trans		
	Access level: 3	Calculated: -	Data type: FloatingPoint32
	Can be changed: -	Scaling: PERCENT	Dyn. index: DDS, p0180
	Unit group: -	Unit selection: -	Func. diagram: 6790
	Min	Max	Factory setting
	- [%]	- [%]	- [%]
Description:	The following applies for a synchronous reluctance motor: Displays the transition value for the start of the evaluation of the optimum flux characteristic. The value is referred to the rated motor torque.		

Note: The transition value corresponds with the lower limit of the flux setpoint (p1581).
For a lower absolute torque setpoint, the flux setpoint remains at the lower limit (p1581).

p1567[0...n]	Magnetization rate time scaling / Mag Tv scale		
	Access level: 4	Calculated: p0340 = 1,3,4	Data type: FloatingPoint32
	Can be changed: U, T	Scaling: -	Dyn. index: DDS, p0180
	Unit group: -	Unit selection: -	Func. diagram: 6790
	Min	Max	Factory setting
	0 [%]	1000 [%]	100 [%]
Description:	The following applies for a synchronous reluctance motor: Sets the scaling of the rate time Tv for dynamic flux increase when the torque is quickly established. The value is referred to the inverse value of the rated motor frequency. Tv = p1567 / 100 % / p0310		
Dependency:	Refer to: p1401		
Note:	The "Dynamic load-dependent flux boost" function can be deactivated using p1401.9 = 0.		

r1568[0...5]	CO: Synchronous reluctance motor flux channel / RESM flux channel		
	Access level: 4	Calculated: -	Data type: FloatingPoint32
	Can be changed: -	Scaling: PERCENT	Dyn. index: -
	Unit group: -	Unit selection: -	Func. diagram: -
	Min	Max	Factory setting
	- [%]	- [%]	- [%]
Description:	Display and connector output for signals of the flux channel for a synchronous reluctance motor (RESM). The values are referred to the rated motor flux of the in-line axis (p0357 * r0331).		
Index:	[0] = Setpoint before filter [1] = Optimum flux characteristic output [2] = Minimum value at low speed [3] = Dynamic load-dependent boost [4] = Field weakening value total [5] = Field weakening value precontrol		
Note:	RESM: reluctance synchronous motor (synchronous reluctance motor)		

p1570[0...n]	CO: Flux setpoint / Flux setp		
	Access level: 3	Calculated: -	Data type: FloatingPoint32
	Can be changed: U, T	Scaling: PERCENT	Dyn. index: DDS, p0180
	Unit group: -	Unit selection: -	Func. diagram: 6722
	Min	Max	Factory setting
	50.0 [%]	200.0 [%]	100.0 [%]
Description:	Sets the flux setpoint referred to rated motor flux.		
Notice:	A BICO interconnection to a parameter that belongs to a drive data set always acts on the effective data set.		
Note:	For p1570 > 100%, the flux setpoint increases as a function of the load from 100% (no-load operation) to the setting in p1570 (above rated motor torque), if p1580 > 0% has been set.		

p1573[0...n]	Flux threshold value magnetizing / Flux thresh magnet		
	Access level: 3	Calculated: -	Data type: FloatingPoint32
	Can be changed: U, T	Scaling: PERCENT	Dyn. index: DDS, p0180
	Unit group: -	Unit selection: -	Func. diagram: 6722
	Min	Max	Factory setting
	10.0 [%]	200.0 [%]	100.0 [%]
Description:	Sets the flux threshold value for enabling the speed setpoint and the end of magnetizing (r0056.4).		
Note:	The parameter only has an influence if the flux actual value reaches the threshold value p1573 more quickly during magnetizing than the time set in p0346. This is generally the case when selecting fast magnetization (p1401.6). The parameter has no influence for flying restart (see p1200) and after DC braking (see p1231).		

p1574[0...n]	Voltage reserve dynamic / U_reserve dyn		
	Access level: 3	Calculated: p0340 = 1,3,5	Data type: FloatingPoint32
	Can be changed: U, T	Scaling: -	Dyn. index: DDS, p0180
	Unit group: 5_1	Unit selection: p0505	Func. diagram: 6723, 6724
	Min	Max	Factory setting
	0.0 [Vrms]	150.0 [Vrms]	10.0 [Vrms]
Description:	Sets a dynamic voltage reserve.		
Dependency:	Refer to: p0500		
Note:	In the field weakening range, it must be expected that the control dynamic performance is somewhat restricted due to the limited possibilities of controlling/adjusting the voltage. This can be improved by increasing the voltage reserve. Increasing the reserve reduces the steady-state maximum output voltage (r0071).		
p1575[0...n]	Voltage target value limit / U_tgt val lim		
	Access level: 4	Calculated: -	Data type: FloatingPoint32
	Can be changed: U, T	Scaling: -	Dyn. index: DDS, p0180
	Unit group: -	Unit selection: -	Func. diagram: 6725
	Min	Max	Factory setting
	50.00 [%]	300.00 [%]	200.00 [%]
Description:	Sets the limit of the voltage target value. In steady-state field weakening operation this corresponds to the required output voltage. The value of 100% refers to p0304.		
Note:	The output voltage is only limited if the maximum output voltage (r0071) minus the voltage reserve (p1574) corresponds to a value higher than p1575. Limiting via p1575 allows the influence of the voltage ripple of the line supply voltage to be eliminated at the operating point.		
p1578[0...n]	Flux reduction flux decrease time constant / Flux red dec T		
	Access level: 3	Calculated: p0340 = 1,3,4	Data type: FloatingPoint32
	Can be changed: U, T	Scaling: -	Dyn. index: DDS, p0180
	Unit group: -	Unit selection: -	Func. diagram: 6791
	Min	Max	Factory setting
	20 [ms]	5000 [ms]	200 [ms]
Description:	The following applies for a synchronous reluctance motor: Sets the time constant for reducing the flux setpoint for a load-dependent optimum flux characteristic.		
Dependency:	Refer to: p1579		
Note:	To avoid remagnetization processes for load-dependent flux characteristics and for fast load changes, the time constant to reduce the flux setpoint must be set to an appropriately high value. As a consequence, it is preset with a multiple of the time constant used for the flux build up.		
p1579[0...n]	Flux reduction flux build-up time constant / Flux red incr T		
	Access level: 3	Calculated: p0340 = 1,3,4	Data type: FloatingPoint32
	Can be changed: U, T	Scaling: -	Dyn. index: DDS, p0180
	Unit group: -	Unit selection: -	Func. diagram: 6791
	Min	Max	Factory setting
	0 [ms]	5000 [ms]	4 [ms]
Description:	The following applies for a synchronous reluctance motor: Sets the time constant for establishing the flux setpoint for a load-dependent optimum flux characteristic.		
Dependency:	Refer to: p1578		
Note:	To quickly establish the flux for torque changes, an appropriately short time constant for the flux build-up must be selected. It is preset with the inverse value of the rated motor frequency (p0310).		

p1580[0...n]	Efficiency optimization / Efficiency opt		
	Access level: 3	Calculated: -	Data type: FloatingPoint32
	Can be changed: U, T	Scaling: -	Dyn. index: DDS, p0180
	Unit group: -	Unit selection: -	Func. diagram: 6722
	Min	Max	Factory setting
	0 [%]	100 [%]	0 [%]
Description:	Sets the efficiency optimization. When optimizing the efficiency, the flux setpoint of the closed-loop control is adapted as a function of the load. For p1580 = 100 %, under no-load operating conditions, the flux setpoint is reduced to 50 % of the rated motor flux.		
Note:	It only makes sense to activate this function if the dynamic response requirements of the speed controller are low. In order to avoid oscillations, if required, the speed controller parameters should be adapted (increase Tn, reduce Kp). Further, the smoothing time of the flux setpoint filter (p1582) should be increased.		
p1581[0...n]	Flux reduction factor / Flux red factor		
	Access level: 3	Calculated: -	Data type: FloatingPoint32
	Can be changed: U, T	Scaling: -	Dyn. index: DDS, p0180
	Unit group: -	Unit selection: -	Func. diagram: -
	Min	Max	Factory setting
	0 [%]	100 [%]	100 [%]
Description:	The following applies for a synchronous reluctance motor: Sets the lower limit of the flux setpoint to evaluate the optimum flux characteristic. The value is referred to the rated motor flux (p0357 * r0331).		
p1582[0...n]	Flux setpoint smoothing time / Flux setp T_smth		
	Access level: 3	Calculated: p0340 = 1,3	Data type: FloatingPoint32
	Can be changed: U, T	Scaling: -	Dyn. index: DDS, p0180
	Unit group: -	Unit selection: -	Func. diagram: 6722, 6724
	Min	Max	Factory setting
	4 [ms]	5000 [ms]	15 [ms]
Description:	Sets the smoothing time for the flux setpoint.		
r1583	Flux setpoint smoothed / Flux setp smooth		
	Access level: 4	Calculated: -	Data type: FloatingPoint32
	Can be changed: -	Scaling: PERCENT	Dyn. index: -
	Unit group: -	Unit selection: -	Func. diagram: 6722, 6723, 6724
	Min	Max	Factory setting
	- [%]	- [%]	- [%]
Description:	Displays the smoothed flux setpoint. The value is referred to the rated motor flux.		
p1584[0...n]	Field weakening operation flux setpoint smoothing time / Field weak T_smth		
	Access level: 4	Calculated: p0340 = 1,3	Data type: FloatingPoint32
	Can be changed: U, T	Scaling: -	Dyn. index: DDS, p0180
	Unit group: -	Unit selection: -	Func. diagram: 6722
	Min	Max	Factory setting
	0 [ms]	20000 [ms]	0 [ms]
Description:	Sets the smoothing time for the flux setpoint in the field-weakening range		
Recommendation:	Smoothing should be especially used if there is no regenerative feedback into the line supply. This means that the DC link voltage can quickly increase in regenerative operation		
Note:	Only the flux setpoint rise is smoothed		

p1586[0...n]	Field weakening characteristic scaling / Field weak scal		
	Access level: 4	Calculated: -	Data type: FloatingPoint32
	Can be changed: U, T	Scaling: -	Dyn. index: DDS, p0180
	Unit group: -	Unit selection: -	Func. diagram: -
	Min	Max	Factory setting
	80.0 [%]	120.0 [%]	100.0 [%]
Description:	Sets the scaling of the precontrol characteristic for the start of field weakening. For values above 100 % and for partial load situations, the field weakening starts at higher speeds.		
Note:	If the start of field weakening is shifted to lower speeds, then the voltage reserve is increased for partial load situations. If the start of field weakening is shifted to higher speeds, the voltage reserve is appropriately reduced so that for fast load changes, it can be expected that this will have a negative impact on the dynamic performance.		
r1589	Field-weakening current precontrol value / I_FieldWeak prectr		
	Access level: 4	Calculated: -	Data type: FloatingPoint32
	Can be changed: -	Scaling: p2002	Dyn. index: -
	Unit group: 6_2	Unit selection: p0505	Func. diagram: 6724
	Min	Max	Factory setting
	- [Arms]	- [Arms]	- [Arms]
Description:	Displays the precontrol value for the field weakening current.		
p1590[0...n]	Flux controller P gain / Flux controller Kp		
	Access level: 4	Calculated: p0340 = 1,3,4	Data type: FloatingPoint32
	Can be changed: U, T	Scaling: -	Dyn. index: DDS, p0180
	Unit group: -	Unit selection: -	Func. diagram: 6723
	Min	Max	Factory setting
	0.0	999999.0	10.0
Description:	Sets the proportional gain for the flux controller.		
Note:	The value is automatically pre-assigned dependent on the motor when the drive system is first commissioned. When calculating controller parameters (p0340 = 4), this value is re-calculated.		
r1593[0...1]	CO: Field weakening controller / flux controller output / Field/Fl_ctrl outp		
	Access level: 4	Calculated: -	Data type: FloatingPoint32
	Can be changed: -	Scaling: p2002	Dyn. index: -
	Unit group: 6_2	Unit selection: p0505	Func. diagram: 6724
	Min	Max	Factory setting
	- [Arms]	- [Arms]	- [Arms]
Description:	Display and connector output for the output of the field weakening controller (synchronous motor).		
Index:	[0] = PI output [1] = I output		
p1594[0...n]	Field-weakening controller P gain / Field_ctrl Kp		
	Access level: 4	Calculated: -	Data type: FloatingPoint32
	Can be changed: U, T	Scaling: -	Dyn. index: DDS, p0180
	Unit group: -	Unit selection: -	Func. diagram: 6724
	Min	Max	Factory setting
	0.00	1000.00	0.00
Description:	Sets the P gain of the field-weakening controller.		

p1595[0...n]	Field weakening controller additional setpoint / Field_ctr add_setp		
	Access level: 4	Calculated: -	Data type: FloatingPoint32
	Can be changed: U, T	Scaling: -	Dyn. index: DDS, p0180
	Unit group: -	Unit selection: -	Func. diagram: 6726
	Min	Max	Factory setting
	-80.00 [%]	50.00 [%]	0.00 [%]
Description:	Sets an additional setpoint for the field weakening controller. The value refers to the dynamic voltage reserve (p1574).		
Note:	For a value equal to zero, the field weakening controller is activated when the maximum voltage, calculated with the average value of the DC link voltage, is reached. Negative values cause the field weakening controller to intervene earlier, so that the voltage can move away from the modulation depth limit.		
p1596[0...n]	Field weakening controller integral-action time / Field_ctrl Tn		
	Access level: 3	Calculated: p0340 = 1,3,4	Data type: FloatingPoint32
	Can be changed: U, T	Scaling: -	Dyn. index: DDS, p0180
	Unit group: -	Unit selection: -	Func. diagram: 6723, 6724
	Min	Max	Factory setting
	10 [ms]	10000 [ms]	300 [ms]
Description:	Sets the integral-action time of the field-weakening controller.		
r1597	CO: Field weakening controller output / Field_ctrl outp		
	Access level: 4	Calculated: -	Data type: FloatingPoint32
	Can be changed: -	Scaling: PERCENT	Dyn. index: -
	Unit group: -	Unit selection: -	Func. diagram: 6723
	Min	Max	Factory setting
	- [%]	- [%]	- [%]
Description:	Displays the output of the field weakening controller. The value is referred to the rated motor flux.		
r1598	CO: Total flux setpoint / Flux setp total		
	Access level: 3	Calculated: -	Data type: FloatingPoint32
	Can be changed: -	Scaling: PERCENT	Dyn. index: -
	Unit group: -	Unit selection: -	Func. diagram: 6714, 6723, 6724, 6725, 6726
	Min	Max	Factory setting
	- [%]	- [%]	- [%]
Description:	Displays the effective flux setpoint. The value is referred to the rated motor flux.		
p1601[0...n]	Current injection ramp time / I_inject t_ramp		
	Access level: 3	Calculated: p0340 = 1,3	Data type: FloatingPoint32
	Can be changed: U, T	Scaling: -	Dyn. index: DDS, p0180
	Unit group: -	Unit selection: -	Func. diagram: 6790
	Min	Max	Factory setting
	1 [ms]	10000 [ms]	20 [ms]
Description:	Synchronous-reluctance motor: Sets the ramp-up time of the current setpoint (p1610, p1611) when switching over from closed-loop controlled to open-loop controlled operation.		

p1610[0...n]	Torque setpoint static (sensorless) / M_set static		
	Access level: 2	Calculated: -	Data type: FloatingPoint32
	Can be changed: U, T	Scaling: -	Dyn. index: DDS, p0180
	Unit group: -	Unit selection: -	Func. diagram: 6700, 6721, 6722, 6726
	Min	Max	Factory setting
	-200.0 [%]	200.0 [%]	50.0 [%]
Description:	Sets the static torque setpoint for sensorless vector control in the low speed range. This parameter is entered as a percentage referred to the rated motor torque (r0333). For sensorless vector control, when the motor model is shut down, an absolute current is impressed. p1610 represents the maximum load that occurs at a constant setpoint speed.		
Notice:	p1610 should always be set to at least 10 % higher than the maximum steady-state load that can occur.		
Note:	For p1610 = 0%, a current setpoint is calculated that corresponds to the no-load case (ASM: rated magnetizing current, RESM: no-load magnetizing current). For p1610 = 100 %, a current setpoint is calculated that corresponds to the rated motor torque. Negative values are converted into positive setpoints in the case of induction and permanent-magnet synchronous motors as well as closed-loop controlled reluctance motors.		
p1611[0...n]	Additional acceleration torque (sensorless) / M_suppl_accel		
	Access level: 2	Calculated: p0340 = 1	Data type: FloatingPoint32
	Can be changed: U, T	Scaling: -	Dyn. index: DDS, p0180
	Unit group: -	Unit selection: -	Func. diagram: 6700, 6721, 6722, 6726
	Min	Max	Factory setting
	0.0 [%]	200.0 [%]	30.0 [%]
Description:	Enters the dynamic torque setpoint for the low-speed range for sensorless vector control. This parameter is entered as a percentage referred to the rated motor torque (r0333).		
Note:	When accelerating and braking p1611 is added to p1610 and the resulting total torque is converted into an appropriate current setpoint and controlled. For pure accelerating torques, it is always favorable to use the torque precontrol of the speed controller (p1496).		
r1614	EMF maximum / EMF max		
	Access level: 4	Calculated: -	Data type: FloatingPoint32
	Can be changed: -	Scaling: p2001	Dyn. index: -
	Unit group: 5_1	Unit selection: p0505	Func. diagram: 6725
	Min	Max	Factory setting
	- [Vrms]	- [Vrms]	- [Vrms]
Description:	Displays the actual maximum possible electromotive force (EMF) of the separately excited synchronous motor.		
Dependency:	The value is the basis for the flux setpoint. The maximum possible EMF depends on the following factors: - Actual DC link voltage (r0070). - Maximum modulation depth (p1803). - Field-generating and torque-generating current setpoint.		
p1616[0...n]	Current setpoint smoothing time / I_set T_smooth		
	Access level: 3	Calculated: p0340 = 1,3	Data type: FloatingPoint32
	Can be changed: U, T	Scaling: -	Dyn. index: DDS, p0180
	Unit group: -	Unit selection: -	Func. diagram: 6721, 6722
	Min	Max	Factory setting
	4 [ms]	10000 [ms]	40 [ms]
Description:	Sets the smoothing time for the current setpoint. The current setpoint is generated from p1610 and p1611.		
Note:	This parameter is only effective in the range where current is injected for sensorless vector control.		

r1623[0...1]	Field-generating current setpoint (steady-state) / Id_set stationary		
	Access level: 4	Calculated: -	Data type: FloatingPoint32
	Can be changed: -	Scaling: p2002	Dyn. index: -
	Unit group: 6_2	Unit selection: p0505	Func. diagram: 6723
	Min	Max	Factory setting
	- [Arms]	- [Arms]	- [Arms]
Description:	Displays the steady-state field generating current setpoint (Id_set).		
Note:	For index [1]: Reserved.		
r1624	Field-generating current setpoint total / Id_setp total		
	Access level: 4	Calculated: -	Data type: FloatingPoint32
	Can be changed: -	Scaling: p2002	Dyn. index: -
	Unit group: 6_2	Unit selection: p0505	Func. diagram: 6640, 6721, 6723, 6727
	Min	Max	Factory setting
	- [Arms]	- [Arms]	- [Arms]
Description:	Displays the limited field-generating current setpoint (Id_set). This value comprises the steady-state field-generating current setpoint r1623 and a dynamic component that is only set when changes are made to the flux setpoint.		
p1654[0...n]	Curr. setpoint torque-gen. smoothing time field weakening range / Isq_s T_smth FW		
	Access level: 4	Calculated: p0340 = 1	Data type: FloatingPoint32
	Can be changed: U, T	Scaling: -	Dyn. index: DDS, p0180
	Unit group: -	Unit selection: -	Func. diagram: 6710
	Min	Max	Factory setting
	0.1 [ms]	50.0 [ms]	4.8 [ms]
Description:	Sets the smoothing time constant for the setpoint of the torque-generating current components.		
Note:	The smoothing time does not become effective until the field-weakening range is reached.		
p1702[0...n]	Isd current controller precontrol scaling / Isd_ctr_prectrScal		
	Access level: 4	Calculated: -	Data type: FloatingPoint32
	Can be changed: U, T	Scaling: -	Dyn. index: DDS, p0180
	Unit group: -	Unit selection: -	Func. diagram: 6714
	Min	Max	Factory setting
	0.0 [%]	200.0 [%]	70.0 [%]
Description:	Sets the scaling of the dynamic current controller precontrol for the flux-generating current component Isd.		
Note:	The parameter is effective for permanent-magnet synchronous motors.		
p1703[0...n]	Isq current controller precontrol scaling / Isq_ctr_prectrScal		
	Access level: 4	Calculated: p0340 = 1,3,4	Data type: FloatingPoint32
	Can be changed: U, T	Scaling: -	Dyn. index: DDS, p0180
	Unit group: -	Unit selection: -	Func. diagram: 6714
	Min	Max	Factory setting
	0.0 [%]	200.0 [%]	60.0 [%]
Description:	Sets the scaling of the dynamic current controller precontrol for the torque/force-generating current component Isq.		

2 Parameters

2.2 List of parameters

p1715[0...n]	Current controller P gain / I_ctrl Kp		
	Access level: 4	Calculated: p0340 = 1,3,4	Data type: FloatingPoint32
	Can be changed: U, T	Scaling: -	Dyn. index: DDS, p0180
	Unit group: -	Unit selection: -	Func. diagram: 6714
	Min	Max	Factory setting
	0.000	100000.000	0.000
Description:	Sets the proportional gain of the current controller. This value is automatically pre-set using p3900 or p0340 when commissioning has been completed.		

p1717[0...n]	Current controller integral-action time / I_ctrl Tn		
	Access level: 4	Calculated: p0340 = 1,3,4	Data type: FloatingPoint32
	Can be changed: U, T	Scaling: -	Dyn. index: DDS, p0180
	Unit group: -	Unit selection: -	Func. diagram: 5714, 6700, 6714, 7017
	Min	Max	Factory setting
	0.00 [ms]	1000.00 [ms]	2.00 [ms]
Description:	Sets the integral-action time of the current controller.		
Dependency:	Refer to: p1715		

r1718	CO: Isq controller output / Isq_ctrl outp		
	Access level: 4	Calculated: -	Data type: FloatingPoint32
	Can be changed: -	Scaling: p2001	Dyn. index: -
	Unit group: 5_1	Unit selection: p0505	Func. diagram: 6714
	Min	Max	Factory setting
	- [Vrms]	- [Vrms]	- [Vrms]
Description:	Displays the actual output of the Isq current controller (torque/force generating current, PI controller). The value contains the proportional and integral components of the PI controller.		

r1719	Isq controller integral component / Isq_ctrl I_comp		
	Access level: 4	Calculated: -	Data type: FloatingPoint32
	Can be changed: -	Scaling: p2001	Dyn. index: -
	Unit group: 5_1	Unit selection: p0505	Func. diagram: 6714
	Min	Max	Factory setting
	- [Vrms]	- [Vrms]	- [Vrms]
Description:	Displays the integral component of the Isq current controller (torque/force-generating current, PI controller).		

p1720[0...n]	Current controller d axis p gain / Id_ctrl Kp		
	Access level: 4	Calculated: p0340 = 1,3,4	Data type: FloatingPoint32
	Can be changed: U, T	Scaling: -	Dyn. index: DDS, p0180
	Unit group: -	Unit selection: -	Func. diagram: -
	Min	Max	Factory setting
	0.000	100000.000	0.000
Description:	Sets the proportional gain of the d-current controller for the lower adaptation current range. This value is automatically pre-set using p3900 or p0340 when commissioning has been completed.		

p1722[0...n]	Current controller d axis integral time / I_ctrl d-axis Tn		
	Access level: 4	Calculated: p0340 = 1,3,4	Data type: FloatingPoint32
	Can be changed: U, T	Scaling: -	Dyn. index: DDS, p0180
	Unit group: -	Unit selection: -	Func. diagram: -
	Min	Max	Factory setting
	0.00 [ms]	1000.00 [ms]	2.00 [ms]
Description:	Sets the integral time of the d-current controller.		

r1723	CO: Isd controller output / Isd_ctrl outp		
	Access level: 4	Calculated: -	Data type: FloatingPoint32
	Can be changed: -	Scaling: p2001	Dyn. index: -
	Unit group: 5_1	Unit selection: p0505	Func. diagram: 6714
	Min	Max	Factory setting
	- [Vrms]	- [Vrms]	- [Vrms]
Description:	Displays the actual output of the Isd current controller (flux-generating current, PI controller). The value contains the proportional and integral components of the PI controller.		
r1724	Isd controller integral component / Isd_ctrl I_comp		
	Access level: 4	Calculated: -	Data type: FloatingPoint32
	Can be changed: -	Scaling: p2001	Dyn. index: -
	Unit group: 5_1	Unit selection: p0505	Func. diagram: 6714
	Min	Max	Factory setting
	- [Vrms]	- [Vrms]	- [Vrms]
Description:	Displays the integral component of the Isd current controller (flux-generating current, PI controller).		
r1725	Isd controller integral component limit / Isd_ctrl I_limit		
	Access level: 4	Calculated: -	Data type: FloatingPoint32
	Can be changed: -	Scaling: p2001	Dyn. index: -
	Unit group: 5_1	Unit selection: p0505	Func. diagram: 6714
	Min	Max	Factory setting
	- [Vrms]	- [Vrms]	- [Vrms]
Description:	Displays the limit value for the integral component of the Isd current controller.		
p1726[0...n]	Quadrature arm decoupling scaling / Trnsv_decpl scal		
	Access level: 4	Calculated: p0340 = 1	Data type: FloatingPoint32
	Can be changed: U, T	Scaling: -	Dyn. index: DDS, p0180
	Unit group: -	Unit selection: -	Func. diagram: 6714
	Min	Max	Factory setting
	0.0 [%]	200.0 [%]	75.0 [%]
Description:	Sets the scaling of the quadrature arm decoupling		
Note:	This parameter is ineffective for sensorless vector control. In this case, p1727 is always used. If p1726 is set to 0, then the quadrature de-coupling is deactivated. The integral component of the Isd current controller remains effective in the complete speed control range. For the closed-loop control of synchronous motors, this parameter is used to scale the current controller de-coupling.		
p1727[0...n]	Quadrature arm decoupling at voltage limit scaling / TrnsvDecplVmaxScal		
	Access level: 4	Calculated: -	Data type: FloatingPoint32
	Can be changed: U, T	Scaling: -	Dyn. index: DDS, p0180
	Unit group: -	Unit selection: -	Func. diagram: 6714
	Min	Max	Factory setting
	0.0 [%]	200.0 [%]	50.0 [%]
Description:	Sets the scaling of quadrature arm decoupling when the voltage limit is reached.		
r1728	De-coupling voltage in-line axis / U_dir-axis_decoupl		
	Access level: 4	Calculated: -	Data type: FloatingPoint32
	Can be changed: -	Scaling: p2001	Dyn. index: -
	Unit group: 5_1	Unit selection: p0505	Func. diagram: -
	Min	Max	Factory setting
	- [Vrms]	- [Vrms]	- [Vrms]
Description:	Displays the actual output of the quadrature channel de-coupling for the d axis.		

r1729	De-coupling voltage quadrature axis / U_quad_decoupl		
	Access level: 4	Calculated: -	Data type: FloatingPoint32
	Can be changed: -	Scaling: p2001	Dyn. index: -
	Unit group: 5_1	Unit selection: p0505	Func. diagram: -
	Min	Max	Factory setting
	- [Vrms]	- [Vrms]	- [Vrms]
Description:	Displays the actual output of the quadrature channel de-coupling for the q axis.		
p1730[0...n]	Isd controller integral component shutdown threshold / Isd ctrl Tn shutd		
	Access level: 4	Calculated: p0340 = 1,3,4	Data type: FloatingPoint32
	Can be changed: U, T	Scaling: -	Dyn. index: DDS, p0180
	Unit group: -	Unit selection: -	Func. diagram: -
	Min	Max	Factory setting
	30 [%]	150 [%]	30 [%]
Description:	Sets the speed threshold for deactivating the integral component of the Isd controller. The d current controller is only effective as P controller for speeds greater than the threshold value. Instead of the integral component, the quadrature arm decoupling is effective.		
Warning:	For settings above 80%, the d current controller is active up to the field weakening limit. When operated at the voltage limit, this can result in an unstable behavior. In order to avoid this, the dynamic voltage reserve p1574 should be increased.		
			
Note:	The parameter value is referred to the synchronous rated motor speed.		
p1731[0...n]	Isd controller combination current time component / Isd ctr I_combi T1		
	Access level: 4	Calculated: p0340 = 1,3,4	Data type: FloatingPoint32
	Can be changed: U, T	Scaling: -	Dyn. index: DDS, p0180
	Unit group: -	Unit selection: -	Func. diagram: -
	Min	Max	Factory setting
	0.00 [ms]	10000.00 [ms]	0.00 [ms]
Description:	Sets the time constant to calculate the d current DC component difference (combination current) to add to the d current controller actual value.		
Note:	It is not added for p1731 = 0.		
r1732[0...1]	CO: Direct-axis voltage setpoint / Direct U set		
	Access level: 3	Calculated: -	Data type: FloatingPoint32
	Can be changed: -	Scaling: p2001	Dyn. index: -
	Unit group: 5_1	Unit selection: p0505	Func. diagram: 5700, 5714, 6714, 5718
	Min	Max	Factory setting
	- [Vrms]	- [Vrms]	- [Vrms]
Description:	Display and connector output for the direct axis voltage setpoint Ud.		
Index:	[0] = Unsmoothed [1] = Smoothed with p0045		
r1733[0...1]	CO: Quadrature-axis voltage setpoint / Quad U set		
	Access level: 3	Calculated: -	Data type: FloatingPoint32
	Can be changed: -	Scaling: p2001	Dyn. index: -
	Unit group: 5_1	Unit selection: p0505	Func. diagram: 6714, 6731
	Min	Max	Factory setting
	- [Vrms]	- [Vrms]	- [Vrms]
Description:	Display and connector output for the quadrature axis voltage setpoint Uq.		
Index:	[0] = Unsmoothed [1] = Smoothed with p0045		

p1740[0...n]	Gain resonance damping for encoderless closed-loop control / Gain res_damp		
	Access level: 3	Calculated: p0340 = 1,3,4	Data type: FloatingPoint32
	Can be changed: U, T	Scaling: -	Dyn. index: DDS, p0180
	Unit group: -	Unit selection: -	Func. diagram: -
	Min	Max	Factory setting
	0.000	10.000	0.025
Description:	Defines the gain of the controller for resonance damping for operation with sensorless vector control in the range that current is injected.		
p1745[0...n]	Motor model error threshold stall detection / MotMod ThreshStall		
	Access level: 3	Calculated: p0340 = 1,3	Data type: FloatingPoint32
	Can be changed: U, T	Scaling: -	Dyn. index: DDS, p0180
	Unit group: -	Unit selection: -	Func. diagram: -
	Min	Max	Factory setting
	0.0 [%]	1000.0 [%]	5.0 [%]
Description:	Sets the fault threshold in order to detect a motor that has stalled. If the error signal (r1746) exceeds the parameterized error threshold, then status signal r1408.12 is set to 1.		
Dependency:	If a stalled drive is detected (r1408.12 = 1), fault F07902 is output after the delay time set in p2178.		
Note:	Refer to: p2178 Monitoring is only effective in the low-speed range (below p1755 * (100% - p1756)).		
r1746	Motor model error signal stall detection / MotMod sig stall		
	Access level: 3	Calculated: -	Data type: FloatingPoint32
	Can be changed: -	Scaling: -	Dyn. index: -
	Unit group: -	Unit selection: -	Func. diagram: -
	Min	Max	Factory setting
	- [%]	- [%]	- [%]
Description:	Signal to initiate stall detection		
Note:	The signal is not calculated while magnetizing and only in the low speed range (below p1755 * (100% - p1756)).		
p1749[0...n]	Motor model increase changeover speed encoderless operation / Incr n_chng no enc		
	Access level: 4	Calculated: p0340 = 1,3	Data type: FloatingPoint32
	Can be changed: U, T	Scaling: -	Dyn. index: DDS, p0180
	Unit group: -	Unit selection: -	Func. diagram: -
	Min	Max	Factory setting
	0.0 [%]	99.0 [%]	50.0 [%]
Description:	Minimum operating frequency for rugged operation. If the minimum value is greater than the lower changeover limit parameterized with p1755 * (1 - 2 * p1756), then the difference is displayed using p1749 * p1755. The parameter value cannot be changed.		
Dependency:	Refer to: p1755, p1756		

p1750[0...n]	Motor model configuration / MotMod config				
	Access level: 3	Calculated: p0340 = 1,3,5	Data type: Unsigned16		
	Can be changed: U, T	Scaling: -	Dyn. index: DDS, p0180		
	Unit group: -	Unit selection: -	Func. diagram: -		
	Min	Max	Factory setting		
	-	-	0000 0000 0000 0000 bin		
Description:	<p>Sets the configuration for the motor model.</p> <p>Bit 0 = 1: Forces open-loop speed-controlled starting (ASM).</p> <p>Bit 1 = 1: Forces the system to pass through frequency zero, open-loop-controlled (ASM).</p> <p>Bit 2 = 1: Drive remains in full closed-loop control mode, even at zero frequency (ASM).</p> <p>Bit 3 = 1: Motor model evaluates the saturation characteristic (ASM).</p> <p>Bit 6 = 1: If the motor is blocked, sensorless vector control remains speed-controlled (ASM).</p> <p>Bit 7 = 1: Use rugged switchover limits to switchover the model (open-loop/closed-loop controlled) for regenerative operation (ASM).</p> <p>Bit 8 = 1: Open-loop speed controlled operation independent of the speed setpoint (except for OFF3) (ASM).</p>				
Bit field:	Bit	Signal name	1 signal	0 signal	FP
	00	Controlled start	Yes	No	-
	01	Controlled through 0 Hz	Yes	No	-
	02	Closed-loop ctrl oper. down to zero freq. for passive loads	Yes	No	-
	03	Motor model Lh_pre = f(PsiEst)	Yes	No	-
	06	Closed-/open-loop controlled when motor is blocked	Yes	No	-
	07	Use rugged changeover limits	Yes	No	-
	08	Closed-loop controlled until wait time p1758 has expired	Yes	No	-
Dependency:	Refer to: p0500				
Caution:	Do not use bit 6 = 1 if the motor can be slowly reversed by the load at the torque limit. Long delay times due to blocking (p2177 > p1758) can cause the motor to stall. In this case you should deactivate the function or use closed-loop control throughout the speed range (note the information re bit 2 = 1).				
					

Note: Bits 0 ... 2 only have an influence for sensorless vector control, bit 2 is pre-assigned depending on p0500.

For bit 2 = 1:
The sensorless vector control is effective down to zero frequency. A change is not made into the open-loop speed controlled mode.
This operating mode is possible for passive loads. These include applications where the load itself does not generate any active torque and therefore only acts reactively to the drive torque of the induction motor.
If bit 2 = 1, then bit 3 is automatically set to 1. Manual de-selection is possible and may be sensible if the saturation characteristic (p1960) was not measured for third-party motors. Generally, for standard SIEMENS motors, the already pre-assigned (default value) saturation characteristic is adequate.
When the bit is set, the selection of bits 0 and 1 is ignored.

For bit 2 = 0:
Bit 3 is also automatically deactivated.

For bit 6 = 1:
The following applies for sensorless vector control of induction motors:
For a blocked motor (see p2175, p2177) the time condition in p1758 is bypassed and a change is not made into open-loop controlled operation.

For bit 7 = 1:
The following applies for sensorless vector control of induction motors:
If the changeover limits are parameterized too low (p1755, p1756), then they are automatically increased to rugged values by the absolute amount $p1749 * p1755$.
The effective time condition for changing over into open-controlled operation is obtained from the minimum value of p1758 and $0.5 * r0384$.
Is recommended that bit 7 is activated for applications that demand a high torque at low frequencies, and at the same time require low speed gradients..
Adequate parameterization of the current setpoint must be ensured (p1610, p1611).

For bit 8 = 1: no influence on the functionality of bits 0, 1, 2
The following applies for sensorless vector control of induction motors:
Changeover into open-loop speed controlled operation is no longer dependent on the speed setpoint (except for OFF3), but instead is essentially dependent on time condition p1758. As a consequence, a drive can be started or reversed in closed-loop speed controlled operation with setpoints from an external control system, if these briefly lie in the open-loop speed control range.

r1751**Motor model status / MotMod status**

Access level: 3	Calculated: -	Data type: Unsigned32
Can be changed: -	Scaling: -	Dyn. index: -
Unit group: -	Unit selection: -	Func. diagram: -
Min	Max	Factory setting
-	-	-

Description:

Displays the status of the motor model.

Bit field:

Bit	Signal name	1 signal	0 signal	FP
00	Controlled operation	Active	Inactive	6721
01	Set ramp-function generator	Active	Inactive	-
02	Stop Rslh adaptation	Yes	No	-
03	Feedback	Active	Inactive	-
05	Holding angle	Yes	No	-
06	Acceleration criterion	Active	Inactive	-
11	Speed controller output cannot be set to zero	Yes	No	-
12	Rs adapt waits	Yes	No	-
13	Motor operation	Yes	No	-
14	Stator frequency sign	Positive	Negative	-
15	Torque sign	Motor mode	Regenerative mode	-
17	Operation with rugged model feedback	Enabled	Inhibited	-
18	Operation of the current model with current feedback	Enabled	Inhibited	-
19	Current feedback in the current model	Active	Inactive	-
20	Rugged increase of the changeover limits	Active	Inactive	-

2 Parameters

2.2 List of parameters

Note: For bit 17:
Displays the enabled status of the rugged model feedback (p1784).
The feedback is used to increase the parameter ruggedness of the motor model and is effective in the operating range of the two-component closed loop current control.

For bit 18:
Displays the status when enabling the differential current feedback in the current model for operation with encoder.
The function is automatically enabled with $p1784 > 0$ or $p1731 > 0$. The feedback is used for a rugged change between the current model and complete machine model with active rugged model feedback and combination current.

For bit 19:
Displays the currently active stator circuit feedback in current model operation.

For bit 20:
Displays the currently effective increase of the changeover limits by the value $p1749 * p1755$.

p1755[0...n] Motor model changeover speed encoderless operation / MotMod n_chgSnsorI

Access level: 3	Calculated: p0340 = 1,3	Data type: FloatingPoint32
Can be changed: U, T	Scaling: -	Dyn. index: DDS, p0180
Unit group: 3_1	Unit selection: p0505	Func. diagram: -
Min	Max	Factory setting
0.00 [rpm]	210000.00 [rpm]	210000.00 [rpm]

Description: Sets the speed to change over the motor model to encoderless operation.

Dependency: Refer to: p1749, p1756

Notice: The changeover speed represents the steady-state minimum speed up to which the motor model can be used in sensorless steady-state operation.
If the stability is not adequate close to the changeover speed, it may make sense to increase the parameter value. On the other hand, very low changeover speeds can negatively impact the stability.

Note: The changeover speed applies for the changeover between open-loop and closed-loop control mode.

p1756 Motor model changeover speed hysteresis encoderless operation / MotMod n_chgov hys

Access level: 3	Calculated: p0340 = 1,3	Data type: FloatingPoint32
Can be changed: U, T	Scaling: -	Dyn. index: -
Unit group: -	Unit selection: -	Func. diagram: 6730, 6731
Min	Max	Factory setting
0.0 [%]	95.0 [%]	50.0 [%]

Description: Sets the hysteresis for the changeover speed of the motor model for encoderless operation.

Dependency: Refer to: p1755

Note: The parameter value refers to p1755.

Extremely small hystereses can have a negative impact on the stability in the changeover speed range, and very high hystereses in the standstill range.

p1758[0...n] Motor model changeover delay time closed/open-loop control / MotMod t_cl_op

Access level: 3	Calculated: -	Data type: FloatingPoint32
Can be changed: U, T	Scaling: -	Dyn. index: DDS, p0180
Unit group: -	Unit selection: -	Func. diagram: -
Min	Max	Factory setting
100 [ms]	10000 [ms]	500 [ms]

Description: Sets the minimum time for falling below the changeover speed when changing from closed-loop controlled operation to open-loop controlled operation.

Dependency: The wait time has no significance if the setpoint speed before the ramp-function generator lies in the open-loop speed controlled operating range. In this case, the change is made without any delay.

Refer to: p1755, p1756

Note: If p1758 is changed, commissioning must be selected in order to validate the value for the blocking monitoring.

p1759[0...n]	Motor model changeover delay time open/closed-loop control / MotMod t op_cl		
	Access level: 3	Calculated: p0340 = 1,3,5	Data type: FloatingPoint32
	Can be changed: U, T	Scaling: -	Dyn. index: DDS, p0180
	Unit group: -	Unit selection: -	Func. diagram: -
	Min	Max	Factory setting
	0 [ms]	2000 [ms]	0 [ms]
Description:	Sets the minimum time for a transition from open-loop controlled to closed-loop controlled operation after the lower changeover speed $p1755 * (1 - p1756 / 100 \%)$ has been exceeded.		
Dependency:	Refer to: p1755, p1756		
Note:	With p1759 = 2000 ms, the delay time becomes ineffective and the model changeover is determined by the output frequency only (changeover for p1755).		
r1762[0...1]	Motor model deviation component 1 / MotMod dev comp 1		
	Access level: 4	Calculated: -	Data type: FloatingPoint32
	Can be changed: -	Scaling: -	Dyn. index: -
	Unit group: -	Unit selection: -	Func. diagram: 6730
	Min	Max	Factory setting
	-	-	-
Description:	Displays the referred imaginary system deviation for the adaptation circuit of the motor model.		
Index:	[0] = Deviation model 1 [1] = Deviation model 2		
r1763	Motor model deviation component 2 / MotMod dev comp 2		
	Access level: 4	Calculated: -	Data type: FloatingPoint32
	Can be changed: -	Scaling: -	Dyn. index: -
	Unit group: -	Unit selection: -	Func. diagram: -
	Min	Max	Factory setting
	-	-	-
Description:	Displays the referred real system deviation for the adaptation circuit of the motor model.		
p1764[0...n]	Motor model without encoder speed adaptation Kp / MotMod woE n_adaKp		
	Access level: 4	Calculated: p0340 = 1,3,4	Data type: FloatingPoint32
	Can be changed: U, T	Scaling: -	Dyn. index: DDS, p0180
	Unit group: -	Unit selection: -	Func. diagram: 6730
	Min	Max	Factory setting
	0.000	100000.000	1000.000
Description:	Sets the proportional gain of the controller for speed adaptation without encoder.		
r1765	Motor model speed adaptation Kp effective / MotM n_ada Kp act		
	Access level: 4	Calculated: -	Data type: FloatingPoint32
	Can be changed: -	Scaling: p2001	Dyn. index: -
	Unit group: -	Unit selection: -	Func. diagram: -
	Min	Max	Factory setting
	-	-	-
Description:	Displays the effective proportional gain of the controller for the speed adaptation.		

p1767[0...n]	Motor model without encoder speed adaptation Tn / MotMod woE n_adaTn		
	Access level: 4	Calculated: p0340 = 1,3,4	Data type: FloatingPoint32
	Can be changed: U, T	Scaling: -	Dyn. index: DDS, p0180
	Unit group: -	Unit selection: -	Func. diagram: 6730
	Min	Max	Factory setting
	1 [ms]	200 [ms]	4 [ms]
Description:	Sets the integral time of the controller for speed adaptation without encoder		
r1768	Motor model speed adaptation Vi effective / MotM n_ada Vi act		
	Access level: 4	Calculated: -	Data type: FloatingPoint32
	Can be changed: -	Scaling: p2001	Dyn. index: -
	Unit group: -	Unit selection: -	Func. diagram: -
	Min	Max	Factory setting
	-	-	-
Description:	Displays the effective gain of the integral component of the controller for speed adaptation.		
p1769[0...n]	Motor model changeover delay time closed-loop control / MotMod t_cl_ctrl		
	Access level: 4	Calculated: -	Data type: FloatingPoint32
	Can be changed: U, T	Scaling: -	Dyn. index: DDS, p0180
	Unit group: -	Unit selection: -	Func. diagram: -
	Min	Max	Factory setting
	0 [ms]	10000 [ms]	0 [ms]
Description:	Sets the wait time for a transition from open-loop controlled to closed-loop controlled operation after twice the lower changeover speed p1755 * (1 - p1756 / 100 %) has been exceeded - and below the upper switchover speed p1755.		
Dependency:	Refer to: p1755, p1756		
Note:	With p1759 = 0 ms and above p1755, the delay time becomes ineffective and the model changeover is determined by the output frequency only (changeover for p1755).		
r1770	CO: Motor model speed adaptation proportional component / MotMod n_adapt Kp		
	Access level: 4	Calculated: -	Data type: FloatingPoint32
	Can be changed: -	Scaling: p2000	Dyn. index: -
	Unit group: 3_1	Unit selection: p0505	Func. diagram: 6730
	Min	Max	Factory setting
	- [rpm]	- [rpm]	- [rpm]
Description:	Displays the P component of the controller for speed adaptation.		
r1771	CO: Motor model speed adaptation I comp. / MotMod n_adapt Tn		
	Access level: 4	Calculated: -	Data type: FloatingPoint32
	Can be changed: -	Scaling: p2000	Dyn. index: -
	Unit group: 3_1	Unit selection: p0505	Func. diagram: 6730
	Min	Max	Factory setting
	- [rpm]	- [rpm]	- [rpm]
Description:	Displays the I component of the controller for speed adaptation.		

r1773[0...1]	Motor model slip speed / MotMod slip		
	Access level: 4	Calculated: -	Data type: FloatingPoint32
	Can be changed: -	Scaling: -	Dyn. index: -
	Unit group: 3_1	Unit selection: p0505	Func. diagram: -
	Min	Max	Factory setting
	- [rpm]	- [rpm]	- [rpm]
Description:	Displays estimated (speed) signals of the motor model. r1773[0]: Displays the estimated (mechanical) slip of the motor model. r1773[1]: Displays the estimated input speed of the motor model.		
Index:	[0] = Slip speed estimated [1] = Speed estimated		
p1774[0...n]	Motor model offset voltage compensation alpha / MotMod offs comp A		
	Access level: 4	Calculated: -	Data type: FloatingPoint32
	Can be changed: U, T	Scaling: -	Dyn. index: DDS, p0180
	Unit group: -	Unit selection: -	Func. diagram: -
	Min	Max	Factory setting
	-5.000 [V]	5.000 [V]	0.000 [V]
Description:	Sets the offset voltage in the alpha direction; this compensates the offset voltages of the drive converter/inverter at low speeds. The value is valid for the rated (nominal) pulse frequency of the power unit.		
Note:	The value is pre-set during the rotating measurement.		
p1775[0...n]	Motor model offset voltage compensation beta / MotMod offs comp B		
	Access level: 4	Calculated: -	Data type: FloatingPoint32
	Can be changed: U, T	Scaling: -	Dyn. index: DDS, p0180
	Unit group: -	Unit selection: -	Func. diagram: -
	Min	Max	Factory setting
	-5.000 [V]	5.000 [V]	0.000 [V]
Description:	Sets the offset voltage in the beta direction; this compensates the offset voltages of the drive converter/inverter at low speeds. The value is valid for the rated (nominal) pulse frequency of the power unit.		
Note:	The value is pre-set during the rotating measurement.		
r1776[0...6]	Motor model status signals / MotMod status sig		
	Access level: 4	Calculated: -	Data type: FloatingPoint32
	Can be changed: -	Scaling: -	Dyn. index: -
	Unit group: -	Unit selection: -	Func. diagram: -
	Min	Max	Factory setting
	-	-	-
Description:	Displays the internal status signals of the motor model. Index 0: Changeover ramp between current and voltage models Index 1: changeover ramp for the model feedback Index 2: changeover ramp for the zero frequency range		
Index:	[0] = Changeover ramp motor model [1] = Changeover ramp model tracking [2] = Changeover ramp zero frequency induction motor without encoder [3...6] = Reserved		
Note:	ASM: induction motor		

r1778	Motor model flux angle difference / MotMod ang diff		
	Access level: 4	Calculated: -	Data type: FloatingPoint32
	Can be changed: -	Scaling: p2005	Dyn. index: -
	Unit group: -	Unit selection: -	Func. diagram: -
	Min	Max	Factory setting
	- [°]	- [°]	- [°]
Description:	Displays the difference between the motor model flux angle and the transformation angle.		

p1780[0...n]	Motor model adaptation configuration / MotMod adapt conf		
	Access level: 3	Calculated: p0340 = 1,3,4	Data type: Unsigned16
	Can be changed: U, T	Scaling: -	Dyn. index: DDS, p0180
	Unit group: -	Unit selection: -	Func. diagram: -
	Min	Max	Factory setting
	-	-	0000 0000 0101 1100 bin

Description: Sets the configuration for the adaptation circuit of the motor model. Induction motor (ASM): Rs, Lh, and offset compensation.

Bit field:	Bit	Signal name	1 signal	0 signal	FP
	01	Select motor model ASM Rs adaptation	Yes	No	-
	02	Select motor model ASM Lh adaptation	Yes	No	-
	04	Select motor model offset adaptation	Yes	No	-
	06	Select pole position identification PMSM encoderless	Yes	No	-
	07	Select T(valve) with Rs adaptation	Yes	No	-
	08	Deselect prelim. meas. of inductance for pole position ident.	Yes	No	-
	10	Filter time combination current like current ctrl integral time	Yes	No	-
	14	Delay of the precontrol speed to the motor model	Yes	No	-
	15	RESM Q flux model linear active	Yes	No	-

Dependency: In U/f characteristic operating mode only bit 7 is relevant.

For active motor model feedback (see p1784), the Lh adaptation is internally deactivated automatically.

Note: ASM: Induction motor

When selecting the compensation of the valve interlocking via Rs (bit 7), the compensation in the gating unit is deactivated and is instead taken into account in the motor model.

In order that the correction values of the Rs, Lh and kT adaptation (selected using Bit 0 ... Bit 2) are correctly accepted when changing over the drive data set, a dedicated motor number must be entered into p0826 for each different motor.

p1784[0...n]	Motor model feedback scaling / MotMod fdbk scal		
	Access level: 4	Calculated: p0340 = 1,3,4	Data type: FloatingPoint32
	Can be changed: U, T	Scaling: -	Dyn. index: DDS, p0180
	Unit group: -	Unit selection: -	Func. diagram: -
	Min	Max	Factory setting
	0.0 [%]	1000.0 [%]	0.0 [%]

Description: Sets the scaling for model fault feedback.

Note: Feeding back the measured model fault to the model states increases the control stability and makes the motor model rugged against parameter errors.

When feedback is selected (p1784 > 0), Lh adaptation is not effective.

p1785[0...n]	Motor model Lh adaptation Kp / MotMod Lh Kp		
	Access level: 4	Calculated: p0340 = 1,3,4	Data type: FloatingPoint32
	Can be changed: U, T	Scaling: -	Dyn. index: DDS, p0180
	Unit group: -	Unit selection: -	Func. diagram: -
	Min	Max	Factory setting
	0.000	10.000	0.100
Description:	Sets the proportional gain for the Lh adaptation of the motor model for an induction motor (ASM).		
p1786[0...n]	Motor model Lh adaptation integral time / MotMod Lh Tn		
	Access level: 4	Calculated: p0340 = 1,3,4	Data type: FloatingPoint32
	Can be changed: U, T	Scaling: -	Dyn. index: DDS, p0180
	Unit group: -	Unit selection: -	Func. diagram: -
	Min	Max	Factory setting
	10 [ms]	10000 [ms]	100 [ms]
Description:	Sets the integral time for the Lh adaptation of the motor model for an induction motor (ASM).		
r1787[0...n]	Motor model Lh adaptation corrective value / MotMod Lh corr		
	Access level: 4	Calculated: -	Data type: FloatingPoint32
	Can be changed: -	Scaling: -	Dyn. index: DDS, p0180
	Unit group: -	Unit selection: -	Func. diagram: -
	Min	Max	Factory setting
	- [mH]	- [mH]	- [mH]
Description:	Displays the corrective value for the Lh adaptation of the motor model for an induction motor (ASM).		
Dependency:	Refer to: p0826, p1780		
Note:	The adaptation result is reset if the magnetizing inductance of the induction motor is changed (p0360, r0382). This also happens when changing over the data set if a different motor is not being used (p0826). The display of the inactive data sets is only updated when changing over the data set.		
r1791	Motor model Lh adaptation switch-on frequency / MotMod Lh f_on		
	Access level: 4	Calculated: -	Data type: FloatingPoint32
	Can be changed: -	Scaling: -	Dyn. index: -
	Unit group: -	Unit selection: -	Func. diagram: -
	Min	Max	Factory setting
	- [Hz]	- [Hz]	- [Hz]
Description:	Displays the switch-on stator frequency/ primary section frequency for the Lh adaptation for the induction motor (ASM).		
r1792	Motor model Lh adaptation switch-on slip / MotMod Lh fslip		
	Access level: 4	Calculated: -	Data type: FloatingPoint32
	Can be changed: -	Scaling: -	Dyn. index: -
	Unit group: -	Unit selection: -	Func. diagram: -
	Min	Max	Factory setting
	- [Hz]	- [Hz]	- [Hz]
Description:	Displays the switch-on slip frequency for the Lh adaptation for the induction motor (ASM).		
p1795[0...n]	Motor model kT adaptation integral time / MotMod kT Tn		
	Access level: 3	Calculated: p0340 = 1,3,4	Data type: FloatingPoint32
	Can be changed: U, T	Scaling: -	Dyn. index: DDS, p0180
	Unit group: -	Unit selection: -	Func. diagram: 6731
	Min	Max	Factory setting
	10 [ms]	10000 [ms]	100 [ms]
Description:	Sets the integral time of the kT adaptation of the motor model for a permanent-magnet synchronous motor (PMSM).		

r1797[0...n]	Motor model kT adaptation corrective value / MotMod kT corr		
	Access level: 3	Calculated: -	Data type: FloatingPoint32
	Can be changed: -	Scaling: -	Dyn. index: DDS, p0180
	Unit group: -	Unit selection: -	Func. diagram: 6731
	Min	Max	Factory setting
	- [Nm/A]	- [Nm/A]	- [Nm/A]
Description:	Displays the corrective value of the kT adaptation of the motor model for a permanent-magnet synchronous motor (PMSM).		
Dependency:	Refer to: p0826, p1780		
Note:	The display of the inactive data sets is only updated when changing over the data set.		
p1800[0...n]	Pulse frequency setpoint / Pulse freq setp		
	Access level: 2	Calculated: -	Data type: FloatingPoint32
	Can be changed: U, T	Scaling: -	Dyn. index: DDS, p0180
	Unit group: -	Unit selection: -	Func. diagram: 8021
	Min	Max	Factory setting
	2.000 [kHz]	16.000 [kHz]	4.000 [kHz]
Description:	Sets the pulse frequency for the converter. This parameter is pre-set to the rated converter value when the drive is first commissioned.		
Dependency:	Minimum pulse frequency: $p1800 \geq 12 * p1082 * r0313 / 60$		
Note:	The maximum and minimum possible pulse frequency is also determined by the power unit being used (minimum pulse frequency: 2 kHz or 4 kHz). When the pulse frequency is increased, depending on the particular power unit, the maximum output current can be reduced (derating, refer to r0067). If a sine-wave filter is parameterized as output filter ($p0230 = 3$), then the pulse frequency cannot be set below the minimum value required for the filter. For operation with output reactors, the pulse frequency is limited to 4 kHz (see p0230). If p1800 is changed during commissioning ($p0010 > 0$), then it is possible that the old value will no longer be able to be set. The reason for this is that the dynamic limits of p1800 have been changed by a parameter that was set when the drive was commissioned (e.g. p1082). The pulse frequency cannot be changed when the motor data identification is activated.		
r1801[0...1]	CO: Pulse frequency / Pulse frequency		
	Access level: 2	Calculated: -	Data type: FloatingPoint32
	Can be changed: -	Scaling: p2000	Dyn. index: -
	Unit group: -	Unit selection: -	Func. diagram: -
	Min	Max	Factory setting
	- [kHz]	- [kHz]	- [kHz]
Description:	Display and connector output for the actual converter switching frequency.		
Index:	[0] = Actual [1] = Modulator minimum value		
Note:	The selected pulse frequency (p1800) may be reduced if the drive converter has an overload condition (p0290).		
p1802[0...n]	Modulator mode / Modulator mode		
	Access level: 3	Calculated: p0340 = 1,3,5	Data type: Integer16
	Can be changed: T	Scaling: -	Dyn. index: DDS, p0180
	Unit group: -	Unit selection: -	Func. diagram: -
	Min	Max	Factory setting
	0	10	0
Description:	Sets the modulator mode.		

Value:	0: Automatic changeover SVM/FLB 2: Space vector modulation (SVM) 3: SVM without overcontrol 4: SVM/FLB without overcontrol 10: SVM/FLB with modulation depth reduction
Dependency:	If a sine-wave filter is parameterized as output filter (p0230 = 3, 4), then only space vector modulation without overcontrol can be selected as modulation type (p1802 = 3). Refer to: p0500
Note:	When modulation modes are enabled that could lead to overmodulation (p1802 = 0, 2, 10), the modulation depth must be limited using p1803 (default, p1803 < 100 %). The higher the overmodulation, the greater the current ripple and torque ripple. When changing p1802[x], the values for all of the other existing indices are also changed.

p1803[0...n]	Maximum modulation depth / Modulat depth max	
Access level: 3	Calculated: p0340 = 1,3,5	Data type: FloatingPoint32
Can be changed: U, T	Scaling: -	Dyn. index: DDS, p0180
Unit group: -	Unit selection: -	Func. diagram: 6723
Min	Max	Factory setting
20.0 [%]	150.0 [%]	106.0 [%]
Description:	Defines the maximum modulation depth.	
Dependency:	Refer to: p0500	
Note:	p1803 = 100% is the overcontrol limit for space vector modulation (for an ideal drive converter without any switching delay).	

p1806[0...n]	Filter time constant Vdc correction / T_filt Vdc_corr	
Access level: 4	Calculated: p0340 = 1,3	Data type: FloatingPoint32
Can be changed: U, T	Scaling: -	Dyn. index: DDS, p0180
Unit group: -	Unit selection: -	Func. diagram: -
Min	Max	Factory setting
0.0 [ms]	10000.0 [ms]	0.0 [ms]
Description:	Sets the filter time constant for the DC link voltage. This time constant is used to calculate the modulation depth.	

r1808	DC link voltage actual value for U_max calculation / Vdc act val U_max	
Access level: 4	Calculated: -	Data type: FloatingPoint32
Can be changed: -	Scaling: p2001	Dyn. index: -
Unit group: 5_2	Unit selection: p0505	Func. diagram: -
Min	Max	Factory setting
- [V]	- [V]	- [V]
Description:	DC link voltage used to determine the maximum possible output voltage.	

r1809	CO: Modulator mode actual / Modulator mode act	
Access level: 4	Calculated: -	Data type: Integer16
Can be changed: -	Scaling: -	Dyn. index: -
Unit group: -	Unit selection: -	Func. diagram: -
Min	Max	Factory setting
1	9	-
Description:	Displays the effective modulator mode.	
Value:	1: Flat top modulation (FLB) 2: Space vector modulation (SVM) 9: Optimized pulse pattern	

p1810	Modulator configuration / Modulator config			
	Access level: 4	Calculated: -	Data type: Unsigned16	
	Can be changed: U, T	Scaling: -	Dyn. index: -	
	Unit group: -	Unit selection: -	Func. diagram: -	
	Min	Max	Factory setting	
	-	-	0000 bin	
Description:	Sets the configuration for the modulator.			
Bit field:	Bit	Signal name	1 signal	0 signal
	00	Avg value filter for U_lim (only for Vdc_comp in modulator)	Yes	No
	01	DC link voltage compensation in the current control	Yes	No
Notice:	Bit 1 = 1 can only be set under a pulse inhibit and for r0192.14 = 1.			
Note:	For bit 00 = 0: Voltage limitation from the minimum of the DC link voltage (lower ripple in the output current, reduced output voltage). For bit 00 = 1: Voltage limitation from averaged DC link voltage (higher output voltage with increased ripple in the output current). p1803 should be changed to adapt the output voltage limit. The selection is only valid if the DC link compensation is not performed in the Control Unit (bit 1 = 0). For bit 01 = 0: DC link voltage compensation in the modulator. For bit 01 = 1: DC link voltage compensation in the current control (higher output current ripple).			
p1820[0...n]	Reverse the output phase sequence / Outp_ph_seq rev			
	Access level: 2	Calculated: -	Data type: Integer16	
	Can be changed: T	Scaling: -	Dyn. index: DDS, p0180	
	Unit group: -	Unit selection: -	Func. diagram: -	
	Min	Max	Factory setting	
	0	1	0	
Description:	Sets the phase sequence reversal for the motor without setpoint change. If the motor does not rotate in the required direction, then the output phase sequence can be reversed using this parameter. This means that the direction of the motor is reversed without the setpoint being changed.			
Value:	0: OFF 1: ON			
Note:	This setting can only be changed when the pulses are inhibited.			
p1822	Power unit line phases monitoring tolerance time / PU ph monit t_tol			
	Access level: 4	Calculated: -	Data type: Unsigned32	
	Can be changed: T	Scaling: -	Dyn. index: -	
	Unit group: -	Unit selection: -	Func. diagram: -	
	Min	Max	Factory setting	
	500 [ms]	540000 [ms]	1000 [ms]	
Description:	Sets the tolerance time for line phase monitoring for blocksize power units. If a line phase fault is present for longer than this tolerance time, then a corresponding fault is output.			
Dependency:	Refer to: F30011			
Notice:	When operating with a failed line phase, depending on the active power, values higher than the default value can either immediately damage the power unit or damage it over the long term.			
Note:	For the setting p1822 = maximum value, line phase monitoring is deactivated.			

p1825	Converter valve threshold voltage / Threshold voltage		
	Access level: 4	Calculated: p0340 = 1	Data type: FloatingPoint32
	Can be changed: U, T	Scaling: -	Dyn. index: -
	Unit group: -	Unit selection: -	Func. diagram: -
	Min	Max	Factory setting
	0.0 [Vrms]	100.0 [Vrms]	0.6 [Vrms]
Description:	Sets the threshold voltage drop of the valves (power semiconductor devices) to be compensated.		
Note:	The value is automatically calculated in the motor data identification routine.		
p1828	Compensation valve lockout time phase U / Comp t_lock ph U		
	Access level: 4	Calculated: p0340 = 1	Data type: FloatingPoint32
	Can be changed: U, T	Scaling: -	Dyn. index: -
	Unit group: -	Unit selection: -	Func. diagram: -
	Min	Max	Factory setting
	0.00 [μs]	3.99 [μs]	0.00 [μs]
Description:	Sets the valve lockout time to compensate for phase U.		
Note:	The value is automatically calculated in the motor data identification routine.		
p1829	Compensation valve lockout time phase V / Comp t_lock ph V		
	Access level: 4	Calculated: p0340 = 1	Data type: FloatingPoint32
	Can be changed: U, T	Scaling: -	Dyn. index: -
	Unit group: -	Unit selection: -	Func. diagram: -
	Min	Max	Factory setting
	0.00 [μs]	3.99 [μs]	0.00 [μs]
Description:	Sets the valve lockout time to compensate for phase V.		
p1830	Compensation valve lockout time phase W / Comp t_lock ph W		
	Access level: 4	Calculated: p0340 = 1	Data type: FloatingPoint32
	Can be changed: U, T	Scaling: -	Dyn. index: -
	Unit group: -	Unit selection: -	Func. diagram: -
	Min	Max	Factory setting
	0.00 [μs]	3.99 [μs]	0.00 [μs]
Description:	Sets the valve lockout time to compensate for phase W.		
p1832	Dead time compensation current level / t_dead_comp I_lev		
	Access level: 4	Calculated: p0340 = 1	Data type: FloatingPoint32
	Can be changed: U, T	Scaling: -	Dyn. index: -
	Unit group: -	Unit selection: -	Func. diagram: -
	Min	Max	Factory setting
	0.0 [Arms]	10000.0 [Arms]	0.0 [Arms]
Description:	Sets the current level for the dead time compensation. Above the current level, the dead time - resulting from the converter switching delays - is compensated by a previously calculated constant value. If the relevant phase current setpoint falls below the absolute value defined by p1832, the corrective value for this phase is continuously reduced.		
Dependency:	The factory setting of p1832 is automatically set to 0.02 * rated drive converter current (r0207).		

p1900	Motor data identification and rotating measurement / MotID and rot meas		
	Access level: 2	Calculated: -	Data type: Integer16
	Can be changed: C(1), T	Scaling: -	Dyn. index: -
	Unit group: -	Unit selection: -	Func. diagram: -
	Min	Max	Factory setting
	0	3	0
Description:	<p>Sets the motor data identification and speed controller optimization.</p> <p>The motor identification should first be performed with the motor stationary (p1900 = 1, 2; also refer to p1910). Based on this, additional motor and control parameters can be determined using the motor data identification with the motor rotating (p1900 = 1, 3; also refer to p1960; not for p1300 < 20).</p> <p>p1900 = 0: Function inhibited.</p> <p>p1900 = 1: Sets p1910 = 1 and p1960 = 0, 1 depending on p1300 When the drive enable signals are present, a motor data identification routine is carried out at standstill with the next switch-on command. Current flows through the motor which means that it can align itself by up to a quarter of a revolution. With the following switch-on command, a rotating motor data identification routine is carried out - and in addition, a speed controller optimization by making measurements at different motor speeds.</p> <p>p1900 = 2: Sets p1910 = 1 and p1960 = 0 When the drive enable signals are present, a motor data identification routine is carried out at standstill with the next switch-on command. Current flows through the motor which means that it can align itself by up to a quarter of a revolution.</p> <p>p1900 = 3: Sets p1960 = 0, 1 depending on p1300 This setting should only be selected if the motor data identification was already carried out at standstill. When the drive enable signals are present, with the next switch-on command, a rotating motor data identification routine is carried out - and in addition, speed controller optimization by taking measurements at different motor speeds.</p>		
Value:	<p>0: Inhibited 1: Identifying motor data and optimizing the speed controller 2: Identifying motor data (at standstill) 3: Optimizing the speed controller (in rotating operation)</p>		
Dependency:	<p>Refer to: p1300, p1910, p1960 Refer to: A07980, A07981, F07983, F07984, F07985, F07986, F07988, F07990, A07991</p>		
Notice:	<p>p1900 = 3: This setting should only be selected if the motor data identification was already carried out at standstill. If there is a motor holding brake, it must be open (p1215 = 2). To permanently accept the determined settings they must be saved in a non-volatile fashion (p0971). During the rotating measurement it is not possible to save the parameter (p0971).</p>		
Note:	<p>The motor and control parameters of the vector control are only optimally set when both measurements are carried out (initially at standstill, and then with the motor rotating). The measurement with rotating motor is not performed for p1300 < 20 (U/f controls). An appropriate alarm is output when the parameter is set. The switch-on command must remain set during a measurement and after the measurement has been completed, the drive automatically resets it. The duration of the measurements can lie between 0.3 s and several minutes. This time is, for example, influenced by the motor size and the mechanical conditions. p1900 is automatically set to 0 after the motor data identification routine has been completed. If a reluctance motor has been parameterized, a pole position identification is carried out during the stationary measurement. As a consequence, faults that occur can also be assigned to the pole position identification. For U/f control (p1300), identification with speed controller optimization does not make sense (e.g. p1900 = 1).</p>		

p1901		Test pulse evaluation configuration / Test puls config			
Access level:	3	Calculated:	p0340 = 1	Data type: Unsigned32	
Can be changed:	T	Scaling:	-	Dyn. index: -	
Unit group:	-	Unit selection:	-	Func. diagram: -	
Min	-	Max	-	Factory setting	
				0000 bin	
Description:	Sets the configuration for the test pulse evaluation. Bit 00: Check for conductor-to-conductor short circuit once/always when the pulses are enabled. Bit 01: Check for ground fault once/always when the pulses are enabled. Bit 02: Activation of the tests selected using bit 00 and/or bit 01 each time the pulses are enabled				
Recommendation:	If the ground fault test is incorrectly initiated because the motor is not at a complete standstill, then the pulse cancellation delay time (p1228) should be increased.				
Bit field:	Bit	Signal name	1 signal	0 signal	FP
	00	Phase short-circuit test pulse active	Yes	No	-
	01	Ground fault detection test pulse active	Yes	No	-
	02	Test pulse at each pulse enable	Yes	No	-
Dependency:	The ground fault test is only possible when the motor is stationary, and is therefore only realized when flying restart is deactivated (p1200 = 0). Refer to: p0287				
Note:	If a conductor-to-conductor short-circuit is detected during the test, this is displayed in r1902.1. If a ground fault is detected during the test, this is displayed in r1902.2. For bit 02 = 0: If the test was successful once after POWER ON (see r1902.0), then it is not repeated. For bit 02 = 1: The test is not only performed after POWER ON, but also each time the pulses are enabled.				

r1902		Test pulse evaluation status / Test puls ev stat			
Access level:	4	Calculated:	-	Data type: Unsigned32	
Can be changed:	-	Scaling:	-	Dyn. index: -	
Unit group:	-	Unit selection:	-	Func. diagram: -	
Min	-	Max	-	Factory setting	
				-	
Description:	Displays the status of the test pulse evaluation.				
Bit field:	Bit	Signal name	1 signal	0 signal	FP
	00	Short-circuit test successfully performed	Yes	No	-
	01	Phase short-circuit detected	Yes	No	-
	02	Ground fault test successfully performed	Yes	No	-
	03	Ground fault detected	Yes	No	-
	04	Identification pulse width greater than the minimum pulse width	Yes	No	-
	05	Pulse frequency for short-circuit test requested	Yes	No	-
	06	Short-circuit test in power stack driver activated	Yes	No	-
	07	Short-circuit test pulse suppression active	Yes	No	-
	08	Motor phase interrupted	Yes	No	-
Note:	If the ground fault test was selected, but not successfully performed, then sufficient current was not be able to be established during the test pulses. For bit 04: A test pulse longer than one sampling time has occurred				

p1909[0...n]	Motor data identification control word / MotID STW		
	Access level: 3	Calculated: p0340 = 1	Data type: Unsigned32
	Can be changed: T	Scaling: -	Dyn. index: DDS, p0180
	Unit group: -	Unit selection: -	Func. diagram: -
	Min	Max	Factory setting
	-	-	0000 0000 0000 0000 0000 0000 0000 0000 0000 bin

Description: Sets the configuration for the motor data identification.

Bit field:	Bit	Signal name	1 signal	0 signal	FP
	00	Stator inductance estimate no measurement	Yes	No	-
	02	Rotor time constant estimate no measurement	Yes	No	-
	03	Leakage inductance estimate no measurement	Yes	No	-
	05	Determine Tr and Lsig evaluation in the time range	Yes	No	-
	06	Activate vibration damping	Yes	No	-
	07	Deactivate vibration detection	Yes	No	-
	11	Deactivate pulse measurement Lq Ld	Yes	No	-
	12	Deactivate rotor resistance Rr measurement	Yes	No	-
	14	Deactivate valve interlocking time measurement	Yes	No	-
	15	Determine only stator resistance, valve voltage fault, dead time	Yes	No	-
	16	Short motor identification (lower quality)	Yes	No	-
	17	Measurement without control parameter calculation	Yes	No	-
	18	After motID direct transition into operation	Yes	No	-
	19	After MotID automatically save results	Yes	No	-
	26	Measure with long cable	Yes	No	-

Note: The following applies to permanent-magnet synchronous motors:
 Without de-selection in bit 11, in the closed-loop control mode, the direct inductance LD and the quadrature inductance Lq are measured at a low current.
 When de-selecting with bit 11 or in the U/f mode, the stator inductance is measured at half the rated motor current.
 If the stator inductance is not measured but is to be estimated, then bit 0 should be set and bit 11 should be de-selected.
 Bit 19 = 1:
 All parameters are automatically saved after a successful motor data identification.
 If a speed controller optimization run is then selected, the parameters are only saved after this measurement has been completed.

p1910	Motor data identification selection / MotID selection		
	Access level: 3	Calculated: -	Data type: Integer16
	Can be changed: T	Scaling: -	Dyn. index: -
	Unit group: -	Unit selection: -	Func. diagram: -
	Min	Max	Factory setting
	0	28	0

Description: Sets the motor data identification routine.
 The motor data identification routine is carried out after the next switch-on command.
 p1910 = 1:
 All motor data and the drive converter characteristics are identified and then transferred to the following parameters: p0350, p0354, p0356, p0357, p0358, p0360, p1825, p1828, p1829, p1830
 After this, the control parameter p0340 = 3 is automatically calculated.
 p1910 = 20:
 Only for internal SIEMENS use.

Value:	0: Inhibited 1: Complete identification (ID) and acceptance of motor data 2: Complete identification (ID) of motor data without acceptance 20: Voltage vector input 21: Voltage vector input without filter 22: Rectangular voltage vector input without filter 23: Triangular voltage vector input without filter 24: Rectangular voltage vector input with filter 25: Triangular voltage vector input with filter 26: Enter voltage vector with DTC correction 27: Enter voltage vector with AVC 28: Enter voltage vector with DTC + AVC correction
Dependency:	"Quick commissioning" must be carried out (p0010 = 1, p3900 > 0) before executing the motor data identification routine! When selecting the motor data identification routine, the drive data set changeover is suppressed. Refer to: p1900 Refer to: F07990, A07991
Notice:	After the motor data identification (p1910 > 0) has been selected, alarm A07991 is output and a motor data identification routine is carried out as follows at the next switch-on command: - current flows through the motor and a voltage is present at the drive converter output terminals. - during the identification routine, the motor shaft can rotate through a maximum of half a revolution. - however, no torque torque is generated.
Note:	If there is a motor holding brake, it must be open (p1215 = 2). To permanently accept the determined settings they must be saved in a non-volatile fashion (p0971). When setting p1910, the following should be observed: 1. "With acceptance" means: The parameters specified in the description are overwritten with the identified values and therefore have an influence on the controller setting. 2. "Without acceptance" means: The identified parameters are only displayed in the range r1912 ... r1926 (service parameters). The controller settings remain unchanged. 3. For settings 27 and 28, the AVC configuration set using p1840 is active. The switch-on command must remain set during a measurement and after the measurement has been completed, the drive automatically resets it. The duration of the measurements can lie between 0.3 s and several minutes. This time is mainly influenced by the motor size. At the end of the motor data identification, p1910 is automatically set to 0, if only the stationary measurement is selected, then p1900 is also reset to 0, otherwise, the rotating measurement is activated.

p1911	Phases to be identified number / Ph to ident qty		
	Access level: 4	Calculated: -	Data type: Integer16
	Can be changed: T	Scaling: -	Dyn. index: -
	Unit group: -	Unit selection: -	Func. diagram: -
	Min	Max	Factory setting
	1	3	1
Description:	Sets the number of phases to be identified.		
Value:	1: 1 phase U 2: 2 phases U, V 3: 3 phases U, V, W		
Note:	When identifying with several phases, the accuracy increases and also the time it takes to make the measurement.		
r1912[0...2]	Identified stator resistance / R_stator ident		
	Access level: 4	Calculated: -	Data type: FloatingPoint32
	Can be changed: -	Scaling: -	Dyn. index: -
	Unit group: -	Unit selection: -	Func. diagram: -
	Min	Max	Factory setting
	- [ohm]	- [ohm]	- [ohm]
Description:	Displays the identified stator resistance.		

2 Parameters

2.2 List of parameters

Index:
 [0] = Phase U
 [1] = Phase V
 [2] = Phase W

r1913[0...2]	Identified rotor time constant / T_rotor ident		
	Access level: 4	Calculated: -	Data type: FloatingPoint32
	Can be changed: -	Scaling: -	Dyn. index: -
	Unit group: -	Unit selection: -	Func. diagram: -
	Min	Max	Factory setting
	- [ms]	- [ms]	- [ms]
Description:	Displays the identified rotor time constant.		
Index:	[0] = Phase U [1] = Phase V [2] = Phase W		

r1914[0...2]	Identified total leakage inductance / L_total_leak ident		
	Access level: 4	Calculated: -	Data type: FloatingPoint32
	Can be changed: -	Scaling: -	Dyn. index: -
	Unit group: -	Unit selection: -	Func. diagram: -
	Min	Max	Factory setting
	- [mH]	- [mH]	- [mH]
Description:	Displays the identified total leakage inductance.		
Index:	[0] = Phase U [1] = Phase V [2] = Phase W		

r1915[0...2]	Identified nominal stator inductance / L_stator ident		
	Access level: 4	Calculated: -	Data type: FloatingPoint32
	Can be changed: -	Scaling: -	Dyn. index: -
	Unit group: -	Unit selection: -	Func. diagram: -
	Min	Max	Factory setting
	- [mH]	- [mH]	- [mH]
Description:	Displays the nominal stator inductance identified.		
Index:	[0] = Phase U [1] = Phase V [2] = Phase W		

r1916[0...2]	Identified stator inductance 1 / L_stator 1 ident		
	Access level: 4	Calculated: -	Data type: FloatingPoint32
	Can be changed: -	Scaling: -	Dyn. index: -
	Unit group: -	Unit selection: -	Func. diagram: -
	Min	Max	Factory setting
	- [mH]	- [mH]	- [mH]
Description:	Displays the stator inductance identified for the 1st point of the saturation characteristic.		
Index:	[0] = Phase U [1] = Phase V [2] = Phase W		

r1917[0...2]	Identified stator inductance 2 / L_stator 2 ident		
	Access level: 4	Calculated: -	Data type: FloatingPoint32
	Can be changed: -	Scaling: -	Dyn. index: -
	Unit group: -	Unit selection: -	Func. diagram: -
	Min	Max	Factory setting
	- [mH]	- [mH]	- [mH]
Description:	Displays the stator inductance identified for the 2nd point of the saturation characteristic.		

Index: [0] = Phase U
[1] = Phase V
[2] = Phase W

r1918[0...2]	Identified stator inductance 3 / L_stator 3 ident		
	Access level: 4	Calculated: -	Data type: FloatingPoint32
	Can be changed: -	Scaling: -	Dyn. index: -
	Unit group: -	Unit selection: -	Func. diagram: -
	Min	Max	Factory setting
	- [mH]	- [mH]	- [mH]
Description:	Displays the stator inductance identified for the 3rd point of the saturation characteristic.		
Index:	[0] = Phase U [1] = Phase V [2] = Phase W		

r1919[0...2]	Identified stator inductance 4 / L_stator 4 ident		
	Access level: 4	Calculated: -	Data type: FloatingPoint32
	Can be changed: -	Scaling: -	Dyn. index: -
	Unit group: -	Unit selection: -	Func. diagram: -
	Min	Max	Factory setting
	- [mH]	- [mH]	- [mH]
Description:	Displays the stator inductance identified for the 4th point of the saturation characteristic.		
Index:	[0] = Phase U [1] = Phase V [2] = Phase W		

r1925[0...2]	Identified threshold voltage / U_threshold ident		
	Access level: 4	Calculated: -	Data type: FloatingPoint32
	Can be changed: -	Scaling: -	Dyn. index: -
	Unit group: -	Unit selection: -	Func. diagram: -
	Min	Max	Factory setting
	- [Vrms]	- [Vrms]	- [Vrms]
Description:	Displays the identified IGBT threshold voltage.		
Index:	[0] = Phase U [1] = Phase V [2] = Phase W		

r1926[0...2]	Identified effective valve lockout time / t_lock_valve id		
	Access level: 4	Calculated: -	Data type: FloatingPoint32
	Can be changed: -	Scaling: -	Dyn. index: -
	Unit group: -	Unit selection: -	Func. diagram: -
	Min	Max	Factory setting
	- [μs]	- [μs]	- [μs]
Description:	Displays the identified effective valve lockout time.		
Index:	[0] = Phase U [1] = Phase V [2] = Phase W		

r1927[0...2]	Identified rotor resistance / R_rotor ident		
	Access level: 4	Calculated: -	Data type: FloatingPoint32
	Can be changed: -	Scaling: -	Dyn. index: -
	Unit group: -	Unit selection: -	Func. diagram: -
	Min	Max	Factory setting
	- [ohm]	- [ohm]	- [ohm]
Description:	Displays identified rotor resistance (on separately excited synchronous motors: damping resistance).		

Index: [0] = Phase U
 [1] = Phase V
 [2] = Phase W

p1959[0...n] Rotating measurement configuration / Rot meas config

Access level: 3	Calculated: p0340 = 1	Data type: Unsigned16
Can be changed: T	Scaling: -	Dyn. index: DDS, p0180
Unit group: -	Unit selection: -	Func. diagram: -
Min	Max	Factory setting
-	-	0000 0000 0001 1110 bin

Description: Sets the configuration of the rotating measurement.

Bit field:

Bit	Signal name	1 signal	0 signal	FP
01	Saturation characteristic identification	Yes	No	-
02	Moment of inertia identification	Yes	No	-
03	Re-calculates the speed controller parameters	Yes	No	-
04	Speed controller optimization (vibration test)	Yes	No	-
11	Do not change the controller parameters during the measurement	Yes	No	-

Dependency: Refer to: F07988

Note: The following parameters are influenced for the individual optimization steps:
 Bit 01: p0320, p0360, p0362 ... p0369
 Bit 02: p0341, p0342
 Bit 03: p1400.0, p1458, p1459, p1463, p1470, p1472, p1496
 Bit 04: Dependent on p1960
 p1960 = 1, 3: p1400.0, p1458, p1459, p1470, p1472, p1496

p1960 Rotating measurement selection / Rot meas sel

Access level: 3	Calculated: -	Data type: Integer16
Can be changed: T	Scaling: -	Dyn. index: -
Unit group: -	Unit selection: -	Func. diagram: -
Min	Max	Factory setting
0	3	0

Description: Sets the rotating measurement.
 The rotating measurement is carried out after the next switch-on command.
 The setting possibilities of the parameter depend on the open-loop/closed-loop control mode (p1300).
 p1300 < 20 (U/f open-loop control):
 It is not possible to select rotating measurement or speed controller optimization.
 p1300 = 20, 22 (encoderless operation):
 Only rotating measurement or speed controller optimization can be selected in the encoderless mode.

Value: 0: Inhibited
 1: Rotating measurement in encoderless operation
 3: Speed controller optimization in encoderless operation

Dependency: Before the rotating measurement is carried out, the motor data identification routine (p1900, p1910, r3925) should have already been done.
 When selecting the rotating measurement, the drive data set changeover is suppressed.
 Refer to: p1300, p1900, p1959, p1967, r1968

Danger: For drives with a mechanical system that limits the distance moved, it must be ensured that this is not reached during the rotating measurement. If this is not the case, then it is not permissible that the measurement is carried out.

 **Notice:** If there is a motor holding brake, it must be open (p1215 = 2).
 To permanently accept the determined settings they must be saved in a non-volatile fashion (p0971).
 During the rotating measurement it is not possible to save the parameter (p0971).

Note: When the rotating measurement is activated, it is not possible to save the parameters (p0971).
 Parameter changes are automatically made for the rotating measurement (e.g. p1120); this is the reason that up to the end of the measurement, and if no faults are present, no manual changes should be made.
 The ramp-up and ramp-down times (p1120, p1121) are limited, for the rotating measurement, to 900 s.

p1961	Saturation characteristic speed to determine / Sat_char n determ		
	Access level: 3	Calculated: -	Data type: FloatingPoint32
	Can be changed: U, T	Scaling: -	Dyn. index: -
	Unit group: -	Unit selection: -	Func. diagram: -
	Min	Max	Factory setting
	26 [%]	75 [%]	40 [%]
Description:	Sets the speed to determine the saturation characteristic. The percentage value is referred to p0310 (rated motor frequency).		
Dependency:	Refer to: p0310, p1959 Refer to: F07983		
Note:	The saturation characteristics should be determined at an operating point with the lowest possible load.		
p1965	Speed_ctrl_opt speed / n_opt speed		
	Access level: 3	Calculated: -	Data type: FloatingPoint32
	Can be changed: U, T	Scaling: -	Dyn. index: -
	Unit group: -	Unit selection: -	Func. diagram: -
	Min	Max	Factory setting
	10 [%]	75 [%]	40 [%]
Description:	Sets the speed for the identification of the moment of inertia and the vibration test. Induction motor: The percentage value is referred to p0310 (rated motor frequency). Synchronous motor: The percentage value is referred to the minimum from p0310 (rated motor frequency) and p1082 (maximum speed).		
Dependency:	Refer to: p0310, p1959 Refer to: F07984, F07985		
Note:	In order to calculate the inertia, sudden speed changes are carried out - the specified value corresponds to the lower speed setpoint. This value is increased by 20 % for the upper speed value. The q leakage inductance (refer to p1959.5) is determined at zero speed and at 50 % of p1965 - however, with a maximum output frequency of 15 Hz and at a minimum of 10% of the rated motor speed.		
p1967	Speed_ctrl_opt dynamic factor / n_opt dyn_factor		
	Access level: 3	Calculated: p0340 = 1	Data type: FloatingPoint32
	Can be changed: U, T	Scaling: -	Dyn. index: -
	Unit group: -	Unit selection: -	Func. diagram: -
	Min	Max	Factory setting
	1 [%]	400 [%]	100 [%]
Description:	Sets the dynamic response factor for speed controller optimization. After optimization, the dynamic response achieved is displayed in r1968.		
Dependency:	Refer to: p1959, r1968 Refer to: F07985		
Note:	For a rotating measurement, this parameter can be used to optimize the speed controller. p1967 = 100 % --> speed controller optimization according to a symmetric optimum. p1967 > 100 % --> optimization with a higher dynamic response (Kp higher, Tn lower). If the actual dynamic response (see r1968) is significantly reduced with respect to the required dynamic response (p1967), then this can be as a result of mechanical load oscillations. If, in spite of this load behavior, a higher dynamic response is required, then the oscillation test (p1959.4 = 0) should be deactivated and the measurement repeated.		

r1968	Speed_ctrl_opt dynamic factor actual / n_opt dyn_fact act		
	Access level: 3	Calculated: -	Data type: FloatingPoint32
	Can be changed: -	Scaling: -	Dyn. index: -
	Unit group: -	Unit selection: -	Func. diagram: -
	Min	Max	Factory setting
	- [%]	- [%]	- [%]
Description:	Displays the dynamic factor which is actually achieved for the vibration test		
Dependency:	Refer to: p1959, p1967 Refer to: F07985		
Note:	This dynamic factor only refers to the control mode of the speed controller set in p1960.		
r1969	Speed_ctrl_opt moment of inertia determined / n_opt M_inert det		
	Access level: 4	Calculated: -	Data type: FloatingPoint32
	Can be changed: -	Scaling: -	Dyn. index: -
	Unit group: 25_1	Unit selection: p0100	Func. diagram: -
	Min	Max	Factory setting
	- [kgm ²]	- [kgm ²]	- [kgm ²]
Description:	Displays the determined moment of inertia of the drive. After it has been determined, the value is transferred to p0341, p0342.		
Dependency:	IEC drives (p0100 = 0): unit kg m ² NEMA drives (p0100 = 1): unit lb ft ² Refer to: p0341, p0342, p1959 Refer to: F07984		
r1970[0...1]	Speed_ctrl_opt vibration test vibration frequency determined / n_opt f_vib det		
	Access level: 4	Calculated: -	Data type: FloatingPoint32
	Can be changed: -	Scaling: -	Dyn. index: -
	Unit group: -	Unit selection: -	Func. diagram: -
	Min	Max	Factory setting
	- [Hz]	- [Hz]	- [Hz]
Description:	Displays the vibration frequencies determined by the vibration test.		
Index:	[0] = Frequency low [1] = Frequency high		
Dependency:	Refer to: p1959 Refer to: F07985		
p1974	Speed_ctrl_opt saturation characteristic rotor flux maximum / n_opt rot_fl max		
	Access level: 4	Calculated: p0340 = 1	Data type: FloatingPoint32
	Can be changed: U, T	Scaling: -	Dyn. index: -
	Unit group: -	Unit selection: -	Func. diagram: -
	Min	Max	Factory setting
	104 [%]	120 [%]	115 [%]
Description:	Sets the maximum flux setpoint to measure the saturation characteristic.		

p1980[0...n]	PolID technique / PolID technique		
	Access level: 3	Calculated: p0340 = 1,3	Data type: Integer16
	Can be changed: U, T	Scaling: -	Dyn. index: DDS, p0180
	Unit group: -	Unit selection: -	Func. diagram: -
	Min	Max	Factory setting
	1	12	4
Description:	Sets the pole position identification technique. p1980 = 1, 8: The current magnitude is set using p0329. p1980 = 4, 6: The current magnitude of the first measurement section is set using p0325, the second using p0329. p1980 = 10: The rated motor current is impressed to align. The current magnitudes are limited to the rated power unit values.		
Value:	1: Voltage pulsing 1st harmonics 4: Voltage pulsing 2-stage 6: Voltage pulsing 2-stage inverse 8: Voltage pulsing 2nd harmonic, inverse 10: DC current injection 12: Rotor position sensing VSM for SESM with incremental encoder		
Dependency:	When commissioning a catalog motor, the technique is automatically selected depending on the motor type being used. In the simulation mode, the parameter cannot be written into. Refer to: p0325, p0329, p1780 Refer to: F07969		
Note:	Voltage pulse technique (p1980 = 1, 4, 6, 8) cannot be applied to separately-excited synchronous motors (p0300 = 5) and for for operation with sine-wave output filters (p0230).		
r1984	PolID angular difference / PolID ang diff		
	Access level: 4	Calculated: -	Data type: FloatingPoint32
	Can be changed: -	Scaling: -	Dyn. index: -
	Unit group: -	Unit selection: -	Func. diagram: -
	Min	Max	Factory setting
	- [°]	- [°]	- [°]
Description:	Displays the angular difference between the actual electrical commutation angle and the angle determined by the pole position identification.		
Dependency:	Refer to: p0325, p0329, p1980, r1985, r1987, r1992		
Note:	When the pole position identification routine is executed several times, the spread of the measured values can be determined using this value. At the same position, the spread should be less than 2 degrees electrical.		
r1985	PolID saturation curve / PolID sat_char		
	Access level: 4	Calculated: -	Data type: FloatingPoint32
	Can be changed: -	Scaling: -	Dyn. index: -
	Unit group: -	Unit selection: -	Func. diagram: -
	Min	Max	Factory setting
	- [Arms]	- [Arms]	- [Arms]
Description:	Displays the saturation characteristic of the pole position identification routine (saturation technique). Displays the current characteristic of the pole position identification routine (elasticity technique).		
Dependency:	Refer to: p0325, p0329, p1980, r1984, r1987, r1992		
Note:	PolID: Pole position identification Regarding the saturation technique: The values for the characteristic of the last saturation-based pole position identification routine are output every 1 ms in order to record signals (e.g. trace).		

r1987	PolID trigger characteristic / PolID trig_char		
	Access level: 4	Calculated: -	Data type: FloatingPoint32
	Can be changed: -	Scaling: -	Dyn. index: -
	Unit group: -	Unit selection: -	Func. diagram: -
	Min	Max	Factory setting
	- [%]	- [%]	- [%]
Description:	<p>Displays the trigger characteristic of the pole position identification routine.</p> <p>The values for the characteristic of the last pole position identification routine are output every 1 ms in order to record signals (e.g. trace).</p> <p>The values for trigger characteristic and saturation characteristic are always output in synchronism from a time perspective.</p>		
Dependency:	Refer to: p0325, p0329, p1980, r1984, r1985, r1992		
Note:	<p>PolID: Pole position identification</p> <p>The following information and data can be taken from the trigger characteristic.</p> <ul style="list-style-type: none"> - the value -100% marks the angle at the start of the measurement. - the value +100 % marks the commutation angle determined from the pole position identification routine. 		

r1992.0...15	CO/BO: PolID diagnostics / PolID diag				
	Access level: 3	Calculated: -	Data type: Unsigned16		
	Can be changed: -	Scaling: -	Dyn. index: -		
	Unit group: -	Unit selection: -	Func. diagram: -		
	Min	Max	Factory setting		
	-	-	-		
Description:	Display and BICO output for the diagnostics information of the pole position identification (polID)				
Bit field:	Bit	Signal name	1 signal	0 signal	FP
	00	Critical encoder fault occurred	Yes	No	-
	02	Encoder parking active	Yes	No	-
	05	Encoder fault Class 1	Yes	No	-
	06	Encoder fault Class 2	Yes	No	-
	07	Pole position identification for encoder carried out	Yes	No	-
	08	Fine synchronization carried out	Yes	No	-
	09	Coarse synchronization carried out	Yes	No	-
	10	Commutation information available	Yes	No	-
	11	Speed information available	Yes	No	-
	12	Position information available	Yes	No	-
	15	Zero mark passed	Yes	No	-
Dependency:	Refer to: p0325, p0329, p1980, r1984, r1985, r1987				
Note:	<p>The data of p1992 are updated in a 4 ms cycle.</p> <p>Fast changes of the encoder status word bits can be better investigated using p7830 and following.</p> <p>PolID: Pole position identification</p>				

p1999[0...n]	Ang. commutation offset calibr. and PolID scaling / Com_ang_offs scal		
	Access level: 4	Calculated: -	Data type: FloatingPoint32
	Can be changed: U, T	Scaling: -	Dyn. index: DDS, p0180
	Unit group: -	Unit selection: -	Func. diagram: -
	Min	Max	Factory setting
	10 [%]	5000 [%]	100 [%]
Description:	Sets the scaling for the runtime of the pole position identification technique in which the current is injected.		
Dependency:	Refer to: p0341, p0342		
Caution:	For p1999 > 100 % (setting large moments of inertia) the following applies:		
	There is no locked rotor monitoring (F07970 fault value 2).		
Note:	For high moments of inertia, it is practical to scale the runtime of the calibration higher.		

p2000	Reference speed reference frequency / n_ref f_ref		
	Access level: 2	Calculated: p0340 = 1	Data type: FloatingPoint32
	Can be changed: T	Scaling: -	Dyn. index: -
	Unit group: -	Unit selection: -	Func. diagram: -
	Min	Max	Factory setting
	6.00 [rpm]	210000.00 [rpm]	1500.00 [rpm]
Description:	Sets the reference quantity for speed and frequency. All speeds or frequencies specified as relative value are referred to this reference quantity. The reference quantity corresponds to 100% or 4000 hex (word) or 4000 0000 hex (double word). The following applies: Reference frequency (in Hz) = reference speed (in ((rpm) / 60) x pole pair number)		
Dependency:	This parameter is only updated during the automatic calculation (p0340 = 1, p3900 > 0) if motor commissioning was carried out beforehand for drive data set zero. This means that the parameter is not locked against overwriting using p0573 = 1. Refer to: p2001, p2002, p2003, r2004, r3996		
Notice:	When the reference speed / reference frequency is changed, short-term communication interruptions may occur.		
Note:	If a BICO interconnection is established between different physical quantities, then the particular reference quantities are used as internal conversion factor. Example 1: The signal of an analog input (e.g. r0755[0]) is connected to a speed setpoint (e.g. p1070[0]). The actual percentage input value is cyclically converted into the absolute speed setpoint using the reference speed (p2000). Example 2: The setpoint from PROFIBUS (r2050[1]) is connected to a speed setpoint (e.g. p1070[0]). The actual input value is cyclically converted into a percentage value via the pre-specified scaling 4000 hex. This percentage value is converted to the absolute speed setpoint via reference speed (p2000).		
p2001	Reference voltage / Reference voltage		
	Access level: 3	Calculated: p0340 = 1	Data type: FloatingPoint32
	Can be changed: T	Scaling: -	Dyn. index: -
	Unit group: -	Unit selection: -	Func. diagram: -
	Min	Max	Factory setting
	10 [Vrms]	100000 [Vrms]	1000 [Vrms]
Description:	Sets the reference quantity for voltages. All voltages specified as relative value are referred to this reference quantity. This also applies for direct voltage values (= rms value) like the DC link voltage. The reference quantity corresponds to 100% or 4000 hex (word) or 4000 0000 hex (double word). Note: This reference quantity also applies to direct voltage values. It is not interpreted as rms value, but as DC voltage value.		
Dependency:	p2001 is only updated during automatic calculation (p0340 = 1, p3900 > 0) if motor commissioning has been carried out first for drive data set zero and as a result overwriting of the parameter has not been blocked by setting p0573 = 1. Refer to: r3996		
Notice:	When the reference voltage is changed, short-term communication interruptions may occur.		
Note:	If a BICO interconnection is established between different physical quantities, then the particular reference quantities are used as internal conversion factor. For infeed units, the parameterized device supply voltage (p0210) is pre-assigned as the reference quantity. Example: The actual value of the DC link voltage (r0070) is connected to a test socket (e.g. p0771[0]). The actual voltage value is cyclically converted into a percentage of the reference voltage (p2001) and output according to the parameterized scaling.		

p2002	Reference current / I_ref		
	Access level: 3	Calculated: p0340 = 1	Data type: FloatingPoint32
	Can be changed: T	Scaling: -	Dyn. index: -
	Unit group: -	Unit selection: -	Func. diagram: -
	Min	Max	Factory setting
	0.10 [Arms]	100000.00 [Arms]	100.00 [Arms]
Description:	Sets the reference quantity for currents. All currents specified as relative value are referred to this reference quantity. The reference quantity corresponds to 100% or 4000 hex (word) or 4000 0000 hex (double word).		
Dependency:	This parameter is only updated during the automatic calculation (p0340 = 1, p3900 > 0) if motor commissioning was carried out beforehand for drive data set zero. This means that the parameter is not locked against overwriting using p0573 = 1. Refer to: r3996		
Notice:	If various DDS are used with different motor data, then the reference quantities remain the same as these are not changed over with the DDS. The resulting conversion factor must be taken into account. Example: p2002 = 100 A Reference quantity 100 A corresponds to 100 % p0305[0] = 100 A Rated motor current 100 A for MDS0 in DDS0 --> 100 % corresponds to 100 % of the rated motor current p0305[1] = 50 A Rated motor current 50 A for MDS1 in DDS1 --> 100 % corresponds to 200 % of the rated motor current When the reference current is changed, short-term communication interruptions may occur.		
Note:	Pre-assigned value is p0640. If a BICO interconnection is established between different physical quantities, then the particular reference quantities are used as internal conversion factor. For infeed units, the rated line current, which is obtained from the rated power and parameterized rated line supply voltage (p2002 = r0206 / p0210 / 1.73) is pre-assigned as the reference quantity. Example: The actual value of a phase current (r0069[0]) is connected to a test socket (e.g. p0771[0]). The actual current value is cyclically converted into a percentage of the reference current (p2002) and output according to the parameterized scaling.		
p2003	Reference torque / M_ref		
	Access level: 3	Calculated: p0340 = 1	Data type: FloatingPoint32
	Can be changed: T	Scaling: -	Dyn. index: -
	Unit group: 7_2	Unit selection: p0505	Func. diagram: -
	Min	Max	Factory setting
	0.01 [Nm]	20000000.00 [Nm]	1.00 [Nm]
Description:	Sets the reference quantity for torque. All torques specified as relative value are referred to this reference quantity. The reference quantity corresponds to 100% or 4000 hex (word) or 4000 0000 hex (double word).		
Dependency:	This parameter is only updated during the automatic calculation (p0340 = 1, p3900 > 0) if motor commissioning was carried out beforehand for drive data set zero. This means that the parameter is not locked against overwriting using p0573 = 1. Refer to: r3996		
Notice:	When the reference torque is changed, short-term communication interruptions may occur.		
Note:	Preassigned value is 2 * p0333. If a BICO interconnection is established between different physical quantities, then the particular reference quantities are used as internal conversion factor. Example: The actual value of the total torque (r0079) is connected to a test socket (e.g. p0771[0]). The actual torque is cyclically converted into a percentage of the reference torque (p2003) and output according to the parameterized scaling.		

r2004	Reference power / P_ref		
	Access level: 3	Calculated: -	Data type: FloatingPoint32
	Can be changed: -	Scaling: -	Dyn. index: -
	Unit group: 14_10	Unit selection: p0505	Func. diagram: -
	Min	Max	Factory setting
	- [kW]	- [kW]	- [kW]
Description:	Displays the reference quantity for power. All power ratings specified as relative value are referred to this reference quantity. The reference quantity corresponds to 100% or 4000 hex (word) or 4000 0000 hex (double word).		
Dependency:	This value is calculated as follows: Infeed: Calculated from voltage times current. Closed-loop control: Calculated from torque times speed. Refer to: p2000, p2001, p2002, p2003		
Note:	If a BICO interconnection is established between different physical quantities, then the particular reference quantities are used as internal conversion factor. The reference power is calculated as follows: - $2 * P_i * \text{reference speed} / 60 * \text{reference torque (motor)}$ - $\text{reference voltage} * \text{reference current} * \text{root}(3) \text{ (infeed)}$		
p2005	Reference angle / Reference angle		
	Access level: 4	Calculated: p0340 = 1	Data type: FloatingPoint32
	Can be changed: T	Scaling: -	Dyn. index: -
	Unit group: -	Unit selection: -	Func. diagram: -
	Min	Max	Factory setting
	90.00 [°]	180.00 [°]	90.00 [°]
Description:	Sets the reference quantity for angle. All angles specified as relative value are referred to this reference quantity. The reference quantity corresponds to 100% or 4000 hex (word) or 4000 0000 hex (double word).		
Dependency:	This parameter is only updated during the automatic calculation (p0340 = 1, p3900 > 0) if motor commissioning was carried out beforehand for drive data set zero. This means that the parameter is not locked against overwriting using p0573 = 1.		
Note:	If a BICO interconnection is established between different physical quantities, then the particular reference quantities are used as internal conversion factor.		
p2006	Reference temperature / Ref temp		
	Access level: 3	Calculated: p0340 = 1	Data type: FloatingPoint32
	Can be changed: T	Scaling: -	Dyn. index: -
	Unit group: 21_1	Unit selection: p0505	Func. diagram: -
	Min	Max	Factory setting
	50.00 [°C]	300.00 [°C]	100.00 [°C]
Description:	Sets the reference quantity for temperature. All temperatures specified as relative value are referred to this reference quantity. The reference quantity corresponds to 100% or 4000 hex (word) or 4000 0000 hex (double word).		
p2007	Reference acceleration / a_ref		
	Access level: 4	Calculated: p0340 = 1	Data type: FloatingPoint32
	Can be changed: T	Scaling: -	Dyn. index: -
	Unit group: -	Unit selection: -	Func. diagram: -
	Min	Max	Factory setting
	0.01 [rev/s ²]	500000.00 [rev/s ²]	0.01 [rev/s ²]
Description:	Sets the reference quantity for acceleration rates. All acceleration rates specified as relative value are referred to this reference quantity. The reference quantity corresponds to 100% or 4000 hex (word) or 4000 0000 hex (double word).		

2 Parameters

2.2 List of parameters

Dependency: This parameter is only updated during the automatic calculation ($p0340 = 1$, $p3900 > 0$) if motor commissioning was carried out beforehand for drive data set zero. This means that the parameter is not locked against overwriting using $p0573 = 1$.

Note: If a BICO interconnection is established between different physical quantities, then the particular reference quantities are used as internal conversion factor.
The reference acceleration is calculated as follows:
 $p2007 = p2000 / 1$ [s]

p2010	Comm IF baud rate / Comm baud		
	Access level: 3	Calculated: -	Data type: Integer16
	Can be changed: T	Scaling: -	Dyn. index: -
	Unit group: -	Unit selection: -	Func. diagram: -
	Min	Max	Factory setting
	6	12	12
Description:	Sets the baud rate for the commissioning interface (USS, RS232).		
Value:	6: 9600 baud 7: 19200 baud 8: 38400 baud 9: 57600 baud 10: 76800 baud 11: 93750 baud 12: 115200 baud		
Note:	COMM-IF: Commissioning interface The parameter is not influenced by setting the factory setting.		

p2011	Comm IF address / Comm add		
	Access level: 3	Calculated: -	Data type: Unsigned16
	Can be changed: T	Scaling: -	Dyn. index: -
	Unit group: -	Unit selection: -	Func. diagram: -
	Min	Max	Factory setting
	0	31	2
Description:	Sets the address for the commissioning interface (USS, RS232).		
Note:	The parameter is not influenced by setting the factory setting.		

p2012[0...1]	AS-i address / AS-i address		
G115D ASI	Access level: 3	Calculated: -	Data type: Unsigned8
	Can be changed: T	Scaling: -	Dyn. index: -
	Unit group: -	Unit selection: -	Func. diagram: 9430
	Min	Max	Factory setting
	0	63	0
Description:	Sets the address for the AS-i slaves. Dual slave: - index 0: address for slave 1, profile 7.A.5 - index 1: address for slave 2, profile 7.A.E Single slave: - index 0: reserved - index 1: address for slave 2, profile 7.F.E The address can be set in the following ways: - AS-i address programmer - AS-i master - parameter p2012		
Index:	[0] = Slave 1 [1] = Slave 2		
Dependency:	Parameter p2012 can be changed in the online state. Refer to: p2013, p2014, r2015		

Note: AS-i: Actuator Sensor Interface
 After this parameter is changed, the AS-i interface is reset in order to load the new address.
 Possible values for dual slave:
 0 ... 31 for A address
 33 ... 63 for B address
 Possible values for single slave:
 0 ... 31 for A address

p2013**AS-i mode / AS-i mode**

G115D ASI	Access level: 3	Calculated: -	Data type: Integer16
	Can be changed: T	Scaling: -	Dyn. index: -
	Unit group: -	Unit selection: -	Func. diagram: 9430
	Min	Max	Factory setting
	0	2	0

Description: Sets the single slave or dual slave mode for AS-i.

Value: 0: Single slave with A addressing
 2: Dual slave with AB addressing

Dependency: Refer to: p2012, p2014, r2015
 Refer to: A01991

Notice: If this parameter is changed the AS-i address is reset to 0.
 If the parameter value does not correspond to the value of p0015, then alarm A01991 is output.
 The parameter should be saved after changing (e.g. run the "Copy RAM to ROM" function).

Note: After this parameter is changed, the AS-i interface is reset in order to load the new profile.
 AS-i: Actuator Sensor Interface

p2014[0...1]**AS-i ID1 profile / AS-i ID1 profile**

G115D ASI	Access level: 3	Calculated: -	Data type: Unsigned8
	Can be changed: T	Scaling: -	Dyn. index: -
	Unit group: -	Unit selection: -	Func. diagram: -
	Min	Max	Factory setting
	0	15	0

Description: Sets the ID1 profile for AS-i slaves.
 Dual slave:
 - index 0: ID1 for slave 1, profile 7.A.5
 - index 1: ID1 for slave 2, profile 7.A.E
 Single slave:
 - index 0: reserved
 - index 1: ID1 for slave 1, profile 7.F.E
 The profile can be set in the following ways:
 - AS-i address programmer
 - AS-i master
 - parameter p2014

Index: [0] = Slave 1
 [1] = Slave 2

Dependency: Parameter p2014 can be changed in the online state.
 Refer to: p2012, p2013, r2015

Note: AS-i: Actuator Sensor Interface
 After this parameter is changed, the AS-i interface is reset in order to load the new profile.
 Possible ID1 values:
 0 ... 7 for dual slave
 0 ... 15 for single slave

2 Parameters

2.2 List of parameters

r2015[0...4]	CO: AS-i state / AS-i state		
G115D ASI	Access level: 3	Calculated: -	Data type: Unsigned32
	Can be changed: -	Scaling: -	Dyn. index: -
	Unit group: -	Unit selection: -	Func. diagram: 9430
	Min	Max	Factory setting
	-	-	-
Description:	Display and connector output for the state of AS-i.		
Index:	[0] = AS-i status [1] = Count module running [2] = Counter telegrams received from master [3] = Counter valid telegrams received from master [4] = Counter telegrams CRC error		
Dependency:	Refer to: p2012, p2013, p2014		
Note:	AS-i: Actuator Sensor Interface For index [0]: Bit 0: AS-i processor: error in EEPROM data Bit 1: AS-i synchronization error Bit 2: AS-i slave not ready Bit 3: AS-i processor: CRC error Bit 4: incorrect telegram ID Bit 5: No telegram received Bit 6: Acyclic data incomplete Bit 7: Reserved Bit 8: Acyclic data are being received Bit 9: Acyclic data are being sent Bit 10 ... 12: Reserved Bit 13: Ready for switch on Bit 14 ... 31: Reserved		
p2016[0...3]	CI: Comm IF USS PZD send word / Comm USS send word		
	Access level: 3	Calculated: -	Data type: U32 / Integer16
	Can be changed: U, T	Scaling: 4000H	Dyn. index: -
	Unit group: -	Unit selection: -	Func. diagram: -
	Min	Max	Factory setting
	-	-	0
Description:	Selects the PZD (actual values) to be sent via the commissioning interface USS. The actual values are displayed on an intelligent operator panel (IOP).		
Index:	[0] = PZD 1 [1] = PZD 2 [2] = PZD 3 [3] = PZD 4		
r2019[0...7]	Comm IF error statistics / Comm err		
	Access level: 4	Calculated: -	Data type: Unsigned32
	Can be changed: -	Scaling: -	Dyn. index: -
	Unit group: -	Unit selection: -	Func. diagram: -
	Min	Max	Factory setting
	-	-	-
Description:	Displays the receive errors at the commissioning interface (USS, RS232).		

Index:
 [0] = Number of error-free telegrams
 [1] = Number of rejected telegrams
 [2] = Number of framing errors
 [3] = Number of overrun errors
 [4] = Number of parity errors
 [5] = Number of starting character errors
 [6] = Number of checksum errors
 [7] = Number of length errors

r2028[0...3] AS-i firmware version / AS-i FW version

G115D ASI	Access level: 3	Calculated: -	Data type: Unsigned16
	Can be changed: -	Scaling: -	Dyn. index: -
	Unit group: -	Unit selection: -	Func. diagram: -
	Min	Max	Factory setting
	0	65535	-

Description: Displays the actual firmware version of AS-i

Index:
 [0] = Firmware version
 [1] = Firmware patch/hot fix
 [2] = Firmware date (day/month)
 [3] = Firmware date (year)

Dependency: Refer to: r0197, r0198

Note: AS-i: Actuator Sensor Interface

For index [0, 1]:

Both indices together form the complete firmware version.

Example:

r2028[0] = 1020

r2028[1] = 3040

Complete firmware version: 10.20.30.40

p2030 Field bus interface protocol selection / Field bus protocol

G115D ASI	Access level: 1	Calculated: -	Data type: Integer16
	Can be changed: T	Scaling: -	Dyn. index: -
	Unit group: -	Unit selection: -	Func. diagram: 9310
	Min	Max	Factory setting
	0	11	11

Description: Sets the communication protocol for the field bus interface.

Value:
 0: No protocol
 11: AS-i

Note: Changes only become effective after POWER ON.

The parameter is not influenced by setting the factory setting.

p2030 Field bus interface protocol selection / Field bus protocol

G115D PN	Access level: 1	Calculated: -	Data type: Integer16
	Can be changed: T	Scaling: -	Dyn. index: -
	Unit group: -	Unit selection: -	Func. diagram: 9310
	Min	Max	Factory setting
	0	10	7

Description: Sets the communication protocol for the field bus interface.

Value:
 0: No protocol
 7: PROFINET
 10: EtherNet/IP

Note: Changes only become effective after POWER ON.

The parameter is not influenced by setting the factory setting.

r2032	Master control control word effective / PCtrl STW eff				
	Access level: 3	Calculated: -	Data type: Unsigned16		
	Can be changed: -	Scaling: -	Dyn. index: -		
	Unit group: -	Unit selection: -	Func. diagram: -		
	Min	Max	Factory setting		
	-	-	-		
Description:	Displays the effective control word 1 (STW1) of the drive for the master control.				
Bit field:	Bit	Signal name	1 signal	0 signal	FP
	00	ON/OFF1	Yes	No	-
	01	OC / OFF2	Yes	No	-
	02	OC / OFF3	Yes	No	-
	03	Enable operation	Yes	No	-
	04	Enable ramp-function generator	Yes	No	-
	05	Start ramp-function generator	Yes	No	-
	06	Enable speed setpoint	Yes	No	-
	07	Acknowledge fault	Yes	No	-
	08	Jog bit 0	Yes	No	3030
	09	Jog bit 1	Yes	No	3030
	10	Master control by PLC	Yes	No	-
Notice:	The master control only influences control word 1 and speed setpoint 1. Other control word/setpoints can be transferred from another automation device.				
Note:	OC: Operating condition				

r2033	CO: Fieldbus interface setpoint scaling / Fieldbus setp_scal			
G115D ASI	Access level: 3	Calculated: -	Data type: FloatingPoint32	
	Can be changed: -	Scaling: PERCENT	Dyn. index: -	
	Unit group: -	Unit selection: -	Func. diagram: -	
	Min	Max	Factory setting	
	- [%]	- [%]	- [%]	
Description:	Display and connector output for the setpoint scaling of the fieldbus interface.			

p2037	PROFIdrive STW1.10 = 0 mode / PD STW1.10=0			
G115D PN	Access level: 3	Calculated: -	Data type: Integer16	
	Can be changed: T	Scaling: -	Dyn. index: -	
	Unit group: -	Unit selection: -	Func. diagram: -	
	Min	Max	Factory setting	
	0	2	0	
Description:	Sets the processing mode for PROFIdrive STW1.10 "master control by PLC". Generally, control word 1 is received with the first receive word (PZD1) (this is in conformance to the PROFIdrive profile). The behavior of STW1.10 = 0 corresponds to that of the PROFIdrive profile. For other applications that deviate from this, the behavior can be adapted using this particular parameter.			
Value:	0: Freeze setpoints and continue to process sign-of-life 1: Freeze setpoints and sign-of-life 2: Do not freeze setpoints			
Recommendation:	Do not change the setting p2037 = 0.			
Note:	If the STW1 is not transferred according to the PROFIdrive with PZD1 (with bit 10 "master control by PLC"), then p2037 should be set to 2.			

p2038	PROFIdrive STW/ZSW interface mode / PD STW/ZSW IF mode			
G115D PN	Access level: 3	Calculated: -	Data type: Integer16	
	Can be changed: T	Scaling: -	Dyn. index: -	
	Unit group: -	Unit selection: -	Func. diagram: -	
	Min	Max	Factory setting	
	0	2	0	
Description:	Sets the interface mode of the PROFIdrive control words and status words. When selecting a telegram via p0922 (p2079), this parameter influences the device-specific assignment of the bits in the control and status words.			
Value:	0: SINAMICS 2: VIK-NAMUR			
Dependency:	Refer to: p0922, p2079			
Notice:	The parameter may be protected as a result of p0922 or p2079 and cannot be changed.			
Note:	- For p0922 (p2079) = 1, 350 ... 999, p2038 is automatically set to 0. - For p0922 (p2079) = 20, p2038 is automatically set to 2. It is not then possible to change p2038.			
p2039	Select debug monitor interface / Debug monit select			
	Access level: 4	Calculated: -	Data type: Unsigned16	
	Can be changed: U, T	Scaling: -	Dyn. index: -	
	Unit group: -	Unit selection: -	Func. diagram: -	
	Min	Max	Factory setting	
	0	3	0	
Description:	The serial interface for the debug monitor is COM1 (commissioning interface, RS232) or COM2 (fieldbus interface, RS485). Value = 0: Deactivated Value = 1: COM1, commissioning protocol is deactivated Value = 2: COM2, field bus is deactivated Value = 3: Reserved			
Note:	Value = 2 is only possible for Control Units with RS485 as a field bus interface.			
p2040	Fieldbus interface monitoring time / Fieldbus t_monit			
G115D ASI	Access level: 3	Calculated: -	Data type: FloatingPoint32	
	Can be changed: U, T	Scaling: -	Dyn. index: -	
	Unit group: -	Unit selection: -	Func. diagram: 9310	
	Min	Max	Factory setting	
	0 [ms]	1999999 [ms]	500 [ms]	
Description:	Sets the monitoring time to monitor the process data received via the fieldbus interface. If no process data is received within this time, then an appropriate message is output.			
Dependency:	Refer to: F01910			
Note:	p2040 = 0: Monitoring is deactivated.			
r2043.0...2	BO: PROFIdrive PZD state / PD PZD state			
G115D PN	Access level: 3	Calculated: -	Data type: Unsigned8	
	Can be changed: -	Scaling: -	Dyn. index: -	
	Unit group: -	Unit selection: -	Func. diagram: 2410	
	Min	Max	Factory setting	
	-	-	-	
Description:	Displays the PROFIdrive PZD state.			
Bit field:	Bit	Signal name	1 signal	0 signal
	00	Setpoint failure	Yes	No
	02	Fieldbus operation	Yes	No

2 Parameters

2.2 List of parameters

Dependency: Refer to: p2044
Note: When using the "setpoint failure" signal, the bus can be monitored and an application-specific response triggered when the setpoint fails.

p2044	PROFIdrive fault delay / PD fault delay		
G115D PN	Access level: 3	Calculated: -	Data type: FloatingPoint32
	Can be changed: U, T	Scaling: -	Dyn. index: -
	Unit group: -	Unit selection: -	Func. diagram: 2410
	Min	Max	Factory setting
	0 [s]	100 [s]	0 [s]
Description:	Sets the delay time to initiate fault F01910 after a setpoint failure. The time until the fault is initiated can be used by the application. This means that it is possible to respond to the failure while the drive is still operational (e.g. emergency retraction).		
Dependency:	Refer to: r2043 Refer to: F01910		

r2050[0...11]	CO: PROFIdrive PZD receive word / PZD rcv word		
	Access level: 3	Calculated: -	Data type: Integer16
	Can be changed: -	Scaling: 4000H	Dyn. index: -
	Unit group: -	Unit selection: -	Func. diagram: 2440, 2468, 9360
	Min	Max	Factory setting
	-	-	-
Description:	Connector output to interconnect PZD (setpoints) with word format received from the fieldbus controller.		
Index:	[0] = PZD 1 [1] = PZD 2 [2] = PZD 3 [3] = PZD 4 [4] = PZD 5 [5] = PZD 6 [6] = PZD 7 [7] = PZD 8 [8] = PZD 9 [9] = PZD 10 [10] = PZD 11 [11] = PZD 12		
Notice:	Where there is a multiple interconnection of a connector output, all the connector inputs must either have Integer or FloatingPoint data types. A BICO interconnection for a single PZD can only take place either on r2050 or r2060.		

p2051[0...16]	CI: PROFIdrive PZD send word / PZD send word		
G115D ASI	Access level: 3	Calculated: -	Data type: U32 / Integer16
	Can be changed: U, T	Scaling: 4000H	Dyn. index: -
	Unit group: -	Unit selection: -	Func. diagram: 2450, 2470, 9370
	Min	Max	Factory setting
	-	-	[0] 2089[0] [1...16] 0
Description:	Selects the PZD (actual values) with word format to be sent to the fieldbus controller.		

Index:

- [0] = PZD 1
- [1] = PZD 2
- [2] = PZD 3
- [3] = PZD 4
- [4] = PZD 5
- [5] = PZD 6
- [6] = PZD 7
- [7] = PZD 8
- [8] = PZD 9
- [9] = PZD 10
- [10] = PZD 11
- [11] = PZD 12
- [12] = PZD 13
- [13] = PZD 14
- [14] = PZD 15
- [15] = PZD 16
- [16] = PZD 17

Notice: The parameter may be protected as a result of p0922 or p2079 and cannot be changed.

p2051[0...16] CI: PROFIdrive PZD send word / PZD send word

G115D I/O	Access level: 3	Calculated: -	Data type: U32 / Integer16
	Can be changed: U, T	Scaling: 4000H	Dyn. index: -
	Unit group: -	Unit selection: -	Func. diagram: 2450, 2470, 9370
	Min	Max	Factory setting
	-	-	0

Description: Selects the PZD (actual values) with word format to be sent to the fieldbus controller.

Index:

- [0] = PZD 1
- [1] = PZD 2
- [2] = PZD 3
- [3] = PZD 4
- [4] = PZD 5
- [5] = PZD 6
- [6] = PZD 7
- [7] = PZD 8
- [8] = PZD 9
- [9] = PZD 10
- [10] = PZD 11
- [11] = PZD 12
- [12] = PZD 13
- [13] = PZD 14
- [14] = PZD 15
- [15] = PZD 16
- [16] = PZD 17

Notice: The parameter may be protected as a result of p0922 or p2079 and cannot be changed.

p2051[0...16] CI: PROFIdrive PZD send word / PZD send word

G115D PN	Access level: 3	Calculated: -	Data type: U32 / Integer16
	Can be changed: U, T	Scaling: 4000H	Dyn. index: -
	Unit group: -	Unit selection: -	Func. diagram: 2450, 2470, 9370
	Min	Max	Factory setting
	-	-	[0] 2089[0]
			[1] 63[0]
			[2] 2089[4]
			[3...16] 0

Description: Selects the PZD (actual values) with word format to be sent to the fieldbus controller.

2.2 List of parameters

Index:
 [0] = PZD 1
 [1] = PZD 2
 [2] = PZD 3
 [3] = PZD 4
 [4] = PZD 5
 [5] = PZD 6
 [6] = PZD 7
 [7] = PZD 8
 [8] = PZD 9
 [9] = PZD 10
 [10] = PZD 11
 [11] = PZD 12
 [12] = PZD 13
 [13] = PZD 14
 [14] = PZD 15
 [15] = PZD 16
 [16] = PZD 17

Notice: The parameter may be protected as a result of p0922 or p2079 and cannot be changed.

r2053[0...16] PROFdrive diagnostics send PZD word / Diag send word

Access level: 3	Calculated: -	Data type: Unsigned16
Can be changed: -	Scaling: -	Dyn. index: -
Unit group: -	Unit selection: -	Func. diagram: 2450, 2470, 9370
Min	Max	Factory setting
-	-	-

Description: Displays the PZD (actual values) with word format sent to the fieldbus controller.

Index:
 [0] = PZD 1
 [1] = PZD 2
 [2] = PZD 3
 [3] = PZD 4
 [4] = PZD 5
 [5] = PZD 6
 [6] = PZD 7
 [7] = PZD 8
 [8] = PZD 9
 [9] = PZD 10
 [10] = PZD 11
 [11] = PZD 12
 [12] = PZD 13
 [13] = PZD 14
 [14] = PZD 15
 [15] = PZD 16
 [16] = PZD 17

Bit field:	Bit	Signal name	1 signal	0 signal	FP
	00	Bit 0	ON	OFF	-
	01	Bit 1	ON	OFF	-
	02	Bit 2	ON	OFF	-
	03	Bit 3	ON	OFF	-
	04	Bit 4	ON	OFF	-
	05	Bit 5	ON	OFF	-
	06	Bit 6	ON	OFF	-
	07	Bit 7	ON	OFF	-
	08	Bit 8	ON	OFF	-
	09	Bit 9	ON	OFF	-
	10	Bit 10	ON	OFF	-
	11	Bit 11	ON	OFF	-
	12	Bit 12	ON	OFF	-
	13	Bit 13	ON	OFF	-
	14	Bit 14	ON	OFF	-
	15	Bit 15	ON	OFF	-

r2060[0...10]	CO: PROFIdrive PZD receive double word / PZD recv DW		
	Access level: 3	Calculated: -	Data type: Integer32
	Can be changed: -	Scaling: 4000H	Dyn. index: -
	Unit group: -	Unit selection: -	Func. diagram: 2440, 2468
	Min	Max	Factory setting
	-	-	-
Description:	Connector output to interconnect PZD (setpoints) with double word format received from the fieldbus controller.		
Index:	[0] = PZD 1 + 2 [1] = PZD 2 + 3 [2] = PZD 3 + 4 [3] = PZD 4 + 5 [4] = PZD 5 + 6 [5] = PZD 6 + 7 [6] = PZD 7 + 8 [7] = PZD 8 + 9 [8] = PZD 9 + 10 [9] = PZD 10 + 11 [10] = PZD 11 + 12		
Dependency:	Refer to: r2050		
Notice:	Where there is a multiple interconnection of a connector output, all the connector inputs must either have Integer or FloatingPoint data types. A BICO interconnection for a single PZD can only take place either on r2050 or r2060.		
p2061[0...15]	CI: PROFIdrive PZD send double word / PZD send DW		
	Access level: 3	Calculated: -	Data type: U32 / Integer32
	Can be changed: U, T	Scaling: 4000H	Dyn. index: -
	Unit group: -	Unit selection: -	Func. diagram: 2470
	Min	Max	Factory setting
	-	-	0
Description:	Selects the PZD (actual values) with double word format to be sent to the fieldbus controller.		
Index:	[0] = PZD 1 + 2 [1] = PZD 2 + 3 [2] = PZD 3 + 4 [3] = PZD 4 + 5 [4] = PZD 5 + 6 [5] = PZD 6 + 7 [6] = PZD 7 + 8 [7] = PZD 8 + 9 [8] = PZD 9 + 10 [9] = PZD 10 + 11 [10] = PZD 11 + 12 [11] = PZD 12 + 13 [12] = PZD 13 + 14 [13] = PZD 14 + 15 [14] = PZD 15 + 16 [15] = PZD 16 + 17		
Dependency:	Refer to: p2051		
Notice:	A BICO interconnection for a single PZD can only take place either on p2051 or p2061. The parameter may be protected as a result of p0922 or p2079 and cannot be changed.		
r2063[0...15]	PROFIdrive diagnostics PZD send double word / Diag send DW		
	Access level: 3	Calculated: -	Data type: Unsigned32
	Can be changed: -	Scaling: -	Dyn. index: -
	Unit group: -	Unit selection: -	Func. diagram: 2470
	Min	Max	Factory setting
	-	-	-
Description:	Displays the PZD (actual values) with double word format sent to the fieldbus controller.		

2 Parameters

2.2 List of parameters

Index:

- [0] = PZD 1 + 2
- [1] = PZD 2 + 3
- [2] = PZD 3 + 4
- [3] = PZD 4 + 5
- [4] = PZD 5 + 6
- [5] = PZD 6 + 7
- [6] = PZD 7 + 8
- [7] = PZD 8 + 9
- [8] = PZD 9 + 10
- [9] = PZD 10 + 11
- [10] = PZD 11 + 12
- [11] = PZD 12 + 13
- [12] = PZD 13 + 14
- [13] = PZD 14 + 15
- [14] = PZD 15 + 16
- [15] = PZD 16 + 17

Bit field:	Bit	Signal name	1 signal	0 signal	FP
	00	Bit 0	ON	OFF	-
	01	Bit 1	ON	OFF	-
	02	Bit 2	ON	OFF	-
	03	Bit 3	ON	OFF	-
	04	Bit 4	ON	OFF	-
	05	Bit 5	ON	OFF	-
	06	Bit 6	ON	OFF	-
	07	Bit 7	ON	OFF	-
	08	Bit 8	ON	OFF	-
	09	Bit 9	ON	OFF	-
	10	Bit 10	ON	OFF	-
	11	Bit 11	ON	OFF	-
	12	Bit 12	ON	OFF	-
	13	Bit 13	ON	OFF	-
	14	Bit 14	ON	OFF	-
	15	Bit 15	ON	OFF	-
	16	Bit 16	ON	OFF	-
	17	Bit 17	ON	OFF	-
	18	Bit 18	ON	OFF	-
	19	Bit 19	ON	OFF	-
	20	Bit 20	ON	OFF	-
	21	Bit 21	ON	OFF	-
	22	Bit 22	ON	OFF	-
	23	Bit 23	ON	OFF	-
	24	Bit 24	ON	OFF	-
	25	Bit 25	ON	OFF	-
	26	Bit 26	ON	OFF	-
	27	Bit 27	ON	OFF	-
	28	Bit 28	ON	OFF	-
	29	Bit 29	ON	OFF	-
	30	Bit 30	ON	OFF	-
	31	Bit 31	ON	OFF	-

Notice: A maximum of 4 indices of the "trace" function can be used.

r2067[0...1]	PZD maximum interconnected / PZDmaxIntercon		
Access level: 3	Calculated: -	Data type: Unsigned16	
Can be changed: -	Scaling: -	Dyn. index: -	
Unit group: -	Unit selection: -	Func. diagram: -	
Min	Max	Factory setting	
-	-	-	

Description: Display for the maximum interconnected PZD in the receive/send direction
 Index 0: receive (r2050, r2060)
 Index 1: send (p2051, p2061)

p2072	Response receive value after PZD failure / Resp aft PZD fail			
	Access level: 3	Calculated: -	Data type: Unsigned32	
	Can be changed: T	Scaling: -	Dyn. index: -	
	Unit group: -	Unit selection: -	Func. diagram: -	
	Min	Max	Factory setting	
	-	-	0000 bin	
Description:	Sets the response for the receive value (r2090) after PZD failure.			
Bit field:	Bit	Signal name	1 signal	0 signal
	00	Unconditionally open holding brake (p0855)	Freeze value	Zero the value
				FP
				-
p2079	PROFIdrive PZD telegram selection extended / PZD telegr ext			
G115D PN	Access level: 1	Calculated: -	Data type: Integer16	
	Can be changed: T	Scaling: -	Dyn. index: -	
	Unit group: -	Unit selection: -	Func. diagram: -	
	Min	Max	Factory setting	
	1	999	1	
Description:	Sets the send and receive telegram. Contrary to p0922, a telegram can be selected using p2079 and subsequently expanded.			
Value:	1: Standard telegram 1, PZD-2/2 3: Standard telegram 3, PZD-5/9 20: Standard telegram 20, PZD-2/6 350: SIEMENS telegram 350, PZD-4/4 352: SIEMENS telegram 352, PZD-6/6 353: SIEMENS telegram 353, PZD-2/2, PKW-4/4 354: SIEMENS telegram 354, PZD-6/6, PKW-4/4 999: Free telegram configuration with BICO			
Dependency:	Refer to: p0922			
Note:	For p0922 < 999 the following applies: p2079 has the same value and is inhibited. All of the interconnections and extensions contained in the telegram are inhibited. For p0922 = 999 the following applies: p2079 can be freely set. If p2079 is also set to 999, then all of the interconnections can be set. For p0922 = 999 and p2079 < 999 the following applies: The interconnections contained in the telegram are inhibited. However, the telegram can be extended.			
p2080[0...15]	BI: Binector-connector converter status word 1 / Bin/con ZSW1			
G115D ASI	Access level: 3	Calculated: -	Data type: U32 / Binary	
	Can be changed: U, T	Scaling: -	Dyn. index: -	
	Unit group: -	Unit selection: -	Func. diagram: 2472	
	Min	Max	Factory setting	
	-	-	[0] 53.13 [1] 899.11 [2] 722.0 [3] 722.1 [4...15] 0	
Description:	Selects bits to be sent to the PROFIdrive controller. The individual bits are combined to form status word 1.			

Index:
 [0] = Bit 0
 [1] = Bit 1
 [2] = Bit 2
 [3] = Bit 3
 [4] = Bit 4
 [5] = Bit 5
 [6] = Bit 6
 [7] = Bit 7
 [8] = Bit 8
 [9] = Bit 9
 [10] = Bit 10
 [11] = Bit 11
 [12] = Bit 12
 [13] = Bit 13
 [14] = Bit 14
 [15] = Bit 15

Dependency: Refer to: p2088, r2089

Notice: The parameter may be protected as a result of p0922 or p2079 and cannot be changed.

p2080[0...15] Bl: Binector-connector converter status word 1 / Bin/con ZSW1

G115D I/O	Access level: 3	Calculated: -	Data type: U32 / Binary
	Can be changed: U, T	Scaling: -	Dyn. index: -
	Unit group: -	Unit selection: -	Func. diagram: 2472
	Min	Max	Factory setting
	-	-	0

Description: Selects bits to be sent to the PROFIdrive controller.
 The individual bits are combined to form status word 1.

Index:
 [0] = Bit 0
 [1] = Bit 1
 [2] = Bit 2
 [3] = Bit 3
 [4] = Bit 4
 [5] = Bit 5
 [6] = Bit 6
 [7] = Bit 7
 [8] = Bit 8
 [9] = Bit 9
 [10] = Bit 10
 [11] = Bit 11
 [12] = Bit 12
 [13] = Bit 13
 [14] = Bit 14
 [15] = Bit 15

Dependency: Refer to: p2088, r2089

Notice: The parameter may be protected as a result of p0922 or p2079 and cannot be changed.

p2080[0...15]	BI: Binector-connector converter status word 1 / Bin/con ZSW1		
G115D PN	Access level: 3	Calculated: -	Data type: U32 / Binary
	Can be changed: U, T	Scaling: -	Dyn. index: -
	Unit group: -	Unit selection: -	Func. diagram: 2472
	Min	Max	Factory setting
	-	-	[0] 899.0
			[1] 899.1
			[2] 899.2
			[3] 2139.3
			[4] 899.4
			[5] 899.5
			[6] 899.6
			[7] 2139.7
			[8] 2197.7
			[9] 899.9
			[10] 2199.1
			[11] 1407.7
			[12] 899.12
			[13] 2135.14
			[14] 2197.3
			[15] 2135.15

Description: Selects bits to be sent to the PROFIdrive controller.
The individual bits are combined to form status word 1.

Index:

- [0] = Bit 0
- [1] = Bit 1
- [2] = Bit 2
- [3] = Bit 3
- [4] = Bit 4
- [5] = Bit 5
- [6] = Bit 6
- [7] = Bit 7
- [8] = Bit 8
- [9] = Bit 9
- [10] = Bit 10
- [11] = Bit 11
- [12] = Bit 12
- [13] = Bit 13
- [14] = Bit 14
- [15] = Bit 15

Dependency: Refer to: p2088, r2089

Notice: The parameter may be protected as a result of p0922 or p2079 and cannot be changed.

p2081[0...15]	BI: Binector-connector converter status word 2 / Bin/con ZSW2		
	Access level: 3	Calculated: -	Data type: U32 / Binary
	Can be changed: U, T	Scaling: -	Dyn. index: -
	Unit group: -	Unit selection: -	Func. diagram: 2472
	Min	Max	Factory setting
	-	-	0

Description: Selects bits to be sent to the PROFIdrive controller.
The individual bits are combined to form status word 2.

2 Parameters

2.2 List of parameters

Index:
[0] = Bit 0
[1] = Bit 1
[2] = Bit 2
[3] = Bit 3
[4] = Bit 4
[5] = Bit 5
[6] = Bit 6
[7] = Bit 7
[8] = Bit 8
[9] = Bit 9
[10] = Bit 10
[11] = Bit 11
[12] = Bit 12
[13] = Bit 13
[14] = Bit 14
[15] = Bit 15

Dependency: Refer to: p2088, r2089

Notice: The parameter may be protected as a result of p0922 or p2079 and cannot be changed.

p2082[0...15]	BI: Binector-connector converter status word 3 / Bin/con ZSW3		
Access level: 3	Calculated: -	Data type: U32 / Binary	
Can be changed: U, T	Scaling: -	Dyn. index: -	
Unit group: -	Unit selection: -	Func. diagram: 2472	
Min	Max	Factory setting	
-	-	0	

Description: Selects bits to be sent to the PROFIdrive controller.
The individual bits are combined to form free status word 3.

Index:
[0] = Bit 0
[1] = Bit 1
[2] = Bit 2
[3] = Bit 3
[4] = Bit 4
[5] = Bit 5
[6] = Bit 6
[7] = Bit 7
[8] = Bit 8
[9] = Bit 9
[10] = Bit 10
[11] = Bit 11
[12] = Bit 12
[13] = Bit 13
[14] = Bit 14
[15] = Bit 15

Dependency: Refer to: p2088, r2089

Notice: The parameter may be protected as a result of p0922 or p2079 and cannot be changed.

p2083[0...15]	BI: Binector-connector converter status word 4 / Bin/con ZSW4		
Access level: 3	Calculated: -	Data type: U32 / Binary	
Can be changed: U, T	Scaling: -	Dyn. index: -	
Unit group: -	Unit selection: -	Func. diagram: 2472	
Min	Max	Factory setting	
-	-	0	

Description: Selects bits to be sent to the PROFIdrive controller.
The individual bits are combined to form free status word 4.

Index:	[0] = Bit 0 [1] = Bit 1 [2] = Bit 2 [3] = Bit 3 [4] = Bit 4 [5] = Bit 5 [6] = Bit 6 [7] = Bit 7 [8] = Bit 8 [9] = Bit 9 [10] = Bit 10 [11] = Bit 11 [12] = Bit 12 [13] = Bit 13 [14] = Bit 14 [15] = Bit 15
Dependency:	Refer to: p2088, r2089

p2084[0...15]	BI: Binector-connector converter status word 5 / Bin/con ZSW5		
G115D I/O	Access level: 3	Calculated: -	Data type: U32 / Binary
G115D ASI	Can be changed: U, T	Scaling: -	Dyn. index: -
	Unit group: -	Unit selection: -	Func. diagram: 2472
	Min	Max	Factory setting
	-	-	0

Description: Selects bits to be sent to the PROFIdrive controller.
The individual bits are combined to form free status word 5.

Index:	[0] = Bit 0 [1] = Bit 1 [2] = Bit 2 [3] = Bit 3 [4] = Bit 4 [5] = Bit 5 [6] = Bit 6 [7] = Bit 7 [8] = Bit 8 [9] = Bit 9 [10] = Bit 10 [11] = Bit 11 [12] = Bit 12 [13] = Bit 13 [14] = Bit 14 [15] = Bit 15
---------------	----------------------------------------------------------------------------------------------------------------------------------------------------------------------------------------------------------------------------------------------------------

Dependency: Refer to: p2088, r2089

p2084[0...15]	BI: Binector-connector converter status word 5 / Bin/con ZSW5		
G115D PN	Access level: 3	Calculated: -	Data type: U32 / Binary
	Can be changed: U, T	Scaling: -	Dyn. index: -
	Unit group: -	Unit selection: -	Func. diagram: 2472 2458
	Min	Max	Factory setting
	-	-	[0] 722.0
			[1] 722.1
			[2] 722.2
			[3] 722.3
			[4] 722.24
			[5] 722.25
			[6] 0
			[7] 0
			[8] 8559.12
			[9] 8559.2
			[10] 8559.3
			[11] 8559.4
			[12] 8559.5
			[13] 8559.6
			[14] 8559.7
			[15] 0
Description:	Selects bits to be sent to the PROFIdrive controller. The individual bits are combined to form free status word 5.		
Index:	[0] = Bit 0 [1] = Bit 1 [2] = Bit 2 [3] = Bit 3 [4] = Bit 4 [5] = Bit 5 [6] = Bit 6 [7] = Bit 7 [8] = Bit 8 [9] = Bit 9 [10] = Bit 10 [11] = Bit 11 [12] = Bit 12 [13] = Bit 13 [14] = Bit 14 [15] = Bit 15		
Dependency:	Refer to: p2088, r2089		

p2088[0...4]	Invert binector-connector converter status word / Bin/con ZSW inv		
G115D I/O	Access level: 3	Calculated: -	Data type: Unsigned16
G115D ASI	Can be changed: U, T	Scaling: -	Dyn. index: -
	Unit group: -	Unit selection: -	Func. diagram: 2472
	Min	Max	Factory setting
	-	-	0000 0000 0000 0000 bin
Description:	Setting to invert the individual binector inputs of the binector-connector converter.		
Index:	[0] = Status word 1 [1] = Status word 2 [2] = Free status word 3 [3] = Free status word 4 [4] = Free status word 5		

Bit field:	Bit	Signal name	1 signal	0 signal	FP
	00	Bit 0	Inverted	Not inverted	-
	01	Bit 1	Inverted	Not inverted	-
	02	Bit 2	Inverted	Not inverted	-
	03	Bit 3	Inverted	Not inverted	-
	04	Bit 4	Inverted	Not inverted	-
	05	Bit 5	Inverted	Not inverted	-
	06	Bit 6	Inverted	Not inverted	-
	07	Bit 7	Inverted	Not inverted	-
	08	Bit 8	Inverted	Not inverted	-
	09	Bit 9	Inverted	Not inverted	-
	10	Bit 10	Inverted	Not inverted	-
	11	Bit 11	Inverted	Not inverted	-
	12	Bit 12	Inverted	Not inverted	-
	13	Bit 13	Inverted	Not inverted	-
	14	Bit 14	Inverted	Not inverted	-
	15	Bit 15	Inverted	Not inverted	-

Dependency: Refer to: p2080, p2081, p2082, p2083, r2089

p2088[0...4] Invert binector-connector converter status word / Bin/con ZSW inv

G115D PN	Access level: 3	Calculated: -	Data type: Unsigned16
	Can be changed: U, T	Scaling: -	Dyn. index: -
	Unit group: -	Unit selection: -	Func. diagram: 2472
	Min	Max	Factory setting
	-	-	[0] 1010 1000 0000 0000 bin [1...4] 0000 0000 0000 0000 bin

Description: Setting to invert the individual binector inputs of the binector-connector converter.

Index:
 [0] = Status word 1
 [1] = Status word 2
 [2] = Free status word 3
 [3] = Free status word 4
 [4] = Free status word 5

Bit field:	Bit	Signal name	1 signal	0 signal	FP
	00	Bit 0	Inverted	Not inverted	-
	01	Bit 1	Inverted	Not inverted	-
	02	Bit 2	Inverted	Not inverted	-
	03	Bit 3	Inverted	Not inverted	-
	04	Bit 4	Inverted	Not inverted	-
	05	Bit 5	Inverted	Not inverted	-
	06	Bit 6	Inverted	Not inverted	-
	07	Bit 7	Inverted	Not inverted	-
	08	Bit 8	Inverted	Not inverted	-
	09	Bit 9	Inverted	Not inverted	-
	10	Bit 10	Inverted	Not inverted	-
	11	Bit 11	Inverted	Not inverted	-
	12	Bit 12	Inverted	Not inverted	-
	13	Bit 13	Inverted	Not inverted	-
	14	Bit 14	Inverted	Not inverted	-
	15	Bit 15	Inverted	Not inverted	-

Dependency: Refer to: p2080, p2081, p2082, p2083, r2089

r2089[0...4] CO: Send binector-connector converter status word / Bin/con ZSW send

Access level: 3	Calculated: -	Data type: Unsigned16
Can be changed: -	Scaling: -	Dyn. index: -
Unit group: -	Unit selection: -	Func. diagram: 2472
Min	Max	Factory setting
-	-	-

Description: Connector output to interconnect the status words to a PZD send word.

2 Parameters

2.2 List of parameters

Index:
 [0] = Status word 1
 [1] = Status word 2
 [2] = Free status word 3
 [3] = Free status word 4
 [4] = Free status word 5

Bit field:	Bit	Signal name	1 signal	0 signal	FP
	00	Bit 0	ON	OFF	-
	01	Bit 1	ON	OFF	-
	02	Bit 2	ON	OFF	-
	03	Bit 3	ON	OFF	-
	04	Bit 4	ON	OFF	-
	05	Bit 5	ON	OFF	-
	06	Bit 6	ON	OFF	-
	07	Bit 7	ON	OFF	-
	08	Bit 8	ON	OFF	-
	09	Bit 9	ON	OFF	-
	10	Bit 10	ON	OFF	-
	11	Bit 11	ON	OFF	-
	12	Bit 12	ON	OFF	-
	13	Bit 13	ON	OFF	-
	14	Bit 14	ON	OFF	-
	15	Bit 15	ON	OFF	-

Dependency: Refer to: p2051, p2080, p2081, p2082, p2083
Note: r2089 together with p2080 to p2084 forms five binector-connector converters.

r2090.0...15	BO: PROFIdrive PZD1 receive bit-serial / PZD1 recv bitw		
Access level: 3	Calculated: -	Data type: Unsigned16	
Can be changed: -	Scaling: -	Dyn. index: -	
Unit group: -	Unit selection: -	Func. diagram: 2468, 9360	
Min	Max	Factory setting	
-	-	-	

Description: Binector output for bit-serial interconnection of PZD1 (normally control word 1) received from the PROFIdrive controller.

Bit field:	Bit	Signal name	1 signal	0 signal	FP
	00	Bit 0	ON	OFF	-
	01	Bit 1	ON	OFF	-
	02	Bit 2	ON	OFF	-
	03	Bit 3	ON	OFF	-
	04	Bit 4	ON	OFF	-
	05	Bit 5	ON	OFF	-
	06	Bit 6	ON	OFF	-
	07	Bit 7	ON	OFF	-
	08	Bit 8	ON	OFF	-
	09	Bit 9	ON	OFF	-
	10	Bit 10	ON	OFF	-
	11	Bit 11	ON	OFF	-
	12	Bit 12	ON	OFF	-
	13	Bit 13	ON	OFF	-
	14	Bit 14	ON	OFF	-
	15	Bit 15	ON	OFF	-

r2091.0...15	BO: PROFIdrive PZD2 receive bit-serial / PZD2 recv bitw		
Access level: 3	Calculated: -	Data type: Unsigned16	
Can be changed: -	Scaling: -	Dyn. index: -	
Unit group: -	Unit selection: -	Func. diagram: 2468	
Min	Max	Factory setting	
-	-	-	

Description: Binector output for bit-serial interconnection of PZD2 received from the PROFIdrive controller.

Bit field:	Bit	Signal name	1 signal	0 signal	FP
	00	Bit 0	ON	OFF	-
	01	Bit 1	ON	OFF	-
	02	Bit 2	ON	OFF	-
	03	Bit 3	ON	OFF	-
	04	Bit 4	ON	OFF	-
	05	Bit 5	ON	OFF	-
	06	Bit 6	ON	OFF	-
	07	Bit 7	ON	OFF	-
	08	Bit 8	ON	OFF	-
	09	Bit 9	ON	OFF	-
	10	Bit 10	ON	OFF	-
	11	Bit 11	ON	OFF	-
	12	Bit 12	ON	OFF	-
	13	Bit 13	ON	OFF	-
	14	Bit 14	ON	OFF	-
	15	Bit 15	ON	OFF	-

r2092.0...15 BO: PROFIdrive PZD3 receive bit-serial / PZD3 recv bitw

Access level: 3	Calculated: -	Data type: Unsigned16
Can be changed: -	Scaling: -	Dyn. index: -
Unit group: -	Unit selection: -	Func. diagram: 2468
Min	Max	Factory setting
-	-	-

Description: Binector output for bit-serial interconnection of PZD3 received from the PROFIdrive controller.

Bit field:	Bit	Signal name	1 signal	0 signal	FP
	00	Bit 0	ON	OFF	-
	01	Bit 1	ON	OFF	-
	02	Bit 2	ON	OFF	-
	03	Bit 3	ON	OFF	-
	04	Bit 4	ON	OFF	-
	05	Bit 5	ON	OFF	-
	06	Bit 6	ON	OFF	-
	07	Bit 7	ON	OFF	-
	08	Bit 8	ON	OFF	-
	09	Bit 9	ON	OFF	-
	10	Bit 10	ON	OFF	-
	11	Bit 11	ON	OFF	-
	12	Bit 12	ON	OFF	-
	13	Bit 13	ON	OFF	-
	14	Bit 14	ON	OFF	-
	15	Bit 15	ON	OFF	-

r2093.0...15 BO: PROFIdrive PZD4 receive bit-serial / PZD4 recv bitw

Access level: 3	Calculated: -	Data type: Unsigned16
Can be changed: -	Scaling: -	Dyn. index: -
Unit group: -	Unit selection: -	Func. diagram: 2468
Min	Max	Factory setting
-	-	-

Description: Binector output for bit-serial interconnection of PZD4 (normally control word 2) received from the PROFIdrive controller.

Bit field:	Bit	Signal name	1 signal	0 signal	FP
	00	Bit 0	ON	OFF	-
	01	Bit 1	ON	OFF	-
	02	Bit 2	ON	OFF	-
	03	Bit 3	ON	OFF	-
	04	Bit 4	ON	OFF	-
	05	Bit 5	ON	OFF	-

2 Parameters

2.2 List of parameters

06	Bit 6	ON	OFF	-
07	Bit 7	ON	OFF	-
08	Bit 8	ON	OFF	-
09	Bit 9	ON	OFF	-
10	Bit 10	ON	OFF	-
11	Bit 11	ON	OFF	-
12	Bit 12	ON	OFF	-
13	Bit 13	ON	OFF	-
14	Bit 14	ON	OFF	-
15	Bit 15	ON	OFF	-

r2094.0...15 **BO: Connector-binector converter binector output / Con/bin outp**

Access level: 3	Calculated: -	Data type: Unsigned16
Can be changed: -	Scaling: -	Dyn. index: -
Unit group: -	Unit selection: -	Func. diagram: 2468, 9360
Min	Max	Factory setting
-	-	-

Description: Binector output for bit-serial onward interconnection of a PZD word received from the PROFIdrive controller. The PZD is selected via p2099[0].

Bit field:	Bit	Signal name	1 signal	0 signal	FP
	00	Bit 0	ON	OFF	-
	01	Bit 1	ON	OFF	-
	02	Bit 2	ON	OFF	-
	03	Bit 3	ON	OFF	-
	04	Bit 4	ON	OFF	-
	05	Bit 5	ON	OFF	-
	06	Bit 6	ON	OFF	-
	07	Bit 7	ON	OFF	-
	08	Bit 8	ON	OFF	-
	09	Bit 9	ON	OFF	-
	10	Bit 10	ON	OFF	-
	11	Bit 11	ON	OFF	-
	12	Bit 12	ON	OFF	-
	13	Bit 13	ON	OFF	-
	14	Bit 14	ON	OFF	-
	15	Bit 15	ON	OFF	-

Dependency: Refer to: p2099

r2095.0...15 **BO: Connector-binector converter binector output / Con/bin outp**

Access level: 3	Calculated: -	Data type: Unsigned16
Can be changed: -	Scaling: -	Dyn. index: -
Unit group: -	Unit selection: -	Func. diagram: 2468, 9360
Min	Max	Factory setting
-	-	-

Description: Binector output for bit-serial interconnection of a PZD word received from the PROFIdrive controller. The PZD is selected via p2099[1].

Bit field:	Bit	Signal name	1 signal	0 signal	FP
	00	Bit 0	ON	OFF	-
	01	Bit 1	ON	OFF	-
	02	Bit 2	ON	OFF	-
	03	Bit 3	ON	OFF	-
	04	Bit 4	ON	OFF	-
	05	Bit 5	ON	OFF	-

06	Bit 6	ON	OFF	-
07	Bit 7	ON	OFF	-
08	Bit 8	ON	OFF	-
09	Bit 9	ON	OFF	-
10	Bit 10	ON	OFF	-
11	Bit 11	ON	OFF	-
12	Bit 12	ON	OFF	-
13	Bit 13	ON	OFF	-
14	Bit 14	ON	OFF	-
15	Bit 15	ON	OFF	-

Dependency: Refer to: p2099

p2098[0...1] Inverter connector-binector converter binector output / Con/bin outp inv

Access level: 3	Calculated: -	Data type: Unsigned16
Can be changed: U, T	Scaling: -	Dyn. index: -
Unit group: -	Unit selection: -	Func. diagram: 2468, 9360
Min	Max	Factory setting
-	-	0000 0000 0000 0000 bin

Description: Setting to invert the individual binector outputs of the connector-binector converter.
Using p2098[0], the signals of connector input p2099[0] are influenced.
Using p2098[1], the signals of connector input p2099[1] are influenced.

Bit field:	Bit	Signal name	1 signal	0 signal	FP
	00	Bit 0	Inverted	Not inverted	-
	01	Bit 1	Inverted	Not inverted	-
	02	Bit 2	Inverted	Not inverted	-
	03	Bit 3	Inverted	Not inverted	-
	04	Bit 4	Inverted	Not inverted	-
	05	Bit 5	Inverted	Not inverted	-
	06	Bit 6	Inverted	Not inverted	-
	07	Bit 7	Inverted	Not inverted	-
	08	Bit 8	Inverted	Not inverted	-
	09	Bit 9	Inverted	Not inverted	-
	10	Bit 10	Inverted	Not inverted	-
	11	Bit 11	Inverted	Not inverted	-
	12	Bit 12	Inverted	Not inverted	-
	13	Bit 13	Inverted	Not inverted	-
	14	Bit 14	Inverted	Not inverted	-
	15	Bit 15	Inverted	Not inverted	-

Dependency: Refer to: r2094, r2095, p2099

p2099[0...1] CI: Connector-binector converter signal source / Con/bin s_s

G115D I/O	Access level: 3	Calculated: -	Data type: U32 / Integer16
G115D ASI	Can be changed: U, T	Scaling: -	Dyn. index: -
	Unit group: -	Unit selection: -	Func. diagram: 2468, 9360
	Min	Max	Factory setting
	-	-	0

Description: Sets the signal source for the connector-binector converter.
A PZD receive word can be selected as signal source. The signals are available to be serially passed-on (interconnection).

Dependency: Refer to: r2094, r2095

Note: From the signal source set via the connector input, the corresponding lower 16 bits are converted. p2099[0...1] together with r2094.0...15 and r2095.0...15 forms two connector-binector converters:
Connector input p2099[0] to binector output in r2094.0...15
Connector input p2099[1] to binector output in r2095.0...15

p2099[0...1]	CI: Connector-binector converter signal source / Con/bin s_s		
G115D PN	Access level: 3	Calculated: -	Data type: U32 / Integer16
	Can be changed: U, T	Scaling: -	Dyn. index: -
	Unit group: -	Unit selection: -	Func. diagram: 2468, 9360
	Min	Max	Factory setting
	-	-	[0] 2050[2] [1] 0
Description:	Sets the signal source for the connector-binector converter. A PZD receive word can be selected as signal source. The signals are available to be serially passed-on (interconnection).		
Dependency:	Refer to: r2094, r2095		
Note:	From the signal source set via the connector input, the corresponding lower 16 bits are converted. p2099[0...1] together with r2094.0...15 and r2095.0...15 forms two connector-binector converters: Connector input p2099[0] to binector output in r2094.0...15 Connector input p2099[1] to binector output in r2095.0...15		
p2100[0...19]	Change fault response fault number / Chng resp F_no		
	Access level: 3	Calculated: -	Data type: Unsigned16
	Can be changed: U, T	Scaling: -	Dyn. index: -
	Unit group: -	Unit selection: -	Func. diagram: 8050, 8075
	Min	Max	Factory setting
	0	65535	0
Description:	Selects the faults for which the fault response should be changed		
Dependency:	The fault is selected and the required response is set under the same index. Refer to: p2101		
Note:	Re-parameterization is also possible if a fault is present. The change only becomes effective after the fault has been resolved.		
p2101[0...19]	Change fault response response / Chng resp resp		
	Access level: 3	Calculated: -	Data type: Integer16
	Can be changed: U, T	Scaling: -	Dyn. index: -
	Unit group: -	Unit selection: -	Func. diagram: 8050, 8075
	Min	Max	Factory setting
	0	6	0
Description:	Sets the fault response for the selected fault.		
Value:	0: NONE 1: OFF1 2: OFF2 3: OFF3 5: STOP2 6: Internal armature short-circuit / DC braking		
Dependency:	The fault is selected and the required response is set under the same index. Refer to: p2100		
Notice:	For the following cases, it is not possible to re-parameterize the fault response to a fault: - fault number does not exist (exception value = 0). - Message type is not "fault" (F). - fault response is not permissible for the set fault number.		

Note: Re-parameterization is also possible if a fault is present. The change only becomes effective after the fault has been resolved.
 The fault response can only be changed for faults with the appropriate identification.
 Example:
 F12345 and fault response = NONE (OFF1, OFF2)
 --> The fault response NONE can be changed to OFF1 or OFF2.
 For value = 1 (OFF1):
 Braking along the ramp-function generator down ramp followed by a pulse inhibit.
 For value = 2 (OFF2):
 Internal/external pulse inhibit.
 For value = 3 (OFF3):
 Braking along the OFF3 down ramp followed by a pulse inhibit.
 For value = 5 (STOP2):
 n_set = 0
 For value = 6 (armature short-circuit, internal/DC braking):
 This value can only be set for all drive data sets when p1231 = 4.
 a) DC braking is not possible for synchronous motors.
 b) DC braking is possible for induction motors.

p2103[0...n]		BI: 1st acknowledge faults / 1st acknowledge	
G115D ASI	Access level: 3 Can be changed: U, T Unit group: -	Calculated: - Scaling: - Unit selection: -	Data type: U32 / Binary Dyn. index: CDS, p0170 Func. diagram: 2441, 2442, 2443, 2447, 2475, 2546, 9220, 9677, 9678 Factory setting 0
Description:	Sets the first signal source to acknowledge faults.		
Notice:	The parameter may be protected as a result of p0922 or p2079 and cannot be changed.		
Note:	A fault acknowledgment is triggered with a 0/1 signal.		
p2103[0...n]		BI: 1st acknowledge faults / 1st acknowledge	
G115D I/O	Access level: 3 Can be changed: U, T Unit group: -	Calculated: - Scaling: - Unit selection: -	Data type: U32 / Binary Dyn. index: CDS, p0170 Func. diagram: 2441, 2442, 2443, 2447, 2475, 2546, 9220, 9677, 9678 Factory setting 722.2
Description:	Sets the first signal source to acknowledge faults.		
Notice:	The parameter may be protected as a result of p0922 or p2079 and cannot be changed.		
Note:	A fault acknowledgment is triggered with a 0/1 signal.		
p2103[0...n]		BI: 1st acknowledge faults / 1st acknowledge	
G115D PN	Access level: 3 Can be changed: U, T Unit group: -	Calculated: - Scaling: - Unit selection: -	Data type: U32 / Binary Dyn. index: CDS, p0170 Func. diagram: 2441, 2442, 2443, 2447, 2475, 2546, 9220, 9677, 9678 Factory setting [0] 2090.7 [1] 722.2 [2] 2090.7 [3] 2090.7
Description:	Sets the first signal source to acknowledge faults.		
Notice:	The parameter may be protected as a result of p0922 or p2079 and cannot be changed.		
Note:	A fault acknowledgment is triggered with a 0/1 signal.		

p2104[0...n]	BI: 2nd acknowledge faults / 2nd acknowledge		
G115D ASI	Access level: 3	Calculated: -	Data type: U32 / Binary
	Can be changed: U, T	Scaling: -	Dyn. index: CDS, p0170
	Unit group: -	Unit selection: -	Func. diagram: 2546, 8060
	Min	Max	Factory setting
	-	-	[0] 2090.7
			[1] 0
			[2] 0
			[3] 0
Description:	Sets the second signal source to acknowledge faults.		
Note:	A fault acknowledgment is triggered with a 0/1 signal.		
p2104[0...n]	BI: 2nd acknowledge faults / 2nd acknowledge		
G115D I/O	Access level: 3	Calculated: -	Data type: U32 / Binary
	Can be changed: U, T	Scaling: -	Dyn. index: CDS, p0170
	Unit group: -	Unit selection: -	Func. diagram: 2546, 8060
	Min	Max	Factory setting
	-	-	0
Description:	Sets the second signal source to acknowledge faults.		
Note:	A fault acknowledgment is triggered with a 0/1 signal.		
p2104[0...n]	BI: 2nd acknowledge faults / 2nd acknowledge		
G115D PN	Access level: 3	Calculated: -	Data type: U32 / Binary
	Can be changed: U, T	Scaling: -	Dyn. index: CDS, p0170
	Unit group: -	Unit selection: -	Func. diagram: 2546, 8060
	Min	Max	Factory setting
	-	-	[0] 722.2
			[1] 0
			[2] 0
			[3] 0
Description:	Sets the second signal source to acknowledge faults.		
Note:	A fault acknowledgment is triggered with a 0/1 signal.		
p2105[0...n]	BI: 3rd acknowledge faults / 3rd acknowledge		
	Access level: 3	Calculated: -	Data type: U32 / Binary
	Can be changed: U, T	Scaling: -	Dyn. index: CDS, p0170
	Unit group: -	Unit selection: -	Func. diagram: 2546, 8060
	Min	Max	Factory setting
	-	-	0
Description:	Sets the third signal source to acknowledge faults.		
Note:	A fault acknowledgment is triggered with a 0/1 signal.		
p2106[0...n]	BI: External fault 1 / External fault 1		
	Access level: 3	Calculated: -	Data type: U32 / Binary
	Can be changed: U, T	Scaling: -	Dyn. index: CDS, p0170
	Unit group: -	Unit selection: -	Func. diagram: 2546
	Min	Max	Factory setting
	-	-	1
Description:	Sets the signal source for external fault 1.		
Dependency:	Refer to: F07860		
Note:	An external fault is triggered with a 1/0 signal.		

p2107[0...n]	Bl: External fault 2 / External fault 2		
	Access level: 3	Calculated: -	Data type: U32 / Binary
	Can be changed: U, T	Scaling: -	Dyn. index: CDS, p0170
	Unit group: -	Unit selection: -	Func. diagram: 2546
	Min	Max	Factory setting
	-	-	1
Description:	Sets the signal source for external fault 2.		
Dependency:	Refer to: F07861		
Note:	An external fault is triggered with a 1/0 signal.		
p2108[0...n]	Bl: External fault 3 / External fault 3		
	Access level: 3	Calculated: -	Data type: U32 / Binary
	Can be changed: U, T	Scaling: -	Dyn. index: CDS, p0170
	Unit group: -	Unit selection: -	Func. diagram: 2546
	Min	Max	Factory setting
	-	-	1
Description:	Sets the signal source for external fault 3. External fault 3 is initiated by the following AND logic operation:		
	- Bl: p2108 negated		
	- Bl: p3111		
	- Bl: p3112 negated		
Dependency:	Refer to: p3110, p3111, p3112		
	Refer to: F07862		
Note:	An external fault is triggered with a 1/0 signal.		
r2109[0...63]	Fault time removed in milliseconds / t_flt resolved ms		
	Access level: 3	Calculated: -	Data type: Unsigned32
	Can be changed: -	Scaling: -	Dyn. index: -
	Unit group: -	Unit selection: -	Func. diagram: 8050, 8060
	Min	Max	Factory setting
	- [ms]	- [ms]	- [ms]
Description:	Displays the system runtime in milliseconds when the fault was removed.		
Dependency:	Refer to: r0945, r0947, r0948, r0949, r2130, r2133, r2136		
Notice:	The time comprises r2136 (days) and r2109 (milliseconds).		
Note:	The buffer parameters are cyclically updated in the background (refer to status signal in r2139). The structure of the fault buffer and the assignment of the indices is shown in r0945.		
r2110[0...63]	Alarm number / Alarm number		
	Access level: 2	Calculated: -	Data type: Unsigned16
	Can be changed: -	Scaling: -	Dyn. index: -
	Unit group: -	Unit selection: -	Func. diagram: 8065
	Min	Max	Factory setting
	-	-	-
Description:	This parameter is identical to r2122.		
p2111	Alarm counter / Alarm counter		
	Access level: 3	Calculated: -	Data type: Unsigned16
	Can be changed: U, T	Scaling: -	Dyn. index: -
	Unit group: -	Unit selection: -	Func. diagram: 8050, 8065
	Min	Max	Factory setting
	0	65535	0
Description:	Number of alarms that have occurred after the last reset.		

2 Parameters

2.2 List of parameters

Dependency: When p2111 is set to 0, the following is initiated:
- all of the alarms of the alarm buffer that have gone [0...7] are transferred into the alarm history [8...63].
- the alarm buffer [0...7] is deleted.

Refer to: r2110, r2122, r2123, r2124, r2125

Note: The parameter is reset to 0 at POWER ON.

p2112[0...n]	BI: External alarm 1 / External alarm 1		
Access level: 3	Calculated: -	Data type: U32 / Binary	
Can be changed: U, T	Scaling: -	Dyn. index: CDS, p0170	
Unit group: -	Unit selection: -	Func. diagram: 2546	
Min	Max	Factory setting	
-	-	1	

Description: Sets the signal source for external alarm 1.

Dependency: Refer to: A07850

Note: An external alarm is triggered with a 1/0 signal.

r2114[0...1]	System runtime total / Sys runtime tot		
Access level: 3	Calculated: -	Data type: Unsigned32	
Can be changed: -	Scaling: -	Dyn. index: -	
Unit group: -	Unit selection: -	Func. diagram: -	
Min	Max	Factory setting	
-	-	-	

Description: Displays the total system runtime for the drive unit.

The time comprises r2114[0] (milliseconds) and r2114[1] (days).

After r2114[0] has reached a value of 86.400.000 ms (24 hours) this value is reset and r2114[1] is incremented.

Index: [0] = Milliseconds
[1] = Days

Dependency: Refer to: r0948, r2109, r2123, r2125, r2130, r2136, r2145, r2146

Note: When the electronic power supply is switched out, the counter values are saved.

After the drive unit is switched on, the counter continues to run with the last value that was saved.

p2116[0...n]	BI: External alarm 2 / External alarm 2		
Access level: 3	Calculated: -	Data type: U32 / Binary	
Can be changed: U, T	Scaling: -	Dyn. index: CDS, p0170	
Unit group: -	Unit selection: -	Func. diagram: 2546	
Min	Max	Factory setting	
-	-	1	

Description: Sets the signal source for external alarm 2.

Dependency: Refer to: A07851

Note: An external alarm is triggered with a 1/0 signal.

p2117[0...n]	BI: External alarm 3 / External alarm 3		
Access level: 3	Calculated: -	Data type: U32 / Binary	
Can be changed: U, T	Scaling: -	Dyn. index: CDS, p0170	
Unit group: -	Unit selection: -	Func. diagram: 2546	
Min	Max	Factory setting	
-	-	1	

Description: Sets the signal source for external alarm 3.

Dependency: Refer to: A07852

Note: An external alarm is triggered with a 1/0 signal.

p2118[0...19]	Change message type message number / Chng type msg_no		
	Access level: 3	Calculated: -	Data type: Unsigned16
	Can be changed: U, T	Scaling: -	Dyn. index: -
	Unit group: -	Unit selection: -	Func. diagram: 8050, 8075
	Min	Max	Factory setting
	0	65535	0
Description:	Selects faults or alarms for which the message type should be changed.		
Dependency:	Selects the fault or alarm selection and sets the required type of message realized under the same index. Refer to: p2119		
Note:	Re-parameterization is also possible if a message is present. The change only becomes effective after the message has gone.		
p2119[0...19]	Change message type type / Change type type		
	Access level: 3	Calculated: -	Data type: Integer16
	Can be changed: U, T	Scaling: -	Dyn. index: -
	Unit group: -	Unit selection: -	Func. diagram: 8050, 8075
	Min	Max	Factory setting
	1	3	1
Description:	Sets the message type for the selected fault or alarm.		
Value:	1: Fault (F) 2: Alarm (A) 3: No message (N)		
Dependency:	Selects the fault or alarm selection and sets the required type of message realized under the same index. Refer to: p2118		
Note:	Re-parameterization is also possible if a message is present. The change only becomes effective after the message has gone. The message type can only be changed for messages with the appropriate identification (exception, value = 0). Example: F12345(A) --> Fault F12345 can be changed to alarm A12345. In this case, the message number that may be possibly entered in p2100[0...19] and p2126[0...19] is automatically removed.		
r2120	CO: Sum of fault and alarm buffer changes / Sum buffer changed		
	Access level: 4	Calculated: -	Data type: Unsigned16
	Can be changed: -	Scaling: -	Dyn. index: -
	Unit group: -	Unit selection: -	Func. diagram: 8065
	Min	Max	Factory setting
	-	-	-
Description:	Displays the sum of all of the fault and alarm buffer changes in the drive unit.		
Dependency:	Refer to: r0944, r2121		
r2121	CO: Counter alarm buffer changes / Alrm buff changed		
	Access level: 3	Calculated: -	Data type: Unsigned16
	Can be changed: -	Scaling: -	Dyn. index: -
	Unit group: -	Unit selection: -	Func. diagram: 8065
	Min	Max	Factory setting
	-	-	-
Description:	This counter is incremented every time the alarm buffer changes.		
Dependency:	Refer to: r2110, r2122, r2123, r2124, r2125		

r2122[0...63]	Alarm code / Alarm code		
	Access level: 2	Calculated: -	Data type: Unsigned16
	Can be changed: -	Scaling: -	Dyn. index: -
	Unit group: -	Unit selection: -	Func. diagram: 8050, 8065
	Min	Max	Factory setting
	-	-	-
Description:	Displays the number of alarms that have occurred.		
Dependency:	Refer to: r2110, r2123, r2124, r2125, r2134, r2145, r2146, r3121, r3123		
Notice:	The properties of the alarm buffer should be taken from the corresponding product documentation.		
Note:	The buffer parameters are cyclically updated in the background (refer to status signal in r2139). Alarm buffer structure (general principle): r2122[0], r2124[0], r2123[0], r2125[0] --> alarm 1 (the oldest) ... r2122[7], r2124[7], r2123[7], r2125[7] --> Alarm 8 (the latest) When the alarm buffer is full, the alarms that have gone are entered into the alarm history: r2122[8], r2124[8], r2123[8], r2125[8] --> Alarm 1 (the latest) ... r2122[63], r2124[63], r2123[63], r2125[63] --> alarm 56 (the oldest)		
r2123[0...63]	Alarm time received in milliseconds / t_alarm rcv ms		
	Access level: 3	Calculated: -	Data type: Unsigned32
	Can be changed: -	Scaling: -	Dyn. index: -
	Unit group: -	Unit selection: -	Func. diagram: 8050, 8065
	Min	Max	Factory setting
	- [ms]	- [ms]	- [ms]
Description:	Displays the system runtime in milliseconds when the alarm occurred.		
Dependency:	Refer to: r2110, r2122, r2124, r2125, r2134, r2145, r2146		
Notice:	The time comprises r2145 (days) and r2123 (milliseconds).		
Note:	The buffer parameters are cyclically updated in the background (refer to status signal in r2139). The structure of the alarm buffer and the assignment of the indices is shown in r2122.		
r2124[0...63]	Alarm value / Alarm value		
	Access level: 3	Calculated: -	Data type: Integer32
	Can be changed: -	Scaling: -	Dyn. index: -
	Unit group: -	Unit selection: -	Func. diagram: 8050, 8065
	Min	Max	Factory setting
	-	-	-
Description:	Displays additional information about the active alarm (as integer number).		
Dependency:	Refer to: r2110, r2122, r2123, r2125, r2134, r2145, r2146, r3121, r3123		
Note:	The buffer parameters are cyclically updated in the background (refer to status signal in r2139). The structure of the alarm buffer and the assignment of the indices is shown in r2122.		
r2125[0...63]	Alarm time removed in milliseconds / t_alarm res ms		
	Access level: 3	Calculated: -	Data type: Unsigned32
	Can be changed: -	Scaling: -	Dyn. index: -
	Unit group: -	Unit selection: -	Func. diagram: 8050, 8065
	Min	Max	Factory setting
	- [ms]	- [ms]	- [ms]
Description:	Displays the system runtime in milliseconds when the alarm was cleared.		
Dependency:	Refer to: r2110, r2122, r2123, r2124, r2134, r2145, r2146		
Notice:	The time comprises r2146 (days) and r2125 (milliseconds).		

Note: The buffer parameters are cyclically updated in the background (refer to status signal in r2139).
The structure of the alarm buffer and the assignment of the indices is shown in r2122.

p2126[0...19]	Change acknowledge mode fault number / Chng ackn F_no		
	Access level: 3	Calculated: -	Data type: Unsigned16
	Can be changed: U, T	Scaling: -	Dyn. index: -
	Unit group: -	Unit selection: -	Func. diagram: 8050, 8075
	Min	Max	Factory setting
	0	65535	0
Description:	Selects the faults for which the acknowledge mode is to be changed		
Dependency:	Selects the faults and sets the required acknowledge mode realized under the same index Refer to: p2127		
Note:	Re-parameterization is also possible if a fault is present. The change only becomes effective after the fault has been resolved.		

p2127[0...19]	Change acknowledge mode mode / Chng ackn mode		
	Access level: 3	Calculated: -	Data type: Integer16
	Can be changed: U, T	Scaling: -	Dyn. index: -
	Unit group: -	Unit selection: -	Func. diagram: 8050, 8075
	Min	Max	Factory setting
	1	2	1
Description:	Sets the acknowledge mode for selected fault.		
Value:	1: Acknowledgment only using POWER ON 2: Ack IMMEDIATELY after the fault cause has been removed		
Dependency:	Selects the faults and sets the required acknowledge mode realized under the same index Refer to: p2126		
Notice:	It is not possible to re-parameterize the acknowledge mode for a fault in the following cases: - fault number does not exist (exception value = 0). - Message type is not "fault" (F). - Acknowledge mode is not permissible for the set fault number.		
Note:	Re-parameterization is also possible if a fault is present. The change only becomes effective after the fault has been resolved. The acknowledge mode can only be changed for faults with the appropriate identification. Example: F12345 and acknowledge mode = IMMEDIATELY (POWER ON) --> The acknowledge mode can be changed from IMMEDIATELY to POWER ON.		

p2128[0...15]	Faults/alarms trigger selection / F/A trigger sel		
	Access level: 3	Calculated: -	Data type: Unsigned16
	Can be changed: U, T	Scaling: -	Dyn. index: -
	Unit group: -	Unit selection: -	Func. diagram: 8050, 8070
	Min	Max	Factory setting
	0	65535	0
Description:	Sets the faults/alarms for which a trigger signal should be generated in r2129.0...15.		
Dependency:	If the fault/alarm set in p2128[0...15] occurs, then the particular binector output r2129.0...15 is set. Refer to: r2129		

r2129.0...15	CO/BO: Faults/alarms trigger word / F/A trigger word		
	Access level: 3	Calculated: -	Data type: Unsigned16
	Can be changed: -	Scaling: -	Dyn. index: -
	Unit group: -	Unit selection: -	Func. diagram: 8070
	Min	Max	Factory setting
	-	-	-
Description:	Display and BICO output for the trigger signals of the faults/alarms set in p2128[0...15].		

2 Parameters

2.2 List of parameters

Bit field:	Bit	Signal name	1 signal	0 signal	FP
	00	Trigger signal p2128[0]	ON	OFF	-
	01	Trigger signal p2128[1]	ON	OFF	-
	02	Trigger signal p2128[2]	ON	OFF	-
	03	Trigger signal p2128[3]	ON	OFF	-
	04	Trigger signal p2128[4]	ON	OFF	-
	05	Trigger signal p2128[5]	ON	OFF	-
	06	Trigger signal p2128[6]	ON	OFF	-
	07	Trigger signal p2128[7]	ON	OFF	-
	08	Trigger signal p2128[8]	ON	OFF	-
	09	Trigger signal p2128[9]	ON	OFF	-
	10	Trigger signal p2128[10]	ON	OFF	-
	11	Trigger signal p2128[11]	ON	OFF	-
	12	Trigger signal p2128[12]	ON	OFF	-
	13	Trigger signal p2128[13]	ON	OFF	-
	14	Trigger signal p2128[14]	ON	OFF	-
	15	Trigger signal p2128[15]	ON	OFF	-

Dependency: If the fault/alarm set in p2128[0...15] occurs, then the particular binector output r2129.0...15 is set.
Refer to: p2128

Note: CO: r2129 = 0 --> None of the selected messages has occurred.
CO: r2129 > 0 --> At least one of the selected messages has occurred.

r2130[0...63]	Fault time received in days / t_fault rcv days		
Access level: 3	Calculated: -	Data type: Unsigned16	
Can be changed: -	Scaling: -	Dyn. index: -	
Unit group: -	Unit selection: -	Func. diagram: 8060	
Min	Max	Factory setting	
-	-	-	

Description: Displays the system runtime in days when the fault occurred.

Dependency: Refer to: r0945, r0947, r0948, r0949, r2109, r2133, r2136

Notice: The time comprises r2130 (days) and r0948 (milliseconds).

The value displayed in r2130 refers to January 1, 1970

Note: The buffer parameters are cyclically updated in the background (refer to status signal in r2139).

r2131	CO: Actual fault code / Act fault code		
Access level: 2	Calculated: -	Data type: Unsigned16	
Can be changed: -	Scaling: -	Dyn. index: -	
Unit group: -	Unit selection: -	Func. diagram: 8060	
Min	Max	Factory setting	
-	-	-	

Description: Displays the code of the oldest active fault.

Dependency: Refer to: r3131, r3132

Note: 0: No fault present.

r2132	CO: Actual alarm code / Actual alarm code		
Access level: 2	Calculated: -	Data type: Unsigned16	
Can be changed: -	Scaling: -	Dyn. index: -	
Unit group: -	Unit selection: -	Func. diagram: 8065	
Min	Max	Factory setting	
-	-	-	

Description: Displays the code of the last alarm that occurred.

Note: 0: No alarm present.

r2133[0...63]	Fault value for float values / Fault val float			
	Access level: 3	Calculated: -	Data type: FloatingPoint32	
	Can be changed: -	Scaling: -	Dyn. index: -	
	Unit group: -	Unit selection: -	Func. diagram: 8060	
	Min	Max	Factory setting	
	-	-	-	
Description:	Displays additional information about the fault that occurred for float values.			
Dependency:	Refer to: r0945, r0947, r0948, r0949, r2109, r2130, r2136			
Note:	The buffer parameters are cyclically updated in the background (refer to status signal in r2139).			
r2134[0...63]	Alarm value for float values / Alarm value float			
	Access level: 3	Calculated: -	Data type: FloatingPoint32	
	Can be changed: -	Scaling: -	Dyn. index: -	
	Unit group: -	Unit selection: -	Func. diagram: 8065	
	Min	Max	Factory setting	
	-	-	-	
Description:	Displays additional information about the active alarm for float values.			
Dependency:	Refer to: r2110, r2122, r2123, r2124, r2125, r2145, r2146, r3121, r3123			
Note:	The buffer parameters are cyclically updated in the background (refer to status signal in r2139).			
r2135.12...15	CO/BO: Status word faults/alarms 2 / ZSW fault/alarm 2			
	Access level: 2	Calculated: -	Data type: Unsigned16	
	Can be changed: -	Scaling: -	Dyn. index: -	
	Unit group: -	Unit selection: -	Func. diagram: 2548	
	Min	Max	Factory setting	
	-	-	-	
Description:	Display and BICO output for the second status word of faults and alarms.			
Bit field:	Bit	Signal name	1 signal	0 signal
	12	Fault motor overtemperature	Yes	No
	13	Fault power unit thermal overload	Yes	No
	14	Alarm motor overtemperature	Yes	No
	15	Alarm power unit thermal overload	Yes	No
				FP
				8016
				8021
				8016
				8021
r2136[0...63]	Fault time removed in days / tflt resolv days			
	Access level: 3	Calculated: -	Data type: Unsigned16	
	Can be changed: -	Scaling: -	Dyn. index: -	
	Unit group: -	Unit selection: -	Func. diagram: 8060	
	Min	Max	Factory setting	
	-	-	-	
Description:	Displays the system runtime in days when the fault was removed.			
Dependency:	Refer to: r0945, r0947, r0948, r0949, r2109, r2130, r2133			
Notice:	The time comprises r2136 (days) and r2109 (milliseconds).			
Note:	The buffer parameters are cyclically updated in the background (refer to status signal in r2139).			
r2138.7...15	CO/BO: Control word faults/alarms / STW fault/alarm			
	Access level: 2	Calculated: -	Data type: Unsigned16	
	Can be changed: -	Scaling: -	Dyn. index: -	
	Unit group: -	Unit selection: -	Func. diagram: 2546	
	Min	Max	Factory setting	
	-	-	-	
Description:	Display and BICO output for the control word of faults and alarms.			

2 Parameters

2.2 List of parameters

Bit field:	Bit	Signal name	1 signal	0 signal	FP
	07	Acknowledge fault	Yes	No	8060
	10	External alarm 1 (A07850) effective	Yes	No	8065
	11	External alarm 2 (A07851) effective	Yes	No	8065
	12	External alarm 3 (A07852) effective	Yes	No	8065
	13	External fault 1 (F07860) effective	Yes	No	8060
	14	External fault 2 (F07861) effective	Yes	No	8060
	15	External fault 3 (F07862) effective	Yes	No	8060

Dependency: Refer to: p2103, p2104, p2105, p2106, p2107, p2108, p2112, p2116, p2117, p3110, p3111, p3112

r2139.0...15 CO/BO: Status word faults/alarms 1 / ZSW fault/alarm 1

Access level: 2	Calculated: -	Data type: Unsigned16
Can be changed: -	Scaling: -	Dyn. index: -
Unit group: -	Unit selection: -	Func. diagram: 2548
Min	Max	Factory setting
-	-	-

Description: Display and BICO output for status word 1 of faults and alarms.

Bit field:	Bit	Signal name	1 signal	0 signal	FP
	00	Being acknowledged	Yes	No	-
	01	Acknowledgment required	Yes	No	-
	03	Fault present	Yes	No	8060
	06	Internal message 1 present	Yes	No	-
	07	Alarm present	Yes	No	8065
	08	Internal message 2 present	Yes	No	-
	11	Alarm class bit 0	High	Low	-
	12	Alarm class bit 1	High	Low	-
	13	Maintenance required	Yes	No	-
	14	Maintenance urgently required	Yes	No	-
	15	Fault gone/can be acknowledged	Yes	No	-

Note: For bit 03, 07:

These bits are set if at least one fault/alarm occurs. Data is entered into the fault/alarm buffer with delay. This is the reason that the fault/alarm buffer should only be read if, after "fault present" or "alarm present" has occurred, a change in the buffer was also detected (r0944, r9744, r2121).

For bit 06, 08:

These status bits are used for internal diagnostic purposes only.

For bits 11, 12:

These status bits are used for the classification of internal alarm classes and are intended for diagnostic purposes only on certain automation systems with integrated SINAMICS functionality.

p2140[0...n] Hysteresis speed 2 / n_hysteresis 2

Access level: 3	Calculated: p0340 = 1,3,5	Data type: FloatingPoint32
Can be changed: U, T	Scaling: -	Dyn. index: DDS, p0180
Unit group: 3_1	Unit selection: p0505	Func. diagram: 8010
Min	Max	Factory setting
0.00 [rpm]	300.00 [rpm]	90.00 [rpm]

Description: Sets the hysteresis speed (bandwidth) for the following signals:

"|n_act| <= speed threshold value 2" (BO: r2197.1)

"|n_act| > speed threshold value 2" (BO: r2197.2)

Dependency: Refer to: p2155, r2197

p2141[0...n] Speed threshold 1 / n_thresh val 1

Access level: 3	Calculated: p0340 = 1,3,5	Data type: FloatingPoint32
Can be changed: U, T	Scaling: -	Dyn. index: DDS, p0180
Unit group: 3_1	Unit selection: p0505	Func. diagram: 8010
Min	Max	Factory setting
0.00 [rpm]	210000.00 [rpm]	5.00 [rpm]

Description: Sets the speed threshold value for the signal "f or n comparison value reached or exceeded" (BO: r2199.1).

Dependency: Refer to: p2142, r2199

p2142[0...n]	Hysteresis speed 1 / n_hysteresis 1		
	Access level: 3	Calculated: p0340 = 1,3,5	Data type: FloatingPoint32
	Can be changed: U, T	Scaling: -	Dyn. index: DDS, p0180
	Unit group: 3_1	Unit selection: p0505	Func. diagram: 8010
	Min	Max	Factory setting
	0.00 [rpm]	300.00 [rpm]	2.00 [rpm]
Description:	Sets the hysteresis speed (bandwidth) for the signal "f or n / v comparison value reached or exceeded" (BO: r2199.1).		
Dependency:	Refer to: p2141, r2199		

p2144[0...n]	BI: Motor stall monitoring enable (negated) / Mot stall enab neg		
	Access level: 4	Calculated: -	Data type: U32 / Binary
	Can be changed: U, T	Scaling: -	Dyn. index: CDS, p0170
	Unit group: -	Unit selection: -	Func. diagram: 8012
	Min	Max	Factory setting
	-	-	0
Description:	Sets the signal source for the negated enable (0 = enable) of the motor stall monitoring.		
Dependency:	Refer to: p2163, p2164, p2166, r2197, r2198 Refer to: F07900		
Note:	When interconnecting the enable signal with r2197.7 then the stall signal is suppressed if there is no speed setpoint - actual value deviation.		

r2145[0...63]	Alarm time received in days / t_alarm rcv days		
	Access level: 3	Calculated: -	Data type: Unsigned16
	Can be changed: -	Scaling: -	Dyn. index: -
	Unit group: -	Unit selection: -	Func. diagram: 8065
	Min	Max	Factory setting
	-	-	-
Description:	Displays the system runtime in days when the alarm occurred.		
Dependency:	Refer to: r2110, r2122, r2123, r2124, r2125, r2134, r2146		
Notice:	The time comprises r2145 (days) and r2123 (milliseconds).		
Note:	The buffer parameters are cyclically updated in the background (refer to status signal in r2139).		

r2146[0...63]	Alarm time removed in days / t_alarm res days		
	Access level: 3	Calculated: -	Data type: Unsigned16
	Can be changed: -	Scaling: -	Dyn. index: -
	Unit group: -	Unit selection: -	Func. diagram: 8065
	Min	Max	Factory setting
	-	-	-
Description:	Displays the system runtime in days when the alarm was cleared.		
Dependency:	Refer to: r2110, r2122, r2123, r2124, r2125, r2134, r2145		
Notice:	The time comprises r2146 (days) and r2125 (milliseconds).		
Note:	The buffer parameters are cyclically updated in the background (refer to status signal in r2139).		

p2148[0...n]	BI: RFG active / RFG active		
	Access level: 3	Calculated: p0340 = 1,3,5	Data type: U32 / Binary
	Can be changed: U, T	Scaling: -	Dyn. index: CDS, p0170
	Unit group: -	Unit selection: -	Func. diagram: 8011
	Min	Max	Factory setting
	-	-	0
Description:	Sets the signal source for the signal "ramp-function generator active" for the following signals/messages: "Speed setpoint - actual value deviation within tolerance t_on" (BO: r2199.4) "Ramp-up/ramp-down completed" (BO: r2199.5)		
Notice:	The parameter may be protected as a result of p0922 or p2079 and cannot be changed.		
Note:	The binector input is automatically interconnected to r1199.2 as a default setting.		

p2149[0...n]	Monitoring configuration / Monit config				
	Access level: 3	Calculated: -	Data type: Unsigned16		
	Can be changed: U, T	Scaling: -	Dyn. index: DDS, p0180		
	Unit group: -	Unit selection: -	Func. diagram: -		
	Min	Max	Factory setting		
	-	-	0000 1001 bin		
Description:	Sets the configuration for messages and monitoring functions.				
Bit field:	Bit	Signal name	1 signal	0 signal	FP
	00	Enable alarm A07903	Yes	No	8011
	01	Load monitoring only in the 1st quadrant	Yes	No	8013
	03	n_act > p2155 own hysteresis	Yes	No	8010
	05	Stall monitoring for encoderless speed control	Yes	No	-
Dependency:	Refer to: r2197 Refer to: A07903				
Note:	For bit 00: Alarm A07903 is output when the bit is set with r2197.7 = 0 (n_set <> n_act). For bit 01: When the bit is set, the load monitoring is only executed in the 1st quadrant as a result of the positive characteristic parameters (p2182 ... p2190). For bit 03: When the bit is set, r2197.1 and r2197.2 are determined using separate hysteresis functions. For bit 05: When this bit is set, a change to open-loop speed controlled operation is only possible when the motor is stationary.				

p2150[0...n]	Hysteresis speed 3 / n_hysteresis 3		
	Access level: 3	Calculated: p0340 = 1,3,5	Data type: FloatingPoint32
	Can be changed: U, T	Scaling: -	Dyn. index: DDS, p0180
	Unit group: 3_1	Unit selection: p0505	Func. diagram: 8010, 8011, 8022
	Min	Max	Factory setting
	0.00 [rpm]	300.00 [rpm]	2.00 [rpm]
Description:	Sets the hysteresis speed (bandwidth) for the following signals: " n_act < speed threshold value 3" (BO: r2199.0) "n_set >= 0" (BO: r2198.5) "n_act >= 0" (BO: r2197.3)		
Dependency:	Refer to: p2161, r2197, r2199		

p2151[0...n]	Cl: Speed setpoint for messages/signals / n_set for msg		
	Access level: 3	Calculated: -	Data type: U32 / FloatingPoint32
	Can be changed: T	Scaling: p2000	Dyn. index: CDS, p0170
	Unit group: -	Unit selection: -	Func. diagram: 8011
	Min	Max	Factory setting
	-	-	1170[0]

Description: Sets the signal source for the speed setpoint for the following messages:
 "Speed setpoint - actual value deviation within tolerance t_off" (BO: r2197.7)
 "Ramp-up/ramp-down completed" (BO: r2199.5)
 "|n_set| < p2161" (BO: r2198.4)
 "n_set > 0" (BO: r2198.5)

Dependency: Refer to: r2197, r2198, r2199

p2152[0...n]	Delay for comparison n > n_max / Del n > n_max		
	Access level: 3	Calculated: -	Data type: Unsigned16
	Can be changed: U, T	Scaling: -	Dyn. index: DDS, p0180
	Unit group: -	Unit selection: -	Func. diagram: 8023
	Min	Max	Factory setting
	0 [ms]	10000 [ms]	200 [ms]

Description: Sets the delay time for comparing the speed with the maximum speed.

Dependency: Refer to: p1082, r1084, r1087, p2162

p2153[0...n]	Speed actual value filter time constant / n_act_filt T		
	Access level: 3	Calculated: -	Data type: FloatingPoint32
	Can be changed: U, T	Scaling: -	Dyn. index: DDS, p0180
	Unit group: -	Unit selection: -	Func. diagram: 8010
	Min	Max	Factory setting
	0 [ms]	1000000 [ms]	0 [ms]

Description: Sets the time constant of the PT1 element to smooth the speed / velocity actual value.
 The smoothed actual speed/velocity is compared with the threshold values and is only used for messages and signals.

Dependency: Refer to: r2169

p2155[0...n]	Speed threshold 2 / n_thresh val 2		
	Access level: 3	Calculated: p0340 = 1,3,5	Data type: FloatingPoint32
	Can be changed: U, T	Scaling: -	Dyn. index: DDS, p0180
	Unit group: 3_1	Unit selection: p0505	Func. diagram: 8010
	Min	Max	Factory setting
	0.00 [rpm]	210000.00 [rpm]	900.00 [rpm]

Description: Sets the speed threshold value for the following messages:

"|n_act| <= speed threshold value 2" (BO: r2197.1)

"|n_act| > speed threshold value 2" (BO: r2197.2)

Dependency: Refer to: p2140, r2197

p2156[0...n]	On delay comparison value reached / t_on cmpr val rchd		
	Access level: 3	Calculated: -	Data type: FloatingPoint32
	Can be changed: U, T	Scaling: -	Dyn. index: DDS, p0180
	Unit group: -	Unit selection: -	Func. diagram: 8010
	Min	Max	Factory setting
	0.0 [ms]	10000.0 [ms]	0.0 [ms]

Description: Sets the switch-in delay time for the signal "comparison value reached" (BO: r2199.1).

Dependency: Refer to: p2141, p2142, r2199

p2157[0...n]	Speed threshold 5 / n_thresh val 5		
	Access level: 3	Calculated: p0340 = 1,3,5	Data type: FloatingPoint32
	Can be changed: U, T	Scaling: -	Dyn. index: DDS, p0180
	Unit group: 3_1	Unit selection: p0505	Func. diagram: -
	Min	Max	Factory setting
	0.00 [rpm]	210000.00 [rpm]	900.00 [rpm]
Description:	Sets the speed threshold value for the following messages: " n_act <= speed threshold value 5" (BO: r2198.0) " n_act > speed threshold value 5" (BO: r2198.1)		
Dependency:	Refer to: p2150, p2158		
p2158[0...n]	Delay for n_act comparison with speed threshold value 5 / Del compar n_5		
	Access level: 3	Calculated: -	Data type: Unsigned16
	Can be changed: U, T	Scaling: -	Dyn. index: DDS, p0180
	Unit group: -	Unit selection: -	Func. diagram: -
	Min	Max	Factory setting
	0 [ms]	10000 [ms]	10 [ms]
Description:	Delay time for the comparison of the speed with the speed threshold value 5 (P2157).		
Dependency:	Refer to: p2150, p2157		
p2159[0...n]	Speed threshold 6 / n_thresh val 6		
	Access level: 3	Calculated: p0340 = 1,3,5	Data type: FloatingPoint32
	Can be changed: U, T	Scaling: -	Dyn. index: DDS, p0180
	Unit group: 3_1	Unit selection: p0505	Func. diagram: -
	Min	Max	Factory setting
	0.00 [rpm]	210000.00 [rpm]	900.00 [rpm]
Description:	Sets the speed threshold value for the following messages: " n_act <= speed threshold value 6" (BO: r2198.2) " n_act > speed threshold value 6" (BO: r2198.3)		
Dependency:	Refer to: p2150, p2160		
p2160[0...n]	Delay for n_act comparison with speed threshold value 6 / Del compar n_6		
	Access level: 3	Calculated: -	Data type: Unsigned16
	Can be changed: U, T	Scaling: -	Dyn. index: DDS, p0180
	Unit group: -	Unit selection: -	Func. diagram: -
	Min	Max	Factory setting
	0 [ms]	10000 [ms]	10 [ms]
Description:	Sets the delay time for the comparison of the speed with the speed threshold value 6 (p2159).		
Dependency:	Refer to: p2150, p2159		
p2161[0...n]	Speed threshold 3 / n_thresh val 3		
	Access level: 3	Calculated: p0340 = 1,3,5	Data type: FloatingPoint32
	Can be changed: U, T	Scaling: -	Dyn. index: DDS, p0180
	Unit group: 3_1	Unit selection: p0505	Func. diagram: 8010, 8011
	Min	Max	Factory setting
	0.00 [rpm]	210000.00 [rpm]	5.00 [rpm]
Description:	Sets the speed threshold value for the signal " n_act < speed threshold value 3" (BO: r2199.0).		
Dependency:	Refer to: p2150, r2199		

p2162[0...n]	Hysteresis speed $n_{act} > n_{max}$ / Hyst $n_{act} > n_{max}$		
	Access level: 3	Calculated: p0340 = 1,3,5	Data type: FloatingPoint32
	Can be changed: U, T	Scaling: -	Dyn. index: DDS, p0180
	Unit group: 3_1	Unit selection: p0505	Func. diagram: 8010
	Min	Max	Factory setting
	0.00 [rpm]	60000.00 [rpm]	0.00 [rpm]
Description:	Sets the hysteresis speed (bandwidth) for the signal " $n_{act} > n_{max}$ " (BO: r2197.6).		
Dependency:	Refer to: r1084, r1087, r2197		
Notice:	For p0322 = 0, the following applies: $p2162 \leq 0.1 * p0311$ For p0322 > 0, the following applies: $p2162 \leq 1.02 * p0322 - p1082$ If one of the conditions is violated, p2162 is appropriately and automatically reduced when exiting the commissioning mode.		
Note:	For a negative speed limit (r1087) the hysteresis is effective below the limit value and for a positive speed limit (r1084) above the limit value. If significant overshoot occurs in the maximum speed range (e.g. due to load shedding), you are advised to increase the dynamic response of the speed controller (if possible). If this is insufficient, the hysteresis p2162 can only be increased by more than 10% of the rated speed when the maximum speed (p0322) of the motor is sufficiently greater than the speed limit p1082.		
p2163[0...n]	Speed threshold 4 / n_{thresh} val 4		
	Access level: 3	Calculated: p0340 = 1,3,5	Data type: FloatingPoint32
	Can be changed: U, T	Scaling: -	Dyn. index: DDS, p0180
	Unit group: 3_1	Unit selection: p0505	Func. diagram: 8011
	Min	Max	Factory setting
	0.00 [rpm]	210000.00 [rpm]	90.00 [rpm]
Description:	Sets the speed threshold value for the "speed setpoint - actual value deviation in tolerance t_{off} " signal/message (BO: r2197.7).		
Dependency:	Refer to: p2164, p2166, r2197		
p2164[0...n]	Hysteresis speed 4 / $n_{hysteresis}$ 4		
	Access level: 3	Calculated: p0340 = 1,3,5	Data type: FloatingPoint32
	Can be changed: U, T	Scaling: -	Dyn. index: DDS, p0180
	Unit group: 3_1	Unit selection: p0505	Func. diagram: 8011
	Min	Max	Factory setting
	0.00 [rpm]	200.00 [rpm]	2.00 [rpm]
Description:	Sets the hysteresis speed (bandwidth) for the "speed setpoint - actual value deviation in tolerance t_{off} " signal/message (BO: r2197.7).		
Dependency:	Refer to: p2163, p2166, r2197		
p2165[0...n]	Load monitoring stall monitoring upper threshold / Stall_mon up thr		
	Access level: 3	Calculated: -	Data type: FloatingPoint32
	Can be changed: U, T	Scaling: -	Dyn. index: DDS, p0180
	Unit group: 3_1	Unit selection: p0505	Func. diagram: 8013
	Min	Max	Factory setting
	0.00 [rpm]	210000.00 [rpm]	0.00 [rpm]
Description:	Sets the upper speed threshold of the stall monitoring of the pump or fan. The lower limit is formed by the speed threshold 1 of the load monitoring (p2182). The stall monitoring is active between p2182 and p2165.		
Dependency:	The following applies: $p2182 < p2165$ Refer to: p2181, p2182, p2193 Refer to: A07891, F07894, A07926		
Note:	For $p2165 = 0$ or $p2165 < p2182$, the following applies: There is no special stall monitoring for the pump/fan, but only the remaining load monitoring functions (e.g. leakage monitoring for a pump) for the pump or fan are active.		

p2166[0...n]	Off delay $n_{act} = n_{set} / t_{del_off} n_i = n_{so}$		
	Access level: 3	Calculated: -	Data type: FloatingPoint32
	Can be changed: U, T	Scaling: -	Dyn. index: DDS, p0180
	Unit group: -	Unit selection: -	Func. diagram: 8011
	Min	Max	Factory setting
	0.0 [ms]	10000.0 [ms]	200.0 [ms]
Description:	Sets the switch-off delay time for the "speed setpoint - actual value deviation in tolerance t_{off} " signal/message (BO: r2197.7).		
Dependency:	Refer to: p2163, p2164, r2197		
p2167[0...n]	Switch-on delay $n_{act} = n_{set} / t_{on} n_{act} = n_{set}$		
	Access level: 3	Calculated: -	Data type: FloatingPoint32
	Can be changed: U, T	Scaling: -	Dyn. index: DDS, p0180
	Unit group: -	Unit selection: -	Func. diagram: 8011
	Min	Max	Factory setting
	0.0 [ms]	10000.0 [ms]	200.0 [ms]
Description:	Sets the switch-on delay for the "speed setpoint - actual value deviation in tolerance t_{on} " signal/message (BO: r2199.4).		
p2168[0...n]	Load monitoring stall monitoring torque threshold / Stall_mon M_thresh		
	Access level: 3	Calculated: -	Data type: FloatingPoint32
	Can be changed: U, T	Scaling: -	Dyn. index: DDS, p0180
	Unit group: 7_1	Unit selection: p0505	Func. diagram: 8013
	Min	Max	Factory setting
	0.00 [Nm]	20000000.00 [Nm]	10000000.00 [Nm]
Description:	Sets the torque threshold of the stall monitoring of the pump or fan. If, in the monitored speed range from p2182 to p2165, the torque exceeds this threshold, then this is evaluated as either the motor having stalled or heavy-duty starting.		
Dependency:	For pumps, the following applies (p2193 = 4): - the leakage characteristic must lie below the torque threshold for the stall monitoring - the torque threshold for dry running operation must lie below the torque threshold for stall monitoring For fans, the following applies (p2193 = 5): - the torque threshold for the stall monitoring must lie above the torque threshold to identify belt breakage (p2191). Refer to: p2165, p2181, p2191, p2193 Refer to: A07891, F07894, A07926		
Note:	The following applies for p2168 = 0: The special stall monitoring for pump/fan is deactivated. Then, only the remaining load monitoring functions (e.g. the leakage monitoring for a pump) for pump or fan are realized.		
r2169	CO: Actual speed smoothed signals / n_{act} smth message		
	Access level: 2	Calculated: -	Data type: FloatingPoint32
	Can be changed: -	Scaling: p2000	Dyn. index: -
	Unit group: 3_1	Unit selection: p0505	Func. diagram: 8010
	Min	Max	Factory setting
	- [rpm]	- [rpm]	- [rpm]
Description:	Display and connector output of the smoothed speed actual value for messages.		
Dependency:	Refer to: p2153		

p2170[0...n]	Current threshold value / I_thres		
	Access level: 3	Calculated: p0340 = 1,3,5	Data type: FloatingPoint32
	Can be changed: U, T	Scaling: p2002	Dyn. index: DDS, p0180
	Unit group: 6_2	Unit selection: p0505	Func. diagram: 8022
	Min	Max	Factory setting
	0.00 [Arms]	10000.00 [Arms]	0.00 [Arms]
Description:	Sets the absolute current threshold for the messages. "I_act >= I_threshold p2170" (BO: r2197.8) "I_act < I_threshold p2170" (BO: r2198.8)		
Dependency:	Refer to: p2171		
p2171[0...n]	Current threshold value reached delay time / I_thresh rch t_del		
	Access level: 3	Calculated: -	Data type: Unsigned16
	Can be changed: U, T	Scaling: -	Dyn. index: DDS, p0180
	Unit group: -	Unit selection: -	Func. diagram: 8022
	Min	Max	Factory setting
	0 [ms]	10000 [ms]	10 [ms]
Description:	Sets the delay time for the comparison of the current actual value (r0068) with the current threshold value (p2170).		
Dependency:	Refer to: p2170		
p2172[0...n]	DC link voltage threshold value / Vdc thresh val		
	Access level: 3	Calculated: -	Data type: FloatingPoint32
	Can be changed: U, T	Scaling: p2001	Dyn. index: DDS, p0180
	Unit group: 5_2	Unit selection: p0505	Func. diagram: -
	Min	Max	Factory setting
	0 [V]	2000 [V]	800 [V]
Description:	Sets the DC link voltage threshold value for the following messages: "Vdc_act <= Vdc_threshold p2172" (BO: r2197.9) "Vdc_act > Vdc_threshold p2172" (BO: r2197.10)		
Dependency:	Refer to: p2173		
p2173[0...n]	DC link voltage comparison delay time / t_del Vdc		
	Access level: 3	Calculated: -	Data type: Unsigned16
	Can be changed: U, T	Scaling: -	Dyn. index: DDS, p0180
	Unit group: -	Unit selection: -	Func. diagram: -
	Min	Max	Factory setting
	0 [ms]	10000 [ms]	10 [ms]
Description:	Sets the delay time for the comparison of the DC link voltage r0070 with the threshold value p2172.		
Dependency:	Refer to: p2172		
p2174[0...n]	Torque threshold value 1 / M_thresh val 1		
	Access level: 3	Calculated: -	Data type: FloatingPoint32
	Can be changed: U, T	Scaling: -	Dyn. index: DDS, p0180
	Unit group: 7_1	Unit selection: p0505	Func. diagram: 8012
	Min	Max	Factory setting
	0.00 [Nm]	20000000.00 [Nm]	5.13 [Nm]
Description:	Sets the torque threshold value for the messages: "Torque setpoint < torque threshold value 1 and n_set reached" (BO: r2198.9) "Torque setpoint < torque threshold value 1" (BO: r2198.10) "Torque setpoint > torque threshold value 1" (BO: r2198.13)		
Dependency:	Refer to: p2195, r2198		

p2175[0...n]	Motor blocked speed threshold / Mot lock n_thresh		
	Access level: 3	Calculated: p0340 = 1,3,5	Data type: FloatingPoint32
	Can be changed: U, T	Scaling: -	Dyn. index: DDS, p0180
	Unit group: 3_1	Unit selection: p0505	Func. diagram: 8012
	Min	Max	Factory setting
	0.00 [rpm]	210000.00 [rpm]	120.00 [rpm]
Description:	Sets the speed threshold for the message "Motor blocked" (BO: r2198.6).		
Dependency:	Refer to: p0500, p2177, r2198 Refer to: F07900		
Note:	The following applies for sensorless vector control for induction motors: At low speeds in open-loop speed controlled operation (see p1755, p1756), a blocked motor cannot be detected. The following applies for sensorless vector control for permanent magnet synchronous motors: At low speeds in open-loop speed controlled operation (see p1755, p1756), a blocked motor can only be detected if p2175 = p1755, and p1750.6 is set to 1.		
p2176[0...n]	Torque threshold value comparison delay time / M_thrsh comp T_del		
	Access level: 3	Calculated: -	Data type: Unsigned16
	Can be changed: U, T	Scaling: -	Dyn. index: DDS, p0180
	Unit group: -	Unit selection: -	Func. diagram: -
	Min	Max	Factory setting
	0 [ms]	10000 [ms]	200 [ms]
Description:	Sets the delay time for the comparison of the torque actual value (r0080) with torque threshold value 1 (p2174).		
Dependency:	Refer to: p2174		
p2177[0...n]	Motor blocked delay time / Mot lock t_del		
	Access level: 3	Calculated: p0340 = 1,3,5	Data type: FloatingPoint32
	Can be changed: U, T	Scaling: -	Dyn. index: DDS, p0180
	Unit group: -	Unit selection: -	Func. diagram: 8012
	Min	Max	Factory setting
	0.000 [s]	65.000 [s]	3.000 [s]
Description:	Sets the delay time for the message "Motor blocked" (BO: r2198.6).		
Dependency:	Refer to: p0500, p2175, r2198 Refer to: F07900		
Note:	The following applies for sensorless vector control: At low speeds a locked motor can only be detected if no change is made to open-loop speed controlled operation. If this is the case, the value in p2177 must be reduced accordingly (p2177 < p1758) before time p2177 has elapsed in order to detect the locked state reliably. As countermeasure, it is generally also possible to set p1750.6. This is only not permitted if the drive is slowly reversed by the load at the torque limit (speed below p1755 for longer than p1758).		
p2178[0...n]	Motor stalled delay time / Mot stall t_del		
	Access level: 3	Calculated: p0340 = 1,3	Data type: FloatingPoint32
	Can be changed: U, T	Scaling: -	Dyn. index: DDS, p0180
	Unit group: -	Unit selection: -	Func. diagram: 8012
	Min	Max	Factory setting
	0.000 [s]	10.000 [s]	0.010 [s]
Description:	Sets the delay time for the message "Motor stalled" (BO: r2198.7).		
Dependency:	Refer to: r2198		
Note:	In the open-loop speed controlled operating range (see p1755, p1756), vector control stall monitoring depends on threshold p1745. At higher speeds, the difference between flux setpoint r0083 and flux actual value r0084 is monitored.		

p2179[0...n]	Output load identification current limit / Outp_Id iden I_lim		
	Access level: 3	Calculated: p0340 = 1,3,5	Data type: FloatingPoint32
	Can be changed: U, T	Scaling: p2002	Dyn. index: DDS, p0180
	Unit group: 6_2	Unit selection: p0505	Func. diagram: 8022
	Min	Max	Factory setting
	0.00 [Arms]	1000.00 [Arms]	0.00 [Arms]
Description:	Sets the current limit for output load identification. A missing output load is displayed using the "Output load not available" message (r2197.11 = 1). This message is output with a delay time (p2180).		
Dependency:	Refer to: p2180		
Notice:	For synchronous motors the output current can be almost zero under no load conditions.		
Note:	Missing output load is signaled in the following cases: - the motor is not connected. - a phase failure has occurred.		
p2180[0...n]	Output load detection delay time / Out_load det t_del		
	Access level: 3	Calculated: -	Data type: Unsigned16
	Can be changed: U, T	Scaling: -	Dyn. index: DDS, p0180
	Unit group: -	Unit selection: -	Func. diagram: 8022
	Min	Max	Factory setting
	0 [ms]	10000 [ms]	2000 [ms]
Description:	Sets the delay time for the message "output load not available" (r2197.11 = 1).		
Dependency:	Refer to: p2179		
p2181[0...n]	Load monitoring response / Load monit resp		
	Access level: 3	Calculated: -	Data type: Integer16
	Can be changed: U, T	Scaling: -	Dyn. index: DDS, p0180
	Unit group: -	Unit selection: -	Func. diagram: 8013
	Min	Max	Factory setting
	0	8	0
Description:	Sets the response when evaluating the load monitoring.		
Value:	0: Load monitoring disabled 1: A07920 for torque/speed too low 2: A07921 for torque/speed too high 3: A07922 for torque/speed out of tolerance 4: F07923 for torque/speed too low 5: F07924 for torque/speed too high 6: F07925 for torque/speed out of tolerance 7: Pump/fan load monitoring as alarm 8: Pump/fan load monitoring as fault		
Dependency:	Refer to: p2182, p2183, p2184, p2185, p2186, p2187, p2188, p2189, p2190, p2192, p2193, r2198, p3230, p3231 Refer to: A07891, A07892, A07893, F07894, F07895, F07896, A07920, A07921, A07922, F07923, F07924, F07925		
Note:	The response to the faults F07923 ... F07925 can be set. This parameter setting has no effect on the generation of fault F07936. p2181 = 7, 8 can only be combined with p2193 = 4, 5.		

p2182[0...n]	Load monitoring speed threshold value 1 / n_thresh 1		
	Access level: 3	Calculated: -	Data type: FloatingPoint32
	Can be changed: U, T	Scaling: -	Dyn. index: DDS, p0180
	Unit group: 3_1	Unit selection: p0505	Func. diagram: 8013
	Min	Max	Factory setting
	0.00 [rpm]	210000.00 [rpm]	150.00 [rpm]
Description:	Sets the speed/torque envelope curve for load monitoring. The envelope curve (upper and lower envelope curve) is defined as follows based on 3 speed thresholds: p2182 (n_threshold 1) --> p2185 (M_threshold 1, upper), p2186 (M_threshold 1, lower) p2183 (n_threshold 2) --> p2187 (M_threshold 2, upper), p2188 (M_threshold 2, lower) p2184 (n_threshold 3) --> p2189 (M_threshold 3, upper), p2190 (M_threshold 3, lower)		
Dependency:	The following applies: p2182 < p2183 < p2184 Refer to: p2183, p2184, p2185, p2186 Refer to: A07926		
Note:	In order that the load monitoring can reliably respond, the speed threshold p2182 should always be set lower than the minimum motor speed to be monitored.		
p2183[0...n]	Load monitoring speed threshold value 2 / n_thresh 2		
	Access level: 3	Calculated: -	Data type: FloatingPoint32
	Can be changed: U, T	Scaling: -	Dyn. index: DDS, p0180
	Unit group: 3_1	Unit selection: p0505	Func. diagram: 8013
	Min	Max	Factory setting
	0.00 [rpm]	210000.00 [rpm]	900.00 [rpm]
Description:	Sets the speed/torque envelope curve for load monitoring. The envelope curve (upper and lower envelope curve) is defined as follows based on 3 speed thresholds: p2182 (n_threshold 1) --> p2185 (M_threshold 1, upper), p2186 (M_threshold 1, lower) p2183 (n_threshold 2) --> p2187 (M_threshold 2, upper), p2188 (M_threshold 2, lower) p2184 (n_threshold 3) --> p2189 (M_threshold 3, upper), p2190 (M_threshold 3, lower)		
Dependency:	The following applies: p2182 < p2183 < p2184 Refer to: p2182, p2184, p2187, p2188 Refer to: A07926		
p2184[0...n]	Load monitoring speed threshold value 3 / n_thresh 3		
	Access level: 3	Calculated: -	Data type: FloatingPoint32
	Can be changed: U, T	Scaling: -	Dyn. index: DDS, p0180
	Unit group: 3_1	Unit selection: p0505	Func. diagram: 8013
	Min	Max	Factory setting
	0.00 [rpm]	210000.00 [rpm]	1500.00 [rpm]
Description:	Sets the speed/torque envelope curve for load monitoring. The envelope curve (upper and lower envelope curve) is defined as follows based on 3 speed thresholds: p2182 (n_threshold 1) --> p2185 (M_threshold 1, upper), p2186 (M_threshold 1, lower) p2183 (n_threshold 2) --> p2187 (M_threshold 2, upper), p2188 (M_threshold 2, lower) p2184 (n_threshold 3) --> p2189 (M_threshold 3, upper), p2190 (M_threshold 3, lower)		
Dependency:	The following applies: p2182 < p2183 < p2184 Refer to: p2182, p2183, p2189, p2190 Refer to: A07926		
Note:	In order that the load monitoring can reliably respond, the speed threshold p2184 should always be set higher than the maximum motor speed to be monitored.		

p2185[0...n]	Load monitoring torque threshold 1 upper / M_thresh 1 upper		
	Access level: 3	Calculated: -	Data type: FloatingPoint32
	Can be changed: U, T	Scaling: -	Dyn. index: DDS, p0180
	Unit group: 7_1	Unit selection: p0505	Func. diagram: 8013
	Min	Max	Factory setting
	0.00 [Nm]	20000000.00 [Nm]	10000000.00 [Nm]
Description:	Sets the speed/torque envelope curve for load monitoring.		
Dependency:	The following applies: p2185 > p2186 Refer to: p2182, p2186 Refer to: A07926		
Note:	The upper envelope curve is defined by p2185, p2187 and p2189.		
p2186[0...n]	Load monitoring torque threshold 1 lower / M_thresh 1 lower		
	Access level: 3	Calculated: -	Data type: FloatingPoint32
	Can be changed: U, T	Scaling: -	Dyn. index: DDS, p0180
	Unit group: 7_1	Unit selection: p0505	Func. diagram: 8013
	Min	Max	Factory setting
	0.00 [Nm]	20000000.00 [Nm]	0.00 [Nm]
Description:	Sets the speed/torque envelope curve for load monitoring.		
Dependency:	The following applies: p2186 < p2185 Refer to: p2182, p2185 Refer to: A07926		
Note:	The lower envelope curve is defined by p2186, p2188 and p2190.		
p2187[0...n]	Load monitoring torque threshold 2 upper / M_thresh 2 upper		
	Access level: 3	Calculated: -	Data type: FloatingPoint32
	Can be changed: U, T	Scaling: -	Dyn. index: DDS, p0180
	Unit group: 7_1	Unit selection: p0505	Func. diagram: 8013
	Min	Max	Factory setting
	0.00 [Nm]	20000000.00 [Nm]	10000000.00 [Nm]
Description:	Sets the speed/torque envelope curve for load monitoring.		
Dependency:	The following applies: p2187 > p2188 Refer to: p2183, p2188 Refer to: A07926		
Note:	The upper envelope curve is defined by p2185, p2187 and p2189.		
p2188[0...n]	Load monitoring torque threshold 2 lower / M_thresh 2 lower		
	Access level: 3	Calculated: -	Data type: FloatingPoint32
	Can be changed: U, T	Scaling: -	Dyn. index: DDS, p0180
	Unit group: 7_1	Unit selection: p0505	Func. diagram: 8013
	Min	Max	Factory setting
	0.00 [Nm]	20000000.00 [Nm]	0.00 [Nm]
Description:	Sets the speed/torque envelope curve for load monitoring.		
Dependency:	The following applies: p2188 < p2187 Refer to: p2183, p2187 Refer to: A07926		
Note:	The lower envelope curve is defined by p2186, p2188 and p2190.		

p2189[0...n]	Load monitoring torque threshold 3 upper / M_thresh 3 upper		
	Access level: 3	Calculated: -	Data type: FloatingPoint32
	Can be changed: U, T	Scaling: -	Dyn. index: DDS, p0180
	Unit group: 7_1	Unit selection: p0505	Func. diagram: 8013
	Min	Max	Factory setting
	0.00 [Nm]	20000000.00 [Nm]	10000000.00 [Nm]
Description:	Sets the speed/torque envelope curve for load monitoring.		
Dependency:	The following applies: p2189 > p2190 Refer to: p2184, p2190 Refer to: A07926		
Note:	The upper envelope curve is defined by p2185, p2187 and p2189.		
p2190[0...n]	Load monitoring torque threshold 3 lower / M_thresh 3 lower		
	Access level: 3	Calculated: -	Data type: FloatingPoint32
	Can be changed: U, T	Scaling: -	Dyn. index: DDS, p0180
	Unit group: 7_1	Unit selection: p0505	Func. diagram: 8013
	Min	Max	Factory setting
	0.00 [Nm]	20000000.00 [Nm]	0.00 [Nm]
Description:	Sets the speed/torque envelope curve for load monitoring.		
Dependency:	The following applies: p2190 < p2189 Refer to: p2184, p2189 Refer to: A07926		
Note:	The lower envelope curve is defined by p2186, p2188 and p2190.		
p2191[0...n]	Load monitoring torque threshold no load / M_thresh no load		
	Access level: 3	Calculated: -	Data type: FloatingPoint32
	Can be changed: U, T	Scaling: -	Dyn. index: DDS, p0180
	Unit group: 7_1	Unit selection: p0505	Func. diagram: 8013
	Min	Max	Factory setting
	0.00 [Nm]	20000000.00 [Nm]	0.00 [Nm]
Description:	Setting of the torque threshold to identify dry running operation for pumps or belt breakage for fans.		
Dependency:	The following applies: p2191 < p2168 if p2168 <> 0 Refer to: p2181, p2182, p2184, p2193 Refer to: A07892, F07895, A07926		
Note:	For the setting p2191 = 0, the monitoring for dry running operation or belt breakage is deactivated. Pre-assignment: p2191 = 5 % of the rated motor torque (p0333).		
p2192[0...n]	Load monitoring delay time / Load monit t_del		
	Access level: 3	Calculated: -	Data type: FloatingPoint32
	Can be changed: U, T	Scaling: -	Dyn. index: DDS, p0180
	Unit group: -	Unit selection: -	Func. diagram: 8013
	Min	Max	Factory setting
	0.00 [s]	65.00 [s]	10.00 [s]
Description:	Sets the delay time to evaluate the load monitoring.		
p2193[0...n]	Load monitoring configuration / Load monit config		
	Access level: 3	Calculated: -	Data type: Integer16
	Can be changed: U, T	Scaling: -	Dyn. index: DDS, p0180
	Unit group: -	Unit selection: -	Func. diagram: 8013
	Min	Max	Factory setting
	0	5	1
Description:	Sets the load monitoring configuration.		

Value:	0: Monitoring switched out 1: Monitoring torque and load drop 2: Monitoring speed and load drop 3: Monitoring load drop 4: Monitoring pump and load failure 5: Monitoring fan and load failure
Dependency:	Refer to: p2182, p2183, p2184, p2185, p2186, p2187, p2188, p2189, p2190, p2192, r2198, p3230, p3231, p3232 Refer to: A07891, A07892, A07893, F07894, F07895, F07896, A07920, A07921, A07922, F07923, F07924, F07925, F07936
Note:	p2193 = 4, 5 can only be combined with p2181 = 7, 8.

p2194[0...n]	Torque threshold value 2 / M_thresh val 2
Access level: 3	Calculated: p0340 = 1,3,5
Can be changed: U, T	Scaling: -
Unit group: -	Unit selection: -
Min	Max
0.00 [%]	100.00 [%]
	Factory setting
	90.00 [%]
Description:	Sets the torque threshold value for the message "Torque utilization < torque threshold value 2" (BO: r2199.11). The message "torque setpoint < p2174" (BO: r2198.10) and "torque utilization < p2194" (BO: r2199.11) are only evaluated after the run-up and the delay time has expired.
Dependency:	Refer to: r0033, p2195, r2199

p2195[0...n]	Torque utilization switch-off delay / M_util t_off
Access level: 3	Calculated: -
Can be changed: U, T	Scaling: -
Unit group: -	Unit selection: -
Min	Max
0.0 [ms]	1000.0 [ms]
	Factory setting
	800.0 [ms]
Description:	Sets the switch-off delay time for the negated signal "run-up completed". The message "torque setpoint < p2174" (BO: r2198.10) and "torque utilization < p2194" (BO: r2199.11) are only evaluated after the run-up and the delay time has expired.
Dependency:	Refer to: p2174, p2194

p2196[0...n]	Torque utilization scaling / M_util scal
Access level: 1	Calculated: -
Can be changed: C(1), U, T	Scaling: -
Unit group: -	Unit selection: -
Min	Max
0.00 [%]	1000.00 [%]
	Factory setting
	100.00 [%]
Description:	Sets the scaling factor for torque utilization (r0033).

r2197.0...13	CO/BO: Status word monitoring 1 / ZSW monitor 1
Access level: 3	Calculated: -
Can be changed: -	Scaling: -
Unit group: -	Unit selection: -
Min	Max
-	-
	Factory setting
	-
Description:	Display and BICO output for the first status word of the monitoring functions.

2 Parameters

2.2 List of parameters

Bit field:	Bit	Signal name	1 signal	0 signal	FP
	00	n_act <= n_min p1080	Yes	No	8022
	01	n_act <= speed threshold value 2 p2155	Yes	No	8010
	02	n_act > speed threshold value 2 p2155	Yes	No	8010
	03	n_act >= 0	Yes	No	8011
	04	n_act >= n_set	Yes	No	8022
	05	n_act <= n_standstill p1226	Yes	No	8022
	06	n_act > n_max	Yes	No	8010
	07	Speed setpoint - actual value deviation in tolerance t_off	Yes	No	8011
	08	I_act >= I_threshold value p2170	Yes	No	8022
	09	Vdc_act <= Vdc_threshold value p2172	Yes	No	8022
	10	Vdc_act > Vdc_threshold value p2172	Yes	No	8022
	11	Output load is not present	Yes	No	8022
	12	n_act > n_max (delayed)	Yes	No	8023
	13	n_act > n_max (F07901)	Yes	No	-

Notice: For bit 06:
When the overspeed is reached, this bit is set and F07901 output immediately following this. The bit is canceled again as soon as the next pulse inhibit is present.

Note: For bit 00:
The threshold value is set in p1080 and the hysteresis in p2150.
For bit 01, 02:
The threshold value is set in p2155 and the hysteresis in p2140.
For bit 03:
1 signal direction of rotation positive.
0 signal: direction of rotation negative.
The hysteresis is set in p2150.
For bit 04:
The threshold value is set in r1119 and the hysteresis in p2150.
For bit 05:
The threshold value is set in p1226 and the delay time in p1228.
For bit 06:
The hysteresis is set in p2162.
For bit 07:
The threshold value is set in p2163 and the hysteresis is set in p2164.
For bit 08:
The threshold value is set in p2170 and the delay time in p2171.
For bit 09, 10:
The threshold value is set in p2172 and the delay time in p2173.
For bit 11:
The threshold value is set in p2179 and the delay time in p2180.
For bit 12:
The threshold value is set in p2182 and the hysteresis is set in p2162.
When p2152 is available, the delay time to withdraw the signal can be adapted.
For bit 13:
Only for internal Siemens use.

r2198.0...13

CO/BO: Status word monitoring 2 / ZSW monitor 2

Access level: 3	Calculated: -	Data type: Unsigned16
Can be changed: -	Scaling: -	Dyn. index: -
Unit group: -	Unit selection: -	Func. diagram: 2536
Min	Max	Factory setting
-	-	-

Description: Display and BICO output for the second status word of the monitoring functions.

Bit field:	Bit	Signal name	1 signal	0 signal	FP
	00	n_act <= speed threshold value 5	Yes	No	8023
	01	n_act > speed threshold value 5	Yes	No	8023
	02	n_act <= speed threshold value 6	Yes	No	8023
	03	n_act > speed threshold value 6	Yes	No	8023
	04	n_set < p2161	Yes	No	8011
	05	n_set > 0	Yes	No	8011
	06	Motor blocked	Yes	No	8012
	07	Motor stalled	Yes	No	8012
	08	I_act < I_threshold value p2170	Yes	No	8022
	09	M_act > torque threshold value 1 and n_set reached	Yes	No	8023
	10	M_set < torque threshold value 1	Yes	No	8012
	11	Load in the alarm range	Yes	No	8013
	12	Load in the fault range	Yes	No	8013
	13	M_act > torque threshold value 1	Yes	No	8023

Note: For bit 10:
The torque threshold value 1 is set in p2174.
For bit 12:
This bit is reset after the fault cause disappears, even if the fault itself is still present.

r2199.0...11 CO/BO: Status word monitoring 3 / ZSW monitor 3

Access level: 3	Calculated: -	Data type: Unsigned16
Can be changed: -	Scaling: -	Dyn. index: -
Unit group: -	Unit selection: -	Func. diagram: 2537
Min	Max	Factory setting
-	-	-

Description: Display and BICO output for the third status word of the monitoring functions.

Bit field:	Bit	Signal name	1 signal	0 signal	FP
	00	n_act < speed threshold value 3	Yes	No	8010
	01	f or n comparison value reached or exceeded	Yes	No	8010
	04	Speed setpoint - actual value deviation in tolerance t_on	Yes	No	8011
	05	Ramp-up/ramp-down completed	Yes	No	8011
	11	Torque utilization < torque threshold value 2	Yes	No	8012

Note: For bit 00:
The speed threshold value 3 is set in p2161.
For bit 01:
The comparison value is set in p2141. We recommend setting the hysteresis (p2142) for canceling the bit to a value lower than that in p2141. Otherwise, the bit is not reset.
For bit 11:
The torque threshold value 2 is set in p2194.

p2200[0...n] BI: Technology controller enable / Tec_ctrl enable

Access level: 2	Calculated: -	Data type: U32 / Binary
Can be changed: T	Scaling: -	Dyn. index: CDS, p0170
Unit group: -	Unit selection: -	Func. diagram: 7958
Min	Max	Factory setting
-	-	0

Description: Sets the signal source to switch in/switch out the technology controller.
The technology controller is switched in with a 1 signal.

p2201[0...n]	CO: Technology controller fixed value 1 / Tec_ctrl fix val1		
	Access level: 2	Calculated: -	Data type: FloatingPoint32
	Can be changed: U, T	Scaling: PERCENT	Dyn. index: DDS, p0180
	Unit group: 9_1	Unit selection: p0595	Func. diagram: 7950, 7951
	Min	Max	Factory setting
	-200.00 [%]	200.00 [%]	10.00 [%]
Description:	Sets the value for fixed value 1 of the technology controller.		
Dependency:	Refer to: p2220, p2221, p2222, p2223, r2224, r2229		
Notice:	A BICO interconnection to a parameter that belongs to a drive data set always acts on the effective data set.		
p2202[0...n]	CO: Technology controller fixed value 2 / Tec_ctrl fix val 2		
	Access level: 2	Calculated: -	Data type: FloatingPoint32
	Can be changed: U, T	Scaling: PERCENT	Dyn. index: DDS, p0180
	Unit group: 9_1	Unit selection: p0595	Func. diagram: 7950, 7951
	Min	Max	Factory setting
	-200.00 [%]	200.00 [%]	20.00 [%]
Description:	Sets the value for fixed value 2 of the technology controller.		
Dependency:	Refer to: p2220, p2221, p2222, p2223, r2224, r2229		
Notice:	A BICO interconnection to a parameter that belongs to a drive data set always acts on the effective data set.		
p2203[0...n]	CO: Technology controller fixed value 3 / Tec_ctrl fix val 3		
	Access level: 2	Calculated: -	Data type: FloatingPoint32
	Can be changed: U, T	Scaling: PERCENT	Dyn. index: DDS, p0180
	Unit group: 9_1	Unit selection: p0595	Func. diagram: 7950, 7951
	Min	Max	Factory setting
	-200.00 [%]	200.00 [%]	30.00 [%]
Description:	Sets the value for fixed value 3 of the technology controller.		
Dependency:	Refer to: p2220, p2221, p2222, p2223, r2224, r2229		
Notice:	A BICO interconnection to a parameter that belongs to a drive data set always acts on the effective data set.		
p2204[0...n]	CO: Technology controller fixed value 4 / Tec_ctrl fix val 4		
	Access level: 2	Calculated: -	Data type: FloatingPoint32
	Can be changed: U, T	Scaling: PERCENT	Dyn. index: DDS, p0180
	Unit group: 9_1	Unit selection: p0595	Func. diagram: 7950, 7951
	Min	Max	Factory setting
	-200.00 [%]	200.00 [%]	40.00 [%]
Description:	Sets the value for fixed value 4 of the technology controller.		
Dependency:	Refer to: p2220, p2221, p2222, p2223, r2224, r2229		
Notice:	A BICO interconnection to a parameter that belongs to a drive data set always acts on the effective data set.		
p2205[0...n]	CO: Technology controller fixed value 5 / Tec_ctrl fix val 5		
	Access level: 2	Calculated: -	Data type: FloatingPoint32
	Can be changed: U, T	Scaling: PERCENT	Dyn. index: DDS, p0180
	Unit group: 9_1	Unit selection: p0595	Func. diagram: 7950
	Min	Max	Factory setting
	-200.00 [%]	200.00 [%]	50.00 [%]
Description:	Sets the value for fixed value 5 of the technology controller.		
Dependency:	Refer to: p2220, p2221, p2222, p2223, r2224, r2229		
Notice:	A BICO interconnection to a parameter that belongs to a drive data set always acts on the effective data set.		

p2206[0...n]	CO: Technology controller fixed value 6 / Tec_ctr fix val 6		
	Access level: 2	Calculated: -	Data type: FloatingPoint32
	Can be changed: U, T	Scaling: PERCENT	Dyn. index: DDS, p0180
	Unit group: 9_1	Unit selection: p0595	Func. diagram: 7950
	Min	Max	Factory setting
	-200.00 [%]	200.00 [%]	60.00 [%]
Description:	Sets the value for fixed value 6 of the technology controller.		
Dependency:	Refer to: p2220, p2221, p2222, p2223, r2224, r2229		
Notice:	A BICO interconnection to a parameter that belongs to a drive data set always acts on the effective data set.		
p2207[0...n]	CO: Technology controller fixed value 7 / Tec_ctr fix val 7		
	Access level: 2	Calculated: -	Data type: FloatingPoint32
	Can be changed: U, T	Scaling: PERCENT	Dyn. index: DDS, p0180
	Unit group: 9_1	Unit selection: p0595	Func. diagram: 7950
	Min	Max	Factory setting
	-200.00 [%]	200.00 [%]	70.00 [%]
Description:	Sets the value for fixed value 7 of the technology controller.		
Dependency:	Refer to: p2220, p2221, p2222, p2223, r2224, r2229		
Notice:	A BICO interconnection to a parameter that belongs to a drive data set always acts on the effective data set.		
p2208[0...n]	CO: Technology controller fixed value 8 / Tec_ctr fix val 8		
	Access level: 2	Calculated: -	Data type: FloatingPoint32
	Can be changed: U, T	Scaling: PERCENT	Dyn. index: DDS, p0180
	Unit group: 9_1	Unit selection: p0595	Func. diagram: 7950
	Min	Max	Factory setting
	-200.00 [%]	200.00 [%]	80.00 [%]
Description:	Sets the value for fixed value 8 of the technology controller.		
Dependency:	Refer to: p2220, p2221, p2222, p2223, r2224, r2229		
Notice:	A BICO interconnection to a parameter that belongs to a drive data set always acts on the effective data set.		
p2209[0...n]	CO: Technology controller fixed value 9 / Tec_ctr fix val 9		
	Access level: 2	Calculated: -	Data type: FloatingPoint32
	Can be changed: U, T	Scaling: PERCENT	Dyn. index: DDS, p0180
	Unit group: 9_1	Unit selection: p0595	Func. diagram: 7950
	Min	Max	Factory setting
	-200.00 [%]	200.00 [%]	90.00 [%]
Description:	Sets the value for fixed value 9 of the technology controller.		
Dependency:	Refer to: p2220, p2221, p2222, p2223, r2224, r2229		
Notice:	A BICO interconnection to a parameter that belongs to a drive data set always acts on the effective data set.		
p2210[0...n]	CO: Technology controller fixed value 10 / Tec_ctr fix val 10		
	Access level: 2	Calculated: -	Data type: FloatingPoint32
	Can be changed: U, T	Scaling: PERCENT	Dyn. index: DDS, p0180
	Unit group: 9_1	Unit selection: p0595	Func. diagram: 7950
	Min	Max	Factory setting
	-200.00 [%]	200.00 [%]	100.00 [%]
Description:	Sets the value for fixed value 10 of the technology controller.		
Dependency:	Refer to: p2220, p2221, p2222, p2223, r2224, r2229		
Notice:	A BICO interconnection to a parameter that belongs to a drive data set always acts on the effective data set.		

p2211[0...n]	CO: Technology controller fixed value 11 / Tec_ctr fix val 11		
	Access level: 2	Calculated: -	Data type: FloatingPoint32
	Can be changed: U, T	Scaling: PERCENT	Dyn. index: DDS, p0180
	Unit group: 9_1	Unit selection: p0595	Func. diagram: 7950
	Min	Max	Factory setting
	-200.00 [%]	200.00 [%]	110.00 [%]
Description:	Sets the value for fixed value 11 of the technology controller.		
Dependency:	Refer to: p2220, p2221, p2222, p2223, r2224, r2229		
Notice:	A BICO interconnection to a parameter that belongs to a drive data set always acts on the effective data set.		
p2212[0...n]	CO: Technology controller fixed value 12 / Tec_ctr fix val 12		
	Access level: 2	Calculated: -	Data type: FloatingPoint32
	Can be changed: U, T	Scaling: PERCENT	Dyn. index: DDS, p0180
	Unit group: 9_1	Unit selection: p0595	Func. diagram: 7950
	Min	Max	Factory setting
	-200.00 [%]	200.00 [%]	120.00 [%]
Description:	Sets the value for fixed value 12 of the technology controller.		
Dependency:	Refer to: p2220, p2221, p2222, p2223, r2224, r2229		
Notice:	A BICO interconnection to a parameter that belongs to a drive data set always acts on the effective data set.		
p2213[0...n]	CO: Technology controller fixed value 13 / Tec_ctr fix val 13		
	Access level: 2	Calculated: -	Data type: FloatingPoint32
	Can be changed: U, T	Scaling: PERCENT	Dyn. index: DDS, p0180
	Unit group: 9_1	Unit selection: p0595	Func. diagram: 7950
	Min	Max	Factory setting
	-200.00 [%]	200.00 [%]	130.00 [%]
Description:	Sets the value for fixed value 13 of the technology controller.		
Dependency:	Refer to: p2220, p2221, p2222, p2223, r2224, r2229		
Notice:	A BICO interconnection to a parameter that belongs to a drive data set always acts on the effective data set.		
p2214[0...n]	CO: Technology controller fixed value 14 / Tec_ctr fix val 14		
	Access level: 2	Calculated: -	Data type: FloatingPoint32
	Can be changed: U, T	Scaling: PERCENT	Dyn. index: DDS, p0180
	Unit group: 9_1	Unit selection: p0595	Func. diagram: 7950
	Min	Max	Factory setting
	-200.00 [%]	200.00 [%]	140.00 [%]
Description:	Sets the value for fixed value 14 of the technology controller.		
Dependency:	Refer to: p2220, p2221, p2222, p2223, r2224, r2229		
Notice:	A BICO interconnection to a parameter that belongs to a drive data set always acts on the effective data set.		
p2215[0...n]	CO: Technology controller fixed value 15 / Tec_ctr fix val 15		
	Access level: 2	Calculated: -	Data type: FloatingPoint32
	Can be changed: U, T	Scaling: PERCENT	Dyn. index: DDS, p0180
	Unit group: 9_1	Unit selection: p0595	Func. diagram: 7950
	Min	Max	Factory setting
	-200.00 [%]	200.00 [%]	150.00 [%]
Description:	Sets the value for fixed value 15 of the technology controller.		
Dependency:	Refer to: p2220, p2221, p2222, p2223, r2224, r2229		
Notice:	A BICO interconnection to a parameter that belongs to a drive data set always acts on the effective data set.		

p2216[0...n]	Technology controller fixed value selection method / Tec_ctr FixVal sel		
	Access level: 2	Calculated: -	Data type: Integer16
	Can be changed: T	Scaling: -	Dyn. index: DDS, p0180
	Unit group: -	Unit selection: -	Func. diagram: 7950, 7951
	Min	Max	Factory setting
	1	2	1
Description:	Sets the method to select the fixed setpoints.		
Value:	1: Direct selection 2: Binary selection		
p2220[0...n]	BI: Technology controller fixed value selection bit 0 / Tec_ctrl sel bit 0		
	Access level: 3	Calculated: -	Data type: U32 / Binary
	Can be changed: T	Scaling: -	Dyn. index: CDS, p0170
	Unit group: -	Unit selection: -	Func. diagram: 7950, 7951
	Min	Max	Factory setting
	-	-	0
Description:	Sets the signal source to select a fixed value of the technology controller.		
Dependency:	Refer to: p2221, p2222, p2223		
p2221[0...n]	BI: Technology controller fixed value selection bit 1 / Tec_ctrl sel bit 1		
	Access level: 3	Calculated: -	Data type: U32 / Binary
	Can be changed: T	Scaling: -	Dyn. index: CDS, p0170
	Unit group: -	Unit selection: -	Func. diagram: 7950, 7951
	Min	Max	Factory setting
	-	-	0
Description:	Sets the signal source to select a fixed value of the technology controller.		
Dependency:	Refer to: p2220, p2222, p2223		
p2222[0...n]	BI: Technology controller fixed value selection bit 2 / Tec_ctrl sel bit 2		
	Access level: 3	Calculated: -	Data type: U32 / Binary
	Can be changed: T	Scaling: -	Dyn. index: CDS, p0170
	Unit group: -	Unit selection: -	Func. diagram: 7950, 7951
	Min	Max	Factory setting
	-	-	0
Description:	Sets the signal source to select a fixed value of the technology controller.		
Dependency:	Refer to: p2220, p2221, p2223		
p2223[0...n]	BI: Technology controller fixed value selection bit 3 / Tec_ctrl sel bit 3		
	Access level: 3	Calculated: -	Data type: U32 / Binary
	Can be changed: T	Scaling: -	Dyn. index: CDS, p0170
	Unit group: -	Unit selection: -	Func. diagram: 7950, 7951
	Min	Max	Factory setting
	-	-	0
Description:	Sets the signal source to select a fixed value of the technology controller.		
Dependency:	Refer to: p2220, p2221, p2222		

r2224	CO: Technology controller fixed value effective / Tec_ctr FixVal eff				
	Access level: 3	Calculated: -	Data type: FloatingPoint32		
	Can be changed: -	Scaling: PERCENT	Dyn. index: -		
	Unit group: 9_1	Unit selection: p0595	Func. diagram: 7950, 7951		
	Min	Max	Factory setting		
	- [%]	- [%]	- [%]		
Description:	Display and connector output for the selected and active fixed value of the technology controller.				
Dependency:	Refer to: r2229				
r2225.0	CO/BO: Technology controller fixed value selection status word / Tec_ctr FixVal ZSW				
	Access level: 3	Calculated: -	Data type: Unsigned16		
	Can be changed: -	Scaling: -	Dyn. index: -		
	Unit group: -	Unit selection: -	Func. diagram: -		
	Min	Max	Factory setting		
	-	-	-		
Description:	Display and BICO output for the status word of the fixed value selection of the technology controller.				
Bit field:	Bit	Signal name	1 signal	0 signal	FP
	00	Technology controller fixed value selected	Yes	No	7950, 7951
r2229	Technology controller number actual / Tec_ctrl No. act				
	Access level: 3	Calculated: -	Data type: Unsigned32		
	Can be changed: -	Scaling: -	Dyn. index: -		
	Unit group: -	Unit selection: -	Func. diagram: 7950		
	Min	Max	Factory setting		
	-	-	-		
Description:	Displays the number of the selected fixed setpoint of the technology controller.				
Dependency:	Refer to: r2224				
p2230[0...n]	Technology controller motorized potentiometer configuration / Tec_ctr mop config				
	Access level: 3	Calculated: -	Data type: Unsigned32		
	Can be changed: U, T	Scaling: -	Dyn. index: DDS, p0180		
	Unit group: -	Unit selection: -	Func. diagram: 7954		
	Min	Max	Factory setting		
	-	-	0000 0100 bin		
Description:	Sets the configuration for the motorized potentiometer of the technology controller.				
Bit field:	Bit	Signal name	1 signal	0 signal	FP
	00	Data save active	Yes	No	-
	02	Initial rounding-off active	Yes	No	-
	03	Non-volatile data save active for p2230.0 = 1	Yes	No	-
	04	Ramp-function generator always active	Yes	No	-
Dependency:	Refer to: r2231, p2240				

Note:

For bit 00:
 0: The setpoint for the motorized potentiometer is not saved and after ON is entered using p2240.
 1: The setpoint for the motorized potentiometer is saved and after ON is entered using r2231. In order to save in a non-volatile fashion, bit 03 should be set to 1.

For bit 02:
 0: Without initial rounding-off
 1: With initial rounding-off.

The selected ramp-up/down time is correspondingly exceeded. The initial rounding-off is a sensitive way of specifying small changes (progressive reaction when keys are pressed). The jerk for initial rounding is independent of the ramp-up time and only depends on the selected maximum value (p2237).
 It is calculated as follows:

$$r = 0.0001 \times \max(p2237, |p2238|) [\%] / 0.13^2 [s^2]$$
 The jerk is effective until the maximum acceleration is reached ($a_{max} = p2237 [\%] / p2247 [s]$ or $a_{max} = p2238 [\%] / p2248 [s]$), after which the drive continues to run linearly with constant acceleration.
 The higher the maximum acceleration (the lower that p2247 is), the longer the ramp-up time increases with respect to the set ramp-up time.

For bit 03:
 0: Non-volatile data save deactivated.
 1. The setpoint for the motorized potentiometer is saved in a non-volatile fashion (for p2230.0 = 1).

For bit 04:
 When the bit is set, the ramp-function generator is computed independent of the pulse enable. The actual output value of the motorized potentiometer is always in r2250.

r2231	Technology controller motorized potentiometer setpoint memory / Tec_ctrl mop mem		
	Access level: 3	Calculated: -	Data type: FloatingPoint32
	Can be changed: -	Scaling: -	Dyn. index: -
	Unit group: 9_1	Unit selection: p0595	Func. diagram: 7954
	Min	Max	Factory setting
	- [%]	- [%]	- [%]
Description:	Displays the setpoint memory for the motorized potentiometer of the technology controller. For p2230.0 = 1, the last setpoint that was saved is entered after ON.		
Dependency:	Refer to: p2230		

p2235[0...n]	BI: Technology controller motorized potentiometer raise setpoint / Tec_ctrl mop raise		
	Access level: 3	Calculated: -	Data type: U32 / Binary
	Can be changed: T	Scaling: -	Dyn. index: CDS, p0170
	Unit group: -	Unit selection: -	Func. diagram: 7954
	Min	Max	Factory setting
	-	-	0
Description:	Sets the signal source to continually increase the setpoint for the motorized potentiometer of the technology controller. The setpoint change (CO: r2250) depends on the set ramp-up time (p2247) and the duration of the signal that is present (BI: p2235).		
Dependency:	Refer to: p2236		

p2236[0...n]	BI: Technology controller motorized potentiometer lower setpoint / Tec_ctrl mop lower		
	Access level: 3	Calculated: -	Data type: U32 / Binary
	Can be changed: T	Scaling: -	Dyn. index: CDS, p0170
	Unit group: -	Unit selection: -	Func. diagram: 7954
	Min	Max	Factory setting
	-	-	0
Description:	Sets the signal source to continually reduce the setpoint for the motorized potentiometer of the technology controller. The setpoint change (CO: r2250) depends on the set ramp-down time (p2248) and the duration of the signal that is present (BI: p2236).		

2 Parameters

2.2 List of parameters

Dependency: Refer to: p2235

p2237[0...n] Technology controller motorized potentiometer maximum value / Tec_ctrl mop max

Access level: 3	Calculated: -	Data type: FloatingPoint32
Can be changed: U, T	Scaling: -	Dyn. index: DDS, p0180
Unit group: 9_1	Unit selection: p0595	Func. diagram: 7954
Min	Max	Factory setting
-200.00 [%]	200.00 [%]	100.00 [%]

Description: Sets the maximum value for the motorized potentiometer of the technology controller.

Dependency: Refer to: p2238

p2238[0...n] Technology controller motorized potentiometer minimum value / Tec_ctrl mop min

Access level: 2	Calculated: -	Data type: FloatingPoint32
Can be changed: U, T	Scaling: -	Dyn. index: DDS, p0180
Unit group: 9_1	Unit selection: p0595	Func. diagram: 7954
Min	Max	Factory setting
-200.00 [%]	200.00 [%]	-100.00 [%]

Description: Sets the minimum value for the motorized potentiometer of the technology controller.

Dependency: Refer to: p2237

p2240[0...n] Technology controller motorized potentiometer starting value / Tec_ctrl mop start

Access level: 2	Calculated: -	Data type: FloatingPoint32
Can be changed: U, T	Scaling: -	Dyn. index: DDS, p0180
Unit group: 9_1	Unit selection: p0595	Func. diagram: 7954
Min	Max	Factory setting
-200.00 [%]	200.00 [%]	0.00 [%]

Description: Sets the starting value for the motorized potentiometer of the technology controller.
For p2230.0 = 0, this setpoint is entered after ON.

Dependency: Refer to: p2230

r2245 CO: Technology controller mot. potentiometer setpoint before RFG / Tec_ctr mop befRFG

Access level: 2	Calculated: -	Data type: FloatingPoint32
Can be changed: -	Scaling: PERCENT	Dyn. index: -
Unit group: 9_1	Unit selection: p0595	Func. diagram: 7954
Min	Max	Factory setting
- [%]	- [%]	- [%]

Description: Displays the effective setpoint in front of the internal motorized potentiometer ramp-function generator of the technology controller.

Dependency: Refer to: r2250

p2247[0...n] Technology controller motorized potentiometer ramp-up time / Tec_ctr mop t_r-up

Access level: 2	Calculated: -	Data type: FloatingPoint32
Can be changed: U, T	Scaling: -	Dyn. index: DDS, p0180
Unit group: -	Unit selection: -	Func. diagram: 7954
Min	Max	Factory setting
0.0 [s]	1000.0 [s]	10.0 [s]

Description: Sets the ramp-up time for the internal ramp-function generator for the motorized potentiometer of the technology controller.

Dependency: Refer to: p2248

Note: The time is referred to 100 %.
When the initial rounding-off is activated (p2230.2 = 1) the ramp-up is correspondingly extended.

p2248[0...n]	Technology controller motorized potentiometer ramp-down time / Tec_ctrMop t_rdown				
	Access level: 2	Calculated: -	Data type: FloatingPoint32		
	Can be changed: U, T	Scaling: -	Dyn. index: DDS, p0180		
	Unit group: -	Unit selection: -	Func. diagram: 7954		
	Min	Max	Factory setting		
	0.0 [s]	1000.0 [s]	10.0 [s]		
Description:	Sets the ramp-down time for the internal ramp-function generator for the motorized potentiometer of the technology controller.				
Dependency:	Refer to: p2247				
Note:	The time is referred to 100 %. When the initial rounding-off is activated (p2230.2 = 1) the ramp-down is correspondingly extended.				
r2250	CO: Technology controller motorized potentiometer setpoint after RFG / Tec_ctr mop aftRFG				
	Access level: 2	Calculated: -	Data type: FloatingPoint32		
	Can be changed: -	Scaling: PERCENT	Dyn. index: -		
	Unit group: 9_1	Unit selection: p0595	Func. diagram: 7954		
	Min	Max	Factory setting		
	- [%]	- [%]	- [%]		
Description:	Displays the effective setpoint after the internal ramp-function generator for the motorized potentiometer of the technology controller.				
Dependency:	Refer to: r2245				
p2251	Technology controller mode / Tec_ctrl mode				
	Access level: 3	Calculated: -	Data type: Integer16		
	Can be changed: T	Scaling: -	Dyn. index: -		
	Unit group: -	Unit selection: -	Func. diagram: 7958		
	Min	Max	Factory setting		
	0	1	0		
Description:	Sets the mode for using the technology controller output.				
Value:	0: Technology controller as main speed setpoint 1: Technology controller as supplementary speed setpoint				
Dependency:	p2251 = 0, 1 is only effective if the enable signal of the technology controller is interconnected (p2200 > 0).				
p2252	Technology controller configuration / Tec_ctrl config				
	Access level: 3	Calculated: p0340 = 1	Data type: Unsigned16		
	Can be changed: U, T	Scaling: -	Dyn. index: -		
	Unit group: -	Unit selection: -	Func. diagram: -		
	Min	Max	Factory setting		
	-	-	0000 0000 bin		
Description:	Sets the configuration of the technology controller.				
Bit field:	Bit	Signal name	1 signal	0 signal	FP
	04	Ramp-up/ramp-down function generator bypass	Deactivated	Activated	-
	05	Integrator active for skip speeds	Yes	No	-
	06	Internal controller limit not displayed	Yes	No	-
Dependency:	For bit 04 = 0: The setting is only effective when the PID controller is deactivated. Refer to: p2280, p2285 For bit 04 = 1 (p2251 = 0): The PID controller can oscillate if the ramp-up and ramp-down times of the speed setpoint channel are not taken into account when setting controller parameters p2280 and p2285.				
Caution:					

Note: For bit 04 = 0 (only for p2251 = 0):
 The ramp-function generator in the speed setpoint channel is bypassed when the technology controller is operational.
 As a consequence, ramp times p1120, p1121 are not taken into consideration when configuring the controller.
 For bit 04 = 1 (only for p2251 = 0):
 The ramp-function generator in the speed setpoint channel is not bypassed when the technology controller is operational.
 As a consequence, the ramp-up and ramp-down times (p1120, p1121) remain effective, and must be taken into account as controlled system variables when setting the PID controller parameters (p2280, p2285).
 The enable ramps of the PID controller are ensured in this setting by p1120, p1121 as well as rounding functions p1130 and p1131. The ramp-up/ramp-down time of the PID controller limiting p2293 must be set appropriately shorter, as otherwise this has an impact on the speed setpoint channel.
 For bit 05 = 0:
 The integral component of the PID controller is held if a skip band or the minimum speed range is passed through in the speed set point channel.
 This prevents the speed from oscillating between the edges of the skip band.
 For bit 05 = 1:
 The setting is only effective if a skip band is no longer active.
 The integral component of the PID controller is not held in the range of the skip speeds.
 The skip band is passed through even for small system deviations and low controller gain factors. In so doing, the controller integral time must be selected large enough so that no undesirable speed oscillations occur between the skip band edges.
 The influence of a minimum speed p1080 on the integration behavior can be reduced by raising the lower PID controller limit to $p1080 / p2000 * 100\%$.
 For bit 06 = 1:
 In r2349, bit 10 and bit 11 are not displayed when reaching internal limits (e.g. for OFF1/3).

p2253[0...n]	CI: Technology controller setpoint 1 / Tec_ctrl setp 1		
	Access level: 2	Calculated: -	Data type: U32 / FloatingPoint32
	Can be changed: U, T	Scaling: PERCENT	Dyn. index: CDS, p0170
	Unit group: -	Unit selection: -	Func. diagram: 7958
	Min	Max	Factory setting
	-	-	0
Description:	Sets the signal source for the setpoint 1 of the technology controller.		
Dependency:	Refer to: p2254, p2255		

p2254[0...n]	CI: Technology controller setpoint 2 / Tec_ctrl setp 2		
	Access level: 3	Calculated: -	Data type: U32 / FloatingPoint32
	Can be changed: U, T	Scaling: PERCENT	Dyn. index: CDS, p0170
	Unit group: -	Unit selection: -	Func. diagram: 7958
	Min	Max	Factory setting
	-	-	0
Description:	Sets the signal source for the setpoint 2 of the technology controller.		
Dependency:	Refer to: p2253, p2256		

p2255	Technology controller setpoint 1 scaling / Tec_ctrl set1 scal		
	Access level: 3	Calculated: -	Data type: FloatingPoint32
	Can be changed: U, T	Scaling: -	Dyn. index: -
	Unit group: -	Unit selection: -	Func. diagram: 7958
	Min	Max	Factory setting
	0.00 [%]	100.00 [%]	100.00 [%]
Description:	Sets the scaling for the setpoint 1 of the technology controller.		
Dependency:	Refer to: p2253		

p2256	Technology controller setpoint 2 scaling / Tec_ctrl set2 scal	Access level: 3	Calculated: -	Data type: FloatingPoint32
		Can be changed: U, T	Scaling: -	Dyn. index: -
		Unit group: -	Unit selection: -	Func. diagram: 7958
		Min	Max	Factory setting
		0.00 [%]	100.00 [%]	100.00 [%]
Description:	Sets the scaling for the setpoint 2 of the technology controller.			
Dependency:	Refer to: p2254			
p2257	Technology controller ramp-up time / Tec_ctrl t_ramp-up	Access level: 2	Calculated: -	Data type: FloatingPoint32
		Can be changed: U, T	Scaling: -	Dyn. index: -
		Unit group: -	Unit selection: -	Func. diagram: 7958
		Min	Max	Factory setting
		0.00 [s]	650.00 [s]	1.00 [s]
Description:	Sets the ramp-up time of the technology controller.			
Dependency:	Refer to: p2258			
Note:	The ramp-up time is referred to 100 %.			
p2258	Technology controller ramp-down time / Tec_ctrl t_ramp-dn	Access level: 2	Calculated: -	Data type: FloatingPoint32
		Can be changed: U, T	Scaling: -	Dyn. index: -
		Unit group: -	Unit selection: -	Func. diagram: 7958
		Min	Max	Factory setting
		0.00 [s]	650.00 [s]	1.00 [s]
Description:	Sets the ramp-down time of the technology controller.			
Dependency:	Refer to: p2257			
Note:	The ramp-down time is referred to 100 %.			
r2260	CO: Technology controller setpoint after ramp-function generator / Tec_ctr set aftRFG	Access level: 2	Calculated: -	Data type: FloatingPoint32
		Can be changed: -	Scaling: PERCENT	Dyn. index: -
		Unit group: 9_1	Unit selection: p0595	Func. diagram: 7958
		Min	Max	Factory setting
		- [%]	- [%]	- [%]
Description:	Displays the setpoint after the ramp-function generator of the technology controller.			
p2261	Technology controller setpoint filter time constant / Tec_ctrl set T	Access level: 3	Calculated: -	Data type: FloatingPoint32
		Can be changed: U, T	Scaling: -	Dyn. index: -
		Unit group: -	Unit selection: -	Func. diagram: 7958
		Min	Max	Factory setting
		0.000 [s]	60.000 [s]	0.000 [s]
Description:	Sets the time constant for the setpoint filter (PT1) of the technology controller.			

r2262	CO: Technology controller setpoint after filter / Tec_ctrl set aftFlt		
	Access level: 4	Calculated: -	Data type: FloatingPoint32
	Can be changed: -	Scaling: PERCENT	Dyn. index: -
	Unit group: 9_1	Unit selection: p0595	Func. diagram: 7958
	Min	Max	Factory setting
	- [%]	- [%]	- [%]
Description:	Display and connector output for the smoothed setpoint after the setpoint filter (PT1) of the technology controller.		
p2263	Technology controller type / Tec_ctrl type		
	Access level: 3	Calculated: -	Data type: Integer16
	Can be changed: T	Scaling: -	Dyn. index: -
	Unit group: -	Unit selection: -	Func. diagram: 7958
	Min	Max	Factory setting
	0	1	0
Description:	Sets the type of technology controller.		
Value:	0: D component in the actual value signal 1: D component in system deviation		
p2264[0...n]	CI: Technology controller actual value / Tec_ctrl act val		
	Access level: 2	Calculated: -	Data type: U32 / FloatingPoint32
	Can be changed: U, T	Scaling: PERCENT	Dyn. index: CDS, p0170
	Unit group: -	Unit selection: -	Func. diagram: 7958
	Min	Max	Factory setting
	-	-	0
Description:	Sets the signal source for the actual value of the technology controller.		
p2265	Technology controller actual value filter time constant / Tec_ctrl act T		
	Access level: 2	Calculated: -	Data type: FloatingPoint32
	Can be changed: U, T	Scaling: -	Dyn. index: -
	Unit group: -	Unit selection: -	Func. diagram: 7958
	Min	Max	Factory setting
	0.000 [s]	60.000 [s]	0.000 [s]
Description:	Sets the time constant for the actual value filter (PT1) of the technology controller.		
r2266	CO: Technology controller actual value after filter / Tec_ctrl act aftFlt		
	Access level: 3	Calculated: -	Data type: FloatingPoint32
	Can be changed: -	Scaling: PERCENT	Dyn. index: -
	Unit group: 9_1	Unit selection: p0595	Func. diagram: 7958
	Min	Max	Factory setting
	- [%]	- [%]	- [%]
Description:	Display and connector output for the smoothed actual value after the filter (PT1) of the technology controller.		
p2267	Technology controller upper limit actual value / Tec_ctrl u_lim act		
	Access level: 3	Calculated: -	Data type: FloatingPoint32
	Can be changed: U, T	Scaling: PERCENT	Dyn. index: -
	Unit group: 9_1	Unit selection: p0595	Func. diagram: 7958
	Min	Max	Factory setting
	-200.00 [%]	200.00 [%]	100.00 [%]
Description:	Sets the upper limit for the actual value signal of the technology controller.		
Dependency:	Refer to: p2264, p2265, p2271 Refer to: F07426		
Notice:	If the actual value exceeds this upper limit, this results in fault F07426.		

p2268	Technology controller lower limit actual value / Tec_ctrl l_lim act		
	Access level: 3	Calculated: -	Data type: FloatingPoint32
	Can be changed: U, T	Scaling: PERCENT	Dyn. index: -
	Unit group: 9_1	Unit selection: p0595	Func. diagram: 7958
	Min	Max	Factory setting
	-200.00 [%]	200.00 [%]	-100.00 [%]
Description:	Sets the lower limit for the actual value signal of the technology controller.		
Dependency:	Refer to: p2264, p2265, p2271 Refer to: F07426		
Notice:	If the actual value falls below this lower limit, this results in fault F07426.		
p2269	Technology controller gain actual value / Tech_ctrl gain act		
	Access level: 3	Calculated: -	Data type: FloatingPoint32
	Can be changed: U, T	Scaling: -	Dyn. index: -
	Unit group: -	Unit selection: -	Func. diagram: 7958
	Min	Max	Factory setting
	0.00 [%]	500.00 [%]	100.00 [%]
Description:	Sets the scaling factor for the actual value of the technology controller.		
Dependency:	Refer to: p2264, p2265, p2267, p2268, p2271		
Note:	For 100%, the actual value is not changed.		
p2270	Technology controller actual value function / Tec_ctr ActVal fct		
	Access level: 3	Calculated: -	Data type: Integer16
	Can be changed: U, T	Scaling: -	Dyn. index: -
	Unit group: -	Unit selection: -	Func. diagram: 7958
	Min	Max	Factory setting
	0	3	0
Description:	Setting to use an arithmetic function for the actual value signal of the technology controller.		
Value:	0: Output (y) = input (x) 1: Root function (root from x) 2: Square function (x * x) 3: Cube function (x * x * x)		
Dependency:	Refer to: p2264, p2265, p2267, p2268, p2269, p2271		
p2271	Technology controller actual value inversion (sensor type) / Tech_ctrl act inv		
	Access level: 3	Calculated: -	Data type: Integer16
	Can be changed: T	Scaling: -	Dyn. index: -
	Unit group: -	Unit selection: -	Func. diagram: 7958
	Min	Max	Factory setting
	0	1	0
Description:	Setting to invert the actual value signal of the technology controller. The inversion depends on the sensor type for the actual value signal.		
Value:	0: No inversion 1: Inversion actual value signal		
Caution:	If the actual value inversion is incorrectly selected, then the closed-loop control with the technology controller can become unstable and can oscillate!		
			
Note:	The correct setting can be determined as follows: - inhibit the technology controller (p2200 = 0). - increase the motor speed and in so doing, measure the actual value signal of the technology controller. --> If the actual value increases as the motor speed increases, then p2271 should be set to 0 (no inversion). --> If the actual value decreases as the motor speed increases, then p2271 should be set to 1 (the actual value signal is inverted).		

r2272	CO: Technology controller actual value scaled / Tech_ctrl act scal		
	Access level: 2	Calculated: -	Data type: FloatingPoint32
	Can be changed: -	Scaling: PERCENT	Dyn. index: -
	Unit group: 9_1	Unit selection: p0595	Func. diagram: 7958
	Min	Max	Factory setting
	- [%]	- [%]	- [%]
Description:	Display and connector output for the scaled actual value signal of the technology controller.		
Dependency:	Refer to: p2264, p2265, r2266, p2267, p2268, p2269, p2270, p2271		
r2273	CO: Technology controller system deviation / Tec_ctrl sys_dev		
	Access level: 2	Calculated: -	Data type: FloatingPoint32
	Can be changed: -	Scaling: PERCENT	Dyn. index: -
	Unit group: 9_1	Unit selection: p0595	Func. diagram: 7958
	Min	Max	Factory setting
	- [%]	- [%]	- [%]
Description:	Displays the system deviation between the setpoint and actual value of the technology controller.		
Dependency:	Refer to: p2263		
p2274	Technology controller differentiation time constant / Tec_ctrl D comp T		
	Access level: 2	Calculated: -	Data type: FloatingPoint32
	Can be changed: U, T	Scaling: -	Dyn. index: -
	Unit group: -	Unit selection: -	Func. diagram: 7958
	Min	Max	Factory setting
	0.000 [s]	60.000 [s]	0.000 [s]
Description:	Sets the time constant for the differentiation (D component) of the technology controller.		
Note:	p2274 = 0: Differentiation is disabled.		
p2280	Technology controller proportional gain / Tec_ctrl Kp		
	Access level: 2	Calculated: -	Data type: FloatingPoint32
	Can be changed: U, T	Scaling: -	Dyn. index: -
	Unit group: -	Unit selection: -	Func. diagram: 7958
	Min	Max	Factory setting
	0.000	1000.000	1.000
Description:	Sets the proportional gain (P component) of the technology controller.		
Note:	p2280 = 0: The proportional gain is disabled.		
p2285	Technology controller integral time / Tec_ctrl Tn		
	Access level: 2	Calculated: -	Data type: FloatingPoint32
	Can be changed: U, T	Scaling: -	Dyn. index: -
	Unit group: -	Unit selection: -	Func. diagram: 7958
	Min	Max	Factory setting
	0.000 [s]	10000.000 [s]	30.000 [s]
Description:	Sets the integral time (I component, integrating time constant) of the technology controller.		
Notice:	The following applies for p2251 = 0: If the output of the technology controller lies within the range of a suppression (skip) bandwidth (p1091 ... p1094, p1101) or below the minimum speed (p1080), the integral component of the controller is held so that the controller temporarily works as a P controller. This is necessary in order to prevent the controller from behaving in an unstable manner, as the ramp-function generator switches to the parameterized up and down ramps (p1120, p1121) at the same time in order to avoid setpoint steps. This state can be exited or avoided by changing the controller setpoint or by using the start speed (= minimum speed).		
Note:	When the controller output reaches the limit, the I component of the controller is held. p2285 = 0: The integral time is disabled and the I component of the controller is reset.		

p2286[0...n]	BI: Hold technology controller integrator / Tec_ctr integ hold		
Access level: 3	Calculated: -	Data type: U32 / Binary	
Can be changed: T	Scaling: -	Dyn. index: CDS, p0170	
Unit group: -	Unit selection: -	Func. diagram: 7958	
Min	Max	Factory setting	
-	-	56.13	
Description:	Sets the signal source to hold the integrator for the technology controller.		

p2289[0...n]	CI: Technology controller precontrol signal / Tec_ctr prectr_sig		
Access level: 3	Calculated: -	Data type: U32 / FloatingPoint32	
Can be changed: U, T	Scaling: PERCENT	Dyn. index: CDS, p0170	
Unit group: -	Unit selection: -	Func. diagram: 7958	
Min	Max	Factory setting	
-	-	0	
Description:	Sets the signal source for the precontrol signal of the technology controller.		

p2290[0...n]	BI: Technology controller limiting enable / Tec_ctrl lim enab		
Access level: 2	Calculated: -	Data type: U32 / Binary	
Can be changed: T	Scaling: -	Dyn. index: CDS, p0170	
Unit group: -	Unit selection: -	Func. diagram: 7958	
Min	Max	Factory setting	
-	-	1	
Description:	Sets the signal source to enable the technology controller output. The technology controller output is enabled with a 1 signal. The technology controller output is held with a 0 signal.		

p2291	CO: Technology controller maximum limiting / Tec_ctrl max_lim		
Access level: 3	Calculated: -	Data type: FloatingPoint32	
Can be changed: U, T	Scaling: PERCENT	Dyn. index: -	
Unit group: -	Unit selection: -	Func. diagram: 7958	
Min	Max	Factory setting	
-200.00 [%]	200.00 [%]	100.00 [%]	
Description:	Sets the maximum limit of the technology controller.		
Dependency:	Refer to: p2292		
Caution:	The maximum limit must always be greater than the minimum limit (p2291 > p2292).		



p2292	CO: Technology controller minimum limiting / Tec_ctrl min_lim		
Access level: 3	Calculated: -	Data type: FloatingPoint32	
Can be changed: U, T	Scaling: PERCENT	Dyn. index: -	
Unit group: -	Unit selection: -	Func. diagram: 7958	
Min	Max	Factory setting	
-200.00 [%]	200.00 [%]	0.00 [%]	
Description:	Sets the minimum limit of the technology controller.		
Dependency:	Refer to: p2291		
Caution:	The maximum limit must always be greater than the minimum limit (p2291 > p2292).		



p2293	Technology controller ramp-up/ramp-down time / Tec_ctrl t_RU/RD	Access level: 3	Calculated: -	Data type: FloatingPoint32
		Can be changed: U, T	Scaling: -	Dyn. index: -
		Unit group: -	Unit selection: -	Func. diagram: 7958
		Min	Max	Factory setting
		0.00 [s]	100.00 [s]	1.00 [s]
Description:	Sets the ramping time for the output signal of the technology controller.			
Dependency:	Refer to: p2291, p2292			
Note:	The time refers to the set maximum and minimum limits (p2291, p2292).			
r2294	CO: Technology controller output signal / Tec_ctrl outp_sig	Access level: 2	Calculated: -	Data type: FloatingPoint32
		Can be changed: -	Scaling: PERCENT	Dyn. index: -
		Unit group: -	Unit selection: -	Func. diagram: 7958
		Min	Max	Factory setting
		- [%]	- [%]	- [%]
Description:	Display and connector output for the output signal of the technology controller.			
Dependency:	Refer to: p2295			
p2295	CO: Technology controller output scaling / Tec_ctrl outp_scal	Access level: 3	Calculated: -	Data type: FloatingPoint32
		Can be changed: U, T	Scaling: PERCENT	Dyn. index: -
		Unit group: -	Unit selection: -	Func. diagram: 7958
		Min	Max	Factory setting
		-100.00 [%]	100.00 [%]	100.00 [%]
Description:	Sets the scaling for the output signal of the technology controller.			
p2296[0...n]	CI: Technology controller output scaling / Tec_ctrl outp_scal	Access level: 3	Calculated: -	Data type: U32 / FloatingPoint32
		Can be changed: U, T	Scaling: PERCENT	Dyn. index: CDS, p0170
		Unit group: -	Unit selection: -	Func. diagram: 7958
		Min	Max	Factory setting
		-	-	2295[0]
Description:	Sets the signal source for the scaling value of the technology controller.			
Dependency:	Refer to: p2295			
p2297[0...n]	CI: Technology controller maximum limit signal source / Tec_ctrlMaxLim s_s	Access level: 3	Calculated: -	Data type: U32 / FloatingPoint32
		Can be changed: U, T	Scaling: PERCENT	Dyn. index: CDS, p0170
		Unit group: -	Unit selection: -	Func. diagram: 7958
		Min	Max	Factory setting
		-	-	1084[0]
Description:	Sets the signal source for the maximum limiting of the technology controller.			
Dependency:	Refer to: p2291			
Note:	In order that the output of the technology controller does not exceed the maximum speed limit, its upper limit p2297 should be connected to the actual maximum speed r1084. In mode p2251 = 1, p2299 must also be connected to the output of the ramp-function generator r1150.			

p2298[0...n]	CI: Technology controller minimum limit signal source / Tec_ctrl min_l s_s		
	Access level: 3	Calculated: -	Data type: U32 / FloatingPoint32
	Can be changed: U, T	Scaling: PERCENT	Dyn. index: CDS, p0170
	Unit group: -	Unit selection: -	Func. diagram: 7958
	Min	Max	Factory setting
	-	-	1087[0]
Description:	Sets the signal source for the minimum limiting of the technology controller.		
Dependency:	Refer to: p2292		
Note:	If the technology controller is rotated in a negative direction in mode p2251 = 0, its lower limit p2298 should be connected to the actual minimum speed r1087. In mode p2251 = 1, p2299 must also be connected to the output of the ramp-function generator r1150.		
p2299[0...n]	CI: Technology controller limit offset / Tech_ctrl lim offs		
	Access level: 3	Calculated: -	Data type: U32 / FloatingPoint32
	Can be changed: U, T	Scaling: PERCENT	Dyn. index: CDS, p0170
	Unit group: -	Unit selection: -	Func. diagram: 7958
	Min	Max	Factory setting
	-	-	0
Description:	Sets the signal source for the offset of the output limiting of the technology controller.		
Note:	In mode p2251 = 1, p2299 must be connected to the output of ramp-function generator r1150 so that the technology controller stops when the speed limits are reached (see also p2297, p2298).		
p2302	Technology controller output signal starting value / Tec_ctr start val		
	Access level: 3	Calculated: -	Data type: FloatingPoint32
	Can be changed: U, T	Scaling: -	Dyn. index: -
	Unit group: -	Unit selection: -	Func. diagram: 7958
	Min	Max	Factory setting
	0.00 [%]	200.00 [%]	0.00 [%]
Description:	Sets the start value for the output of the technology controller. If the drive is switched on and the technology controller is already enabled (see p2200, r0056.3), then its output signal r2294 first goes to the start value p2302, before the controller starts to operate.		
Dependency:	The starting value is only effective in the mode "technology controller as main speed setpoint" (p2251 = 0). If the technology controller is first enabled when the drive is switched on, a start speed remains ineffective, and the controller output starts with the actual setpoint speed of the ramp-function generator.		
Note:	If the technology controller operates on the speed/setpoint channel (p2251 = 0), then the starting value is interpreted as the starting speed and when operation is enabled, is connected to the output of the technology controller (r2294). If fault F07426 "technology controller actual value limited" occurs while ramping up to the starting value and if the associated reaction has been set to "NONE" (see p2100, p2101), the starting value is kept as the speed setpoint instead of a switch to closed-loop control operation.		
p2306	Technology controller system deviation inversion / Tec_ctr SysDev inv		
	Access level: 3	Calculated: -	Data type: Integer16
	Can be changed: T	Scaling: -	Dyn. index: -
	Unit group: -	Unit selection: -	Func. diagram: 7958
	Min	Max	Factory setting
	0	1	0
Description:	Setting to invert the system deviation of the technology controller. The setting depends on the type of control loop.		
Value:	0: No inversion 1: Inversion		
Caution:	If the actual value inversion is incorrectly selected, then the closed-loop control with the technology controller can become unstable and can oscillate!		
			

2 Parameters

2.2 List of parameters

Note: The correct setting can be determined as follows:

- inhibit the technology controller (p2200 = 0).
- increase the motor speed and in so doing, measure the actual value signal (of the technology controller).
- if the actual value increases with increasing motor speed, then the inversion should be switched out.
- if the actual value decreases with increasing motor speed, then the inversion should be set.

If value = 0:
The drive reduces the output speed when the actual value rises (e.g. for heating fans, intake pump, compressor).

For value = 1:
The drive increases the output speed when the actual value increases (e.g. for cooling fans, discharge pumps).

p2339	Techn. controller threshold value f. I comp. hold for skip speed / Tec_ctrl thr_skip		
	Access level: 3	Calculated: -	Data type: FloatingPoint32
	Can be changed: U, T	Scaling: PERCENT	Dyn. index: -
	Unit group: 9_1	Unit selection: p0595	Func. diagram: -
	Min	Max	Factory setting
	0.00 [%]	200.00 [%]	2.00 [%]
Description:	Sets the threshold value for the system deviation of the technology controller, which controls holding the controller integral component in the range of the skip speeds of the ramp-function generator.		
Recommendation:	To avoid speed setpoint steps in the range of the skip speeds, we recommend setting p2252 bit 4 = 1 (ramp-function generator bypass deactivated).		
Dependency:	The parameter has no effect for p2252 bit 5 = 1 (integrator hold deactivated). Refer to: r2273		
Note:	Only p2251 = 0: If the output signal of the technology controller reaches a skip band in the speed setpoint channel, then the integral component of the controller is held, if at the same time, the system deviation is lower than the threshold value set here. By holding the integral component, it can be avoided that the controller oscillates in the range of the skip bands.		

r2344	CO: Technology controller last speed setpoint (smoothed) / Tec_ctrl n_setp_sm		
	Access level: 3	Calculated: -	Data type: FloatingPoint32
	Can be changed: -	Scaling: PERCENT	Dyn. index: -
	Unit group: -	Unit selection: -	Func. diagram: 7958
	Min	Max	Factory setting
	- [%]	- [%]	- [%]
Description:	Displays the smoothed speed setpoint of the technology controller prior to switching to operation with fault response (see p2345).		
Dependency:	Refer to: p2345		
Note:	Smoothing time = 10 s		

p2345	Technology controller fault response / Tech_ctrl flt resp		
	Access level: 3	Calculated: -	Data type: Integer16
	Can be changed: U, T	Scaling: -	Dyn. index: -
	Unit group: -	Unit selection: -	Func. diagram: 7958
	Min	Max	Factory setting
	0	2	0
Description:	Sets the response of the technology controller to the occurrence of fault F07426 (technology controller actual value limited). The fault response is executed if status bit 8 or 9 in the technology controller status word r2349 is set. If both status bits are zero, a switch back to technology controller operation will follow.		
Value:	0: Function inhibited 1: On fault: Changeover to r2344 (or p2302) 2: On fault: Changeover to p2215		
Dependency:	The parameterized fault response is only effective if the technology controller mode is set to p2251 = 0 (technology controller as main setpoint). Refer to: p2267, p2268, r2344 Refer to: F07426		

- Notice:** Dependent upon the application, the changing over of the setpoint when fault F07426 occurs can lead to the fault condition disappearing and the re-activation of the technology controller. This can repeat itself and cause limit oscillations. In this case, a different fault response or a different fixed setpoint 15 for the fault response p2345 = 2 should be selected.
- Note:** The parameterized fault response can only be achieved if the default fault response of the technology controller fault F07426 is set to "NONE" (see p2100, p2101). If a fault response other than "NONE" is entered in p2101 for F07426, p2345 must be set to zero.
- If the fault occurs during ramping up to the starting setpoint p2302, this starting setpoint is retained as the final value (there is no changeover to the fault response setpoint).

r2349.0...13 CO/BO: Technology controller status word / Tec_ctrl status

Access level: 3	Calculated: -	Data type: Unsigned32
Can be changed: -	Scaling: -	Dyn. index: -
Unit group: -	Unit selection: -	Func. diagram: 7958
Min	Max	Factory setting
-	-	-

Description: Display and BICO output for the status word of the technology controller.

Bit field:	Bit	Signal name	1 signal	0 signal	FP
	00	Technology controller deactivated	Yes	No	-
	01	Technology controller limited	Yes	No	-
	02	Technology controller motorized potentiometer limited max	Yes	No	-
	03	Technology controller motorized potentiometer limited min	Yes	No	-
	04	Technology controller speed setpoint total in setpoint channel	Yes	No	-
	05	Technology controller RFG bypassed in the setpoint channel	Yes	No	-
	06	Technology controller starting value at the current limit	No	Yes	-
	07	Technology controller output negative	Yes	No	-
	08	Technology controller actual value at the minimum	Yes	No	-
	09	Technology controller actual value at the maximum	Yes	No	-
	10	Technology controller output at the minimum	Yes	No	-
	11	Technology controller output at the maximum	Yes	No	-
	12	Fault response active	Yes	No	-
	13	Technology controller limiting enable	Yes	No	-

- Note:** While the technology controller is enabled, the following applies:
When switching off with OFF1, OFF3 and for pulse inhibit, bits 10 and 11 are simultaneously set to 1 as the controller output is defined by the internal limiting.

p2900[0...n] CO: Fixed value 1 [%] / Fixed value 1 [%]

Access level: 3	Calculated: -	Data type: FloatingPoint32
Can be changed: U, T	Scaling: PERCENT	Dyn. index: DDS, p0180
Unit group: -	Unit selection: -	Func. diagram: 1021
Min	Max	Factory setting
-10000.00 [%]	10000.00 [%]	120.00 [%]

Description: Setting and connector output for a fixed percentage value.

Dependency: Refer to: p2901, r2902, p2930

Notice: A BICO interconnection to a parameter that belongs to a drive data set always acts on the effective data set.

Note: The value can be used to interconnect a scaling function (e.g. scaling the main setpoint).

p2901[0...n]	CO: Fixed value 2 [%] / Fixed value 2 [%]		
	Access level: 3	Calculated: -	Data type: FloatingPoint32
	Can be changed: U, T	Scaling: PERCENT	Dyn. index: DDS, p0180
	Unit group: -	Unit selection: -	Func. diagram: 1021
	Min	Max	Factory setting
	-10000.00 [%]	10000.00 [%]	0.00 [%]
Description:	Setting and connector output for a fixed percentage value.		
Dependency:	Refer to: p2900, p2930		
Notice:	A BICO interconnection to a parameter that belongs to a drive data set always acts on the effective data set.		
Note:	The value can be used to interconnect a scaling function (e.g. scaling of the supplementary setpoint)		
r2902[0...14]	CO: Fixed values [%] / Fixed values [%]		
	Access level: 3	Calculated: -	Data type: FloatingPoint32
	Can be changed: -	Scaling: PERCENT	Dyn. index: -
	Unit group: -	Unit selection: -	Func. diagram: 1021
	Min	Max	Factory setting
	- [%]	- [%]	- [%]
Description:	Display and connector output for frequently used percentage values.		
Index:	[0] = Fixed value +0 % [1] = Fixed value +5 % [2] = Fixed value +10 % [3] = Fixed value +20 % [4] = Fixed value +50 % [5] = Fixed value +100 % [6] = Fixed value +150 % [7] = Fixed value +200 % [8] = Fixed value -5 % [9] = Fixed value -10 % [10] = Fixed value -20 % [11] = Fixed value -50 % [12] = Fixed value -100 % [13] = Fixed value -150 % [14] = Fixed value -200 %		
Dependency:	Refer to: p2900, p2901, p2930		
Note:	The signal sources can, for example, be used to interconnect scalings.		
p2930[0...n]	CO: Fixed value M [Nm] / Fixed value M [Nm]		
	Access level: 3	Calculated: -	Data type: FloatingPoint32
	Can be changed: U, T	Scaling: p2003	Dyn. index: DDS, p0180
	Unit group: -	Unit selection: -	Func. diagram: 1021
	Min	Max	Factory setting
	-100000.00 [Nm]	100000.00 [Nm]	0.00 [Nm]
Description:	Setting and connector output for a fixed torque value.		
Dependency:	Refer to: p2900, p2901, r2902		
Notice:	A BICO interconnection to a parameter that belongs to a drive data set always acts on the effective data set.		
Note:	The value can, for example, be used to interconnect a supplementary torque.		

r2969[0...6]	Flux model value display / Psi_mod val displ		
	Access level: 3	Calculated: -	Data type: FloatingPoint32
	Can be changed: -	Scaling: -	Dyn. index: -
	Unit group: -	Unit selection: -	Func. diagram: -
	Min	Max	Factory setting
	-	-	-
Description:	<p>Displays the values of the direct access flux model for the synchronous reluctance motor (RESM) for diagnostic purposes.</p> <p>Valid values are only displayed when the pulses are inhibited.</p> <p>For index [0]: Displays the entered direct axis current id in Arms:</p> <p>For index [1, 2, 3]: Displays the saturation curves of the direct axis flux psid(id, iq):</p> <ul style="list-style-type: none"> - r2969[1]: flux in Vsrms with respect to the direct axis current for iq = 0 - r2969[2]: flux in Vsrms with respect to the direct axis current for iq = 0.5 * p2950 - r2969[3]: flux in Vsrms with respect to the direct axis current for iq = p2950 <p>For index [4, 5, 6]: Displays the relative error of the current inversion (id(psid, iq) - id) / p2950:</p> <ul style="list-style-type: none"> - r2969[4]: error with respect to direct axis current for iq = 0 - r2969[5]: error with respect to direct axis current for iq = 0.5 * p2950 - r2969[6]: error with respect to direct axis current for iq = p2950 		
Index:	<p>[0] = d-current [1] = d-flux iq0 [2] = d-flux iq1 [3] = d-flux iq2 [4] = d-current error iq0 [5] = d-current error iq1 [6] = d-current error iq2</p>		
Note:	RESM: reluctance synchronous motor (synchronous reluctance motor)		
p3110	External fault 3 switch-on delay / Ext fault 3 t_on		
	Access level: 3	Calculated: -	Data type: Unsigned16
	Can be changed: U, T	Scaling: -	Dyn. index: -
	Unit group: -	Unit selection: -	Func. diagram: 2546
	Min	Max	Factory setting
	0 [ms]	1000 [ms]	0 [ms]
Description:	Sets the delay time for external fault 3.		
Dependency:	Refer to: p2108, p3111, p3112 Refer to: F07862		
p3111[0...n]	Bl: External fault 3 enable / Ext fault 3 enab		
	Access level: 3	Calculated: -	Data type: U32 / Binary
	Can be changed: U, T	Scaling: -	Dyn. index: CDS, p0170
	Unit group: -	Unit selection: -	Func. diagram: -
	Min	Max	Factory setting
	-	-	1
Description:	<p>Sets the signal source for the enable signal of external fault 3.</p> <p>External fault 3 is initiated by the following AND logic operation:</p> <ul style="list-style-type: none"> - Bl: p2108 negated - Bl: p3111 - Bl: p3112 negated 		
Dependency:	Refer to: p2108, p3110, p3112 Refer to: F07862		

p3112[0...n]	BI: External fault 3 enable negated / Ext flt 3 enab neg		
	Access level: 3	Calculated: -	Data type: U32 / Binary
	Can be changed: U, T	Scaling: -	Dyn. index: CDS, p0170
	Unit group: -	Unit selection: -	Func. diagram: -
	Min	Max	Factory setting
	-	-	0
Description:	Sets the signal source for the negated enable signal of external fault 3. External fault 3 is initiated by the following AND logic operation: - BI: p2108 negated - BI: p3111 - BI: p3112 negated		
Dependency:	Refer to: p2108, p3110, p3111 Refer to: F07862		

r3113.0...15	CO/BO: NAMUR message bit bar / NAMUR bit bar		
	Access level: 3	Calculated: -	Data type: Unsigned16
	Can be changed: -	Scaling: -	Dyn. index: -
	Unit group: -	Unit selection: -	Func. diagram: -
	Min	Max	Factory setting
	-	-	-

Description: Display and BICO output for the status of the NAMUR message bit bar.
The faults and alarms are assigned to the appropriate signaling/message classes and influence a specific message bit.

Bit field:	Bit	Signal name	1 signal	0 signal	FP
	00	Fault converter information electronics/software error	Yes	No	-
	01	Network fault	Yes	No	-
	02	DC link overvoltage	Yes	No	-
	03	Fault drive converter power electronics	Yes	No	-
	04	Drive converter overtemperature	Yes	No	-
	05	Ground fault	Yes	No	-
	06	Motor overload	Yes	No	-
	07	Bus error	Yes	No	-
	08	External safety-relevant shutdown	Yes	No	-
	10	Error communication internal	Yes	No	-
	11	Fault infeed	Yes	No	-
	15	Other faults	Yes	No	-

Note:	<p>For bit 00: Hardware or software malfunction was identified. Carry out a POWER ON of the component involved. If it occurs again, contact Technical Support.</p> <p>For bit 01: A line supply fault has occurred (phase failure, voltage level, ...). Check the line supply / fuses. Check the supply voltage. Check the wiring.</p> <p>For bit 02: The DC link voltage has assumed an inadmissibly high value. Check the dimensioning of the system (line supply, reactor, voltages). Check the infeed settings.</p> <p>For bit 03: An inadmissible operating state of the power electronics was identified (overcurrent, overtemperature, IGBT failure, ...). Check that the permissible load cycles are maintained. Check the ambient temperatures (fan).</p> <p>For bit 04: The temperature in the component has exceeded the highest permissible limit. Check the ambient temperature / control cabinet cooling.</p> <p>For bit 05: A ground fault / inter-phase short-circuit was detected in the power cables or in the motor windings. Check the power cables (connection). Check the motor.</p> <p>For bit 06: The motor was operated outside the permissible limits (temperature, current, torque, ...). Check the load cycles and limits that have been set. Check the ambient temperature / motor cooling.</p> <p>For bit 07: The communication to the higher-level control system (internal coupling, PROFIBUS, PROFINET, ...) is faulted or interrupted. Check the state of the higher-level control system. Check the communication connection/wiring. Check the bus configuration / clock cycles.</p> <p>For bit 08: A safety operation monitoring function (Safety) has detected an error.</p> <p>For bit 09: When evaluating the encoder signals (track signals, zero marks, absolute values, ...) an illegal signal state was detected. Check the encoder / state of the encoder signals. Observe the maximum frequencies.</p> <p>For bit 10: The internal communication between the SINAMICS components is faulted or interrupted. Check the DRIVE-CLiQ wiring. Ensure an EMC-compliant design. Observe the maximum permissible quantity structure / clock cycles.</p> <p>For bit 11: The infeed is faulted or has failed. Check the infeed and the surroundings (line supply, filter, reactors, fuses, ...). Check the closed-loop infeed control.</p> <p>For bit 15: Group fault. Determine the precise cause of the fault using the commissioning tool.</p>
--------------	------------------------------------------------------------------------------------------------------------------------------------------------------------------------------------------------------------------------------------------------------------------------------------------------------------------------------------------------------------------------------------------------------------------------------------------------------------------------------------------------------------------------------------------------------------------------------------------------------------------------------------------------------------------------------------------------------------------------------------------------------------------------------------------------------------------------------------------------------------------------------------------------------------------------------------------------------------------------------------------------------------------------------------------------------------------------------------------------------------------------------------------------------------------------------------------------------------------------------------------------------------------------------------------------------------------------------------------------------------------------------------------------------------------------------------------------------------------------------------------------------------------------------------------------------------------------------------------------------------------------------------------------------------------------------------------------------------------------------------------------------------------------------------------------------------------------------------------------------------------------------------------------------------------------------------------------------------------------------------------------------------------------------------------------------------------------------------------------------------------------------------------------------------------------------------------------------------------------------------------------------------------------------------------------------------------------------------------------------------------------------------------------------------------------------------------------------------------------------------------------------------------------------------------

r3120[0...63]**Component fault / Comp fault**

Access level: 3	Calculated: -	Data type: Integer16
Can be changed: -	Scaling: -	Dyn. index: -
Unit group: -	Unit selection: -	Func. diagram: 8060
Min	Max	Factory setting
0	3	-

Description: Displays the component of the fault which has occurred.

Value:

- 0: No assignment
- 1: Control Unit
- 2: Power Module
- 3: Motor

Dependency: Refer to: r0945, r0947, r0948, r0949, r2109, r2130, r2133, r2136, r3122

Note: The buffer parameters are cyclically updated in the background (refer to status signal in r2139).
The structure of the fault buffer and the assignment of the indices is shown in r0945.

r3121[0...63]	Component alarm / Comp alarm		
	Access level: 3	Calculated: -	Data type: Integer16
	Can be changed: -	Scaling: -	Dyn. index: -
	Unit group: -	Unit selection: -	Func. diagram: 8065
	Min	Max	Factory setting
	0	3	-
Description:	Displays the component of the alarm which has occurred.		
Value:	0: No assignment 1: Control Unit 2: Power Module 3: Motor		
Dependency:	Refer to: r2110, r2122, r2123, r2124, r2125, r2134, r2145, r2146, r3123		
Note:	The buffer parameters are cyclically updated in the background (refer to status signal in r2139). The structure of the alarm buffer and the assignment of the indices is shown in r2122.		

r3122[0...63]	Diagnostic attribute fault / Diag_attr fault				
	Access level: 3	Calculated: -	Data type: Unsigned32		
	Can be changed: -	Scaling: -	Dyn. index: -		
	Unit group: -	Unit selection: -	Func. diagram: 8060		
	Min	Max	Factory setting		
	-	-	-		
Description:	Displays the diagnostic attribute of the fault which has occurred.				
Bit field:	Bit	Signal name	1 signal	0 signal	FP
	00	Hardware replacement recommended	Yes	No	-
	15	Message has gone	Yes	No	-
	16	PROFIdrive fault class bit 0	High	Low	-
	17	PROFIdrive fault class bit 1	High	Low	-
	18	PROFIdrive fault class bit 2	High	Low	-
	19	PROFIdrive fault class bit 3	High	Low	-
	20	PROFIdrive fault class bit 4	High	Low	-
Dependency:	Refer to: r0945, r0947, r0948, r0949, r2109, r2130, r2133, r2136, r3120				

Note: The buffer parameters are cyclically updated in the background (refer to status signal in r2139).
 The structure of the fault buffer and the assignment of the indices is shown in r0945.
 For bits 20 ... 16:
 Bits 20, 19, 18, 17, 16 = 0, 0, 0, 0, 0 --> PROFIdrive message class 0: not assigned
 Bits 20, 19, 18, 17, 16 = 0, 0, 0, 0, 1 --> PROFIdrive message class 1: hardware fault/software error
 Bits 20, 19, 18, 17, 16 = 0, 0, 0, 1, 0 --> PROFIdrive message class 2: line fault
 Bits 20, 19, 18, 17, 16 = 0, 0, 0, 1, 1 --> PROFIdrive message class 3: supply voltage fault
 Bits 20, 19, 18, 17, 16 = 0, 0, 1, 0, 0 --> PROFIdrive message class 4: DC link fault
 Bits 20, 19, 18, 17, 16 = 0, 0, 1, 0, 1 --> PROFIdrive message class 5: power electronics faulted
 Bits 20, 19, 18, 17, 16 = 0, 0, 1, 1, 0 --> PROFIdrive message class 6: overtemperature electronic components
 Bits 20, 19, 18, 17, 16 = 0, 0, 1, 1, 1 --> PROFIdrive message class 7: ground fault/phase fault detected
 Bits 20, 19, 18, 17, 16 = 0, 1, 0, 0, 0 --> PROFIdrive message class 8: motor overload
 Bits 20, 19, 18, 17, 16 = 0, 1, 0, 0, 1 --> PROFIdrive message class 9: communication error to the higher-level control
 Bits 20, 19, 18, 17, 16 = 0, 1, 0, 1, 0 --> PROFIdrive message class 10: safe monitoring channel has identified an error
 Bits 20, 19, 18, 17, 16 = 0, 1, 0, 1, 1 --> PROFIdrive message class 11: incorrect position actual value/speed actual value or not available
 Bits 20, 19, 18, 17, 16 = 0, 1, 1, 0, 0 --> PROFIdrive message class 12: internal (DRIVE-CLiQ) communication error
 Bits 20, 19, 18, 17, 16 = 0, 1, 1, 0, 1 --> PROFIdrive message class 13: infeed unit faulted
 Bits 20, 19, 18, 17, 16 = 0, 1, 1, 1, 0 --> PROFIdrive message class 14: braking controller/Braking Module faulted
 Bits 20, 19, 18, 17, 16 = 0, 1, 1, 1, 1 --> PROFIdrive message class 15: line filter faulted
 Bits 20, 19, 18, 17, 16 = 1, 0, 0, 0, 0 --> PROFIdrive message class 16: external measured value/signal state outside the permissible range
 Bits 20, 19, 18, 17, 16 = 1, 0, 0, 0, 1 --> PROFIdrive message class 17: application/technology function faulted
 Bits 20, 19, 18, 17, 16 = 1, 0, 0, 1, 0 --> PROFIdrive message class 18: error in the parameterization/configuration/commissioning sequence
 Bits 20, 19, 18, 17, 16 = 1, 0, 0, 1, 1 --> PROFIdrive message class 19: general drive fault
 Bits 20, 19, 18, 17, 16 = 0, 1, 1, 0, 0 --> PROFIdrive message class 20: auxiliary unit faulted

r3123[0...63]	Diagnostic attribute alarm / Diag_attr alarm		
Access level: 3	Calculated: -	Data type: Unsigned32	
Can be changed: -	Scaling: -	Dyn. index: -	
Unit group: -	Unit selection: -	Func. diagram: 8065	
Min	Max	Factory setting	
-	-	-	

Description: Displays the diagnostic attribute of the alarm which has occurred.

Bit field:	Bit	Signal name	1 signal	0 signal	FP
	00	Hardware replacement recommended	Yes	No	-
	11	Alarm class bit 0	High	Low	-
	12	Alarm class bit 1	High	Low	-
	13	Maintenance required	Yes	No	-
	14	Maintenance urgently required	Yes	No	-
	15	Message has gone	Yes	No	-
	16	PROFIdrive fault class bit 0	High	Low	-
	17	PROFIdrive fault class bit 1	High	Low	-
	18	PROFIdrive fault class bit 2	High	Low	-
	19	PROFIdrive fault class bit 3	High	Low	-
	20	PROFIdrive fault class bit 4	High	Low	-

Dependency: Refer to: r2110, r2122, r2123, r2124, r2125, r2134, r2145, r2146, r3121

2 Parameters

2.2 List of parameters

Note: The buffer parameters are cyclically updated in the background (refer to status signal in r2139).
The structure of the alarm buffer and the assignment of the indices is shown in r2122.

For bit 12, 11:
These status bits are used for the classification of internal alarm classes and are intended for diagnostic purposes only on certain automation systems with integrated SINAMICS functionality.

For bits 20 ... 16:
 Bits 20, 19, 18, 17, 16 = 0, 0, 0, 0, 0 --> PROFIdrive message class 0: not assigned
 Bits 20, 19, 18, 17, 16 = 0, 0, 0, 0, 1 --> PROFIdrive message class 1: hardware fault/software error
 Bits 20, 19, 18, 17, 16 = 0, 0, 0, 1, 0 --> PROFIdrive message class 2: line fault
 Bits 20, 19, 18, 17, 16 = 0, 0, 0, 1, 1 --> PROFIdrive message class 3: supply voltage fault
 Bits 20, 19, 18, 17, 16 = 0, 0, 1, 0, 0 --> PROFIdrive message class 4: DC link fault
 Bits 20, 19, 18, 17, 16 = 0, 0, 1, 0, 1 --> PROFIdrive message class 5: power electronics faulted
 Bits 20, 19, 18, 17, 16 = 0, 0, 1, 1, 0 --> PROFIdrive message class 6: overtemperature electronic components
 Bits 20, 19, 18, 17, 16 = 0, 0, 1, 1, 1 --> PROFIdrive message class 7: ground fault/phase fault detected
 Bits 20, 19, 18, 17, 16 = 0, 1, 0, 0, 0 --> PROFIdrive message class 8: motor overload
 Bits 20, 19, 18, 17, 16 = 0, 1, 0, 0, 1 --> PROFIdrive message class 9: communication error to the higher-level control
 Bits 20, 19, 18, 17, 16 = 0, 1, 0, 1, 0 --> PROFIdrive message class 10: safe monitoring channel has identified an error
 Bits 20, 19, 18, 17, 16 = 0, 1, 0, 1, 1 --> PROFIdrive message class 11: incorrect position actual value/speed actual value or not available
 Bits 20, 19, 18, 17, 16 = 0, 1, 1, 0, 0 --> PROFIdrive message class 12: internal (DRIVE-CLiQ) communication error
 Bits 20, 19, 18, 17, 16 = 0, 1, 1, 0, 1 --> PROFIdrive message class 13: infeed unit faulted
 Bits 20, 19, 18, 17, 16 = 0, 1, 1, 1, 0 --> PROFIdrive message class 14: braking controller/Braking Module faulted
 Bits 20, 19, 18, 17, 16 = 0, 1, 1, 1, 1 --> PROFIdrive message class 15: line filter faulted
 Bits 20, 19, 18, 17, 16 = 1, 0, 0, 0, 0 --> PROFIdrive message class 16: external measured value/signal state outside the permissible range
 Bits 20, 19, 18, 17, 16 = 1, 0, 0, 0, 1 --> PROFIdrive message class 17: application/technology function faulted
 Bits 20, 19, 18, 17, 16 = 1, 0, 0, 1, 0 --> PROFIdrive message class 18: error in the parameterization/configuration/commissioning sequence
 Bits 20, 19, 18, 17, 16 = 1, 0, 0, 1, 1 --> PROFIdrive message class 19: general drive fault
 Bits 20, 19, 18, 17, 16 = 0, 1, 1, 0, 0 --> PROFIdrive message class 20: auxiliary unit faulted

r3131	CO: Actual fault value / Act fault val		
	Access level: 3	Calculated: -	Data type: Integer32
	Can be changed: -	Scaling: -	Dyn. index: -
	Unit group: -	Unit selection: -	Func. diagram: 8060
	Min	Max	Factory setting
	-	-	-
Description:	Displays the fault value of the oldest active fault.		
Dependency:	Refer to: r2131, r3132		

r3132	CO: Actual component number / Comp_no act		
	Access level: 3	Calculated: -	Data type: Integer32
	Can be changed: -	Scaling: -	Dyn. index: -
	Unit group: -	Unit selection: -	Func. diagram: 8060
	Min	Max	Factory setting
	-	-	-
Description:	Displays the component number of the oldest fault that is still active.		
Dependency:	Refer to: r2131, r3131		

p3230[0...n]	CI: Load monitoring speed actual value / Load monit n_act		
	Access level: 3	Calculated: -	Data type: U32 / FloatingPoint32
	Can be changed: T	Scaling: p2000	Dyn. index: CDS, p0170
	Unit group: -	Unit selection: -	Func. diagram: 8012, 8013
	Min	Max	Factory setting
	-	-	0
Description:	Sets the signal source for the speed actual value of the load monitoring.		
Dependency:	Refer to: r2169, p2181, p2192, p2193, p3231 Refer to: A07920, A07921, A07922, F07923, F07924, F07925		
Note:	The parameter is only effective for p2193 = 2.		
p3231[0...n]	Load monitoring speed deviation / Load monit n_dev		
	Access level: 3	Calculated: -	Data type: FloatingPoint32
	Can be changed: U, T	Scaling: -	Dyn. index: DDS, p0180
	Unit group: 3_1	Unit selection: p0505	Func. diagram: 8013
	Min	Max	Factory setting
	0.00 [rpm]	210000.00 [rpm]	150.00 [rpm]
Description:	Sets the permissible speed deviation during load monitoring (for p2193 = 2).		
Dependency:	Refer to: r2169, p2181, p2193, p3230 Refer to: A07920, A07921, A07922, F07923, F07924, F07925		
p3232[0...n]	BI: Load monitoring failure detection / Load_moni fail_det		
	Access level: 3	Calculated: -	Data type: U32 / Binary
	Can be changed: U, T	Scaling: -	Dyn. index: CDS, p0170
	Unit group: -	Unit selection: -	Func. diagram: 8013
	Min	Max	Factory setting
	-	-	1
Description:	Sets the signal source for detecting a failure.		
Dependency:	Refer to: p2192, p2193 Refer to: F07936		
Note:	Monitoring is triggered with a 0 signal, as soon as the time in p2192 has expired.		
p3233[0...n]	Torque actual value filter time constant / M_act_filt T		
	Access level: 3	Calculated: -	Data type: FloatingPoint32
	Can be changed: U, T	Scaling: -	Dyn. index: DDS, p0180
	Unit group: -	Unit selection: -	Func. diagram: 8013
	Min	Max	Factory setting
	0 [ms]	1000000 [ms]	100 [ms]
Description:	Sets the time constant for the PT1 element to smooth the torque actual value. The smoothed torque actual value is compared with the threshold values and is only used for messages and signals.		
p3235	Phase failure signal motor monitoring time / Ph_fail t_monit		
	Access level: 4	Calculated: -	Data type: FloatingPoint32
	Can be changed: U, T	Scaling: -	Dyn. index: -
	Unit group: -	Unit selection: -	Func. diagram: -
	Min	Max	Factory setting
	0 [ms]	2000 [ms]	320 [ms]
Description:	Sets the monitoring time for phase failure detection of the motor.		
Notice:	After the value has been modified, no further parameter modifications can be made and the status is shown in r3996. Modifications can be made again when r3996 = 0.		

2 Parameters

2.2 List of parameters

Note: For p3235 = 0 the function is deactivated.
The monitoring is automatically deactivated during a flying restart for a motor that is still rotating.
3-phase phase failures cannot be detected and are indicated by other messages (e.g. F07902).

r3313	Efficiency optimization 2 optimum flux / Optimum flux		
Access level: 3	Calculated: -	Data type: FloatingPoint32	
Can be changed: -	Scaling: r2004	Dyn. index: -	
Unit group: -	Unit selection: -	Func. diagram: 6722, 6837	
Min	Max	Factory setting	
- [%]	- [%]	- [%]	

Description: Displays the calculated, optimum flux.
Dependency: Refer to: p1401, p3315, p3316
Note: The function is activated via p1401.14 = 1.

p3315[0...n]	Efficiency optimization 2 minimum flux limit value / Min flux lim val		
Access level: 3	Calculated: -	Data type: FloatingPoint32	
Can be changed: U, T	Scaling: -	Dyn. index: DDS, p0180	
Unit group: -	Unit selection: -	Func. diagram: 6722, 6837	
Min	Max	Factory setting	
10.0 [%]	200.0 [%]	50.0 [%]	

Description: Sets the minimal limit value for the calculated optimum flux.
Dependency: Refer to: p1401, r3313, p3316
Note: The function is activated via p1401.14 = 1.

p3316[0...n]	Efficiency optimization 2 maximum flux limit value / Max flux lim val		
Access level: 3	Calculated: -	Data type: FloatingPoint32	
Can be changed: U, T	Scaling: -	Dyn. index: DDS, p0180	
Unit group: -	Unit selection: -	Func. diagram: 6722, 6837	
Min	Max	Factory setting	
10.0 [%]	200.0 [%]	110.0 [%]	

Description: Sets the maximum limit value for the calculated optimum flux.
Dependency: Refer to: p1401, r3313, p3315
Note: The function is activated via p1401.14 = 1.

p3320[0...n]	Fluid flow machine power point 1 / Fluid_mach P1		
Access level: 2	Calculated: -	Data type: FloatingPoint32	
Can be changed: U, T	Scaling: -	Dyn. index: DDS, p0180	
Unit group: -	Unit selection: -	Func. diagram: -	
Min	Max	Factory setting	
0.00	100.00	25.00	

Description: For the energy-saving display of a fluid-flow machine, a typical flow characteristic $P = f(n)$ with 5 points along the characteristic is required.
This parameter specifies the power (P) of point 1 as a [%].
The characteristic comprises the following value pairs:
Power (P) / speed (n)
p3320 / p3321 --> point 1 (P1 / n1)
p3322 / p3323 --> point 2 (P2 / n2)
p3324 / p3325 --> point 3 (P3 / n3)
p3326 / p3327 --> point 4 (P4 / n4)
p3328 / p3329 --> point 5 (P5 / n5)

Dependency: Refer to: r0041, p3321, p3322, p3323, p3324, p3325, p3326, p3327, p3328, p3329
Note: The reference value for power and speed is the rated power/rated speed.
The energy saved is displayed in r0041.

p3321[0...n]	Fluid flow machine speed point 1 / Fluid_mach n1		
	Access level: 2	Calculated: -	Data type: FloatingPoint32
	Can be changed: U, T	Scaling: -	Dyn. index: DDS, p0180
	Unit group: -	Unit selection: -	Func. diagram: -
	Min	Max	Factory setting
	0.00	100.00	0.00
Description:	For the energy-saving display of a fluid-flow machine, a typical flow characteristic $P = f(n)$ with 5 points along the characteristic is required. This parameter specifies the speed (n) of point 1 as a [%]. The characteristic comprises the following value pairs: Power (P) / speed (n) p3320 / p3321 --> point 1 (P1 / n1) p3322 / p3323 --> point 2 (P2 / n2) p3324 / p3325 --> point 3 (P3 / n3) p3326 / p3327 --> point 4 (P4 / n4) p3328 / p3329 --> point 5 (P5 / n5)		
Dependency:	Refer to: r0041, p3320, p3322, p3323, p3324, p3325, p3326, p3327, p3328, p3329		
Note:	The reference value for power and speed is the rated power/rated speed. The energy saved is displayed in r0041.		
p3322[0...n]	Fluid flow machine power point 2 / Fluid_mach P2		
	Access level: 2	Calculated: -	Data type: FloatingPoint32
	Can be changed: U, T	Scaling: -	Dyn. index: DDS, p0180
	Unit group: -	Unit selection: -	Func. diagram: -
	Min	Max	Factory setting
	0.00	100.00	50.00
Description:	For the energy-saving display of a fluid-flow machine, a typical flow characteristic $P = f(n)$ with 5 points along the characteristic is required. This parameter specifies the power (P) of point 2 as a [%].		
Dependency:	Refer to: r0041, p3320, p3321, p3323, p3324, p3325, p3326, p3327, p3328, p3329		
Note:	The reference value for power and speed is the rated power/rated speed. The energy saved is displayed in r0041.		
p3323[0...n]	Fluid flow machine speed point 2 / Fluid_mach n2		
	Access level: 2	Calculated: -	Data type: FloatingPoint32
	Can be changed: U, T	Scaling: -	Dyn. index: DDS, p0180
	Unit group: -	Unit selection: -	Func. diagram: -
	Min	Max	Factory setting
	0.00	100.00	25.00
Description:	For the energy-saving display of a fluid-flow machine, a typical flow characteristic $P = f(n)$ with 5 points along the characteristic is required. This parameter specifies the speed (n) of point 2 as a [%].		
Dependency:	Refer to: r0041, p3320, p3321, p3322, p3324, p3325, p3326, p3327, p3328, p3329		
Note:	The reference value for power and speed is the rated power/rated speed. The energy saved is displayed in r0041.		

p3324[0...n]	Fluid flow machine power point 3 / Fluid_mach P3		
	Access level: 2	Calculated: -	Data type: FloatingPoint32
	Can be changed: U, T	Scaling: -	Dyn. index: DDS, p0180
	Unit group: -	Unit selection: -	Func. diagram: -
	Min	Max	Factory setting
	0.00	100.00	77.00
Description:	For the energy-saving display of a fluid-flow machine, a typical flow characteristic $P = f(n)$ with 5 points along the characteristic is required. This parameter specifies the power (P) of point 3 as a [%].		
Dependency:	Refer to: r0041, p3320, p3321, p3322, p3323, p3325, p3326, p3327, p3328, p3329		
Note:	The reference value for power and speed is the rated power/rated speed. The energy saved is displayed in r0041.		
p3325[0...n]	Fluid flow machine speed point 3 / Fluid_mach n3		
	Access level: 2	Calculated: -	Data type: FloatingPoint32
	Can be changed: U, T	Scaling: -	Dyn. index: DDS, p0180
	Unit group: -	Unit selection: -	Func. diagram: -
	Min	Max	Factory setting
	0.00	100.00	50.00
Description:	For the energy-saving display of a fluid-flow machine, a typical flow characteristic $P = f(n)$ with 5 points along the characteristic is required. This parameter specifies the speed (n) of point 3 as a [%].		
Dependency:	Refer to: r0041, p3320, p3321, p3322, p3323, p3324, p3326, p3327, p3328, p3329		
Note:	The reference value for power and speed is the rated power/rated speed. The energy saved is displayed in r0041.		
p3326[0...n]	Fluid flow machine power point 4 / Fluid_mach P4		
	Access level: 2	Calculated: -	Data type: FloatingPoint32
	Can be changed: U, T	Scaling: -	Dyn. index: DDS, p0180
	Unit group: -	Unit selection: -	Func. diagram: -
	Min	Max	Factory setting
	0.00	100.00	92.00
Description:	For the energy-saving display of a fluid-flow machine, a typical flow characteristic $P = f(n)$ with 5 points along the characteristic is required. This parameter specifies the power (P) of point 4 as a [%].		
Dependency:	Refer to: r0041, p3320, p3321, p3322, p3323, p3324, p3325, p3327, p3328, p3329		
Note:	The reference value for power and speed is the rated power/rated speed. The energy saved is displayed in r0041.		
p3327[0...n]	Fluid flow machine speed point 4 / Fluid_mach n4		
	Access level: 2	Calculated: -	Data type: FloatingPoint32
	Can be changed: U, T	Scaling: -	Dyn. index: DDS, p0180
	Unit group: -	Unit selection: -	Func. diagram: -
	Min	Max	Factory setting
	0.00	100.00	75.00
Description:	For the energy-saving display of a fluid-flow machine, a typical flow characteristic $P = f(n)$ with 5 points along the characteristic is required. This parameter specifies the speed (n) of point 4 as a [%].		
Dependency:	Refer to: r0041, p3320, p3321, p3322, p3323, p3324, p3325, p3326, p3328, p3329		
Note:	The reference value for power and speed is the rated power/rated speed. The energy saved is displayed in r0041.		

p3328[0...n]	Fluid flow machine power point 5 / Fluid_mach P5		
	Access level: 2	Calculated: -	Data type: FloatingPoint32
	Can be changed: U, T	Scaling: -	Dyn. index: DDS, p0180
	Unit group: -	Unit selection: -	Func. diagram: -
	Min	Max	Factory setting
	0.00	100.00	100.00
Description:	For the energy-saving display of a fluid-flow machine, a typical flow characteristic $P = f(n)$ with 5 points along the characteristic is required. This parameter specifies the power (P) of point 5 as a [%].		
Dependency:	Refer to: r0041, p3320, p3321, p3322, p3323, p3324, p3325, p3326, p3327, p3329		
Note:	The reference value for power and speed is the rated power/rated speed. The energy saved is displayed in r0041.		
p3329[0...n]	Fluid flow machine speed point 5 / Fluid_mach n5		
	Access level: 2	Calculated: -	Data type: FloatingPoint32
	Can be changed: U, T	Scaling: -	Dyn. index: DDS, p0180
	Unit group: -	Unit selection: -	Func. diagram: -
	Min	Max	Factory setting
	0.00	100.00	100.00
Description:	For the energy-saving display of a fluid-flow machine, a typical flow characteristic $P = f(n)$ with 5 points along the characteristic is required. This parameter specifies the speed (n) of point 5 as a [%].		
Dependency:	Refer to: r0041, p3320, p3321, p3322, p3323, p3324, p3325, p3326, p3327, p3328		
Note:	The reference value for power and speed is the rated power/rated speed. The energy saved is displayed in r0041.		
p3330[0...n]	BI: 2/3 wire control command 1 / 2/3 wire cmd 1		
G115D I/O	Access level: 3	Calculated: -	Data type: U32 / Binary
	Can be changed: U, T	Scaling: -	Dyn. index: CDS, p0170
	Unit group: -	Unit selection: -	Func. diagram: 2272, 2273
	Min	Max	Factory setting
	-	-	722.0
Description:	Sets the signal source for command 1 for the two-wire control/three-wire control.		
Dependency:	Refer to: p0015, p3331, p3332, r3333, p3334		
Note:	The mode of operation of this binector input is dependent on the wire control set in p0015.		
p3330[0...n]	BI: 2/3 wire control command 1 / 2/3 wire cmd 1		
G115D PN	Access level: 3	Calculated: -	Data type: U32 / Binary
G115D ASI	Can be changed: U, T	Scaling: -	Dyn. index: CDS, p0170
	Unit group: -	Unit selection: -	Func. diagram: 2272, 2273
	Min	Max	Factory setting
	-	-	0
Description:	Sets the signal source for command 1 for the two-wire control/three-wire control.		
Dependency:	Refer to: p0015, p3331, p3332, r3333, p3334		
Note:	The mode of operation of this binector input is dependent on the wire control set in p0015.		

2 Parameters

2.2 List of parameters

p3331[0...n]	BI: 2/3 wire control command 2 / 2/3 wire cmd 2				
G115D I/O	Access level: 3	Calculated: -	Data type: U32 / Binary		
	Can be changed: U, T	Scaling: -	Dyn. index: CDS, p0170		
	Unit group: -	Unit selection: -	Func. diagram: 2272, 2273		
	Min	Max	Factory setting		
	-	-	722.1		
Description:	Sets the signal source for command 2 for the two-wire control/three-wire control.				
Dependency:	Refer to: p0015, p3330, p3332, r3333, p3334				
Note:	The mode of operation of this binector input is dependent on the wire control set in p0015.				
p3331[0...n]	BI: 2/3 wire control command 2 / 2/3 wire cmd 2				
G115D PN	Access level: 3	Calculated: -	Data type: U32 / Binary		
G115D ASI	Can be changed: U, T	Scaling: -	Dyn. index: CDS, p0170		
	Unit group: -	Unit selection: -	Func. diagram: 2272, 2273		
	Min	Max	Factory setting		
	-	-	0		
Description:	Sets the signal source for command 2 for the two-wire control/three-wire control.				
Dependency:	Refer to: p0015, p3330, p3332, r3333, p3334				
Note:	The mode of operation of this binector input is dependent on the wire control set in p0015.				
p3332[0...n]	BI: 2/3 wire control command 3 / 2/3 wire cmd 3				
	Access level: 3	Calculated: -	Data type: U32 / Binary		
	Can be changed: U, T	Scaling: -	Dyn. index: CDS, p0170		
	Unit group: -	Unit selection: -	Func. diagram: 2273		
	Min	Max	Factory setting		
	-	-	0		
Description:	Sets the signal source for command 3 for the two-wire control/three-wire control.				
Dependency:	Refer to: p0015, p3330, p3331, r3333, p3334				
Note:	The mode of operation of this binector input is dependent on the wire control set in p0015.				
r3333.0...3	CO/BO: 2/3 wire control control word / 2/3 wire STW				
	Access level: 3	Calculated: -	Data type: Unsigned32		
	Can be changed: -	Scaling: -	Dyn. index: -		
	Unit group: -	Unit selection: -	Func. diagram: 2272, 2273		
	Min	Max	Factory setting		
	-	-	-		
Description:	Displays the control word for the two wire control/three wire control. The control signals are dependent on the wire control set in p0015 and the signal states at the digital inputs.				
Bit field:	Bit	Signal name	1 signal	0 signal	FP
	00	ON	Yes	No	-
	01	Reversing	Yes	No	-
	02	ON inverted	Yes	No	-
	03	Reversing inverted	Yes	No	-
Dependency:	Refer to: p0015, p3330, p3331, p3332, p3334				
p3334	2/3 wire control selection / 2/3 wire select				
G115D I/O	Access level: 4	Calculated: -	Data type: Integer16		
	Can be changed: U, T	Scaling: -	Dyn. index: -		
	Unit group: -	Unit selection: -	Func. diagram: 2272, 2273		
	Min	Max	Factory setting		
	0	4	1		
Description:	Sets the two wire control/three wire control.				

Value: 0: No wire control
 1: Two wire control clockwise/counterclockwise 1
 2: Two wire control clockwise/counterclockwise 2
 3: Three wire control enable clockwise/counterclockwise
 4: Three wire control enable ON/reversing

Dependency: Refer to: p0015, p3330, p3331, p3332, r3333

Note: This value depends on the wire control set in p0015.

p3334 **2/3 wire control selection / 2/3 wire select**

G115D PN	Access level: 4	Calculated: -	Data type: Integer16
G115D ASI	Can be changed: U, T	Scaling: -	Dyn. index: -
	Unit group: -	Unit selection: -	Func. diagram: 2272, 2273
	Min	Max	Factory setting
	0	4	0

Description: Sets the two wire control/three wire control.

Value: 0: No wire control
 1: Two wire control clockwise/counterclockwise 1
 2: Two wire control clockwise/counterclockwise 2
 3: Three wire control enable clockwise/counterclockwise
 4: Three wire control enable ON/reversing

Dependency: Refer to: p0015, p3330, p3331, p3332, r3333

Note: This value depends on the wire control set in p0015.

p3384 **BI: Stop sensor positive direction signal source / Stop sens pos s_s**

	Access level: 3	Calculated: -	Data type: U32 / Binary
	Can be changed: T	Scaling: -	Dyn. index: -
	Unit group: -	Unit selection: -	Func. diagram: 7040
	Min	Max	Factory setting
	-	-	0

Description: Sets the signal source of the stop sensor for the positive direction.

Dependency: Refer to: p3393

Notice: If the parameter is interconnected with a digital input, then it is possible that it is reset when a macro is executed (p0015).

p3385 **BI: Stop sensor negative direction signal source / Stop sens neg s_s**

	Access level: 3	Calculated: -	Data type: U32 / Binary
	Can be changed: T	Scaling: -	Dyn. index: -
	Unit group: -	Unit selection: -	Func. diagram: 7040
	Min	Max	Factory setting
	-	-	0

Description: Sets the signal source of the stop sensor for the negative direction.

Dependency: Refer to: p3393

Notice: If the parameter is interconnected with a digital input, then it is possible that it is reset when a macro is executed (p0015).

p3386 **BI: Stop sensor center signal source / Stop sens mid s_s**

	Access level: 3	Calculated: -	Data type: U32 / Binary
	Can be changed: T	Scaling: -	Dyn. index: -
	Unit group: -	Unit selection: -	Func. diagram: 7040
	Min	Max	Factory setting
	-	-	0

Description: Sets the signal source for the stop sensor of the middle position.

Dependency: Refer to: p3393

Notice: If the parameter is interconnected with a digital input, then it is possible that it is reset when a macro is executed (p0015).

p3387	BI: Low speed sensor positive direction signal source / Low sens pos s_s		
	Access level: 3	Calculated: -	Data type: U32 / Binary
	Can be changed: T	Scaling: -	Dyn. index: -
	Unit group: -	Unit selection: -	Func. diagram: 7040
	Min	Max	Factory setting
	-	-	0
Description:	Sets the signal source of the low speed sensor for the positive direction.		
Dependency:	Refer to: p3393		
Notice:	If the parameter is interconnected with a digital input, then it is possible that it is reset when a macro is executed (p0015).		
p3388	BI: Low speed sensor negative direction signal source / Low sens neg s_s		
	Access level: 3	Calculated: -	Data type: U32 / Binary
	Can be changed: T	Scaling: -	Dyn. index: -
	Unit group: -	Unit selection: -	Func. diagram: 7040
	Min	Max	Factory setting
	-	-	0
Description:	Sets the signal source of the low speed sensor for the negative direction.		
Dependency:	Refer to: p3393		
Notice:	If the parameter is interconnected with a digital input, then it is possible that it is reset when a macro is executed (p0015).		
p3389	BI: Low speed sensor center signal source / Low sens cntr s_s		
	Access level: 3	Calculated: -	Data type: U32 / Binary
	Can be changed: T	Scaling: -	Dyn. index: -
	Unit group: -	Unit selection: -	Func. diagram: 7040
	Min	Max	Factory setting
	-	-	0
Description:	Sets the signal source of the low speed sensor for the middle position.		
Dependency:	Refer to: p3393		
Notice:	If the parameter is interconnected with a digital input, then it is possible that it is reset when a macro is executed (p0015).		
p3390	BI: Stop/low speed sensor bypass signal source / Sensor bypass s_s		
G115D ASI	Access level: 3	Calculated: -	Data type: U32 / Binary
	Can be changed: T	Scaling: -	Dyn. index: -
	Unit group: -	Unit selection: -	Func. diagram: 7040 9438
	Min	Max	Factory setting
	-	-	2093.4
Description:	Sets the signal source for bypassing the stop and low speed sensors. BI: p3390 = 1 signal: The stop and low speed sensors are not taken into account. BI: p3390 = 0 signal: The stop and low speed sensors are taken into account.		
Dependency:	Refer to: p3384, p3385, p3386, p3387, p3388, p3389, p3393		

p3390	BI: Stop/low speed sensor bypass signal source / Sensor bypass s_s		
G115D I/O	Access level: 3	Calculated: -	Data type: U32 / Binary
	Can be changed: T	Scaling: -	Dyn. index: -
	Unit group: -	Unit selection: -	Func. diagram: 7040
	Min	Max	Factory setting
	-	-	0
Description:	Sets the signal source for bypassing the stop and low speed sensors. BI: p3390 = 1 signal: The stop and low speed sensors are not taken into account. BI: p3390 = 0 signal: The stop and low speed sensors are taken into account.		
Dependency:	Refer to: p3384, p3385, p3386, p3387, p3388, p3389, p3393		
p3390	BI: Stop/low speed sensor bypass signal source / Sensor bypass s_s		
G115D PN	Access level: 3	Calculated: -	Data type: U32 / Binary
	Can be changed: T	Scaling: -	Dyn. index: -
	Unit group: -	Unit selection: -	Func. diagram: 7040 2448
	Min	Max	Factory setting
	-	-	2094.2
Description:	Sets the signal source for bypassing the stop and low speed sensors. BI: p3390 = 1 signal: The stop and low speed sensors are not taken into account. BI: p3390 = 0 signal: The stop and low speed sensors are taken into account.		
Dependency:	Refer to: p3384, p3385, p3386, p3387, p3388, p3389, p3393		
p3391	BI: Stop/low speed sensor bypass manual operation signal source / Sens bypass manual		
	Access level: 3	Calculated: -	Data type: U32 / Binary
	Can be changed: T	Scaling: -	Dyn. index: -
	Unit group: -	Unit selection: -	Func. diagram: 2507 7040
	Min	Max	Factory setting
	-	-	8559.4
Description:	Sets the signal source for bypassing the stop and low speed sensors in the "manual operation" mode. BI: p3391 = 1 signal: The stop and low speed sensors are not taken into account. BI: p3391 = 0 signal: The stop and low speed sensors are taken into account.		
Dependency:	Refer to: p3384, p3385, p3386, p3387, p3388, p3389, p3393		

p3392	End position shutdown activation / End pos shutd act		
	Access level: 3	Calculated: -	Data type: Integer16
	Can be changed: T	Scaling: -	Dyn. index: -
	Unit group: -	Unit selection: -	Func. diagram: 7040
	Min	Max	Factory setting
	0	1	1
Description:	Setting for activating/deactivating the end position shutdown. If value = 0: - End position shutdown is deactivated. - Travel can be continued in both directions. For value = 1: - End position shutdown is activated. - Travel can only be continued in the opposite direction.		
Value:	0: No 1: Yes		
Dependency:	Refer to: p3384, p3385, p3393		
p3393	Conveyor technology application selection / Conveyor tech sel		
	Access level: 3	Calculated: -	Data type: Integer16
	Can be changed: T	Scaling: -	Dyn. index: -
	Unit group: -	Unit selection: -	Func. diagram: 7040
	Min	Max	Factory setting
	0	12	0
Description:	Selects the conveyor technology application.		
Value:	0: Not a conveyor technology application 1: Conveyor, 1 direction / 1 speed 2: Conveyor, 1 direction / 2 speeds 3: Conveyor, 2 directions / 1 speed 4: Conveyor, 2 directions / 2 speeds 5: Turntable, 2 positions / 1 speed 6: Turntable, 2 positions / 2 speeds 7: Turntable, 3 positions / 1 velocity 8: Turntable, 3 positions / 2 speeds 9: Corner turntable lift, 2 positions / 1 speed 10: Corner turntable lift, 2 positions / 2 speeds 11: Traveling trolley, 1 speed 12: Traveling trolley, 2 speeds		
p3394	Stop sensor evaluation type / Stop sensor eval		
	Access level: 3	Calculated: -	Data type: Integer16
	Can be changed: T	Scaling: -	Dyn. index: -
	Unit group: -	Unit selection: -	Func. diagram: 7040
	Min	Max	Factory setting
	1	4	2
Description:	Sets the evaluation type for the stop sensors.		
Value:	1: Input signal 1 level 2: Input signal 0 level 3: Input signal 0/1 edge 4: Input signal 1/0 edge		
Dependency:	Refer to: p3384, p3385, p3386, p3393		

p3395	Low speed sensor evaluation type / Low sensor eval				
	Access level: 3	Calculated: -	Data type: Integer16		
	Can be changed: T	Scaling: -	Dyn. index: -		
	Unit group: -	Unit selection: -	Func. diagram: 7040		
	Min	Max	Factory setting		
	1	4	4		
Description:	Sets the evaluation type for the low speed sensors.				
Value:	1: Input signal 1 level 2: Input signal 0 level 3: Input signal 0/1 edge 4: Input signal 1/0 edge				
Dependency:	Refer to: p3387, p3388, p3389, p3393				
r3396.0...16	CO/BO: Conveyor technology application status / Conveyor tech stat				
	Access level: 3	Calculated: -	Data type: Unsigned32		
	Can be changed: -	Scaling: -	Dyn. index: -		
	Unit group: -	Unit selection: -	Func. diagram: 7040		
	Min	Max	Factory setting		
	-	-	-		
Description:	Display and BICO output for the status of the conveyor technology application.				
Bit field:	Bit	Signal name	1 signal	0 signal	FP
	00	Quick Stop active	Yes	No	-
	01	Quick stop selected	Yes	No	-
	02	Bypass selected	Yes	No	-
	03	Quick stop enabled	Yes	No	-
	04	Positive end position approached	Yes	No	-
	05	Negative end position approached	Yes	No	-
	06	Middle position approached	Yes	No	-
	07	Low speed selected	Yes	No	-
	08	Low speed active	Yes	No	-
	09	Low speed bypass	Yes	No	-
	11	Turntable OFF3	No	Yes	-
	12	Turntable stationary	Yes	No	-
	13	Turntable stop bypass	Yes	No	-
	14	Turntable enabled	Yes	No	-
	15	Corner Turntable Lift enabled	Yes	No	-
	16	Travelling Trolley enabled	Yes	No	-
p3397	CI: Rapid traverse setpoint signal source / Rap trav setp s_s				
	Access level: 3	Calculated: -	Data type: U32 / FloatingPoint32		
	Can be changed: T	Scaling: p2000	Dyn. index: -		
	Unit group: -	Unit selection: -	Func. diagram: 7040		
	Min	Max	Factory setting		
	-	-	0		
Description:	Sets the signal source of the setpoint for rapid traverse. The setpoint for the input is interconnected with the main setpoint.				
Dependency:	Refer to: p1070, p3393				
Notice:	This parameter is automatically set if the application is selected with 2 velocities				

p3398	CI: Low speed setpoint signal source / Low speed setp	Access level: 3 Can be changed: T Unit group: - Min -	Calculated: - Scaling: p2000 Unit selection: - Max -	Data type: U32 / FloatingPoint32 Dyn. index: - Func. diagram: 7040 Factory setting 0
Description:	Sets the signal source of the setpoint for travel with the Low speed. The connector input can be interconnected with a fixed setpoint (p1001 and following) or potentiometer (r0752). If necessary, the setpoint can be transferred via a fieldbus.			
Dependency:	Refer to: p3393			
r3399	CO: Setpoint active / Setpoint active	Access level: 3 Can be changed: - Unit group: 3_1 Min - [rpm]	Calculated: - Scaling: p2000 Unit selection: p0505 Max - [rpm]	Data type: FloatingPoint32 Dyn. index: - Func. diagram: 7040 Factory setting - [rpm]
Description:	Display and connector output for the active setpoint of the conveyor technology application.			
Dependency:	Refer to: p1070, p3393			
Notice:	This parameter is automatically connected with P1071 for PN drive and with P1070 for ASi / IO drive.			
p3820[0...n]	Friction characteristic value n0 / Friction n0	Access level: 2 Can be changed: T Unit group: 3_1 Min 0.00 [rpm]	Calculated: p0340 = 1,3,5 Scaling: - Unit selection: p0505 Max 210000.00 [rpm]	Data type: FloatingPoint32 Dyn. index: DDS, p0180 Func. diagram: 7010 Factory setting 15.00 [rpm]
Description:	The friction characteristic is defined by 10 value pairs. This parameter specifies the n coordinate of the 1st value pair of the friction characteristic.			
Dependency:	Refer to: p3830, p3845			
p3821[0...n]	Friction characteristic value n1 / Friction n1	Access level: 2 Can be changed: T Unit group: 3_1 Min 0.00 [rpm]	Calculated: p0340 = 1,3,5 Scaling: - Unit selection: p0505 Max 210000.00 [rpm]	Data type: FloatingPoint32 Dyn. index: DDS, p0180 Func. diagram: 7010 Factory setting 30.00 [rpm]
Description:	The friction characteristic is defined by 10 value pairs. This parameter specifies the n coordinate of the 2nd value pair of the friction characteristic.			
Dependency:	Refer to: p3831, p3845			
p3822[0...n]	Friction characteristic value n2 / Friction n2	Access level: 2 Can be changed: T Unit group: 3_1 Min 0.00 [rpm]	Calculated: p0340 = 1,3,5 Scaling: - Unit selection: p0505 Max 210000.00 [rpm]	Data type: FloatingPoint32 Dyn. index: DDS, p0180 Func. diagram: 7010 Factory setting 60.00 [rpm]
Description:	The friction characteristic is defined by 10 value pairs. This parameter specifies the n coordinate of the 3rd value pair of the friction characteristic.			
Dependency:	Refer to: p3832, p3845			

p3823[0...n]	Friction characteristic value n3 / Friction n3		
	Access level: 2	Calculated: p0340 = 1,3,5	Data type: FloatingPoint32
	Can be changed: T	Scaling: -	Dyn. index: DDS, p0180
	Unit group: 3_1	Unit selection: p0505	Func. diagram: 7010
	Min	Max	Factory setting
	0.00 [rpm]	210000.00 [rpm]	120.00 [rpm]
Description:	The friction characteristic is defined by 10 value pairs. This parameter specifies the n coordinate of the 4th value pair of the friction characteristic.		
Dependency:	Refer to: p3833, p3845		
p3824[0...n]	Friction characteristic value n4 / Friction n4		
	Access level: 2	Calculated: p0340 = 1,3,5	Data type: FloatingPoint32
	Can be changed: T	Scaling: -	Dyn. index: DDS, p0180
	Unit group: 3_1	Unit selection: p0505	Func. diagram: 7010
	Min	Max	Factory setting
	0.00 [rpm]	210000.00 [rpm]	150.00 [rpm]
Description:	The friction characteristic is defined by 10 value pairs. This parameter specifies the n coordinate of the 5th value pair of the friction characteristic.		
Dependency:	Refer to: p3834, p3845		
p3825[0...n]	Friction characteristic value n5 / Friction n5		
	Access level: 2	Calculated: p0340 = 1,3,5	Data type: FloatingPoint32
	Can be changed: T	Scaling: -	Dyn. index: DDS, p0180
	Unit group: 3_1	Unit selection: p0505	Func. diagram: 7010
	Min	Max	Factory setting
	0.00 [rpm]	210000.00 [rpm]	300.00 [rpm]
Description:	The friction characteristic is defined by 10 value pairs. This parameter specifies the n coordinate of the 6th value pair of the friction characteristic.		
Dependency:	Refer to: p3835, p3845		
p3826[0...n]	Friction characteristic value n6 / Friction n6		
	Access level: 2	Calculated: p0340 = 1,3,5	Data type: FloatingPoint32
	Can be changed: T	Scaling: -	Dyn. index: DDS, p0180
	Unit group: 3_1	Unit selection: p0505	Func. diagram: 7010
	Min	Max	Factory setting
	0.00 [rpm]	210000.00 [rpm]	600.00 [rpm]
Description:	The friction characteristic is defined by 10 value pairs. This parameter specifies the n coordinate of the 7th value pair of the friction characteristic.		
Dependency:	Refer to: p3836, p3845		
p3827[0...n]	Friction characteristic value n7 / Friction n7		
	Access level: 2	Calculated: p0340 = 1,3,5	Data type: FloatingPoint32
	Can be changed: T	Scaling: -	Dyn. index: DDS, p0180
	Unit group: 3_1	Unit selection: p0505	Func. diagram: 7010
	Min	Max	Factory setting
	0.00 [rpm]	210000.00 [rpm]	1200.00 [rpm]
Description:	The friction characteristic is defined by 10 value pairs. This parameter specifies the n coordinate of the 8th value pair of the friction characteristic.		
Dependency:	Refer to: p3837, p3845		

p3828[0...n]	Friction characteristic value n8 / Friction n8		
	Access level: 2	Calculated: p0340 = 1,3,5	Data type: FloatingPoint32
	Can be changed: T	Scaling: -	Dyn. index: DDS, p0180
	Unit group: 3_1	Unit selection: p0505	Func. diagram: 7010
	Min	Max	Factory setting
	0.00 [rpm]	210000.00 [rpm]	1500.00 [rpm]
Description:	The friction characteristic is defined by 10 value pairs. This parameter specifies the n coordinate of the 9th value pair of the friction characteristic.		
Dependency:	Refer to: p3838, p3845		
p3829[0...n]	Friction characteristic value n9 / Friction n9		
	Access level: 2	Calculated: p0340 = 1,3,5	Data type: FloatingPoint32
	Can be changed: T	Scaling: -	Dyn. index: DDS, p0180
	Unit group: 3_1	Unit selection: p0505	Func. diagram: 7010
	Min	Max	Factory setting
	0.00 [rpm]	210000.00 [rpm]	3000.00 [rpm]
Description:	The friction characteristic is defined by 10 value pairs. This parameter specifies the n coordinate of the 10th value pair of the friction characteristic.		
Dependency:	Refer to: p3839, p3845		
p3830[0...n]	Friction characteristic value M0 / Friction M0		
	Access level: 2	Calculated: -	Data type: FloatingPoint32
	Can be changed: T	Scaling: -	Dyn. index: DDS, p0180
	Unit group: 7_1	Unit selection: p0505	Func. diagram: 7010
	Min	Max	Factory setting
	-1000000.0000 [Nm]	1000000.0000 [Nm]	0.0000 [Nm]
Description:	The friction characteristic is defined by 10 value pairs. This parameter specifies the M coordinate of the 1st value pair of the friction characteristic.		
Dependency:	Refer to: p3820, p3845		
p3831[0...n]	Friction characteristic value M1 / Friction M1		
	Access level: 2	Calculated: -	Data type: FloatingPoint32
	Can be changed: T	Scaling: -	Dyn. index: DDS, p0180
	Unit group: 7_1	Unit selection: p0505	Func. diagram: 7010
	Min	Max	Factory setting
	-1000000.0000 [Nm]	1000000.0000 [Nm]	0.0000 [Nm]
Description:	The friction characteristic is defined by 10 value pairs. This parameter specifies the M coordinate of the 2nd value pair of the friction characteristic.		
Dependency:	Refer to: p3821, p3845		
p3832[0...n]	Friction characteristic value M2 / Friction M2		
	Access level: 2	Calculated: -	Data type: FloatingPoint32
	Can be changed: T	Scaling: -	Dyn. index: DDS, p0180
	Unit group: 7_1	Unit selection: p0505	Func. diagram: 7010
	Min	Max	Factory setting
	-1000000.0000 [Nm]	1000000.0000 [Nm]	0.0000 [Nm]
Description:	The friction characteristic is defined by 10 value pairs. This parameter specifies the M coordinate of the 3rd value pair of the friction characteristic.		
Dependency:	Refer to: p3822, p3845		

p3833[0...n]	Friction characteristic value M3 / Friction M3		
	Access level: 2	Calculated: -	Data type: FloatingPoint32
	Can be changed: T	Scaling: -	Dyn. index: DDS, p0180
	Unit group: 7_1	Unit selection: p0505	Func. diagram: 7010
	Min	Max	Factory setting
	-1000000.0000 [Nm]	1000000.0000 [Nm]	0.0000 [Nm]
Description:	The friction characteristic is defined by 10 value pairs. This parameter specifies the M coordinate of the 4th value pair of the friction characteristic.		
Dependency:	Refer to: p3823, p3845		
p3834[0...n]	Friction characteristic value M4 / Friction M4		
	Access level: 2	Calculated: -	Data type: FloatingPoint32
	Can be changed: T	Scaling: -	Dyn. index: DDS, p0180
	Unit group: 7_1	Unit selection: p0505	Func. diagram: 7010
	Min	Max	Factory setting
	-1000000.0000 [Nm]	1000000.0000 [Nm]	0.0000 [Nm]
Description:	The friction characteristic is defined by 10 value pairs. This parameter specifies the M coordinate of the 5th value pair of the friction characteristic.		
Dependency:	Refer to: p3824, p3845		
p3835[0...n]	Friction characteristic value M5 / Friction M5		
	Access level: 2	Calculated: -	Data type: FloatingPoint32
	Can be changed: T	Scaling: -	Dyn. index: DDS, p0180
	Unit group: 7_1	Unit selection: p0505	Func. diagram: 7010
	Min	Max	Factory setting
	-1000000.0000 [Nm]	1000000.0000 [Nm]	0.0000 [Nm]
Description:	The friction characteristic is defined by 10 value pairs. This parameter specifies the M coordinate of the 6th value pair of the friction characteristic.		
Dependency:	Refer to: p3825, p3845		
p3836[0...n]	Friction characteristic value M6 / Friction M6		
	Access level: 2	Calculated: -	Data type: FloatingPoint32
	Can be changed: T	Scaling: -	Dyn. index: DDS, p0180
	Unit group: 7_1	Unit selection: p0505	Func. diagram: 7010
	Min	Max	Factory setting
	-1000000.0000 [Nm]	1000000.0000 [Nm]	0.0000 [Nm]
Description:	The friction characteristic is defined by 10 value pairs. This parameter specifies the M coordinate of the 7th value pair of the friction characteristic.		
Dependency:	Refer to: p3826, p3845		
p3837[0...n]	Friction characteristic value M7 / Friction M7		
	Access level: 2	Calculated: -	Data type: FloatingPoint32
	Can be changed: T	Scaling: -	Dyn. index: DDS, p0180
	Unit group: 7_1	Unit selection: p0505	Func. diagram: 7010
	Min	Max	Factory setting
	-1000000.0000 [Nm]	1000000.0000 [Nm]	0.0000 [Nm]
Description:	The friction characteristic is defined by 10 value pairs. This parameter specifies the M coordinate of the 8th value pair of the friction characteristic.		
Dependency:	Refer to: p3827, p3845		

p3838[0...n]	Friction characteristic value M8 / Friction M8		
	Access level: 2	Calculated: -	Data type: FloatingPoint32
	Can be changed: T	Scaling: -	Dyn. index: DDS, p0180
	Unit group: 7_1	Unit selection: p0505	Func. diagram: 7010
	Min	Max	Factory setting
	-1000000.0000 [Nm]	1000000.0000 [Nm]	0.0000 [Nm]
Description:	The friction characteristic is defined by 10 value pairs. This parameter specifies the M coordinate of the 9th value pair of the friction characteristic.		
Dependency:	Refer to: p3828, p3845		

p3839[0...n]	Friction characteristic value M9 / Friction M9		
	Access level: 2	Calculated: -	Data type: FloatingPoint32
	Can be changed: T	Scaling: -	Dyn. index: DDS, p0180
	Unit group: 7_1	Unit selection: p0505	Func. diagram: 7010
	Min	Max	Factory setting
	-1000000.0000 [Nm]	1000000.0000 [Nm]	0.0000 [Nm]
Description:	The friction characteristic is defined by 10 value pairs. This parameter specifies the M coordinate of the 10th value pair of the friction characteristic.		
Dependency:	Refer to: p3829, p3845		

r3840.0...8	CO/BO: Friction characteristic status word / Friction ZSW				
	Access level: 2	Calculated: -	Data type: Unsigned32		
	Can be changed: -	Scaling: -	Dyn. index: -		
	Unit group: -	Unit selection: -	Func. diagram: 7010		
	Min	Max	Factory setting		
	-	-	-		
Description:	Display and BICO output for the status word of the friction characteristic.				
Bit field:	Bit	Signal name	1 signal	0 signal	FP
	00	Friction characteristic OK	Yes	No	-
	01	Friction characteristic record activated	Yes	No	-
	02	Friction characteristic record completed	Yes	No	-
	03	Friction characteristic record aborted	Yes	No	-
	08	Friction characteristic positive direction	Yes	No	-

r3841	CO: Friction characteristic output / Frict outp		
	Access level: 2	Calculated: -	Data type: FloatingPoint32
	Can be changed: -	Scaling: p2003	Dyn. index: -
	Unit group: 7_1	Unit selection: p0505	Func. diagram: 7010
	Min	Max	Factory setting
	- [Nm]	- [Nm]	- [Nm]
Description:	Display and connector output for the torque of the friction characteristic dependent on the speed.		
Dependency:	Refer to: p3842		

p3842	Friction characteristic activation / Frict act		
	Access level: 2	Calculated: -	Data type: Integer16
	Can be changed: T	Scaling: -	Dyn. index: -
	Unit group: -	Unit selection: -	Func. diagram: 7010
	Min	Max	Factory setting
	0	1	0
Description:	Setting to activate and deactivate the friction characteristic.		
Value:	0: Friction characteristic deactivated 1: Friction characteristic activated		
Dependency:	Refer to: r3841, p3845		

p3845	Friction characteristic record activation / Frict rec act		
	Access level: 2	Calculated: -	Data type: Integer16
	Can be changed: T	Scaling: -	Dyn. index: -
	Unit group: -	Unit selection: -	Func. diagram: 7010
	Min	Max	Factory setting
	0	3	0
Description:	Setting for the friction characteristic record. After the next switch-on command, the friction characteristic is automatically recorded.		
Value:	0: Friction characteristic record deactivated 1: Friction char record activated for all directions 2: Friction char record activated for positive direction 3: Friction char record activated for negative direction		
Dependency:	When selecting the friction characteristic measurement, the drive data set changeover is suppressed. For linear drives (refer to r0108 bit 12) it is not permissible to carry out the friction characteristic measurement for mechanical systems that limit travel.		
Danger:	For drives with a mechanical system that limit the distance moved, it must be ensured that during recording, the friction characteristic is not reached. If this is not the case, then it is not permissible that the measurement is carried out.		
			
Notice:	To permanently accept the determined settings they must be saved in a non-volatile fashion (p0971, p0977).		
Note:	When the friction characteristic record is active, it is not possible to save the parameters (p0971, p0977). When the friction characteristic record is active (p3845 > 0), it is not possible to change p3820 ... p3829, p3830 ... p3839 and p3842. When recording the friction characteristic, in addition to the friction, the motor losses are also determined (e.g. iron losses, eddy current losses and re-magnetizing losses). A differentiation is not made between these individual loss components. We recommend that a motor temperature sensor is used because torque deviations can also be emulated/mapped on the characteristic due to the thermal influence.		
p3846[0...n]	Friction characteristic record ramp-up/ramp-down time / Frict rec t_RU/RD		
	Access level: 2	Calculated: -	Data type: FloatingPoint32
	Can be changed: T	Scaling: -	Dyn. index: DDS, p0180
	Unit group: -	Unit selection: -	Func. diagram: 7010
	Min	Max	Factory setting
	0.000 [s]	999999.000 [s]	10.000 [s]
Description:	Sets the ramp-up/ramp-down time of the ramp-up/ramp-down function generator to automatically record the friction characteristic. The drive is accelerated from standstill (setpoint = 0) up to the maximum speed/velocity (p1082) in this time.		
Dependency:	Refer to: p3845		
p3847[0...n]	Friction characteristic record warm-up time / Frict rec t_warm		
	Access level: 2	Calculated: -	Data type: FloatingPoint32
	Can be changed: T	Scaling: -	Dyn. index: DDS, p0180
	Unit group: -	Unit selection: -	Func. diagram: 7010
	Min	Max	Factory setting
	0.000 [s]	3600.000 [s]	0.000 [s]
Description:	Sets the warm-up time. For an automatic trace (record) to start, the highest selected speed (p3829) is approached and this time is held. After this, the measurement is started with the highest speed.		
Dependency:	Refer to: p3829, p3845		

p3855[0...n]	DC quantity controller configuration / Rect_ctrl config			
	Access level: 3	Calculated: p0340 = 1,3,5	Data type: Unsigned32	
	Can be changed: U, T	Scaling: -	Dyn. index: DDS, p0180	
	Unit group: -	Unit selection: -	Func. diagram: 6797, 6844, 6855	
	Min	Max	Factory setting	
	-	-	0111 bin	
Description:	Sets the configuration for the DC quantity controller in the overmodulation range. There is no DC quantity control for power units that can also be connected through 1 phase to the line supply (r0204.15 = 1).			
Bit field:	Bit	Signal name	1 signal	0 signal
	00	DC quantity controller on	Yes	No
	01	Bandwidth increased	Yes	No
	02	7th harmonic reduced	Yes	No
	03	Filter active	Yes	No
Dependency:	The modulator mode p1802 must enable operation in the overmodulation range. In addition, the overmodulation limit p1803 must be greater than 103 %.			
Notice:	Set the modulator mode p1802 = 10, if the DC quantity control is deactivated and overmodulation is to be prevented. Motor identification must be carried out before activating the DC quantity control in the overmodulation range.			
p3857[0...n]	DC quantity controller P gain / DC_ctrl Kp			
	Access level: 3	Calculated: p0340 = 1,3,4	Data type: FloatingPoint32	
	Can be changed: U, T	Scaling: -	Dyn. index: DDS, p0180	
	Unit group: -	Unit selection: -	Func. diagram: 6797	
	Min	Max	Factory setting	
	0.000	100000.000	0.000	
Description:	Sets the proportional gain of the DC quantity controller for the overmodulation range.			
p3858[0...n]	DC quantity controller integral time / DC_ctrl Tn			
	Access level: 3	Calculated: p0340 = 1,3,4	Data type: FloatingPoint32	
	Can be changed: U, T	Scaling: -	Dyn. index: DDS, p0180	
	Unit group: -	Unit selection: -	Func. diagram: 6797	
	Min	Max	Factory setting	
	0.00 [ms]	1000.00 [ms]	2.00 [ms]	
Description:	Sets the integral time for the DC quantity controller.			
r3859.1	CO/BO: Compound braking/DC quantity control status word / Comp-br/DC_ctr ZSW			
	Access level: 3	Calculated: -	Data type: Unsigned32	
	Can be changed: -	Scaling: -	Dyn. index: -	
	Unit group: -	Unit selection: -	Func. diagram: 6797	
	Min	Max	Factory setting	
	-	-	-	
Description:	Display and connector output for the status word of the DC quantity control.			
Bit field:	Bit	Signal name	1 signal	0 signal
	01	DC quantity control active in the overmodulation range	Yes	No

p3900	Completion of quick commissioning / Compl quick_comm		
	Access level: 1	Calculated: -	Data type: Integer16
	Can be changed: C(1)	Scaling: -	Dyn. index: -
	Unit group: -	Unit selection: -	Func. diagram: -
	Min	Max	Factory setting
	0	3	0
Description:	<p>Exits quick commissioning (p0010 = 1) with automatic calculation of all parameters of all existing drive data sets that depend on the entries made during quick commissioning.</p> <p>p3900 = 1 initially includes a parameter reset (factory setting, the same as p0970 = 1) for all parameters of the drive object; however, without overwriting the entries made during the quick commissioning.</p> <p>The interconnections of PROFIBUS PZD telegram selection (p0922) and the interconnections via p15 and p1500 are re-established and all of the dependent motor, open-loop and control-loop control parameters are calculated (corresponding to p0340 = 1).</p> <p>p3900 = 2 includes the restoration of the interconnections of PROFIBUS PZD telegram selection (p0922) and the interconnections via p15 and p1500 and the calculations corresponding to p0340 = 1.</p> <p>p3900 = 3 only includes the calculations associated with the motor, open-loop and closed-loop control parameters corresponding to p0340 = 1.</p>		
Value:	<p>0: No quick parameterization</p> <p>1: Quick parameterization after parameter reset</p> <p>2: Quick parameterization (only) for BICO and motor parameters</p> <p>3: Quick parameterization for motor parameters (only)</p>		
Notice:	After the value has been modified, no further parameter modifications can be made and the status is shown in r3996. Modifications can be made again when r3996 = 0.		
Note:	<p>When the calculations have been completed, p3900 and p0010 are automatically reset to a value of zero.</p> <p>When calculating motor, open-loop and closed-loop control parameters (such as for p0340 = 1) parameters associated with a selected Siemens catalog motor are not overwritten.</p> <p>If a catalog motor has not been selected (p0300), then the following parameters are reset with p3900 > 0 in order to restore the situation that applied when commissioning the drive for the first time:</p> <p>induction motor: p0320, p0352, p0362 ... p0369, p0604, p0605, p0626 ... p0628</p> <p>synchronous motor: p0326, p0327, p0352, p0604, p0605</p>		

r3925[0...n]	Identification final display / Ident final_disp				
	Access level: 3	Calculated: p0340 = 1	Data type: Unsigned32		
	Can be changed: -	Scaling: -	Dyn. index: DDS, p0180		
	Unit group: -	Unit selection: -	Func. diagram: -		
	Min	Max	Factory setting		
	-	-	-		
Description:	Displays the commissioning steps that have been carried out.				
Bit field:	Bit	Signal name	1 signal	0 signal	FP
	00	Motor/control parameters calculated (p0340 = 1, p3900 > 0)	Yes	No	-
	02	Motor data identification carried out at standstill (p1910 = 1)	Yes	No	-
	03	Rotating measurement carried out (p1960 = 1, 2)	Yes	No	-
	08	Identified motor data are automatically backed up	Yes	No	-
	11	Automatic parameterization as Standard Drive Control	Yes	No	-
	12	Automatic parameterization as Dynamic Drive Control	Yes	No	-
	14	First motor commissioning	Yes	No	-
	15	Equivalent circuit diagram parameters changed	Yes	No	-
	18	Circle identification executed	Yes	No	-
Note:	The individual bits are only set if the appropriate action has been initiated and successfully completed. The identification final display is reset when changing the type plate parameters.				

r3926[0...n]	Voltage generation alternating base voltage amplitude / U_gen altern base				
	Access level: 4	Calculated: -	Data type: FloatingPoint32		
	Can be changed: -	Scaling: -	Dyn. index: DDS, p0180		
	Unit group: -	Unit selection: -	Func. diagram: -		
	Min	Max	Factory setting		
	- [V]	- [V]	- [V]		
Description:	Displays the base voltage for the alternating voltage in the context of motor data identification.				
	0: No alternating voltages. The function is deactivated.				
	<0: Automatic determination of the base voltage and wobulation / self-setting based on the converter and the connected motor.				
	Otherwise: Base voltage for alternating current generation in volts (wobulation active).				
r3927[0...n]	Motor data identification control word / MotID STW				
	Access level: 3	Calculated: p0340 = 1	Data type: Unsigned32		
	Can be changed: -	Scaling: -	Dyn. index: DDS, p0180		
	Unit group: -	Unit selection: -	Func. diagram: -		
	Min	Max	Factory setting		
	-	-	-		
Description:	Successfully completed component of the last motor data identification carried out.				
Bit field:	Bit	Signal name	1 signal	0 signal	FP
	00	Stator inductance estimate no measurement	Yes	No	-
	02	Rotor time constant estimate no measurement	Yes	No	-
	03	Leakage inductance estimate no measurement	Yes	No	-
	05	Determine Tr and Lsig evaluation in the time range	Yes	No	-
	06	Activate vibration damping	Yes	No	-
	07	Deactivate vibration detection	Yes	No	-
	11	Deactivate pulse measurement Lq Ld	Yes	No	-
	12	Deactivate rotor resistance Rr measurement	Yes	No	-
	14	Deactivate valve interlocking time measurement	Yes	No	-
	15	Determine only stator resistance, valve voltage fault, dead time	Yes	No	-
	16	Short motor identification (lower quality)	Yes	No	-
	17	Measurement without control parameter calculation	Yes	No	-
	18	After motID direct transition into operation	Yes	No	-
	19	After MotID automatically save results	Yes	No	-
	20	Estimate cable resistance	Yes	No	-
	21	Calibrating the output voltage measurement	Yes	No	-
	22	Only identify circle	Yes	No	-
	23	Deactivate circle identification	Yes	No	-
	24	Circle identification with 0 and 90 degrees	Yes	No	-
	26	Measure with long cable	Yes	No	-
Dependency:	Refer to: r3925				
Note:	The parameter is a copy of p1909.				

r3928[0...n]		Rotating measurement configuration / Rot meas config			
Access level: 3		Calculated: p0340 = 1	Data type: Unsigned16		
Can be changed: -		Scaling: -	Dyn. index: DDS, p0180		
Unit group: -		Unit selection: -	Func. diagram: -		
Min		Max	Factory setting		
-		-	-		
Description:	Successfully completed component of the last rotating measurement carried out.				
Bit field:	Bit	Signal name	1 signal	0 signal	FP
	01	Saturation characteristic identification	Yes	No	-
	02	Moment of inertia identification	Yes	No	-
	03	Re-calculates the speed controller parameters	Yes	No	-
	04	Speed controller optimization (vibration test)	Yes	No	-
	05	q leakage inductance ident. (for current controller adaptation)	Yes	No	-
	11	Do not change the controller parameters during the measurement	Yes	No	-
	12	Measurement shortened	Yes	No	-
	13	After measurement direct transition into operation	Yes	No	-
	14	Calculate speed actual value smoothing time	Yes	No	-
Dependency:	Refer to: r3925				
Note:	The parameter is a copy of p1959.				

r3929[0...n]		Motor data identification modulated voltage generation / MotID U_gen mod			
Access level: 4		Calculated: p0340 = 1	Data type: Unsigned32		
Can be changed: -		Scaling: -	Dyn. index: DDS, p0180		
Unit group: -		Unit selection: -	Func. diagram: -		
Min		Max	Factory setting		
-		-	-		
Description:	Configuration of voltage generation for the various MotID sections in the case of the most recent successful MotID.				
Bit field:	Bit	Signal name	1 signal	0 signal	FP
	00	Wobble U_generate to determine dead-time correction	Yes	No	-
	01	Wobble U_generate to determine stator resistance	Yes	No	-
	02	Wobble U_generation to determine rotor time constant	Yes	No	-
	03	Wobble U_generation to determine leakage inductance	Yes	No	-
	04	Wobble U_generation to determine dynamic leakage inductance	Yes	No	-
	05	Wobble U_generation to determine magnetizing inductance	Yes	No	-
	08	Alternating U_generate to determine dead-time correction	Yes	No	-
	09	Alternating U_generate to determine stator resistance	Yes	No	-
	10	Alternating U_generate to determine rotor time constant	Yes	No	-
	11	Alternating U_generate to determine leakage inductance	Yes	No	-
	12	Alternating U_generate to determine dyn. leakage inductance	Yes	No	-
	13	Alternating U_generate to determine magnetizing inductance	Yes	No	-

r3930[0...4]	Power unit EEPROM characteristics / PU characteristics				
	Access level: 3	Calculated: -	Data type: Unsigned16		
	Can be changed: -	Scaling: -	Dyn. index: -		
	Unit group: -	Unit selection: -	Func. diagram: -		
	Min	Max	Factory setting		
	-	-	-		
Description:	Displays the characteristics (A5E number and versions) of the power unit. [0]: A5E number xxxx (A5Exxxxxyyy) [1]: A5E number yyyy (A5Exxxxxyyy) [2]: File version (logistic) [3]: File version (fixed data) [4]: File version (calib data)				
p3950	Service parameter / Serv par				
	Access level: 3	Calculated: -	Data type: Unsigned16		
	Can be changed: C, U, T	Scaling: -	Dyn. index: -		
	Unit group: -	Unit selection: -	Func. diagram: -		
	Min	Max	Factory setting		
	-	-	-		
Description:	For service personnel only.				
r3960[0...1]	Control Unit temperature measured / CU temp measured				
	Access level: 3	Calculated: -	Data type: FloatingPoint32		
	Can be changed: -	Scaling: p2006	Dyn. index: -		
	Unit group: -	Unit selection: -	Func. diagram: -		
	Min	Max	Factory setting		
	- [°C]	- [°C]	- [°C]		
Description:	Displays the measured Control Unit temperature. An appropriate message is output when 87 °C is exceeded.				
Index:	[0] = Actual measured value [1] = Maximum measured value				
Dependency:	Refer to: A01009				
Note:	The value of -200 indicates that there is no measuring signal. For r3960[0]: Displays the currently measured Control Unit temperature. For r3960[1]: Displays the highest measured Control Unit temperature. This value is saved on the module in a non-volatile fashion.				
r3974	Drive unit status word / Drv_unit ZSW				
	Access level: 1	Calculated: -	Data type: Unsigned32		
	Can be changed: -	Scaling: -	Dyn. index: -		
	Unit group: -	Unit selection: -	Func. diagram: -		
	Min	Max	Factory setting		
	-	-	-		
Description:	Displays the status word for the drive unit.				
Bit field:	Bit	Signal name	1 signal	0 signal	FP
	00	Software reset active	Yes	No	-
	01	Writing of parameters disabled as parameter save in progress	Yes	No	-
	02	Writing of parameters disabled as macro is running	Yes	No	-

r3978	BICO CounterDevice / BICO CounterDevice		
	Access level: 4	Calculated: -	Data type: Unsigned32
	Can be changed: -	Scaling: -	Dyn. index: -
	Unit group: -	Unit selection: -	Func. diagram: -
	Min	Max	Factory setting
	-	-	-
Description:	Displays the counter reading for modified BICO interconnections on this device. The counter is incremented by one for each modified BICO interconnection.		
p3981	Acknowledge drive object faults / Ackn DO faults		
	Access level: 3	Calculated: -	Data type: Unsigned8
	Can be changed: U, T	Scaling: -	Dyn. index: -
	Unit group: -	Unit selection: -	Func. diagram: 8060
	Min	Max	Factory setting
	0	1	0
Description:	Setting to acknowledge all active faults of a drive object.		
Notice:	Safety messages cannot be acknowledged using this parameter.		
Note:	Parameter should be set from 0 to 1 to acknowledge. After acknowledgment, the parameter is automatically reset to 0.		
p3985	Master control mode selection / PcCtrl mode select		
	Access level: 3	Calculated: -	Data type: Integer16
	Can be changed: U, T	Scaling: -	Dyn. index: -
	Unit group: -	Unit selection: -	Func. diagram: -
	Min	Max	Factory setting
	0	1	0
Description:	Sets the mode to change over the master control / LOCAL mode.		
Value:	0: Change master control for STW1.0 = 0 1: Change master control in operation		
Danger:	When changing the master control in operation, the drive can manifest undesirable behavior - e.g. it can accelerate up to another setpoint.		
			
r3986	Number of parameters / Param count		
	Access level: 3	Calculated: -	Data type: Unsigned16
	Can be changed: -	Scaling: -	Dyn. index: -
	Unit group: -	Unit selection: -	Func. diagram: -
	Min	Max	Factory setting
	-	-	-
Description:	Displays the number of parameters for this drive unit. The number comprises the device-specific and the drive-specific parameters.		
Dependency:	Refer to: r0980, r0981, r0989		
r3988[0...1]	Boot state / Boot_state		
	Access level: 4	Calculated: -	Data type: Integer16
	Can be changed: -	Scaling: -	Dyn. index: -
	Unit group: -	Unit selection: -	Func. diagram: -
	Min	Max	Factory setting
	0	800	-
Description:	Index 0: Displays the boot state. Index 1: Displays the partial boot state		

2 Parameters

2.2 List of parameters

Value:	0:	Not active
	1:	Fatal fault
	10:	Fault
	20:	Reset all parameters
	30:	Drive object modified
	40:	Download using commissioning software
	50:	Parameter download using commissioning software
	90:	Reset Control Unit
	100:	Start initialization
	101:	Only for internal Siemens use
	110:	Instantiate Control Unit basis
	111:	Insert drive object
	112:	Only for internal Siemens use
	113:	Only for internal Siemens use
	114:	Only for internal Siemens use
	115:	Parameter download using commissioning software
	117:	Only for internal Siemens use
	150:	Wait until Power Module is determined
	160:	Evaluate Power Module
	170:	Instantiate Control Unit reset
	180:	Only for internal Siemens use
	200:	First commissioning
	210:	Create drive packages
	250:	Wait for fault acknowledge
	325:	Wait for input of drive type
	350:	Determine drive type
	360:	Only for internal Siemens use
	370:	Wait until p0010 is set to 0
	380:	Only for internal Siemens use
	550:	Call conversion functions for parameter
	625:	Wait for non-cyclic start
	650:	Start cyclic operation
	660:	Evaluate drive commissioning status
	670:	Only for internal Siemens use
	680:	Only for internal Siemens use
	690:	Wait for non-cyclic start
	700:	Save parameters
	725:	Wait for cyclic
	740:	Check the ability to operate
	745:	Start cyclic calculations
	750:	Interrupt enable
	800:	Initialization finished
Index:	[0]	= System
	[1]	= Partial boot

r3996[0...1]	Parameter write inhibit status / Par_write inhib st		
	Access level: 3	Calculated: -	Data type: Unsigned8
	Can be changed: -	Scaling: -	Dyn. index: -
	Unit group: -	Unit selection: -	Func. diagram: -
	Min	Max	Factory setting
	-	-	-
Description:	Displays whether writing to parameters is inhibited. r3996[0] = 0: Parameter write not inhibited. 0 < r3996[0] < 100: Parameter write inhibited. The value shows how the calculations are progressing.		
Index:	[0] = Progress calculations [1] = Cause		
Note:	For index [1]: Only for internal Siemens troubleshooting.		

p5271[0...n]		Online tuning configuration controller / Ot config ctrl		
Access level:	3	Calculated:	-	
Can be changed:	T	Scaling:	-	
Unit group:	-	Unit selection:	-	
Min	-	Max	-	
			Data type:	Unsigned16
			Dyn. index:	DDS, p0180
			Func. diagram:	5045
			Factory setting	0000 1100 bin
Description:	Sets the configuration for the online tuning.			
Bit field:	Bit	Signal name	1 signal	0 signal
	00	PD controller for large load moments of inertia	Yes	No
	01	Reduce gain at low speeds	Yes	No
	02	Load adaptation Kp	Yes	No
	03	Speed precontrol	Yes	No
	04	Torque precontrol	Yes	No
	05	Setting maximum acceleration limiting	Yes	No
	06	Do not change Kp	Yes	No
Dependency:	Refer to: p5272, p5273, r5274, p5275			
Note:	<p>For bit 00: For significant differences between the motor and load moment of inertia, or for low dynamic performance of the controller, then the P controller becomes a PD controller in the position control loop. As a consequence, the dynamic performance of the position controller is increased. This function should only be set when the speed precontrol (bit 3 = 1) or the torque precontrol (bit 4 = 1) is active.</p> <p>For bit 01: At low speeds, the controller gain factors are automatically reduced in order to avoid noise and oscillation at standstill.</p> <p>For bit 02: The estimated load moment of inertia is taken into account for the speed controller gain (see p5273).</p> <p>For bit 03: Activates the speed precontrol for the basic positioner (EPOS).</p> <p>For bit 04: Activates the torque precontrol for the basic positioner (EPOS).</p> <p>For bit 05: The maximum setpoint acceleration for the basic positioner (EPOS) is determined based on the estimated moment of inertia. This is realized by activating the bit once. The prerequisite is that the drive pulses are inhibited, and the moment of inertia was previously determined.</p> <p>For bit 06: The speed controller gain set in p1460 is not changed when calculating the controller data.</p>			

p5272[0...n]		Online tuning dynamic factor / Ot dyn_factor		
Access level:	2	Calculated:	-	
Can be changed:	U, T	Scaling:	-	
Unit group:	-	Unit selection:	-	
Min	5.0 [%]	Max	1000.0 [%]	
			Data type:	FloatingPoint32
			Dyn. index:	DDS, p0180
			Func. diagram:	-
			Factory setting	100.0 [%]
Description:	Sets the dynamic factor for the P gain of the speed controller for online tuning.			
Dependency:	Refer to: p5271, p5273, r5274, p5275			
Notice:	The speed control can become unstable for excessively high values.			
Note:	The stiffer the mechanical load coupling, the higher the dynamic factor can be set.			

p5273[0...n]	Online tuning dynamic factor load / Ot dyn_factor load			
	Access level: 3	Calculated: -	Data type: FloatingPoint32	
	Can be changed: U, T	Scaling: -	Dyn. index: DDS, p0180	
	Unit group: -	Unit selection: -	Func. diagram: 5045	
	Min	Max	Factory setting	
	0.0 [%]	100.0 [%]	30.0 [%]	
Description:	Sets the dynamic factor for the P gain of the speed controller for online tuning. The value specifies which component of the estimated load moment of inertia is taken into account when adapting the speed controller.			
Dependency:	Refer to: p5271, p5272, r5274, p5275			
Notice:	The speed control can become unstable for excessively high values.			
r5274	CO: Online tuning dynamic estimated / Ot dyn estimate			
	Access level: 3	Calculated: -	Data type: FloatingPoint32	
	Can be changed: -	Scaling: -	Dyn. index: -	
	Unit group: -	Unit selection: -	Func. diagram: 5045	
	Min	Max	Factory setting	
	- [ms]	- [ms]	- [ms]	
Description:	Display and connector output for the estimated dynamic response of the speed control loop as PT1 time constant for online tuning.			
Dependency:	Refer to: p5271, p5272, p5273, p5275			
p5275[0...n]	Online tuning dynamic time constant / Ot dyn T			
	Access level: 3	Calculated: -	Data type: FloatingPoint32	
	Can be changed: U, T	Scaling: -	Dyn. index: DDS, p0180	
	Unit group: -	Unit selection: -	Func. diagram: 5045	
	Min	Max	Factory setting	
	0.0 [ms]	60.0 [ms]	7.5 [ms]	
Description:	Sets the time constant for the precontrol symmetrization for online tuning. As a consequence, the drive is allocated a defined, dynamic response via its precontrol. For drives, which must interpolate with one another, the same value must be entered. Examples: 0 ms = travel without following error (Kv factor is infinity) 5 ms = settling behavior as for PT1 with 5 ms (Kv factor = 12 [1000/min])			
Dependency:	Refer to: p5271, p5272, p5273, r5274			
Notice:	This time constant is only effective if p5302.7 is set = 1. Otherwise, the precontrol symmetrization is adapted to the estimated dynamic response, therefore setting positioning without any overshoot.			
p5310[0...n]	Moment of inertia precontrol configuration / J_est config			
	Access level: 3	Calculated: -	Data type: Unsigned32	
	Can be changed: U, T	Scaling: -	Dyn. index: DDS, p0180	
	Unit group: -	Unit selection: -	Func. diagram: -	
	Min	Max	Factory setting	
	-	-	0000 bin	
Description:	Configuration of the moment of inertia precontrol when the moment of inertia estimator is active.			
Bit field:	Bit	Signal name	1 signal	0 signal
	00	Activating calculations	Yes	No
	01	Activating the moment of inertia precontrol	Yes	No
Dependency:	The function module "Moment of inertia estimator" (r0108.10) must be activated for the "Moment of inertia precontrol" function. Refer to: r5311, p5312, p5313, p5314, p5315			

Note: Possible bit combinations:
 Bit 1, 0
 = 0, 0 --> function not active
 = 0, 1 --> cyclic calculation of the coefficients without moment of inertia precontrol (commissioning)
 = 1, 0 --> moment of inertia precontrol activated (without cyclic calculation of the coefficients)
 = 1, 1 --> moment of inertia precontrol activated (with cyclic calculation of the coefficients)
 For bit 00:
 Calculation for the constant and linear coefficients of the moment of inertia precontrol is activated. The results are written to parameters (p5312, p5313, p5314, p5315).
 For bit 01:
 The moment of inertia precontrol is activated.
 The moment of inertia is calculated from the currently measured load torque and the saved coefficients (p5312, p5313, p5314, p5315).

r5311[0...n]	Moment of inertia precontrol status word / J_prectrl ZSW			
Access level: 3	Calculated: -	Data type: Unsigned32		
Can be changed: -	Scaling: -	Dyn. index: DDS, p0180		
Unit group: -	Unit selection: -	Func. diagram: -		
Min	Max	Factory setting		
-	-	-		
Description:	Displays the status word for the moment of inertia precontrol.			
Bit field:	Bit	Signal name	1 signal	0 signal
	00	New measuring points are available	Yes	No
	01	New parameters being calculated	Yes	No
	02	Moment of inertia precontrol active	Yes	No
	03	Calculation of positive coefficients completed	Yes	No
	04	Calculation of negative coefficients completed	Yes	No
	05	Results are being written to parameter	Yes	No
Dependency:	The function module "Moment of inertia estimator" (r0108.10) must be activated for the "Moment of inertia precontrol" function. Refer to: p5310, p5312, p5313, p5314, p5315			

p5312[0...n]	Moment of inertia precontrol linear positive / J_est lin pos		
Access level: 3	Calculated: p0340 = 1	Data type: FloatingPoint32	
Can be changed: U, T	Scaling: -	Dyn. index: DDS, p0180	
Unit group: -	Unit selection: -	Func. diagram: -	
Min	Max	Factory setting	
-340.28235E36 [s^2]	340.28235E36 [s^2]	0.000000 [s^2]	
Description:	Sets the linear coefficients for moment of inertia precontrol in the positive direction when the moment of inertia estimator is active. The estimated moment of inertia is obtained according to the following formula: Moment of inertia (J) = linear coefficient (p5312) * load torque + constant coefficient (p5313)		
Dependency:	The function module "Moment of inertia estimator" (r0108.10) must be activated for the "Moment of inertia precontrol" function. Refer to: p5310, r5311, p5313, p5314, p5315		

p5313[0...n]	Moment of inertia precontrol constant positive / J_est const pos		
	Access level: 3	Calculated: p0340 = 1	Data type: FloatingPoint32
	Can be changed: U, T	Scaling: -	Dyn. index: DDS, p0180
	Unit group: 25_1	Unit selection: p0100	Func. diagram: -
	Min	Max	Factory setting
	-340.28235E36 [kgm ²]	340.28235E36 [kgm ²]	0.000000 [kgm ²]
Description:	Sets of the constant coefficients for moment of inertia precontrol in the positive direction when the moment of inertia estimator is active. The estimated moment of inertia is obtained according to the following formula: Moment of inertia (J) = linear coefficient (p5312) * load torque + constant coefficient (p5313)		
Dependency:	The function module "Moment of inertia estimator" (r0108.10) must be activated for the "Moment of inertia precontrol" function. Refer to: p5310, r5311, p5312, p5314, p5315		
p5314[0...n]	Moment of inertia precontrol linear negative / J_est lin neg		
	Access level: 3	Calculated: p0340 = 1	Data type: FloatingPoint32
	Can be changed: U, T	Scaling: -	Dyn. index: DDS, p0180
	Unit group: -	Unit selection: -	Func. diagram: -
	Min	Max	Factory setting
	-340.28235E36 [s ²]	340.28235E36 [s ²]	0.000000 [s ²]
Description:	Sets the linear coefficients for moment of inertia precontrol in the negative direction when the moment of inertia estimator is active. The estimated moment of inertia is obtained according to the following formula: Moment of inertia (J) = linear coefficient (p5314) * load torque + constant coefficient (p5315)		
Dependency:	The function module "Moment of inertia estimator" (r0108.10) must be activated for the "Moment of inertia precontrol" function. Refer to: p5310, r5311, p5312, p5313, p5315		
p5315[0...n]	Moment of inertia precontrol constant negative / J_est const neg		
	Access level: 3	Calculated: p0340 = 1	Data type: FloatingPoint32
	Can be changed: U, T	Scaling: -	Dyn. index: DDS, p0180
	Unit group: 25_1	Unit selection: p0100	Func. diagram: -
	Min	Max	Factory setting
	-340.28235E36 [kgm ²]	340.28235E36 [kgm ²]	0.000000 [kgm ²]
Description:	Sets the constant coefficients for moment of inertia precontrol in the negative direction when the moment of inertia estimator is active. The estimated moment of inertia is obtained according to the following formula: Moment of inertia (J) = linear coefficient (p5314) * load torque + constant coefficient (p5315)		
Dependency:	The function module "Moment of inertia estimator" (r0108.10) must be activated for the "Moment of inertia precontrol" function. Refer to: p5310, r5311, p5312, p5313, p5314		
p5316[0...n]	Moment of inertia precontrol change time moment of inertia / J_prectrl t J		
	Access level: 3	Calculated: p0340 = 1,3,4	Data type: FloatingPoint32
	Can be changed: U, T	Scaling: -	Dyn. index: DDS, p0180
	Unit group: -	Unit selection: -	Func. diagram: -
	Min	Max	Factory setting
	10.00 [ms]	5000.00 [ms]	500.00 [ms]
Description:	Sets the change time for the moment of inertia for the moment of inertia precontrol. Lower values mean that faster changes are possible. For a higher value, this estimated value is smoothed more significantly.		
Dependency:	Refer to: p1400, p1560, p1562		

p5350[0...n]	Mot_temp_mod 1/3 boost factor at standstill / Standst boost_fact				
	Access level: 2	Calculated: -	Data type: FloatingPoint32		
	Can be changed: U, T	Scaling: -	Dyn. index: DDS, p0180		
	Unit group: -	Unit selection: -	Func. diagram: -		
	Min	Max	Factory setting		
	1.0000	2.0000	2.0000		
Description:	<p>Sets the boost factor for the copper losses at standstill for motor temperature models 1 and 3. The entered factor is active for speed $n = 0$ [rpm]. This factor is linearly reduced down to 1 between speeds $n = 0 \dots 1$ [rpm]. The following values are required to calculate the boost factor:</p> <ul style="list-style-type: none"> - stall current (I₀, p0318, catalog value) - thermal stall current (I_{th0}, catalog value) <p>The boost factor is calculated as follows:</p> <ul style="list-style-type: none"> - $p5350 = (I_0 / I_{th0})^2$ 				
Dependency:	<p>Refer to: p0318, p0612, p5390, p5391 Refer to: F07011, A07012, A07014</p>				
Notice:	<p>When selecting a catalog motor (p0301), this parameter is automatically pre-assigned and is write protected. Information in p0300 should be carefully observed when removing write protection.</p>				
Note:	<p>Temperature model 1 (I2t): The following applies for firmware version < 4.7 SP6 or p0612.8 = 0: - parameter p5350 is not active. Internally, a fixed boost factor of 1.333 is used as basis for the calculation. The following applies from firmware version 4.7 SP6 and p0612.8 = 1: - parameter p5350 becomes active as described above.</p>				
r5389.0...8	CO/BO: Mot_temp status word faults/alarms / Mot_temp ZSW F/A				
	Access level: 2	Calculated: -	Data type: Unsigned16		
	Can be changed: -	Scaling: -	Dyn. index: -		
	Unit group: -	Unit selection: -	Func. diagram: 8016		
	Min	Max	Factory setting		
	-	-	-		
Description:	Display and BICO output for faults and alarms of the motor temperature monitoring.				
Bit field:	Bit	Signal name	1 signal	0 signal	FP
	00	Motor temperature measurement fault active	Yes	No	-
	01	Motor temperature model fault active	Yes	No	-
	02	Encoder temperature measurement fault active	Yes	No	-
	04	Motor temperature measurement alarm active	Yes	No	-
	05	Motor temperature measurement alarm active	Yes	No	-
	08	Current reduction active	Yes	No	-
Dependency:	<p>Refer to: r0034, p0612, r0632 Refer to: F07011, A07012, A07910</p>				

2 Parameters

2.2 List of parameters

Note: For bit 00, 04:
The motor temperature is measured using a temperature sensor (p0600, p0601). When the bit is set, a high temperature is identified, and a corresponding signal is additionally output.

For bit 01, 05:
The motor temperature is monitored based on a temperature model (p0612). When the bit is set, a high temperature is identified, and a corresponding signal is additionally output.

For bit 02:
The encoder temperature is measured using a temperature sensor. When the bit is set, a high temperature is identified, and a corresponding signal is additionally output.

For bit 08:
When reaching the motor temperature alarm threshold, reduction of the maximum current is set as response (p0610 = 1). When the bit is set, reduction of the maximum current is active.

p5390[0...n]	Mot_temp_mod 1/3 alarm threshold / A thresh		
	Access level: 2	Calculated: -	Data type: FloatingPoint32
	Can be changed: U, T	Scaling: -	Dyn. index: DDS, p0180
	Unit group: 21_1	Unit selection: p0505	Func. diagram: -
	Min	Max	Factory setting
	0.0 [°C]	200.0 [°C]	110.0 [°C]
Description:	Sets the alarm threshold for monitoring the motor temperature for motor temperature models 1 and 3. The stator winding temperature (r0632) is used to initiate the signal. The following applies for temperature model 1 (I2t): - only effective from firmware version 4.7 SP6 and p0612.8 = 1. - Alarm A07012 is output after the alarm threshold is exceeded. - when commissioning a catalog motor for the first time, the threshold value is copied from p0605 to p5390. The following applies for temperature model 3: - after the alarm threshold is exceeded, alarm A07012 is output and a calculated delay time (t = p5371/p5381) is started. - if the delay time has expired and the alarm threshold has, in the meantime, not been fallen below, then fault F07011 is output.		
Dependency:	Refer to: r0034, p0605, p0612, r0632, p5391 Refer to: F07011, A07012, A07014		
Notice:	When selecting a catalog motor (p0301), this parameter is automatically pre-assigned and is write protected. Information in p0300 should be carefully observed when removing write protection.		
Note:	The hysteresis is 2 K.		

p5391[0...n]	Mot_temp_mod 1/3 fault threshold / F thresh		
	Access level: 2	Calculated: -	Data type: FloatingPoint32
	Can be changed: U, T	Scaling: -	Dyn. index: DDS, p0180
	Unit group: 21_1	Unit selection: p0505	Func. diagram: -
	Min	Max	Factory setting
	0.0 [°C]	200.0 [°C]	120.0 [°C]
Description:	Sets the fault threshold for monitoring the motor temperature for motor temperature models 1 and 3. Fault F07011 is output after the fault threshold is exceeded. The stator winding temperature (r0632) is used to initiate the signal. The following applies for temperature model 1 (I2t): - only effective from firmware version 4.7 SP6 and p0612.8 = 1. - when commissioning a catalog motor for the first time, the threshold value is copied from p0615 to p5391.		
Dependency:	Refer to: r0034, p0612, p0615, r0632, p5390 Refer to: F07011, A07014		
Notice:	When selecting a catalog motor (p0301), this parameter is automatically pre-assigned and is write protected. Information in p0300 should be carefully observed when removing write protection.		
Note:	The hysteresis is 2 K.		

r5397	Mot_temp_mod 3 ambient temperature image p0613 / AmbTmp image p0613		
	Access level: 2	Calculated: -	Data type: FloatingPoint32
	Can be changed: -	Scaling: -	Dyn. index: -
	Unit group: 21_1	Unit selection: p0505	Func. diagram: 8019
	Min	Max	Factory setting
	- [°C]	- [°C]	- [°C]
Description:	Displays the ambient temperature for motor temperature models 1 and 3. This value is used to calculate the utilization display (p0034). The parameter value is an image of p0613.		
Dependency:	Refer to: r0034		
Note:	For firmware version < 4.7 SP6: parameter p0613 is not visible for users (this is a Siemens internal parameter).		
r5398[0...n]	Mot_temp_mod 3 alarm threshold image p5390 / A thr image p5390		
	Access level: 2	Calculated: -	Data type: FloatingPoint32
	Can be changed: -	Scaling: -	Dyn. index: DDS, p0180
	Unit group: 21_1	Unit selection: p0505	Func. diagram: 8019
	Min	Max	Factory setting
	- [°C]	- [°C]	- [°C]
Description:	Displays the alarm threshold for monitoring the motor temperature for motor temperature models 1 and 3. This value is used to calculate the utilization display (p0034). The parameter value is an image of p5390.		
Dependency:	Refer to: p5390 Refer to: F07011, A07012, A07014		
Note:	For firmware version < 4.7 SP6: parameter p5390 is not visible for users (this is a Siemens internal parameter).		
r5399[0...n]	Mot_temp_mod 3 fault threshold image p5391 / F thr image p5391		
	Access level: 2	Calculated: -	Data type: FloatingPoint32
	Can be changed: -	Scaling: -	Dyn. index: DDS, p0180
	Unit group: 21_1	Unit selection: p0505	Func. diagram: 8019
	Min	Max	Factory setting
	- [°C]	- [°C]	- [°C]
Description:	Sets the fault threshold for monitoring the motor temperature for motor temperature models 1 and 3. Fault F07011 is output after the fault threshold is exceeded. The parameter value is an image of p5391.		
Dependency:	Refer to: p5391 Refer to: F07011, A07012, A07014		
Note:	For firmware version < 4.7 SP6: parameter p5391 is not visible for users (this is a Siemens internal parameter).		
r5600	Pe energy-saving mode ID / Pe mode ID		
G115D PN	Access level: 3	Calculated: -	Data type: Integer16
	Can be changed: -	Scaling: -	Dyn. index: -
	Unit group: -	Unit selection: -	Func. diagram: 2381, 2382
	Min	Max	Factory setting
	0	255	-
Description:	Displays the PROFIenergy mode ID of the effective energy-saving mode.		
Value:	0: POWER OFF 2: Energy-saving mode 2 240: Operation 255: Ready		
Note:	Pe: PROFIenergy profiles		

p5602[0...1]	Pe energy-saving mode pause time minimal / Pe mod t_pause min		
G115D PN	Access level: 3	Calculated: -	Data type: Unsigned32
	Can be changed: T	Scaling: -	Dyn. index: -
	Unit group: -	Unit selection: -	Func. diagram: 2381
	Min	Max	Factory setting
	300000 [ms]	4294967295 [ms]	[0] 300000 [ms] [1] 480000 [ms]
Description:	Sets the minimum possible pause time for the energy-saving mode. The value is the sum of the following times: - Energy-saving mode transition time - Operating state transition time regular - Energy-saving mode, time of minimum stay		
Index:	[0] = Reserved [1] = Mode 2		
Note:	It is not permissible that the value is less than the sum of the "energy-saving mode transition time" and the "operating state transition time" (system properties). Pe: PROFenergy profiles		

p5606[0...1]	Pe energy-saving mode time of maximum stay / Pe t_max_stay		
G115D PN	Access level: 3	Calculated: -	Data type: Unsigned32
	Can be changed: T	Scaling: -	Dyn. index: -
	Unit group: -	Unit selection: -	Func. diagram: 2381
	Min	Max	Factory setting
	0 [ms]	4294967295 [ms]	4294967295 [ms]
Description:	Sets the time of maximum stay for the energy-saving mode.		
Index:	[0] = Reserved [1] = Mode 2		
Note:	Pe: PROFenergy profiles		

p5611	Pe energy-saving properties general / Pe properties gen				
G115D PN	Access level: 3	Calculated: -	Data type: Unsigned32		
	Can be changed: T	Scaling: -	Dyn. index: -		
	Unit group: -	Unit selection: -	Func. diagram: 2381, 2382		
	Min	Max	Factory setting		
	-	-	0000 bin		
Description:	Sets the general properties for energy-saving.				
Bit field:	Bit	Signal name	1 signal	0 signal	FP
	00	Inhibit PROFenergy control commands	Yes	No	-
	01	Drive initiates OFF1 when transitioning to energy-saving mode	Yes	No	-
	02	Trans to energy-saving mode from PROFdrive state S3/4 poss	Yes	No	-
Note:	Pe: PROFenergy profiles PROFdrive state S4: operation				

p5612[0...1]	Pe energy-saving properties mode-dependent / Pe properties mod		
G115D PN	Access level: 3	Calculated: -	Data type: Unsigned32
	Can be changed: T	Scaling: -	Dyn. index: -
	Unit group: -	Unit selection: -	Func. diagram: -
	Min	Max	Factory setting
	-	-	[0] 0110 bin [1] 0000 bin
Description:	Sets the mode-dependent properties for energy-saving.		

Index: [0] = Reserved
[1] = Mode 2

Bit field:	Bit	Signal name	1 signal	0 signal	FP
	00	Reserved	Yes	No	-

Note: Pe: PROFlenergy profiles

r5613.0...1 CO/BO: Pe energy-saving active/inactive / Pe save act/inact

G115D PN	Access level: 3	Calculated: -	Data type: Unsigned8
	Can be changed: -	Scaling: -	Dyn. index: -
	Unit group: -	Unit selection: -	Func. diagram: 2382
	Min	Max	Factory setting
	-	-	-

Description: Display and binector output for the state display PROFlenergy energy saving active or inactive.

Bit field:	Bit	Signal name	1 signal	0 signal	FP
	00	Pe active	Yes	No	-
	01	Pe inactive	Yes	No	-

Note: Bit 0 and bit 1 are inverse of one another.
Pe: PROFlenergy profiles

p5614 BI: Pe set switching on inhibited signal source / Pe sw-on_inh s_s

G115D PN	Access level: 3	Calculated: -	Data type: U32 / Binary
	Can be changed: T	Scaling: -	Dyn. index: -
	Unit group: -	Unit selection: -	Func. diagram: 2382
	Min	Max	Factory setting
	-	-	0

Description: Sets the signal source to set in the PROFIdrive state S1 "switching on inhibited".

Dependency: Refer to: r5613

Note: Pe: PROFlenergy profiles

p6397 Motor module phase shift second system / MM ph_sh 2nd sys

Access level: 3	Calculated: -	Data type: Integer16
Can be changed: T	Scaling: -	Dyn. index: -
Unit group: -	Unit selection: -	Func. diagram: -
Min	Max	Factory setting
0	8	0

Description: Sets the phase shift of the second system with respect to the first system for the motor module for a 12-pulse gating unit.

Value:

0:	Shift by +30 °
1:	Shift by -30 °
2:	Shift by 0 °
3:	Shift by +90 °
4:	Shift by -90 °
5:	Shift by +120 °
6:	Shift by -120 °
7:	Shift by +150 °
8:	Shift by -150 °

Notice: The parameter is only evaluated if p7003 = 2.

Note: For p6397 = 0 the following applies: The second systems leads for a positive direction of rotation.

For p6397 = 1 the following applies: The second systems lags for a positive direction of rotation.

r7758[0...19]	KHP Control Unit serial number / KHP CU ser_no		
	Access level: 3	Calculated: -	Data type: Unsigned8
	Can be changed: -	Scaling: -	Dyn. index: -
	Unit group: -	Unit selection: -	Func. diagram: -
	Min	Max	Factory setting
	-	-	-
Description:	Displays the actual serial number of the Control Unit. The individual characters of the serial number are displayed in the ASCII code in the indices. For the commissioning software, the ASCII characters are displayed uncoded.		
Dependency:	Refer to: p7765, p7766, p7767, p7768		
Notice:	An ASCII table (excerpt) can be found, for example, in the appendix to the List Manual.		
Note:	KHP: Know-How Protection		

p7759[0...19]	KHP Control Unit reference serial number / KHP CU ref ser_no		
	Access level: 3	Calculated: -	Data type: Unsigned8
	Can be changed: T	Scaling: -	Dyn. index: -
	Unit group: -	Unit selection: -	Func. diagram: -
	Min	Max	Factory setting
	-	-	-
Description:	Sets the reference serial number for the Control Unit. Using this parameter, if a Control Unit and/or a memory card is replaced at the end customer, the OEM can again adapt the project to the modified hardware.		
Dependency:	Refer to: p7765, p7766, p7767, p7768		
Note:	KHP: Know-How Protection - the OEM may only change this parameter for the use case "Sending encrypted SINAMICS data". - SINAMICS only evaluates this parameter when powering up from the encrypted "Load into file system..." output or when powering up from the encrypted PS files. The evaluation is only made when know-how protection and memory card copy protection have been activated.		

r7760.0...12	CO/BO: Write protection/know-how protection status / Wr_prot/KHP stat				
	Access level: 3	Calculated: -	Data type: Unsigned16		
	Can be changed: -	Scaling: -	Dyn. index: -		
	Unit group: -	Unit selection: -	Func. diagram: -		
	Min	Max	Factory setting		
	-	-	-		
Description:	Displays the status for the write protection and know-how protection.				
Bit field:	Bit	Signal name	1 signal	0 signal	FP
	00	Write protection active	Yes	No	-
	01	Know-how protection active	Yes	No	-
	02	Know-how protection temporarily withdrawn	Yes	No	-
	03	Know-how protection cannot be deactivated	Yes	No	-
	04	Extended copy protection is active	Yes	No	-
	05	Basic copy protection is active	Yes	No	-
	06	Trace and measuring functions for diagnostic purposes active	Yes	No	-
	12	Reserved Siemens	Yes	No	-
Dependency:	Refer to: p7761, p7765, p7766, p7767, p7768				

Note: KHP: Know-How Protection

For bit 00:
Write protection can be activated/deactivated via p7761 on the Control Unit.

For bit 01:
The know-how protection can be activated by entering a password (p7766 ... p7768).

For bit 02:
If it has already been activated, know-how protection can be temporarily deactivated by entering the valid password in p7766. In this case, bit 1 = 0 and bit 2 = 1 offset.

For bit 03:
Know-how protection cannot be deactivated, as p7766 is not entered in the OEM exception list (only the factory setting is possible). This bit is only set if know-how protection is active (bit 1 = 1) and p7766 has not been entered in the OEM exception list.

For bit 04:
When know-how protection has been activated, the contents of the memory card (parameter and DCC data) can be additionally protected against being used with other memory cards/Control Units. This bit is only set if know-how protection is active and p7765 bit 00 is set.

For bit 05:
When know-how protection has been activated, the contents of the memory card (parameter and DCC data) can be additionally protected against being used with other memory cards. This bit is only set if know-how protection is active and in p7765 bit 01 is set and not bit 00.

For bit 06:
When know-how protection is activated, the drive data can be traced using the device trace function. This bit is only set if know-how protection is active and in p7765.2 is set.

p7761	Write protection / Write protection		
	Access level: 3	Calculated: -	Data type: Integer16
	Can be changed: U, T	Scaling: -	Dyn. index: -
	Unit group: -	Unit selection: -	Func. diagram: -
	Min	Max	Factory setting
	0	1	0
Description:	Setting for activating/deactivating the write protection for adjustable parameters.		
Value:	0: Deactivate write protection 1: Activate write protection		
Dependency:	Refer to: r7760		
Note:	Parameters with the "WRITE_NO_LOCK" attributes are excluded from the write protection. A product-specific list of these parameters is also available in the corresponding List Manual.		

p7762	Write protection multi-master fieldbus system access behavior / Fieldbus acc_behav		
	Access level: 3	Calculated: -	Data type: Integer16
	Can be changed: U, T	Scaling: -	Dyn. index: -
	Unit group: -	Unit selection: -	Func. diagram: -
	Min	Max	Factory setting
	0	1	0
Description:	Sets the behavior for write protection when accessing via multi-master fieldbus systems (e.g. CAN, BACnet).		
Value:	0: Write access independent of p7761 1: Write access dependent on p7761		
Dependency:	Refer to: r7760, p7761		

p7763	KHP OEM exception list number of indices for p7764 / KHP OEM qty p7764		
	Access level: 3	Calculated: -	Data type: Unsigned16
	Can be changed: U, T	Scaling: -	Dyn. index: -
	Unit group: -	Unit selection: -	Func. diagram: -
	Min	Max	Factory setting
	1	500	1
Description:	Sets the number of parameters for the OEM exception list (p7764[0...n]). p7764[0...n], with n = p7763 - 1		
Dependency:	Refer to: p7764		
Note:	KHP: Know-How Protection Even if know-how protection is set, parameters in this list can be read and written to.		

p7764[0...n]	KHP OEM exception list / KHP OEM excep list		
	Access level: 3	Calculated: -	Data type: Unsigned16
	Can be changed: U, T	Scaling: -	Dyn. index: p7763
	Unit group: -	Unit selection: -	Func. diagram: -
	Min	Max	Factory setting
	0	65535	[0] 7766 [1...499] 0
Description:	OEM exception list (p7764[0...n]) for setting parameters that should be excluded from know-how protection. p7764[0...n], with n = p7763 - 1		
Dependency:	The number of indices depends on p7763. Refer to: p7763		
Note:	KHP: Know-How Protection Even if know-how protection is set, parameters in this list can be read and written to.		

p7765	KHP configuration / KHP config				
	Access level: 3	Calculated: -	Data type: Unsigned16		
	Can be changed: U, T	Scaling: -	Dyn. index: -		
	Unit group: -	Unit selection: -	Func. diagram: -		
	Min	Max	Factory setting		
	-	-	0000 bin		
Description:	Configuration settings for know-how protection. For bit 00, 01: When KHP is activated, this means that the OEM can define whether the parameters and DCC data encrypted on the memory card should be protected before using on other memory cards/Control Units. For bit 02: This means that the OEM can define whether it is possible or not to trace the drive data using the device trace function although KHP is activated.				
Bit field:	Bit	Signal name	1 signal	0 signal	FP
	00	Extended copy protection - linked to the memory card and CU	Yes	No	-
	01	Basic copy protection - linked to the memory card	Yes	No	-
	02	Permit trace and measuring functions for diagnostic purposes	Yes	No	-
Dependency:	Refer to: p7766, p7767, p7768				
Note:	KHP: Know-How Protection For copy protection, the serial numbers of the memory card and/or Control Unit are checked. The memory card copy protection and preventing data to be traced are only effective when the know-how protection has been activated. For bit 00, 01: If both bits are inadvertently set to 1 (e.g. at the BOP), then the setting of bit 0 applies. There is no copy protection if both bits are set to 0.				

p7766[0...29]	KHP password input / KHP passw input		
	Access level: 3	Calculated: -	Data type: Unsigned16
	Can be changed: U, T	Scaling: -	Dyn. index: -
	Unit group: -	Unit selection: -	Func. diagram: -
	Min	Max	Factory setting
	-	-	-
Description:	Sets the password for know-how protection. Example of a password: 123aBc = 49 50 51 97 66 99 dec (ASCII characters) [0] = character 1 (e.g. 49 dec) [1] = character 2 (e.g. 50 dec) ... [5] = character 6 (e.g. 99 dec) [29] = 0 dec (completes the entry)		
Dependency:	Refer to: p7767, p7768		
Notice:	An ASCII table (excerpt) can be found, for example, in the appendix to the List Manual. When using the STARTER commissioning software, the password should be entered using the associated dialogs. The following rules apply when entering the password: - password entry must start with p7766[0]. - no gaps are permissible in the password. - entering a password is completed when writing to p7766[29] (p7766[29] = 0 for passwords less than 30 characters).		
Note:	KHP: Know-How Protection When reading, p7766[0...29] = 42 dec (ASCII character = "**") is displayed. Parameters with the "KHP_WRITE_NO_LOCK" attribute are not involved in the know-how protection. Parameters with the "KHP_ACTIVE_READ" attribute can be read even when know-how protection is activated. A product-specific list of these parameters is also available in the corresponding List Manual.		
p7767[0...29]	KHP password new / KHP passw new		
	Access level: 3	Calculated: -	Data type: Unsigned16
	Can be changed: U, T	Scaling: -	Dyn. index: -
	Unit group: -	Unit selection: -	Func. diagram: -
	Min	Max	Factory setting
	-	-	-
Description:	Sets the new password for know-how protection.		
Dependency:	Refer to: p7766, p7768		
Note:	KHP: Know-How Protection When reading, p7767[0...29] = 42 dec (ASCII character = "**") is displayed.		
p7768[0...29]	KHP password confirmation / KHP passw confirm		
	Access level: 3	Calculated: -	Data type: Unsigned16
	Can be changed: U, T	Scaling: -	Dyn. index: -
	Unit group: -	Unit selection: -	Func. diagram: -
	Min	Max	Factory setting
	-	-	-
Description:	Confirms the new password for know-how protection.		
Dependency:	Refer to: p7766, p7767		
Note:	KHP: Know-How Protection When reading, p7768[0...29] = 42 dec (ASCII character = "**") is displayed.		

p7769[0...20]	KHP memory card reference serial number / KHP mem ref ser_no		
	Access level: 3	Calculated: -	Data type: Unsigned8
	Can be changed: T	Scaling: -	Dyn. index: -
	Unit group: -	Unit selection: -	Func. diagram: -
	Min	Max	Factory setting
	-	-	-
Description:	Sets the reference serial number for the memory card. Using this parameter, if a Control Unit and/or a memory card is replaced at the end customer, the OEM can again adapt the project to the modified hardware.		
Dependency:	Refer to: p7765, p7766, p7767, p7768		
Note:	KHP: Know-How Protection - the OEM may only change this parameter for the use case "Sending encrypted SINAMICS data". - SINAMICS only evaluates this parameter when powering up from the encrypted "Load into file system..." output or when powering up from the encrypted PS files. The evaluation is only made when know-how protection and memory card copy protection have been activated.		

p7775	NVRAM data backup/import/delete / NVRAM backup		
	Access level: 3	Calculated: -	Data type: Integer16
	Can be changed: C, U, T	Scaling: -	Dyn. index: -
	Unit group: -	Unit selection: -	Func. diagram: -
	Min	Max	Factory setting
	0	17	0
Description:	Setting to backup/import/delete NVRAM data. NVRAM data are non-volatile data in the device (e.g. fault buffer). For NVRAM data actions, the following data are excluded: - crash diagnostics - CU operating hours counter - CU temperature - safety logbook		
Value:	0: Inactive 1: NVRAM data backup to memory card 2: Import NVRAM data from the memory card 3: Delete NVRAM data in the device 10: Error when clearing 11: Error when backing up, memory card not available 12: Error when backing up, insufficient memory space 13: Error when backing up 14: Error when importing, memory card not available 15: Error when importing, checksum error 16: Error when importing, no NVRAM data available 17: Error when importing		
Notice:	For value = 2, 3: These actions are only possible when pulses are inhibited.		
Note:	After the action has been successfully completed, the parameter is automatically set to zero. The actions importing and deleting NVRAM data immediately initiate a warm restart. If the procedure was not successfully completed, then an appropriate fault value is displayed (p7775 >= 10).		

r7841[0...15]	Power Module serial number / PM serial no.		
	Access level: 4	Calculated: -	Data type: Unsigned8
	Can be changed: -	Scaling: -	Dyn. index: -
	Unit group: -	Unit selection: -	Func. diagram: -
	Min	Max	Factory setting
	-	-	-
Description:	Displays the actual serial number of the Power Module. The individual characters of the serial number are displayed in the ASCII code in the indices.		

Notice: An ASCII table (excerpt) can be found, for example, in the appendix to the List Manual.

r7843[0...20]	Memory card serial number / Mem_card ser.no		
Access level: 1	Calculated: -	Data type: Unsigned8	
Can be changed: -	Scaling: -	Dyn. index: -	
Unit group: -	Unit selection: -	Func. diagram: -	
Min	Max	Factory setting	
-	-	-	

Description: Displays the actual serial number of the memory card.
The individual characters of the serial number are displayed in the ASCII code in the indices.

Notice: An ASCII table (excerpt) can be found, for example, in the appendix to the List Manual.

Note: Example: displaying the serial number for a memory card:
r7843[0] = 49 dec --> ASCII characters = "1" --> serial number, character 1
r7843[1] = 49 dec --> ASCII characters = "1" --> serial number, character 2
r7843[2] = 49 dec --> ASCII characters = "1" --> serial number, character 3
r7843[3] = 57 dec --> ASCII characters = "9" --> serial number, character 4
r7843[4] = 50 dec --> ASCII characters = "2" --> serial number, character 5
r7843[5] = 51 dec --> ASCII characters = "3" --> serial number, character 6
r7843[6] = 69 dec --> ASCII characters = "E" --> serial number, character 7
r7843[7] = 0 dec --> ASCII characters = " " --> serial number, character 8
...
r7843[19] = 0 dec --> ASCII characters = " " --> serial number, character 20
r7843[20] = 0 dec
Serial number = 111923E

r7844[0...2]	Memory card/device memory firmware version / Mem_crd/dev_mem FW		
Access level: 2	Calculated: -	Data type: Unsigned32	
Can be changed: -	Scaling: -	Dyn. index: -	
Unit group: -	Unit selection: -	Func. diagram: -	
Min	Max	Factory setting	
-	-	-	

Description: Displays the version of the firmware stored on the memory medium of the drive device.
Depending on the drive device being used, the memory medium is a memory card, or an internal non-volatile device memory.

Index: [0] = Internal
[1] = External
[2] = Parameter backup

Note: For index [0]:
Displays the internal firmware version (e.g. 04402315).
This firmware version is the version of the memory card/device memory and not the CU firmware (r0018), however, normally they have the same versions.
For index [1]:
Displays the external firmware version (e.g. 04040000 -> 4.4).
For automation systems with SINAMICS Integrated this is the runtime version of the automation system.
For index [2]:
Displays the internal firmware version of the parameter backup.
With this CU firmware version, the parameter backup was saved, which was used when powering up.

r7901[0...81]	Sampling times / t_sample		
	Access level: 4	Calculated: -	Data type: FloatingPoint32
	Can be changed: -	Scaling: -	Dyn. index: -
	Unit group: -	Unit selection: -	Func. diagram: -
	Min	Max	Factory setting
	- [µs]	- [µs]	- [µs]
Description:	Displays the sampling times currently present on the drive unit. r7901[0...63]: sampling times of hardware time slices. r7901[64...82]: sampling times of software time slices. r7901[x] = 0, means the following: No methods have been registered in the time slice involved.		
Note:	The basis for the software time slices is T_NRK = p7901[13].		

r8540.0...15	BO: STW1 from IOP in the manual mode / STW1 IOP				
	Access level: 3	Calculated: -	Data type: Unsigned16		
	Can be changed: -	Scaling: -	Dyn. index: -		
	Unit group: -	Unit selection: -	Func. diagram: -		
	Min	Max	Factory setting		
	-	-	-		
Description:	For the manual mode: the STW1 (control word 1) entered from the IOP is displayed.				
Bit field:	Bit	Signal name	1 signal	0 signal	FP
	00	ON/OFF1	Yes	No	-
	01	OC / OFF2	Yes	No	-
	02	OC / OFF3	Yes	No	-
	03	Reserved	Yes	No	-
	04	Reserved	Yes	No	-
	05	Reserved	Yes	No	-
	06	Reserved	Yes	No	-
	07	Acknowledge fault	Yes	No	-
	08	Jog bit 0	Yes	No	3030
	09	Jog bit 1	Yes	No	3030
	10	Reserved	Yes	No	-
	11	Direction reversal (setpoint)	Yes	No	-
	12	Reserved	Yes	No	-
	13	Reserved	Yes	No	-
	14	Reserved	Yes	No	-
	15	Reserved	Yes	No	-

r8541	CO: Speed setpoint from the IOP in the manual mode / n_set IOP		
	Access level: 3	Calculated: -	Data type: FloatingPoint32
	Can be changed: -	Scaling: p2000	Dyn. index: -
	Unit group: 3_1	Unit selection: p0505	Func. diagram: -
	Min	Max	Factory setting
	- [rpm]	- [rpm]	- [rpm]
Description:	For the manual mode: the speed setpoint entered from the IOP is displayed.		

p8542[0...15]	BI: Active STW1 in the BOP/IOP manual mode / STW1 act OP		
Access level: 3	Calculated: -	Data type: U32 / Binary	
Can be changed: T	Scaling: -	Dyn. index: -	
Unit group: -	Unit selection: -	Func. diagram: -	
Min	Max	Factory setting	
-	-	[0] 8540.0	
		[1] 8540.1	
		[2] 8540.2	
		[3] 8540.3	
		[4] 8540.4	
		[5] 8540.5	
		[6] 8540.6	
		[7] 8540.7	
		[8] 8540.8	
		[9] 8540.9	
		[10] 8540.10	
		[11] 8540.11	
		[12] 8540.12	
		[13] 8540.13	
		[14] 8540.14	
		[15] 8540.15	

Description: For the manual mode: Setting of the signal sources for STW1 (control word 1).

Index:
 [0] = ON/OFF1
 [1] = OC / OFF2
 [2] = OC / OFF3
 [3] = Enable operation
 [4] = Enable ramp-function generator
 [5] = Continue ramp-function generator
 [6] = Enable speed setpoint
 [7] = Acknowledge fault
 [8] = Jog bit 0
 [9] = Jog bit 1
 [10] = Master control by PLC
 [11] = Direction reversal (setpoint)
 [12] = Enable speed controller
 [13] = Motorized potentiometer raise
 [14] = Motorized potentiometer lower
 [15] = CDS bit 0

p8543	CI: Active speed setpoint in the BOP/IOP manual mode / N_act act OP		
Access level: 3	Calculated: -	Data type: U32 / FloatingPoint32	
Can be changed: T	Scaling: p2000	Dyn. index: -	
Unit group: -	Unit selection: -	Func. diagram: -	
Min	Max	Factory setting	
-	-	8541[0]	

Description: For the manual mode: Sets the signal source for the speed setpoint.

p8552	IOP speed unit / IOP speed unit		
Access level: 3	Calculated: -	Data type: Integer16	
Can be changed: T	Scaling: -	Dyn. index: -	
Unit group: -	Unit selection: -	Func. diagram: -	
Min	Max	Factory setting	
1	2	2	

Description: Sets the unit for displaying and entering speeds.

Value:
 1: Hz
 2: rpm

p8558	BI: Select IOP manual mode / Sel IOP man mode		
	Access level: 3	Calculated: -	Data type: U32 / Binary
	Can be changed: U, T	Scaling: -	Dyn. index: -
	Unit group: -	Unit selection: -	Func. diagram: -
	Min	Max	Factory setting
	-	-	0

r8559.0...12	CO/BO: Local operator controls status / Local oper status		
	Access level: 3	Calculated: -	Data type: Unsigned32
	Can be changed: -	Scaling: -	Dyn. index: -
	Unit group: -	Unit selection: -	Func. diagram: 2458 2507
	Min	Max	Factory setting
	-	-	-

Description: Display and BICO output for the status of the local operator controls.

Bit field:	Bit	Signal name	1 signal	0 signal	FP
	00	LRC exist	Yes	No	-
	01	Switched off	Yes	No	-
	02	Remote control active	Yes	No	-
	03	Manual mode active	Yes	No	-
	04	Sensor bypass activated	Yes	No	-
	05	Continuous motion activated	Yes	No	-
	06	Jog left active	Yes	No	-
	07	Jog right active	Yes	No	-
	08	LRC not available	Yes	No	-
	10	LRC not detected	Yes	No	-
	11	Drive inhibited	Yes	No	-
	12	Repair switch is on	No	Yes	-

Notice: In the following cases, bit 11 is set and the drive as well as the pulses inhibited:

- when the cover is removed.
- If bit 8 or bit 10 is set.
- If SAM/STARTDRIVE controls the drive and the key-operated switch is brought into the "Manual operation" position. The control from the external source must be enabled in order to withdraw the inhibit.

Bit 12 = 0 (repair switch is switched on or no repair switch available): no maintenance, line voltage on

Bit 12 = 1 (repair switch is switched off): maintenance, line voltage off (0 V)

Note: LRC: Local Remote Control

r8570[0...39]	Macro drive object / Macro DO		
	Access level: 1	Calculated: -	Data type: Unsigned32
	Can be changed: -	Scaling: -	Dyn. index: -
	Unit group: -	Unit selection: -	Func. diagram: -
	Min	Max	Factory setting
	-	-	-

Description: Displays the macro file saved in the appropriate directory on the memory card/device memory.

Dependency: Refer to: p0015

Note: For a value = 9999999, the following applies: The read operation is still running.

r8571[0...39]	Macro Binector Input (BI) / Macro BI		
	Access level: 4	Calculated: -	Data type: Unsigned32
	Can be changed: -	Scaling: -	Dyn. index: -
	Unit group: -	Unit selection: -	Func. diagram: -
	Min	Max	Factory setting
	-	-	-

Description: Displays the ACX file saved in the appropriate directory in the non-volatile memory.

Note: For a value = 9999999, the following applies: The read operation is still running.

r8572[0...39]	Macro Connector Inputs (CI) for speed setpoints / Macro CI n_set		
Access level: 4	Calculated: -	Data type: Unsigned32	
Can be changed: -	Scaling: -	Dyn. index: -	
Unit group: -	Unit selection: -	Func. diagram: -	
Min	Max	Factory setting	
-	-	-	

Description: Displays the ACX file saved in the appropriate directory in the non-volatile memory.

Dependency: Refer to: p1000

Note: For a value = 9999999, the following applies: The read operation is still running.

r8573[0...39]	Macro Connector Inputs (CI) for torque setpoints / Macro CI M_set		
Access level: 4	Calculated: -	Data type: Unsigned32	
Can be changed: -	Scaling: -	Dyn. index: -	
Unit group: -	Unit selection: -	Func. diagram: -	
Min	Max	Factory setting	
-	-	-	

Description: Displays the ACX file saved in the appropriate directory in the non-volatile memory.

Dependency: Refer to: p1500

Note: For a value = 9999999, the following applies: The read operation is still running.

r8585	Macro execution actual / Macro executed		
Access level: 3	Calculated: -	Data type: Unsigned16	
Can be changed: -	Scaling: -	Dyn. index: -	
Unit group: -	Unit selection: -	Func. diagram: -	
Min	Max	Factory setting	
-	-	-	

Description: Displays the macro currently being executed on the drive object.

Dependency: Refer to: p0015, p1000, p1500, r8570, r8571, r8572, r8573

p8598	BI: LRC jog bit 0 / LRC jog bit 0		
Access level: 3	Calculated: -	Data type: U32 / Binary	
Can be changed: T	Scaling: -	Dyn. index: -	
Unit group: -	Unit selection: -	Func. diagram: 2507	
Min	Max	Factory setting	
-	-	8559.7	

Description: Sets the signal source for jog, bit 0.

As default, the following BICO interconnections are available for jog:

BI: p8598 = r8559.7 (jog right active)

BI: p8599 = r8559.6 (jog left active)

If the effect of buttons "Jog left" and "Jog right" are interchanged, then these BICO interconnections should be changed.

Dependency: Refer to: p0840, p1058

Note: LRC: Local Remote Control

p8599	BI: LRC jog bit 1 / LRC jog bit 1		
	Access level: 3	Calculated: -	Data type: U32 / Binary
	Can be changed: T	Scaling: -	Dyn. index: -
	Unit group: -	Unit selection: -	Func. diagram: 2507
	Min	Max	Factory setting
	-	-	8559.6
Description:	Sets the signal source for jog, bit 1. As default, the following BICO interconnections are available for jog: BI: p8598 = r8559.7 (jog right active) BI: p8599 = r8559.6 (jog left active) If the effect of buttons "Jog left" and "Jog right" are interchanged, then these BICO interconnections should be changed.		
Dependency:	Refer to: p0840, p1059		
Note:	LRC: Local Remote Control		

p8805	Identification and maintenance 4 configuration / I&M 4 config		
G115D PN	Access level: 3	Calculated: -	Data type: Integer16
	Can be changed: U, T	Scaling: -	Dyn. index: -
	Unit group: -	Unit selection: -	Func. diagram: -
	Min	Max	Factory setting
	0	1	0
Description:	Sets the configuration for the content of identification and maintenance 4 (I&M 4, p8809).		
Value:	0: Standard value for I&M 4 (p8809) 1: User value for I&M 4 (p8809)		
Dependency:	For p8805 = 0, if the user writes at least one value in p8809[0...53], then p8805 is automatically set to = 1. When p8805 is reset = 0, then the content of the factory setting is set in p8809.		
Note:	For p8805 = 0: PROFINET I&M 4 (p8809) contains the information for the SI change tracking. For p8805 = 1: PROFINET I&M 4 (p8809) contains the values written by the user.		

p8806[0...53]	Identification and Maintenance 1 / I&M 1		
G115D PN	Access level: 3	Calculated: -	Data type: Unsigned8
	Can be changed: U, T	Scaling: -	Dyn. index: -
	Unit group: -	Unit selection: -	Func. diagram: -
	Min	Max	Factory setting
	-	-	
Description:	Parameters for the PROFINET data set "Identification and Maintenance 1" (I&M 1). This information is known as "System identifier" and "Location identifier".		
Dependency:	Refer to: p8807, p8808		
Notice:	Only characters belonging to the standard ASCII character set may be used (32 dec to 126 dec).		
Note:	An ASCII table (excerpt) can be found, for example, in the appendix to the List Manual. For p8806[0...31]: System identifier. For p8806[32...53]: Location identifier.		

p8807[0...15]	Identification and Maintenance 2 / I&M 2		
G115D PN	Access level: 3	Calculated: -	Data type: Unsigned8
	Can be changed: U, T	Scaling: -	Dyn. index: -
	Unit group: -	Unit selection: -	Func. diagram: -
	Min	Max	Factory setting
	-	-	
Description:	Parameters for the PROFINET data set "Identification and Maintenance 2" (I&M 2). This information is known as "Installation date".		
Dependency:	Refer to: p8806, p8808		
Note:	An ASCII table (excerpt) can be found, for example, in the appendix to the List Manual. For p8807[0...15]: Dates of installation or first commissioning of the device with the following format options (ASCII): YYYY-MM-DD or YYYY-MM-DD hh:mm - YYYY: year - MM: month 01 ... 12 - DD: day 01 ... 31 - hh: hours 00 ... 23 - mm: minutes 00 ... 59 Separators must be placed between the individual data, i.e. a hyphen '-', space ' ' and colon ':'.		

p8808[0...53]	Identification and Maintenance 3 / I&M 3		
G115D PN	Access level: 3	Calculated: -	Data type: Unsigned8
	Can be changed: U, T	Scaling: -	Dyn. index: -
	Unit group: -	Unit selection: -	Func. diagram: -
	Min	Max	Factory setting
	-	-	
Description:	Parameters for the PROFINET data set "Identification and Maintenance 3" (I&M 3). This information is known as "Supplementary information".		
Dependency:	Refer to: p8806, p8807		
Notice:	Only characters belonging to the standard ASCII character set may be used (32 dec to 126 dec).		
Note:	An ASCII table (excerpt) can be found, for example, in the appendix to the List Manual. For p8808[0...53]: Any supplementary information and comments (ASCII).		

p8809[0...53]	Identification and Maintenance 4 / I&M 4		
G115D PN	Access level: 3	Calculated: -	Data type: Unsigned8
	Can be changed: U, T	Scaling: -	Dyn. index: -
	Unit group: -	Unit selection: -	Func. diagram: -
	Min	Max	Factory setting
	0000 bin	1111 1111 bin	0000 bin
Description:	Parameters for the PROFINET data set "Identification and Maintenance 4" (I&M 4). This information is known as "Signature".		
Dependency:	This parameter is preassigned as standard (see note). After writing information to p8809, p8805 is automatically set to = 1. Refer to: p8805		

2 Parameters

2.2 List of parameters

Note: For p8805 = 0 (factory setting) the following applies:
Parameter p8809 contains the information described below.
For p8809[0...3]:
Contains the value from r9781[0] "SI change tracking checksum functional".
For p8809[4...7]:
Contains the value from r9782[0] "SI change tracking time stamp checksum functional".
For p8809[8...53]:
Reserved.

r8854	PROFINET state / PN state		
G115D PN	Access level: 4	Calculated: -	Data type: Integer16
	Can be changed: -	Scaling: -	Dyn. index: -
	Unit group: -	Unit selection: -	Func. diagram: -
	Min	Max	Factory setting
	0	255	-

Description: State display for PROFINET.

Value: 0: No initialization
1: Fatal fault
2: Initialization
3: Send configuration
4: Receive configuration
5: Non-cyclic communication
6: Cyclic communications but no setpoints (stop/no clock cycle)
255: Cyclic communication

r8858[0...39]	PROFINET read diagnostics channel / PN diag_chan read		
G115D PN	Access level: 4	Calculated: -	Data type: Unsigned16
	Can be changed: -	Scaling: -	Dyn. index: -
	Unit group: -	Unit selection: -	Func. diagram: -
	Min	Max	Factory setting
	-	-	-

Description: Displays the PROFINET diagnostics data.

Note: Only for internal Siemens diagnostics.

r8859[0...7]	PROFINET identification data / PN ident data		
G115D PN	Access level: 3	Calculated: -	Data type: Unsigned16
	Can be changed: -	Scaling: -	Dyn. index: -
	Unit group: -	Unit selection: -	Func. diagram: -
	Min	Max	Factory setting
	-	-	-

Description: Displays the PROFINET identification data

Index: [0] = Version interface structure
[1] = Version interface driver
[2] = Company (Siemens = 42)
[3] = CB type
[4] = Firmware version
[5] = Firmware date (year)
[6] = Firmware date (day/month)
[7] = Firmware patch/hot fix

Note: Example:
 r8859[0] = 100 --> version of the interface structure V1.00
 r8859[1] = 111 --> version of the interface driver V1.11
 r8859[2] = 42 --> SIEMENS
 r8859[3] = 0
 r8859[4] = 1300 --> first part, firmware version V13.00 (second part, see index 7)
 r8859[5] = 2011 --> year 2011
 r8859[6] = 2306 --> 23rd of June
 r8859[7] = 1700 --> second part, firmware version (complete version: V13.00.17.00)

r8909	PN device ID / PN device ID		
G115D PN	Access level: 3	Calculated: -	Data type: Unsigned16
	Can be changed: -	Scaling: -	Dyn. index: -
	Unit group: -	Unit selection: -	Func. diagram: -
	Min	Max	Factory setting
	-	-	-

Description: Displays the PROFINET Device ID.
 Every SINAMICS device type has its own PROFINET Device ID and its own PROFINET GSD.

Note: List of the SINAMICS Device IDs:
 0501 hex: S120/S150
 0504 hex: G130/G150
 050A hex: DC MASTER
 050C hex: MV
 050F hex: G120P
 0510 hex: G120C
 0511 hex: G120 CU240E-2
 0512 hex: G120D
 0513 hex: G120 CU250S-2 Vector
 0514 hex: G110M
 0523 hex: G120X
 0529 hex: G115D

p8920[0...239]	PN Name of Station / PN Name Stat		
G115D PN	Access level: 3	Calculated: -	Data type: Unsigned8
	Can be changed: U, T	Scaling: -	Dyn. index: -
	Unit group: -	Unit selection: -	Func. diagram: -
	Min	Max	Factory setting
	-	-	-

Description: Sets the station name for the onboard PROFINET interface on the Control Unit.
 The actual station name is displayed in r8930.

Dependency: Refer to: p8925, r8930

Note: An ASCII table (excerpt) can be found, for example, in the appendix to the List Manual.
 The interface configuration (p8920 and following) is activated with p8925.
 The parameter is not influenced by setting the factory setting.
 PN: PROFINET

p8921[0...3]	PN IP address / PN IP addr		
G115D PN	Access level: 3	Calculated: -	Data type: Unsigned8
	Can be changed: U, T	Scaling: -	Dyn. index: -
	Unit group: -	Unit selection: -	Func. diagram: -
	Min	Max	Factory setting
	0	255	0

Description: Sets the IP address for the onboard PROFINET interface on the Control Unit.
 The actual IP address is displayed in r8931.

2 Parameters

2.2 List of parameters

Dependency: Refer to: p8925, r8931
Note: The interface configuration (p8920 and following) is activated with p8925.
The parameter is not influenced by setting the factory setting.

p8922[0...3]	PN Default Gateway / PN Def Gateway		
G115D PN	Access level: 3	Calculated: -	Data type: Unsigned8
	Can be changed: U, T	Scaling: -	Dyn. index: -
	Unit group: -	Unit selection: -	Func. diagram: -
	Min	Max	Factory setting
	0	255	0

Description: Sets the default gateway for the onboard PROFINET interface on the Control Unit.
The actual standard gateway is displayed in r8932.

Dependency: Refer to: p8925, r8932
Note: The interface configuration (p8920 and following) is activated with p8925.
The parameter is not influenced by setting the factory setting.

p8923[0...3]	PN Subnet Mask / PN Subnet Mask		
G115D PN	Access level: 3	Calculated: -	Data type: Unsigned8
	Can be changed: U, T	Scaling: -	Dyn. index: -
	Unit group: -	Unit selection: -	Func. diagram: -
	Min	Max	Factory setting
	0	255	0

Description: Sets the subnet mask for the onboard PROFINET interface on the Control Unit.
The actual subnet mask is displayed in r8933.

Dependency: Refer to: p8925, r8933
Note: The interface configuration (p8920 and following) is activated with p8925.
The parameter is not influenced by setting the factory setting.

p8924	PN DHCP Mode / PN DHCP mode		
G115D PN	Access level: 3	Calculated: -	Data type: Integer16
	Can be changed: U, T	Scaling: -	Dyn. index: -
	Unit group: -	Unit selection: -	Func. diagram: -
	Min	Max	Factory setting
	0	3	0

Description: Sets the DHCP mode for the onboard PROFINET interface on the Control Unit.
The actual DHCP mode is displayed in r8934.

Value:
0: DHCP off
2: DHCP on, identification using MAC address
3: DHCP on, identification via name of station

Dependency: Refer to: p8925, r8934
Notice: When the DHCP mode is active (p8924 not equal to 0), then PROFINET communication via this interface is no longer possible! However, the interface can be used by the STARTER/SCOUT commissioning tool.
Note: The interface configuration (p8920 and following) is activated with p8925.
The active DHCP mode is displayed in parameter r8934.
The parameter is not influenced by setting the factory setting.

p8925	Activate PN interface configuration / PN IF config		
G115D PN	Access level: 3	Calculated: -	Data type: Integer16
	Can be changed: U, T	Scaling: -	Dyn. index: -
	Unit group: -	Unit selection: -	Func. diagram: -
	Min	Max	Factory setting
	0	3	0

Description: Setting to activate the interface configuration for the onboard PROFINET interface on the Control Unit.
p8925 is automatically set to 0 at the end of the operation.

Value:	0: No function 1: Reserved 2: Activate and save configuration 3: Delete configuration
Dependency:	Refer to: p8920, p8921, p8922, p8923, p8924
Notice:	When the DHCP mode is active (p8924 > 0), then PROFINET communication via this interface is no longer possible! However, the interface can be used by the STARTER/SCOUT commissioning tool.
Note:	For p8925 = 2: The interface configuration (p8920 and following) is saved and activated after the next POWER ON. For p8925 = 3: The factory setting of the interface configuration is loaded after the next POWER ON.

p8929	PN remote controller number / PN rem ctrl num		
G115D PN	Access level: 3	Calculated: -	Data type: Integer16
	Can be changed: -	Scaling: -	Dyn. index: -
	Unit group: -	Unit selection: -	Func. diagram: -
	Min	Max	Factory setting
	1	2	1
Description:	Sets the number of remote controllers expected for PROFINET onboard. The "Shared Device" functionality is activated with a value = 2. The drive is being accessed by two PROFINET controllers simultaneously: - automation controller (SIMOTION or SIMATIC A-CPU). - safety controller (SIMATIC F-CPU).		
Value:	1: Automation or Safety 2: Automation and Safety		
Notice:	The F CPU may only use PROFIsafe telegrams.		
Note:	Changes only become effective after POWER ON.		

r8930[0...239]	PN Name of Station actual / PN Name Stat act		
G115D PN	Access level: 3	Calculated: -	Data type: Unsigned8
	Can be changed: -	Scaling: -	Dyn. index: -
	Unit group: -	Unit selection: -	Func. diagram: -
	Min	Max	Factory setting
	-	-	-
Description:	Displays the actual station name for the onboard PROFINET interface on the Control Unit.		

r8931[0...3]	PN IP address actual / PN IP addr act		
G115D PN	Access level: 3	Calculated: -	Data type: Unsigned8
	Can be changed: -	Scaling: -	Dyn. index: -
	Unit group: -	Unit selection: -	Func. diagram: -
	Min	Max	Factory setting
	0	255	-
Description:	Displays the actual IP address for the onboard PROFINET interface on the Control Unit.		

r8932[0...3]	PN Default Gateway actual / PN Def Gateway act		
G115D PN	Access level: 3	Calculated: -	Data type: Unsigned8
	Can be changed: -	Scaling: -	Dyn. index: -
	Unit group: -	Unit selection: -	Func. diagram: -
	Min	Max	Factory setting
	0	255	-
Description:	Displays the actual default gateway for the onboard PROFINET interface on the Control Unit.		

r8933[0...3]	PN Subnet Mask actual / PN Subnet Mask act		
G115D PN	Access level: 3	Calculated: -	Data type: Unsigned8
	Can be changed: -	Scaling: -	Dyn. index: -
	Unit group: -	Unit selection: -	Func. diagram: -
	Min	Max	Factory setting
	0	255	-
Description:	Displays the actual subnet mask for the onboard PROFINET interface on the Control Unit.		

r8934	PN DHCP Mode actual / PN DHCP Mode act		
G115D PN	Access level: 3	Calculated: -	Data type: Integer16
	Can be changed: -	Scaling: -	Dyn. index: -
	Unit group: -	Unit selection: -	Func. diagram: -
	Min	Max	Factory setting
	0	3	-
Description:	Displays the actual DHCP mode for the onboard PROFINET interface on the Control Unit.		
Value:	0: DHCP off 2: DHCP on, identification using MAC address 3: DHCP on, identification via name of station		
Notice:	When the DHCP mode is active (parameter value not equal to 0), PROFINET communication via this interface is no longer possible! However, the interface can be used for commissioning tool such as STARTER or SCOUT.		

r8935[0...5]	PN MAC address / PN MAC addr		
G115D PN	Access level: 3	Calculated: -	Data type: Unsigned8
	Can be changed: -	Scaling: -	Dyn. index: -
	Unit group: -	Unit selection: -	Func. diagram: -
	Min	Max	Factory setting
	0000 hex	00FF hex	-
Description:	Displays the MAC address for the onboard PROFINET interface on the Control Unit.		

r8939	PN DAP ID / PN DAP ID		
G115D PN	Access level: 3	Calculated: -	Data type: Unsigned32
	Can be changed: -	Scaling: -	Dyn. index: -
	Unit group: -	Unit selection: -	Func. diagram: -
	Min	Max	Factory setting
	-	-	-
Description:	Displays the PROFINET Device Access Point ID (DAP ID) for the onboard PROFINET interface. The combination of device ID (r8909) and DAP ID uniquely identifies a PROFINET access point.		
Note:	List of the SINAMICS DAP IDs: 20408 hex: CU230P-2 PN /CU240x-2 PN /CU250S-2 PN /G110M PN V4.6 20409 hex: CU230P-2 PN /CU240x-2 PN /CU250S-2 PN /G110M PN /G115D PN V4.7 20508 hex: CU250D-2 PN V4.6 20509 hex: CU250D-2 PN V4.7		

r8960[0...2]	PN subslot controller assignment / PN subslot assign		
G115D PN	Access level: 3	Calculated: -	Data type: Unsigned8
	Can be changed: -	Scaling: -	Dyn. index: -
	Unit group: -	Unit selection: -	Func. diagram: -
	Min	Max	Factory setting
	0	8	-
Description:	Displays the controller assignment of a PROFINET subslot on the actual drive object.		
Index:	[0] = Subslot 2 PROFIsafe [1] = Subslot 3 PZD telegram [2] = Subslot 4 PZD supplementary data		

Dependency: Refer to: r8961, r8962
Note: Example:
 If the parameter contains the value 2 in index [1], then this means that subplot 3 is assigned to controller 2.

r8961[0...3] PN IP Address Remote Controller 1 / IP Addr Rem Ctrl1

G115D PN	Access level: 3	Calculated: -	Data type: Unsigned8
	Can be changed: -	Scaling: -	Dyn. index: -
	Unit group: -	Unit selection: -	Func. diagram: -
	Min	Max	Factory setting
	0	255	-

Description: Displays the IP address of the first PROFINET controller connected with the device via PN onboard.

r8962[0...3] PN IP Address Remote Controller 2 / IP Addr Rem Ctrl2

G115D PN	Access level: 3	Calculated: -	Data type: Unsigned8
	Can be changed: -	Scaling: -	Dyn. index: -
	Unit group: -	Unit selection: -	Func. diagram: -
	Min	Max	Factory setting
	0	255	-

Description: Displays the IP address of the second PROFINET controller connected with the device via PN onboard.

p8980 Ethernet/IP profile / Eth/IP profile

G115D PN	Access level: 3	Calculated: -	Data type: Integer16
	Can be changed: T	Scaling: -	Dyn. index: -
	Unit group: -	Unit selection: -	Func. diagram: 2473
	Min	Max	Factory setting
	0	1	0

Description: Sets the profile for Ethernet/IP.
Value: 0: SINAMICS
 1: ODVA AC/DC
Note: Changes only become effective after POWER ON.
 The parameter is not influenced by setting the factory setting.
 ODVA: Open DeviceNet Vendor Association

p8981 Ethernet/IP ODVA STOP mode / Eth/IP ODVA STOP

G115D PN	Access level: 3	Calculated: -	Data type: Integer16
	Can be changed: T	Scaling: -	Dyn. index: -
	Unit group: -	Unit selection: -	Func. diagram: 2473
	Min	Max	Factory setting
	0	1	0

Description: Sets the STOP mode for the Ethernet/IP ODVA profile (p8980 = 1).
Value: 0: OFF1
 1: OFF2
Dependency: Refer to: p8980
Note: Changes only become effective after POWER ON.
 The parameter is not influenced by setting the factory setting.

p8982 Ethernet/IP ODVA speed scaling / Eth/IP ODVA n scal

G115D PN	Access level: 3	Calculated: -	Data type: Integer16
	Can be changed: T	Scaling: -	Dyn. index: -
	Unit group: -	Unit selection: -	Func. diagram: -
	Min	Max	Factory setting
	123	133	128

Description: Sets the scaling for the speed for Ethernet/IP ODVA profile (p8980 = 1).

2 Parameters

2.2 List of parameters

Value:

123:	32
124:	16
125:	8
126:	4
127:	2
128:	1
129:	0.5
130:	0.25
131:	0.125
132:	0.0625
133:	0.03125

Dependency: Refer to: p8980

Note: Changes only become effective after POWER ON.
The parameter is not influenced by setting the factory setting.

p8983	Ethernet/IP ODVA torque scaling / Eth/IP ODVA M scal		
G115D PN	Access level: 3	Calculated: -	Data type: Integer16
	Can be changed: T	Scaling: -	Dyn. index: -
	Unit group: -	Unit selection: -	Func. diagram: -
	Min	Max	Factory setting
	123	133	128

Description: Sets the scaling for the torque for Ethernet/IP ODVA profile (p8980 = 1).

Value:

123:	32
124:	16
125:	8
126:	4
127:	2
128:	1
129:	0.5
130:	0.25
131:	0.125
132:	0.0625
133:	0.03125

Dependency: Refer to: p8980

Note: Changes only become effective after POWER ON.
The parameter is not influenced by setting the factory setting.

p8991	USB memory access / USB mem acc		
	Access level: 3	Calculated: -	Data type: Integer16
	Can be changed: T	Scaling: -	Dyn. index: -
	Unit group: -	Unit selection: -	Func. diagram: -
	Min	Max	Factory setting
	1	2	1

Description: Selects the storage medium for access via the USB mass storage.

Value:

1:	Memory card
2:	Flash r/w internal

Note: A change only becomes effective after a POWER ON.
The parameter is not influenced by setting the factory setting.

p8999	USB functionality / USB Fct		
	Access level: 4	Calculated: -	Data type: Integer16
	Can be changed: T	Scaling: -	Dyn. index: -
	Unit group: -	Unit selection: -	Func. diagram: -
	Min	Max	Factory setting
	1	3	3

Description: Setting the USB functionality.

Value: 1: USS commissioning via the virtual COM port
2: Only memory access
3: USB commissioning and memory access

Note: COMM: Commissioning.
A change only becomes effective after a POWER ON.
The parameter is not influenced by setting the factory setting.

p9400 Safely remove memory card / Mem_card rem

Access level: 2	Calculated: -	Data type: Integer16
Can be changed: T	Scaling: -	Dyn. index: -
Unit group: -	Unit selection: -	Func. diagram: -
Min	Max	Factory setting
0	100	0

Description: Setting and display when memory card is "removed safely".
Procedure:
Setting p9400 = 2 results in a value of 3
--> The memory card can be removed safely. After removal the value sets itself to 0 automatically.
Setting p9400 = 2 results in a value of 100
--> The memory card cannot be removed safely as the card is presently being accessed. Removal may destroy the file system on the memory card. It may be necessary to set p9400 = 2 again.

Value: 0: No memory card inserted
1: Memory card inserted
2: Request "safe removal" of the memory card
3: "Safe removal" possible
100: "Safe removal" not possible due to access

Dependency: Refer to: r9401

Notice: Removing the memory card without a request (p9400 = 2) and confirmation (p9400 = 3) may destroy the file system on the memory card. The memory card will then no longer work properly and must be replaced.

Note: The status when the memory card is being "removed safely" is shown in r9401.
For value = 0, 1, 3, 100:
These values can only be displayed, not set.

r9401.0...3 CO/BO: Safely remove memory card status / Mem_card rem stat

Access level: 2	Calculated: -	Data type: Unsigned16
Can be changed: -	Scaling: -	Dyn. index: -
Unit group: -	Unit selection: -	Func. diagram: -
Min	Max	Factory setting
-	-	-

Description: Displays the status of the memory card.

Bit field:	Bit	Signal name	1 signal	0 signal	FP
	00	Memory card inserted	Yes	No	-
	01	Memory card activated	Yes	No	-
	02	SIEMENS memory card	Yes	No	-
	03	Memory card as USB data storage medium from the PC used	Yes	No	-

Dependency: Refer to: p9400

Note: For bit 01, 00:
Bit 1/0 = 0/0: No memory card inserted (corresponds to p9400 = 0).
Bit 1/0 = 0/1: "Safe removal" possible (corresponds to p9400 = 3).
Bit 1/0 = 1/0: Status not possible.
Bit 1/0 = 1/1: Memory card inserted (corresponds to p9400 = 1, 2, 100).
For bit 02, 00:
Bit 2/0 = 0/0: No memory card inserted.
Bit 2/0 = 0/1: Memory card inserted, but not a SIEMENS memory card.
Bit 2/0 = 1/0: Status not possible.
Bit 2/0 = 1/1: SIEMENS memory card inserted.

r9406[0...19]	PS file parameter number parameter not transferred / PS par_no n transf		
	Access level: 4	Calculated: -	Data type: Unsigned16
	Can be changed: -	Scaling: -	Dyn. index: -
	Unit group: -	Unit selection: -	Func. diagram: -
	Min	Max	Factory setting
	-	-	-
Description:	<p>Displays the parameters that were not able to be transferred when reading the parameter back-up files (PS files) from the non-volatile memory (e.g. memory card).</p> <p>r9406[0] = 0</p> <p>--> All of the parameter values were able to be transferred error-free.</p> <p>r9406[0...x] > 0</p> <p>--> indicates the parameter number in the following cases:</p> <ul style="list-style-type: none"> - parameter, whose value was not able to be completely accepted. - indexed parameter, where at least 1 index was not able to be accepted. The first index that is not transferred is displayed in r9407. 		
Dependency:	Refer to: r9407, r9408		
Note:	<p>All indices from r9406 to r9408 designate the same parameter.</p> <p>r9406[x] parameter number, parameter not accepted</p> <p>r9407[x] parameter index, parameter not accepted</p> <p>r9408[x] fault code, parameter not accepted</p>		
r9407[0...19]	PS file parameter index parameter not transferred / PS parameter index		
	Access level: 4	Calculated: -	Data type: Unsigned16
	Can be changed: -	Scaling: -	Dyn. index: -
	Unit group: -	Unit selection: -	Func. diagram: -
	Min	Max	Factory setting
	-	-	-
Description:	<p>Displays the first index of the parameters that could not be transferred when the parameter backup files (PS files) were read from the non-volatile memory (e.g. memory card).</p> <p>If, from an indexed parameter, at least one index was not able to be transferred, then the parameter number is displayed in r9406[n] and the first index that was not transferred is displayed in r9407[n].</p> <p>r9406[0] = 0</p> <p>--> All of the parameter values were able to be transferred error-free.</p> <p>r9406[n] > 0</p> <p>--> Displays r9407[n] the first index of the parameter number r9406[n] that was not transferred.</p>		
Dependency:	Refer to: r9406, r9408		
Note:	<p>All indices from r9406 to r9408 designate the same parameter.</p> <p>r9406[x] parameter number, parameter not accepted</p> <p>r9407[x] parameter index, parameter not accepted</p> <p>r9408[x] fault code, parameter not accepted</p>		
r9408[0...19]	PS file fault code parameter not transferred / PS fault code		
	Access level: 4	Calculated: -	Data type: Unsigned16
	Can be changed: -	Scaling: -	Dyn. index: -
	Unit group: -	Unit selection: -	Func. diagram: -
	Min	Max	Factory setting
	-	-	-
Description:	Only for internal Siemens service purposes.		
Dependency:	Refer to: r9406, r9407		
Note:	<p>All indices from r9406 to r9408 designate the same parameter.</p> <p>r9406[x] parameter number, parameter not accepted</p> <p>r9407[x] parameter index, parameter not accepted</p> <p>r9408[x] fault code, parameter not accepted</p>		

r9409	Number of parameters to be saved / Qty par to save		
	Access level: 4	Calculated: -	Data type: Unsigned16
	Can be changed: -	Scaling: -	Dyn. index: -
	Unit group: -	Unit selection: -	Func. diagram: -
	Min	Max	Factory setting
	-	-	-
Description:	Displays the number of modified parameters and those that have still not be saved for this drive object.		
Dependency:	Refer to: p0971		
Notice:	Inherent to the system, the list of the parameters to be backed up is empty after the following actions: - Download - Warm restart - Factory setting In these cases, a new parameter backup must be initiated, which is then the starting point for the list of modified parameters.		
Note:	The modified parameters that still need to be saved are internally listed in r9410 ... r9419.		
r9451[0...29]	Units changeover adapted parameters / Unit_chngov par		
	Access level: 4	Calculated: -	Data type: Unsigned32
	Can be changed: -	Scaling: -	Dyn. index: -
	Unit group: -	Unit selection: -	Func. diagram: -
	Min	Max	Factory setting
	-	-	-
Description:	Displays the parameters whose parameter would have to be changed during a units changeover.		
Dependency:	Refer to: F07088		
r9463	Actual macro / Actual macro		
	Access level: 3	Calculated: -	Data type: Unsigned32
	Can be changed: -	Scaling: -	Dyn. index: -
	Unit group: -	Unit selection: -	Func. diagram: -
	Min	Max	Factory setting
	0	999999	-
Description:	Displays the set valid macro.		
Note:	A value of 0 is displayed if a parameter set by a macro is changed.		
p9484	BICO interconnections search signal source / BICO s_s srch		
	Access level: 3	Calculated: -	Data type: Unsigned32
	Can be changed: U, T	Scaling: -	Dyn. index: -
	Unit group: -	Unit selection: -	Func. diagram: -
	Min	Max	Factory setting
	0	4294967295	0
Description:	Sets the signal source (BO/CO parameter, BICO coded) to search in the signal sinks. The signal source to be searched for is set in p9484 (BICO-coded) and the search result is specified using the number (r9485) and the first index (r9486).		
Dependency:	Refer to: r9485, r9486		
r9485	BICO interconnections signal source search count / BICO s_s srch qty		
	Access level: 3	Calculated: -	Data type: Unsigned16
	Can be changed: -	Scaling: -	Dyn. index: -
	Unit group: -	Unit selection: -	Func. diagram: -
	Min	Max	Factory setting
	-	-	-
Description:	Displays the number of BICO interconnections to the signal sink being searched for.		

2 Parameters

2.2 List of parameters

Dependency: Refer to: p9484, r9486
Note: The signal source to be searched is set in p9484 (BICO-coded).
 The search result is contained in r9482 and r9483 and is specified by the count (r9485) and the first index (r9486).

r9486	BICO interconnections signal source search first index / BICO s_s srch Idx		
	Access level: 3	Calculated: -	Data type: Unsigned16
	Can be changed: -	Scaling: -	Dyn. index: -
	Unit group: -	Unit selection: -	Func. diagram: -
	Min	Max	Factory setting
	-	-	-

Description: Displays the first index of the signal source being searched for.
 The signal source to be searched for is set in p9484 (BICO-coded) and the search result is specified using the number (r9485) and the first index (r9486).

Dependency: Refer to: p9484, r9485
Note: The signal source to be searched is set in p9484 (BICO-coded).
 The search result is contained in r9482 and r9483 and is specified by the count (r9485) and the first index (r9486).

p9601	SI enable functions integrated in the drive (processor 1) / SI enable fct P1		
G115D I/O	Access level: 3	Calculated: -	Data type: Unsigned32
G115D ASI	Can be changed: C(95)	Scaling: -	Dyn. index: -
	Unit group: -	Unit selection: -	Func. diagram: -
	Min	Max	Factory setting
	-	-	0000 bin

Description: Sets the enable signals for the safety functions integrated in the drive and the type of selection on processor 1.
 Not all of the settings listed below will be permissible, depending on the Control Unit being used:
 0000 hex:
 Safety functions integrated in the drive inhibited (no safety function).
 0001 hex:
 Basic functions are enabled via onboard terminals (permissible for r9771.0 = 1).
 0008 hex:
 Basic functions are enabled via PROFIsafe (permissible for r9771.6 = 1).
 0009 hex:
 Basic functions are enabled via PROFIsafe onboard terminals (permissible for r9771.6 = 1).

Bit field:	Bit	Signal name	1 signal	0 signal	FP
	00	Enable STO via terminals (processor 1)	Enable	Inhibit	2810

Dependency: Refer to: r9771, p9801
Note: A change always becomes effective only after a POWER ON. Exception: Changes to p9601.0 become effective immediately.
 STO: Safe Torque Off

p9601		SI enable functions integrated in the drive (processor 1) / SI enable fct P1			
G115D PN	Access level: 3	Calculated: -	Data type: Unsigned32		
	Can be changed: C(95)	Scaling: -	Dyn. index: -		
	Unit group: -	Unit selection: -	Func. diagram: -		
	Min	Max	Factory setting		
	-	-	0000 bin		
Description:	Sets the enable signals for the safety functions integrated in the drive and the type of selection on processor 1. Not all of the settings listed below will be permissible, depending on the Control Unit being used: 0000 hex: Safety functions integrated in the drive inhibited (no safety function). 0001 hex: Basic functions are enabled via onboard terminals (permissible for r9771.0 = 1). 0008 hex: Basic functions are enabled via PROFIsafe (permissible for r9771.6 = 1). 0009 hex: Basic functions are enabled via PROFIsafe onboard terminals (permissible for r9771.6 = 1).				
Bit field:	Bit	Signal name	1 signal	0 signal	FP
	00	Enable STO via terminals (processor 1)	Enable	Inhibit	2810
	03	Enable PROFIsafe (processor 1)	Enable	Inhibit	-
Dependency:	Refer to: r9771, p9801				
Note:	A change always becomes effective only after a POWER ON. Exception: Changes to p9601.0 become effective immediately. STO: Safe Torque Off				

p9610		SI PROFIsafe address (processor 1) / SI PROFIsafe P1		
G115D PN	Access level: 3	Calculated: -	Data type: Unsigned16	
	Can be changed: C(95)	Scaling: -	Dyn. index: -	
	Unit group: -	Unit selection: -	Func. diagram: -	
	Min	Max	Factory setting	
	0000 hex	FFFE hex	0000 hex	
Description:	Sets the PROFIsafe address for processor 1.			
Dependency:	Refer to: p9810			

p9650		SI F-DI changeover discrepancy time (processor 1) / SI F-DI chg t P1		
	Access level: 3	Calculated: -	Data type: FloatingPoint32	
	Can be changed: C(95)	Scaling: -	Dyn. index: -	
	Unit group: -	Unit selection: -	Func. diagram: 2810	
	Min	Max	Factory setting	
	0.00 [ms]	2000.00 [ms]	500.00 [ms]	
Description:	Sets the discrepancy time for the changeover of the Failsafe Digital Input for STO on processor 1. An F-DI changeover is not effective simultaneously due to the different runtimes in the two monitoring channels. After an F-DI changeover, dynamic data is not subject to a data cross-check during this discrepancy time.			
Dependency:	Refer to: p9850			
Note:	For a data cross-check between p9650 and p9850, a difference of one Safety monitoring clock cycle is tolerated. The set time is rounded internally to an integer multiple of the monitoring clock cycle. F-DI: Failsafe Digital Input			

p9651	SI STO debounce time (processor 1) / SI STO t_debou P1		
	Access level: 3	Calculated: -	Data type: FloatingPoint32
	Can be changed: C(95)	Scaling: -	Dyn. index: -
	Unit group: -	Unit selection: -	Func. diagram: -
	Min	Max	Factory setting
	0.00 [ms]	100.00 [ms]	1.00 [ms]
Description:	Sets the debounce time for the Failsafe Digital Inputs used to control the "STO" function. The debounce time is rounded to whole milliseconds.		
Note:	The debounce time is rounded to whole milliseconds. It specifies the maximum duration of a fault pulse at the Failsafe Digital Inputs with no reaction/influence on the selection or deselection of the Safety Basic Functions. Example: Debounce time = 1 ms: Fault pulses of 1 ms are filtered; only pulses longer than 2 ms are processed. Debounce time = 3 ms: Fault pulses of 3 ms are filtered; only pulses longer than 4 ms are processed.		
p9659	SI forced checking procedure timer / SI FCP Timer		
	Access level: 3	Calculated: -	Data type: FloatingPoint32
	Can be changed: C(95)	Scaling: -	Dyn. index: -
	Unit group: -	Unit selection: -	Func. diagram: 2810
	Min	Max	Factory setting
	0.00 [h]	9000.00 [h]	8.00 [h]
Description:	Sets the time interval for carrying out the forced checking procedure and testing the Safety switch-off signal paths. Within the parameterized time, STO must have been de-selected at least once. The monitoring time is reset each time that STO is de-selected.		
Dependency:	Refer to: A01699		
Note:	STO: Safe Torque Off		
r9660	SI forced checking procedure remaining time / SI FCP remain		
	Access level: 3	Calculated: -	Data type: FloatingPoint32
	Can be changed: -	Scaling: -	Dyn. index: -
	Unit group: -	Unit selection: -	Func. diagram: -
	Min	Max	Factory setting
	- [h]	- [h]	- [h]
Description:	Displays the time remaining before dynamization and testing of the safety switch-off signal paths (forced checking procedure).		
Dependency:	Refer to: A01699		
p9670	SI module identification Control Unit / Module ID CU		
	Access level: 3	Calculated: -	Data type: Unsigned32
	Can be changed: T	Scaling: -	Dyn. index: -
	Unit group: -	Unit selection: -	Func. diagram: -
	Min	Max	Factory setting
	0	4294967295	0
Description:	CRC via Node Identifier of the Control Unit.		
Note:	CU: Control Unit		
p9672	SI module identifier Power Module / Module ID PM		
	Access level: 3	Calculated: -	Data type: Unsigned32
	Can be changed: T	Scaling: -	Dyn. index: -
	Unit group: -	Unit selection: -	Func. diagram: -
	Min	Max	Factory setting
	0	4294967295	0
Description:	CRC via the Node Identifier of a Power Module.		

Note: PM: Power Module

p9700	SI Motion copy function / SI Mtn copy fct		
	Access level: 3	Calculated: -	Data type: Integer16
	Can be changed: U, T	Scaling: -	Dyn. index: -
	Unit group: -	Unit selection: -	Func. diagram: -
	Min	Max	Factory setting
	0000 hex	00D0 hex	0000 hex
Description:	Setting to start the required copy function. After starting, the corresponding parameters are copied from processor 1 to processor 2. Once copying is complete, the parameter is automatically reset to zero.		
Value:	0: [00 hex] Copy function ended 208: [D0 hex] Start copy function SI basic parameters		
Note:	For value = D0 hex: The value can only be set if the safety commissioning mode is set and the Safety Integrated password was entered. The following parameters are copied after starting the copy function: p9601 --> p9801, p9610 --> 9810, p9650 --> p9850, p9651 --> p9851		

p9701	Acknowledge SI motion data change / Ackn SI Mtn dat		
	Access level: 3	Calculated: -	Data type: Integer16
	Can be changed: U, T	Scaling: -	Dyn. index: -
	Unit group: -	Unit selection: -	Func. diagram: -
	Min	Max	Factory setting
	0000 hex	00DC hex	0000 hex
Description:	Setting to transfer the reference checksums from the associated actual checksums after changes (SI parameters, hardware). After transferring the reference checksums, parameters are automatically reset to zero.		
Value:	0: [00 hex] Data unchanged 220: [DC hex] Acknowledge SI basic parameter change		
Dependency:	Refer to: r9798, p9799, r9898, p9899		
Note:	For value = DC hex: The value can only be set if the safety commissioning mode is set and the Safety Integrated password was entered.		

p9761	SI password input / SI password inp		
	Access level: 3	Calculated: -	Data type: Unsigned32
	Can be changed: C, T	Scaling: -	Dyn. index: -
	Unit group: -	Unit selection: -	Func. diagram: 2800
	Min	Max	Factory setting
	0000 hex	FFFF FFFF hex	0000 hex
Description:	Enters the Safety Integrated password.		
Dependency:	Refer to: F01659		
Note:	It is not possible to change Safety Integrated parameters until the Safety Integrated password has been entered.		

p9762	SI password new / SI password new		
	Access level: 3	Calculated: -	Data type: Unsigned32
	Can be changed: C(95)	Scaling: -	Dyn. index: -
	Unit group: -	Unit selection: -	Func. diagram: 2800
	Min	Max	Factory setting
	0000 hex	FFFF FFFF hex	0000 hex
Description:	Enters a new Safety Integrated password.		
Dependency:	A change made to the Safety Integrated password must be acknowledged in the following parameter: Refer to: p9763		

p9763	SI password acknowledgment / SI ackn password		
	Access level: 3	Calculated: -	Data type: Unsigned32
	Can be changed: C(95)	Scaling: -	Dyn. index: -
	Unit group: -	Unit selection: -	Func. diagram: 2800
	Min	Max	Factory setting
	0000 hex	FFFF FFFF hex	0000 hex
Description:	Acknowledges the new Safety Integrated password.		
Dependency:	Refer to: p9762		
Note:	The new password entered into p9762 must be re-entered in order to acknowledge. p9762 = p9763 = 0 is automatically set after the new Safety Integrated password has been successfully acknowledged.		
r9768[0...7]	SI PROFIsafe receive control words (processor 1) / SI Ps PZD recv P1		
G115D PN	Access level: 3	Calculated: -	Data type: Unsigned16
	Can be changed: -	Scaling: -	Dyn. index: -
	Unit group: -	Unit selection: -	Func. diagram: -
	Min	Max	Factory setting
	-	-	-
Description:	Displays the received PROFIsafe telegram on processor 1.		
Index:	[0] = PZD 1 [1] = PZD 2 [2] = PZD 3 [3] = PZD 4 [4] = PZD 5 [5] = PZD 6 [6] = PZD 7 [7] = PZD 8		
Dependency:	Refer to: r9769		
Note:	The PROFIsafe trailer at the end of the telegram is also displayed (2 words).		
r9769[0...7]	SI PROFIsafe send status words (processor 1) / SI Ps PZD send P1		
G115D PN	Access level: 3	Calculated: -	Data type: Unsigned16
	Can be changed: -	Scaling: -	Dyn. index: -
	Unit group: -	Unit selection: -	Func. diagram: -
	Min	Max	Factory setting
	-	-	-
Description:	Displays the PROFIsafe telegram to be sent on processor 1.		
Index:	[0] = PZD 1 [1] = PZD 2 [2] = PZD 3 [3] = PZD 4 [4] = PZD 5 [5] = PZD 6 [6] = PZD 7 [7] = PZD 8		
Dependency:	Refer to: r9768		
Note:	The PROFIsafe trailer at the end of the telegram is also displayed (2 words).		
r9770[0...3]	SI version drive-integrated safety function (processor 1) / SI version Drv P1		
	Access level: 3	Calculated: -	Data type: Unsigned16
	Can be changed: -	Scaling: -	Dyn. index: -
	Unit group: -	Unit selection: -	Func. diagram: 2802
	Min	Max	Factory setting
	-	-	-
Description:	Displays the Safety Integrated version for the drive-integrated safety functions on processor 1.		

Index: [0] = Safety Version (major release)
 [1] = Safety Version (minor release)
 [2] = Safety Version (baselevel or patch)
 [3] = Safety Version (hotfix)

Note: Example:
 r9770[0] = 2, r9770[1] = 60, r9770[2] = 1, r9770[3] = 0 --> Safety version V02.60.01.00

r9771	SI common functions (processor 1) / SI general fct P1				
G115D I/O	Access level: 3	Calculated: -	Data type: Unsigned32		
G115D ASI	Can be changed: -	Scaling: -	Dyn. index: -		
	Unit group: -	Unit selection: -	Func. diagram: 2804		
	Min	Max	Factory setting		
	-	-	-		
Description:	Displays the supported Safety Integrated monitoring functions. Processor 1 determines this display.				
Bit field:	Bit	Signal name	1 signal	0 signal	FP
	00	STO supported via terminals	Yes	No	2804
Dependency:	Refer to: r9871				
Note:	STO: Safe Torque Off				

r9771	SI common functions (processor 1) / SI general fct P1				
G115D PN	Access level: 3	Calculated: -	Data type: Unsigned32		
	Can be changed: -	Scaling: -	Dyn. index: -		
	Unit group: -	Unit selection: -	Func. diagram: 2804		
	Min	Max	Factory setting		
	-	-	-		
Description:	Displays the supported Safety Integrated monitoring functions. Processor 1 determines this display.				
Bit field:	Bit	Signal name	1 signal	0 signal	FP
	00	STO supported via terminals	Yes	No	2804
	06	Basic Functions PROFIsafe supported	Yes	No	-
Dependency:	Refer to: r9871				
Note:	STO: Safe Torque Off				

r9772.0...21	CO/BO: SI status (processor 1) / SI status P1				
G115D I/O	Access level: 2	Calculated: -	Data type: Unsigned32		
G115D ASI	Can be changed: -	Scaling: -	Dyn. index: -		
	Unit group: -	Unit selection: -	Func. diagram: 2804		
	Min	Max	Factory setting		
	-	-	-		
Description:	Displays the Safety Integrated status on processor 1.				
Bit field:	Bit	Signal name	1 signal	0 signal	FP
	00	STO selected on processor 1	Yes	No	2810
	01	STO active on processor 1	Yes	No	2810
	07	STO terminal state on processor 1 (Basic Functions)	High	Low	-
	09	STOP A cannot be acknowledged active	Yes	No	2802
	10	STOP A active	Yes	No	2802
	15	STOP F active	Yes	No	2802
	16	STO cause: Safety comm. mode	Yes	No	-
	17	STO cause selection via terminal (Basic Functions)	Yes	No	-
	21	STO cause selection on the other monitoring channel	Yes	No	-
Dependency:	Refer to: r9872				

r9772.0...21	CO/BO: SI status (processor 1) / SI status P1				
G115D PN	Access level: 2	Calculated: -	Data type: Unsigned32		
	Can be changed: -	Scaling: -	Dyn. index: -		
	Unit group: -	Unit selection: -	Func. diagram: 2804		
	Min	Max	Factory setting		
	-	-	-		
Description:	Displays the Safety Integrated status on processor 1.				
Bit field:	Bit	Signal name	1 signal	0 signal	FP
	00	STO selected on processor 1	Yes	No	2810
	01	STO active on processor 1	Yes	No	2810
	07	STO terminal state on processor 1 (Basic Functions)	High	Low	-
	09	STOP A cannot be acknowledged active	Yes	No	2802
	10	STOP A active	Yes	No	2802
	15	STOP F active	Yes	No	2802
	16	STO cause: Safety comm. mode	Yes	No	-
	17	STO cause selection via terminal (Basic Functions)	Yes	No	-
	20	STO cause selection PROFIsafe (Basic Functions)	Yes	No	-
	21	STO cause selection on the other monitoring channel	Yes	No	-
Dependency:	Refer to: r9872				

r9773.0...31	CO/BO: SI status (processor 1 + processor 2) / SI status P1+P2				
	Access level: 2	Calculated: -	Data type: Unsigned32		
	Can be changed: -	Scaling: -	Dyn. index: -		
	Unit group: -	Unit selection: -	Func. diagram: 2804		
	Min	Max	Factory setting		
	-	-	-		
Description:	Display and BICO output for the Safety Integrated status on the drive (processor 1 + processor 2).				
Bit field:	Bit	Signal name	1 signal	0 signal	FP
	00	STO selected in drive	Yes	No	2804
	01	STO active in drive	Yes	No	2804
	31	Test stop required for STO	Yes	No	2810
Note:	This status is formed from the AND operation of the relevant status of the two monitoring channels.				

r9776	SI diagnostics / SI diag				
	Access level: 3	Calculated: -	Data type: Unsigned32		
	Can be changed: -	Scaling: -	Dyn. index: -		
	Unit group: -	Unit selection: -	Func. diagram: -		
	Min	Max	Factory setting		
	-	-	-		
Description:	The parameter is used for diagnostics.				
Bit field:	Bit	Signal name	1 signal	0 signal	FP
	00	Safety parameter changed POWER ON required	Yes	No	-
	01	Safety functions enabled	Yes	No	-
	02	Safety component replaced and data save required	Yes	No	-
	03	Safety component replaced and acknowledge/save required	Yes	No	-

Note: For bit 00 = 1:
At least one Safety parameter has been changed that will only take effect after a POWER ON.
For bit 01 = 1:
Safety functions (basic functions or extended functions) have been enabled and are active.
For bit 02 = 1:
A safety-relevant component has been replaced. Data save required (p0977 = 1 or p0971 = 1 or "copy RAM to ROM").
For bit 03 = 1:
A safety-relevant component has been replaced. Acknowledge (p9702 = 29) and save (p0977 = 1 or p0971 = 1 or "Copy RAM to ROM") required.

r9780	SI monitoring clock cycle (processor 1) / SI mon_clk cyc P1		
	Access level: 3	Calculated: -	Data type: FloatingPoint32
	Can be changed: -	Scaling: -	Dyn. index: -
	Unit group: -	Unit selection: -	Func. diagram: 2802
	Min	Max	Factory setting
	- [ms]	- [ms]	- [ms]
Description:	Displays the clock cycle time for the Safety Integrated Basic Functions on processor 1.		
Note:	Information regarding the relationship between monitoring clock cycle and response times can be found in the following references: - SINAMICS G120 Function Manual Safety Integrated - technical documentation for the particular product		

r9781[0...1]	SI checksum to check changes (processor 1) / SI chg chksm P1		
	Access level: 3	Calculated: -	Data type: Unsigned32
	Can be changed: -	Scaling: -	Dyn. index: -
	Unit group: -	Unit selection: -	Func. diagram: -
	Min	Max	Factory setting
	-	-	-
Description:	Displays the checksum for tracking changes for Safety Integrated. These are additional checksums that are created to track changes (fingerprint for the "safety logbook" functionality) to safety parameters (that are relevant for checksums).		
Index:	[0] = SI checksum to track functional changes [1] = SI checksum to track hardware-specific changes		
Dependency:	Refer to: p9601, p9799 Refer to: F01690		

r9782[0...1]	SI time stamp to check changes (processor 1) / SI chg t P1		
	Access level: 3	Calculated: -	Data type: FloatingPoint32
	Can be changed: -	Scaling: -	Dyn. index: -
	Unit group: -	Unit selection: -	Func. diagram: -
	Min	Max	Factory setting
	- [h]	- [h]	- [h]
Description:	Displays the time stamps for the checksums for tracking changes for Safety Integrated. The time stamps for the checksums for tracking changes (fingerprint for the "safety logbook" functionality) made to safety parameters are saved in parameters p9781[0] and p9781[1].		
Index:	[0] = SI time stamp for checksum to track functional changes [1] = SI time stamp for checksum to track hardware-specific changes		
Dependency:	Refer to: p9601, p9799 Refer to: F01690		

r9794[0...19]	SI cross-check list (processor 1) / SI KDV_list P1		
	Access level: 3	Calculated: -	Data type: Unsigned16
	Can be changed: -	Scaling: -	Dyn. index: -
	Unit group: -	Unit selection: -	Func. diagram: 2802
	Min	Max	Factory setting
	-	-	-
Description:	Displays the numbers of the data items that are currently being cross-checked on processor 1. The content of the list of cross-checked data is dependent upon the particular application.		
Note:	Example: r9794[0] = 1 (monitoring clock cycle) r9794[1] = 2 (enable safety functions) r9794[2] = 3 (F-DI changeover, tolerance time) ... A complete list of numbers for cross-checked data items appears in fault F01611.		
r9795	SI diagnostics STOP F (processor 1) / SI diag STOP F P1		
	Access level: 2	Calculated: -	Data type: Unsigned32
	Can be changed: -	Scaling: -	Dyn. index: -
	Unit group: -	Unit selection: -	Func. diagram: 2802
	Min	Max	Factory setting
	-	-	-
Description:	Displays the number of the cross-checked data item which caused STOP F on processor 1.		
Dependency:	Refer to: F01611		
Note:	A complete list of numbers for cross-checked data items appears in fault F01611.		
r9798	SI actual checksum SI parameters (processor 1) / SI act chksm P1		
	Access level: 3	Calculated: -	Data type: Unsigned32
	Can be changed: -	Scaling: -	Dyn. index: -
	Unit group: -	Unit selection: -	Func. diagram: 2800
	Min	Max	Factory setting
	-	-	-
Description:	Displays the checksum for the Safety Integrated parameters checked using checksums on processor 1 (actual checksum).		
Dependency:	Refer to: p9799, r9898		
p9799	SI reference checksum SI parameters (processor 1) / SI setp_chksm P1		
	Access level: 3	Calculated: -	Data type: Unsigned32
	Can be changed: C(95)	Scaling: -	Dyn. index: -
	Unit group: -	Unit selection: -	Func. diagram: 2800
	Min	Max	Factory setting
	0000 hex	FFFF FFFF hex	0000 hex
Description:	Sets the checksum for the Safety Integrated parameters checked using checksums on processor 1 (reference checksum).		
Dependency:	Refer to: r9798, p9899		

p9801		SI enable functions integrated in the drive (processor 2) / SI enable fct P2			
G115D I/O	Access level: 3	Calculated: -	Data type: Unsigned16		
G115D ASI	Can be changed: C(95)	Scaling: -	Dyn. index: -		
	Unit group: -	Unit selection: -	Func. diagram: -		
	Min	Max	Factory setting		
	-	-	0000 bin		
Description:	Sets the enable signals for the safety functions integrated in the drive and the type of selection on processor 2. Not all of the settings listed below will be permissible, depending on the Control Unit being used: 0000 hex: Safety functions integrated in the drive inhibited (no safety function). 0001 hex: Basic functions are enabled via onboard terminals (permissible for r9771.0 = 1). 0008 hex: Basic functions are enabled via PROFIsafe (permissible for r9771.6 = 1). 0009 hex: Basic functions are enabled via PROFIsafe onboard terminals (permissible for r9771.6 = 1).				
Bit field:	Bit	Signal name	1 signal	0 signal	FP
	00	Enable STO via terminals (processor 2)	Enable	Inhibit	2810
Dependency:	Refer to: p9601, r9871				
Notice:	This parameter is overwritten by the copy function of the safety functions integrated in the drive.				
Note:	A change always becomes effective only after a POWER ON. Exception: Changes to p9801.0 become effective immediately. STO: Safe Torque Off				

p9801		SI enable functions integrated in the drive (processor 2) / SI enable fct P2			
G115D PN	Access level: 3	Calculated: -	Data type: Unsigned16		
	Can be changed: C(95)	Scaling: -	Dyn. index: -		
	Unit group: -	Unit selection: -	Func. diagram: -		
	Min	Max	Factory setting		
	-	-	0000 bin		
Description:	Sets the enable signals for the safety functions integrated in the drive and the type of selection on processor 2. Not all of the settings listed below will be permissible, depending on the Control Unit being used: 0000 hex: Safety functions integrated in the drive inhibited (no safety function). 0001 hex: Basic functions are enabled via onboard terminals (permissible for r9771.0 = 1). 0008 hex: Basic functions are enabled via PROFIsafe (permissible for r9771.6 = 1). 0009 hex: Basic functions are enabled via PROFIsafe onboard terminals (permissible for r9771.6 = 1).				
Bit field:	Bit	Signal name	1 signal	0 signal	FP
	00	Enable STO via terminals (processor 2)	Enable	Inhibit	2810
	03	Enable PROFIsafe (processor 2)	Enable	Inhibit	-
Dependency:	Refer to: p9601, r9871				
Notice:	This parameter is overwritten by the copy function of the safety functions integrated in the drive.				
Note:	A change always becomes effective only after a POWER ON. Exception: Changes to p9801.0 become effective immediately. STO: Safe Torque Off				

2 Parameters

2.2 List of parameters

p9810	SI PROFIsafe address (processor 2) / SI PROFIsafe P2			
G115D PN	Access level: 3	Calculated: -	Data type: Unsigned16	
	Can be changed: C(95)	Scaling: -	Dyn. index: -	
	Unit group: -	Unit selection: -	Func. diagram: -	
	Min	Max	Factory setting	
	0000 hex	FFFE hex	0000 hex	
Description:	Sets the PROFIsafe address on processor 2.			
Notice:	This parameter is overwritten by the copy function of the safety functions integrated in the drive.			
p9850	SI F-DI changeover discrepancy time (processor 2) / SI F-DI chg t P2			
	Access level: 3	Calculated: -	Data type: FloatingPoint32	
	Can be changed: C(95)	Scaling: -	Dyn. index: -	
	Unit group: -	Unit selection: -	Func. diagram: 2810	
	Min	Max	Factory setting	
	0.00 [µs]	2000000.00 [µs]	500000.00 [µs]	
Description:	Sets the discrepancy time for the changeover of the Failsafe Digital Input for STO on processor 2. An F-DI changeover is not effective simultaneously due to the different runtimes in the two monitoring channels. After an F-DI changeover, dynamic data is not subject to a data cross-check during this discrepancy time.			
Dependency:	Refer to: p9650			
Notice:	This parameter is overwritten by the copy function of the safety functions integrated in the drive.			
Note:	For a data cross-check between p9650 and p9850, a difference of one Safety monitoring clock cycle is tolerated. The set time is rounded internally to an integer multiple of the monitoring clock cycle. F-DI: Failsafe Digital Input			
p9851	SI STO debounce time (processor 2) / SI STO t_debou P2			
	Access level: 3	Calculated: -	Data type: FloatingPoint32	
	Can be changed: C(95)	Scaling: -	Dyn. index: -	
	Unit group: -	Unit selection: -	Func. diagram: -	
	Min	Max	Factory setting	
	0.00 [µs]	100000.00 [µs]	0.00 [µs]	
Description:	Sets the debounce time for the Failsafe Digital Inputs used to control the "STO" function. The debounce time is rounded to whole milliseconds.			
Dependency:	Refer to: p9651			
Notice:	This parameter is overwritten by the copy function of the safety functions integrated in the drive.			
Note:	Rounding effects can occur in the last decimal place of the parameterized time. The debounce time is rounded to whole milliseconds. It specifies the maximum duration of a fault pulse at the Failsafe Digital Inputs with no reaction/influence on the selection or deselection of the Safety Basic Functions. Example: Debounce time = 1 ms: Fault pulses of 1 ms are filtered; only pulses longer than 2 ms are processed. Debounce time = 3 ms: Fault pulses of 3 ms are filtered; only pulses longer than 4 ms are processed.			
r9871	SI common functions (processor 2) / SI common fct P2			
G115D I/O	Access level: 3	Calculated: -	Data type: Unsigned32	
G115D ASI	Can be changed: -	Scaling: -	Dyn. index: -	
	Unit group: -	Unit selection: -	Func. diagram: 2804	
	Min	Max	Factory setting	
	-	-	-	
Description:	Displays the supported Safety Integrated monitoring functions. Processor 2 determines this display.			
Bit field:	Bit	Signal name	1 signal	0 signal
	00	STO supported via terminals	Yes	No
Dependency:	Refer to: r9771			
Note:	STO: Safe Torque Off			

r9871		SI common functions (processor 2) / SI common fct P2			
G115D PN	Access level: 3	Calculated: -	Data type: Unsigned32		
	Can be changed: -	Scaling: -	Dyn. index: -		
	Unit group: -	Unit selection: -	Func. diagram: 2804		
	Min	Max	Factory setting		
	-	-	-		
Description:	Displays the supported Safety Integrated monitoring functions. Processor 2 determines this display.				
Bit field:	Bit	Signal name	1 signal	0 signal	FP
	00	STO supported via terminals	Yes	No	2804
	06	Basic Functions PROFIsafe supported	Yes	No	-
Dependency:	Refer to: r9771				
Note:	STO: Safe Torque Off				

r9872.0...21		CO/BO: SI status (processor 1) / SI status P1			
G115D I/O	Access level: 2	Calculated: -	Data type: Unsigned32		
G115D ASI	Can be changed: -	Scaling: -	Dyn. index: -		
	Unit group: -	Unit selection: -	Func. diagram: 2804		
	Min	Max	Factory setting		
	-	-	-		
Description:	Displays the Safety Integrated status on processor 2.				
Bit field:	Bit	Signal name	1 signal	0 signal	FP
	00	STO selected on processor 2	Yes	No	2810
	01	STO active on processor 2	Yes	No	2810
	07	STO terminal state on processor 2 (Basic Functions)	High	Low	-
	09	STOP A cannot be acknowledged active	Yes	No	2802
	10	STOP A active	Yes	No	2802
	15	STOP F active	Yes	No	2802
	16	STO cause: Safety comm. mode	Yes	No	-
	17	STO cause selection via terminal (Basic Functions)	Yes	No	-
	21	STO cause selection on the other monitoring channel	Yes	No	-
Dependency:	Refer to: r9772				

r9872.0...21		CO/BO: SI status (processor 1) / SI status P1			
G115D PN	Access level: 2	Calculated: -	Data type: Unsigned32		
	Can be changed: -	Scaling: -	Dyn. index: -		
	Unit group: -	Unit selection: -	Func. diagram: 2804		
	Min	Max	Factory setting		
	-	-	-		
Description:	Displays the Safety Integrated status on processor 2.				
Bit field:	Bit	Signal name	1 signal	0 signal	FP

2 Parameters

2.2 List of parameters

00	STO selected on processor 2	Yes	No	2810
01	STO active on processor 2	Yes	No	2810
07	STO terminal state on processor 2 (Basic Functions)	High	Low	-
09	STOP A cannot be acknowledged active	Yes	No	2802
10	STOP A active	Yes	No	2802
15	STOP F active	Yes	No	2802
16	STO cause: Safety comm. mode	Yes	No	-
17	STO cause selection via terminal (Basic Functions)	Yes	No	-
20	STO cause selection PROFIsafe (Basic Functions)	Yes	No	-
21	STO cause selection on the other monitoring channel	Yes	No	-

Dependency: Refer to: r9772

p9897 **SI Motion bus failure STO delay time (MM) / SI Mtn Pc t_del MM**

Access level: 3	Calculated: -	Data type: FloatingPoint32
Can be changed: C(95)	Scaling: -	Dyn. index: -
Unit group: -	Unit selection: -	Func. diagram: -
Min	Max	Factory setting
0.00 [µs]	800000.00 [µs]	0.00 [µs]

Description: Sets the delay time for STO after bus failure on the Motor Module/Hydraulic Module (e.g. used for ESR).

Notice: This parameter is overwritten by the copy function of the safety functions integrated in the drive.

Note: Rounding effects can occur in the last decimal place of the parameterized time. The set time is rounded internally to an integer multiple of the monitoring clock cycle.

ESR: Extended Stop and Retract

STO: Safe Torque Off / SH: Safe standstill

r9898 **SI actual checksum SI parameters (processor 2) / SI act_chksm P2**

Access level: 3	Calculated: -	Data type: Unsigned32
Can be changed: -	Scaling: -	Dyn. index: -
Unit group: -	Unit selection: -	Func. diagram: 2800
Min	Max	Factory setting
-	-	-

Description: Displays the checksum for the Safety Integrated parameters checked using checksums on processor 2 (actual checksum).

Dependency: Refer to: r9798, p9899

p9899 **SI reference checksum SI parameters (processor 2) / SI setp_chksm P2**

Access level: 3	Calculated: -	Data type: Unsigned32
Can be changed: C(95)	Scaling: -	Dyn. index: -
Unit group: -	Unit selection: -	Func. diagram: 2800
Min	Max	Factory setting
0000 hex	FFFF FFFF hex	0000 hex

Description: Sets the checksum for the Safety Integrated parameters checked using checksums on processor 2 (reference checksum).

Dependency: Refer to: p9799, r9898

r9925[0...99] **Firmware file incorrect / FW file incorr**

Access level: 3	Calculated: -	Data type: Unsigned8
Can be changed: -	Scaling: -	Dyn. index: -
Unit group: -	Unit selection: -	Func. diagram: -
Min	Max	Factory setting
-	-	-

Description: Displays the directory and name of the file whose status as shipped from the factory was identified as impermissible.

Dependency: Refer to: r9926
Refer to: A01016

Note: The directory and name of the file is displayed in the ASCII code.

r9926	Firmware check status / FW check status		
Access level: 3	Calculated: -	Data type: Unsigned8	
Can be changed: -	Scaling: -	Dyn. index: -	
Unit group: -	Unit selection: -	Func. diagram: -	
Min	Max	Factory setting	
-	-	-	

Description: Displays the status when the firmware is checked when the system is booted.
0: Firmware not yet checked.
1: Check running.
2: Check successfully completed.
3: Check indicates an error.

Dependency: Refer to: r9925
Refer to: A01016

p9930[0...8]	System logbook activation / SYSLOG activation		
Access level: 4	Calculated: -	Data type: Unsigned8	
Can be changed: U, T	Scaling: -	Dyn. index: -	
Unit group: -	Unit selection: -	Func. diagram: -	
Min	Max	Factory setting	
0	255	0	

Description: Only for service purposes.

Index: [0] = System logbook stage (0: Not active)
[1] = COM2/COM1 (0: COM2, 1: COM1)
[2] = Activate file write (0: Not active)
[3] = Display time stamp (0: Not displayed)
[4...7] = Reserved
[8] = System logbook file size (stages, each 10 kB)

Notice: Before switching off the Control Unit, ensure that the system logbook is switched out (p9930[0] = 0).
If writing to the file is activated (p9930[2] = 1), writing to the file must be deactivated again before switching off the Control Unit (p9930[2] = 0) in order to ensure that the system logbook has been completely written to the file.

p9931[0...180]	System logbook module selection / SYSLOG mod select.		
Access level: 4	Calculated: -	Data type: Unsigned32	
Can be changed: U, T	Scaling: -	Dyn. index: -	
Unit group: -	Unit selection: -	Func. diagram: -	
Min	Max	Factory setting	
0000 hex	FFFF FFFF hex	0000 hex	

Description: Only for service purposes.

p9932	Save system logbook EEPROM / SYSLOG EEPROM save		
Access level: 4	Calculated: -	Data type: Unsigned8	
Can be changed: U, T	Scaling: -	Dyn. index: -	
Unit group: -	Unit selection: -	Func. diagram: -	
Min	Max	Factory setting	
0	255	0	

Description: Only for service purposes.

r9935.0	BO: POWER ON delay signal / POWER ON t_delay			
	Access level: 4	Calculated: -	Data type: Unsigned8	
	Can be changed: -	Scaling: -	Dyn. index: -	
	Unit group: -	Unit selection: -	Func. diagram: -	
	Min	Max	Factory setting	
	-	-	-	
Description:	Display and binector output for a delay after POWER ON. After switch-on, binector output r9935.0 is set with the start of the first sampling time and is again reset after approx. 100 ms.			
Bit field:	Bit	Signal name	1 signal	0 signal
	00	POWER ON delay signal	High	Low
				FP
				-

r9975[0...7]	System utilization measured / Sys util meas			
	Access level: 4	Calculated: -	Data type: FloatingPoint32	
	Can be changed: -	Scaling: -	Dyn. index: -	
	Unit group: -	Unit selection: -	Func. diagram: -	
	Min	Max	Factory setting	
	- [%]	- [%]	- [%]	
Description:	Displays the measured system utilization. The higher the value displayed, the higher the system utilization.			
Index:	[0] = Computing time utilization (min) [1] = Computing time utilization (averaged) [2] = Computing time utilization (max) [3] = Largest total utilization (min) [4] = Largest total utilization (averaged) [5] = Largest total utilization (max) [6] = Reserved [7] = Reserved			
Dependency:	Refer to: r9976 Refer to: F01054, F01205			
Note:	For index [3 ... 5]: The total utilizations are determined using all sampling times used. The largest total utilizations are mapped here. The sampling time with the largest total utilization is displayed in r9979. Total utilization: Computing time load of sampling time involved including load from higher-priority sampling times (interrupts).			

r9976[0...7]	System utilization / Sys util			
	Access level: 3	Calculated: -	Data type: FloatingPoint32	
	Can be changed: -	Scaling: -	Dyn. index: -	
	Unit group: -	Unit selection: -	Func. diagram: -	
	Min	Max	Factory setting	
	- [%]	- [%]	- [%]	
Description:	Displays the system utilization. If the utilization is greater than 100%, fault F01054 is output.			
Index:	[0] = Reserved [1] = Computing time utilization [2] = Reserved [3] = Reserved [4] = Reserved [5] = Largest total utilization [6] = Reserved [7] = Reserved			
Dependency:	Refer to: F01054, F01205			

Note: For index [1]:
The value shows the total computing time load of the system.
For index [5]:
The total utilization is determined using all sampling times used. The largest total utilization is mapped here. The sampling time with the largest total utilization is displayed in r9979.
Total utilization:
Computing time load of sampling time involved including load from higher-priority sampling times (interrupts).

r9999[0...99]	Software error internal supplementary diagnostics / SW_err int diag		
Access level: 4	Calculated: -	Data type: Unsigned32	
Can be changed: -	Scaling: -	Dyn. index: -	
Unit group: -	Unit selection: -	Func. diagram: -	
Min	Max	Factory setting	
-	-	-	

Description: Diagnostics parameter to display additional information for internal software errors.
Note: Only for internal Siemens troubleshooting.

r20001[0...9]	Runtime group sampling time / RTG sampling time		
Access level: 3	Calculated: -	Data type: FloatingPoint32	
Can be changed: -	Scaling: -	Dyn. index: -	
Unit group: -	Unit selection: -	Func. diagram: -	
Min	Max	Factory setting	
- [ms]	- [ms]	- [ms]	

Description: Displays the current sampling time of the runtime group 0 to 9.

Index:
[0] = Runtime group 0
[1] = Runtime group 1
[2] = Runtime group 2
[3] = Runtime group 3
[4] = Runtime group 4
[5] = Runtime group 5
[6] = Runtime group 6
[7] = Runtime group 7
[8] = Runtime group 8
[9] = Runtime group 9

p20030[0...3]	BI: AND 0 inputs / AND 0 inputs		
Access level: 3	Calculated: -	Data type: U32 / Binary	
Can be changed: T	Scaling: -	Dyn. index: -	
Unit group: -	Unit selection: -	Func. diagram: 7210	
Min	Max	Factory setting	
-	-	0	

Description: Sets the signal source of input quantities I0, I1, I2, I3 of instance AND 0 of the AND function block.

Index:
[0] = Input I0
[1] = Input I1
[2] = Input I2
[3] = Input I3

r20031	BO: AND 0 output Q / AND 0 output Q		
Access level: 3	Calculated: -	Data type: Unsigned32	
Can be changed: -	Scaling: -	Dyn. index: -	
Unit group: -	Unit selection: -	Func. diagram: 7210	
Min	Max	Factory setting	
-	-	-	

Description: Display parameter for binary quantity Q = I0 & I1 & I2 & I3 of instance AND 0 of the AND function block.

p20032	AND 0 runtime group / AND 0 RTG		
	Access level: 3	Calculated: -	Data type: Integer16
	Can be changed: T	Scaling: -	Dyn. index: -
	Unit group: -	Unit selection: -	Func. diagram: 7210
	Min	Max	Factory setting
	1	9999	9999
Description:	Setting parameter for the runtime group in which the instance AND 0 of the AND function block is to be called.		
Value:	1: Runtime group 1 2: Runtime group 2 3: Runtime group 3 4: Runtime group 4 5: Runtime group 5 6: Runtime group 6 9999: Do not calculate		
p20033	AND 0 run sequence / AND 0 RunSeq		
	Access level: 3	Calculated: -	Data type: Unsigned16
	Can be changed: T	Scaling: -	Dyn. index: -
	Unit group: -	Unit selection: -	Func. diagram: 7210
	Min	Max	Factory setting
	0	32000	10
Description:	Setting parameter for the run sequence of instance AND 0 within the runtime group set in p20032.		
Note:	The function blocks with a lower run sequence value are calculated before function blocks with a higher run sequence value.		
p20034[0...3]	BI: AND 1 inputs / AND 1 inputs		
	Access level: 3	Calculated: -	Data type: U32 / Binary
	Can be changed: T	Scaling: -	Dyn. index: -
	Unit group: -	Unit selection: -	Func. diagram: 7210
	Min	Max	Factory setting
	-	-	0
Description:	Sets the signal source of input quantities I0, I1, I2, I3 of instance AND 1 of the AND function block.		
Index:	[0] = Input I0 [1] = Input I1 [2] = Input I2 [3] = Input I3		
r20035	BO: AND 1 output Q / AND 1 output Q		
	Access level: 3	Calculated: -	Data type: Unsigned32
	Can be changed: -	Scaling: -	Dyn. index: -
	Unit group: -	Unit selection: -	Func. diagram: 7210
	Min	Max	Factory setting
	-	-	-
Description:	Display parameter for binary quantity Q = I0 & I1 & I2 & I3 of instance AND 1 of the AND function block.		
p20036	AND 1 runtime group / AND 1 RTG		
	Access level: 3	Calculated: -	Data type: Integer16
	Can be changed: T	Scaling: -	Dyn. index: -
	Unit group: -	Unit selection: -	Func. diagram: 7210
	Min	Max	Factory setting
	1	9999	9999
Description:	Setting parameter for the runtime group in which the instance AND 1 of the AND function block is to be called.		

Value:	1: Runtime group 1
	2: Runtime group 2
	3: Runtime group 3
	4: Runtime group 4
	5: Runtime group 5
	6: Runtime group 6
	9999: Do not calculate

p20037	AND 1 run sequence / AND 1 RunSeq		
	Access level: 3	Calculated: -	Data type: Unsigned16
	Can be changed: T	Scaling: -	Dyn. index: -
	Unit group: -	Unit selection: -	Func. diagram: 7210
	Min	Max	Factory setting
	0	32000	20

Description: Setting parameter for the run sequence of instance AND 1 within the runtime group set in p20036.

Note: The function blocks with a lower run sequence value are calculated before function blocks with a higher run sequence value.

p20038[0...3]	BI: AND 2 inputs / AND 2 inputs		
	Access level: 3	Calculated: -	Data type: U32 / Binary
	Can be changed: T	Scaling: -	Dyn. index: -
	Unit group: -	Unit selection: -	Func. diagram: 7210
	Min	Max	Factory setting
	-	-	0

Description: Sets the signal source of input quantities I0, I1, I2, I3 of instance AND 2 of the AND function block.

Index:
 [0] = Input I0
 [1] = Input I1
 [2] = Input I2
 [3] = Input I3

r20039	BO: AND 2 output Q / AND 2 output Q		
	Access level: 3	Calculated: -	Data type: Unsigned32
	Can be changed: -	Scaling: -	Dyn. index: -
	Unit group: -	Unit selection: -	Func. diagram: 7210
	Min	Max	Factory setting
	-	-	-

Description: Display parameter for binary quantity Q = I0 & I1 & I2 & I3 of instance AND 2 of the AND function block.

p20040	AND 2 runtime group / AND 2 RTG		
	Access level: 3	Calculated: -	Data type: Integer16
	Can be changed: T	Scaling: -	Dyn. index: -
	Unit group: -	Unit selection: -	Func. diagram: 7210
	Min	Max	Factory setting
	1	9999	9999

Description: Setting parameter for the runtime group in which the instance AND 2 of the AND function block is to be called.

Value:	1: Runtime group 1
	2: Runtime group 2
	3: Runtime group 3
	4: Runtime group 4
	5: Runtime group 5
	6: Runtime group 6
	9999: Do not calculate

p20041	AND 2 run sequence / AND 2 RunSeq		
	Access level: 3	Calculated: -	Data type: Unsigned16
	Can be changed: T	Scaling: -	Dyn. index: -
	Unit group: -	Unit selection: -	Func. diagram: 2710
	Min	Max	Factory setting
	0	32000	30
Description:	Setting parameter for the run sequence of instance AND 2 within the runtime group set in p20040.		
Note:	The function blocks with a lower run sequence value are calculated before function blocks with a higher run sequence value.		
p20042[0...3]	BI: AND 3 inputs / AND 3 inputs		
	Access level: 3	Calculated: -	Data type: U32 / Binary
	Can be changed: T	Scaling: -	Dyn. index: -
	Unit group: -	Unit selection: -	Func. diagram: 7210
	Min	Max	Factory setting
	-	-	0
Description:	Sets the signal source of input quantities I0, I1, I2, I3 of instance AND 3 of the AND function block.		
Index:	[0] = Input I0 [1] = Input I1 [2] = Input I2 [3] = Input I3		
r20043	BO: AND 3 output Q / AND 3 output Q		
	Access level: 3	Calculated: -	Data type: Unsigned32
	Can be changed: -	Scaling: -	Dyn. index: -
	Unit group: -	Unit selection: -	Func. diagram: 7210
	Min	Max	Factory setting
	-	-	-
Description:	Display parameter for binary quantity Q = I0 & I1 & I2 & I3 of instance AND 3 of the AND function block.		
p20044	AND 3 runtime group / AND 3 RTG		
	Access level: 3	Calculated: -	Data type: Integer16
	Can be changed: T	Scaling: -	Dyn. index: -
	Unit group: -	Unit selection: -	Func. diagram: 7210
	Min	Max	Factory setting
	1	9999	9999
Description:	Setting parameter for the runtime group in which the instance AND 3 of the AND function block is to be called.		
Value:	1: Runtime group 1 2: Runtime group 2 3: Runtime group 3 4: Runtime group 4 5: Runtime group 5 6: Runtime group 6 9999: Do not calculate		
p20045	AND 3 run sequence / AND 3 RunSeq		
	Access level: 3	Calculated: -	Data type: Unsigned16
	Can be changed: T	Scaling: -	Dyn. index: -
	Unit group: -	Unit selection: -	Func. diagram: 7210
	Min	Max	Factory setting
	0	32000	40
Description:	Setting parameter for the run sequence of instance AND 3 within the runtime group set in p20044.		
Note:	The function blocks with a lower run sequence value are calculated before function blocks with a higher run sequence value.		

p20046[0...3]	BI: OR 0 inputs / OR 0 inputs		
	Access level: 3	Calculated: -	Data type: U32 / Binary
	Can be changed: T	Scaling: -	Dyn. index: -
	Unit group: -	Unit selection: -	Func. diagram: 7212
	Min	Max	Factory setting
	-	-	0
Description:	Sets the signal source of input quantities I0, I1, I2, I3 of instance OR 0 of the OR function block.		
Index:	[0] = Input I0 [1] = Input I1 [2] = Input I2 [3] = Input I3		
r20047	BO: OR 0 output Q / OR 0 output Q		
	Access level: 3	Calculated: -	Data type: Unsigned32
	Can be changed: -	Scaling: -	Dyn. index: -
	Unit group: -	Unit selection: -	Func. diagram: 7212
	Min	Max	Factory setting
	-	-	-
Description:	Display parameter for binary quantity Q = I0 I1 I2 I3 of instance OR 0 of the OR function block.		
p20048	OR 0 runtime group / OR 0 RTG		
	Access level: 3	Calculated: -	Data type: Integer16
	Can be changed: T	Scaling: -	Dyn. index: -
	Unit group: -	Unit selection: -	Func. diagram: 7212
	Min	Max	Factory setting
	1	9999	9999
Description:	Setting parameter for the runtime group in which the instance OR 0 of the OR function block is to be called.		
Value:	1: Runtime group 1 2: Runtime group 2 3: Runtime group 3 4: Runtime group 4 5: Runtime group 5 6: Runtime group 6 9999: Do not calculate		
p20049	OR 0 run sequence / OR 0 RunSeq		
	Access level: 3	Calculated: -	Data type: Unsigned16
	Can be changed: T	Scaling: -	Dyn. index: -
	Unit group: -	Unit selection: -	Func. diagram: 7212
	Min	Max	Factory setting
	0	32000	60
Description:	Setting parameter for the run sequence of instance OR 0 within the runtime group set in p20048.		
Note:	The function blocks with a lower run sequence value are calculated before function blocks with a higher run sequence value.		
p20050[0...3]	BI: OR 1 inputs / OR 1 inputs		
	Access level: 3	Calculated: -	Data type: U32 / Binary
	Can be changed: T	Scaling: -	Dyn. index: -
	Unit group: -	Unit selection: -	Func. diagram: 7212
	Min	Max	Factory setting
	-	-	0
Description:	Sets the signal source of input quantities I0, I1, I2, I3 of instance OR 1 of the OR function block.		

2 Parameters

2.2 List of parameters

Index:
 [0] = Input I0
 [1] = Input I1
 [2] = Input I2
 [3] = Input I3

r20051	BO: OR 1 output Q / OR 1 output Q		
	Access level: 3	Calculated: -	Data type: Unsigned32
	Can be changed: -	Scaling: -	Dyn. index: -
	Unit group: -	Unit selection: -	Func. diagram: 7212
	Min	Max	Factory setting
	-	-	-

Description: Display parameter for binary quantity Q = I0 | I1 | I2 | I3 of instance OR 1 of the OR function block.

p20052	OR 1 runtime group / OR 1 RTG		
	Access level: 3	Calculated: -	Data type: Integer16
	Can be changed: T	Scaling: -	Dyn. index: -
	Unit group: -	Unit selection: -	Func. diagram: 7212
	Min	Max	Factory setting
	1	9999	9999

Description: Setting parameter for the runtime group in which the instance OR 1 of the OR function block is to be called.

Value:
 1: Runtime group 1
 2: Runtime group 2
 3: Runtime group 3
 4: Runtime group 4
 5: Runtime group 5
 6: Runtime group 6
 9999: Do not calculate

p20053	OR 1 run sequence / OR 1 RunSeq		
	Access level: 3	Calculated: -	Data type: Unsigned16
	Can be changed: T	Scaling: -	Dyn. index: -
	Unit group: -	Unit selection: -	Func. diagram: 7212
	Min	Max	Factory setting
	0	32000	70

Description: Setting parameter for the run sequence of instance OR 1 within the runtime group set in p20052.

Note: The function blocks with a lower run sequence value are calculated before function blocks with a higher run sequence value.

p20054[0...3]	BI: OR 2 inputs / OR 2 inputs		
	Access level: 3	Calculated: -	Data type: U32 / Binary
	Can be changed: T	Scaling: -	Dyn. index: -
	Unit group: -	Unit selection: -	Func. diagram: 7212
	Min	Max	Factory setting
	-	-	0

Description: Sets the signal source of input quantities I0, I1, I2, I3 of instance OR 2 of the OR function block.

Index:
 [0] = Input I0
 [1] = Input I1
 [2] = Input I2
 [3] = Input I3

r20055	BO: OR 2 output Q / OR 2 output Q		
	Access level: 3	Calculated: -	Data type: Unsigned32
	Can be changed: -	Scaling: -	Dyn. index: -
	Unit group: -	Unit selection: -	Func. diagram: 7212
	Min	Max	Factory setting
	-	-	-
Description:	Display parameter for binary quantity Q = I0 I1 I2 I3 of instance OR 2 of the OR function block.		
p20056	OR 2 runtime group / OR 2 RTG		
	Access level: 3	Calculated: -	Data type: Integer16
	Can be changed: T	Scaling: -	Dyn. index: -
	Unit group: -	Unit selection: -	Func. diagram: 7212
	Min	Max	Factory setting
	1	9999	9999
Description:	Setting parameter for the runtime group in which the instance OR 2 of the OR function block is to be called.		
Value:	1: Runtime group 1 2: Runtime group 2 3: Runtime group 3 4: Runtime group 4 5: Runtime group 5 6: Runtime group 6 9999: Do not calculate		
p20057	OR 2 run sequence / OR 2 RunSeq		
	Access level: 3	Calculated: -	Data type: Unsigned16
	Can be changed: T	Scaling: -	Dyn. index: -
	Unit group: -	Unit selection: -	Func. diagram: 7212
	Min	Max	Factory setting
	0	32000	80
Description:	Setting parameter for the run sequence of instance OR 2 within the runtime group set in p20056.		
Note:	The function blocks with a lower run sequence value are calculated before function blocks with a higher run sequence value.		
p20058[0...3]	BI: OR 3 inputs / OR 3 inputs		
	Access level: 3	Calculated: -	Data type: U32 / Binary
	Can be changed: T	Scaling: -	Dyn. index: -
	Unit group: -	Unit selection: -	Func. diagram: 7212
	Min	Max	Factory setting
	-	-	0
Description:	Sets the signal source of input quantities I0, I1, I2, I3 of instance OR 3 of the OR function block.		
Index:	[0] = Input I0 [1] = Input I1 [2] = Input I2 [3] = Input I3		
r20059	BO: OR 3 output Q / OR 3 output Q		
	Access level: 3	Calculated: -	Data type: Unsigned32
	Can be changed: -	Scaling: -	Dyn. index: -
	Unit group: -	Unit selection: -	Func. diagram: 7212
	Min	Max	Factory setting
	-	-	-
Description:	Display parameter for binary quantity Q = I0 I1 I2 I3 of instance OR 3 of the OR function block.		

p20060	OR 3 runtime group / OR 3 RTG		
	Access level: 3	Calculated: -	Data type: Integer16
	Can be changed: T	Scaling: -	Dyn. index: -
	Unit group: -	Unit selection: -	Func. diagram: 7212
	Min	Max	Factory setting
	1	9999	9999
Description:	Setting parameter for the runtime group in which the instance OR 3 of the OR function block is to be called.		
Value:	1: Runtime group 1 2: Runtime group 2 3: Runtime group 3 4: Runtime group 4 5: Runtime group 5 6: Runtime group 6 9999: Do not calculate		
p20061	OR 3 run sequence / OR 3 RunSeq		
	Access level: 3	Calculated: -	Data type: Unsigned16
	Can be changed: T	Scaling: -	Dyn. index: -
	Unit group: -	Unit selection: -	Func. diagram: 7212
	Min	Max	Factory setting
	0	32000	90
Description:	Setting parameter for the run sequence of instance OR 3 within the runtime group set in p20060.		
Note:	The function blocks with a lower run sequence value are calculated before function blocks with a higher run sequence value.		
p20062[0...3]	BI: XOR 0 inputs / XOR 0 inputs		
	Access level: 3	Calculated: -	Data type: U32 / Binary
	Can be changed: T	Scaling: -	Dyn. index: -
	Unit group: -	Unit selection: -	Func. diagram: 7214
	Min	Max	Factory setting
	-	-	0
Description:	Sets the signal source of input quantities I0, I1, I2, I3 of instance XOR 0 of the XOR function block.		
Index:	[0] = Input I0 [1] = Input I1 [2] = Input I2 [3] = Input I3		
r20063	BO: XOR 0 output Q / XOR 0 output Q		
	Access level: 3	Calculated: -	Data type: Unsigned32
	Can be changed: -	Scaling: -	Dyn. index: -
	Unit group: -	Unit selection: -	Func. diagram: 7214
	Min	Max	Factory setting
	-	-	-
Description:	Display parameter for binary quantity Q of instance XOR 0 of the XOR function block.		
p20064	XOR 0 runtime group / XOR 0 RTG		
	Access level: 3	Calculated: -	Data type: Integer16
	Can be changed: T	Scaling: -	Dyn. index: -
	Unit group: -	Unit selection: -	Func. diagram: 7214
	Min	Max	Factory setting
	1	9999	9999
Description:	Setting parameter for the runtime group in which the instance XOR 0 of the XOR function block is to be called.		

Value:	1: Runtime group 1
	2: Runtime group 2
	3: Runtime group 3
	4: Runtime group 4
	5: Runtime group 5
	6: Runtime group 6
	9999: Do not calculate

p20065	XOR 0 run sequence / XOR 0 RunSeq		
	Access level: 3	Calculated: -	Data type: Unsigned16
	Can be changed: T	Scaling: -	Dyn. index: -
	Unit group: -	Unit selection: -	Func. diagram: 7214
	Min	Max	Factory setting
	0	32000	110

Description: Setting parameter for the run sequence of instance XOR 0 within the runtime group set in p20064.

Note: The function blocks with a lower run sequence value are calculated before function blocks with a higher run sequence value.

p20066[0...3]	BI: XOR 1 inputs / XOR 1 inputs		
	Access level: 3	Calculated: -	Data type: U32 / Binary
	Can be changed: T	Scaling: -	Dyn. index: -
	Unit group: -	Unit selection: -	Func. diagram: 7214
	Min	Max	Factory setting
	-	-	0

Description: Sets the signal source of input quantities I0, I1, I2, I3 of instance XOR 1 of the XOR function block.

Index:
 [0] = Input I0
 [1] = Input I1
 [2] = Input I2
 [3] = Input I3

r20067	BO: XOR 1 output Q / XOR 1 output Q		
	Access level: 3	Calculated: -	Data type: Unsigned32
	Can be changed: -	Scaling: -	Dyn. index: -
	Unit group: -	Unit selection: -	Func. diagram: 7214
	Min	Max	Factory setting
	-	-	-

Description: Display parameter for binary quantity Q of instance XOR 1 of the XOR function block.

p20068	XOR 1 runtime group / XOR 1 RTG		
	Access level: 3	Calculated: -	Data type: Integer16
	Can be changed: T	Scaling: -	Dyn. index: -
	Unit group: -	Unit selection: -	Func. diagram: 7214
	Min	Max	Factory setting
	1	9999	9999

Description: Setting parameter for the runtime group in which the instance XOR 1 of the XOR function block is to be called.

Value:	1: Runtime group 1
	2: Runtime group 2
	3: Runtime group 3
	4: Runtime group 4
	5: Runtime group 5
	6: Runtime group 6
	9999: Do not calculate

p20069	XOR 1 run sequence / XOR 1 RunSeq		
	Access level: 3	Calculated: -	Data type: Unsigned16
	Can be changed: T	Scaling: -	Dyn. index: -
	Unit group: -	Unit selection: -	Func. diagram: 7214
	Min	Max	Factory setting
	0	32000	120
Description:	Setting parameter for the run sequence of instance XOR 1 within the runtime group set in p20068.		
Note:	The function blocks with a lower run sequence value are calculated before function blocks with a higher run sequence value.		
p20070[0...3]	BI: XOR 2 inputs / XOR 2 inputs		
	Access level: 3	Calculated: -	Data type: U32 / Binary
	Can be changed: T	Scaling: -	Dyn. index: -
	Unit group: -	Unit selection: -	Func. diagram: 7214
	Min	Max	Factory setting
	-	-	0
Description:	Sets the signal source of input quantities I0, I1, I2, I3 of instance XOR 2 of the XOR function block.		
Index:	[0] = Input I0 [1] = Input I1 [2] = Input I2 [3] = Input I3		
r20071	BO: XOR 2 output Q / XOR 2 output Q		
	Access level: 3	Calculated: -	Data type: Unsigned32
	Can be changed: -	Scaling: -	Dyn. index: -
	Unit group: -	Unit selection: -	Func. diagram: 7214
	Min	Max	Factory setting
	-	-	-
Description:	Display parameter for binary quantity Q of instance XOR 2 of the XOR function block.		
p20072	XOR 2 runtime group / XOR 2 RTG		
	Access level: 3	Calculated: -	Data type: Integer16
	Can be changed: T	Scaling: -	Dyn. index: -
	Unit group: -	Unit selection: -	Func. diagram: 7214
	Min	Max	Factory setting
	1	9999	9999
Description:	Setting parameter for the runtime group in which the instance XOR 2 of the XOR function block is to be called.		
Value:	1: Runtime group 1 2: Runtime group 2 3: Runtime group 3 4: Runtime group 4 5: Runtime group 5 6: Runtime group 6 9999: Do not calculate		
p20073	XOR 2 run sequence / XOR 2 RunSeq		
	Access level: 3	Calculated: -	Data type: Unsigned16
	Can be changed: T	Scaling: -	Dyn. index: -
	Unit group: -	Unit selection: -	Func. diagram: 7214
	Min	Max	Factory setting
	0	32000	130
Description:	Setting parameter for the run sequence of instance XOR 2 within the runtime group set in p20072.		
Note:	The function blocks with a lower run sequence value are calculated before function blocks with a higher run sequence value.		

p20074[0...3]	BI: XOR 3 inputs / XOR 3 inputs		
	Access level: 3	Calculated: -	Data type: U32 / Binary
	Can be changed: T	Scaling: -	Dyn. index: -
	Unit group: -	Unit selection: -	Func. diagram: 7214
	Min	Max	Factory setting
	-	-	0
Description:	Sets the signal source of input quantities I0, I1, I2, I3 of instance XOR 3 of the XOR function block.		
Index:	[0] = Input I0 [1] = Input I1 [2] = Input I2 [3] = Input I3		
r20075	BO: XOR 3 output Q / XOR 3 output Q		
	Access level: 3	Calculated: -	Data type: Unsigned32
	Can be changed: -	Scaling: -	Dyn. index: -
	Unit group: -	Unit selection: -	Func. diagram: 7214
	Min	Max	Factory setting
	-	-	-
Description:	Display parameter for binary quantity Q of instance XOR 3 of the XOR function block.		
p20076	XOR 3 runtime group / XOR 3 RTG		
	Access level: 3	Calculated: -	Data type: Integer16
	Can be changed: T	Scaling: -	Dyn. index: -
	Unit group: -	Unit selection: -	Func. diagram: 7214
	Min	Max	Factory setting
	1	9999	9999
Description:	Setting parameter for the runtime group in which the instance XOR 3 of the XOR function block is to be called.		
Value:	1: Runtime group 1 2: Runtime group 2 3: Runtime group 3 4: Runtime group 4 5: Runtime group 5 6: Runtime group 6 9999: Do not calculate		
p20077	XOR 3 run sequence / XOR 3 RunSeq		
	Access level: 3	Calculated: -	Data type: Unsigned16
	Can be changed: T	Scaling: -	Dyn. index: -
	Unit group: -	Unit selection: -	Func. diagram: 7214
	Min	Max	Factory setting
	0	32000	140
Description:	Setting parameter for the run sequence of instance XOR 3 within the runtime group set in p20076.		
Note:	The function blocks with a lower run sequence value are calculated before function blocks with a higher run sequence value.		
p20078	BI: NOT 0 input I / NOT 0 input I		
	Access level: 3	Calculated: -	Data type: U32 / Binary
	Can be changed: T	Scaling: -	Dyn. index: -
	Unit group: -	Unit selection: -	Func. diagram: 7216
	Min	Max	Factory setting
	-	-	0
Description:	Sets the signal source of input quantity I of instance NOT 0 of the inverter.		

r20079	BO: NOT 0 inverted output / NOT 0 inv output		
	Access level: 3	Calculated: -	Data type: Unsigned32
	Can be changed: -	Scaling: -	Dyn. index: -
	Unit group: -	Unit selection: -	Func. diagram: 7216
	Min	Max	Factory setting
	-	-	-
Description:	Display parameter for the inverted output of instance NOT 0 of the inverter.		
p20080	NOT 0 runtime group / NOT 0 RTG		
	Access level: 3	Calculated: -	Data type: Integer16
	Can be changed: T	Scaling: -	Dyn. index: -
	Unit group: -	Unit selection: -	Func. diagram: 7216
	Min	Max	Factory setting
	1	9999	9999
Description:	Setting parameter for the runtime group in which the instance NOT 0 of the inverter is to be called.		
Value:	1: Runtime group 1 2: Runtime group 2 3: Runtime group 3 4: Runtime group 4 5: Runtime group 5 6: Runtime group 6 9999: Do not calculate		
p20081	NOT 0 run sequence / NOT 0 RunSeq		
	Access level: 3	Calculated: -	Data type: Unsigned16
	Can be changed: T	Scaling: -	Dyn. index: -
	Unit group: -	Unit selection: -	Func. diagram: 7216
	Min	Max	Factory setting
	0	32000	160
Description:	Setting parameter for the run sequence of instance NOT 0 within the runtime group set in p20080.		
Note:	The function blocks with a lower run sequence value are calculated before function blocks with a higher run sequence value.		
p20082	BI: NOT 1 input I / NOT 1 input I		
	Access level: 3	Calculated: -	Data type: U32 / Binary
	Can be changed: T	Scaling: -	Dyn. index: -
	Unit group: -	Unit selection: -	Func. diagram: 7216
	Min	Max	Factory setting
	-	-	0
Description:	Sets the signal source of input quantity I of instance NOT 1 of the inverter.		
r20083	BO: NOT 1 inverted output / NOT 1 inv output		
	Access level: 3	Calculated: -	Data type: Unsigned32
	Can be changed: -	Scaling: -	Dyn. index: -
	Unit group: -	Unit selection: -	Func. diagram: 7216
	Min	Max	Factory setting
	-	-	-
Description:	Display parameter for the inverted output of instance NOT 1 of the inverter.		

p20084	NOT 1 runtime group / NOT 1 RTG		
	Access level: 3	Calculated: -	Data type: Integer16
	Can be changed: T	Scaling: -	Dyn. index: -
	Unit group: -	Unit selection: -	Func. diagram: 7216
	Min	Max	Factory setting
	1	9999	9999
Description:	Setting parameter for the runtime group in which the instance NOT 1 of the inverter is to be called.		
Value:	1: Runtime group 1 2: Runtime group 2 3: Runtime group 3 4: Runtime group 4 5: Runtime group 5 6: Runtime group 6 9999: Do not calculate		
p20085	NOT 1 run sequence / NOT 1 RunSeq		
	Access level: 3	Calculated: -	Data type: Unsigned16
	Can be changed: T	Scaling: -	Dyn. index: -
	Unit group: -	Unit selection: -	Func. diagram: 7216
	Min	Max	Factory setting
	0	32000	170
Description:	Setting parameter for the run sequence of instance NOT 1 within the runtime group set in p20084.		
Note:	The function blocks with a lower run sequence value are calculated before function blocks with a higher run sequence value.		
p20086	BI: NOT 2 input I / NOT 2 input I		
	Access level: 3	Calculated: -	Data type: U32 / Binary
	Can be changed: T	Scaling: -	Dyn. index: -
	Unit group: -	Unit selection: -	Func. diagram: 7216
	Min	Max	Factory setting
	-	-	0
Description:	Sets the signal source of input quantity I of instance NOT 2 of the inverter.		
r20087	BO: NOT 2 inverted output / NOT 2 inv output		
	Access level: 3	Calculated: -	Data type: Unsigned32
	Can be changed: -	Scaling: -	Dyn. index: -
	Unit group: -	Unit selection: -	Func. diagram: 7216
	Min	Max	Factory setting
	-	-	-
Description:	Display parameter for the inverted output of instance NOT 2 of the inverter.		
p20088	NOT 2 runtime group / NOT 2 RTG		
	Access level: 3	Calculated: -	Data type: Integer16
	Can be changed: T	Scaling: -	Dyn. index: -
	Unit group: -	Unit selection: -	Func. diagram: 7216
	Min	Max	Factory setting
	1	9999	9999
Description:	Setting parameter for the runtime group in which the instance NOT 2 of the inverter is to be called.		

2 Parameters

2.2 List of parameters

Value:

1:	Runtime group 1
2:	Runtime group 2
3:	Runtime group 3
4:	Runtime group 4
5:	Runtime group 5
6:	Runtime group 6
9999:	Do not calculate

p20089	NOT 2 run sequence / NOT 2 RunSeq		
Access level: 3	Calculated: -	Data type: Unsigned16	
Can be changed: T	Scaling: -	Dyn. index: -	
Unit group: -	Unit selection: -	Func. diagram: 7216	
Min	Max	Factory setting	
0	32000	180	

Description: Setting parameter for the run sequence of instance NOT 2 within the runtime group set in p20088.
Note: The function blocks with a lower run sequence value are calculated before function blocks with a higher run sequence value.

p20090	BI: NOT 3 input I / NOT 3 input I		
Access level: 3	Calculated: -	Data type: U32 / Binary	
Can be changed: T	Scaling: -	Dyn. index: -	
Unit group: -	Unit selection: -	Func. diagram: 7216	
Min	Max	Factory setting	
-	-	0	

Description: Sets the signal source of input quantity I of instance NOT 3 of the inverter.

r20091	BO: NOT 3 inverted output / NOT 3 inv output		
Access level: 3	Calculated: -	Data type: Unsigned32	
Can be changed: -	Scaling: -	Dyn. index: -	
Unit group: -	Unit selection: -	Func. diagram: 7216	
Min	Max	Factory setting	
-	-	-	

Description: Display parameter for the inverted output of instance NOT 3 of the inverter.

p20092	NOT 3 runtime group / NOT 3 RTG		
Access level: 3	Calculated: -	Data type: Integer16	
Can be changed: T	Scaling: -	Dyn. index: -	
Unit group: -	Unit selection: -	Func. diagram: 7216	
Min	Max	Factory setting	
1	9999	9999	

Description: Setting parameter for the runtime group in which the instance NOT 3 of the inverter is to be called.
Value:

1:	Runtime group 1
2:	Runtime group 2
3:	Runtime group 3
4:	Runtime group 4
5:	Runtime group 5
6:	Runtime group 6
9999:	Do not calculate

p20093	NOT 3 run sequence / NOT 3 RunSeq		
	Access level: 3	Calculated: -	Data type: Unsigned16
	Can be changed: T	Scaling: -	Dyn. index: -
	Unit group: -	Unit selection: -	Func. diagram: 7216
	Min	Max	Factory setting
	0	32000	190
Description:	Setting parameter for the run sequence of instance NOT 3 within the runtime group set in p20092.		
Note:	The function blocks with a lower run sequence value are calculated before function blocks with a higher run sequence value.		
p20094[0...3]	CI: ADD 0 inputs / ADD 0 inputs		
	Access level: 3	Calculated: -	Data type: U32 / FloatingPoint32
	Can be changed: T	Scaling: PERCENT	Dyn. index: -
	Unit group: -	Unit selection: -	Func. diagram: 7220
	Min	Max	Factory setting
	-	-	0
Description:	Sets the signal source of input quantities X0, X1, X2, X3 of instance ADD 0 of the adder.		
Index:	[0] = Input X0 [1] = Input X1 [2] = Input X2 [3] = Input X3		
r20095	CO: ADD 0 output Y / ADD 0 output Y		
	Access level: 3	Calculated: -	Data type: FloatingPoint32
	Can be changed: -	Scaling: PERCENT	Dyn. index: -
	Unit group: -	Unit selection: -	Func. diagram: 7220
	Min	Max	Factory setting
	-	-	-
Description:	Display parameter for the output quantity $Y = X0 + X1 + X2 + X3$ of instance ADD 0 of the adder.		
p20096	ADD 0 runtime group / ADD 0 RTG		
	Access level: 3	Calculated: -	Data type: Integer16
	Can be changed: T	Scaling: -	Dyn. index: -
	Unit group: -	Unit selection: -	Func. diagram: 7220
	Min	Max	Factory setting
	5	9999	9999
Description:	Setting parameter for the runtime group in which the instance ADD 0 of the adder is to be called.		
Value:	5: Runtime group 5 6: Runtime group 6 9999: Do not calculate		
p20097	ADD 0 run sequence / ADD 0 RunSeq		
	Access level: 3	Calculated: -	Data type: Unsigned16
	Can be changed: T	Scaling: -	Dyn. index: -
	Unit group: -	Unit selection: -	Func. diagram: 7220
	Min	Max	Factory setting
	0	32000	210
Description:	Setting parameter for the run sequence of instance ADD 0 within the runtime group set in p20096.		
Note:	The function blocks with a lower run sequence value are calculated before function blocks with a higher run sequence value.		

p20098[0...3]	CI: ADD 1 inputs / ADD 1 inputs		
	Access level: 3	Calculated: -	Data type: U32 / FloatingPoint32
	Can be changed: T	Scaling: PERCENT	Dyn. index: -
	Unit group: -	Unit selection: -	Func. diagram: 7220
	Min	Max	Factory setting
	-	-	0
Description:	Sets the signal source of input quantities X0, X1, X2, X3 of instance ADD 1 of the adder.		
Index:	[0] = Input X0 [1] = Input X1 [2] = Input X2 [3] = Input X3		
r20099	CO: ADD 1 output Y / ADD 1 output Y		
	Access level: 3	Calculated: -	Data type: FloatingPoint32
	Can be changed: -	Scaling: PERCENT	Dyn. index: -
	Unit group: -	Unit selection: -	Func. diagram: 7220
	Min	Max	Factory setting
	-	-	-
Description:	Display parameter for the output quantity $Y = X0 + X1 + X2 + X3$ of instance ADD 1 of the adder.		
p20100	ADD 1 runtime group / ADD 1 RTG		
	Access level: 3	Calculated: -	Data type: Integer16
	Can be changed: T	Scaling: -	Dyn. index: -
	Unit group: -	Unit selection: -	Func. diagram: 7220
	Min	Max	Factory setting
	5	9999	9999
Description:	Setting parameter for the runtime group in which the instance ADD 1 of the adder is to be called.		
Value:	5: Runtime group 5 6: Runtime group 6 9999: Do not calculate		
p20101	ADD 1 run sequence / ADD 1 RunSeq		
	Access level: 3	Calculated: -	Data type: Unsigned16
	Can be changed: T	Scaling: -	Dyn. index: -
	Unit group: -	Unit selection: -	Func. diagram: 7220
	Min	Max	Factory setting
	0	32000	220
Description:	Setting parameter for the run sequence of instance ADD 1 within the runtime group set in p20100.		
Note:	The function blocks with a lower run sequence value are calculated before function blocks with a higher run sequence value.		
p20102[0...1]	CI: SUB 0 inputs / SUB 0 inputs		
	Access level: 3	Calculated: -	Data type: U32 / FloatingPoint32
	Can be changed: T	Scaling: PERCENT	Dyn. index: -
	Unit group: -	Unit selection: -	Func. diagram: 7220
	Min	Max	Factory setting
	-	-	0
Description:	Sets the signal source of minuend X1 and subtrahend X2 of instance SUB 0 of the subtractor.		
Index:	[0] = Minuend X1 [1] = Subtrahend X2		

r20103	CO: SUB 0 difference Y / SUB 0 difference Y		
	Access level: 3	Calculated: -	Data type: FloatingPoint32
	Can be changed: -	Scaling: PERCENT	Dyn. index: -
	Unit group: -	Unit selection: -	Func. diagram: 7220
	Min	Max	Factory setting
	-	-	-
Description:	Display parameter for the difference $Y = X1 - X2$ of instance SUB 0 of the subtractor.		
p20104	SUB 0 runtime group / SUB 0 RTG		
	Access level: 3	Calculated: -	Data type: Integer16
	Can be changed: T	Scaling: -	Dyn. index: -
	Unit group: -	Unit selection: -	Func. diagram: 7220
	Min	Max	Factory setting
	5	9999	9999
Description:	Setting parameter for the runtime group in which instance SUB 0 of the subtractor is to be called.		
Value:	5: Runtime group 5 6: Runtime group 6 9999: Do not calculate		
p20105	SUB 0 run sequence / SUB 0 RunSeq		
	Access level: 3	Calculated: -	Data type: Unsigned16
	Can be changed: T	Scaling: -	Dyn. index: -
	Unit group: -	Unit selection: -	Func. diagram: 7220
	Min	Max	Factory setting
	0	32000	240
Description:	Setting parameter for the run sequence of instance SUB 0 within the runtime group set in p20104.		
Note:	The function blocks with a lower run sequence value are calculated before function blocks with a higher run sequence value.		
p20106[0...1]	CI: SUB 1 inputs / SUB 1 inputs		
	Access level: 3	Calculated: -	Data type: U32 / FloatingPoint32
	Can be changed: T	Scaling: PERCENT	Dyn. index: -
	Unit group: -	Unit selection: -	Func. diagram: 7220
	Min	Max	Factory setting
	-	-	0
Description:	Sets the signal source of minuend X1 and subtrahend X2 of instance SUB 1 of the subtractor.		
Index:	[0] = Minuend X1 [1] = Subtrahend X2		
r20107	CO: SUB 1 difference Y / SUB 1 difference Y		
	Access level: 3	Calculated: -	Data type: FloatingPoint32
	Can be changed: -	Scaling: PERCENT	Dyn. index: -
	Unit group: -	Unit selection: -	Func. diagram: 7220
	Min	Max	Factory setting
	-	-	-
Description:	Display parameter for the difference $Y = X1 - X2$ of instance SUB 1 of the subtractor.		

p20108	SUB 1 runtime group / SUB 1 RTG		
	Access level: 3	Calculated: -	Data type: Integer16
	Can be changed: T	Scaling: -	Dyn. index: -
	Unit group: -	Unit selection: -	Func. diagram: 7220
	Min	Max	Factory setting
	5	9999	9999
Description:	Setting parameter for the runtime group in which instance SUB 1 of the subtractor is to be called.		
Value:	5: Runtime group 5 6: Runtime group 6 9999: Do not calculate		
p20109	SUB 1 run sequence / SUB 1 RunSeq		
	Access level: 3	Calculated: -	Data type: Unsigned16
	Can be changed: T	Scaling: -	Dyn. index: -
	Unit group: -	Unit selection: -	Func. diagram: 7220
	Min	Max	Factory setting
	0	32000	250
Description:	Setting parameter for the run sequence of instance SUB 1 within the runtime group set in p20108.		
Note:	The function blocks with a lower run sequence value are calculated before function blocks with a higher run sequence value.		
p20110[0...3]	CI: MUL 0 inputs / MUL 0 inputs		
	Access level: 3	Calculated: -	Data type: U32 / FloatingPoint32
	Can be changed: T	Scaling: PERCENT	Dyn. index: -
	Unit group: -	Unit selection: -	Func. diagram: 7222
	Min	Max	Factory setting
	-	-	0
Description:	Sets the signal source of the factors X0, X1, X2, X3 of instance MUL 0 of the multiplier.		
Index:	[0] = Factor X0 [1] = Factor X1 [2] = Factor X2 [3] = Factor X3		
r20111	CO: MUL 0 product Y / MUL 0 product Y		
	Access level: 3	Calculated: -	Data type: FloatingPoint32
	Can be changed: -	Scaling: PERCENT	Dyn. index: -
	Unit group: -	Unit selection: -	Func. diagram: 7222
	Min	Max	Factory setting
	-	-	-
Description:	Display parameter for the product $Y = X0 * X1 * X2 * X3$ of instance MUL 0 of the multiplier.		
p20112	MUL 0 runtime group / MUL 0 RTG		
	Access level: 3	Calculated: -	Data type: Integer16
	Can be changed: T	Scaling: -	Dyn. index: -
	Unit group: -	Unit selection: -	Func. diagram: 7222
	Min	Max	Factory setting
	5	9999	9999
Description:	Setting parameter for the runtime group in which instance MUL 0 of the multiplier is to be called.		
Value:	5: Runtime group 5 6: Runtime group 6 9999: Do not calculate		

p20113	MUL 0 run sequence / MUL 0 RunSeq		
	Access level: 3	Calculated: -	Data type: Unsigned16
	Can be changed: T	Scaling: -	Dyn. index: -
	Unit group: -	Unit selection: -	Func. diagram: 7222
	Min	Max	Factory setting
	0	32000	270
Description:	Setting parameter for the run sequence of instance MUL 0 within the runtime group set in p20112.		
Note:	The function blocks with a lower run sequence value are calculated before function blocks with a higher run sequence value.		
p20114[0...3]	CI: MUL 1 inputs / MUL 1 inputs		
	Access level: 3	Calculated: -	Data type: U32 / FloatingPoint32
	Can be changed: T	Scaling: PERCENT	Dyn. index: -
	Unit group: -	Unit selection: -	Func. diagram: 7222
	Min	Max	Factory setting
	-	-	0
Description:	Sets the signal source of the factors X0, X1, X2, X3 of instance MUL 1 of the multiplier.		
Index:	[0] = Factor X0 [1] = Factor X1 [2] = Factor X2 [3] = Factor X3		
r20115	CO: MUL 1 product Y / MUL 1 product Y		
	Access level: 3	Calculated: -	Data type: FloatingPoint32
	Can be changed: -	Scaling: PERCENT	Dyn. index: -
	Unit group: -	Unit selection: -	Func. diagram: 7222
	Min	Max	Factory setting
	-	-	-
Description:	Display parameter for the product $Y = X0 * X1 * X2 * X3$ of instance MUL 1 of the multiplier.		
p20116	MUL 1 runtime group / MUL 1 RTG		
	Access level: 3	Calculated: -	Data type: Integer16
	Can be changed: T	Scaling: -	Dyn. index: -
	Unit group: -	Unit selection: -	Func. diagram: 7222
	Min	Max	Factory setting
	5	9999	9999
Description:	Setting parameter for the runtime group in which instance MUL 1 of the multiplier is to be called.		
Value:	5: Runtime group 5 6: Runtime group 6 9999: Do not calculate		
p20117	MUL 1 run sequence / MUL 1 RunSeq		
	Access level: 3	Calculated: -	Data type: Unsigned16
	Can be changed: T	Scaling: -	Dyn. index: -
	Unit group: -	Unit selection: -	Func. diagram: 7222
	Min	Max	Factory setting
	0	32000	280
Description:	Setting parameter for the run sequence of instance MUL 1 within the runtime group set in p20116.		
Note:	The function blocks with a lower run sequence value are calculated before function blocks with a higher run sequence value.		

p20118[0...1]	CI: DIV 0 inputs / DIV 0 inputs		
	Access level: 3	Calculated: -	Data type: U32 / FloatingPoint32
	Can be changed: T	Scaling: PERCENT	Dyn. index: -
	Unit group: -	Unit selection: -	Func. diagram: 7222
	Min	Max	Factory setting
	-	-	0
Description:	Sets the signal source of dividend X1 and divisor X2 of instance DIV 0 of the divider.		
Index:	[0] = Dividend X0 [1] = Divisor X1		
r20119[0...2]	CO: DIV 0 quotient / DIV 0 quotient		
	Access level: 3	Calculated: -	Data type: FloatingPoint32
	Can be changed: -	Scaling: PERCENT	Dyn. index: -
	Unit group: -	Unit selection: -	Func. diagram: 7222
	Min	Max	Factory setting
	-	-	-
Description:	Display parameter for quotients $Y = X1 / X2$, integer number quotients YIN, and division remainder $MOD = (Y - YIN) \times X2$ of instance DIV 0 of the divider.		
Index:	[0] = Quotient Y [1] = Integer number quotient YIN [2] = Div remainder MOD		
r20120	BO: DIV 0 divisor is zero QF / DIV 0 divisor=0 QF		
	Access level: 3	Calculated: -	Data type: Unsigned32
	Can be changed: -	Scaling: -	Dyn. index: -
	Unit group: -	Unit selection: -	Func. diagram: 7222
	Min	Max	Factory setting
	-	-	-
Description:	Display parameter for the signal QF that the divisor X2 of instance DIV 0 of the divider is zero. $X2 = 0.0 \Rightarrow QF = 1$		
p20121	DIV 0 runtime group / DIV 0 RTG		
	Access level: 3	Calculated: -	Data type: Integer16
	Can be changed: T	Scaling: -	Dyn. index: -
	Unit group: -	Unit selection: -	Func. diagram: 7222
	Min	Max	Factory setting
	5	9999	9999
Description:	Setting parameter for the runtime group in which instance DIV 0 of the divider is to be called.		
Value:	5: Runtime group 5 6: Runtime group 6 9999: Do not calculate		
p20122	DIV 0 run sequence / DIV 0 RunSeq		
	Access level: 3	Calculated: -	Data type: Unsigned16
	Can be changed: T	Scaling: -	Dyn. index: -
	Unit group: -	Unit selection: -	Func. diagram: 7222
	Min	Max	Factory setting
	0	32000	300
Description:	Setting parameter for the run sequence of instance DIV 0 within the runtime group set in p20121.		
Note:	The function blocks with a lower run sequence value are calculated before function blocks with a higher run sequence value.		

p20123[0...1]	CI: DIV 1 inputs / DIV 1 inputs		
	Access level: 3	Calculated: -	Data type: U32 / FloatingPoint32
	Can be changed: T	Scaling: PERCENT	Dyn. index: -
	Unit group: -	Unit selection: -	Func. diagram: 7222
	Min	Max	Factory setting
	-	-	0
Description:	Sets the signal source of dividend X1 and divisor X2 of instance DIV 1 of the divider.		
Index:	[0] = Dividend X0 [1] = Divisor X1		
r20124[0...2]	CO: DIV 1 quotient / DIV 1 quotient		
	Access level: 3	Calculated: -	Data type: FloatingPoint32
	Can be changed: -	Scaling: PERCENT	Dyn. index: -
	Unit group: -	Unit selection: -	Func. diagram: 7222
	Min	Max	Factory setting
	-	-	-
Description:	Display parameter for quotients $Y = X1 / X2$, the integer number quotients YIN, and division remainder $MOD = (Y - YIN) \times X2$ of instance DIV 1 of the divider.		
Index:	[0] = Quotient Y [1] = Integer number quotient YIN [2] = Div remainder MOD		
r20125	BO: DIV 1 divisor is zero QF / DIV 1 divisor=0 QF		
	Access level: 3	Calculated: -	Data type: Unsigned32
	Can be changed: -	Scaling: -	Dyn. index: -
	Unit group: -	Unit selection: -	Func. diagram: 7222
	Min	Max	Factory setting
	-	-	-
Description:	Display parameter for the signal QF that the divisor X2 of instance DIV 1 of the divider is zero. $X2 = 0.0 \Rightarrow QF = 1$		
p20126	DIV 1 runtime group / DIV 1 RTG		
	Access level: 3	Calculated: -	Data type: Integer16
	Can be changed: T	Scaling: -	Dyn. index: -
	Unit group: -	Unit selection: -	Func. diagram: 7222
	Min	Max	Factory setting
	5	9999	9999
Description:	Setting parameter for the runtime group in which instance DIV 1 of the divider is to be called.		
Value:	5: Runtime group 5 6: Runtime group 6 9999: Do not calculate		
p20127	DIV 1 run sequence / DIV 1 RunSeq		
	Access level: 3	Calculated: -	Data type: Unsigned16
	Can be changed: T	Scaling: -	Dyn. index: -
	Unit group: -	Unit selection: -	Func. diagram: 7222
	Min	Max	Factory setting
	0	32000	310
Description:	Setting parameter for the run sequence of instance DIV 1 within the runtime group set in p20126.		
Note:	The function blocks with a lower run sequence value are calculated before function blocks with a higher run sequence value.		

2 Parameters

2.2 List of parameters

p20128	CI: AVA 0 input X / AVA 0 input X		
	Access level: 3	Calculated: -	Data type: U32 / FloatingPoint32
	Can be changed: T	Scaling: PERCENT	Dyn. index: -
	Unit group: -	Unit selection: -	Func. diagram: 7224
	Min	Max	Factory setting
	-	-	0
Description:	Sets the signal source of the input quantity X of instance AVA 0 of the absolute value generator with sign evaluation.		

r20129	CO: AVA 0 output Y / AVA 0 output Y		
	Access level: 3	Calculated: -	Data type: FloatingPoint32
	Can be changed: -	Scaling: PERCENT	Dyn. index: -
	Unit group: -	Unit selection: -	Func. diagram: 7224
	Min	Max	Factory setting
	-	-	-
Description:	Display parameter for output quantity Y of instance AVA 0 of the absolute value generator with sign evaluation.		

r20130	BO: AVA 0 input negative SN / AVA 0 input neg SN		
	Access level: 3	Calculated: -	Data type: Unsigned32
	Can be changed: -	Scaling: -	Dyn. index: -
	Unit group: -	Unit selection: -	Func. diagram: 7224
	Min	Max	Factory setting
	-	-	-
Description:	Display parameter for signal SN that the input quantity X of instance AVA 0 of the absolute value generator with sign evaluation is negative. $X < 0.0 \Rightarrow SN = 1$		

p20131	AVA 0 runtime group / AVA 0 RTG		
	Access level: 3	Calculated: -	Data type: Integer16
	Can be changed: T	Scaling: -	Dyn. index: -
	Unit group: -	Unit selection: -	Func. diagram: 7224
	Min	Max	Factory setting
	5	9999	9999
Description:	Setting parameter for the runtime group in which instance AVA 0 of the absolute value generator with sign evaluation is to be called.		
Value:	5: Runtime group 5 6: Runtime group 6 9999: Do not calculate		

p20132	AVA 0 run sequence / AVA 0 RunSeq		
	Access level: 3	Calculated: -	Data type: Unsigned16
	Can be changed: T	Scaling: -	Dyn. index: -
	Unit group: -	Unit selection: -	Func. diagram: 7224
	Min	Max	Factory setting
	0	32000	340
Description:	Setting parameter for the run sequence of instance AVA 0 within the runtime group set in p20131.		
Note:	The function blocks with a lower run sequence value are calculated before function blocks with a higher run sequence value.		

p20133	CI: AVA 1 input X / AVA 1 input X		
	Access level: 3	Calculated: -	Data type: U32 / FloatingPoint32
	Can be changed: T	Scaling: PERCENT	Dyn. index: -
	Unit group: -	Unit selection: -	Func. diagram: 7224
	Min	Max	Factory setting
	-	-	0
Description:	Sets the signal source of the input quantity X of instance AVA 1 of the absolute value generator with sign evaluation.		
r20134	CO: AVA 1 output Y / AVA 1 output Y		
	Access level: 3	Calculated: -	Data type: FloatingPoint32
	Can be changed: -	Scaling: PERCENT	Dyn. index: -
	Unit group: -	Unit selection: -	Func. diagram: 7224
	Min	Max	Factory setting
	-	-	-
Description:	Display parameter for output quantity Y of instance AVA 1 of the absolute value generator with sign evaluation.		
r20135	BO: AVA 1 input negative SN / AVA 1 input neg SN		
	Access level: 3	Calculated: -	Data type: Unsigned32
	Can be changed: -	Scaling: -	Dyn. index: -
	Unit group: -	Unit selection: -	Func. diagram: 7224
	Min	Max	Factory setting
	-	-	-
Description:	Display parameter for signal SN that the input quantity X of instance AVA 1 of the absolute value generator with sign evaluation is negative. X < 0.0 => SN = 1		
p20136	AVA 1 runtime group / AVA 1 RTG		
	Access level: 3	Calculated: -	Data type: Integer16
	Can be changed: T	Scaling: -	Dyn. index: -
	Unit group: -	Unit selection: -	Func. diagram: 7224
	Min	Max	Factory setting
	5	9999	9999
Description:	Setting parameter for the runtime group in which instance AVA 1 of the absolute value generator with sign evaluation is to be called.		
Value:	5: Runtime group 5 6: Runtime group 6 9999: Do not calculate		
p20137	AVA 1 run sequence / AVA 1 RunSeq		
	Access level: 3	Calculated: -	Data type: Unsigned16
	Can be changed: T	Scaling: -	Dyn. index: -
	Unit group: -	Unit selection: -	Func. diagram: 7224
	Min	Max	Factory setting
	0	32000	350
Description:	Setting parameter for the run sequence of instance AVA 1 within the runtime group set in p20136.		
Note:	The function blocks with a lower run sequence value are calculated before function blocks with a higher run sequence value.		

p20138	BI: MFP 0 input pulse I / MFP 0 inp_pulse I		
	Access level: 3	Calculated: -	Data type: U32 / Binary
	Can be changed: T	Scaling: -	Dyn. index: -
	Unit group: -	Unit selection: -	Func. diagram: 7230
	Min	Max	Factory setting
	-	-	0
Description:	Sets the signal source for the input pulse I of instance MFP 0 of the pulse generator.		
p20139	MFP 0 pulse duration in ms / MFP 0 pulse_dur ms		
	Access level: 3	Calculated: -	Data type: FloatingPoint32
	Can be changed: T	Scaling: -	Dyn. index: -
	Unit group: -	Unit selection: -	Func. diagram: 7230
	Min	Max	Factory setting
	0.00	5400000.00	0.00
Description:	Setting parameter for pulse duration T in milliseconds of instance MFP 0 of the pulse generator.		
r20140	BO: MFP 0 output Q / MFP 0 output Q		
	Access level: 3	Calculated: -	Data type: Unsigned32
	Can be changed: -	Scaling: -	Dyn. index: -
	Unit group: -	Unit selection: -	Func. diagram: 7230
	Min	Max	Factory setting
	-	-	-
Description:	Display parameter for output pulse Q of instance MFP 0 of the pulse generator.		
p20141	MFP 0 runtime group / MFP 0 RTG		
	Access level: 3	Calculated: -	Data type: Integer16
	Can be changed: T	Scaling: -	Dyn. index: -
	Unit group: -	Unit selection: -	Func. diagram: 7230
	Min	Max	Factory setting
	5	9999	9999
Description:	Setting parameter for the runtime group in which the instance MFP 0 of the pulse generator is to be called.		
Value:	5: Runtime group 5 6: Runtime group 6 9999: Do not calculate		
p20142	MFP 0 run sequence / MFP 0 RunSeq		
	Access level: 3	Calculated: -	Data type: Unsigned16
	Can be changed: T	Scaling: -	Dyn. index: -
	Unit group: -	Unit selection: -	Func. diagram: 7230
	Min	Max	Factory setting
	0	32000	370
Description:	Setting parameter for the run sequence of instance MFP 0 within the runtime group set in p20141.		
Note:	The function blocks with a lower run sequence value are calculated before function blocks with a higher run sequence value.		
p20143	BI: MFP 1 input pulse I / MFP 1 inp_pulse I		
	Access level: 3	Calculated: -	Data type: U32 / Binary
	Can be changed: T	Scaling: -	Dyn. index: -
	Unit group: -	Unit selection: -	Func. diagram: 7230
	Min	Max	Factory setting
	-	-	0
Description:	Sets the signal source for the input pulse I of instance MFP 1 of the pulse generator.		

p20144	MFP 1 pulse duration in ms / MFP 1 pulse_dur ms		
	Access level: 3	Calculated: -	Data type: FloatingPoint32
	Can be changed: T	Scaling: -	Dyn. index: -
	Unit group: -	Unit selection: -	Func. diagram: 7230
	Min	Max	Factory setting
	0.00	5400000.00	0.00
Description:	Setting parameter for pulse duration T in milliseconds of instance MFP 1 of the pulse generator.		
r20145	BO: MFP 1 output Q / MFP 1 output Q		
	Access level: 3	Calculated: -	Data type: Unsigned32
	Can be changed: -	Scaling: -	Dyn. index: -
	Unit group: -	Unit selection: -	Func. diagram: 7230
	Min	Max	Factory setting
	-	-	-
Description:	Display parameter for output pulse Q of instance MFP 1 of the pulse generator.		
p20146	MFP 1 runtime group / MFP 1 RTG		
	Access level: 3	Calculated: -	Data type: Integer16
	Can be changed: T	Scaling: -	Dyn. index: -
	Unit group: -	Unit selection: -	Func. diagram: 7230
	Min	Max	Factory setting
	5	9999	9999
Description:	Setting parameter for the runtime group in which the instance MFP 1 of the pulse generator is to be called.		
Value:	5: Runtime group 5 6: Runtime group 6 9999: Do not calculate		
p20147	MFP 1 run sequence / MFP 1 RunSeq		
	Access level: 3	Calculated: -	Data type: Unsigned16
	Can be changed: T	Scaling: -	Dyn. index: -
	Unit group: -	Unit selection: -	Func. diagram: 7230
	Min	Max	Factory setting
	0	32000	380
Description:	Setting parameter for the run sequence of instance MFP 1 within the runtime group set in p20146.		
Note:	The function blocks with a lower run sequence value are calculated before function blocks with a higher run sequence value.		
p20148	BI: PCL 0 input pulse I / PCL 0 inp_pulse I		
	Access level: 3	Calculated: -	Data type: U32 / Binary
	Can be changed: T	Scaling: -	Dyn. index: -
	Unit group: -	Unit selection: -	Func. diagram: 7230
	Min	Max	Factory setting
	-	-	0
Description:	Sets the signal source for the input pulse I of instance PCL 0 of the pulse shortener.		
p20149	PCL 0 pulse duration in ms / PCL 0 pulse_dur ms		
	Access level: 3	Calculated: -	Data type: FloatingPoint32
	Can be changed: T	Scaling: -	Dyn. index: -
	Unit group: -	Unit selection: -	Func. diagram: 7230
	Min	Max	Factory setting
	0.00	5400000.00	0.00
Description:	Setting parameter for pulse duration T in milliseconds of instance PCL 0 of the pulse shortener.		

2 Parameters

2.2 List of parameters

r20150	BO: PCL 0 output Q / PCL 0 output Q		
	Access level: 3	Calculated: -	Data type: Unsigned32
	Can be changed: -	Scaling: -	Dyn. index: -
	Unit group: -	Unit selection: -	Func. diagram: 7230
	Min	Max	Factory setting
	-	-	-
Description:	Display parameter for output pulse Q of instance PCL 0 of the pulse shortener.		
p20151	PCL 0 runtime group / PCL 0 RTG		
	Access level: 3	Calculated: -	Data type: Integer16
	Can be changed: T	Scaling: -	Dyn. index: -
	Unit group: -	Unit selection: -	Func. diagram: 7230
	Min	Max	Factory setting
	5	9999	9999
Description:	Setting parameter for the runtime group in which the instance PCL 0 of the pulse shortener is to be called.		
Value:	5: Runtime group 5 6: Runtime group 6 9999: Do not calculate		
p20152	PCL 0 run sequence / PCL 0 RunSeq		
	Access level: 3	Calculated: -	Data type: Unsigned16
	Can be changed: T	Scaling: -	Dyn. index: -
	Unit group: -	Unit selection: -	Func. diagram: 7230
	Min	Max	Factory setting
	0	32000	400
Description:	Setting parameter for the run sequence of instance PCL 0 within the runtime group set in p20151.		
Note:	The function blocks with a lower run sequence value are calculated before function blocks with a higher run sequence value.		
p20153	BI: PCL 1 input pulse I / PCL 1 inp_pulse I		
	Access level: 3	Calculated: -	Data type: U32 / Binary
	Can be changed: T	Scaling: -	Dyn. index: -
	Unit group: -	Unit selection: -	Func. diagram: 7230
	Min	Max	Factory setting
	-	-	0
Description:	Sets the signal source for the input pulse I of instance PCL 1 of the pulse shortener.		
p20154	PCL 1 pulse duration in ms / PCL 1 pulse_dur ms		
	Access level: 3	Calculated: -	Data type: FloatingPoint32
	Can be changed: T	Scaling: -	Dyn. index: -
	Unit group: -	Unit selection: -	Func. diagram: 7230
	Min	Max	Factory setting
	0.00	5400000.00	0.00
Description:	Setting parameter for pulse duration T in milliseconds of instance PCL 1 of the pulse shortener.		
r20155	BO: PCL 1 output Q / PCL 1 output Q		
	Access level: 3	Calculated: -	Data type: Unsigned32
	Can be changed: -	Scaling: -	Dyn. index: -
	Unit group: -	Unit selection: -	Func. diagram: 7230
	Min	Max	Factory setting
	-	-	-
Description:	Display parameter for output pulse Q of instance PCL 1 of the pulse shortener.		

p20156	PCL 1 runtime group / PCL 1 RTG		
	Access level: 3	Calculated: -	Data type: Integer16
	Can be changed: T	Scaling: -	Dyn. index: -
	Unit group: -	Unit selection: -	Func. diagram: 7230
	Min	Max	Factory setting
	5	9999	9999
Description:	Setting parameter for the runtime group in which the instance PCL 1 of the pulse shortener is to be called.		
Value:	5: Runtime group 5 6: Runtime group 6 9999: Do not calculate		
p20157	PCL 1 run sequence / PCL 1 RunSeq		
	Access level: 3	Calculated: -	Data type: Unsigned16
	Can be changed: T	Scaling: -	Dyn. index: -
	Unit group: -	Unit selection: -	Func. diagram: 7230
	Min	Max	Factory setting
	0	32000	410
Description:	Setting parameter for the run sequence of instance PCL 1 within the runtime group set in p20156.		
Note:	The function blocks with a lower run sequence value are calculated before function blocks with a higher run sequence value.		
p20158	BI: PDE 0 input pulse I / PDE 0 inp_pulse I		
	Access level: 3	Calculated: -	Data type: U32 / Binary
	Can be changed: T	Scaling: -	Dyn. index: -
	Unit group: -	Unit selection: -	Func. diagram: 7232
	Min	Max	Factory setting
	-	-	0
Description:	Sets the signal source for the input pulse I of instance PDE 0 of the closing delay device.		
p20159	PDE 0 pulse delay time in ms / PDE 0 t_del ms		
	Access level: 3	Calculated: -	Data type: FloatingPoint32
	Can be changed: T	Scaling: -	Dyn. index: -
	Unit group: -	Unit selection: -	Func. diagram: 7232
	Min	Max	Factory setting
	0.00	5400000.00	0.00
Description:	Setting parameter for pulse delay time T in milliseconds of instance PDE 0 of the closing delay device.		
r20160	BO: PDE 0 output Q / PDE 0 output Q		
	Access level: 3	Calculated: -	Data type: Unsigned32
	Can be changed: -	Scaling: -	Dyn. index: -
	Unit group: -	Unit selection: -	Func. diagram: 7232
	Min	Max	Factory setting
	-	-	-
Description:	Display parameter for output pulse Q of instance PDE 0 of the closing delay device.		
p20161	PDE 0 runtime group / PDE 0 RTG		
	Access level: 3	Calculated: -	Data type: Integer16
	Can be changed: T	Scaling: -	Dyn. index: -
	Unit group: -	Unit selection: -	Func. diagram: 7232
	Min	Max	Factory setting
	5	9999	9999
Description:	Setting parameter for the runtime group in which instance PDE 0 of the closing delay device is to be called.		

2 Parameters

2.2 List of parameters

Value: 5: Runtime group 5
6: Runtime group 6
9999: Do not calculate

p20162	PDE 0 run sequence / PDE 0 RunSeq		
	Access level: 3	Calculated: -	Data type: Unsigned16
	Can be changed: T	Scaling: -	Dyn. index: -
	Unit group: -	Unit selection: -	Func. diagram: 7232
	Min	Max	Factory setting
	0	32000	430
Description:	Setting parameter for the run sequence of instance PDE 0 within the runtime group set in p20161.		
Note:	The function blocks with a lower run sequence value are calculated before function blocks with a higher run sequence value.		

p20163	BI: PDE 1 input pulse I / PDE 1 inp_pulse I		
	Access level: 3	Calculated: -	Data type: U32 / Binary
	Can be changed: T	Scaling: -	Dyn. index: -
	Unit group: -	Unit selection: -	Func. diagram: 7232
	Min	Max	Factory setting
	-	-	0
Description:	Sets the signal source for the input pulse I of instance PDE 1 of the closing delay device.		

p20164	PDE 1 pulse delay time in ms / PDE 1 t_del ms		
	Access level: 3	Calculated: -	Data type: FloatingPoint32
	Can be changed: T	Scaling: -	Dyn. index: -
	Unit group: -	Unit selection: -	Func. diagram: 7232
	Min	Max	Factory setting
	0.00	5400000.00	0.00
Description:	Setting parameter for pulse delay time T in milliseconds of instance PDE 1 of the closing delay device.		

r20165	BO: PDE 1 output Q / PDE 1 output Q		
	Access level: 3	Calculated: -	Data type: Unsigned32
	Can be changed: -	Scaling: -	Dyn. index: -
	Unit group: -	Unit selection: -	Func. diagram: 7232
	Min	Max	Factory setting
	-	-	-
Description:	Display parameter for output pulse Q of instance PDE 1 of the closing delay device.		

p20166	PDE 1 runtime group / PDE 1 RTG		
	Access level: 3	Calculated: -	Data type: Integer16
	Can be changed: T	Scaling: -	Dyn. index: -
	Unit group: -	Unit selection: -	Func. diagram: 7232
	Min	Max	Factory setting
	5	9999	9999
Description:	Setting parameter for the runtime group in which instance PDE 1 of the closing delay device is to be called.		
Value:	5: Runtime group 5 6: Runtime group 6 9999: Do not calculate		

p20167	PDE 1 run sequence / PDE 1 RunSeq		
	Access level: 3	Calculated: -	Data type: Unsigned16
	Can be changed: T	Scaling: -	Dyn. index: -
	Unit group: -	Unit selection: -	Func. diagram: 7232
	Min	Max	Factory setting
	0	32000	440
Description:	Setting parameter for the run sequence of instance PDE 1 within the runtime group set in p20166.		
Note:	The function blocks with a lower run sequence value are calculated before function blocks with a higher run sequence value.		
p20168	BI: PDF 0 input pulse I / PDF 0 inp_pulse I		
	Access level: 3	Calculated: -	Data type: U32 / Binary
	Can be changed: T	Scaling: -	Dyn. index: -
	Unit group: -	Unit selection: -	Func. diagram: 7233
	Min	Max	Factory setting
	-	-	0
Description:	Sets the signal source for the input pulse I of instance PDF 0 of the breaking delay device.		
p20169	PDF 0 pulse extension time in ms / PDF 0 t_ext ms		
	Access level: 3	Calculated: -	Data type: FloatingPoint32
	Can be changed: T	Scaling: -	Dyn. index: -
	Unit group: -	Unit selection: -	Func. diagram: 7233
	Min	Max	Factory setting
	0.00	5400000.00	0.00
Description:	Setting parameter for pulse extension time T in milliseconds of instance PDF 0 of the breaking delay device.		
r20170	BO: PDF 0 output Q / PDF 0 output Q		
	Access level: 3	Calculated: -	Data type: Unsigned32
	Can be changed: -	Scaling: -	Dyn. index: -
	Unit group: -	Unit selection: -	Func. diagram: 7233
	Min	Max	Factory setting
	-	-	-
Description:	Display parameter for output pulse Q of instance PDF 0 of the breaking delay device.		
p20171	PDF 0 runtime group / PDF 0 RTG		
	Access level: 3	Calculated: -	Data type: Integer16
	Can be changed: T	Scaling: -	Dyn. index: -
	Unit group: -	Unit selection: -	Func. diagram: 7233
	Min	Max	Factory setting
	5	9999	9999
Description:	Setting parameter for the runtime group in which the instance PDF 0 of the breaking delay device is to be called.		
Value:	5: Runtime group 5 6: Runtime group 6 9999: Do not calculate		
p20172	PDF 0 run sequence / PDF 0 RunSeq		
	Access level: 3	Calculated: -	Data type: Unsigned16
	Can be changed: T	Scaling: -	Dyn. index: -
	Unit group: -	Unit selection: -	Func. diagram: 7233
	Min	Max	Factory setting
	0	32000	460
Description:	Setting parameter for the run sequence of instance PDF 0 within the runtime group set in p20171.		

2 Parameters

2.2 List of parameters

Note: The function blocks with a lower run sequence value are calculated before function blocks with a higher run sequence value.

p20173	BI: PDF 1 input pulse I / PDF 1 inp_pulse I		
	Access level: 3	Calculated: -	Data type: U32 / Binary
	Can be changed: T	Scaling: -	Dyn. index: -
	Unit group: -	Unit selection: -	Func. diagram: 7233
	Min	Max	Factory setting
	-	-	0

Description: Sets the signal source for the input pulse I of instance PDF 1 of the breaking delay device.

p20174	PDF 1 pulse extension time in ms / PDF 1 t_ext ms		
	Access level: 3	Calculated: -	Data type: FloatingPoint32
	Can be changed: T	Scaling: -	Dyn. index: -
	Unit group: -	Unit selection: -	Func. diagram: 7233
	Min	Max	Factory setting
	0.00	5400000.00	0.00

Description: Setting parameter for pulse extension time T in milliseconds of instance PDF 1 of the breaking delay device.

r20175	BO: PDF 1 output Q / PDF 1 output Q		
	Access level: 3	Calculated: -	Data type: Unsigned32
	Can be changed: -	Scaling: -	Dyn. index: -
	Unit group: -	Unit selection: -	Func. diagram: 7233
	Min	Max	Factory setting
	-	-	-

Description: Display parameter for output pulse Q of instance PDF 1 of the breaking delay device.

p20176	PDF 1 runtime group / PDF 1 RTG		
	Access level: 3	Calculated: -	Data type: Integer16
	Can be changed: T	Scaling: -	Dyn. index: -
	Unit group: -	Unit selection: -	Func. diagram: 7233
	Min	Max	Factory setting
	5	9999	9999

Description: Setting parameter for the runtime group in which the instance PDF 1 of the breaking delay device is to be called.

Value:
5: Runtime group 5
6: Runtime group 6
9999: Do not calculate

p20177	PDF 1 run sequence / PDF 1 RunSeq		
	Access level: 3	Calculated: -	Data type: Unsigned16
	Can be changed: T	Scaling: -	Dyn. index: -
	Unit group: -	Unit selection: -	Func. diagram: 7233
	Min	Max	Factory setting
	0	32000	470

Description: Setting parameter for the run sequence of instance PDF 1 within the runtime group set in p20176.

Note: The function blocks with a lower run sequence value are calculated before function blocks with a higher run sequence value.

p20178[0...1]	BI: PST 0 inputs / PST 0 inputs		
	Access level: 3	Calculated: -	Data type: U32 / Binary
	Can be changed: T	Scaling: -	Dyn. index: -
	Unit group: -	Unit selection: -	Func. diagram: 7234
	Min	Max	Factory setting
	-	-	0
Description:	Sets the signal source for input pulse I and the reset input R of instance PST 0 of the pulse extension element.		
Index:	[0] = Input pulse I [1] = Reset input R		
p20179	PST 0 pulse duration in ms / PST 0 pulse_dur ms		
	Access level: 3	Calculated: -	Data type: FloatingPoint32
	Can be changed: T	Scaling: -	Dyn. index: -
	Unit group: -	Unit selection: -	Func. diagram: 7234
	Min	Max	Factory setting
	0.00	5400000.00	0.00
Description:	Setting parameter for pulse duration T in milliseconds of instance PST 0 of the pulse extension element.		
r20180	BO: PST 0 output Q / PST 0 output Q		
	Access level: 3	Calculated: -	Data type: Unsigned32
	Can be changed: -	Scaling: -	Dyn. index: -
	Unit group: -	Unit selection: -	Func. diagram: 7234
	Min	Max	Factory setting
	-	-	-
Description:	Display parameter for output pulse Q of instance PST 0 of the pulse extension element.		
p20181	PST 0 runtime group / PST 0 RTG		
	Access level: 3	Calculated: -	Data type: Integer16
	Can be changed: T	Scaling: -	Dyn. index: -
	Unit group: -	Unit selection: -	Func. diagram: 7234
	Min	Max	Factory setting
	5	9999	9999
Description:	Setting parameter for the runtime group in which the instance PST 0 of the pulse extension element is to be called.		
Value:	5: Runtime group 5 6: Runtime group 6 9999: Do not calculate		
p20182	PST 0 run sequence / PST 0 RunSeq		
	Access level: 3	Calculated: -	Data type: Unsigned16
	Can be changed: T	Scaling: -	Dyn. index: -
	Unit group: -	Unit selection: -	Func. diagram: 7234
	Min	Max	Factory setting
	0	7999	490
Description:	Setting parameter for the run sequence of instance PST 0 within the runtime group set in p20181.		
Note:	The function blocks with a lower run sequence value are calculated before function blocks with a higher run sequence value.		

p20183[0...1]	BI: PST 1 inputs / PST 1 inputs		
	Access level: 3	Calculated: -	Data type: U32 / Binary
	Can be changed: T	Scaling: -	Dyn. index: -
	Unit group: -	Unit selection: -	Func. diagram: 7234
	Min	Max	Factory setting
	-	-	0
Description:	Sets the signal source for input pulse I and the reset input R of instance PST 1 of the pulse extension element.		
Index:	[0] = Input pulse I [1] = Reset input R		
p20184	PST 1 pulse duration in ms / PST 1 pulse_dur ms		
	Access level: 3	Calculated: -	Data type: FloatingPoint32
	Can be changed: T	Scaling: -	Dyn. index: -
	Unit group: -	Unit selection: -	Func. diagram: 7234
	Min	Max	Factory setting
	0.00	5400000.00	0.00
Description:	Setting parameter for pulse duration T in milliseconds of instance PST 1 of the pulse extension element.		
r20185	BO: PST 1 output Q / PST 1 output Q		
	Access level: 3	Calculated: -	Data type: Unsigned32
	Can be changed: -	Scaling: -	Dyn. index: -
	Unit group: -	Unit selection: -	Func. diagram: 7234
	Min	Max	Factory setting
	-	-	-
Description:	Display parameter for output pulse Q of instance PST 1 of the pulse extension element.		
p20186	PST 1 runtime group / PST 1 RTG		
	Access level: 3	Calculated: -	Data type: Integer16
	Can be changed: T	Scaling: -	Dyn. index: -
	Unit group: -	Unit selection: -	Func. diagram: 7234
	Min	Max	Factory setting
	5	9999	9999
Description:	Setting parameter for the runtime group in which the instance PST 1 of the pulse extension element is to be called.		
Value:	5: Runtime group 5 6: Runtime group 6 9999: Do not calculate		
p20187	PST 1 run sequence / PST 1 RunSeq		
	Access level: 3	Calculated: -	Data type: Unsigned16
	Can be changed: T	Scaling: -	Dyn. index: -
	Unit group: -	Unit selection: -	Func. diagram: 7234
	Min	Max	Factory setting
	0	7999	500
Description:	Setting parameter for the run sequence of instance PST 1 within the runtime group set in p20186.		
Note:	The function blocks with a lower run sequence value are calculated before function blocks with a higher run sequence value.		

p20188[0...1]	BI: RSR 0 inputs / RSR 0 inputs		
	Access level: 3	Calculated: -	Data type: U32 / Binary
	Can be changed: T	Scaling: -	Dyn. index: -
	Unit group: -	Unit selection: -	Func. diagram: 7240
	Min	Max	Factory setting
	-	-	0
Description:	Sets the signal source for set input S and reset input R of instance RSR 0 of the RS flipflop.		
Index:	[0] = Set S [1] = Reset R		
r20189	BO: RSR 0 output Q / RSR 0 output Q		
	Access level: 3	Calculated: -	Data type: Unsigned32
	Can be changed: -	Scaling: -	Dyn. index: -
	Unit group: -	Unit selection: -	Func. diagram: 7240
	Min	Max	Factory setting
	-	-	-
Description:	Display parameter for output Q of instance RSR 0 of the RS flipflop		
r20190	BO: RSR 0 inverted output QN / RSR 0 inv outp QN		
	Access level: 3	Calculated: -	Data type: Unsigned32
	Can be changed: -	Scaling: -	Dyn. index: -
	Unit group: -	Unit selection: -	Func. diagram: 7240
	Min	Max	Factory setting
	-	-	-
Description:	Display parameter for inverted output QN of instance RSR 0 of the RS flipflop.		
p20191	RSR 0 runtime group / RSR 0 RTG		
	Access level: 3	Calculated: -	Data type: Integer16
	Can be changed: T	Scaling: -	Dyn. index: -
	Unit group: -	Unit selection: -	Func. diagram: 7240
	Min	Max	Factory setting
	1	9999	9999
Description:	Setting parameter for the runtime group in which instance RSR 0 of the RS flipflop is to be called.		
Value:	1: Runtime group 1 2: Runtime group 2 3: Runtime group 3 4: Runtime group 4 5: Runtime group 5 6: Runtime group 6 9999: Do not calculate		
p20192	RSR 0 run sequence / RSR 0 RunSeq		
	Access level: 3	Calculated: -	Data type: Unsigned16
	Can be changed: T	Scaling: -	Dyn. index: -
	Unit group: -	Unit selection: -	Func. diagram: 7240
	Min	Max	Factory setting
	0	7999	520
Description:	Setting parameter for the run sequence of instance RSR 0 within the runtime group set in p20191.		
Note:	The function blocks with a lower run sequence value are calculated before function blocks with a higher run sequence value.		

2 Parameters

2.2 List of parameters

p20193[0...1]	BI: RSR 1 inputs / RSR 1 inputs		
	Access level: 3	Calculated: -	Data type: U32 / Binary
	Can be changed: T	Scaling: -	Dyn. index: -
	Unit group: -	Unit selection: -	Func. diagram: 7240
	Min	Max	Factory setting
	-	-	0
Description:	Sets the signal source for set input S and reset input R of instance RSR 1 of the RS flipflop.		
Index:	[0] = Set S [1] = Reset R		
r20194	BO: RSR 1 output Q / RSR 1 output Q		
	Access level: 3	Calculated: -	Data type: Unsigned32
	Can be changed: -	Scaling: -	Dyn. index: -
	Unit group: -	Unit selection: -	Func. diagram: 7240
	Min	Max	Factory setting
	-	-	-
Description:	Display parameter for output Q of instance RSR 1 of the RS flipflop		
r20195	BO: RSR 1 inverted output QN / RSR 1 inv outp QN		
	Access level: 3	Calculated: -	Data type: Unsigned32
	Can be changed: -	Scaling: -	Dyn. index: -
	Unit group: -	Unit selection: -	Func. diagram: 7240
	Min	Max	Factory setting
	-	-	-
Description:	Display parameter for inverted output QN of instance RSR 1 of the RS flipflop.		
p20196	RSR 1 runtime group / RSR 1 RTG		
	Access level: 3	Calculated: -	Data type: Integer16
	Can be changed: T	Scaling: -	Dyn. index: -
	Unit group: -	Unit selection: -	Func. diagram: 7240
	Min	Max	Factory setting
	1	9999	9999
Description:	Setting parameter for the runtime group in which instance RSR 1 of the RS flipflop is to be called.		
Value:	1: Runtime group 1 2: Runtime group 2 3: Runtime group 3 4: Runtime group 4 5: Runtime group 5 6: Runtime group 6 9999: Do not calculate		
p20197	RSR 1 run sequence / RSR 1 RunSeq		
	Access level: 3	Calculated: -	Data type: Unsigned16
	Can be changed: T	Scaling: -	Dyn. index: -
	Unit group: -	Unit selection: -	Func. diagram: 7240
	Min	Max	Factory setting
	0	7999	530
Description:	Setting parameter for the run sequence of instance RSR 1 within the runtime group set in p20196.		
Note:	The function blocks with a lower run sequence value are calculated before function blocks with a higher run sequence value.		

p20198[0...3]	BI: DFR 0 inputs / DFR 0 inputs		
	Access level: 3	Calculated: -	Data type: U32 / Binary
	Can be changed: T	Scaling: -	Dyn. index: -
	Unit group: -	Unit selection: -	Func. diagram: 7240
	Min	Max	Factory setting
	-	-	0
Description:	Sets the signal source for trigger input I, D input D, set input S, and reset input R of instance DFR 0 of the D flipflop.		
Index:	[0] = Trigger input I [1] = D input D [2] = Set S [3] = Reset R		
r20199	BO: DFR 0 output Q / DFR 0 output Q		
	Access level: 3	Calculated: -	Data type: Unsigned32
	Can be changed: -	Scaling: -	Dyn. index: -
	Unit group: -	Unit selection: -	Func. diagram: 7240
	Min	Max	Factory setting
	-	-	-
Description:	Display parameter for output Q of instance DFR 0 of the D flipflop.		
r20200	BO: DFR 0 inverted output QN / DFR 0 inv outp QN		
	Access level: 3	Calculated: -	Data type: Unsigned32
	Can be changed: -	Scaling: -	Dyn. index: -
	Unit group: -	Unit selection: -	Func. diagram: 7240
	Min	Max	Factory setting
	-	-	-
Description:	Display parameter for the inverted output QN of instance DFR 0 of the D flipflop.		
p20201	DFR 0 runtime group / DFR 0 RTG		
	Access level: 3	Calculated: -	Data type: Integer16
	Can be changed: T	Scaling: -	Dyn. index: -
	Unit group: -	Unit selection: -	Func. diagram: 7240
	Min	Max	Factory setting
	1	9999	9999
Description:	Setting parameter for the runtime group in which instance DFR 0 of the D flipflop is to be called.		
Value:	1: Runtime group 1 2: Runtime group 2 3: Runtime group 3 4: Runtime group 4 5: Runtime group 5 6: Runtime group 6 9999: Do not calculate		
p20202	DFR 0 run sequence / DFR 0 RunSeq		
	Access level: 3	Calculated: -	Data type: Unsigned16
	Can be changed: T	Scaling: -	Dyn. index: -
	Unit group: -	Unit selection: -	Func. diagram: 7240
	Min	Max	Factory setting
	0	32000	550
Description:	Setting parameter for the run sequence of instance DFR 0 within the runtime group set in p20201.		
Note:	The function blocks with a lower run sequence value are calculated before function blocks with a higher run sequence value.		

2 Parameters

2.2 List of parameters

p20203[0...3]	BI: DFR 1 inputs / DFR 1 inputs		
	Access level: 3	Calculated: -	Data type: U32 / Binary
	Can be changed: T	Scaling: -	Dyn. index: -
	Unit group: -	Unit selection: -	Func. diagram: 7240
	Min	Max	Factory setting
	-	-	0
Description:	Sets the signal source for trigger input I, D input D, set input S, and reset input R of instance DFR 1 of the D flipflop.		
Index:	[0] = Trigger input I [1] = D input D [2] = Set S [3] = Reset R		
r20204	BO: DFR 1 output Q / DFR 1 output Q		
	Access level: 3	Calculated: -	Data type: Unsigned32
	Can be changed: -	Scaling: -	Dyn. index: -
	Unit group: -	Unit selection: -	Func. diagram: 7240
	Min	Max	Factory setting
	-	-	-
Description:	Display parameter for output Q of instance DFR 1 of the D flipflop.		
r20205	BO: DFR 1 inverted output QN / DFR 1 inv outp QN		
	Access level: 3	Calculated: -	Data type: Unsigned32
	Can be changed: -	Scaling: -	Dyn. index: -
	Unit group: -	Unit selection: -	Func. diagram: 7240
	Min	Max	Factory setting
	-	-	-
Description:	Display parameter for the inverted output QN of instance DFR 1 of the D flipflop.		
p20206	DFR 1 runtime group / DFR 1 RTG		
	Access level: 3	Calculated: -	Data type: Integer16
	Can be changed: T	Scaling: -	Dyn. index: -
	Unit group: -	Unit selection: -	Func. diagram: 7240
	Min	Max	Factory setting
	1	9999	9999
Description:	Setting parameter for the runtime group in which instance DFR 1 of the D flipflop is to be called.		
Value:	1: Runtime group 1 2: Runtime group 2 3: Runtime group 3 4: Runtime group 4 5: Runtime group 5 6: Runtime group 6 9999: Do not calculate		
p20207	DFR 1 run sequence / DFR 1 RunSeq		
	Access level: 3	Calculated: -	Data type: Unsigned16
	Can be changed: T	Scaling: -	Dyn. index: -
	Unit group: -	Unit selection: -	Func. diagram: 7240
	Min	Max	Factory setting
	0	32000	560
Description:	Setting parameter for the runtime group of instance DFR 1 within the runtime group set in p20206.		
Note:	The function blocks with a lower run sequence value are calculated before function blocks with a higher run sequence value.		

p20208[0...1]	BI: BSW 0 inputs / BSW 0 inputs		
	Access level: 3	Calculated: -	Data type: U32 / Binary
	Can be changed: T	Scaling: -	Dyn. index: -
	Unit group: -	Unit selection: -	Func. diagram: 7250
	Min	Max	Factory setting
	-	-	0
Description:	Sets the signal source of input quantities I0 and I1 of instance BSW 0 of the binary changeover switch.		
Index:	[0] = Input I0 [1] = Input I1		
p20209	BI: BSW 0 switch setting I / BSW 0 sw_setting		
	Access level: 3	Calculated: -	Data type: U32 / Binary
	Can be changed: T	Scaling: -	Dyn. index: -
	Unit group: -	Unit selection: -	Func. diagram: 7250
	Min	Max	Factory setting
	-	-	0
Description:	Sets the signal source of the switch setting I of instance BSW 0 of the binary changeover switch.		
r20210	BO: BSW 0 output Q / BSW 0 output Q		
	Access level: 3	Calculated: -	Data type: Unsigned32
	Can be changed: -	Scaling: -	Dyn. index: -
	Unit group: -	Unit selection: -	Func. diagram: 7250
	Min	Max	Factory setting
	-	-	-
Description:	Display parameter for output quantity Q of instance BSW 0 of the binary changeover switch.		
p20211	BSW 0 runtime group / BSW 0 RTG		
	Access level: 3	Calculated: -	Data type: Integer16
	Can be changed: T	Scaling: -	Dyn. index: -
	Unit group: -	Unit selection: -	Func. diagram: 7250
	Min	Max	Factory setting
	1	9999	9999
Description:	Setting parameter for the runtime group in which the instance BSW 0 of the binary changeover switch is to be called.		
Value:	1: Runtime group 1 2: Runtime group 2 3: Runtime group 3 4: Runtime group 4 5: Runtime group 5 6: Runtime group 6 9999: Do not calculate		
p20212	BSW 0 run sequence / BSW 0 RunSeq		
	Access level: 3	Calculated: -	Data type: Unsigned16
	Can be changed: T	Scaling: -	Dyn. index: -
	Unit group: -	Unit selection: -	Func. diagram: 7250
	Min	Max	Factory setting
	0	7999	580
Description:	Setting parameter for the run sequence of instance BSW 0 within the runtime group set in p20211.		
Note:	The function blocks with a lower run sequence value are calculated before function blocks with a higher run sequence value.		

p20213[0...1]	BI: BSW 1 inputs / BSW 1 inputs		
	Access level: 3	Calculated: -	Data type: U32 / Binary
	Can be changed: T	Scaling: -	Dyn. index: -
	Unit group: -	Unit selection: -	Func. diagram: 7250
	Min	Max	Factory setting
	-	-	0
Description:	Sets the signal source of input quantities I0 and I1 of instance BSW 1 of the binary changeover switch.		
Index:	[0] = Input I0 [1] = Input I1		
p20214	BI: BSW 1 switch setting I / BSW 1 sw_setting		
	Access level: 3	Calculated: -	Data type: U32 / Binary
	Can be changed: T	Scaling: -	Dyn. index: -
	Unit group: -	Unit selection: -	Func. diagram: 7250
	Min	Max	Factory setting
	-	-	0
Description:	Sets the signal source of the switch setting I of instance BSW 1 of the binary changeover switch.		
r20215	BO: BSW 1 output Q / BSW 1 output Q		
	Access level: 3	Calculated: -	Data type: Unsigned32
	Can be changed: -	Scaling: -	Dyn. index: -
	Unit group: -	Unit selection: -	Func. diagram: 7250
	Min	Max	Factory setting
	-	-	-
Description:	Display parameter for output quantity Q of instance BSW 1 of the binary changeover switch.		
p20216	BSW 1 runtime group / BSW 1 RTG		
	Access level: 3	Calculated: -	Data type: Integer16
	Can be changed: T	Scaling: -	Dyn. index: -
	Unit group: -	Unit selection: -	Func. diagram: 7250
	Min	Max	Factory setting
	1	9999	9999
Description:	Setting parameter for the runtime group in which the instance BSW 1 of the binary changeover switch is to be called.		
Value:	1: Runtime group 1 2: Runtime group 2 3: Runtime group 3 4: Runtime group 4 5: Runtime group 5 6: Runtime group 6 9999: Do not calculate		
p20217	BSW 1 run sequence / BSW 1 RunSeq		
	Access level: 3	Calculated: -	Data type: Unsigned16
	Can be changed: T	Scaling: -	Dyn. index: -
	Unit group: -	Unit selection: -	Func. diagram: 7250
	Min	Max	Factory setting
	0	7999	590
Description:	Setting parameter for the run sequence of instance BSW 1 within the runtime group set in p20216.		
Note:	The function blocks with a lower run sequence value are calculated before function blocks with a higher run sequence value.		

p20218[0...1]	CI: NSW 0 inputs / NSW 0 inputs		
	Access level: 3	Calculated: -	Data type: U32 / FloatingPoint32
	Can be changed: T	Scaling: PERCENT	Dyn. index: -
	Unit group: -	Unit selection: -	Func. diagram: 7250
	Min	Max	Factory setting
	-	-	0
Description:	Sets the signal source of input quantities X0 and X1 of instance NSW 0 of the numeric changeover switch.		
Index:	[0] = Input X0 [1] = Input X1		
p20219	BI: NSW 0 switch setting I / NSW 0 sw_setting		
	Access level: 3	Calculated: -	Data type: U32 / Binary
	Can be changed: T	Scaling: -	Dyn. index: -
	Unit group: -	Unit selection: -	Func. diagram: 7250
	Min	Max	Factory setting
	-	-	0
Description:	Sets the signal source of the switch setting I of instance NSW 0 of the numeric changeover switch.		
r20220	CO: NSW 0 output Y / NSW 0 output Y		
	Access level: 3	Calculated: -	Data type: FloatingPoint32
	Can be changed: -	Scaling: PERCENT	Dyn. index: -
	Unit group: -	Unit selection: -	Func. diagram: 7250
	Min	Max	Factory setting
	-	-	-
Description:	Display parameter for output quantity Y of instance NSW 0 of the numeric changeover switch.		
p20221	NSW 0 runtime group / NSW 0 RTG		
	Access level: 3	Calculated: -	Data type: Integer16
	Can be changed: T	Scaling: -	Dyn. index: -
	Unit group: -	Unit selection: -	Func. diagram: 7250
	Min	Max	Factory setting
	5	9999	9999
Description:	Setting parameter for the runtime group in which the instance NSW 0 of the numeric changeover switch is to be called.		
Value:	5: Runtime group 5 6: Runtime group 6 9999: Do not calculate		
p20222	NSW 0 run sequence / NSW 0 RunSeq		
	Access level: 3	Calculated: -	Data type: Unsigned16
	Can be changed: T	Scaling: -	Dyn. index: -
	Unit group: -	Unit selection: -	Func. diagram: 7250
	Min	Max	Factory setting
	0	32000	610
Description:	Setting parameter for the run sequence of instance NSW 0 within the runtime group set in p20221.		
Note:	The function blocks with a lower run sequence value are calculated before function blocks with a higher run sequence value.		

p20223[0...1]	CI: NSW 1 inputs / NSW 1 inputs		
	Access level: 3	Calculated: -	Data type: U32 / FloatingPoint32
	Can be changed: T	Scaling: PERCENT	Dyn. index: -
	Unit group: -	Unit selection: -	Func. diagram: 7250
	Min	Max	Factory setting
	-	-	0
Description:	Sets the signal source of input quantities X0 and X1 of instance NSW 1 of the numeric changeover switch.		
Index:	[0] = Input X0 [1] = Input X1		
p20224	BI: NSW 1 switch setting I / NSW 1 sw_setting		
	Access level: 3	Calculated: -	Data type: U32 / Binary
	Can be changed: T	Scaling: -	Dyn. index: -
	Unit group: -	Unit selection: -	Func. diagram: 7250
	Min	Max	Factory setting
	-	-	0
Description:	Sets the signal source of the switch setting I of instance NSW 1 of the numeric changeover switch.		
r20225	CO: NSW 1 output Y / NSW 1 output Y		
	Access level: 3	Calculated: -	Data type: FloatingPoint32
	Can be changed: -	Scaling: PERCENT	Dyn. index: -
	Unit group: -	Unit selection: -	Func. diagram: 7250
	Min	Max	Factory setting
	-	-	-
Description:	Display parameter for output quantity Y of instance NSW 1 of the numeric changeover switch.		
p20226	NSW 1 runtime group / NSW 1 RTG		
	Access level: 3	Calculated: -	Data type: Integer16
	Can be changed: T	Scaling: -	Dyn. index: -
	Unit group: -	Unit selection: -	Func. diagram: 7250
	Min	Max	Factory setting
	5	9999	9999
Description:	Setting parameter for the runtime group in which the instance NSW 1 of the numeric changeover switch is to be called.		
Value:	5: Runtime group 5 6: Runtime group 6 9999: Do not calculate		
p20227	NSW 1 run sequence / NSW 1 RunSeq		
	Access level: 3	Calculated: -	Data type: Unsigned16
	Can be changed: T	Scaling: -	Dyn. index: -
	Unit group: -	Unit selection: -	Func. diagram: 7250
	Min	Max	Factory setting
	0	32000	620
Description:	Setting parameter for the run sequence of instance NSW 1 within the runtime group set in p20226.		
Note:	The function blocks with a lower run sequence value are calculated before function blocks with a higher run sequence value.		

p20228	CI: LIM 0 input X / LIM 0 input X		
	Access level: 3	Calculated: -	Data type: U32 / FloatingPoint32
	Can be changed: T	Scaling: PERCENT	Dyn. index: -
	Unit group: -	Unit selection: -	Func. diagram: 7260
	Min	Max	Factory setting
	-	-	0

Description: Sets the signal source of input quantity X of instance LIM 0 of the limiter.

p20229	LIM 0 upper limit value LU / LIM 0 upper lim LU		
	Access level: 3	Calculated: -	Data type: FloatingPoint32
	Can be changed: T	Scaling: -	Dyn. index: -
	Unit group: -	Unit selection: -	Func. diagram: 7260
	Min	Max	Factory setting
	-340.28235E36	340.28235E36	0.0000

Description: Setting parameter for the upper limit value LU of instance LIM 0 of the limiter.

p20230	LIM 0 lower limit value LL / LIM 0 lower lim LL		
	Access level: 3	Calculated: -	Data type: FloatingPoint32
	Can be changed: T	Scaling: -	Dyn. index: -
	Unit group: -	Unit selection: -	Func. diagram: 7260
	Min	Max	Factory setting
	-340.28235E36	340.28235E36	0.0000

Description: Setting parameter for the lower limit value LL of instance LIM 0 of the limiter.

r20231	CO: LIM 0 output Y / LIM 0 output Y		
	Access level: 3	Calculated: -	Data type: FloatingPoint32
	Can be changed: -	Scaling: PERCENT	Dyn. index: -
	Unit group: -	Unit selection: -	Func. diagram: 7260
	Min	Max	Factory setting
	-	-	-

Description: Display parameter for the limited output quantity Y of instance LIM 0 of the limiter.

r20232	BO: LIM 0 input quantity at the upper limit QU / LIM 0 QU		
	Access level: 3	Calculated: -	Data type: Unsigned32
	Can be changed: -	Scaling: -	Dyn. index: -
	Unit group: -	Unit selection: -	Func. diagram: 7260
	Min	Max	Factory setting
	-	-	-

Description: Display parameter of instance LIM 0 of limiter QU (upper limit reached), i.e. QU = 1 for X >= LU.

r20233	BO: LIM 0 input quantity at the lower limit QL / LIM 0 QL		
	Access level: 3	Calculated: -	Data type: Unsigned32
	Can be changed: -	Scaling: -	Dyn. index: -
	Unit group: -	Unit selection: -	Func. diagram: 7260
	Min	Max	Factory setting
	-	-	-

Description: Display parameter of instance LIM 0 of limiter QL (lower limit reached), i.e. QL = 1 for X <= LL.

p20234	LIM 0 runtime group / LIM 0 RTG		
	Access level: 3	Calculated: -	Data type: Integer16
	Can be changed: T	Scaling: -	Dyn. index: -
	Unit group: -	Unit selection: -	Func. diagram: 7260
	Min	Max	Factory setting
	5	9999	9999
Description:	Setting parameter for the runtime group in which instance LIM 0 of the limiter is to be called.		
Value:	5: Runtime group 5 6: Runtime group 6 9999: Do not calculate		
p20235	LIM 0 run sequence / LIM 0 RunSeq		
	Access level: 3	Calculated: -	Data type: Unsigned16
	Can be changed: T	Scaling: -	Dyn. index: -
	Unit group: -	Unit selection: -	Func. diagram: 7260
	Min	Max	Factory setting
	0	32000	640
Description:	Setting parameter for the run sequence of instance LIM 0 within the runtime group set in p20234.		
Note:	The function blocks with a lower run sequence value are calculated before function blocks with a higher run sequence value.		
p20236	CI: LIM 1 input X / LIM 1 input X		
	Access level: 3	Calculated: -	Data type: U32 / FloatingPoint32
	Can be changed: T	Scaling: PERCENT	Dyn. index: -
	Unit group: -	Unit selection: -	Func. diagram: 7260
	Min	Max	Factory setting
	-	-	0
Description:	Sets the signal source of input quantity X of instance LIM 1 of the limiter.		
p20237	LIM 1 upper limit value LU / LIM 1 upper lim LU		
	Access level: 3	Calculated: -	Data type: FloatingPoint32
	Can be changed: T	Scaling: -	Dyn. index: -
	Unit group: -	Unit selection: -	Func. diagram: 7260
	Min	Max	Factory setting
	-340.28235E36	340.28235E36	0.0000
Description:	Setting parameter for the upper limit value LU of instance LIM 1 of the limiter.		
p20238	LIM 1 lower limit value LL / LIM 1 lower lim LL		
	Access level: 3	Calculated: -	Data type: FloatingPoint32
	Can be changed: T	Scaling: -	Dyn. index: -
	Unit group: -	Unit selection: -	Func. diagram: 7260
	Min	Max	Factory setting
	-340.28235E36	340.28235E36	0.0000
Description:	Setting parameter for the lower limit value LL of instance LIM 1 of the limiter.		
r20239	CO: LIM 1 output Y / LIM 1 output Y		
	Access level: 3	Calculated: -	Data type: FloatingPoint32
	Can be changed: -	Scaling: PERCENT	Dyn. index: -
	Unit group: -	Unit selection: -	Func. diagram: 7260
	Min	Max	Factory setting
	-	-	-
Description:	Display parameter for the limited output quantity Y of instance LIM 1 of the limiter.		

r20240	BO: LIM 1 input quantity at the upper limit QU / LIM 1 QU		
	Access level: 3	Calculated: -	Data type: Unsigned32
	Can be changed: -	Scaling: -	Dyn. index: -
	Unit group: -	Unit selection: -	Func. diagram: 7260
	Min	Max	Factory setting
	-	-	-
Description:	Display parameter of instance LIM 1 of limiter QU (upper limit reached), i.e. QU = 1 for X >= LU.		
r20241	BO: LIM 1 input quantity at the lower limit QL / LIM 1 QL		
	Access level: 3	Calculated: -	Data type: Unsigned32
	Can be changed: -	Scaling: -	Dyn. index: -
	Unit group: -	Unit selection: -	Func. diagram: 7260
	Min	Max	Factory setting
	-	-	-
Description:	Display parameter of instance LIM 1 of limiter QL (lower limit reached), i.e. QL = 1 for X <= LL.		
p20242	LIM 1 runtime group / LIM 1 RTG		
	Access level: 3	Calculated: -	Data type: Integer16
	Can be changed: T	Scaling: -	Dyn. index: -
	Unit group: -	Unit selection: -	Func. diagram: 7260
	Min	Max	Factory setting
	5	9999	9999
Description:	Setting parameter for the runtime group in which instance LIM 1 of the limiter is to be called.		
Value:	5: Runtime group 5 6: Runtime group 6 9999: Do not calculate		
p20243	LIM 1 run sequence / LIM 1 RunSeq		
	Access level: 3	Calculated: -	Data type: Unsigned16
	Can be changed: T	Scaling: -	Dyn. index: -
	Unit group: -	Unit selection: -	Func. diagram: 7260
	Min	Max	Factory setting
	0	32000	650
Description:	Setting parameter for the run sequence of instance LIM 1 within the runtime group set in p20242.		
Note:	The function blocks with a lower run sequence value are calculated before function blocks with a higher run sequence value.		
p20244[0...1]	CI: PT1 0 inputs / PT1 0 inputs		
	Access level: 3	Calculated: -	Data type: U32 / FloatingPoint32
	Can be changed: T	Scaling: PERCENT	Dyn. index: -
	Unit group: -	Unit selection: -	Func. diagram: 7262
	Min	Max	Factory setting
	-	-	0
Description:	Sets the signal source of input quantity X and of setting value SV of instance PT1 0 of the smoothing element.		
Index:	[0] = Input X [1] = Setting value SV		

p20245	BI: PT1 0 accept setting value S / PT1 0 acc set val		
	Access level: 3	Calculated: -	Data type: U32 / Binary
	Can be changed: T	Scaling: -	Dyn. index: -
	Unit group: -	Unit selection: -	Func. diagram: 7262
	Min	Max	Factory setting
	-	-	0
Description:	Sets the signal source for the "accept setting value" signal of instant PT1 0 of the smoothing element.		
p20246	PT1 0 smoothing time constant in ms / PT1 0 T_smooth ms		
	Access level: 3	Calculated: -	Data type: FloatingPoint32
	Can be changed: T	Scaling: -	Dyn. index: -
	Unit group: -	Unit selection: -	Func. diagram: 7262
	Min	Max	Factory setting
	0.00	340.28235E36	0.00
Description:	Sets the smoothing time constant T in milliseconds of instance PT1 0 of the smoothing element.		
r20247	CO: PT1 0 output Y / PT1 0 output Y		
	Access level: 3	Calculated: -	Data type: FloatingPoint32
	Can be changed: -	Scaling: PERCENT	Dyn. index: -
	Unit group: -	Unit selection: -	Func. diagram: 7262
	Min	Max	Factory setting
	-	-	-
Description:	Display parameter for the smoothed output quantity Y of instance PT1 0 of the smoothing element.		
p20248	PT1 0 runtime group / PT1 0 RTG		
	Access level: 3	Calculated: -	Data type: Integer16
	Can be changed: T	Scaling: -	Dyn. index: -
	Unit group: -	Unit selection: -	Func. diagram: 7262
	Min	Max	Factory setting
	5	9999	9999
Description:	Setting parameter for the runtime group in which instance PT1 0 of the smoothing element is to be called.		
Value:	5: Runtime group 5 6: Runtime group 6 9999: Do not calculate		
p20249	PT1 0 run sequence / PT1 0 RunSeq		
	Access level: 3	Calculated: -	Data type: Unsigned16
	Can be changed: T	Scaling: -	Dyn. index: -
	Unit group: -	Unit selection: -	Func. diagram: 7262
	Min	Max	Factory setting
	0	32000	670
Description:	Setting parameter for the run sequence of instance PT1 0 within the runtime group set in p20248.		
Note:	The function blocks with a lower run sequence value are calculated before function blocks with a higher run sequence value.		
p20250[0...1]	CI: PT1 1 inputs / PT1 1 inputs		
	Access level: 3	Calculated: -	Data type: U32 / FloatingPoint32
	Can be changed: T	Scaling: PERCENT	Dyn. index: -
	Unit group: -	Unit selection: -	Func. diagram: 7262
	Min	Max	Factory setting
	-	-	0
Description:	Sets the signal source of input quantity X and of setting value SV of instance PT1 1 of the smoothing element.		

Index: [0] = Input X
[1] = Setting value SV

p20251	BI: PT1 1 accept setting value S / PT1 1 acc set val		
Access level: 3	Calculated: -	Data type: U32 / Binary	
Can be changed: T	Scaling: -	Dyn. index: -	
Unit group: -	Unit selection: -	Func. diagram: 7262	
Min	Max	Factory setting	
-	-	0	

Description: Sets the signal source for the "accept setting value" signal of instant PT1 1 of the smoothing element.

p20252	PT1 1 smoothing time constant in ms / PT1 1 T_smooth ms		
Access level: 3	Calculated: -	Data type: FloatingPoint32	
Can be changed: T	Scaling: -	Dyn. index: -	
Unit group: -	Unit selection: -	Func. diagram: 7262	
Min	Max	Factory setting	
0.00	340.28235E36	0.00	

Description: Sets the smoothing time constant T in milliseconds of instance PT1 1 of the smoothing element.

r20253	CO: PT1 1 output Y / PT1 1 output Y		
Access level: 3	Calculated: -	Data type: FloatingPoint32	
Can be changed: -	Scaling: PERCENT	Dyn. index: -	
Unit group: -	Unit selection: -	Func. diagram: 7262	
Min	Max	Factory setting	
-	-	-	

Description: Display parameter for the smoothed output quantity Y of instance PT1 1 of the smoothing element.

p20254	PT1 1 runtime group / PT1 1 RTG		
Access level: 3	Calculated: -	Data type: Integer16	
Can be changed: T	Scaling: -	Dyn. index: -	
Unit group: -	Unit selection: -	Func. diagram: 7262	
Min	Max	Factory setting	
5	9999	9999	

Description: Setting parameter for the runtime group in which instance PT1 1 of the smoothing element is to be called.

Value:
5: Runtime group 5
6: Runtime group 6
9999: Do not calculate

p20255	PT1 1 run sequence / PT1 1 RunSeq		
Access level: 3	Calculated: -	Data type: Unsigned16	
Can be changed: T	Scaling: -	Dyn. index: -	
Unit group: -	Unit selection: -	Func. diagram: 7262	
Min	Max	Factory setting	
0	32000	680	

Description: Setting parameter for the run sequence of instance PT1 1 within the runtime group set in p20254.

Note: The function blocks with a lower run sequence value are calculated before function blocks with a higher run sequence value.

p20256[0...1]	CI: INT 0 inputs / INT 0 inputs		
	Access level: 3	Calculated: -	Data type: U32 / FloatingPoint32
	Can be changed: T	Scaling: PERCENT	Dyn. index: -
	Unit group: -	Unit selection: -	Func. diagram: 7264
	Min	Max	Factory setting
	-	-	0
Description:	Sets the signal source of input quantity X and of setting value SV of instance INT 0 of the integrator.		
Index:	[0] = Input X [1] = Setting value SV		
p20257	INT 0 upper limit value LU / INT 0 upper lim LU		
	Access level: 3	Calculated: -	Data type: FloatingPoint32
	Can be changed: T	Scaling: -	Dyn. index: -
	Unit group: -	Unit selection: -	Func. diagram: 7264
	Min	Max	Factory setting
	-340.28235E36	340.28235E36	0.0000
Description:	Sets the upper limit value LU of instance INT 0 of the integrator.		
p20258	INT 0 lower limit value LL / INT 0 lower lim LL		
	Access level: 3	Calculated: -	Data type: FloatingPoint32
	Can be changed: T	Scaling: -	Dyn. index: -
	Unit group: -	Unit selection: -	Func. diagram: 7264
	Min	Max	Factory setting
	-340.28235E36	340.28235E36	0.0000
Description:	Sets the lower limit value LL of instance INT 0 of the integrator.		
p20259	INT 0 integrating time constant in ms / INT 0 T_Integr ms		
	Access level: 3	Calculated: -	Data type: FloatingPoint32
	Can be changed: T	Scaling: -	Dyn. index: -
	Unit group: -	Unit selection: -	Func. diagram: 7264
	Min	Max	Factory setting
	0.00	340.28235E36	0.00
Description:	Sets the integrating time constant Ti in milliseconds of instance INT 0 of the integrator.		
p20260	BI: INT 0 accept setting value S / INT 0 acc set val		
	Access level: 3	Calculated: -	Data type: U32 / Binary
	Can be changed: T	Scaling: -	Dyn. index: -
	Unit group: -	Unit selection: -	Func. diagram: 7264
	Min	Max	Factory setting
	-	-	0
Description:	Sets the signal source for the "accept setting value" signal of instant INT 0 of the integrator.		
r20261	CO: INT 0 output Y / INT 0 output Y		
	Access level: 3	Calculated: -	Data type: FloatingPoint32
	Can be changed: -	Scaling: PERCENT	Dyn. index: -
	Unit group: -	Unit selection: -	Func. diagram: 7264
	Min	Max	Factory setting
	-	-	-
Description:	Display parameter for output quantity Y of instance INT 0 of the integrator. If LL >= LU, then the output quantity Y = LU.		

r20262	BO: INT 0 integrator at the upper limit QU / INT 0 QU		
	Access level: 3	Calculated: -	Data type: Unsigned32
	Can be changed: -	Scaling: -	Dyn. index: -
	Unit group: -	Unit selection: -	Func. diagram: 7264
	Min	Max	Factory setting
	-	-	-
Description:	Display parameter for the signal QU that output quantity Y of instance INT 0 of the integrator has reached the upper limit value LU.		
r20263	BO: INT 0 integrator at the lower limit QL / INT 0 QL		
	Access level: 3	Calculated: -	Data type: Unsigned32
	Can be changed: -	Scaling: -	Dyn. index: -
	Unit group: -	Unit selection: -	Func. diagram: 7264
	Min	Max	Factory setting
	-	-	-
Description:	Display parameter for the signal QL that output quantity Y of instance INT 0 of the integrator has reached the lower limit value LL.		
p20264	INT 0 runtime group / INT 0 RTG		
	Access level: 3	Calculated: -	Data type: Integer16
	Can be changed: T	Scaling: -	Dyn. index: -
	Unit group: -	Unit selection: -	Func. diagram: 7264
	Min	Max	Factory setting
	5	9999	9999
Description:	Setting parameter for the runtime group in which instance INT 0 of the integrator is to be called.		
Value:	5: Runtime group 5 6: Runtime group 6 9999: Do not calculate		
p20265	INT 0 run sequence / INT 0 RunSeq		
	Access level: 3	Calculated: -	Data type: Unsigned16
	Can be changed: T	Scaling: -	Dyn. index: -
	Unit group: -	Unit selection: -	Func. diagram: 7264
	Min	Max	Factory setting
	0	32000	700
Description:	Setting parameter for the run sequence of instance INT 0 within the runtime group set in p20264.		
Note:	The function blocks with a lower run sequence value are calculated before function blocks with a higher run sequence value.		
p20266	CI: LVM 0 input X / LVM 0 input X		
	Access level: 3	Calculated: -	Data type: U32 / FloatingPoint32
	Can be changed: T	Scaling: PERCENT	Dyn. index: -
	Unit group: -	Unit selection: -	Func. diagram: 7270
	Min	Max	Factory setting
	-	-	0
Description:	Sets the signal source of input quantity X of instance LVM 0 of the double-sided limiter.		

2 Parameters

2.2 List of parameters

p20267	LVM 0 interval average value M / LVM 0 avg value M		
	Access level: 3	Calculated: -	Data type: FloatingPoint32
	Can be changed: T	Scaling: -	Dyn. index: -
	Unit group: -	Unit selection: -	Func. diagram: 7270
	Min	Max	Factory setting
	-340.28235E36	340.28235E36	0.0000
Description:	Setting parameter for the interval average M of instance LVM 0 of the double-sided limiter.		

p20268	LVM 0 interval limit L / LVM 0 limit L		
	Access level: 3	Calculated: -	Data type: FloatingPoint32
	Can be changed: T	Scaling: -	Dyn. index: -
	Unit group: -	Unit selection: -	Func. diagram: 7270
	Min	Max	Factory setting
	-340.28235E36	340.28235E36	0.0000
Description:	Setting parameter for the interval limit L of instance LVM 0 of the double-sided limiter.		

p20269	LVM 0 hyst HY / LVM 0 hyst HY		
	Access level: 3	Calculated: -	Data type: FloatingPoint32
	Can be changed: T	Scaling: -	Dyn. index: -
	Unit group: -	Unit selection: -	Func. diagram: 7270
	Min	Max	Factory setting
	-340.28235E36	340.28235E36	0.0000
Description:	Setting parameter for hysteresis HY of instance LVM 0 of the double-sided limiter.		

r20270	BO: LVM 0 input quantity above interval QU / LVM 0 X above QU		
	Access level: 3	Calculated: -	Data type: Unsigned32
	Can be changed: -	Scaling: -	Dyn. index: -
	Unit group: -	Unit selection: -	Func. diagram: 7270
	Min	Max	Factory setting
	-	-	-
Description:	Display parameter of instance LVM 0 of the double-sided limiter that input quantity X was at least once $X > M + L$ and X is $\geq M + L - HY$.		

r20271	BO: LVM 0 input quantity within interval QM / LVM 0 X within QM		
	Access level: 3	Calculated: -	Data type: Unsigned32
	Can be changed: -	Scaling: -	Dyn. index: -
	Unit group: -	Unit selection: -	Func. diagram: 7270
	Min	Max	Factory setting
	-	-	-
Description:	Display parameter of instance LVM 0 of the double-sided limiter that the input quantity X lies within the interval.		

r20272	BO: LVM 0 input quantity below interval QL / LVM 0 X below QL		
	Access level: 3	Calculated: -	Data type: Unsigned32
	Can be changed: -	Scaling: -	Dyn. index: -
	Unit group: -	Unit selection: -	Func. diagram: 7270
	Min	Max	Factory setting
	-	-	-
Description:	Display parameter of instance LVM 0 of the double-sided limiter that input quantity X was at least once $X < M - L$ and X is $\leq M - L + HY$.		

p20273	LVM 0 runtime group / LVM 0 RTG		
	Access level: 3	Calculated: -	Data type: Integer16
	Can be changed: T	Scaling: -	Dyn. index: -
	Unit group: -	Unit selection: -	Func. diagram: 7270
	Min	Max	Factory setting
	5	9999	9999
Description:	Setting parameter for the runtime group in which instance LVM 0 of the double-sided limiter is to be called.		
Value:	5: Runtime group 5 6: Runtime group 6 9999: Do not calculate		
p20274	LVM 0 run sequence / LVM 0 RunSeq		
	Access level: 3	Calculated: -	Data type: Unsigned16
	Can be changed: T	Scaling: -	Dyn. index: -
	Unit group: -	Unit selection: -	Func. diagram: 7270
	Min	Max	Factory setting
	0	7999	720
Description:	Setting parameter for the run sequence of instance LVM 0 within the runtime group set in p20273.		
Note:	The function blocks with a lower run sequence value are calculated before function blocks with a higher run sequence value.		
p20275	CI: LVM 1 input X / LVM 1 input X		
	Access level: 3	Calculated: -	Data type: U32 / FloatingPoint32
	Can be changed: T	Scaling: PERCENT	Dyn. index: -
	Unit group: -	Unit selection: -	Func. diagram: 7270
	Min	Max	Factory setting
	-	-	0
Description:	Sets the signal source of input quantity X of instance LVM 1 of the double-sided limiter.		
p20276	LVM 1 interval average value M / LVM 1 avg value M		
	Access level: 3	Calculated: -	Data type: FloatingPoint32
	Can be changed: T	Scaling: -	Dyn. index: -
	Unit group: -	Unit selection: -	Func. diagram: 7270
	Min	Max	Factory setting
	-340.28235E36	340.28235E36	0.0000
Description:	Setting parameter for the interval average M of instance LVM 1 of the double-sided limiter.		
p20277	LVM 1 interval limit L / LVM 1 limit L		
	Access level: 3	Calculated: -	Data type: FloatingPoint32
	Can be changed: T	Scaling: -	Dyn. index: -
	Unit group: -	Unit selection: -	Func. diagram: 7270
	Min	Max	Factory setting
	-340.28235E36	340.28235E36	0.0000
Description:	Setting parameter for the interval limit L of instance LVM 1 of the double-sided limiter.		
p20278	LVM 1 hyst HY / LVM 1 hyst HY		
	Access level: 3	Calculated: -	Data type: FloatingPoint32
	Can be changed: T	Scaling: -	Dyn. index: -
	Unit group: -	Unit selection: -	Func. diagram: 7270
	Min	Max	Factory setting
	-340.28235E36	340.28235E36	0.0000
Description:	Setting parameter for hysteresis HY of instance LVM 1 of the double-sided limiter.		

2 Parameters

2.2 List of parameters

r20279	BO: LVM 1 input quantity above interval QU / LVM 1 X above QU		
	Access level: 3	Calculated: -	Data type: Unsigned32
	Can be changed: -	Scaling: -	Dyn. index: -
	Unit group: -	Unit selection: -	Func. diagram: 7270
	Min	Max	Factory setting
	-	-	-
Description:	Display parameter of instance LVM 1 of the double-sided limiter that input quantity X was at least once $X > M + L$ and X is $\geq M + L - HY$.		
r20280	BO: LVM 1 input quantity within interval QM / LVM 1 X within QM		
	Access level: 3	Calculated: -	Data type: Unsigned32
	Can be changed: -	Scaling: -	Dyn. index: -
	Unit group: -	Unit selection: -	Func. diagram: 7270
	Min	Max	Factory setting
	-	-	-
Description:	Display parameter of instance LVM 1 of the double-sided limiter that the input quantity X lies within the interval.		
r20281	BO: LVM 1 input quantity below interval QL / LVM 1 X below QL		
	Access level: 3	Calculated: -	Data type: Unsigned32
	Can be changed: -	Scaling: -	Dyn. index: -
	Unit group: -	Unit selection: -	Func. diagram: 7270
	Min	Max	Factory setting
	-	-	-
Description:	Display parameter of instance LVM 1 of the double-sided limiter that input quantity X was at least once $X < M - L$ and X is $\leq M - L + HY$.		
p20282	LVM 1 runtime group / LVM 1 RTG		
	Access level: 3	Calculated: -	Data type: Integer16
	Can be changed: T	Scaling: -	Dyn. index: -
	Unit group: -	Unit selection: -	Func. diagram: 7270
	Min	Max	Factory setting
	5	9999	9999
Description:	Setting parameter for the runtime group in which instance LVM 1 of the double-sided limiter is to be called.		
Value:	5: Runtime group 5 6: Runtime group 6 9999: Do not calculate		
p20283	LVM 1 run sequence / LVM 1 RunSeq		
	Access level: 3	Calculated: -	Data type: Unsigned16
	Can be changed: T	Scaling: -	Dyn. index: -
	Unit group: -	Unit selection: -	Func. diagram: 7270
	Min	Max	Factory setting
	0	7999	730
Description:	Setting parameter for the run sequence of instance LVM 1 within the runtime group set in p20282.		
Note:	The function blocks with a lower run sequence value are calculated before function blocks with a higher run sequence value.		

p20284	CI: DIF 0 input X / DIF 0 input X		
	Access level: 3	Calculated: -	Data type: U32 / FloatingPoint32
	Can be changed: T	Scaling: PERCENT	Dyn. index: -
	Unit group: -	Unit selection: -	Func. diagram: 7264
	Min	Max	Factory setting
	-	-	0

Description: Sets the signal source of input quantity X of instance DIF 0 of the differentiating element.

p20285	DIF 0 differentiating time constant in ms / DIF 0 T_diff ms		
	Access level: 3	Calculated: -	Data type: FloatingPoint32
	Can be changed: T	Scaling: -	Dyn. index: -
	Unit group: -	Unit selection: -	Func. diagram: 7264
	Min	Max	Factory setting
	0.00	340.28235E36	0.00

Description: Sets the differentiating time constant Td in milliseconds of instance DIF 0 of the differentiating element.

r20286	CO: DIF 0 output Y / DIF 0 output Y		
	Access level: 3	Calculated: -	Data type: FloatingPoint32
	Can be changed: -	Scaling: PERCENT	Dyn. index: -
	Unit group: -	Unit selection: -	Func. diagram: 7264
	Min	Max	Factory setting
	-	-	-

Description: Display parameter for output quantity Y of instance DIF 0 of the differentiating element.

p20287	DIF 0 runtime group / DIF 0 RTG		
	Access level: 3	Calculated: -	Data type: Integer16
	Can be changed: T	Scaling: -	Dyn. index: -
	Unit group: -	Unit selection: -	Func. diagram: 7264
	Min	Max	Factory setting
	5	9999	9999

Description: Setting parameter for the runtime group in which instance DIF 0 of the differentiating element is to be called.

Value:
 5: Runtime group 5
 6: Runtime group 6
 9999: Do not calculate

p20288	DIF 0 run sequence / DIF 0 RunSeq		
	Access level: 3	Calculated: -	Data type: Unsigned16
	Can be changed: T	Scaling: -	Dyn. index: -
	Unit group: -	Unit selection: -	Func. diagram: 7264
	Min	Max	Factory setting
	0	32000	750

Description: Setting parameter for the run sequence of instance DIF 0 within the runtime group set in p20287.

Note: The function blocks with a lower run sequence value are calculated before function blocks with a higher run sequence value.

p20300	BI: NOT 4 input I / NOT 4 input I		
	Access level: 3	Calculated: -	Data type: U32 / Binary
	Can be changed: T	Scaling: -	Dyn. index: -
	Unit group: -	Unit selection: -	Func. diagram: 7216
	Min	Max	Factory setting
	-	-	0

Description: Sets the signal source of input quantity I of instance NOT 4 of the inverter.

r20301	BO: NOT 4 inverted output / NOT 4 inv output		
	Access level: 3	Calculated: -	Data type: Unsigned32
	Can be changed: -	Scaling: -	Dyn. index: -
	Unit group: -	Unit selection: -	Func. diagram: 7216
	Min	Max	Factory setting
	-	-	-
Description:	Display parameter for the inverted output of instance NOT 4 of the inverter.		
p20302	NOT 4 runtime group / NOT 4 RTG		
	Access level: 3	Calculated: -	Data type: Integer16
	Can be changed: T	Scaling: -	Dyn. index: -
	Unit group: -	Unit selection: -	Func. diagram: 7216
	Min	Max	Factory setting
	1	9999	9999
Description:	Setting parameter for the runtime group in which the instance NOT 4 of the inverter is to be called.		
Value:	1: Runtime group 1 2: Runtime group 2 3: Runtime group 3 4: Runtime group 4 5: Runtime group 5 6: Runtime group 6 9999: Do not calculate		
p20303	NOT 4 run sequence / NOT 4 RunSeq		
	Access level: 3	Calculated: -	Data type: Unsigned16
	Can be changed: T	Scaling: -	Dyn. index: -
	Unit group: -	Unit selection: -	Func. diagram: 7216
	Min	Max	Factory setting
	0	32000	770
Description:	Setting parameter for the run sequence of instance NOT 4 within the runtime group set in p20302.		
Note:	The function blocks with a lower run sequence value are calculated before function blocks with a higher run sequence value.		
p20304	BI: NOT 5 input I / NOT 5 input I		
	Access level: 3	Calculated: -	Data type: U32 / Binary
	Can be changed: T	Scaling: -	Dyn. index: -
	Unit group: -	Unit selection: -	Func. diagram: 7216
	Min	Max	Factory setting
	-	-	0
Description:	Sets the signal source of input quantity I of instance NOT 5 of the inverter.		
r20305	BO: NOT 5 inverted output / NOT 5 inv output		
	Access level: 3	Calculated: -	Data type: Unsigned32
	Can be changed: -	Scaling: -	Dyn. index: -
	Unit group: -	Unit selection: -	Func. diagram: 7216
	Min	Max	Factory setting
	-	-	-
Description:	Display parameter for the inverted output of instance NOT 5 of the inverter.		

p20306	NOT 5 runtime group / NOT 5 RTG		
	Access level: 3	Calculated: -	Data type: Integer16
	Can be changed: T	Scaling: -	Dyn. index: -
	Unit group: -	Unit selection: -	Func. diagram: 7216
	Min	Max	Factory setting
	1	9999	9999
Description:	Setting parameter for the runtime group in which the instance NOT 5 of the inverter is to be called.		
Value:	1: Runtime group 1 2: Runtime group 2 3: Runtime group 3 4: Runtime group 4 5: Runtime group 5 6: Runtime group 6 9999: Do not calculate		
p20307	NOT 5 run sequence / NOT 5 RunSeq		
	Access level: 3	Calculated: -	Data type: Unsigned16
	Can be changed: T	Scaling: -	Dyn. index: -
	Unit group: -	Unit selection: -	Func. diagram: 7216
	Min	Max	Factory setting
	0	32000	780
Description:	Setting parameter for the run sequence of instance NOT 5 within the runtime group set in p20306.		
Note:	The function blocks with a lower run sequence value are calculated before function blocks with a higher run sequence value.		
p20308[0...3]	CI: ADD 2 inputs / ADD 2 inputs		
	Access level: 3	Calculated: -	Data type: U32 / FloatingPoint32
	Can be changed: T	Scaling: PERCENT	Dyn. index: -
	Unit group: -	Unit selection: -	Func. diagram: 7220
	Min	Max	Factory setting
	-	-	0
Description:	Sets the signal source of input quantities X0, X1, X2, X3 of instance ADD 2 of the adder.		
Index:	[0] = Input X0 [1] = Input X1 [2] = Input X2 [3] = Input X3		
r20309	CO: ADD 2 output Y / ADD 2 output Y		
	Access level: 3	Calculated: -	Data type: FloatingPoint32
	Can be changed: -	Scaling: PERCENT	Dyn. index: -
	Unit group: -	Unit selection: -	Func. diagram: 7220
	Min	Max	Factory setting
	-	-	-
Description:	Display parameter for the output quantity $Y = X0 + X1 + X2 + X3$ of instance ADD 2 of the adder.		
p20310	ADD 2 runtime group / ADD 2 RTG		
	Access level: 3	Calculated: -	Data type: Integer16
	Can be changed: T	Scaling: -	Dyn. index: -
	Unit group: -	Unit selection: -	Func. diagram: 7220
	Min	Max	Factory setting
	5	9999	9999
Description:	Setting parameter for the runtime group in which the instance ADD 2 of the adder is to be called.		

2 Parameters

2.2 List of parameters

Value: 5: Runtime group 5
6: Runtime group 6
9999: Do not calculate

p20311	ADD 2 run sequence / ADD 2 RunSeq	Access level: 3 Can be changed: T Unit group: - Min 0	Calculated: - Scaling: - Unit selection: - Max 32000	Data type: Unsigned16 Dyn. index: - Func. diagram: 7220 Factory setting 800
Description:	Setting parameter for the run sequence of instance ADD 2 within the runtime group set in p20310.			
Note:	The function blocks with a lower run sequence value are calculated before function blocks with a higher run sequence value.			
p20312[0...1]	CI: NCM 0 inputs / NCM 0 inputs	Access level: 3 Can be changed: T Unit group: - Min -	Calculated: - Scaling: PERCENT Unit selection: - Max -	Data type: U32 / FloatingPoint32 Dyn. index: - Func. diagram: 7225 Factory setting 0
Description:	Sets the signal source of input quantities X0 and X1 of instance NCM 0 of the numeric comparator.			
Index:	[0] = Input X0 [1] = Input X1			
r20313	BO: NCM 0 output QU / NCM 0 output QU	Access level: 3 Can be changed: - Unit group: - Min -	Calculated: - Scaling: - Unit selection: - Max -	Data type: Unsigned32 Dyn. index: - Func. diagram: 7225 Factory setting -
Description:	Display parameter for binary quantity QU of instance NCM 0 of the numeric comparator. QU is only set if X0 > X1.			
r20314	BO: NCM 0 output QE / NCM 0 output QE	Access level: 3 Can be changed: - Unit group: - Min -	Calculated: - Scaling: - Unit selection: - Max -	Data type: Unsigned32 Dyn. index: - Func. diagram: 7225 Factory setting -
Description:	Display parameter for binary quantity QE of instance NCM 0 of the numeric comparator. QE is only set if X0 = X1.			
r20315	BO: NCM 0 output QL / NCM 0 output QL	Access level: 3 Can be changed: - Unit group: - Min -	Calculated: - Scaling: - Unit selection: - Max -	Data type: Unsigned32 Dyn. index: - Func. diagram: 7225 Factory setting -
Description:	Display parameter for binary quantity QL of instance NCM 0 of the numeric comparator. QL is only set if X0 < X1.			

p20316	NCM 0 runtime group / NCM 0 RTG		
	Access level: 3	Calculated: -	Data type: Integer16
	Can be changed: T	Scaling: -	Dyn. index: -
	Unit group: -	Unit selection: -	Func. diagram: 7225
	Min	Max	Factory setting
	5	9999	9999
Description:	Setting parameter for the runtime group in which the instance NCM 0 of the numeric comparator is to be called.		
Value:	5: Runtime group 5 6: Runtime group 6 9999: Do not calculate		
p20317	NCM 0 run sequence / NCM 0 RunSeq		
	Access level: 3	Calculated: -	Data type: Unsigned16
	Can be changed: T	Scaling: -	Dyn. index: -
	Unit group: -	Unit selection: -	Func. diagram: 7225
	Min	Max	Factory setting
	0	32000	820
Description:	Setting parameter for the run sequence of instance NCM 0 within the runtime group set in p20316.		
Note:	The function blocks with a lower run sequence value are calculated before function blocks with a higher run sequence value.		
p20318[0...1]	CI: NCM 1 inputs / NCM 1 inputs		
	Access level: 3	Calculated: -	Data type: U32 / FloatingPoint32
	Can be changed: T	Scaling: PERCENT	Dyn. index: -
	Unit group: -	Unit selection: -	Func. diagram: 7225
	Min	Max	Factory setting
	-	-	0
Description:	Sets the signal source of input quantities X0 and X1 of instance NCM 1 of the numeric comparator.		
Index:	[0] = Input X0 [1] = Input X1		
r20319	BO: NCM 1 output QU / NCM 1 output QU		
	Access level: 3	Calculated: -	Data type: Unsigned32
	Can be changed: -	Scaling: -	Dyn. index: -
	Unit group: -	Unit selection: -	Func. diagram: 7225
	Min	Max	Factory setting
	-	-	-
Description:	Display parameter for binary quantity QU of instance NCM 1 of the numeric comparator. QU is only set if X0 > X1.		
r20320	BO: NCM 1 output QE / NCM 1 output QE		
	Access level: 3	Calculated: -	Data type: Unsigned32
	Can be changed: -	Scaling: -	Dyn. index: -
	Unit group: -	Unit selection: -	Func. diagram: 7225
	Min	Max	Factory setting
	-	-	-
Description:	Display parameter for binary quantity QE of instance NCM 1 of the numeric comparator. QE is only set if X0 = X1.		

2 Parameters

2.2 List of parameters

r20321	BO: NCM 1 output QL / NCM 1 output QL		
	Access level: 3	Calculated: -	Data type: Unsigned32
	Can be changed: -	Scaling: -	Dyn. index: -
	Unit group: -	Unit selection: -	Func. diagram: 7225
	Min	Max	Factory setting
	-	-	-
Description:	Display parameter for binary quantity QL of instance NCM 1 of the numeric comparator. QL is only set if $X0 < X1$.		

p20322	NCM 1 runtime group / NCM 1 RTG		
	Access level: 3	Calculated: -	Data type: Integer16
	Can be changed: T	Scaling: -	Dyn. index: -
	Unit group: -	Unit selection: -	Func. diagram: 7225
	Min	Max	Factory setting
	5	9999	9999
Description:	Setting parameter for the runtime group in which the instance NCM 1 of the numeric comparator is to be called.		
Value:	5: Runtime group 5 6: Runtime group 6 9999: Do not calculate		

p20323	NCM 1 run sequence / NCM 1 RunSeq		
	Access level: 3	Calculated: -	Data type: Unsigned16
	Can be changed: T	Scaling: -	Dyn. index: -
	Unit group: -	Unit selection: -	Func. diagram: 7225
	Min	Max	Factory setting
	0	32000	830
Description:	Setting parameter for the run sequence of instance NCM 1 within the runtime group set in p20322.		
Note:	The function blocks with a lower run sequence value are calculated before function blocks with a higher run sequence value.		

p20324[0...1]	BI: RSR 2 inputs / RSR 2 inputs		
	Access level: 3	Calculated: -	Data type: U32 / Binary
	Can be changed: T	Scaling: -	Dyn. index: -
	Unit group: -	Unit selection: -	Func. diagram: 7240
	Min	Max	Factory setting
	-	-	0
Description:	Sets the signal source for set input S and reset input R of instance RSR 2 of the RS flipflop.		
Index:	[0] = Set S [1] = Reset R		

r20325	BO: RSR 2 output Q / RSR 2 output Q		
	Access level: 3	Calculated: -	Data type: Unsigned32
	Can be changed: -	Scaling: -	Dyn. index: -
	Unit group: -	Unit selection: -	Func. diagram: 7240
	Min	Max	Factory setting
	-	-	-
Description:	Display parameter for output Q of instance RSR 2 of the RS flipflop		

r20326	BO: RSR 2 inverted output QN / RSR 2 inv outp QN		
	Access level: 3	Calculated: -	Data type: Unsigned32
	Can be changed: -	Scaling: -	Dyn. index: -
	Unit group: -	Unit selection: -	Func. diagram: 7240
	Min	Max	Factory setting
	-	-	-
Description:	Display parameter for inverted output QN of instance RSR 2 of the RS flipflop.		
p20327	RSR 2 runtime group / RSR 2 RTG		
	Access level: 3	Calculated: -	Data type: Integer16
	Can be changed: T	Scaling: -	Dyn. index: -
	Unit group: -	Unit selection: -	Func. diagram: 7240
	Min	Max	Factory setting
	1	9999	9999
Description:	Setting parameter for the runtime group in which instance RSR 2 of the RS flipflop is to be called.		
Value:	1: Runtime group 1 2: Runtime group 2 3: Runtime group 3 4: Runtime group 4 5: Runtime group 5 6: Runtime group 6 9999: Do not calculate		
p20328	RSR 2 run sequence / RSR 2 RunSeq		
	Access level: 3	Calculated: -	Data type: Unsigned16
	Can be changed: T	Scaling: -	Dyn. index: -
	Unit group: -	Unit selection: -	Func. diagram: 7240
	Min	Max	Factory setting
	0	7999	850
Description:	Setting parameter for the run sequence of instance RSR 2 within the runtime group set in p20327.		
Note:	The function blocks with a lower run sequence value are calculated before function blocks with a higher run sequence value.		
p20329[0...3]	BI: DFR 2 inputs / DFR 2 inputs		
	Access level: 3	Calculated: -	Data type: U32 / Binary
	Can be changed: T	Scaling: -	Dyn. index: -
	Unit group: -	Unit selection: -	Func. diagram: 7240
	Min	Max	Factory setting
	-	-	0
Description:	Sets the signal source for trigger input I, D input D, set input S, and reset input R of instance DFR 2 of the D flipflop.		
Index:	[0] = Trigger input I [1] = D input D [2] = Set S [3] = Reset R		
r20330	BO: DFR 2 output Q / DFR 2 output Q		
	Access level: 3	Calculated: -	Data type: Unsigned32
	Can be changed: -	Scaling: -	Dyn. index: -
	Unit group: -	Unit selection: -	Func. diagram: 7240
	Min	Max	Factory setting
	-	-	-
Description:	Display parameter for output Q of instance DFR 2 of the D flipflop.		

r20331	BO: DFR 2 inverted output QN / DFR 2 inv outp QN		
	Access level: 3	Calculated: -	Data type: Unsigned32
	Can be changed: -	Scaling: -	Dyn. index: -
	Unit group: -	Unit selection: -	Func. diagram: 7240
	Min	Max	Factory setting
	-	-	-
Description:	Display parameter for the inverted output QN of instance DFR 2 of the D flipflop.		
p20332	DFR 2 runtime group / DFR 2 RTG		
	Access level: 3	Calculated: -	Data type: Integer16
	Can be changed: T	Scaling: -	Dyn. index: -
	Unit group: -	Unit selection: -	Func. diagram: 7240
	Min	Max	Factory setting
	1	9999	9999
Description:	Setting parameter for the runtime group in which instance DFR 2 of the D flipflop is to be called.		
Value:	1: Runtime group 1 2: Runtime group 2 3: Runtime group 3 4: Runtime group 4 5: Runtime group 5 6: Runtime group 6 9999: Do not calculate		
p20333	DFR 2 run sequence / DFR 2 RunSeq		
	Access level: 3	Calculated: -	Data type: Unsigned16
	Can be changed: T	Scaling: -	Dyn. index: -
	Unit group: -	Unit selection: -	Func. diagram: 7240
	Min	Max	Factory setting
	0	32000	870
Description:	Setting parameter for the runtime group of instance DFR 2 within the runtime group set in p20332.		
Note:	The function blocks with a lower run sequence value are calculated before function blocks with a higher run sequence value.		
p20334	BI: PDE 2 input pulse I / PDE 2 inp_pulse I		
	Access level: 3	Calculated: -	Data type: U32 / Binary
	Can be changed: T	Scaling: -	Dyn. index: -
	Unit group: -	Unit selection: -	Func. diagram: 7232
	Min	Max	Factory setting
	-	-	0
Description:	Sets the signal source for the input pulse I of instance PDE 2 of the closing delay device.		
p20335	PDE 2 pulse delay time in ms / PDE 2 t_del ms		
	Access level: 3	Calculated: -	Data type: FloatingPoint32
	Can be changed: T	Scaling: -	Dyn. index: -
	Unit group: -	Unit selection: -	Func. diagram: 7232
	Min	Max	Factory setting
	0.00	5400000.00	0.00
Description:	Setting parameter for pulse delay time T in milliseconds of instance PDE 2 of the closing delay device.		

r20336	BO: PDE 2 output Q / PDE 2 output Q		
	Access level: 3	Calculated: -	Data type: Unsigned32
	Can be changed: -	Scaling: -	Dyn. index: -
	Unit group: -	Unit selection: -	Func. diagram: 7232
	Min	Max	Factory setting
	-	-	-
Description:	Display parameter for output pulse Q of instance PDE 2 of the closing delay device.		
p20337	PDE 2 runtime group / PDE 2 RTG		
	Access level: 3	Calculated: -	Data type: Integer16
	Can be changed: T	Scaling: -	Dyn. index: -
	Unit group: -	Unit selection: -	Func. diagram: 7232
	Min	Max	Factory setting
	5	9999	9999
Description:	Setting parameter for the runtime group in which instance PDE 2 of the closing delay device is to be called.		
Value:	5: Runtime group 5 6: Runtime group 6 9999: Do not calculate		
p20338	PDE 2 run sequence / PDE 2 RunSeq		
	Access level: 3	Calculated: -	Data type: Unsigned16
	Can be changed: T	Scaling: -	Dyn. index: -
	Unit group: -	Unit selection: -	Func. diagram: 7232
	Min	Max	Factory setting
	0	32000	890
Description:	Setting parameter for the run sequence of instance PDE 2 within the runtime group set in p20337.		
Note:	The function blocks with a lower run sequence value are calculated before function blocks with a higher run sequence value.		
p20339	BI: PDE 3 input pulse I / PDE 3 inp_pulse I		
	Access level: 3	Calculated: -	Data type: U32 / Binary
	Can be changed: T	Scaling: -	Dyn. index: -
	Unit group: -	Unit selection: -	Func. diagram: 7232
	Min	Max	Factory setting
	-	-	0
Description:	Sets the signal source for the input pulse I of instance PDE 3 of the closing delay device.		
p20340	PDE 3 pulse delay time in ms / PDE 3 t_del ms		
	Access level: 3	Calculated: -	Data type: FloatingPoint32
	Can be changed: T	Scaling: -	Dyn. index: -
	Unit group: -	Unit selection: -	Func. diagram: 7232
	Min	Max	Factory setting
	0.00	5400000.00	0.00
Description:	Setting parameter for pulse delay time T in milliseconds of instance PDE 3 of the closing delay device.		
r20341	BO: PDE 3 output Q / PDE 3 output Q		
	Access level: 3	Calculated: -	Data type: Unsigned32
	Can be changed: -	Scaling: -	Dyn. index: -
	Unit group: -	Unit selection: -	Func. diagram: 7232
	Min	Max	Factory setting
	-	-	-
Description:	Display parameter for output pulse Q of instance PDE 3 of the closing delay device.		

p20342	PDE 3 runtime group / PDE 3 RTG			
	Access level: 3	Calculated: -	Data type: Integer16	
	Can be changed: T	Scaling: -	Dyn. index: -	
	Unit group: -	Unit selection: -	Func. diagram: 7232	
	Min	Max	Factory setting	
	5	9999	9999	
Description:	Setting parameter for the runtime group in which instance PDE 3 of the closing delay device is to be called.			
Value:	5: Runtime group 5 6: Runtime group 6 9999: Do not calculate			
p20343	PDE 3 run sequence / PDE 3 RunSeq			
	Access level: 3	Calculated: -	Data type: Unsigned16	
	Can be changed: T	Scaling: -	Dyn. index: -	
	Unit group: -	Unit selection: -	Func. diagram: 7232	
	Min	Max	Factory setting	
	0	32000	900	
Description:	Setting parameter for the run sequence of instance PDE 3 within the runtime group set in p20342.			
Note:	The function blocks with a lower run sequence value are calculated before function blocks with a higher run sequence value.			
p20344	BI: PDF 2 input pulse I / PDF 2 inp_pulse I			
	Access level: 3	Calculated: -	Data type: U32 / Binary	
	Can be changed: T	Scaling: -	Dyn. index: -	
	Unit group: -	Unit selection: -	Func. diagram: 7233	
	Min	Max	Factory setting	
	-	-	0	
Description:	Sets the signal source for the input pulse I of instance PDF 2 of the breaking delay device.			
p20345	PDF 2 pulse extension time in ms / PDF 2 t_ext ms			
	Access level: 3	Calculated: -	Data type: FloatingPoint32	
	Can be changed: T	Scaling: -	Dyn. index: -	
	Unit group: -	Unit selection: -	Func. diagram: 7233	
	Min	Max	Factory setting	
	0.00	5400000.00	0.00	
Description:	Setting parameter for pulse extension time T in milliseconds of instance PDF 2 of the breaking delay device.			
r20346	BO: PDF 2 output Q / PDF 2 output Q			
	Access level: 3	Calculated: -	Data type: Unsigned32	
	Can be changed: -	Scaling: -	Dyn. index: -	
	Unit group: -	Unit selection: -	Func. diagram: 7233	
	Min	Max	Factory setting	
	-	-	-	
Description:	Display parameter for output pulse Q of instance PDF 2 of the breaking delay device.			
p20347	PDF 2 runtime group / PDF 2 RTG			
	Access level: 3	Calculated: -	Data type: Integer16	
	Can be changed: T	Scaling: -	Dyn. index: -	
	Unit group: -	Unit selection: -	Func. diagram: 7233	
	Min	Max	Factory setting	
	5	9999	9999	
Description:	Setting parameter for the runtime group in which the instance PDF 2 of the breaking delay device is to be called.			

Value: 5: Runtime group 5
6: Runtime group 6
9999: Do not calculate

p20348	PDF 2 run sequence / PDF 2 RunSeq		
	Access level: 3	Calculated: -	Data type: Unsigned16
	Can be changed: T	Scaling: -	Dyn. index: -
	Unit group: -	Unit selection: -	Func. diagram: 7233
	Min	Max	Factory setting
	0	32000	920
Description:	Setting parameter for the run sequence of instance PDE 2 within the runtime group set in p20347.		
Note:	The function blocks with a lower run sequence value are calculated before function blocks with a higher run sequence value.		

p20349	BI: PDF 3 input pulse I / PDF 3 inp_pulse I		
	Access level: 3	Calculated: -	Data type: U32 / Binary
	Can be changed: T	Scaling: -	Dyn. index: -
	Unit group: -	Unit selection: -	Func. diagram: 7233
	Min	Max	Factory setting
	-	-	0

Description: Sets the signal source for the input pulse I of instance PDF 3 of the breaking delay device.

p20350	PDF 3 pulse extension time in ms / PDF 3 t_ext ms		
	Access level: 3	Calculated: -	Data type: FloatingPoint32
	Can be changed: T	Scaling: -	Dyn. index: -
	Unit group: -	Unit selection: -	Func. diagram: 7233
	Min	Max	Factory setting
	0.00	5400000.00	0.00

Description: Setting parameter for pulse extension time T in milliseconds of instance PDF 3 of the breaking delay device.

r20351	BO: PDF 3 output Q / PDF 3 output Q		
	Access level: 3	Calculated: -	Data type: Unsigned32
	Can be changed: -	Scaling: -	Dyn. index: -
	Unit group: -	Unit selection: -	Func. diagram: 7233
	Min	Max	Factory setting
	-	-	-

Description: Display parameter for output pulse Q of instance PDF 3 of the breaking delay device.

p20352	PDF 3 runtime group / PDF 3 RTG		
	Access level: 3	Calculated: -	Data type: Integer16
	Can be changed: T	Scaling: -	Dyn. index: -
	Unit group: -	Unit selection: -	Func. diagram: 7233
	Min	Max	Factory setting
	5	9999	9999

Description: Setting parameter for the runtime group in which the instance PDF 3 of the breaking delay device is to be called.

Value: 5: Runtime group 5
6: Runtime group 6
9999: Do not calculate

2 Parameters

2.2 List of parameters

p20353	PDF 3 run sequence / PDF 3 RunSeq		
	Access level: 3	Calculated: -	Data type: Unsigned16
	Can be changed: T	Scaling: -	Dyn. index: -
	Unit group: -	Unit selection: -	Func. diagram: 7233
	Min	Max	Factory setting
	0	32000	930
Description:	Setting parameter for the run sequence of instance PDE 3 within the runtime group set in p20352.		
Note:	The function blocks with a lower run sequence value are calculated before function blocks with a higher run sequence value.		

p20354	BI: MFP 2 input pulse I / MFP 2 inp_pulse I		
	Access level: 3	Calculated: -	Data type: U32 / Binary
	Can be changed: T	Scaling: -	Dyn. index: -
	Unit group: -	Unit selection: -	Func. diagram: 7230
	Min	Max	Factory setting
	-	-	0
Description:	Sets the signal source for the input pulse I of instance MFP 2 of the pulse generator.		

p20355	MFP 2 pulse duration in ms / MFP 2 pulse_dur ms		
	Access level: 3	Calculated: -	Data type: FloatingPoint32
	Can be changed: T	Scaling: -	Dyn. index: -
	Unit group: -	Unit selection: -	Func. diagram: 7230
	Min	Max	Factory setting
	0.00	5400000.00	0.00
Description:	Setting parameter for pulse duration T in milliseconds of instance MFP 2 of the pulse generator.		

r20356	BO: MFP 2 output Q / MFP 2 output Q		
	Access level: 3	Calculated: -	Data type: Unsigned32
	Can be changed: -	Scaling: -	Dyn. index: -
	Unit group: -	Unit selection: -	Func. diagram: 7230
	Min	Max	Factory setting
	-	-	-
Description:	Display parameter for output pulse Q of instance MFP 2 of the pulse generator.		

p20357	MFP 2 runtime group / MFP 2 RTG		
	Access level: 3	Calculated: -	Data type: Integer16
	Can be changed: T	Scaling: -	Dyn. index: -
	Unit group: -	Unit selection: -	Func. diagram: 7230
	Min	Max	Factory setting
	5	9999	9999
Description:	Setting parameter for the runtime group in which the instance MFP 2 of the pulse generator is to be called.		
Value:	5: Runtime group 5 6: Runtime group 6 9999: Do not calculate		

p20358	MFP 2 run sequence / MFP 2 RunSeq		
	Access level: 3	Calculated: -	Data type: Unsigned16
	Can be changed: T	Scaling: -	Dyn. index: -
	Unit group: -	Unit selection: -	Func. diagram: 7230
	Min	Max	Factory setting
	0	32000	950
Description:	Setting parameter for the run sequence of instance MFP 2 within the runtime group set in p20357.		

Note: The function blocks with a lower run sequence value are calculated before function blocks with a higher run sequence value.

p20359	BI: MFP 3 input pulse I / MFP 3 inp_pulse I		
	Access level: 3	Calculated: -	Data type: U32 / Binary
	Can be changed: T	Scaling: -	Dyn. index: -
	Unit group: -	Unit selection: -	Func. diagram: 7230
	Min	Max	Factory setting
	-	-	0

Description: Sets the signal source for the input pulse I of instance MFP 3 of the pulse generator.

p20360	MFP 3 pulse duration in ms / MFP 3 pulse_dur ms		
	Access level: 3	Calculated: -	Data type: FloatingPoint32
	Can be changed: T	Scaling: -	Dyn. index: -
	Unit group: -	Unit selection: -	Func. diagram: 7230
	Min	Max	Factory setting
	0.00	5400000.00	0.00

Description: Setting parameter for pulse duration T in milliseconds of instance MFP 3 of the pulse generator.

r20361	BO: MFP 3 output Q / MFP 3 output Q		
	Access level: 3	Calculated: -	Data type: Unsigned32
	Can be changed: -	Scaling: -	Dyn. index: -
	Unit group: -	Unit selection: -	Func. diagram: 7230
	Min	Max	Factory setting
	-	-	-

Description: Display parameter for output pulse Q of instance MFP 3 of the pulse generator.

p20362	MFP 3 runtime group / MFP 3 RTG		
	Access level: 3	Calculated: -	Data type: Integer16
	Can be changed: T	Scaling: -	Dyn. index: -
	Unit group: -	Unit selection: -	Func. diagram: 7230
	Min	Max	Factory setting
	5	9999	9999

Description: Setting parameter for the runtime group in which the instance MFP 3 of the pulse generator is to be called.

Value:
 5: Runtime group 5
 6: Runtime group 6
 9999: Do not calculate

p20363	MFP 3 run sequence / MFP 3 RunSeq		
	Access level: 3	Calculated: -	Data type: Unsigned16
	Can be changed: T	Scaling: -	Dyn. index: -
	Unit group: -	Unit selection: -	Func. diagram: 7230
	Min	Max	Factory setting
	0	32000	960

Description: Setting parameter for the run sequence of instance MFP 3 within the runtime group set in p20362.

Note: The function blocks with a lower run sequence value are calculated before function blocks with a higher run sequence value.

p20372	CI: PLI 0 input X / PLI 0 input X		
	Access level: 3	Calculated: -	Data type: U32 / FloatingPoint32
	Can be changed: T	Scaling: PERCENT	Dyn. index: -
	Unit group: -	Unit selection: -	Func. diagram: 7226
	Min	Max	Factory setting
	-	-	0
Description:	Sets the signal source for input X of the polyline (20 breakpoints) of instance PLI 0.		

r20373	CO: PLI 0 output Y / PLI 0 output Y		
	Access level: 3	Calculated: -	Data type: FloatingPoint32
	Can be changed: -	Scaling: PERCENT	Dyn. index: -
	Unit group: -	Unit selection: -	Func. diagram: 7226
	Min	Max	Factory setting
	-	-	-
Description:	Display parameter for the output quantity Y of the polyline (20 breakpoints) of instance PLI 0		

p20374[0...19]	PLI 0 X-coordinate, A breakpoint / PLI 0 X-coordinate		
	Access level: 3	Calculated: -	Data type: FloatingPoint32
	Can be changed: T	Scaling: PERCENT	Dyn. index: -
	Unit group: -	Unit selection: -	Func. diagram: 7226
	Min	Max	Factory setting
	-340.28235E36	340.28235E36	0.0000

Description: Sets the x-coordinates for the breakpoints (A0 ... A19) of the polyline (20 breakpoints) of instance PLI 0.

Index:

- [0] = Breakpoint 0
- [1] = Breakpoint 1
- [2] = Breakpoint 2
- [3] = Breakpoint 3
- [4] = Breakpoint 4
- [5] = Breakpoint 5
- [6] = Breakpoint 6
- [7] = Breakpoint 7
- [8] = Breakpoint 8
- [9] = Breakpoint 9
- [10] = Breakpoint 10
- [11] = Breakpoint 11
- [12] = Breakpoint 12
- [13] = Breakpoint 13
- [14] = Breakpoint 14
- [15] = Breakpoint 15
- [16] = Breakpoint 16
- [17] = Breakpoint 17
- [18] = Breakpoint 18
- [19] = Breakpoint 19

p20375[0...19]	PLI 0 Y-coordinate, B breakpoint / PLI 0 Y-coordinate		
	Access level: 3	Calculated: -	Data type: FloatingPoint32
	Can be changed: T	Scaling: PERCENT	Dyn. index: -
	Unit group: -	Unit selection: -	Func. diagram: 7226
	Min	Max	Factory setting
	-340.28235E36	340.28235E36	0.0000

Description: Sets the y-coordinates for the breakpoints (B0 ... B19) of the polyline (20 breakpoints) of instance PLI 0.

Index:	[0] = Breakpoint 0
	[1] = Breakpoint 1
	[2] = Breakpoint 2
	[3] = Breakpoint 3
	[4] = Breakpoint 4
	[5] = Breakpoint 5
	[6] = Breakpoint 6
	[7] = Breakpoint 7
	[8] = Breakpoint 8
	[9] = Breakpoint 9
	[10] = Breakpoint 10
	[11] = Breakpoint 11
	[12] = Breakpoint 12
	[13] = Breakpoint 13
	[14] = Breakpoint 14
	[15] = Breakpoint 15
	[16] = Breakpoint 16
	[17] = Breakpoint 17
	[18] = Breakpoint 18
	[19] = Breakpoint 19

p20376	PLI 0 runtime group / PLI 0 RTG		
	Access level: 3	Calculated: -	Data type: Integer16
	Can be changed: T	Scaling: -	Dyn. index: -
	Unit group: -	Unit selection: -	Func. diagram: 7226
	Min	Max	Factory setting
	5	9999	9999

Description: Setting parameter for the runtime group in which instance PLI 0 of the polyline is to be called

Value:
 5: Runtime group 5
 6: Runtime group 6
 9999: Do not calculate

p20377	PLI 0 run sequence / PLI 0 RunSeq		
	Access level: 3	Calculated: -	Data type: Unsigned16
	Can be changed: T	Scaling: -	Dyn. index: -
	Unit group: -	Unit selection: -	Func. diagram: 7226
	Min	Max	Factory setting
	0	32000	980

Description: Setting parameter for the run sequence of instance PLI 0 within the runtime group set in p20376.

Note: The function blocks with a lower run sequence value are calculated before function blocks with a higher run sequence value.

p20378	CI: PLI 1 input X / PLI 1 input X		
	Access level: 3	Calculated: -	Data type: U32 / FloatingPoint32
	Can be changed: T	Scaling: PERCENT	Dyn. index: -
	Unit group: -	Unit selection: -	Func. diagram: 7226
	Min	Max	Factory setting
	-	-	0

Description: Sets the signal source for input X of the polyline (20 breakpoints) of instance PLI 1.

r20379	CO: PLI 1 output Y / PLI 1 output Y		
	Access level: 3	Calculated: -	Data type: FloatingPoint32
	Can be changed: -	Scaling: PERCENT	Dyn. index: -
	Unit group: -	Unit selection: -	Func. diagram: 7226
	Min	Max	Factory setting
	-	-	-

Description: Display parameter for the output quantity Y of the polyline (20 breakpoints) of instance PLI 1

p20380[0...19]	PLI 1 X-coordinate, A breakpoint / PLI 1 X-coordinate		
	Access level: 3	Calculated: -	Data type: FloatingPoint32
	Can be changed: T	Scaling: PERCENT	Dyn. index: -
	Unit group: -	Unit selection: -	Func. diagram: 7226
	Min	Max	Factory setting
	-340.28235E36	340.28235E36	0.0000
Description:	Sets the x-coordinates for the breakpoints (A0 ... A19) of the polyline (20 breakpoints) of instance PLI 1.		
Index:	[0] = Breakpoint 0 [1] = Breakpoint 1 [2] = Breakpoint 2 [3] = Breakpoint 3 [4] = Breakpoint 4 [5] = Breakpoint 5 [6] = Breakpoint 6 [7] = Breakpoint 7 [8] = Breakpoint 8 [9] = Breakpoint 9 [10] = Breakpoint 10 [11] = Breakpoint 11 [12] = Breakpoint 12 [13] = Breakpoint 13 [14] = Breakpoint 14 [15] = Breakpoint 15 [16] = Breakpoint 16 [17] = Breakpoint 17 [18] = Breakpoint 18 [19] = Breakpoint 19		

p20381[0...19]	PLI 1 Y-coordinate, B breakpoint / PLI 1 Y-coordinate		
	Access level: 3	Calculated: -	Data type: FloatingPoint32
	Can be changed: T	Scaling: PERCENT	Dyn. index: -
	Unit group: -	Unit selection: -	Func. diagram: 7226
	Min	Max	Factory setting
	-340.28235E36	340.28235E36	0.0000
Description:	Sets the y-coordinates for the breakpoints (B0 ... B19) of the polyline (20 breakpoints) of instance PLI 1.		
Index:	[0] = Breakpoint 0 [1] = Breakpoint 1 [2] = Breakpoint 2 [3] = Breakpoint 3 [4] = Breakpoint 4 [5] = Breakpoint 5 [6] = Breakpoint 6 [7] = Breakpoint 7 [8] = Breakpoint 8 [9] = Breakpoint 9 [10] = Breakpoint 10 [11] = Breakpoint 11 [12] = Breakpoint 12 [13] = Breakpoint 13 [14] = Breakpoint 14 [15] = Breakpoint 15 [16] = Breakpoint 16 [17] = Breakpoint 17 [18] = Breakpoint 18 [19] = Breakpoint 19		

p20382	PLI 1 runtime group / PLI 1 RTG		
	Access level: 3	Calculated: -	Data type: Integer16
	Can be changed: T	Scaling: -	Dyn. index: -
	Unit group: -	Unit selection: -	Func. diagram: 7226
	Min	Max	Factory setting
	5	9999	9999
Description:	Setting parameter for the runtime group in which instance PLI 1 of the polyline is to be called		
Value:	5: Runtime group 5 6: Runtime group 6 9999: Do not calculate		
p20383	PLI 1 run sequence / PLI 1 RunSeq		
	Access level: 3	Calculated: -	Data type: Unsigned16
	Can be changed: T	Scaling: -	Dyn. index: -
	Unit group: -	Unit selection: -	Func. diagram: 7226
	Min	Max	Factory setting
	0	32000	990
Description:	Setting parameter for the run sequence of instance PLI 1 within the runtime group set in p20382.		
Note:	The function blocks with a lower run sequence value are calculated before function blocks with a higher run sequence value.		
p60000	PROFIdrive reference speed reference frequency / PD n_ref f_ref		
G115D PN	Access level: 2	Calculated: p0340 = 1	Data type: FloatingPoint32
	Can be changed: T	Scaling: -	Dyn. index: -
	Unit group: -	Unit selection: -	Func. diagram: -
	Min	Max	Factory setting
	6.00 [rpm]	210000.00 [rpm]	1500.00 [rpm]
Description:	Sets the reference quantity for speed and frequency. All speeds or frequencies specified as relative value are referred to this reference quantity. The reference quantity corresponds to 100% or 4000 hex (word) or 4000 0000 hex (double word). The following applies: reference frequency (in Hz) = reference speed (in ((rpm) / 60) x pole pair number)		
Dependency:	Refer to: p2000		
Notice:	When the reference speed / reference frequency is changed, short-term communication interruptions may occur.		
Note:	Parameter p60000 is an image of parameter p2000 in conformance with PROFIdrive. A change always effects both parameters. If a BICO interconnection is established between different physical quantities, then the particular reference quantities are used as internal conversion factor. Example: The setpoint from PROFIBUS (r2050[1]) is connected to a speed setpoint (e.g. p1070[0]). The actual input value is cyclically converted into a percentage value via the pre-specified scaling 4000 hex. This percentage value is converted to the absolute speed setpoint using the reference speed (p60000). The setpoint from PROFIBUS (r2060[1]) is connected to a speed setpoint (e.g. p1155[0]). The actual input value is cyclically converted into a percentage value via the pre-specified scaling 4000 0000 hex. This percentage value is converted to the absolute speed setpoint using the reference speed (p60000).		
p60022	PROFIsafe telegram selection / Ps telegram_sel		
G115D PN	Access level: 3	Calculated: -	Data type: Unsigned16
	Can be changed: T	Scaling: -	Dyn. index: -
	Unit group: -	Unit selection: -	Func. diagram: -
	Min	Max	Factory setting
	0	998	998
Description:	Sets the telegram number for PROFIsafe.		

2 Parameters

2.2 List of parameters

Value:
0: No PROFIsafe telegram selected
30: PROFIsafe standard telegram 30, PZD-1/1
900: PROFIsafe SIEMENS telegram 900, PZD-2/2
998: Compatibility mode (as for firmware version < 4.6)

r61000[0...239]	PROFINET Name of Station / PN Name of Station		
G115D PN	Access level: 3	Calculated: -	Data type: Unsigned8
	Can be changed: -	Scaling: -	Dyn. index: -
	Unit group: -	Unit selection: -	Func. diagram: 2410
	Min	Max	Factory setting
	-	-	-
Description:	Displays PROFINET Name of Station.		
Notice:	An ASCII table (excerpt) can be found, for example, in the appendix to the List Manual.		

r61001[0...3]	PROFINET IP of Station / PN IP of Station		
G115D PN	Access level: 3	Calculated: -	Data type: Unsigned8
	Can be changed: -	Scaling: -	Dyn. index: -
	Unit group: -	Unit selection: -	Func. diagram: 2410
	Min	Max	Factory setting
	-	-	-
Description:	Displays PROFINET IP of Station.		

2.3 Parameters for data sets

2.3.1 Command Data Sets (CDS)

Product: G115D, Version: 4715218, Language: eng, Type: CDS

p0641[0...n]	Cl: Current limit, variable / Curr lim var
p0820[0...n]	Bl: Drive Data Set selection DDS bit 0 / DDS select., bit 0
p0821[0...n]	Bl: Drive Data Set selection DDS bit 1 / DDS select., bit 1
p0840[0...n]	Bl: ON / OFF (OFF1) / ON / OFF (OFF1)
p0844[0...n]	Bl: No coast-down / coast-down (OFF2) signal source 1 / OFF2 S_s 1
p0845[0...n]	Bl: No coast-down / coast-down (OFF2) signal source 2 / OFF2 S_s 2
p0848[0...n]	Bl: No Quick Stop / Quick Stop (OFF3) signal source 1 / OFF3 S_s 1
p0849[0...n]	Bl: No Quick Stop / Quick Stop (OFF3) signal source 2 / OFF3 S_s 2
p0852[0...n]	Bl: Enable operation/inhibit operation / Enable operation
p0854[0...n]	Bl: Control by PLC/no control by PLC / Master ctrl by PLC
p0855[0...n]	Bl: Unconditionally release holding brake / Uncond open brake
p0856[0...n]	Bl: Enable speed controller / n_ctrl enable
p0858[0...n]	Bl: Unconditionally close holding brake / Uncond close brake
p1000[0...n]	Speed setpoint selection / n_set sel
p1020[0...n]	Bl: Fixed speed setpoint selection Bit 0 / n_set_fixed Bit 0
p1021[0...n]	Bl: Fixed speed setpoint selection Bit 1 / n_set_fixed Bit 1
p1022[0...n]	Bl: Fixed speed setpoint selection Bit 2 / n_set_fixed Bit 2
p1023[0...n]	Bl: Fixed speed setpoint selection Bit 3 / n_set_fixed Bit 3
p1035[0...n]	Bl: Motorized potentiometer setpoint raise / Mop raise
p1036[0...n]	Bl: Motorized potentiometer lower setpoint / Mop lower
p1039[0...n]	Bl: Motorized potentiometer inversion / MotP inv
p1041[0...n]	Bl: Motorized potentiometer manual/automatic / Mop manual/auto
p1042[0...n]	Cl: Motorized potentiometer automatic setpoint / Mop auto setpoint
p1043[0...n]	Bl: Motorized potentiometer accept setting value / MotP acc set val
p1044[0...n]	Cl: Motorized potentiometer setting value / Mop set val
p1051[0...n]	Cl: Speed limit RFG positive direction of rotation / n_limit RFG pos
p1052[0...n]	Cl: Speed limit RFG negative direction of rotation / n_limit RFG neg
p1055[0...n]	Bl: Jog bit 0 / Jog bit 0
p1056[0...n]	Bl: Jog bit 1 / Jog bit 1
p1070[0...n]	Cl: Main setpoint / Main setpoint
p1071[0...n]	Cl: Main setpoint scaling / Main setp scal
p1075[0...n]	Cl: Supplementary setp / Suppl setp
p1076[0...n]	Cl: Supplementary setpoint scaling / Suppl setp scal
p1085[0...n]	Cl: Speed limit in positive direction of rotation / n_limit pos
p1088[0...n]	Cl: Speed limit in negative direction of rotation / n_limit neg
p1098[0...n]	Cl: Skip speed scaling / n_skip scal
p1106[0...n]	Cl: Minimum speed signal source / n_min s_s
p1108[0...n]	Bl: Total setpoint selection / Total setp sel
p1109[0...n]	Cl: Total setpoint / Total setp
p1110[0...n]	Bl: Inhibit negative direction / Inhib neg dir
p1111[0...n]	Bl: Inhibit positive direction / Inhib pos dir
p1113[0...n]	Bl: Setpoint inversion / Setp inv
p1122[0...n]	Bl: Bypass ramp-function generator / Bypass RFG
p1138[0...n]	Cl: Ramp-function generator ramp-up time scaling / RFG t_RU scal
p1139[0...n]	Cl: Ramp-function generator ramp-down time scaling / RFG t_RD scal
p1140[0...n]	Bl: Enable ramp-function generator/inhibit ramp-function generator / Enable RFG
p1141[0...n]	Bl: Continue ramp-function generator/freeze ramp-function generator / Continue RFG
p1142[0...n]	Bl: Enable setpoint/inhibit setpoint / Setpoint enable

p1143[0...n]	BI: Ramp-function generator, accept setting value / RFG accept set v
p1144[0...n]	CI: Ramp-function generator setting value / RFG setting value
p1155[0...n]	CI: Speed controller speed setpoint 1 / n_ctrl n_set 1
p1160[0...n]	CI: Speed controller speed setpoint 2 / n_ctrl n_set 2
p1201[0...n]	BI: Flying restart enable signal source / Fly_res enab s_s
p1230[0...n]	BI: DC braking activation / DC brake act
p1330[0...n]	CI: U/f control independent voltage setpoint / Uf U_set independ.
p1352[0...n]	CI: Motor holding brake starting frequency signal source / Brake f_start
p1455[0...n]	CI: Speed controller P gain adaptation signal / n_ctr adapt_sig Kp
p1466[0...n]	CI: Speed controller P-gain scaling / n_ctrl Kp scal
p1475[0...n]	CI: Speed controller torque setting value for motor holding brake / n_ctrl M_sv MHB
p1476[0...n]	BI: Speed controller hold integrator / n_ctrl integ stop
p1477[0...n]	BI: Speed controller set integrator value / n_ctrl integ set
p1478[0...n]	CI: Speed controller integrator setting value / n_ctr integ_setVal
p1479[0...n]	CI: Speed controller integrator setting value scaling / n_ctrl I_val scal
p1486[0...n]	CI: Droop compensation torque / Droop M_comp
p1492[0...n]	BI: Droop feedback enable / Droop enable
p1500[0...n]	Torque setpoint selection / M_set sel
p1501[0...n]	BI: Change over between closed-loop speed/torque control / Changeov n/M_ctrl
p1502[0...n]	BI: Freeze moment of inertia estimator / J_estim freeze
p1503[0...n]	CI: Torque setpoint / M_set
p1511[0...n]	CI: Supplementary torque 1 / M_suppl 1
p1512[0...n]	CI: Supplementary torque 1 scaling / M_suppl 1 scal
p1513[0...n]	CI: Supplementary torque 2 / M_suppl 2
p1522[0...n]	CI: Torque limit upper / M_max upper
p1523[0...n]	CI: Torque limit lower / M_max lower
p1528[0...n]	CI: Torque limit upper scaling / M_max upper scal
p1529[0...n]	CI: Torque limit lower scaling / M_max lower scal
p1552[0...n]	CI: Torque limit upper scaling without offset / M_max up w/o offs
p1554[0...n]	CI: Torque limit lower scaling without offset / M_max low w/o offs
p2103[0...n]	BI: 1st acknowledge faults / 1st acknowledge
p2104[0...n]	BI: 2nd acknowledge faults / 2nd acknowledge
p2105[0...n]	BI: 3rd acknowledge faults / 3rd acknowledge
p2106[0...n]	BI: External fault 1 / External fault 1
p2107[0...n]	BI: External fault 2 / External fault 2
p2108[0...n]	BI: External fault 3 / External fault 3
p2112[0...n]	BI: External alarm 1 / External alarm 1
p2116[0...n]	BI: External alarm 2 / External alarm 2
p2117[0...n]	BI: External alarm 3 / External alarm 3
p2144[0...n]	BI: Motor stall monitoring enable (negated) / Mot stall enab neg
p2148[0...n]	BI: RFG active / RFG active
p2151[0...n]	CI: Speed setpoint for messages/signals / n_set for msg
p2200[0...n]	BI: Technology controller enable / Tec_ctrl enable
p2220[0...n]	BI: Technology controller fixed value selection bit 0 / Tec_ctrl sel bit 0
p2221[0...n]	BI: Technology controller fixed value selection bit 1 / Tec_ctrl sel bit 1
p2222[0...n]	BI: Technology controller fixed value selection bit 2 / Tec_ctrl sel bit 2
p2223[0...n]	BI: Technology controller fixed value selection bit 3 / Tec_ctrl sel bit 3
p2235[0...n]	BI: Technology controller motorized potentiometer raise setpoint / Tec_ctrl mop raise
p2236[0...n]	BI: Technology controller motorized potentiometer lower setpoint / Tec_ctrl mop lower
p2253[0...n]	CI: Technology controller setpoint 1 / Tec_ctrl setp 1
p2254[0...n]	CI: Technology controller setpoint 2 / Tec_ctrl setp 2
p2264[0...n]	CI: Technology controller actual value / Tec_ctrl act val
p2286[0...n]	BI: Hold technology controller integrator / Tec_ctr integ hold
p2289[0...n]	CI: Technology controller precontrol signal / Tec_ctr prectr_sig
p2290[0...n]	BI: Technology controller limiting enable / Tec_ctrl lim enab

p2296[0...n]	Cl: Technology controller output scaling / Tec_ctrl outp scal
p2297[0...n]	Cl: Technology controller maximum limit signal source / Tec_ctrMaxLim s_s
p2298[0...n]	Cl: Technology controller minimum limit signal source / Tec_ctrl min_l s_s
p2299[0...n]	Cl: Technology controller limit offset / Tech_ctrl lim offs
p3111[0...n]	Bl: External fault 3 enable / Ext fault 3 enab
p3112[0...n]	Bl: External fault 3 enable negated / Ext flt 3 enab neg
p3230[0...n]	Cl: Load monitoring speed actual value / Load monit n_act
p3232[0...n]	Bl: Load monitoring failure detection / Load_moni fail_det
p3330[0...n]	Bl: 2/3 wire control command 1 / 2/3 wire cmd 1
p3331[0...n]	Bl: 2/3 wire control command 2 / 2/3 wire cmd 2
p3332[0...n]	Bl: 2/3 wire control command 3 / 2/3 wire cmd 3

2.3.2 Drive Data Sets (DDS)

Product: G115D, Version: 4715218, Language: eng, Type: DDS

p0133[0...n]	Motor configuration / Motor config
p0300[0...n]	Motor type selection / Mot type sel
p0301[0...n]	Motor code number selection / Mot code No. sel
p0304[0...n]	Rated motor voltage / Mot U_rated
p0305[0...n]	Rated motor current / Mot I_rated
p0307[0...n]	Rated motor power / Mot P_rated
p0308[0...n]	Rated motor power factor / Mot cos phi rated
p0309[0...n]	Rated motor efficiency / Mot eta_rated
p0310[0...n]	Rated motor frequency / Mot f_rated
p0311[0...n]	Rated motor speed / Mot n_rated
r0313[0...n]	Motor pole pair number, actual (or calculated) / Mot PolePairNo act
p0314[0...n]	Motor pole pair number / Mot pole pair No.
p0316[0...n]	Motor torque constant / Mot kT
p0318[0...n]	Motor stall current / Mot I_standstill
p0320[0...n]	Motor rated magnetizing current/short-circuit current / Mot I_mag_rated
p0322[0...n]	Maximum motor speed / Mot n_max
p0323[0...n]	Maximum motor current / Mot I_max
p0325[0...n]	Motor pole position identification current 1st phase / Mot PolID I 1st Ph
p0326[0...n]	Motor stall torque correction factor / Mot M_stall_corr
p0327[0...n]	Optimum motor load angle / Mot phi_load opt
p0328[0...n]	Motor reluctance torque constant / Mot kT_reluctance
p0329[0...n]	Motor pole position identification current / Mot PolID current
r0330[0...n]	Rated motor slip / Mot slip_rated
r0331[0...n]	Actual motor magnetizing current/short-circuit current / Mot I_mag_rtd act
r0332[0...n]	Rated motor power factor / Mot cos phi rated
r0333[0...n]	Rated motor torque / Mot M_rated
r0334[0...n]	Actual motor-torque constant / Mot kT act
p0335[0...n]	Motor cooling type / Mot cool type
r0337[0...n]	Rated motor EMF / Mot EMF_rated
p0340[0...n]	Automatic calculation motor/control parameters / Calc auto par
p0341[0...n]	Motor moment of inertia / Mot M_mom of inert
p0342[0...n]	Ratio between the total and motor moment of inertia / Mot MomInert Ratio
r0343[0...n]	Rated motor current identified / Mot I_rated ident
p0344[0...n]	Motor weight (for the thermal motor model) / Mot weight th mod
r0345[0...n]	Nominal motor starting time / Mot t_start_rated
p0346[0...n]	Motor excitation build-up time / Mot t_excitation
p0347[0...n]	Motor de-excitation time / Mot t_de-excitat
p0350[0...n]	Motor stator resistance cold / Mot R_stator cold
p0352[0...n]	Cable resistance / R_cable

p0354[0...n]	Motor rotor resistance cold / Mot R_r cold
p0356[0...n]	Motor stator leakage inductance / Mot L_stator leak.
p0357[0...n]	Motor stator inductance d axis / Mot L_stator d
p0358[0...n]	Motor rotor leakage inductance / Mot L_rot leak
p0360[0...n]	Motor magnetizing inductance / Mot Lh
p0362[0...n]	Motor saturation characteristic flux 1 / Mot saturat.flux 1
p0363[0...n]	Motor saturation characteristic flux 2 / Mot saturat.flux 2
p0364[0...n]	Motor saturation characteristic flux 3 / Mot saturat.flux 3
p0365[0...n]	Motor saturation characteristic flux 4 / Mot saturat.flux 4
p0366[0...n]	Motor saturation characteristic I_mag 1 / Mot sat. I_mag 1
p0367[0...n]	Motor saturation characteristic I_mag 2 / Mot sat. I_mag 2
p0368[0...n]	Motor saturation characteristic I_mag 3 / Mot sat. I_mag 3
p0369[0...n]	Motor saturation characteristic I_mag 4 / Mot sat. I_mag 4
r0370[0...n]	Motor stator resistance cold / Mot R_stator cold
r0372[0...n]	Cable resistance / Mot R_cable
r0373[0...n]	Motor rated stator resistance / Mot R_stator rated
r0374[0...n]	Motor rotor resistance cold / Mot R_r cold
r0376[0...n]	Rated motor rotor resistance / Mot rated R_rotor
r0377[0...n]	Motor leakage inductance total / Mot L_leak total
r0378[0...n]	Motor stator inductance d axis / Mot L_stator d
r0382[0...n]	Motor magnetizing inductance transformed / Mot L_magn transf
r0384[0...n]	Motor rotor time constant / damping time constant d axis / Mot T_rotor/T_Dd
r0386[0...n]	Motor stator leakage time constant / Mot T_stator leak
r0394[0...n]	Rated motor power / Mot P_rated
r0395[0...n]	Actual stator resistance / R_stator act
r0396[0...n]	Actual rotor resistance / R_rotor act
p0541[0...n]	Load gearbox code number / Load grbx CodeNo
p0542[0...n]	Load gearbox maximum speed / Load grbx n_max
p0543[0...n]	Load gearbox maximum torque / Load grbx M_max
p0544[0...n]	Load gearbox overall ratio (absolute value) numerator / Load grbx ratio N
p0545[0...n]	Load gearbox overall ratio (absolute value) denominator / Load grbx ratio D
p0546[0...n]	Load gearbox output direction of rotation inversion / Load grbx outp inv
p0550[0...n]	Brake type / Brake type
p0551[0...n]	Brake code number / Brake code no.
p0552[0...n]	Maximum brake speed / Brake n_max
p0553[0...n]	Brake holding torque / Brake M_hold
p0554[0...n]	Brake moment of inertia / Brake J
p0601[0...n]	Motor temperature sensor type / Mot_temp_sens type
p0604[0...n]	Mot_temp_mod 2/sensor alarm threshold / Mod 2/sens A_thr
p0605[0...n]	Mot_temp_mod 1/2/sensor threshold and temperature value / Mod1/2/sens T_thr
p0606[0...n]	Mot_temp_mod 2/sensor timer / Mod 2/sens timer
p0607[0...n]	Temperature sensor fault timer / Sensor fault time
p0610[0...n]	Motor overtemperature response / Mot temp response
p0611[0...n]	I2t motor model thermal time constant / I2t mot_mod T
p0612[0...n]	Mot_temp_mod activation / Mot_temp_mod act
p0613[0...n]	Mot_temp_mod 1/3 ambient temperature / Mod 1/3 amb_temp
p0614[0...n]	Thermal resistance adaptation reduction factor / Therm R_adapt red
p0615[0...n]	Mot_temp_mod 1 (I2t) fault threshold / I2t F thresh
p0620[0...n]	Thermal adaptation, stator and rotor resistance / Mot therm_adapt R
p0621[0...n]	Identification stator resistance after restart / Rst_ident Restart
p0622[0...n]	Motor excitation time for Rs_ident after switching on again / t_excit Rs_id
p0625[0...n]	Motor ambient temperature during commissioning / Mot T_ambient
p0626[0...n]	Motor overtemperature, stator core / Mot T_over core
p0627[0...n]	Motor overtemperature, stator winding / Mot T_over stator
p0628[0...n]	Motor overtemperature rotor / Mot T_over rotor

r0630[0...n]	Mot_temp_mod ambient temperature / Mod T_ambient
r0631[0...n]	Mot_temp_mod stator iron temperature / Mod T_stator
r0632[0...n]	Mot_temp_mod stator winding temperature / Mod T_winding
r0633[0...n]	Mot_temp_mod rotor temperature / Mod rotor temp
p0640[0...n]	Current limit / Current limit
p0650[0...n]	Actual motor operating hours / Oper hours motor
p0651[0...n]	Motor operating hours maintenance interval / Mot t_op maint
p0826[0...n]	Motor changeover motor number / Mot_chng mot No.
p1001[0...n]	CO: Fixed speed setpoint 1 / n_set_fixed 1
p1002[0...n]	CO: Fixed speed setpoint 2 / n_set_fixed 2
p1003[0...n]	CO: Fixed speed setpoint 3 / n_set_fixed 3
p1004[0...n]	CO: Fixed speed setpoint 4 / n_set_fixed 4
p1005[0...n]	CO: Fixed speed setpoint 5 / n_set_fixed 5
p1006[0...n]	CO: Fixed speed setpoint 6 / n_set_fixed 6
p1007[0...n]	CO: Fixed speed setpoint 7 / n_set_fixed 7
p1008[0...n]	CO: Fixed speed setpoint 8 / n_set_fixed 8
p1009[0...n]	CO: Fixed speed setpoint 9 / n_set_fixed 9
p1010[0...n]	CO: Fixed speed setpoint 10 / n_set_fixed 10
p1011[0...n]	CO: Fixed speed setpoint 11 / n_set_fixed 11
p1012[0...n]	CO: Fixed speed setpoint 12 / n_set_fixed 12
p1013[0...n]	CO: Fixed speed setpoint 13 / n_set_fixed 13
p1014[0...n]	CO: Fixed speed setpoint 14 / n_set_fixed 14
p1015[0...n]	CO: Fixed speed setpoint 15 / n_set_fixed 15
p1030[0...n]	Motorized potentiometer configuration / Mop configuration
p1037[0...n]	Motorized potentiometer maximum speed / MotP n_max
p1038[0...n]	Motorized potentiometer minimum speed / MotP n_min
p1040[0...n]	Motorized potentiometer starting value / Mop start value
p1047[0...n]	Motorized potentiometer ramp-up time / Mop ramp-up time
p1048[0...n]	Motorized potentiometer ramp-down time / Mop ramp-down time
p1058[0...n]	Jog 1 speed setpoint / Jog 1 n_set
p1059[0...n]	Jog 2 speed setpoint / Jog 2 n_set
p1063[0...n]	Setpoint channel speed limit / Setp_chan n_lim
p1080[0...n]	Minimum speed / n_min
p1082[0...n]	Maximum speed / n_max
p1083[0...n]	CO: Speed limit in positive direction of rotation / n_limit pos
p1086[0...n]	CO: Speed limit in negative direction of rotation / n_limit neg
p1091[0...n]	Skip speed 1 / n_skip 1
p1092[0...n]	Skip speed 2 / n_skip 2
p1093[0...n]	Skip speed 3 / n_skip 3
p1094[0...n]	Skip speed 4 / n_skip 4
p1101[0...n]	Skip speed bandwidth / n_skip bandwidth
p1120[0...n]	Ramp-function generator ramp-up time / RFG ramp-up time
p1121[0...n]	Ramp-function generator ramp-down time / RFG ramp-down time
p1123[0...n]	Ramp-function generator minimum ramp-up time / RFG t_RU min
p1127[0...n]	Ramp-function generator minimum ramp-down time / RFG t_RD min
p1130[0...n]	Ramp-function generator initial rounding-off time / RFG t_start_round
p1131[0...n]	Ramp-function generator final rounding-off time / RFG t_end_delay
p1134[0...n]	Ramp-function generator rounding-off type / RFG round-off type
p1135[0...n]	OFF3 ramp-down time / OFF3 t_RD
p1136[0...n]	OFF3 initial rounding-off time / RFGOFF3 t_strt_rnd
p1137[0...n]	OFF3 final rounding-off time / RFG OFF3 t_end_del
p1145[0...n]	Ramp-function generator tracking intensity. / RFG track intens
p1148[0...n]	Ramp-function gen. tolerance for ramp-up and ramp-down active / RFG tol RU/RD act
p1200[0...n]	Flying restart operating mode / FlyRest op_mode
p1202[0...n]	Flying restart search current / FlyRest I_srch

p1203[0...n]	Flying restart search rate factor / FlyRst v_Srch Fact
p1226[0...n]	Threshold for zero speed detection / n_standst n_thresh
p1231[0...n]	DC braking configuration / DCBRK config
p1232[0...n]	DC braking braking current / DCBRK I_brake
p1233[0...n]	DC braking time / DCBRK time
p1234[0...n]	Speed at the start of DC braking / DCBRK n_start
p1240[0...n]	Vdc controller configuration (vector control) / Vdc ctr config vec
p1243[0...n]	Vdc_max controller dynamic factor / Vdc_max dyn_factor
p1245[0...n]	Vdc_min controller switch-in level (kinetic buffering) / Vdc_min on_level
p1247[0...n]	Vdc_min controller dynamic factor (kinetic buffering) / Vdc_min dyn_factor
p1249[0...n]	Vdc_max controller speed threshold / Vdc_max n_thresh
p1250[0...n]	Vdc controller proportional gain / Vdc_ctrl Kp
p1251[0...n]	Vdc controller integral time / Vdc_ctrl Tn
p1252[0...n]	Vdc controller rate time / Vdc_ctrl t_rate
p1255[0...n]	Vdc_min controller time threshold / Vdc_min t_thresh
p1256[0...n]	Vdc_min controller response (kinetic buffering) / Vdc_min response
p1257[0...n]	Vdc_min controller speed threshold / Vdc_min n_thresh
p1271[0...n]	Flying restart maximum frequency for the inhibited direction / FlyRes f_max dir
p1280[0...n]	Vdc controller or Vdc monitoring configuration (U/f) / Vdc_ctr config U/f
p1281[0...n]	Vdc controller configuration / Vdc ctrl config
p1283[0...n]	Vdc_max controller dynamic factor (U/f) / Vdc_max dyn_factor
p1284[0...n]	Vdc_max controller time threshold (U/f) / Vdc_max t_thresh
p1288[0...n]	Vdc_max controller feedback coupling factor ramp-fct. gen. (U/f) / Vdc_max factor RFG
p1290[0...n]	Vdc controller proportional gain (U/f) / Vdc_ctrl Kp
p1291[0...n]	Vdc controller integral time (U/f) / Vdc_ctrl Tn
p1292[0...n]	Vdc controller rate time (U/f) / Vdc_ctrl t_rate
p1300[0...n]	Open-loop/closed-loop control operating mode / Op/cl-lp ctrl_mode
p1302[0...n]	U/f control configuration / U/f config
p1310[0...n]	Starting current (voltage boost) permanent / I_start (Ua) perm
p1311[0...n]	Starting current (voltage boost) when accelerating / I_start accel
p1312[0...n]	Starting current (voltage boost) when starting / I_start start
p1320[0...n]	U/f control programmable characteristic frequency 1 / Uf char f1
p1321[0...n]	U/f control programmable characteristic voltage 1 / Uf char U1
p1322[0...n]	U/f control programmable characteristic frequency 2 / Uf char f2
p1323[0...n]	U/f control programmable characteristic voltage 2 / Uf char U2
p1324[0...n]	U/f control programmable characteristic frequency 3 / Uf char f3
p1325[0...n]	U/f control programmable characteristic voltage 3 / Uf char U3
p1326[0...n]	U/f control programmable characteristic frequency 4 / Uf char f4
p1327[0...n]	U/f control programmable characteristic voltage 4 / Uf char U4
p1331[0...n]	Voltage limiting / U_lim
p1333[0...n]	U/f control FCC starting frequency / U/f FCC f_start
p1334[0...n]	U/f control slip compensation starting frequency / Slip comp start
p1335[0...n]	Slip compensation scaling / Slip comp scal
p1336[0...n]	Slip compensation limit value / Slip comp lim val
p1338[0...n]	U/f mode resonance damping gain / Uf Res_damp gain
p1339[0...n]	U/f mode resonance damping filter time constant / Uf Res_damp T
p1340[0...n]	I_max frequency controller proportional gain / I_max_ctrl Kp
p1341[0...n]	I_max frequency controller integral time / I_max_ctrl Tn
p1345[0...n]	I_max voltage controller proportional gain / I_max_U_ctrl Kp
p1346[0...n]	I_max voltage controller integral time / I_max_U_ctrl Tn
p1349[0...n]	U/f mode resonance damping maximum frequency / Uf res_damp f_max
p1350[0...n]	U/f control soft start / U/f soft start
p1351[0...n]	CO: Motor holding brake starting frequency / Brake f_start
p1382[0...n]	Saturation limit for flux setpoint / Max FluxSaturation
p1400[0...n]	Speed control configuration / n_ctrl config

p1401[0...n]	Flux control configuration / Flux ctrl config
p1402[0...n]	Closed-loop current control and motor model configuration / I_ctrl config
p1416[0...n]	Speed setpoint filter 1 time constant / n_set_filt 1 T
p1452[0...n]	Speed controller speed actual value smoothing time (sensorless) / n_C n_act T_s SL
p1456[0...n]	Speed controller P gain adaptation lower starting point / n_ctrl AdaptKpLow
p1457[0...n]	Speed controller P gain adaptation upper starting point / n_ctrl AdaptKp up
p1458[0...n]	Adaptation factor lower / Adapt_factor lower
p1459[0...n]	Adaptation factor upper / Adapt_factor upper
p1461[0...n]	Speed controller Kp adaptation speed upper scaling / n_ctr Kp n up scal
p1463[0...n]	Speed controller Tn adaptation speed upper scaling / n_ctr Tn n up scal
p1464[0...n]	Speed controller adaptation speed lower / n_ctrl n lower
p1465[0...n]	Speed controller adaptation speed upper / n_ctrl n upper
p1470[0...n]	Speed controller encoderless operation P-gain / n_ctrl SL Kp
p1472[0...n]	Speed controller encoderless operation integral time / n_ctrl SL Tn
p1487[0...n]	Droop compensation torque scaling / Droop M_comp scal
p1488[0...n]	Droop input source / Droop input source
p1489[0...n]	Droop feedback scaling / Droop scal
p1496[0...n]	Acceleration precontrol scaling / a_prectrl scal
p1499[0...n]	Accelerating for torque control scaling / a for M_ctrl scal
p1514[0...n]	Supplementary torque 2 scaling / M_suppl 2 scal
p1517[0...n]	Accelerating torque smoothing time constant / M_accel T_smooth
p1520[0...n]	CO: Torque limit upper / M_max upper
p1521[0...n]	CO: Torque limit lower / M_max lower
p1524[0...n]	CO: Torque limit upper scaling / M_max upper scal
p1525[0...n]	CO: Torque limit lower scaling / M_max lower scal
p1530[0...n]	Power limit motoring / P_max mot
p1531[0...n]	Power limit regenerative / P_max gen
p1553[0...n]	Stall limit scaling / Stall limit scal
p1560[0...n]	Moment of inertia estimator accelerating torque threshold value / J_est M thresh
p1561[0...n]	Moment of inertia estimator change time moment of inertia / J_est t J
p1562[0...n]	Moment of inertia estimator change time load / J_est t load
p1563[0...n]	CO: Mom. of inertia estimator load torque direction of rotation pos. / J_est M pos
p1564[0...n]	CO: Mom. of inertia estimator load torque direction of rotation neg. / J_est M neg
r1566[0...n]	Flux reduction torque factor transition value / Flux red M trans
p1567[0...n]	Magnetization rate time scaling / Mag Tv scale
p1570[0...n]	CO: Flux setpoint / Flux setp
p1573[0...n]	Flux threshold value magnetizing / Flux thresh magnet
p1574[0...n]	Voltage reserve dynamic / U_reserve dyn
p1575[0...n]	Voltage target value limit / U_tgt val lim
p1578[0...n]	Flux reduction flux decrease time constant / Flux red dec T
p1579[0...n]	Flux reduction flux build-up time constant / Flux red incr T
p1580[0...n]	Efficiency optimization / Efficiency opt
p1581[0...n]	Flux reduction factor / Flux red factor
p1582[0...n]	Flux setpoint smoothing time / Flux setp T_smth
p1584[0...n]	Field weakening operation flux setpoint smoothing time / Field weak T_smth
p1586[0...n]	Field weakening characteristic scaling / Field weak scal
p1590[0...n]	Flux controller P gain / Flux controller Kp
p1594[0...n]	Field-weakening controller P gain / Field_ctrl Kp
p1595[0...n]	Field weakening controller additional setpoint / Field_ctr add_setp
p1596[0...n]	Field weakening controller integral-action time / Field_ctrl Tn
p1601[0...n]	Current injection ramp time / I_inject t_ramp
p1610[0...n]	Torque setpoint static (sensorless) / M_set static
p1611[0...n]	Additional acceleration torque (sensorless) / M_suppl_accel
p1616[0...n]	Current setpoint smoothing time / I_set T_smooth
p1654[0...n]	Curr. setpoint torque-gen. smoothing time field weakening range / Isq_s T_smth FW

p1702[0...n]	Isd current controller precontrol scaling / Isd_ctr_prectrScal
p1703[0...n]	Isq current controller precontrol scaling / Isq_ctr_prectrScal
p1715[0...n]	Current controller P gain / I_ctrl Kp
p1717[0...n]	Current controller integral-action time / I_ctrl Tn
p1720[0...n]	Current controller d axis p gain / Id_ctrl Kp
p1722[0...n]	Current controller d axis integral time / I_ctrl d-axis Tn
p1726[0...n]	Quadrature arm decoupling scaling / Transv_decpl scal
p1727[0...n]	Quadrature arm decoupling at voltage limit scaling / TrnsvDecplVmaxScal
p1730[0...n]	Isd controller integral component shutdown threshold / Isd ctrl Tn shutd
p1731[0...n]	Isd controller combination current time component / Isd ctr I_combi T1
p1740[0...n]	Gain resonance damping for encoderless closed-loop control / Gain res_damp
p1745[0...n]	Motor model error threshold stall detection / MotMod ThreshStall
p1749[0...n]	Motor model increase changeover speed encoderless operation / Incr n_chng no enc
p1750[0...n]	Motor model configuration / MotMod config
p1755[0...n]	Motor model changeover speed encoderless operation / MotMod n_chgSnsorl
p1758[0...n]	Motor model changeover delay time closed/open-loop control / MotMod t_cl_op
p1759[0...n]	Motor model changeover delay time open/closed-loop control / MotMod t_op_cl
p1764[0...n]	Motor model without encoder speed adaptation Kp / MotMod woE n_adaKp
p1767[0...n]	Motor model without encoder speed adaptation Tn / MotMod woE n_adaTn
p1769[0...n]	Motor model changeover delay time closed-loop control / MotMod t_cl_ctrl
p1774[0...n]	Motor model offset voltage compensation alpha / MotMod offs comp A
p1775[0...n]	Motor model offset voltage compensation beta / MotMod offs comp B
p1780[0...n]	Motor model adaptation configuration / MotMod adapt conf
p1784[0...n]	Motor model feedback scaling / MotMod fdbk scal
p1785[0...n]	Motor model Lh adaptation Kp / MotMod Lh Kp
p1786[0...n]	Motor model Lh adaptation integral time / MotMod Lh Tn
r1787[0...n]	Motor model Lh adaptation corrective value / MotMod Lh corr
p1795[0...n]	Motor model kT adaptation integral time / MotMod kT Tn
r1797[0...n]	Motor model kT adaptation corrective value / MotMod kT corr
p1800[0...n]	Pulse frequency setpoint / Pulse freq setp
p1802[0...n]	Modulator mode / Modulator mode
p1803[0...n]	Maximum modulation depth / Modulat depth max
p1806[0...n]	Filter time constant Vdc correction / T_filt Vdc_corr
p1820[0...n]	Reverse the output phase sequence / Outp_ph_seq rev
p1909[0...n]	Motor data identification control word / MotID STW
p1959[0...n]	Rotating measurement configuration / Rot meas config
p1980[0...n]	PolID technique / PolID technique
p1999[0...n]	Ang. commutation offset calibr. and PolID scaling / Com_ang_offs scal
p2140[0...n]	Hysteresis speed 2 / n_hysteresis 2
p2141[0...n]	Speed threshold 1 / n_thresh val 1
p2142[0...n]	Hysteresis speed 1 / n_hysteresis 1
p2149[0...n]	Monitoring configuration / Monit config
p2150[0...n]	Hysteresis speed 3 / n_hysteresis 3
p2152[0...n]	Delay for comparison n > n_max / Del n > n_max
p2153[0...n]	Speed actual value filter time constant / n_act_filt T
p2155[0...n]	Speed threshold 2 / n_thresh val 2
p2156[0...n]	On delay comparison value reached / t_on cmptr val rchd
p2157[0...n]	Speed threshold 5 / n_thresh val 5
p2158[0...n]	Delay for n_act comparison with speed threshold value 5 / Del compar n_5
p2159[0...n]	Speed threshold 6 / n_thresh val 6
p2160[0...n]	Delay for n_act comparison with speed threshold value 6 / Del compar n_6
p2161[0...n]	Speed threshold 3 / n_thresh val 3
p2162[0...n]	Hysteresis speed n_act > n_max / Hyst n_act>n_max
p2163[0...n]	Speed threshold 4 / n_thresh val 4
p2164[0...n]	Hysteresis speed 4 / n_hysteresis 4

p2165[0...n]	Load monitoring stall monitoring upper threshold / Stall_mon up thr
p2166[0...n]	Off delay $n_{act} = n_{set} / t_{del_off}$ $n_i = n_{set}$
p2167[0...n]	Switch-on delay $n_{act} = n_{set} / t_{on}$ $n_{act} = n_{set}$
p2168[0...n]	Load monitoring stall monitoring torque threshold / Stall_mon M_thresh
p2170[0...n]	Current threshold value / I_thres
p2171[0...n]	Current threshold value reached delay time / I_thresh rch t_del
p2172[0...n]	DC link voltage threshold value / Vdc thresh val
p2173[0...n]	DC link voltage comparison delay time / t_del Vdc
p2174[0...n]	Torque threshold value 1 / M_thresh val 1
p2175[0...n]	Motor blocked speed threshold / Mot lock n_thresh
p2176[0...n]	Torque threshold value comparison delay time / M_thrsh comp T_del
p2177[0...n]	Motor blocked delay time / Mot lock t_del
p2178[0...n]	Motor stalled delay time / Mot stall t_del
p2179[0...n]	Output load identification current limit / Outp_Id iden I_lim
p2180[0...n]	Output load detection delay time / Out_load det t_del
p2181[0...n]	Load monitoring response / Load monit resp
p2182[0...n]	Load monitoring speed threshold value 1 / n_thresh 1
p2183[0...n]	Load monitoring speed threshold value 2 / n_thresh 2
p2184[0...n]	Load monitoring speed threshold value 3 / n_thresh 3
p2185[0...n]	Load monitoring torque threshold 1 upper / M_thresh 1 upper
p2186[0...n]	Load monitoring torque threshold 1 lower / M_thresh 1 lower
p2187[0...n]	Load monitoring torque threshold 2 upper / M_thresh 2 upper
p2188[0...n]	Load monitoring torque threshold 2 lower / M_thresh 2 lower
p2189[0...n]	Load monitoring torque threshold 3 upper / M_thresh 3 upper
p2190[0...n]	Load monitoring torque threshold 3 lower / M_thresh 3 lower
p2191[0...n]	Load monitoring torque threshold no load / M_thresh no load
p2192[0...n]	Load monitoring delay time / Load monit t_del
p2193[0...n]	Load monitoring configuration / Load monit config
p2194[0...n]	Torque threshold value 2 / M_thresh val 2
p2195[0...n]	Torque utilization switch-off delay / M_util t_off
p2196[0...n]	Torque utilization scaling / M_util scal
p2201[0...n]	CO: Technology controller fixed value 1 / Tec_ctrl fix val1
p2202[0...n]	CO: Technology controller fixed value 2 / Tec_ctr fix val 2
p2203[0...n]	CO: Technology controller fixed value 3 / Tec_ctr fix val 3
p2204[0...n]	CO: Technology controller fixed value 4 / Tec_ctr fix val 4
p2205[0...n]	CO: Technology controller fixed value 5 / Tec_ctr fix val 5
p2206[0...n]	CO: Technology controller fixed value 6 / Tec_ctr fix val 6
p2207[0...n]	CO: Technology controller fixed value 7 / Tec_ctr fix val 7
p2208[0...n]	CO: Technology controller fixed value 8 / Tec_ctr fix val 8
p2209[0...n]	CO: Technology controller fixed value 9 / Tec_ctr fix val 9
p2210[0...n]	CO: Technology controller fixed value 10 / Tec_ctr fix val 10
p2211[0...n]	CO: Technology controller fixed value 11 / Tec_ctr fix val 11
p2212[0...n]	CO: Technology controller fixed value 12 / Tec_ctr fix val 12
p2213[0...n]	CO: Technology controller fixed value 13 / Tec_ctr fix val 13
p2214[0...n]	CO: Technology controller fixed value 14 / Tec_ctr fix val 14
p2215[0...n]	CO: Technology controller fixed value 15 / Tec_ctr fix val 15
p2216[0...n]	Technology controller fixed value selection method / Tec_ctr FixVal sel
p2230[0...n]	Technology controller motorized potentiometer configuration / Tec_ctr mop config
p2237[0...n]	Technology controller motorized potentiometer maximum value / Tec_ctrl mop max
p2238[0...n]	Technology controller motorized potentiometer minimum value / Tec_ctrl mop min
p2240[0...n]	Technology controller motorized potentiometer starting value / Tec_ctrl mop start
p2247[0...n]	Technology controller motorized potentiometer ramp-up time / Tec_ctr mop t_r-up
p2248[0...n]	Technology controller motorized potentiometer ramp-down time / Tec_ctrMop t_rdown
p2900[0...n]	CO: Fixed value 1 [%] / Fixed value 1 [%]
p2901[0...n]	CO: Fixed value 2 [%] / Fixed value 2 [%]

p2930[0...n]	CO: Fixed value M [Nm] / Fixed value M [Nm]
p3231[0...n]	Load monitoring speed deviation / Load monit n_dev
p3233[0...n]	Torque actual value filter time constant / M_act_filt T
p3315[0...n]	Efficiency optimization 2 minimum flux limit value / Min flux lim val
p3316[0...n]	Efficiency optimization 2 maximum flux limit value / Max flux lim val
p3320[0...n]	Fluid flow machine power point 1 / Fluid_mach P1
p3321[0...n]	Fluid flow machine speed point 1 / Fluid_mach n1
p3322[0...n]	Fluid flow machine power point 2 / Fluid_mach P2
p3323[0...n]	Fluid flow machine speed point 2 / Fluid_mach n2
p3324[0...n]	Fluid flow machine power point 3 / Fluid_mach P3
p3325[0...n]	Fluid flow machine speed point 3 / Fluid_mach n3
p3326[0...n]	Fluid flow machine power point 4 / Fluid_mach P4
p3327[0...n]	Fluid flow machine speed point 4 / Fluid_mach n4
p3328[0...n]	Fluid flow machine power point 5 / Fluid_mach P5
p3329[0...n]	Fluid flow machine speed point 5 / Fluid_mach n5
p3820[0...n]	Friction characteristic value n0 / Friction n0
p3821[0...n]	Friction characteristic value n1 / Friction n1
p3822[0...n]	Friction characteristic value n2 / Friction n2
p3823[0...n]	Friction characteristic value n3 / Friction n3
p3824[0...n]	Friction characteristic value n4 / Friction n4
p3825[0...n]	Friction characteristic value n5 / Friction n5
p3826[0...n]	Friction characteristic value n6 / Friction n6
p3827[0...n]	Friction characteristic value n7 / Friction n7
p3828[0...n]	Friction characteristic value n8 / Friction n8
p3829[0...n]	Friction characteristic value n9 / Friction n9
p3830[0...n]	Friction characteristic value M0 / Friction M0
p3831[0...n]	Friction characteristic value M1 / Friction M1
p3832[0...n]	Friction characteristic value M2 / Friction M2
p3833[0...n]	Friction characteristic value M3 / Friction M3
p3834[0...n]	Friction characteristic value M4 / Friction M4
p3835[0...n]	Friction characteristic value M5 / Friction M5
p3836[0...n]	Friction characteristic value M6 / Friction M6
p3837[0...n]	Friction characteristic value M7 / Friction M7
p3838[0...n]	Friction characteristic value M8 / Friction M8
p3839[0...n]	Friction characteristic value M9 / Friction M9
p3846[0...n]	Friction characteristic record ramp-up/ramp-down time / Frict rec t_RU/RD
p3847[0...n]	Friction characteristic record warm-up time / Frict rec t_warm
p3855[0...n]	DC quantity controller configuration / Rect_ctrl config
p3857[0...n]	DC quantity controller P gain / DC_ctrl Kp
p3858[0...n]	DC quantity controller integral time / DC_ctrl Tn
r3925[0...n]	Identification final display / Ident final_disp
r3926[0...n]	Voltage generation alternating base voltage amplitude / U_gen altern base
r3927[0...n]	Motor data identification control word / MotID STW
r3928[0...n]	Rotating measurement configuration / Rot meas config
r3929[0...n]	Motor data identification modulated voltage generation / MotID U_gen mod
p5271[0...n]	Online tuning configuration controller / Ot config ctrl
p5272[0...n]	Online tuning dynamic factor / Ot dyn_factor
p5273[0...n]	Online tuning dynamic factor load / Ot dyn_factor load
p5275[0...n]	Online tuning dynamic time constant / Ot dyn T
p5310[0...n]	Moment of inertia precontrol configuration / J_est config
r5311[0...n]	Moment of inertia precontrol status word / J_prectrl ZSW
p5312[0...n]	Moment of inertia precontrol linear positive / J_est lin pos
p5313[0...n]	Moment of inertia precontrol constant positive / J_est const pos
p5314[0...n]	Moment of inertia precontrol linear negative / J_est lin neg
p5315[0...n]	Moment of inertia precontrol constant negative / J_est const neg

p5316[0...n]	Moment of inertia precontrol change time moment of inertia / J_prectrl t J
p5350[0...n]	Mot_temp_mod 1/3 boost factor at standstill / Standst boost_fact
p5390[0...n]	Mot_temp_mod 1/3 alarm threshold / A thresh
p5391[0...n]	Mot_temp_mod 1/3 fault threshold / F thresh
r5398[0...n]	Mot_temp_mod 3 alarm threshold image p5390 / A thr image p5390
r5399[0...n]	Mot_temp_mod 3 fault threshold image p5391 / F thr image p5391

2.4 BICO parameters (connectors/binectors)

2.4.1 Binector inputs (BI)

Product: G115D, Version: 4715218, Language: eng, Type: BI

p0043	BI: Enable energy usage display / Enab energy usage
p0738	BI: CU signal source for terminal DI/DO 24 / CU s_s DI/DO 24
p0739	BI: CU signal source for terminal DI/DO 25 / CU s_s DI/DO 25
p0806	BI: Inhibit master control / PcCtrl inhibit
p0810	BI: Command data set selection CDS bit 0 / CDS select., bit 0
p0811	BI: Command data set selection CDS bit 1 / CDS select., bit 1
p0820[0...n]	BI: Drive Data Set selection DDS bit 0 / DDS select., bit 0
p0821[0...n]	BI: Drive Data Set selection DDS bit 1 / DDS select., bit 1
p0840[0...n]	BI: ON / OFF (OFF1) / ON / OFF (OFF1)
p0844[0...n]	BI: No coast-down / coast-down (OFF2) signal source 1 / OFF2 S_s 1
p0845[0...n]	BI: No coast-down / coast-down (OFF2) signal source 2 / OFF2 S_s 2
p0848[0...n]	BI: No Quick Stop / Quick Stop (OFF3) signal source 1 / OFF3 S_s 1
p0849[0...n]	BI: No Quick Stop / Quick Stop (OFF3) signal source 2 / OFF3 S_s 2
p0852[0...n]	BI: Enable operation/inhibit operation / Enable operation
p0854[0...n]	BI: Control by PLC/no control by PLC / Master ctrl by PLC
p0855[0...n]	BI: Unconditionally release holding brake / Uncond open brake
p0856[0...n]	BI: Enable speed controller / n_ctrl enable
p0858[0...n]	BI: Unconditionally close holding brake / Uncond close brake
p0860	BI: Line contactor feedback signal / Line contact feedb
p0870	BI: Close main contactor / Close main cont
p0897	BI: Parking axis selection / Parking axis sel
p1020[0...n]	BI: Fixed speed setpoint selection Bit 0 / n_set_fixed Bit 0
p1021[0...n]	BI: Fixed speed setpoint selection Bit 1 / n_set_fixed Bit 1
p1022[0...n]	BI: Fixed speed setpoint selection Bit 2 / n_set_fixed Bit 2
p1023[0...n]	BI: Fixed speed setpoint selection Bit 3 / n_set_fixed Bit 3
p1035[0...n]	BI: Motorized potentiometer setpoint raise / Mop raise
p1036[0...n]	BI: Motorized potentiometer lower setpoint / Mop lower
p1039[0...n]	BI: Motorized potentiometer inversion / MotP inv
p1041[0...n]	BI: Motorized potentiometer manual/automatic / Mop manual/auto
p1043[0...n]	BI: Motorized potentiometer accept setting value / MotP acc set val
p1055[0...n]	BI: Jog bit 0 / Jog bit 0
p1056[0...n]	BI: Jog bit 1 / Jog bit 1
p1108[0...n]	BI: Total setpoint selection / Total setp sel
p1110[0...n]	BI: Inhibit negative direction / Inhib neg dir
p1111[0...n]	BI: Inhibit positive direction / Inhib pos dir
p1113[0...n]	BI: Setpoint inversion / Setp inv
p1122[0...n]	BI: Bypass ramp-function generator / Bypass RFG
p1140[0...n]	BI: Enable ramp-function generator/inhibit ramp-function generator / Enable RFG
p1141[0...n]	BI: Continue ramp-function generator/freeze ramp-function generator / Continue RFG
p1142[0...n]	BI: Enable setpoint/inhibit setpoint / Setpoint enable
p1143[0...n]	BI: Ramp-function generator, accept setting value / RFG accept set v
p1201[0...n]	BI: Flying restart enable signal source / Fly_res enab s_s
p1230[0...n]	BI: DC braking activation / DC brake act
p1476[0...n]	BI: Speed controller hold integrator / n_ctrl integ stop
p1477[0...n]	BI: Speed controller set integrator value / n_ctrl integ set
p1492[0...n]	BI: Droop feedback enable / Droop enable
p1501[0...n]	BI: Change over between closed-loop speed/torque control / Changeov n/M_ctrl
p1502[0...n]	BI: Freeze moment of inertia estimator / J_estim freeze

p2080[0...15]	BI: Binector-connector converter status word 1 / Bin/con ZSW1
p2081[0...15]	BI: Binector-connector converter status word 2 / Bin/con ZSW2
p2082[0...15]	BI: Binector-connector converter status word 3 / Bin/con ZSW3
p2083[0...15]	BI: Binector-connector converter status word 4 / Bin/con ZSW4
p2084[0...15]	BI: Binector-connector converter status word 5 / Bin/con ZSW5
p2103[0...n]	BI: 1st acknowledge faults / 1st acknowledge
p2104[0...n]	BI: 2nd acknowledge faults / 2nd acknowledge
p2105[0...n]	BI: 3rd acknowledge faults / 3rd acknowledge
p2106[0...n]	BI: External fault 1 / External fault 1
p2107[0...n]	BI: External fault 2 / External fault 2
p2108[0...n]	BI: External fault 3 / External fault 3
p2112[0...n]	BI: External alarm 1 / External alarm 1
p2116[0...n]	BI: External alarm 2 / External alarm 2
p2117[0...n]	BI: External alarm 3 / External alarm 3
p2144[0...n]	BI: Motor stall monitoring enable (negated) / Mot stall enab neg
p2148[0...n]	BI: RFG active / RFG active
p2200[0...n]	BI: Technology controller enable / Tec_ctrl enable
p2220[0...n]	BI: Technology controller fixed value selection bit 0 / Tec_ctrl sel bit 0
p2221[0...n]	BI: Technology controller fixed value selection bit 1 / Tec_ctrl sel bit 1
p2222[0...n]	BI: Technology controller fixed value selection bit 2 / Tec_ctrl sel bit 2
p2223[0...n]	BI: Technology controller fixed value selection bit 3 / Tec_ctrl sel bit 3
p2235[0...n]	BI: Technology controller motorized potentiometer raise setpoint / Tec_ctrl mop raise
p2236[0...n]	BI: Technology controller motorized potentiometer lower setpoint / Tec_ctrl mop lower
p2286[0...n]	BI: Hold technology controller integrator / Tec_ctr integ hold
p2290[0...n]	BI: Technology controller limiting enable / Tec_ctrl lim enab
p3111[0...n]	BI: External fault 3 enable / Ext fault 3 enab
p3112[0...n]	BI: External fault 3 enable negated / Ext flt 3 enab neg
p3232[0...n]	BI: Load monitoring failure detection / Load_moni fail_det
p3330[0...n]	BI: 2/3 wire control command 1 / 2/3 wire cmd 1
p3331[0...n]	BI: 2/3 wire control command 2 / 2/3 wire cmd 2
p3332[0...n]	BI: 2/3 wire control command 3 / 2/3 wire cmd 3
p3384	BI: Stop sensor positive direction signal source / Stop sens pos s_s
p3385	BI: Stop sensor negative direction signal source / Stop sens neg s_s
p3386	BI: Stop sensor center signal source / Stop sens mid s_s
p3387	BI: Low speed sensor positive direction signal source / Low sens pos s_s
p3388	BI: Low speed sensor negative direction signal source / Low sens neg s_s
p3389	BI: Low speed sensor center signal source / Low sens cntr s_s
p3390	BI: Stop/low speed sensor bypass signal source / Sensor bypass s_s
p3391	BI: Stop/low speed sensor bypass manual operation signal source / Sens bypass manual
p5614	BI: Pe set switching on inhibited signal source / Pe sw-on_inh s_s
p8542[0...15]	BI: Active STW1 in the BOP/IOP manual mode / STW1 act OP
p8558	BI: Select IOP manual mode / Sel IOP man mode
p8598	BI: LRC jog bit 0 / LRC jog bit 0
p8599	BI: LRC jog bit 1 / LRC jog bit 1
p20030[0...3]	BI: AND 0 inputs / AND 0 inputs
p20034[0...3]	BI: AND 1 inputs / AND 1 inputs
p20038[0...3]	BI: AND 2 inputs / AND 2 inputs
p20042[0...3]	BI: AND 3 inputs / AND 3 inputs
p20046[0...3]	BI: OR 0 inputs / OR 0 inputs
p20050[0...3]	BI: OR 1 inputs / OR 1 inputs
p20054[0...3]	BI: OR 2 inputs / OR 2 inputs
p20058[0...3]	BI: OR 3 inputs / OR 3 inputs
p20062[0...3]	BI: XOR 0 inputs / XOR 0 inputs
p20066[0...3]	BI: XOR 1 inputs / XOR 1 inputs
p20070[0...3]	BI: XOR 2 inputs / XOR 2 inputs

p20074[0...3]	Bl: XOR 3 inputs / XOR 3 inputs
p20078	Bl: NOT 0 input I / NOT 0 input I
p20082	Bl: NOT 1 input I / NOT 1 input I
p20086	Bl: NOT 2 input I / NOT 2 input I
p20090	Bl: NOT 3 input I / NOT 3 input I
p20138	Bl: MFP 0 input pulse I / MFP 0 inp_pulse I
p20143	Bl: MFP 1 input pulse I / MFP 1 inp_pulse I
p20148	Bl: PCL 0 input pulse I / PCL 0 inp_pulse I
p20153	Bl: PCL 1 input pulse I / PCL 1 inp_pulse I
p20158	Bl: PDE 0 input pulse I / PDE 0 inp_pulse I
p20163	Bl: PDE 1 input pulse I / PDE 1 inp_pulse I
p20168	Bl: PDF 0 input pulse I / PDF 0 inp_pulse I
p20173	Bl: PDF 1 input pulse I / PDF 1 inp_pulse I
p20178[0...1]	Bl: PST 0 inputs / PST 0 inputs
p20183[0...1]	Bl: PST 1 inputs / PST 1 inputs
p20188[0...1]	Bl: RSR 0 inputs / RSR 0 inputs
p20193[0...1]	Bl: RSR 1 inputs / RSR 1 inputs
p20198[0...3]	Bl: DFR 0 inputs / DFR 0 inputs
p20203[0...3]	Bl: DFR 1 inputs / DFR 1 inputs
p20208[0...1]	Bl: BSW 0 inputs / BSW 0 inputs
p20209	Bl: BSW 0 switch setting I / BSW 0 sw_setting
p20213[0...1]	Bl: BSW 1 inputs / BSW 1 inputs
p20214	Bl: BSW 1 switch setting I / BSW 1 sw_setting
p20219	Bl: NSW 0 switch setting I / NSW 0 sw_setting
p20224	Bl: NSW 1 switch setting I / NSW 1 sw_setting
p20245	Bl: PT1 0 accept setting value S / PT1 0 acc set val
p20251	Bl: PT1 1 accept setting value S / PT1 1 acc set val
p20260	Bl: INT 0 accept setting value S / INT 0 acc set val
p20300	Bl: NOT 4 input I / NOT 4 input I
p20304	Bl: NOT 5 input I / NOT 5 input I
p20324[0...1]	Bl: RSR 2 inputs / RSR 2 inputs
p20329[0...3]	Bl: DFR 2 inputs / DFR 2 inputs
p20334	Bl: PDE 2 input pulse I / PDE 2 inp_pulse I
p20339	Bl: PDE 3 input pulse I / PDE 3 inp_pulse I
p20344	Bl: PDF 2 input pulse I / PDF 2 inp_pulse I
p20349	Bl: PDF 3 input pulse I / PDF 3 inp_pulse I
p20354	Bl: MFP 2 input pulse I / MFP 2 inp_pulse I
p20359	Bl: MFP 3 input pulse I / MFP 3 inp_pulse I

2.4.2 Connector inputs (CI)

Product: G115D, Version: 4715218, Language: eng, Type: CI

p0480[0...2]	Cl: Encoder control word Gn_STW signal source / Enc Gn_STW s_s
p0641[0...n]	Cl: Current limit, variable / Curr lim var
p1042[0...n]	Cl: Motorized potentiometer automatic setpoint / Mop auto setpoint
p1044[0...n]	Cl: Motorized potentiometer setting value / Mop set val
p1051[0...n]	Cl: Speed limit RFG positive direction of rotation / n_limit RFG pos
p1052[0...n]	Cl: Speed limit RFG negative direction of rotation / n_limit RFG neg
p1070[0...n]	Cl: Main setpoint / Main setpoint
p1071[0...n]	Cl: Main setpoint scaling / Main setp scal
p1075[0...n]	Cl: Supplementary setp / Suppl setp
p1076[0...n]	Cl: Supplementary setpoint scaling / Suppl setp scal
p1085[0...n]	Cl: Speed limit in positive direction of rotation / n_limit pos
p1088[0...n]	Cl: Speed limit in negative direction of rotation / n_limit neg

p1098[0...n]	Cl: Skip speed scaling / n_skip scal
p1106[0...n]	Cl: Minimum speed signal source / n_min s_s
p1109[0...n]	Cl: Total setpoint / Total setp
p1138[0...n]	Cl: Ramp-function generator ramp-up time scaling / RFG t_RU scal
p1139[0...n]	Cl: Ramp-function generator ramp-down time scaling / RFG t_RD scal
p1144[0...n]	Cl: Ramp-function generator setting value / RFG setting value
p1155[0...n]	Cl: Speed controller speed setpoint 1 / n_ctrl n_set 1
p1160[0...n]	Cl: Speed controller speed setpoint 2 / n_ctrl n_set 2
p1330[0...n]	Cl: U/f control independent voltage setpoint / Uf U_set independ.
p1352[0...n]	Cl: Motor holding brake starting frequency signal source / Brake f_start
p1455[0...n]	Cl: Speed controller P gain adaptation signal / n_ctr adapt_sig Kp
p1466[0...n]	Cl: Speed controller P-gain scaling / n_ctrl Kp scal
p1475[0...n]	Cl: Speed controller torque setting value for motor holding brake / n_ctrl M_sv MHB
p1478[0...n]	Cl: Speed controller integrator setting value / n_ctr integ_setVal
p1479[0...n]	Cl: Speed controller integrator setting value scaling / n_ctrl I_val scal
p1486[0...n]	Cl: Droop compensation torque / Droop M_comp
p1503[0...n]	Cl: Torque setpoint / M_set
p1511[0...n]	Cl: Supplementary torque 1 / M_suppl 1
p1512[0...n]	Cl: Supplementary torque 1 scaling / M_suppl 1 scal
p1513[0...n]	Cl: Supplementary torque 2 / M_suppl 2
p1522[0...n]	Cl: Torque limit upper / M_max upper
p1523[0...n]	Cl: Torque limit lower / M_max lower
p1528[0...n]	Cl: Torque limit upper scaling / M_max upper scal
p1529[0...n]	Cl: Torque limit lower scaling / M_max lower scal
p1552[0...n]	Cl: Torque limit upper scaling without offset / M_max up w/o offs
p1554[0...n]	Cl: Torque limit lower scaling without offset / M_max low w/o offs
p2016[0...3]	Cl: Comm IF USS PZD send word / Comm USS send word
p2051[0...16]	Cl: PROFIdrive PZD send word / PZD send word
p2061[0...15]	Cl: PROFIdrive PZD send double word / PZD send DW
p2099[0...1]	Cl: Connector-binector converter signal source / Con/bin s_s
p2151[0...n]	Cl: Speed setpoint for messages/signals / n_set for msg
p2253[0...n]	Cl: Technology controller setpoint 1 / Tec_ctrl setp 1
p2254[0...n]	Cl: Technology controller setpoint 2 / Tec_ctrl setp 2
p2264[0...n]	Cl: Technology controller actual value / Tec_ctrl act val
p2289[0...n]	Cl: Technology controller precontrol signal / Tec_ctr prectr_sig
p2296[0...n]	Cl: Technology controller output scaling / Tec_ctrl outp scal
p2297[0...n]	Cl: Technology controller maximum limit signal source / Tec_ctrMaxLim s_s
p2298[0...n]	Cl: Technology controller minimum limit signal source / Tec_ctrl min_l s_s
p2299[0...n]	Cl: Technology controller limit offset / Tech_ctrl lim offs
p3230[0...n]	Cl: Load monitoring speed actual value / Load monit n_act
p3397	Cl: Rapid traverse setpoint signal source / Rap trav setp s_s
p3398	Cl: Low speed setpoint signal source / Low speed setp
p8543	Cl: Active speed setpoint in the BOP/IOP manual mode / N_act act OP
p20094[0...3]	Cl: ADD 0 inputs / ADD 0 inputs
p20098[0...3]	Cl: ADD 1 inputs / ADD 1 inputs
p20102[0...1]	Cl: SUB 0 inputs / SUB 0 inputs
p20106[0...1]	Cl: SUB 1 inputs / SUB 1 inputs
p20110[0...3]	Cl: MUL 0 inputs / MUL 0 inputs
p20114[0...3]	Cl: MUL 1 inputs / MUL 1 inputs
p20118[0...1]	Cl: DIV 0 inputs / DIV 0 inputs
p20123[0...1]	Cl: DIV 1 inputs / DIV 1 inputs
p20128	Cl: AVA 0 input X / AVA 0 input X
p20133	Cl: AVA 1 input X / AVA 1 input X
p20218[0...1]	Cl: NSW 0 inputs / NSW 0 inputs
p20223[0...1]	Cl: NSW 1 inputs / NSW 1 inputs

p20228	CI: LIM 0 input X / LIM 0 input X
p20236	CI: LIM 1 input X / LIM 1 input X
p20244[0...1]	CI: PT1 0 inputs / PT1 0 inputs
p20250[0...1]	CI: PT1 1 inputs / PT1 1 inputs
p20256[0...1]	CI: INT 0 inputs / INT 0 inputs
p20266	CI: LVM 0 input X / LVM 0 input X
p20275	CI: LVM 1 input X / LVM 1 input X
p20284	CI: DIF 0 input X / DIF 0 input X
p20308[0...3]	CI: ADD 2 inputs / ADD 2 inputs
p20312[0...1]	CI: NCM 0 inputs / NCM 0 inputs
p20318[0...1]	CI: NCM 1 inputs / NCM 1 inputs
p20372	CI: PLI 0 input X / PLI 0 input X
p20378	CI: PLI 1 input X / PLI 1 input X

2.4.3 Binector outputs (BO)

Product: G115D, Version: 4715218, Language: eng, Type: BO

r0807.0	BO: Master control active / PcCtrl active
r1025.0	BO: Fixed speed setpoint status / n_setp_fix status
r2043.0...2	BO: PROFIdrive PZD state / PD PZD state
r2090.0...15	BO: PROFIdrive PZD1 receive bit-serial / PZD1 recv bitw
r2091.0...15	BO: PROFIdrive PZD2 receive bit-serial / PZD2 recv bitw
r2092.0...15	BO: PROFIdrive PZD3 receive bit-serial / PZD3 recv bitw
r2093.0...15	BO: PROFIdrive PZD4 receive bit-serial / PZD4 recv bitw
r2094.0...15	BO: Connector-binector converter binector output / Con/bin outp
r2095.0...15	BO: Connector-binector converter binector output / Con/bin outp
r8540.0...15	BO: STW1 from IOP in the manual mode / STW1 IOP
r9935.0	BO: POWER ON delay signal / POWER ON t_delay
r20031	BO: AND 0 output Q / AND 0 output Q
r20035	BO: AND 1 output Q / AND 1 output Q
r20039	BO: AND 2 output Q / AND 2 output Q
r20043	BO: AND 3 output Q / AND 3 output Q
r20047	BO: OR 0 output Q / OR 0 output Q
r20051	BO: OR 1 output Q / OR 1 output Q
r20055	BO: OR 2 output Q / OR 2 output Q
r20059	BO: OR 3 output Q / OR 3 output Q
r20063	BO: XOR 0 output Q / XOR 0 output Q
r20067	BO: XOR 1 output Q / XOR 1 output Q
r20071	BO: XOR 2 output Q / XOR 2 output Q
r20075	BO: XOR 3 output Q / XOR 3 output Q
r20079	BO: NOT 0 inverted output / NOT 0 inv output
r20083	BO: NOT 1 inverted output / NOT 1 inv output
r20087	BO: NOT 2 inverted output / NOT 2 inv output
r20091	BO: NOT 3 inverted output / NOT 3 inv output
r20120	BO: DIV 0 divisor is zero QF / DIV 0 divisor=0 QF
r20125	BO: DIV 1 divisor is zero QF / DIV 1 divisor=0 QF
r20130	BO: AVA 0 input negative SN / AVA 0 input neg SN
r20135	BO: AVA 1 input negative SN / AVA 1 input neg SN
r20140	BO: MFP 0 output Q / MFP 0 output Q
r20145	BO: MFP 1 output Q / MFP 1 output Q
r20150	BO: PCL 0 output Q / PCL 0 output Q
r20155	BO: PCL 1 output Q / PCL 1 output Q
r20160	BO: PDE 0 output Q / PDE 0 output Q
r20165	BO: PDE 1 output Q / PDE 1 output Q

r20170	BO: PDF 0 output Q / PDF 0 output Q
r20175	BO: PDF 1 output Q / PDF 1 output Q
r20180	BO: PST 0 output Q / PST 0 output Q
r20185	BO: PST 1 output Q / PST 1 output Q
r20189	BO: RSR 0 output Q / RSR 0 output Q
r20190	BO: RSR 0 inverted output QN / RSR 0 inv outp QN
r20194	BO: RSR 1 output Q / RSR 1 output Q
r20195	BO: RSR 1 inverted output QN / RSR 1 inv outp QN
r20199	BO: DFR 0 output Q / DFR 0 output Q
r20200	BO: DFR 0 inverted output QN / DFR 0 inv outp QN
r20204	BO: DFR 1 output Q / DFR 1 output Q
r20205	BO: DFR 1 inverted output QN / DFR 1 inv outp QN
r20210	BO: BSW 0 output Q / BSW 0 output Q
r20215	BO: BSW 1 output Q / BSW 1 output Q
r20232	BO: LIM 0 input quantity at the upper limit QU / LIM 0 QU
r20233	BO: LIM 0 input quantity at the lower limit QL / LIM 0 QL
r20240	BO: LIM 1 input quantity at the upper limit QU / LIM 1 QU
r20241	BO: LIM 1 input quantity at the lower limit QL / LIM 1 QL
r20262	BO: INT 0 integrator at the upper limit QU / INT 0 QU
r20263	BO: INT 0 integrator at the lower limit QL / INT 0 QL
r20270	BO: LVM 0 input quantity above interval QU / LVM 0 X above QU
r20271	BO: LVM 0 input quantity within interval QM / LVM 0 X within QM
r20272	BO: LVM 0 input quantity below interval QL / LVM 0 X below QL
r20279	BO: LVM 1 input quantity above interval QU / LVM 1 X above QU
r20280	BO: LVM 1 input quantity within interval QM / LVM 1 X within QM
r20281	BO: LVM 1 input quantity below interval QL / LVM 1 X below QL
r20301	BO: NOT 4 inverted output / NOT 4 inv output
r20305	BO: NOT 5 inverted output / NOT 5 inv output
r20313	BO: NCM 0 output QU / NCM 0 output QU
r20314	BO: NCM 0 output QE / NCM 0 output QE
r20315	BO: NCM 0 output QL / NCM 0 output QL
r20319	BO: NCM 1 output QU / NCM 1 output QU
r20320	BO: NCM 1 output QE / NCM 1 output QE
r20321	BO: NCM 1 output QL / NCM 1 output QL
r20325	BO: RSR 2 output Q / RSR 2 output Q
r20326	BO: RSR 2 inverted output QN / RSR 2 inv outp QN
r20330	BO: DFR 2 output Q / DFR 2 output Q
r20331	BO: DFR 2 inverted output QN / DFR 2 inv outp QN
r20336	BO: PDE 2 output Q / PDE 2 output Q
r20341	BO: PDE 3 output Q / PDE 3 output Q
r20346	BO: PDF 2 output Q / PDF 2 output Q
r20351	BO: PDF 3 output Q / PDF 3 output Q
r20356	BO: MFP 2 output Q / MFP 2 output Q
r20361	BO: MFP 3 output Q / MFP 3 output Q

2.4.4 Connector outputs (CO)

Product: G115D, Version: 4715218, Language: eng, Type: CO

r0021	CO: Actual speed smoothed / Actual speed
r0025	CO: Output voltage smoothed / Output voltage
r0026	CO: DC link voltage smoothed / DC link voltage
r0027	CO: Absolute actual current smoothed / Motor current
r0032	CO: Active power actual value smoothed / Power
r0034	CO: Motor utilization thermal / Mot_util therm

2.4 BICO parameters (connectors/binectors)

r0035	CO: Motor temperature / Mot temp
r0036	CO: Power unit overload I2t / PM overload I2t
r0037[0...19]	CO: Power unit temperatures / PM temperatures
r0039[0...2]	CO: Energy display / Energy display
r0042[0...2]	CO: Process energy display / Proc energy disp
r0060	CO: Speed setpoint before the setpoint filter / n_set before filt.
r0062	CO: Speed setpoint after the filter / n_set after filter
r0063[0...2]	CO: Actual speed / Actual speed
r0064	CO: Speed controller system deviation / n_ctrl sys dev
r0066	CO: Output frequency / f_outp
r0067	CO: Output current maximum / Current max
r0068[0...1]	CO: Absolute current actual value / I_act abs val
r0069[0...8]	CO: Phase current actual value / I_phase act val
r0070	CO: Actual DC link voltage / Vdc act val
r0072	CO: Output voltage / U_output
r0074	CO: Modulat_depth / Mod_depth
r0075	CO: Current setpoint field-generating / Id_set
r0076	CO: Current actual value field-generating / Id_act
r0077	CO: Current setpoint torque-generating / Iq_set
r0078	CO: Current actual value torque-generating / Iq_act
r0079	CO: Torque setpoint / M_set
r0080[0...1]	CO: Torque actual value / Actual torque
r0081	CO: Torque utilization / M_Utilization
r0082[0...2]	CO: Active power actual value / P_act
r0083	CO: Flux setpoint / Flux setp
r0084[0...1]	CO: Flux actual value / Actual flux
r0087	CO: Actual power factor / Cos phi act
r0094	CO: Transformation angle / Transformat_angle
r0289	CO: Maximum power unit output current / PU I_outp max
r0481[0...2]	CO: Encoder status word Gn_ZSW / Enc Gn_ZSW
r0482[0...2]	CO: Encoder actual position value Gn_XIST1 / Enc Gn_XIST1
r0752[0...1]	CO: CU analog inputs input voltage/current actual / CU AI U/I_inp act
r0755[0...1]	CO: CU analog inputs actual value in percent / CU AI value in %
r0944	CO: Counter for fault buffer changes / Fault buff change
p1001[0...n]	CO: Fixed speed setpoint 1 / n_set_fixed 1
p1002[0...n]	CO: Fixed speed setpoint 2 / n_set_fixed 2
p1003[0...n]	CO: Fixed speed setpoint 3 / n_set_fixed 3
p1004[0...n]	CO: Fixed speed setpoint 4 / n_set_fixed 4
p1005[0...n]	CO: Fixed speed setpoint 5 / n_set_fixed 5
p1006[0...n]	CO: Fixed speed setpoint 6 / n_set_fixed 6
p1007[0...n]	CO: Fixed speed setpoint 7 / n_set_fixed 7
p1008[0...n]	CO: Fixed speed setpoint 8 / n_set_fixed 8
p1009[0...n]	CO: Fixed speed setpoint 9 / n_set_fixed 9
p1010[0...n]	CO: Fixed speed setpoint 10 / n_set_fixed 10
p1011[0...n]	CO: Fixed speed setpoint 11 / n_set_fixed 11
p1012[0...n]	CO: Fixed speed setpoint 12 / n_set_fixed 12
p1013[0...n]	CO: Fixed speed setpoint 13 / n_set_fixed 13
p1014[0...n]	CO: Fixed speed setpoint 14 / n_set_fixed 14
p1015[0...n]	CO: Fixed speed setpoint 15 / n_set_fixed 15
r1024	CO: Fixed speed setpoint effective / Speed fixed setp
r1045	CO: Mot. potentiometer speed setp. in front of ramp-fct. gen. / Mop n_set bef RFG
r1050	CO: Motorized potentiometer setpoint after ramp-function generator / Mot poti setpoint
r1073	CO: Main setpoint effective / Main setpoint eff
r1077	CO: Supplementary setpoint effective / Suppl setpoint eff
r1078	CO: Total setpoint effective / Total setpoint eff

p1083[0...n]	CO: Speed limit in positive direction of rotation / n_limit pos
r1084	CO: Speed limit positive effective / n_limit pos eff
p1086[0...n]	CO: Speed limit in negative direction of rotation / n_limit neg
r1087	CO: Speed limit negative effective / n_limit neg eff
r1112	CO: Speed setpoint after minimum limiting / n_set aft min_lim
r1114	CO: Setpoint after the direction limiting / Setp after limit
r1119	CO: Ramp-function generator setpoint at the input / RFG setp at inp
r1149	CO: Ramp-function generator acceleration / RFG acceleration
r1150	CO: Ramp-function generator speed setpoint at the output / RFG n_set at outp
r1169	CO: Speed controller speed setpoints 1 and 2 / n_ctrl n_set 1/2
r1170	CO: Speed controller setpoint sum / Speed setpoint sum
r1258	CO: Vdc controller output / Vdc_ctrl output
r1298	CO: Vdc controller output (U/f) / Vdc_ctrl output
r1337	CO: Actual slip compensation / Slip comp act val
r1343	CO: I_max controller frequency output / I_max_ctrl f_outp
r1348	CO: U/f control Eco factor actual value / U/f Eco fac act v
p1351[0...n]	CO: Motor holding brake starting frequency / Brake f_start
r1438	CO: Speed controller speed setpoint / n_ctrl n_set
r1445	CO: Actual speed smoothed / n_act smooth
r1454	CO: Speed controller system deviation I component / n_ctrl sys dev Tn
r1468	CO: Speed controller P-gain effective / n_ctr Kp eff
r1482	CO: Speed controller I torque output / n_ctrl I-M_outp
r1490	CO: Droop feedback speed reduction / Droop n_reduction
r1493	CO: Moment of inertia total, scaled / M_inert tot scal
r1508	CO: Torque setpoint before supplementary torque / M_set bef. M_suppl
r1516	CO: Supplementary torque and acceleration torque / M_suppl + M_accel
r1518[0...1]	CO: Accelerating torque / M_accel
p1520[0...n]	CO: Torque limit upper / M_max upper
p1521[0...n]	CO: Torque limit lower / M_max lower
p1524[0...n]	CO: Torque limit upper scaling / M_max upper scal
p1525[0...n]	CO: Torque limit lower scaling / M_max lower scal
r1526	CO: Torque limit upper without offset / M_max up w/o offs
r1527	CO: Torque limit lower without offset / M_max low w/o offs
r1538	CO: Upper effective torque limit / M_max upper eff
r1539	CO: Lower effective torque limit / M_max lower eff
r1547[0...1]	CO: Torque limit for speed controller output / M_max outp n_ctrl
r1548[0...1]	CO: Stall current limit torque-generating maximum / Isq_max stall
p1563[0...n]	CO: Mom. of inertia estimator load torque direction of rotation pos. / J_est M pos
p1564[0...n]	CO: Mom. of inertia estimator load torque direction of rotation neg. / J_est M neg
r1568[0...5]	CO: Synchronous reluctance motor flux channel / RESM flux channel
p1570[0...n]	CO: Flux setpoint / Flux setp
r1593[0...1]	CO: Field weakening controller / flux controller output / Field/Fl_ctrl outp
r1597	CO: Field weakening controller output / Field_ctrl outp
r1598	CO: Total flux setpoint / Flux setp total
r1718	CO: Isq controller output / Isq_ctrl outp
r1723	CO: Isd controller output / Isd_ctrl outp
r1732[0...1]	CO: Direct-axis voltage setpoint / Direct U set
r1733[0...1]	CO: Quadrature-axis voltage setpoint / Quad U set
r1770	CO: Motor model speed adaptation proportional component / MotMod n_adapt Kp
r1771	CO: Motor model speed adaptation I comp. / MotMod n_adapt Tn
r1801[0...1]	CO: Pulse frequency / Pulse frequency
r1809	CO: Modulator mode actual / Modulator mode act
r2015[0...4]	CO: AS-i state / AS-i state
r2033	CO: Fieldbus interface setpoint scaling / Fieldbus setp_scal
r2050[0...11]	CO: PROFIdrive PZD receive word / PZD recv word

r2060[0...10]	CO: PROFIdrive PZD receive double word / PZD recv DW
r2089[0...4]	CO: Send binector-connector converter status word / Bin/con ZSW send
r2120	CO: Sum of fault and alarm buffer changes / Sum buffer changed
r2121	CO: Counter alarm buffer changes / Alrm buff changed
r2131	CO: Actual fault code / Act fault code
r2132	CO: Actual alarm code / Actual alarm code
r2169	CO: Actual speed smoothed signals / n_act smth message
p2201[0...n]	CO: Technology controller fixed value 1 / Tec_ctrl fix val1
p2202[0...n]	CO: Technology controller fixed value 2 / Tec_ctr fix val 2
p2203[0...n]	CO: Technology controller fixed value 3 / Tec_ctr fix val 3
p2204[0...n]	CO: Technology controller fixed value 4 / Tec_ctr fix val 4
p2205[0...n]	CO: Technology controller fixed value 5 / Tec_ctr fix val 5
p2206[0...n]	CO: Technology controller fixed value 6 / Tec_ctr fix val 6
p2207[0...n]	CO: Technology controller fixed value 7 / Tec_ctr fix val 7
p2208[0...n]	CO: Technology controller fixed value 8 / Tec_ctr fix val 8
p2209[0...n]	CO: Technology controller fixed value 9 / Tec_ctr fix val 9
p2210[0...n]	CO: Technology controller fixed value 10 / Tec_ctr fix val 10
p2211[0...n]	CO: Technology controller fixed value 11 / Tec_ctr fix val 11
p2212[0...n]	CO: Technology controller fixed value 12 / Tec_ctr fix val 12
p2213[0...n]	CO: Technology controller fixed value 13 / Tec_ctr fix val 13
p2214[0...n]	CO: Technology controller fixed value 14 / Tec_ctr fix val 14
p2215[0...n]	CO: Technology controller fixed value 15 / Tec_ctr fix val 15
r2224	CO: Technology controller fixed value effective / Tec_ctr FixVal eff
r2245	CO: Technology controller mot. potentiometer setpoint before RFG / Tec_ctr mop befRFG
r2250	CO: Technology controller motorized potentiometer setpoint after RFG / Tec_ctr mop aftRFG
r2260	CO: Technology controller setpoint after ramp-function generator / Tec_ctr set aftRFG
r2262	CO: Technology controller setpoint after filter / Tec_ctr set aftFlt
r2266	CO: Technology controller actual value after filter / Tec_ctr act aftFlt
r2272	CO: Technology controller actual value scaled / Tech_ctrl act scal
r2273	CO: Technology controller system deviation / Tec_ctrl sys_dev
p2291	CO: Technology controller maximum limiting / Tec_ctrl max_lim
p2292	CO: Technology controller minimum limiting / Tec_ctrl min_lim
r2294	CO: Technology controller output signal / Tec_ctrl outp_sig
p2295	CO: Technology controller output scaling / Tec_ctrl outp scal
r2344	CO: Technology controller last speed setpoint (smoothed) / Tec_ctrl n_setp_sm
p2900[0...n]	CO: Fixed value 1 [%] / Fixed value 1 [%]
p2901[0...n]	CO: Fixed value 2 [%] / Fixed value 2 [%]
r2902[0...14]	CO: Fixed values [%] / Fixed values [%]
p2930[0...n]	CO: Fixed value M [Nm] / Fixed value M [Nm]
r3131	CO: Actual fault value / Act fault val
r3132	CO: Actual component number / Comp_no act
r3399	CO: Setpoint active / Setpoint active
r3841	CO: Friction characteristic output / Frict outp
r5274	CO: Online tuning dynamic estimated / Ot dyn estimate
r8541	CO: Speed setpoint from the IOP in the manual mode / n_set IOP
r20095	CO: ADD 0 output Y / ADD 0 output Y
r20099	CO: ADD 1 output Y / ADD 1 output Y
r20103	CO: SUB 0 difference Y / SUB 0 difference Y
r20107	CO: SUB 1 difference Y / SUB 1 difference Y
r20111	CO: MUL 0 product Y / MUL 0 product Y
r20115	CO: MUL 1 product Y / MUL 1 product Y
r20119[0...2]	CO: DIV 0 quotient / DIV 0 quotient
r20124[0...2]	CO: DIV 1 quotient / DIV 1 quotient
r20129	CO: AVA 0 output Y / AVA 0 output Y
r20134	CO: AVA 1 output Y / AVA 1 output Y

r20220	CO: NSW 0 output Y / NSW 0 output Y
r20225	CO: NSW 1 output Y / NSW 1 output Y
r20231	CO: LIM 0 output Y / LIM 0 output Y
r20239	CO: LIM 1 output Y / LIM 1 output Y
r20247	CO: PT1 0 output Y / PT1 0 output Y
r20253	CO: PT1 1 output Y / PT1 1 output Y
r20261	CO: INT 0 output Y / INT 0 output Y
r20286	CO: DIF 0 output Y / DIF 0 output Y
r20309	CO: ADD 2 output Y / ADD 2 output Y
r20373	CO: PLI 0 output Y / PLI 0 output Y
r20379	CO: PLI 1 output Y / PLI 1 output Y

2.4.5 Connector/binector outputs (CO/BO)

Product: G115D, Version: 4715218, Language: eng, Type: CO/BO

r0046.0...31	CO/BO: Missing enable signal / Missing enable sig
r0050.0...1	CO/BO: Command Data Set CDS effective / CDS effective
r0051.0...1	CO/BO: Drive Data Set DDS effective / DDS effective
r0052.0...15	CO/BO: Status word 1 / ZSW 1
r0053.0...13	CO/BO: Status word 2 / ZSW 2
r0053.0...11	CO/BO: Status word 2 / ZSW 2
r0054.0...15	CO/BO: Control word 1 / STW 1
r0055.0...15	CO/BO: Supplementary control word / Suppl STW
r0056.0...15	CO/BO: Status word, closed-loop control / ZSW cl-loop ctrl
r0722.0...25	CO/BO: CU digital inputs status / CU DI status
r0723.0...25	CO/BO: CU digital inputs status inverted / CU DI status inv
r0835.2...8	CO/BO: Data set changeover status word / DDS_ZSW
r0836.0...1	CO/BO: Command Data Set CDS selected / CDS selected
r0837.0...1	CO/BO: Drive Data Set DDS selected / DDS selected
r0863.0...1	CO/BO: Drive coupling status word/control word / CoupleZSW/STW
r0898.0...14	CO/BO: Control word sequence control / STW seq_ctrl
r0899.0...13	CO/BO: Status word sequence control / ZSW seq_ctrl
r1099.0	CO/BO: Skip band status word / Skip band ZSW
r1198.0...15	CO/BO: Control word setpoint channel / STW setpoint chan
r1199.0...8	CO/BO: Ramp-function generator status word / RFG ZSW
r1204.0...13	CO/BO: Flying restart U/f control status / FlyRest Uf st
r1205.0...15	CO/BO: Flying restart vector control status / FlyRest vector st
r1214.0...15	CO/BO: Automatic restart status / AR status
r1239.8...13	CO/BO: DC braking status word / DCBRK ZSW
r1406.4...15	CO/BO: Control word speed controller / STW n_ctrl
r1407.0...27	CO/BO: Status word speed controller / ZSW n_ctrl
r1408.0...14	CO/BO: Status word current controller / ZSW I_ctrl
r1992.0...15	CO/BO: PolID diagnostics / PolID diag
r2129.0...15	CO/BO: Faults/alarms trigger word / F/A trigger word
r2135.12...15	CO/BO: Status word faults/alarms 2 / ZSW fault/alarm 2
r2138.7...15	CO/BO: Control word faults/alarms / STW fault/alarm
r2139.0...15	CO/BO: Status word faults/alarms 1 / ZSW fault/alarm 1
r2197.0...13	CO/BO: Status word monitoring 1 / ZSW monitor 1
r2198.0...13	CO/BO: Status word monitoring 2 / ZSW monitor 2
r2199.0...11	CO/BO: Status word monitoring 3 / ZSW monitor 3
r2225.0	CO/BO: Technology controller fixed value selection status word / Tec_ctr FixVal ZSW
r2349.0...13	CO/BO: Technology controller status word / Tec_ctrl status
r3113.0...15	CO/BO: NAMUR message bit bar / NAMUR bit bar
r3333.0...3	CO/BO: 2/3 wire control control word / 2/3 wire STW

2.4 BICO parameters (connectors/binectors)

r3396.0...16	CO/BO: Conveyor technology application status / Conveyor tech stat
r3840.0...8	CO/BO: Friction characteristic status word / Friction ZSW
r3859.1	CO/BO: Compound braking/DC quantity control status word / Comp-br/DC_ctr ZSW
r5389.0...8	CO/BO: Mot_temp status word faults/alarms / Mot_temp ZSW F/A
r5613.0...1	CO/BO: Pe energy-saving active/inactive / Pe save act/inact
r7760.0...12	CO/BO: Write protection/know-how protection status / Wr_prot/KHP stat
r8559.0...12	CO/BO: Local operator controls status / Local oper status
r9401.0...3	CO/BO: Safely remove memory card status / Mem_card rem stat
r9772.0...21	CO/BO: SI status (processor 1) / SI status P1
r9773.0...31	CO/BO: SI status (processor 1 + processor 2) / SI status P1+P2
r9872.0...21	CO/BO: SI status (processor 1) / SI status P1

2.5 Parameters for write protection and know-how protection

2.5.1 Parameters with "WRITE_NO_LOCK"

The following list contains the parameters with the "WRITE_NO_LOCK" attribute.

These parameters are not affected by the write protection.

Product: G115D, Version: 4715218, Language: eng, Type: WRITE_NO_LOCK

p0003	Access level / Acc_level
p0010	Drive commissioning parameter filter / Drv comm. par_filt
p0124[0...n]	CU detection via LED / CU detection LED
p0970	Reset drive parameters / Drive par reset
p0971	Save parameters / Save par
p0972	Drive unit reset / Drv_unit reset
p2111	Alarm counter / Alarm counter
p3950	Service parameter / Serv par
p3981	Acknowledge drive object faults / Ackn DO faults
p3985	Master control mode selection / PcCtrl mode select
p7761	Write protection / Write protection
p8805	Identification and maintenance 4 configuration / I&M 4 config
p8806[0...53]	Identification and Maintenance 1 / I&M 1
p8807[0...15]	Identification and Maintenance 2 / I&M 2
p8808[0...53]	Identification and Maintenance 3 / I&M 3
p8809[0...53]	Identification and Maintenance 4 / I&M 4
p9400	Safely remove memory card / Mem_card rem
p9484	BICO interconnections search signal source / BICO s_s srch

2.5.2 Parameters with "KHP_WRITE_NO_LOCK"

The following list contains the parameters with the "KHP_WRITE_NO_LOCK" attribute.

These parameters are not affected by the know-how protection.

Product: G115D, Version: 4715218, Language: eng, Type: KHP_WRITE_NO_LOCK

p0003	Access level / Acc_level
p0010	Drive commissioning parameter filter / Drv comm. par_filt
p0124[0...n]	CU detection via LED / CU detection LED
p0970	Reset drive parameters / Drive par reset
p0971	Save parameters / Save par
p0972	Drive unit reset / Drv_unit reset
p2040	Fieldbus interface monitoring time / Fieldbus t_monit
p2111	Alarm counter / Alarm counter
p3950	Service parameter / Serv par
p3981	Acknowledge drive object faults / Ackn DO faults
p3985	Master control mode selection / PcCtrl mode select
p7761	Write protection / Write protection
p8805	Identification and maintenance 4 configuration / I&M 4 config
p8806[0...53]	Identification and Maintenance 1 / I&M 1
p8807[0...15]	Identification and Maintenance 2 / I&M 2
p8808[0...53]	Identification and Maintenance 3 / I&M 3
p8809[0...53]	Identification and Maintenance 4 / I&M 4
p8980	Ethernet/IP profile / Eth/IP profile
p8981	Ethernet/IP ODVA STOP mode / Eth/IP ODVA STOP

p8982	Ethernet/IP ODVA speed scaling / Eth/IP ODVA n scal
p8983	Ethernet/IP ODVA torque scaling / Eth/IP ODVA M scal
p9400	Safely remove memory card / Mem_card rem
p9484	BICO interconnections search signal source / BICO s_s srch

2.5.3 Parameters with "KHP_ACTIVE_READ"

The following list contains the parameters with the "KHP_ACTIVE_READ" attribute.

These parameters can also be read with activated know-how protection.

Product: G115D, Version: 4715218, Language: eng, Type: KHP_ACTIVE_READ

p0015	Macro drive unit / Macro drv unit
p0100	IEC/NEMA Standards / IEC/NEMA Standards
p0170	Number of Command Data Sets (CDS) / CDS count
p0180	Number of Drive Data Sets (DDS) / DDS count
p0300[0...n]	Motor type selection / Mot type sel
p0304[0...n]	Rated motor voltage / Mot U_rated
p0305[0...n]	Rated motor current / Mot I_rated
p0400[0...n]	Encoder type selection / Enc_typ sel
p0505	Selecting the system of units / Unit sys select
p0595	Technological unit selection / Tech unit select
p0806	BI: Inhibit master control / PcCtrl inhibit
p0870	BI: Close main contactor / Close main cont
p0922	PROFIdrive PZD telegram selection / PZD telegr_sel
p1080[0...n]	Minimum speed / n_min
p1082[0...n]	Maximum speed / n_max
p1520[0...n]	CO: Torque limit upper / M_max upper
p2000	Reference speed reference frequency / n_ref f_ref
p2001	Reference voltage / Reference voltage
p2002	Reference current / I_ref
p2003	Reference torque / M_ref
p2005	Reference angle / Reference angle
p2006	Reference temperature / Ref temp
p2007	Reference acceleration / a_ref
p2030	Field bus interface protocol selection / Field bus protocol
p2038	PROFIdrive STW/ZSW interface mode / PD STW/ZSW IF mode
p2079	PROFIdrive PZD telegram selection extended / PZD telegr ext
p7763	KHP OEM exception list number of indices for p7764 / KHP OEM qty p7764
p7764[0...n]	KHP OEM exception list / KHP OEM excep list
p9601	SI enable functions integrated in the drive (processor 1) / SI enable fct P1
p9810	SI PROFIsafe address (processor 2) / SI PROFIsafe P2

2.6 Quick commissioning (p0010 = 1)

The parameters required for the quick commissioning (p0010 = 1) are shown in the following table:

Table 2-7 Quick commissioning (p0010 = 1)

Par. no.	Name	Access level	Can be changed
p0010	Drive, commissioning parameter filter	1	C(1)T
p0015	Macro drive unit	1	C,C(1)
p0100	IEC/NEMA mot stds	1	C(1)
p0205	Power unit application	1	C(1,2)
p0230	Drive filter type, motor side	1	C(1,2)
p0300	Motor type selection	2	C(1,3)
p0301	Motor code number selection	2	C(1,3)
p0304	Rated motor voltage	1	C(1,3)
p0305	Rated motor current	1	C(1,3)
p0306	Number of motors connected in parallel	1	C(1,3)
p0307	Rated motor power	1	C(1,3)
p0308	Rated motor power factor	1	C(1,3)
p0309	Rated motor efficiency	1	C(1,3)
p0310	Rated motor frequency	1	C(1,3)
p0311	Rated motor speed	1	C(1,3)
p0314	Motor pole pair number	3	C(1,3)
p0316	Motor torque constant	3	C(1,3)UT
p0322	Maximum motor speed	1	C(1,3)
p0323	Maximum motor current	1	C(1,3)
p0335	Motor cooling type	2	C(1,3)T
p0400	Encoder type selection	1	C(1,4)
p0402	Gear unit type selection	1	C(1,4)
p0500	Technology application	2	C(1,5)T
p0640	Current limit	2	C(1,3)UT
p0922	PROFIdrive telegram selection	1	C(1)T
p0970	Reset drive parameters	1	C(1,30)
p1080	Minimum speed	1	C(1)T
p1082	Maximum rotation speed	1	C(1)T
p1120	Ramp-function generator ramp-up time	1	C(1)UT
p1121	Ramp-function generator ramp-down time	1	C(1)UT
p1135	OFF3 ramp-down time	2	C(1)UT
p1300	Open-loop/closed-loop control operating mode	2	C(1)T

Table 2-7 Quick commissioning (p0010 = 1), continued

Par. no.	Name	Access level		Can be changed
p1500	Torque setpoint selection	2		C(1)T
p1900	Motor data identification and rotating measurement	1		C(1)T
p1905	Parameter tuning selection	1		C(1)T
p2196	Torque utilization scaling	1		C(1,3)UT
p3900	Completion of quick commissioning	1		C(1)

If p0010 = 1 is selected, p0003 (user access level) can be used to select the parameters that are to be accessed.

At the end of the quick commissioning, set p3900 = 1 to perform the required motor calculations and reset all other parameters (not included in p0010 = 1) to their default settings.

Note

This only applies for the quick commissioning.

Function diagrams

Content

3.1	Table of contents	492
3.2	Explanations of the function diagrams	498
3.3	Input/output terminals, DIP switch	503
3.4	PROFenergy	511
3.5	Communication PROFIdrive (PROFINET), EtherNet/IP	514
3.6	Communication, fieldbus interface (AS-Interface)	534
3.7	Internal control/status words	541
3.8	Brake control	561
3.9	Safety Integrated Basic Functions	563
3.10	Safety Integrated PROFIsafe	569
3.11	Setpoint channel	572
3.12	Encoder evaluation	583
3.13	Vector control / U/f control	585
3.14	Technology functions	616
3.15	Conveyor technology applications	619
3.16	Free function blocks	632
3.17	Technology controller	653
3.18	Signals and monitoring functions	658
3.19	Diagnostics	671
3.20	Data sets	677

3.1 Table of contents

3.2 Explanations of the function diagrams	498
1020 – Explanation of the symbols (part 1)	499
1021 – Explanation of the symbols (part 2)	500
1022 – Explanation of the symbols (part 3)	501
1030 – Handling BICO technology	502
3.3 Input/output terminals, DIP switch	503
2201 – Connection overview	504
2220 – Digital inputs, electrically isolated (DI 0 ... DI 3)	505
2230 – Digital inputs/outputs bidirectional (DI/DO 24 ... DI/DO 25)	506
2251 – Motor speed potentiometers 1 and 2	507
2272 – Two-wire control	508
2273 – Three-wire control	509
2280 – Quick commissioning using DIP switch	510
3.4 PROFIenergy	511
2381 – Control commands and interrogation commands	512
2382 – States	513
3.5 Communication PROFIdrive (PROFINET), EtherNet/IP	514
2401 – Overview	515
2410 – PROFIdrive, EtherNet/IP - addresses and diagnostics	516
2420 – PROFIdrive - telegrams and process data (PZD)	517
2440 – PROFIdrive - PZD receive signals interconnection	518
2441 – PROFIdrive - STW1 control word interconnection (p2038 = 2)	519
2442 – PROFIdrive - STW1 control word interconnection (p2038 = 0)	520
2444 – PROFIdrive - STW2 control word interconnection (p2038 = 0)	521
2446 – PROFIdrive - STW3 control word interconnection	522
2448 – PROFIdrive - STW_G115D control word interconnection	523
2450 – PROFIdrive - PZD send signals interconnection	524
2451 – PROFIdrive - ZSW1 status word interconnection (p2038 = 2)	525
2452 – PROFIdrive - ZSW1 status word interconnection (p2038 = 0)	526
2454 – PROFIdrive - ZSW2 status word interconnection (p2038 = 0)	527
2456 – PROFIdrive - ZSW3 status word interconnection	528
2458 – PROFIdrive - ZSW_G115D status word interconnection	529
2468 – PROFIdrive - receive telegram, free interconnection via BICO (p0922 = 999)	530

2470 – PROFIdrive - send telegram, free interconnection via BICO (p0922 = 999)	531
2472 – PROFIdrive - status words, free interconnection	532
2473 – EtherNet/IP - control word / status word interconnection	533
3.6 Communication, fieldbus interface (AS-Interface)	534
9430 – Configuration, addresses and diagnostics	535
9431 – Interconnection overview	536
9435 – STW1 control word interconnection (p0015 = 30/31/34)	537
9438 – STW3 control word interconnection	538
9445 – ZSW1 status word interconnection	539
9455 – Fixed speed setpoints (p0015 = 30/31, p1016 = 2)	540
3.7 Internal control/status words	541
2501 – Control word sequence control (r0898)	542
2503 – Status word sequence control (r0899)	543
2505 – Control word setpoint channel (r1198)	544
2507 – status word key status (r8559)	545
2510 – Status word 1 (r0052)	546
2511 – Status word 2 (r0053)	547
2512 – Control word 1 (r0054)	548
2513 – Supplementary control word (r0055)	549
2520 – Control word speed controller (r1406)	550
2522 – Status word speed controller (r1407)	551
2526 – Status word closed-loop control (r0056)	552
2530 – Status word current control (r1408)	553
2534 – Status word monitoring functions 1 (r2197)	554
2536 – Status word monitoring functions 2 (r2198)	555
2537 – Status word monitoring functions 3 (r2199)	556
2546 – Control word faults/alarms (r2138)	557
2548 – Status word faults/alarms 1 and 2 (r2139 and r2135)	558
2610 – Sequence control - Sequencer	559
2634 – Sequence control - missing enable signals, line contactor control	560
3.8 Brake control	561
2701 – Basic brake control	562
3.9 Safety Integrated Basic Functions	563
2800 – Parameter manager	564

2802 – Monitoring functions and faults/alarms	565
2804 – Status words	566
2810 – STO (Safe Torque Off)	567
2813 – F-DI (Fail-safe Digital Input)	568
3.10 Safety Integrated PROFIsafe	569
2915 – Standard telegrams	570
2917 – Manufacturer-specific telegrams	571
3.11 Setpoint channel	572
3001 – Overview	573
3010 – Fixed speed setpoints, binary selection (p1016 = 2)	574
3011 – Fixed speed setpoints, direct selection (p1016 = 1)	575
3020 – Motorized potentiometer	576
3030 – Main/supplementary setpoint, setpoint scaling, jogging	577
3040 – Direction limitation and direction reversal	578
3050 – Skip frequency bands and speed limitations	579
3060 – Basic ramp-function generator	580
3070 – Extended ramp-function generator	581
3080 – Ramp-function generator selection, status word, tracking	582
3.12 Encoder evaluation	583
4704 – Position sensing encoder 1	584
3.13 Vector control / U/f control	585
6020 – Speed control and generation of the torque limits, overview	587
6030 – Speed setpoint, droop	588
6031 – Precontrol symmetrization, acceleration model	589
6035 – Moment of inertia estimator	590
6040 – Speed controller	591
6050 – Kp_n-/Tn_n adaptation	592
6060 – Torque setpoint	593
6220 – Vdc_max controller and Vdc_min controller	594
6300 – U/f control, overview	595
6301 – U/f control, characteristic and voltage boost	596
6310 – U/f control, resonance damping and slip compensation	597
6320 – U/f control, Vdc_max controller	598
6490 – Speed control configuration	599

6491 – Flux control configuration	600
6630 – Upper/lower torque limit	601
6640 – Current/power/torque limits	602
6700 – Current control, overview	603
6710 – Current setpoint filter	604
6714 – Iq and Id controllers	605
6721 – Id setpoint (PMSM, p0300 = 2xx)	606
6722 – Field weakening characteristic, flux setpoint (ASM, p0300 = 1)	607
6723 – Field weakening controller, flux controller, Id setpoint (ASM, p0300 = 1)	608
6724 – Field weakening controller (PMSM, p0300 = 2xx)	609
6730 – Interface to the Power Module (ASM, p0300 = 1xx)	610
6731 – Interface to the Power Module (PMSM, p0300 = 2xx)	611
6790 – Flux setpoint (RESM, p0300 = 6xx)	612
6791 – Id setpoint (RESM, p0300 = 6xx)	613
6792 – Interface to the Power Module (RESM, p0300 = 6xx)	614
6799 – Display signals	615
3.14 Technology functions	616
7010 – Friction characteristic	617
7017 – DC braking (ASM, p0300 = 1)	618
3.15 Conveyor technology applications	619
7040 – Conveyor, 1 Direction / 1 Speed (p3393 = 1)	620
7041 – Conveyor, 1 Direction / 2 Speeds (p3393 = 2)	621
7042 – Conveyor, 2 Directions / 1 Speed (p3393 = 3)	622
7043 – Conveyor, 2 Directions / 2 Speeds (p3393 = 4)	623
7044 – Turntable, 2 Positions / 1 Speed (p3393 = 5)	624
7045 – Turntable, 2 Positions / 2 Speeds (p3393 = 6)	625
7046 – Turntable, 3 Positions / 1 Speed (p3393 = 7)	626
7047 – Turntable, 3 Positions / 2 Speeds (p3393 = 8)	627
7048 – Corner turntable lift, 2 Positions / 1 Speed (p3393 = 9)	628
7049 – Corner turntable lift, 2 Positions / 2 Speeds (p3393 = 10)	629
7050 – Travelling Trolley, 1 Speed (p3393 = 11)	630
7051 – Travelling Trolley, 2 Speeds (p3393 = 12)	631
3.16 Free function blocks	632
7200 – Sampling times of the runtime groups	633
7210 – AND 0 ... 3	634

7212 – OR 0 ... 3	635
7214 – XOR 0 ... 3	636
7216 – NOT 0 ... 5	637
7220 – ADD 0 ... 2, SUB 0 ... 1	638
7222 – MUL 0 ... 1, DIV 0 ... 1	639
7224 – AVA 0 ... 1	640
7225 – NCM 0 ... 1	641
7226 – PLI 0 ... 1	642
7230 – MFP 0 ... 3, PCL 0 ... 1	643
7232 – PDE 0 ... 3	644
7233 – PDF 0 ... 3	645
7234 – PST 0 ... 1	646
7240 – RSR 0 ... 2, DFR 0 ... 2	647
7250 – BSW 0 ... 1, NSW 0 ... 1	648
7260 – LIM 0 ... 1	649
7262 – PT1 0 ... 1	650
7264 – INT 0, DIF 0	651
7270 – LVM 0 ... 1	652
3.17 Technology controller	653
7950 – Fixed values, binary selection (p2216 = 2)	654
7951 – Fixed values, direct selection (p2216 = 1)	655
7954 – Motorized potentiometer	656
7958 – Closed-loop control	657
3.18 Signals and monitoring functions	658
8005 – Overview	659
8010 – Speed signals 1	660
8011 – Speed signals 2	661
8012 – Torque signals, motor blocked/stalled	662
8013 – Load monitoring (Part 1)	663
8014 – Load monitoring (Part 2)	664
8016 – Thermal monitoring motor, motor temperature status word faults/alarms	665
8017 – Motor temperature model 1 (I2t)	666
8018 – Motor temperature model 2	667
8021 – Thermal monitoring, power unit	668
8022 – Monitoring functions 1	669
8023 – Monitoring functions 2	670

3.19 Diagnostics	671
8050 – Overview	672
8060 – Fault buffer	673
8065 – Alarm buffer	674
8070 – Faults/alarms trigger word (r2129)	675
8075 – Faults/alarms configuration	676
3.20 Data sets	677
8560 – Command Data Sets (CDS)	678
8565 – Drive Data Sets (DDS)	679

3.2 Explanations of the function diagrams

Function diagrams

1020 – Explanation of the symbols (part 1)	499
1021 – Explanation of the symbols (part 2)	500
1022 – Explanation of the symbols (part 3)	501
1030 – Handling BICO technology	502

Fig. 3-1 1020 – Explanation of the symbols (part 1)

Parameters		Connectors		Binectors		Connectors/binectors	
Symbol Parameter name [Unit] rxxx[y..z] ↑	Meaning Monitoring parameter with unit [Unit] and index range [y..z] or data set [C/D]	Symbol Parameter name pxxx[y..z] ↳ (Def)	Meaning Connector input CI with index range [y..z] or data set [C/D] and factory setting (Def) *	Symbol Parameter name pxxx[y..z] ↳ (Def.y)	Meaning Binector input BI with index range [y..z] or data set [C/D] and factory setting.bit number (Def)	Symbol Parameter name rxxx ↳	Meaning Connector/binector output CO/BO
Symbol Parameter name from ... to [Unit] pxxx[C/D] (Def) ↓	Meaning Setting parameter with min/max value and unit [Unit] data set [C/D] and factory setting (Def) *	Symbol Parameter name [Unit] rxxx[y..z] →	Meaning Connector output CO with unit [Unit] and with index range [y..z]	Symbol Parameter name rxxx	Meaning Binector output BO	Pre-assigned connectors	
		CI: Connector Input CO: Connector Output CO/BO: Connector/Binector Output		BI: Binector Input BO: Binector Output		Symbol Parameter name from ... to [Unit] pxxx[D] (Def) ↓	Meaning Setting parameter with min/max value and unit [Unit] data set [D] and factory setting (Def)
Data sets		Information on parameters, binectors, connectors				Cross references between diagrams	
Symbol pxxx[C] ↓	Meaning Parameter belongs to the Command Data Set (CDS).	Symbol Parameter name [Unit]	Meaning Parameter name (up to 18 characters) [dimension unit]			Symbol Signal path Text → [aaaa.b]	Meaning The function diagrams are sub-divided into signal paths 1...8 in order to facilitate orientation. Text = Unique signal designation aaaa = Signal to target diagram aaaa b = Signal to signal path b
Symbol pxxx[D] ↓	Meaning Parameter belongs to the Drive Data Set (DDS).	rxxx[y] or rxxx[y..z] or rxxx[y].ww or rxxx.ww	"r" = monitoring parameter. These parameters are read-only "xxxx" stands for the parameter number "[y]" specifies the applicable index, "[y..z]" specifies the index range ".ww" specifies the bit number (e.g. 0...15).			[cccc.d] → Text	Text = Unique signal designation cccc = Signal from source diagram cccc d = Signal from signal path d
Symbol pxxx[E] ↓	Meaning Parameter belongs to the Encoder Data Set (EDS).	pxxx[y] or pxxx[y..z] or pxxx[y].ww or pxxx.ww	"p" = setting parameter. These parameters can be changed. "xxxx" stands for the parameter number, "[y]" specifies the applicable index, "[y..z]" specifies the index range ".ww" specifies the bit number (e.g. 0...15).			To "function diagram name" [aaaa.b] = binectors.	
Symbol pxxx[M] ↓	Meaning Parameter belongs to the Motor Data Set (MDS).	from ... to	Value range.			Cross references for control bits	
Symbol pxxx[P] ↓	Meaning Parameter belongs to the Power unit Data Set (PDS).	(xxx[y].ww)	Parameter number (xxxx) with Index number [y] and bit number .ww.			Symbol pxxx [aaaa.b]	Meaning pxxx= Original parameter of signal aaaa = Signal from source diagram aaaa b = Signal from signal path b
		(Def)	Factory setting.				
		(Def.w)	Factory setting with bit number as prefix.				
		[aaaa.b]	Diagram references for setting parameters that occur a multiple number of times. [Function diagram number, signal path]				
*) For some parameters the value for the factory setting is calculated during commissioning for they are dependent on Power Module and motor (see Section 2.1.1 "Calculated").							
1	2	3	4	5	6	7	8
Explanations on the function diagrams					fp_1020_97_61.vsd	Function diagram	
Explanation of the symbols (part 1)					20.07.2021 V4.7_13	G115D	
							- 1020 -

<p>Pre-assigned connectors</p> <p>Fixed percentage values</p> <p>Fixed value 1 [%] -10000.00 ... 10000.00 [%] p2900 [D] (120.00)</p> <p>or</p> <p>Fixed value 1 [%] -10 000.00 ... 10 000.00 [%] p2900[D] (0.00)</p> <p>Fixed value 2 [%] -10 000.00 ... 10 000.00 [%] p2901[D] (0.00)</p> <p>Fixed values [%] p2902[0...14] (0.00)</p> <p>p2902[0] = +0 % p2902[5] = +100 % p2902[10] = -20 % p2902[1] = +5 % p2902[6] = +150 % p2902[11] = -50 % p2902[2] = +10 % p2902[7] = +200 % p2902[12] = -100 % p2902[3] = +20 % p2902[8] = -5 % p2902[13] = -150 % p2902[4] = +50 % p2902[9] = -10 % p2902[14] = -200 %</p>	<p>Symbols for logic functions</p> <p>NOT element Logical inversion (negation)</p> <p>AND element with logical inversion of an input</p> <p>OR element</p> <p>Exclusive-OR/XOR $y = 1$ when $x_1 \neq x_2$ is.</p> <p>Comparator $y = 1$ when $x_1 = x_2$ is.</p> <p>R/S flip-flop S = setting input R = reset input Q = non-inverted output \bar{Q} = inverted output</p>	<p>Symbols for computational and closed-loop control functions</p> <p>Threshold value switch 1/0 Outputs at y a logical "1" if $x < S$.</p> <p>Threshold value switch 0/1 Outputs at y a logical "1" if $x > S$.</p> <p>Threshold value 1/0 with hysteresis Outputs a logical "1" at y if $x < S$. If $x \geq S + H$ then y returns to 0.</p> <p>Threshold value 0/1 with hysteresis Outputs a logical "1" at y if $x > S$. If $x \leq S - H$ then y returns to 0.</p> <p>Limiter x is limited to the upper limit LU and the lower limit LL and output at y. The digital signals MLU and MLL have the value "1", if the upper or lower limit is active.</p> <p>Sample & Hold element Sample and hold element. $y = x$ if SET = 1 (not retentively saved at POWER OFF)</p>		
<p>Fixed speed values</p> <p>n_set_fixed 1 -210000.000 ... 210000.000 [rpm] p1001 [D] (0.000)</p> <p>or</p> <p>n_set_fixed 1 -210 000.000 ... 210 000.000 [rpm] p1001[D] (0.000)</p> <p>n_set_fixed 15 -210 000.000 ... 210 000.000 [rpm] p1015[D] (0.000)</p>	<p>Symbols for computational and closed-loop control functions</p> <p>Sign reversal $y = -x$</p> <p>Absolute value generator $y = x$</p> <p>Divider $y = \frac{x_1}{x_2}$</p> <p>Multiplier $y = x_1 \cdot x_2$</p> <p>Comparator greater than 0 Output y = a logical "1", if the analog signal $x > 0$, i.e. is positive.</p> <p>Differentiator $y = \frac{dx}{dt}$</p>	<p>Limiter</p> <p>Sample & Hold element</p>		
<p>Fixed torque value</p> <p>Fixed value M [Nm] -100000.00 ... 100000.00 [Nm] p2930 [D] (0.00)</p> <p>or</p> <p>Fixed value M [Nm] -100 000.00 ... 100 000.00 [Nm] p2930[D] (0.00)</p>	<p>Symbol for monitoring</p> <p>Monitoring → Axxxxx or Fxxxxx</p> <p>Monitoring In the bottom right-hand corner of the diagram.</p>	<p>Limiter</p> <p>Sample & Hold element</p>		
<p>1</p>	<p>2</p>	<p>3</p>		
<p>4</p>	<p>5</p>	<p>6</p>		
<p>7</p>	<p>8</p>	<p>9</p>		
<p>Explanations on the function diagrams</p>		<p>fp_1021_97_61.vsd</p>	<p>Function diagram</p>	<p>- 1021 -</p>
<p>Explanation of the symbols (part 2)</p>		<p>20.07.2021 V4.7_13</p>	<p>G115D</p>	<p>- 1021 -</p>

Fig. 3-2

1021 – Explanation of the symbols (part 2)

Fig. 3-3 1022 – Explanation of the symbols (part 3)

<p>Switch-on delay</p> <p>The digital signal x must have the value "1" without any interruption during the time T before output y changes to "1".</p>	<p>Switch symbol</p> <p>Simple changeover switch The switch position is shown according to the factory setting of pxxxx (in this case switch position 1).</p>	<p>2nd-order filter (bandstop/general filter)</p> <p>Natural frequency, numerator: f_{n_n}, pzzzz Damping, numerator: D_n, pwwwww Natural frequency, denominator: f_{n_d}, pxxxx Damping, denominator: D_d, pyyyy</p> <p>Used as bandstop filter</p> <ul style="list-style-type: none"> - center frequency f_s: $f_{n_n} = f_s$, $f_{n_d} = f_s$ - bandwidth f_B: $D_n = 0$, $D_d = \frac{f_B}{2 \cdot f_s}$ <p>Transfer function when used as general filter</p> $H(s) = \frac{\left(\frac{s}{2\pi f_{n_n}}\right)^2 + \frac{2 \cdot D_n}{2\pi f_{n_n}} \cdot s + 1}{\left(\frac{s}{2\pi f_{n_d}}\right)^2 + \frac{2 \cdot D_d}{2\pi f_{n_d}} \cdot s + 1}$			
<p>Switch-off delay</p> <p>The digital signal x must have the value "0" without interruption during the time T before output y changes to "0".</p>	<p>PT1 element</p> <p>Delay element, first order. pxxxx = time constant</p>	<p>PT2 low pass</p> <p>Natural frequency, denominator: f_{n_d}, pxxxx Damping, denominator: D_d, pyyyy</p> <p>Transfer function</p> $H(s) = \frac{1}{\left(\frac{s}{2\pi f_{n_d}}\right)^2 + \frac{2 \cdot D_d}{2\pi f_{n_d}} \cdot s + 1}$			
<p>Delay (switch-on and switch-off)</p> <p>The digital signal x must have the value "1" without interruption during time T1 or must have the value "0" during time T2 before output y changes its signal state.</p>	<p>Analog adder can be activated</p> <p>The following applies to I = 1 signal: $y = x_1 + x_2$ The following applies to I = 0 signal: $y = x_1$</p>				
<p>1 2 3 4 5</p>	<p>6 7 8</p>				
<p>Explanations on the function diagrams</p>			<p>fp_1022_97_61.vsd</p>	<p>Function diagram</p>	<p>- 1022 -</p>
<p>Explanation of the symbols (part 3)</p>			<p>20.07.2021 V4.7_13</p>	<p>G115D</p>	<p></p>

Handling BICO technology

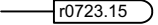
Binector:  r0723.15 Binectors are binary signals that can be freely interconnected (BO = Binector Output). They represent a bit of a "BO:" display parameter (e.g. bit 15 from r0723).

Connector:  r0723 Connectors are "analog signals" that can be freely interconnected (e.g. percentage variables, speeds or torques). Connectors are also "CO:" display parameters (CO = Connector Output).

Parameterization:

At the signal destination, the required binector or connector is selected using appropriate parameters:
 "BI:" parameter for binectors (BI = Binector Input)
 or
 "CI:" parameter for connectors (CI = Connector Input)

Example:

The main setpoint for the speed controller (CI: p1070) should be received from the output of the motorized potentiometer (CO: r1050) and the "jog" command (BI: p1055) from Digital Input DI 0 (BO: r0722.0, Terminal 5 (KI. 5)) on the CU.

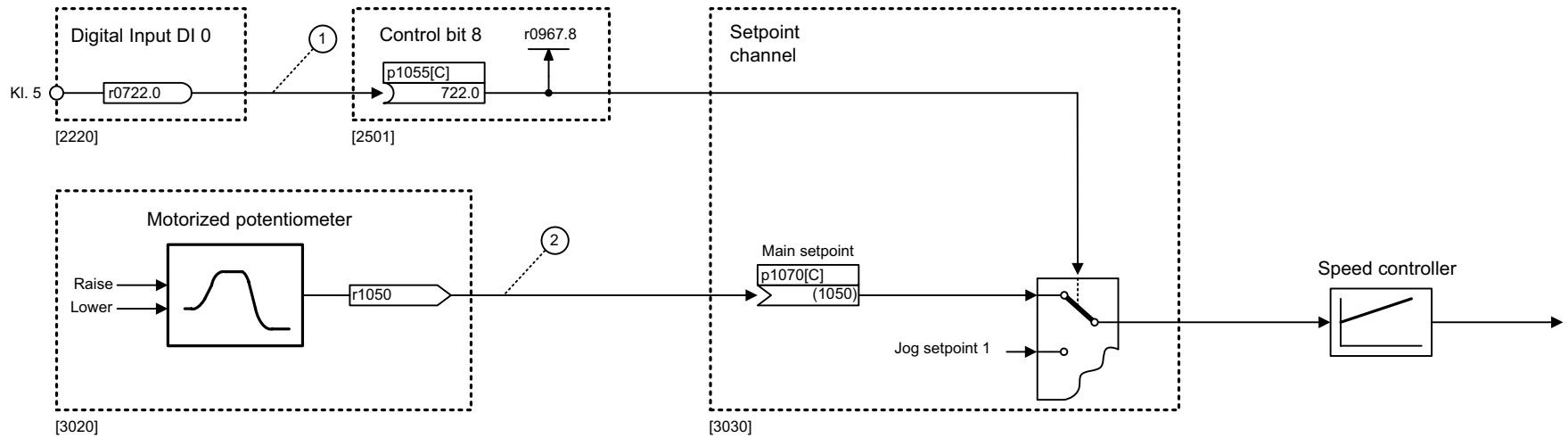

Parameterizing steps:

- ① p1055[0] = 722.0 Terminal 5 (KI. 5) acts as "Jog bit 0".
- ② p1070[0] = 1050 The output of the motorized potentiometer acts as main setpoint for the speed controller.

1	2	3	4	5	6	7	8
Explanations on the function diagrams					fp_1030_97_61.vsd	Function diagram	
Handling BICO technology					20.07.2021 V4.7_13	G115D	
- 1030 -							

3.3 Input/output terminals, DIP switch

Function diagrams

2201 – Connection overview	504
2220 – Digital inputs, electrically isolated (DI 0 ... DI 3)	505
2230 – Digital inputs/outputs bidirectional (DI/DO 24 ... DI/DO 25)	506
2251 – Motor speed potentiometers 1 and 2	507
2272 – Two-wire control	508
2273 – Three-wire control	509
2280 – Quick commissioning using DIP switch	510

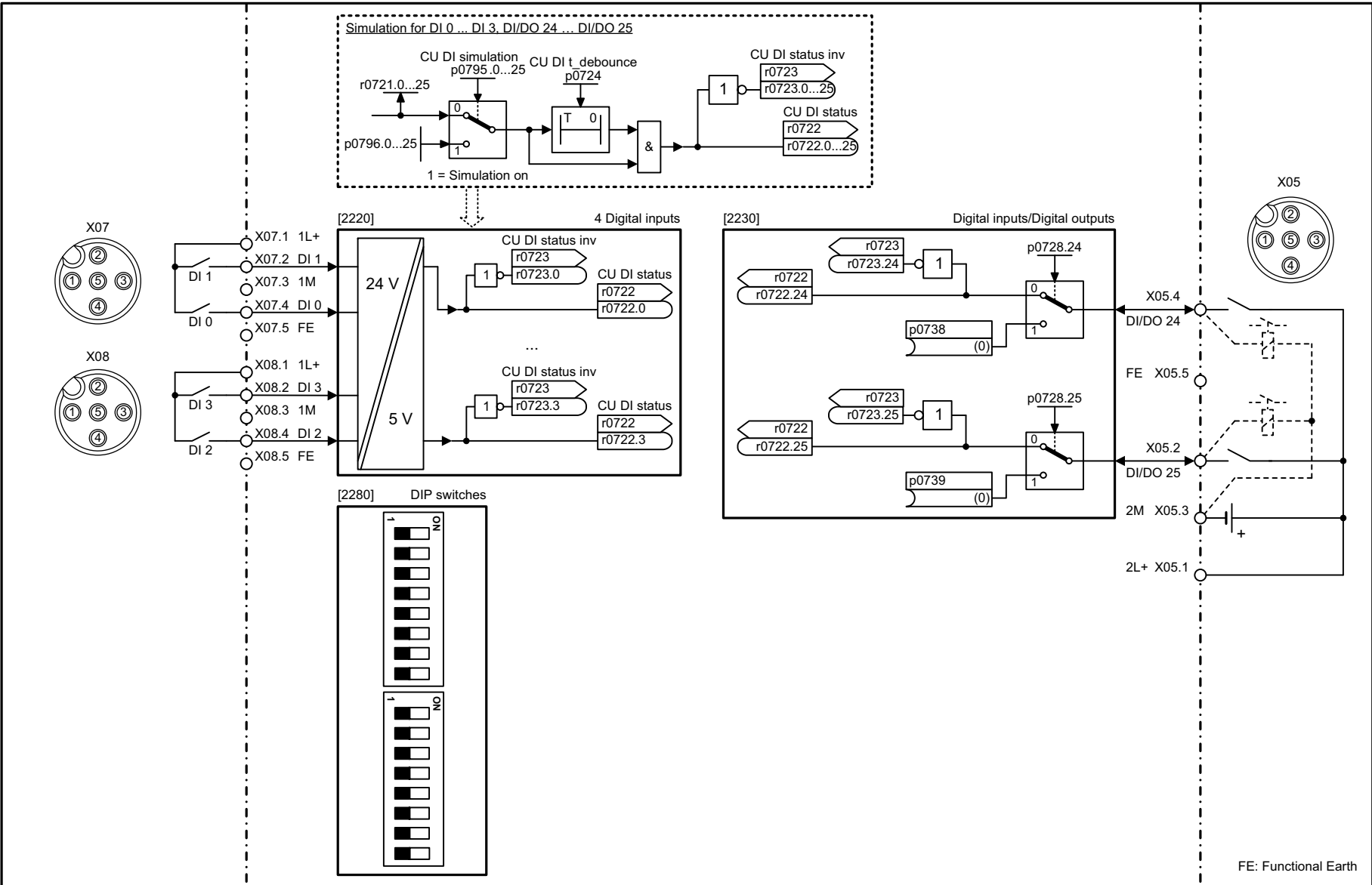
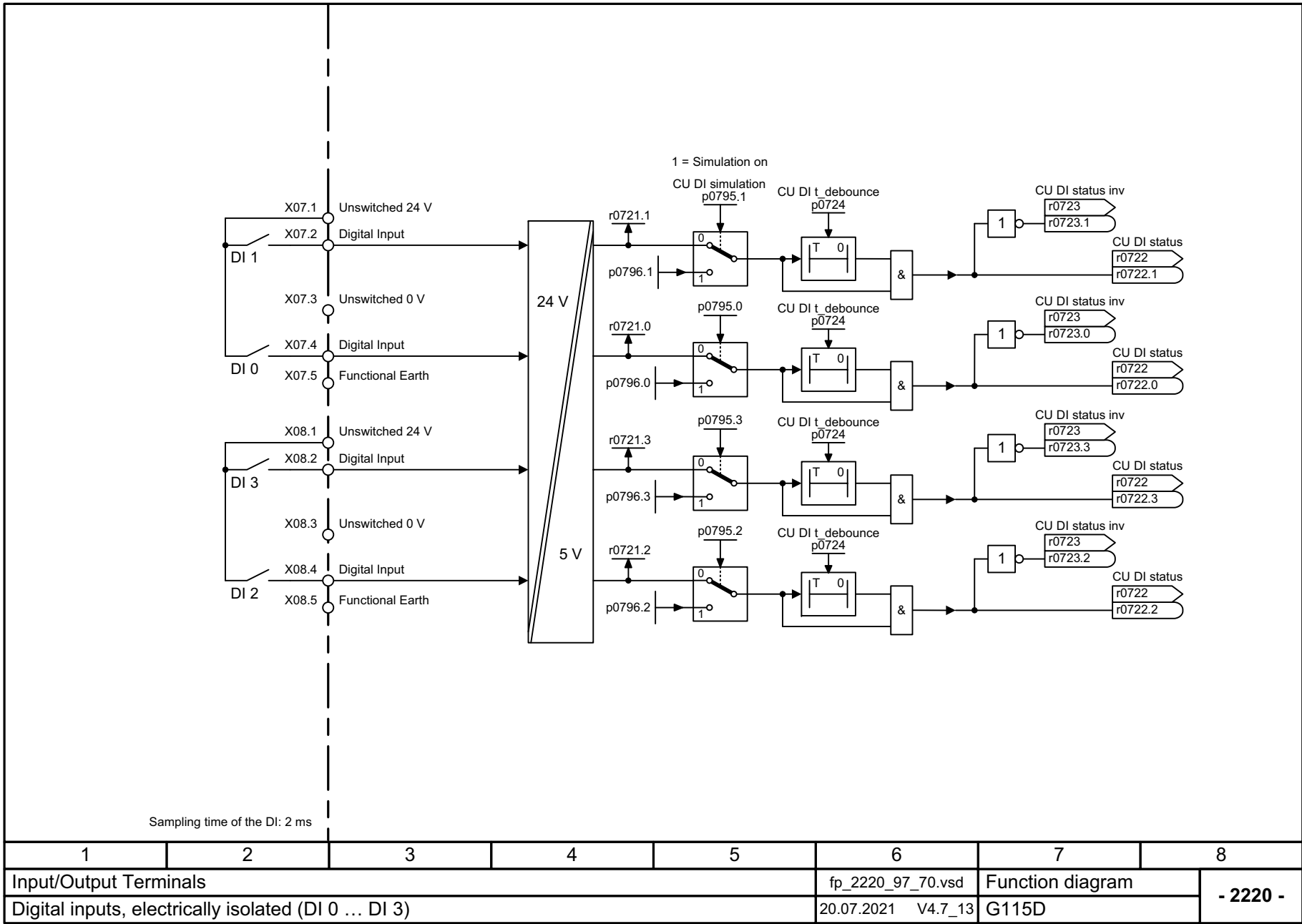

Fig. 3-5 2201 – Connection overview

1	2	3	4	5	6	7	8
Input/Output Terminals					fp_2201_97_08.vsd	Function diagram	
Connection overview					20.07.2021 V4.7_13	G115D	
							- 2201 -

Fig. 3-6 2220 – Digital inputs, electrically isolated (DI 0 ... DI 3)



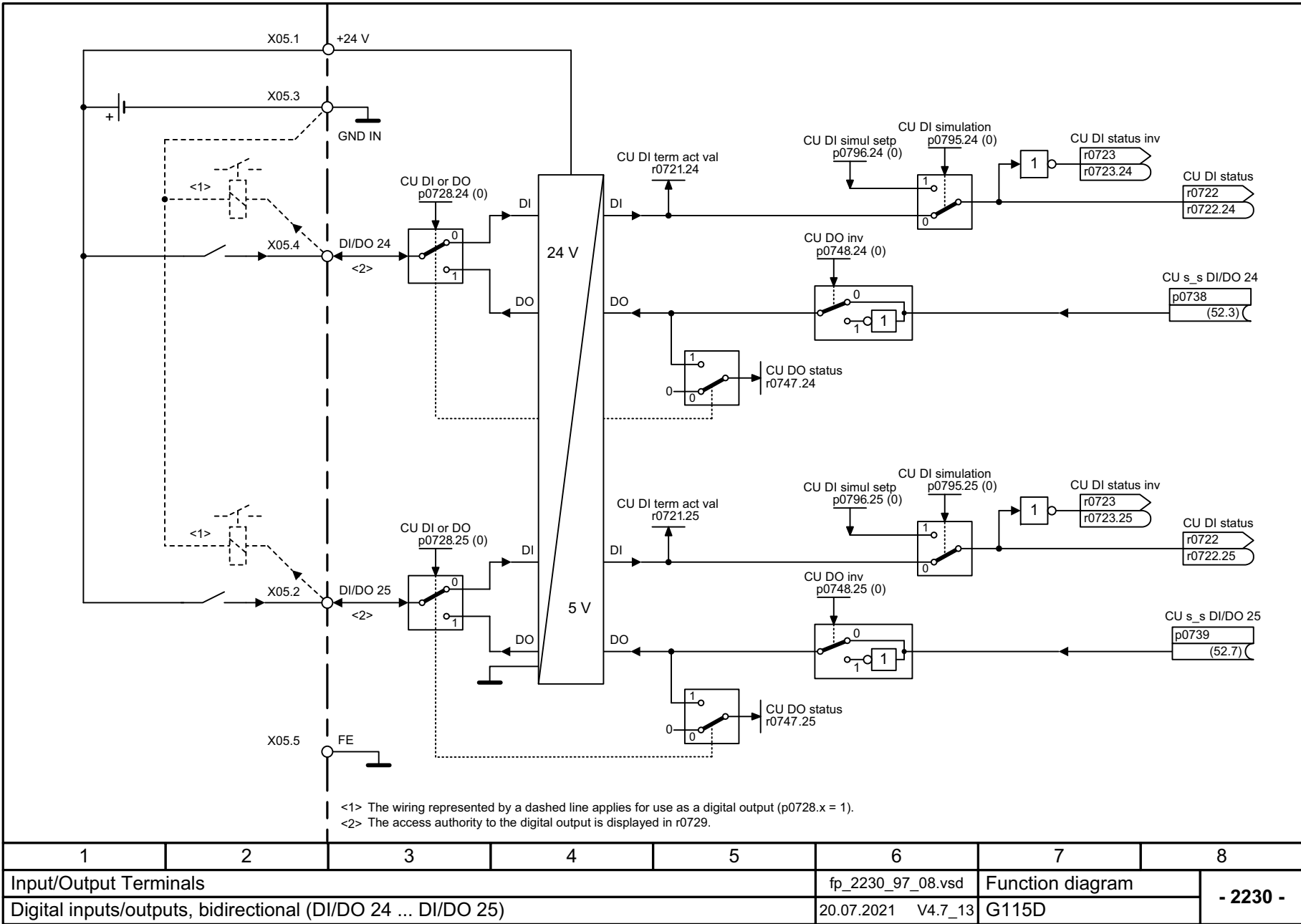
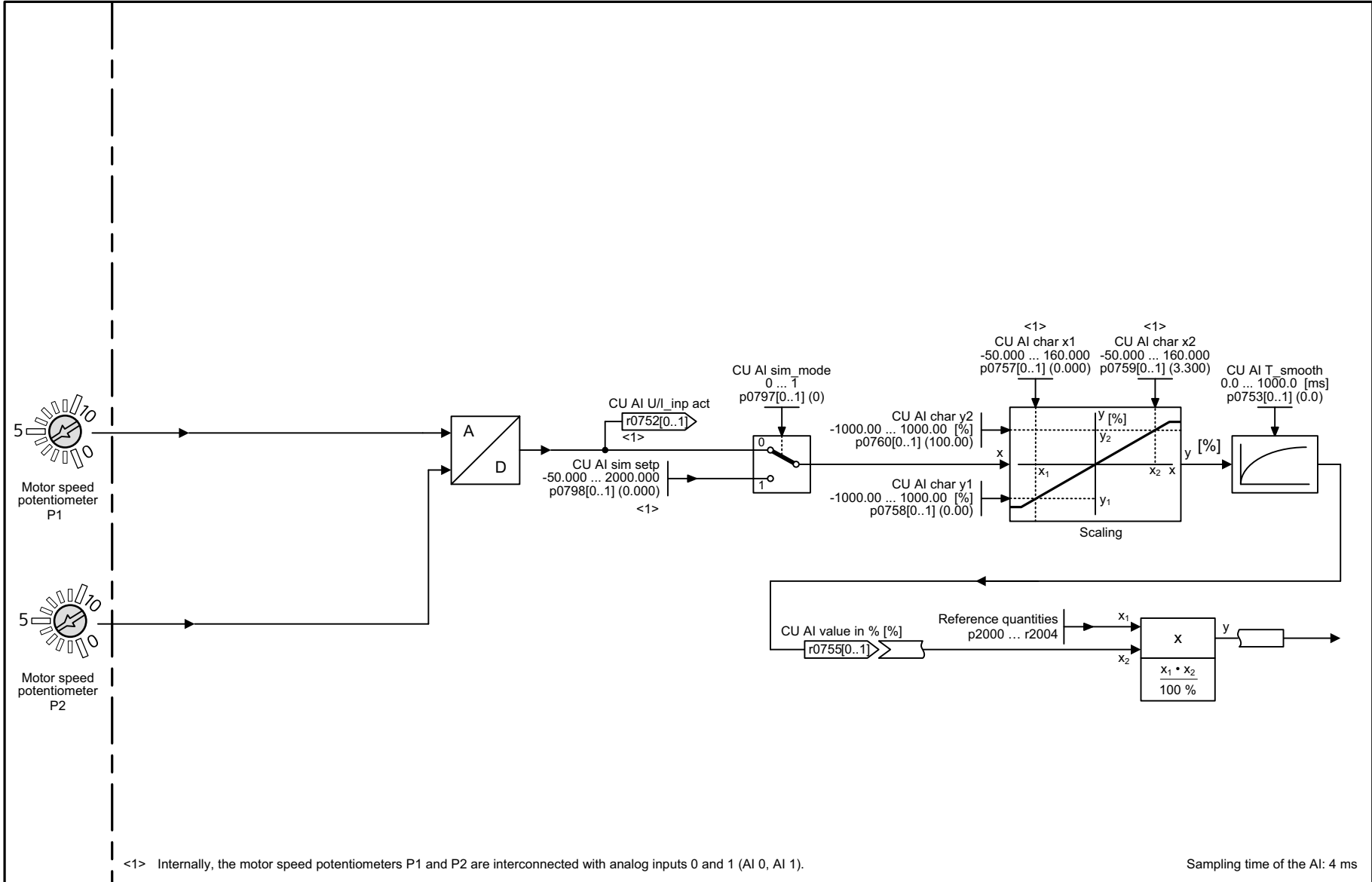

Fig. 3-7 2230 – Digital inputs/outputs bidirectional (DI/DO 24 ... DI/DO 25)

Fig. 3-8 2251 – Motor speed potentiometers 1 and 2



1	2	3	4	5	6	7	8
Input/Output Terminals					fp_2251_97_08.vsd	Function diagram	
Motor speed potentiometer P1 and P2					20.07.2021 V4.7_13	G115D	
							- 2251 -

**Two-wire control (p0015 = 62 or p3334 = 2)
clockwise/counterclockwise 2**

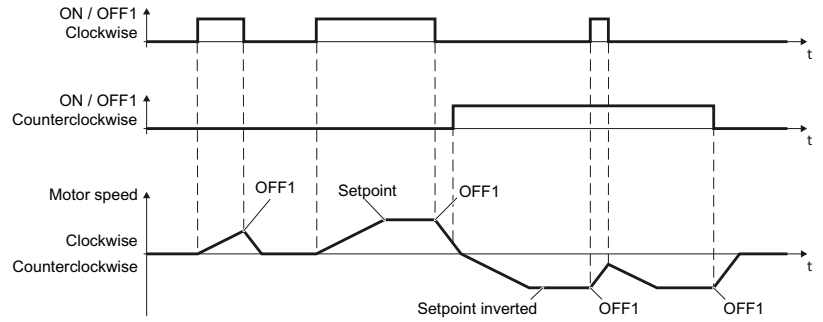
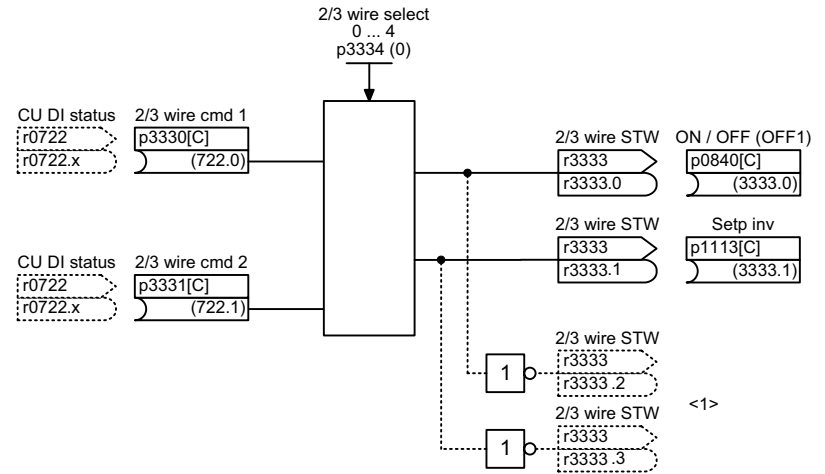

**Two-wire control (p0015 = 61 or p3334 = 1)
clockwise/counterclockwise 1**

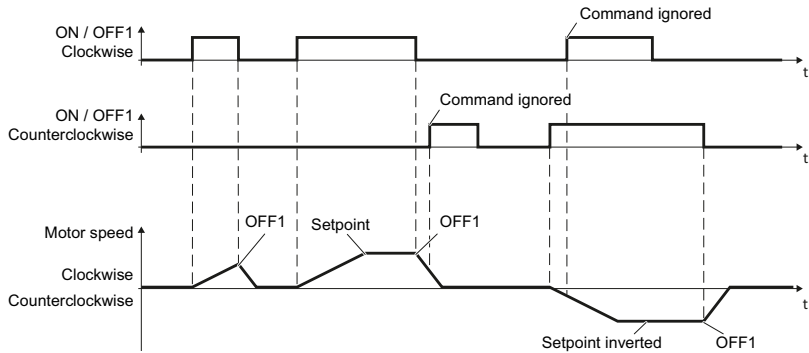
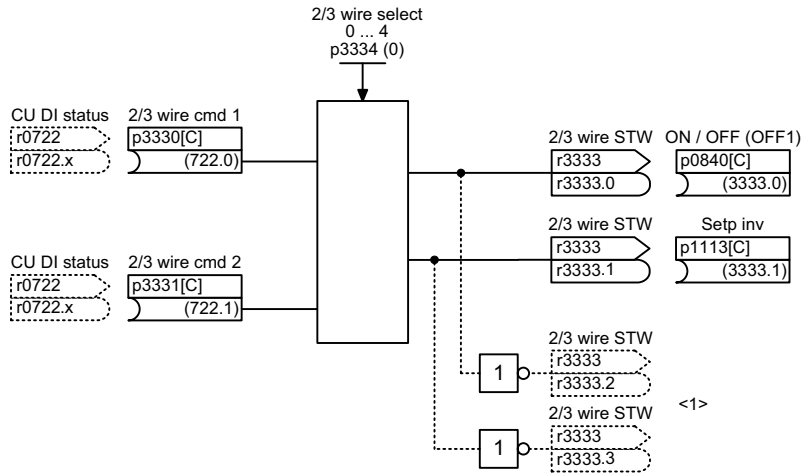

<1> Ongoing interconnection is either possible from r3333.0/r3333.1 or from the inverted signals r3333.2/r3333.3.

1	2	3	4	5	6	7	8
Input/Output Terminals					fp_2272_97_08.vsd	Function diagram	
Two-wire control					20.07.2021 V4.7_13	G115D	

Fig. 3-9

2272 – Two-wire control

Fig. 3-10 2273 – Three-wire control

**Three-wire control (p0015 = 63 or p3334 = 3)
enable clockwise/counterclockwise**

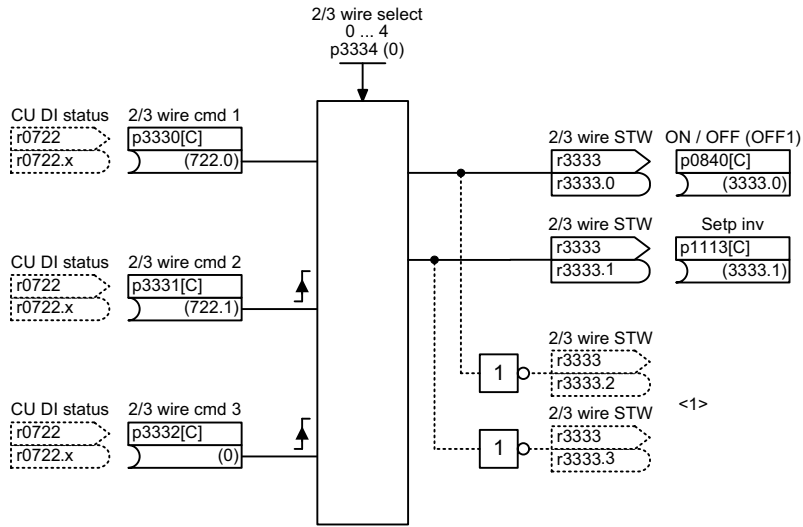

**Three-wire control (p0015 = 64 or p3334 = 4)
enable ON/reversing**

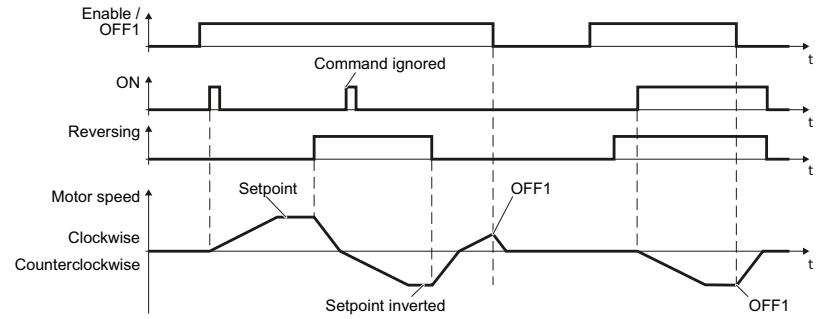
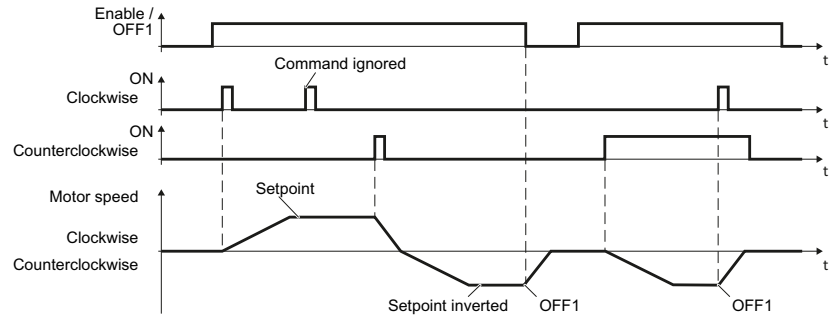
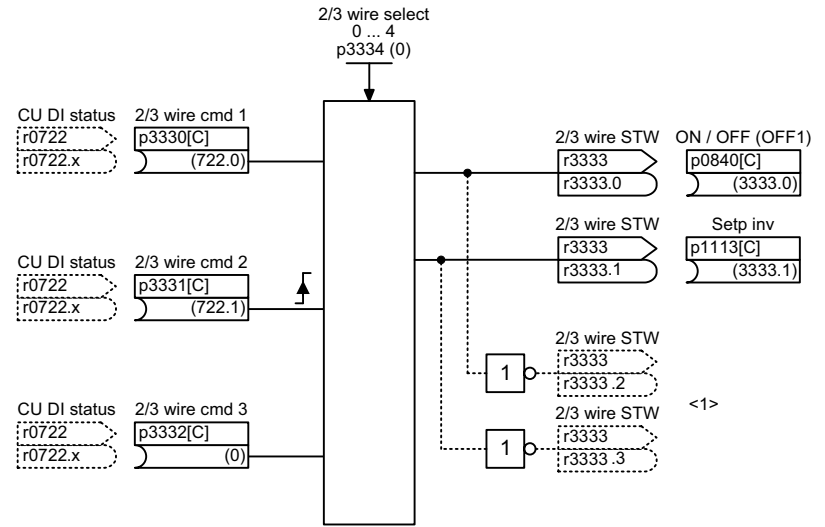

<1> Ongoing interconnection is either possible from r3333.0/r3333.1 or from the inverted signals r3333.2/r3333.3.

1	2	3	4	5	6	7	8
Input/Output Terminals					fp_2273_97_08.vsd	Function diagram	
Three-wire control					20.07.2021 V4.7_13	G115D	
- 2273 -							

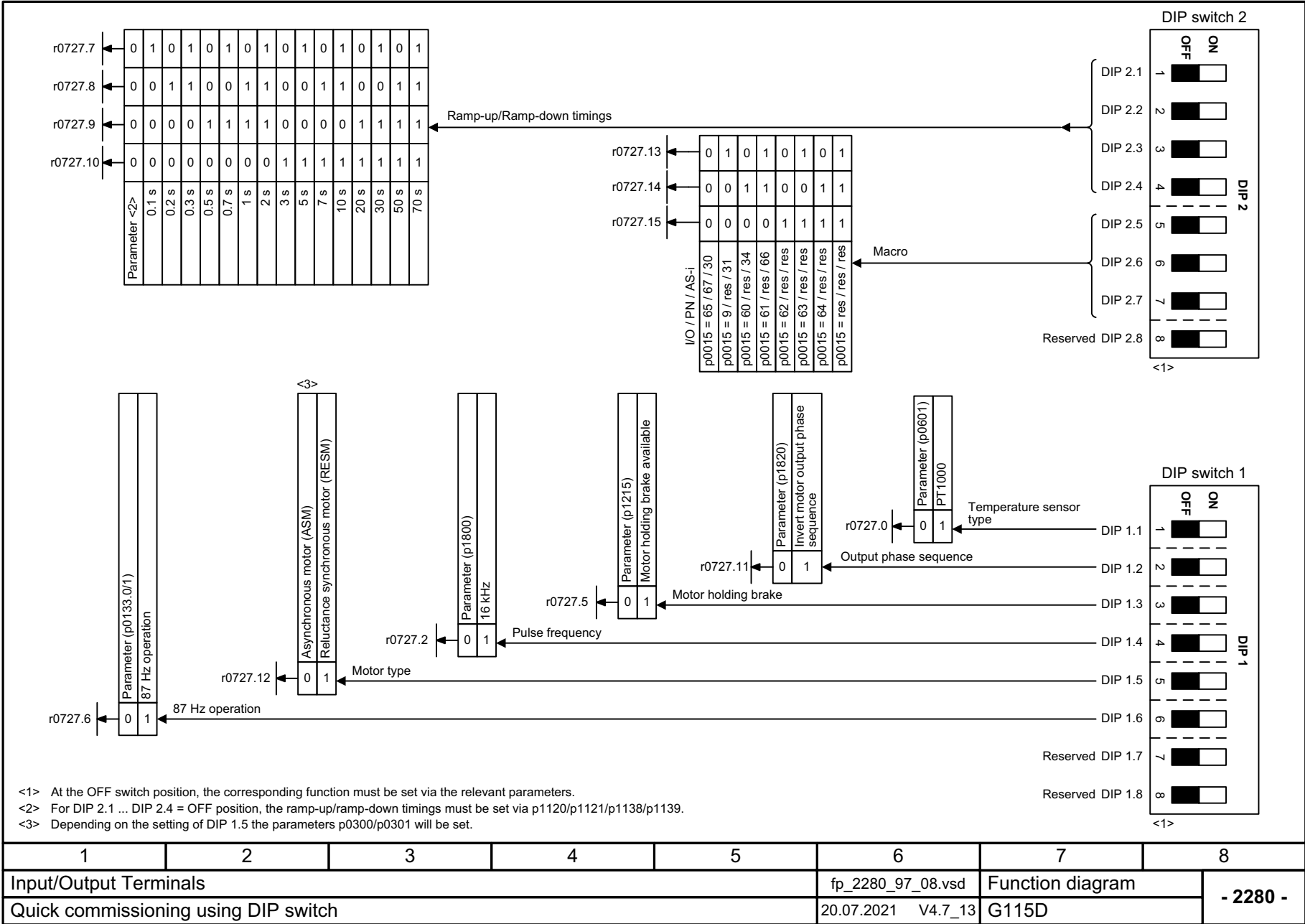

Fig. 3-11 2280 – Quick commissioning using DIP switch

3.4 PROFlenergy

Function diagrams

2381 – Control commands and interrogation commands	512
2382 – States	513

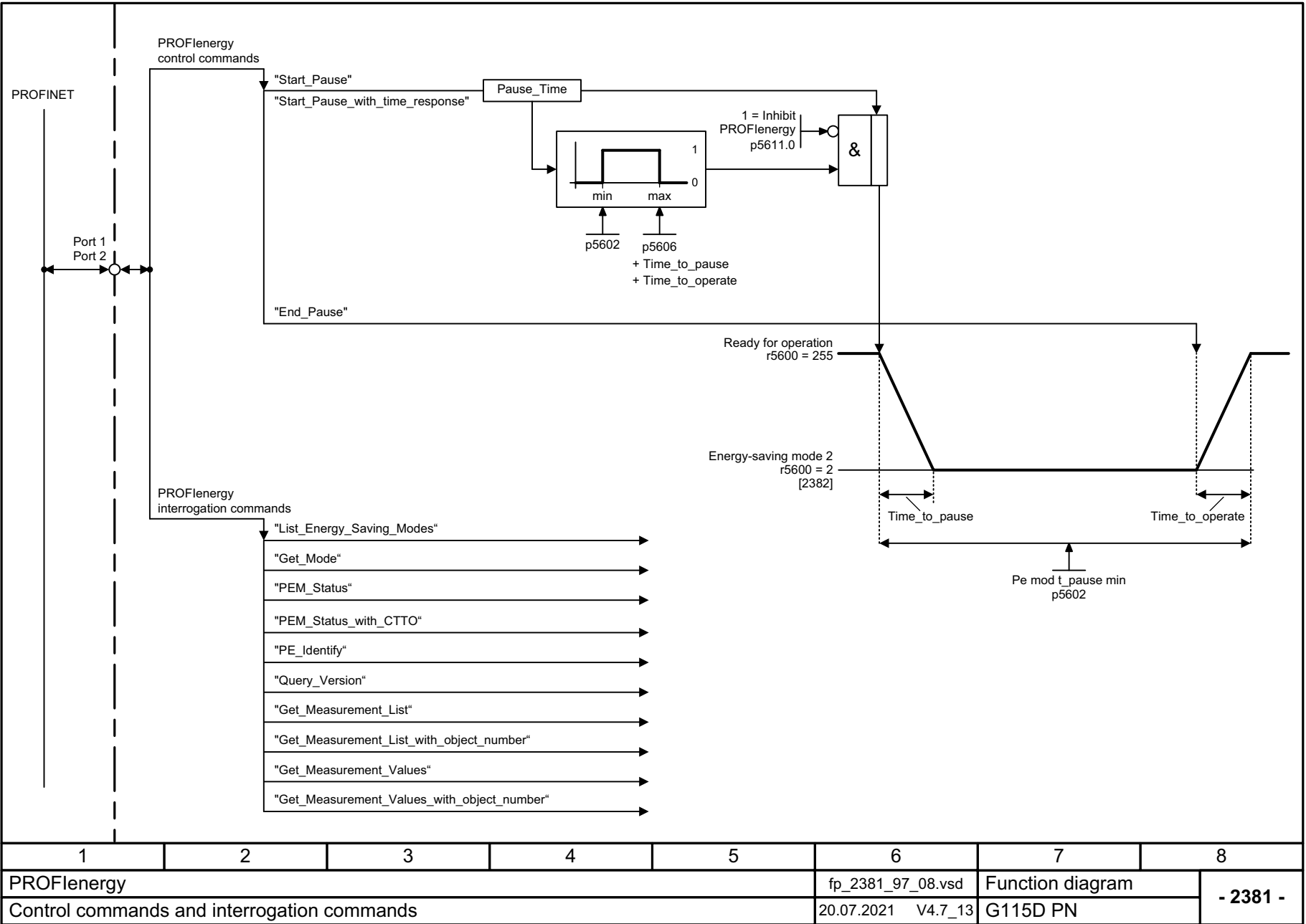
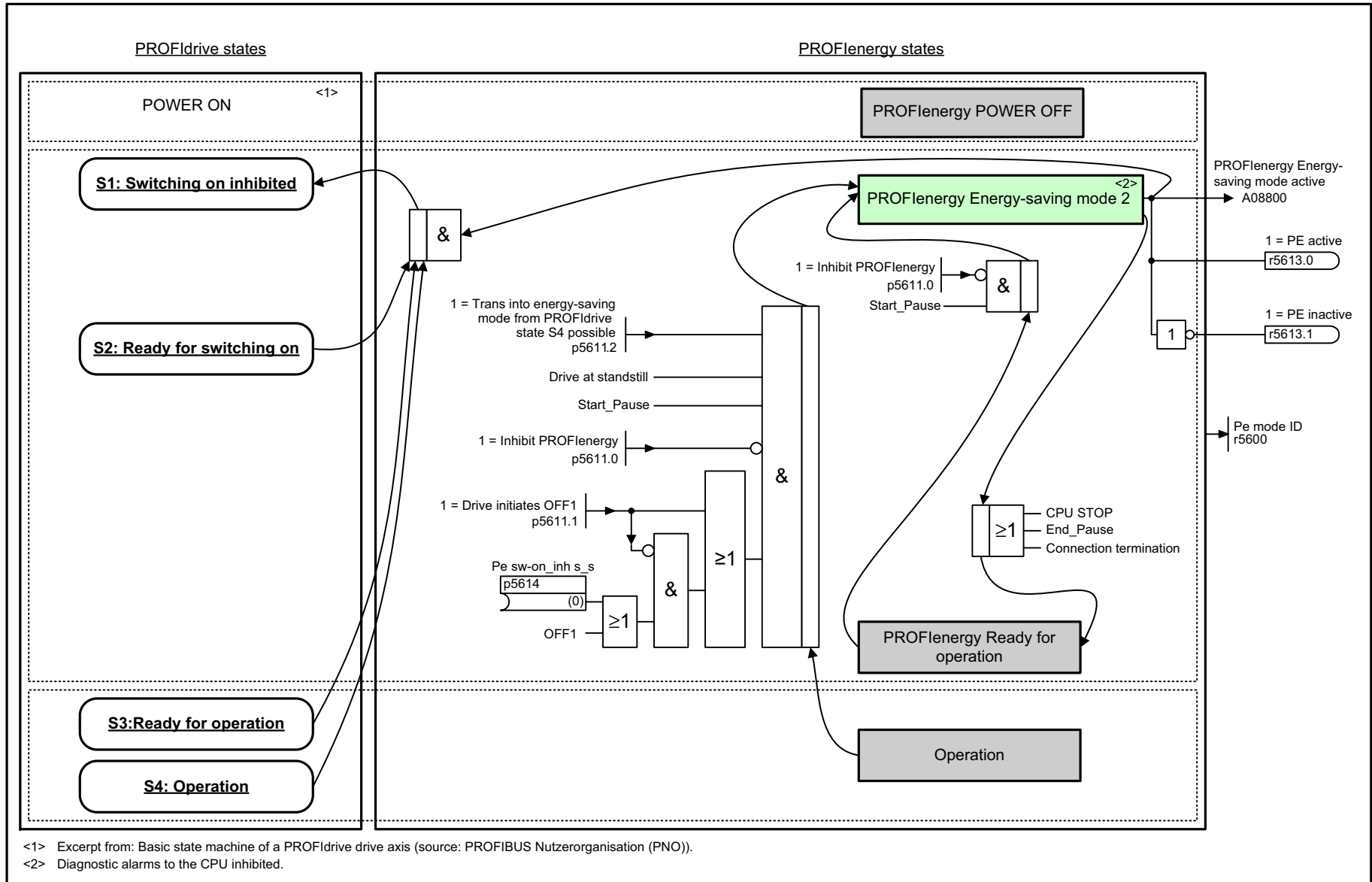

Fig. 3-12 2381 – Control commands and interrogation commands

1	2	3	4	5	6	7	8
PROFlenergy					fp_2381_97_08.vsd	Function diagram	
Control commands and interrogation commands					20.07.2021 V4.7_13	G115D PN	
							- 2381 -

Fig. 3-13 2382 – States



<1> Excerpt from: Basic state machine of a PROFdrive drive axis (source: PROFIBUS Nutzerorganisation (PNO)).
<2> Diagnostic alarms to the CPU inhibited.

1	2	3	4	5	6	7	8
PROFlenergy					fp_2382_97_61.vsd	Function diagram	
States					20.07.2021 V4.7_13	G115D PN	
							- 2382 -

3.5 Communication PROFIdrive (PROFINET), EtherNet/IP

Function diagrams

2401 – Overview	515
2410 – PROFIdrive, EtherNet/IP - addresses and diagnostics	516
2420 – PROFIdrive - telegrams and process data (PZD)	517
2440 – PROFIdrive - PZD receive signals interconnection	518
2441 – PROFIdrive - STW1 control word interconnection (p2038 = 2)	519
2442 – PROFIdrive - STW1 control word interconnection (p2038 = 0)	520
2444 – PROFIdrive - STW2 control word interconnection (p2038 = 0)	521
2446 – PROFIdrive - STW3 control word interconnection	522
2448 – PROFIdrive - STW_G115D control word interconnection	523
2450 – PROFIdrive - PZD send signals interconnection	524
2451 – PROFIdrive - ZSW1 status word interconnection (p2038 = 2)	525
2452 – PROFIdrive - ZSW1 status word interconnection (p2038 = 0)	526
2454 – PROFIdrive - ZSW2 status word interconnection (p2038 = 0)	527
2456 – PROFIdrive - ZSW3 status word interconnection	528
2458 – PROFIdrive - ZSW_G115D status word interconnection	529
2468 – PROFIdrive - receive telegram, free interconnection via BICO (p0922 = 999)	530
2470 – PROFIdrive - send telegram, free interconnection via BICO (p0922 = 999)	531
2472 – PROFIdrive - status words, free interconnection	532
2473 – EtherNet/IP - control word / status word interconnection	533

Fig. 3-14 2401 – Overview

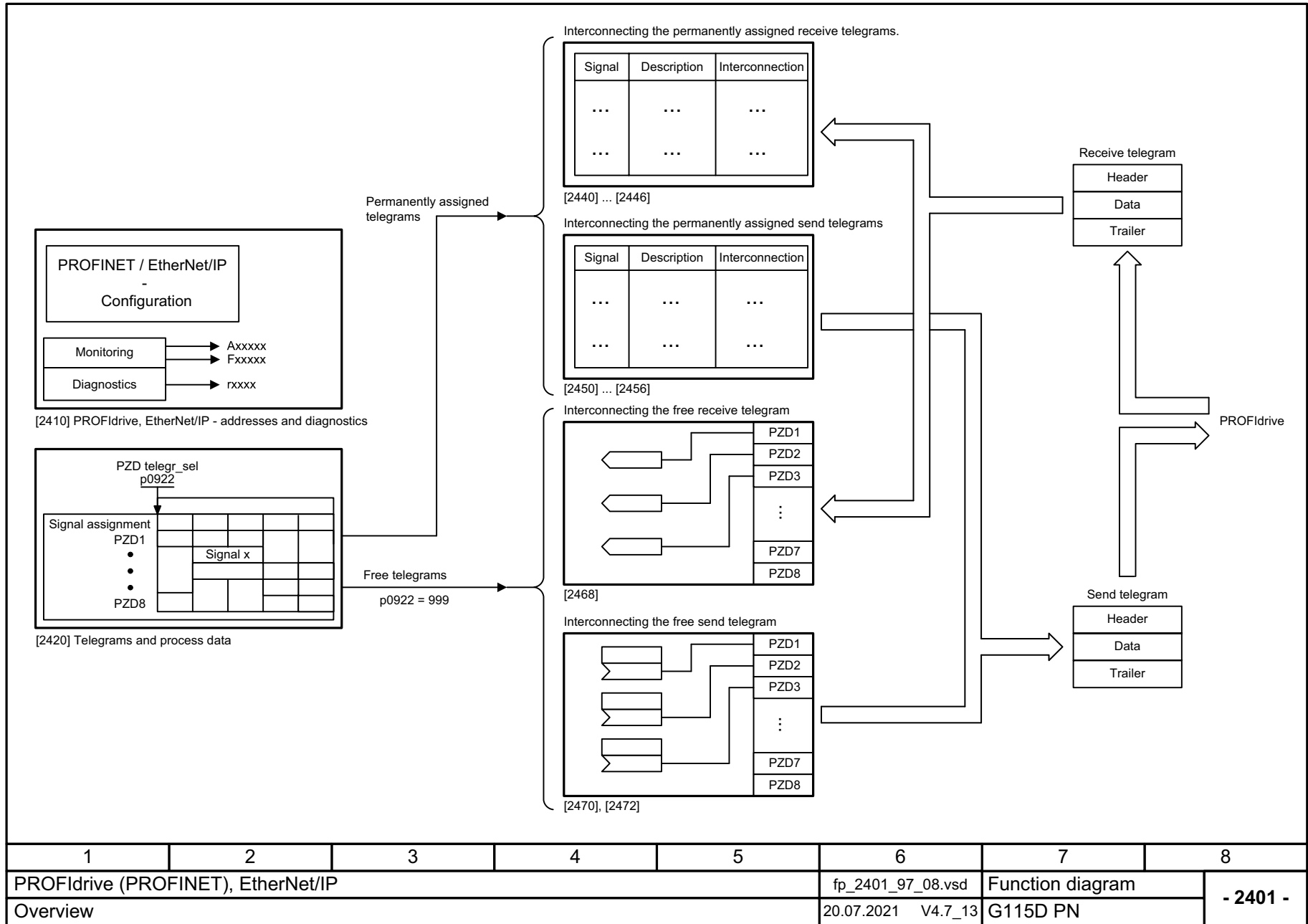

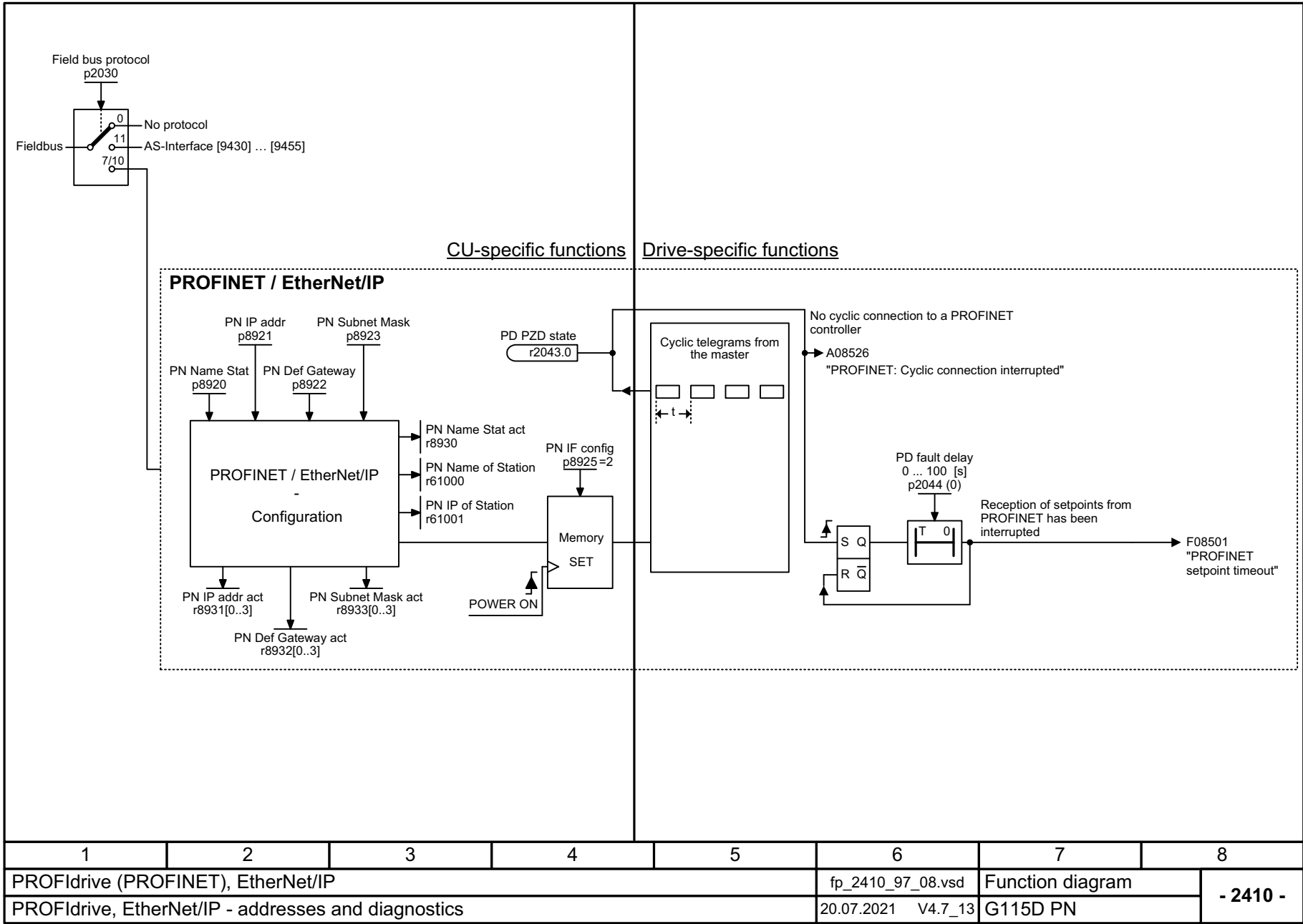

Fig. 3-15 2410 – PROFIdrive, EtherNet/IP - addresses and diagnostics

1	2	3	4	5	6	7	8
PROFIdrive (PROFINET), EtherNet/IP					fp_2410_97_08.vsd	Function diagram	
PROFIdrive, EtherNet/IP - addresses and diagnostics					20.07.2021 V4.7_13	G115D PN	
- 2410 -							

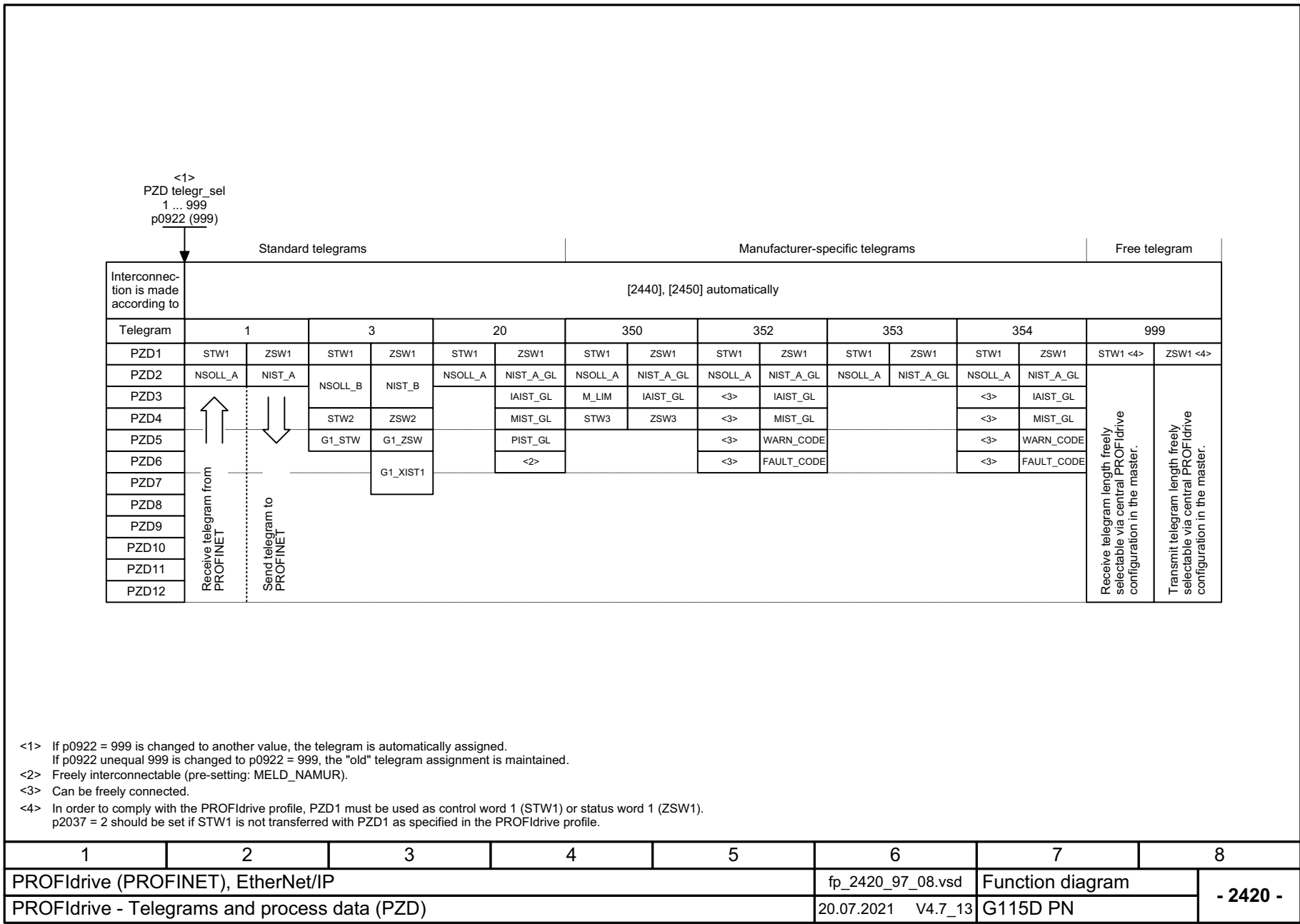

Fig. 3-16 2420 – PROFdrive - telegrams and process data (PZD)

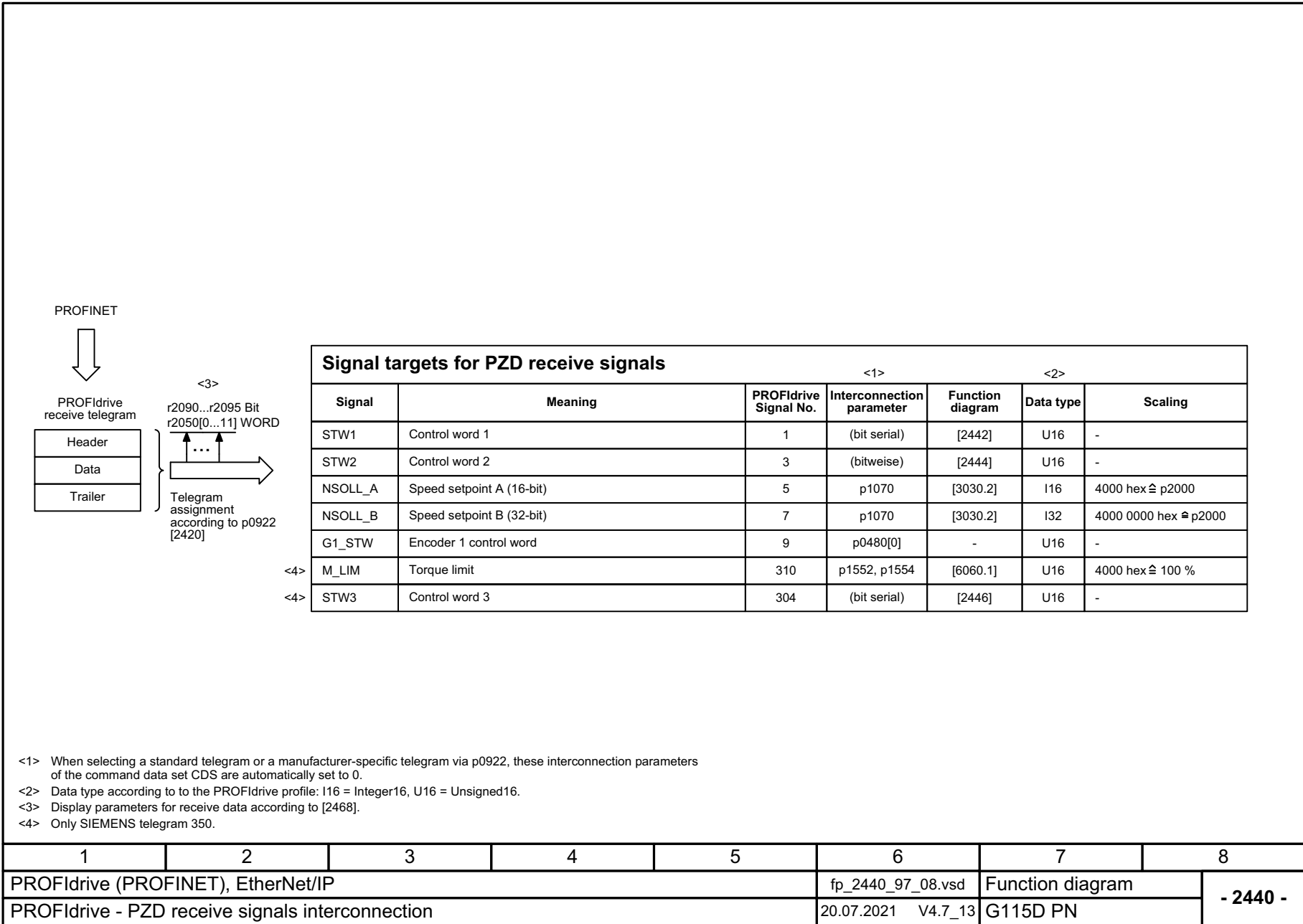

Fig. 3-17 2440 – PROFIdrive - PZD receive signals interconnection

Signal targets for STW1 in VIK-NAMUR telegram 20						<1>
Signal	Meaning	Interconnection parameters	[Function diagram] internal control word	[Function diagram] signal target	Inverted	
STW1.0	\overline{A} = ON (pulses can be enabled) 0 = OFF1 (braking with ramp-function generator, then pulse suppression & ready for switching on)	p0840[0] = r2090.0	[2501.3]	Sequence control	-	
STW1.1	1 = No OFF2 (enable is possible) 0 = OFF2 (immediate pulse suppression and switching on inhibited)	p0844[0] = r2090.1	[2501.3]	Sequence control	-	
STW1.2	1 = No OFF3 (enable is possible) 0 = OFF3 (braking with the OFF3 ramp p1135, then pulse suppression and switching on inhibited)	p0848[0] = r2090.2	[2501.3]	Sequence control	-	
STW1.3	1 = Enable operation (pulses can be enabled) 0 = Inhibit operation (suppress pulses)	p0852[0] = r2090.3	[2501.3]	Sequence control	-	
STW1.4	1 = Ramp-function generator enable 0 = Inhibit ramp-function generator (set the ramp-function generator output to zero)	p1140[0] = r2090.4	[2501.3]	[3060], [3070], [3080]	-	
STW1.5	1 = Continue ramp-function generator 0 = Freezes the ramp-function generator	p1141[0] = r2090.5	[2501.3]	[3060], [3070]	-	
STW1.6	1 = Setpoint enable 0 = Inhibits the setpoint (the ramp-function generator input is set to zero)	p1142[0] = r2090.6	[2501.3]	[3060], [3070], [3080]	-	
STW1.7	\overline{A} = Acknowledge faults	p2103[0] = r2090.7	[2546.1]	[8060]	-	
STW1.8	Reserved	-	-	-	-	
STW1.9	Reserved	-	-	-	-	
STW1.10	1 = Control via PLC	<2> p0854[0] = r2090.10	[2501.3]	[2501]	-	
STW1.11	1 = Dir of rot reversal	<4> p1113[0] = r2090.11	[2505.3]	[3040]	-	
STW1.12	Reserved	-	-	-	-	
STW1.13	Reserved	-	-	-	-	
STW1.14	Reserved	-	-	-	-	
STW1.15	1 = CDS selection	p0810[0] = 2090.15 <3>	-	[8560]	-	

<1> Used in telegram 20.

<2> Bit 10 in STW1 must be set to ensure that the drive accepts the process data.

<3> Interconnection is not disabled.

<4> The direction reversal can be locked (see p1110 and p1111).

1	2	3	4	5	6	7	8
PROFIdrive (PROFINET), EtherNet/IP					fp_2441_97_61.vsd	Function diagram	
PROFIdrive - STW1 control word interconnection (p2038 = 2)					20.07.2021 V4.7_13	G115D PN	
							- 2441 -

Fig. 3-18 2441 – PROFIdrive - STW1 control word interconnection (p2038 = 2)

Signal targets for STW1							
Signal	Meaning	Interconnection parameters	[Function diagram] internal control word	[Function diagram] signal target	Inverted		
STW1.0	▲ = ON (pulses can be enabled) 0 = OFF1 (braking with ramp-function generator, then pulse suppression & ready for switching on)	p0840[0] = r2090.0	[2501.3]	Sequence control	-		
STW1.1	1 = No OFF2 (enable is possible) 0 = OFF2 (immediate pulse suppression and switching on inhibited)	p0844[0] = r2090.1	[2501.3]	Sequence control	-		
STW1.2	1 = No OFF3 (enable is possible) 0 = OFF3 (braking with the OFF3 ramp p1135, then pulse suppression and switching on inhibited)	p0848[0] = r2090.2	[2501.3]	Sequence control	-		
STW1.3	1 = Enable operation (pulses can be enabled) 0 = Inhibit operation (suppress pulses)	p0852[0] = r2090.3	[2501.3]	Sequence control	-		
STW1.4	1 = Ramp-function generator enable 0 = Inhibit ramp-function generator (set the ramp-function generator output to zero)	p1140[0] = r2090.4	[2501.3]	[3060], [3070], [3080]	-		
STW1.5	1 = Continue ramp-function generator 0 = Freezes the ramp-function generator	p1141[0] = r2090.5	[2501.3]	[3060], [3070]	-		
STW1.6	1 = Setpoint enable 0 = Inhibits the setpoint (the ramp-function generator input is set to zero)	p1142[0] = r2090.6	[2501.3]	[3060], [3070], [3080]	-		
STW1.7	▲ = Acknowledge faults	p2103[0] = r2090.7	[2546.1]	[8060]	-		
STW1.8	Reserved	-	-	-	-		
STW1.9	Reserved	-	-	-	-		
STW1.10	1 = Control via PLC	<1> p0854[0] = r2090.10	[2501.3]	[2501]	-		
STW1.11	1 = Dir of rot reversal	<2> p1113[0] = r2090.11	[2505.3]	[3040]	-		
STW1.12	Reserved	-	-	-	-		
STW1.13	1 = Motorized potentiometer, setpoint, raise	p1035[0] = r2090.13	[2505.3]	[3020]	-		
STW1.14	1 = Motorized potentiometer, setpoint, lower	p1036[0] = r2090.14	[2505.3]	[3020]	-		
STW1.15	Reserved	-	-	-	-		
<1> Bit 10 in STW1 must be set to ensure that the drive accepts the process data. <2> The direction reversal can be locked (see p1110 and p1111).							
1	2	3	4	5	6	7	8
PROFIdrive (PROFINET), EtherNet/IP				fp_2442_97_61.vsd		Function diagram	
PROFIdrive - STW1 control word interconnection (p2038 = 0)				20.07.2021 V4.7_13		G115D PN	
							- 2442 -

Fig. 3-19 2442 – PROFIdrive - STW1 control word interconnection (p2038 = 0)

Signal targets for STW2							
Signal	Meaning	Interconnection parameters	[Function diagram] internal control word	[Function diagram] signal target	Inverted		
STW2.0	Drive Data Set selection DDS bit 0	p0820[0] = r2093.0	-	[8565]	-		
STW2.1	Drive Data Set selection DDS bit 1	p0821[0] = r2093.1	-	[8565]	-		
STW2.2	Reserved	-	-	-	-		
STW2.3	Reserved	-	-	-	-		
STW2.4	Reserved	-	-	-	-		
STW2.5	Reserved	-	-	-	-		
STW2.6	Reserved	-	-	-	-		
STW2.7	1 = Parking axis is selected	p0897 = r2093.7	-	-	-		
STW2.8	Reserved	-	-	-	-		
STW2.9	Reserved	-	-	-	-		
STW2.10	Reserved	-	-	-	-		
STW2.11	Reserved	-	-	-	-		
STW2.12	Reserved	-	-	-	-		
STW2.13	Reserved	-	-	-	-		
STW2.14	Reserved	-	-	-	-		
STW2.15	Reserved	-	-	-	-		
1	2	3	4	5	6	7	8
PROFIdrive (PROFINET), EtherNet/IP				fp_2444_97_08.vsd	Function diagram		- 2444 -
PROFIdrive - STW2 control word interconnection (p2038 = 0)				20.07.2021 V4.7_13	G115D PN		

Fig. 3-20 2444 – PROFIdrive - STW2 control word interconnection (p2038 = 0)

Signal targets for STW3 <1>					
Signal	Meaning	Interconnection parameters	[Function diagram] internal control word	[Function diagram] signal target	Inverted
STW3.0	1 = Fixed setp bit 0	p1020[0] = r2093.0	[2505.2]	[3010.2]	-
STW3.1	1 = Fixed setp bit 1	p1021[0] = r2093.1	[2505.2]	[3010.2]	-
STW3.2	1 = Fixed setp bit 2	p1022[0] = r2093.2	[2505.2]	[3010.2]	-
STW3.3	1 = Fixed setp bit 3	p1023[0] = r2093.3	[2505.2]	[3010.2]	-
STW3.4	1 = DDS select. bit 0	p0820 = r2093.4	[2513.2]	[8565.2]	-
STW3.5	1 = DDS select. bit 1	p0821 = r2093.5	[2513.2]	[8565.2]	-
STW3.6	Reserved	-	-	-	-
STW3.7	Reserved	-	-	-	-
STW3.8	1 = Technology controller enable	p2200[0] = r2093.8	[2513.2]	[7958.4]	-
STW3.9	1 = DC braking active	p1230[0] = r2093.9	[2513.2]	[7017.1]	-
STW3.10	Reserved	-	-	-	-
STW3.11	1 = Droop enable	p1492[0] = r2093.11	[2513.2]	[6030.1]	-
STW3.12	1 = Torque control	p1501[0] = r2093.12	[2513.2]	[6060.1]	-
STW3.13	0 = External fault 1 (F07860)	p2106[0] = r2093.13	[2513.2]	[8060.1]	-
STW3.14	Reserved	-	-	-	-
STW3.15	1 = CDS bit 1	p0811[0] = r2093.15	[2513.2]	[8560.3]	-

<1> Used in telegram 350.

1	2	3	4	5	6	7	8
PROFdrive (PROFINET), EtherNet/IP					fp_2446_97_51.vsd	Function diagram	
PROFdrive - STW3 control word interconnection					20.07.2021 V4.7_13	G115D PN	

- 2446 -

Fig. 3-21 2446 – PROFdrive - STW3 control word interconnection

Signal targets for STW_G115D							
Signal	Meaning	Interconnection parameters	[Function diagram] internal control word	[Function diagram] signal target	Inverted		
STW_G115D.0	DO 24	p0738 = r2094.0	-	-	-		
STW_G115D.1	DO 25	p0739 = r2094.1	-	-	-		
STW_G115D.2	1 = Stop/low speed sensor bypass	p3390 = r2094.2	-	-	-		
STW_G115D.3	Reserved	-	-	-	-		
STW_G115D.4	Reserved	-	-	-	-		
STW_G115D.5	Reserved	-	-	-	-		
STW_G115D.6	Reserved	-	-	-	-		
STW_G115D.7	Reserved	-	-	-	-		
STW_G115D.8	Reserved	-	-	-	-		
STW_G115D.9	Reserved	-	-	-	-		
STW_G115D.10	Reserved	-	-	-	-		
STW_G115D.11	Reserved	-	-	-	-		
STW_G115D.12	Reserved	-	-	-	-		
STW_G115D.13	Reserved	-	-	-	-		
STW_G115D.14	Reserved	-	-	-	-		
STW_G115D.15	Reserved	-	-	-	-		
1	2	3	4	5	6	7	8
PROFIdrive (PROFINET), EtherNet/IP				fp_2448_97_08.vsd	Function diagram		- 2448 -
PROFIdrive - STW_G115D control word interconnection				20.07.2021 V4.7_13	G115D PN		

Fig. 3-22 2448 – PROFIdrive - STW_G115D control word interconnection

Signal sources for PZD send signals						
Signal	Description	PROFdrive Signal No.	Interconnection parameter	Function diagram	Data type	Scaling
ZSW1	Status word 1	2	r2089[0]	[2452]	U16	-
ZSW2	Status word 2	4	r2089[1]	[2454]	U16	-
NIST_A	Actual speed A (16 bit)	6	r0063[0]	[6020.2]	I16	4000 hex $\hat{=}$ p2000
NIST_B	Actual speed B (32 bit)	8	r0063[0]	[6020.2]	I32	4000 0000 hex $\hat{=}$ p2000
G1_ZSW	Encoder 1 status word	10	r0481[0]	-	U16	
G1_XIST1	Encoder 1 position actual value 1	11	r0482[0]	[4704]	U32	-
IAIST_GLATT	Absolute actual current, smoothed	51	r0068[1]	[6799]	I16	4000 hex $\hat{=}$ p2002
MIST_GLATT	Actual torque smoothed	53	r0080[1]	[6799]	I16	4000 hex $\hat{=}$ p2003
PIST_GLATT	Power factor, smoothed	54	r0082[1]	[6799]	I16	4000 hex $\hat{=}$ p2004
NIST_A_GLATT	Actual speed, smoothed	57	r0063[1]	[6799]	I16	4000 hex $\hat{=}$ p2000
MELD_NAMUR	VIK-NAMUR message bit bar	58	r3113	-	U16	
FAULT_CODE	Fault code	301	r2131	[8060]	U16	
WARN_CODE	Alarm code	303	r2132	[8065]	U16	
ZSW3	Status word 3	305	r0053	[2456]	U16	

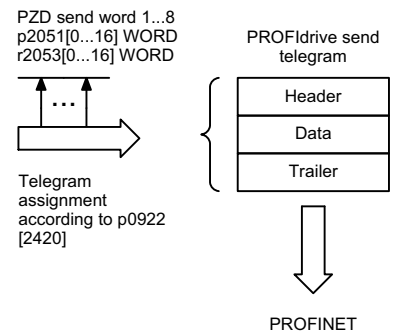

<1> Data type according to the PROFdrive profile: I16 = Integer16, U16 = Unsigned16.

1	2	3	4	5	6	7	8
PROFdrive (PROFINET), EtherNet/IP					fp_2450_97_08.vsd	Function diagram	
PROFdrive - PZD send signals interconnection					20.07.2021 V4.7_13	G115D PN	
- 2450 -							

Fig. 3-23 2450 – PROFdrive - PZD send signals interconnection

Fig. 3-24 2451 – PROFdrive - ZSW1 status word interconnection (p2038 = 2)

Signal sources for ZSW1 in VIK-NAMUR telegram 20							
Signal	Meaning	Interconnection parameters	[Function diagram] internal control word	[Function diagram] signal target	Inverted <1>		
ZSW1.0	1 = Ready for switching on	p2080[0] = r0899.0	[2503.7]	Sequence control	-		
ZSW1.1	1 = Ready for operation (DC link loaded, pulses inhibited)	p2080[1] = r0899.1	[2503.7]	Sequence control	-		
ZSW1.2	1 = Operation enabled (drive follows n_set)	p2080[2] = r0899.2	[2503.7]	Sequence control	-		
ZSW1.3	1 = Fault present	p2080[3] = r2139.3	[2548.7]	[8060]	-		
ZSW1.4	1 = No coast down active (OFF2 inactive)	p2080[4] = r0899.4	[2503.7]	Sequence control	-		
ZSW1.5	1 = No Quick stop active (OFF3 inactive)	p2080[5] = r0899.5	[2503.7]	Sequence control	-		
ZSW1.6	1 = Switching on inhibited active	p2080[6] = r0899.6	[2503.7]	Sequence control	-		
ZSW1.7	1 = Alarm present	p2080[7] = r2139.7	[2548.7]	[8065]	-		
ZSW1.8	1 = Speed setpoint - actual value deviation within tolerance t_off	p2080[8] = r2197.7	[2534.7]	[8011]	-		
ZSW1.9	1 = Control requested	p2080[9] = r0899.9	[2503.7]	[2503]	-		
ZSW1.10	1 = f or n comparison value reached/exceeded	p2080[10] = r2199.1	[2537.7]	[8010]	-		
ZSW1.11	1 = I, M, or P limit not reached	p2080[11] = r0056.13	[2522.7]	[6060]	✓		
ZSW1.12	Reserved	-	-	-	-		
ZSW1.13	1 = No motor overtemperature alarm	p2080[13] = r2135.14	[2548.7]	[8016]	✓		
ZSW1.14	1 = Motor rotates forwards (n_act ≥ 0)	p2080[14] = r2197.3	[2534.7]	[8011]	-		
ZSW1.15	1 = Display CDS	p2080[15] = r0836.0 <2>	-	-	-		
<1> The ZSW1 is generated using the binector-connector converter (BI: p2080[0...15], inversion: p2088[0]...p2088[0].15). <2> Interconnection is not disabled.							
1	2	3	4	5	6	7	8
PROFdrive (PROFINET), EtherNet/IP				fp_2451_97_61.vsd		Function diagram	
PROFdrive - ZSW1 status word interconnection (p2038 = 2)				20.07.2021 V4.7_13		G115D PN	
							- 2451 -

Signal sources for ZSW1					
Signal	Meaning	Interconnection parameters	[Function diagram] internal control word	[Function diagram] signal target	Inverted <1>
ZSW1.0	1 = Ready for switching on	p2080[0] = r0899.0	[2503.7]	Sequence control	-
ZSW1.1	1 = Ready for operation (DC link loaded, pulses inhibited)	p2080[1] = r0899.1	[2503.7]	Sequence control	-
ZSW1.2	1 = Operation enabled (drive follows n_set)	p2080[2] = r0899.2	[2503.7]	Sequence control	-
ZSW1.3	1 = Fault present	p2080[3] = r2139.3	[2548.7]	[8060]	-
ZSW1.4	1 = No coast down active (OFF2 inactive)	p2080[4] = r0899.4	[2503.7]	Sequence control	-
ZSW1.5	1 = No Quick stop active (OFF3 inactive)	p2080[5] = r0899.5	[2503.7]	Sequence control	-
ZSW1.6	1 = Switching on inhibited active	p2080[6] = r0899.6	[2503.7]	Sequence control	-
ZSW1.7	1 = Alarm present	p2080[7] = r2139.7	[2548.7]	[8065]	-
ZSW1.8	1 = Speed setpoint - actual value deviation within tolerance t_off	p2080[8] = r2197.7	[2534.7]	[8011]	-
ZSW1.9	1 = Control requested <2>	p2080[9] = r0899.9	[2503.7]	[2503]	-
ZSW1.10	1 = f or n comparison value reached/exceeded	p2080[10] = r2199.1	[2536.7]	[8010]	-
ZSW1.11	1 = I, M, or P limit not reached	p2080[11] = r1407.7	[2522.7]	[6060]	✓
ZSW1.12	1 = Open holding brake	p2080[12] = r0899.12	[2503.7]	[2701]	-
ZSW1.13	1 = No motor overtemperature alarm	p2080[13] = r2135.14	[2548.7]	[8016]	✓
ZSW1.14	1 = Motor rotates forwards (n_act ≥ 0)	p2080[14] = r2197.3	[2534.7]	[8011]	-
ZSW1.15	1 = No alarm, thermal overload, power unit	p2080[15] = r2135.15	[2548.7]	[8021]	✓

<1> The ZSW1 is generated using the binector-connector converter (BI: p2080[0...15], inversion: p2088[0]...p2088[0].15).

<2> The drive is ready to accept data.

1	2	3	4	5	6	7	8
PROFIdrive (PROFINET), EtherNet/IP					fp_2452_97_61.vsd	Function diagram	
PROFIdrive - ZSW1 status word interconnection (p2038 = 0)					20.07.2021 V4.7_13	G115D PN	

- 2452 -

Fig. 3-25 2452 – PROFIdrive - ZSW1 status word interconnection (p2038 = 0)

Signal sources for ZSW2							
Signal	Meaning	Interconnection parameters	[Function diagram] internal control word	[Function diagram] signal target	Inverted		
ZSW2.0	1 = DDS effective bit 0	p2081[0] = r0051.0	-	[8565]	-		
ZSW2.1	1 = DDS effective bit 1	p2081[1] = r0051.1	-	[8565]	-		
ZSW2.2	Reserved	-	-	-	-		
ZSW2.3	Reserved	-	-	-	-		
ZSW2.4	Reserved	-	-	-	-		
ZSW2.5	1 = Alarm class bit 0	p2081[5] = r2139.11	[2548.6]	-	-		
ZSW2.6	1 = Alarm class bit 1	p2081[6] = r2139.12	[2548.6]	-	-		
ZSW2.7	Reserved	-	-	-	-		
ZSW2.8	Reserved	-	-	-	-		
ZSW2.9	Reserved	-	-	-	-		
ZSW2.10	1 = Pulses enabled	p2081[10] = r0899.11	[2503.7]	-	-		
ZSW2.11	Reserved	-	-	-	-		
ZSW2.12	Reserved	-	-	-	-		
ZSW2.13	Reserved	-	-	-	-		
ZSW2.14	Reserved	-	-	-	-		
ZSW2.15	Reserved	-	-	-	-		
1	2	3	4	5	6	7	8
PROFdrive (PROFINET), EtherNet/IP				fp_2454_97_08.vsd	Function diagram		- 2454 -
PROFdrive - ZSW2 status word interconnection (p2038 = 0)				20.07.2021 V4.7_13	G115D PN		

Fig. 3-26 2454 – PROFdrive - ZSW2 status word interconnection (p2038 = 0)

Signal sources for ZSW3 <1>							
Signal	Meaning	Interconnection parameters	[Function diagram] internal status word	[Function diagram] signal source	Inverted		
ZSW3.0	1 = DC braking active	p2051[3] = r0053	[2511.7]	[7017.5]	-		
ZSW3.1	1 = n_act > p1226 (n_standstill)		[2511.7]	[2534.7]	-		
ZSW3.2	1 = n_act > p1080 (n_min)		[2511.7]	[2534.7]	-		
ZSW3.3	1 = l_act ≥ p2170		[2511.7]	[2534.7]	-		
ZSW3.4	1 = n_act > p2155		[2511.7]	[2534.7]	-		
ZSW3.5	1 = n_act ≤ p2155		[2511.7]	[2534.7]	-		
ZSW3.6	1 = n_act ≥ r1119 (n_set)		[2511.7]	[2534.7]	-		
ZSW3.7	1 = Vdc ≤ p2172		[2511.7]	[2534.7]	-		
ZSW3.8	1 = Vdc > p2172		[2511.7]	[2534.7]	-		
ZSW3.9	1 = Ramping finished		[2511.7]	[3080.7]	-		
ZSW3.10	1 = Technology controller output at the lower limit		[2511.7]	[7958.7]	-		
ZSW3.11	1 = Technology controller output at the upper limit		[2511.7]	[7958.7]	-		
ZSW3.12	Reserved		-	-	-		
ZSW3.13	Reserved		-	-	-		
ZSW3.14	Reserved		-	-	-		
ZSW3.15	Reserved	-	-	-			
<1> Used in telegram 350.							
1	2	3	4	5	6	7	8
PROFIdrive (PROFINET), EtherNet/IP			fp_2456_97_61.vsd		Function diagram		
PROFIdrive - ZSW3 status word interconnection			20.07.2021 V4.7_13		G115D PN		
							- 2456 -

Fig. 3-27 2456 – PROFIdrive - ZSW3 status word interconnection

Signal sources for ZSW_G115D							
Signal	Meaning	Interconnection parameters	[Function diagram] internal status word	[Function diagram] signal source	Inverted		
ZSW_G115D.0	DI 0	p2084[0] = r0722.0	-	[2220]	-		
ZSW_G115D.1	DI 1	p2084[1] = r0722.1	-	[2220]	-		
ZSW_G115D.2	DI 2	p2084[2] = r0722.2	-	[2220]	-		
ZSW_G115D.3	DI 3	p2084[3] = r0722.3	-	[2220]	-		
ZSW_G115D.4	DI 24	p2084[4] = r0722.24	-	[2230]	-		
ZSW_G115D.5	DI 25	p2084[5] = r0722.25	-	[2230]	-		
ZSW_G115D.6	Reserved	-	-	-	-		
ZSW_G115D.7	Reserved	-	-	-	-		
ZSW_G115D.8	1 = Repair switch is switched off	p2084[8] = r8559.12	[2507.7]	-	-		
ZSW_G115D.9	1 = Remote control active	p2084[9] = r8559.2	[2507.7]	-	-		
ZSW_G115D.10	1 = Manual mode active	p2084[10] = r8559.3	[2507.7]	-	-		
ZSW_G115D.11	1 = Sensor bypass activated	p2084[11] = r8559.4	[2507.7]	-	-		
ZSW_G115D.12	1 = Continuous motion activated	p2084[12] = r8559.5	[2507.7]	-	-		
ZSW_G115D.13	1 = Jog left active	p2084[13] = r8559.6	[2507.7]	-	-		
ZSW_G115D.14	1 = Jog right active	p2084[14] = r8559.7	[2507.7]	-	-		
ZSW_G115D.15	Reserved	-	-	-	-		
1	2	3	4	5	6	7	8
PROFIdrive (PROFINET), EtherNet/IP			fp_2458_97_08.vsd		Function diagram		- 2458 -
PROFIdrive - ZSW_G115D status word interconnection			20.07.2021 V4.7_13		G115D PN		

Fig. 3-28 2458 – PROFIdrive - ZSW_G115D status word interconnection

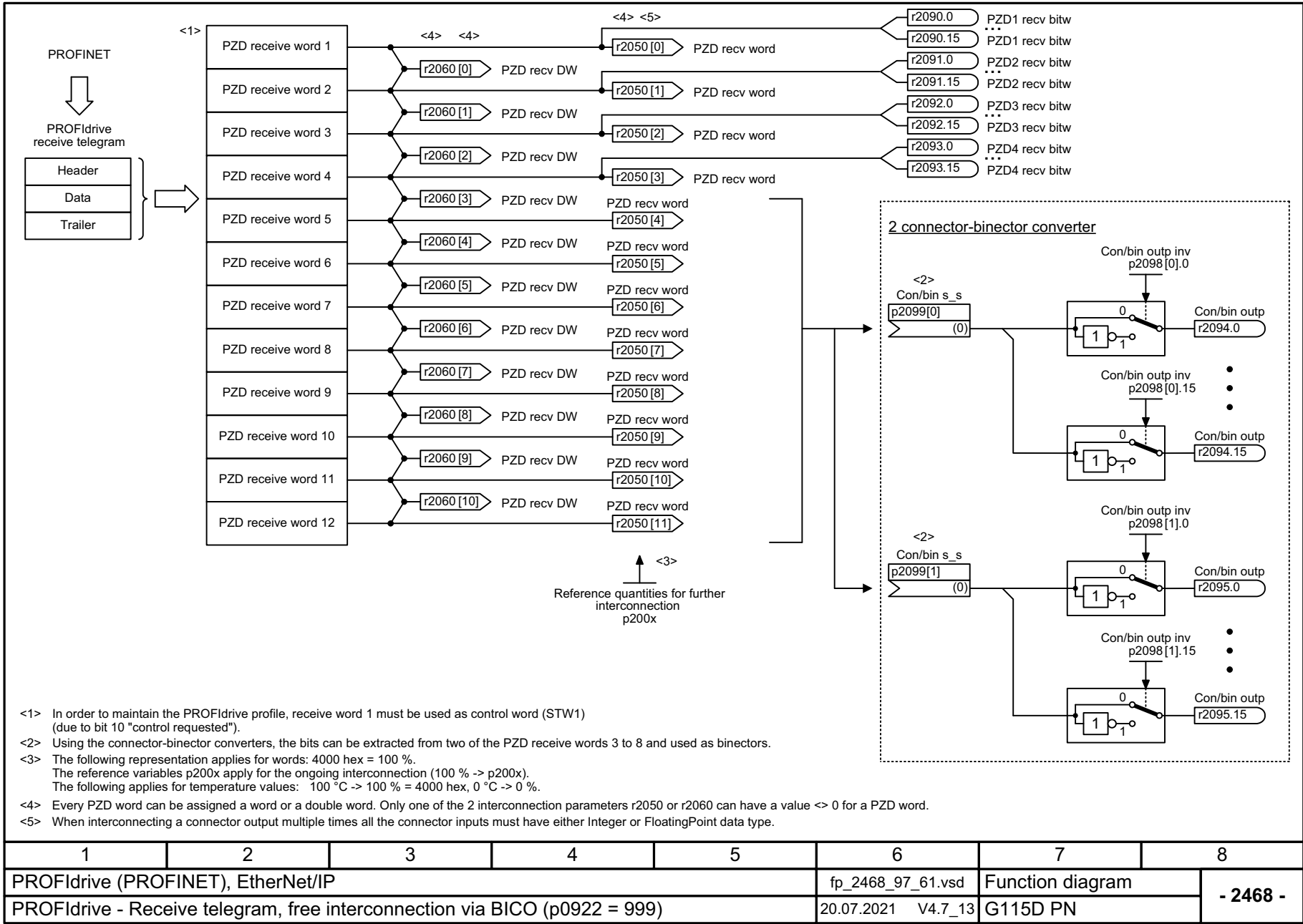
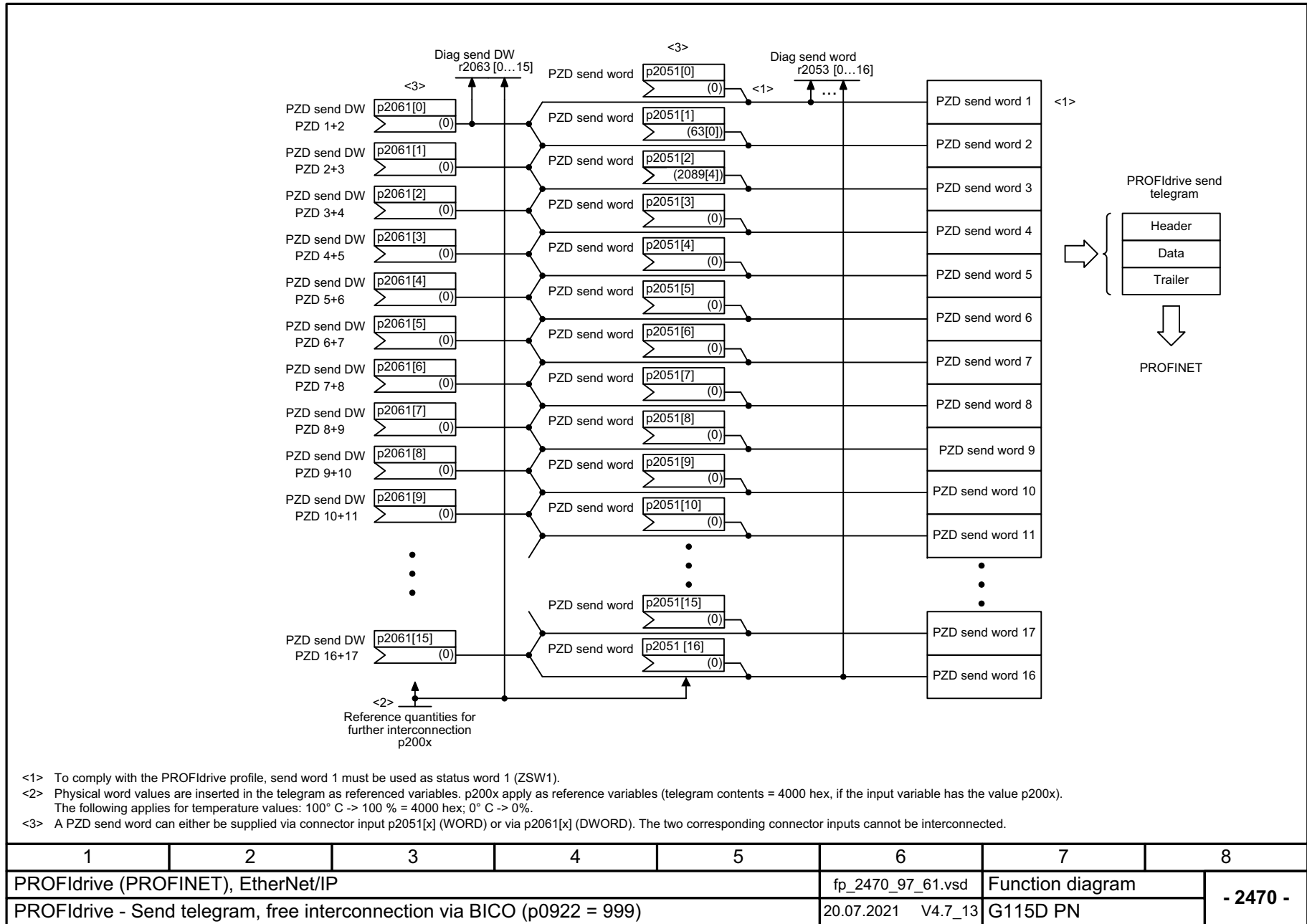
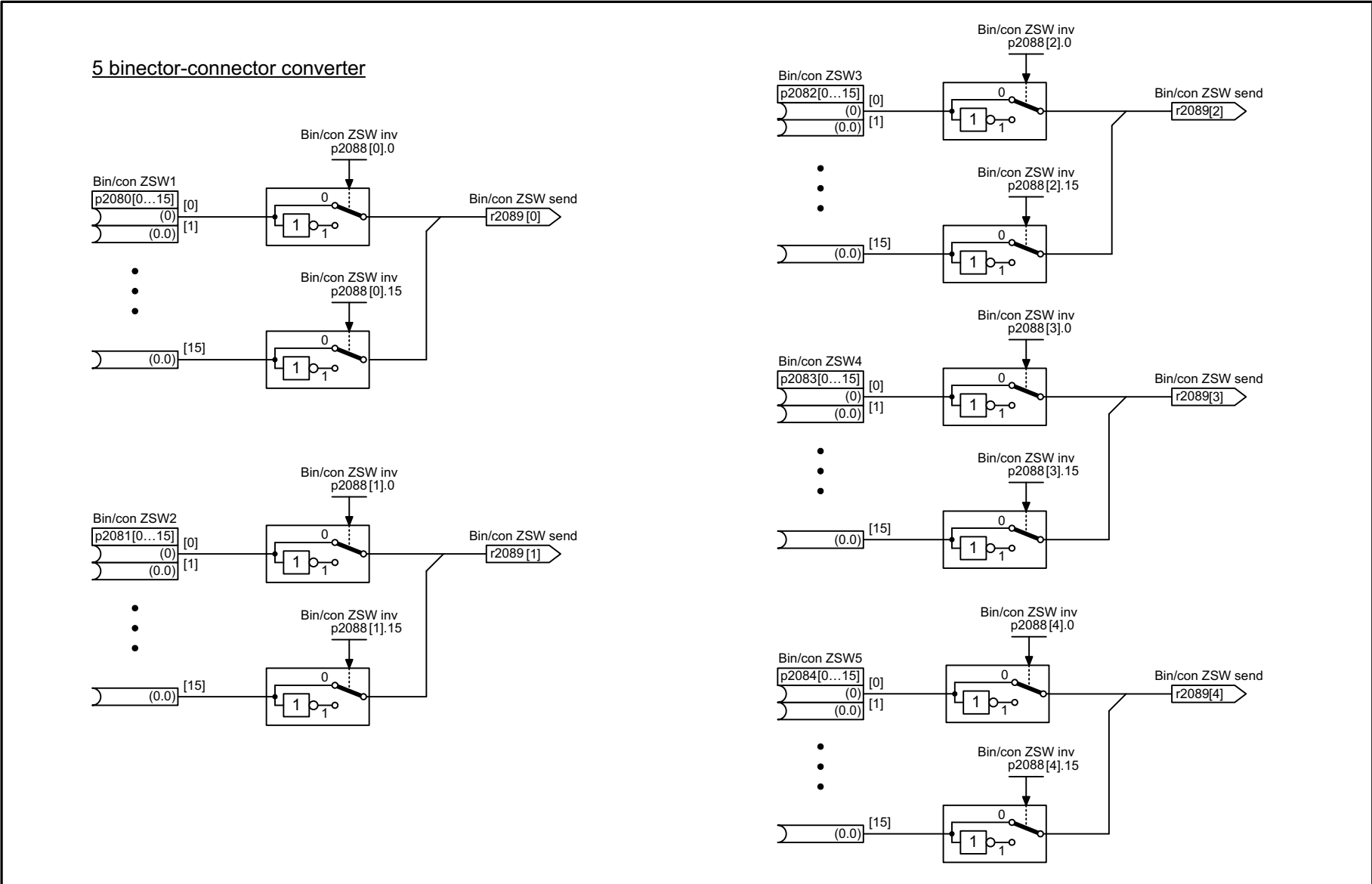

Fig. 3-29 2468 – PROFIdrive - receive telegram, free interconnection via BICO (p0922 = 999)

Fig. 3-30 2470 – PROFdrive - send telegram, free interconnection via BICO (p0922 = 999)



- <1> To comply with the PROFdrive profile, send word 1 must be used as status word 1 (ZSW1).
- <2> Physical word values are inserted in the telegram as referenced variables. p200x apply as reference variables (telegram contents = 4000 hex, if the input variable has the value p200x). The following applies for temperature values: 100° C -> 100 % = 4000 hex; 0° C -> 0%.
- <3> A PZD send word can either be supplied via connector input p2051[x] (WORD) or via p2061[x] (DWORD). The two corresponding connector inputs cannot be interconnected.



1	2	3	4	5	6	7	8
PROFIdrive (PROFINET), EtherNet/IP					fp_2472_97_51.vsd	Function diagram	
PROFIdrive - Status words, free interconnection					20.07.2021 V4.7_13	G115D PN	

Fig. 3-31 2472 – PROFIdrive - status words, free interconnection

Fig. 3-32 2473 – EtherNet/IP - control word / status word interconnection

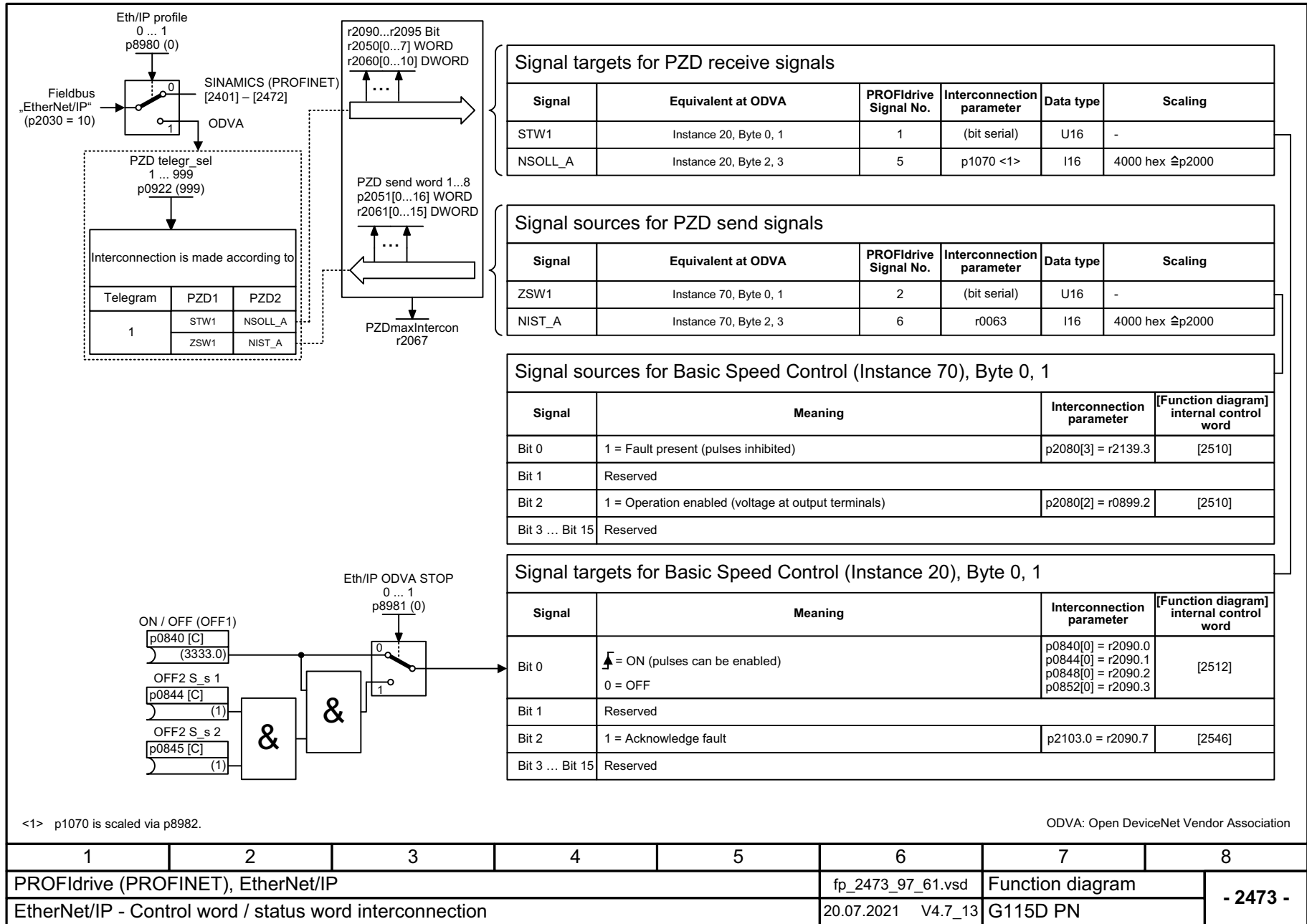

3.6 Communication, fieldbus interface (AS-Interface)

Function diagrams

9430 – Configuration, addresses and diagnostics	535
9431 – Interconnection overview	536
9435 – STW1 control word interconnection (p0015 = 30/31/34)	537
9438 – STW3 control word interconnection	538
9445 – ZSW1 status word interconnection	539
9455 – Fixed speed setpoints (p0015 = 30/31, p1016 = 2)	540

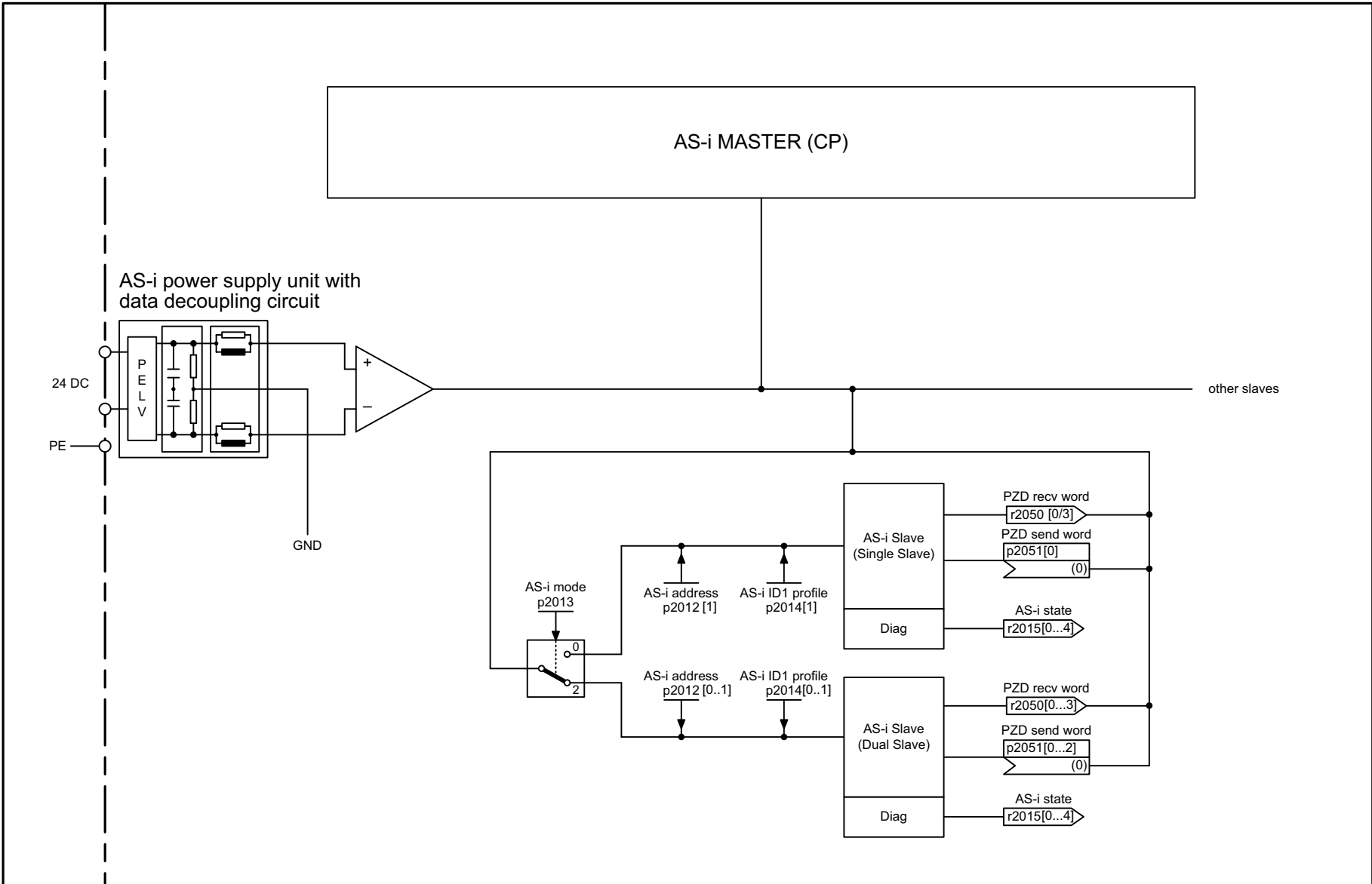

1	2	3	4	5	6	7	8
Fieldbus Interface (AS-Interface)					fp_9430_97_70.vsd	Function diagram	
Configuration, addresses and diagnostics					20.07.2021 V4.7_13	G115D AS-i	

- 9430 -

Fig. 3-33 9430 – Configuration, addresses and diagnostics

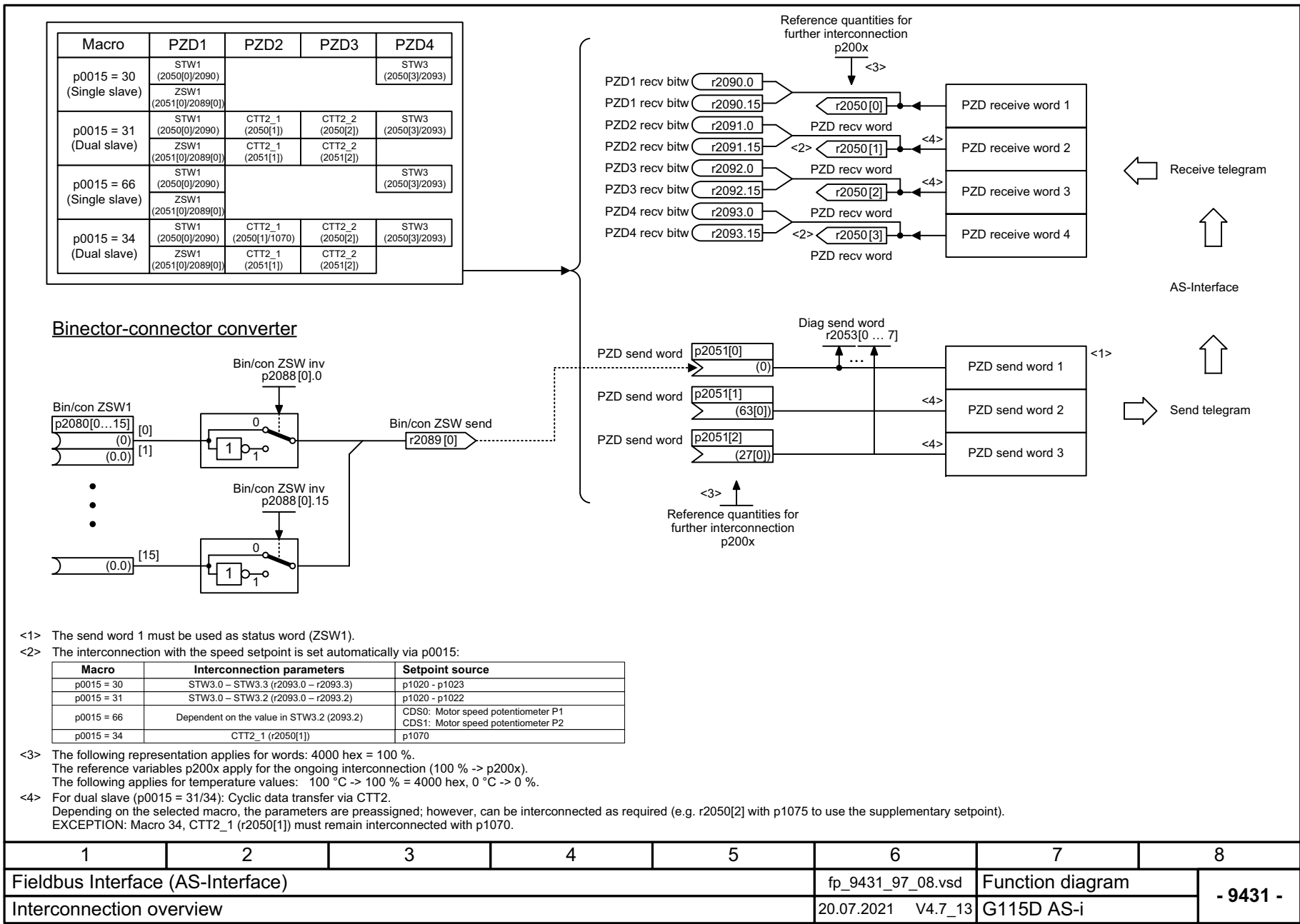



Fig. 3-34 9431 – Interconnection overview

Signal targets for fieldbus STW1					
Signal	Meaning	Interconnection parameter	[Function diagram] internal control word	[Function diagram] signal target	Inverted
STW1.0	$\overline{1}$ = ON (pulses can be enabled) 0 = OFF1 (braking with ramp-function generator, then pulse suppression & ready for switching on)	p0840[0] = r2090.0	-	-	-
STW1.1	1 = No OFF2 (enable is possible) 0 = OFF2 (immediate pulse suppression and switching on inhibited)	p0844[0] = r2090.1	-	-	-
...	Reserved	-	-	-	-
STW1.7	$\overline{1}$ = Acknowledge faults	p2104[0] = r2090.7	-	-	-
...	Reserved	-	-	-	-
STW1.15	Reserved	-	-	-	-

1	2	3	4	5	6	7	8
Fieldbus Interface (AS-Interface)					fp_9435_97_70.vsd	Function diagram	
STW1 control word interconnection (p0015 = 30/31/34)					20.07.2021 V4.7_13	G115D AS-i	
							- 9435 -

Fig. 3-35 9435 – STW1 control word interconnection (p0015 = 30/31/34)

Signal targets for fieldbus STW3						
This applies to macro:	Signal	Meaning	Interconnection parameter	[Function diagram] signal target	[Function diagram] internal control word	
p0015 = 30	STW3.0	1 = Fixed setp bit 0	p1020 = r2093.0	[9455]	[2505]	
	STW3.1	1 = Fixed setp bit 1	p1021 = r2093.1	[9455]	[2505]	
	STW3.2	1 = Fixed setp bit 2	p1022 = r2093.2	[9455]	[2505]	
	STW3.3	1 = Fixed setp bit 3	p1023 = r2093.3	[9455]	[2505]	
p0015 = 31	STW3.0	1 = Fixed setp bit 0	p1020 = r2093.0	[9455]	[2505]	
	STW3.1	1 = Fixed setp bit 1	p1021 = r2093.1	[9455]	[2505]	
	STW3.2	1 = Fixed setp bit 2	p1022 = r2093.2	[9455]	[2505]	
	STW3.4	Quickstop override	p3390 = r2093.4	Sequence control	-	
p0015 = 66	STW3.0	2/3-wire control command 1	p3330 = r2093.0	[2272, 2273]	-	
	STW3.1	2/3-wire control command 2	p3331 = r2093.1	[2272, 2273]	-	
	STW3.2	0 = CDS 0 1 = CDS 1	p0810 = r2093.2	[8560]	-	
	STW3.3	Fault present:	 = Acknowledge fault	p2104 = r2093.3	-	[2512]
		No fault present:	1 = Enable operation (pulses can be enabled) 0 = Inhibit operation (suppress pulses)	p0852 = r2093.3	Sequence control	[2501]
p0015 = 34	STW3.4	Quickstop override	p3390 = r2093.4	Sequence control	-	

1	2	3	4	5	6	7	8
Fieldbus Interface (AS-Interface)					fp_9438_97_70.vsd	Function diagram	
STW3 control word interconnection					20.07.2021 V4.7_13	G115D AS-i	
							- 9438 -

Fig. 3-36 9438 – STW3 control word interconnection

Signal sources for fieldbus ZSW1					
This applies to macro:	Signal	Meaning	Interconnection parameter	[Function diagram] signal target	[Function diagram] internal control word
p0015 = 30	ZSW1.0	1 = Ready for switching on	p2080[0] = r0053.13	-	[2511]
	ZSW1.1	1 = Pulses enabled	p2080[1] = r0899.11	-	[2503]
	ZSW1.2	DI 0	p2080[2] = r0722.0	[2220]	-
	ZSW1.3	DI 1	p2080[3] = r0722.1	[2220]	-
p0015 = 31	ZSW1.0	1 = Ready for switching on	p2080[0] = r0053.13	-	[2511]
	ZSW1.1	1 = Pulses enabled	p2080[1] = r0899.11	-	[2503]
	ZSW1.2	DI 0	p2080[2] = r0722.0	[2220]	-
	ZSW1.3	DI 1	p2080[3] = r0722.1	[2220]	-
	ZSW1.4	DI 2	p2080[4] = r0722.2	[2220]	-
	ZSW1.5	DI 3	p2080[5] = r0722.3	[2220]	-
p0015 = 66	ZSW1.0	1 = Ready for switching on	p2080[0] = r0899.0	-	[2511]
	ZSW1.1	1 = PcCtrl active	p2080[1] = r0807.0	[3030]	-
	ZSW1.2	DI 0	p2080[2] = r0722.0	[2220]	-
	ZSW1.3	DI 1	p2080[3] = r0722.1	[2220]	-
p0015 = 34	ZSW1.0	1 = Ready for switching on	p2080[0] = r0053.13	-	[2511]
	ZSW1.1	1 = Pulses enabled	p2080[1] = r0899.11	-	[2503]
	ZSW1.2	DI 0	p2080[2] = r0722.0	[2220]	-
	ZSW1.3	DI 1	p2080[3] = r0722.1	[2220]	-
	ZSW1.4	DI 2	p2080[4] = r0722.2	[2220]	-
	ZSW1.5	DI 3	p2080[5] = r0722.3	[2220]	-

1	2	3	4	5	6	7	8
Fieldbus Interface (AS-Interface)					fp_9445_97_70.vsd	Function diagram	
ZSW1 status word interconnection					20.07.2021 V4.7_13	G115D AS-i	
							- 9445 -

Fig. 3-37 9445 – ZSW1 status word interconnection



<1> r2093.3 is only used for macro p0015 = 30.

1	2	3	4	5	6	7	8
Fieldbus Interface (AS-Interface)					fp_9455_97_70.vsd	Function diagram	
Fixed speed setpoints (p0015 = 30/31, p1016 = 2)					20.07.2021 V4.7_13	G115D AS-i	

- 9455 -

Fig. 3-38 9455 – Fixed speed setpoints (p0015 = 30/31, p1016 = 2)

3.7 Internal control/status words

Function diagrams

2501 – Control word sequence control (r0898)	542
2503 – Status word sequence control (r0899)	543
2505 – Control word setpoint channel (r1198)	544
2507 – status word key status (r8559)	545
2510 – Status word 1 (r0052)	546
2511 – Status word 2 (r0053)	547
2512 – Control word 1 (r0054)	548
2513 – Supplementary control word (r0055)	549
2520 – Control word speed controller (r1406)	550
2522 – Status word speed controller (r1407)	551
2526 – Status word closed-loop control (r0056)	552
2530 – Status word current control (r1408)	553
2534 – Status word monitoring functions 1 (r2197)	554
2536 – Status word monitoring functions 2 (r2198)	555
2537 – Status word monitoring functions 3 (r2199)	556
2546 – Control word faults/alarms (r2138)	557
2548 – Status word faults/alarms 1 and 2 (r2139 and r2135)	558
2610 – Sequence control - Sequencer	559
2634 – Sequence control - missing enable signals, line contactor control	560

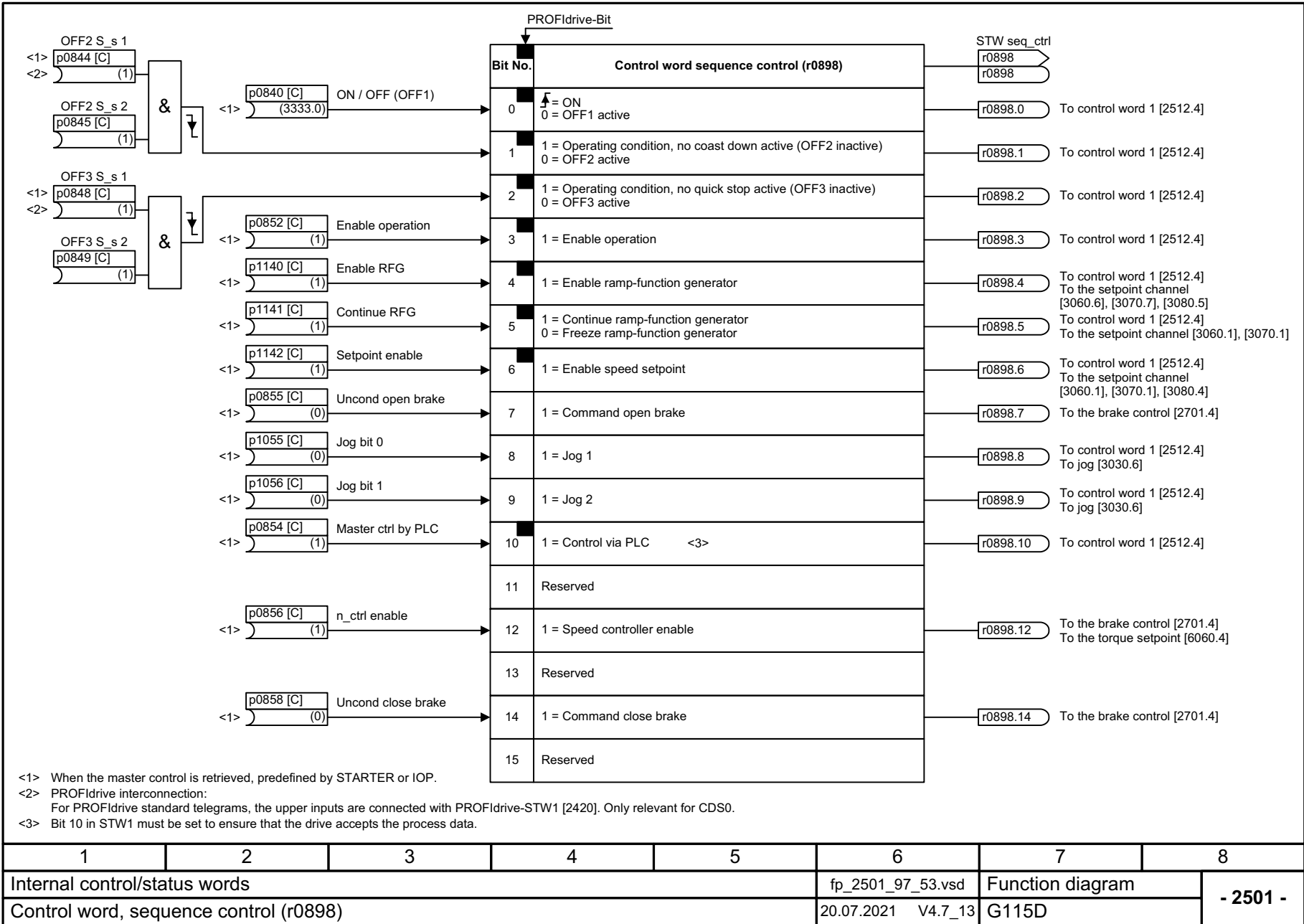
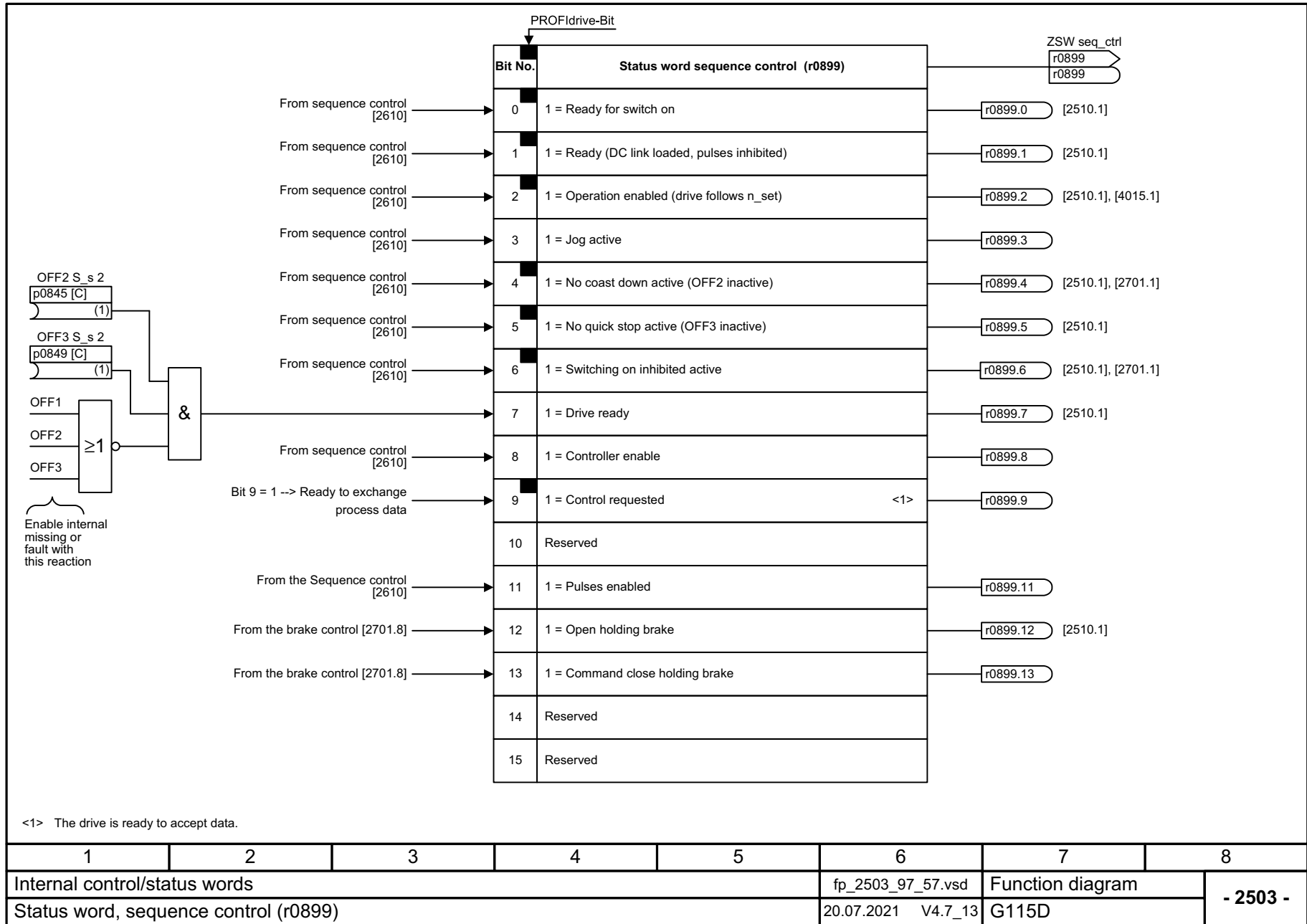

Fig. 3-39 2501 – Control word sequence control (r0898)

Fig. 3-40 2503 – Status word sequence control (r0899)



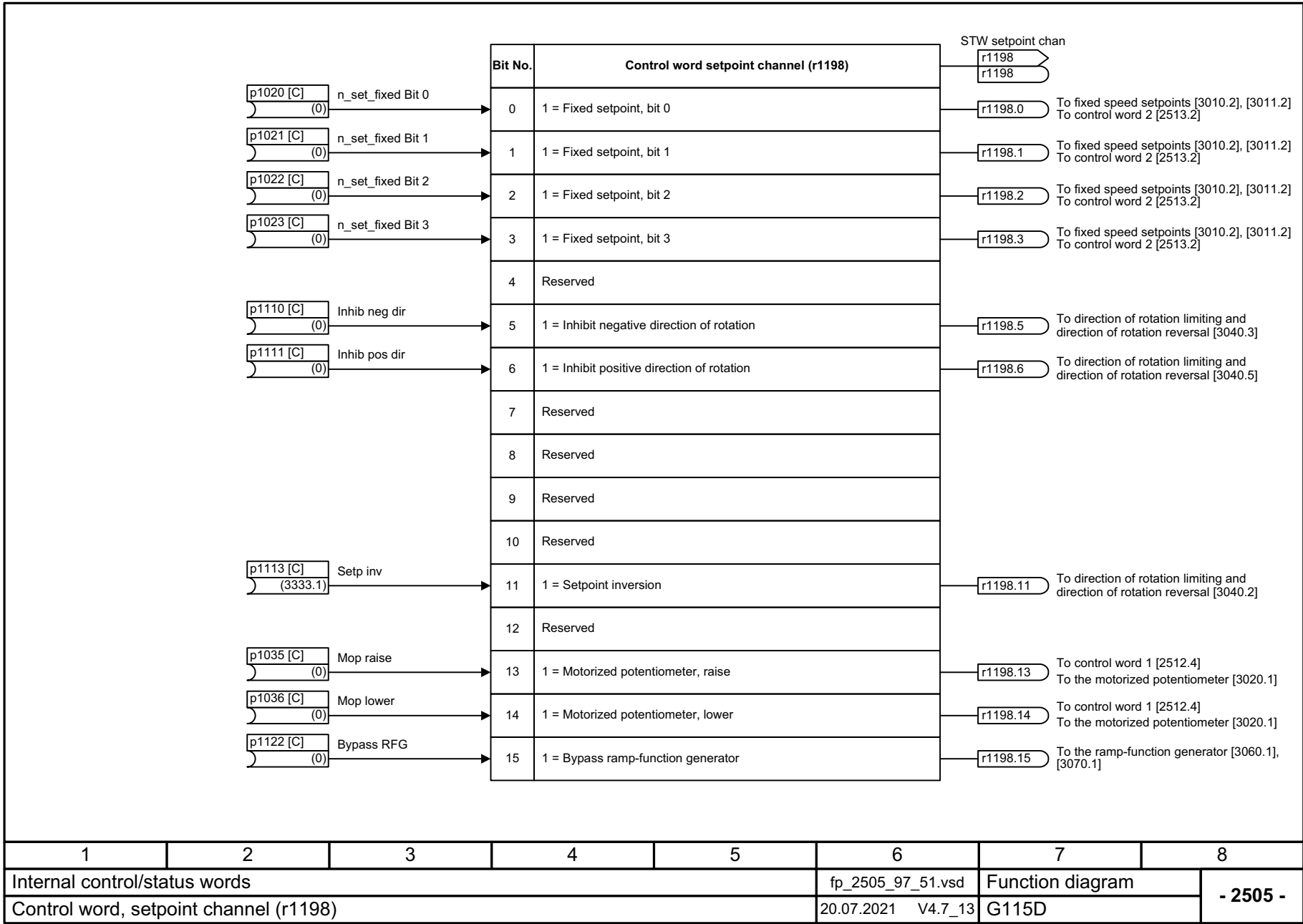
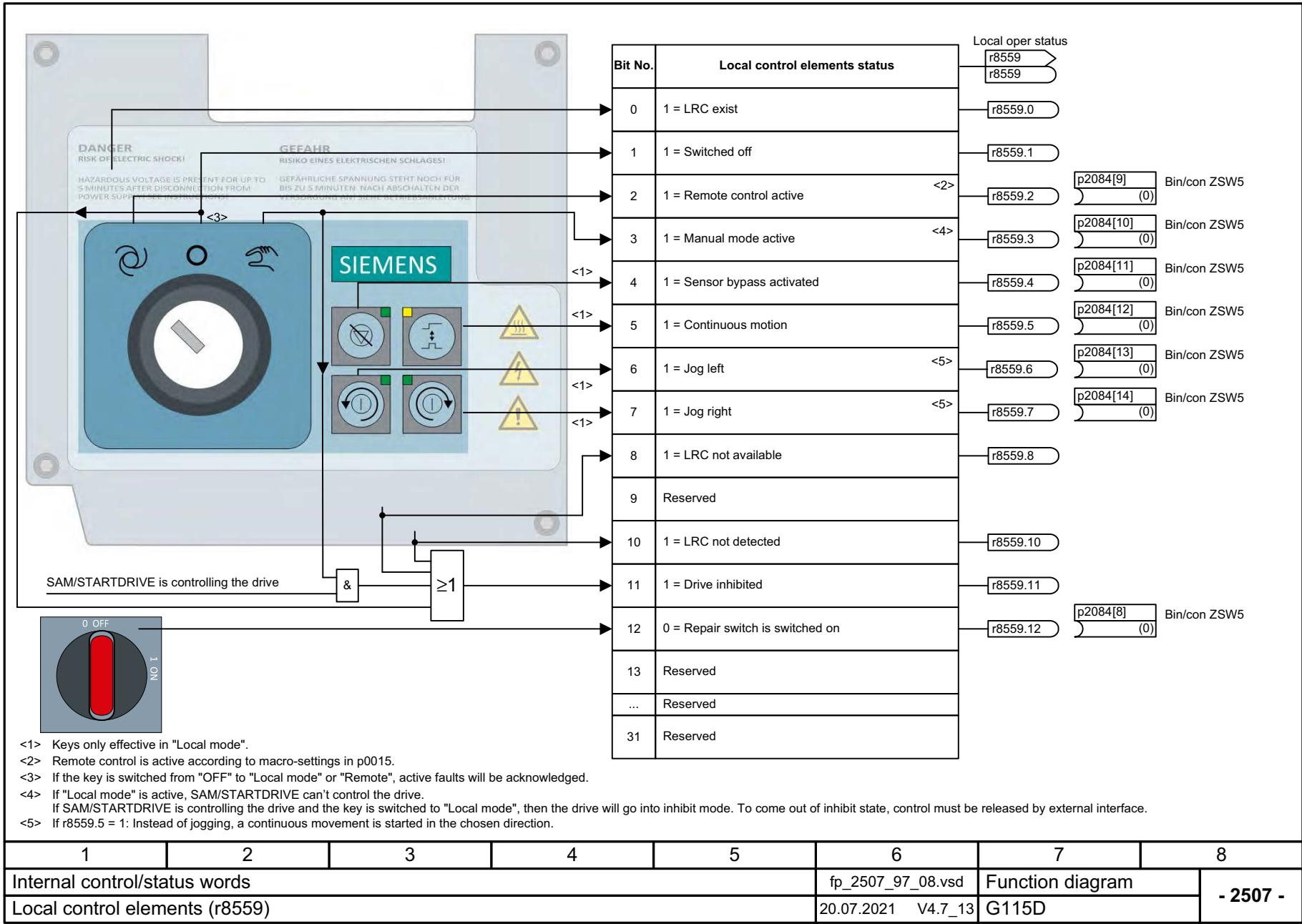
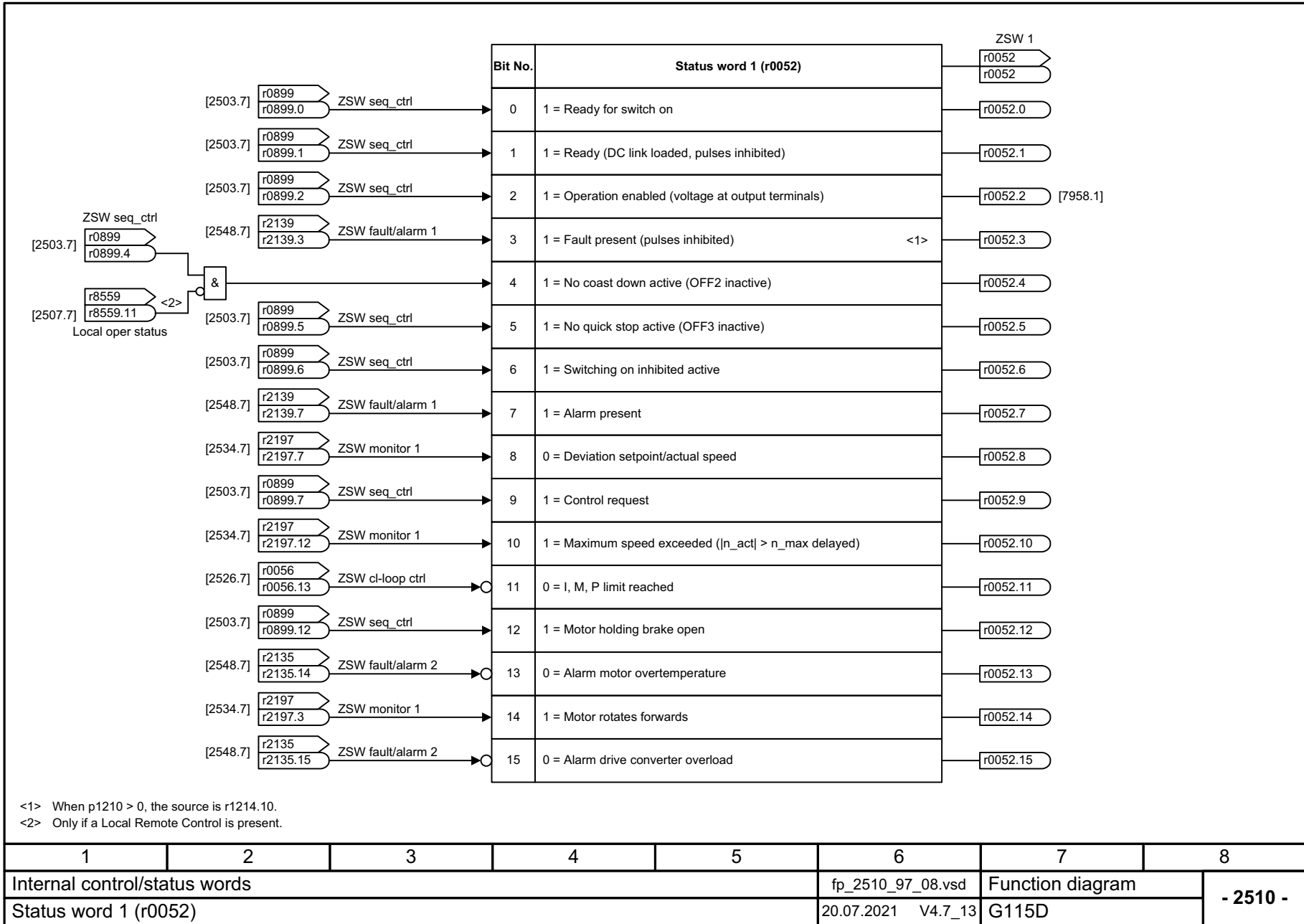

Fig. 3-41 2505 – Control word setpoint channel (r1198)

1	2	3	4	5	6	7	8
Internal control/status words					fp_2505_97_51.vsd	Function diagram	
Control word, setpoint channel (r1198)					20.07.2021 V4.7_13	G115D	
- 2505 -							

Fig. 3-42 2507 – status word key status (r8559)





1	2	3	4	5	6	7	8
Internal control/status words					fp_2510_97_08.vsd	Function diagram	
Status word 1 (r0052)					20.07.2021 V4.7_13	G115D	
- 2510 -							

Fig. 3-43 2510 – Status word 1 (r0052)

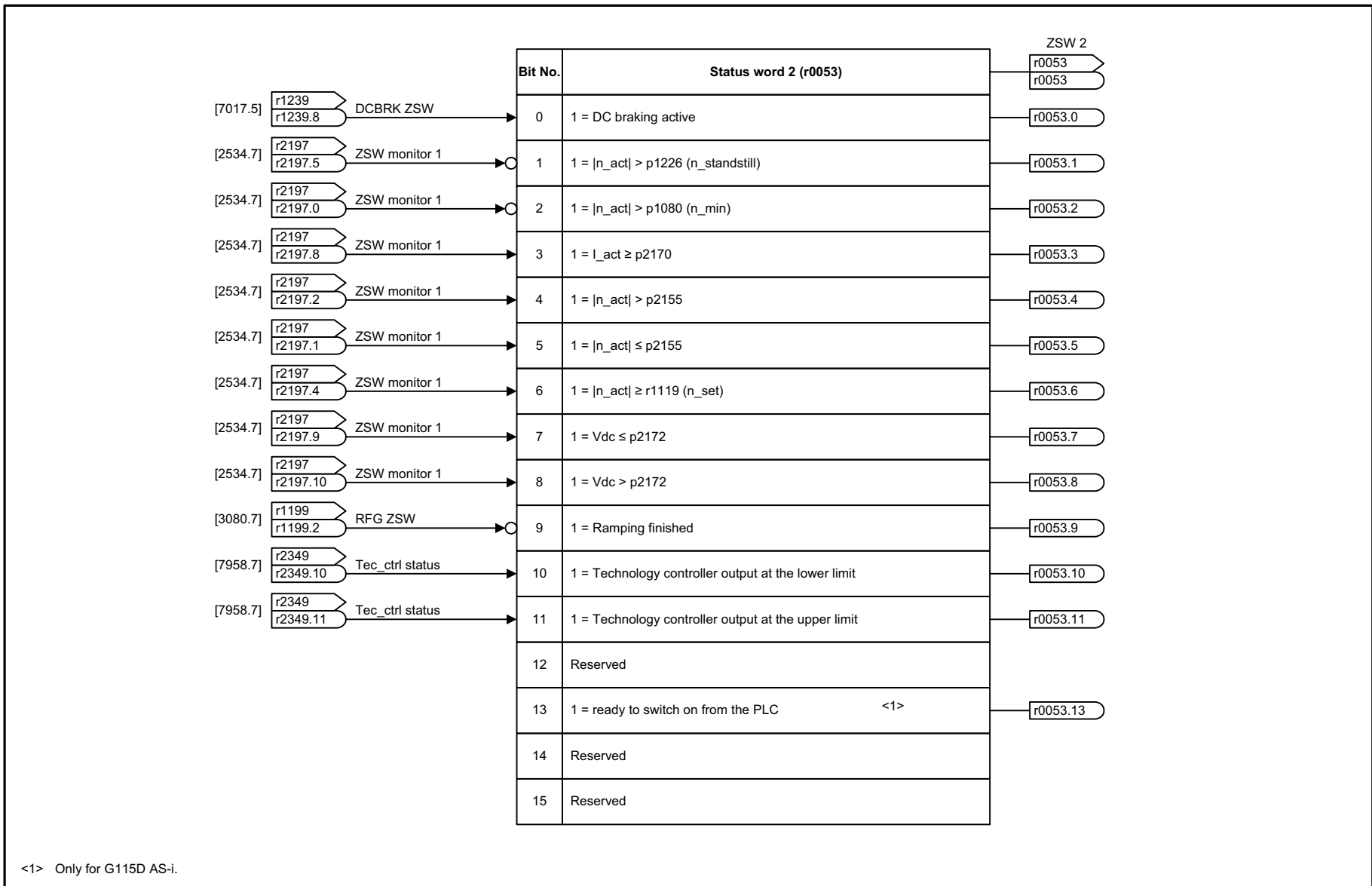

1	2	3	4	5	6	7	8
Internal control/status words					fp_2511_97_70.vsd	Function diagram	
Status word 2 (r0053)					20.07.2021 V4.7_13	G115D	

- 2511 -

Fig. 3-44 2511 – Status word 2 (r0053)

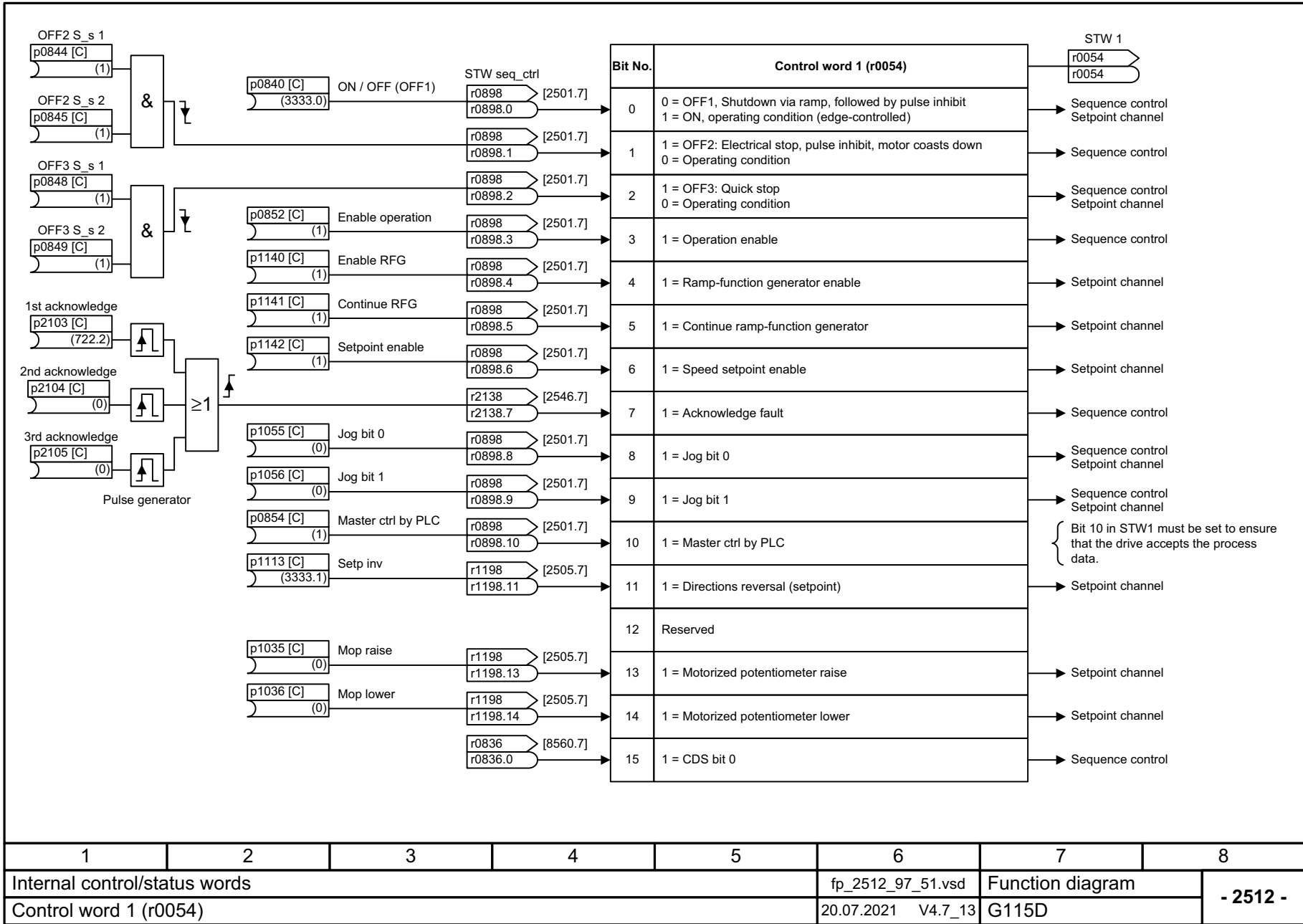
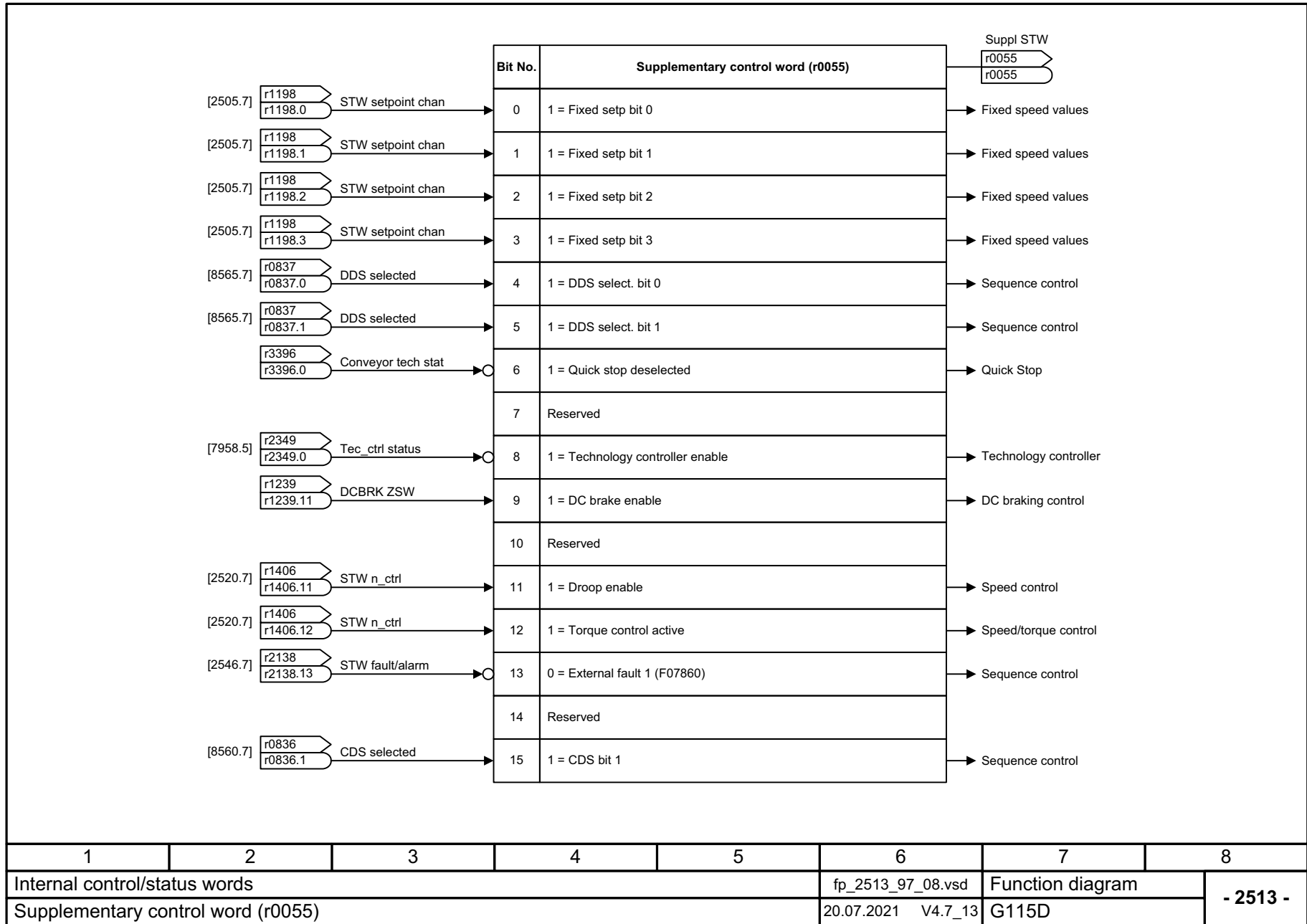

Fig. 3-45 2512 – Control word 1 (r0054)

1	2	3	4	5	6	7	8
Internal control/status words					fp_2512_97_51.vsd	Function diagram	
Control word 1 (r0054)					20.07.2021 V4.7_13	G115D	
- 2512 -							

Fig. 3-46 2513 – Supplementary control word (r0055)



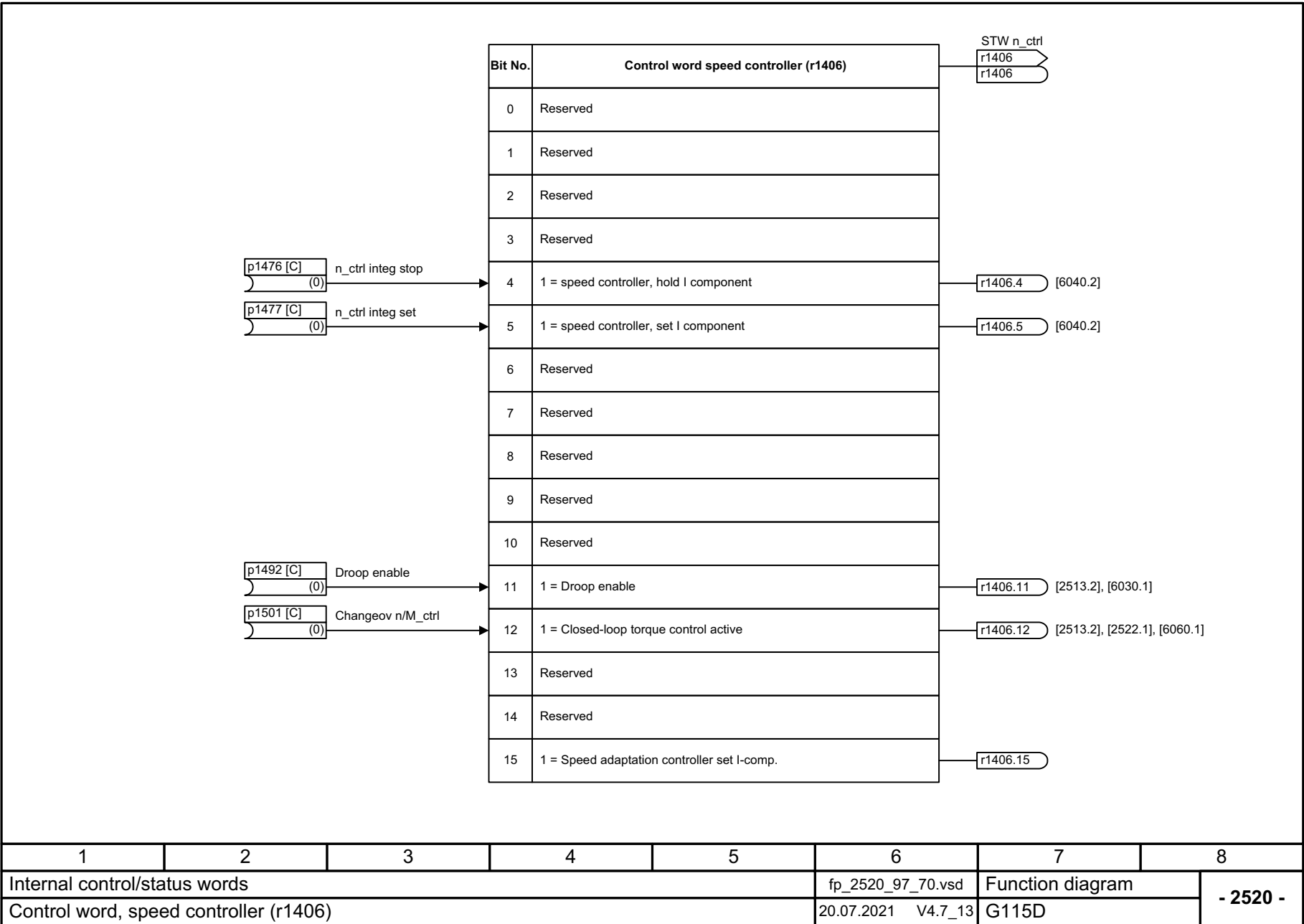
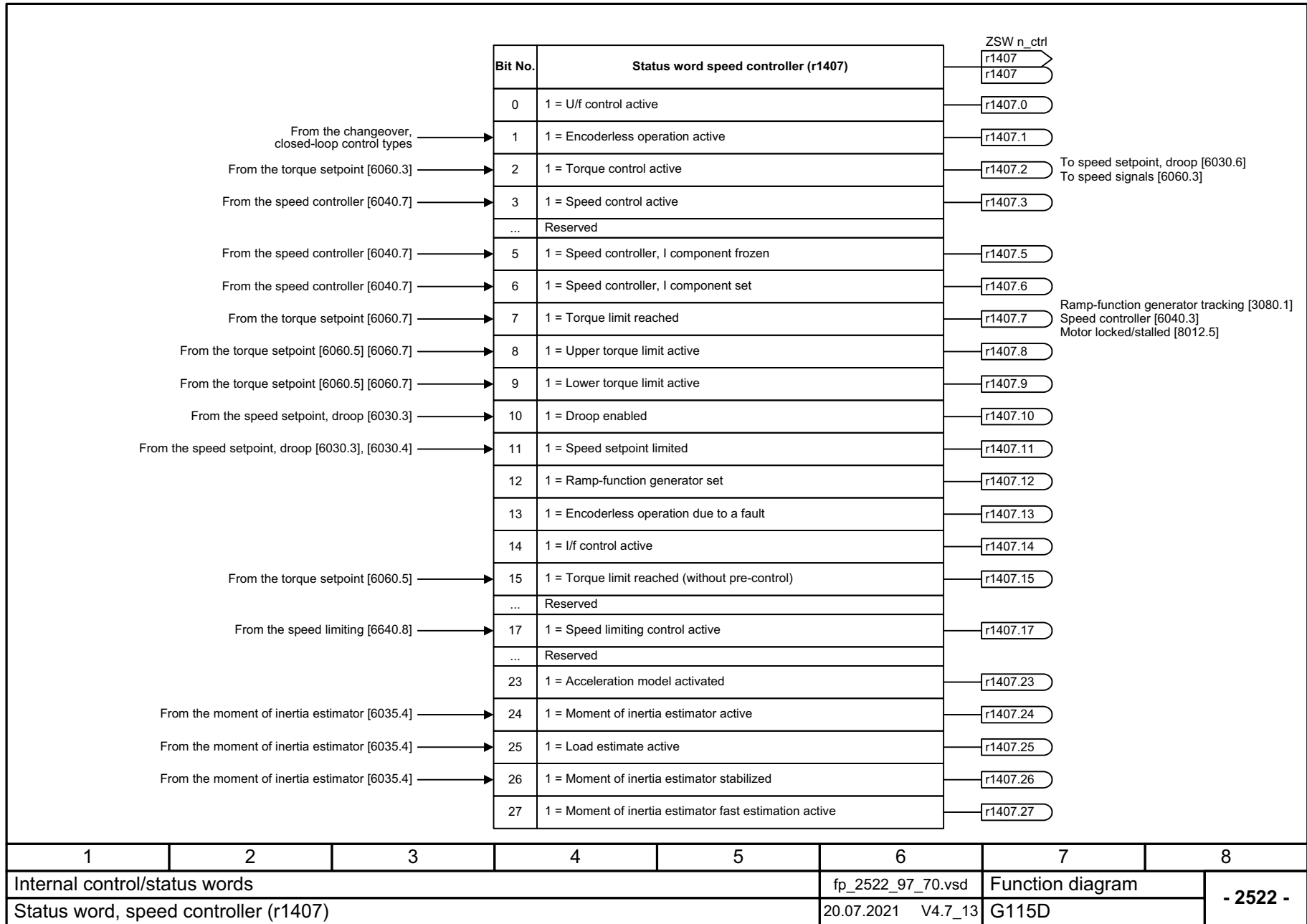

Fig. 3-47 2520 – Control word speed controller (r1406)

1	2	3	4	5	6	7	8
Internal control/status words					fp_2520_97_70.vsd	Function diagram	
Control word, speed controller (r1406)					20.07.2021 V4.7_13	G115D	
- 2520 -							

Fig. 3-48 2522 – Status word speed controller (r1407)



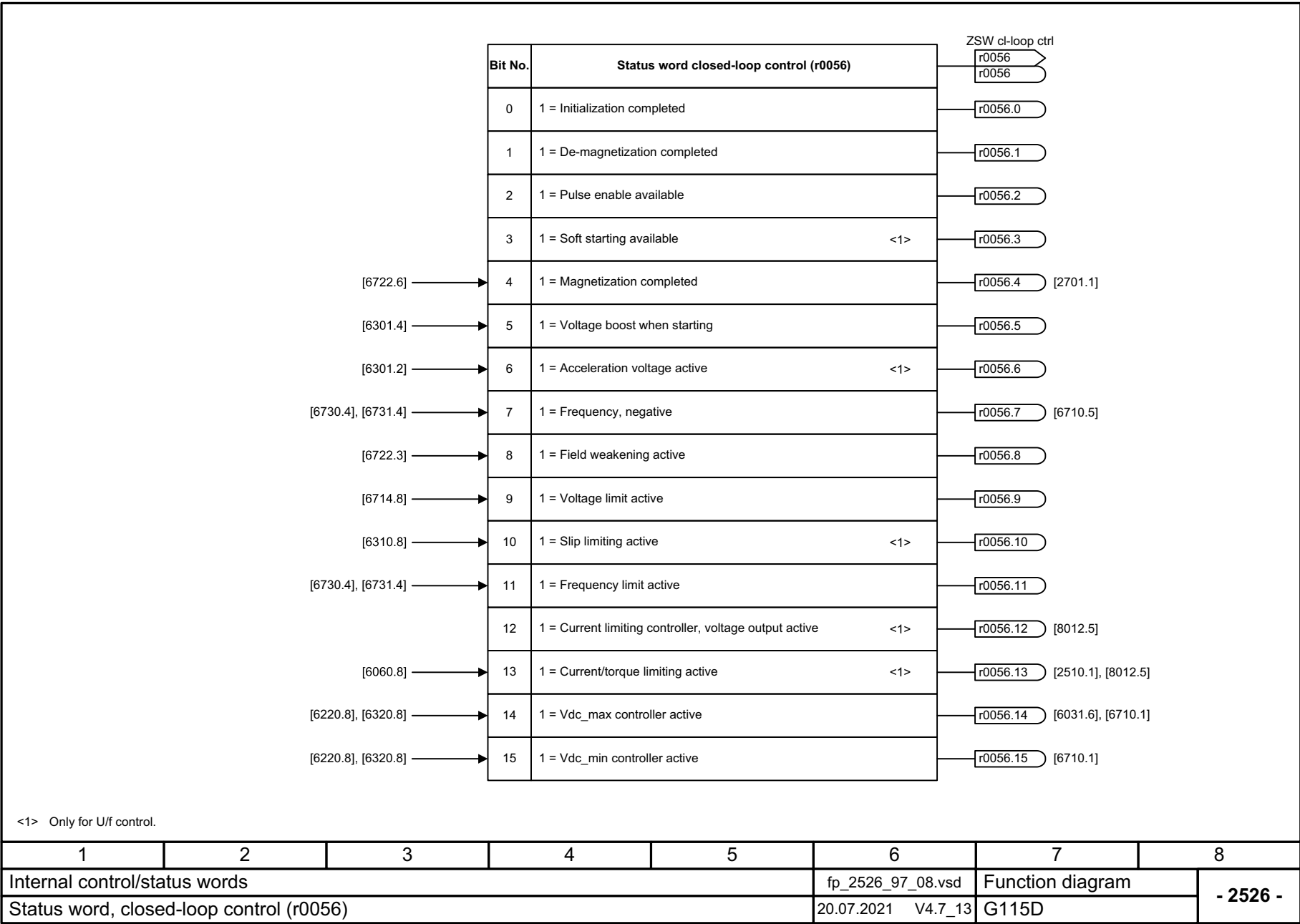

Fig. 3-49 2526 – Status word closed-loop control (r0056)

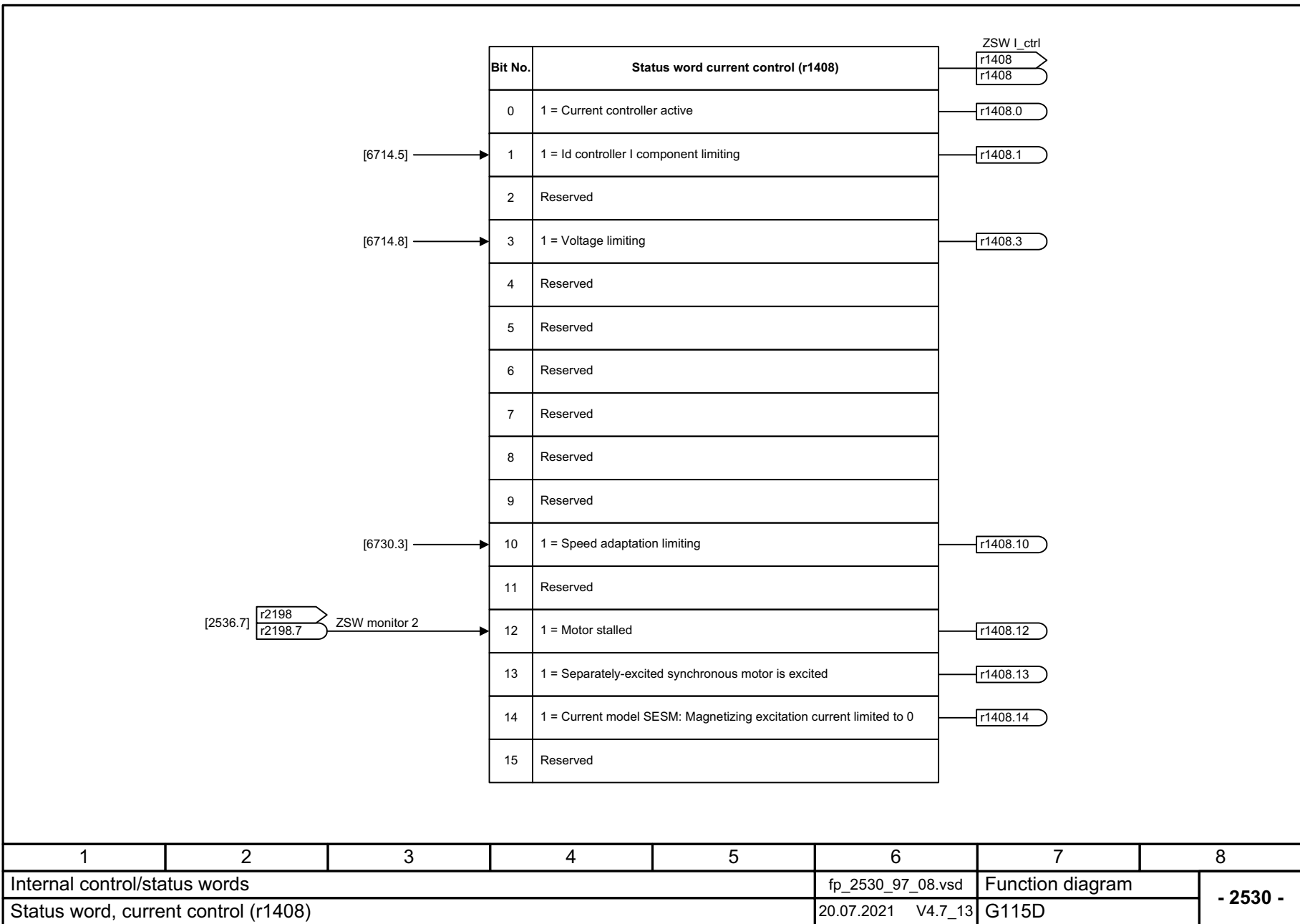

Fig. 3-50 2530 – Status word current control (r1408)

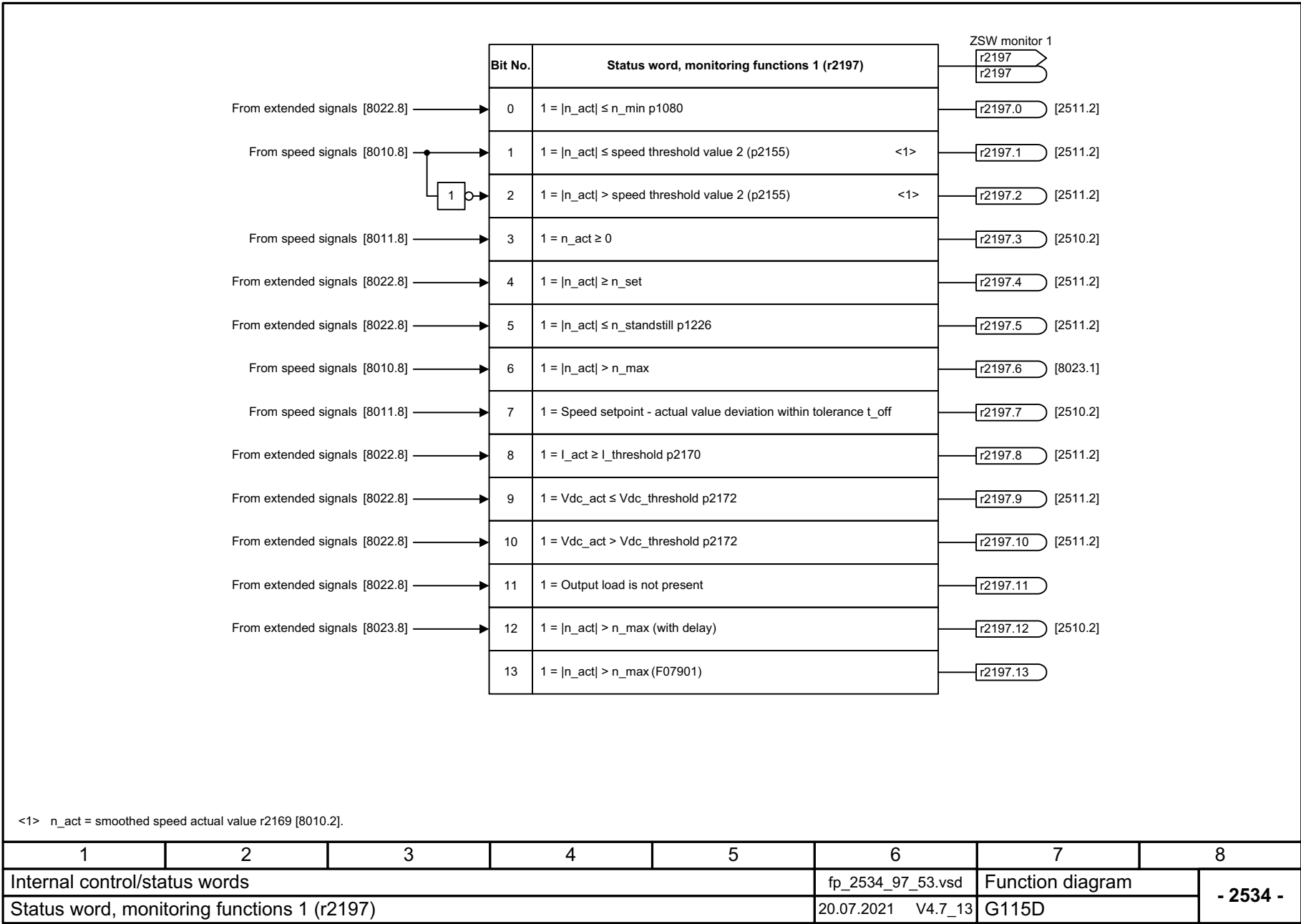
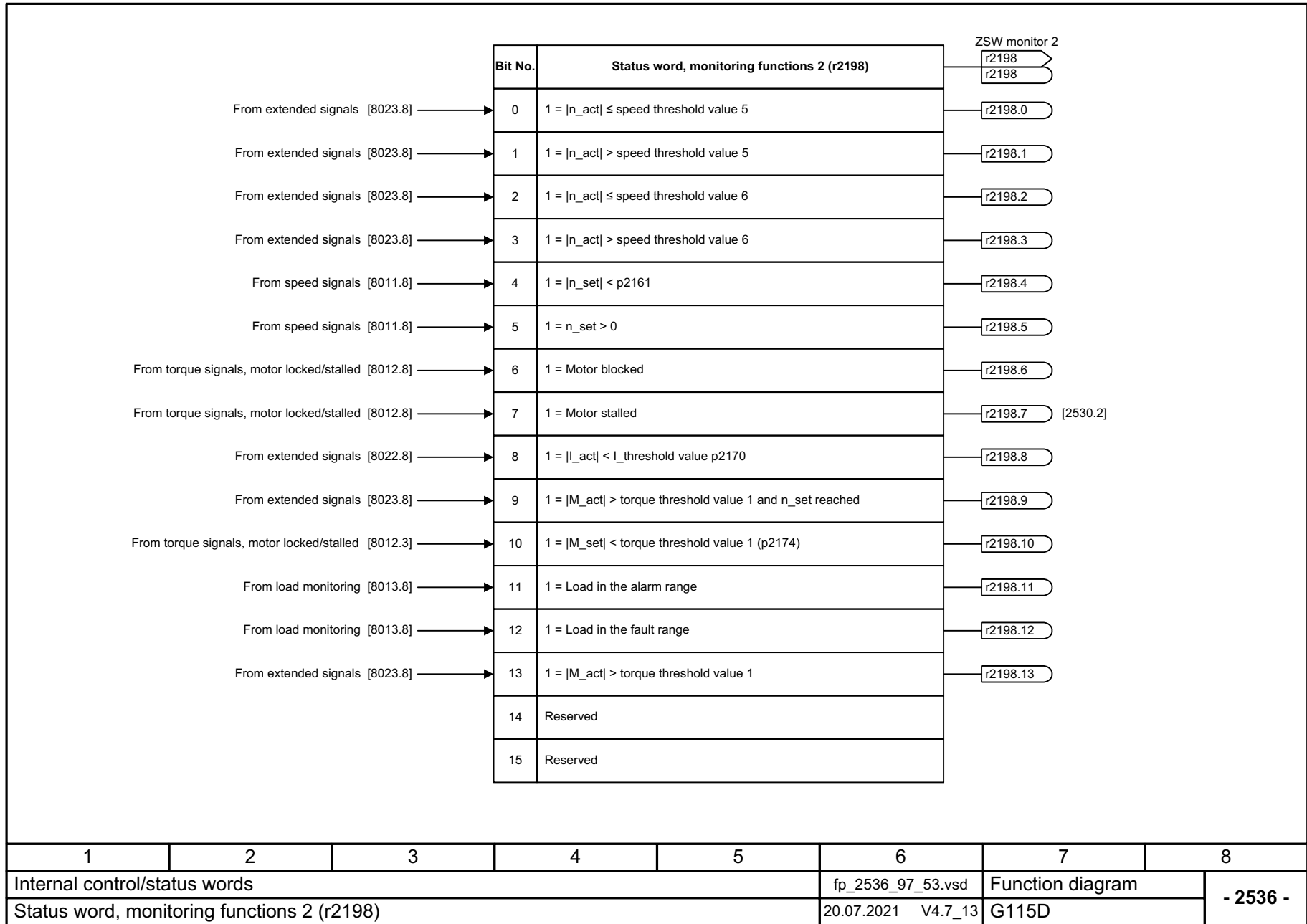

Fig. 3-51 2534 – Status word monitoring functions 1 (r2197)

Fig. 3-52 2536 – Status word monitoring functions 2 (r2198)



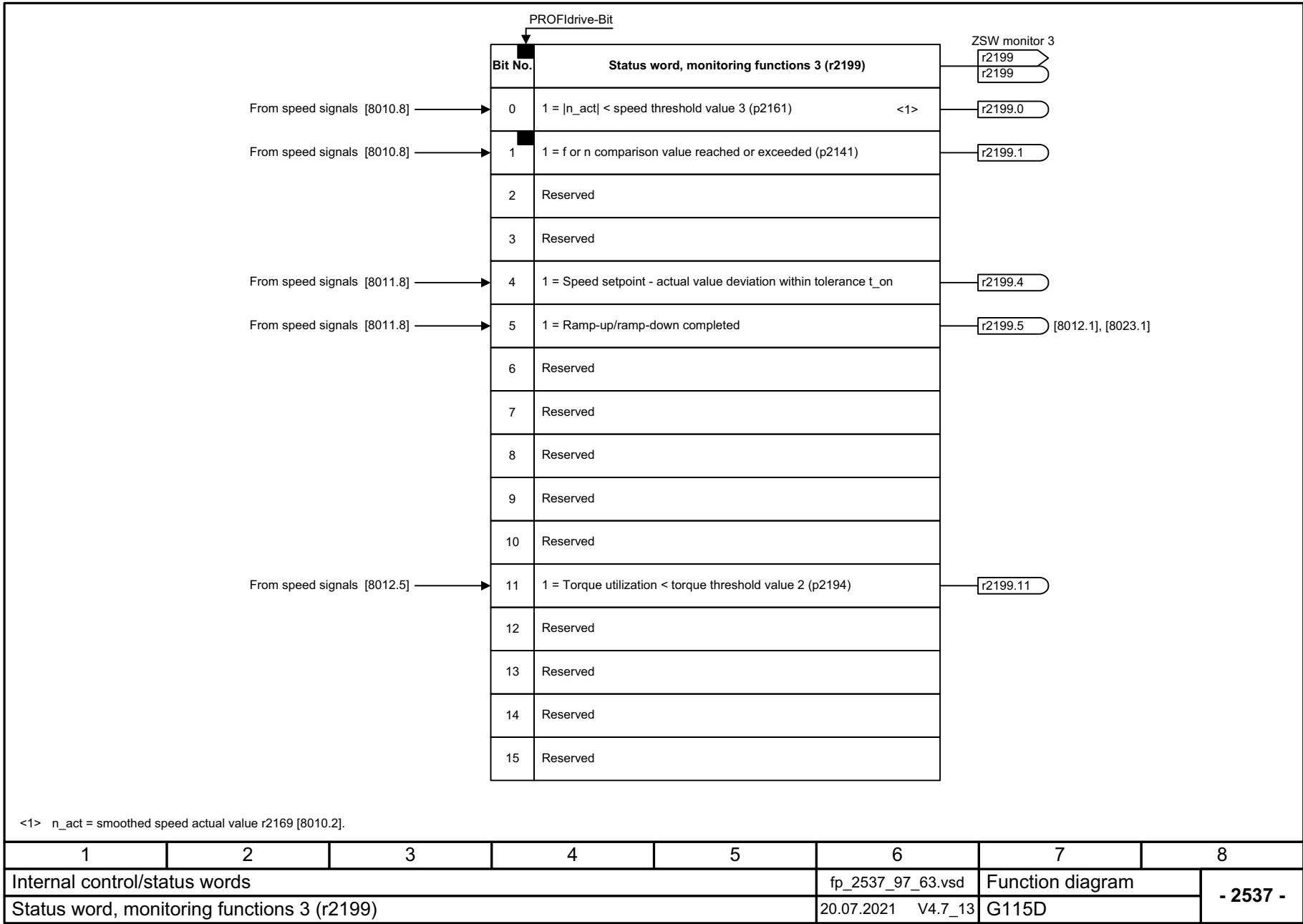

Fig. 3-53 2537 – Status word monitoring functions 3 (r2199)

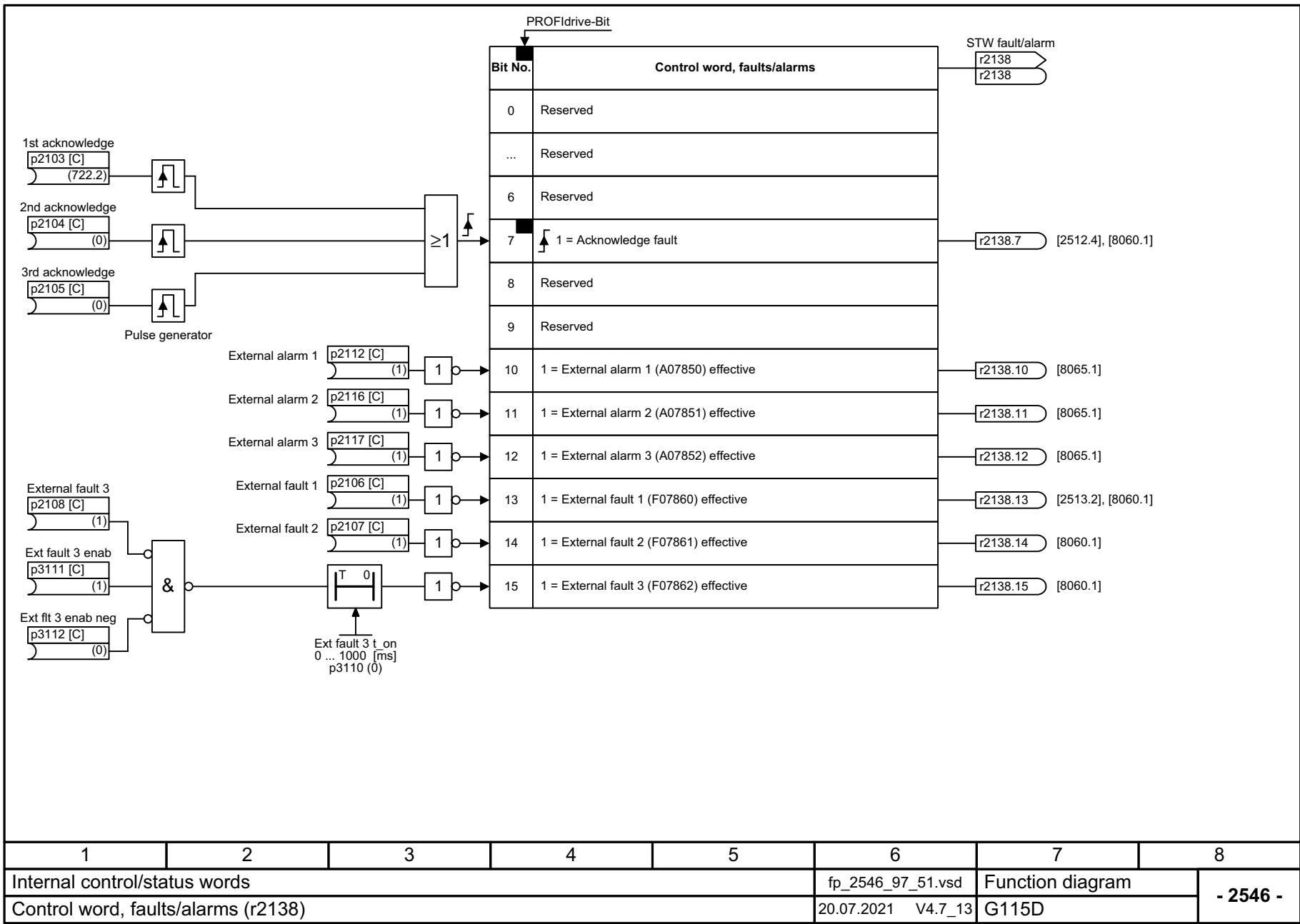

Fig. 3-54 2546 – Control word faults/alarms (r2138)

1	2	3	4	5	6	7	8
Internal control/status words					fp_2546_97_51.vsd	Function diagram	
Control word, faults/alarms (r2138)					20.07.2021 V4.7_13	G115D	
- 2546 -							

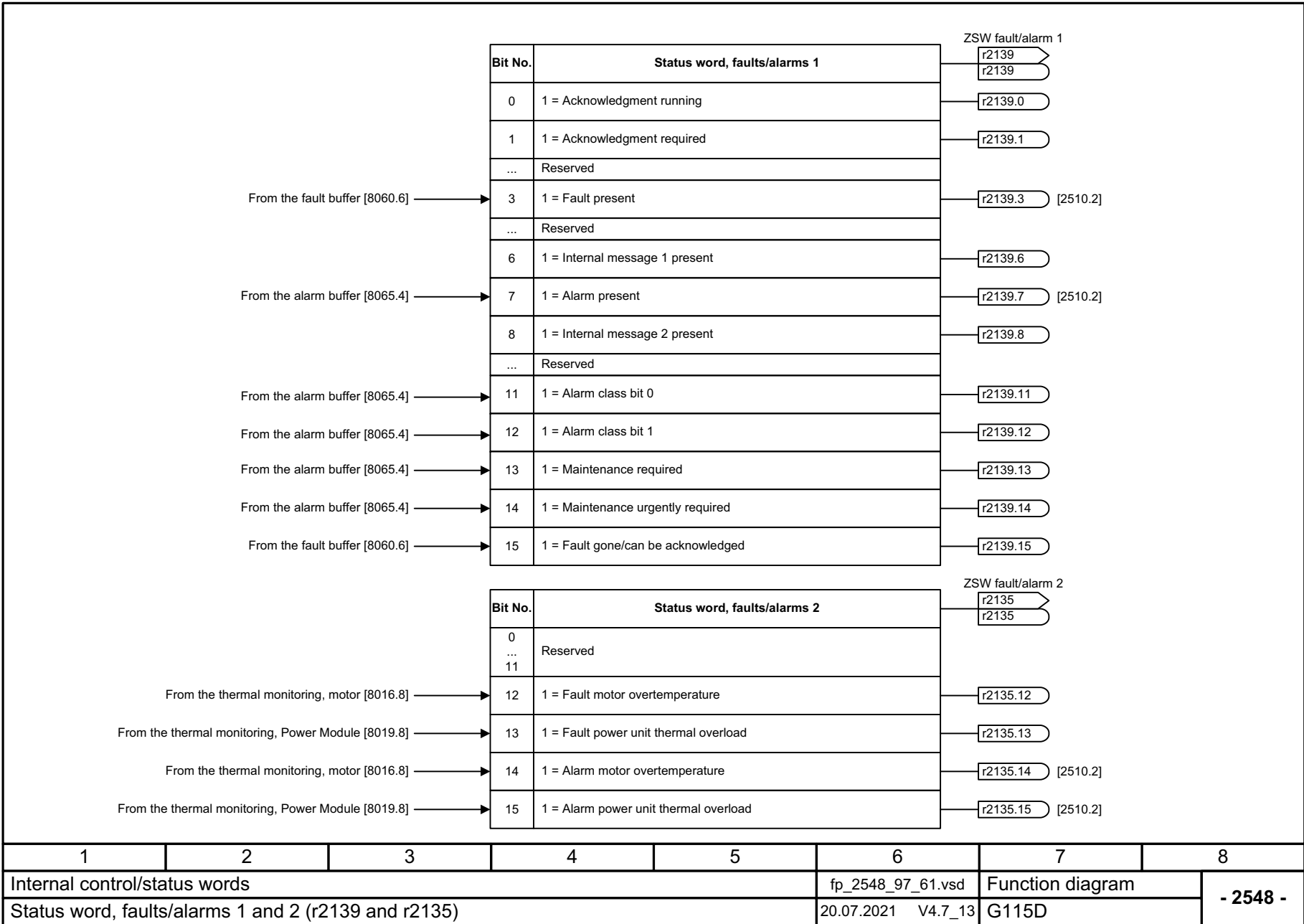
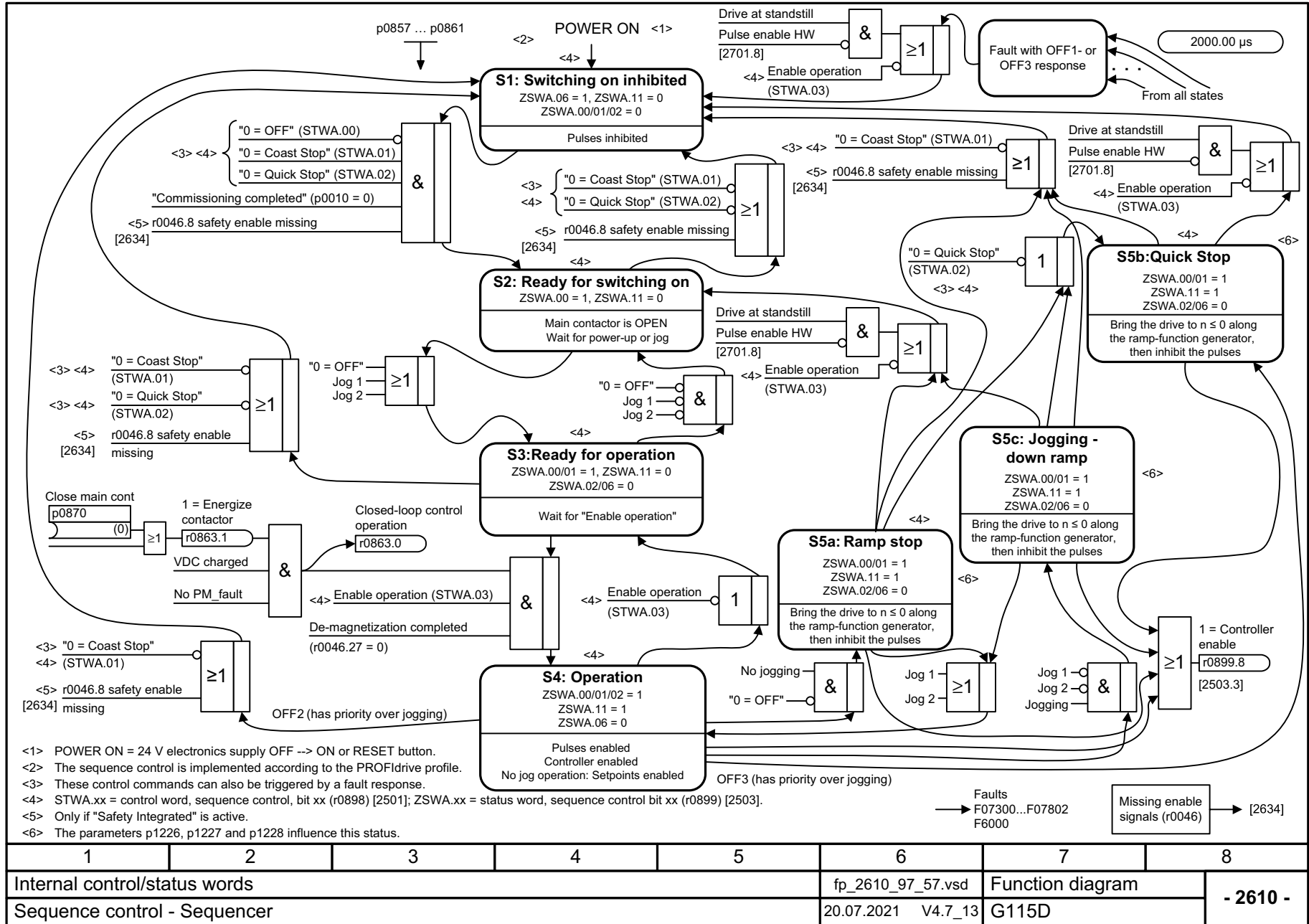
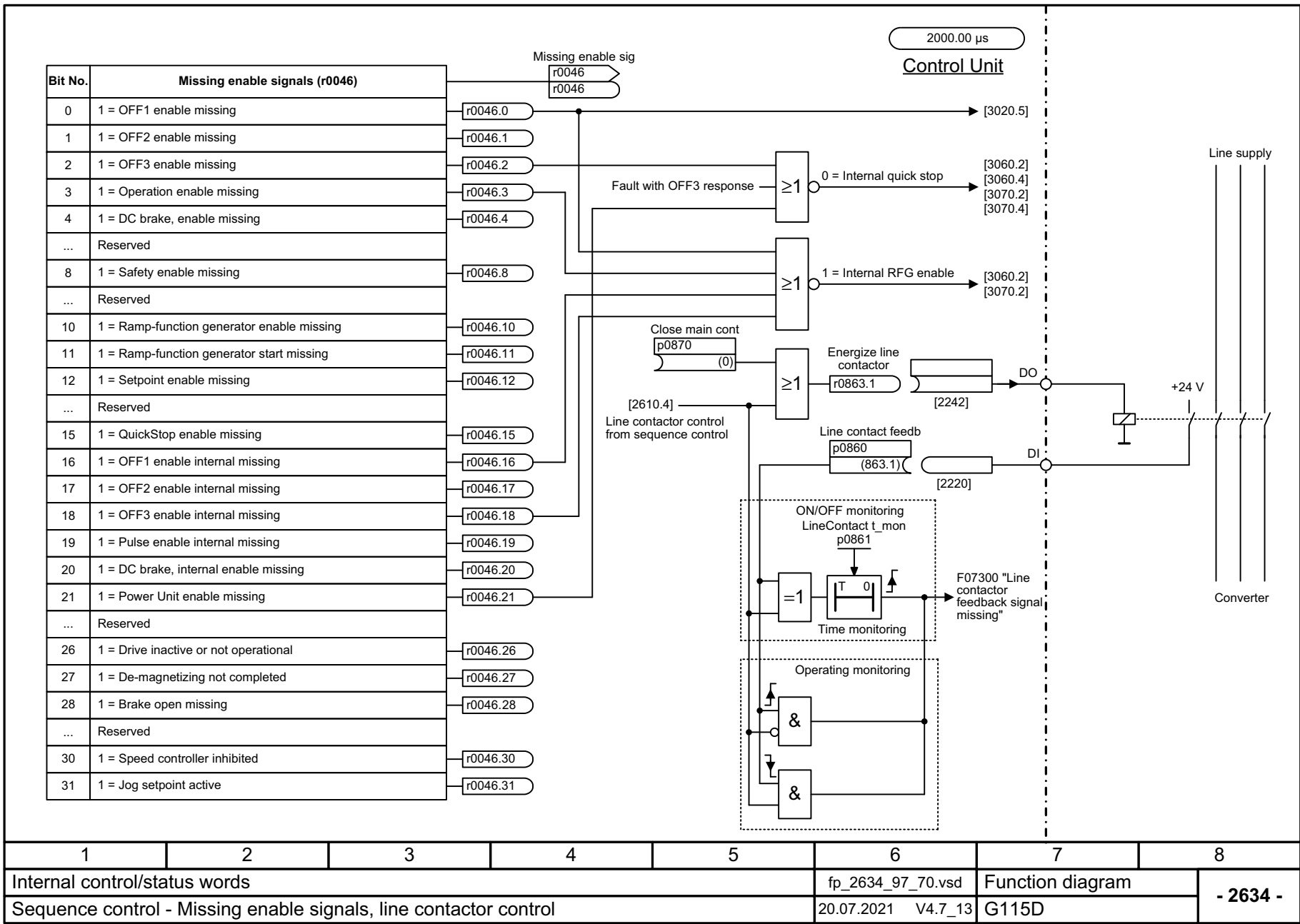

Fig. 3-55 2548 – Status word faults/alarms 1 and 2 (r2139 and r2135)

Fig. 3-56 2610 – Sequence control - Sequencer





1	2	3	4	5	6	7	8
Internal control/status words					fp_2634_97_70.vsd	Function diagram	
Sequence control - Missing enable signals, line contactor control					20.07.2021 V4.7_13	G115D	
- 2634 -							

Fig. 3-57 2634 – Sequence control - missing enable signals, line contactor control

3.8 Brake control

Function diagrams

2701 – Basic brake control

562

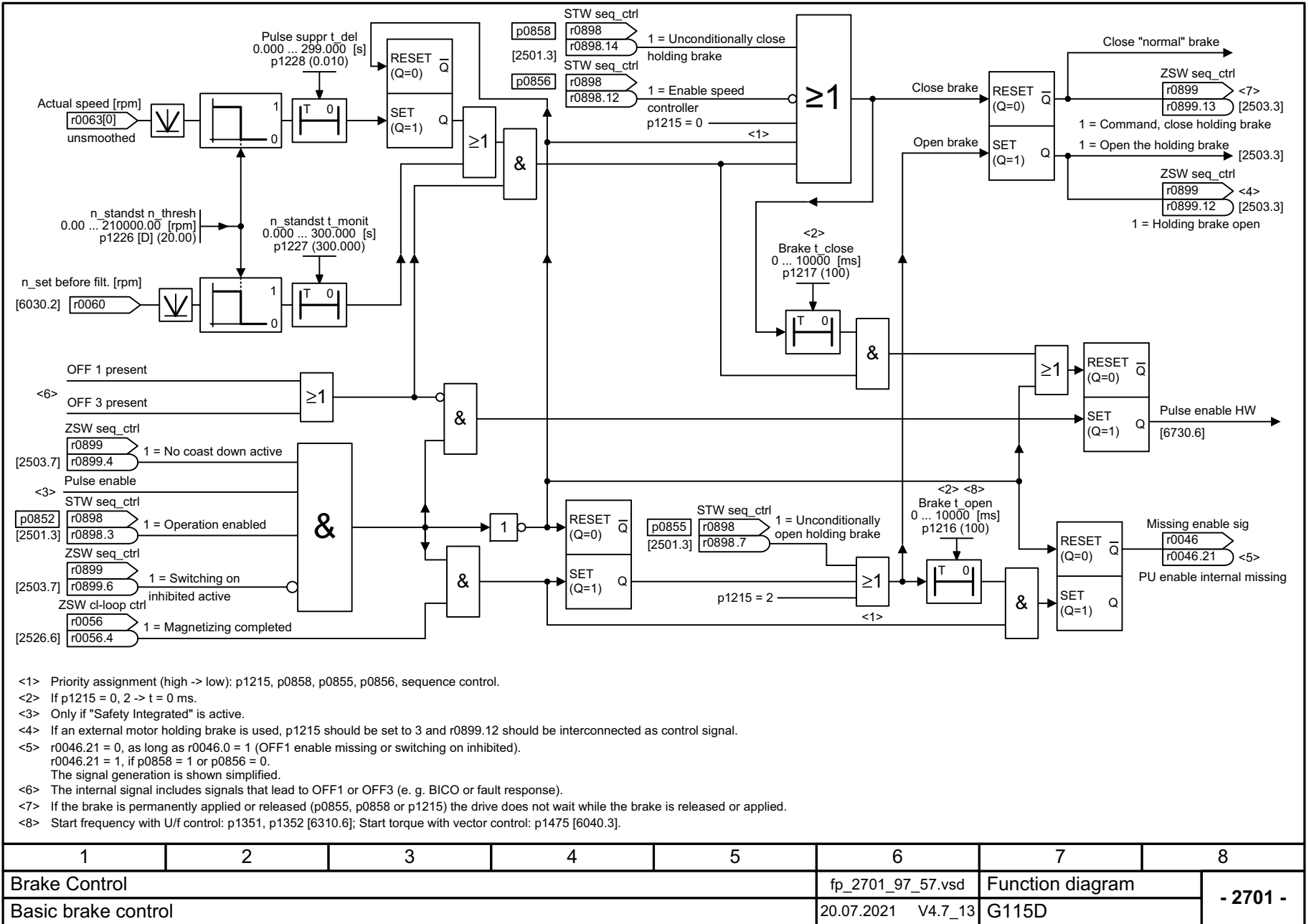

3.9 Safety Integrated Basic Functions

Function diagrams

2800 – Parameter manager	564
2802 – Monitoring functions and faults/alarms	565
2804 – Status words	566
2810 – STO (Safe Torque Off)	567
2813 – F-DI (Fail-safe Digital Input)	568

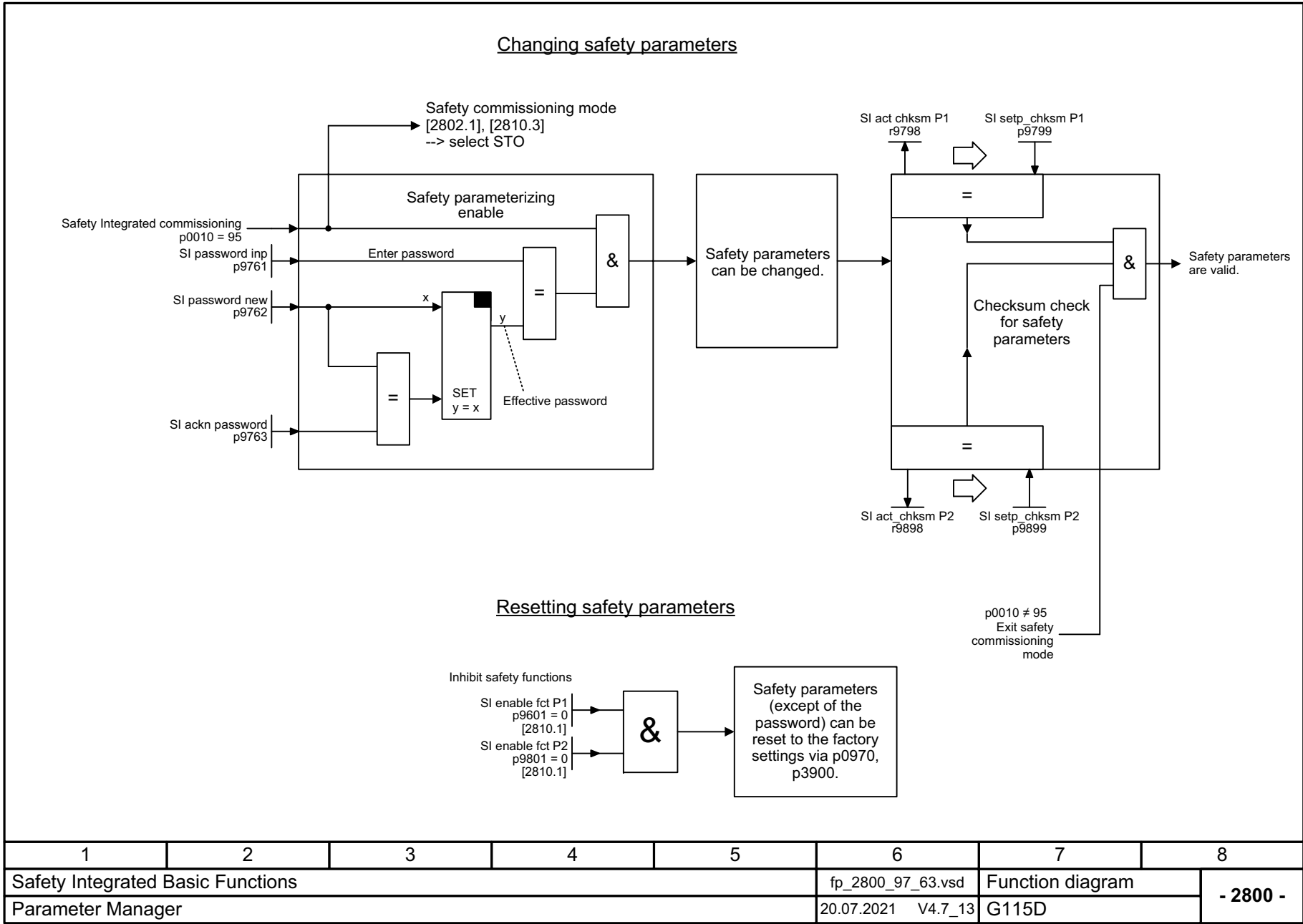
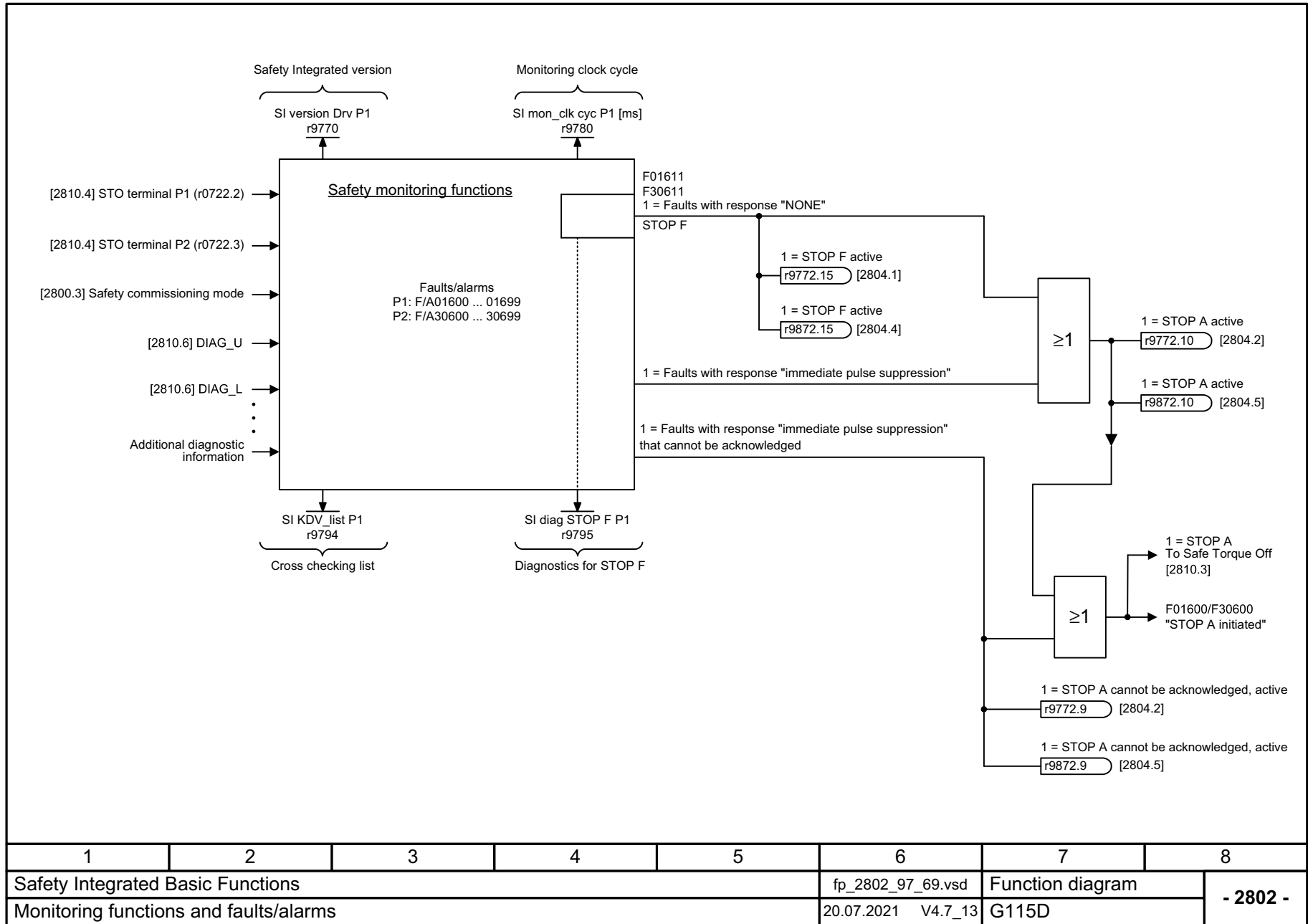

Fig. 3-59 2800 – Parameter manager

1	2	3	4	5	6	7	8
Safety Integrated Basic Functions					fp_2800_97_63.vsd	Function diagram	
Parameter Manager					20.07.2021 V4.7_13	G115D	
							- 2800 -

Fig. 3-60 2802 – Monitoring functions and faults/alarms



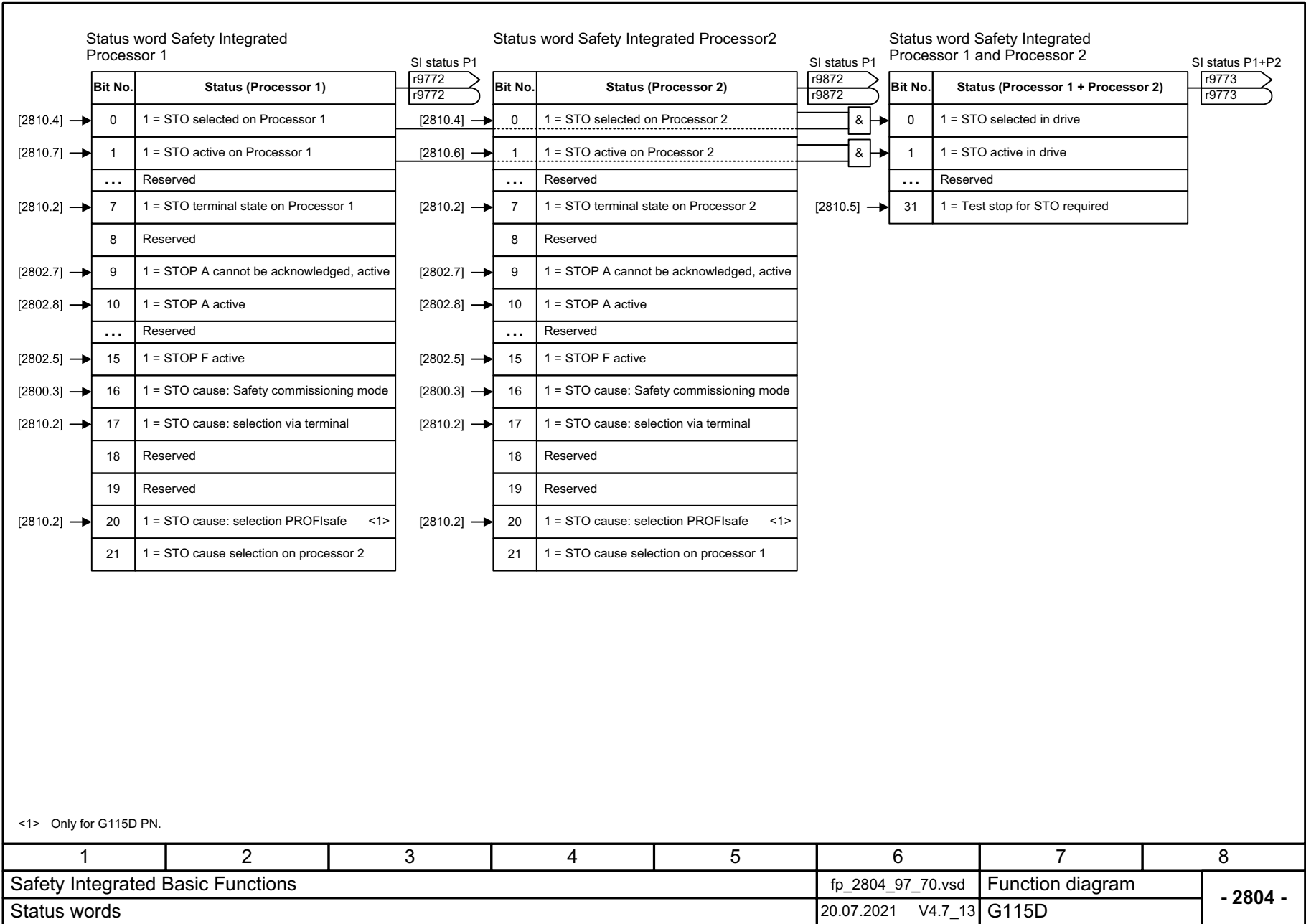
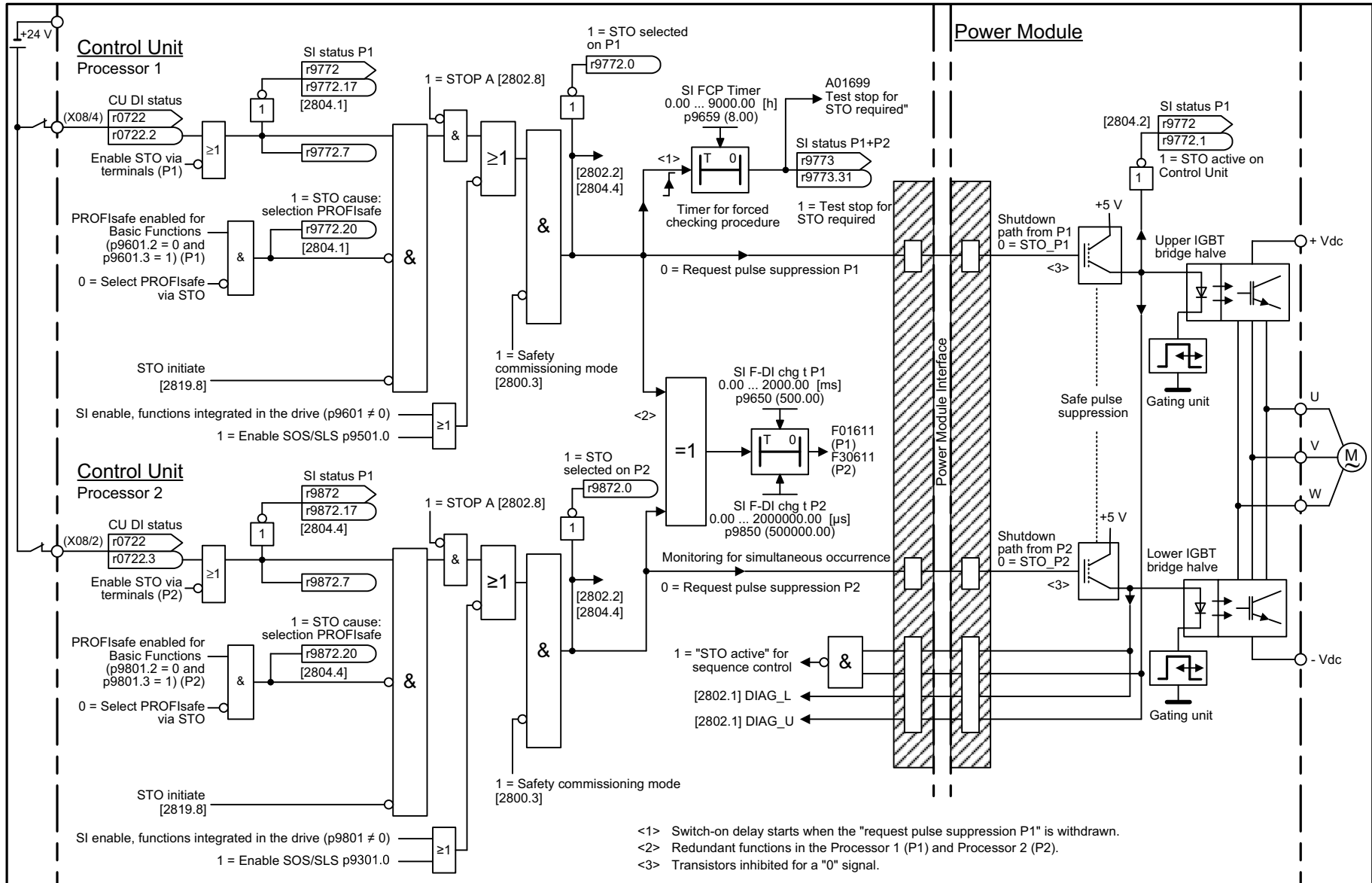

Fig. 3-61 2804 – Status words

Fig. 3-62 2810 - STO (Safe Torque Off)



1	2	3	4	5	6	7	8
Safety Integrated Basic Functions					fp_2810_97_70.vsd	Function diagram	
STO (Safe Torque Off)					20.07.2021 V4.7_13	G115D	

- 2810 -

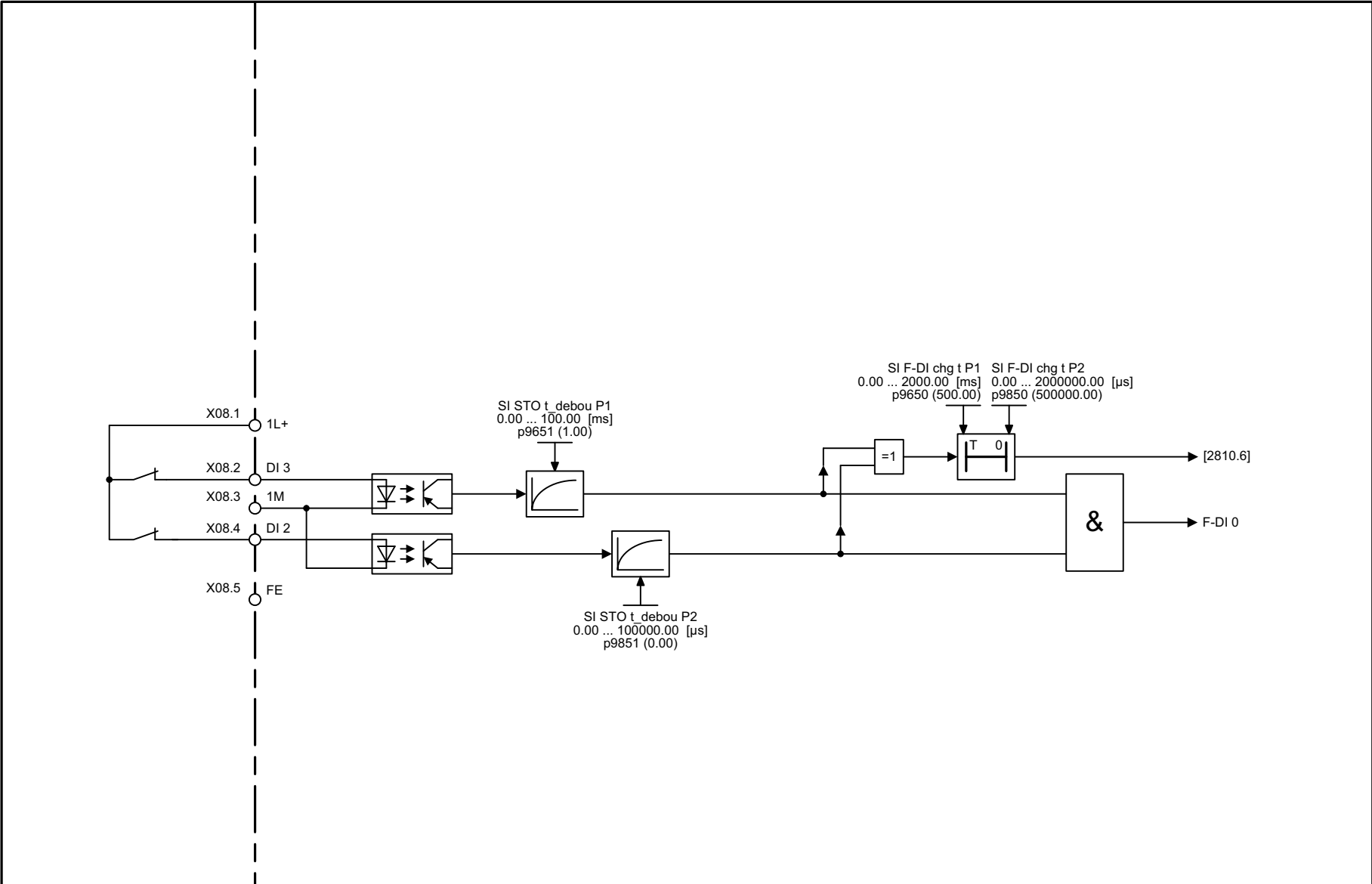

Fig. 3-63 2813 – F-DI (Fail-safe Digital Input)

1	2	3	4	5	6	7	8
Safety Integrated Basic Functions					fp_2813_97_70.vsd	Function diagram	
F-DI (Fail-safe Digital Input)					20.07.2021 V4.7_13	G115D	
- 2813 -							

3.10 Safety Integrated PROFIsafe

Function diagrams

2915 – Standard telegrams	570
2917 – Manufacturer-specific telegrams	571

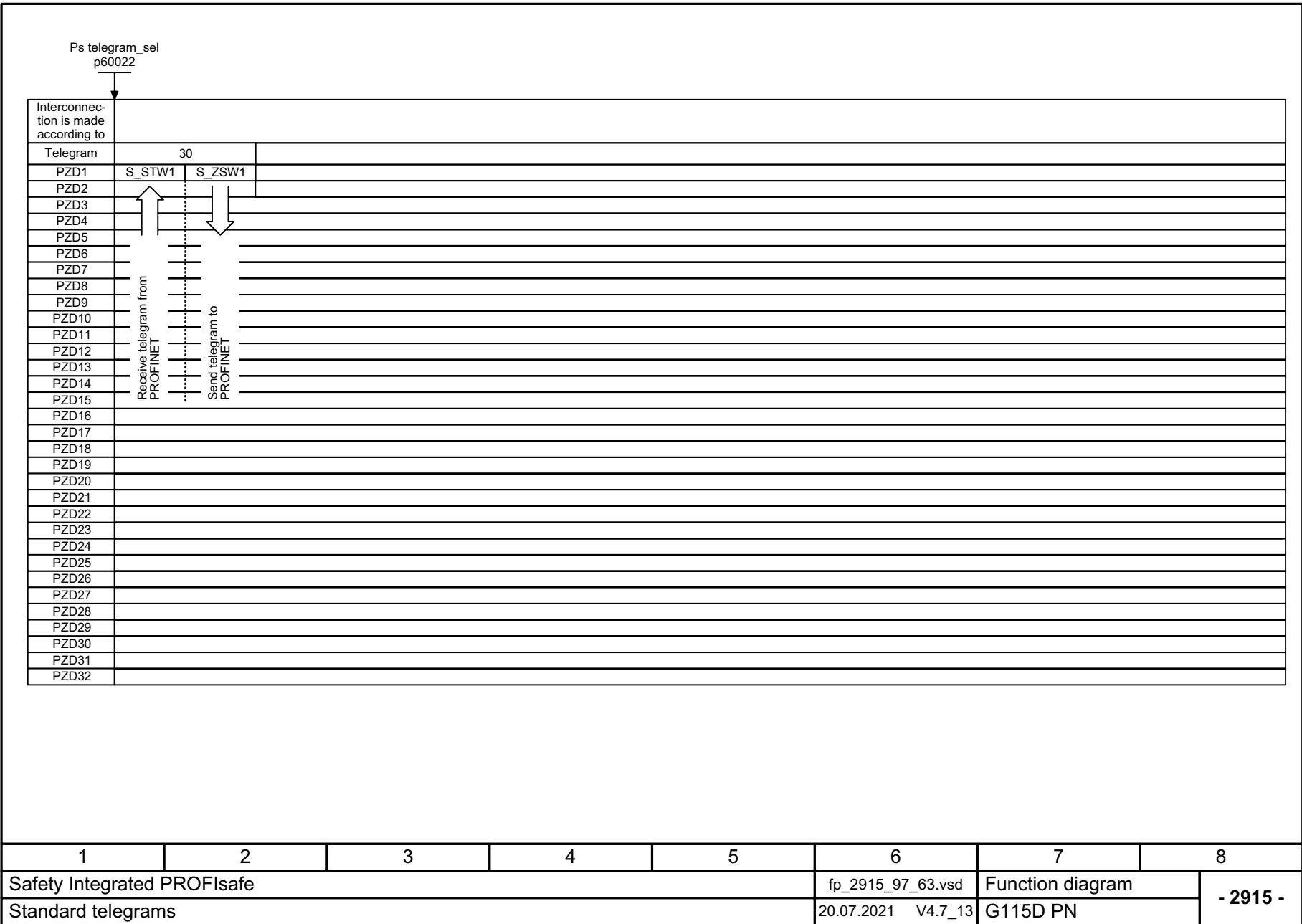

Fig. 3-64 2915 – Standard telegrams

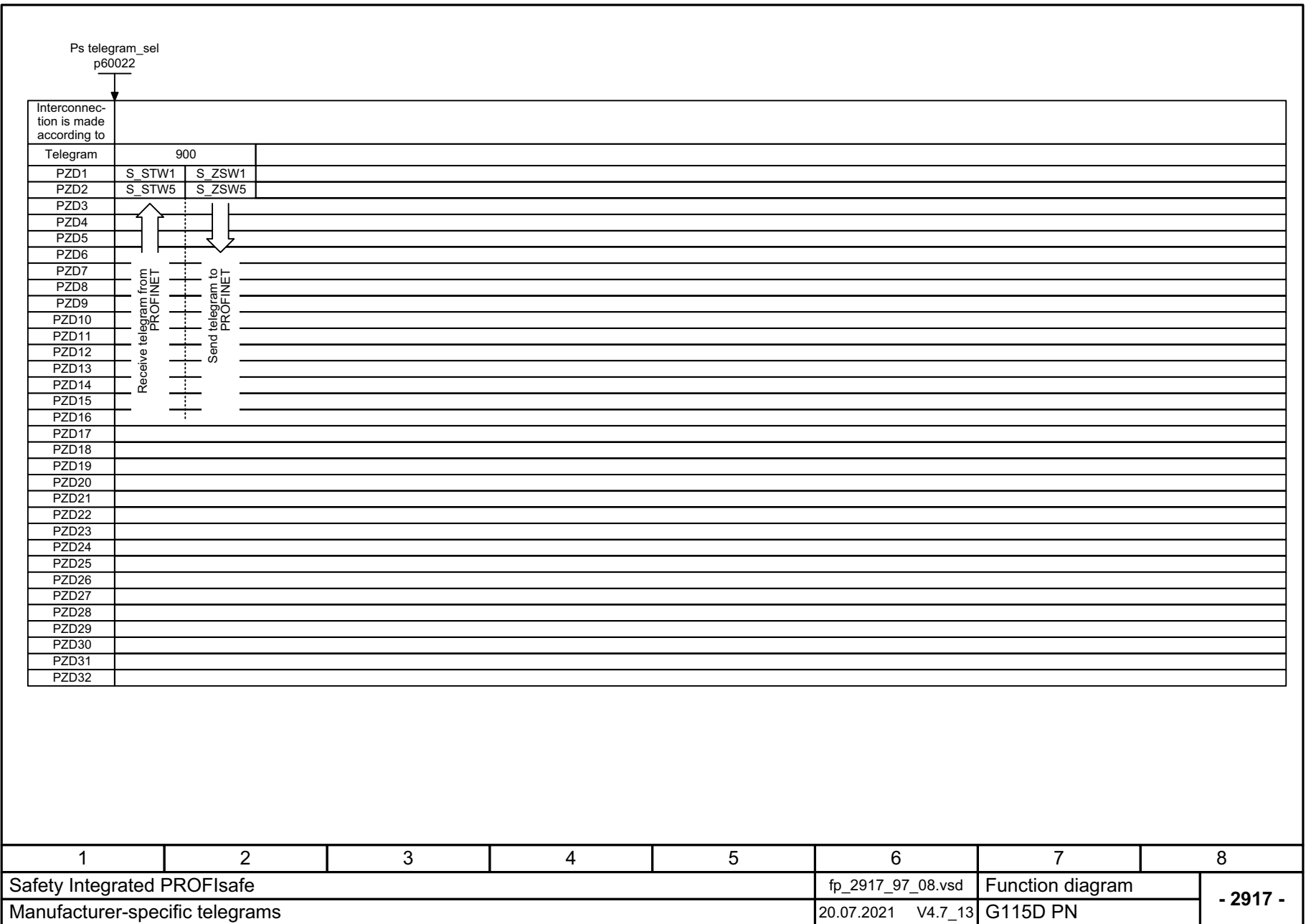

Fig. 3-65 2917 – Manufacturer-specific telegrams

3.11 Setpoint channel

Function diagrams

3001 – Overview	573
3010 – Fixed speed setpoints, binary selection (p1016 = 2)	574
3011 – Fixed speed setpoints, direct selection (p1016 = 1)	575
3020 – Motorized potentiometer	576
3030 – Main/supplementary setpoint, setpoint scaling, jogging	577
3040 – Direction limitation and direction reversal	578
3050 – Skip frequency bands and speed limitations	579
3060 – Basic ramp-function generator	580
3070 – Extended ramp-function generator	581
3080 – Ramp-function generator selection, status word, tracking	582

Fig. 3-66 3001 – Overview

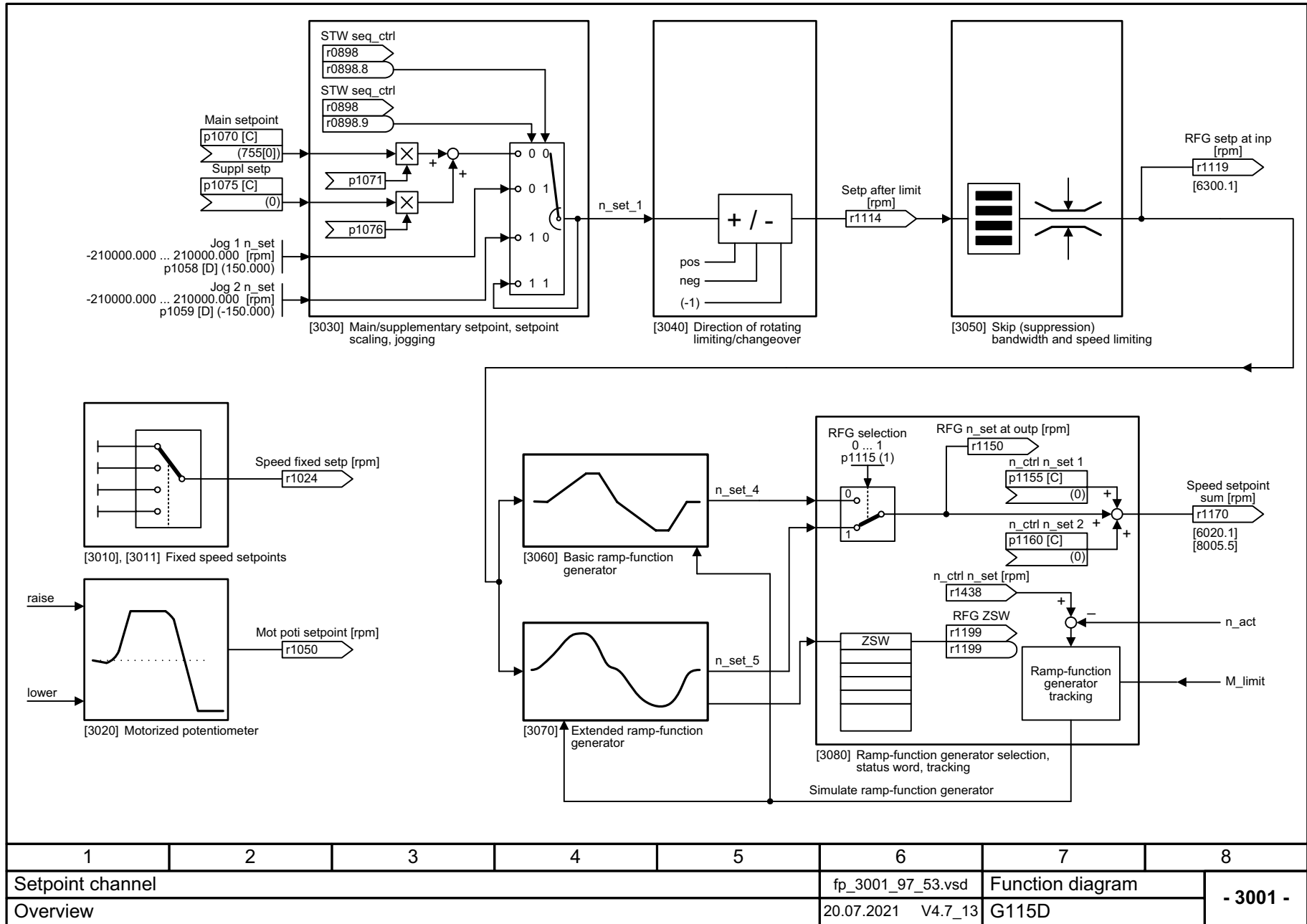

1	2	3	4	5	6	7	8
Setpoint channel					fp_3001_97_53.vsd	Function diagram	
Overview					20.07.2021 V4.7_13	G115D	
							- 3001 -

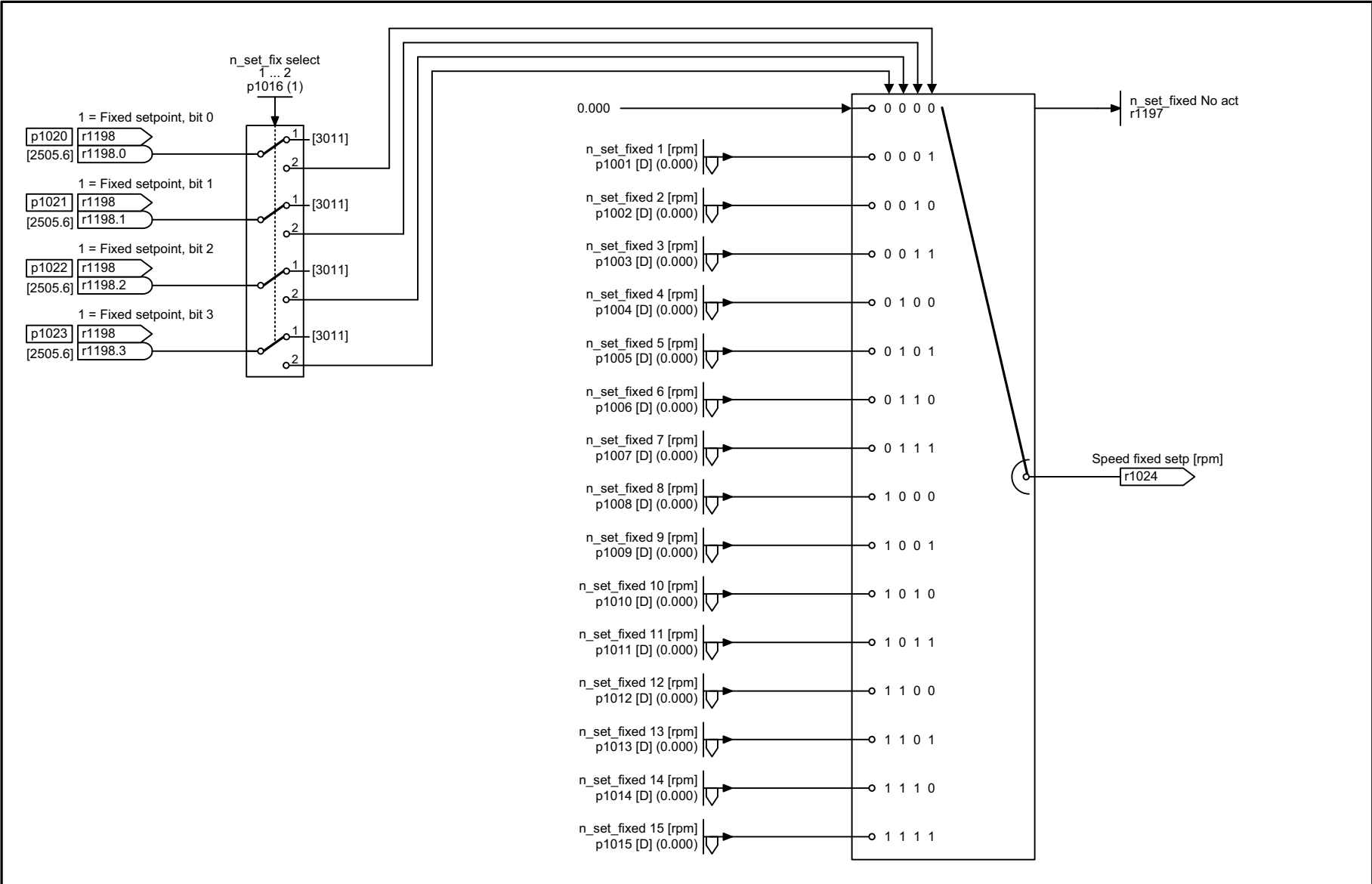

1	2	3	4	5	6	7	8
Setpoint channel					fp_3010_97_51.vsd	Function diagram	
Fixed speed setpoints, binary selection (p1016 = 2)					20.07.2021 V4.7_13	G115D	

- 3010 -

Fig. 3-67 3010 – Fixed speed setpoints, binary selection (p1016 = 2)

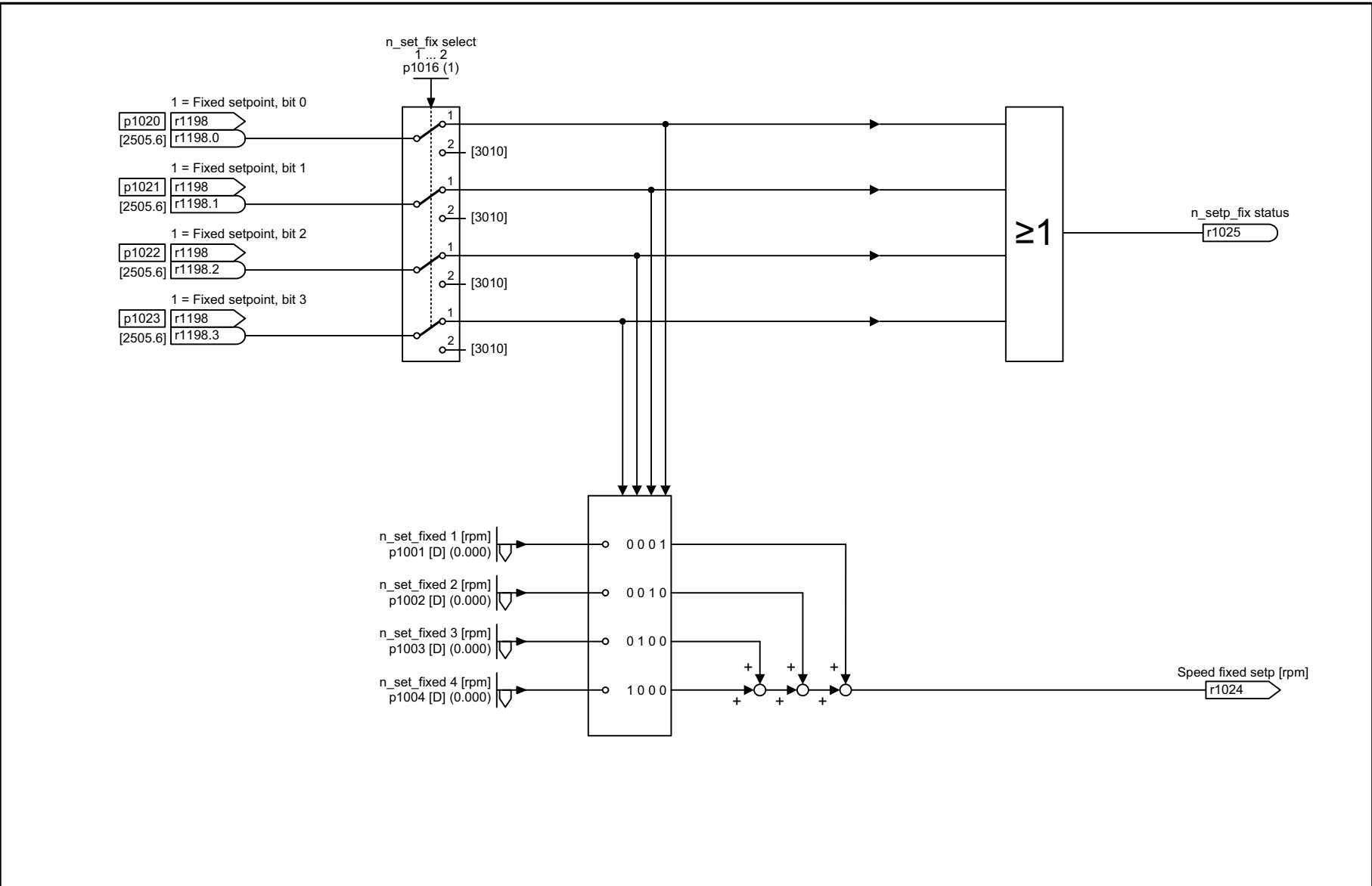

1	2	3	4	5	6	7	8
Setpoint channel					fp_3011_97_51.vsd	Function diagram	
Fixed speed setpoints, direct selection (p1016 = 1)					20.07.2021 V4.7_13	G115D	
							- 3011 -

Fig. 3-68 3011 – Fixed speed setpoints, direct selection (p1016 = 1)

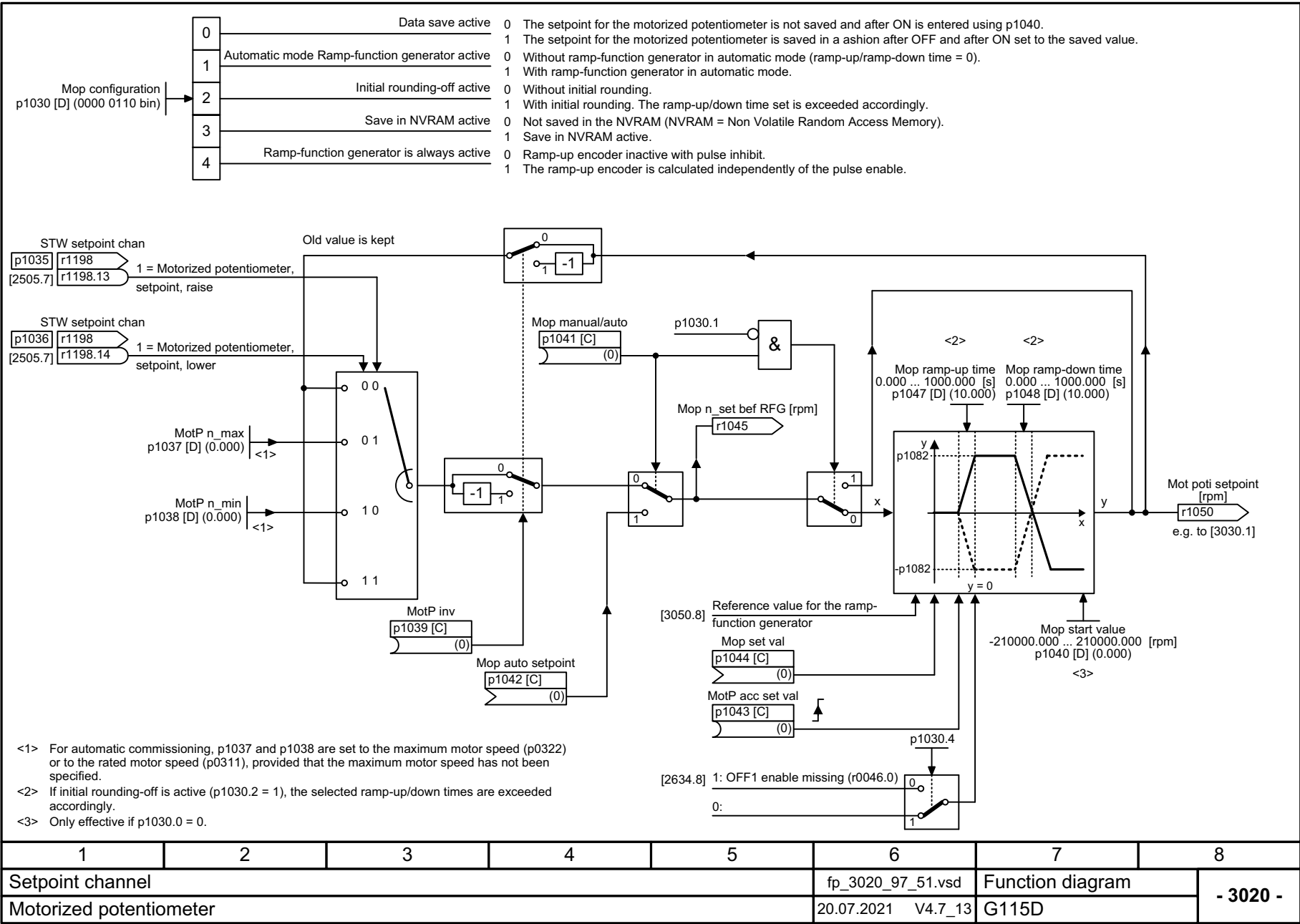

1	2	3	4	5	6	7	8
Setpoint channel					fp_3020_97_51.vsd	Function diagram	
Motorized potentiometer					20.07.2021 V4.7_13	G115D	
- 3020 -							

Fig. 3-69 3020 – Motorized potentiometer

Fig. 3-70 3030 – Main/supplementary setpoint, setpoint scaling, jogging

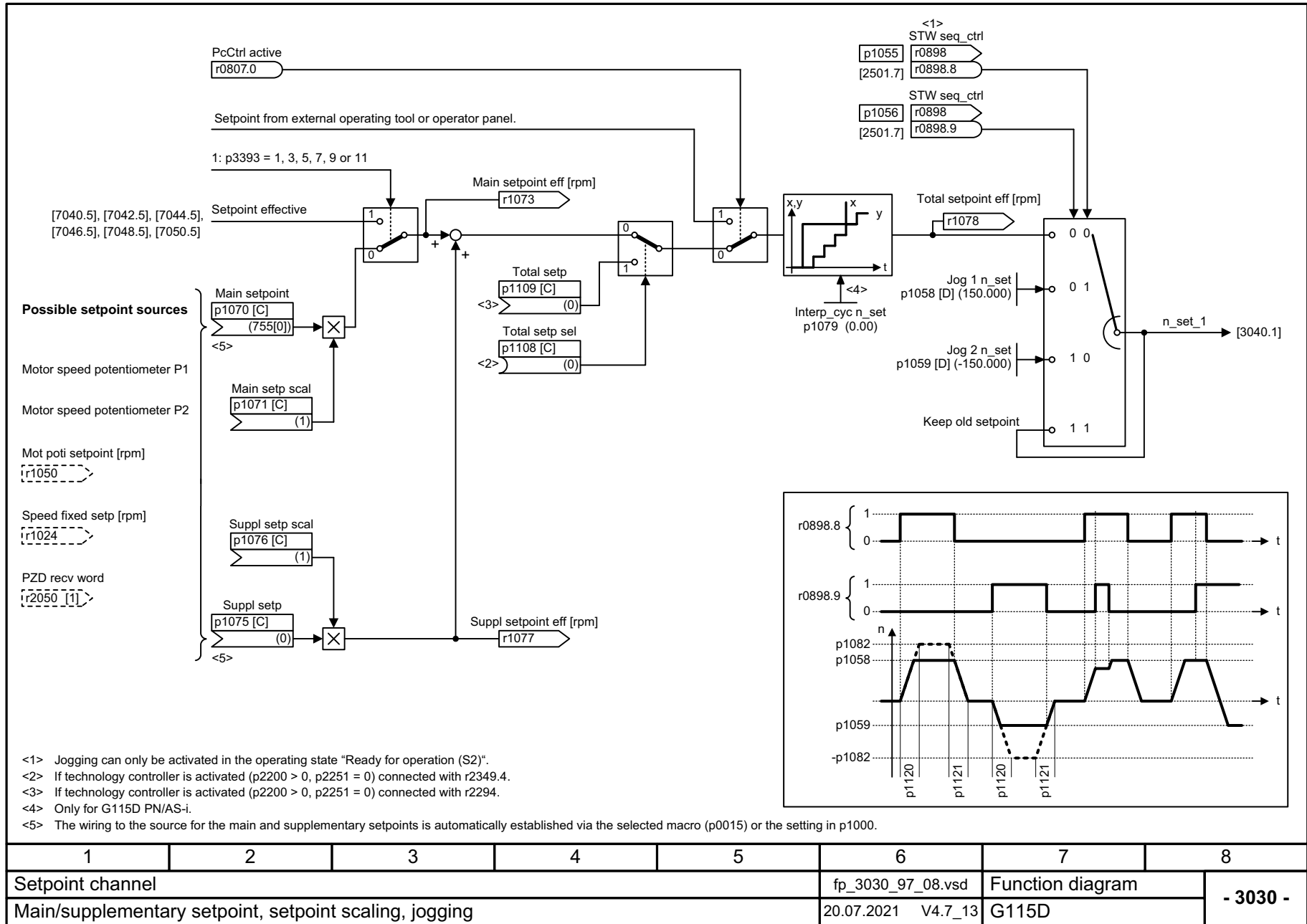

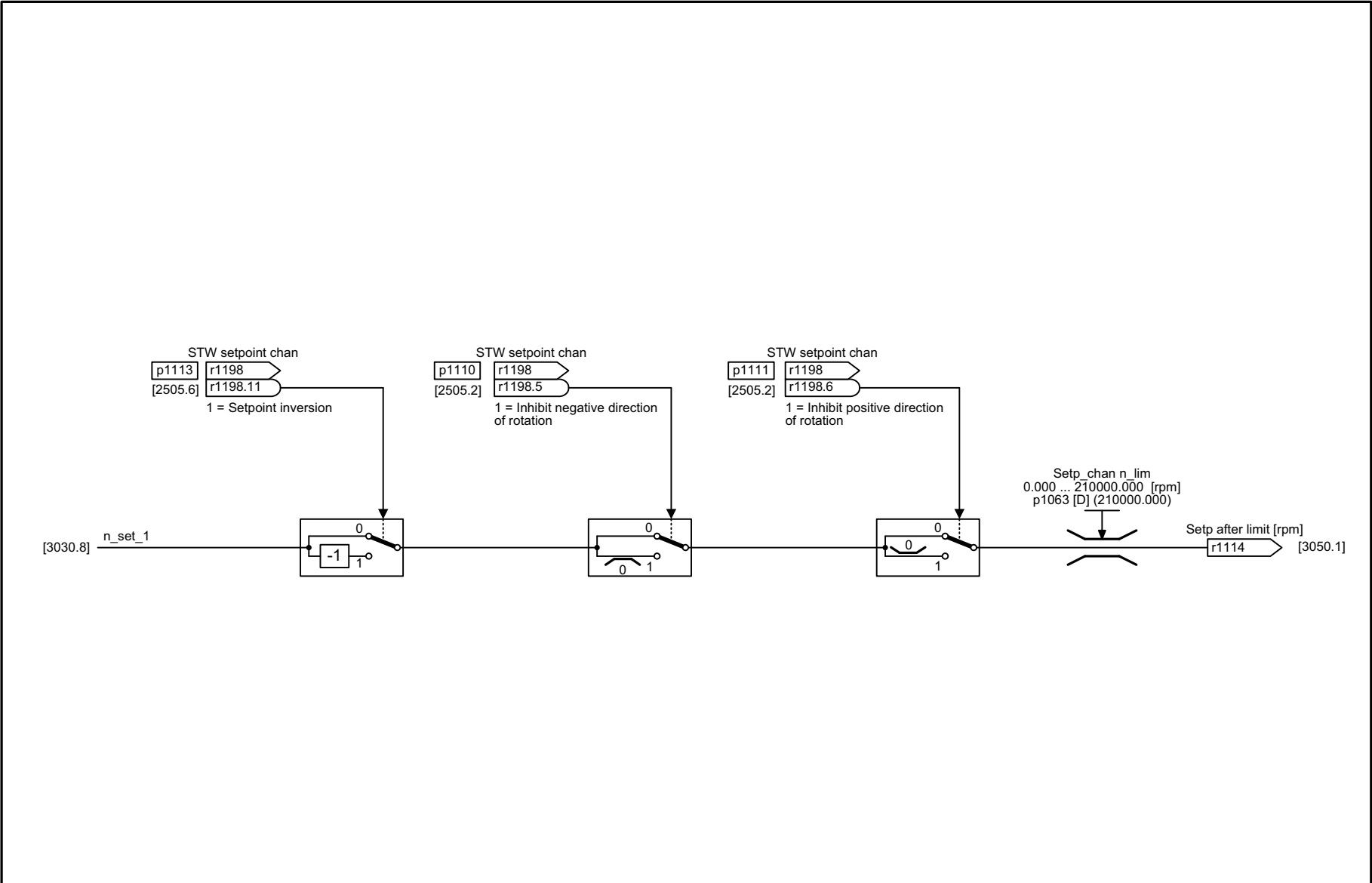
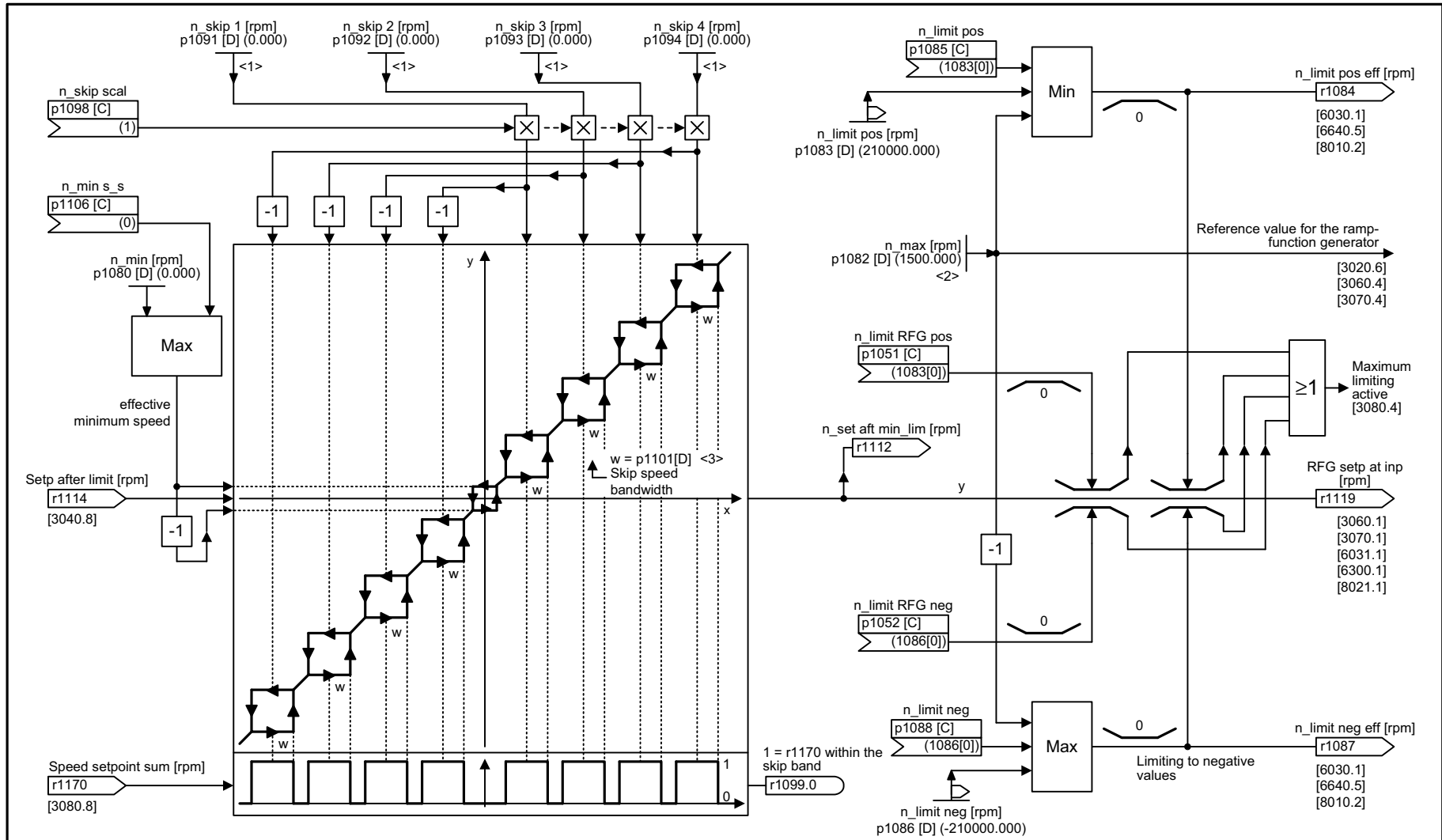

Fig. 3-71 3040 – Direction limitation and direction reversal

1	2	3	4	5	6	7	8
Setpoint channel					fp_3040_97_53.vsd	Function diagram	
Direction limitation and direction reversal					20.07.2021 V4.7_13	G115D	

Fig. 3-72 3050 – Skip frequency bands and speed limitations



- <1> A skip speed of "0" deactivates the skip band.
- <2> Value of p1082 is limited to maximum motor speed (p0322).
- <3> If the drive is not stopped via the input setpoint, but via controlled intervention, the lower hysteresis branch is relevant after a subsequent run-up.

1	2	3	4	5	6	7	8
Setpoint channel					fp_3050_97_51.vsd	Function diagram	
Skip frequency bands and speed limitations					20.07.2021 V4.7_13	G115D	
							- 3050 -

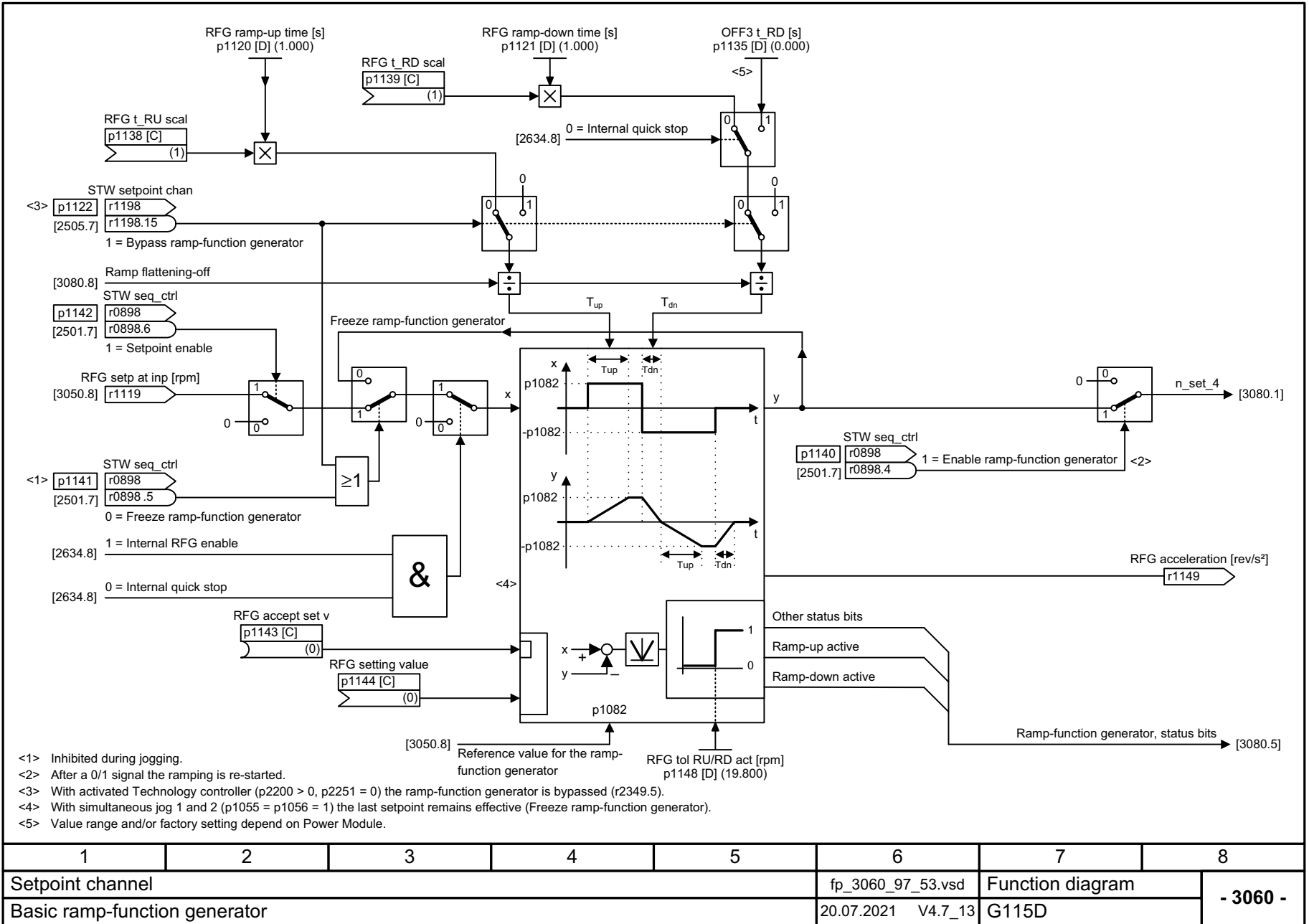
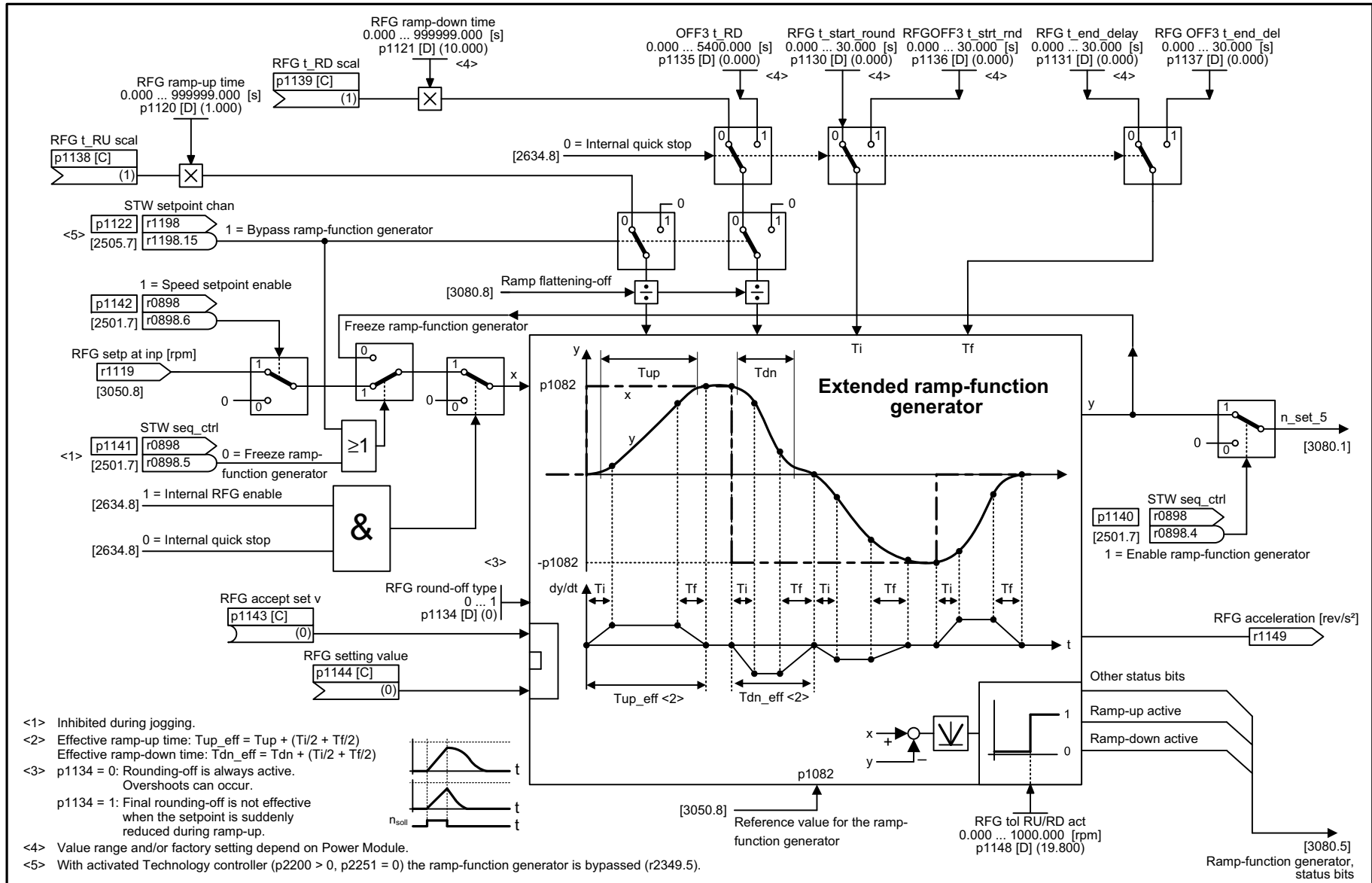

Fig. 3-73 3060 – Basic ramp-function generator

Fig. 3-74 3070 – Extended ramp-function generator



1	2	3	4	5	6	7	8
Setpoint channel					fp_3070_97_51.vsd	Function diagram	
Extended ramp-function generator					20.07.2021 V4.7_13	G115D	
							- 3070 -

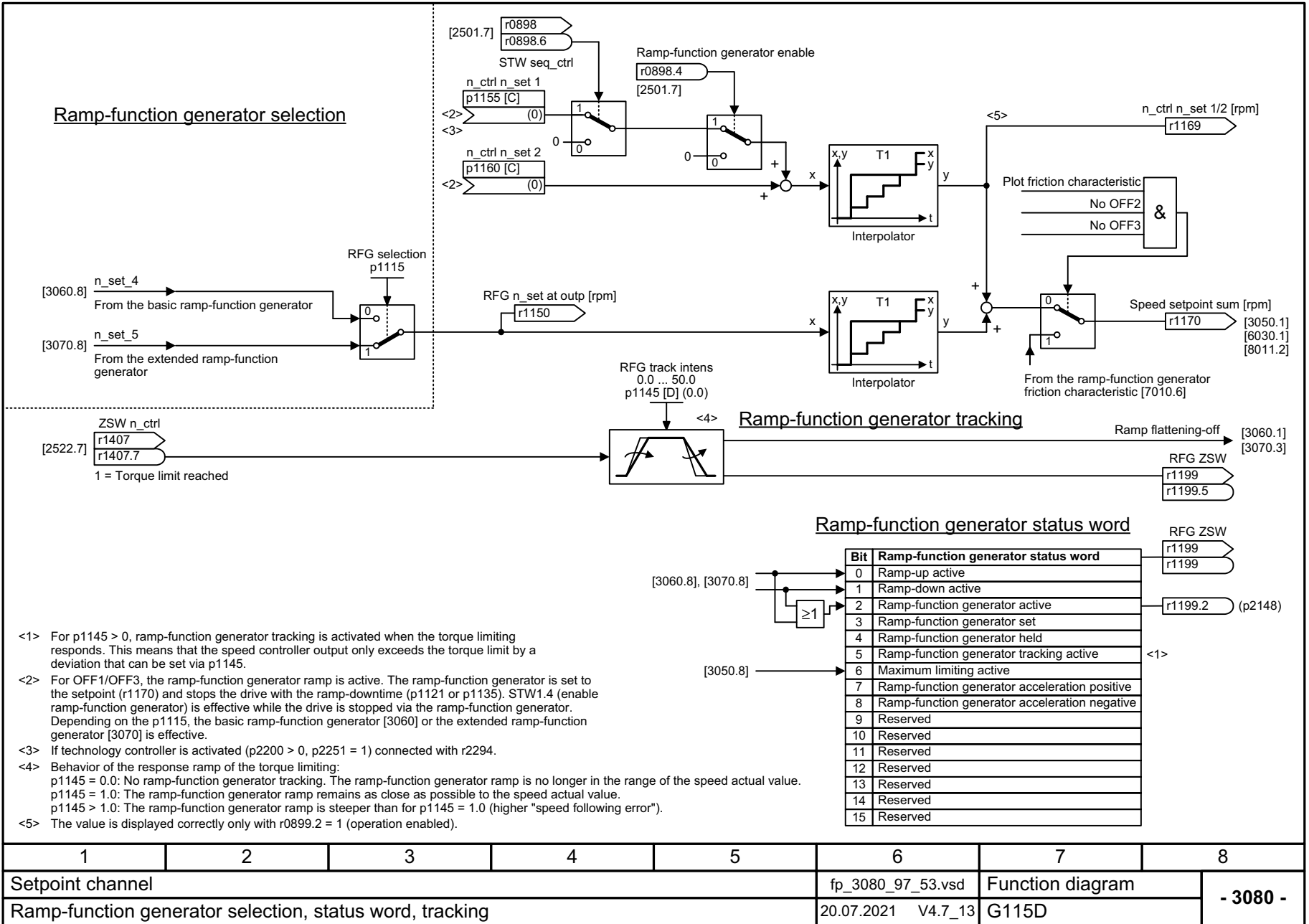

Fig. 3-75 3080 – Ramp-function generator selection, status word, tracking

1	2	3	4	5	6	7	8
Setpoint channel					fp_3080_97_53.vsd	Function diagram	
Ramp-function generator selection, status word, tracking					20.07.2021 V4.7_13	G115D	
- 3080 -							

3.12 Encoder evaluation

Function diagrams

4704 – Position sensing encoder 1

584

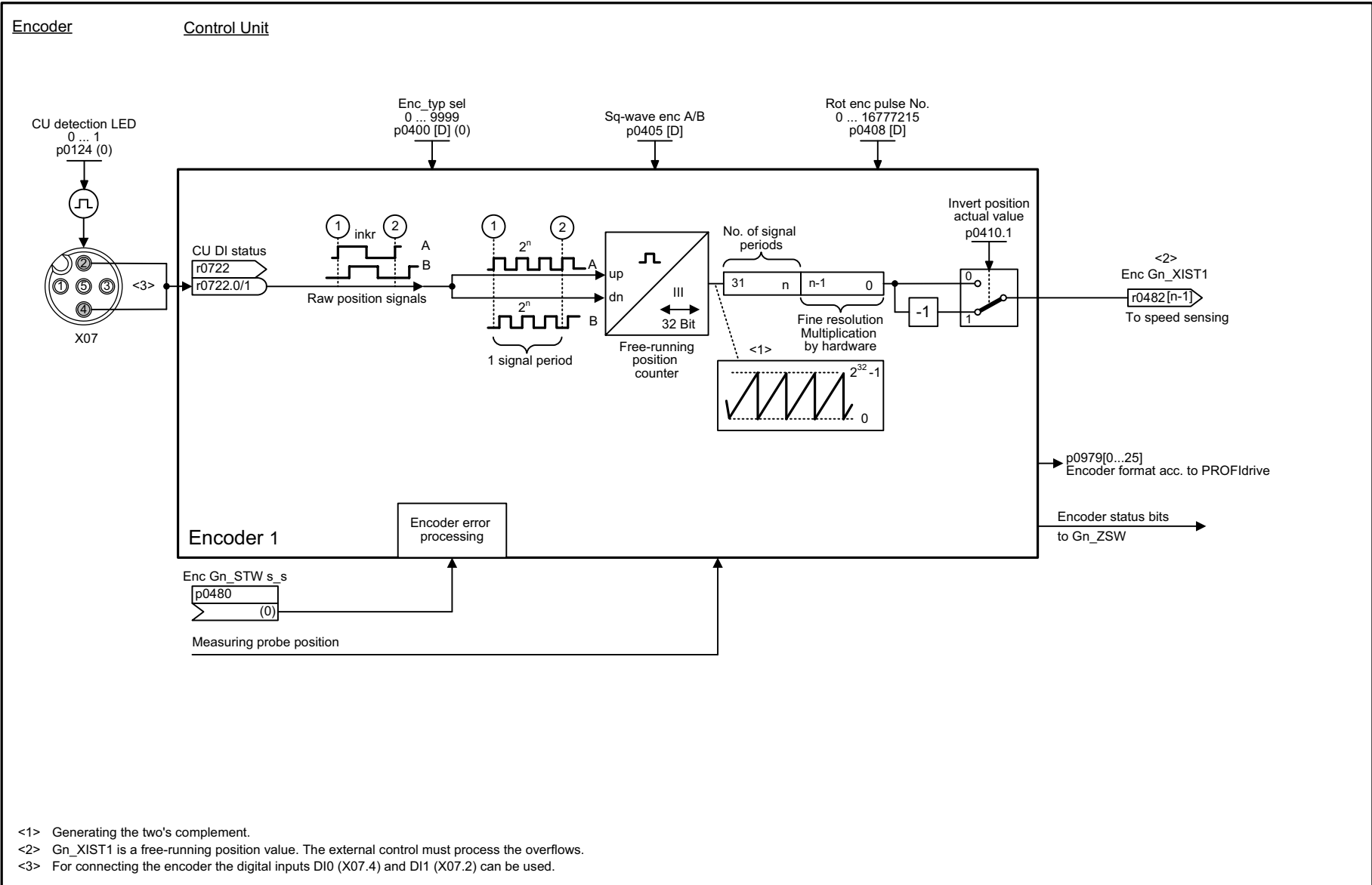

<1> Generating the two's complement.
 <2> Gn_XIST1 is a free-running position value. The external control must process the overflows.
 <3> For connecting the encoder the digital inputs DI0 (X07.4) and DI1 (X07.2) can be used.

1	2	3	4	5	6	7	8
Encoder evaluation					fp_4704_97_08.vsd	Function diagram	
Position sensing, encoder 1					20.07.2021 V4.7_13	G115D	
- 4704 -							

Fig. 3-76 4704 – Position sensing encoder 1

3.13 Vector control / U/f control

Function diagrams

6020 – Speed control and generation of the torque limits, overview	587
6030 – Speed setpoint, droop	588
6031 – Precontrol symmetrization, acceleration model	589
6035 – Moment of inertia estimator	590
6040 – Speed controller	591
6050 – K_p_n -/ T_n_n adaptation	592
6060 – Torque setpoint	593
6220 – V_{dc_max} controller and V_{dc_min} controller	594
6300 – U/f control, overview	595
6301 – U/f control, characteristic and voltage boost	596
6310 – U/f control, resonance damping and slip compensation	597
6320 – U/f control, V_{dc_max} controller	598
6490 – Speed control configuration	599
6491 – Flux control configuration	600
6630 – Upper/lower torque limit	601
6640 – Current/power/torque limits	602
6700 – Current control, overview	603
6710 – Current setpoint filter	604
6714 – I_q and I_d controllers	605
6721 – I_d setpoint (PMSM, p0300 = 2xx)	606
6722 – Field weakening characteristic, flux setpoint (ASM, p0300 = 1)	607
6723 – Field weakening controller, flux controller, I_d setpoint (ASM, p0300 = 1)	608
6724 – Field weakening controller (PMSM, p0300 = 2xx)	609
6730 – Interface to the Power Module (ASM, p0300 = 1xx)	610
6731 – Interface to the Power Module (PMSM, p0300 = 2xx)	611
6790 – Flux setpoint (RESM, p0300 = 6xx)	612
6791 – I_d setpoint (RESM, p0300 = 6xx)	613

3 Function diagrams

3.13 Vector control / U/f control

6792 – Interface to the Power Module (RESM, p0300 = 6xx)	614
6799 – Display signals	615

Fig. 3-77 6020 – Speed control and generation of the torque limits, overview

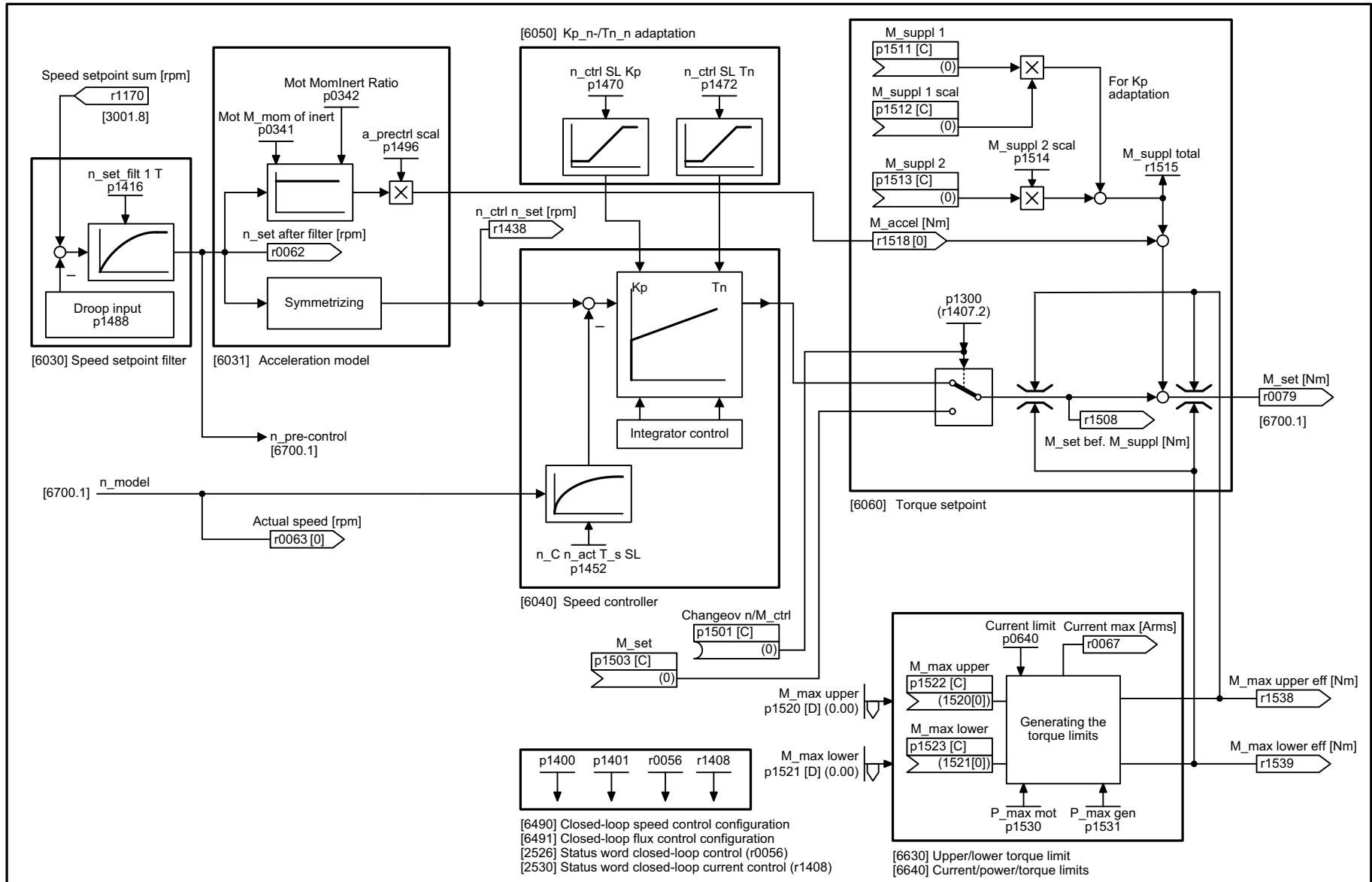

1	2	3	4	5	6	7	8
Vector control / U/f control					fp_6020_97_70.vsd	Function diagram	
Speed control and generation of the torque limits, overview					20.07.2021 V4.7_13	G115D	
							- 6020 -

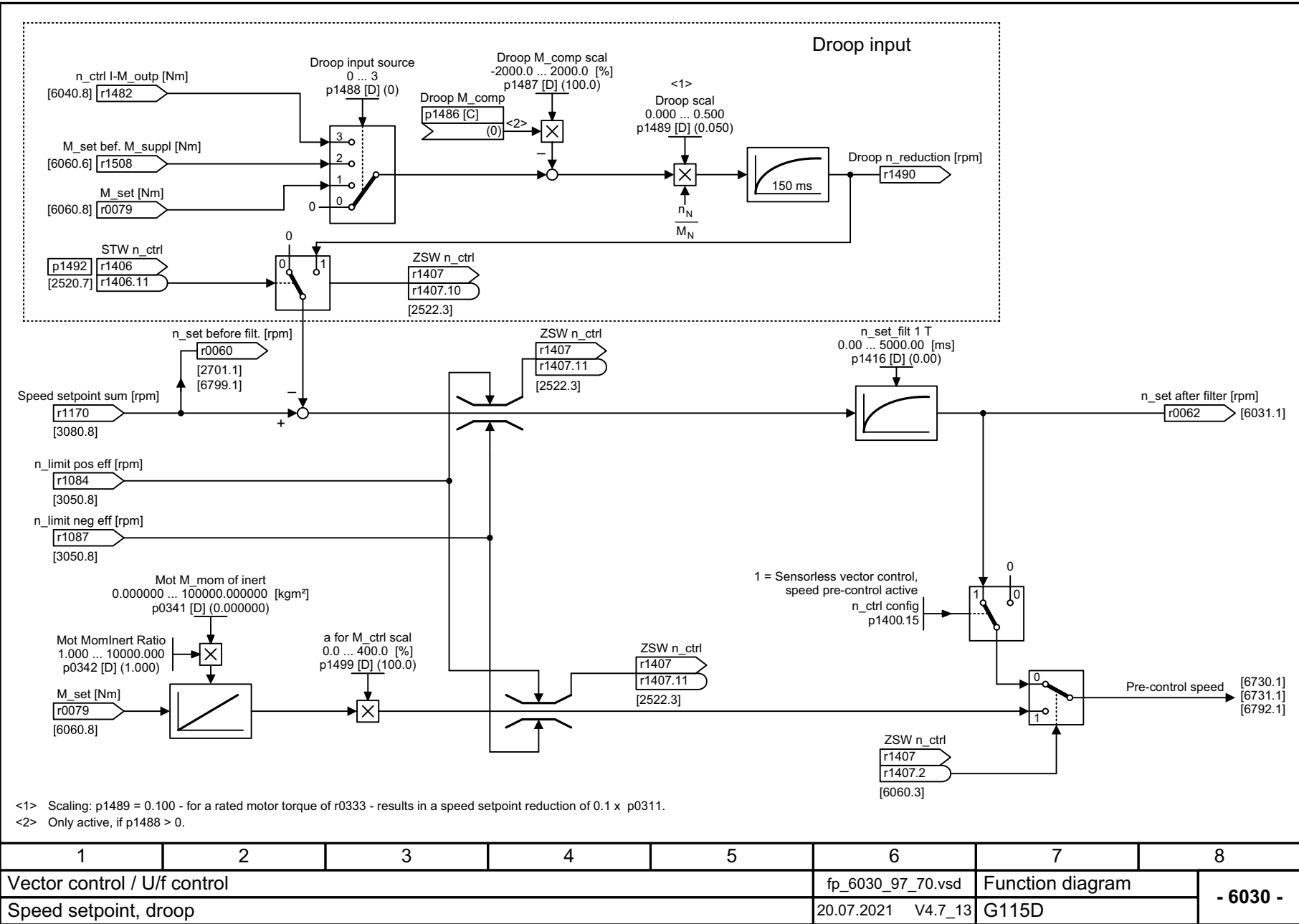
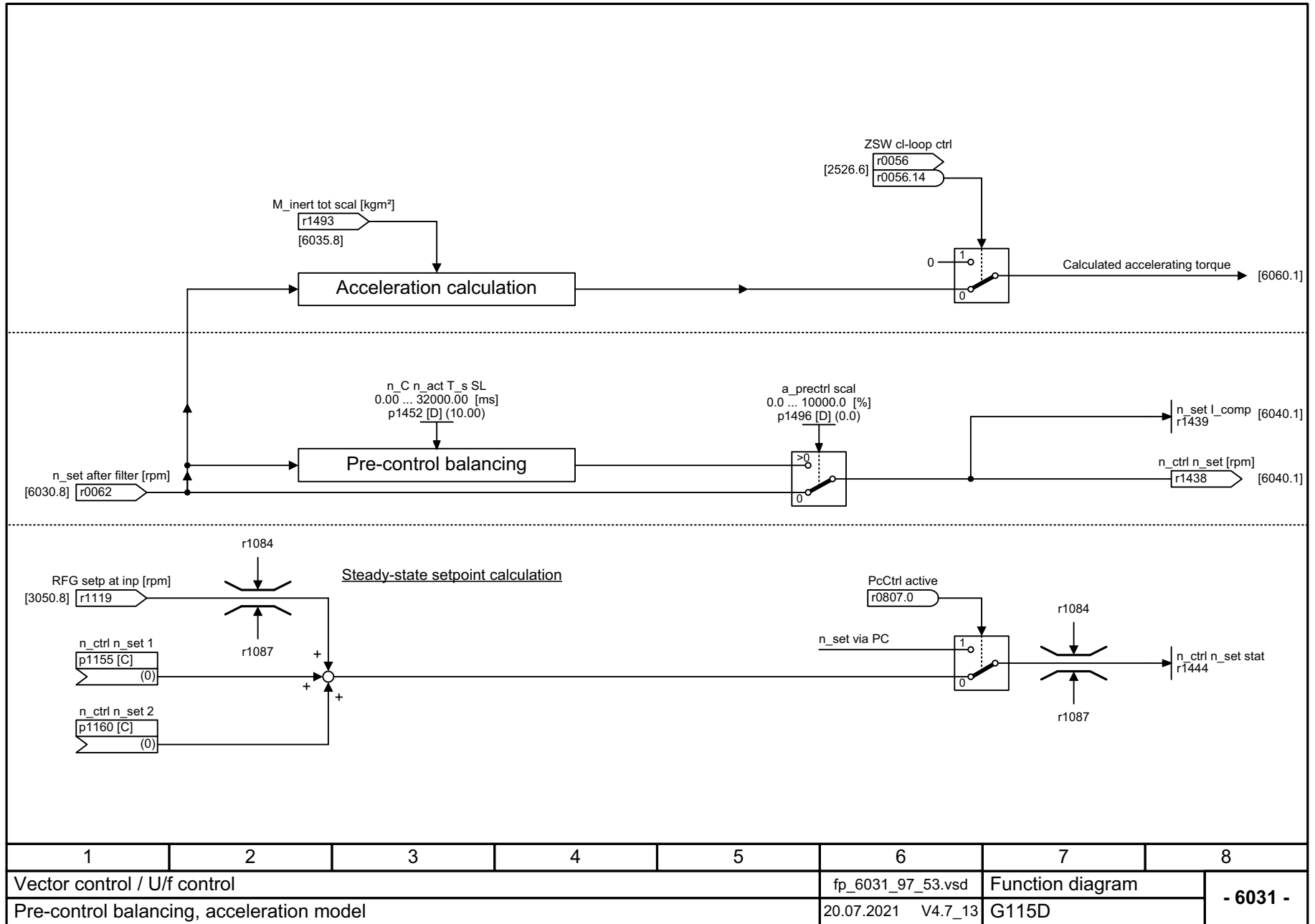

Fig. 3-78 6030 – Speed setpoint, droop

Fig. 3-79 6031 – Precontrol symmetrization, acceleration model



1	2	3	4	5	6	7	8
Vector control / U/f control					fp_6031_97_53.vsd	Function diagram	
Pre-control balancing, acceleration model					20.07.2021 V4.7_13	G115D	
							- 6031 -

Fig. 3-81 6040 – Speed controller

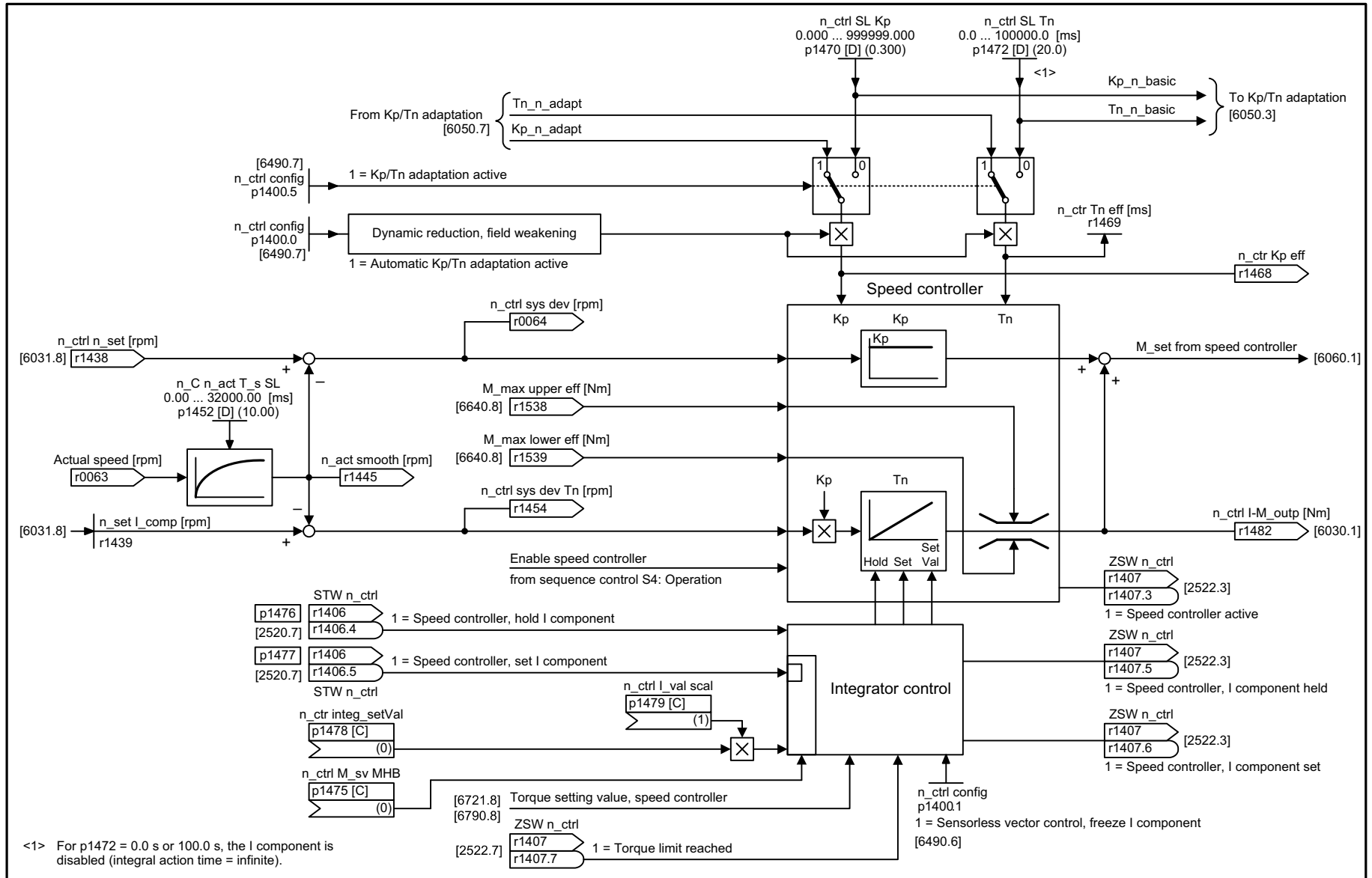

1	2	3	4	5	6	7	8
Vector control / U/f control					fp_6040_97_70.vsd	Function diagram	
Speed controller					20.07.2021 V4.7_13	G115D	
- 6040 -							

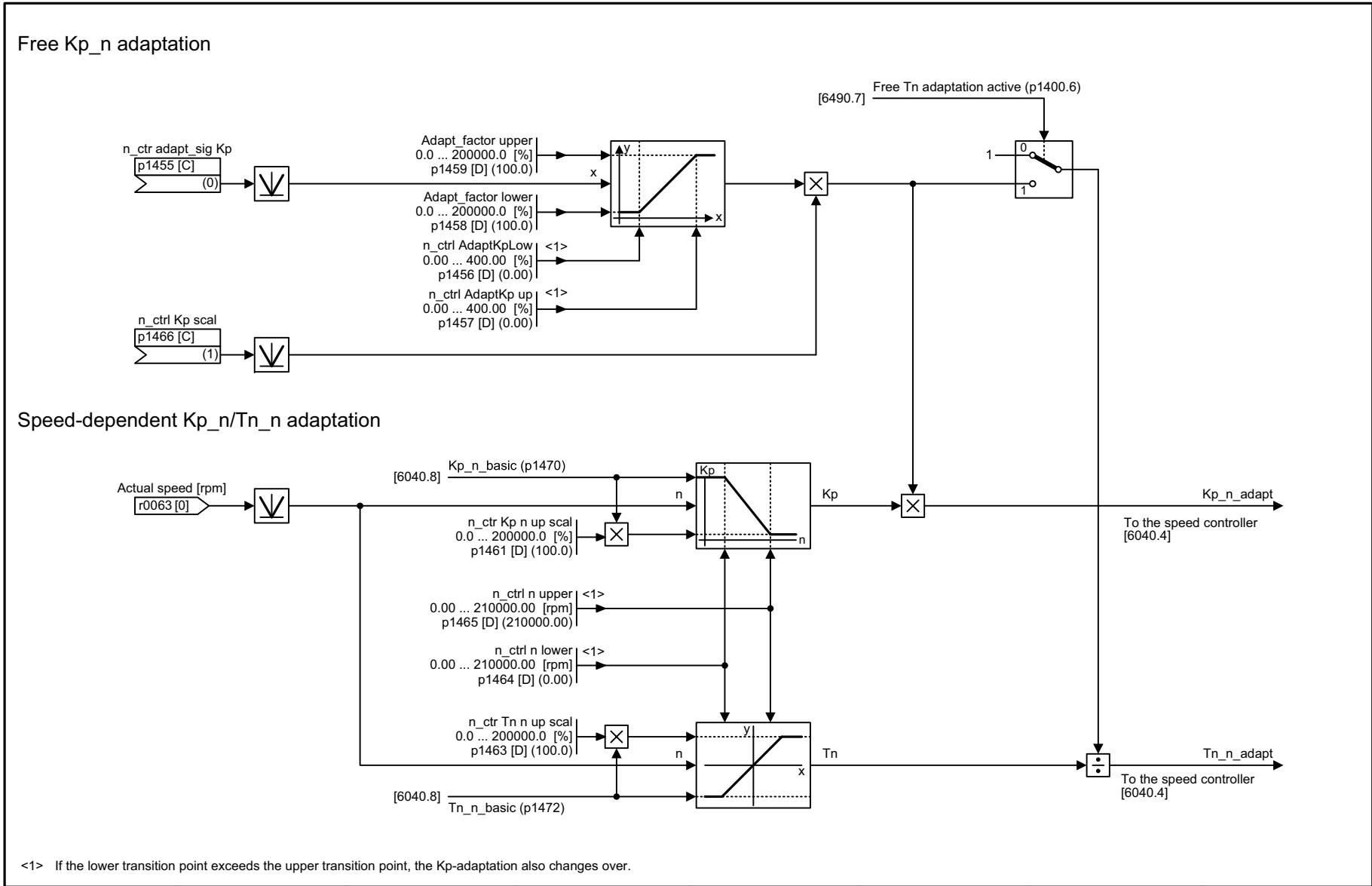

1	2	3	4	5	6	7	8
Vector control / U/f control					fp_6050_97_70.vsd	Function diagram	
Kp_n/Tn_n adaptation					20.07.2021 V4.7_13	G115D	

Fig. 3-82 6050 – Kp_n/Tn_n adaptation

Fig. 3-83 6060 – Torque setpoint

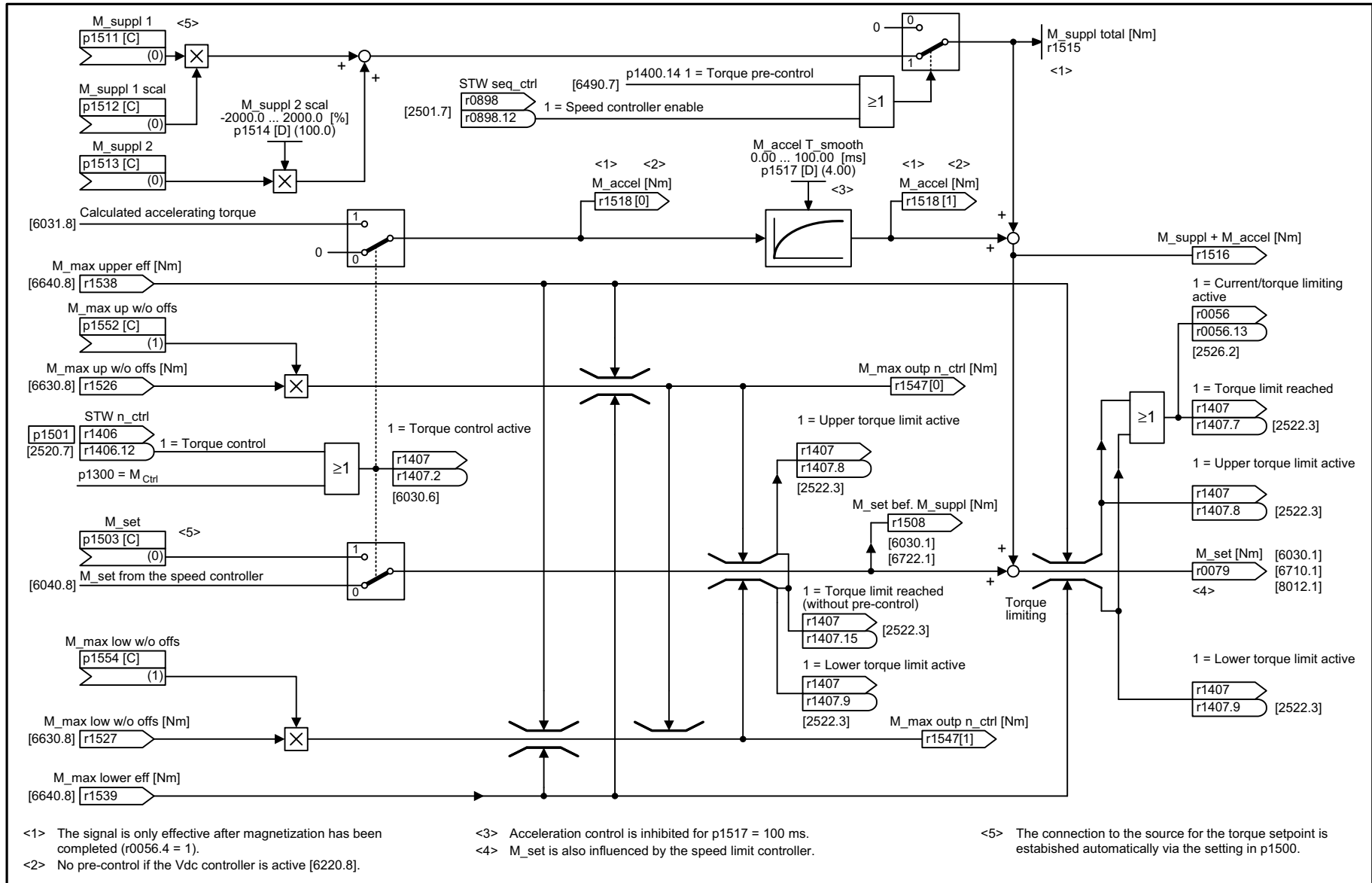

<1> The signal is only effective after magnetization has been completed (r0056.4 = 1).
<2> No pre-control if the Vdc controller is active [6220.8].

<3> Acceleration control is inhibited for p1517 = 100 ms.
<4> M_set is also influenced by the speed limit controller.

<5> The connection to the source for the torque setpoint is established automatically via the setting in p1500.

1	2	3	4	5	6	7	8
Vector control / U/f control					fp_6060_97_53.vsd	Function diagram	
Torque setpoint					20.07.2021 V4.7_13	G115D	
							- 6060 -

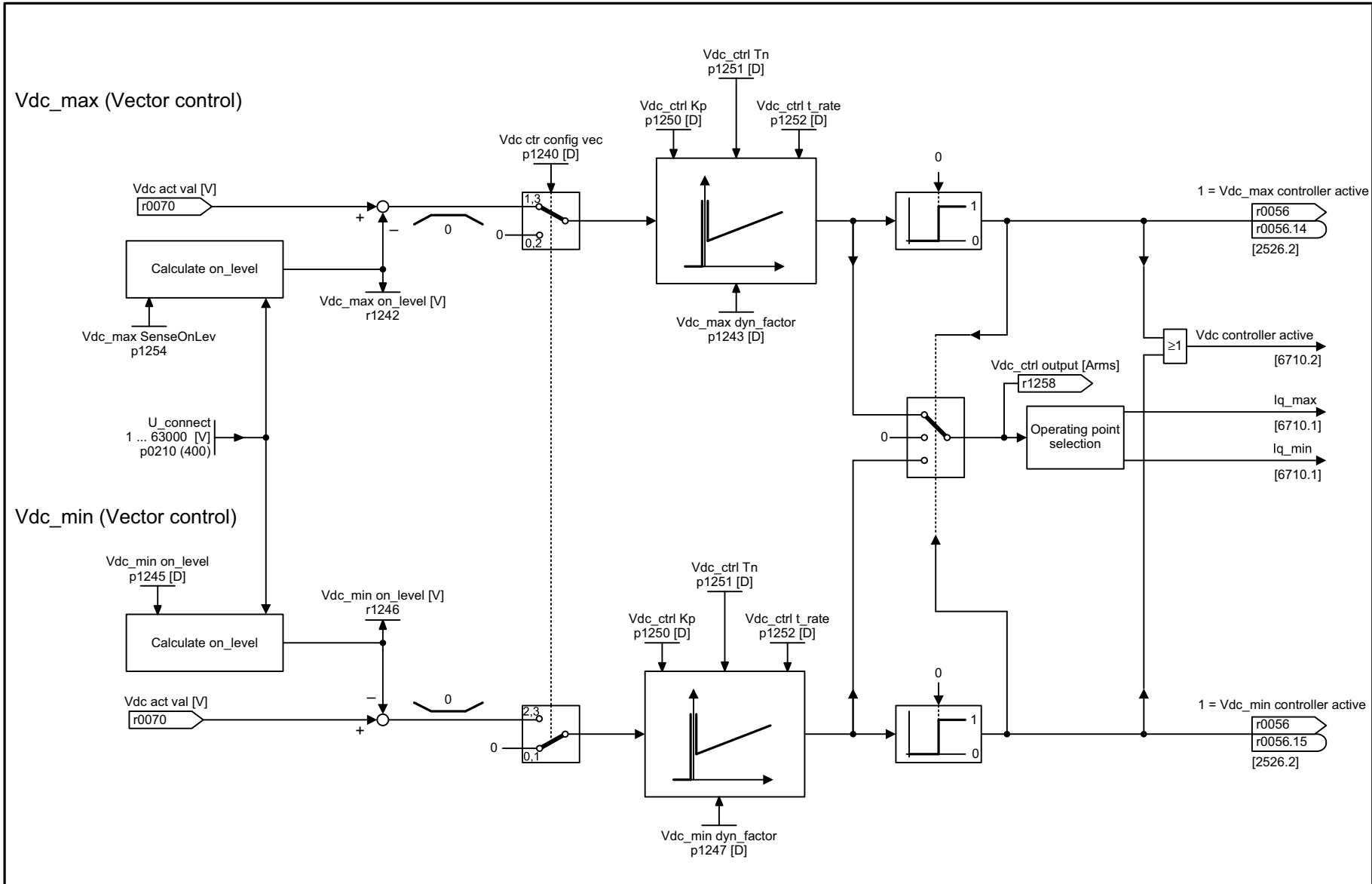

1	2	3	4	5	6	7	8
Vector control / U/f control					fp_6220_97_08.vsd	Function diagram	
Vdc_max controller and Vdc_min controller					20.07.2021 V4.7_13	G115D	

- 6220 -

Fig. 3-84 6220 – Vdc_max controller and Vdc_min controller

Fig. 3-85 6300 – U/f control, overview

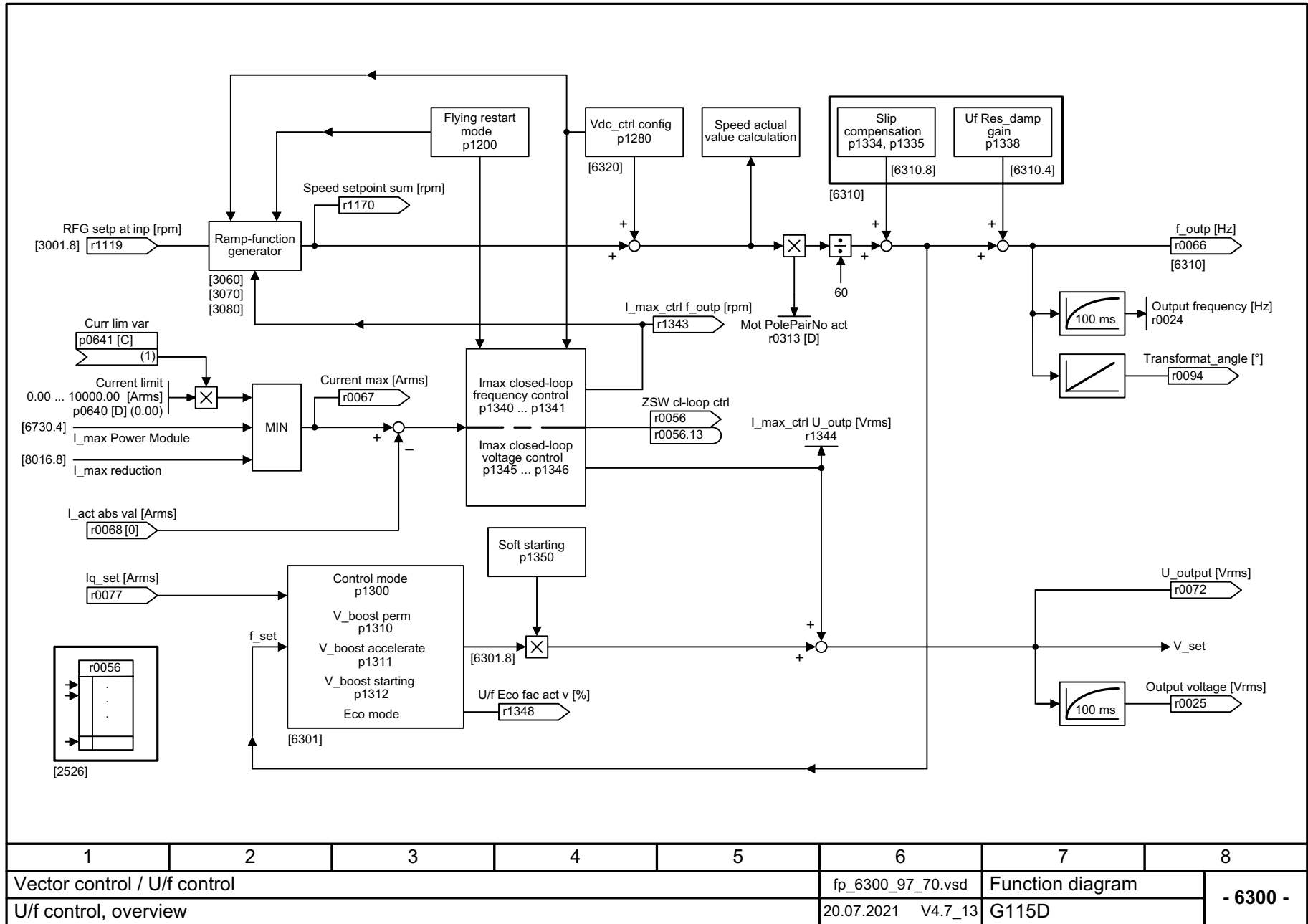

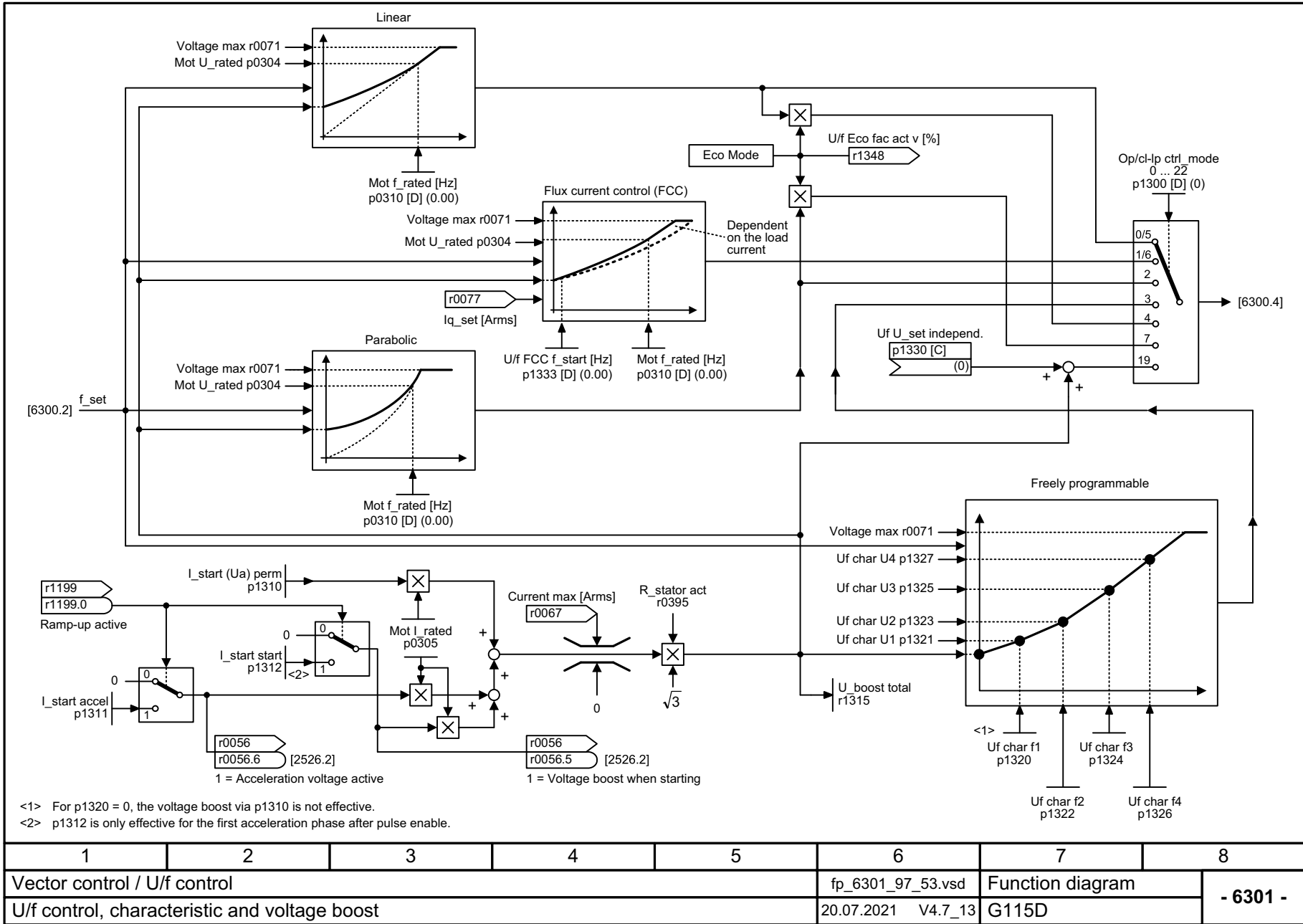

1	2	3	4	5	6	7	8
Vector control / U/f control					fp_6301_97_53.vsd	Function diagram	
U/f control, characteristic and voltage boost					20.07.2021 V4.7_13	G115D	
- 6301 -							

Fig. 3-86 6301 – U/f control, characteristic and voltage boost

Fig. 3-87 6310 – U/f control, resonance damping and slip compensation

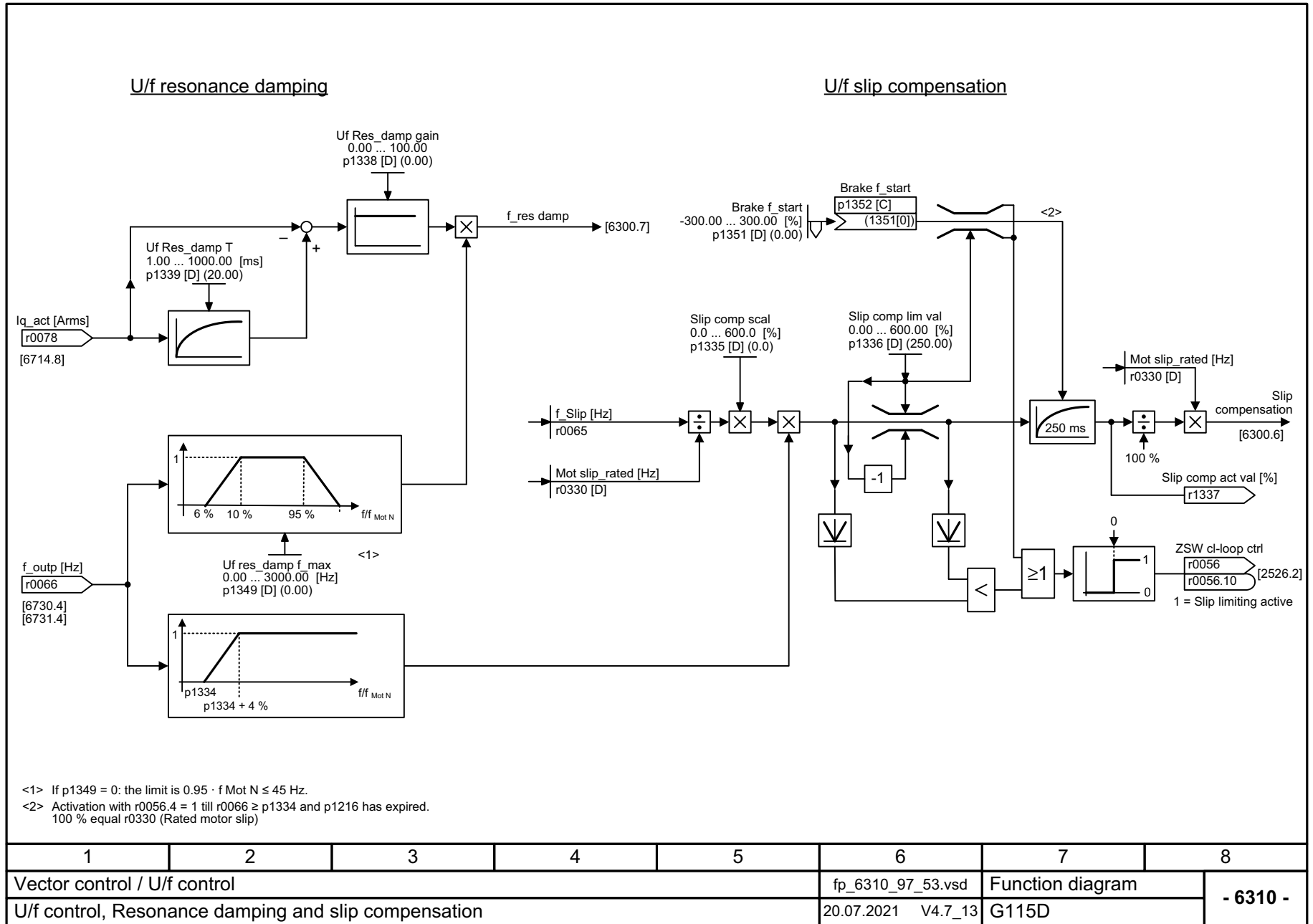

1	2	3	4	5	6	7	8
Vector control / U/f control					fp_6310_97_53.vsd	Function diagram	
U/f control, Resonance damping and slip compensation					20.07.2021 V4.7_13	G115D	
							- 6310 -

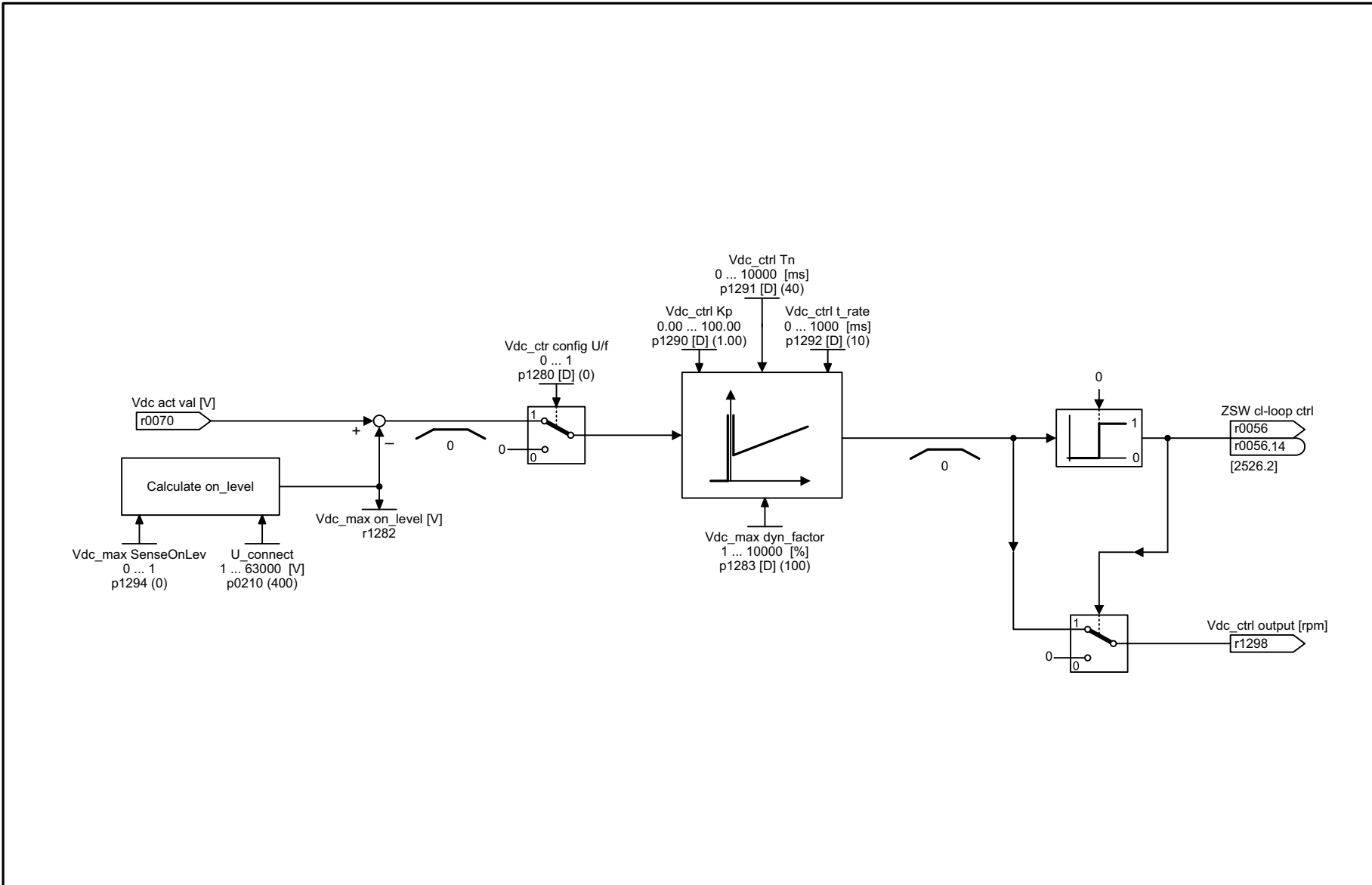

Fig. 3-88 6320 – U/f control, Vdc_max controller

1	2	3	4	5	6	7	8
Vector control / U/f control					fp_6320_97_70.vsd	Function diagram	
U/f control, Vdc_max controller					20.07.2021 V4.7_13	G115D	

Speed control configuration		Factory setting	
Bit No.	Meaning		
00	1 = Automatic Kp/Tn adaptation active	1	[6040.2]
01	1 = Sensorless vector control, freeze I component	0	[6040.6]
...	Reserved		
05	1 = Kp/Tn adaptation active	1	[6040.2]
06	1 = Free Tn adaptation active	0	[6050.6]
...	Reserved		
14	1 = Torque pre-control always active 0 = Torque pre-control for n_ctrl enabled	0	[6060.4]
15	1 = Sensorless vector control, speed pre-control active	1	[6030.6]
16	1 = I component for limiting enabled	0	
...	Reserved		
18	1 = Moment of inertia estimator active	0	
19	Reserved		
20	1 = Acceleration model	0	
21	Reserved		
22	1 = Obtain moment of inertia estimator value for pulse inhibit	0	
23	Reserved	0	
24	1 = Moment of inertia estimator fast estimation active	0	
25	1 = Acceleration torque instantaneous in the I/f mode	0	

1	2	3	4	5	6	7	8
Vector control / U/f control					fp_6490_97_63.vsd	Function diagram	
Speed control configuration					20.07.2021 V4.7_13	G115D	

- 6490 -

Fig. 3-89 6490 – Speed control configuration

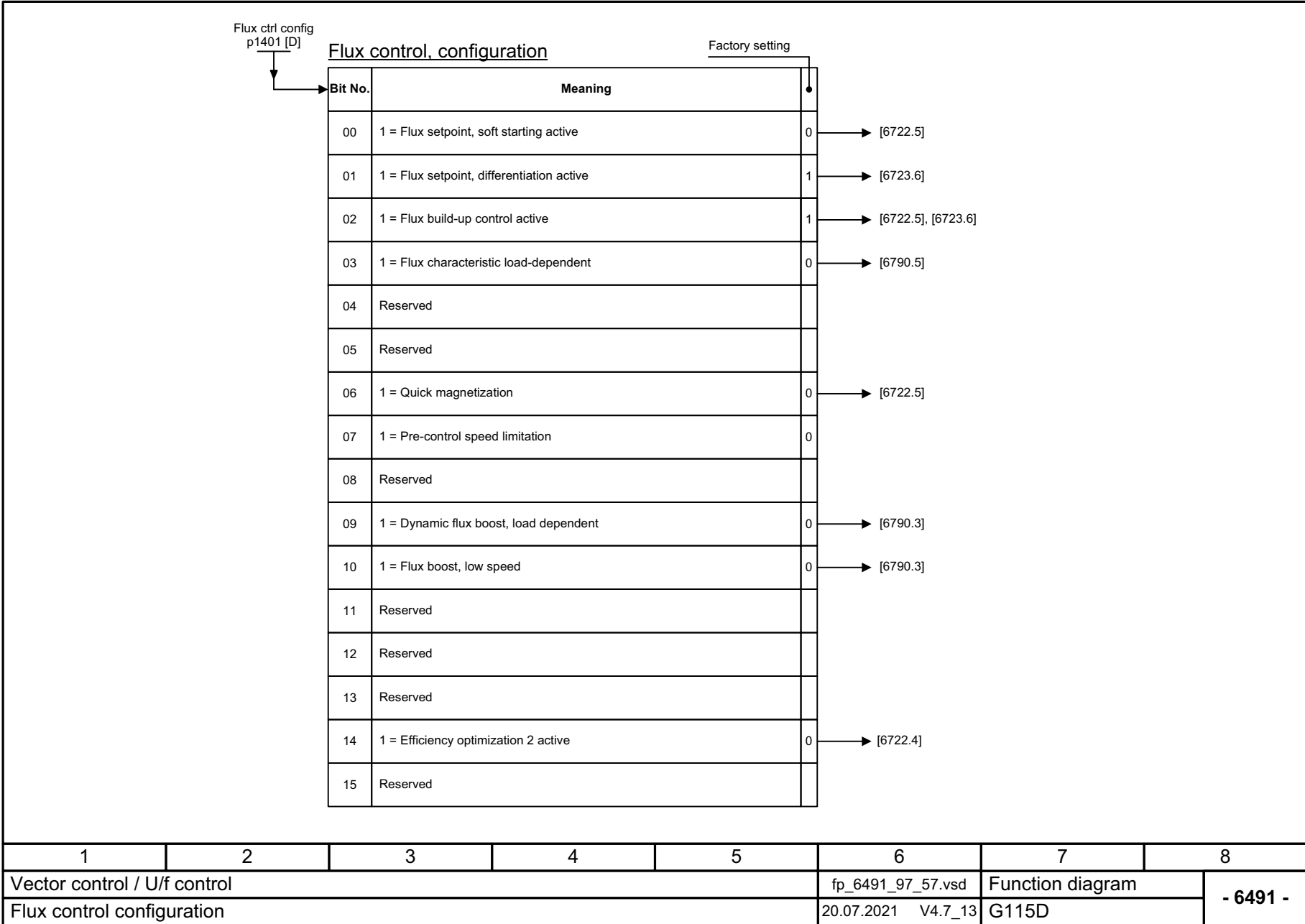
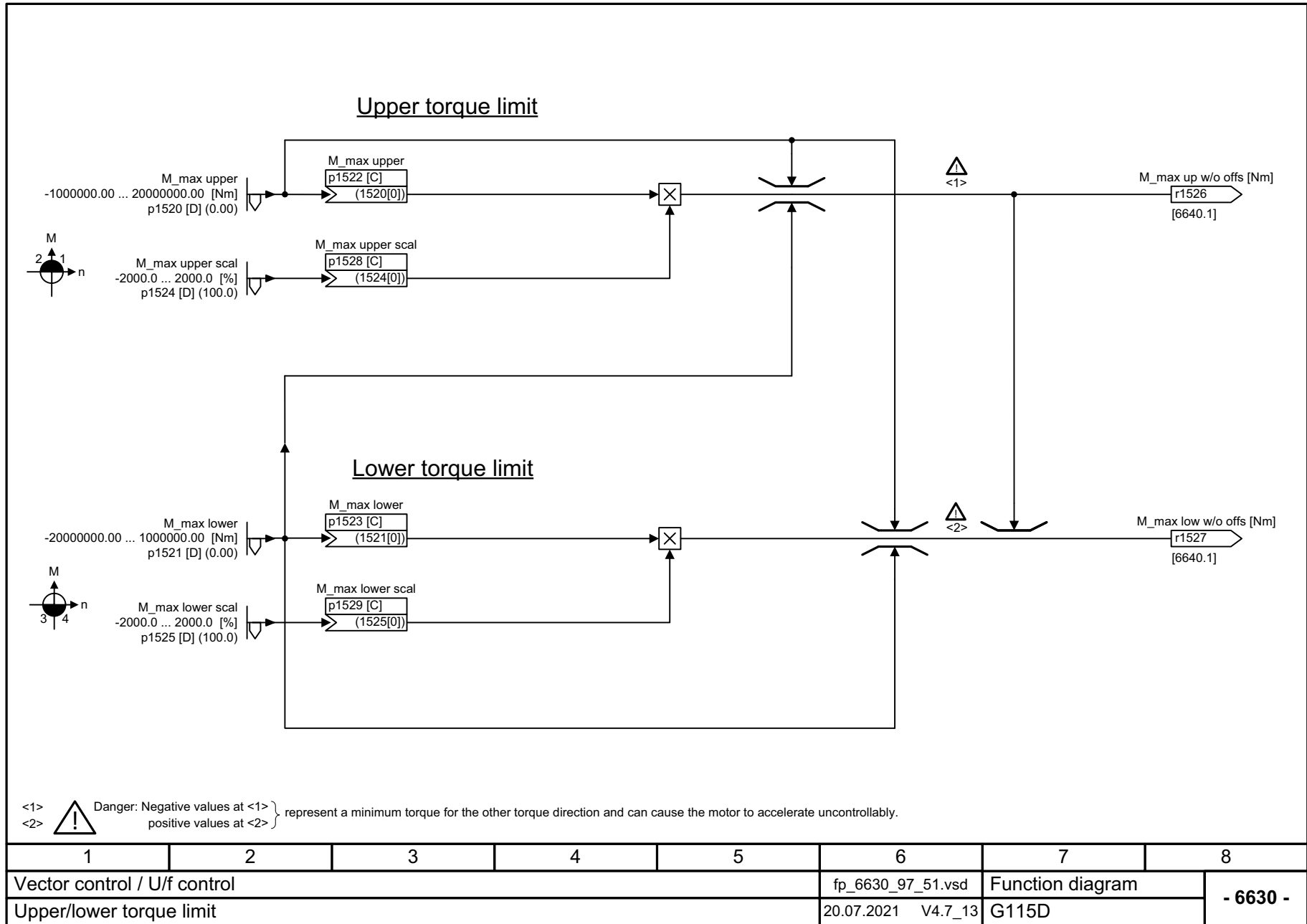
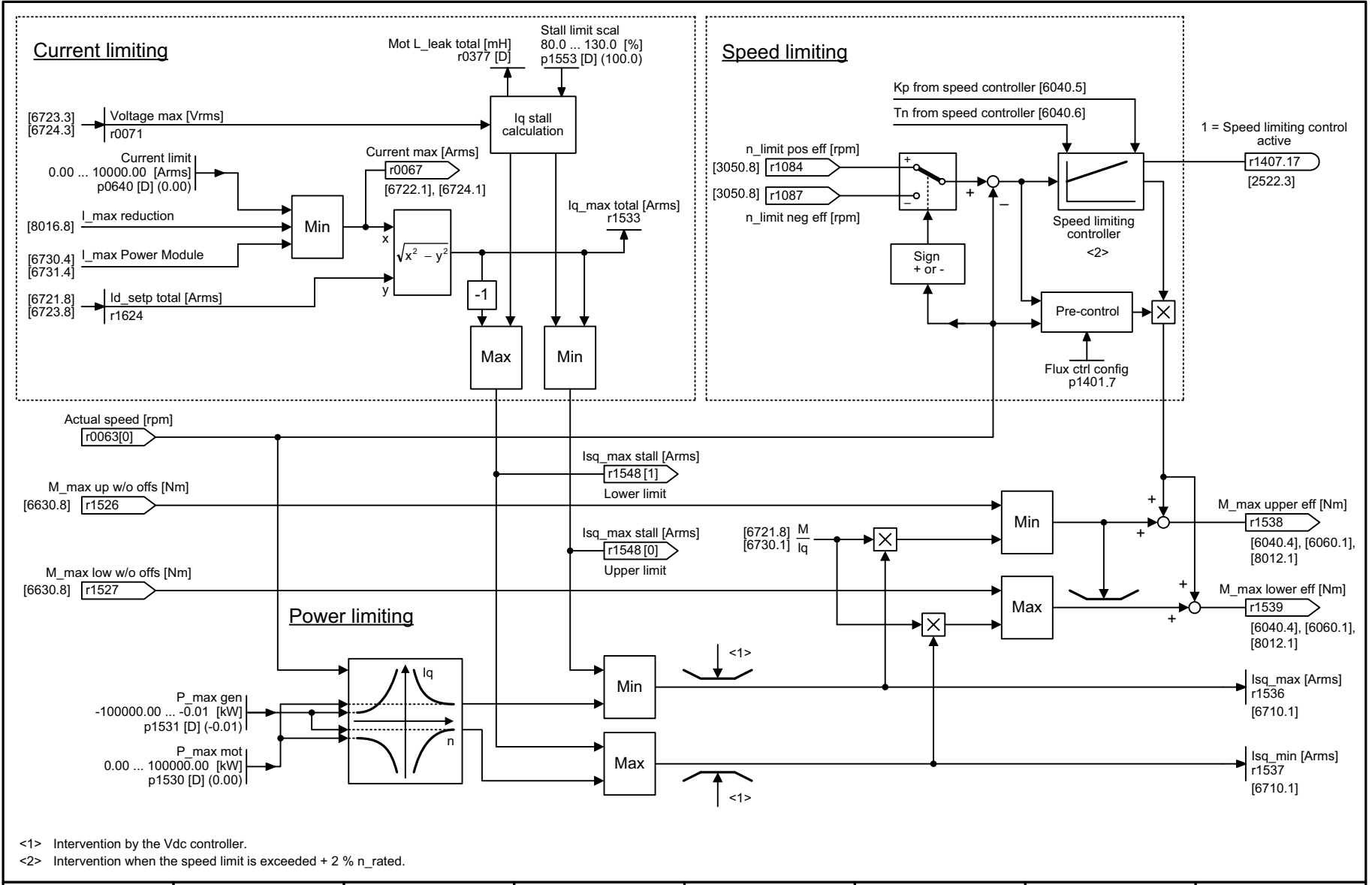

Fig. 3-90 6491 – Flux control configuration

Fig. 3-91 6630 – Upper/lower torque limit





1	2	3	4	5	6	7	8
Vector control / U/f control					fp_6640_97_53.vsd	Function diagram	
Current/power/torque limits					20.07.2021 V4.7_13	G115D	

- 6640 -

Fig. 3-92 6640 – Current/power/torque limits

Fig. 3-93 6700 – Current control, overview

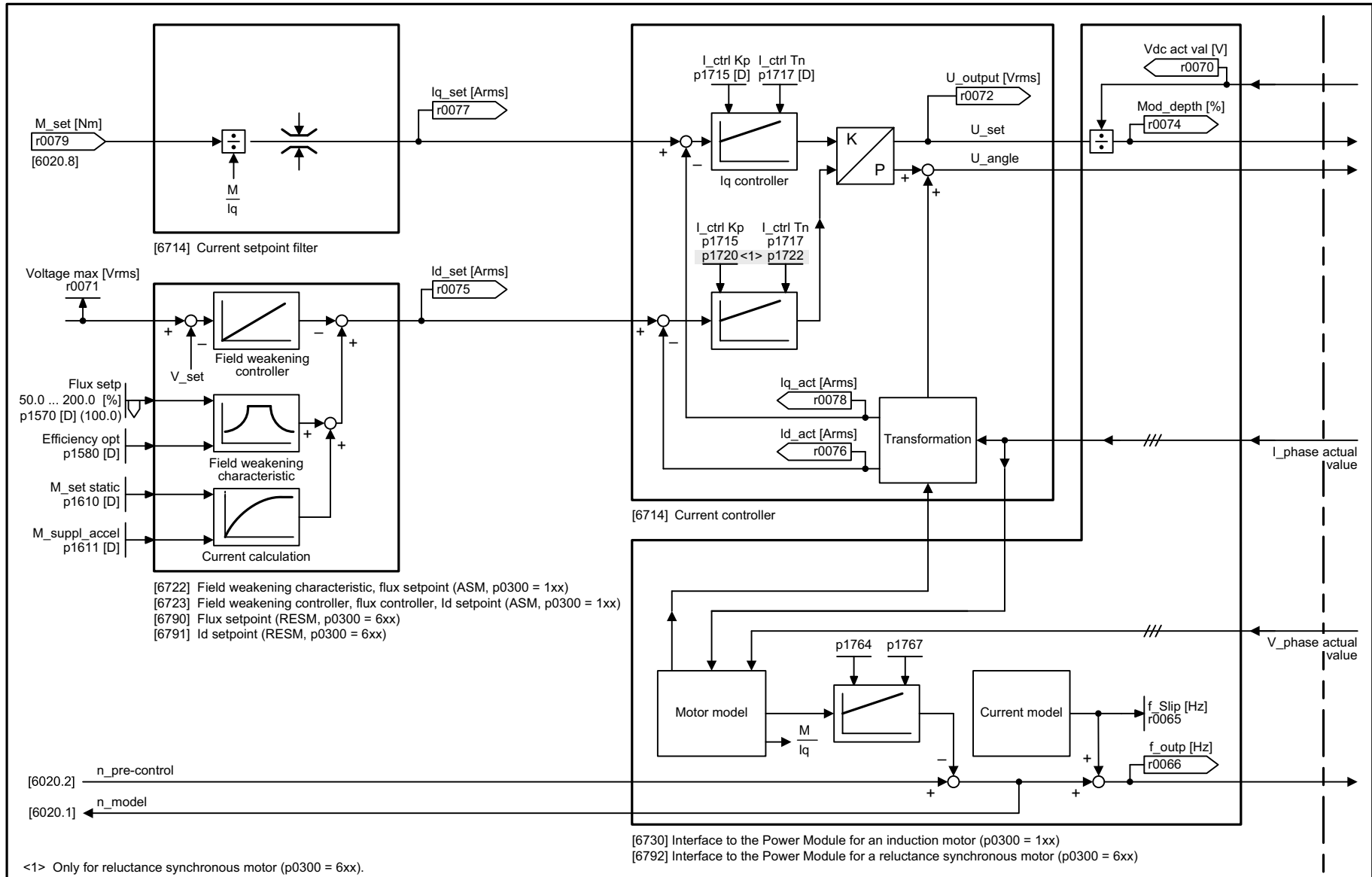

1	2	3	4	5	6	7	8
Vector control / U/f control					fp_6700_97_70.vsd	Function diagram	
Current control, overview					20.07.2021 V4.7_13	G115D	
							- 6700 -

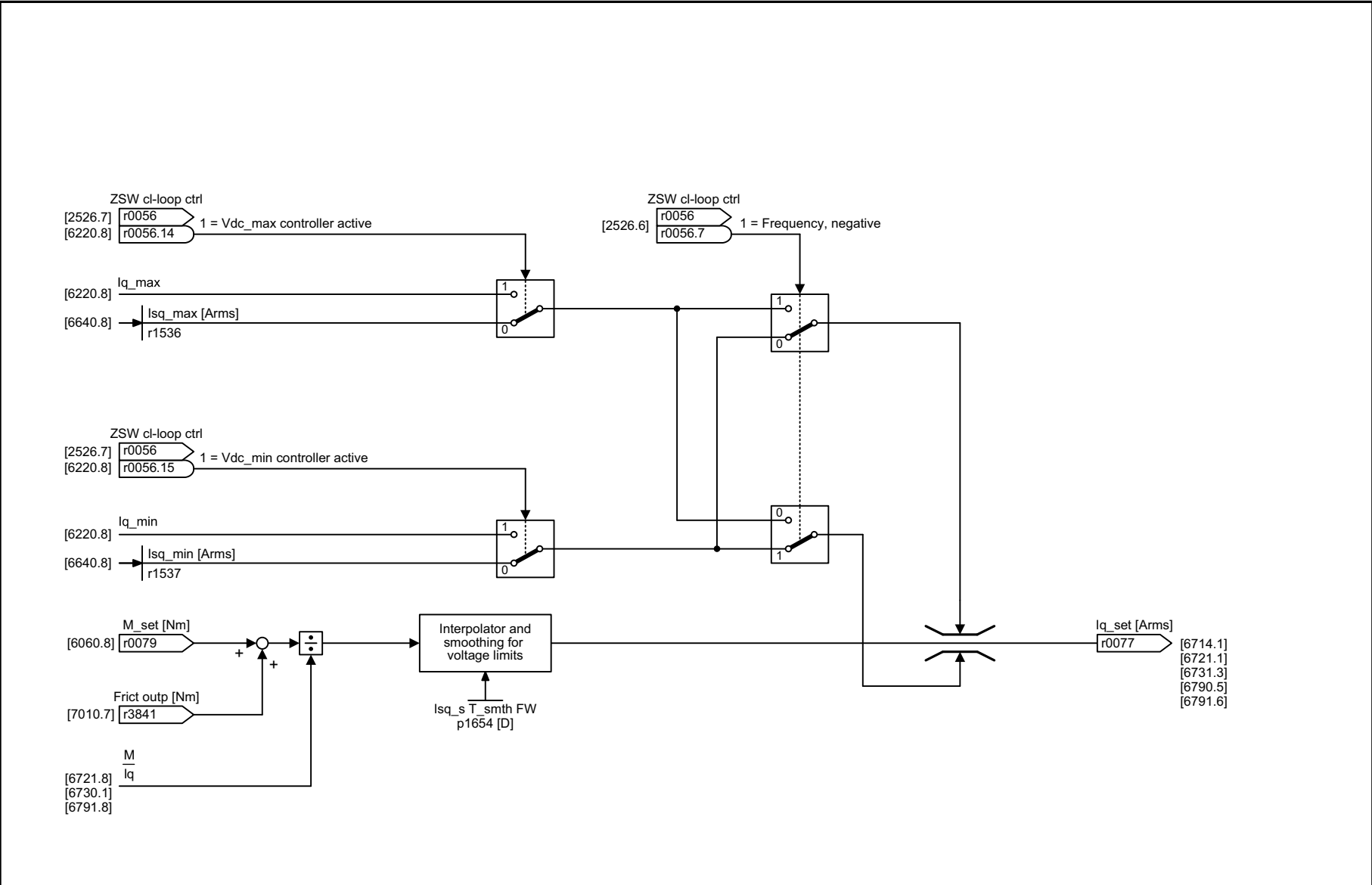
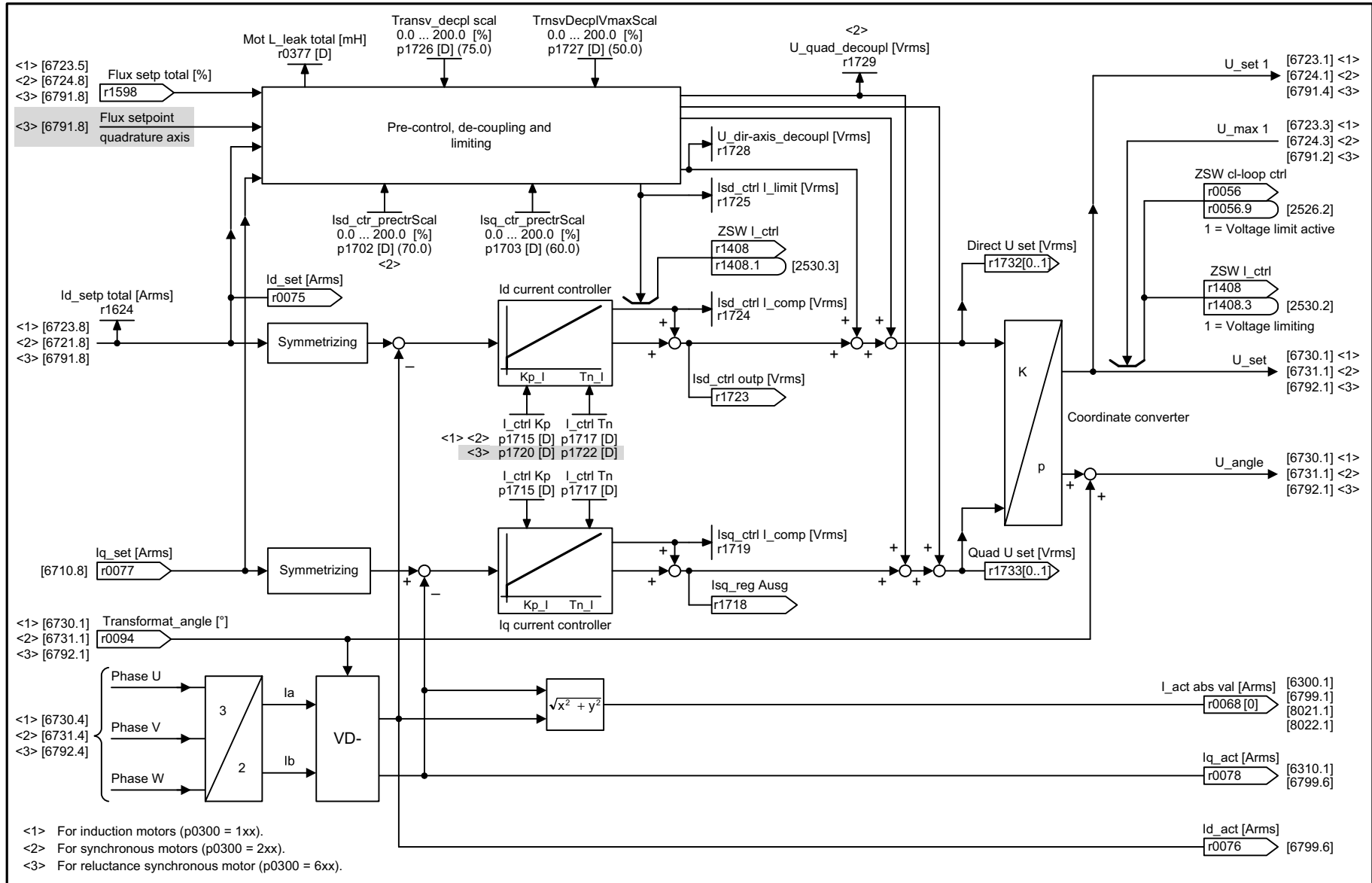

Fig. 3-94 6710 – Current setpoint filter

1	2	3	4	5	6	7	8
Vector control / U/f control					fp_6710_97_70.vsd	Function diagram	
Current setpoint filter					20.07.2021 V4.7_13	G115D	
							- 6710 -

Fig. 3-95 6714 – Iq and Id controllers



1	2	3	4	5	6	7	8
Vector control / U/f control					fp_6714_97_70.vsd	Function diagram	
Iq and Id controllers					20.07.2021 V4.7_13	G115D	
							- 6714 -

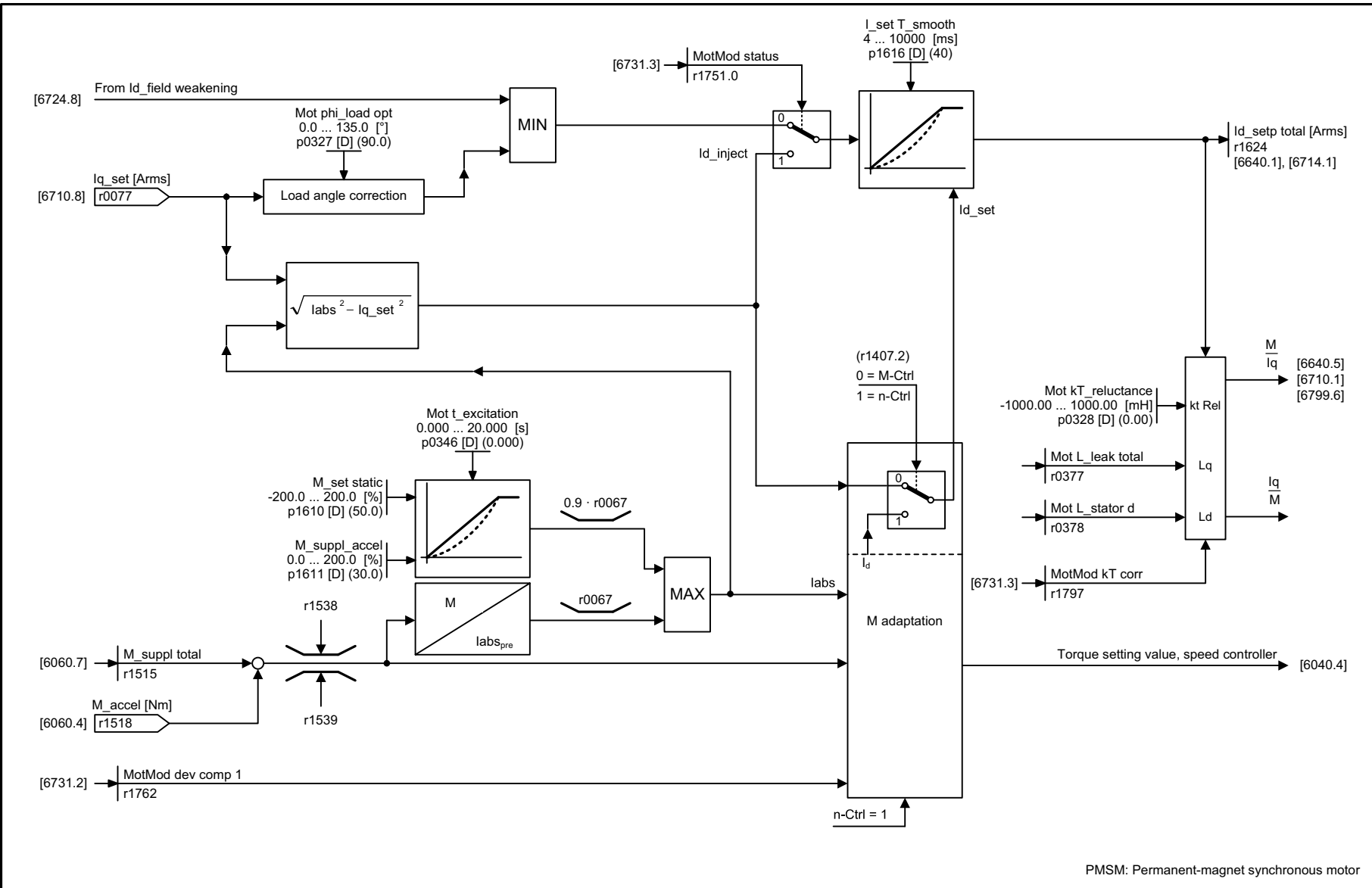

PMSM: Permanent-magnet synchronous motor

1	2	3	4	5	6	7	8
Vector control / U/f control					fp_6721_97_08.vsd	Function diagram	
Id setpoint (PMSM, p0300 = 2)					20.07.2021 V4.7_13	G115D	

- 6721 -

Fig. 3-96

6721 - Id setpoint (PMSM, p0300 = 2xx)

Fig. 3-97 6722 – Field weakening characteristic, flux setpoint (ASM, p0300 = 1)

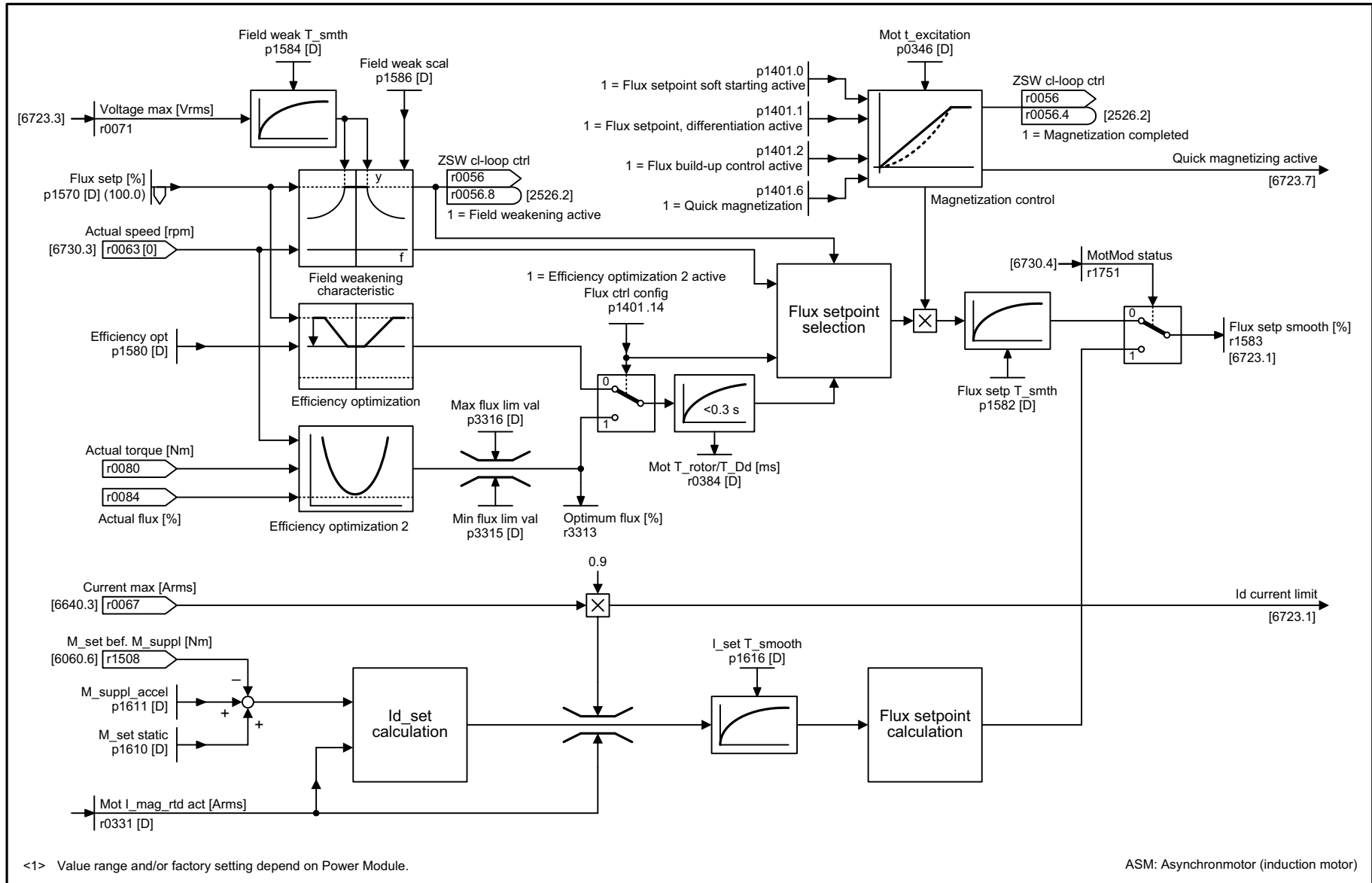

1	2	3	4	5	6	7	8
Vector control / U/f control					fp_6722_97_70.vsd	Function diagram	
Field weakening characteristic, flux setpoint (ASM, p0300 = 1xx)					20.07.2021 V4.7_13	G115D	
							- 6722 -

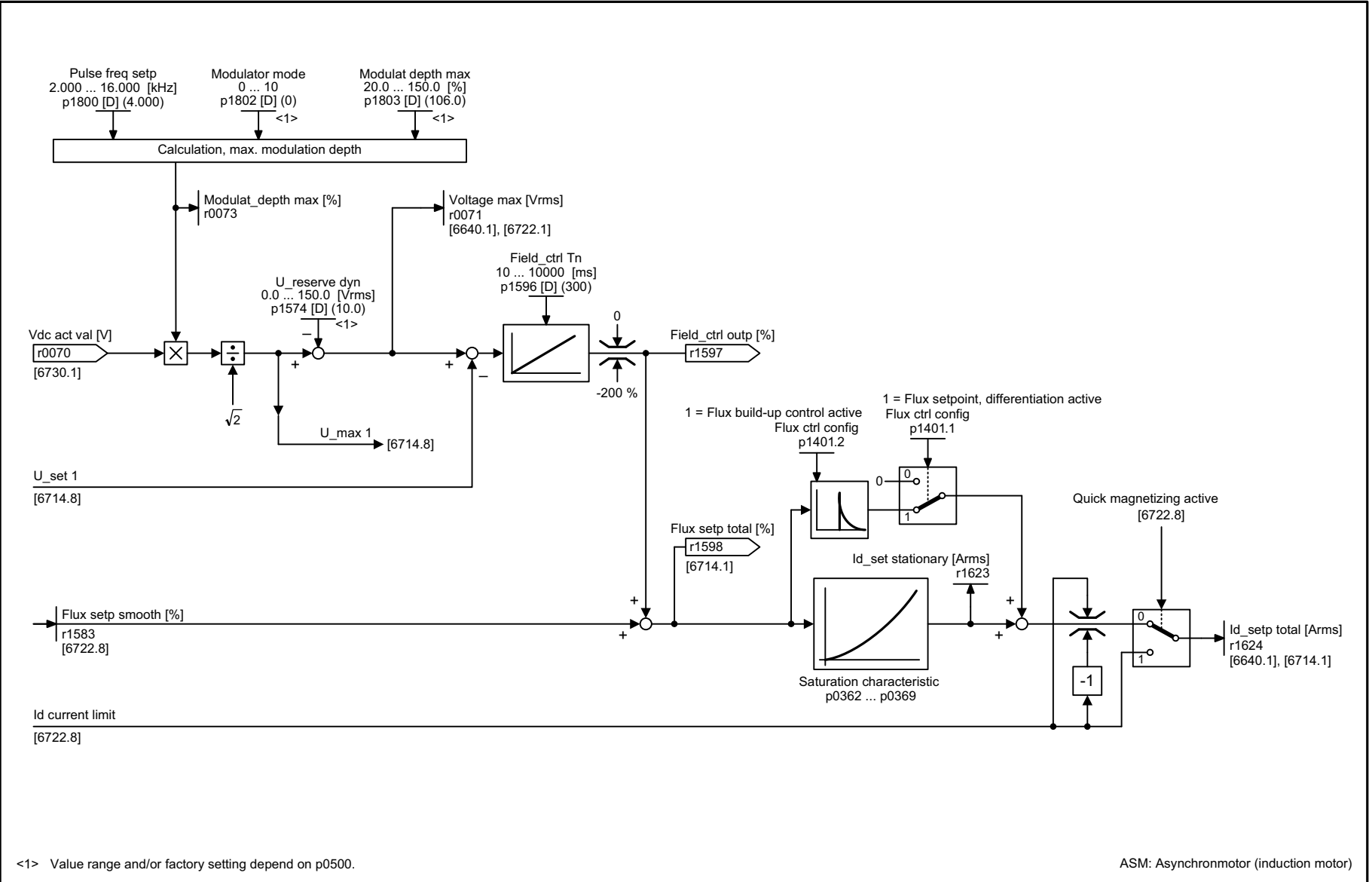

<1> Value range and/or factory setting depend on p0500.

1	2	3	4	5	6	7	8
Vector control / U/f control					fp_6723_97_53.vsd	Function diagram	
Field weakening controller, flux controller, Id setpoint (ASM, p0300 = 1xx)					20.07.2021 V4.7_13	G115D	

- 6723 -

Fig. 3-98 6723 – Field weakening controller, flux controller, Id setpoint (ASM, p0300 = 1)

Fig. 3-99 6724 – Field weakening controller (PMSM, p0300 = 2xx)

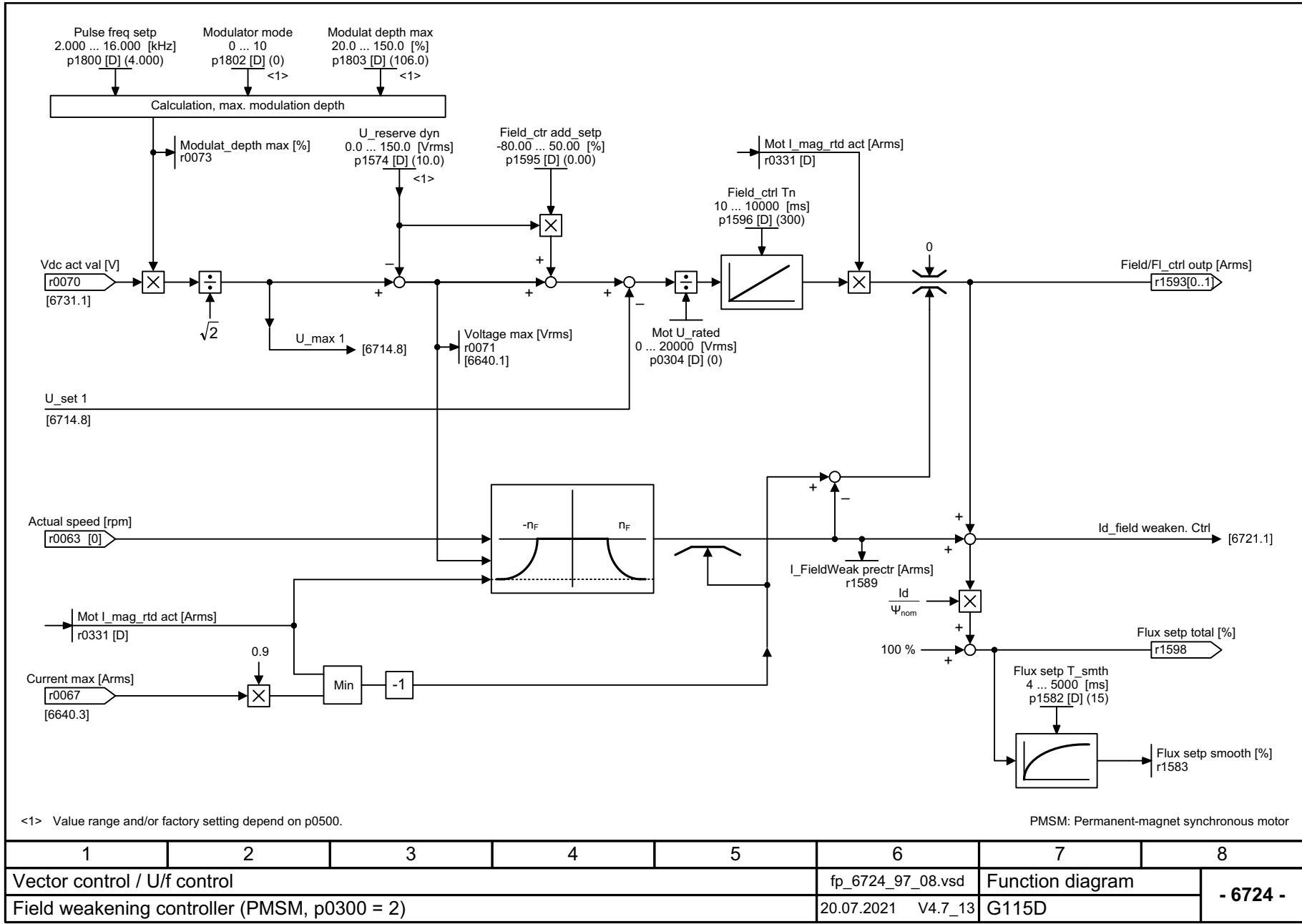

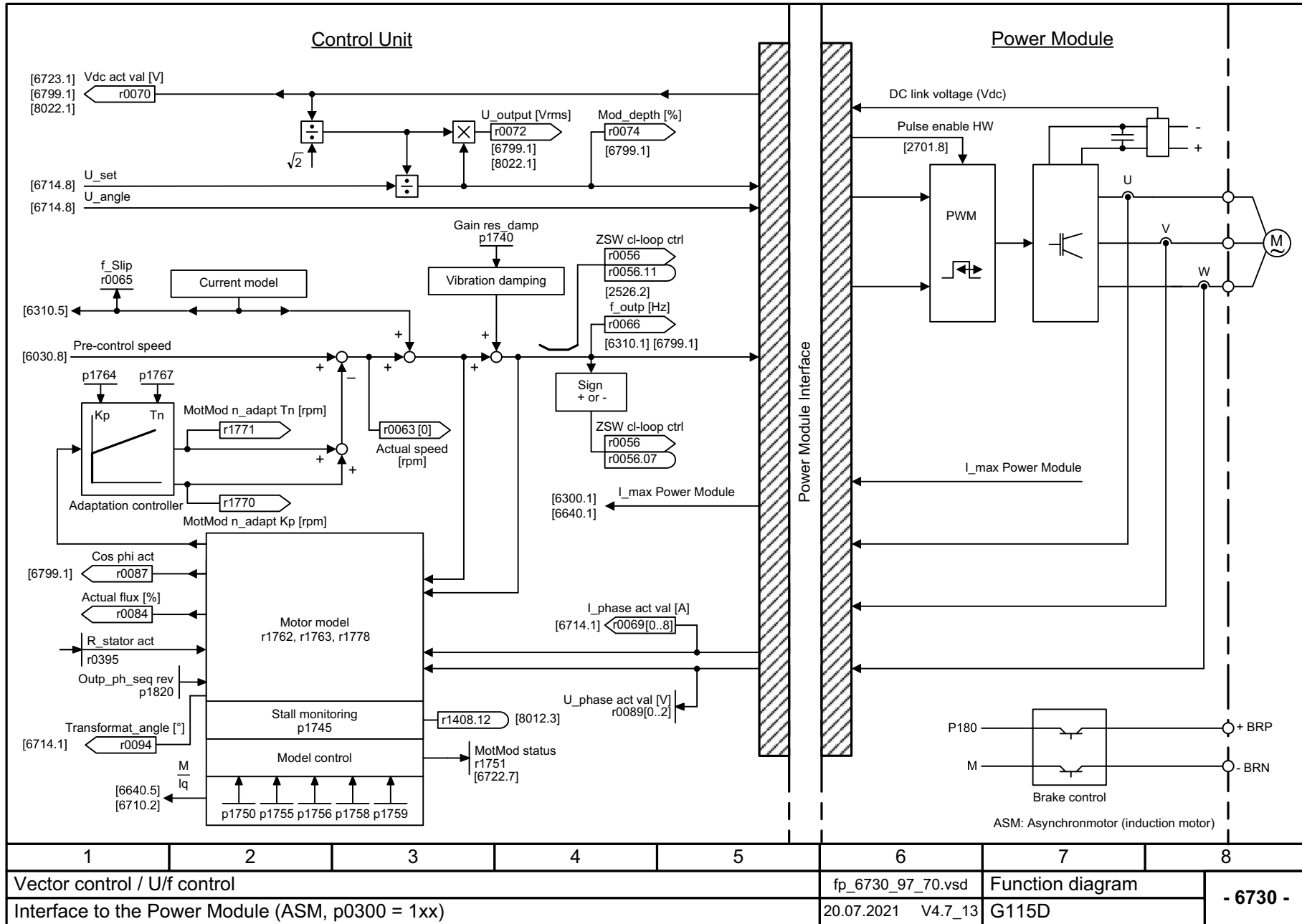
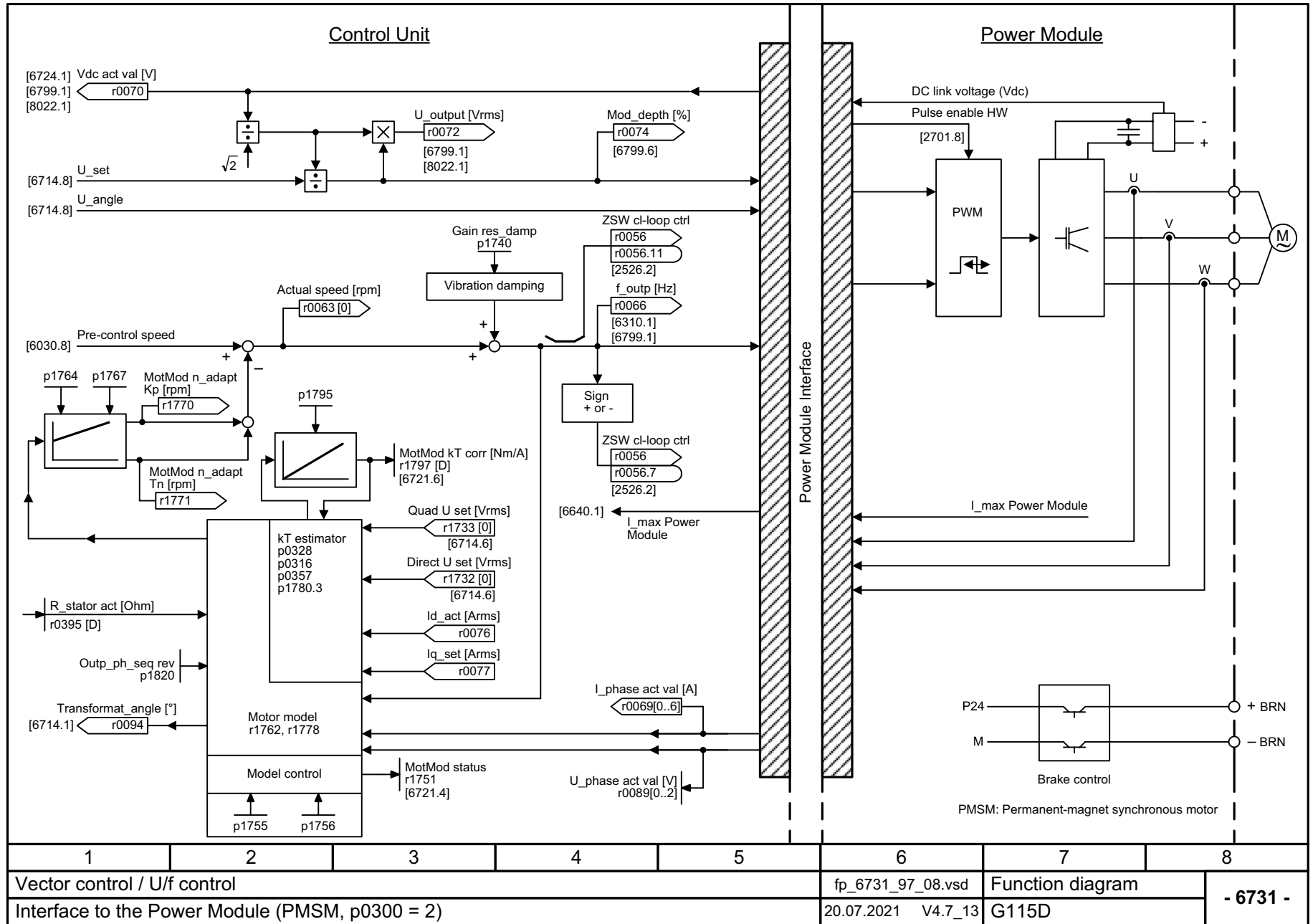
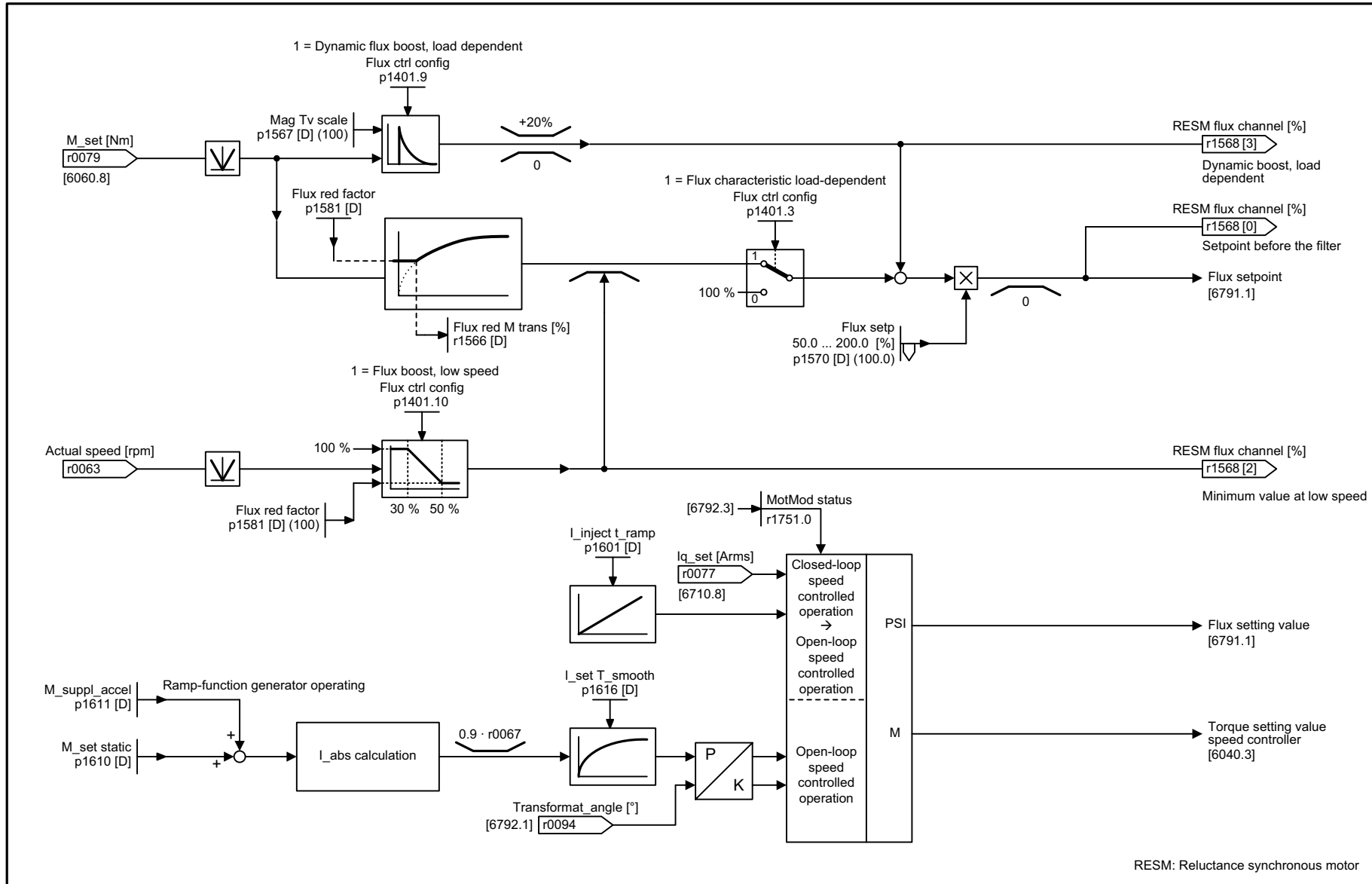

Fig. 3-100 6730 – Interface to the Power Module (ASM, p0300 = 1xx)

Fig. 3-101 6731 – Interface to the Power Module (PMSM, p0300 = 2xx)





1	2	3	4	5	6	7	8
Vector control / U/f control					fp_6790_97_57.vsd	Function diagram	
Flux setpoint (RESM, p0300 = 6xx)					20.07.2021 V4.7_13	G115D	
							- 6790 -

Fig. 3-102 6790 – Flux setpoint (RESM, p0300 = 6xx)

Fig. 3-103 6791 – Id setpoint (RESM, p0300 = 6xx)

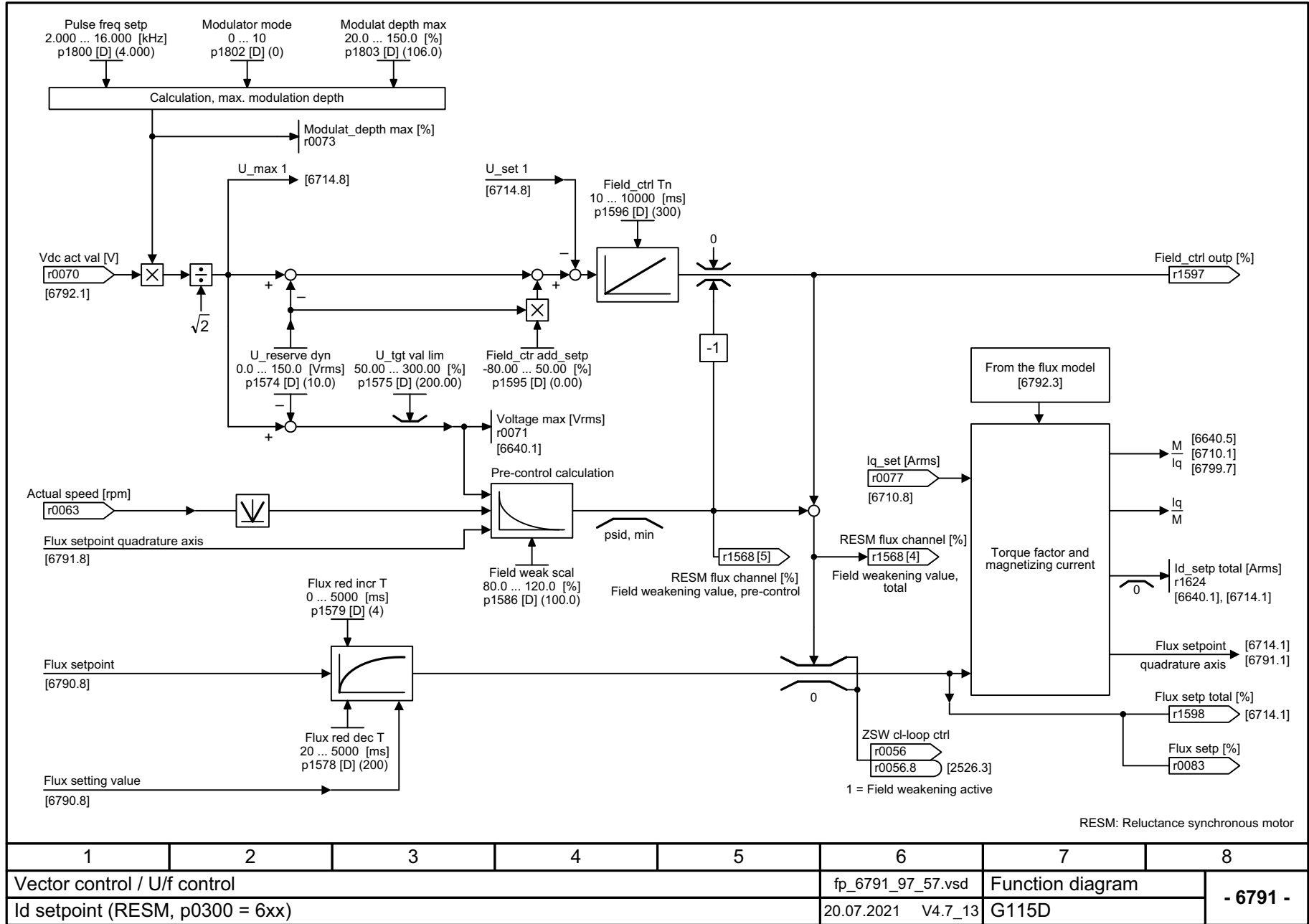

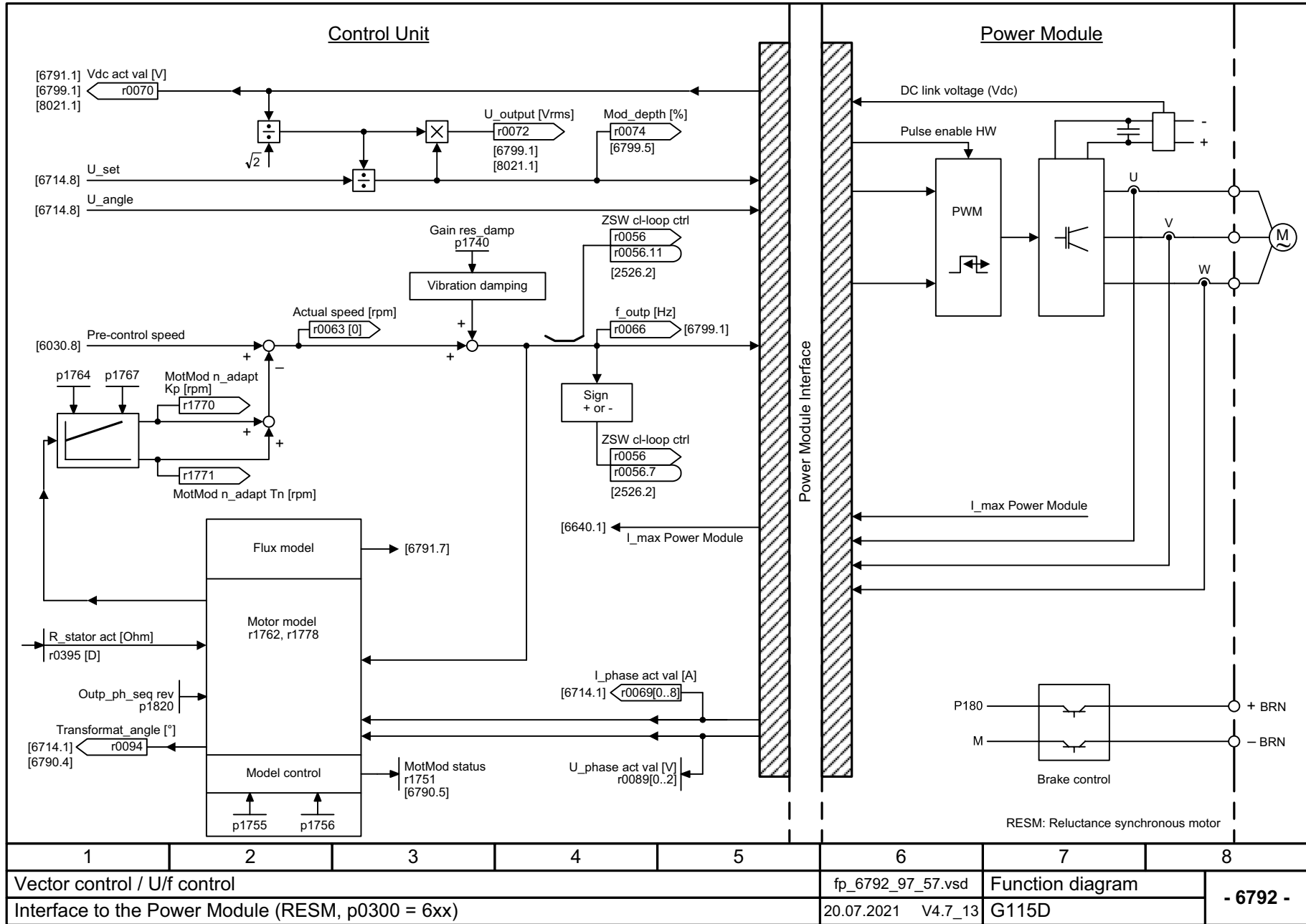
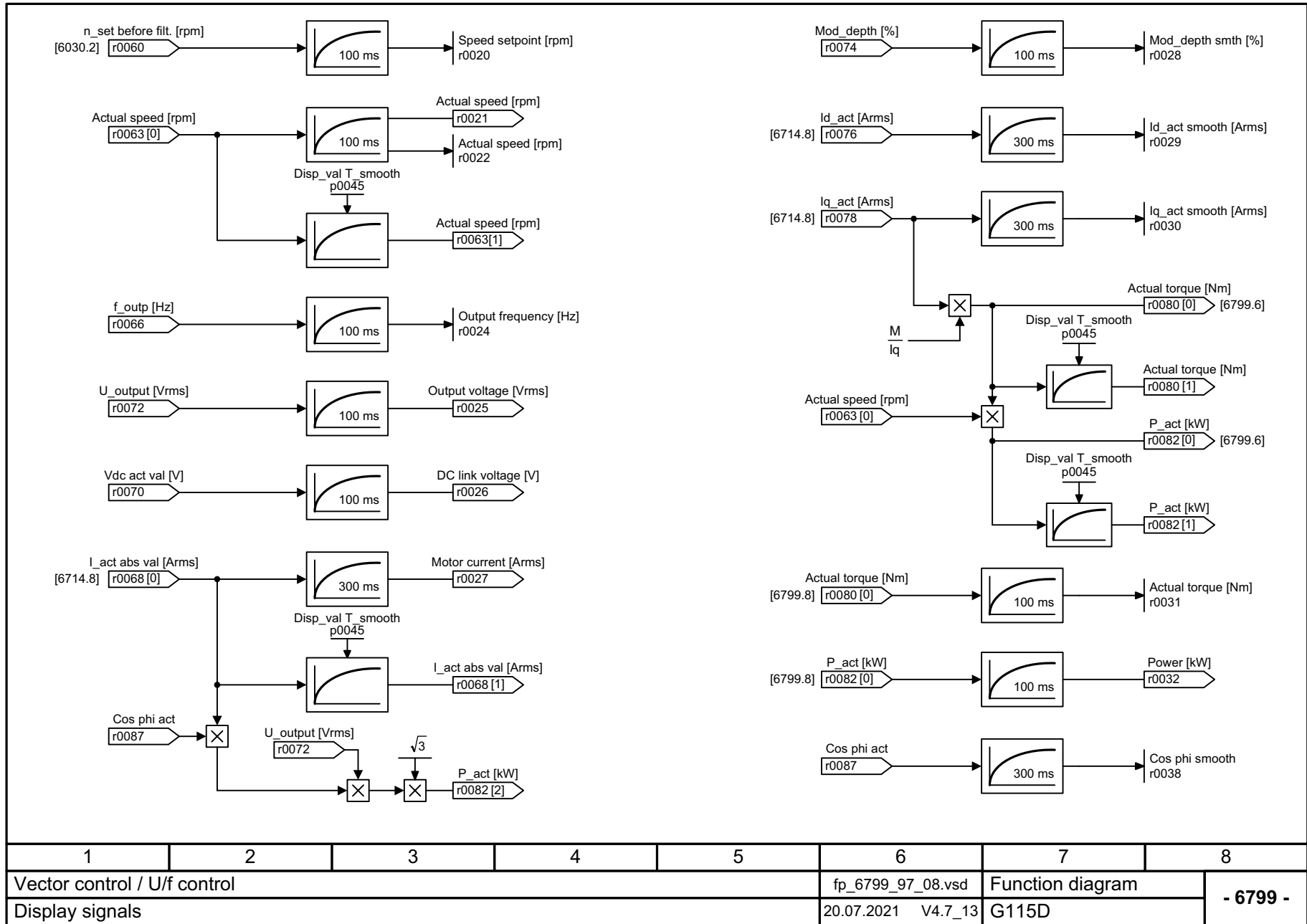

Fig. 3-104 6792 – Interface to the Power Module (RESM, p0300 = 6xx)

1	2	3	4	5	6	7	8
Vector control / U/f control					fp_6792_97_57.vsd	Function diagram	
Interface to the Power Module (RESM, p0300 = 6xx)					20.07.2021 V4.7_13	G115D	
							- 6792 -

Fig. 3-105 6799 – Display signals



1	2	3	4	5	6	7	8
Vector control / U/f control					fp_6799_97_08.vsd	Function diagram	
Display signals					20.07.2021 V4.7_13	G115D	
							- 6799 -

3.14 Technology functions

Function diagrams

7010 – Friction characteristic	617
7017 – DC braking (ASM, p0300 = 1)	618

Fig. 3-106 7010 – Friction characteristic

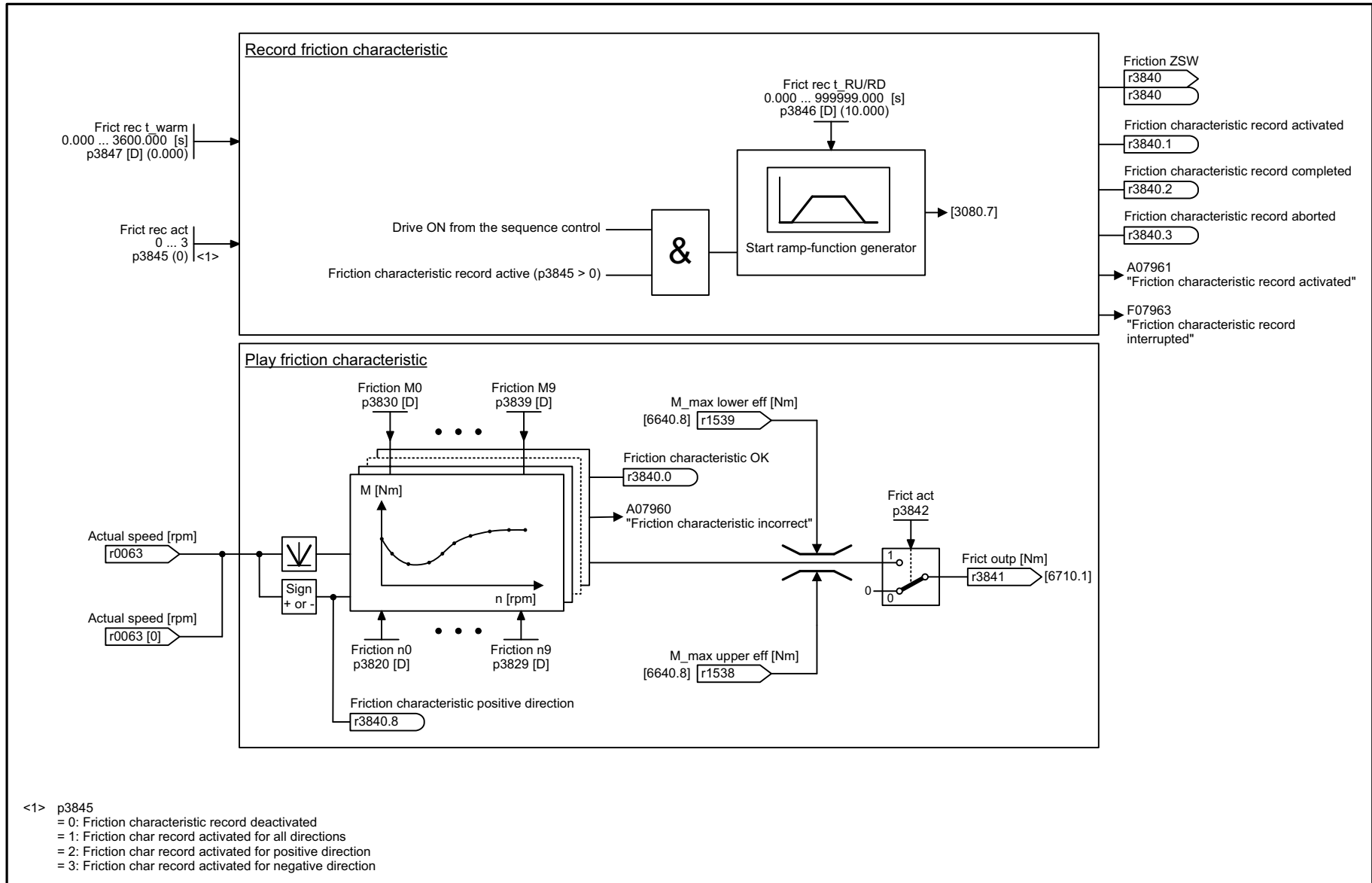

1	2	3	4	5	6	7	8
Technology functions					fp_7010_97_53.vsd	Function diagram	
Friction characteristic					20.07.2021 V4.7_13	G115D	
							- 7010 -

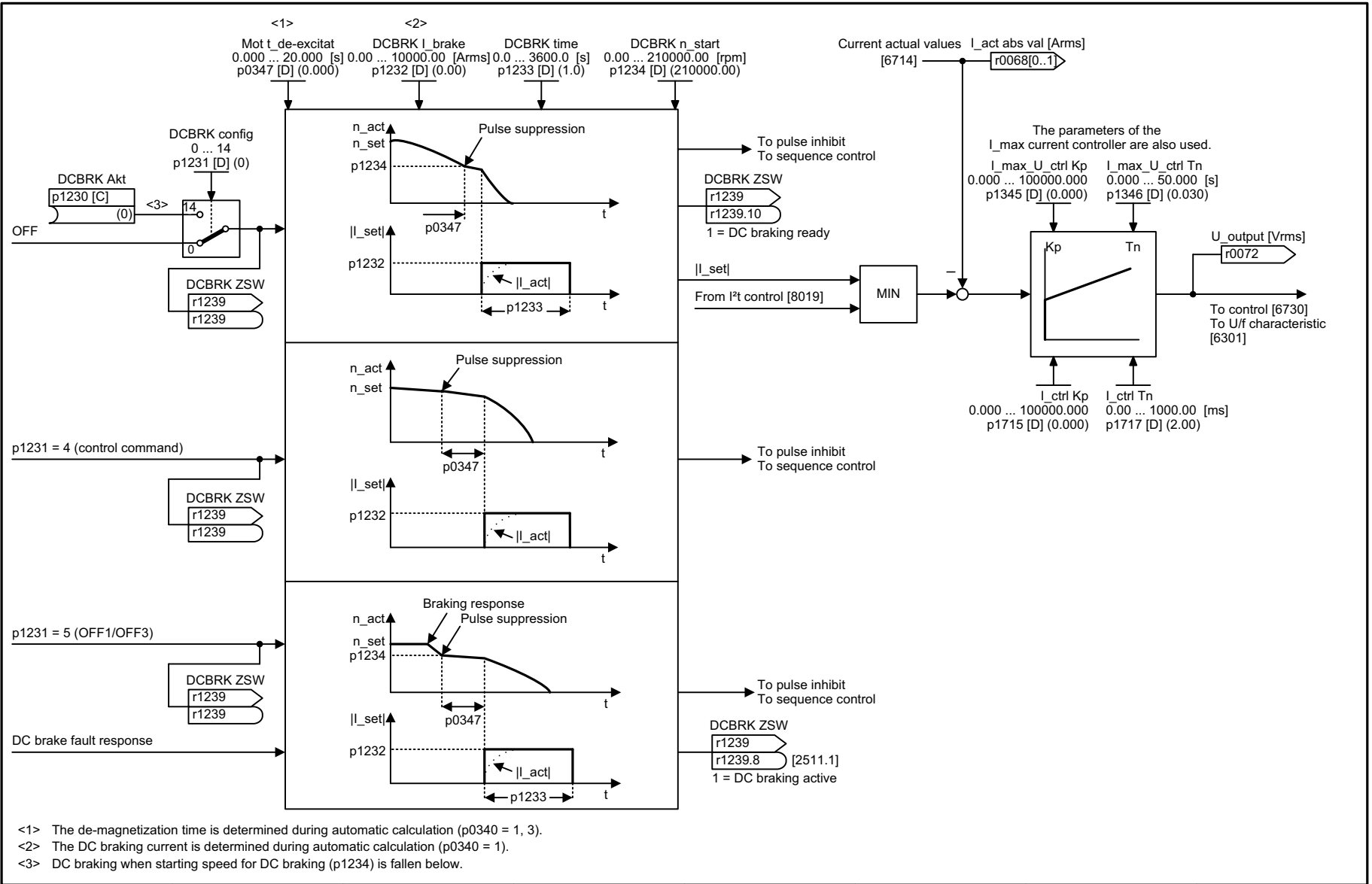

<1> The de-magnetization time is determined during automatic calculation (p0340 = 1, 3).
 <2> The DC braking current is determined during automatic calculation (p0340 = 1).
 <3> DC braking when starting speed for DC braking (p1234) is fallen below.

1	2	3	4	5	6	7	8
Technology functions					fp_7017_97_51.vsd	Function diagram	
DC braking (ASM, p0300 = 1xx)					20.07.2021 V4.7_13	G115D	
							- 7017 -

Fig. 3-107 7017 – DC braking (ASM, p0300 = 1)

3.15 Conveyor technology applications

Function diagrams

7040 – Conveyor, 1 Direction / 1 Speed (p3393 = 1)	620
7041 – Conveyor, 1 Direction / 2 Speeds (p3393 = 2)	621
7042 – Conveyor, 2 Directions / 1 Speed (p3393 = 3)	622
7043 – Conveyor, 2 Directions / 2 Speeds (p3393 = 4)	623
7044 – Turntable, 2 Positions / 1 Speed (p3393 = 5)	624
7045 – Turntable, 2 Positions / 2 Speeds (p3393 = 6)	625
7046 – Turntable, 3 Positions / 1 Speed (p3393 = 7)	626
7047 – Turntable, 3 Positions / 2 Speeds (p3393 = 8)	627
7048 – Corner turntable lift, 2 Positions / 1 Speed (p3393 = 9)	628
7049 – Corner turntable lift, 2 Positions / 2 Speeds (p3393 = 10)	629
7050 – Travelling Trolley, 1 Speed (p3393 = 11)	630
7051 – Travelling Trolley, 2 Speeds (p3393 = 12)	631

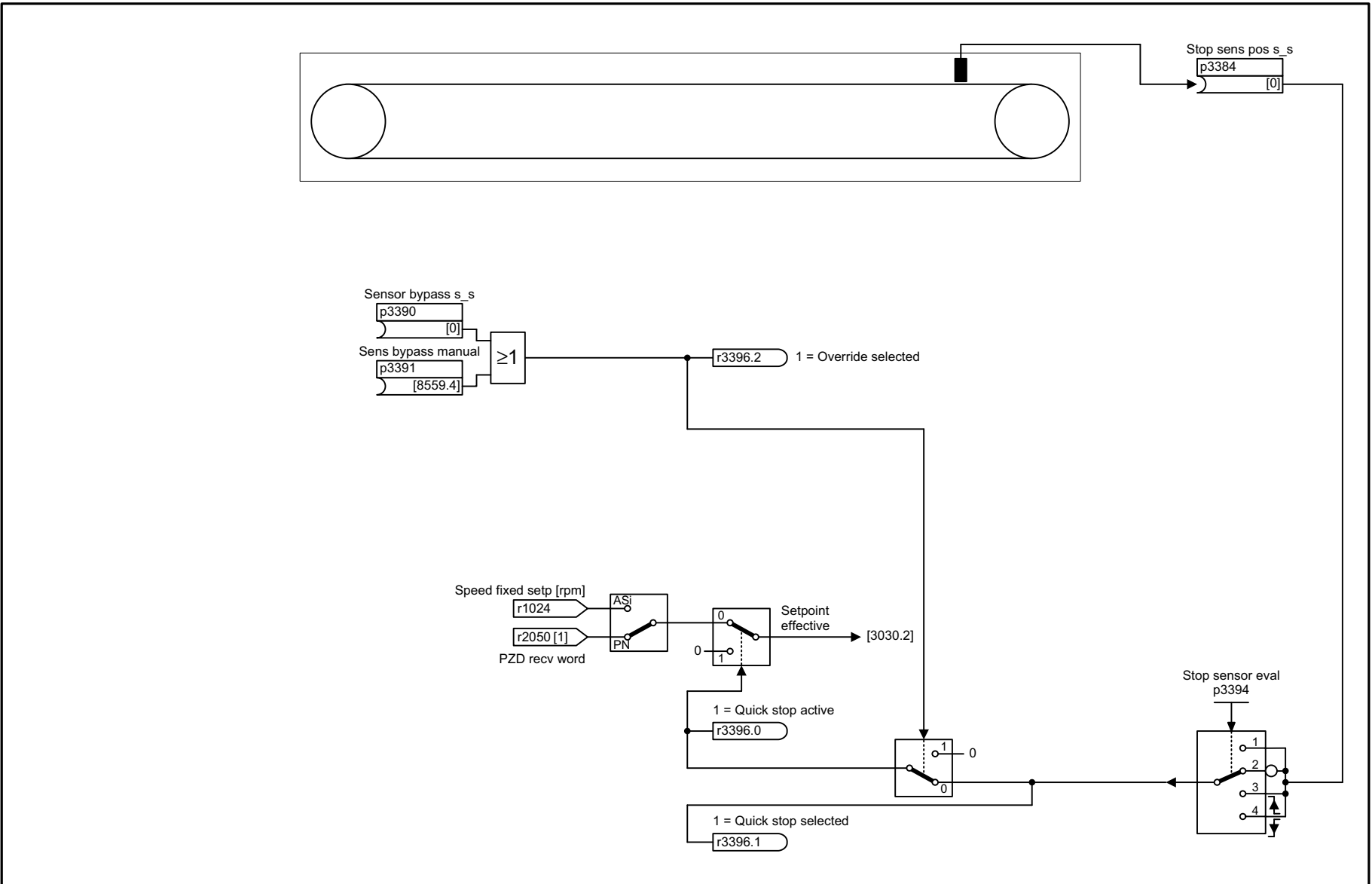
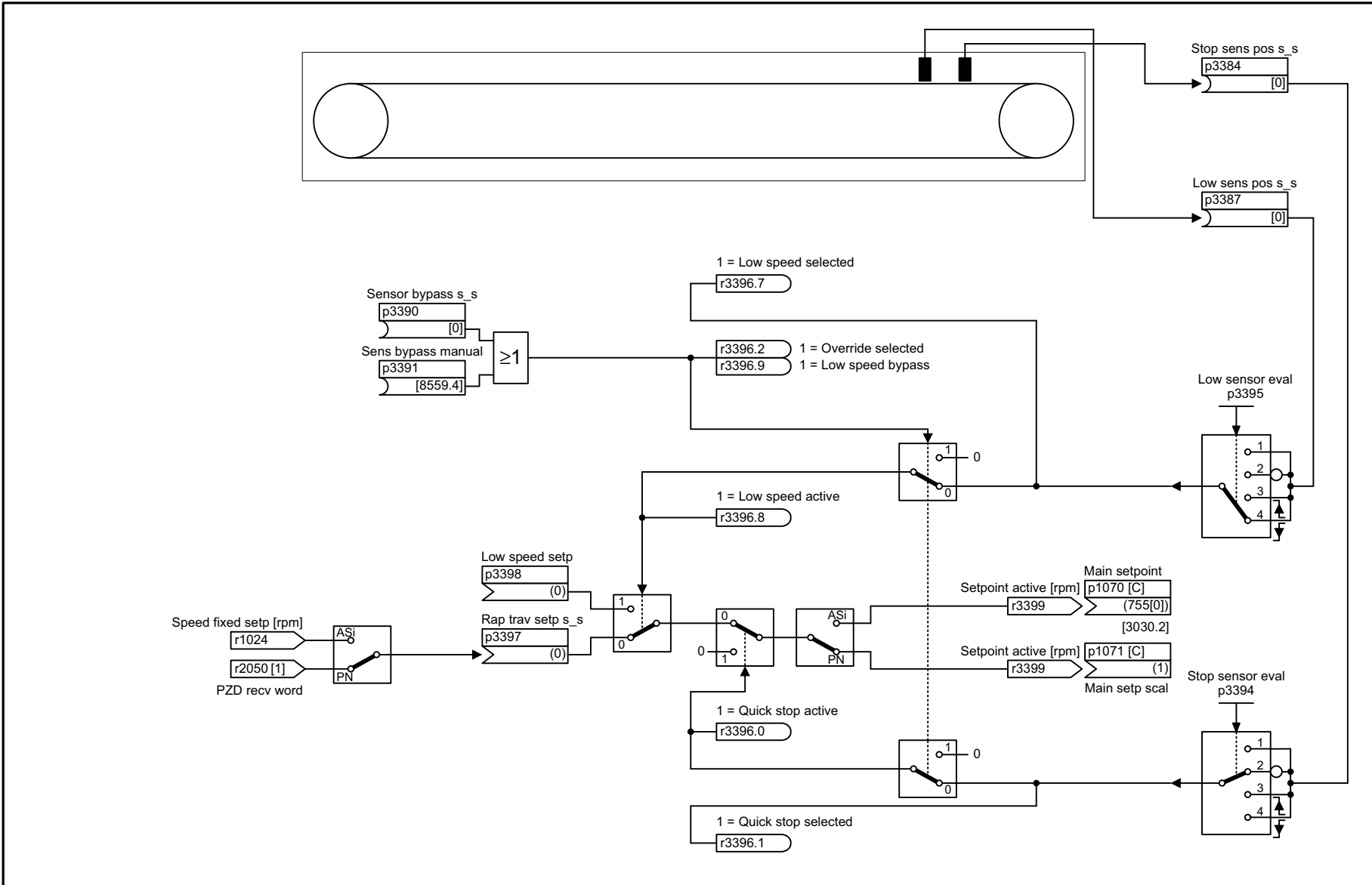

Fig. 3-108 7040 – Conveyor, 1 Direction / 1 Speed (p3393 = 1)

1	2	3	4	5	6	7	8
Conveying applications					fp_7040_97_08.vsd	Function diagram	
Conveyor, 1 Direction / 1 Speed (p3393 = 1)					20.07.2021 V4.7_13	G115D	
							- 7040 -



1	2	3	4	5	6	7	8
Conveying applications					fp_7041_97_08.vsd	Function diagram	
Conveyor, 1 Direction / 2 Speeds (p3393 = 2)					20.07.2021 V4.7_13	G115D	
							- 7041 -

Fig. 3-109 7041 – Conveyor, 1 Direction / 2 Speeds (p3393 = 2)

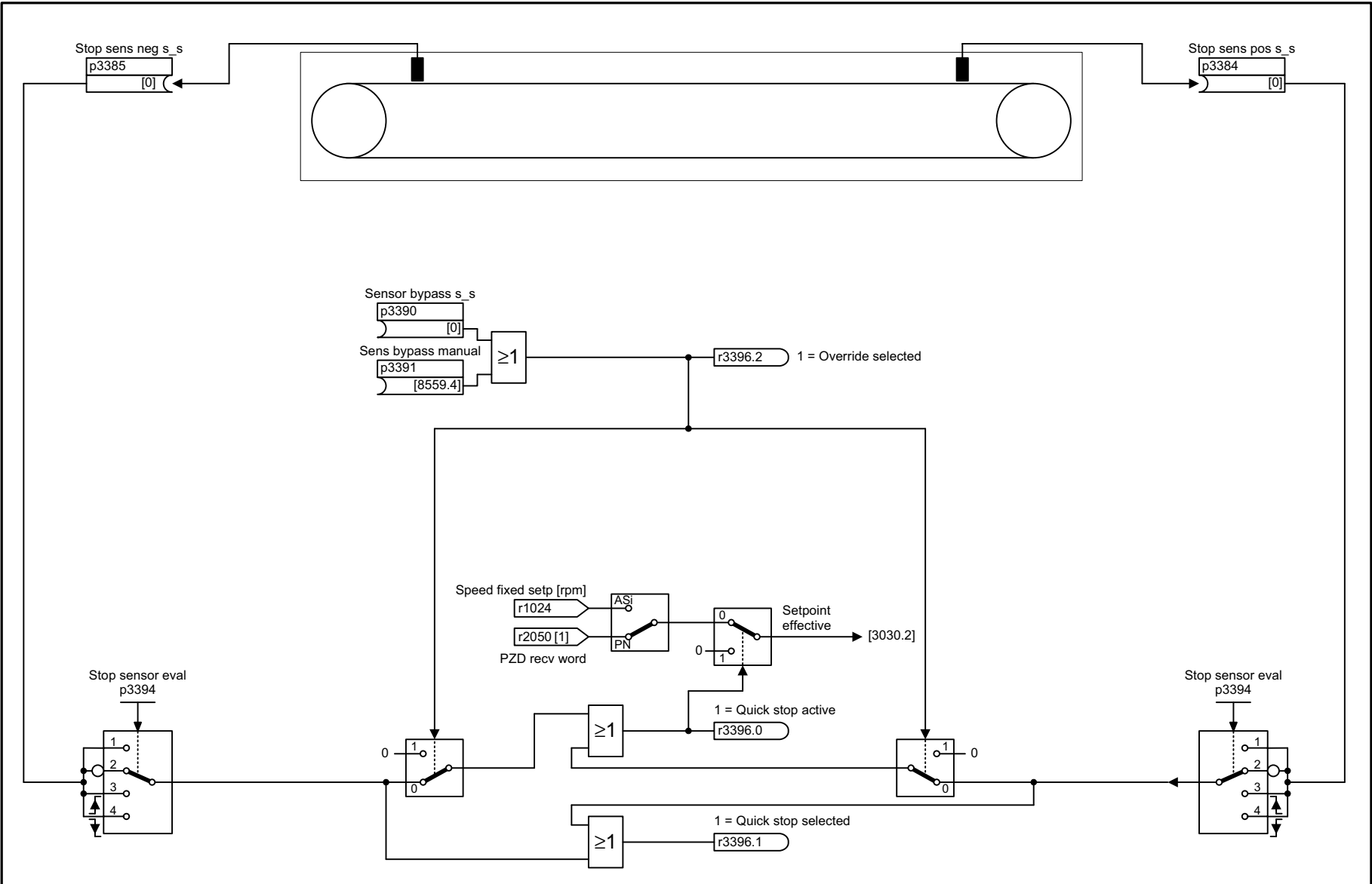
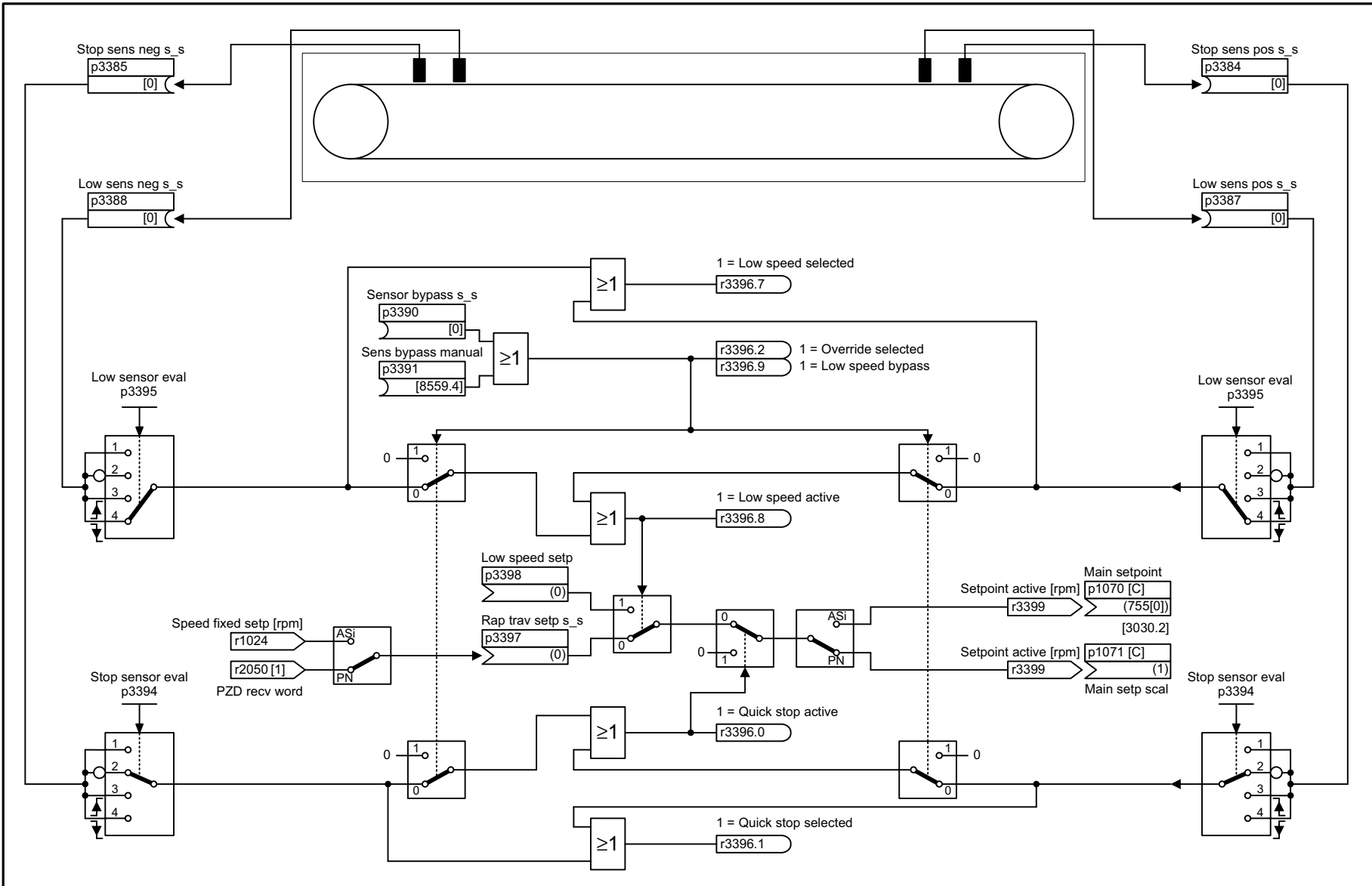

Fig. 3-110 7042 – Conveyor, 2 Directions / 1 Speed (p3393 = 3)

1	2	3	4	5	6	7	8
Conveying applications					fp_7042_97_08.vsd	Function diagram	
Conveyor, 2 Directions / 1 Speed (p3393 = 3)					20.07.2021 V4.7_13	G115D	
- 7042 -							



1	2	3	4	5	6	7	8
Conveying applications					fp_7043_97_08.vsd	Function diagram	
Conveyor, 2 Directions / 2 Speeds (p3393 = 4)					20.07.2021 V4.7_13	G115D	
- 7043 -							

Fig. 3-111 7043 – Conveyor, 2 Directions / 2 Speeds (p3393 = 4)

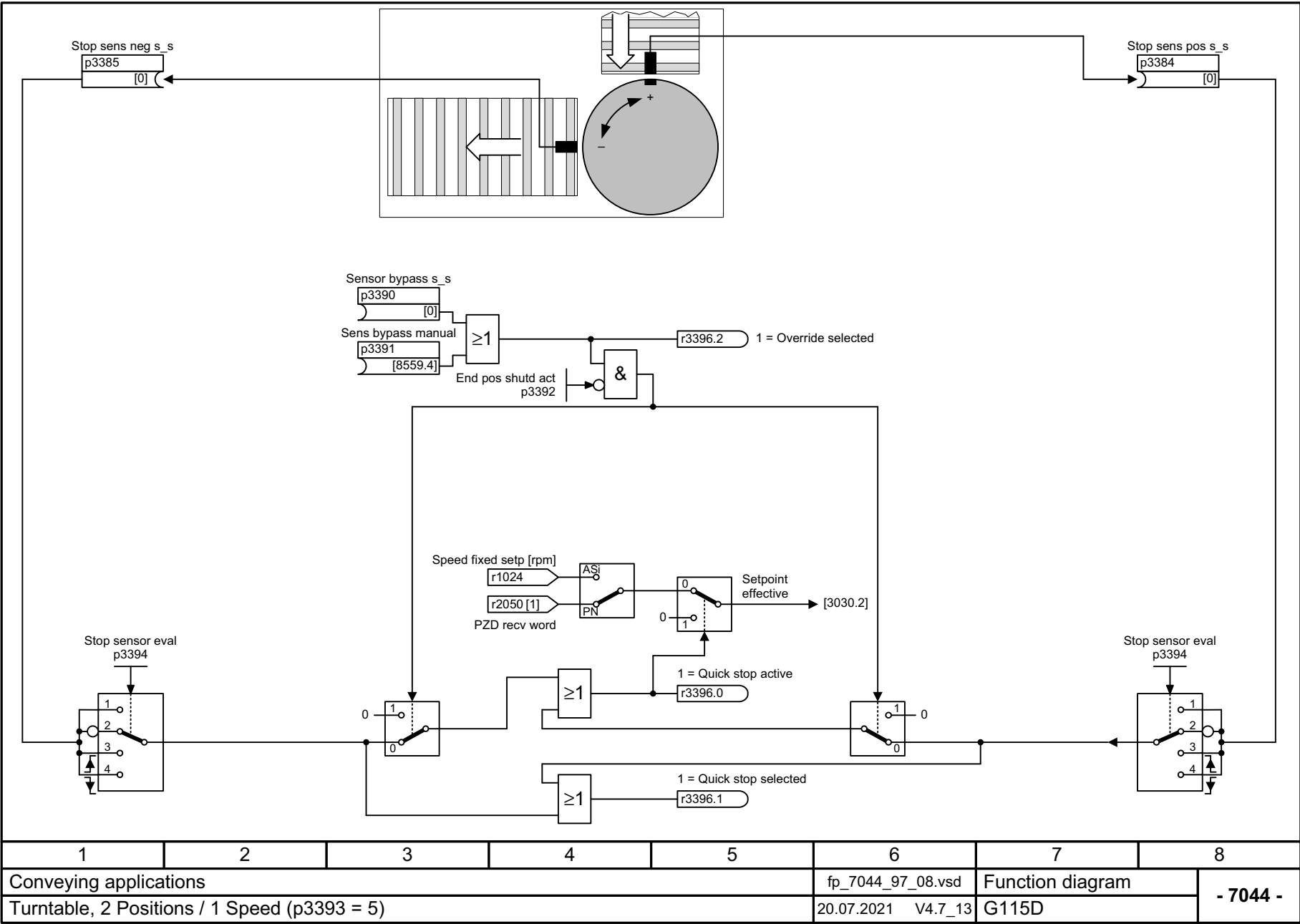
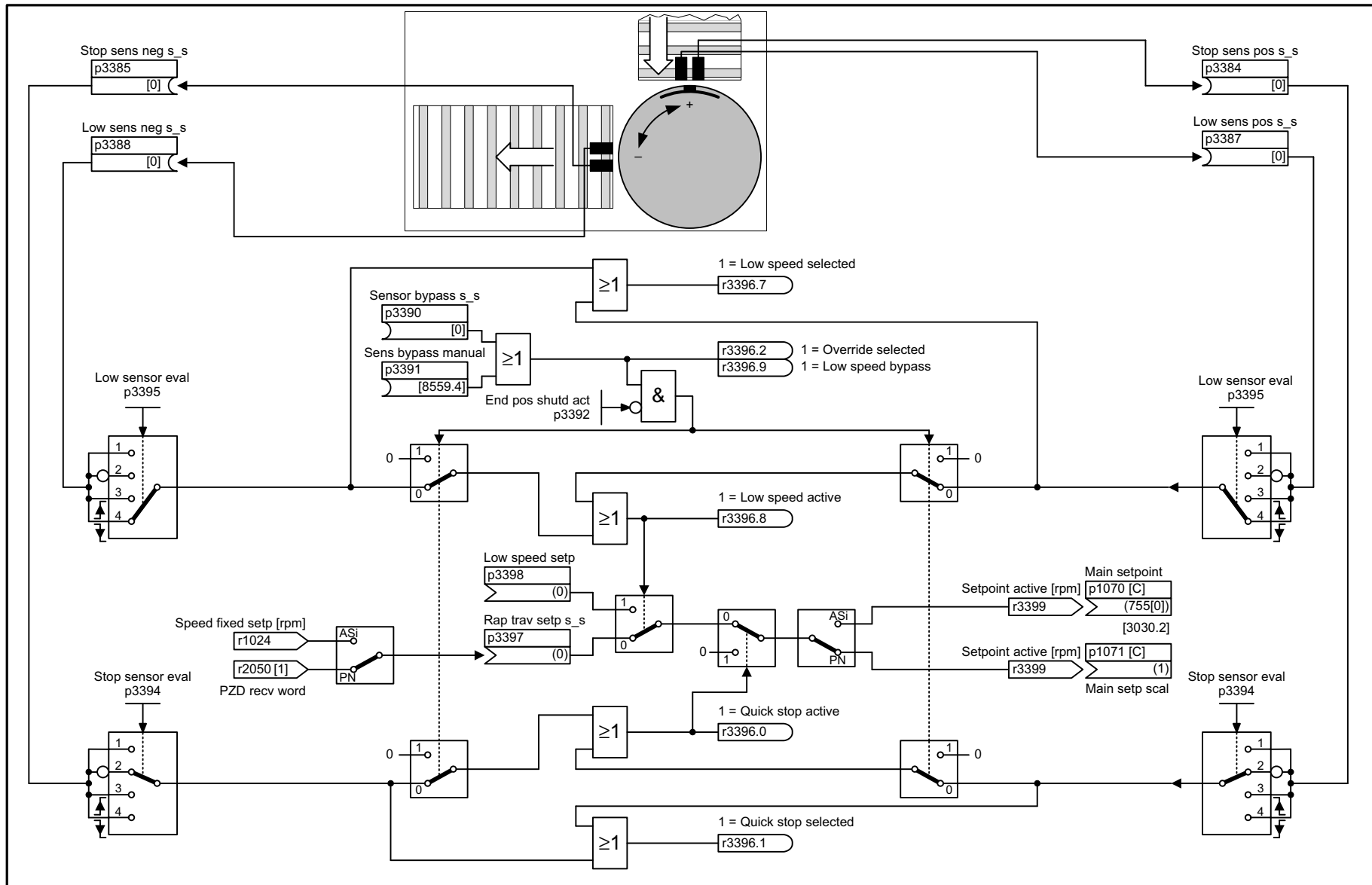

Fig. 3-112 7044 – Turntable, 2 Positions / 1 Speed (p3393 = 5)



1	2	3	4	5	6	7	8
Conveying applications					fp_7045_97_08.vsd	Function diagram	
Turntable, 2 Positions / 2 Speeds (p3393 = 6)					20.07.2021 V4.7_13	G115D	

- 7045 -

Fig. 3-113 7045 – Turntable, 2 Positions / 2 Speeds (p3393 = 6)

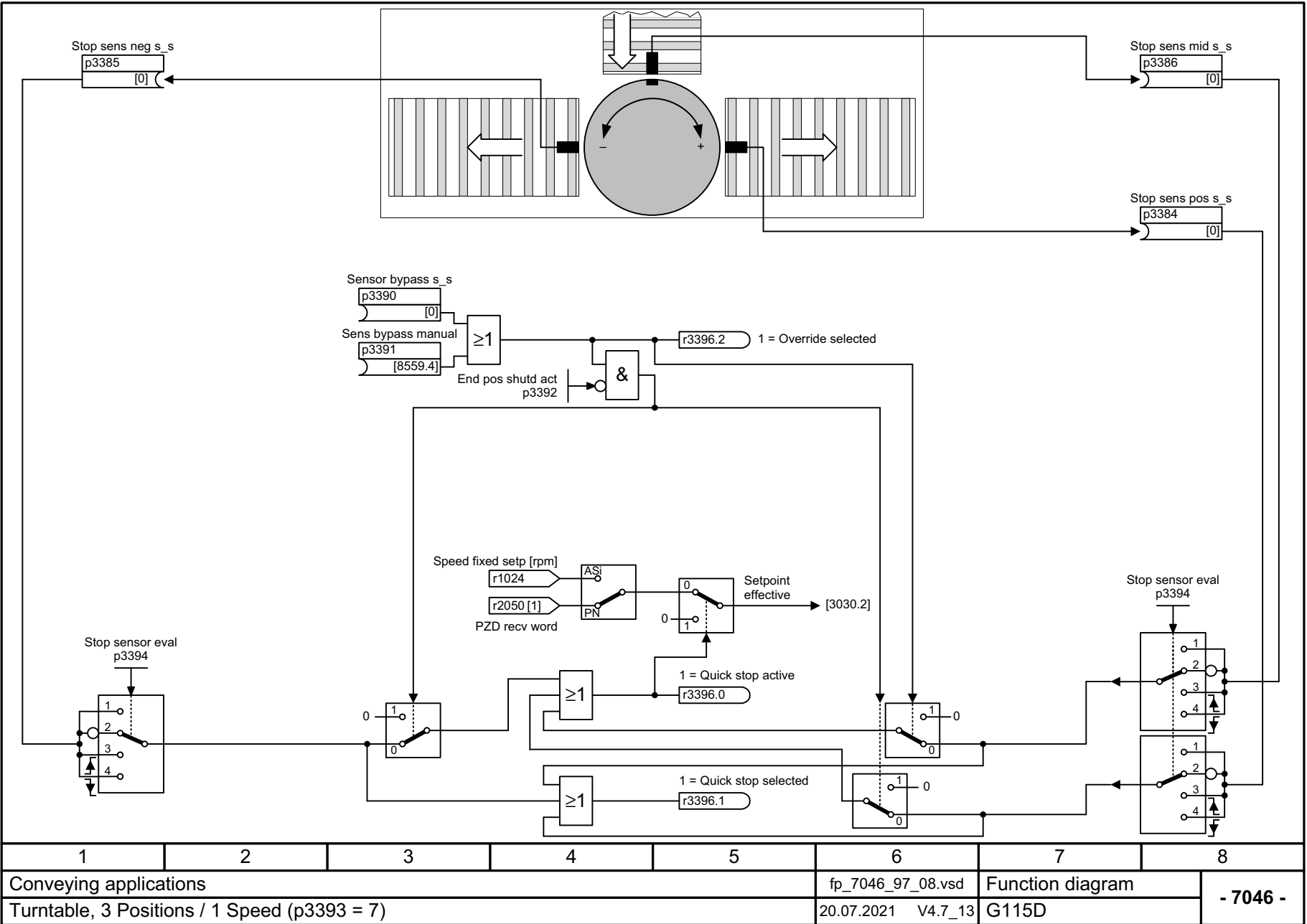
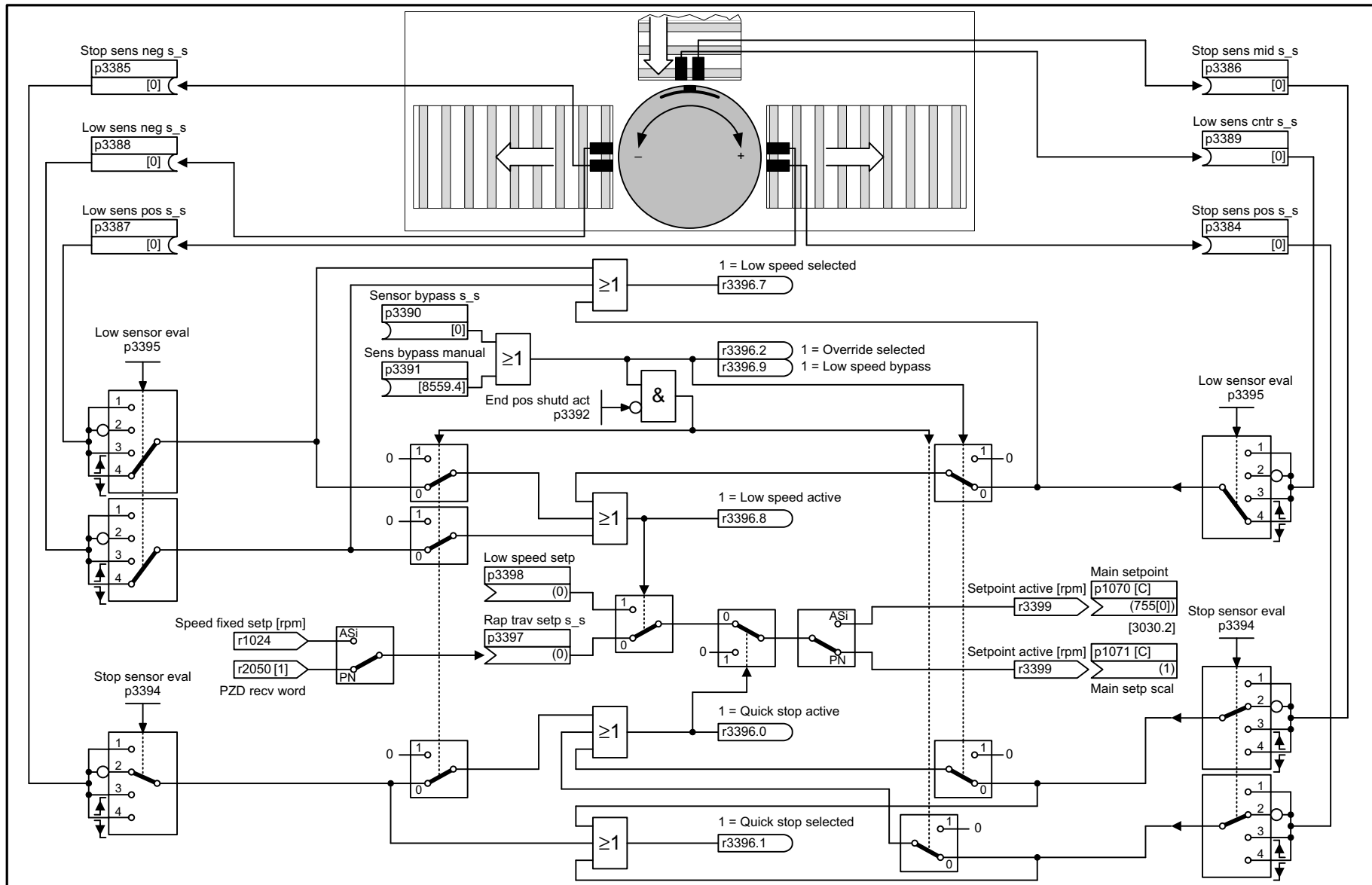

Fig. 3-114 7046 – Turntable, 3 Positions / 1 Speed (p3393 = 7)



1	2	3	4	5	6	7	8
Conveying applications					fp_7047_97_08.vsd	Function diagram	
Turntable, 3 Positions / 2 Speeds (p3393 = 8)					20.07.2021 V4.7_13	G115D	
- 7047 -							

Fig. 3-115 7047 – Turntable, 3 Positions / 2 Speeds (p3393 = 8)

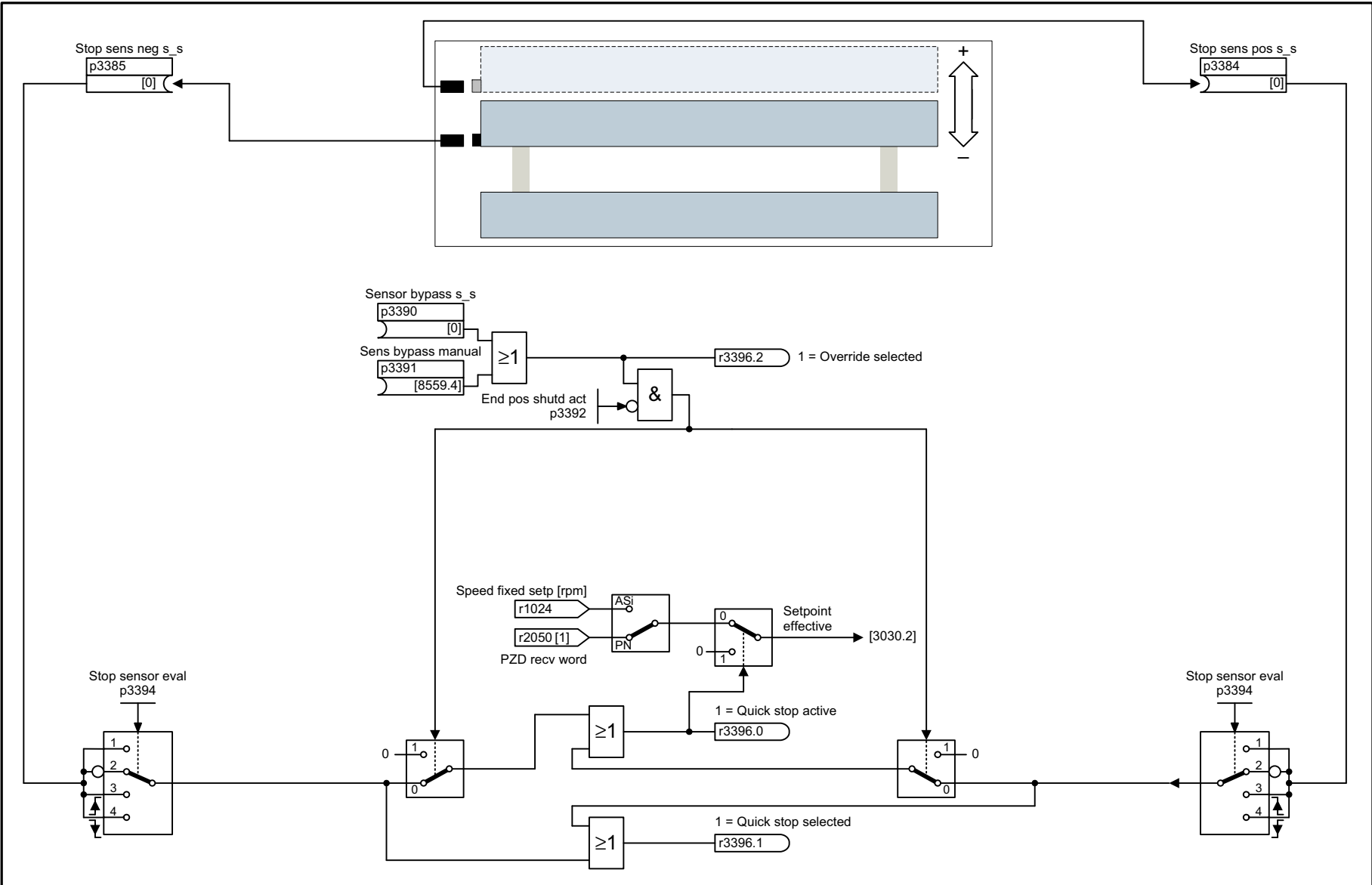
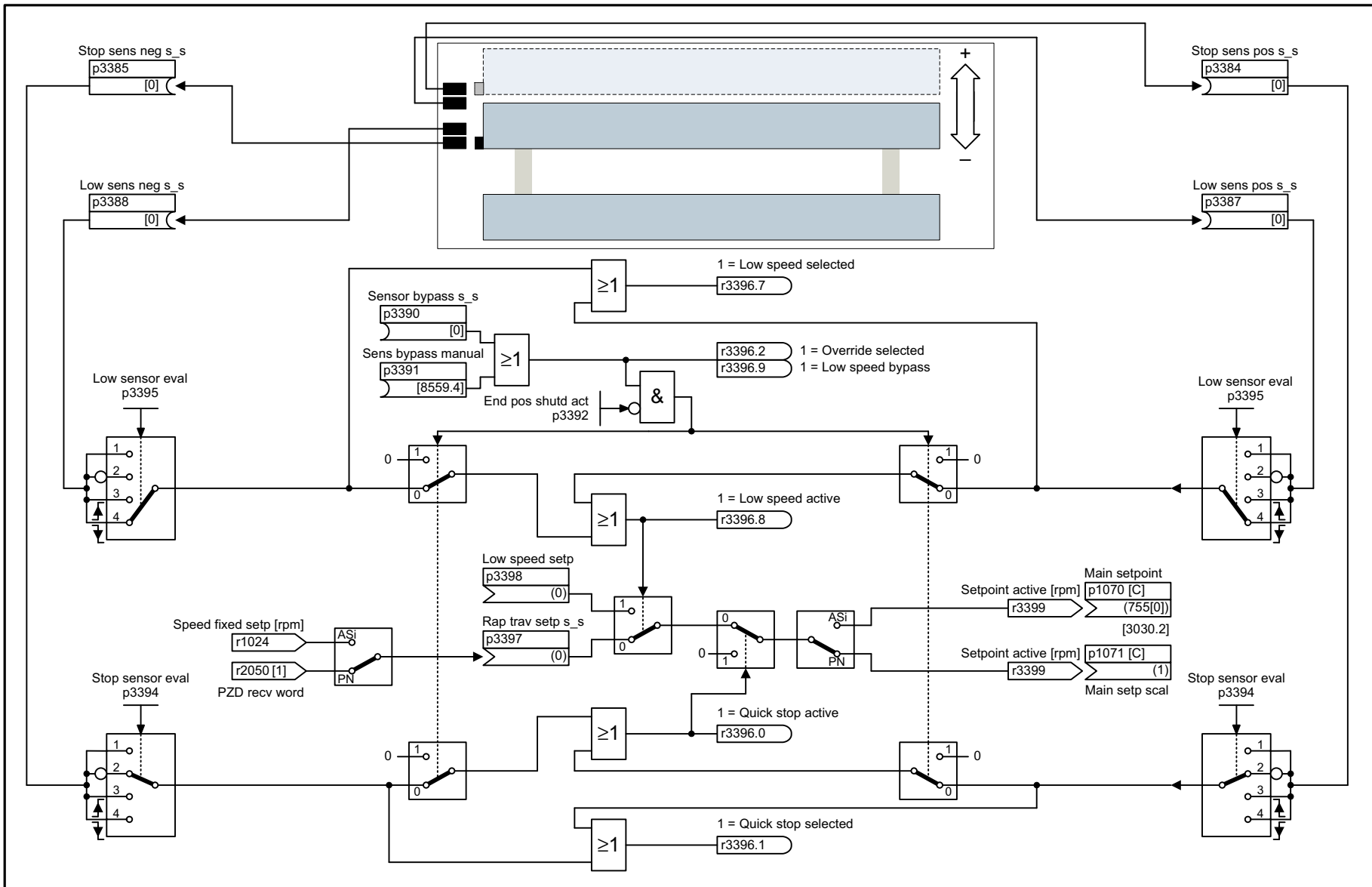

Fig. 3-116 7048 – Corner turntable lift, 2 Positions / 1 Speed (p3393 = 9)

1	2	3	4	5	6	7	8
Conveying applications					fp_7048_97_08.vsd	Function diagram	
Corner Turntable Lift, 2 Positions / 1 Speed (p3393 = 9)					20.07.2021 V4.7_13	G115D	
							- 7048 -



1	2	3	4	5	6	7	8
Conveying applications					fp_7049_97_08.vsd	Function diagram	
Corner Turntable Lift, 2 Positions / 2 Speeds (p3393 = 10)					20.07.2021 V4.7_13	G115D	
							- 7049 -

Fig. 3-117 7049 – Corner turntable lift, 2 Positions / 2 Speeds (p3393 = 10)

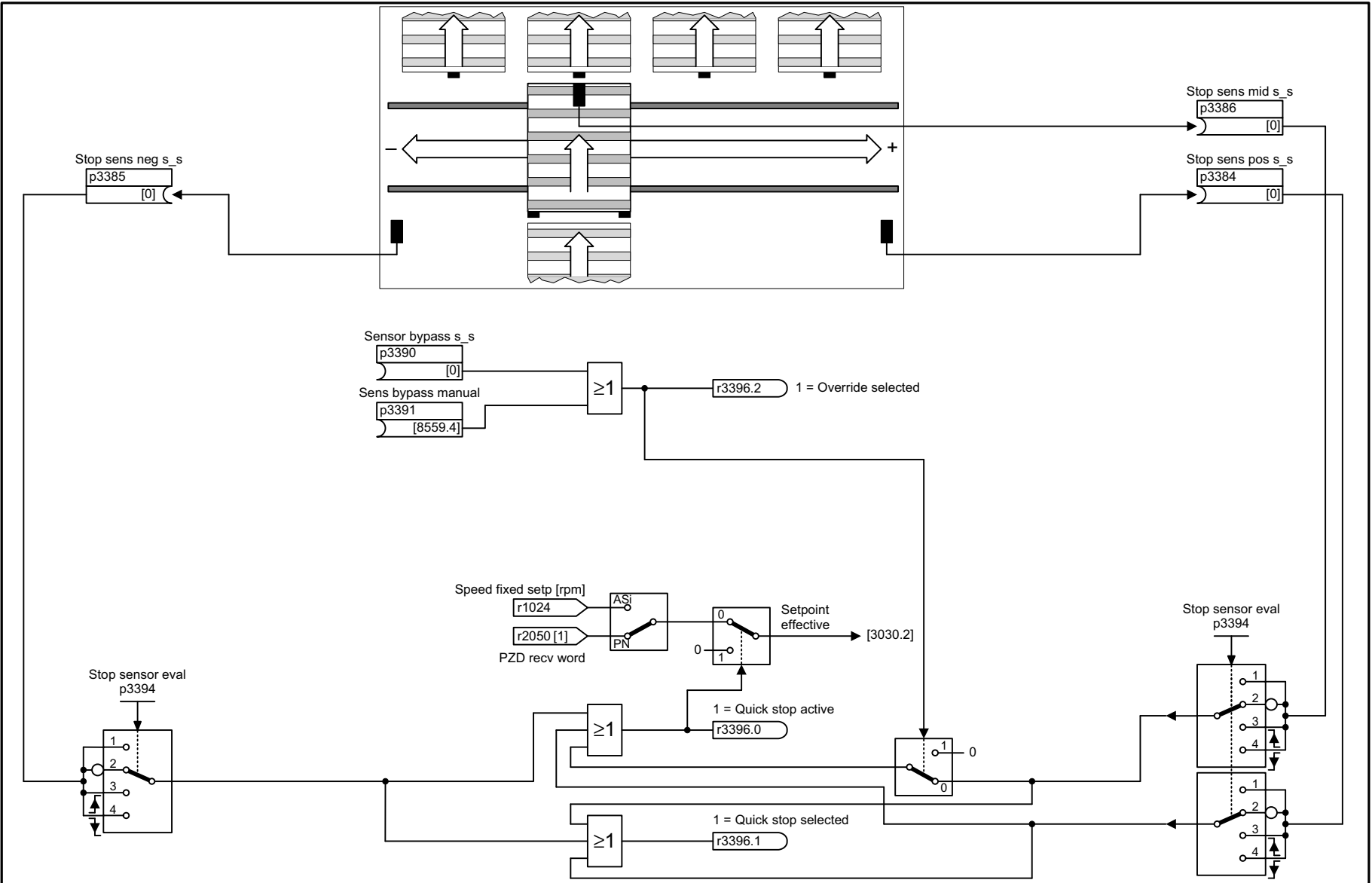

1	2	3	4	5	6	7	8
Conveying applications					fp_7050_97_08.vsd	Function diagram	
Travelling Trolley, 1 Speed (p3393 = 11)					20.07.2021 V4.7_13	G115D	
- 7050 -							

Fig. 3-118 7050 – Travelling Trolley, 1 Speed (p3393 = 11)

Fig. 3-119 7051 – Travelling Trolley, 2 Speeds (p3393 = 12)

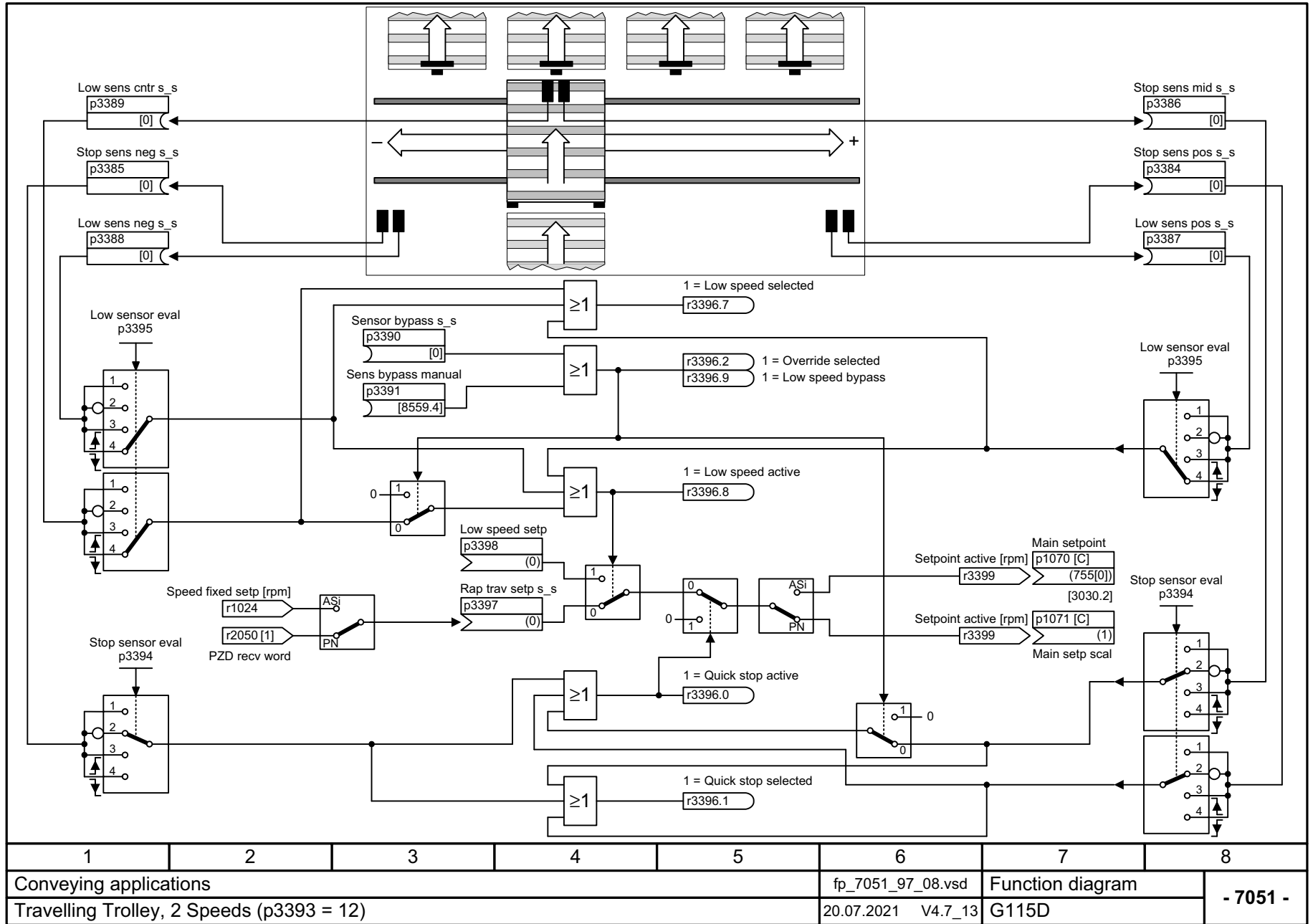

1	2	3	4	5	6	7	8
Conveying applications					fp_7051_97_08.vsd	Function diagram	
Travelling Trolley, 2 Speeds (p3393 = 12)					20.07.2021 V4.7_13	G115D	
- 7051 -							

3.16 Free function blocks

Function diagrams

7200 – Sampling times of the runtime groups	633
7210 – AND 0 ... 3	634
7212 – OR 0 ... 3	635
7214 – XOR 0 ... 3	636
7216 – NOT 0 ... 5	637
7220 – ADD 0 ... 2, SUB 0 ... 1	638
7222 – MUL 0 ... 1, DIV 0 ... 1	639
7224 – AVA 0 ... 1	640
7225 – NCM 0 ... 1	641
7226 – PLI 0 ... 1	642
7230 – MFP 0 ... 3, PCL 0 ... 1	643
7232 – PDE 0 ... 3	644
7233 – PDF 0 ... 3	645
7234 – PST 0 ... 1	646
7240 – RSR 0 ... 2, DFR 0 ... 2	647
7250 – BSW 0 ... 1, NSW 0 ... 1	648
7260 – LIM 0 ... 1	649
7262 – PT1 0 ... 1	650
7264 – INT 0, DIF 0	651
7270 – LVM 0 ... 1	652

	Run-time group						RTG sampling time [ms] r20001[0..9]
	1	2	3	4	5	6	
	r20001[1] = 8 ms	r20001[2] = 16 ms	r20001[3] = 32 ms	r20001[4] = 64 ms	r20001[5] = 128 ms	r20001[6] = 256 ms	
Logic function blocks AND, OR, XOR, NOT	X	X	X	X	X	X	
Arithmetic function blocks ADD, SUB, MUL, DIV, AVA, NCM, PLI	-	-	-	-	X	X	
Time function blocks MFP, PCL, PDE, PDF, PST	-	-	-	-	X	X	
Memory function blocks RSR, DSR	X	X	X	X	X	X	
Switch function block NSW	-	-	-	-	X	X	
Switch function block BSW	X	X	X	X	X	X	
Control function blocks LIM, PT1, INT, DIF	-	-	-	-	X	X	
Complex function blocks LVM	-	-	-	-	X	X	

1	2	3	4	5	6	7	8
Free Function Blocks					fp_7200_97_61.vsd	Function diagram	
Sampling times of the runtime groups					20.07.2021 V4.7_13	G115D	
							- 7200 -

Fig. 3-120 7200 – Sampling times of the runtime groups

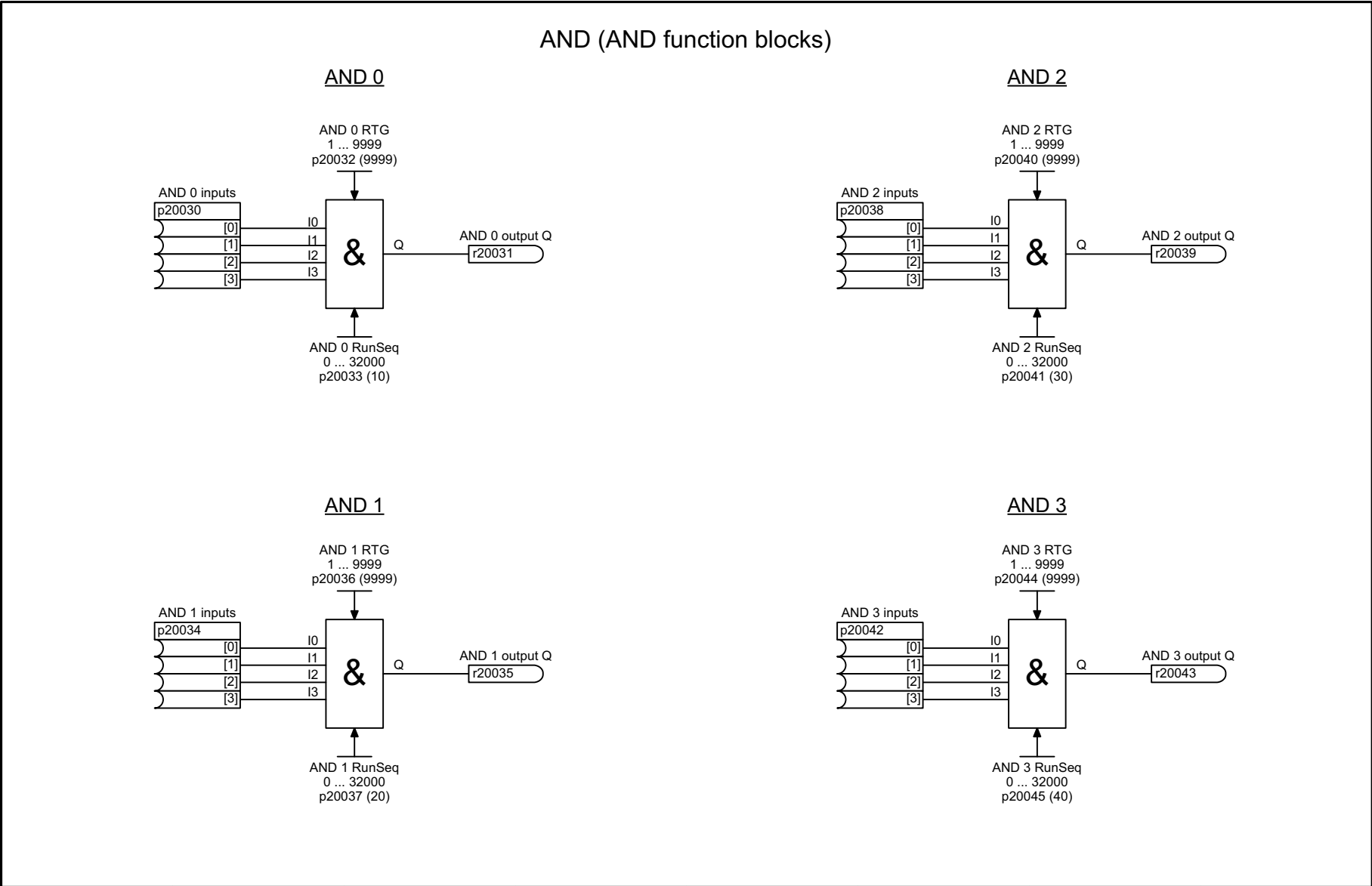

1	2	3	4	5	6	7	8
Free function blocks - Logic function blocks					fp_7210_97_61.vsd	Function diagram	
AND 0 ... 3					20.07.2021 V4.7_13	G115D	

Fig. 3-121 7210 - AND 0 ... 3

OR (OR function blocks)

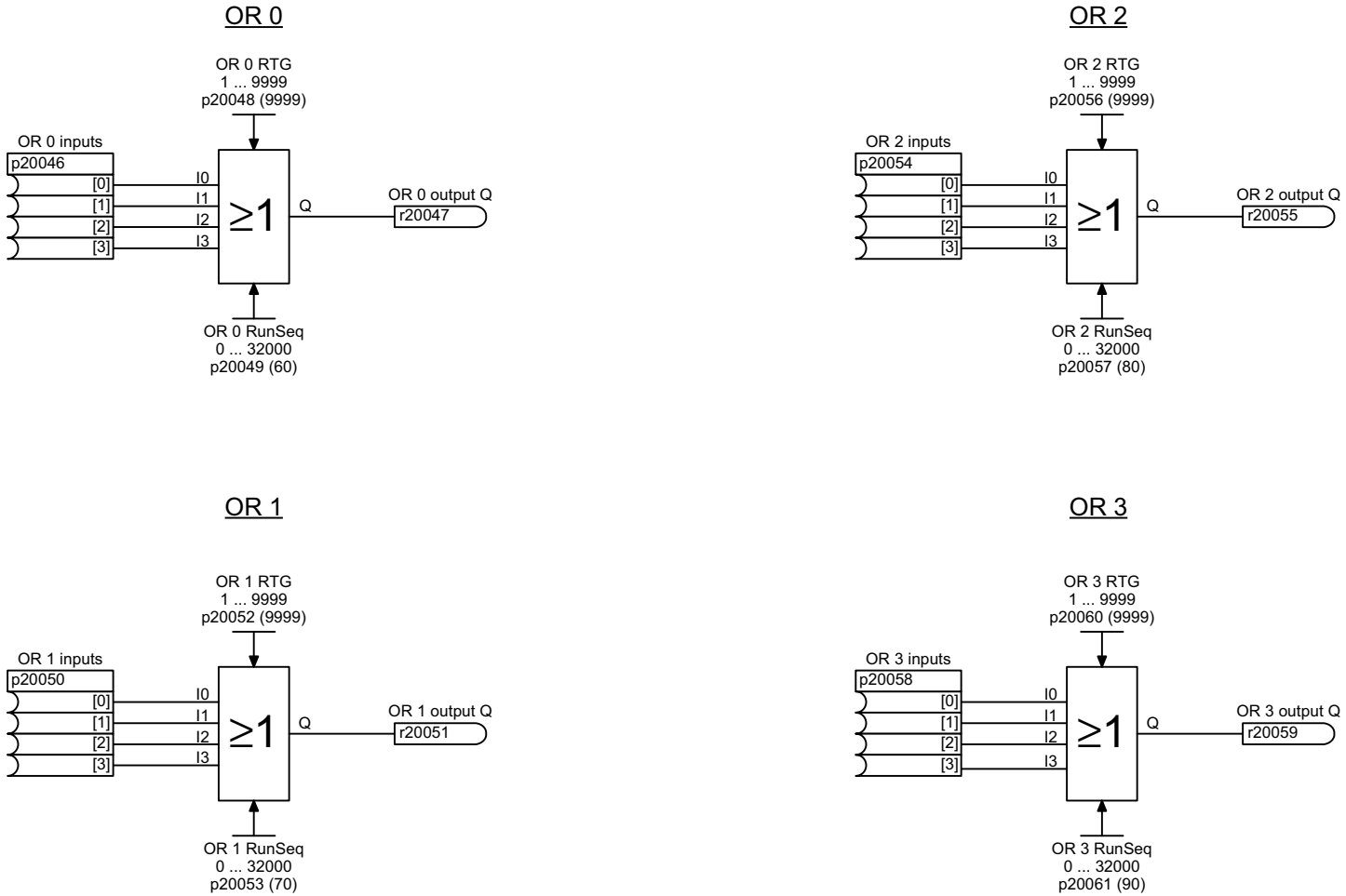

1	2	3	4	5	6	7	8
Free function blocks - Logic function blocks					fp_7212_97_61.vsd	Function diagram	
OR 0 ... 3					20.07.2021 V4.7_13	G115D	
							- 7212 -

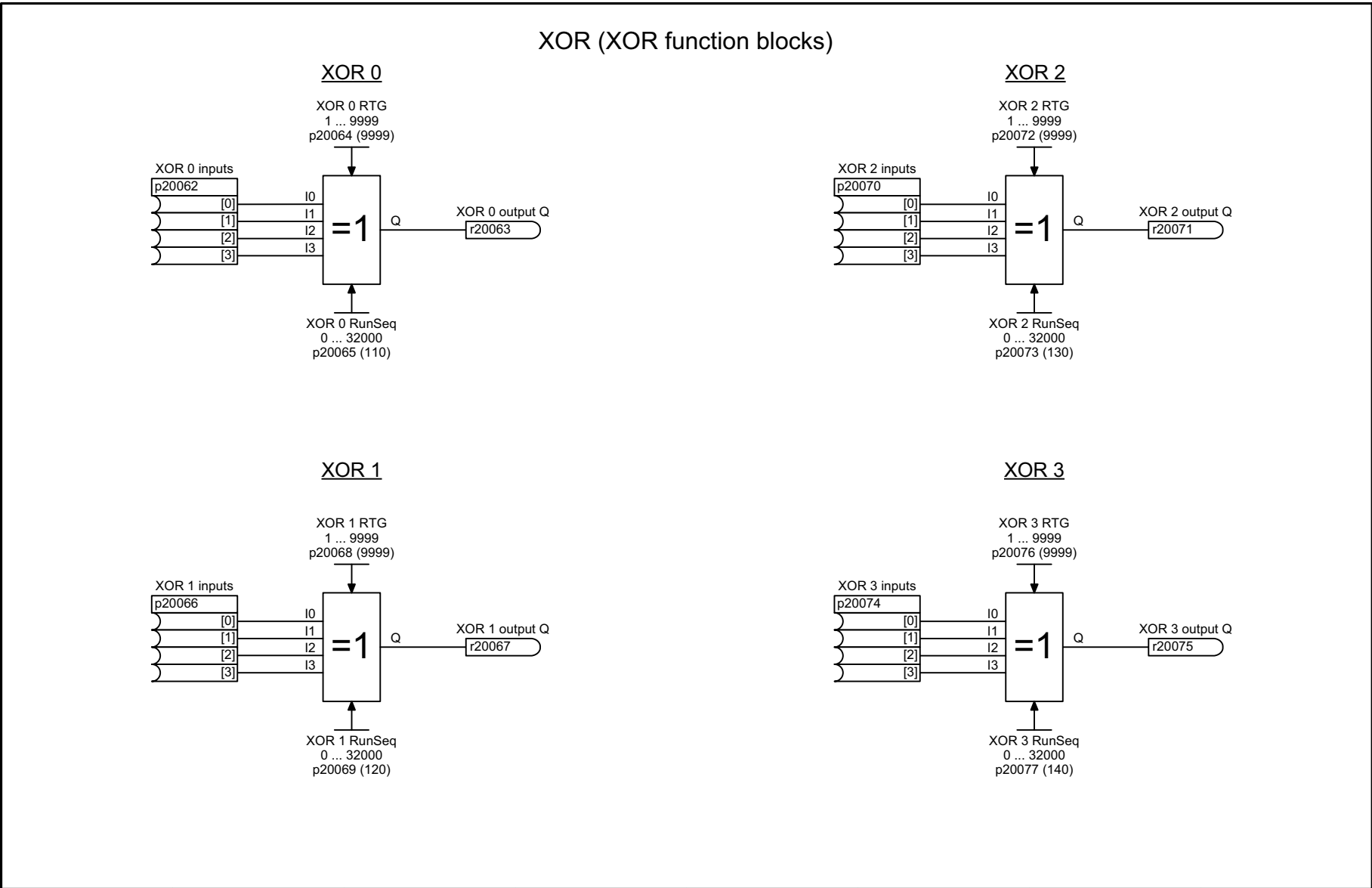

1	2	3	4	5	6	7	8
Free function blocks - Logic function blocks					fp_7214_97_61.vsd	Function diagram	
XOR 0 ... 3					20.07.2021 V4.7_13	G115D	
							- 7214 -

Fig. 3-123 7214 – XOR 0 ... 3

Fig. 3-124 7216 – NOT 0 ... 5

NOT (inverter)

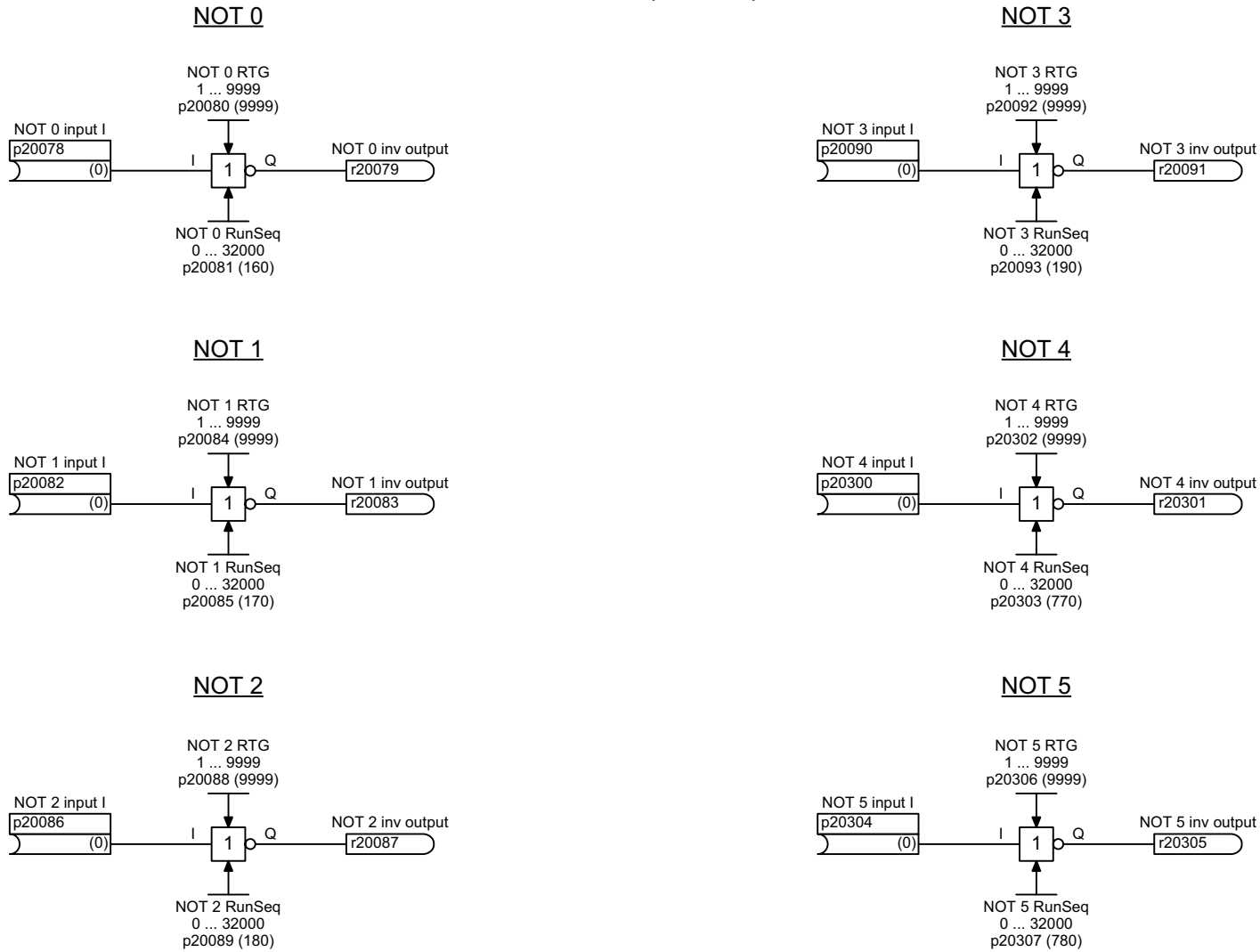

1	2	3	4	5	6	7	8
Free function blocks - Logic function blocks					fp_7216_97_61.vsd	Function diagram	
NOT 0 ... 5					20.07.2021 V4.7_13	G115D	
							- 7216 -

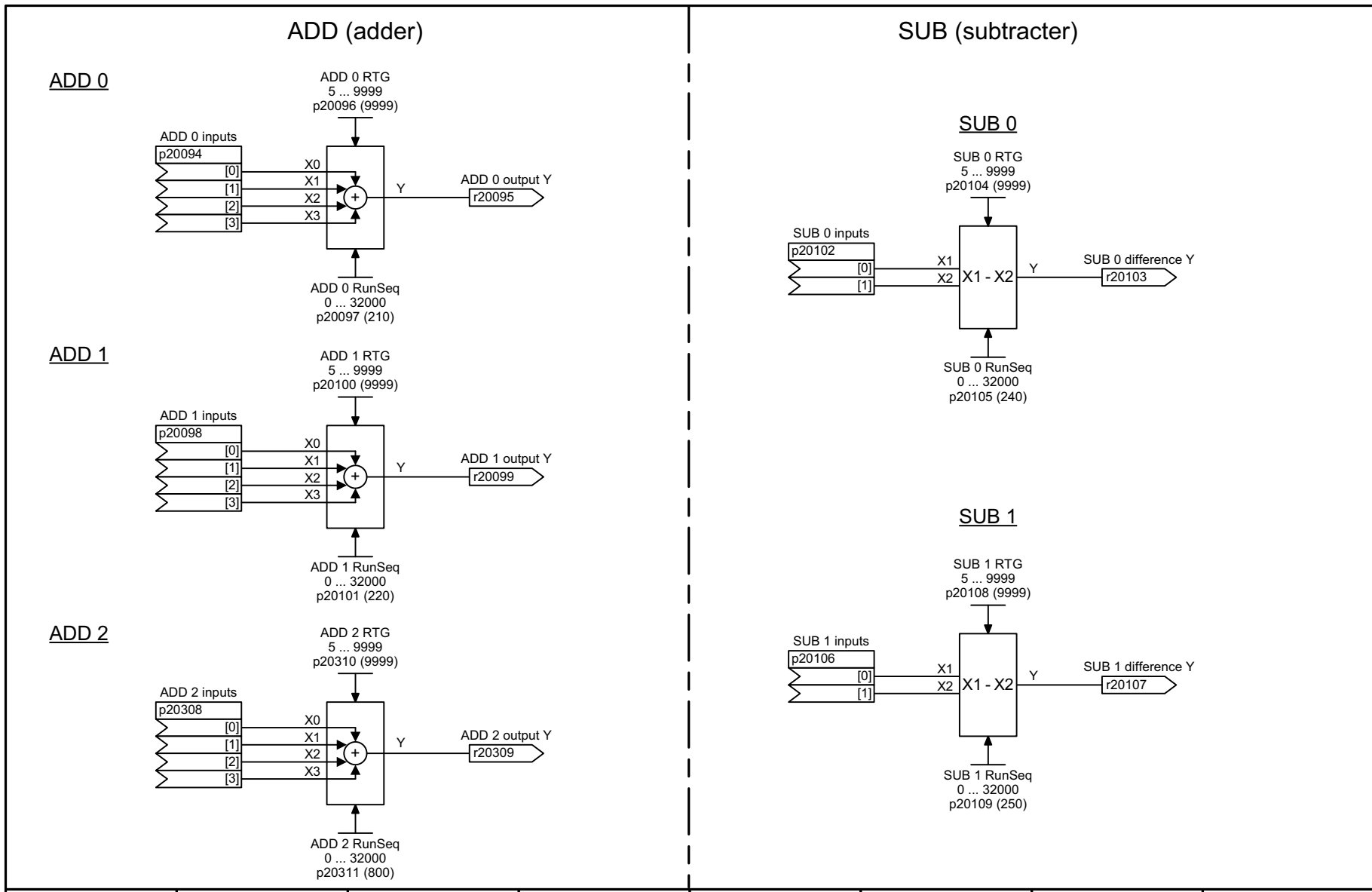

1	2	3	4	5	6	7	8
Free function blocks - Arithmetic function blocks					fp_7220_97_61.vsd	Function diagram	
ADD 0 ... 2, SUB 0 ... 1					20.07.2021 V4.7_13	G115D	

Fig. 3-125 7220 – ADD 0 ... 2, SUB 0 ... 1

Fig. 3-126 7222 – MUL 0 ... 1, DIV 0 ... 1

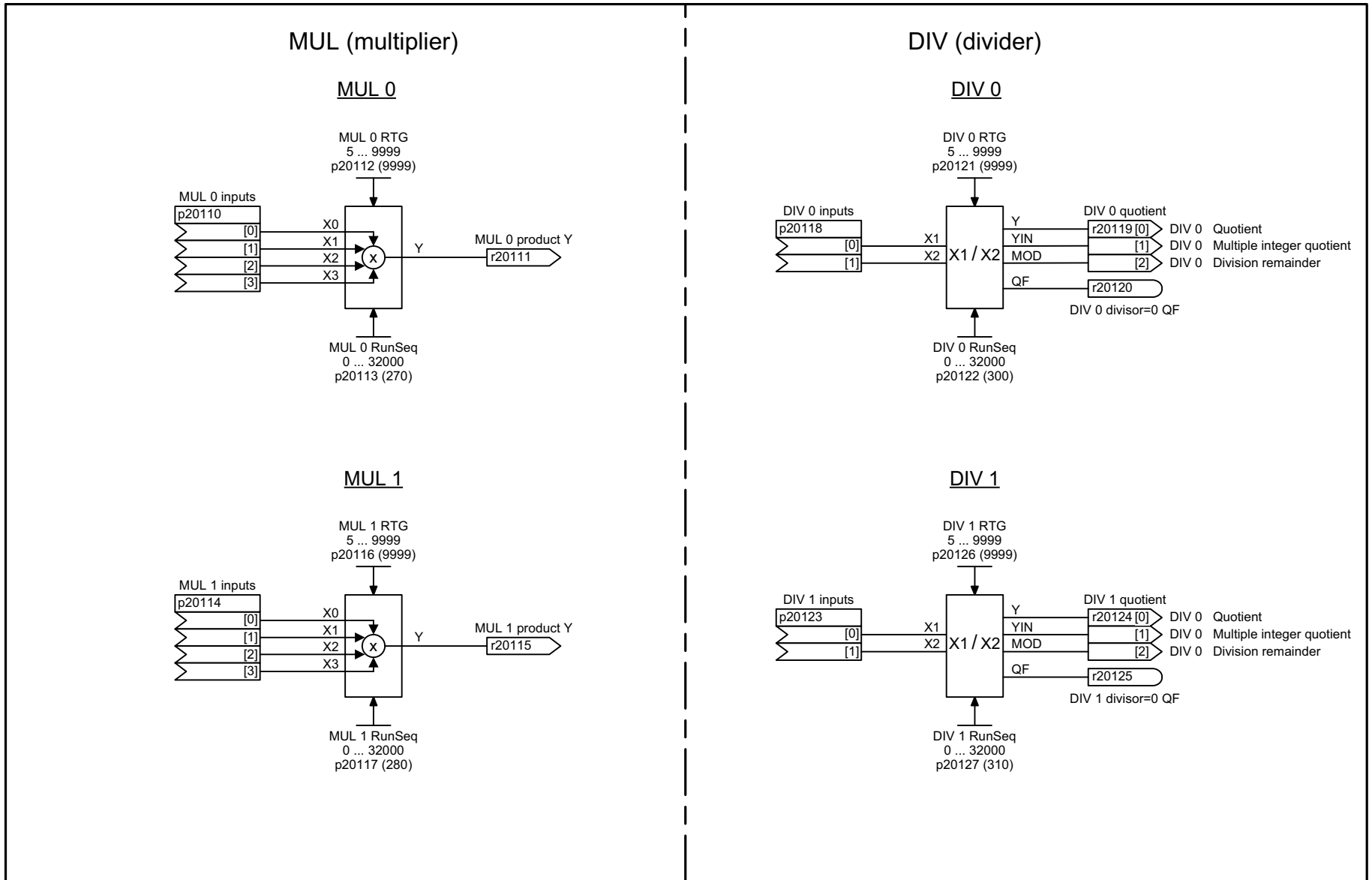

1	2	3	4	5	6	7	8
Free function blocks - Arithmetic function blocks					fp_7222_97_61.vsd	Function diagram	
MUL 0 ... 1, DIV 0 ... 1					20.07.2021 V4.7_13	G115D	
							- 7222 -

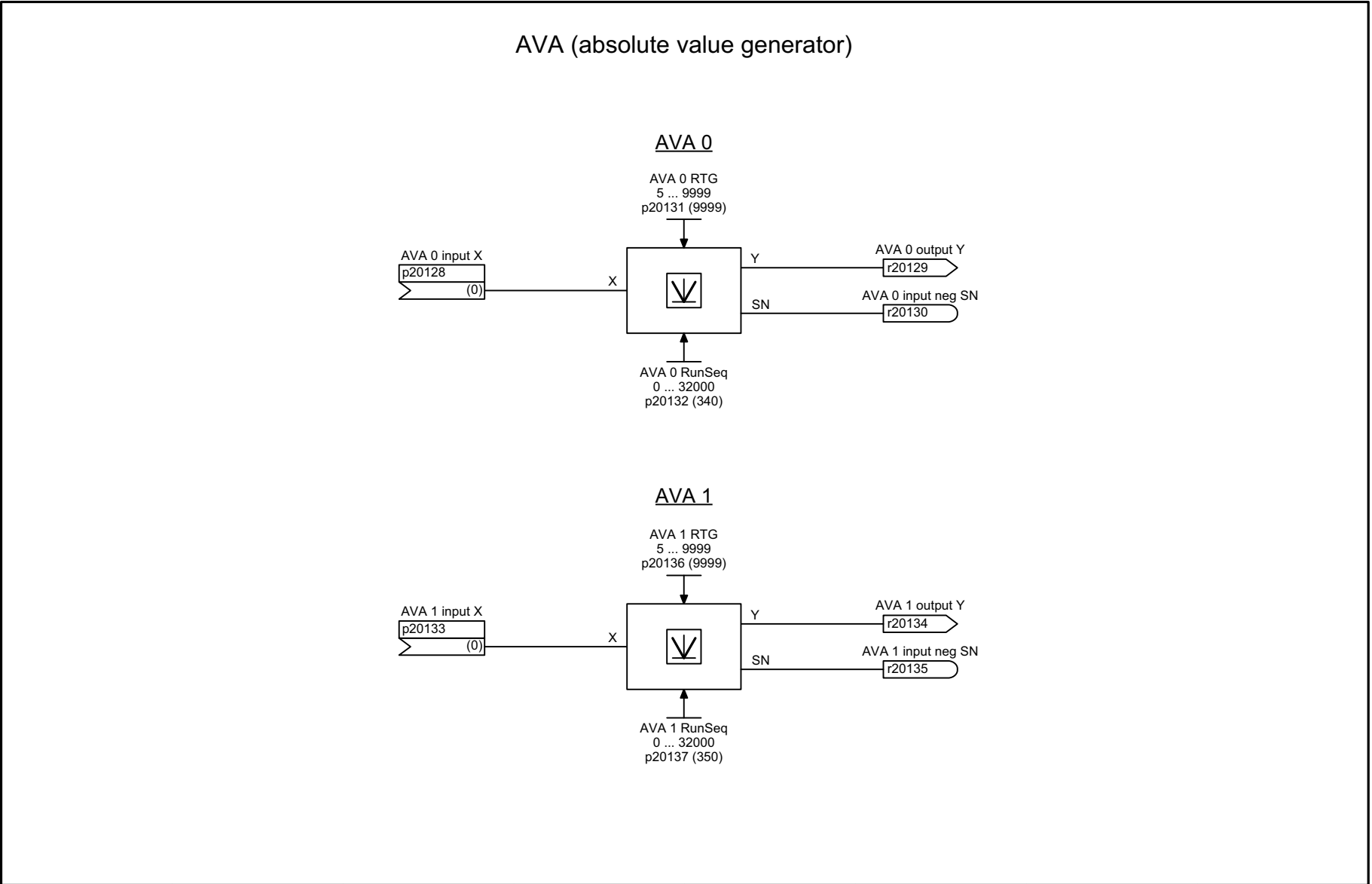
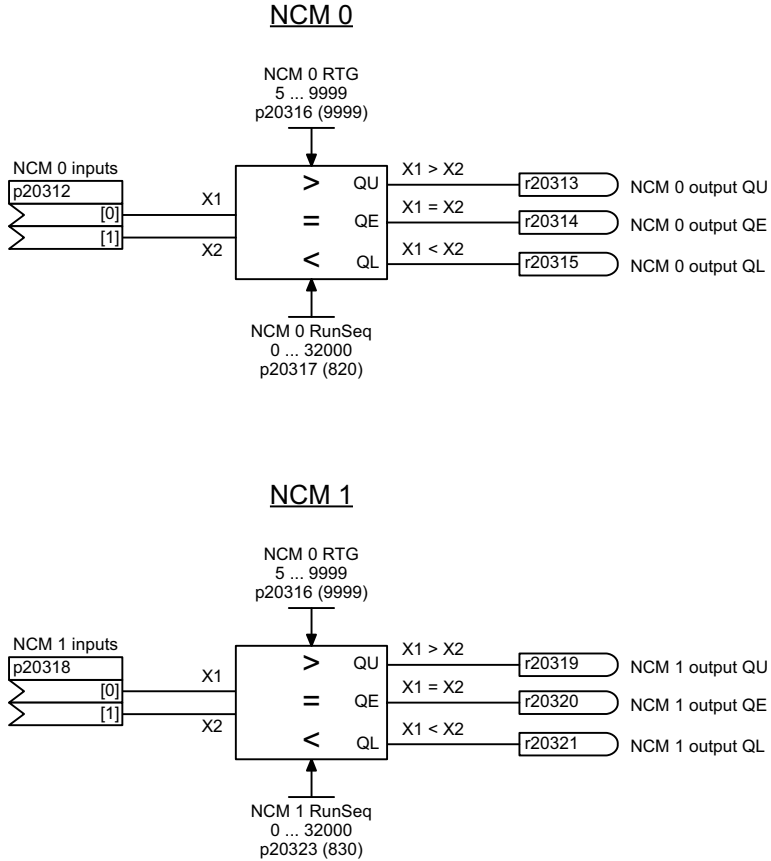

Fig. 3-127 7224 – AVA 0 ... 1

1	2	3	4	5	6	7	8
Free function blocks - Arithmetic function blocks					fp_7224_97_61.vsd	Function diagram	
AVA 0 ... 1					20.07.2021 V4.7_13	G115D	
							- 7224 -

NCM (numeric comparator)



1	2	3	4	5	6	7	8
Free function blocks - Arithmetic function blocks					fp_7225_97_61.vsd	Function diagram	
NCM 0 ... 1					20.07.2021 V4.7_13	G115D	
							- 7225 -

Fig. 3-128 7225 – NCM 0 ... 1

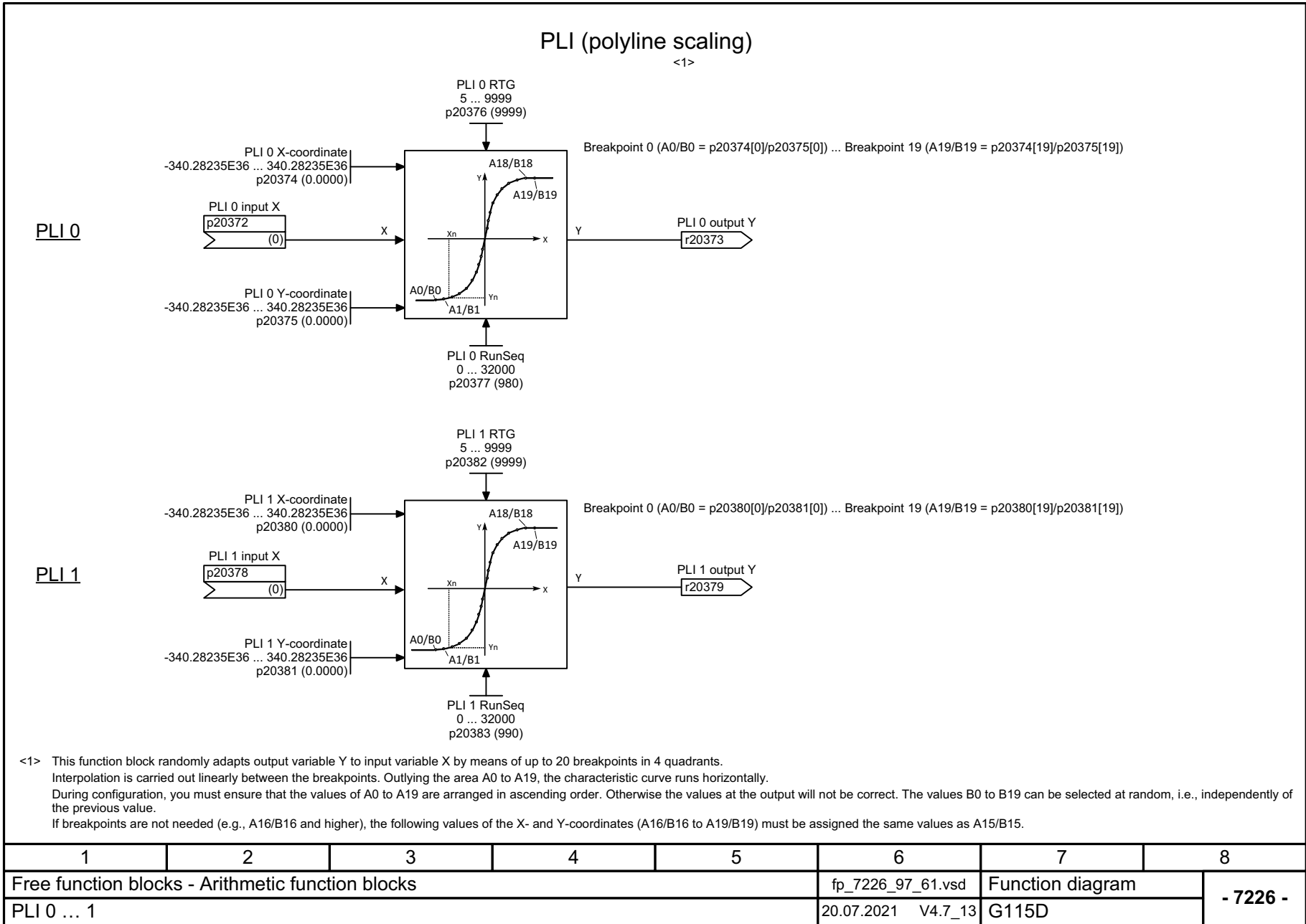
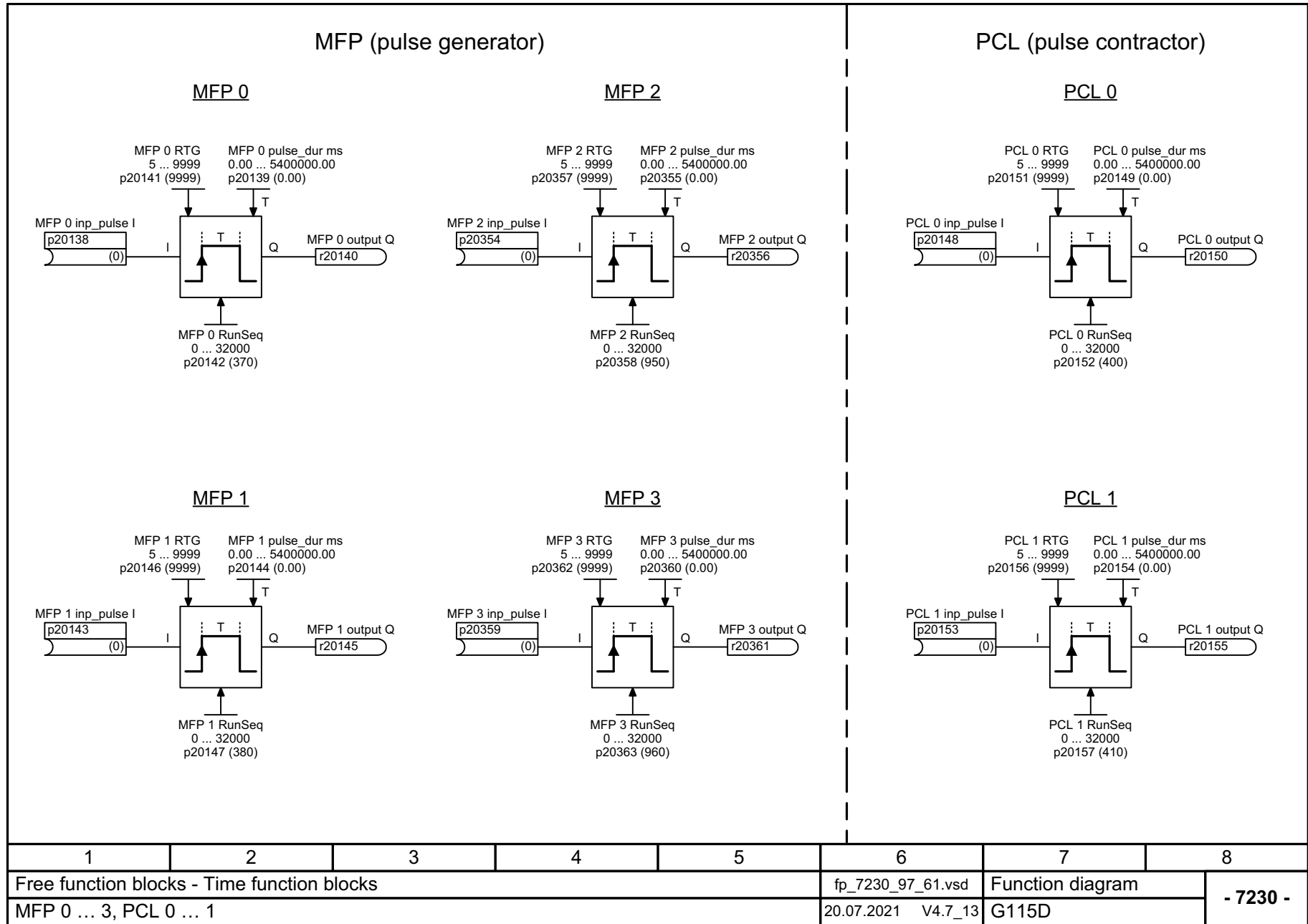
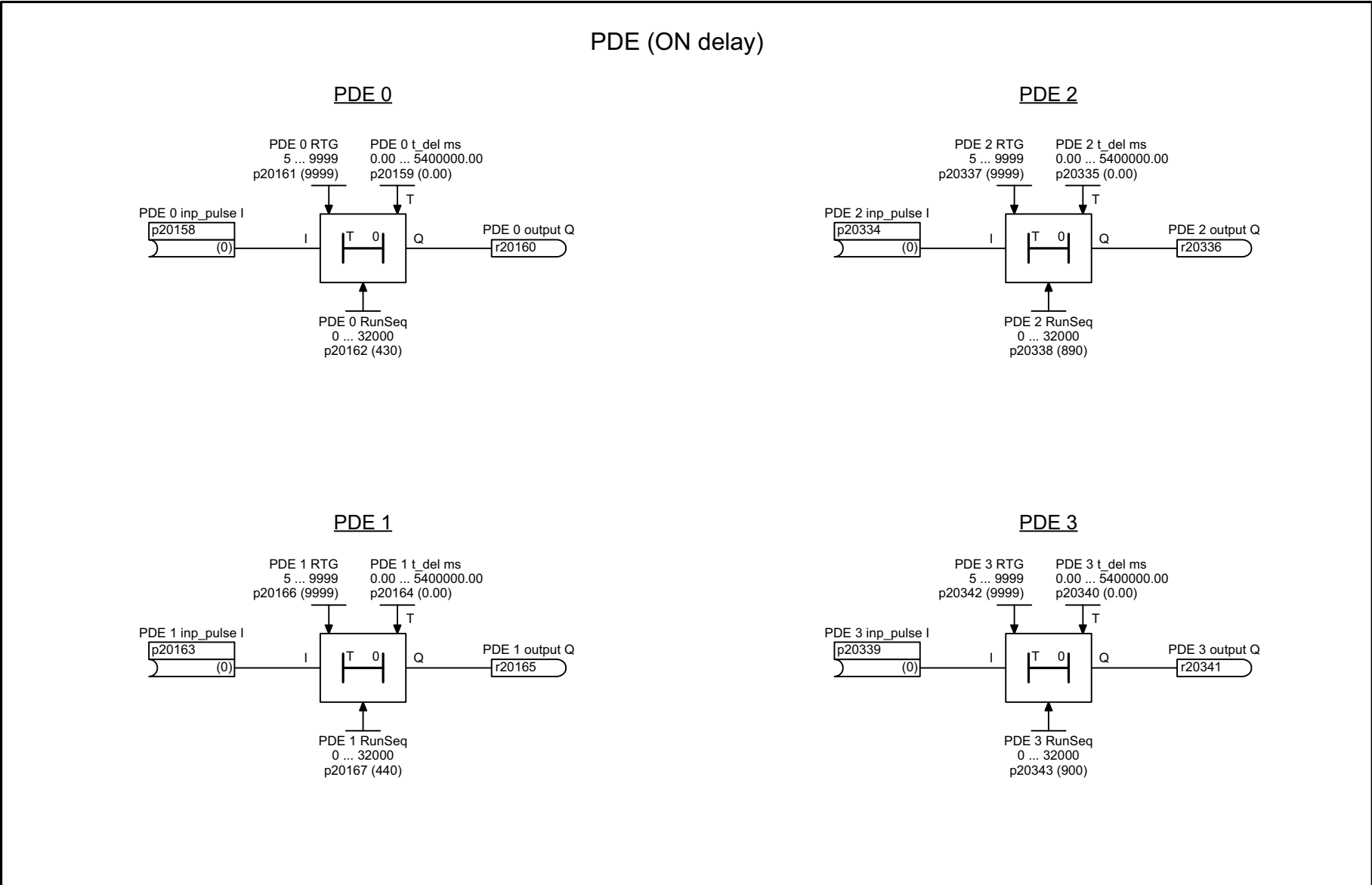

Fig. 3-129 7226 – PLI 0 ... 1

Fig. 3-130 7230 – MFP 0 ... 3, PCL 0 ... 1





1	2	3	4	5	6	7	8
Free function blocks - Time function blocks					fp_7232_97_61.vsd	Function diagram	
PDE 0 ... 3					20.07.2021 V4.7_13	G115D	
							- 7232 -

Fig. 3-131 7232 - PDE 0 ... 3

Fig. 3-132 7233 – PDF 0 ... 3

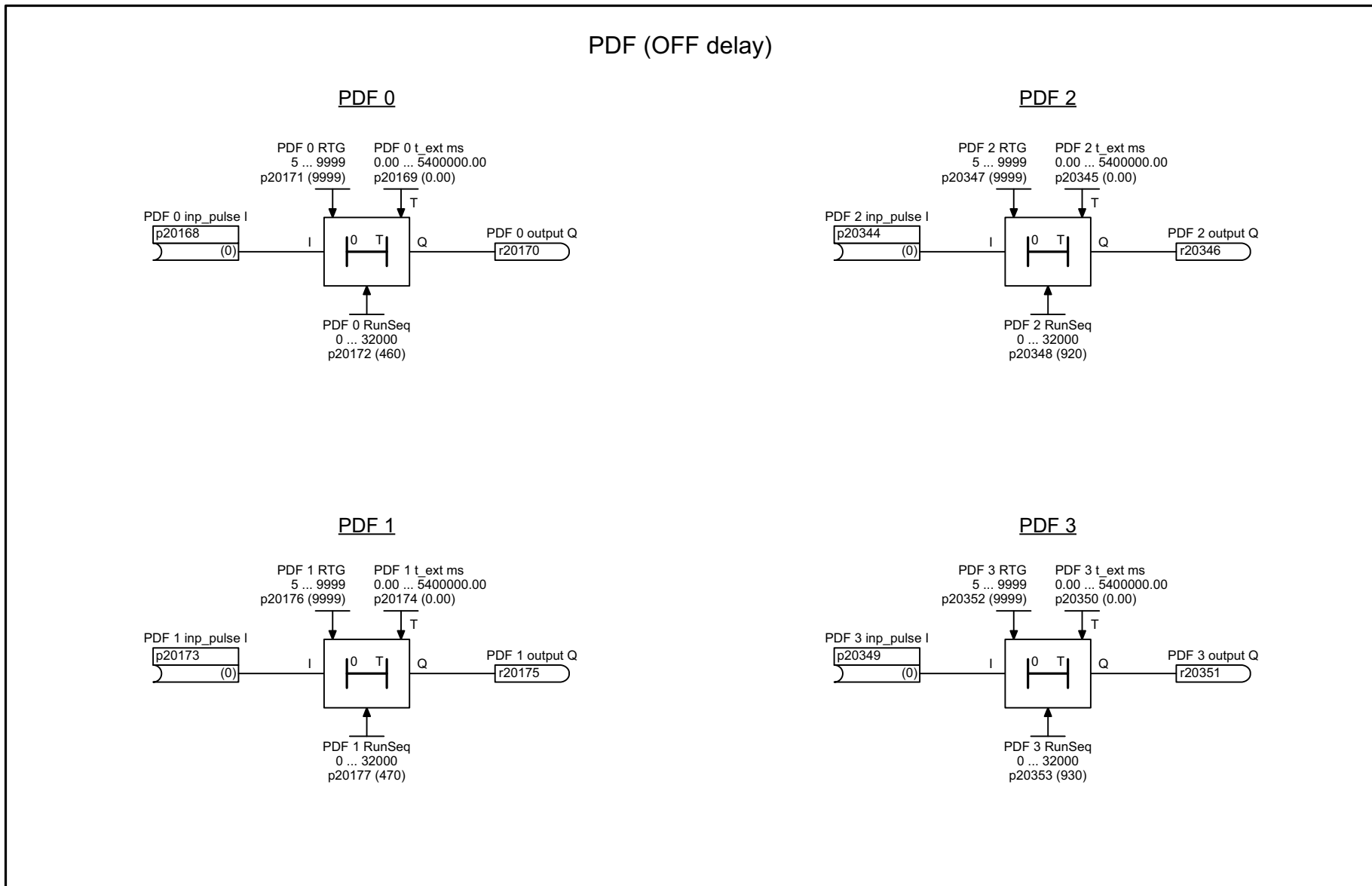

1	2	3	4	5	6	7	8
Free function blocks - Time function blocks					fp_7233_97_61.vsd	Function diagram	
PDF 0 ... 3					20.07.2021 V4.7_13	G115D	
							- 7233 -

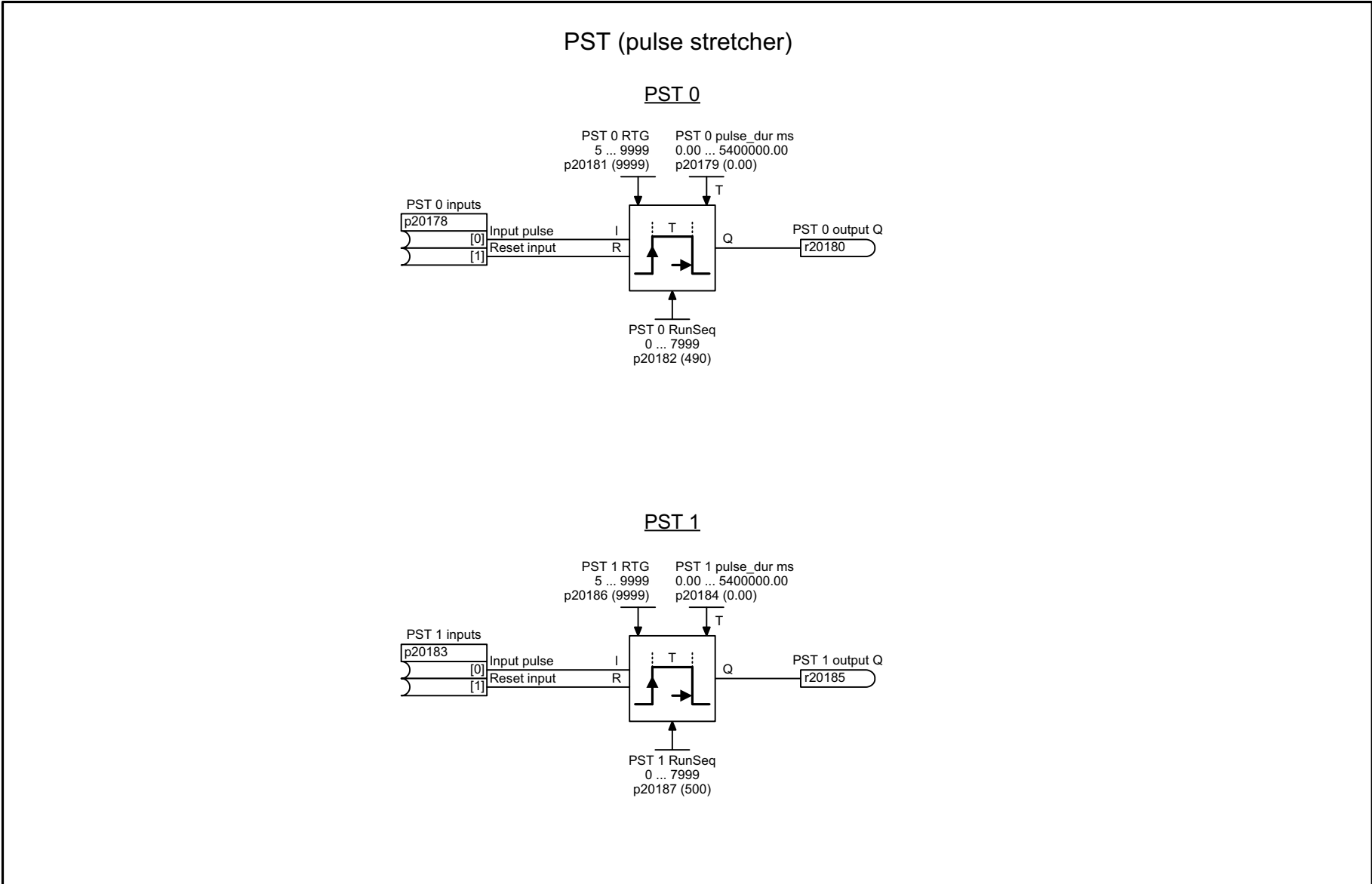
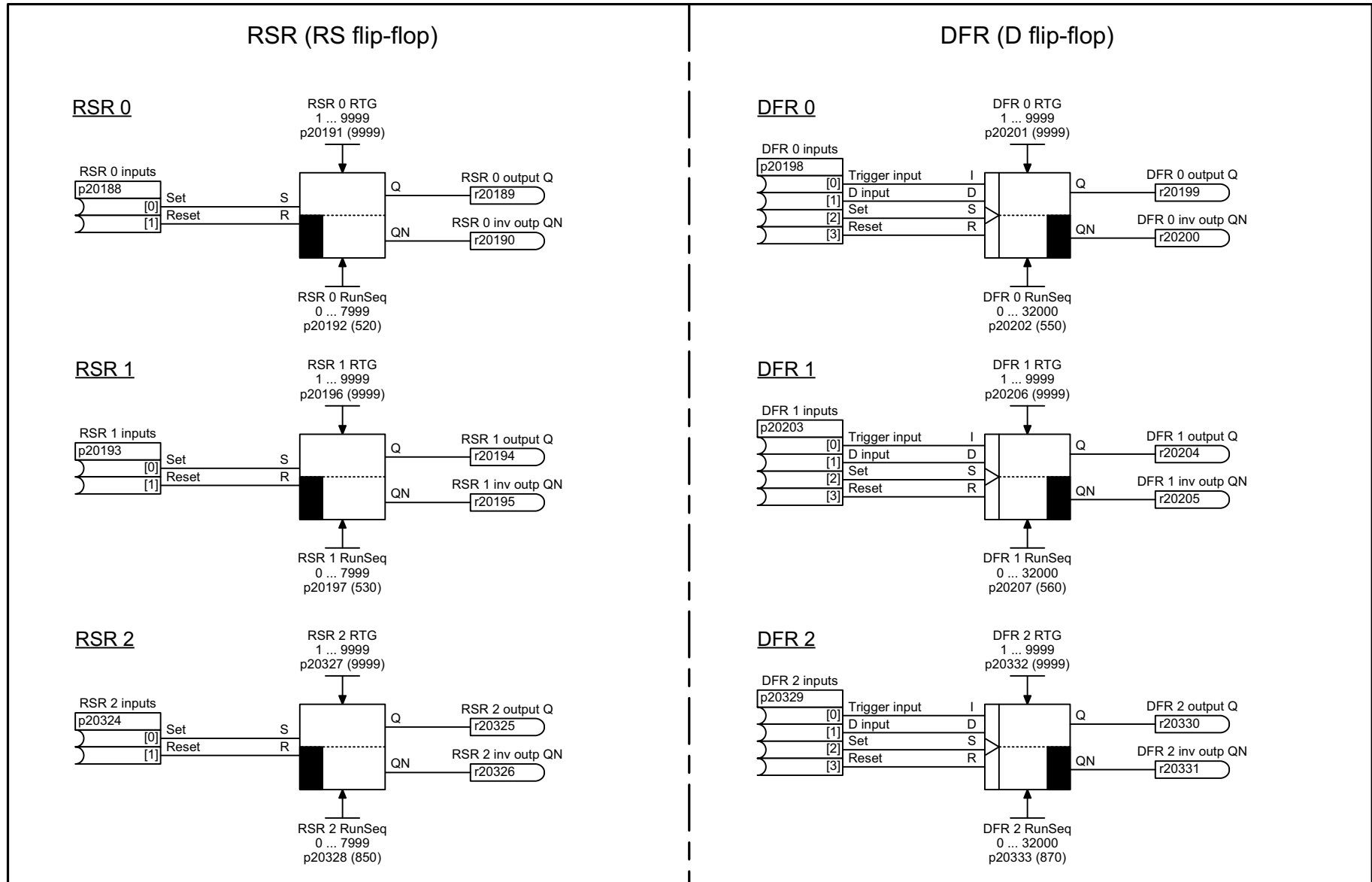

Fig. 3-133 7234 – PST 0 ... 1

1	2	3	4	5	6	7	8
Free function blocks - Time function blocks					fp_7234_97_61.vsd	Function diagram	
PST 0 ... 1					20.07.2021 V4.7_13	G115D	
							- 7234 -

Fig. 3-134 7240 – RSR 0 ... 2, DFR 0 ... 2



1	2	3	4	5	6	7	8
Free function blocks - Flipflop function blocks					fp_7240_97_61.vsd	Function diagram	
RSR 0 ... 2, DFR 0 ... 2					20.07.2021 V4.7_13	G115D	

- 7240 -

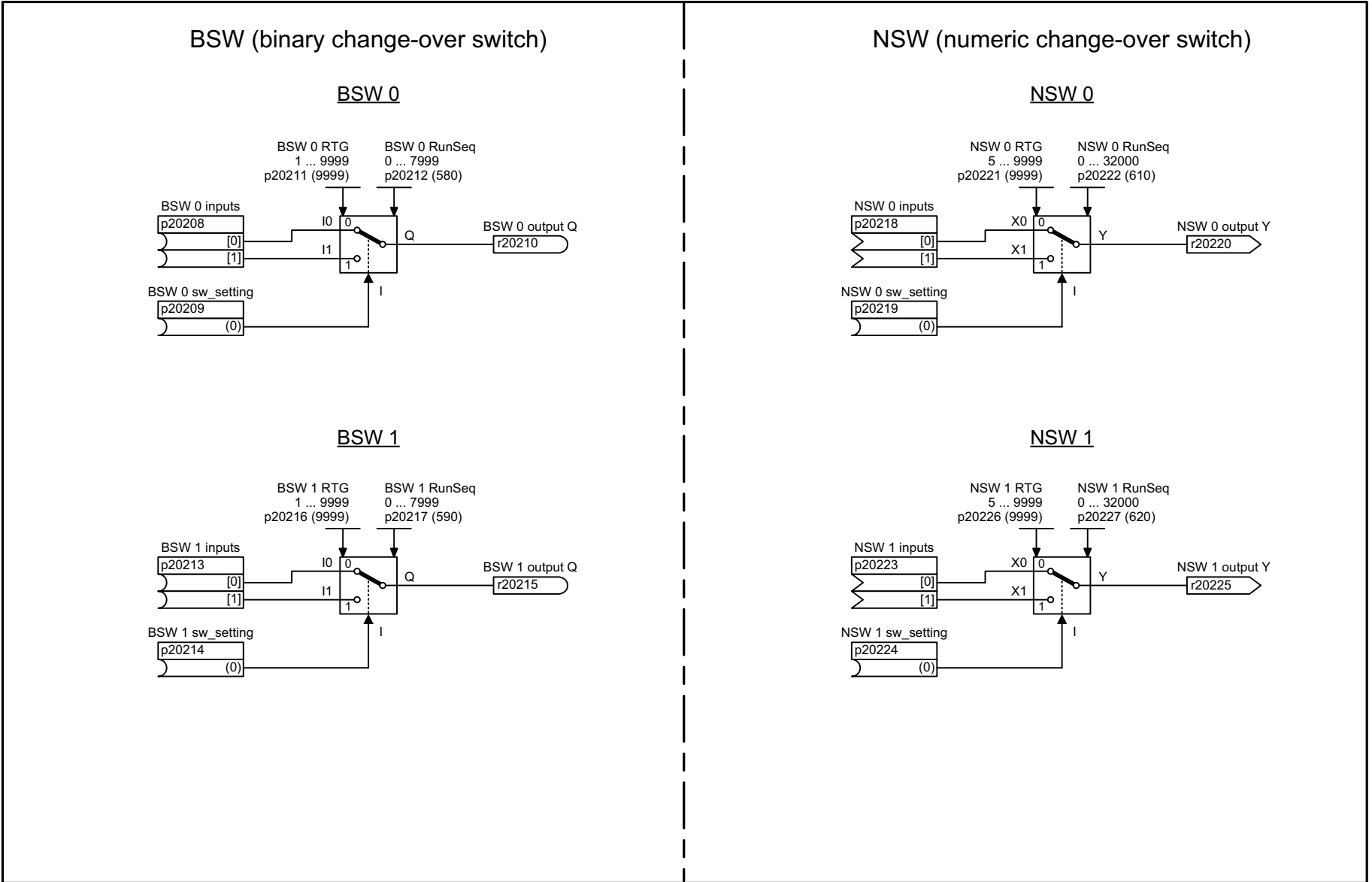

1	2	3	4	5	6	7	8
Free function blocks - Switch function blocks					fp_7250_97_61.vsd	Function diagram	
BSW 0 ... 1, NSW 0 ... 1					20.07.2021 V4.7_13	G115D	
							- 7250 -

Fig. 3-135 7250 – BSW 0 ... 1, NSW 0 ... 1

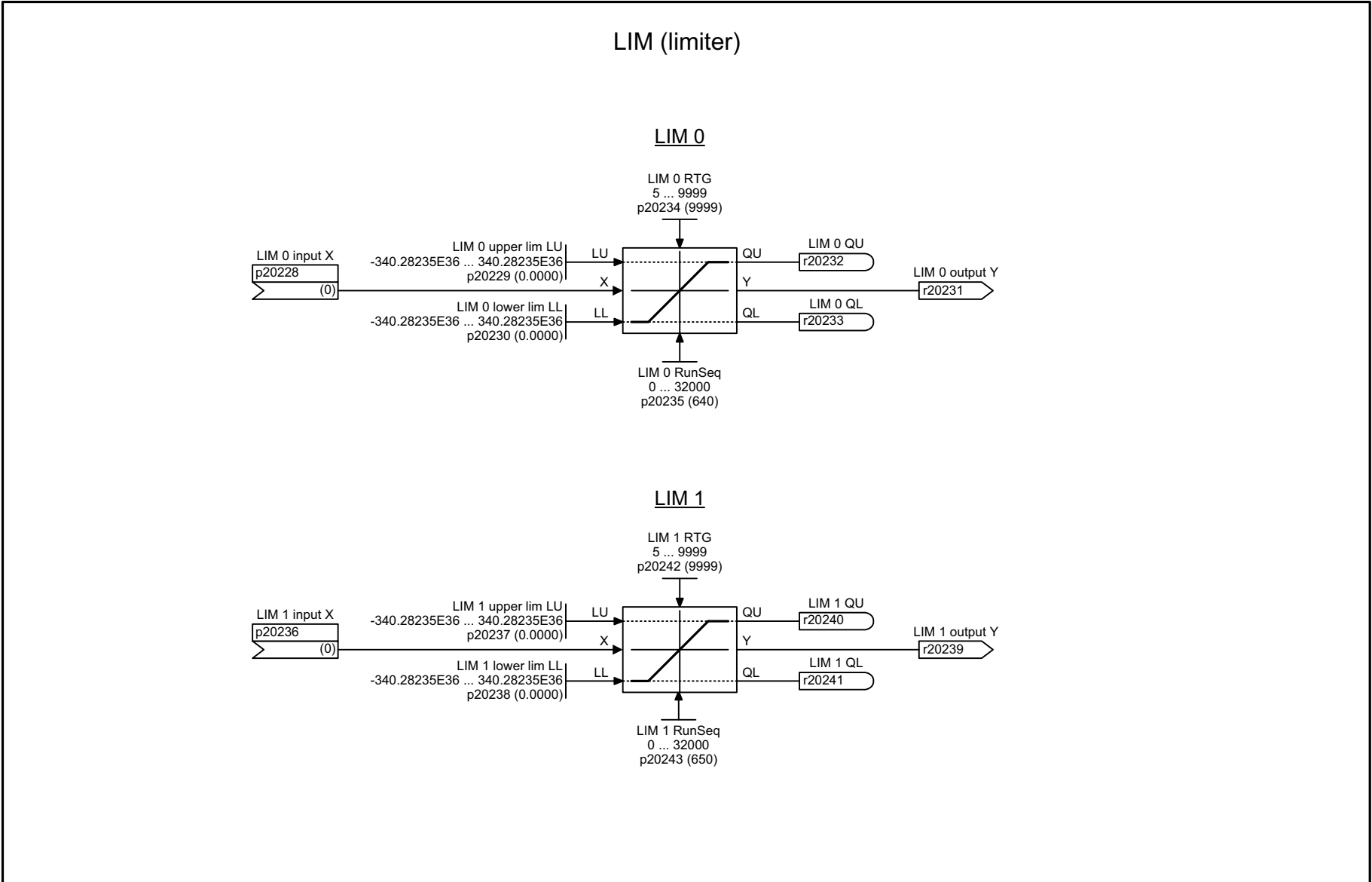

1	2	3	4	5	6	7	8
Free function blocks - Control function blocks					fp_7260_97_61.vsd	Function diagram	
LIM 0 ... 1					20.07.2021 V4.7_13	G115D	
- 7260 -							

Fig. 3-136 7260 – LIM 0 ... 1

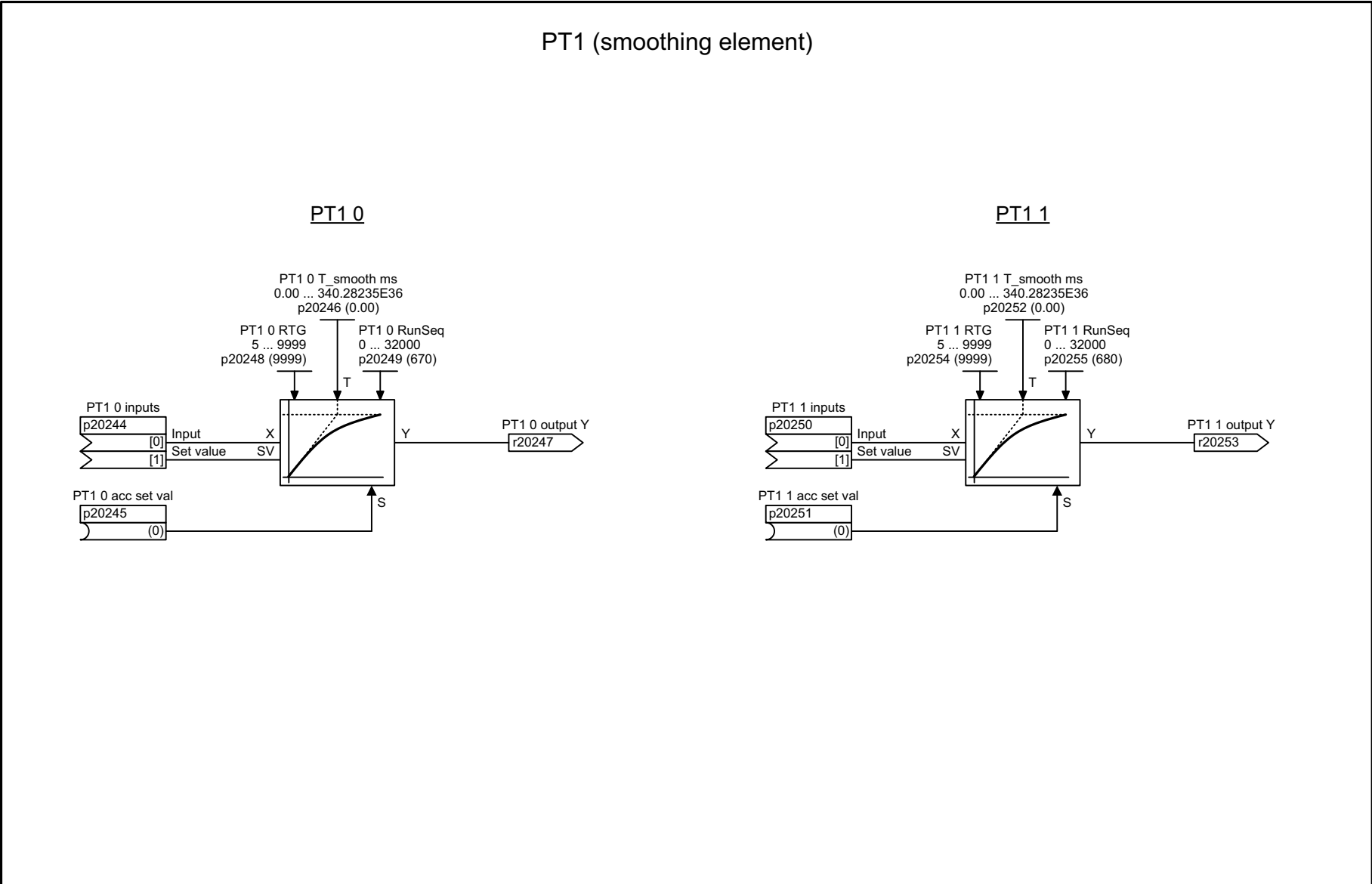

1	2	3	4	5	6	7	8
Free function blocks - Control function blocks					fp_7262_97_61.vsd	Function diagram	
PT1 0 ... 1					20.07.2021 V4.7_13	G115D	
							- 7262 -

Fig. 3-137 7262 - PT1 0 ... 1

Fig. 3-138 7264 – INT 0, DIF 0

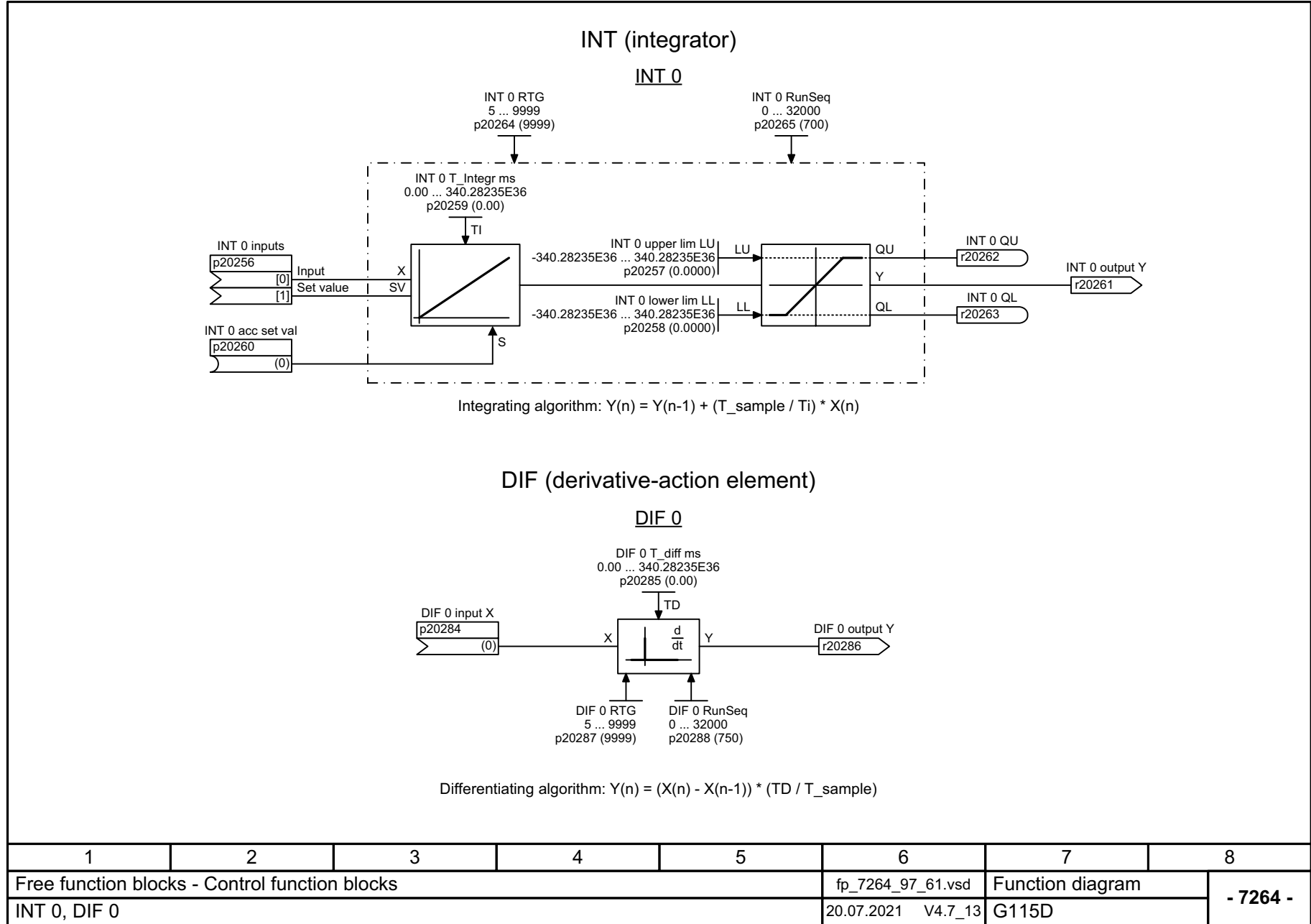

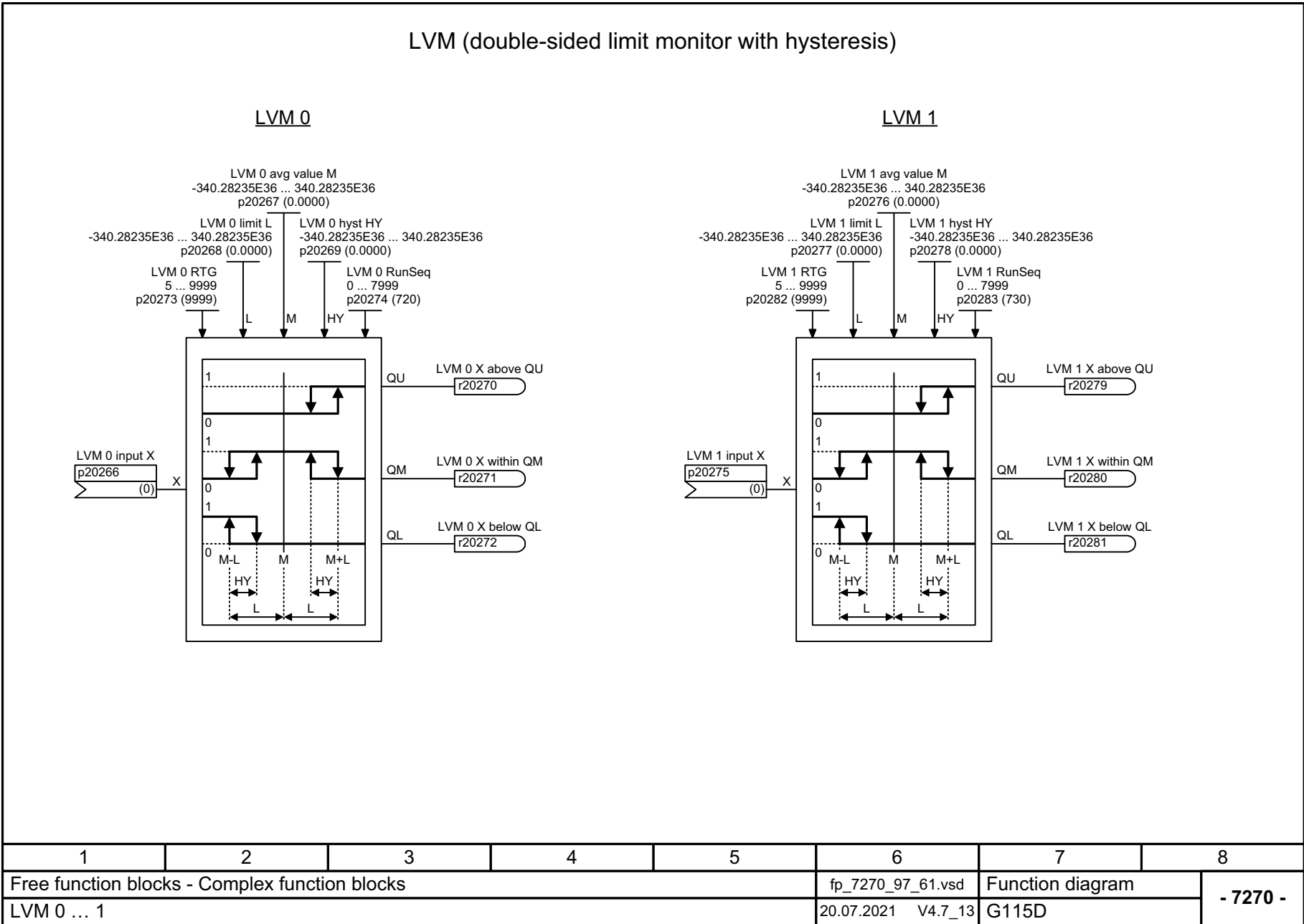

Fig. 3-139 7270 - LVM 0 ... 1

3.17 Technology controller

Function diagrams

7950 – Fixed values, binary selection (p2216 = 2)	654
7951 – Fixed values, direct selection (p2216 = 1)	655
7954 – Motorized potentiometer	656
7958 – Closed-loop control	657

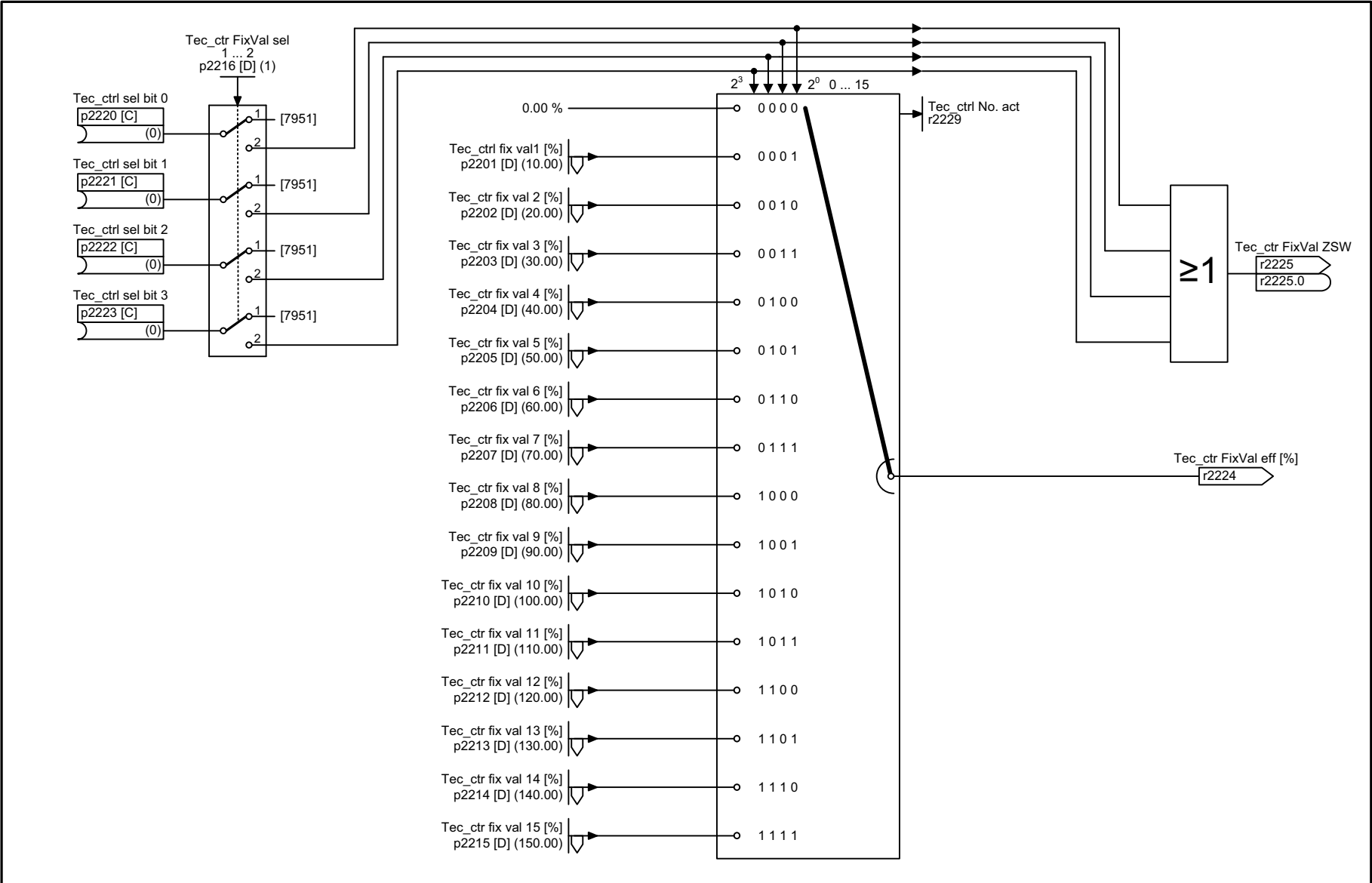
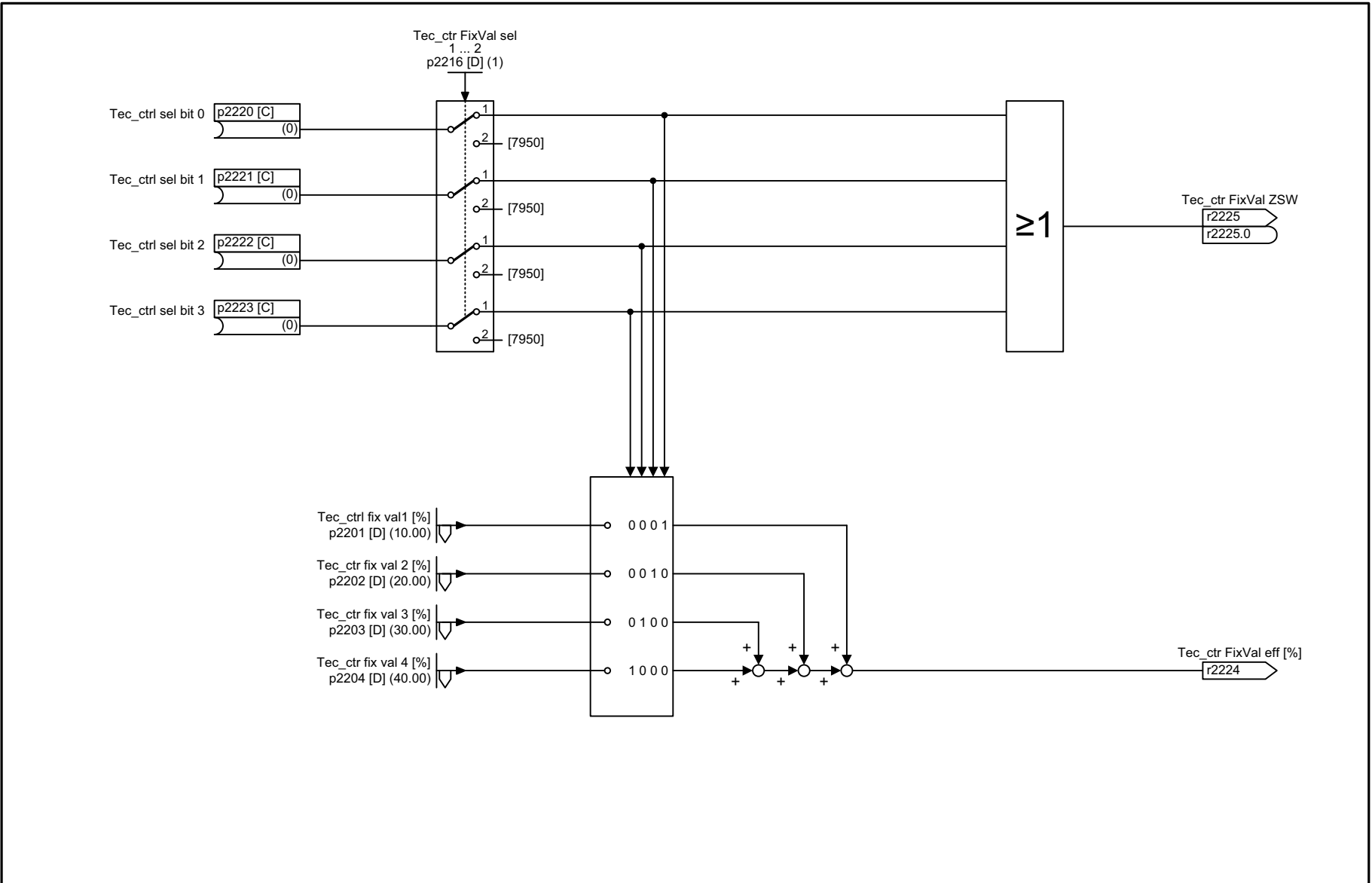

Fig. 3-140 7950 – Fixed values, binary selection (p2216 = 2)

1	2	3	4	5	6	7	8
Technology controller					fp_7950_97_51.vsd	Function diagram	
Fixed value selection binary (p2216 = 2)					20.07.2021 V4.7_13	G115D	
							- 7950 -



1	2	3	4	5	6	7	8
Technology controller					fp_7951_97_51.vsd	Function diagram	
Fixed value selection direct (p2216 = 1)					20.07.2021 V4.7_13	G115D	
							- 7951 -

Fig. 3-141 7951 – Fixed values, direct selection (p2216 = 1)

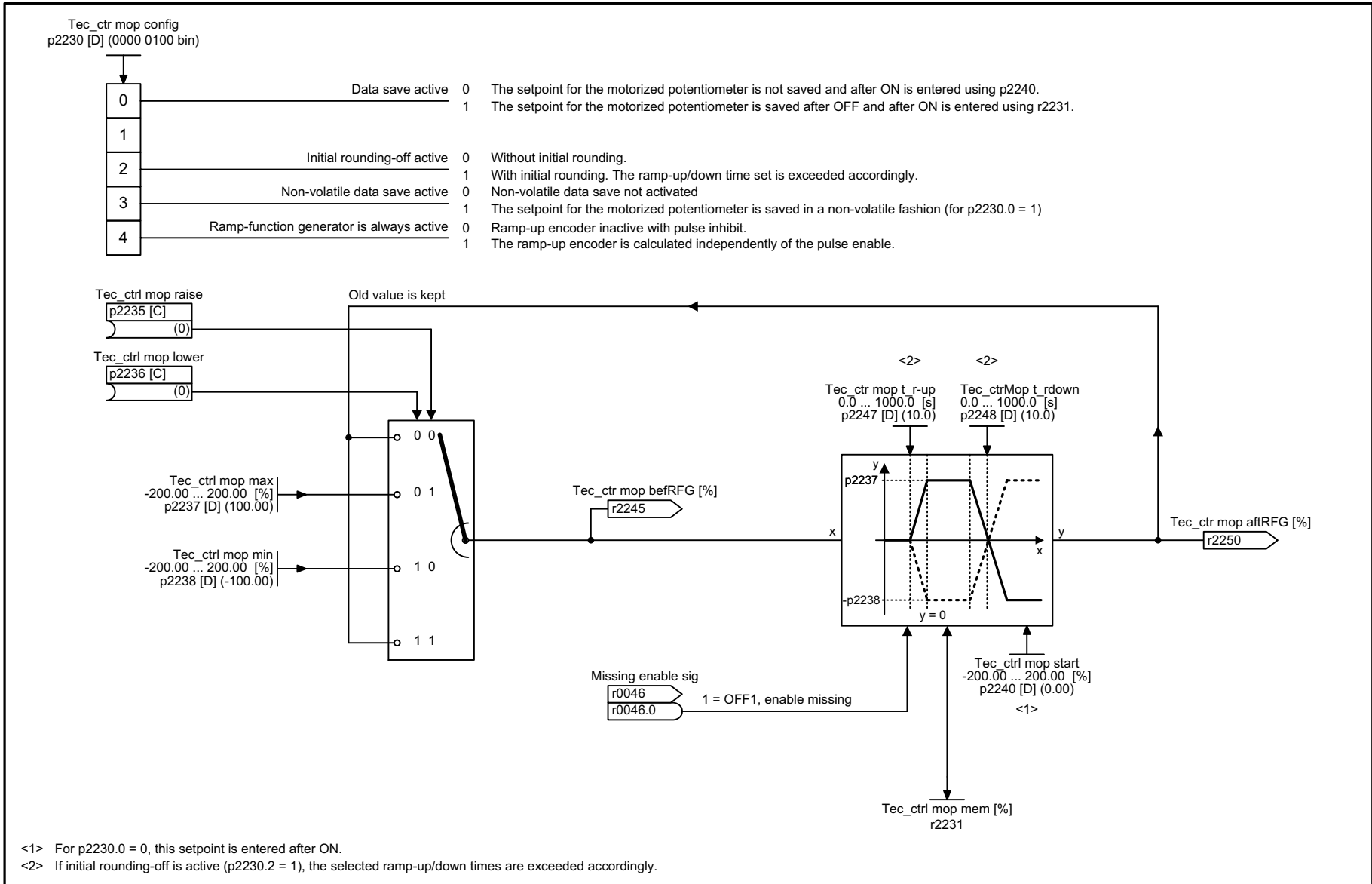

<1> For p2230.0 = 0, this setpoint is entered after ON.
<2> If initial rounding-off is active (p2230.2 = 1), the selected ramp-up/down times are exceeded accordingly.

1	2	3	4	5	6	7	8
Technology controller					fp_7954_97_61.vsd	Function diagram	
Motorized potentiometer					20.07.2021 V4.7_13	G115D	
- 7954 -							

Fig. 3-142 7954 – Motorized potentiometer

3.18 Signals and monitoring functions

Function diagrams

8005 – Overview	659
8010 – Speed signals 1	660
8011 – Speed signals 2	661
8012 – Torque signals, motor blocked/stalled	662
8013 – Load monitoring (Part 1)	663
8014 – Load monitoring (Part 2)	664
8016 – Thermal monitoring motor, motor temperature status word faults/alarms	665
8017 – Motor temperature model 1 (I2t)	666
8018 – Motor temperature model 2	667
8021 – Thermal monitoring, power unit	668
8022 – Monitoring functions 1	669
8023 – Monitoring functions 2	670

Fig. 3-144 8005 – Overview

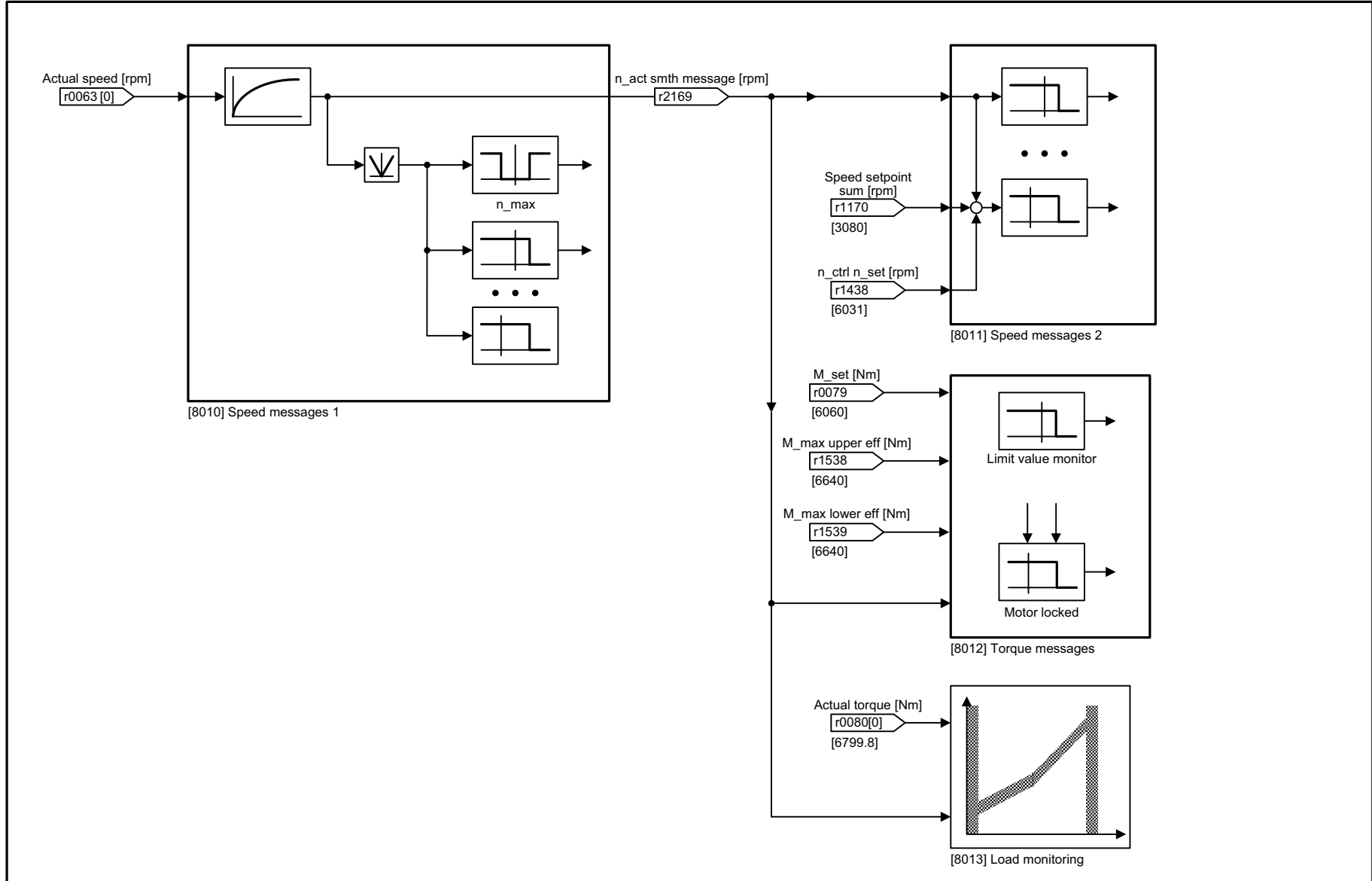

1	2	3	4	5	6	7	8
Signals and monitoring functions					fp_8005_97_53.vsd	Function diagram	
Overview					20.07.2021 V4.7_13	G115D	
- 8005 -							

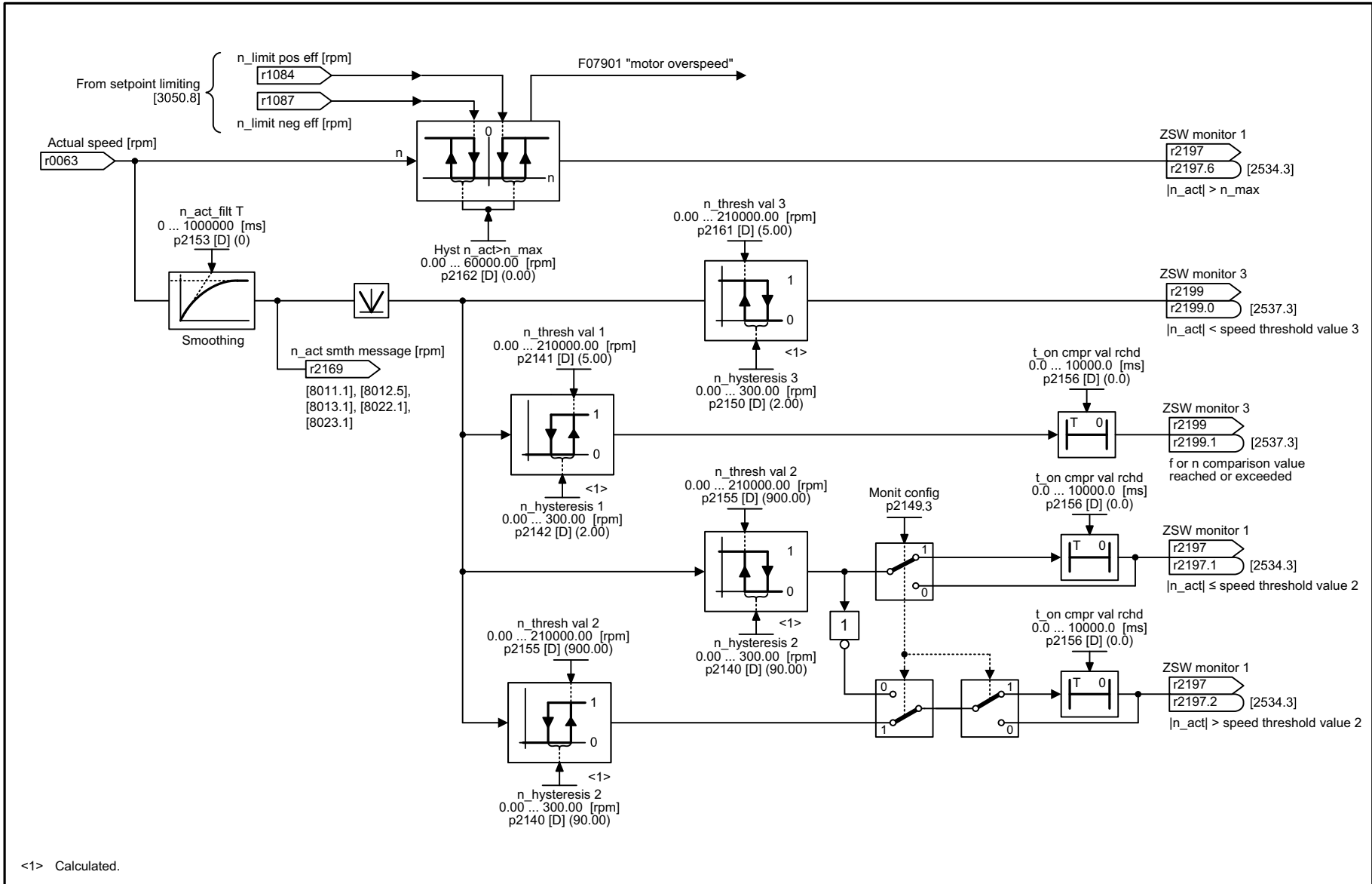

1	2	3	4	5	6	7	8
Signals and monitoring functions					fp_8010_97_53.vsd	Function diagram	
Speed signals 1					20.07.2021 V4.7_13	G115D	

- 8010 -

Fig. 3-145 8010 – Speed signals 1

Fig. 3-146 8011 – Speed signals 2

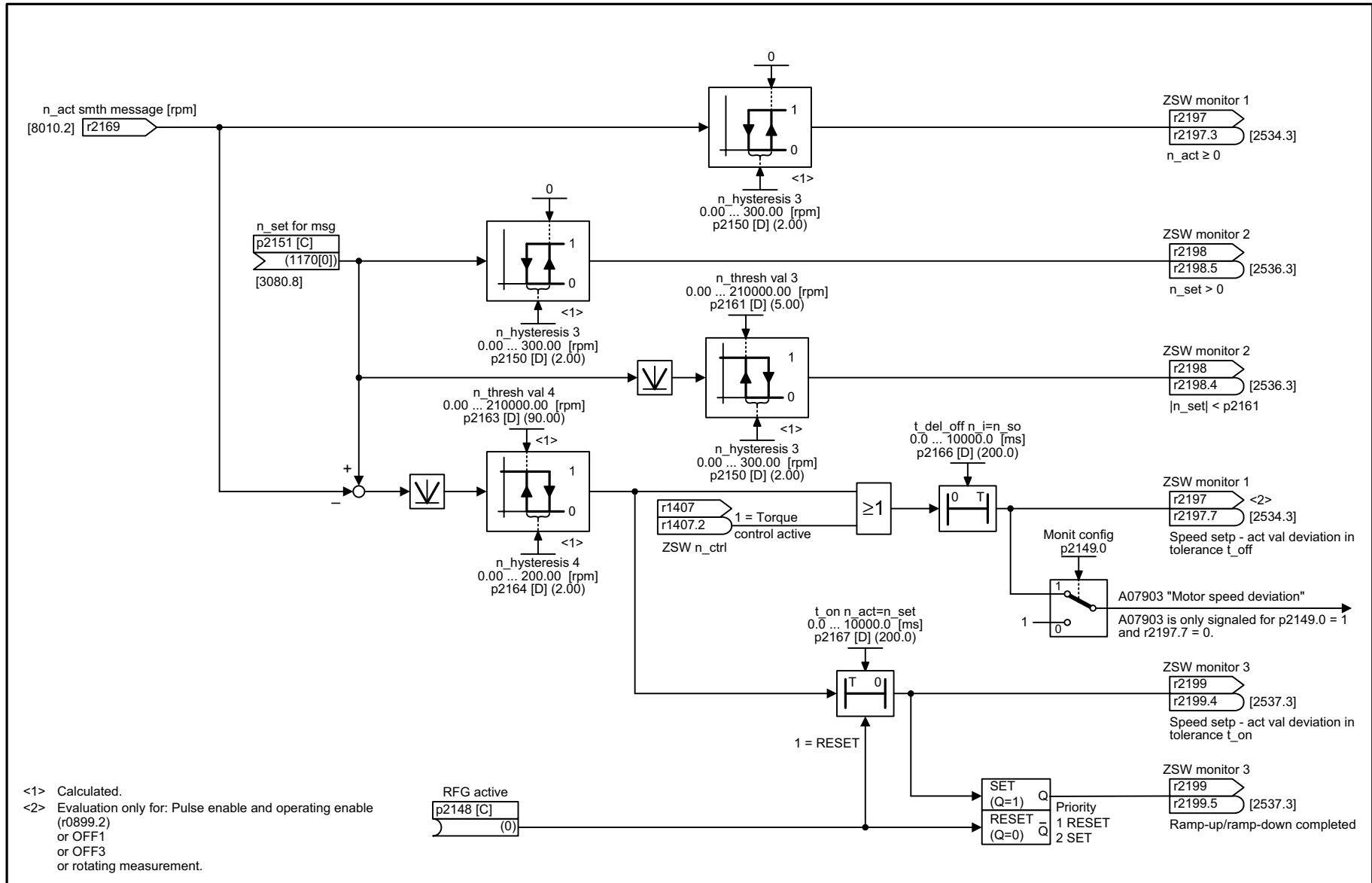

<1> Calculated.
<2> Evaluation only for: Pulse enable and operating enable (r0899.2) or OFF1 or OFF3 or rotating measurement.

1	2	3	4	5	6	7	8
Signals and monitoring functions					fp_8011_97_53.vsd	Function diagram	
Speed signals 2					20.07.2021 V4.7_13	G115D	
- 8011 -							

Fig. 3-147 8012 – Torque signals, motor blocked/stalled

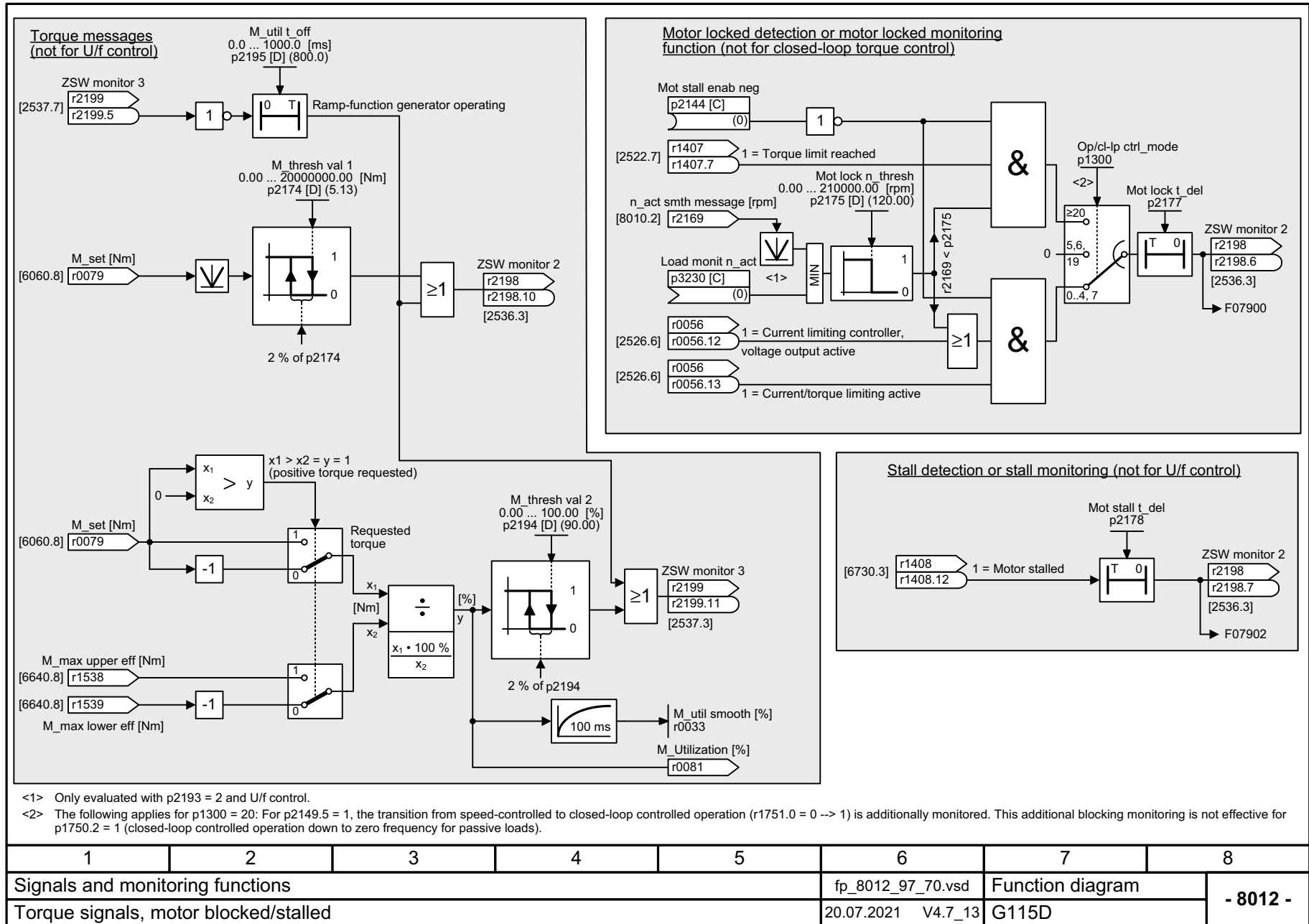
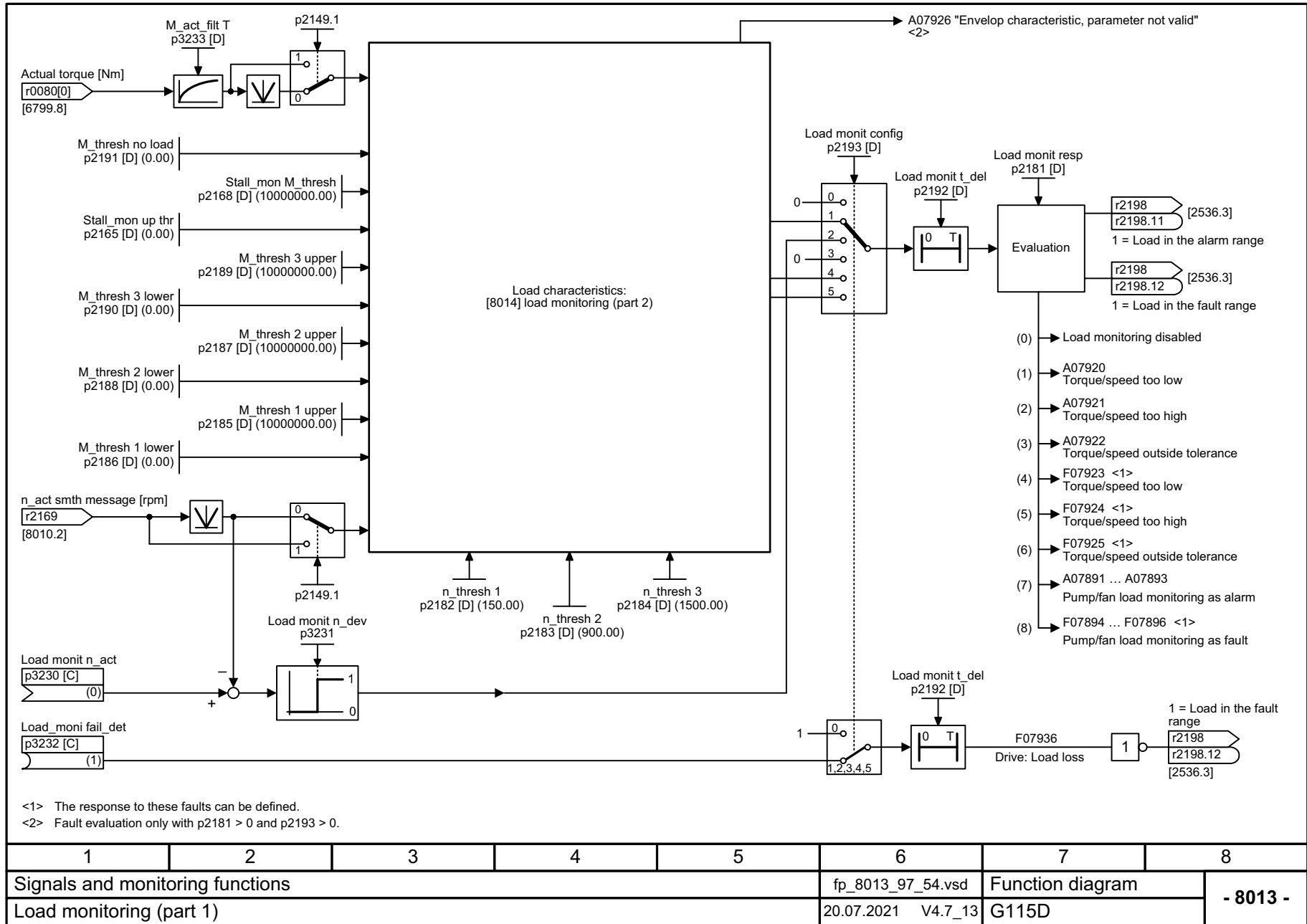
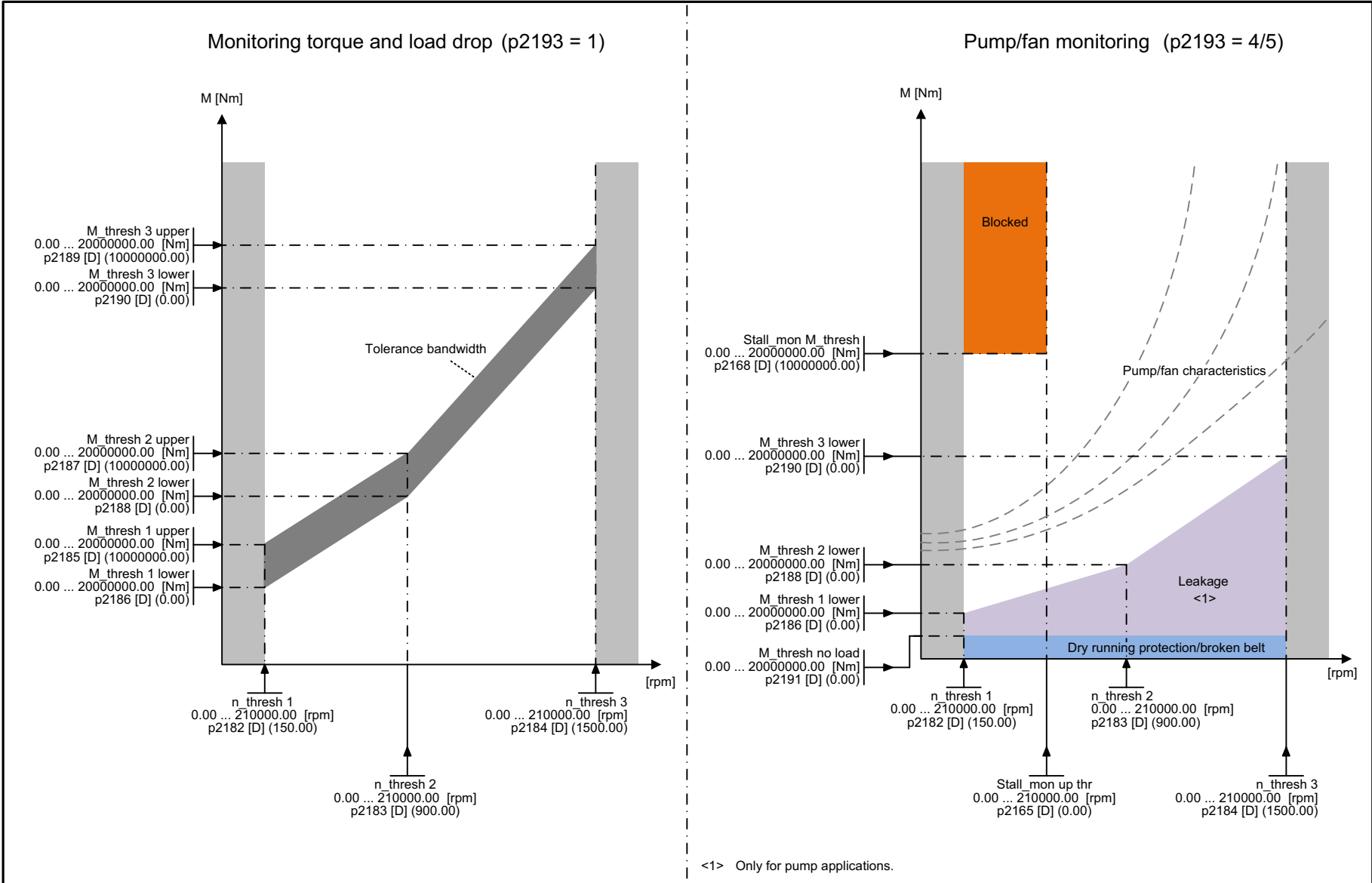

Fig. 3-148 8013 – Load monitoring (Part 1)





1	2	3	4	5	6	7	8
Signals and monitoring functions					fp_8014_97_54.vsd	Function diagram	
Load monitoring (part 2)					20.07.2021 V4.7_13	G115D	

- 8014 -

Fig. 3-149 8014 – Load monitoring (Part 2)

Fig. 3-150 8016 – Thermal monitoring motor, motor temperature status word faults/alarms

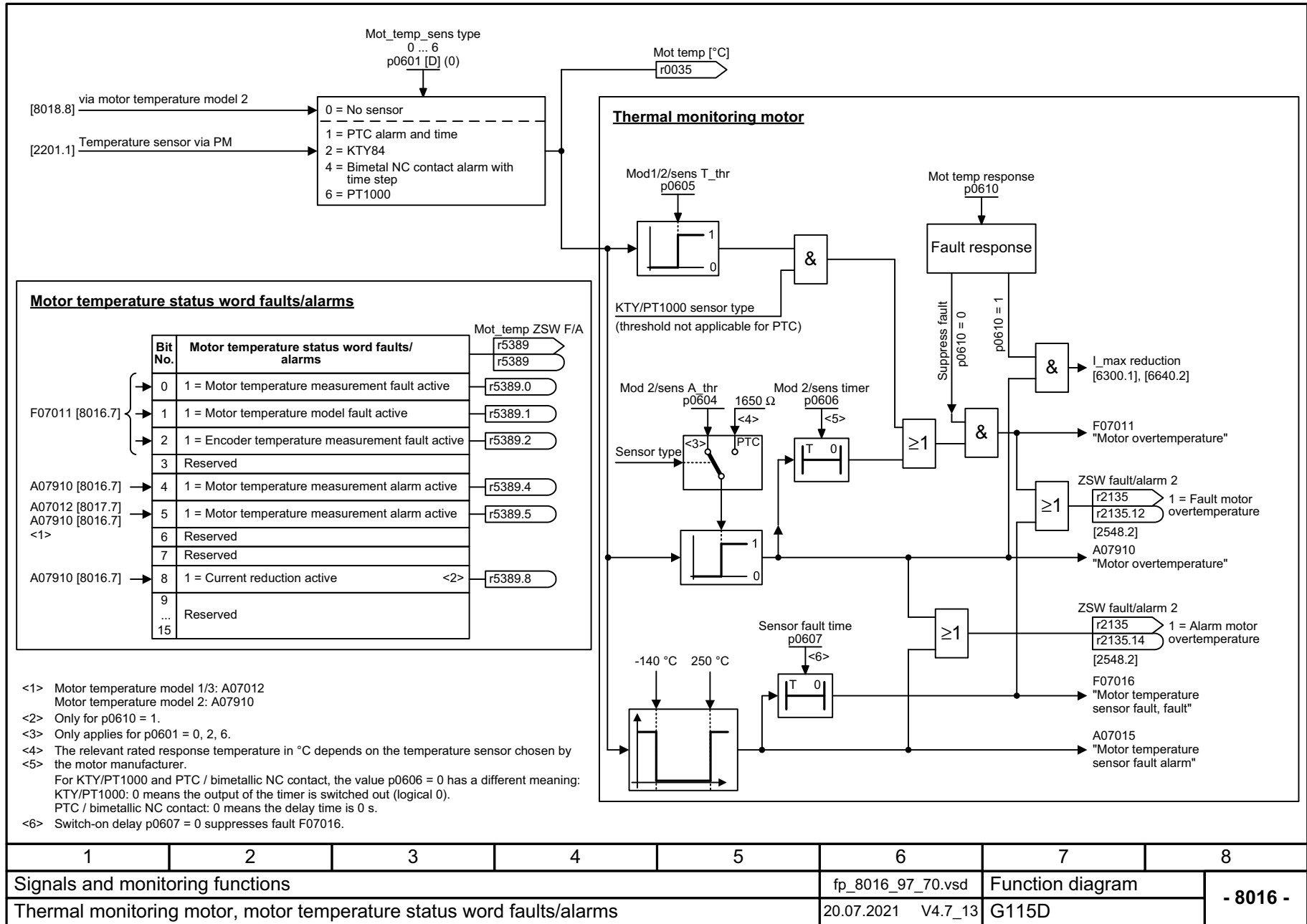

1	2	3	4	5	6	7	8
Signals and monitoring functions					fp_8016_97_70.vsd	Function diagram	
Thermal monitoring motor, motor temperature status word faults/alarms					20.07.2021 V4.7_13	G115D	
- 8016 -							

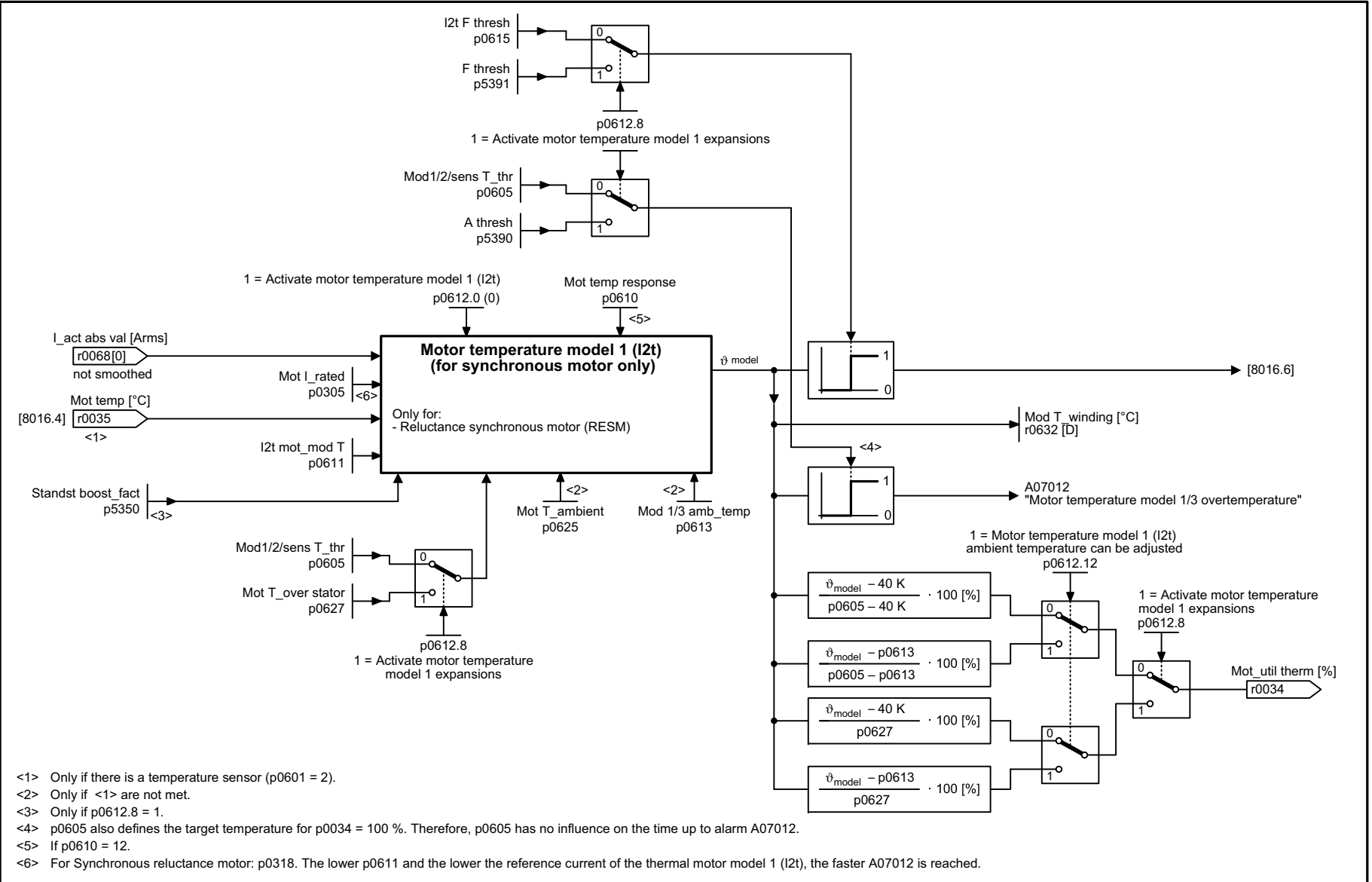

- <1> Only if there is a temperature sensor (p0601 = 2).
- <2> Only if <1> are not met.
- <3> Only if p0612.8 = 1.
- <4> p0605 also defines the target temperature for p0034 = 100 %. Therefore, p0605 has no influence on the time up to alarm A07012.
- <5> If p0610 = 12.
- <6> For Synchronous reluctance motor: p0318. The lower p0611 and the lower the reference current of the thermal motor model 1 (I2t), the faster A07012 is reached.

1	2	3	4	5	6	7	8
Signals and monitoring functions					fp_8017_97_70.vsd	Function diagram	
Motor temperature model 1 (I2t)					20.07.2021 V4.7_13	G115D	
							- 8017 -

Fig. 3-151 8017 – Motor temperature model 1 (I2t)

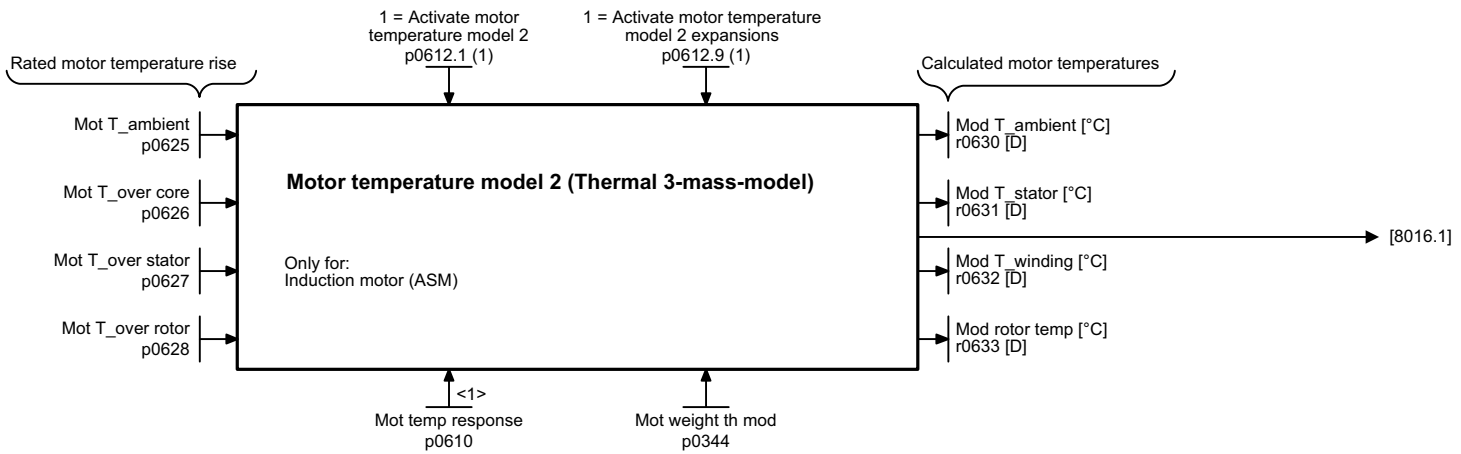

<1> If p0610 = 12.

1	2	3	4	5	6	7	8
Signals and monitoring functions					fp_8018_97_61.vsd	Function diagram	
Motor temperature model 2					20.07.2021 V4.7_13	G115D	
							- 8018 -

Fig. 3-152 8018 – Motor temperature model 2

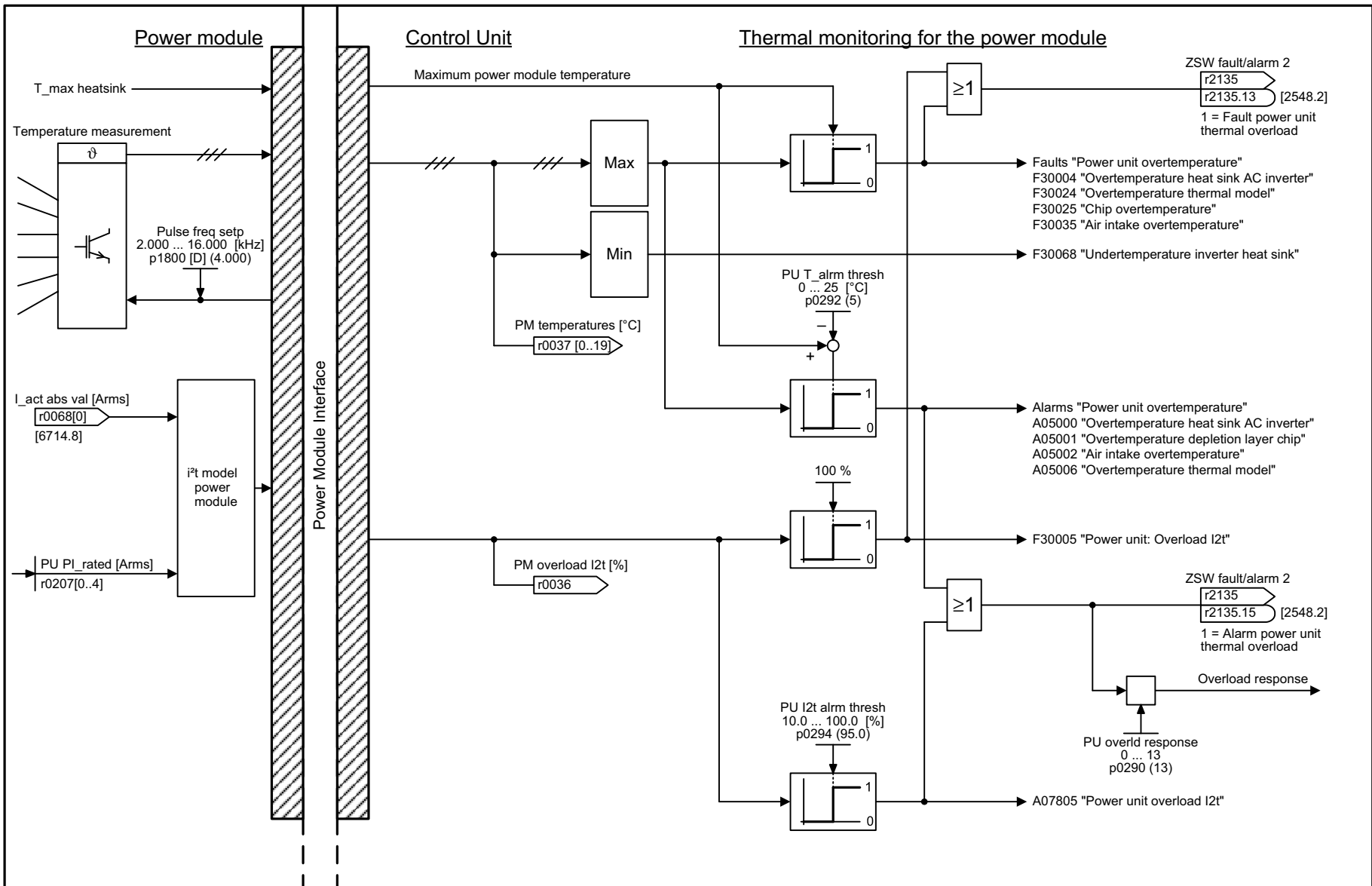

1	2	3	4	5	6	7	8
Signals and monitoring functions					fp_8021_97_51.vsd	Function diagram	
Thermal monitoring, power module					20.07.2021 V4.7_13	G115D	
- 8021 -							

Fig. 3-153 8021 – Thermal monitoring, power unit

Fig. 3-154 8022 – Monitoring functions 1

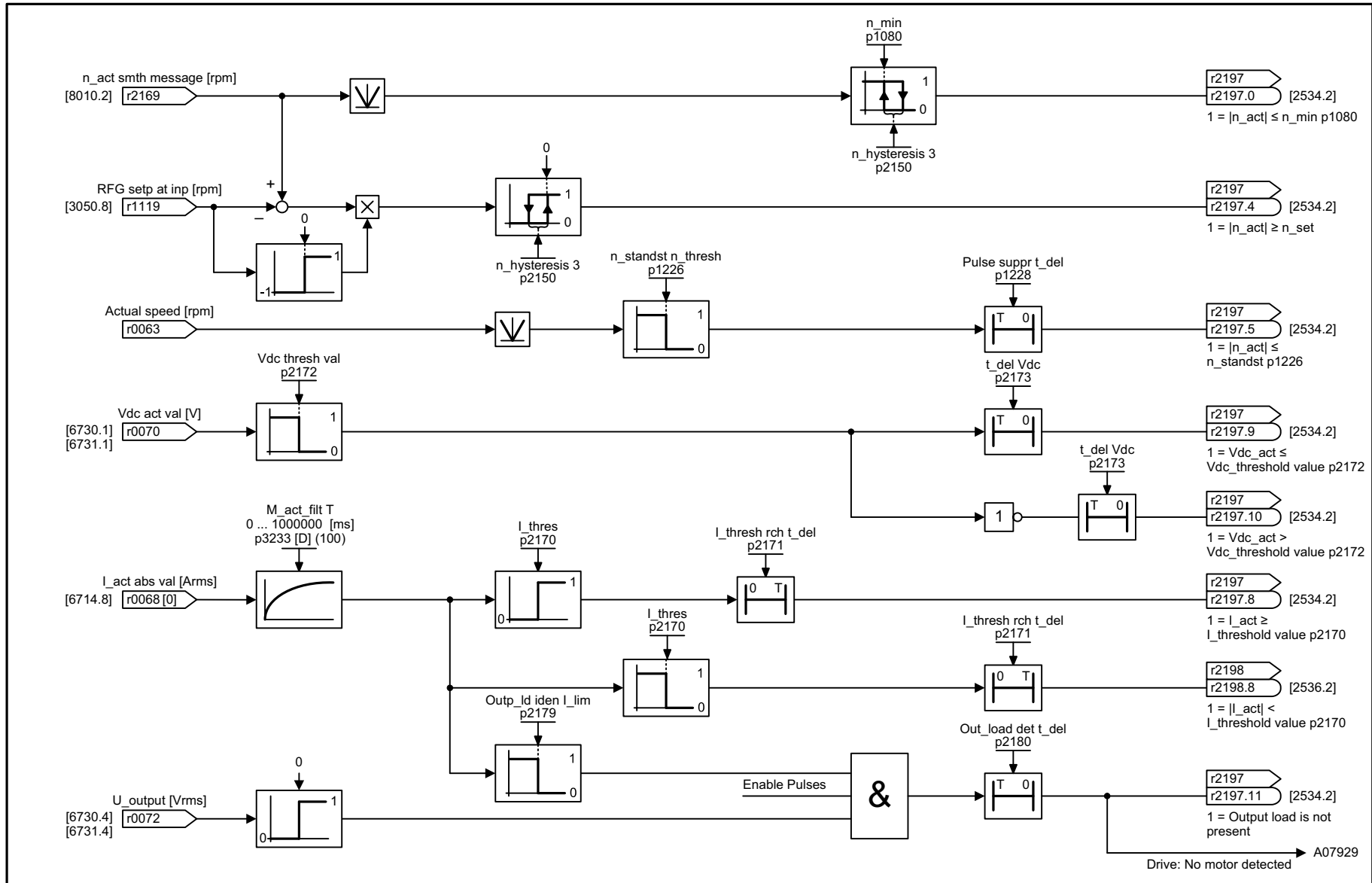

1	2	3	4	5	6	7	8
Signals and monitoring functions					fp_8022_97_70.vsd	Function diagram	
Monitoring functions 1					20.07.2021 V4.7_13	G115D	
							- 8022 -

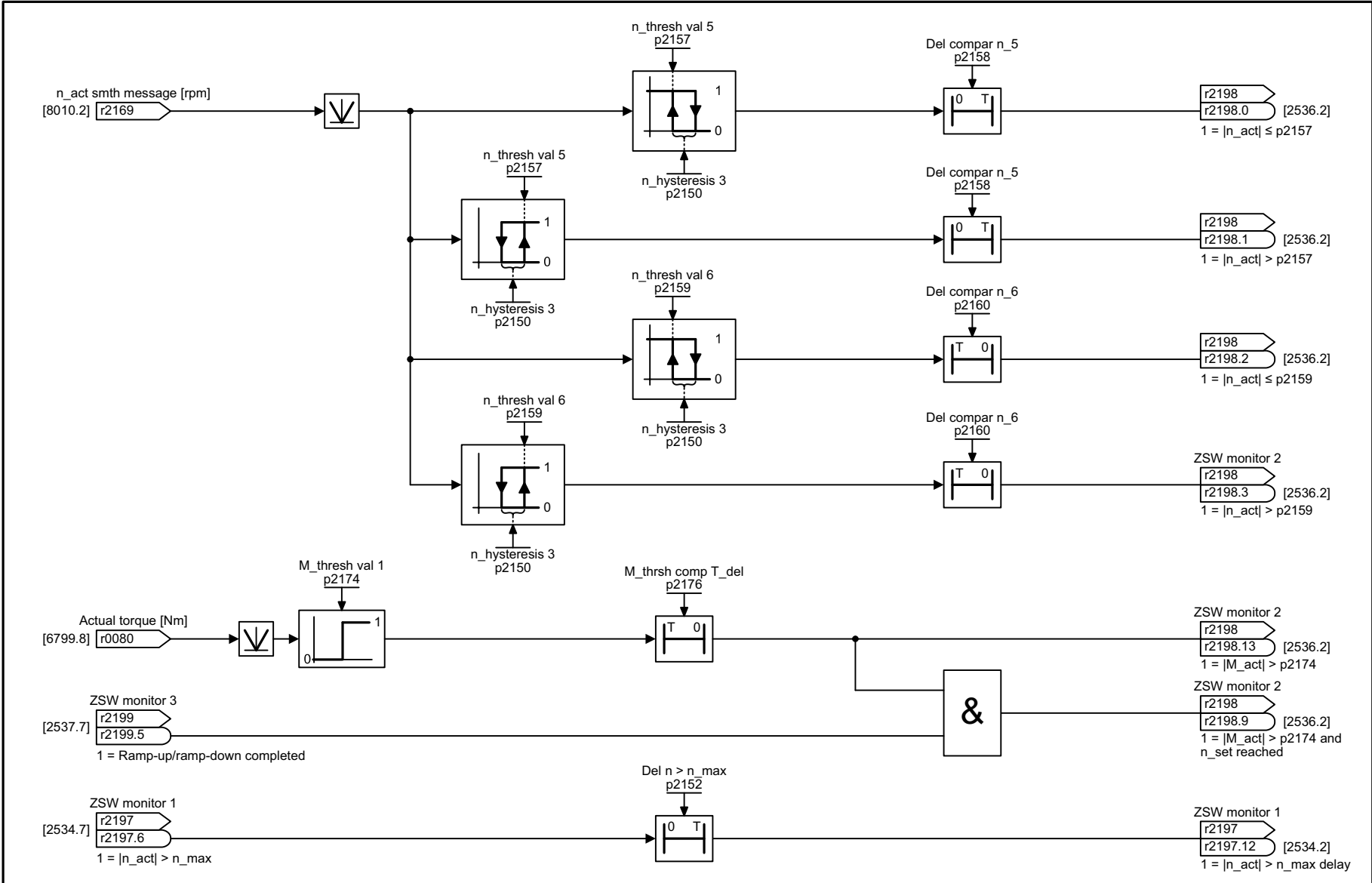

1	2	3	4	5	6	7	8
Signals and monitoring functions					fp_8023_97_53.vsd	Function diagram	
Monitoring functions 2					20.07.2021 V4.7_13	G115D	

- 8023 -

Fig. 3-155 8023 – Monitoring functions 2

3.19 Diagnostics

Function diagrams

8050 – Overview	672
8060 – Fault buffer	673
8065 – Alarm buffer	674
8070 – Faults/alarms trigger word (r2129)	675
8075 – Faults/alarms configuration	676

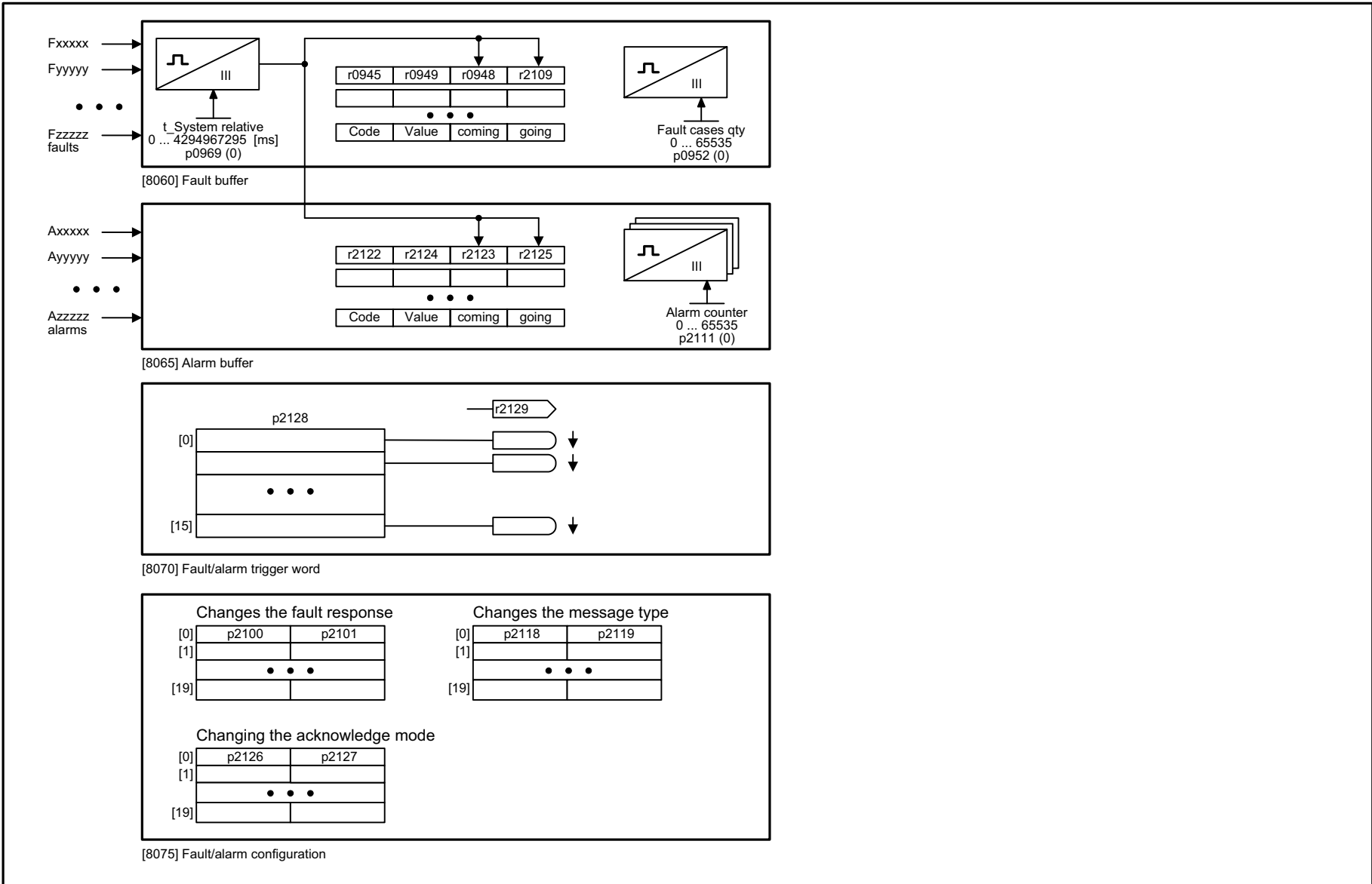

Fig. 3-156 8050 – Overview

1	2	3	4	5	6	7	8
Diagnostics					fp_8050_97_51.vsd	Function diagram	
Overview					20.07.2021 V4.7_13	G115D	
							- 8050 -

Fig. 3-157 8060 – Fault buffer

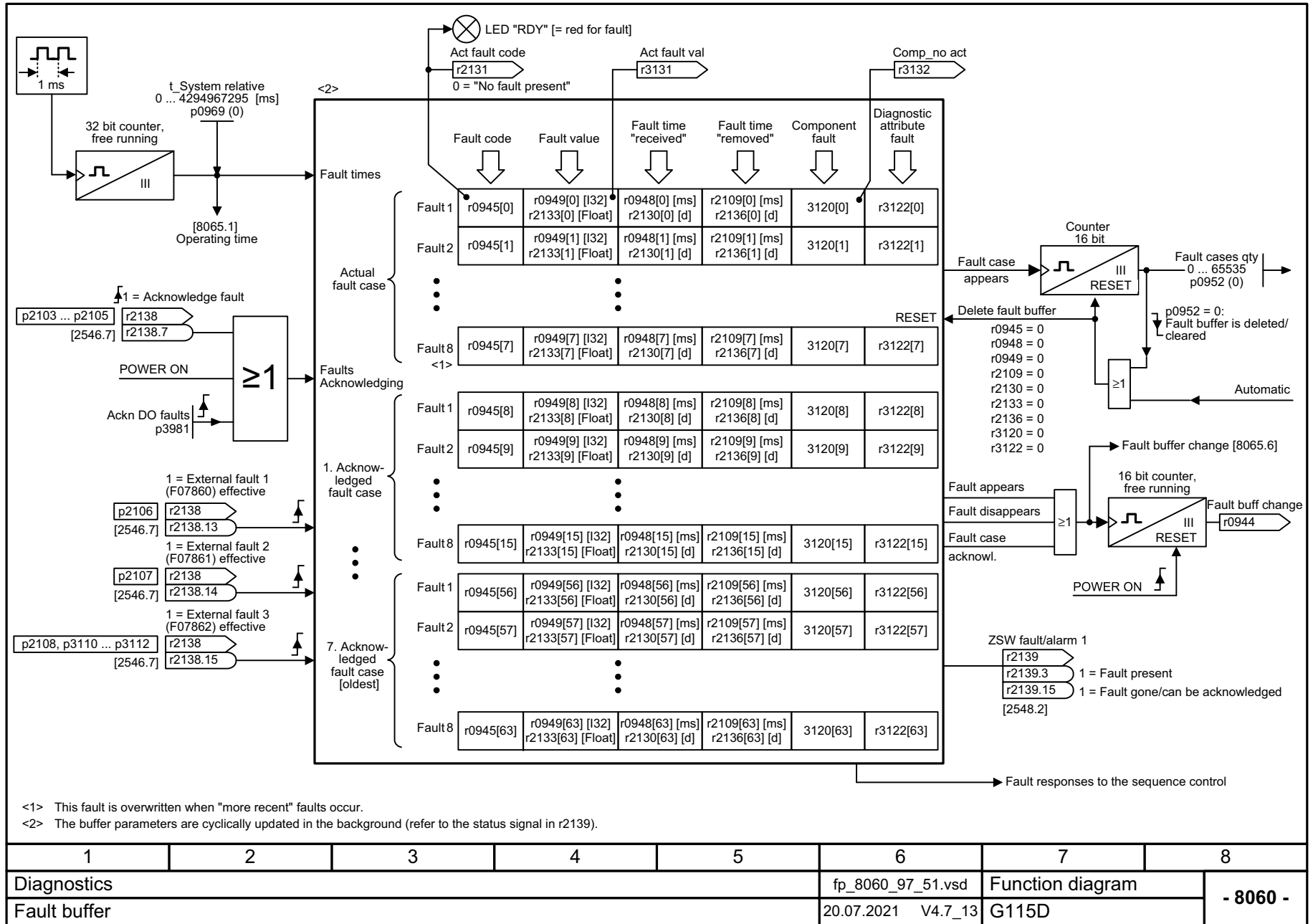
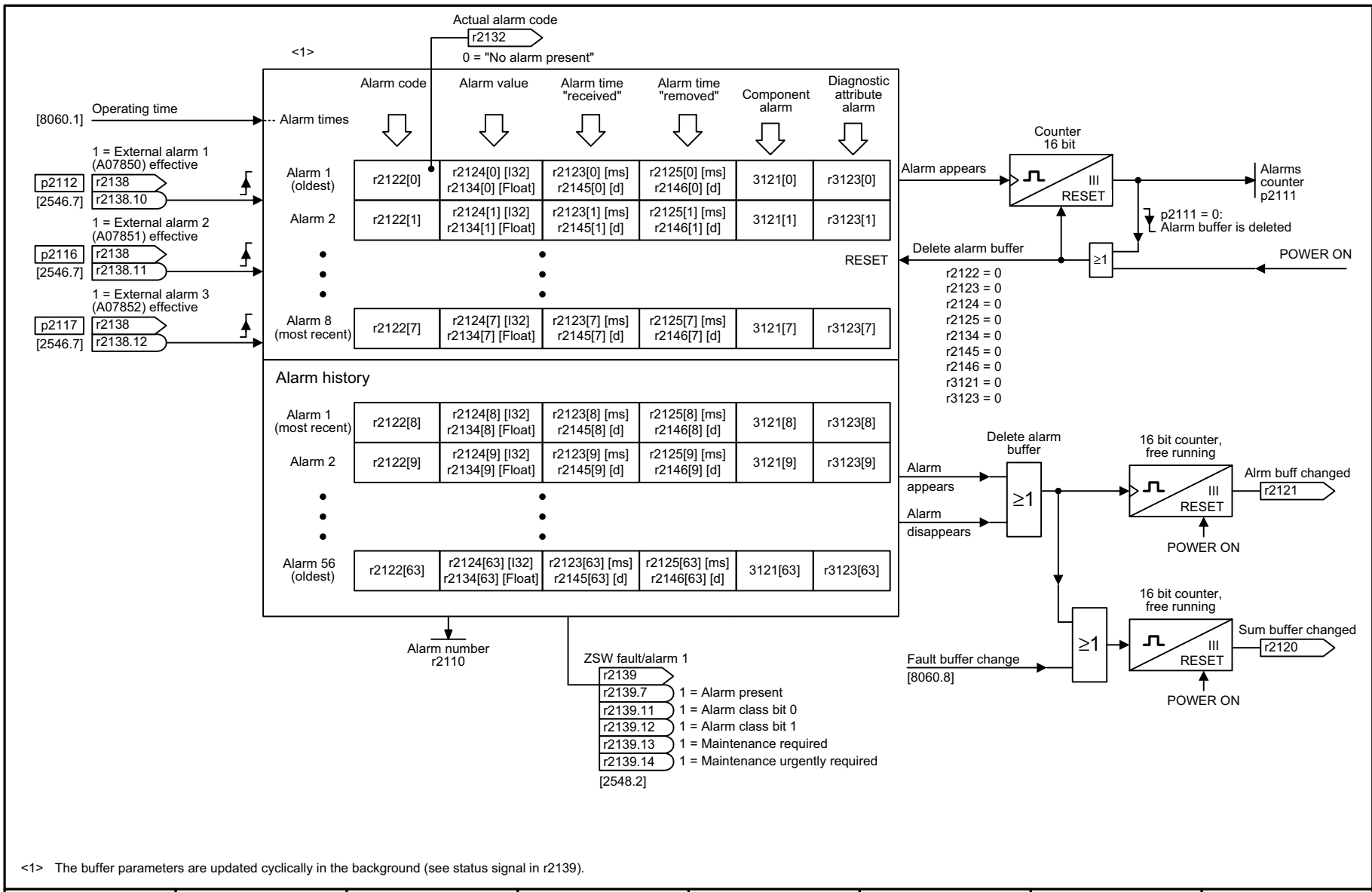

Fig. 3-158 8065 – Alarm buffer



<1> The buffer parameters are updated cyclically in the background (see status signal in r2139).

1	2	3	4	5	6	7	8
Diagnostics					fp_8065_97_51.vsd	Function diagram	
Alarm buffer					20.07.2021 V4.7_13	G115D	

- 8065 -

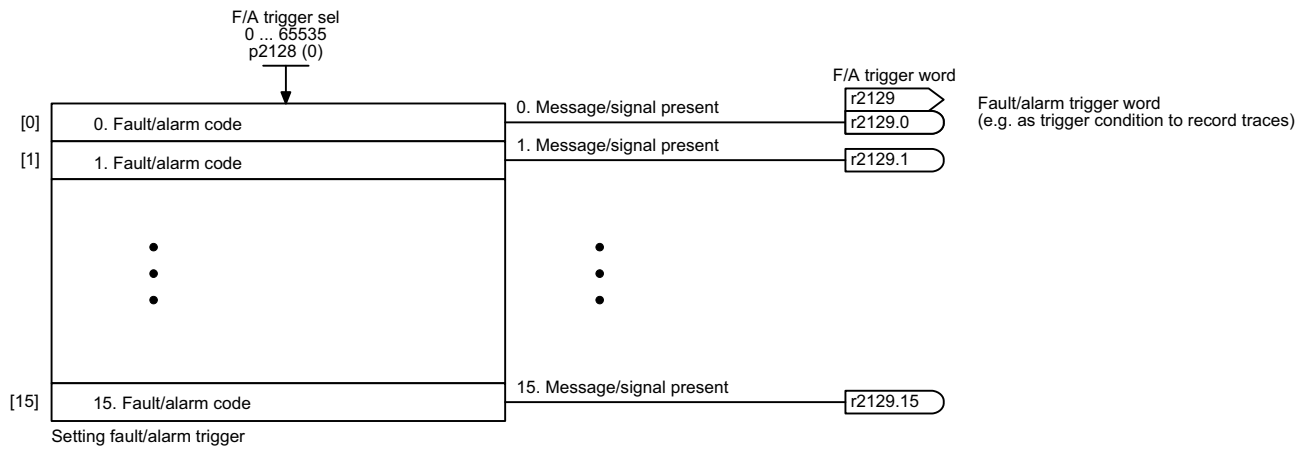

1	2	3	4	5	6	7	8
Diagnostics					fp_8070_97_61.vsd	Function diagram	
Faults/alarms trigger word (r2129)					20.07.2021 V4.7_13	G115D	
- 8070 -							

Fig. 3-159 8070 – Faults/alarms trigger word (r2129)

Changing the message type - fault <=> alarm for maximum 20 faults/alarms <1>

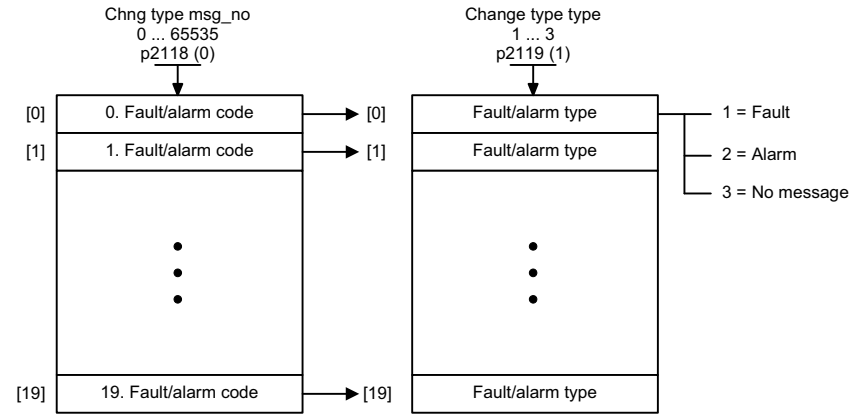

Changing the fault response for maximum 20 faults <1>

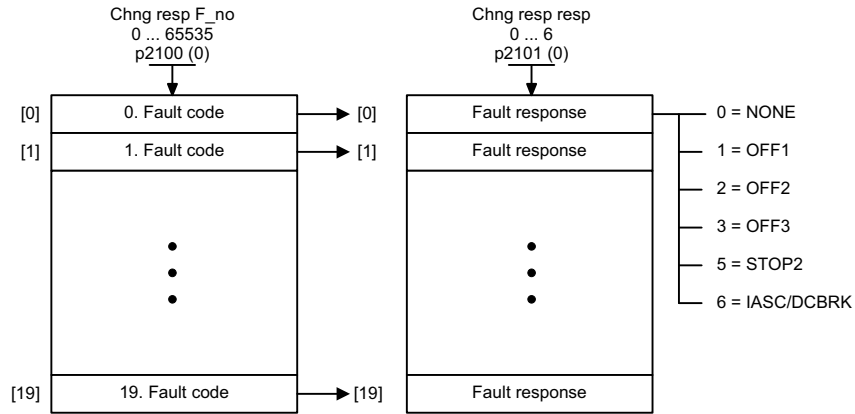

Changing the acknowledge mode for maximum 20 faults <1>

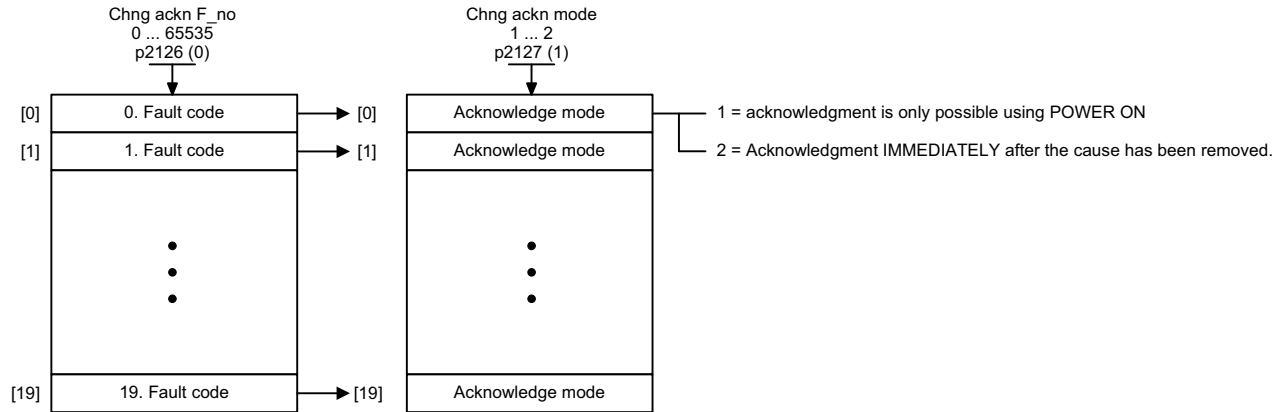

<1> The fault response, acknowledge mode and message type for all faults and alarms are set to meaningful default values in the factory setting. Changes are only possible in specific value ranges specified by SIEMENS. When the message type is changed, the supplementary information is transferred from fault value r0949 to alarm value r2124 and vice versa.

DCBRK = DC Brake
IASC = Internal Armature Short-Circuit

1	2	3	4	5	6	7	8
Diagnostics					fp_8075_97_51.vsd	Function diagram	
Faults/alarms configuration					20.07.2021 V4.7_13	G115D	
							- 8075 -

Fig. 3-160 8075 – Faults/alarms configuration

3.20 Data sets

Function diagrams

8560 – Command Data Sets (CDS)	678
8565 – Drive Data Sets (DDS)	679

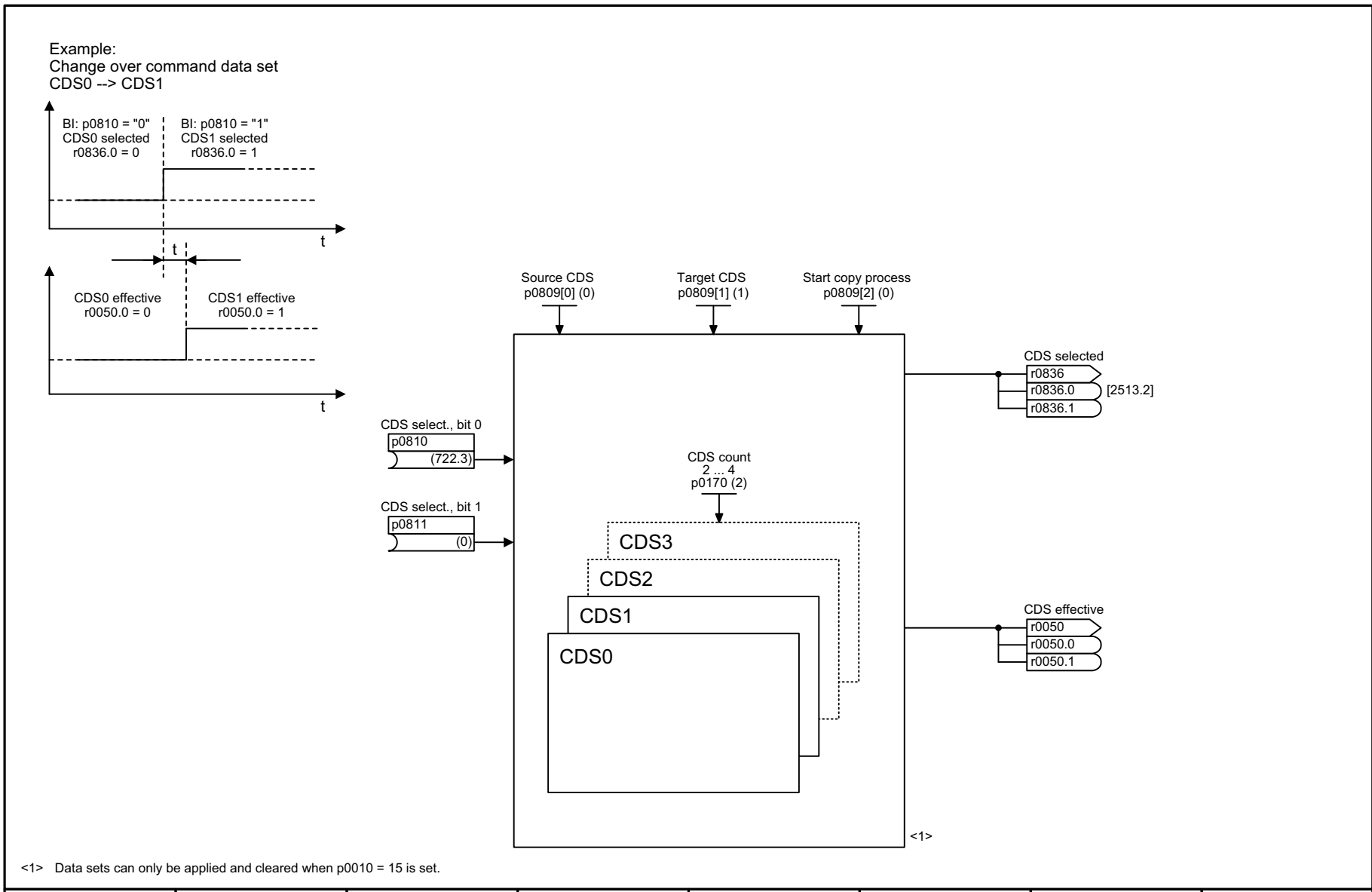

<1> Data sets can only be applied and cleared when p0010 = 15 is set.

1	2	3	4	5	6	7	8
Data sets					fp_8560_97_51.vsd	Function diagram	
Command Data Sets (CDS)					20.07.2021 V4.7_13	G115D	
							- 8560 -

Fig. 3-161 8560 – Command Data Sets (CDS)

Fig. 3-162 8565 – Drive Data Sets (DDS)

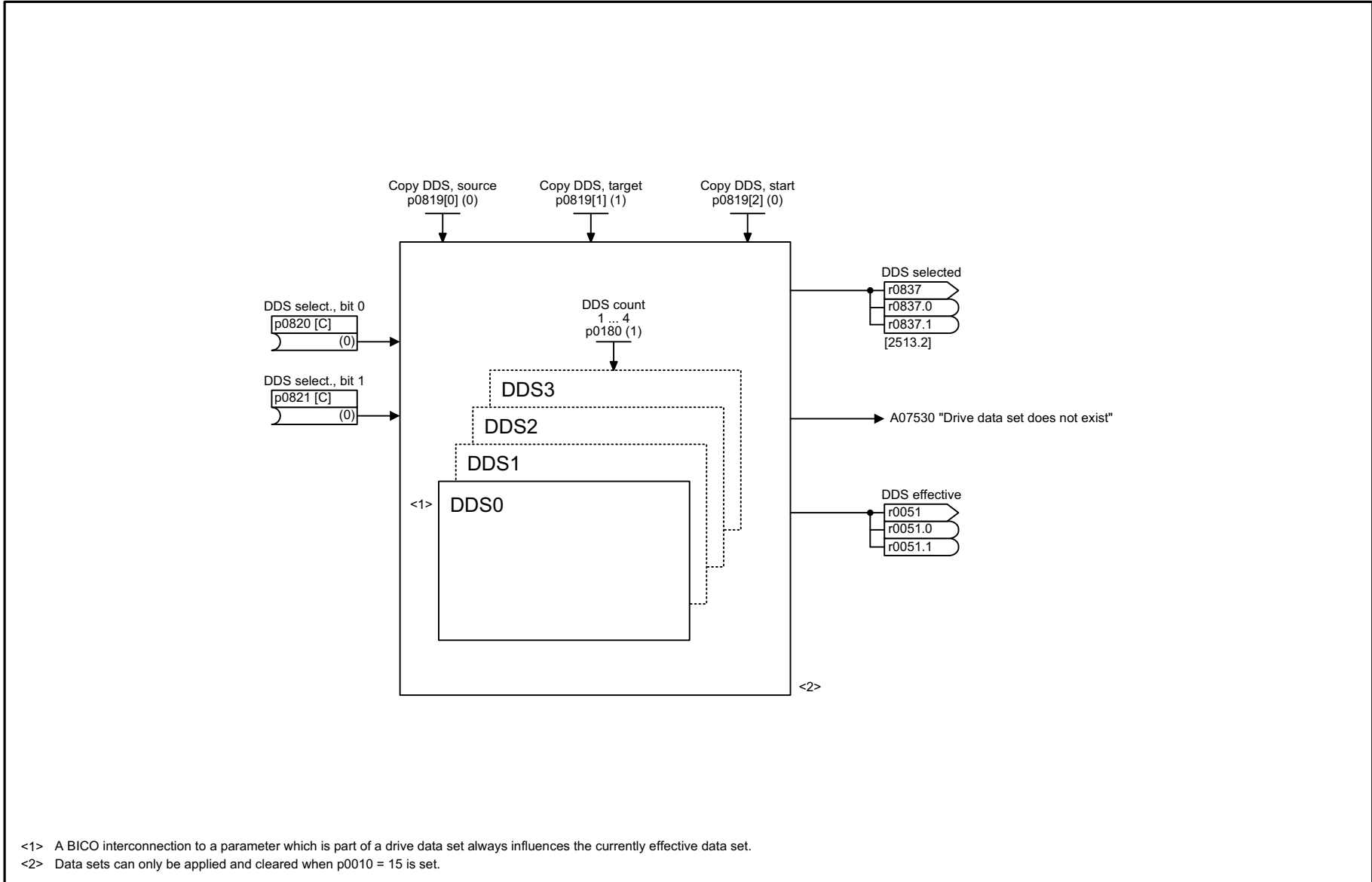

<1> A BICO interconnection to a parameter which is part of a drive data set always influences the currently effective data set.
<2> Data sets can only be applied and cleared when p0010 = 15 is set.

1	2	3	4	5	6	7	8
Data sets					fp_8565_97_54.vsd	Function diagram	
Drive Data Sets (DDS)					20.07.2021 V4.7_13	G115D	
							- 8565 -

Faults and alarms

Content

4.1	Overview of faults and alarms	682
4.2	List of faults and alarms	693

4.1 Overview of faults and alarms

4.1.1 General

Fault and alarm displays (messages)

In the case of a fault, the drive signals the corresponding fault(s) and/or alarm(s).

For example, the following methods for displaying faults and alarms are available:

- Display via the fault and alarm buffer with PROFIBUS/PROFINET
- Display online via the commissioning software
- Display and operating unit (e.g. BOP, AOP)

Differences between faults and alarms

The differences between faults and alarms are as follows:

Table 4-1 Differences between faults and alarms

Type	Description
Faults	<p>What happens when a fault occurs?</p> <ul style="list-style-type: none"> • The appropriate fault response is triggered. • Status bit ZSW1.3 is set. • The fault is entered in the fault buffer. <p>How are faults eliminated?</p> <ul style="list-style-type: none"> • Remove the original cause of the fault. • Acknowledge the fault.
Alarms	<p>What happens when an alarm occurs?</p> <ul style="list-style-type: none"> • Status signal ZSW1.7 is set. • The alarm is entered into the alarm buffer. <p>How are alarms eliminated?</p> <ul style="list-style-type: none"> • Alarms acknowledge themselves. If the cause of the alarm is no longer present, they automatically reset themselves.

Fault reactions

The following fault reactions are defined:

Table 4-2 Fault reactions

List	PROFIdrive	Reaction	Description
NONE	-	None	<p>No response when a fault occurs.</p> <p>Note</p> <p>With "Basic positioner" (r0108.4 = 1), the following applies: When a fault occurs with fault reaction "NONE", an active traversing task is interrupted and the system switches to tracking mode until the fault has been rectified and acknowledged.</p>
OFF1	ON/ OFF	Brake along the ramp-function generator down ramp followed by pulse inhibit	<p>Speed control (p1300 = 20)</p> <ul style="list-style-type: none"> • n_set = 0 is input immediately to brake the drive along the ramp-function generator ramp down (p1121). • When zero speed is detected, the motor holding brake (if parameterized) is closed (p1215). The pulses are suppressed when the brake application time (p1217) expires. <p>Zero speed is detected if the actual speed drops below the threshold (p1226) or if the monitoring time (p1227) started when speed setpoint <= speed threshold (p1226) has expired.</p> <p>Closed loop torque control (p1300 = 22)</p> <ul style="list-style-type: none"> • The following applies for closed-loop torque control: Reaction as for OFF2. • When the system switches to closed-loop torque control with p1501, the following applies: No separate braking reaction. <p>If the actual speed value drops below the speed threshold (p1226) or the timer stage (p1227) has expired, the motor holding brake (if one is being used) is closed. The pulses are suppressed when the brake application time (p1217) expires.</p>
OFF1_ DELAYED	-	As for OFF1, however delayed	<p>Faults with this fault response only become effective after the delay time in p3136 has expired.</p> <p>The remaining time up to OFF1 is displayed in r3137.</p>
OFF2	COAST STOP	Internal/external pulse disable	<p>Speed and torque control</p> <ul style="list-style-type: none"> • Instantaneous pulse suppression, the drive "coasts" to a standstill. • The motor holding brake (if one is being used) is closed immediately. • Switching-on inhibited is activated.

Table 4-2 Fault reactions, continued

List	PROFIdrive	Reaction	Description
OFF3	QUICK STOP	Brake along the OFF3 down ramp followed by pulse disable	<p>Speed control (p1300 = 20)</p> <ul style="list-style-type: none"> n_set = 0 is input immediately to brake the drive along the OFF3 ramp down (p1135). When zero speed is detected, the motor holding brake (if parameterized) is closed. The pulses are suppressed when the holding brake's closing time (p1217) expires. <p>Zero speed is detected if the actual speed drops below the threshold (p1226) or if the monitoring time (p1227) started when speed setpoint <= speed threshold (p1226) has expired.</p> <ul style="list-style-type: none"> Switching-on inhibited is activated. <p>Closed loop torque control (p1300 = 22)</p> <ul style="list-style-type: none"> Changeover to speed-controlled operation and other reactions as described for speed-controlled operation.
STOP2	-	n_set = 0	<ul style="list-style-type: none"> n_set = 0 is input immediately to brake the drive along the OFF3 ramp down (p1135). The drive remains in closed-loop speed control.
IASC/DCBRK	-	-	<ul style="list-style-type: none"> For synchronous motors, the following applies: If a fault occurs with this fault reaction, an internal armature short-circuit is triggered. The conditions for p1231 = 4 must be observed. For induction motors, the following applies: If a fault occurs with this fault reaction, DC braking is triggered. DC braking must have been commissioned (p1230 to p1239).

Acknowledging faults

The list of faults and alarms specifies how to acknowledge each fault after the cause has been eliminated.

Table 4-3 Acknowledging faults

Acknowledgment	Description
POWER ON	<p>The fault is acknowledged via a POWER ON (switch Control Unit off and on again).</p> <p>Note If this action has not removed the fault cause, the fault is displayed again immediately after power up.</p>
IMMEDIATELY	<p>Faults can be acknowledged as follows:</p> <p>1 Set acknowledgment by parameter: p3981 = 0 --> 1</p> <p>2 Acknowledging via binector inputs:</p> <p>p2103 BI: 1 Acknowledge faults p2104 BI: 2 Acknowledge faults p2105 BI: 3 Acknowledge faults</p> <p>3 Acknowledging via a PROFIdrive control signal: STW1.7 = 0 --> 1 (edge)</p> <p>Note</p> <ul style="list-style-type: none"> • These faults can also be acknowledged by a POWER ON operation. • If this action has not eliminated the fault cause, the fault will continue to be displayed after acknowledgment. • Safety Integrated faults The "Safe Torque Off" (STO) function must be deselected before these faults are acknowledged.
PULSE SUPPRESSION	<p>The fault can only be acknowledged when the pulses are inhibited (r0899.11 = 0). The same options are available for acknowledging as described under IMMEDIATE acknowledgment.</p>

4.1.2 Explanation of the list of faults and alarms

The data in the following example have been chosen at random. The information listed below is the maximum amount of information that a description can contain. Some of the information is optional.

The "List of faults and alarms (Page 693)" has the following layout:

----- **Start of example** -----

	Axxxxx (F, N)	Fault location (optional): Name
Message class:	Text of the message class (number according to PROFIdrive)	
Reaction:	NONE	
Acknowledgement:	NONE	
Cause:	Description of possible causes. Fault value (r0949, interpret format): or alarm value (r2124, interpret format): (optional) Information about fault or alarm values (optional).	
Remedy:	Description of possible remedies.	

----- **End of example** -----

Axxxxx	Alarm xxxxx
Axxxxx (F, N)	Alarm xxxxx (message type can be changed in F or N)
Fxxxxx	Fault xxxxx
Fxxxxx (A, N)	Fault xxxxx (message type can be changed in A or N)
Nxxxxx	No message
Nxxxxx (A)	No message (message type can be changed in A)

A message comprises a letter followed by the relevant number.

The meaning of the letters is as follows:

- A means "Alarm"
- F means "Fault"
- N means "No message" or "Internal message"

The optional brackets indicate whether the type specified for this message can be changed and which message types can be adjusted via parameters (p2118, p2119).

Information on reaction and acknowledgment is specified independently for a message with an adjustable message type (e.g. reaction to F, acknowledgment for F).

Note

You can change the default properties of a fault or alarm by setting parameters.

References: SINAMICS G115D Operating Instructions
Chapter "Alarms, faults and system messages"

The "List of faults and alarms (Page 693)" supplies information referred to the properties of a message set as default. If the properties of a specific message are changed, the corresponding information may have to be modified in this list.

Fault location (optional): Name

The fault location (optional), the name of the fault or alarm and the message number are all used to identify the message (e.g. with the commissioning software).

Message class:

For each message, specifies the associated message class with the following structure:

Text of the message class (number according to PROFIdrive)

The message classes are transferred at different interfaces to higher-level control systems and their associated display and operating units.

The message classes that are available are shown in Table "Message classes and coding of various diagnostic interfaces (Page 688)". In addition to the text of the message class and their number according to PROFIdrive – as well as a brief help text regarding the cause and remedy – they also include information about the various diagnostic interfaces:

- PN (hex)

Specifies the "Channel error type" of the PROFINET channel diagnostics.

When activating the channel diagnostics, using the GSDML file, the texts listed in the table can be displayed.
- DS1 (dec)

Specifies the bit number in data set DS1 of the diagnostic alarm for SIMATIC S7.

When the diagnostic alarms are activated, the texts listed in the table can be displayed.
- DP (dec)

Specifies the "Error type" of the channel-related diagnostics for PROFIBUS.

When the channel diagnostics are activated, the texts listed in the standard and the GSD file can be displayed.
- ET 200 (dec)

Specifies the "Error type" of the channel-related diagnostics for the SIMATIC ET 200pro FC-2 device.

When the channel diagnostics are activated, the texts listed in the standard and the GSD file of the ET 200pro can be displayed.
- NAMUR (r3113.x)

Specifies the bit number in parameter r3113.

For the interfaces DP, ET 200, NAMUR, in some instances, the message classes are combined.

4 Faults and alarms

4.1 Overview of faults and alarms

Table 4-4 Message classes and coding of various diagnostic interfaces

Text of the message class (number according to PROFIdrive) Cause and remedy.	Diagnostics interface				
	PN (hex)	DS1 (dec)	DP (dec)	ET 200 (dec)	NAMUR (r3113.x)
Hardware/software errors (1) A hardware or software malfunction was detected. Carry out a POWER ON for the relevant component. If it occurs again, contact the hotline.	9000	0	16	9	0
Line fault (2) A line supply fault has occurred (phase failure, voltage level ...). Check the line supply and fuses. Check the supply voltage. Check the wiring.	9001	1	17	24	1
Supply voltage fault (3) An electronics supply voltage fault (48 V, 24 V, 5 V ...) was detected. Check the wiring. Check the voltage level.	9002	2	2 ¹ 3 ²	2 ¹ 3 ²	15
DC-link overvoltage (4) The DC-link voltage has assumed an inadmissibly high value. Check the dimensioning of the system (line supply, reactor, voltages). Check the infeed settings.	9003	3	18	24	2
Power electronics fault (5) An impermissible operating state of the power electronics was detected (overcurrent, overtemperature, IGBT failure ...). Check compliance with the permissible load cycles. Check the ambient temperatures (fan).	9004	4	19	24	3
Overtemperature of the electronic component (6) The temperature in the component has exceeded the highest permissible limit. Check the ambient temperature / control cabinet ventilation.	9005	5	20	5	4
Ground fault / inter-phase short-circuit detected (7) A ground fault / inter-phase short-circuit was detected in the power cables or in the motor windings. Check the power cables (connection). Check the motor.	9006	6	21	20	5
Motor overload (8) The motor was operated outside the permissible limits (temperature, current, torque ...). Check the load cycles and set limits. Check the ambient temperature / motor cooling.	9007	7	22	24	6
Communication to the higher-level controller faulted (9) The communication to the higher-level controller (internal coupling, PROFIBUS, PROFINET ...) is faulted or interrupted. Check the state of the higher-level controller. Check the communication connection/-wiring. Check the bus configuration/cycles.	9008	8	23	19	7
Safety monitoring channel has detected an error (10) A safe operation monitoring function has detected an error.	9009	9	24	25	8
Actual position/speed value incorrect or not available (11) An illegal signal state was detected while evaluating the encoder signals (track signals, zero marks, absolute values ...). Check the encoder / state of the encoder signals. Observe the maximum permissible frequencies.	900A	10	25	29	9

Table 4-4 Message classes and coding of various diagnostic interfaces, continued

Text of the message class (number according to PROFIdrive) Cause and remedy.	Diagnostics interface				
	PN (hex)	DS1 (dec)	DP (dec)	ET 200 (dec)	NAMUR (r3113.x)
Internal (DRIVE-CLiQ) communication faulted (12) The internal communication between the SINAMICS components is faulted or interrupted. Check the DRIVE-CLiQ wiring. Ensure an EMC-compliant installation. Observe the maximum permissible quantity structures / cycles.	900B	11	26	31	10
Infeed fault (13) The infeed is faulty or has failed. Check the infeed and its environment (line supply, filters, reactors, fuses ...). Check the infeed control.	900C	12	27	24	11
Braking controller / Braking Module faulted (14) The internal or external Braking Module is faulted or overloaded (temperature). Check the connection/state of the Braking Module. Comply with the permissible number of braking operations and their duration.	900D	13	28	24	15
Line filter fault (15) The line filter monitoring has detected an excessively high temperature or another impermissible state. Check the temperature / temperature monitoring. Check the configuration to ensure that it is permissible (filter type, infeed, thresholds).	900E	14	17	24	15
External measured value / signal state outside of the permissible range (16) A measured value / signal state read in via the input area (digital/analog/temperature) has assumed an impermissible value/state. Identify and check the relevant signal. Check the set thresholds.	900F	15	29	26	15
Application / technological function faulty (17) The application / technological function has exceeded a (set) limit (position, velocity, torque ...). Identify and check the relevant limit. Check the setpoint specification of the higher-level controller.	9010	16	30	9	15
Error in the parameterization/configuration/commissioning procedure (18) An error was identified in the parameterization or in a commissioning procedure, or the parameterization does not match the actual device configuration. Determine the precise cause of the fault using the commissioning tool. Adapt the parameterization or device configuration.	9011	17	31	16	15
General drive fault (19) Group fault. Determine the precise cause of the fault using the commissioning tool.	9012	18	9	9	15
Auxiliary unit fault (20) The monitoring of an auxiliary unit (incoming transformer, cooling unit ...) has detected an illegal state. Determine the exact cause of the fault and check the relevant device.	9013	19	29	26	15

1. Undervoltage condition of the electronics power supply
2. Overvoltage condition of the electronics power supply

Reaction: Default fault reaction (adjustable fault reaction)

Specifies the default reaction in the event of a fault.

The optional parentheses indicate whether the default fault reactions can be changed and which fault reactions can be adjusted via parameters (p2100, p2101).

Note

See Table "Fault reactions (Page 683)"

Acknowledgment: Default acknowledgment (adjustable acknowledgment)

Specifies the default method of acknowledging faults after the cause has been eliminated.

The optional parentheses indicate whether the default acknowledgment can be changed and which acknowledgment can be adjusted via parameters (p2126, p2127).

Note

See Table "Acknowledging faults (Page 685)"

Cause:

Describes the possible causes of the fault or alarm. A fault or alarm value can also be specified (optional).

Fault value (r0949, format):

The fault value is entered in the fault buffer in r0949[0...63] and specifies additional, more precise information about a fault.

Alarm value (r2124, format):

The alarm value specifies additional, more precise information about an alarm.

The alarm value is entered in the alarm buffer in r2124[0...63] and specifies additional, more precise information about an alarm.

Remedy:

Describes the methods available for eliminating the cause of the active fault or alarm.

 WARNING
On a case for case basis, service and maintenance personnel are responsible for choosing a suitable method for eliminating the cause of faults.

4.1.3 Number ranges of faults and alarms

Note

The following number ranges represent an overview of all faults and alarms used in the SINAMICS drive family.

The faults and alarms for the product described in this List Manual are described in detail in "List of faults and alarms (Page 693)".

Faults and alarms are organized into the following number ranges:

Table 4-5 Number ranges of faults and alarms

of	To	Area
1000	3999	Control Unit
4000	4999	Reserved
5000	5999	Power section
6000	6899	Infeed
6900	6999	Braking Module
7000	7999	Drive
8000	8999	Option Board
9000	12999	Reserved
13000	13033	Licensing
13034	13099	Reserved
13100	13102	Know-how protection
13103	19999	Reserved
20000	29999	OEM
30000	30999	DRIVE-CLiQ component power unit
31000	31999	DRIVE-CLiQ component encoder 1
32000	32999	DRIVE-CLiQ component encoder 2 Note Faults that occur are automatically output as an alarm if the encoder is parameterized as a direct measuring system and does not intervene in the motor control.
33000	33999	DRIVE-CLiQ component encoder 3 Note Faults that occur are automatically output as an alarm if the encoder is parameterized as a direct measuring system and does not intervene in the motor control.
34000	34999	Voltage Sensing Module (VSM)
35000	35199	Terminal Module 54F (TM54F)
35200	35999	Terminal Module 31 (TM31)
36000	36999	DRIVE-CLiQ Hub Module
37000	37999	HF Damping Module

4.1 Overview of faults and alarms

Table 4-5 Number ranges of faults and alarms, continued

of	To	Area
40000	40999	Controller Extension 32 (CX32)
41000	48999	Reserved
49000	49999	SINAMICS GM/SM/GL
50000	50499	Communication Board (COMM BOARD)
50500	59999	OEM Siemens
60000	65535	SINAMICS DC MASTER (closed-loop DC current control)

4.2 List of faults and alarms

Product: G115D, Version: 4715218, Language: eng
Objects: G115D ASI, G115D I/O, G115D PN

F01000	Internal software error
Message class:	Hardware/software error (1)
Reaction:	OFF2
Acknowledge:	POWER ON
Cause:	An internal software error has occurred. Fault value (r0949, interpret hexadecimal): Only for internal Siemens troubleshooting.
Remedy:	<ul style="list-style-type: none">- Evaluate fault buffer (r0945).- Carry out a POWER ON (switch-off/switch-on) for all components.- If required, check the data on the non-volatile memory (e.g. memory card).- Upgrade firmware to later version.- Contact Technical Support.- Replace the Control Unit.

F01001	FloatingPoint exception
Message class:	Hardware/software error (1)
Reaction:	OFF2
Acknowledge:	POWER ON
Cause:	An exception occurred for an operation with the FloatingPoint data type. The error may be caused by the basic system or an OA application (e.g. FBLOCKS, DCC). Fault value (r0949, interpret hexadecimal): Only for internal Siemens troubleshooting. Note: Refer to r9999 for further information about this fault. r9999[0]: Fault number. r9999[1]: Program counter at the time when the exception occurred. r9999[2]: Cause of the FloatingPoint exception. Bit 0 = 1: Operation invalid Bit 1 = 1: Division by zero Bit 2 = 1: Overflow Bit 3 = 1: Underflow Bit 4 = 1: Inaccurate result
Remedy:	<ul style="list-style-type: none">- Carry out a POWER ON (switch-off/switch-on) for all components.- Check configuration and signals of the blocks in FBLOCKS.- Check configuration and signals of DCC charts.- Upgrade firmware to later version.- Contact Technical Support.

F01002	Internal software error
Message class:	Hardware/software error (1)
Reaction:	OFF2
Acknowledge:	IMMEDIATELY
Cause:	An internal software error has occurred. Fault value (r0949, interpret hexadecimal): Only for internal Siemens troubleshooting.
Remedy:	<ul style="list-style-type: none">- Carry out a POWER ON (switch-off/switch-on) for all components.- Upgrade firmware to later version.- Contact Technical Support.

F01003	Acknowledgment delay when accessing the memory
Message class:	Hardware/software error (1)
Reaction:	OFF2
Acknowledge:	IMMEDIATELY
Cause:	A memory area was accessed that does not return a "READY". Fault value (r0949, interpret hexadecimal): Only for internal Siemens troubleshooting.
Remedy:	- Carry out a POWER ON (switch-off/switch-on) for all components. - Contact Technical Support.

N01004 (F, A)	Internal software error
Message class:	Hardware/software error (1)
Reaction:	NONE
Acknowledge:	NONE
Cause:	An internal software error has occurred. Fault value (r0949, hexadecimal): Only for internal Siemens troubleshooting.
Remedy:	- Read out diagnostics parameter (r9999). - Contact Technical Support. See also: r9999 (Software error internal supplementary diagnostics)

F01005	File upload/download error
Message class:	Hardware/software error (1)
Reaction:	NONE
Acknowledge:	IMMEDIATELY
Cause:	The upload or download of EEPROM data was unsuccessful. Fault value (r0949, interpret hexadecimal): yyxxx hex: yy = component number, xxx = fault cause xxx = 000B hex = 11 dec: Power unit component has detected a checksum error. xxx = 000F hex = 15 dec: The selected power unit will not accept the content of the EEPROM file. xxx = 0011 hex = 17 dec: Power unit component has detected an internal access error. xxx = 0012 hex = 18 dec: After several communication attempts, no response from the power unit component. xxx = 008B hex = 140 dec: EEPROM file for the power unit component not available on the memory card. xxx = 008D hex = 141 dec: An inconsistent length of the firmware file was signaled. It is possible that the download/upload has been interrupted. xxx = 0090 hex = 144 dec: When checking the file that was loaded, the component detected a fault (checksum). It is possible that the file on the memory card is defective. xxx = 0092 hex = 146 dec: This SW or HW does not support the selected function. xxx = 009C hex = 156 dec: Component with the specified component number is not available (p7828). xxx = Additional values: Only for internal Siemens troubleshooting.
Remedy:	Save a suitable firmware file or EEPROM file for upload or download in folder "/ee_sac/" on the memory card.

A01009 (N)	CU: Control module overtemperature
Message class:	Overtemperature of the electronic components (6)
Reaction:	NONE
Acknowledge:	NONE

Cause: The temperature (r0037[0]) of the control module (Control Unit) has exceeded the specified limit value.
Remedy: - check the air intake for the Control Unit.
- check the Control Unit fan.
Note:
The alarm is automatically withdrawn once the limit value has been fallen below.

F01010 Drive type unknown
Message class: Error in the parameterization / configuration / commissioning procedure (18)
Reaction: NONE
Acknowledge: IMMEDIATELY
Cause: An unknown drive type was found.
Remedy: - replace Power Module.
- carry out a POWER ON (switch-off/switch-on).
- upgrade firmware to later version.
- contact Technical Support.

F01015 Internal software error
Message class: Hardware/software error (1)
Reaction: OFF2
Acknowledge: POWER ON
Cause: An internal software error has occurred.
Fault value (r0949, interpret decimal):
Only for internal Siemens troubleshooting.
Remedy: - carry out a POWER ON (switch-off/switch-on) for all components.
- upgrade firmware to later version.
- contact Technical Support.

A01016 (F) Firmware changed
Message class: Hardware/software error (1)
Reaction: NONE
Acknowledge: NONE
Cause: At least one firmware file in the directory was illegally changed on the non-volatile memory (memory card/device memory) with respect to the version when shipped from the factory.
Alarm value (r2124, interpret decimal):
0: Checksum of one file is incorrect.
1: File missing.
2: Too many files.
3: Incorrect firmware version.
4: Incorrect checksum of the back-up file.
Remedy: For the non-volatile memory for the firmware (memory card/device memory), restore the delivery condition.
Note:
The file involved can be read out using parameter r9925.
The status of the firmware check is displayed using r9926.
See also: r9925 (Firmware file incorrect), r9926 (Firmware check status)

A01017 Component lists changed
Message class: Hardware/software error (1)
Reaction: NONE
Acknowledge: NONE

Cause:	On the memory card, one file in the directory /SIEMENS/SINAMICS/DATA or /ADDON/SINAMICS/DATA has been illegally changed with respect to that supplied from the factory. No changes are permitted in this directory. Alarm value (r2124, interpret decimal): zyx dec: x = Problem, y = Directory, z = File name x = 1: File does not exist. x = 2: Firmware version of the file does not match the software version. x = 3: File checksum is incorrect. y = 0: Directory /SIEMENS/SINAMICS/DATA/ y = 1: Directory /ADDON/SINAMICS/DATA/ z = 0: File MOTARM.ACX z = 1: File MOTSRM.ACX z = 2: File MOTSLM.ACX z = 3: File ENCDATA.ACX z = 4: File FILTDATA.ACX z = 5: File BRKDATA.ACX z = 6: File DAT_BEAR.ACX z = 7: File CFG_BEAR.ACX
Remedy:	For the file on the memory card involved, restore the status originally supplied from the factory.

F01018	Bootling has been interrupted several times
Message class:	Hardware/software error (1)
Reaction:	NONE
Acknowledge:	POWER ON
Cause:	Module bootling was interrupted several times. As a consequence, the module boots with the factory setting. Possible reasons for bootling being interrupted: - power supply interrupted. - CPU crashed. - parameterization invalid.
Remedy:	- carry out a POWER ON (switch-off/switch-on). After switching on, the module reboots from the valid parameterization (if available). - restore the valid parameterization. Examples: a) Carry out a first commissioning, save, carry out a POWER ON (switch-off/switch-on). b) Load another valid parameter backup (e.g. from the memory card), save, carry out a POWER ON (switch-off/switch-on). Note: If the fault situation is repeated, then this fault is again output after several interrupted boots.

A01019	Writing to the removable data medium unsuccessful
Message class:	Hardware/software error (1)
Reaction:	NONE
Acknowledge:	NONE
Cause:	The write access to the removable data medium was unsuccessful.
Remedy:	- Check the removable data medium and if required replace. - Disconnect any existing USB connection. - Repeat the data backup.

A01020	Writing to RAM disk unsuccessful
Message class:	Hardware/software error (1)
Reaction:	NONE
Acknowledge:	NONE
Cause:	A write access to the internal RAM disk was unsuccessful.
Remedy:	Adapt the file size for the system logbook to the internal RAM disk (p9930). See also: p9930 (System logbook activation)

A01021	Removable data medium as USB data storage medium from the PC used
Message class:	General drive fault (19)
Reaction:	NONE
Acknowledge:	NONE
Cause:	The removable data medium is used as USB data storage medium from a PC As a consequence, the drive cannot access the removable data medium. When backing up, the configuration data cannot be saved on the removable data medium. Alarm value (r2124, interpret decimal): 1: The know-how protection as well as the copy protection for the removable data medium is active. Backup is inhibited. 2: The configuration data are only backed up in the Control Unit. See also: r7760 (Write protection/know-how protection status), r9401 (Safely remove memory card status)
Remedy:	Deactivate the USB connection to the PC and back up the configuration data. Note: The alarm is automatically canceled when disconnecting the USB connection or when removing the removable data medium.

F01023	Software timeout (internal)
Message class:	Hardware/software error (1)
Reaction:	NONE
Acknowledge:	IMMEDIATELY
Cause:	An internal software timeout has occurred. Fault value (r0949, interpret decimal): Only for internal Siemens troubleshooting.
Remedy:	- carry out a POWER ON (switch-off/switch-on) for all components. - upgrade firmware to later version. - contact Technical Support.

A01028 (F)	Configuration error
Message class:	Error in the parameterization / configuration / commissioning procedure (18)
Reaction:	NONE
Acknowledge:	NONE
Cause:	The parameterization that was downloaded was generated with a different module type (Order No., MLFB).
Remedy:	Save parameters in a non-volatile fashion (p0971 = 1).

F01029	DIP switch and parameter inconsistent
Message class:	Error in the parameterization / configuration / commissioning procedure (18)
Reaction:	NONE
Acknowledge:	IMMEDIATELY
Cause:	Different settings between the parameters and the DIP switch were identified. Fault value (r0949, interpret decimal): 0: The setting for 87 Hz operation using DIP switch DIP1.6 is different for the configuration using parameter p0133.1. The setting of DIP switch DIP1.6 was transferred into p0133.1. 1: The setting for the motor type using DIP switch DIP1.5 differs from the configuration using parameter p0300/p0301. The setting of DIP switch DIP1.5 was transferred into p0300/p0301. See also: p0133 (Motor configuration), p0300 (Motor type selection), p0301 (Motor code number selection)
Remedy:	- If required, change the setting of DIP switch DIP1. - If required, save parameters in a non-volatile fashion (p0971 = 1).

F01030	Sign-of-life failure for master control
Message class:	Communication error to the higher-level control system (9)
Reaction:	OFF3 (IASC/DCBRK, NONE, OFF1, OFF2, STOP2)
Acknowledge:	IMMEDIATELY

Cause: For active PC master control, no sign-of-life was received within the monitoring time.
The master control was returned to the active BICO interconnection.

Remedy: Set the monitoring time higher at the PC or, if required, completely disable the monitoring function.
For the commissioning software, the monitoring time is set as follows:
<Drive> -> Commissioning -> Control panel -> Button "Fetch master control" -> A window is displayed to set the monitoring time in milliseconds.
Notice:
The monitoring time should be set as short as possible. A long monitoring time means a late response when the communication fails!

F01033 **Units changeover: Reference parameter value invalid**

Message class: Error in the parameterization / configuration / commissioning procedure (18)

Reaction: NONE

Acknowledge: IMMEDIATELY

Cause: When changing over the units to the referred representation type, it is not permissible for any of the required reference parameters to be equal to 0.0
Fault value (r0949, parameter):
Reference parameter whose value is 0.0.
See also: p0505 (Selecting the system of units), p0595 (Technological unit selection)

Remedy: Set the value of the reference parameter to a number different than 0.0.
See also: p0304, p0305, p0310, p0596, p2000, p2001, p2002, p2003, r2004

F01034 **Units changeover: Calculation parameter values after reference value change unsuccessful**

Message class: Error in the parameterization / configuration / commissioning procedure (18)

Reaction: NONE

Acknowledge: IMMEDIATELY

Cause: The change of a reference parameter meant that for an involved parameter the selected value was not able to be re-calculated in the per unit representation. The change was rejected and the original parameter value restored.
Fault value (r0949, parameter):
Parameter whose value was not able to be re-calculated.
See also: p0304, p0305, p0310, p0596, p2000, p2001, p2002, p2003, r2004

Remedy: - Select the value of the reference parameter such that the parameter involved can be calculated in the per unit representation.
- Technology unit selection (p0595) before changing the reference parameter p0596, set p0595 = 1.

A01035 (F) **ACX: Parameter back-up file corrupted**

Message class: Hardware/software error (1)

Reaction: NONE

Acknowledge: NONE

Cause: When the Control Unit is booted, no complete data set was found from the parameter back-up files. The last time that the parameterization was saved, it was not completely carried out.
It is possible that the backup was interrupted by switching off or withdrawing the memory card.
Alarm value (r2124, interpret hexadecimal):
ddccbbaa hex:
aa = 01 hex:
Power up was realized without data backup. The drive is in the factory setting.
aa = 02 hex:
The last available internal backup data record was loaded. The parameterization must be checked. It is recommended that the parameterization is downloaded again.
aa = 03 hex:
The last available data record from the memory card was loaded. The parameterization must be checked.
aa = 04 hex:
An invalid data backup was loaded from the memory card into the drive. The drive is in the factory setting.
dd, cc, bb:
Only for internal Siemens troubleshooting.
See also: p0971 (Save parameters)

Remedy:

- Download the project again with the commissioning software.
- Save all parameters (p0971 = 1 or "copy RAM to ROM").

F01036 (A) ACX: Parameter back-up file missing

Message class: Hardware/software error (1)

Reaction: NONE (OFF1, OFF2, OFF3)

Acknowledge: IMMEDIATELY

Cause: When downloading the device parameterization, a parameter back-up file PSxxxxxyy.ACX associated with a drive object cannot be found.

Fault value (r0949, interpret hexadecimal):

Byte 1: yyy in the file name PSxxxxxyy.ACX

yyy = 000 --> consistency back-up file

yyy = 001 ... 062 --> drive object number

yyy = 099 --> PROFIBUS parameter back-up file

Byte 2, 3, 4:

Only for internal Siemens troubleshooting.

Remedy: If you have saved the project data using the commissioning software, carry out a new download for your project.

Save using the function "Copy RAM to ROM" or with p0971 = 1.

This means that the parameter files are again completely written into the non-volatile memory.

Note:

If the project data have not been backed up, then a new first commissioning is required.

F01038 (A) ACX: Loading the parameter back-up file unsuccessful

Message class: Hardware/software error (1)

Reaction: NONE (OFF1, OFF2, OFF3)

Acknowledge: IMMEDIATELY

Cause: An error has occurred when downloading PSxxxxxyy.ACX or PTxxxxxyy.ACX files from the non-volatile memory.

Fault value (r0949, interpret hexadecimal):

Byte 1: yyy in the file name PSxxxxxyy.ACX

yyy = 000 --> consistency back-up file

yyy = 001 ... 062 --> drive object number

yyy = 099 --> PROFIBUS parameter back-up file

Byte 2:

255: Incorrect drive object type.

254: Topology comparison unsuccessful -> drive object type was not able to be identified.

Reasons could be:

- Incorrect component type in the actual topology
- Component does not exist in the actual topology.
- Component not active.

Additional values:

Only for internal Siemens troubleshooting.

Byte 4, 3:

Only for internal Siemens troubleshooting.

Remedy:

- If you have saved the project data using the commissioning software, download the project again. Save using the function "Copy RAM to ROM" or with p0971 = 1. This means that the parameter files are again completely written to the non-volatile memory.

- Replace the memory card or Control Unit.

F01039 (A) ACX: Writing to the parameter back-up file was unsuccessful

Message class: Hardware/software error (1)

Reaction: NONE (OFF1, OFF2, OFF3)

Acknowledge: IMMEDIATELY

4 Faults and alarms

4.2 List of faults and alarms

Cause:	<p>Writing to at least one parameter back-up file PSxxxxyy.*** in the non-volatile memory was unsuccessful.</p> <ul style="list-style-type: none">- in the directory /USER/SINAMICS/DATA/ at least one parameter back-up file PSxxxxyy.*** has the "read only" file attribute and cannot be overwritten.- there is not sufficient free memory space available.- the non-volatile memory is defective and cannot be written to. <p>Fault value (r0949, interpret hexadecimal): dcba hex</p> <p>a = yyy in the file names PSxxxxyy.*** a = 000 --> consistency back-up file a = 001 ... 062 --> drive object number a = 099 --> PROFIBUS parameter back-up file</p> <p>b = xxx in the file names PSxxxxyy.*** b = 000 --> data save started with p0971 = 1 b = 010 --> data save started with p0971 = 10 b = 011 --> data save started with p0971 = 11 b = 012 --> data save started with p0971 = 12</p> <p>d, c: Only for internal Siemens troubleshooting.</p>
Remedy:	<ul style="list-style-type: none">- check the file attribute of the files (PSxxxxyy.***, CAxxxxyy.***, CCxxxxyy.***) and, if required, change from "read only" to "writeable".- check the free memory space in the non-volatile memory. Approx. 80 kbyte of free memory space is required for every drive object in the system.- replace the memory card or Control Unit.

F01040 Save parameter settings and carry out a POWER ON

Message class:	Error in the parameterization / configuration / commissioning procedure (18)
Reaction:	OFF2
Acknowledge:	POWER ON
Cause:	A parameter has been changed that requires the parameters to be backed up and the Control Unit to be switched OFF and ON again.
Remedy:	<ul style="list-style-type: none">- Save parameters (p0971).- carry out a POWER ON (switch-off/switch-on) for the Control Unit.

F01042 Parameter error during project download

Message class:	Error in the parameterization / configuration / commissioning procedure (18)
Reaction:	OFF2 (NONE, OFF1, OFF3)
Acknowledge:	IMMEDIATELY

Cause:	<p>An error was detected when downloading a project using the commissioning software (e.g. incorrect parameter value).</p> <p>For the specified parameter, it was detected that dynamic limits were exceeded that may possibly depend on other parameters.</p> <p>Fault value (r0949, interpret hexadecimal): cbbaaaa hex aaaa = Parameter bb = Index cc = fault cause</p> <p>0: Parameter number illegal. 1: Parameter value cannot be changed. 2: Lower or upper value limit exceeded. 3: Sub-index incorrect. 4: No array, no sub-index. 5: Data type incorrect. 6: Setting not permitted (only resetting). 7: Descriptive element cannot be changed. 9: Descriptive data not available. 11: No master control. 15: No text array available. 17: Task cannot be executed due to operating state. 20: Illegal value. 21: Response too long. 22: Parameter address illegal. 23: Format illegal. 24: Number of values not consistent. 108: Unit unknown.</p> <p>Additional values: Only for internal Siemens troubleshooting.</p>
Remedy:	<ul style="list-style-type: none"> - enter the correct value in the specified parameter. - identify the parameter that restricts the limits of the specified parameter.

F01043**Fatal error at project download**

Message class:	Error in the parameterization / configuration / commissioning procedure (18)
Reaction:	OFF2 (OFF1, OFF3)
Acknowledge:	IMMEDIATELY
Cause:	<p>A fatal error was detected when downloading a project using the commissioning software.</p> <p>Fault value (r0949, interpret decimal):</p> <p>1: Device status cannot be changed to Device Download (drive object ON?). 2: Incorrect drive object number. 8: Maximum number of drive objects that can be generated exceeded. 11: Error while generating a drive object (global component). 12: Error while generating a drive object (drive component). 13: Unknown drive object type. 14: Drive status cannot be changed to "ready for operation" (r0947 and r0949). 15: Drive status cannot be changed to drive download. 16: Device status cannot be changed to "ready for operation". 18: A new download is only possible if the factory settings are restored for the drive unit. 20: The configuration is inconsistent. 21: Error when accepting the download parameters. 22: SW-internal download error. 100: The download was canceled, because no write requests were received from the commissioning client (e.g. for communication error).</p> <p>Additional values: Only for internal Siemens troubleshooting.</p>

4 Faults and alarms

4.2 List of faults and alarms

- Remedy:**
- use the current version of the commissioning software.
 - modify the offline project and download again (e.g. compare the motor and Power Module in the offline project and on the drive).
 - change the drive state (is a drive rotating or is there a message/signal?).
 - carefully note any other messages/signals and remove their cause.
 - boot from previously saved files (switch-off/switch-on or p0970).

F01044 CU: Descriptive data error

Message class: Hardware/software error (1)
Reaction: OFF2
Acknowledge: POWER ON
Cause: An error was detected when loading the descriptive data saved in the non-volatile memory.
Remedy: Replace the memory card or Control Unit.

A01045 Configuring data invalid

Message class: Hardware/software error (1)
Reaction: NONE
Acknowledge: NONE
Cause: An error was detected when evaluating the parameter files PSxxxxxy.ACX, PTxxxxxy.ACX, CAxxxxxy.ACX, or CCxxxxxy.ACX saved in the non-volatile memory. Because of this, under certain circumstances, several of the saved parameter values were not able to be accepted. Also see r9406 up to r9408.
Alarm value (r2124, interpret hexadecimal):
Only for internal Siemens troubleshooting.

Remedy:

- Check the parameters displayed in r9406 up to r9408, and correct these if required.
- Restore the factory setting using (p0970 = 1) and re-load the project into the drive unit.

Then save the parameterization in STARTER using the function "Copy RAM to ROM" or with p0971 = 1. This overwrites the incorrect parameter files in the non-volatile memory – and the alarm is withdrawn.

See also: r9406 (PS file parameter number parameter not transferred), r9407 (PS file parameter index parameter not transferred), r9408 (PS file fault code parameter not transferred)

A01049 It is not possible to write to file

Message class: Hardware/software error (1)
Reaction: NONE
Acknowledge: NONE
Cause: It is not possible to write into a write-protected file (PSxxxxxx.acx). The write request was interrupted.
Alarm value (r2124, interpret decimal):
Drive object number.

Remedy: Check whether the "write protected" attribute has been set for the files in the non-volatile memory under .../USER/SINAMICS/DATA/... When required, remove write protection and save again (e.g. set p0971 to 1).

F01054 CU: System limit exceeded

Message class: Error in the parameterization / configuration / commissioning procedure (18)
Reaction: OFF2
Acknowledge: IMMEDIATELY
Cause: At least one system overload has been identified.
Fault value (r0949, interpret decimal):
1: Computing time load too high (r9976[1]).
5: Peak load too high (r9976[5]).
Note:
As long as this fault is present, it is not possible to save the parameters (p0971).
See also: r9976 (System utilization)

Remedy: For fault value = 1, 5:

- reduce the computing time load of the drive unit (r9976[1] and r9976[5]) to under 100 %.
- check the sampling times and adjust if necessary (p0115, p0799, p4099).
- deactivate function modules.
- deactivate drive objects.
- remove drive objects from the target topology.
- note the DRIVE-CLiQ topology rules and if required, change the DRIVE-CLiQ topology.

When using the Drive Control Chart (DCC) or free function blocks (FBLOCKS), the following applies:

- the computing time load of the individual runtime groups on a drive object can be read out in r21005 (DCC) or r20005 (FBLOCKS).
- if necessary, the assignment of the runtime group (p21000, p20000) can be changed in order to increase the sampling time (r21001, r20001).
- if necessary, reduce the number of cyclically calculated blocks (DCC) and/or function blocks (FBLOCKS).

A01064 (F) CU: Internal error (CRC)

Message class: Hardware/software error (1)

Reaction: NONE

Acknowledge: NONE

Cause: A checksum error (CRC error) has occurred in the Control Unit program memory

Remedy:

- carry out a POWER ON (switch-off/switch-on) for all components.
- upgrade firmware to later version.
- contact Technical Support.

A01066 Buffer memory: 70% fill level reached or exceeded

Message class: General drive fault (19)

Reaction: NONE

Acknowledge: NONE

Cause: The non-volatile buffer memory for parameter changes is filled to at least 70%.
This can also occur if the buffer memory is active (p0014 = 1) and parameters are continually changed via a fieldbus system.

Remedy: If required, deactivate and clear the buffer memory (p0014 = 0).
If required, clear the buffer memory (p0014 = 2).
In the following cases, the entries in the buffer memory are transferred into the ROM and then the buffer memory is cleared:

- p0971 = 1
- switch-off/switch-on Control Unit

A01067 Buffer memory: 100 % fill level reached

Message class: General drive fault (19)

Reaction: NONE

Acknowledge: NONE

Cause: The non-volatile buffer memory for parameter changes is filled to 100%.
All additional parameter changes will no longer be taken into account in the non-volatile buffer memory. However, parameter changes can still be made in the volatile memory (RAM).
This can also occur if the buffer memory is active (p0014 = 1) and parameters are continually changed via a fieldbus system.

Remedy: If required, deactivate and clear the buffer memory (p0014 = 0).
If required, clear the buffer memory (p0014 = 2).
In the following cases, the entries in the buffer memory are transferred into the ROM and then the buffer memory is cleared:

- p0971 = 1
- switch-off/switch-on Control Unit

F01068 CU: Data memory memory overflow

Message class: Error in the parameterization / configuration / commissioning procedure (18)

Reaction: OFF2

Acknowledge: IMMEDIATELY

4 Faults and alarms

4.2 List of faults and alarms

Cause: The utilization for a data memory area is too large.

Fault value (r0949, interpret binary):

Bit 0 = 1: High-speed data memory 1 overloaded

Bit 1 = 1: High-speed data memory 2 overloaded

Bit 2 = 1: High-speed data memory 3 overloaded

Bit 3 = 1: High-speed data memory 4 overloaded

Remedy:

- deactivate the function module.

- deactivate drive object.

- remove the drive object from the target topology.

A01069 Parameter backup and device incompatible

Message class: Error in the parameterization / configuration / commissioning procedure (18)

Reaction: NONE

Acknowledge: NONE

Cause: The parameter backup on the memory card and the drive unit do not match.

The module boots with the factory settings.

Example:

Devices A and B. are not compatible and a memory card with the parameter backup for device A is inserted in device B.

Remedy:

- insert a memory card with compatible parameter backup and carry out a POWER ON.

- insert a memory card without parameter backup and carry out a POWER ON.

- if required, withdraw the memory card and carry out POWER ON.

- save the parameters (p0971 = 1).

F01072 Memory card restored from the backup copy

Message class: General drive fault (19)

Reaction: NONE

Acknowledge: IMMEDIATELY

Cause: The Control Unit was switched-off while writing to the memory card. This is why the visible partition became defective.

After switching on, the data from the non-visible partition (backup copy) were written to the visible partition.

Remedy:

Check that the firmware and parameterization is up-to-date.

A01073 (N) POWER ON required for backup copy on memory card

Message class: General drive fault (19)

Reaction: NONE

Acknowledge: NONE

Cause: The parameter assignment on the visible partition of the memory card has changed.

In order that the backup copy on the memory card is updated on the non-visible partition, it is necessary to carry out a POWER ON or hardware reset (p0972) of the Control Unit.

Note:

It is possible that a new POWER ON is requested via this alarm (e.g. after saving with p0971 = 1).

Remedy:

- carry out a POWER ON (power off/on) for the Control Unit.

- carry out a hardware reset (RESET button, p0972).

N01101 (A) CU: memory card not available

Message class: Hardware/software error (1)

Reaction: NONE

Acknowledge: NONE

Cause: The memory card is not available for the drive.

Remedy:

Insert a memory card.

If Starter is not active, interrupt the USB connection to the PC

F01105 (A)	CU: Insufficient memory
Message class:	Error in the parameterization / configuration / commissioning procedure (18)
Reaction:	OFF1
Acknowledge:	POWER ON
Cause:	Too many data sets are configured on this Control Unit. Fault value (r0949, interpret decimal): Only for internal Siemens troubleshooting.
Remedy:	- reduce the number of data sets.

F01107	Save to memory card unsuccessful
Message class:	Hardware/software error (1)
Reaction:	NONE
Acknowledge:	IMMEDIATELY
Cause:	A data save to the memory card was not able to be successfully carried out. - Memory card is defective. - Insufficient space on memory card. Fault value (r0949, interpret decimal): 1: The file on the RAM was not able to be opened. 2: The file on the RAM was not able to be read. 3: A new directory could not be created on the memory card. 4: A new file could not be created on the memory card. 5: A new file could not be written on the memory card.
Remedy:	- Try to save again. - Replace the memory card or Control Unit.

F01112	CU: Power unit not permissible
Message class:	Error in the parameterization / configuration / commissioning procedure (18)
Reaction:	NONE
Acknowledge:	IMMEDIATELY
Cause:	The connected power unit cannot be used together with this Control Unit. Fault value (r0949, interpret decimal): 1: Power unit is not supported (e.g. PM340).
Remedy:	Replace the power unit that is not permissible by a component that is permissible.

F01120 (A)	Terminal initialization has failed
Message class:	Hardware/software error (1)
Reaction:	OFF1 (OFF2)
Acknowledge:	IMMEDIATELY (POWER ON)
Cause:	An internal software error occurred while the terminal functions were being initialized. Fault value (r0949, interpret hexadecimal): Only for internal Siemens troubleshooting.
Remedy:	- carry out a POWER ON (switch-off/switch-on) for all components. - upgrade firmware to later version. - contact Technical Support. - replace the Control Unit.

F01122 (A)	Frequency at the measuring probe input too high
Message class:	Application/technological function faulted (17)
Reaction:	OFF1 (OFF2)
Acknowledge:	IMMEDIATELY
Cause:	The frequency of the pulses at the measuring probe input is too high. Fault value (r0949, interpret decimal): 1: DI 1 (term. 6) 2: DI 3 (term. 8)
Remedy:	Reduce the frequency of the pulses at the measuring probe input.

F01152 **CU: Invalid constellation of drive object types**
Message class: Error in the parameterization / configuration / commissioning procedure (18)
Reaction: NONE
Acknowledge: POWER ON
Cause: It is not possible to simultaneously operate drive object types SERVO, VECTOR and HLA.
A maximum of 2 of these drive object types can be operated on a Control Unit.
Remedy:
- switch off the unit.
- restrict the use of drive object types SERVO, VECTOR, HLA to a maximum of 2.
- re-commission the unit.

F01205 **CU: Time slice overflow**
Message class: Hardware/software error (1)
Reaction: OFF2
Acknowledge: POWER ON
Cause: Insufficient computation time.
Fault value (r0949, interpret hexadecimal):
Only for internal Siemens troubleshooting.
Remedy: Contact Technical Support.

F01250 **CU: CU-EEPROM incorrect read-only data**
Message class: Hardware/software error (1)
Reaction: NONE (OFF2)
Acknowledge: POWER ON
Cause: Error when reading the read-only data of the EEPROM in the Control Unit.
Fault value (r0949, interpret decimal):
Only for internal Siemens troubleshooting.
Remedy:
- carry out a POWER ON.
- replace the Control Unit.

A01251 **CU: CU-EEPROM incorrect read-write data**
Message class: Hardware/software error (1)
Reaction: NONE
Acknowledge: NONE
Cause: Error when reading the read-write data of the EEPROM in the Control Unit.
Alarm value (r2124, interpret decimal):
Only for internal Siemens troubleshooting.
Remedy: For alarm value r2124 < 256, the following applies:
- carry out a POWER ON.
- replace the Control Unit.
For alarm value r2124 >= 256, the following applies:
- clear the fault memory (p0952 = 0).
- replace the Control Unit.

F01257 **CU: Firmware version out of date**
Message class: Error in the parameterization / configuration / commissioning procedure (18)
Reaction: OFF2
Acknowledge: POWER ON

Cause: The Control Unit firmware is too old.
Fault value (r0949, interpret hexadecimal):
bbbbbbba hex: aa = unsupported component
aa = 01 hex = 1 dec:
The firmware being used does not support the Control Unit.
aa = 02 hex = 2 dec:
The firmware being used does not support the Control Unit.
aa = 03 hex = 3 dec:
The firmware being used does not support the Power Module.
aa = 04 hex = 4 dec:
The firmware being used does not support the Control Unit.

Remedy: For fault value = 1, 2, 4:
- Upgrade the firmware of the Control Unit.
For fault value = 3:
- Upgrade the firmware of the Control Unit.
- Replace the Power Module by a component that is supported.

F01340 **Topology: Too many components on one line**

Message class: Error in the parameterization / configuration / commissioning procedure (18)

Reaction: NONE

Acknowledge: IMMEDIATELY

Cause: For the selected communications clock cycle, too many DRIVE-CLiQ components are connected to one line of the Control Unit.
Fault value (r0949, interpret hexadecimal):
xyy hex: x = fault cause, yy = component number or connection number.
1yy:
The communications clock cycle of the DRIVE-CLiQ connection on the Control Unit is not sufficient for all read transfers.
2yy:
The communications clock cycle of the DRIVE-CLiQ connection on the Control Unit is not sufficient for all write transfers.
3yy:
Cyclic communication is fully utilized.
4yy:
The DRIVE-CLiQ cycle starts before the earliest end of the application. An additional dead time must be added to the control. Sign-of-life errors can be expected.
The conditions of operation with a current controller sampling time of 31.25 µs have not been maintained.
5yy:
Internal buffer overflow for net data of a DRIVE-CLiQ connection.
6yy:
Internal buffer overflow for receive data of a DRIVE-CLiQ connection.
7yy:
Internal buffer overflow for send data of a DRIVE-CLiQ connection.
8yy:
The component clock cycles cannot be combined with one another
900:
The lowest common multiple of the clock cycles in the system is too high to be determined.
901:
The lowest common multiple of the clock cycles in the system cannot be generated with the hardware.

4 Faults and alarms

4.2 List of faults and alarms

- Remedy:**
- check the DRIVE-CLiQ wiring.
 - reduce the number of components on the DRIVE-CLiQ line involved and distribute these to other DRIVE-CLiQ sockets of the Control Unit. This means that communication is uniformly distributed over several lines.
- For fault value = 1yy - 4yy in addition:
- increase the sampling times (p0112, p0115, p4099). If necessary, for DCC or FBLOCKS, change the assignment of the runtime group (p21000, p20000) so that the sampling time (r21001, r20001) is increased.
 - if necessary, reduce the number of cyclically calculated blocks (DCC) and/or function blocks (FBLOCKS).
 - reduce the function modules (r0108).
 - establish the conditions for operation with a current controller sampling time of 31.25 µs (at the DRIVE-CLiQ line, only operate Motor Modules and Sensor Modules with this sampling time and only use a permitted Sensor Module (e.g. SMC20, this means a 3 at the last position of the order number)).
 - For an NX, the corresponding Sensor Module for a possibly existing second measuring system should be connected to a free DRIVE-CLiQ socket of the NX.
- For fault value = 8yy in addition:
- check the clock cycles settings (p0112, p0115, p4099). Clock cycles on a DRIVE-CLiQ line must be perfect integer multiples of one another. As clock cycle on a line, all clock cycles of all drive objects in the previously mentioned parameters apply, which have components on the line involved.
- For fault value = 9yy in addition:
- check the clock cycles settings (p0112, p0115, p4099). The lower the numerical value difference between two clock cycles, the higher the lowest common multiple. This behavior has a significantly stronger influence, the higher the numerical values of the clock cycles.

F01505 (A) BICO: Interconnection cannot be established

Message class: Error in the parameterization / configuration / commissioning procedure (18)

Reaction: NONE

Acknowledge: IMMEDIATELY

Cause: A PROFIdrive telegram has been set (p0922).
An interconnection contained in the telegram was not able to be established.
Fault value (r0949, interpret decimal):
Parameter receiver that should be changed.

Remedy: Establish another interconnection.

F01510 BICO: Signal source is not float type

Message class: Error in the parameterization / configuration / commissioning procedure (18)

Reaction: NONE

Acknowledge: IMMEDIATELY

Cause: The requested connector output does not have the correct data type. This interconnection is not established.
Fault value (r0949, interpret decimal):
Parameter number to which an interconnection should be made (connector output).

Remedy: Interconnect this connector input with a connector output having a float data type.

F01511 (A) BICO: Interconnection with different scalings

Message class: Error in the parameterization / configuration / commissioning procedure (18)

Reaction: NONE

Acknowledge: IMMEDIATELY

Cause: The requested BICO interconnection was established. However, a conversion is made between the BICO output and BICO input using the reference values.

- the BICO output has different normalized units than the BICO input.
- message only for interconnections within a drive object.

Example:
The BICO output has, as normalized unit, voltage and the BICO input has current.
This means that the factor p2002/p2001 is calculated between the BICO output and the BICO input.
p2002: contains the reference value for current
p2001: contains the reference value for voltage
Fault value (r0949, interpret decimal):
Parameter number of the BICO input (signal sink).

Remedy: Not necessary.

F01512	BICO: No scaling available
Message class:	Error in the parameterization / configuration / commissioning procedure (18)
Reaction:	OFF2
Acknowledge:	POWER ON
Cause:	An attempt was made to determine a conversion factor for a scaling that does not exist. Fault value (r0949, interpret decimal): Unit (e.g. corresponding to SPEED) for which an attempt was made to determine a factor.
Remedy:	Apply scaling or check the transfer value.
F01513 (N, A)	BICO: Interconnection cross DO with different scalings
Message class:	Error in the parameterization / configuration / commissioning procedure (18)
Reaction:	NONE
Acknowledge:	IMMEDIATELY
Cause:	The requested BICO interconnection was established. However, a conversion is made between the BICO output and BICO input using the reference values. An interconnection is made between different drive objects and the BICO output has different normalized units than the BICO input or the normalized units are the same but the reference values are different. Example 1: BICO output with voltage normalized unit, BICO input with current normalized unit, BICO output and BICO input lie in different drive objects. This means that the factor $p2002/p2001$ is calculated between the BICO output and the BICO input. p2002: contains the reference value for current p2001: contains the reference value for voltage Example 2: BICO output with voltage normalized unit in drive object 1 (DO1), BICO input with voltage normalized unit in drive object 2 (DO2). The reference values for voltage (p2001) of the two drive objects have different values. This means that the factor $p2001(DO1)/p2001(DO2)$ is calculated between the BICO output and the BICO input. p2001: contains the reference value for voltage, drive objects 1, 2 Fault value (r0949, interpret decimal): Parameter number of the BICO input (signal sink).
Remedy:	Not necessary.
A01514 (F)	BICO: Error when writing during a reconnect
Message class:	Error in the parameterization / configuration / commissioning procedure (18)
Reaction:	NONE
Acknowledge:	NONE
Cause:	During a reconnect operation (e.g. while booting or downloading - but can also occur in normal operation) a parameter was not able to be written to. Example: When writing to BICO input with double word format (DWORD), in the second index, the memory areas overlap (e.g. p8861). The parameter is then reset to the factory setting. Alarm value (r2124, interpret decimal): Parameter number of the BICO input (signal sink).
Remedy:	Not necessary.
F01515 (A)	BICO: Writing to parameter not permitted as the master control is active
Message class:	Error in the parameterization / configuration / commissioning procedure (18)
Reaction:	NONE
Acknowledge:	IMMEDIATELY
Cause:	When changing the number of CDS or when copying from CDS, the master control is active.
Remedy:	If required, return the master control and repeat the operation.
A01590 (F)	Drive: Motor maintenance interval expired
Message class:	General drive fault (19)
Reaction:	NONE
Acknowledge:	NONE

4 Faults and alarms

4.2 List of faults and alarms

Cause: The selected service/maintenance interval for this motor was reached.
Alarm value (r2124, interpret decimal):
Motor data set number.
See also: p0650 (Actual motor operating hours), p0651 (Motor operating hours maintenance interval)

Remedy: carry out service/maintenance and reset the service/maintenance interval (p0651).

F01600 **SI P1 (CU): STOP A initiated**

Message class: Safety monitoring channel has identified an error (10)

Reaction: OFF2

Acknowledge: IMMEDIATELY (POWER ON)

Cause: The drive-integrated "Safety Integrated" function on processor 1 has detected an error and initiated a STOP A.
- forced checking procedure (test stop) of the safety switch-off signal path on processor 1 unsuccessful.
- subsequent response to fault F01611 (defect in a monitoring channel).
Fault value (r0949, interpret decimal):
0: Stop request from processor 2.
1005: Pulses suppressed although STO not selected and there is no internal STOP A present.
1010: Pulses enabled although STO is selected or an internal STOP A is present.
1011: Internal fault for the pulse enable in the Power Module.
9999: Subsequent response to fault F01611.

Remedy: - select Safe Torque Off and de-select again.
- carry out a POWER ON (switch-off/switch-on) for all components.
- replace Power Module involved.
For fault value = 9999:
- carry out diagnostics for fault F01611.

Note:
PM: Power Module
STO: Safe Torque Off

F01611 (A) **SI P1 (CU): Defect in a monitoring channel**

Message class: Safety monitoring channel has identified an error (10)

Reaction: NONE (OFF1, OFF2, OFF3)

Acknowledge: IMMEDIATELY (POWER ON)

Cause: The drive-integrated "Safety Integrated" function on processor 1 has detected a fault in the data cross-check between the two monitoring channels and has initiated a STOP F.
 Fault F01600 (SI P1: STOP A initiated) is output as a consequence of this fault.
 Fault value (r0949, interpret decimal):
 0: Stop request from the other monitoring channel.
 1 ... 999:
 Number of the cross-compared data that resulted in this fault. This number is also displayed in r9795.
 2: SI enable safety functions (p9601, p9801). Crosswise data comparison is only carried out for the supported bits.
 3: SI F-DI changeover discrepancy time (p9650, p9850).
 8: SI PROFIsafe address (p9610, p9810).
 9: SI debounce time for STO (p9651, p9851).
 1000: Watchdog timer has expired.
 Within the time of approx. 5 x p9650, alternatively, the following was defined:
 - the signal at F-DI continually changed with time intervals less than or equal to the discrepancy time (p9650/p9850).
 - via PROFIsafe, STO (also as subsequent response) was continually selected and deselected with time intervals less than or equal to the discrepancy time (p9650/p9850).
 1001, 1002: Initialization error, change timer / check timer.
 1950: Module temperature outside the permissible temperature range.
 1951: Module temperature not plausible.
 2000: Status of the STO selection for both monitoring channels different.
 2001: Feedback signal of safe pulse cancellation for both monitoring channels different.
 2003: Status of the STO terminal for both monitoring channels are different.
 6000 ... 6166:
 PROFIsafe fault values (PROFIsafe driver for PROFIBUS DP V1/V2 and PROFINET).
 For these fault values, the failsafe control signals (failsafe values) are transferred to the safety functions.
 6000: An internal software error has occurred (only for internal Siemens troubleshooting).
 6064 ... 6071: error when evaluating the F parameter. The values of the transferred F parameters do not match the expected values in the PROFIsafe driver.
 6064: Destination address and PROFIsafe address are different (F_Dest_Add).
 6065: Destination address not valid (F_Dest_Add).
 6066: Source address not valid (F_Source_Add).
 6067: Watchdog time not valid (F_WD_Time).
 6068: Incorrect SIL level (F_SIL).
 6069: Incorrect F-CRC length (F_CRC_Length).
 6070: Incorrect F parameter version (F_Par_Version).
 6071: CRC error for the F parameters (CRC1). The transferred CRC value of the F parameters does not match the value calculated in the PROFIsafe driver.
 6072: F parameterization is inconsistent.
 6165: A communications error was identified when receiving the PROFIsafe telegram. The fault may also occur if an inconsistent or out-of-date PROFIsafe telegram has been received after switching the Control Unit off and on or after plugging in the PROFIBUS/PROFINET cable.
 6166: A time monitoring error (timeout) was identified when receiving the PROFIsafe telegram.

- Remedy:**
- For fault values 1 ... 999 described in "Cause":
- check the cross data comparison that resulted in a STOP F.
 - carry out a POWER ON (switch-off/switch-on).
- For fault value = 1000:
- check the wiring of the F-DI (contact problems).
 - PROFIsafe: Remove contact problems/faults at the PROFIBUS master/PROFINET controller.
 - check the discrepancy time, and if required, increase the value (p9650/p9850).
- For fault value = 1001, 1002:
- carry out a POWER ON (switch-off/switch-on).
- For fault value = 1950, 1951:
- Operate the Control Unit in the permissible temperature range.
 - replace Control Unit.
- For fault value = 2000, 2001, 2003:
- check the discrepancy time, and if required, increase the value (p9650/p9850).
 - check the wiring of the F-DI (contact problems).
 - check the causes of the STO selection in r9772.
- For fault value = 6000:
- carry out a POWER ON (switch-off/switch-on).
 - upgrade firmware to later version.
 - contact Technical Support.
 - replace Control Unit.
- For fault value = 6064:
- check the setting of the value in the F parameter F_Dest_Add at the PROFIsafe slave.
 - check the setting of the PROFIsafe address on processor 1 (p9610) and on processor 2 (p9810).
- For fault value = 6065:
- check the setting of the value in the F parameter F_Dest_Add at the PROFIsafe slave. It is not permissible for the destination address to be either 0 or FFFF!
- For fault value = 6066:
- check the setting of the value in the F parameter F_Source_Add at the PROFIsafe slave. It is not permissible for the source address to be either 0 or FFFF!
- For fault value = 6067:
- check the setting of the value in the F parameter F_WD_Time at the PROFIsafe slave. It is not permissible for the watch time to be 0!
- For fault value = 6068:
- check the setting of the value in the F parameter F_SIL at the PROFIsafe slave. The SIL level must correspond to SIL2!
- For fault value = 6069:
- check the setting of the value in the F parameter F_CRC_Length at the PROFIsafe slave. The setting of the CRC2 length is 2-byte CRC in the V1 mode and 3-byte CRC in the V2 mode!
- For fault value = 6070:
- check the setting of the value in the F parameter F_Par_Version at the PROFIsafe slave. The value for the F parameter version is 0 in the V1 mode and 1 in the V2 mode!
- For fault value = 6071:
- check the settings of the values of the F parameters and the F parameter CRC (CRC1) calculated from these at the PROFIsafe slave and, if required, update.
- For fault value = 6072:
- check the settings of the values for the F parameters and, if required, correct.
- The following combinations are permissible for F parameters F_CRC_Length and F_Par_Version:
- F_CRC_Length = 2-byte CRC and F_Par_Version = 0
- F_CRC_Length = 3-byte CRC and F_Par_Version = 1
- For fault value = 6165:
- if the fault occurs after powering up or after inserting the PROFIBUS/PROFINET cable, acknowledge the fault.
 - check the configuration and communication at the PROFIsafe slave.
 - check the setting of the value for F parameter F_WD_Time on the PROFIsafe slave and increase if necessary.
 - check whether all F parameters of the drive match the F parameters of the F host.
- For fault value = 6166:
- check the configuration and communication at the PROFIsafe slave.

- check the setting of the value for F parameter F_WD_Time on the PROFIsafe slave and increase if necessary.
- evaluate diagnostic information in the F host.
- check PROFIsafe connection.
- check whether all F parameters of the drive match the F parameters of the F host.

For fault values that are described in "Cause":

- carry out a POWER ON (switch-off/switch-on).
- contact Technical Support.
- replace Control Unit.

Note:

F-DI: Failsafe Digital Input

STO: Safe Torque Off

N01620 (F, A)

SI P1 (CU): Safe Torque Off active

Message class: Safety monitoring channel has identified an error (10)

Reaction: NONE

Acknowledge: NONE

Cause: The "Safe Torque Off" (STO) function has been selected on processor 1 using the input terminal and is active.

Note:

This message does not result in a safety stop response.

Remedy: Not necessary.

Note:

STO: Safe Torque Off

F01625

SI P1 (CU): Sign-of-life error in safety data

Message class: Internal (DRIVE-CLiQ) communication error (12)

Reaction: OFF2

Acknowledge: IMMEDIATELY (POWER ON)

Cause: The drive-integrated "Safety Integrated" function on processor 1 has detected an error in the sign-of-life of the safety data and initiated a STOP A.

- there is a communication error between processor 1 and processor 2 or communication has failed.
- a time slice overflow of the safety software has occurred.

Fault value (r0949, interpret decimal):

Only for internal Siemens troubleshooting.

Remedy:

- select Safe Torque Off and de-select again.
- carry out a POWER ON (switch-off/switch-on).
- check whether additional faults are present and if required, perform diagnostics.
- check the electrical cabinet design and cable routing for EMC compliance
- check whether an impermissible voltage is connected at one of the digital outputs.
- check whether a digital output is loaded with an impermissible current.

F01640

SI P1 (CU): component replacement identified and acknowledgment/save required

Message class: General drive fault (19)

Reaction: NONE

Acknowledge: IMMEDIATELY

Cause:	<p>The "Safety Integrated" function integrated in the drive has identified that a component has been replaced. It is no longer possible to operate the drive. When safety functions are active, after a component has been replaced it is necessary to carry out a partial acceptance test. Fault value (r0949, interpret binary): Bit 0 = 1: It has been identified that the Control Unit has been replaced. Bit 1 = 1: It has been identified that the Motor Module/Hydraulic Module has been replaced. Bit 2 = 1: It has been identified that the Power Module has been replaced. Bit 3 = 1: It has been identified that the Sensor Module channel 1 has been replaced. Bit 4 = 1: It has been identified that the Sensor Module channel 2 has been replaced. Bit 5 = 1: It has been identified that the sensor channel 1 has been replaced. Bit 6 = 1: It has been identified that sensor channel 2 has been replaced.</p>
Remedy:	<ul style="list-style-type: none">- acknowledge component replacement (p9702 = 29).- save all parameters (p0977 = 1 or p0971 = 1 or "copy RAM to ROM").- acknowledge fault (e.g. BI: p2103). <p>Note: In addition to the fault, diagnostics bits r9776.2 and r9776.3 are set. See also: r9776 (SI diagnostics)</p>

F01641	SI P1 (CU): component replacement identified and save required
Message class:	General drive fault (19)
Reaction:	NONE
Acknowledge:	IMMEDIATELY
Cause:	<p>The "Safety Integrated" function integrated in the drive has identified that a component has been replaced. No additional fault response is initiated, therefore operation of the particular drive is not restricted. When safety functions are active, after a component has been replaced it is necessary to carry out a partial acceptance test. Fault value (r0949, interpret binary): Bit 0 = 1: It has been identified that the Control Unit has been replaced. Bit 1 = 1: It has been identified that the Motor Module/Hydraulic Module has been replaced. Bit 2 = 1: It has been identified that the Power Module has been replaced. Bit 3 = 1: It has been identified that the Sensor Module channel 1 has been replaced. Bit 4 = 1: It has been identified that the Sensor Module channel 2 has been replaced. Bit 5 = 1: It has been identified that the sensor channel 1 has been replaced. Bit 6 = 1: It has been identified that sensor channel 2 has been replaced.</p>
Remedy:	<ul style="list-style-type: none">- save all parameters (p0977 = 1 or p0971 = 1 or "copy RAM to ROM").- acknowledge fault (e.g. BI: p2103). <p>See also: r9776 (SI diagnostics)</p>

F01649 **SI P1 (CU): Internal software error**

Message class: Hardware/software error (1)
Reaction: OFF2
Acknowledge: IMMEDIATELY (POWER ON)
Cause: An internal error in the Safety Integrated software on processor 1 has occurred.
Note:
This fault results in a STOP A that cannot be acknowledged.
Fault value (r0949, interpret hexadecimal):
Only for internal Siemens troubleshooting.
Remedy:
- carry out a POWER ON (switch-off/switch-on).
- re-commission the "Safety Integrated" function and carry out a POWER ON.
- contact Technical Support.
- replace Control Unit.

F01650 **SI P1 (CU): Acceptance test required**

Message class: Safety monitoring channel has identified an error (10)
Reaction: OFF2
Acknowledge: IMMEDIATELY (POWER ON)
Cause: The drive-integrated "Safety Integrated" function on processor 1 requires an acceptance test.
Note:
This fault results in a STOP A that can be acknowledged.
Fault value (r0949, interpret decimal):
130: Safety parameters for processor 2 not available.
Note:
This fault value is always output when Safety Integrated is commissioned for the first time.
1000: Reference and actual checksum on processor 1 are not identical (booting).
- at least one checksum-checked piece of data is defective.
- safety parameters set offline and loaded into the Control Unit.
2000: Reference and actual checksum on processor 1 are not identical (commissioning mode).
- reference checksum incorrectly entered on processor 1 (p9799 not equal to r9798).
2001: Reference and actual checksum on processor 2 are not identical (commissioning mode).
- reference checksum incorrectly entered on processor 2 (p9899 not equal to r9898).
2002: Enable of safety-related functions between the processor 1 and processor 2 differ (p9601 not equal to p9801).
2003: Acceptance test is required as a safety parameter has been changed.
2004: An acceptance test is required because a project with enabled safety-functions has been downloaded.
2005: The Safety logbook has identified that a functional safety checksum has changed. An acceptance test is required.
2020: Error when saving the safety parameters for the processor 2.
9999: Subsequent response of another safety-related fault that occurred when booting that requires an acceptance test.

Remedy:	<p>For fault value = 130:</p> <ul style="list-style-type: none">- carry out safety commissioning routine. <p>For fault value = 1000:</p> <ul style="list-style-type: none">- again carry out safety commissioning routine.- replace the memory card or Control Unit.- Using STARTER, activate the safety parameters for the drive involved (change settings, copy parameters, activate settings). <p>For fault value = 2000:</p> <ul style="list-style-type: none">- check the safety parameters on processor 1 and adapt the reference checksum (p9799). <p>For fault value = 2001:</p> <ul style="list-style-type: none">- check the safety parameters on processor 2 and adapt the reference checksum (p9899). <p>For fault value = 2002:</p> <ul style="list-style-type: none">- enable the safety-related functions on processor 1 and check processor 2 (p9601 = p9801). <p>For fault value = 2003, 2004, 2005:</p> <ul style="list-style-type: none">- carry out an acceptance test and generate an acceptance report. <p>The fault with fault value 2005 can only be acknowledged when the "STO" function is de-selected.</p> <p>For fault value = 2020:</p> <ul style="list-style-type: none">- again carry out safety commissioning routine.- replace the memory card or Control Unit. <p>For fault value = 9999:</p> <ul style="list-style-type: none">- carry out diagnostics for the other safety-related fault that is present. <p>Note:</p> <p>STO: Safe Torque Off</p> <p>See also: p9799 (SI reference checksum SI parameters (processor 1)), p9899 (SI reference checksum SI parameters (processor 2))</p>
----------------	-------------------------------------------------------------------------------------------------------------------------------------------------------------------------------------------------------------------------------------------------------------------------------------------------------------------------------------------------------------------------------------------------------------------------------------------------------------------------------------------------------------------------------------------------------------------------------------------------------------------------------------------------------------------------------------------------------------------------------------------------------------------------------------------------------------------------------------------------------------------------------------------------------------------------------------------------------------------------------------------------------------------------------------------------------------------------------------------------------------------------------------------------------------------------------------------------------------------------------------------------------------------------------------------------------------------------------------------------------------------------------------------------------------------------------------------------------------------------------------------------------------------------------------------------------------------------------------------------------------------------------------------------------------------------------------------------------------------------------------------------------------------------

F01651	SI P1 (CU): Synchronization safety time slices unsuccessful
Message class:	Hardware/software error (1)
Reaction:	OFF2
Acknowledge:	IMMEDIATELY (POWER ON)
Cause:	<p>The "Safety Integrated" function requires synchronization of the safety time slices between processor 1 and processor 2. This synchronization routine was unsuccessful.</p> <p>Note:</p> <p>This fault results in a STOP A that cannot be acknowledged.</p> <p>Fault value (r0949, interpret decimal):</p> <p>Only for internal Siemens troubleshooting.</p>
Remedy:	Carry out a POWER ON (switch-off/switch-on).

F01653	SI P1 (CU): PROFIBUS/PROFINET configuration error
Message class:	Error in the parameterization / configuration / commissioning procedure (18)
Reaction:	NONE (OFF1, OFF2, OFF3)
Acknowledge:	IMMEDIATELY (POWER ON)
Cause:	<p>There is a PROFIBUS/PROFINET configuration error for using Safety Integrated monitoring functions with a higher-level control.</p> <p>Note:</p> <p>For safety functions that have been enabled, this fault results in a STOP A that cannot be acknowledged.</p> <p>Fault value (r0949, interpret decimal):</p> <p>200: A safety slot for receive data from the control has not been configured.</p> <p>210, 220: The configured safety slot for the receive data from the control has an unknown format.</p> <p>230: The configured safety slot for the receive data from the F-PLC has the incorrect length.</p> <p>231: The configured safety slot for the receive data from the F-PLC has the incorrect length.</p> <p>250: A PROFIsafe slot is configured in the higher-level F control, however PROFIsafe is not enabled in the drive.</p> <p>300: A safety slot for the send data to the control has not been configured.</p> <p>310, 320: The configured safety slot for the send data to the control has an unknown format.</p> <p>330: The configured safety slot for the send data to the F-PLC has the incorrect length.</p> <p>331: The configured safety slot for the send data to the F-PLC has the incorrect length.</p>

Remedy: The following generally applies:

- check and, if necessary, correct the PROFIBUS/PROFINET configuration of the safety slot on the master side.
- upgrade the Control Unit software.

For fault value = 250:

- remove the PROFIsafe configuring in the higher-level F control or enable PROFIsafe in the drive.

For fault value = 231, 331:

- configure PROFIsafe telegram 30 in the F-PLC.

A01654 (F) SI P1 (CU): Deviating PROFIsafe configuration

Message class: Error in the parameterization / configuration / commissioning procedure (18)

Reaction: NONE

Acknowledge: NONE

Cause: The configuration of a PROFIsafe telegram in the higher-level control (F-PLC) does not match the parameterization in the drive.

Note:
This message does not result in a safety stop response.
Alarm value (r2124, interpret decimal):
1:
A PROFIsafe telegram is configured in the higher-level control, however PROFIsafe is not enabled in the drive (p9601.3).
2:
PROFIsafe is parameterized in the drive; however, a PROFIsafe telegram has not been configured in the higher-level control.

Remedy: The following generally applies:

- check and, if necessary, correct the PROFIsafe configuration in the higher-level control.

For alarm value = 1:

- remove the PROFIsafe configuring in the higher-level F control or enable PROFIsafe in the drive.

For alarm value = 2:

- configure the PROFIsafe telegram to match the parameterization in the higher-level F-control.

F01655 SI P1 (CU): Align monitoring functions

Message class: Error in the parameterization / configuration / commissioning procedure (18)

Reaction: OFF2

Acknowledge: IMMEDIATELY (POWER ON)

Cause: An error has occurred when aligning the Safety Integrated monitoring functions on processor 1 and processor 2. No common set of supported SI monitoring functions was able to be determined.

- there is a communication error between processor 1 and processor 2 or communication has failed.

Note:
This fault results in a STOP A that cannot be acknowledged.
Fault value (r0949, interpret hexadecimal):
Only for internal Siemens troubleshooting.

Remedy:

- carry out a POWER ON (switch-off/switch-on).
- check the electrical cabinet design and cable routing for EMC compliance

F01656 SI P1 (CU): Parameter processor 2 error

Message class: Hardware/software error (1)

Reaction: OFF2

Acknowledge: IMMEDIATELY (POWER ON)

Cause: When accessing the Safety Integrated parameters for the processor 2 in the non-volatile memory, an error has occurred.

Note:
This fault results in a STOP A that can be acknowledged.
Fault value (r0949, interpret decimal):
129: Safety parameters for processor 2 corrupted.
131: Internal software error
132: Communication errors when uploading or downloading the safety parameters.
255: Internal software error on the Control Unit.

Remedy:

- re-commission the safety functions.
- replace the memory card or Control Unit.

For fault value = 129:

- activate the safety commissioning mode (p0010 = 95).
- adapt the PROFIsafe address (p9610).
- start the copy function for SI parameters (p9700 = D0 hex).
- acknowledge data change (p9701 = DC hex).
- exit the safety commissioning mode (p0010 = 0).
- save all parameters (p0971 = 1 or "copy RAM to ROM").
- carry out a POWER ON (switch-off/switch-on) for the Control Unit.

For fault value = 132:

- check the electrical cabinet design and cable routing for EMC compliance

F01658 **SI P1 (CU): PROFIsafe telegram number differ**

Message class: Error in the parameterization / configuration / commissioning procedure (18)

Reaction: OFF2

Acknowledge: IMMEDIATELY (POWER ON)

Cause: The PROFIsafe telegram number in p60022 is unsuitable for the enabled safety functions.

Possible causes:

- When PROFIsafe is not enabled (p9601.3 = 0), then it is not permissible to select a PROFIsafe telegram in p60022.
- When PROFIsafe is enabled (p9601.3 = 1), then a PROFIsafe telegram must be selected in p60022.

Note:
This fault does not result in a safety stop response.
See also: p9601 (SI enable functions integrated in the drive (processor 1)), p60022 (PROFIsafe telegram selection)

Remedy: Select the telegram number that matches the Safety functions that have been enabled.

F01659 **SI P1 (CU): Write request for parameter rejected**

Message class: Error in the parameterization / configuration / commissioning procedure (18)

Reaction: OFF2

Acknowledge: IMMEDIATELY (POWER ON)

Cause:	<p>The write request for one or several Safety Integrated parameters on processor 1 was rejected.</p> <p>Note: This fault does not result in a safety stop response. Fault value (r0949, interpret decimal): 1: The Safety Integrated password is not set. 2: A reset of the drive parameters was selected. However, the Safety Integrated parameters were not reset, as Safety Integrated is presently enabled. 3: The interconnected STO input is in the simulation mode. 10: An attempt was made to enable the STO function although this cannot be supported. 14: An attempt was made to enable the PROFIsafe communications although this cannot be supported. 15: An attempt was made to enable the motion monitoring functions integrated in the drive although these cannot be supported. 18: An attempt was made to enable the PROFIsafe function for Basic Functions although this cannot be supported. 20: An attempt was made to simultaneously enable both the drive-integrated motion monitoring functions via integrated F-DI and STO via terminals, even though these cannot be supported at the same time. 21: An attempt was made to enable the Safety Integrated Functions although these cannot be supported by the connected Power Module. 26: At a digital input of the Control Unit used by Safety Integrated, an attempt was made to activate the simulation mode. 28: An attempt was made to enable the "STO via terminals at the Power Module" function although this cannot be supported.</p> <p>See also: p0970 (Reset drive parameters), p3900 (Completion of quick commissioning), r9771 (SI common functions (processor 1)), r9871 (SI common functions (processor 2))</p>
Remedy:	<p>For fault value = 1: - set the Safety Integrated password (p9761).</p> <p>For fault value = 2: - inhibit Safety Integrated (p9501, p9601) or reset safety parameters (p0970 = 5), then reset the drive parameters again.</p> <p>For fault value = 3: - end the simulation mode for the digital input (p0795).</p> <p>For fault value = 10, 14, 15, 18: - check whether there are faults in the safety function alignment (F01655, F30655) and if required, carry out diagnostics for the faults involved. - use a Control Unit that supports the required function.</p> <p>For fault value = 20: - correct the enable setting (p9601).</p> <p>For fault value = 21: - use a Power Module that supports the Safety Integrated Functions.</p> <p>For fault value = 26: - deactivate the simulation mode for the set signal source for STO (p9620) (p0795). - deactivate the simulation mode (p0795) for the F-DIs used by the Safety Integrated Functions (r10049, p10006, p10009). - For the set test stop of the F-DO with feedback signal input (p10046, p10047), check the simulation mode, and if required, deactivate (p0795).</p> <p>For fault value = 28: use the power unit with the feature "STO via terminals at the Power Module".</p> <p>Note: F-DI: Failsafe Digital Input STO: Safe Torque Off</p> <p>See also: p9601 (SI enable functions integrated in the drive (processor 1)), p9761 (SI password input), p9801 (SI enable functions integrated in the drive (processor 2))</p>

F01660	SI P1 (CU): Safety-related functions not supported
Message class:	Error in the parameterization / configuration / commissioning procedure (18)
Reaction:	OFF2
Acknowledge:	IMMEDIATELY (POWER ON)

4 Faults and alarms

4.2 List of faults and alarms

Cause: The Power Module does not support the safety-related functions. Safety Integrated cannot be commissioned.
Note:
This fault does not result in a safety stop response.
Remedy: - use a Power Module that supports the safety-related functions.

F01662 Error internal communications

Message class: Hardware/software error (1)
Reaction: OFF2
Acknowledge: POWER ON
Cause: A module-internal communication error has occurred.
Fault value (r0949, interpret hexadecimal):
Only for internal Siemens troubleshooting.
Remedy: - carry out a POWER ON (switch-off/switch-on).
- check the electrical cabinet design and cable routing for EMC compliance
- check whether an impermissible voltage is connected at one of the digital outputs.
- check whether a digital output is loaded with an impermissible current.
- upgrade firmware to later version.
- contact Technical Support.

F01663 SI P1 (CU): Copying the SI parameters rejected

Message class: Error in the parameterization / configuration / commissioning procedure (18)
Reaction: OFF2
Acknowledge: IMMEDIATELY (POWER ON)
Cause: In p9700, the value 208 is saved or was entered offline.
This is the reason that when booting, an attempt is made to copy Safety Integrated parameters from processor 1 to processor 2. However, no safety-relevant function has been selected on processor 1 (p9601 = 0). This is the reason that copying is not possible.
Note:
This fault does not result in a safety stop response.
SI: Safety Integrated
See also: p9700 (SI Motion copy function)
Remedy: - set p9700 to 0.
- Check p9601 and if required, correct.
- restart the copying function by entering the corresponding value into p9700.

F01665 SI P1 (CU): System is defective

Message class: Hardware/software error (1)
Reaction: OFF2
Acknowledge: IMMEDIATELY
Cause: A system defect was detected before the last boot or in the actual one. The system might have been rebooted (reset).
Fault value (r0949, interpret hexadecimal):
200000 hex, 400000 hex, 8000yy hex (yy any):
- fault in the actual booting/operation.
Additional values:
- defect before the last time that the system booted.
Remedy: - carry out a POWER ON (switch-off/switch-on).
- upgrade firmware to later version.
- contact Technical Support.
For fault value = 200000 hex, 400000 hex, 8000yy hex (yy any):
- ensure that the Control Unit is connected to the Power Module.

F01690 SI Motion: Data save problem for the NVRAM

Message class: Hardware/software error (1)
Reaction: NONE (OFF1, OFF2, OFF3)
Acknowledge: POWER ON

Cause:	There is not sufficient memory space in the NVRAM on the drive to save parameters r9781 and r9782 (safety logbook). Note: This fault does not result in a safety stop response. Fault value (r0949, interpret decimal): 0: There is no physical NVRAM available in the drive. 1: There is no longer any free memory space in the NVRAM.
Remedy:	For fault value = 0: - use a Control Unit NVRAM. For fault value = 1: - de-select functions that are not required and that take up memory space in the NVRAM. - contact Technical Support. Note: NVRAM: Non-Volatile Random Access Memory (non-volatile read and write memory)

A01693 (F)	SI P1 (CU): Safety parameter setting changed, POWER ON required
Message class:	Error in the parameterization / configuration / commissioning procedure (18)
Reaction:	NONE
Acknowledge:	NONE
Cause:	Safety parameters have been changed; these will only take effect following a POWER ON. Notice: All changed parameters of the safety motion monitoring functions will only take effect following a POWER ON. Alarm value (r2124, interpret decimal): Parameter number of the safety parameter which has changed, necessitating a POWER ON.
Remedy:	- execute the function "Copy RAM to ROM". - carry out a POWER ON (switch-off/switch-on).

A01698 (F)	SI P1 (CU): Commissioning mode active
Message class:	General drive fault (19)
Reaction:	NONE
Acknowledge:	NONE
Cause:	The commissioning of the "Safety Integrated" function is selected. This message is withdrawn after the safety functions have been commissioned. Note: - this message does not result in a safety stop response. - in the safety commissioning mode, the "STO" function is internally selected. See also: p0010 (Drive commissioning parameter filter)
Remedy:	Not necessary.

A01699 (F)	SI P1 (CU): Test stop for STO required
Message class:	Safety monitoring channel has identified an error (10)
Reaction:	NONE
Acknowledge:	NONE
Cause:	The time set in p9659 for the forced checking procedure (test stop) for the "STO" function has been exceeded. A new forced checking procedure is required. After the next time the "STO" function is de-selected, the message is withdrawn and the monitoring time is reset. Note: - this message does not result in a safety stop response. - The test must be performed within a defined, maximum time interval (p9659, maximum of 9000 hours) in order to comply with the requirements as laid down in the standards for timely fault detection and the conditions to calculate the failure rates of safety functions (PFH value). Operation beyond this maximum time period is permissible if it can be ensured that the forced checking procedure is performed before persons enter the hazardous area and who are depending on the safety functions correctly functioning. See also: p9659 (SI forced checking procedure timer), r9660 (SI forced checking procedure remaining time)

Remedy: Select STO and then de-select again.

Note:

SI: Safety Integrated

STO: Safe Torque Off

A01788 SI: Automatic test stop waits for STO deselection via motion monitoring functions

Message class: Safety monitoring channel has identified an error (10)

Reaction: NONE

Acknowledge: NONE

Cause: The automatic test stop (forced checking procedure) was not able to be carried out after powering up.

Possible causes:

- the STO function is selected via safe motion monitoring functions.
- a safety message is present, that resulted in a STO.

Note:

STO: Safe Torque Off

Remedy: - deselect STO via safe motion monitoring functions.

- remove the cause of the safety messages and acknowledge the messages.

Note:

The automatic test stop is performed after removing the cause.

A01796 (F, N) SI P1 (CU): Wait for communication

Message class: Communication error to the higher-level control system (9)

Reaction: NONE

Acknowledge: NONE

Cause: The drive waits for communication to be established to execute the safety-relevant motion monitoring functions.

Note:

In this state, the pulses are safely suppressed.

Alarm value (r2124, interpret decimal):

3: Wait for communication to be established to PROFIsafe F-Host.

Remedy: If, after a longer period of time, the message is not automatically withdrawn, the following checks have to be made:

- check any other PROFIsafe communication messages/signals present and evaluate them.
- check the operating state of the F-Host.
- check the communication connection to the F Host.

See also: p9601 (SI enable functions integrated in the drive (processor 1)), p9801 (SI enable functions integrated in the drive (processor 2))

F01910 (N, A) Fieldbus: setpoint timeout

Message class: Communication error to the higher-level control system (9)

Reaction: OFF3 (IASC/DCBRK, NONE, OFF1, OFF2, STOP2)

Acknowledge: IMMEDIATELY

Cause: The reception of setpoints from the fieldbus interface has been interrupted.

- bus connection interrupted.

- communication partner switched off.

For AS-i (Actuator Sensor Interface): - observe the status in r2015.

See also: r2015 (AS-i state), p2040 (Fieldbus interface monitoring time)

Remedy: Ensure bus connection has been established and switch on communication partner.

- if required, adapt p2040.

A01945 PROFIBUS: Connection to the Publisher failed

Message class: Communication error to the higher-level control system (9)

Reaction: NONE

Acknowledge: NONE

Cause: For PROFIBUS peer-to-peer data transfer, the connection to at least one Publisher has failed.
Alarm value (r2124, interpret binary):
Bit 0 = 1: Publisher with address in r2077[0], connection failed.
...
Bit 15 = 1: Publisher with address in r2077[15], connection failed.

Remedy: Check the PROFIBUS cables.

F01946 (A) PROFIBUS: Connection to the Publisher aborted

Message class: Communication error to the higher-level control system (9)
Reaction: OFF1 (NONE, OFF2, OFF3)
Acknowledge: IMMEDIATELY (POWER ON)

Cause: The connection to at least one Publisher for PROFIBUS peer-to-peer data transfer in cyclic operation has been aborted.
Fault value (r0949, interpret binary):
Bit 0 = 1: Publisher with address in r2077[0], connection aborted.
...
Bit 15 = 1: Publisher with address in r2077[15], connection aborted.

Remedy: - check the PROFIBUS cables.
- check the state of the Publisher that has the aborted connection.

F01951 CU SYNC: Synchronization application clock cycle missing

Message class: Internal (DRIVE-CLiQ) communication error (12)
Reaction: OFF2 (NONE)
Acknowledge: IMMEDIATELY (POWER ON)

Cause: Internal synchronization of the application cycles unsuccessful.
Fault value (r0949, interpret decimal):
Only for internal Siemens troubleshooting.

Remedy: - carry out a POWER ON (switch-off/switch-on) for all components.
- upgrade the Control Unit software.

A01953 CU SYNC: Synchronization not completed

Message class: Internal (DRIVE-CLiQ) communication error (12)
Reaction: NONE
Acknowledge: NONE

Cause: After the drive system was switched on, synchronization between the basic clock cycle and application clock cycle was started but was not completed within the selected time tolerance.
Alarm value (r2124, interpret decimal):
Only for internal Siemens troubleshooting.

Remedy: Carry out a POWER ON (switch-off/switch-on).

A01991 AS-i: parameter setting inconsistent

Message class: Error in the parameterization / configuration / commissioning procedure (18)
Reaction: NONE
Acknowledge: NONE

Cause: Settings have been made using parameter p2013, which conflict with the setting made via p0015.
Alarm value (r2124, interpret decimal):
1, 4:
AS-i parameter assignment inconsistent. The values in the AS-i processor do not correspond to the settings in p2013.
2, 5:
AS-i parameter assignment inconsistent. The settings of p2013 and p0015 differ.
3, 6:
AS-i parameter assignment inconsistent. The values in the AS-i processor do not correspond to the settings in p2013 and the settings of p2013 and p0015 differ.
Note:
The first alarm value applies to the single slave – and the second, for the dual slave.

4 Faults and alarms

4.2 List of faults and alarms

Remedy:

- correct parameter p2013 corresponding to the setting of p0015.
- if required, change the setting of p0015.

Depending on the alarm value perform the remedy.

Single slave: p0015 = 30, 66

- 1: Change setting p2013 = 0 --> 2 --> 0 (single slave).
- 2: New setting, p0015 = 31 (dual slave) or change p2013 = 0 (single slave).
- 3: New setting, p0015 = 31 (dual slave) + change setting, P2013 = 2 --> 0 --> 2 (dual slave) or change p2013 = 2 --> 0 (single slave).

Dual slave: p0015 = 31

- 4: Change setting p2013 = 2 --> 0 --> 2 (dual slave)
- 5: New setting, p0015 = 30, 66 (single slave) or change p2013 = 2 (dual slave).
- 6: New setting p0015 = 30, 66 (single slave) + change setting p2013 = 0 --> 2 --> 0 (single slave) or change p2013 = 0 --> 2 (dual slave).

Note:

Changes to p2012 and p2013 are directly saved in the AS-i processor in a non-volatile fashion, and become immediately effective.

After changing a parameter, it should be saved in a non-volatile fashion (p0971 = 1 or "copy RAM to ROM").

AS-i: Actuator Sensor Interface

See also: p0015 (Macro drive unit), p2013 (AS-i mode)

A02050 Trace: Start not possible

Message class: Error in the parameterization / configuration / commissioning procedure (18)
Reaction: NONE
Acknowledge: NONE
Cause: The trace has already been started.
Remedy: Stop the trace and, if necessary, start again.

A02051 Trace: recording not possible as a result of know-how protection

Message class: Error in the parameterization / configuration / commissioning procedure (18)
Reaction: NONE
Acknowledge: NONE
Cause: TRACE recording is not possible as at least one signal or trigger signal being used is under know-how protection.
Alarm value (r2124, interpret decimal):
1: Recorder 0
2: Recorder 1
3: Recorders 0 and 1
Remedy:
- Temporarily activate or deactivate know-how protection (p7766).
- include the signal in the OEM exception list (p7763, p7764).
- Where relevant do not record the signal.
See also: p7763 (KHP OEM exception list number of indices for p7764), p7764 (KHP OEM exception list)

A02055 Trace: Recording time too short

Message class: Error in the parameterization / configuration / commissioning procedure (18)
Reaction: NONE
Acknowledge: NONE
Cause: The trace duration is too short.
The minimum is twice the value of the trace clock cycle.
Remedy: Check the selected recording time and, if necessary, adjust.

A02056 Trace: Recording cycle too short

Message class: Error in the parameterization / configuration / commissioning procedure (18)
Reaction: NONE
Acknowledge: NONE
Cause: The selected recording clock cycle is lower than the basic clock cycle 500µs.
Remedy: Increase the value for the trace cycle.

A02057	Trace: Time slice clock cycle invalid
Message class:	Error in the parameterization / configuration / commissioning procedure (18)
Reaction:	NONE
Acknowledge:	NONE
Cause:	The time slice clock cycle selected does not match any of the existing time slices.
Remedy:	Enter an existing time slice clock cycle. The existing time slices can be read out via p7901. See also: r7901 (Sampling times)

A02058	Trace: Time slice clock cycle for endless trace not valid
Message class:	Error in the parameterization / configuration / commissioning procedure (18)
Reaction:	NONE
Acknowledge:	NONE
Cause:	The selected time slice clock cycle cannot be used for the endless trace
Remedy:	Enter the clock cycle of an existing time slice with a cycle time ≥ 2 ms for up to 4 recording channels or ≥ 4 ms from 5 recording channels per trace. The existing time slices can be read out via p7901. See also: r7901 (Sampling times)

A02059	Trace: Time slice clock cycle for 2 x 8 recording channels not valid
Message class:	Error in the parameterization / configuration / commissioning procedure (18)
Reaction:	NONE
Acknowledge:	NONE
Cause:	The selected time slice clock cycle cannot be used for more than 4 recording channels.
Remedy:	Enter the clock cycle of an existing time slice with a cycle time ≥ 4 ms or reduce the number of recording channels to 4 per trace. The existing time slices can be read out via p7901. See also: r7901 (Sampling times)

A02060	Trace: Signal to be traced missing
Message class:	Error in the parameterization / configuration / commissioning procedure (18)
Reaction:	NONE
Acknowledge:	NONE
Cause:	- a signal to be traced was not specified. - the specified signals are not valid.
Remedy:	- specify the signal to be traced. - check whether the relevant signal can be traced.

A02061	Trace: Invalid signal
Message class:	Error in the parameterization / configuration / commissioning procedure (18)
Reaction:	NONE
Acknowledge:	NONE
Cause:	- the specified signal does not exist. - the specified signal can no longer be traced (recorded).
Remedy:	- specify the signal to be traced. - check whether the relevant signal can be traced.

A02062	Trace: Invalid trigger signal
Message class:	Error in the parameterization / configuration / commissioning procedure (18)
Reaction:	NONE
Acknowledge:	NONE
Cause:	- a trigger signal was not specified. - the specified signal does not exist. - the specified signal is not a fixed-point signal. - the specified signal cannot be used as a trigger signal for the trace.
Remedy:	Specify a valid trigger signal.

A02063	Trace: Invalid data type
Message class:	Error in the parameterization / configuration / commissioning procedure (18)
Reaction:	NONE
Acknowledge:	NONE
Cause:	The specified data type to select a signal using a physical address is invalid.
Remedy:	Use a valid data type.

A02070	Trace: Parameter cannot be changed
Message class:	Error in the parameterization / configuration / commissioning procedure (18)
Reaction:	NONE
Acknowledge:	NONE
Cause:	The trace parameter settings cannot be changed when the trace is active.
Remedy:	- stop the trace before parameterization. - if required, start the trace.

A02075	Trace: Pretrigger time too long
Message class:	Error in the parameterization / configuration / commissioning procedure (18)
Reaction:	NONE
Acknowledge:	NONE
Cause:	The selected pretrigger time must be shorter than the trace time.
Remedy:	Check the pretrigger time setting and change if necessary.

F02080	Trace: Parameterization deleted due to unit changeover
Message class:	Error in the parameterization / configuration / commissioning procedure (18)
Reaction:	NONE
Acknowledge:	IMMEDIATELY
Cause:	The trace parameterization in the drive unit was deleted due to a unit changeover or a change in the reference parameters.
Remedy:	Restart trace.

A02095	MTrace 0: multiple trace cannot be activated
Message class:	Error in the parameterization / configuration / commissioning procedure (18)
Reaction:	NONE
Acknowledge:	NONE
Cause:	The following functions or settings are not permissible in conjunction with a multiple trace (trace recorder 0): - measuring function - long-time trace - trigger condition "immediate recording start" (IMMEDIATE) - trigger condition "start with function generator" (FG_START)
Remedy:	- if required, deactivate the multiple trace (p4840[0] = 0). - deactivate function or setting that is not permissible

A02096	MTrace 0: cannot be saved
Message class:	Error in the parameterization / configuration / commissioning procedure (18)
Reaction:	NONE
Acknowledge:	NONE

Cause:	<p>It is not possible to save the measurement results of a multiple trace on the memory card (trace recorder 0). A multiple trace is not started or is canceled. Alarm value (r2124, interpret decimal): 1: Memory card cannot be accessed. - card is not inserted or is blocked by a mounted USB drive. 3: data save operation too slow. - a second trace has been completed before the measurement results of the first trace were able to be saved. - writing the measurement result files to the card is blocked by the parameter save. 4: Data save operation canceled. - for instance, the file required for the data save operation was not able to be found.</p>
Remedy:	<p>- insert or remove the memory card. - use a larger memory card. - configure a longer trace time or use an endless trace. - avoid saving parameters while a multiple trace is running. - check whether other functions are presently accessing measurement result files.</p>

A02097	MTrace 1: multiple trace cannot be activated
Message class:	Error in the parameterization / configuration / commissioning procedure (18)
Reaction:	NONE
Acknowledge:	NONE
Cause:	<p>The following functions or settings are not permissible in conjunction with a multiple trace (trace recorder 1): - measuring function - long-time trace - trigger condition "immediate recording start" (IMMEDIATE) - trigger condition "start with function generator" (FG_START)</p>
Remedy:	<p>- if required, deactivate the multiple trace (p4840[1] = 0). - deactivate function or setting that is not permissible</p>

A02098	MTrace 1: cannot be saved
Message class:	Error in the parameterization / configuration / commissioning procedure (18)
Reaction:	NONE
Acknowledge:	NONE
Cause:	<p>It is not possible to save the measurement results of a multiple trace on the memory card (trace recorder 1). A multiple trace is not started or is canceled. Alarm value (r2124, interpret decimal): 1: Memory card cannot be accessed. - card is not inserted or is blocked by a mounted USB drive. 3: data save operation too slow. - a second trace has been completed before the measurement results of the first trace were able to be saved. - writing the measurement result files to the card is blocked by the parameter save. 4: Data save operation canceled. - for instance, the file required for the data save operation was not able to be found.</p>
Remedy:	<p>- insert or remove the memory card. - use a larger memory card. - configure a longer trace time or use an endless trace. - avoid saving parameters while a multiple trace is running. - check whether other functions are presently accessing measurement result files.</p>

A02099	Trace: Insufficient Control Unit memory
Message class:	Error in the parameterization / configuration / commissioning procedure (18)
Reaction:	NONE
Acknowledge:	NONE
Cause:	The memory space still available on the Control Unit is no longer sufficient for the trace function.

Remedy: Reduce the memory required, e.g. as follows:

- reduce the trace time.
- increase the trace clock cycle.
- reduce the number of signals to be traced.

A02150 OA: Application cannot be loaded

Message class: Hardware/software error (1)

Reaction: NONE

Acknowledge: NONE

Cause: The system was not able to load an OA application.
Alarm value (r2124, interpret hexadecimal):

16:

The interface version in the DCB user library is not compatible to the DCC standard library that has been loaded.
Only for internal Siemens troubleshooting.

Remedy:

- carry out a POWER ON (switch-off/switch-on) for all components.
- upgrade firmware to later version.
- contact Technical Support.

For alarm value = 16:

Load a compatible DCB user library (compatible to the interface of the DCC standard library).

Note:

OA: Open Architecture

DCB: Drive Control Block

DCC: Drive Control Chart

F02151 (A) OA: Internal software error

Message class: Hardware/software error (1)

Reaction: OFF2 (NONE, OFF1, OFF3)

Acknowledge: IMMEDIATELY (POWER ON)

Cause: An internal software error has occurred within an OA application.
Fault value (r0949, interpret hexadecimal):
Only for internal Siemens troubleshooting.

Remedy:

- carry out a POWER ON (switch-off/switch-on) for all components.
- upgrade firmware to later version.
- contact Technical Support.
- replace the Control Unit.

Note:

OA: Open Architecture

F02152 (A) OA: Insufficient memory

Message class: Hardware/software error (1)

Reaction: OFF1

Acknowledge: IMMEDIATELY (POWER ON)

Cause: Too many functions have been configured on this Control Unit (e.g. too many drives, function modules, data sets, OA applications, blocks, etc.).
Fault value (r0949, interpret decimal):
Only for internal Siemens troubleshooting.

Remedy:

- change the configuration on this Control Unit (e.g. fewer drives, function modules, data sets, OA applications, blocks, etc.).
- use an additional Control Unit.

Note:

OA: Open Architecture

F03000 NVRAM fault on action

Message class: Hardware/software error (1)

Reaction: NONE

Acknowledge: IMMEDIATELY

Cause: A fault occurred during execution of action p7770 = 1 or 2 for the NVRAM data.
 Fault value (r0949, interpret hexadecimal):
 yyxx hex: yy = fault cause, xx = application ID
 yy = 1:
 The action p7770 = 1 is not supported by this version if Drive Control Chart (DCC) is activated for the drive object concerned.
 yy = 2:
 The data length of the specified application is not the same in the NVRAM and the backup.
 yy = 3:
 The data checksum in p7774 is not correct.
 yy = 4:
 No data available to load.

Remedy: - Perform the remedy according to the results of the troubleshooting.
 - if necessary, start the action again.

F03001 NVRAM checksum incorrect

Message class: Hardware/software error (1)
Reaction: NONE
Acknowledge: IMMEDIATELY
Cause: A checksum error occurred when evaluating the non-volatile data (NVRAM) on the Control Unit.
 The NVRAM data affected was deleted.
Remedy: Carry out a POWER ON (switch-off/switch-on) for all components.

F03505 (N, A) Analog input wire breakage

Message class: External measured value / signal state outside the permissible range (16)
Reaction: OFF1 (NONE, OFF2)
Acknowledge: IMMEDIATELY (POWER ON)
Cause: The wire-break monitoring for an analog input has responded.
 The input value of the analog input has undershot the threshold value parameterized in p0761[0...1].
 p0756[0]: Analog input 0
 p0756[1]: Analog input 1
 Fault value (r0949, interpret decimal):
 yxxx dec
 y = analog input (0 = analog input 0 (AI 0), 1 = analog input 1 (AI 1))
 xxx = component number (p0151)
Note:
 For the following analog input type, the wire breakage monitoring is active:
 p0756[0...1] = 1 (2 ... 10 V with monitoring)
 p0756[0...1] = 3 (4 mA ... +20 mA with monitoring)

Remedy: - Check the connection to the signal source for interruptions.
 - check the magnitude of the injected current - it is possible that the infed signal is too low.
Note:
 The input current measured by the analog input can be read in r0752[x].

A03510 (F, N) Calibration data not plausible

Message class: Hardware/software error (1)
Reaction: NONE
Acknowledge: NONE
Cause: During booting, the calibration data for the analog inputs is read and checked with respect to plausibility.
 At least one calibration data point was determined to be invalid.

Remedy: - switch-off/switch-on the power supply for the Control Unit.
Note:
 If it reoccurs, then replace the module.
 In principle, operation could continue.
 The analog channel involved possibly does not achieve the specified accuracy.

A03560	LRC: keyswitch in the off position
Message class:	Error in the parameterization / configuration / commissioning procedure (18)
Reaction:	NONE
Acknowledge:	NONE
Cause:	The drive cannot be moved as a result of a local remote control feedback signal. Alarm value (r2124, interpret decimal): 0: The keyswitch is in the "Off" position. 5: The cover of the Wiring Module or the local remote control was removed (r8559.8 = 1) . 6: The local remote control was not identified (r8559.10 = 1).
Remedy:	<p>Note: LRC: Local Remote Control For alarm value = 0: Set the keyswitch to another position ("manual operation" or "remote operation").</p> <p>For alarm value = 5: Attach the cover of the Wiring Module or the local remote control as described in the Operating Manual.</p> <p>For alarm value = 6: - Carry out a POWER ON (switch-off/switch-on). - Contact Technical Support. - Replace the local remote control.</p> <p>Note: Active faults are acknowledged if the keyswitch is turned from the "Off" position to "Manual operation" or "Remote operation". See also: r8559 (Local operator controls status)</p>
A03561	LRC: keyswitch in the manual operation position
Message class:	Error in the parameterization / configuration / commissioning procedure (18)
Reaction:	NONE
Acknowledge:	NONE
Cause:	For local remote control, the keyswitch is in the "Manual operation" position. Alarm value (r2124, interpret decimal): 0: The keyswitch is in the "Manual operation" position, and the drive should be remotely controlled. In this state, the motor can only be moved using the local remote control pushbuttons. 1: The drive is controlled via SAM/Startdrive, and the keyswitch is set to manual operation. In this case, the drive is inhibited (r8559.11 = 1).
Remedy:	<p>Note: LRC: Local Remote Control For alarm value = 0: - If required, set the keyswitch into the "Remote operation" position.</p> <p>For alarm value = 1: - Manual operation: withdraw the drive inhibit (relinquish master control to the drive, e.g. for Startdrive deactivate master control). - Master control from SAM/Startdrive: set the keyswitch to the "Remote operation" position.</p> <p>Note: Active faults are acknowledged if the keyswitch is turned from the "Off" position to "Manual operation" or "Remote operation". See also: r8559 (Local operator controls status)</p>

A05000 (N)	Power unit: Overtemperature heat sink AC inverter
Message class:	Power electronics faulted (5)
Reaction:	NONE
Acknowledge:	NONE
Cause:	The alarm threshold for overtemperature at the inverter heat sink has been reached. The response is set using p0290. If the heat sink temperature exceeds the value set in p0292[0], then fault F30004 is output.
Remedy:	Check the following: <ul style="list-style-type: none">- is the ambient temperature within the defined limit values?- have the load conditions and the load duty cycle been appropriately dimensioned?- has the cooling failed?

A05001 (N)	Power unit: Overtemperature depletion layer chip
Message class:	Power electronics faulted (5)
Reaction:	NONE
Acknowledge:	NONE
Cause:	Alarm threshold for overtemperature of the power semiconductor in the AC converter has been reached. Note: <ul style="list-style-type: none">- the response is set using p0290.- if the temperature of the barrier layer increases by the value set in p0292[1], then fault F30025 is initiated.
Remedy:	Check the following: <ul style="list-style-type: none">- is the ambient temperature within the defined limit values?- have the load conditions and the load duty cycle been appropriately dimensioned?- has the cooling failed?- pulse frequency too high? See also: r0037 (Power unit temperatures), p0290 (Power unit overload response)

A05002 (N)	Power unit: Air intake overtemperature
Message class:	Power electronics faulted (5)
Reaction:	NONE
Acknowledge:	NONE
Cause:	For chassis power units, the following applies: The alarm threshold for the air intake overtemperature has been reached. For air-cooled power units, the threshold is 42 °C (hysteresis 2 K). The response is set using p0290. If the air intake temperature increases by an additional 13 K, then fault F30035 is output.
Remedy:	Check the following: <ul style="list-style-type: none">- is the ambient temperature within the defined limit values?- has the fan failed? Check the direction of rotation.

A05004 (N)	Power unit: Rectifier overtemperature
Message class:	Power electronics faulted (5)
Reaction:	NONE
Acknowledge:	NONE
Cause:	The alarm threshold for the overtemperature of the rectifier has been reached. The response is set using p0290. If the temperature of the rectifier increases by an additional 5 K, then fault F30037 is triggered.
Remedy:	Check the following: <ul style="list-style-type: none">- is the ambient temperature within the defined limit values?- have the load conditions and the load duty cycle been appropriately dimensioned?- has the fan failed? Check the direction of rotation.- has a phase of the line supply failed?- is an arm of the supply (incoming) rectifier defective?

A05006 (N)	Power unit: Overtemperature thermal model
Message class:	Power electronics faulted (5)
Reaction:	NONE
Acknowledge:	NONE
Cause:	The temperature difference between the chip and heat sink has exceeded the permissible limit value (blocksize power units only). Depending on p0290, an appropriate overload response is initiated. See also: r0037 (Power unit temperatures)
Remedy:	Not necessary. The alarm disappears automatically once the limit value is undershot. Note: If the alarm does not disappear automatically and the temperature continues to rise, this can result in fault F30024. See also: p0290 (Power unit overload response)

A05065 (F, N)	Voltage measured values not plausible
Message class:	Power electronics faulted (5)
Reaction:	NONE
Acknowledge:	NONE
Cause:	The voltage measurement does not supply any plausible values and is not used. Alarm value (r2124, interpret bitwise binary): Bit 1: Phase U Bit 2: Phase V Bit 3: Phase W
Remedy:	The following parameterization must be made in order to deactivate the alarm: - Deactivate voltage measurement (p0247.0 = 0). - Deactivate flying restart with voltage measurement (p0247.5 = 0) and deactivate fast flying restart (p1780.11 = 0).

F05118 (A)	Precharging contactor simultaneity monitoring time exceeded
Message class:	Infeed faulted (13)
Reaction:	OFF2 (NONE, OFF1)
Acknowledge:	IMMEDIATELY (POWER ON)
Cause:	A feedback signal for the precharging contactor (ALM, SLM, BLM diode) or the line contactor (BLM thyristor) interconnected and the simultaneity monitoring (p0255[4, 6]) activated. After opening or closing a contactor of the parallel connection, after a monitoring time has elapsed, not all of the contactors have assumed the same state. Fault value (r0949, interpret binary): Bit 0 = 1: simultaneity error when closing the contactors. Bit 1 = 1: simultaneity error when opening the contactors. Bit 16 = 1: PDS0 contactor is closed. Bit 17 = 1: PDS1 contactor is closed. Bit 18 = 1: PDS2 contactor is closed. Bit 19 = 1: PDS3 contactor is closed. Bit 20 = 1: PDS4 contactor is closed. Bit 21 = 1: PDS5 contactor is closed. Bit 22 = 1: PDS6 contactor is closed. Bit 23 = 1: PDS7 contactor is closed. Note: PDS: Power unit Data Set
Remedy:	- check the monitoring time setting (p0255[4, 6]). - check the contactor wiring and activation. - if required, replace the contactor.

F05119 (A)	Bypass contactor simultaneity monitoring time exceeded
Message class:	Infeed faulted (13)
Reaction:	OFF2 (NONE, OFF1)
Acknowledge:	IMMEDIATELY (POWER ON)
Cause:	<p>A feedback signal for the bypass contactor is interconnected and the simultaneity monitoring (p0255[5, 7]) activated. After opening or closing a contactor of the parallel connection, after a monitoring time has elapsed, not all of the contactors have assumed the same state.</p> <p>Fault value (r0949, interpret binary):</p> <p>Bit 0 = 1: simultaneity error when closing the contactors. Bit 1 = 1: simultaneity error when opening the contactors. Bit 16 = 1: PDS0 contactor is closed. Bit 17 = 1: PDS1 contactor is closed. Bit 18 = 1: PDS2 contactor is closed. Bit 19 = 1: PDS3 contactor is closed. Bit 20 = 1: PDS4 contactor is closed. Bit 21 = 1: PDS5 contactor is closed. Bit 22 = 1: PDS6 contactor is closed. Bit 23 = 1: PDS7 contactor is closed.</p> <p>Note:</p> <p>PDS: Power unit Data Set</p>
Remedy:	<ul style="list-style-type: none">- check the monitoring time setting (p0255[5, 7]).- check the wiring and control of the contactor.- if required, replace the contactor.
<hr/>	
F06310 (A)	Supply voltage (p0210) incorrectly parameterized
Message class:	Network fault (2)
Reaction:	NONE (OFF1, OFF2)
Acknowledge:	IMMEDIATELY (POWER ON)
Cause:	<p>The measured DC voltage lies outside the tolerance range after precharging has been completed.</p> <p>Permissible range:</p> $1.16 * p0210 < r0070 < 1.8 * p0210$ <p>Note:</p> <p>The fault can only be acknowledged when the drive is switched off.</p> <p>See also: p0210 (Drive unit line supply voltage)</p>
Remedy:	<ul style="list-style-type: none">- check the parameterized supply voltage and if required change (p0210).- check the line supply voltage. <p>See also: p0210 (Drive unit line supply voltage)</p>
<hr/>	
A06921 (N)	Braking resistor phase asymmetry
Message class:	Braking Module faulted (14)
Reaction:	NONE
Acknowledge:	NONE
Cause:	<ul style="list-style-type: none">- the three resistors of the braking chopper are not symmetrical.- DC link voltage oscillations caused by fluctuating loads of the connected drives.
Remedy:	<ul style="list-style-type: none">- check the feeder cables to the braking resistors.- if required, increase the value for detecting asymmetry (p1364).
<hr/>	
F06922	Braking resistor phase failure
Message class:	Braking Module faulted (14)
Reaction:	NONE
Acknowledge:	IMMEDIATELY

4 Faults and alarms

4.2 List of faults and alarms

Cause: A phase failure for the brake resistor was detected.
Fault value (r0949, interpret decimal):
11: Phase U
12: Phase V
13: Phase W
See also: p3235 (Phase failure signal motor monitoring time)

Remedy: Check the feeder cables to the braking resistors.

F07011**Drive: Motor overtemperature**

Message class: Motor overload (8)

Reaction: OFF2 (NONE, OFF1, OFF3, STOP2)

Acknowledge: IMMEDIATELY

Cause: KTY84/PT1000:

The motor temperature has exceeded the fault threshold (p0605) or the timer (p0606) after the alarm threshold was exceeded (p0604) has expired. The response parameterized in p0610 becomes active. The alarm is withdrawn if the response threshold for wire breakage or sensor not connected is exceeded ($R > 2120 \text{ Ohm}$).

PTC or bimetallic NC contact:

The response threshold of 1650 Ohm was exceeded or the NC contact opened and the timer (p0606) has expired. The response parameterized in p0610 becomes active.

Possible causes:

- motor is overloaded.
- motor ambient temperature too high.
- wire breakage or sensor not connected.

Fault value (r0949, interpret decimal):

200:

Motor temperature model 1 (I2t): temperature too high.

See also: p0604, p0605, p0606, p0612, p0613, p0625, p0626, p0627, p0628

Remedy:

- reduce the motor load.
 - check the ambient temperature and the motor ventilation.
 - check the wiring and the connection of the PTC or bimetallic NC contact.
- See also: p0604, p0605, p0606, p0612, p0625, p0626, p0627, p0628

A07012 (N)**Drive: Motor temperature model 1/3 overtemperature**

Message class: Motor overload (8)

Reaction: NONE

Acknowledge: NONE

Cause: The motor temperature model 1/3 identified that the alarm threshold was exceeded.

Hysteresis:2K.

Alarm value (r2124, interpret decimal):

200:

Motor temperature model 1 (I2t): temperature too high.

300:

Motor temperature model 3: temperature too high.

See also: r0034 (Motor utilization thermal), p0605 (Mot_temp_mod 1/2/sensor threshold and temperature value), p0611 (I2t motor model thermal time constant), p0612 (Mot_temp_mod activation), p0613 (Mot_temp_mod 1/3 ambient temperature)

Remedy:

- check the motor load and if required, reduce.
- check the motor ambient temperature.
- check activation of the motor temperature model (p0612).

Motor temperature model 1 (I2t):

- check the thermal time constant (p0611).
- check alarm threshold.

Motor temperature model 3:

- check the motor type.
- check alarm threshold.
- check the model parameters.

See also: r0034 (Motor utilization thermal), p0605 (Mot_temp_mod 1/2/sensor threshold and temperature value), p0611 (I2t motor model thermal time constant), p0612 (Mot_temp_mod activation), r5397 (Mot_temp_mod 3 ambient temperature image p0613)

A07014 (N) Drive: Motor temperature model configuration alarm

Message class: Motor overload (8)
Reaction: NONE
Acknowledge: NONE
Cause: A fault has occurred in the configuration of the motor temperature model.
 Alarm value (r2124, interpret decimal):
 1:
 All motor temperature models: It is not possible to save the model temperature
 See also: p0610 (Motor overtemperature response)
Remedy:
 - set the response for motor overtemperature to "Alarm and fault, no reduction of I_max" (p0610 = 2).
 See also: p0610 (Motor overtemperature response)

A07015 Drive: Motor temperature sensor alarm

Message class: External measured value / signal state outside the permissible range (16)
Reaction: NONE
Acknowledge: NONE
Cause: An error was detected when evaluating the temperature sensor set in p0601.
 With the fault, the time in p0607 is started. If the fault is still present after this time has expired, then fault F07016 is output; however, at the earliest, 50 ms after alarm A07015.
 Possible causes:
 - wire breakage or sensor not connected (KTY: R > 2120 Ohm, PT1000: R > 2120 Ohm).
 - measured resistance too low (PTC: R < 20 Ohm, KTY: R < 50 Ohm, PT1000: R < 603 Ohm).
Remedy:
 - make sure that the sensor is connected correctly.
 - check the parameterization (p0601).
 See also: r0035 (Motor temperature), p0601 (Motor temperature sensor type), p0607 (Temperature sensor fault timer)

F07016 Drive: Motor temperature sensor fault

Message class: External measured value / signal state outside the permissible range (16)
Reaction: OFF1 (NONE, OFF2, OFF3, STOP2)
Acknowledge: IMMEDIATELY
Cause: An error was detected when evaluating the temperature sensor set in p0601.
 Possible causes:
 - wire breakage or sensor not connected (KTY: R > 2120 Ohm, PT1000: R > 2120 Ohm).
 - measured resistance too low (PTC: R < 20 Ohm, KTY: R < 50 Ohm, PT1000: R < 603 Ohm).
Note:
 If alarm A07015 is present, the time in p0607 is started. If the fault is still present after this time has expired, then fault F07016 is output; however, at the earliest, 50 ms after alarm A07015.
 See also: p0607 (Temperature sensor fault timer)

4 Faults and alarms

4.2 List of faults and alarms

Remedy:

- make sure that the sensor is connected correctly.
- check the parameterization (p0601).
- induction motors: Deactivate temperature sensor fault (p0607 = 0).

See also: r0035 (Motor temperature), p0601 (Motor temperature sensor type), p0607 (Temperature sensor fault timer)

F07080 **Drive: Incorrect control parameter**

Message class: Error in the parameterization / configuration / commissioning procedure (18)

Reaction: NONE

Acknowledge: IMMEDIATELY (POWER ON)

Cause: The closed-loop control parameters have been parameterized incorrectly (e.g. p0356 = L_spread = 0).
Fault value (r0949, interpret decimal):
The fault value includes the parameter number involved.
See also: p0310, p0311, p0341, p0344, p0350, p0354, p0356, p0357, p0358, p0360, p0400, p0408, p0640, p1082, p1300

Remedy: Modify the parameter indicated in the fault value (r0949) (e.g. p0640 = current limit > 0).
See also: p0311, p0341, p0344, p0350, p0354, p0356, p0358, p0360, p0400, p0408, p0640, p1082

F07082 **Macro: Execution not possible**

Message class: Error in the parameterization / configuration / commissioning procedure (18)

Reaction: NONE

Acknowledge: IMMEDIATELY

Cause: The macro cannot be executed.
Fault value (r0949, interpret hexadecimal):
ccccbaa hex:
cccc = preliminary parameter number, bb = supplementary information, aa = fault cause
Fault causes for the trigger parameter itself:
19: Called file is not valid for the trigger parameter.
20: Called file is not valid for parameter 15.
21: Called file is not valid for parameter 700.
22: Called file is not valid for parameter 1000.
23: Called file is not valid for parameter 1500.
24: Data type of a TAG is incorrect (e.g. Index, number or bit is not U16).
Fault causes for the parameters to be set:
25: Error level has an undefined value.
26: Mode has an undefined value.
27: A value was entered as string in the tag value that is not "DEFAULT".
31: Entered drive object type unknown.
32: A device was not able to be found for the determined drive object number.
34: A trigger parameter was recursively called.
35: It is not permissible to write to the parameter via macro.
36: Check, writing to a parameter unsuccessful, parameter can only be read, not available, incorrect data type, value range or assignment incorrect.
37: Source parameter for a BICO interconnection was not able to be determined.
38: An index was set for a non-indexed (or CDS-dependent) parameter.
39: No index was set for an indexed parameter.
41: A bit operation is only permissible for parameters with the parameter format DISPLAY_BIN.
42: A value not equal to 0 or 1 was set for a BitOperation.
43: Reading the parameter to be changed by the BitOperation was unsuccessful.
51: Factory setting for DEVICE may only be executed on the DEVICE.
61: The setting of a value was unsuccessful.

Remedy:

- check the parameter involved.
- check the macro file and BICO interconnection.

See also: p0015, p1000, p1500

F07083	Macro: ACX file not found
Message class:	Error in the parameterization / configuration / commissioning procedure (18)
Reaction:	NONE
Acknowledge:	IMMEDIATELY
Cause:	The ACX file (macro) to be executed was not able to be found in the appropriate directory. Fault value (r0949, interpret decimal): Parameter number with which the execution was started. See also: p0015, p1000, p1500
Remedy:	- check whether the file is saved in the appropriate directory on the memory card.
F07084	Macro: Condition for WaitUntil not fulfilled
Message class:	Error in the parameterization / configuration / commissioning procedure (18)
Reaction:	NONE
Acknowledge:	IMMEDIATELY
Cause:	The WaitUntil condition set in the macro was not fulfilled in a certain number of attempts. Fault value (r0949, interpret decimal): Parameter number for which the condition was set.
Remedy:	Check and correct the conditions for the WaitUntil loop.
F07086	Units changeover: Parameter limit violation due to reference value change
Message class:	Error in the parameterization / configuration / commissioning procedure (18)
Reaction:	NONE
Acknowledge:	IMMEDIATELY
Cause:	A reference parameter was changed in the system. This resulted in the fact that for the parameters involved, the selected value was not able to be written in the per unit notation. The values of the parameters were set to the corresponding violated minimum limit/maximum limit or to the factory setting. Possible causes: - the steady-state minimum limit/maximum limit or that defined in the application was violated. Fault value (r0949, parameter): Diagnostics parameter to display the parameters that were not able to be re-calculated. See also: p0304, p0305, p0310, p0596, p2000, p2001, p2002, p2003, r2004
Remedy:	Check the adapted parameter value and if required correct.
F07088	Units changeover: Parameter limit violation due to units changeover
Message class:	Error in the parameterization / configuration / commissioning procedure (18)
Reaction:	NONE
Acknowledge:	IMMEDIATELY
Cause:	A changeover of units was initiated. This resulted in a violation of a parameter limit Possible causes for the violation of a parameter limit: - When rounding off a parameter corresponding to its decimal places, the steady-state minimum limit or maximum limit was violated. - inaccuracies for the data type "FloatingPoint". In these cases, when the minimum limit is violated then the parameter value is rounded up and when the maximum limited is violated the parameter value is rounded down. Fault value (r0949, interpret decimal): Diagnostics parameter r9451 to display all parameters whose value had to be adapted. See also: p0100 (IEC/NEMA Standards), p0505 (Selecting the system of units), p0595 (Technological unit selection)
Remedy:	Check the adapted parameter values and if required correct. See also: r9451 (Units changeover adapted parameters)
A07089	Changing over units: Function module activation is blocked because the units have been changed over
Message class:	Error in the parameterization / configuration / commissioning procedure (18)
Reaction:	NONE
Acknowledge:	NONE

4 Faults and alarms

4.2 List of faults and alarms

Cause: An attempt was made to activate a function module. This is not permissible if the units have already been changed over.

See also: p0100 (IEC/NEMA Standards), p0505 (Selecting the system of units)

Remedy: Restore units that have been changed over to the factory setting.

A07092 Drive: moment of inertia estimator still not ready

Message class: Error in the parameterization / configuration / commissioning procedure (18)

Reaction: NONE

Acknowledge: NONE

Cause: The moment of inertia estimator still has no valid values.

The acceleration cannot be calculated.

The moment of inertia estimator is ready, if the frictional values (p1563, p1564) as well as the moment of inertia value (p1493) have been determined (r1407.26 = 1).

Remedy: Repeat the operation when the moment of inertia estimator is ready (r1407.26 = 1).

A07094 General parameter limit violation

Message class: Hardware/software error (1)

Reaction: NONE

Acknowledge: NONE

Cause: As a result of the violation of a parameter limit, the parameter value was automatically corrected.

Minimum limit violated --> parameter is set to the minimum value.

Maximum limit violated --> parameter is set to the maximum value.

Alarm value (r2124, interpret decimal):

Parameter number, whose value had to be adapted.

Remedy: Check the adapted parameter values and if required correct.

A07200 Drive: Master control ON command present

Message class: Error in the parameterization / configuration / commissioning procedure (18)

Reaction: NONE

Acknowledge: NONE

Cause: The ON/OFF1 command is present (no 0 signal).

The command is either influenced via binector input p0840 (current CDS) or control word bit 0 via the master control.

Remedy: Switch the signal via binector input p0840 (current CDS) or control word bit 0 via the master control to 0.

F07220 (N, A) Drive: Master control by PLC missing

Message class: Communication error to the higher-level control system (9)

Reaction: OFF1 (NONE, OFF2, OFF3, STOP2)

Acknowledge: IMMEDIATELY

Cause: The "master control by PLC" signal was missing in operation.

- interconnection of the binector input for "master control by PLC" is incorrect (p0854).

- the higher-level control has withdrawn the "master control by PLC" signal.

- data transfer via the fieldbus (master/drive) was interrupted.

Remedy: - check the interconnection of the binector input for "master control by PLC" (p0854).

- check the "master control by PLC" signal and, if required, switch in.

- check the data transfer via the fieldbus (master/drive).

Note:

If the drive should continue to operate after withdrawing "master control by PLC" then fault response must be parameterized to NONE or the message type should be parameterized as alarm.

F07300 (A) Drive: Line contactor feedback signal missing

Message class: Auxiliary unit faulted (20)

Reaction: OFF2 (NONE)

Acknowledge: IMMEDIATELY

- Cause:**
- the line contactor was not able to be closed within the time in p0861.
 - the line contactor was not able to be opened within the time in p0861.
 - the line contactor dropped out during operation
 - the line contactor has closed although the drive converter is switched off.
- Remedy:**
- check the setting of p0860.
 - check the feedback circuit from the line contactor.
 - increase the monitoring time in p0861.
- See also: p0860 (Line contactor feedback signal), p0861 (Line contactor monitoring time)

- F07320 Drive: Automatic restart interrupted**
- Message class:** Application/technological function faulted (17)
- Reaction:** OFF2
- Acknowledge:** IMMEDIATELY
- Cause:**
- the specified number of restart attempts (p1211) has been completely used up because within the monitoring time (p1213) the faults were not able to be acknowledged. The number of restart attempts (p1211) is decremented at each new start attempt.
 - the monitoring time for the power unit has expired (p0857).
 - when exiting commissioning or at the end of the motor identification routine or the speed controller optimization, the drive unit is not automatically switched on again.
- Fault value (r0949, interpret hexadecimal):
Only for internal Siemens troubleshooting.
- Remedy:**
- increase the number of restart attempts (p1211). The actual number of starting attempts is displayed in r1214.
 - increase the delay time in p1212 and/or the monitoring time in p1213.
 - either increase or disable the monitoring time of the power unit (p0857).
 - reduce the delay time to reset the start counter (p1213[1]) so that fewer faults are registered in the time interval.

- A07321 Drive: Automatic restart active**
- Message class:** Application/technological function faulted (17)
- Reaction:** NONE
- Acknowledge:** NONE
- Cause:**
- The automatic restart (AR) is active. When the line supply returns and/or the causes of the existing faults are removed the drive is automatically restarted. The pulses are enabled and the motor starts to rotate.
For p1210 = 26, restarting is realized with the delayed setting of the ON command.
- Remedy:**
- the automatic restart (AR) should, if required, be inhibited (p1210 = 0).
 - an automatic restart can be directly interrupted by withdrawing the switch-on command (BI: p0840).
 - for p1210 = 26: by withdrawing the OFF2- / OFF3 command.

- F07330 Flying restart: Measured search current too low**
- Message class:** Application/technological function faulted (17)
- Reaction:** OFF2 (NONE, OFF1)
- Acknowledge:** IMMEDIATELY
- Cause:**
- During a flying restart, it was identified that the search current reached is too low.
It is possible that the motor is not connected.
- Remedy:**
- Check the motor feeder cables.

- F07331 Flying restart: Function not supported**
- Message class:** Error in the parameterization / configuration / commissioning procedure (18)
- Reaction:** OFF2 (NONE, OFF1)
- Acknowledge:** IMMEDIATELY
- Cause:**
- It is not possible to power up with the motor rotating (no flying restart).
- Remedy:**
- Deactivate the "flying restart" function (p1200 = 0).

- F07332 Flying restart: maximum speed reduced**
- Message class:** Error in the parameterization / configuration / commissioning procedure (18)
- Reaction:** OFF2 (NONE, OFF1)
- Acknowledge:** IMMEDIATELY

4 Faults and alarms

4.2 List of faults and alarms

Cause: The maximum speed that can be reached is reduced; at very high speeds problems associated with the flying restart can be encountered.
Possible causes:
- power ratio, power unit/motor too high

Remedy: Parameter changes are not required.
Note:
A flying restart at speeds above 3000 rpm should be avoided.

A07352 Drive: Stop sensor not plausible

Message class: Application/technological function faulted (17)
Reaction: NONE
Acknowledge: NONE

Cause: The stop sensors are not plausible.
Possible causes:
- BICO interconnections are not OK (p3384, p3385, p3386).
- sensors are not supplying a valid signal (both supply a 0 signal or a 1 signal).

Remedy: - check the BICO interconnections for the stop sensors.
- check the sensors.
See also: p3384 (Stop sensor positive direction signal source), p3385 (Stop sensor negative direction signal source), p3386 (Stop sensor center signal source)

A07353 Drive: DC quantity control deactivated

Message class: Motor overload (8)
Reaction: NONE
Acknowledge: NONE

Cause: The DC quantity control has deactivated itself.
The manipulated variable of the DC quantity control was at its limit.

Remedy: Optimize the DC quantity controller (Kp, Tn, bandwidth, PT2 filter).
Note:
After changing the corresponding parameters, the DC quantity control is re-enabled and the alarm is automatically withdrawn.
See also: p3857 (DC quantity controller P gain), p3858 (DC quantity controller integral time)

A07400 (N) Drive: DC link voltage maximum controller active

Message class: Application/technological function faulted (17)
Reaction: NONE
Acknowledge: NONE

Cause: The DC link voltage controller has been activated because the upper switch-in threshold has been exceeded (r1242, r1282).
The ramp-down times are automatically increased in order to maintain the DC link voltage (r0070) within the permissible limits. There is a system deviation between the setpoint and actual speeds.
When the DC link voltage controller is switched out (disabled), this is the reason that the ramp-function generator output is set to the speed actual value.
See also: r0056 (Status word, closed-loop control), p1240 (Vdc controller configuration (vector control)), p1280 (Vdc controller or Vdc monitoring configuration (U/f))

Remedy: If the controller is not to intervene:
- increase the ramp-down times.
- switch off the Vdc_max controller (p1240 = 0 for vector control, p1280 = 0 for U/f control).
If the ramp-down times are not to be changed:
- use a chopper or regenerative feedback unit.

A07401 (N) Drive: DC link voltage maximum controller deactivated

Message class: Application/technological function faulted (17)
Reaction: NONE
Acknowledge: NONE

Cause:	The Vdc_max controller can no longer maintain the DC link voltage (r0070) below the limit value (r1242, r1282) and was therefore switched out (disabled). - the line supply voltage is permanently higher than specified for the power unit. - the motor is permanently in the regenerative mode as a result of a load that is driving the motor.
Remedy:	- check whether the input voltage is within the permissible range (if required, increase the value in p0210). - check whether the load duty cycle and load limits are within the permissible limits.

A07402 (N)	Drive: DC link voltage minimum controller active
Message class:	Application/technological function faulted (17)
Reaction:	NONE
Acknowledge:	NONE
Cause:	The DC link voltage controller has been activated as the lower switch-in threshold has been undershot (r1246, r1286). The kinetic energy of the motor is used to buffer the DC link. The drive is therefore braked. See also: r0056 (Status word, closed-loop control), p1240 (Vdc controller configuration (vector control)), p1280 (Vdc controller or Vdc monitoring configuration (U/f))
Remedy:	The alarm disappears when power supply returns.

F07404	Drive: DC link voltage monitoring Vdc_max
Message class:	DC link overvoltage (4)
Reaction:	OFF2 (NONE, OFF1, OFF3)
Acknowledge:	IMMEDIATELY
Cause:	The monitoring of the DC link voltage p1284 has responded (only U/f control).
Remedy:	- check the line supply voltage. - check the braking module. - adapt the device supply voltage (p0210). - adapt the DC link voltage monitoring (p1284).

F07405 (N, A)	Drive: Kinetic buffering minimum speed fallen below
Message class:	Application/technological function faulted (17)
Reaction:	OFF2 (IASC/DCBRK, NONE, OFF1, OFF3, STOP2)
Acknowledge:	IMMEDIATELY
Cause:	During kinetic buffering the speed fell below minimum speed (p1257 or p1297 for vector drives with U/f control) and the line supply did not return.
Remedy:	Check the speed threshold for the Vdc_min controller (kinetic buffering) (p1257, p1297). See also: p1257 (Vdc_min controller speed threshold)

F07406 (N, A)	Drive: Kinetic buffering maximum time exceeded
Message class:	Application/technological function faulted (17)
Reaction:	OFF3 (IASC/DCBRK, NONE, OFF1, OFF2, STOP2)
Acknowledge:	IMMEDIATELY
Cause:	The maximum buffer time (p1255 and p1295 for vector drives with U/f control) has been exceeded without the line supply having returned.
Remedy:	Check the time threshold for Vdc-min controller (kinetic buffering) (p1255, p1295). See also: p1255 (Vdc_min controller time threshold)

A07409 (N)	Drive: U/f control, current limiting controller active
Message class:	Application/technological function faulted (17)
Reaction:	NONE
Acknowledge:	NONE
Cause:	The current limiting controller of the U/f control was activated because the current limit was exceeded.
Remedy:	The alarm is automatically withdrawn after one of the following measures: - increase current limit (p0640). - reduce the load. - slow down the ramp up to the setpoint speed.

F07410	Drive: Current controller output limited
Message class:	Application/technological function faulted (17)
Reaction:	OFF2 (NONE, OFF1)
Acknowledge:	IMMEDIATELY
Cause:	The condition " $I_{act} = 0$ and $U_{q_set_1}$ longer than 16 ms at its limit" is present and can be caused by the following: <ul style="list-style-type: none">- motor not connected or motor contactor open.- motor data and motor configuration (star-delta) do not match.- no DC link voltage present.- power unit defective.- the "flying restart" function is not activated.
Remedy:	<ul style="list-style-type: none">- connect the motor or check the motor contactor.- check the motor parameterization and the connection type (star-delta).- check the DC link voltage (r0070).- check the power unit.- activate the "flying restart" function (p1200).

F07411	Drive: Flux setpoint not reached when building up excitation
Message class:	Application/technological function faulted (17)
Reaction:	OFF2
Acknowledge:	IMMEDIATELY
Cause:	When quick magnetizing is configured ($p1401.6 = 1$) the specified flux setpoint is not reached although 90% of the maximum current is specified. <ul style="list-style-type: none">- incorrect motor data.- motor data and motor configuration (star-delta) do not match.- the current limit has been set too low for the motor.- induction motor (encoderless, open-loop controlled) in I_{2t} limiting.- power unit is too small.- the magnetizing time is too short.
Remedy:	<ul style="list-style-type: none">- correct the motor data. Perform motor data identification and rotating measurement.- check the motor configuration.- correct the current limits (p0640).- reduce the induction motor load.- if necessary, use a larger power unit.- check motor supply cable.- check power unit.- increase p0346.

A07416	Drive: Flux controller configuration
Message class:	Error in the parameterization / configuration / commissioning procedure (18)
Reaction:	NONE
Acknowledge:	NONE
Cause:	The configuration of the flux control (p1401) is contradictory. Alarm value (r2124, interpret hexadecimal): cbbaaaa hex aaaa = Parameter bb = Index cc = fault cause 1: Quick magnetizing (p1401.6) for soft starting (p1401.0). 2: Quick magnetizing for flux build-up control (p1401.2). 3: Quick magnetizing (p1401.6) for R _s identification after restart (p0621 = 2).

Remedy: For fault cause = 1:
- Shut down soft start (p1401.0 = 0).
- Shut down quick magnetizing (p1401.6 = 0).
For fault cause = 2:
- switch-on flux build-up control (p1401.2 = 1).
- Shut down quick magnetizing (p1401.6 = 0).
For fault cause = 3:
- Re-parameterize Rs identification (p0621 = 0, 1)
- Shut down quick magnetizing (p1401.6 = 0).

F07426 (A) Technology controller actual value limited
Message class: Application/technological function faulted (17)
Reaction: OFF1 (IASC/DCBRK, NONE, OFF2, OFF3)
Acknowledge: IMMEDIATELY
Cause: The actual value for the technology controller, interconnected via connector input p2264, has reached a limit.
Fault value (r0949, interpret decimal):
1: upper limit reached.
2: lower limit reached.
Remedy: - adapt the limits to the signal level (p2267, p2268).
- check the actual value normalization (p0595, p0596).
See also: p0595 (Technological unit selection), p0596 (Technological unit reference quantity), p2264 (Technology controller actual value), p2267 (Technology controller upper limit actual value), p2268 (Technology controller lower limit actual value)

A07428 (N) Technology controller parameterizing error
Message class: Error in the parameterization / configuration / commissioning procedure (18)
Reaction: NONE
Acknowledge: NONE
Cause: The technology controller has a parameterizing error.
Alarm value (r2124, interpret decimal):
1:
The upper output limit in p2291 is set lower than the lower output limit in p2292.
Remedy: For alarm value = 1:
Set the output limit in p2291 higher than in p2292.
See also: p2291 (Technology controller maximum limiting), p2292 (Technology controller minimum limiting)

F07435 (N) Drive: Setting the ramp-function generator for sensorless vector control
Message class: Application/technological function faulted (17)
Reaction: OFF2 (IASC/DCBRK, NONE, OFF1, OFF3)
Acknowledge: IMMEDIATELY
Cause: During operation with sensorless vector control (r1407.1) the ramp-function generator was stopped (p1141). An internal setting command of the ramp-function generator output caused the set setpoint speed to be frozen.
Remedy: - deactivate the holding command for the ramp-function generator (p1141).
- suppress the fault (p2101, p2119). This is necessary if the ramp-function generator is held using jogging and the speed setpoint is simultaneously inhibited (r0898.6).

A07530 Drive: Drive Data Set DDS not present
Message class: Error in the parameterization / configuration / commissioning procedure (18)
Reaction: NONE
Acknowledge: NONE
Cause: The selected drive data set is not available (p0837 > p0180). The drive data set was not changed over.
See also: p0180 (Number of Drive Data Sets (DDS)), p0820 (Drive Data Set selection DDS bit 0), p0821 (Drive Data Set selection DDS bit 1), r0837 (Drive Data Set DDS selected)
Remedy: - select the existing drive data set.
- set up additional drive data sets.

A07531	Drive: Command Data Set CDS not present
Message class:	Error in the parameterization / configuration / commissioning procedure (18)
Reaction:	NONE
Acknowledge:	NONE
Cause:	The selected command data set is not available (p0836 > p0170). The command data set was not changed over. See also: p0810 (Command data set selection CDS bit 0), p0811 (Command data set selection CDS bit 1), r0836 (Command Data Set CDS selected)
Remedy:	- select the existing command data set. - set up additional command data sets.

F07754	Drive: Incorrect shutoff valve configuration
Message class:	Error in the parameterization / configuration / commissioning procedure (18)
Reaction:	OFF2
Acknowledge:	IMMEDIATELY (POWER ON)
Cause:	An incorrect shutoff valve configuration was detected. Fault value (r0949, interpret decimal): 100: Enable Safety Integrated (p9601/p9801), but p0218.0 = 0 (shutoff valve not available). 101: The manipulated variable inhibit time is set less than the wait time to evaluate the feedback signal contacts when switching on the shutoff valve (p0230 < p9625[0]/p9825[0]). 102: The manipulated variable inhibit time is set less than the wait time to evaluate the feedback signal contacts when switching off the shutoff valve (p0230 < p9625[1]/p9825[1]).
Remedy:	For fault value = 100: Check the enable of Safety Integrated and the shutoff valve (p9601/p9801, p0218.0). For fault value = 101: Set the manipulated variable inhibit time higher than the wait time to evaluate the feedback signal contacts when switching on the shutoff valve (p0230 > p9625[0]/p9825[0]). For fault value = 102: Set the manipulated variable inhibit time higher than the wait time to evaluate the feedback signal contacts when switching off the shutoff valve (p0230 > p9625[1]/p9825[1]).

F07800	Drive: No power unit present
Message class:	Error in the parameterization / configuration / commissioning procedure (18)
Reaction:	NONE
Acknowledge:	IMMEDIATELY
Cause:	The power unit parameters cannot be read or no parameters are stored in the power unit. Note: This fault also occurs if an incorrect topology was selected in the commissioning software and this parameterization is then downloaded to the Control Unit. See also: r0200 (Power unit code number actual)
Remedy:	- carry out a POWER ON (switch-off/switch-on) for all components. - check the power unit and replace if necessary. - check the Control Unit, and if required replace it. - after correcting the topology, the parameters must be again downloaded using the commissioning software.

F07801	Drive: Motor overcurrent
Message class:	Motor overload (8)
Reaction:	OFF2 (NONE, OFF1, OFF3)
Acknowledge:	IMMEDIATELY

Cause:	The permissible motor limit current was exceeded. <ul style="list-style-type: none">- effective current limit set too low.- current controller not correctly set.- <i>U/f</i> operation: Up ramp was set too short or the load is too high.- <i>U/f</i> operation: Short-circuit in the motor cable or ground fault.- <i>U/f</i> operation: Motor current does not match current of power unit.- Switch to rotating motor without flying restart function (p1200).
Remedy:	Note: Limit current = 2 x minimum (p0640, 4 x p0305 x p0306) >= 2 x p0305 x p0306 <ul style="list-style-type: none">- check the current limits (p0640).- vector control: Check the current controller (p1715, p1717).- <i>U/f</i> control: Check the current limiting controller (p1340 ... p1346).- increase the up ramp (p1120) or reduce the load.- check the motor and motor cables for short-circuit and ground fault.- check the motor for the star-delta configuration and rating plate parameterization.- check the power unit and motor combination.- Choose "flying restart" function (p1200) if switched to rotating motor.

F07802	Drive: Infeed or power unit not ready
Message class:	Infeed faulted (13)
Reaction:	OFF2 (NONE)
Acknowledge:	IMMEDIATELY
Cause:	After an internal switch-on command, the infeed or drive does not signal ready. <ul style="list-style-type: none">- monitoring time is too short.- DC link voltage is not present.- associated infeed or drive of the signaling component is defective.- supply voltage incorrectly set.
Remedy:	<ul style="list-style-type: none">- increase the monitoring time (p0857).- ensure that there is a DC link voltage. Check the DC link busbar. Enable the infeed.- replace the associated infeed or drive of the signaling component.- check the line supply voltage setting (p0210). See also: p0857 (Power unit monitoring time)

A07805 (N)	Drive: Power unit overload I2t
Message class:	Power electronics faulted (5)
Reaction:	NONE
Acknowledge:	NONE
Cause:	Alarm threshold for I2t overload (p0294) of the power unit exceeded. The response parameterized in p0290 becomes active. See also: p0290 (Power unit overload response)
Remedy:	<ul style="list-style-type: none">- reduce the continuous load.- adapt the load duty cycle.- check the assignment of the motor and power unit rated currents.

F07807	Drive: Short-circuit/ground fault detected
Message class:	Ground fault / inter-phase short-circuit detected (7)
Reaction:	OFF2 (NONE)
Acknowledge:	IMMEDIATELY

4 Faults and alarms

4.2 List of faults and alarms

Cause:	<p>A phase-phase short-circuit or ground fault was detected at the motor-side output terminals of the converter.</p> <p>Fault value (r0949, interpret decimal):</p> <ul style="list-style-type: none">1: Short-circuit, phase UV.2: Short-circuit, phase UW.3: Short-circuit, phase VW.4: Ground fault with overcurrent.5: Motor cable phase U interrupted6: Motor cable phase V interrupted7: Motor cable phase W interrupted8: Short-circuit with hardware shutdown <p>1yxxx: Ground fault with current in phase U detected (y = pulse number, xxxx = component of the current in phase U in per mille).</p> <p>2yxxx: Ground fault with current in phase V detected (y = pulse number, xxxx = component of the current in phase U in per mille).</p> <p>Note:</p> <p>Also when interchanging the line and motor cables is identified as a motor-side short circuit.</p> <p>The ground fault test only functions when the motor is stationary.</p> <p>Connecting to a motor that is either not de-energized or partially de-energized is possibly detected as ground fault.</p>
Remedy:	<ul style="list-style-type: none">- check the motor-side converter connection for a phase-phase short-circuit.- rule-out interchanged line and motor cables.- check for a ground fault.- check the motor cable connections <p>For a ground fault the following applies:</p> <ul style="list-style-type: none">- do not enable the pulses when connecting to a rotating motor without the "Flying restart" function activated (p1200).- increase the de-energization time (p0347).- increase pulse cancellation delay time (p1228) to ensure standstill.- if required, deactivate the monitoring (p1901).

F07810	Drive: Power unit EEPROM without rated data
Message class:	Hardware/software error (1)
Reaction:	NONE
Acknowledge:	IMMEDIATELY
Cause:	<p>No rated data are stored in the power unit EEPROM.</p> <p>See also: p0205 (Power unit application), r0206 (Rated power unit power), r0207 (Rated power unit current), r0208 (Rated power unit line supply voltage), r0209 (Power unit maximum current)</p>
Remedy:	Replace the power unit or inform Siemens Customer Service.

A07850 (F)	External alarm 1
Message class:	External measured value / signal state outside the permissible range (16)
Reaction:	NONE
Acknowledge:	NONE
Cause:	<p>The condition for "External alarm 1" is satisfied.</p> <p>Note:</p> <p>The "External alarm 1" is initiated by a 1/0 edge via binector input p2112.</p> <p>See also: p2112 (External alarm 1)</p>
Remedy:	Eliminate the causes of this alarm.

A07851 (F)	External alarm 2
Message class:	External measured value / signal state outside the permissible range (16)
Reaction:	NONE
Acknowledge:	NONE
Cause:	<p>The condition for "External alarm 2" is satisfied.</p> <p>Note:</p> <p>The "External alarm 2" is initiated by a 1/0 edge via binector input p2116.</p> <p>See also: p2116 (External alarm 2)</p>
Remedy:	Eliminate the causes of this alarm.

A07852 (F)	External alarm 3
Message class:	External measured value / signal state outside the permissible range (16)
Reaction:	NONE
Acknowledge:	NONE
Cause:	The condition for "External alarm 3" is satisfied. Note: The "External alarm 3" is initiated by a 1/0 edge via binector input p2117. See also: p2117 (External alarm 3)
Remedy:	Eliminate the causes of this alarm.

F07860 (A)	External fault 1
Message class:	External measured value / signal state outside the permissible range (16)
Reaction:	OFF2 (IASC/DCBRK, NONE, OFF1, OFF3, STOP2)
Acknowledge:	IMMEDIATELY (POWER ON)
Cause:	The condition for "External fault 1" is satisfied. Note: The "External fault 1" is initiated by a 1/0 edge via binector input p2106. See also: p2106 (External fault 1)
Remedy:	- eliminate the causes of this fault. - acknowledge fault.

F07861 (A)	External fault 2
Message class:	External measured value / signal state outside the permissible range (16)
Reaction:	OFF2 (IASC/DCBRK, NONE, OFF1, OFF3, STOP2)
Acknowledge:	IMMEDIATELY (POWER ON)
Cause:	The condition for "External fault 2" is satisfied. Note: The "External fault 2" is initiated by a 1/0 edge via binector input p2107. See also: p2107 (External fault 2)
Remedy:	- eliminate the causes of this fault. - acknowledge fault.

F07862 (A)	External fault 3
Message class:	External measured value / signal state outside the permissible range (16)
Reaction:	OFF2 (IASC/DCBRK, NONE, OFF1, OFF3, STOP2)
Acknowledge:	IMMEDIATELY (POWER ON)
Cause:	The condition for "External fault 3" is satisfied. Note: The "External fault 3" is initiated by a 1/0 edge via the following parameters. - AND logic operation, binector input p2108, p3111, p3112. - switch-on delay p3110. See also: p2108 (External fault 3), p3110 (External fault 3 switch-on delay), p3111 (External fault 3 enable), p3112 (External fault 3 enable negated)
Remedy:	- eliminate the causes of this fault. - acknowledge fault.

A07891	Drive: Load monitoring pump/fan blocked
Message class:	Motor overload (8)
Reaction:	NONE
Acknowledge:	NONE
Cause:	The load monitoring is configured for a pump or fan (p2193 = 4, 5). The monitoring function detects when the pump/fan is blocked. It is possible that the blocking torque threshold (p2168) is set too low (e.g. heavy duty starting). See also: p2165 (Load monitoring stall monitoring upper threshold), p2168 (Load monitoring stall monitoring torque threshold), p2181 (Load monitoring response), p2193 (Load monitoring configuration)

- Remedy:**
- check whether the pump/fan is blocked, and if blocked, then resolve the problem.
 - check that the fan can freely move, and if necessary, resolve the problem.
 - adapt the parameterization corresponding to the load (p2165, p2168)..

A07892	Drive: Load monitoring pump/fan no load condition
Message class:	Application/technological function faulted (17)
Reaction:	NONE
Acknowledge:	NONE
Cause:	The load monitoring is configured for a pump or fan (p2193 = 4, 5). The monitoring function detects when the pump/fan is operating under no load conditions. The pump is running in the dry state (no medium to be pumped) – or the fan has a broken belt. It is possible that the detection torque threshold is too low (p2191). See also: p2181 (Load monitoring response), p2191 (Load monitoring torque threshold no load), p2193 (Load monitoring configuration)
Remedy:	- for a pump, check the medium being pumped, and if required, provide the medium. - for a fan, check the belt, and if required, replace. - if necessary, increase the detection torque threshold (p2191).

A07893	Drive: Load monitoring pump leakage
Message class:	Application/technological function faulted (17)
Reaction:	NONE
Acknowledge:	NONE
Cause:	The load monitoring is configured for a pump (p2193 = 4). The monitoring function detects a leak in the pump circuit. In this case, the pump requires a torque that is lower than in normal operation to pump the reduced quantity. See also: p2181, p2182, p2183, p2184, p2186, p2188, p2190, p2193
Remedy:	- remove the leak in the pump circuit. - for a nuisance trip, reduce the torque thresholds of the leakage characteristic (p2186, p2188, p2190).

F07894	Drive: Load monitoring pump/fan blocked
Message class:	Motor overload (8)
Reaction:	OFF1 (NONE, OFF2, OFF3)
Acknowledge:	IMMEDIATELY
Cause:	The load monitoring is configured for a pump or fan (p2193 = 4, 5). The monitoring function detects when the pump/fan is blocked. It is possible that the blocking torque threshold (p2168) is set too low (e.g. heavy duty starting). See also: p2165 (Load monitoring stall monitoring upper threshold), p2168 (Load monitoring stall monitoring torque threshold), p2181 (Load monitoring response), p2193 (Load monitoring configuration)
Remedy:	- check whether the pump/fan is blocked, and if blocked, then resolve the problem. - check that the fan can freely move, and if necessary, resolve the problem. - adapt the parameterization corresponding to the load (p2165, p2168)..

F07895	Drive: Load monitoring pump/fan no load condition
Message class:	Application/technological function faulted (17)
Reaction:	OFF1 (NONE, OFF2, OFF3)
Acknowledge:	IMMEDIATELY
Cause:	The load monitoring is configured for a pump or fan (p2193 = 4, 5). The monitoring function detects when the pump/fan is operating under no load conditions. The pump is running in the dry state (no medium to be pumped) – or the fan has a broken belt. It is possible that the detection torque threshold is too low (p2191). See also: p2181 (Load monitoring response), p2191 (Load monitoring torque threshold no load), p2193 (Load monitoring configuration)
Remedy:	- for a pump, check the medium being pumped, and if required, provide the medium. - for a fan, check the belt, and if required, replace. - if necessary, increase the detection torque threshold (p2191).

F07896	Drive: Load monitoring pump leakage
Message class:	Application/technological function faulted (17)
Reaction:	OFF1 (NONE, OFF2, OFF3)
Acknowledge:	IMMEDIATELY
Cause:	The load monitoring is configured for a pump (p2193 = 4). The monitoring function detects a leak in the pump circuit. In this case, the pump requires a torque that is lower than in normal operation to pump the reduced quantity. See also: p2181, p2182, p2183, p2184, p2186, p2188, p2190, p2193
Remedy:	- remove the leak in the pump circuit. - for a nuisance trip, reduce the torque thresholds of the leakage characteristic (p2186, p2188, p2190).

F07900 (N, A)	Drive: Motor blocked
Message class:	Application/technological function faulted (17)
Reaction:	OFF2 (NONE, OFF1, OFF3, STOP2)
Acknowledge:	IMMEDIATELY
Cause:	Motor has been operating at the torque limit longer than the time specified in p2177 and below the speed threshold set in p2175. This signal can also be triggered if the speed is oscillating and the speed controller output repeatedly goes to its limit. It may also be the case that thermal monitoring of the power unit reduces the current limit (see p0290), thereby causing the motor to decelerate. See also: p2175 (Motor blocked speed threshold), p2177 (Motor blocked delay time)
Remedy:	- check that the motor can freely move. - check the effective torque limit (r1538, r1539). - check the parameter, message "Motor blocked" and if required, correct (p2175, p2177). - check the direction of rotation enable signals for a flying restart of the motor (p1110, p1111). - for U/f control: check the current limits and acceleration times (p0640, p1120).

F07901	Drive: Motor overspeed
Message class:	Application/technological function faulted (17)
Reaction:	OFF2 (IASC/DCBRK)
Acknowledge:	IMMEDIATELY
Cause:	The maximum permissible speed was either positively or negatively exceeded. The maximum permissible positive speed is formed as follows: Minimum (p1082, CI: p1085) + p2162 The maximum permissible negative speed is formed as follows: Maximum (-p1082, CI: 1088) - p2162
Remedy:	The following applies for a positive direction of rotation: - check r1084 and if required, correct p1082, CI:p1085 and p2162. The following applies for a negative direction of rotation: - check r1087 and if required, correct p1082, CI:p1088 and p2162. Activate precontrol of the speed limiting controller (p1401.7 = 1). Increase the hysteresis for the overspeed signal p2162. This upper limit is dependent upon the maximum motor speed p0322 and the maximum speed p1082 of the setpoint channel.

F07902 (N, A)	Drive: Motor stalled
Message class:	Application/technological function faulted (17)
Reaction:	OFF2 (IASC/DCBRK, NONE, OFF1, OFF3, STOP2)
Acknowledge:	IMMEDIATELY
Cause:	The system has identified that the motor has stalled for a time longer than is set in p2178. Fault value (r0949, interpret decimal): 1: Reserved. 2: Stall detection using r1408.12 (p1745) or via (r0084 ... r0083). See also: p2178 (Motor stalled delay time)

Remedy: Steps should always be taken to ensure that both motor data identification and the rotating measurement were (if possible) carried out (see p1900, r3925).

- Check whether the drive is in the open-loop speed control operating range (see p1755), or if the speed setpoint is still zero, whether the load alone caused the drive to stall. If yes, increase ramp-up time p1120, increase ramp-down time p1121 and increase current setpoint via p1610, p1611.
- If the excitation time (p0346) of the induction motor was significantly reduced and the drive stalls when it is switched on and immediately run, then p0346 should be increased again.
- Check whether the power unit is experiencing a line phase failure.
- check whether the motor cables are disconnected (see A07929).

If there is no fault, then the fault tolerance (p1745) or the delay time (p2178) can be increased.

- check the current limits (p0640, r0067, r0289). If the current limits are too low, then the drive cannot be magnetized.
- if the fault occurs with fault value 2 when the motor accelerates very quickly to the field weakening range, the deviation between the flux setpoint and flux actual value can be reduced and, in turn, the message prevented, by reducing p1596 or p1553.

A07903 Drive: Motor speed deviation

Message class: Application/technological function faulted (17)

Reaction: NONE

Acknowledge: NONE

Cause: The absolute value of the speed difference from the setpoint (p2151) and the speed actual value (r2169) exceeds the tolerance threshold (p2163) longer than tolerated (p2164, p2166).
The alarm is only enabled for p2149.0 = 1.
Possible causes:

- the load torque is greater than the torque setpoint.
- when accelerating, the torque/current/power limit is reached. If the limits are not sufficient, then it is possible that the drive has been dimensioned too small.
- for closed-loop torque control, the speed setpoint does not track the speed actual value.
- for active Vdc controller.

For U/f control, the overload condition is detected as the I_max controller is active.
See also: p2149 (Monitoring configuration)

Remedy:

- increase p2163 and/or p2166.
- increase the torque/current/power limits.
- for closed-loop torque control: The speed setpoint should track the speed actual value.
- deactivate alarm with p2149.0 = 0.

A07910 (N) Drive: Motor overtemperature

Message class: Motor overload (8)

Reaction: NONE

Acknowledge: NONE

Cause: KTY84/PT1000 or no sensor:
The measured motor temperature or the temperature of the motor temperature model 2 has exceeded the alarm threshold (p0604). The response parameterized in p0610 becomes active.
PTC or bimetallic NC contact:
The response threshold of 1650 Ohm was exceeded or the NC contact opened.
Alarm value (r2124, interpret decimal):
11: No output current reduction.
12: Output current reduction active.
See also: p0604 (Mot_temp_mod 2/sensor alarm threshold), p0610 (Motor overtemperature response)

Remedy:

- check the motor load.
- check the motor ambient temperature.
- check KTY84/PT1000.
- check overtemperatures of the motor temperature model 2 (p0626 ... p0628).

See also: p0612 (Mot_temp_mod activation), p0625 (Motor ambient temperature during commissioning), p0626 (Motor overtemperature, stator core), p0627 (Motor overtemperature, stator winding), p0628 (Motor overtemperature rotor)

A07920 Drive: Torque/speed too low

Message class: Application/technological function faulted (17)
Reaction: NONE
Acknowledge: NONE
Cause: For p2193 = 1:
The torque deviates from the torque/speed envelope characteristic (too low).
For p2193 = 2:
The speed signal from the external encoder (refer to p3230) deviates from the speed (r2169) (too low).
See also: p2181 (Load monitoring response)
Remedy: - check the connection between the motor and load.
- adapt the parameterization corresponding to the load.

A07921 Drive: Torque/speed too high

Message class: Application/technological function faulted (17)
Reaction: NONE
Acknowledge: NONE
Cause: For p2193 = 1:
The torque deviates from the torque/speed envelope characteristic (too high).
For p2193 = 2:
The speed signal from the external encoder (refer to p3230) deviates from the speed (r2169) (too high).
Remedy: - check the connection between the motor and load.
- adapt the parameterization corresponding to the load.

A07922 Drive: Torque/speed out of tolerance

Message class: Application/technological function faulted (17)
Reaction: NONE
Acknowledge: NONE
Cause: For p2193 = 1:
The torque deviates from the torque/speed envelope characteristic.
For p2193 = 2:
The speed signal from the external encoder (refer to p3230) deviates from the speed (r2169).
Remedy: - check the connection between the motor and load.
- adapt the parameterization corresponding to the load.

F07923 Drive: Torque/speed too low

Message class: Application/technological function faulted (17)
Reaction: OFF1 (NONE, OFF2, OFF3)
Acknowledge: IMMEDIATELY
Cause: For p2193 = 1:
The torque deviates from the torque/speed envelope characteristic (too low).
For p2193 = 2:
The speed signal from the external encoder (refer to p3230) deviates from the speed (r2169) (too low).
Remedy: - check the connection between the motor and load.
- adapt the parameterization corresponding to the load.

F07924 Drive: Torque/speed too high

Message class: Application/technological function faulted (17)
Reaction: OFF1 (NONE, OFF2, OFF3)
Acknowledge: IMMEDIATELY
Cause: For p2193 = 1:
The torque deviates from the torque/speed envelope characteristic (too high).
For p2193 = 2:
The speed signal from the external encoder (refer to p3230) deviates from the speed (r2169) (too high).
Remedy: - check the connection between the motor and load.
- adapt the parameterization corresponding to the load.

F07925	Drive: Torque/speed out of tolerance
Message class:	Application/technological function faulted (17)
Reaction:	OFF1 (NONE, OFF2, OFF3)
Acknowledge:	IMMEDIATELY
Cause:	For p2193 = 1: The torque deviates from the torque/speed envelope characteristic. For p2193 = 2: The speed signal from the external encoder (refer to p3230) deviates from the speed (r2169).
Remedy:	- check the connection between the motor and load. - adapt the parameterization corresponding to the load.

A07926	Drive: Envelope curve parameter invalid
Message class:	Error in the parameterization / configuration / commissioning procedure (18)
Reaction:	NONE
Acknowledge:	NONE
Cause:	Invalid parameter values were entered for the envelope characteristic of the load monitoring. The following rules apply for the speed thresholds: p2182 < p2183 < p2184 The following rules apply for the torque thresholds: p2185 > p2186 p2187 > p2188 p2189 > p2190 Load monitoring configuration and response must match. It is not permissible that the individual load torque monitoring areas overlap. Alarm value (r2124, interpret decimal): Number of the parameter with the invalid value. The load torque monitoring has not been activated as long as the alarm is active.
Remedy:	- set the parameters for the load monitoring according to the applicable rules. - if necessary, deactivate the load monitoring (p2181 = 0, p2193 = 0).

A07927	DC braking active
Message class:	Application/technological function faulted (17)
Reaction:	NONE
Acknowledge:	NONE
Cause:	The motor is braked with DC current. DC braking is active. 1) A message with response DCBRK is active. The motor is braked with the braking current set in p1232 for the duration set in p1233. If the standstill threshold p1226 is undershot, then braking is prematurely canceled. 2) DC braking has been activated at binector input p1230 with the DC braking set (p1230 = 4). Braking current p1232 is injected until this binector input becomes inactive.
Remedy:	Not necessary. The alarm automatically disappears once DC braking has been executed.

A07929 (F)	Drive: No motor detected
Message class:	Application/technological function faulted (17)
Reaction:	NONE
Acknowledge:	NONE
Cause:	The absolute current value is so small after enabling the inverter pulses that no motor is detected. Note: - in the case of vector control and an induction motor, this alarm is followed by fault F07902. See also: p2179 (Output load identification current limit)

Remedy:

- check the motor feeder cables.
- reduce the threshold value (p2179), e.g. for synchronous motors.
- check the voltage boost of the U/f control (p1310).
- carry out a standstill measurement to set the stator resistance (p0350).

F07936

Drive: load failure

Message class: Application/technological function faulted (17)
Reaction: OFF1 (NONE, OFF2, OFF3)
Acknowledge: IMMEDIATELY
Cause: The load monitoring has detected a load failure.
Remedy:

- check the sensor.
- if necessary, deactivate the load monitoring (p2193).

See also: p2193 (Load monitoring configuration), p3232 (Load monitoring failure detection)

F07950 (A)

Motor parameter incorrect

Message class: Error in the parameterization / configuration / commissioning procedure (18)
Reaction: NONE
Acknowledge: IMMEDIATELY
Cause: The motor parameters were incorrectly entered while commissioning (e.g. p0300 = 0, no motor)
 Fault value (r0949, interpret decimal):
 Parameter number involved.
 See also: p0300, p0301, p0304, p0305, p0307, p0310, p0311, p0314, p0316, p0320, p0322, p0323
Remedy: Compare the motor data with the rating plate data and if required, correct.

A07960

Drive: Incorrect friction characteristic

Message class: Error in the parameterization / configuration / commissioning procedure (18)
Reaction: NONE
Acknowledge: NONE
Cause: The friction characteristic is incorrect.
 Alarm value (r2124, interpret decimal):
 1538:
 The friction torque is greater than the maximum from the upper effective torque limit (p1538) and zero. This is the reason that the output of the friction characteristic (r3841) is limited to this value.
 1539:
 The friction torque is less than the minimum from the lower effective torque limit (p1539) and zero. This is the reason that the output of the friction characteristic (r3841) is limited to this value.
 3820 ... 3829:
 Incorrect parameter number. The speeds entered in the parameters for the friction characteristic do not correspond to the following condition:
 $0.0 < p3820 < p3821 < \dots < p3829 \leq p0322$ or $p1082$, if $p0322 = 0$
 Therefore the output of the friction characteristic (r3841) is set to zero.
 3830 ... 3839:
 Incorrect parameter number. The torques entered in the parameters for the friction characteristic do not correspond to the following condition:
 $0 \leq p3830, p3831 \dots p3839 \leq p0333$
 Therefore the output of the friction characteristic (r3841) is set to zero.
 See also: r3840 (Friction characteristic status word)
Remedy: Fulfill the conditions for the friction characteristic.
 For alarm value = 1538:
 Check the upper effective torque limit (e.g. in the field weakening range).
 For alarm value = 1539:
 Check the lower effective torque limit (e.g. in the field weakening range).
 For alarm value = 3820 ... 3839:
 Fulfill the conditions to set the parameters of the friction characteristic.
 If the motor data (e.g. the maximum speed p0322) are changed during commissioning ($p0010 = 1, 3$), then the technological limits and threshold values, dependent on this, must be re-calculated by selecting $p0340 = 5$.

A07961	Drive: Friction characteristic record activated
Message class:	Error in the parameterization / configuration / commissioning procedure (18)
Reaction:	NONE
Acknowledge:	NONE
Cause:	The automatic friction characteristic record is activated. The friction characteristic is recorded at the next switch-on command. When plotting the friction characteristic, it is not possible to save the parameters (p0971, p0977).
Remedy:	Not necessary. The alarm disappears automatically after the friction characteristic record has been successfully completed or the record is deactivated (p3845 = 0).

F07963	Drive: Friction characteristic record interrupted
Message class:	Error in the parameterization / configuration / commissioning procedure (18)
Reaction:	OFF1
Acknowledge:	IMMEDIATELY
Cause:	The conditions to record the friction characteristic are not fulfilled. Fault value (r0949, interpret decimal): 0046: Missing enable signals (r0046). 1082: The highest speed value to be approached (p3829) is greater than the maximum speed (p1082). 1084: The highest speed value to be approached (p3829) is greater than the maximum speed (r1084, p1083, p1085). 1087: The highest speed value to be approached (p3829) is greater than the maximum speed (r1087, p1086, p1088). 1110: Friction characteristic record, negative direction selected (p3845) and negative direction inhibited (p1110). 1111: Friction characteristic record, positive direction selected (p3845) and positive direction inhibited (p1111). 1198: Friction characteristic record selected (p3845 > 0) and negative (p1110) and positive directions (p1111) inhibited (r1198). 1300: The control mode (p1300) has not been set to closed-loop speed control. 1755: For encoderless closed-loop control (p1300 = 20), the lowest speed value to be approached (p3820) is less than or equal to the changeover speed, open-loop controlled operation (p1755). 1910: Motor data identification activated. 1960: Speed controller optimization activated. 3820 ... 3829: speed (p382x) cannot be approached. 3840: Friction characteristic incorrect. 3845: Friction characteristic record de-selected.

Remedy:

Fulfill the conditions to record the friction characteristic.

For fault value = 0046:
- establish missing enable signals.

For fault value = 1082, 1084, 1087:
- Select the highest speed value to be approached (p3829) less than or equal to the maximum speed (p1082, r1084, r1087).
- Re-calculate the speed points along the friction characteristic (p0340 = 5).

For fault value = 1110:
- Select the friction characteristic record, positive direction (p3845).

For fault value = 1111:
- Select the friction characteristic record, negative direction (p3845).

For fault value = 1198:
- Enable the permitted direction (p1110, p1111, r1198).

For fault value = 1300:
- set the control mode (p1300) on the closed-loop speed control (p1300 = 20, 21).

For fault value = 1755:
- For encoderless closed-loop speed control (p1300 = 20) select the lowest speed value to be approached (p3820) greater than the changeover speed of open-loop controlled operation (p1755).
- Re-calculate the speed points along the friction characteristic (p0340 = 5).

For fault value = 1910:
- Exit the motor data identification routine (p1910).

For fault value = 1960:
- Exit the speed controller optimization routine (p1960).

For fault value 3820 ... 3829:
- check the load at speed p382x.
- check the speed signal (r0063) for oscillation at speed p382x. Check the settings of the speed controller if applicable.

For fault value = 3840:
- Make the friction characteristic error-free (p3820 ... p3829, p3830 ... p3839, p3840).

For fault value = 3845:
- Activate the friction characteristic record (p3845).

F07967 **Drive: Incorrect pole position identification**

Message class: Error in the parameterization / configuration / commissioning procedure (18)

Reaction: OFF2 (NONE, OFF1)

Acknowledge: IMMEDIATELY

Cause: A fault has occurred during the pole position identification routine.
Only for internal Siemens troubleshooting.

Remedy: Carry out a POWER ON.

F07968 **Drive: Lq-Ld measurement incorrect**

Message class: Error in the parameterization / configuration / commissioning procedure (18)

Reaction: OFF2

Acknowledge: IMMEDIATELY

Cause: A fault has occurred during the Lq-Ld measurement.
Fault value (r0949, interpret decimal):
10: Stage 1: The ratio between the measured current and zero current is too low.
12: Stage 1: The maximum current was exceeded.
15: Second harmonic too low.
16: Drive converter too small for the measuring technique.
17: Abort due to pulse inhibit.

4.2 List of faults and alarms

Remedy:

- For fault value = 10:
 - Check whether the motor is correctly connected.
 - Replace the power unit involved.
 - Deactivate technique (p1909).
- For fault value = 12:
 - Check whether motor data have been correctly entered.
 - Deactivate technique (p1909).
- For fault value = 16:
 - Deactivate technique (p1909).
- For fault value = 17:
 - Repeat technique.

F07969**Drive: Incorrect pole position identification**

Message class: Error in the parameterization / configuration / commissioning procedure (18)

Reaction: OFF2

Acknowledge: IMMEDIATELY

Cause: A fault has occurred during the pole position identification routine.

Fault value (r0949, interpret decimal):

1: Current controller limited

2: Motor shaft locked.

10: Stage 1: The ratio between the measured current and zero current is too low.

11: Stage 2: The ratio between the measured current and zero current is too low.

12: Stage 1: The maximum current was exceeded.

13: Stage 2: The maximum current was exceeded.

14: Current difference to determine the +d axis too low.

15: Second harmonic too low.

16: Drive converter too small for the measuring technique.

17: Abort due to pulse inhibit.

18: First harmonic too low.

20: Pole position identification requested with the motor shaft rotating and activated "flying restart" function.

Remedy:

For fault value = 1:
Check whether the motor is correctly connected.
Check whether motor data have been correctly entered.
Replace the power unit involved.

For fault value = 2:
Bring the motor into a no-load condition.

For fault value = 10:
When selecting p1980 = 4: Increase the value for p0325.
When selecting p1980 = 1: Increase the value for p0329.
Check whether the motor is correctly connected.
Replace the power unit involved.

For fault value = 11:
Increase the value for p0329.
Check whether the motor is correctly connected.
Replace the power unit involved.

For fault value = 12:
When selecting p1980 = 4: Reduce the value for p0325.
When selecting p1980 = 1: Reduce the value for p0329.
Check whether motor data have been correctly entered.

For fault value = 13:
Reduce the value for p0329.
Check whether motor data have been correctly entered.

For fault value = 14:
Increase the value for p0329.

For fault value = 15:
Increase the value for p0325.
Motor not sufficiently anisotropic, change the technique (p1980 = 1, 10).

For fault value = 16:
Change the technique (p1980).

For fault value = 17:
Repeat technique.

For fault value = 18:
Increase the value for p0329 (if required, first set p0323).
Saturation not sufficient, change the technique (p1980 = 10).

For fault value = 20:
Before carrying out a pole position identification routine ensure that the motor shaft is absolutely stationary (zero speed).

A07980 Drive: Rotating measurement activated

Message class: Error in the parameterization / configuration / commissioning procedure (18)

Reaction: NONE

Acknowledge: NONE

Cause: The rotating measurement (automatic speed controller optimization) is activated.
The rotating measurement is carried out at the next switch-on command.

Note:

During the rotating measurement it is not possible to save the parameters (p0971).

See also: p1960 (Rotating measurement selection)

Remedy: Not necessary.

The alarm disappears automatically after the speed controller optimization has been successfully completed or for the setting p1900 = 0.

A07981 Drive: Enable signals for the rotating measurement missing

Message class: Error in the parameterization / configuration / commissioning procedure (18)

Reaction: NONE

Acknowledge: NONE

Cause: The rotating measurement cannot be started due to missing enable signals.
For p1959.13 = 1, the following applies:
- enable signals for the ramp-function generator missing (see p1140 ... p1142).
- enable signals for the speed controller integrator missing (see p1476, p1477).

Remedy:
- acknowledge faults that are present.
- establish missing enable signals.
See also: r0002 (Drive operating display), r0046 (Missing enable signal)

F07983**Drive: Rotating measurement saturation characteristic**

Message class: Error in the parameterization / configuration / commissioning procedure (18)

Reaction: OFF1 (NONE, OFF2)

Acknowledge: IMMEDIATELY

Cause: A fault has occurred while determining the saturation characteristic.

Fault value (r0949, interpret decimal):

- 1: The speed did not reach a steady-state condition.
- 2: The rotor flux did not reach a steady-state condition.
- 3: The adaptation circuit did not reach a steady-state condition.
- 4: The adaptation circuit was not enabled.
- 5: Field weakening active.
- 6: The speed setpoint was not able to be approached as the minimum limiting is active.
- 7: The speed setpoint was not able to be approached as the suppression (skip) bandwidth is active.
- 8: The speed setpoint was not able to be approached as the maximum limiting is active.
- 9: Several values of the determined saturation characteristic are not plausible.
- 10: Saturation characteristic could not be sensibly determined because load torque too high.

Remedy:

For fault value = 1:

- the total drive moment of inertia is far higher than that of the motor (p0341, p0342).

De-select rotating measurement (p1960), enter the moment of inertia p0342, re-calculate the speed controller p0340 = 4 and repeat the measurement.

For fault value = 1 ... 2:

- increase the measuring speed (p1961) and repeat the measurement.

For fault value = 1 ... 4:

- check the motor parameters (rating plate data). After the change: Calculate p0340 = 3.
- check the moment of inertia (p0341, p0342). After the change: Calculate p0340 = 3.
- carry out a motor data identification routine (p1910).
- if required, reduce the dynamic factor (p1967 < 25 %).

For fault value = 5:

- the speed setpoint (p1961) is too high. Reduce the speed.

For fault value = 6:

- adapt the speed setpoint (p1961) or minimum limiting (p1080).

For fault value = 7:

- adapt the speed setpoint (p1961) or suppression (skip) bandwidths (p1091 ... p1094, p1101).

For fault value = 8:

- adapt the speed setpoint (p1961) or maximum limit (p1082, p1083 and p1086).

For fault value = 9, 10:

- the measurement was carried out at an operating point where the load torque is too high. Select a more suitable operating point, either by changing the speed setpoint (p1961) or by reducing the load torque. The load torque may not be varied while making measurements.

Note:

The saturation characteristic identification routine can be disabled using p1959.1.

See also: p1959 (Rotating measurement configuration)

F07984**Drive: Speed controller optimization, moment of inertia**

Message class: Error in the parameterization / configuration / commissioning procedure (18)

Reaction: OFF1 (NONE, OFF2)

Acknowledge: IMMEDIATELY

Cause:	<p>A fault has occurred while identifying the moment of inertia.</p> <p>Fault value (r0949, interpret decimal):</p> <ol style="list-style-type: none">1: The speed did not reach a steady-state condition.2: The speed setpoint was not able to be approached as the minimum limiting is active.3: The speed setpoint was not able to be approached as the suppression (skip) bandwidth is active.4: The speed setpoint was not able to be approached as the maximum limiting is active.5: It is not possible to increase the speed by 10% as the minimum limiting is active.6: It is not possible to increase the speed by 10% as the suppression (skip) bandwidth is active.7: It is not possible to increase the speed by 10% as the maximum limiting is active.8: The torque difference after the speed setpoint step is too low in order to be able to still reliably identify the moment of inertia.9: Too few data to be able to reliably identify the moment of inertia.10: After the setpoint step, the speed either changed too little or in the incorrect direction.11: The identified moment of inertia is not plausible. The measured moment of inertia is less than the 0.1x or greater than 500x the preset moment of inertia of the motor p0341.
Remedy:	<p>For fault value = 1:</p> <ul style="list-style-type: none">- check the motor parameters (rating plate data). After the change: Calculate p0340 = 3.- check the moment of inertia (p0341, p0342). After the change: Calculate p0340 = 3.- carry out a motor data identification routine (p1910).- if required, reduce the dynamic factor (p1967 < 25 %). <p>For fault value = 2, 5:</p> <ul style="list-style-type: none">- adapt the speed setpoint (p1965) or adapt the minimum limit (p1080). <p>For fault value = 3, 6:</p> <ul style="list-style-type: none">- adapt the speed setpoint (p1965) or suppression (skip) bandwidths (p1091 ... p1094, p1101). <p>For fault value = 4, 7:</p> <ul style="list-style-type: none">- adapt the speed setpoint (p1965) or maximum limit (p1082, p1083 and p1086). <p>For fault value = 8:</p> <ul style="list-style-type: none">- the total drive moment of inertia is far higher than that of the motor (refer to p0341, p0342). De-select rotating measurement (p1960), enter the moment of inertia p0342, re-calculate the speed controller p0340 = 4 and repeat the measurement. <p>For fault value = 9:</p> <ul style="list-style-type: none">- check the moment of inertia (p0341, p0342). After the change, re-calculate (p0340 = 3 or 4). <p>For fault value = 10:</p> <ul style="list-style-type: none">- check the moment of inertia (p0341, p0342). After the change: Calculate p0340 = 3. <p>For fault value = 11:</p> <ul style="list-style-type: none">- reduce the moment of inertia of the motor p0341 (e.g. factor of 0.2) or increase (e.g. factor of 5) and repeat the measurement. <p>Note:</p> <p>The moment of inertia identification routine can be disabled using p1959.2. See also: p1959 (Rotating measurement configuration)</p>

F07985	Drive: Speed controller optimization (oscillation test)
Message class:	Error in the parameterization / configuration / commissioning procedure (18)
Reaction:	OFF1 (NONE, OFF2)
Acknowledge:	IMMEDIATELY
Cause:	<p>A fault has occurred during the vibration test.</p> <p>Fault value (r0949, interpret decimal):</p> <ol style="list-style-type: none">1: The speed did not reach a steady-state condition.2: The speed setpoint was not able to be approached as the minimum limiting is active.3: The speed setpoint was not able to be approached as the suppression (skip) bandwidth is active.4: The speed setpoint was not able to be approached as the maximum limiting is active.5: Torque limits too low for a torque step.6: No suitable speed controller setting was found.

Remedy:

For fault value = 1:

- check the motor parameters (rating plate data). After the change: Calculate p0340 = 3.
- check the moment of inertia (p0341, p0342). After the change: Calculate p0340 = 3.
- carry out a motor data identification routine (p1910).
- if required, reduce the dynamic factor (p1967 < 25 %).

For fault value = 2:

- adapt the speed setpoint (p1965) or adapt the minimum limit (p1080).

For fault value = 3:

- adapt the speed setpoint (p1965) or suppression (skip) bandwidths (p1091 ... p1094, p1101).

For fault value = 4:

- adapt the speed setpoint (p1965) or maximum limit (p1082, p1083 and p1086).

For fault value = 5:

- increase the torque limits (e.g. p1520, p1521).

For fault value = 6:

- reduce the dynamic factor (p1967).
- disable the vibration test (p1959.4 = 0) and repeat the rotating measurement.

See also: p1959 (Rotating measurement configuration)

F07986 **Drive: Rotating measurement ramp-function generator**

Message class: Error in the parameterization / configuration / commissioning procedure (18)

Reaction: OFF1 (NONE, OFF2)

Acknowledge: IMMEDIATELY

Cause: During the rotating measurements, problems with the ramp-function generator occurred.
Fault value (r0949, interpret decimal):
1: The positive and negative directions are inhibited.

Remedy: For fault value = 1:
Enable the direction (p1110 or p1111).

F07988 **Drive: Rotating measurement, no configuration selected**

Message class: Error in the parameterization / configuration / commissioning procedure (18)

Reaction: OFF2 (NONE, OFF1)

Acknowledge: IMMEDIATELY

Cause: When configuring the rotating measurement (p1959), no function was selected.

Remedy: Select at least one function for automatic optimization of the speed controller (p1959).
See also: p1959 (Rotating measurement configuration)

F07990 **Drive: Incorrect motor data identification**

Message class: Error in the parameterization / configuration / commissioning procedure (18)

Reaction: OFF2 (NONE, OFF1)

Acknowledge: IMMEDIATELY

Cause:	<p>A fault has occurred during the identification routine.</p> <p>Fault value (r0949, interpret decimal):</p> <p>1: Current limit value reached.</p> <p>2: Identified stator resistance lies outside the expected range 0.1 ... 100% of Zn.</p> <p>3: Identified rotor resistance lies outside the expected range 0.1 ... 100% of Zn.</p> <p>4: identified stator reactance lies outside the expected range 50 ... 500 % of Zn.</p> <p>5: identified magnetizing reactance lies outside the expected range 50 ... 500 % of Zn.</p> <p>6: Identified rotor time constant lies outside the expected range 10 ms ... 5 s.</p> <p>7: identified total leakage reactance lies outside the expected range 4 ... 50 % of Zn.</p> <p>8: Identified stator leakage reactance lies outside the expected range 2 ... 50% of Zn.</p> <p>9: Identified rotor leakage reactance lies outside the expected range 2 ... 50% of Zn.</p> <p>10: Motor has been incorrectly connected.</p> <p>11: Motor shaft rotates.</p> <p>12: Ground fault detected.</p> <p>15: Pulse inhibit occurred during motor data identification.</p> <p>20: Identified threshold voltage of the semiconductor devices lies outside the expected range 0 ... 10 V.</p> <p>30: Current controller in voltage limiting.</p> <p>40: At least one identification contains errors. The identified parameters are not saved to prevent inconsistencies.</p> <p>Note:</p> <p>Percentage values are referred to the rated motor impedance:</p> $Z_n = V_{mot,nom} / \sqrt{3} / I_{mot,nom}$ <p>For fault value = 1 ... 40:</p> <ul style="list-style-type: none"> - check whether motor data have been correctly entered in p0300, p0304 ... p0311. - is there an appropriate relationship between the motor power rating and that of the power unit? The ratio of the power unit to the rated motor current should not be less than 0.5 and not be greater than 4. - check connection type (star-delta). <p>For fault value = 4, 7:</p> <ul style="list-style-type: none"> - check whether the inductance in p0233 is correctly set. - check whether motor has been correctly connected (star-delta). <p>For fault value = 11 in addition:</p> <ul style="list-style-type: none"> - deactivate oscillation monitoring (p1909.7 = 1). <p>For fault value = 12:</p> <ul style="list-style-type: none"> - check the power cable connections. - check the motor. - check the CT.
Remedy:	

A07991 (N)	Drive: Motor data identification activated
Message class:	Error in the parameterization / configuration / commissioning procedure (18)
Reaction:	NONE
Acknowledge:	NONE
Cause:	<p>The motor data identification routine is activated.</p> <p>The motor data identification routine is carried out at the next switch-on command.</p> <p>If rotating measurement is selected (see p1900, p1960), it will not be possible to save the parameter assignment. Once motor data identification has been completed or deactivated, the option to save the parameter assignment will be made available again.</p> <p>See also: p1910 (Motor data identification selection)</p>
Remedy:	<p>Not necessary.</p> <p>The alarm automatically disappears after the motor data identification routine has been successfully completed or for the setting p1900 = 0.</p>

A07994 (F, N)	Drive: motor data identification not performed
Message class:	Error in the parameterization / configuration / commissioning procedure (18)
Reaction:	NONE
Acknowledge:	NONE

4 Faults and alarms

4.2 List of faults and alarms

- Cause:** The "vector control" mode has been selected and a motor data identification has still not been performed.
The alarm is initiated when changing the drive data set (see r0051) in the following cases:
- vector control is parameterized in the actual drive data set (p1300 >= 20).
- and
- motor data identification has still not been performed in the actual drive data set (see r3925).
- Note:**
A check can be made and the alarm output also when exiting commissioning and when the system runs up.
- Remedy:**
- Perform motor data identification (see p1900).
 - if required, parameterize "U/f control" (p1300 < 20).
 - switch over to a drive data set, in which the conditions do not apply.

F08010 (N, A) CU: Analog-to-digital converter

Message class: Hardware/software error (1)

Reaction: OFF1 (IASC/DCBRK, NONE, OFF2, OFF3, STOP2)

Acknowledge: IMMEDIATELY (POWER ON)

Cause: The analog-to-digital converter on the Control Unit has not supplied any converted data.

Remedy:

- check the power supply.
- replace Control Unit.

F08501 (N, A) PROFINET: Setpoint timeout

Message class: Communication error to the higher-level control system (9)

Reaction: OFF3 (IASC/DCBRK, NONE, OFF1, OFF2, STOP2)

Acknowledge: IMMEDIATELY

Cause: The reception of setpoints from PROFINET has been interrupted.

- bus connection interrupted.
- controller switched off.
- controller set into the STOP state.

Remedy:

- Restore the bus connection and set the controller to RUN.
- if the error is repeated, check the update time set in the bus configuration (HW Config).

F08502 (A) PROFINET: Monitoring time sign-of-life expired

Message class: Communication error to the higher-level control system (9)

Reaction: OFF1 (OFF2, OFF3)

Acknowledge: IMMEDIATELY

Cause: The monitoring time for the sign-of-life counter has expired.
The connection to the PROFINET interface was interrupted.

Remedy:

- carry out a POWER ON (switch-off/switch-on).
- contact Technical Support.

A08511 (F) PROFINET: Receive configuration data invalid

Message class: Error in the parameterization / configuration / commissioning procedure (18)

Reaction: NONE

Acknowledge: NONE

Cause: The drive unit did not accept the receive configuration data.
Alarm value (r2124, interpret decimal):
Return value of the receive configuration data check.

2: Too many PZD data words for input or output. The number of possible PZD is specified by the number of indices in r2050/p2051.

3: Uneven number of bytes for input or output.

501: PROFIsafe parameter error (e.g. F_dest).

502: PROFIsafe telegram does not match.

Remedy: Check the receive configuration data.
For alarm value = 2:
- check the number of data words for output and input.
For alarm value = 501:
- check the set PROFIsafe address (p9610).
For alarm value = 502:
Check the enable of F-DI (p9501.30).

A08526 (F) PROFINET: No cyclic connection
Message class: Communication error to the higher-level control system (9)
Reaction: NONE
Acknowledge: NONE
Cause: There is no connection to a PROFINET controller.
Remedy: Establish the cyclic connection and activate the controller with cyclic operation.
Check the parameters "Name of Station" and "IP of Station" (r61000, r61001).

A08564 PN/COMM BOARD: syntax error in the configuration file
Message class: Error in the parameterization / configuration / commissioning procedure (18)
Reaction: NONE
Acknowledge: NONE
Cause: A syntax error has been detected in the ASCII configuration file for the Communication Board Ethernet. The saved configuration file has not been loaded.
Remedy: - correct the PROFINET interface configuration (p8920 and following) and activate (p8925 = 2).
- reinitialize the station (e.g. using the STARTER commissioning software)
Note:
The configuration is not applied until the next POWER ON!
See also: p8925 (Activate PN interface configuration)

A08565 PROFINET: Consistency error affecting adjustable parameters
Message class: Error in the parameterization / configuration / commissioning procedure (18)
Reaction: NONE
Acknowledge: NONE
Cause: A consistency error was detected when activating the configuration (p8925) for the PROFINET interface. The currently set configuration has not been activated.
Alarm value (r2124, interpret decimal):
0: general consistency error
1: error in the IP configuration (IP address, subnet mask or standard gateway)
2: Error in the station names.
3: DHCP was not able to be activated, as a cyclic PROFINET connection already exists.
4: a cyclic PROFINET connection is not possible as DHCP is activated.
See also: p8920 (PN Name of Station), p8921 (PN IP address), p8922 (PN Default Gateway), p8923 (PN Subnet Mask)
Remedy: - check the required interface configuration (p8920 and following), correct if necessary, and activate (p8925).
or
- reconfigure the station via the "Edit Ethernet node" screen form (e.g. with STARTER commissioning software).
See also: p8925 (Activate PN interface configuration)

A08800 PROFlenergy energy-saving mode active
Message class: Communication error to the higher-level control system (9)
Reaction: NONE
Acknowledge: NONE
Cause: The PROFlenergy energy-saving mode is active
Alarm value (r2124, interpret decimal):
Mode ID of the active PROFlenergy energy-saving mode.
See also: r5600 (Pe energy-saving mode ID)

Remedy: The alarm is automatically withdrawn when the energy-saving mode is exited.
Note:
The energy-saving mode is exited after the following events:
- the PROFenergy command end_pause is received from the higher-level control.
- the higher-level control has changed into the STOP operating state.
- the PROFINET connection to the higher-level control has been disconnected.

F13009 Licensing OA application not licensed

Message class: Error in the parameterization / configuration / commissioning procedure (18)
Reaction: OFF1
Acknowledge: IMMEDIATELY
Cause: At least one OA application which is under license does not have a license.
Note:
Refer to r4955 and p4955 for information about the installed OA applications.
Remedy:
- enter and activate the license key for OA applications under license (p9920, p9921).
- if necessary, deactivate unlicensed OA applications (p4956).

F13100 Know-how protection: Copy protection error

Message class: Error in the parameterization / configuration / commissioning procedure (18)
Reaction: OFF1
Acknowledge: IMMEDIATELY
Cause: The know-how protection with copy protection for the memory card is active.
An error has occurred when checking the memory card.
Fault value (r0949, interpret decimal):
0: A memory card is not inserted.
1: An invalid memory card is inserted (not SIEMENS).
2: An invalid memory card is inserted.
3: The memory card is being used in another Control Unit.
12: An invalid memory card is inserted (OEM input incorrect, p7769).
13: The memory card is being used in another Control Unit (OEM input incorrect, p7759).
See also: p7765 (KHP configuration)
Remedy:
For fault value = 0, 1:
- insert the correct memory card and carry out POWER ON.
For fault value = 2, 3, 12, 13:
- contact the responsible OEM.
- Deactivate copy protection (p7765) and acknowledge the fault (p3981).
- Deactivate know-how protection (p7766 ... p7768) and acknowledge the fault (p3981).
Note:
In general, the copy protection can only be changed when know-how protection is deactivated.
KHP: Know-How Protection
See also: p3981 (Acknowledge drive object faults), p7765 (KHP configuration)

F13101 Know-how protection: Copy protection cannot be activated

Message class: Error in the parameterization / configuration / commissioning procedure (18)
Reaction: NONE
Acknowledge: IMMEDIATELY
Cause: An error occurred when attempting to activate the copy protection for the memory card.
Fault value (r0949, interpret decimal):
0: A memory card is not inserted.
1: An invalid memory card is inserted (not SIEMENS).
Note:
KHP: Know-How Protection
Remedy:
- insert a valid memory card.
- Try to activate copy protection again (p7765).
See also: p7765 (KHP configuration)

F13102	Know-how protection: Consistency error of the protected data
Message class:	Error in the parameterization / configuration / commissioning procedure (18)
Reaction:	OFF1
Acknowledge:	IMMEDIATELY
Cause:	An error was identified when checking the consistency of the protected files. As a consequence, the project on the memory card cannot be run. Fault value (r0949, interpret hexadecimal): yyyyxxx hex: yyyy = object number, xxx = fault cause xxx = 1: A file has a checksum error. xxx = 2: The files are not consistent with one another. xxx = 3: The project files, which were loaded into the file system via load (download from the memory card), are inconsistent. Note: KHP: Know-How Protection
Remedy:	<ul style="list-style-type: none">- Replace the project on the memory card or replace project files for download from the memory card.- Restore the factory setting and download again.

F30001	Power unit: Overcurrent
Message class:	Power electronics faulted (5)
Reaction:	OFF2
Acknowledge:	IMMEDIATELY
Cause:	The power unit has detected an overcurrent condition. <ul style="list-style-type: none">- closed-loop control is incorrectly parameterized.- motor has a short-circuit or fault to ground (frame).- <i>U/f</i> operation: Up ramp set too low.- <i>U/f</i> operation: rated current of motor much greater than that of power unit.- High discharge and post-charging current for line supply voltage interruptions.- High post-charging currents for overload when motoring and DC link voltage dip.- short-circuit currents at switch-on due to the missing line reactor.- power cables are not correctly connected.- power cables exceed the maximum permissible length.- power unit defective.- line phase interrupted. Fault value (r0949, interpret bitwise binary): Bit 0: Phase U. Bit 1: Phase V. Bit 2: Phase W. Bit 3: Overcurrent in the DC link. Note: Fault value = 0 means that the phase with overcurrent is not recognized.
Remedy:	<ul style="list-style-type: none">- check the motor data - if required, carry out commissioning.- check the motor circuit configuration (star/delta).- <i>U/f</i> operation: Increase up ramp.- <i>U/f</i> operation: Check assignment of rated currents of motor and power unit.- check the line supply quality.- reduce motor load.- correct connection of line reactor.- check the power cable connections.- check the power cables for short-circuit or ground fault.- check the length of the power cables.- replace power unit.- check the line supply phases.

F30002	Power unit: DC link voltage overvoltage
Message class:	DC link overvoltage (4)
Reaction:	OFF2
Acknowledge:	IMMEDIATELY
Cause:	The power unit has detected an overvoltage condition in the DC link. <ul style="list-style-type: none">- motor regenerates too much energy.- line supply voltage too high.- line phase interrupted.- DC link voltage control switched off.- dynamic response of DC link voltage controller excessive or insufficient. Fault value (r0949, interpret decimal): DC link voltage at the time of trip [0.1 V].
Remedy:	<ul style="list-style-type: none">- increase the ramp-down time (p1121).- set the rounding times (p1130, p1136). This is particularly recommended in U/f operation to relieve the DC link voltage controller with rapid ramp-down times of the ramp-function generator.- Activate the DC link voltage controller (p1240, p1280).- adapt the dynamic response of the DC link voltage controller (p1243, p1247, p1283, p1287).- check the line supply and DC link voltage. set p0210 as low as possible (also see A07401, p1294 = 0).- check and correct the phase assignment at the power unit.- check the line supply phases. See also: p0210 (Drive unit line supply voltage), p1240 (Vdc controller configuration (vector control))
<hr/>	
F30003	Power unit: DC link voltage undervoltage
Message class:	Infeed faulted (13)
Reaction:	OFF2
Acknowledge:	IMMEDIATELY
Cause:	The power unit has detected an undervoltage condition in the DC link. <ul style="list-style-type: none">- line supply failure- line supply voltage below the permissible value.- line phase interrupted. Note: The monitoring threshold for the DC link undervoltage is the minimum of the following values: <ul style="list-style-type: none">- for a calculation, refer to p0210.
Remedy:	<ul style="list-style-type: none">- check the line supply voltage- check the line supply phases. See also: p0210 (Drive unit line supply voltage)
<hr/>	
F30004	Power unit: Overtemperature heat sink AC inverter
Message class:	Power electronics faulted (5)
Reaction:	OFF2
Acknowledge:	IMMEDIATELY
Cause:	The temperature of the power unit heat sink has exceeded the permissible limit value. <ul style="list-style-type: none">- insufficient cooling, fan failure.- overload.- ambient temperature too high.- pulse frequency too high. Fault value (r0949, interpret decimal): Temperature [1 bit = 0.01 °C].

- Remedy:**
- check whether the fan is running.
 - check the fan elements.
 - check whether the ambient temperature is in the permissible range.
 - check the motor load.
 - reduce the pulse frequency if this is higher than the rated pulse frequency.

Notice:

This fault can only be acknowledged after the alarm threshold for alarm A05000 has been undershot.

See also: p1800 (Pulse frequency setpoint)

F30005 Power unit: Overload I2t

Message class: Power electronics faulted (5)

Reaction: OFF2

Acknowledge: IMMEDIATELY

Cause: The power unit was overloaded (r0036 = 100 %).

- the permissible rated power unit current was exceeded for an inadmissibly long time.
- the permissible load duty cycle was not maintained.

Fault value (r0949, interpret decimal):

I2t [100 % = 16384].

- Remedy:**
- reduce the continuous load.
 - adapt the load duty cycle.
 - check the motor and power unit rated currents.
 - reduce the current limit (p0640).
 - during operation with U/f characteristic: reduce the integral time of the current limiting controller (p1341).
- See also: r0036 (Power unit overload I2t), r0206 (Rated power unit power), p0307 (Rated motor power)

F30011 Power unit: Line phase failure in main circuit

Message class: Network fault (2)

Reaction: OFF2 (OFF1)

Acknowledge: IMMEDIATELY

Cause: At the power unit, the DC link voltage ripple has exceeded the permissible limit value.

Possible causes:

- a line phase has failed.
- the 3 line phases are inadmissibly asymmetrical.
- the capacitance of the DC link capacitor forms a resonance frequency with the line inductance and the reactor integrated in the power unit.
- the fuse of a phase of a main circuit has ruptured.
- a motor phase has failed.

Fault value (r0949, interpret decimal):

Only for internal Siemens troubleshooting.

- Remedy:**
- check the main circuit fuses.
 - check whether a single-phase load is distorting the line voltages.
 - Detune the resonant frequency with the line inductance by using an upstream line reactor.
 - Dampen the resonant frequency with the line inductance by switching over the DC link voltage compensation in the software (see p1810) – or increase the smoothing (see p1806). However, this can have a negative impact on the torque ripple at the motor output.
 - check the motor feeder cables.

F30012 Power unit: Temperature sensor heat sink wire breakage

Message class: Power electronics faulted (5)

Reaction: OFF1 (OFF2)

Acknowledge: IMMEDIATELY

4 Faults and alarms

4.2 List of faults and alarms

Cause: The connection to a heat sink temperature sensor in the power unit is interrupted.
Fault value (r0949, interpret hexadecimal):
Bit 0: Module slot (electronics slot)
Bit 1: Air intake
Bit 2: Inverter 1
Bit 3: Inverter 2
Bit 4: Inverter 3
Bit 5: Inverter 4
Bit 6: Inverter 5
Bit 7: Inverter 6
Bit 8: Rectifier 1
Bit 9: Rectifier 2

Remedy: Contact the manufacturer.

F30013 Power unit: Temperature sensor heat sink short-circuit

Message class: Power electronics faulted (5)
Reaction: OFF1 (OFF2)
Acknowledge: IMMEDIATELY
Cause: The heat sink temperature sensor in the power unit is short-circuited.
Fault value (r0949, interpret hexadecimal):
Bit 0: Module slot (electronics slot)
Bit 1: Air intake
Bit 2: Inverter 1
Bit 3: Inverter 2
Bit 4: Inverter 3
Bit 5: Inverter 4
Bit 6: Inverter 5
Bit 7: Inverter 6
Bit 8: Rectifier 1
Bit 9: Rectifier 2

Remedy: Contact the manufacturer.

F30015 (N, A) Power unit: Phase failure motor cable

Message class: Application/technological function faulted (17)
Reaction: OFF2 (NONE, OFF1, OFF3)
Acknowledge: IMMEDIATELY
Cause: A phase failure in the motor feeder cable was detected.
The signal can also be output in the following cases:
- the motor is correctly connected, but the drive has stalled in U/f control. In this case, a current of 0 A is possibly measured in one phase due to asymmetry of the currents.
- the motor is correctly connected, however the closed-speed control is instable and therefore an oscillating torque is generated.
Note:
Chassis power units do not feature phase failure monitoring.

Remedy:
- check the motor feeder cables.
- increase the ramp-up or ramp-down time (p1120) if the drive has stalled in U/f control.
- check the speed controller settings.

A30016 (N) Power unit: Load supply switched off

Message class: Network fault (2)
Reaction: NONE
Acknowledge: NONE
Cause: The DC link voltage is too low.
Alarm value (r2124, interpret decimal):
DC link voltage at the time of trip [0.1 V].

Remedy: Under certain circumstances, the AC line supply is not switched on.

F30017	Power unit: Hardware current limit has responded too often
Message class:	Power electronics faulted (5)
Reaction:	OFF2
Acknowledge:	IMMEDIATELY
Cause:	<p>The hardware current limitation in the relevant phase (see A30031, A30032, A30033) has responded too often. The number of times the limit has been exceeded depends on the design and type of power unit.</p> <ul style="list-style-type: none">- closed-loop control is incorrectly parameterized.- fault in the motor or in the power cables.- the power cables exceed the maximum permissible length.- motor load too high- power unit defective. <p>Fault value (r0949, interpret binary): Bit 0: Phase U Bit 1: Phase V Bit 2: Phase W</p>
Remedy:	<ul style="list-style-type: none">- check the motor data.- check the motor circuit configuration (star-delta).- check the motor load.- check the power cable connections.- check the power cables for short-circuit or ground fault.- check the length of the power cables.- replace power unit.

F30021	Power unit: Ground fault
Message class:	Ground fault / inter-phase short-circuit detected (7)
Reaction:	OFF2
Acknowledge:	IMMEDIATELY
Cause:	<p>The power has detected a ground fault.</p> <p>Possible causes:</p> <ul style="list-style-type: none">- ground fault in the power cables.- ground fault at the motor.- CT defective.- when the brake closes, this causes the hardware DC current monitoring to respond.- short-circuit at the braking resistor. <p>Fault value (r0949, interpret decimal): 0: <ul style="list-style-type: none">- the hardware DC current monitoring has responded.- short-circuit at the braking resistor. > 0: Absolute value, summation current [32767 = 271 % rated current].</p>
Remedy:	<ul style="list-style-type: none">- check the power cable connections.- check the motor.- check the CT.- check the cables and contacts of the brake connection (a wire is possibly broken).- check the braking resistor. <p>See also: p0287 (Ground fault monitoring thresholds)</p>

F30022	Power unit: Monitoring U_{ce}
Message class:	Ground fault / inter-phase short-circuit detected (7)
Reaction:	OFF2
Acknowledge:	POWER ON

Cause:	In the power unit, the monitoring of the collector-emitter voltage (U_{ce}) of the semiconductor has responded. Possible causes: <ul style="list-style-type: none">- power supply of the IGBT gating module missing.- short-circuit at the power unit output.- defective semiconductor in the power unit. Fault value (r0949, interpret binary): Bit 0: Short-circuit in phase U Bit 1: Short circuit in phase V Bit 2: Short-circuit in phase W See also: r0949 (Fault value)
Remedy:	Check the power unit and replace if necessary.

F30024 Power unit: Overtemperature thermal model

Message class:	Power electronics faulted (5)
Reaction:	OFF2
Acknowledge:	IMMEDIATELY
Cause:	The temperature difference between the heat sink and chip has exceeded the permissible limit value. <ul style="list-style-type: none">- the permissible load duty cycle was not maintained.- insufficient cooling, fan failure.- overload.- ambient temperature too high.- pulse frequency too high. See also: r0037 (Power unit temperatures)
Remedy:	<ul style="list-style-type: none">- adapt the load duty cycle.- check whether the fan is running.- check the fan elements.- check whether the ambient temperature is in the permissible range.- check the motor load.- reduce the pulse frequency if this is higher than the rated pulse frequency.- if DC braking is active: reduce braking current (p1232).

F30025 Power unit: Chip overtemperature

Message class:	Power electronics faulted (5)
Reaction:	OFF2
Acknowledge:	IMMEDIATELY
Cause:	The chip temperature of the semiconductor has exceeded the permissible limit value. <ul style="list-style-type: none">- the permissible load duty cycle was not maintained.- insufficient cooling, fan failure.- overload.- ambient temperature too high.- pulse frequency too high. Fault value (r0949, interpret decimal): Temperature difference between the heat sink and chip [0.01 °C].
Remedy:	<ul style="list-style-type: none">- adapt the load duty cycle.- check whether the fan is running.- check the fan elements.- check whether the ambient temperature is in the permissible range.- check the motor load.- reduce the pulse frequency if this is higher than the rated pulse frequency. Notice: This fault can only be acknowledged after the alarm threshold for alarm A05001 has been undershot. See also: r0037 (Power unit temperatures)

F30027	Power unit: Precharging DC link time monitoring
Message class:	Infeed faulted (13)
Reaction:	OFF2
Acknowledge:	IMMEDIATELY
Cause:	<p>The power unit DC link was not able to be precharged within the expected time.</p> <ol style="list-style-type: none">1) There is no line supply voltage connected.2) The line contactor/line side switch has not been closed.3) The line supply voltage is too low.4) Line supply voltage incorrectly set (p0210).5) The precharging resistors are overheated as there were too many precharging operations per time unit.6) The precharging resistors are overheated as the DC link capacitance is too high.7) The DC link has either a ground fault or a short-circuit.8) Precharging circuit may be defective. <p>Fault value (r0949, interpret binary): yyyyxxxx hex: yyyy = power unit state</p> <ol style="list-style-type: none">0: Fault status (wait for OFF and fault acknowledgment).1: Restart inhibit (wait for OFF).2: Overvoltage condition detected -> change into the fault state.3: Undervoltage condition detected -> change into the fault state.4: Wait for bridging contactor to open -> change into the fault state.5: Wait for bridging contactor to open -> change into restart inhibit.6: Commissioning.7: Ready for precharging.8: Precharging started, DC link voltage less than the minimum switch-on voltage.9: Precharging, DC link voltage end of precharging still not detected.10: Wait for the end of the de-bounce time of the main contactor after precharging has been completed.11: Precharging completed, ready for pulse enable.12: Reserved. <p>xxxx = Missing internal enable signals, power unit (inverted bit-coded, FFFF hex -> all internal enable signals available)</p> <p>Bit 0: Power supply of the IGBT gating shut down. Bit 1: Ground fault detected. Bit 2: Peak current intervention. Bit 3: I2t exceeded. Bit 4: Thermal model overtemperature calculated. Bit 5: (heat sink, gating module, power unit) overtemperature measured. Bit 6: Reserved. Bit 7: Overvoltage detected. Bit 8: Power unit has completed precharging, ready for pulse enable. Bit 9: Reserved. Bit 10: Overcurrent detected. Bit 11: Reserved. Bit 12: Reserved. Bit 13: Vce fault detected, transistor de-saturated due to overcurrent/short-circuit. Bit 14: Undervoltage detected.</p> <p>See also: p0210 (Drive unit line supply voltage)</p>

4 Faults and alarms

4.2 List of faults and alarms

Remedy:

In general:

- check the line supply voltage at the input terminals.
- check the line supply voltage setting (p0210).
- wait until the precharging resistors have cooled down. For this purpose, preferably disconnect the infeed unit from the line supply.

For 5):

- carefully observe the permissible precharging frequency (refer to the appropriate Equipment Manual).

For 6):

- check the capacitance of the DC link and, if necessary, reduce it in accordance with the maximum permissible DC link capacitance (see relevant Equipment Manual).

For 7):

- check the DC link for a ground fault or short circuit.

See also: p0210 (Drive unit line supply voltage)

A30030 Power unit: Internal overtemperature alarm

Message class: Power electronics faulted (5)
Reaction: NONE
Acknowledge: NONE
Cause: The temperature inside the drive converter has exceeded the permissible temperature limit.

- insufficient cooling, fan failure.
- overload.
- ambient temperature too high.

Alarm value (r2124, interpret decimal):
Only for internal Siemens troubleshooting.

Remedy:

- possibly use an additional fan.
- check whether the ambient temperature is in the permissible range.

Notice:
This fault can only be acknowledged once the permissible temperature limit minus 5 K has been fallen below.

A30031 Power unit: Hardware current limiting in phase U

Message class: Power electronics faulted (5)
Reaction: NONE
Acknowledge: NONE
Cause: Hardware current limit for phase U responded. The pulsing in this phase is inhibited for one pulse period.

- closed-loop control is incorrectly parameterized.
- fault in the motor or in the power cables.
- the power cables exceed the maximum permissible length.
- motor load too high
- power unit defective.

Note:
Alarm A30031 is always output if, for a Power Module, the hardware current limiting of phase U, V or W responds.

Remedy:

- check the motor data and if required, recalculate the control parameters (p0340 = 3). As an alternative, run a motor data identification (p1910 = 1, p1960 = 1).
- check the motor circuit configuration (star/delta).
- check the motor load.
- check the power cable connections.
- check the power cables for short-circuit or ground fault.
- check the length of the power cables.

A30032 Power unit: Hardware current limiting in phase V

Message class: Power electronics faulted (5)
Reaction: NONE
Acknowledge: NONE

Cause:	Hardware current limit for phase V responded. The pulsing in this phase is inhibited for one pulse period. <ul style="list-style-type: none"> - closed-loop control is incorrectly parameterized. - fault in the motor or in the power cables. - the power cables exceed the maximum permissible length. - motor load too high - power unit defective.
Remedy:	Note: Alarm A30031 is always output if, for a Power Module, the hardware current limiting of phase U, V or W responds. Check the motor data and if required, recalculate the control parameters (p0340 = 3). As an alternative, run a motor data identification (p1910 = 1, p1960 = 1). <ul style="list-style-type: none"> - check the motor circuit configuration (star/delta). - check the motor load. - check the power cable connections. - check the power cables for short-circuit or ground fault. - check the length of the power cables.
<hr/>	
A30033	Power unit: Hardware current limiting in phase W
Message class:	Power electronics faulted (5)
Reaction:	NONE
Acknowledge:	NONE
Cause:	Hardware current limit for phase W responded. The pulsing in this phase is inhibited for one pulse period. <ul style="list-style-type: none"> - closed-loop control is incorrectly parameterized. - fault in the motor or in the power cables. - the power cables exceed the maximum permissible length. - motor load too high - power unit defective.
Remedy:	Note: Alarm A30031 is always output if, for a Power Module, the hardware current limiting of phase U, V or W responds. - check the motor data and if required, recalculate the control parameters (p0340 = 3). As an alternative, run a motor data identification (p1910 = 1, p1960 = 1). <ul style="list-style-type: none"> - check the motor circuit configuration (star/delta). - check the motor load. - check the power cable connections. - check the power cables for short-circuit or ground fault. - check the length of the power cables.
<hr/>	
A30034	Power unit: Internal overtemperature
Message class:	Power electronics faulted (5)
Reaction:	NONE
Acknowledge:	NONE
Cause:	The alarm threshold for internal overtemperature has been reached. If the temperature inside the unit continues to increase, fault F30036 may be triggered. <ul style="list-style-type: none"> - ambient temperature might be too high. - insufficient cooling, fan failure.
Remedy:	Alarm value (r2124, interpret decimal): Only for internal Siemens troubleshooting. <ul style="list-style-type: none"> - check the ambient temperature. - check the fan for the inside of the unit.
<hr/>	
F30035	Power unit: Air intake overtemperature
Message class:	Power electronics faulted (5)
Reaction:	OFF1 (OFF2)
Acknowledge:	IMMEDIATELY

4 Faults and alarms

4.2 List of faults and alarms

Cause: The air intake in the power unit has exceeded the permissible temperature limit.
For air-cooled power units, the temperature limit is at 55 °C.
- ambient temperature too high.
- insufficient cooling, fan failure.
Fault value (r0949, interpret decimal):
Temperature [0.01 °C].

Remedy:
- check whether the fan is running.
- check the fan elements.
- check whether the ambient temperature is in the permissible range.

Notice:
This fault can only be acknowledged after the alarm threshold for alarm A05002 has been undershot.

F30036 **Power unit: Internal overtemperature**

Message class: Power electronics faulted (5)
Reaction: OFF2
Acknowledge: IMMEDIATELY

Cause: The temperature inside the drive converter has exceeded the permissible temperature limit.
- insufficient cooling, fan failure.
- overload.
- ambient temperature too high.
Fault value (r0949, interpret decimal):
Only for internal Siemens troubleshooting.

Remedy:
- check whether the fan is running.
- check the fan elements.
- check whether the ambient temperature is in the permissible range.

Notice:
This fault can only be acknowledged once the permissible temperature limit minus 5 K has been fallen below.

F30037 **Power unit: Rectifier overtemperature**

Message class: Power electronics faulted (5)
Reaction: OFF2
Acknowledge: IMMEDIATELY

Cause: The temperature in the rectifier of the power unit has exceeded the permissible temperature limit.
- insufficient cooling, fan failure.
- overload.
- ambient temperature too high.
- line supply phase failure.
Fault value (r0949, interpret decimal):
Temperature [0.01 °C].

Remedy:
- check whether the fan is running.
- check the fan elements.
- check whether the ambient temperature is in the permissible range.
- check the motor load.
- check the line supply phases.

Notice:
This fault can only be acknowledged after the alarm threshold for alarm A05004 has been undershot.

A30042 **Power unit: Fan has reached the maximum operating hours**

Message class: Power electronics faulted (5)
Reaction: NONE
Acknowledge: NONE

Cause:	The maximum operating time of at least one fan will soon be reached, or has already been exceeded. Alarm value (r2124, interpret binary): Bit 0: heat sink fan will reach the maximum operating time in 500 hours. Bit 1: heat sink fan has exceeded the maximum operating time. Bit 8: internal device fan will reach the maximum operating time in 500 hours. Bit 9: internal device fan has exceeded the maximum operating time. Note: The maximum operating time of the heat sink fan in the power unit is displayed in p0252. The maximum operating time of the internal device fan in the power unit is internally specified and is fixed.
Remedy:	For the fan involved, carry out the following: - replace the fan. - reset the operating hours counter (p0251, p0254). See also: p0251 (Operating hours counter power unit fan)

A30048	Power unit: External fan faulty
Message class:	External measured value / signal state outside the permissible range (16)
Reaction:	NONE
Acknowledge:	NONE
Cause:	The feedback signal from the external fan indicates a fault. - fan faulty, blocked. - feedback signal inaccurate.
Remedy:	- check the external fan and replace if necessary. - if you are using an external fan with feedback signal, check its wiring (X12.2 or X13.2). Note: If you are using an external fan without feedback signal, check that the feedback terminal wiring at the power unit is connected to ground and make this connection if necessary (X12.1/2 or X13.1/2).

A30049	Power unit: Internal fan faulty
Message class:	Auxiliary unit faulted (20)
Reaction:	NONE
Acknowledge:	NONE
Cause:	The internal fan has failed.
Remedy:	Check the internal fan and replace if necessary.

F30051	Power unit: Motor holding brake short circuit detected
Message class:	External measured value / signal state outside the permissible range (16)
Reaction:	OFF2
Acknowledge:	IMMEDIATELY
Cause:	A short-circuit at the motor holding brake terminals has been detected. Fault value (r0949, interpret decimal): Only for internal Siemens troubleshooting.
Remedy:	- check the motor holding brake for a short-circuit. - check the connection and cable for the motor holding brake.

F30052	EEPROM data error
Message class:	Hardware/software error (1)
Reaction:	OFF2
Acknowledge:	POWER ON
Cause:	EEPROM data error of the power unit module. Fault value (r0949, interpret decimal): 0, 2, 3, 4: The EEPROM data read in from the power unit module is inconsistent. 1: EEPROM data is not compatible to the firmware of the Control Unit.
Remedy:	Replace power unit module.

A30054 (F, N)	Power unit: Undervoltage when opening the brake
Message class:	Supply voltage fault (undervoltage) (3)
Reaction:	NONE
Acknowledge:	NONE
Cause:	When the brake is being opened, it is detected that the power supply voltage is less than 21.4 V Alarm value (r2124, interpret decimal): Supply voltage fault [0.1 V]. Example: Alarm value = 195 --> voltage = 19.5 V
Remedy:	Check the 24 V voltage for stability and value.
F30055	Power unit: Braking chopper overcurrent
Message class:	Braking Module faulted (14)
Reaction:	OFF2
Acknowledge:	IMMEDIATELY
Cause:	An overcurrent condition has occurred in the braking chopper.
Remedy:	- check whether the braking resistor has a short circuit. - for an external braking resistor, check whether the resistor may have been dimensioned too small. Note: The braking chopper is only enabled again at pulse enable after the fault has been acknowledged.
A30057	Power unit: Line asymmetry
Message class:	Network fault (2)
Reaction:	NONE
Acknowledge:	NONE
Cause:	Frequencies have been detected on the DC link voltage that would suggest line asymmetry or failure of a line phase. It is also possible that a motor phase has failed. Fault F30011 is output if the alarm is present and at the latest after 5 minutes. The precise duration depends on the power unit type and the particular frequencies. For booksize and chassis power units, the duration also depends on how long the alarm has been active. Alarm value (r2124, interpret decimal): Only for internal Siemens troubleshooting.
Remedy:	- check the line phase connection. - check the motor feeder cable connections. If there is no phase failure of the line or motor, then line asymmetry is involved. - reduce the power in order to avoid fault F30011.
F30059	Power unit: Internal fan faulty
Message class:	Auxiliary unit faulted (20)
Reaction:	OFF2
Acknowledge:	IMMEDIATELY
Cause:	The internal power unit fan has failed and is possibly defective.
Remedy:	Check the internal fan and replace if necessary.
A30065 (F, N)	Voltage measured values not plausible
Message class:	Power electronics faulted (5)
Reaction:	NONE
Acknowledge:	NONE
Cause:	The voltage measurement is not supplying any plausible values Alarm value (r2124, interpret bitwise binary): Bit 1: Phase U. Bit 2: Phase V. Bit 3: Phase W.
Remedy:	- Deactivate voltage measurement (p0247.0 = 0). - Deactivate flying restart with voltage measurement (p0247.5 = 0) and deactivate fast flying restart (p1780.11 = 0).

F30068	Power unit: undertemperature inverter heat sink
Message class:	Power electronics faulted (5)
Reaction:	OFF2
Acknowledge:	IMMEDIATELY
Cause:	The actual inverter heat sink temperature is below the permissible minimum value. Possible causes: - the power unit is being operated at an ambient temperature that lies below the permissible range. - the temperature sensor evaluation is defective. Fault value (r0949, interpret decimal): inverter heat sink temperature [0.1 °C].
Remedy:	- ensure that higher ambient temperatures prevail. - replace the power unit.
<hr/>	
F30071	No new actual values received from the Power Module
Message class:	Internal (DRIVE-CLiQ) communication error (12)
Reaction:	OFF2
Acknowledge:	IMMEDIATELY
Cause:	More than one actual value telegram from the power unit module has failed.
Remedy:	Check the interface (adjustment and locking) to the power unit module.
<hr/>	
F30072	Setpoints can no longer be transferred to the Power Module
Message class:	Internal (DRIVE-CLiQ) communication error (12)
Reaction:	OFF2
Acknowledge:	IMMEDIATELY
Cause:	More than one setpoint telegram was not able to be transferred to the power unit module.
Remedy:	Check the interface (adjustment and locking) to the power unit module.
<hr/>	
F30074 (A)	Communication error between the Control Unit and Power Module
Message class:	Internal (DRIVE-CLiQ) communication error (12)
Reaction:	NONE
Acknowledge:	IMMEDIATELY
Cause:	Communications between the Control Unit (CU) and Power Module (PM) via the interface no longer possible. The CU may have been withdrawn or is incorrectly inserted. Fault value (r0949, interpret hexadecimal): 0 hex: - a Control Unit with external 24 V supply was withdrawn from the Power Module during operation. - with the Power Module switched off, the external 24 V supply for the Control Unit was interrupted for some time. 1 hex: The Control Unit was withdrawn from the Power Module during operation, although the encoderless safe motion monitoring functions are enabled. This is not supported. After re-inserting the Control Unit in operation, communications to the Power Module no longer possible. 20A hex: The Control Unit was inserted on a Power Module, which has another code number. 20B hex: The Control Unit was inserted on a Power Module, which although it has the same code number, has a different serial number. The Control Unit executes an automatic warm restart to accept the new calibration data.
Remedy:	For fault value = 0 and 20A hex: Insert the Control Unit on an appropriate Power Module and continue operation. If required, carry out a POWER ON of the Control Unit. For fault value = 1 hex: Carry out a POWER ON of the Control Unit.
<hr/>	
F30075	Configuration of the power unit unsuccessful
Message class:	Internal (DRIVE-CLiQ) communication error (12)
Reaction:	OFF2
Acknowledge:	IMMEDIATELY

Cause:	A communication error has occurred while configuring the power unit using the Control Unit. The cause is not clear. Fault value (r0949, interpret decimal): 0: The output filter initialization was unsuccessful. 1: Activation/deactivation of the regenerative feedback functionality was unsuccessful.
Remedy:	- acknowledge the fault and continue operation. - if the fault reoccurs, carry out a POWER ON (switch-off/switch-on). - if required, replace the power unit.

F30080 Power unit: Current increasing too quickly

Message class:	Power electronics faulted (5)
Reaction:	OFF2
Acknowledge:	IMMEDIATELY
Cause:	The power unit has detected an excessive rate of rise in the overvoltage range. - closed-loop control is incorrectly parameterized. - motor has a short-circuit or fault to ground (frame). - U/f operation: Up ramp set too low. - U/f operation: rated current of motor much greater than that of power unit. - power cables are not correctly connected. - power cables exceed the maximum permissible length. - power unit defective. Fault value (r0949, interpret bitwise binary): Bit 0: Phase U. Bit 1: Phase V. Bit 2: Phase W.
Remedy:	- check the motor data - if required, carry out commissioning. - check the motor circuit configuration (star-delta) - U/f operation: Increase up ramp. - U/f operation: Check assignment of rated currents of motor and power unit. - check the power cable connections. - check the power cables for short-circuit or ground fault. - check the length of the power cables. - replace power unit.

F30081 Power unit: Switching operations too frequent

Message class:	Power electronics faulted (5)
Reaction:	OFF2
Acknowledge:	IMMEDIATELY
Cause:	The power unit has executed too many switching operations for current limitation. - closed-loop control is incorrectly parameterized. - motor has a short-circuit or fault to ground (frame). - U/f operation: Up ramp set too low. - U/f operation: rated current of motor much greater than that of power unit. - power cables are not correctly connected. - power cables exceed the maximum permissible length. - power unit defective. Fault value (r0949, interpret bitwise binary): Bit 0: Phase U. Bit 1: Phase V. Bit 2: Phase W.

- Remedy:**
- check the motor data - if required, carry out commissioning.
 - check the motor circuit configuration (star-delta)
 - *U/f* operation: Increase up ramp.
 - *U/f* operation: Check assignment of rated currents of motor and power unit.
 - check the power cable connections.
 - check the power cables for short-circuit or ground fault.
 - check the length of the power cables.
 - replace power unit.

F30105 **PU: Actual value sensing fault**

Message class: Power electronics faulted (5)

Reaction: OFF2

Acknowledge: IMMEDIATELY

Cause: At least one incorrect actual value channel was detected on the Power Stack Adapter (PSA).
The incorrect actual value channels are displayed in the following diagnostic parameters.

Remedy: Evaluate the diagnostic parameters.
If the actual value channel is incorrect, check the components and if required, replace.

A30502 **Power unit: DC link overvoltage**

Message class: DC link overvoltage (4)

Reaction: NONE

Acknowledge: NONE

Cause: The power unit has detected overvoltage in the DC link on a pulse inhibit.

- device connection voltage too high.
- line reactor incorrectly dimensioned.

Alarm value (r0949, interpret decimal):
DC link voltage [1 bit = 100 mV].
See also: r0070 (Actual DC link voltage)

Remedy:

- check the device supply voltage (p0210).
- check the dimensioning of the line reactor.

See also: p0210 (Drive unit line supply voltage)

F30600 **SI P2: STOP A initiated**

Message class: Safety monitoring channel has identified an error (10)

Reaction: OFF2

Acknowledge: IMMEDIATELY (POWER ON)

Cause: The drive-integrated "Safety Integrated" function on processor 2 has detected an error and initiated a STOP A.

- forced checking procedure (test stop) of the safety switch-off signal path on processor 2 unsuccessful.
- subsequent response to fault F30611 (defect in a monitoring channel).

Fault value (r0949, interpret decimal):
0: Stop request from processor 1.
1005: Pulses suppressed although STO not selected and there is no internal STOP A present.
1010: Pulses enabled although STO is selected or an internal STOP A is present.
1011: Internal fault for the pulse enable in the Power Module.
9999: Subsequent response to fault F30611.

Remedy:

- select Safe Torque Off and de-select again.
- carry out a POWER ON (switch-off/switch-on) for all components.
- replace Power Module involved.

For fault value = 9999:
- carry out diagnostics for fault F30611.

Note:
PM: Power Module
STO: Safe Torque Off

F30611 (A)	SI P2: Defect in a monitoring channel
Message class:	Safety monitoring channel has identified an error (10)
Reaction:	NONE (OFF1, OFF2, OFF3)
Acknowledge:	IMMEDIATELY (POWER ON)
Cause:	<p>The drive-integrated "Safety Integrated" function on processor 2 has detected a fault in the data cross-check between the two monitoring channels and has initiated a STOP F.</p> <p>As a consequence of this fault, fault F30600 (SI P2: STOP A initiated) is output.</p> <p>Fault value (r0949, interpret decimal):</p> <p>0: Stop request from the other monitoring channel.</p> <p>1 ... 999:</p> <p>Number of the cross-compared data that resulted in this fault. This number is also displayed in r9795.</p> <p>2: SI enable safety functions (p9601, p9801). Crosswise data comparison is only carried out for the supported bits.</p> <p>3: SI F-DI changeover discrepancy time (p9650, p9850).</p> <p>8: SI PROFIsafe address (p9610, p9810).</p> <p>9: SI debounce time for STO (p9651, p9851).</p> <p>1000: Watchdog timer has expired.</p> <p>Within the time of approx. 5 x p9650, alternatively, the following was defined:</p> <ul style="list-style-type: none">- the signal at F-DI continually changed with time intervals less than or equal to the discrepancy time (p9650/p9850).- via PROFIsafe, STO (also as subsequent response) was continually selected and deselected with time intervals less than or equal to the discrepancy time (p9650/p9850). <p>1001, 1002: Initialization error, change timer / check timer.</p> <p>2000: Status of the STO selection for both monitoring channels are different.</p> <p>2001: Feedback signal of the safe pulse cancellation for both monitoring channels different.</p> <p>2003: Status of the STO terminal for processor 1 and processor 2 different.</p> <p>6000 ... 6999:</p> <p>Error in the PROFIsafe control.</p> <p>For these fault values, the failsafe control signals (failsafe values) are transferred to the safety functions.</p> <p>The significance of the individual message values is described in safety fault F01611.</p>
Remedy:	<p>For fault values 1 ... 999 described in "Cause":</p> <ul style="list-style-type: none">- check the cross data comparison that resulted in a STOP F.- carry out a POWER ON (switch-off/switch-on). <p>For fault value = 1000:</p> <ul style="list-style-type: none">- check the wiring of the F-DI (contact problems).- PROFIsafe: Remove contact problems/faults at the PROFIBUS master/PROFINET controller.- check the discrepancy time, and if required, increase the value (p9650/p9850). <p>For fault value = 1001, 1002:</p> <ul style="list-style-type: none">- carry out a POWER ON (switch-off/switch-on). <p>For fault value = 2000, 2001, 2003:</p> <ul style="list-style-type: none">- check the discrepancy time, and if required, increase the value (p9650/p9850).- check the wiring of the F-DI (contact problems).- check the causes of the STO selection in r9772. <p>For fault value = 6000 ... 6999:</p> <p>Refer to the description of the message values in safety fault F01611.</p> <p>For fault values that are described in "Cause":</p> <ul style="list-style-type: none">- carry out a POWER ON (switch-off/switch-on).- contact Technical Support.- replace Control Unit. <p>Note:</p> <p>F-DI: Failsafe Digital Input</p> <p>STO: Safe Torque Off</p>

N30620 (F, A)	SI P2: Safe Torque Off active
Message class:	Safety monitoring channel has identified an error (10)
Reaction:	NONE
Acknowledge:	NONE

Cause:	The "Safe Torque Off" (STO) function has been selected on processor 2 using the input terminal and is active.
	Note: This message does not result in a safety stop response.
Remedy:	Not necessary.
	Note: STO: Safe Torque Off

F30625	SI P2: Sign-of-life error in safety data
Message class:	Hardware/software error (1)
Reaction:	OFF2
Acknowledge:	IMMEDIATELY (POWER ON)
Cause:	The drive-integrated "Safety Integrated" function on processor 2 has detected an error in the sign-of-life of the safety data and initiated a STOP A. - there is a communication error between processor 1 and processor 2 or communication has failed. - a time slice overflow of the safety software has occurred. Fault value (r0949, interpret decimal): Only for internal Siemens troubleshooting.
Remedy:	- select Safe Torque Off and de-select again. - carry out a POWER ON (switch-off/switch-on). - check whether additional faults are present and if required, perform diagnostics. - check the electrical cabinet design and cable routing for EMC compliance

F30649	SI P2: Internal software error
Message class:	Hardware/software error (1)
Reaction:	OFF2
Acknowledge:	IMMEDIATELY (POWER ON)
Cause:	An internal error in the Safety Integrated software on processor 2 has occurred. Note: This fault results in a STOP A that cannot be acknowledged. Fault value (r0949, interpret hexadecimal): Only for internal Siemens troubleshooting.
Remedy:	- carry out a POWER ON (switch-off/switch-on). - re-commission the "Safety Integrated" function and carry out a POWER ON. - contact Technical Support. - replace Control Unit.

F30650	SI P2: Acceptance test required
Message class:	Error in the parameterization / configuration / commissioning procedure (18)
Reaction:	OFF2
Acknowledge:	IMMEDIATELY (POWER ON)
Cause:	The drive-integrated "Safety Integrated" function on processor 2 requires an acceptance test. Note: This fault results in a STOP A that can be acknowledged. Fault value (r0949, interpret decimal): 130: Safety parameters for processor 2 not available. Note: This fault value is always output when Safety Integrated is commissioned for the first time. 1000: Reference and actual checksum on processor 2 are not identical (booting). - at least one checksum-checked piece of data is defective. - safety parameters set offline and loaded into the Control Unit. 2000: Reference and actual checksum on processor 2 are not identical (commissioning mode). - reference checksum incorrectly entered on processor 2 (p9899 not equal to r9898). 2003: Acceptance test is required as a safety parameter has been changed. 2010: Enable of safety-related brake control between the two monitoring channels differ (p9602 not equal to p9802). 9999: Subsequent response of another safety-related fault that occurred when booting that requires an acceptance test.

Remedy:

- For fault value = 130:
 - carry out safety commissioning routine.
- For fault value = 1000:
 - again carry out safety commissioning routine.
 - replace the memory card or Control Unit.
 - Using STARTER, activate the safety parameters for the drive involved (change settings, copy parameters, activate settings).
- For fault value = 2000:
 - check the safety parameters on processor 2 and adapt the reference checksum (p9899).
- For fault value = 2003:
 - carry out an acceptance test and generate an acceptance report.
- For fault value = 2010:
 - check the enable the safety-related brake control on both monitoring channels (p9602 = p9802).
- For fault value = 9999:
 - carry out diagnostics for the other safety-related fault that is present.

See also: p9799 (SI reference checksum SI parameters (processor 1)), p9899 (SI reference checksum SI parameters (processor 2))

F30651 SI P2: Synchronization with Control Unit unsuccessful

Message class: Hardware/software error (1)
Reaction: OFF2
Acknowledge: IMMEDIATELY (POWER ON)
Cause: The drive-integrated "Safety Integrated" function requires synchronization of the safety time slices on processor 1 and processor 2. This synchronization routine was unsuccessful.
Note:
This fault results in a STOP A that cannot be acknowledged.
Fault value (r0949, interpret decimal):
Only for internal Siemens troubleshooting.
Remedy: Carry out a POWER ON (switch-off/switch-on).

F30655 SI P2: Align monitoring functions

Message class: Error in the parameterization / configuration / commissioning procedure (18)
Reaction: OFF2
Acknowledge: IMMEDIATELY (POWER ON)
Cause: An error has occurred when aligning the Safety Integrated monitoring functions on processor 1 and processor 2. No common set of supported SI monitoring functions was able to be determined.

- there is a communication error between processor 1 and processor 2 or communication has failed.

Note:
This fault results in a STOP A that cannot be acknowledged.
Fault value (r0949, interpret hexadecimal):
Only for internal Siemens troubleshooting.
Remedy:

- carry out a POWER ON (switch-off/switch-on).
- check the electrical cabinet design and cable routing for EMC compliance

F30656 SI P2: Parameter processor 2 parameter error

Message class: Hardware/software error (1)
Reaction: OFF2
Acknowledge: IMMEDIATELY (POWER ON)
Cause: When accessing the Safety Integrated parameters for the processor 2 in the non-volatile memory, an error has occurred.
Note:
This fault results in a STOP A that can be acknowledged.
Fault value (r0949, interpret decimal):
129: Safety parameters for processor 2 corrupted.
131: Internal software error on processor 1.
255: Internal software error on processor 2.

- Remedy:**
- re-commission the safety functions.
 - replace the memory card or Control Unit.
- For fault value = 129:
- activate the safety commissioning mode (p0010 = 95).
 - start the copy function for SI parameters (p9700 = D0 hex).
 - acknowledge data change (p9701 = DC hex).
 - exit the safety commissioning mode (p0010 = 0).
 - save all parameters (p0971 = 1 or "copy RAM to ROM").
 - carry out a POWER ON (switch-off/switch-on) for the Control Unit.

F30659 **SI P2: Write request for parameter rejected**

- Message class:** Error in the parameterization / configuration / commissioning procedure (18)
Reaction: OFF2
Acknowledge: IMMEDIATELY (POWER ON)
Cause: The write request for one or several Safety Integrated parameters on processor 2 was rejected.
Note:
This fault does not result in a safety stop response.
Fault value (r0949, interpret decimal):
10: An attempt was made to enable the STO function although this cannot be supported.
15: An attempt was made to enable the motion monitoring functions integrated in the drive although these cannot be supported.
16: An attempt was made to enable the PROFIsafe communications although this cannot be supported.
18: An attempt was made to enable the PROFIsafe function for Basic Functions although this cannot be supported.
20: An attempt was made to simultaneously enable both the drive-integrated motion monitoring functions via integrated F-DI and STO via terminals, even though these cannot be supported at the same time.
28: An attempt was made to enable the "STO via terminals at the Power Module" function although this cannot be supported.
See also: r9771 (SI common functions (processor 1)), r9871 (SI common functions (processor 2))
- Remedy:**
- For fault value = 10, 15, 16, 18:
- check whether there are faults in the safety function alignment (F01655, F30655) and if required, carry out diagnostics for the faults involved.
 - use a Control Unit that supports the required function.
- For fault value = 28:
- use the power unit with the feature "STO via terminals at the Power Module".
- Note:**
F-DI: Failsafe Digital Input
STO: Safe Torque Off

F30662 **Error in internal communications**

- Message class:** Hardware/software error (1)
Reaction: OFF2
Acknowledge: POWER ON
Cause: A module-internal communication error has occurred.
Fault value (r0949, interpret hexadecimal):
Only for internal Siemens troubleshooting.
- Remedy:**
- carry out a POWER ON (switch-off/switch-on).
 - upgrade firmware to later version.
 - contact Technical Support.

F30664 **Error while booting**

- Message class:** Hardware/software error (1)
Reaction: OFF2
Acknowledge: POWER ON
Cause: An error has occurred during booting.
Fault value (r0949, interpret hexadecimal):
Only for internal Siemens troubleshooting.

4.2 List of faults and alarms

Remedy:

- carry out a POWER ON (switch-off/switch-on).
- upgrade firmware to later version.
- contact Technical Support.

F30665 **SI P2: System is defective**

Message class: Hardware/software error (1)

Reaction: OFF2

Acknowledge: IMMEDIATELY

Cause: A system defect was detected before the last boot or in the actual one. The system might have been rebooted (reset).

Fault value (r0949, interpret hexadecimal):
200000 hex, 400000 hex:

- fault in the actual booting/operation.

Additional values:

- defect before the last time that the system booted.

Remedy:

- carry out a POWER ON (switch-off/switch-on).
- upgrade firmware to later version.
- contact Technical Support.

For fault value = 400000 hex:

- ensure that the Control Unit is connected to the Power Module.

F30682 **SI Motion P2: Monitoring function not supported**

Message class: Error in the parameterization / configuration / commissioning procedure (18)

Reaction: OFF2

Acknowledge: IMMEDIATELY (POWER ON)

Cause: The monitoring function enabled in p9301, p9501, p9601 or p9801 is not supported in this firmware version.

Note:

This message does not result in a safety stop response.

Fault value (r0949, interpret decimal):

- 1: Monitoring function SLP not supported (p9301.1).
- 2: Monitoring function SCA not supported (p9301.7 and p9301.8 ... 15).
- 3: Monitoring function SLS override not supported (p9301.5).
- 4: Monitoring function external ESR activation not supported (p9301.4).
- 5: Monitoring function F-DI in PROFIsafe not supported (p9301.30).
- 6: Enable actual value synchronization not supported (p9301.3).
- 9: Monitoring function not supported by the firmware or enable bit not used.
- 24: Monitoring function SDI not supported.

Remedy: De-select the monitoring function involved.

Note:

ESR: Extended Stop and Retract
F-DI: Failsafe Digital Input
SCA: Safe Cam
SLP: Safely-Limited Position
SLS: Safely-Limited Speed
SDI: Safe Direction (safe motion direction)

See also: p9601 (SI enable functions integrated in the drive (processor 1)), p9801 (SI enable functions integrated in the drive (processor 2)), r9871 (SI common functions (processor 2))

A30693 (F) **SI P2: Safety parameter settings changed, POWER ON required**

Message class: Error in the parameterization / configuration / commissioning procedure (18)

Reaction: NONE

Acknowledge: NONE

Cause: Safety parameters have been changed; these will only take effect following a POWER ON.
Notice:
All changed parameters of the safety motion monitoring functions will only take effect following a POWER ON.
Alarm value (r2124, interpret decimal):
Parameter number of the safety parameter which has changed, necessitating a POWER ON.

Remedy: - execute the function "Copy RAM to ROM".
- carry out a POWER ON (switch-off/switch-on).

A30788 Automatic test stop: wait for STO deselection via SMM

Message class: Safety monitoring channel has identified an error (10)
Reaction: NONE
Acknowledge: NONE
Cause: The automatic test stop was not able to be carried out after powering up.
Possible causes:
- the STO function is selected via Safety Extended Functions.
- a safety message is present, that resulted in a STO.

Remedy: - Deselect STO via Safety Extended Functions.
- remove the cause of the safety messages and acknowledge the messages.
The automatic test stop is performed after removing the cause.

N30800 (F) Power unit: Group signal

Message class: Power electronics faulted (5)
Reaction: OFF2
Acknowledge: NONE
Cause: The power unit has detected at least one fault.
Remedy: Evaluate the other messages that are presently available.

F30802 Power unit: Time slice overflow

Message class: Hardware/software error (1)
Reaction: OFF2
Acknowledge: IMMEDIATELY
Cause: A time slice overflow has occurred.
Fault value (r0949, interpret decimal):
xx: Time slice number xx

Remedy: - carry out a POWER ON (switch-off/switch-on) for all components.
- upgrade firmware to later version.
- contact Technical Support.

F30804 (N, A) Power unit: CRC

Message class: Hardware/software error (1)
Reaction: OFF2 (OFF1, OFF3)
Acknowledge: IMMEDIATELY
Cause: A checksum error (CRC error) has occurred for the power unit.

Remedy: - carry out a POWER ON (switch-off/switch-on) for all components.
- upgrade firmware to later version.
- contact Technical Support.

F30805 Power unit: EEPROM checksum error

Message class: Hardware/software error (1)
Reaction: OFF2
Acknowledge: IMMEDIATELY
Cause: Internal parameter data is corrupted.
Fault value (r0949, interpret hexadecimal):
01: EEPROM access error.
02: Too many blocks in the EEPROM.

Remedy: Replace the module.

F30809 Power unit: Switching information not valid

Message class: Hardware/software error (1)

Reaction: OFF2

Acknowledge: IMMEDIATELY

Cause: For 3P gating unit, the following applies:
The last switching status word in the setpoint telegram is identified by the end ID. Such an end ID was not found.

Remedy:

- carry out a POWER ON (switch-off/switch-on) for all components.
- upgrade firmware to later version.
- contact Technical Support.

A30810 (F) Power unit: Watchdog timer

Message class: Hardware/software error (1)

Reaction: NONE

Acknowledge: NONE

Cause: When booting it was detected that the cause of the previous reset was an SAC watchdog timer overflow.

Remedy:

- carry out a POWER ON (switch-off/switch-on) for all components.
- upgrade firmware to later version.
- contact Technical Support.

F30850 Power unit: Internal software error

Message class: Hardware/software error (1)

Reaction: OFF1 (NONE, OFF2, OFF3)

Acknowledge: POWER ON

Cause: An internal software error has occurred in the power unit.
Fault value (r0949, interpret decimal):
Only for internal Siemens troubleshooting.

Remedy:

- replace power unit.
- if required, upgrade the firmware in the power unit.
- contact Technical Support.

F30903 Power unit: I2C bus error occurred

Message class: Hardware/software error (1)

Reaction: OFF2 (IASC/DCBRK, NONE, OFF1, OFF3, STOP2)

Acknowledge: IMMEDIATELY

Cause: Communications error with an EEPROM or an analog/digital converter.
Fault value (r0949, interpret hexadecimal):
80000000 hex:
- internal software error.
00000001 hex ... 0000FFFF hex:
- module fault.

Remedy:

For fault value = 80000000 hex:
- upgrade firmware to later version.

For fault value = 00000001 hex ... 0000FFFF hex:
- replace the module.

A30920 (F) Temperature sensor fault

Message class: Power electronics faulted (5)

Reaction: NONE

Acknowledge: NONE

Cause: When evaluating the temperature sensor, an error occurred.
Alarm value (r2124, interpret decimal):
1: Wire breakage or sensor not connected.
KTY: R > 2120 Ohm, PT1000: R > 2120 Ohm
2: Measured resistance too low.
PTC: R < 20 Ohm, KTY: R < 50 Ohm, PT1000: R < 603 Ohm

Remedy:

- make sure that the sensor is connected correctly.
- replace the sensor.

F30950 Power unit: Internal software error

Message class: Hardware/software error (1)
Reaction: OFF2
Acknowledge: POWER ON
Cause: An internal software error has occurred.
Fault value (r0949, interpret decimal):
Information about the fault source.
Only for internal Siemens troubleshooting.

Remedy:

- if necessary, upgrade the firmware in the power unit to a later version.
- contact Technical Support.

A30999 (F, N) Power unit: Unknown alarm

Message class: Power electronics faulted (5)
Reaction: NONE
Acknowledge: NONE
Cause: An alarm occurred on the power unit that cannot be interpreted by the Control Unit firmware.
This can occur if the firmware on this component is more recent than the firmware on the Control Unit.
Alarm value (r2124, interpret decimal):
Alarm number.
Note:
If required, the significance of this new alarm can be read about in a more recent description of the Control Unit.

Remedy:

- replace the firmware on the power unit by an older firmware version (r0128).
- upgrade the firmware on the Control Unit (r0018).

F35950 TM: Internal software error

Message class: Hardware/software error (1)
Reaction: OFF2 (NONE)
Acknowledge: POWER ON
Cause: An internal software error has occurred.
Fault value (r0949, interpret decimal):
Information about the fault source.
Only for internal Siemens troubleshooting.

Remedy:

- if necessary, upgrade the firmware in the Terminal Module to a later version.
- contact Technical Support.

A50001 (F) PROFINET configuration error

Message class: Communication error to the higher-level control system (9)
Reaction: NONE
Acknowledge: NONE
Cause: A PROFINET controller attempts to establish a connection using an incorrect configuring telegram. The "Shared Device" function has been activated (p8929 = 2).
Alarm value (r2124, interpret decimal):
10: A/F-CPU configures mixed PZD/PROFIsafe telegram.
13: F-CPU and PROFIsafe is not activated (p9601.3).
15: PROFIsafe telegram of the F-CPU does not match the setting in p9501.30.
See also: p9601 (SI enable functions integrated in the drive (processor 1))

Remedy: Check the configuration of the PROFINET controllers as well as the p8929 setting.

A50010 (F) PROFINET: Consistency error affecting adjustable parameters

Message class: Communication error to the higher-level control system (9)
Reaction: NONE
Acknowledge: NONE

4 Faults and alarms

4.2 List of faults and alarms

Cause: A consistency error was detected when activating the configuration (p8925) for the PROFINET interface. The currently set configuration has not been activated.
Alarm value (r2124, interpret decimal):
0: general consistency error
1: error in the IP configuration (IP address, subnet mask or standard gateway).
2: Error in the station names.
3: DHCP was not able to be activated, as a cyclic PROFINET connection already exists.
4: a cyclic PROFINET connection is not possible as DHCP is activated.
Note:
DHCP: Dynamic Host Configuration Protocol
See also: p8920 (PN Name of Station), p8921 (PN IP address), p8922 (PN Default Gateway), p8923 (PN Subnet Mask), p8924 (PN DHCP Mode)

Remedy: - check the required interface configuration (p8920 and following), correct if necessary, and activate (p8925).
or
- reconfigure the station via the "Edit Ethernet node" screen form (e.g. with STARTER commissioning software).
See also: p8925 (Activate PN interface configuration)

A50011 (F) Ethernet/IP: configuration error
Message class: Communication error to the higher-level control system (9)
Reaction: NONE
Acknowledge: NONE
Cause: An EtherNet/IP controller attempts to establish a connection using an incorrect configuring telegram. The telegram length set in the controller does not match the parameterization in the drive device.
Remedy: Check the set telegram length.
For p0922 not equal to 999, then the length of the selected telegram applies.
For p0922 = 999, the maximum interconnected PZD (r2067) applies.
See also: p0922 (PROFIdrive PZD telegram selection), r2067 (PZD maximum interconnected)

A50020 (F) PROFINET: Second controller missing
Message class: Communication error to the higher-level control system (9)
Reaction: NONE
Acknowledge: NONE
Cause: The PROFINET function "Shared Device" has been activated (p8929 = 2). However, only the connection to a PROFINET controller is present.
Remedy: Check the configuration of the PROFINET controllers as well as the p8929 setting.

F50510 FBLOCKS: Logon of the runtime group rejected
Message class: General drive fault (19)
Reaction: OFF2
Acknowledge: IMMEDIATELY
Cause: When the runtime groups of the free function blocks attempted to log on with the sampling time management, the logon of at least one runtime group was rejected.
Too many different hardware sampling times may have been assigned to the free function blocks.
Remedy: - check number of available hardware sampling times ($T_{\text{sample}} < 8 \text{ ms}$) (r7903).

F50511 FBLOCKS: Memory no longer available for free function blocks
Message class: General drive fault (19)
Reaction: OFF2
Acknowledge: IMMEDIATELY
Cause: When the free function blocks were activated, more memory was requested than was available on the Control Unit.
Remedy: Not necessary.

A50513 (F) FBLOCKS: Run sequence value already assigned
Message class: General drive fault (19)
Reaction: NONE
Acknowledge: NONE

Cause: An attempt was made to assign a run sequence value already assigned to a function block on this drive object to another additional function block on the same drive object. A run sequence value can only be precisely assigned to one function block on one drive object.

Remedy: Set another value that is still available on this drive object for the run sequence.

A50517 FBLOCKS: Int. meas. active

Message class: General drive fault (19)
Reaction: NONE
Acknowledge: NONE
Cause: A Siemens internal measurement has been activated.
Remedy: Carry out a POWER ON (switch-off/switch-on) for the Control Unit involved.

F50518 FBLOCKS: Sampling time of free runtime group differs at download

Message class: General drive fault (19)
Reaction: NONE
Acknowledge: IMMEDIATELY
Cause: In the STARTER/SCOUT project that was downloaded, the hardware sampling time of a free runtime group ($1 \leq p20000[i] \leq 256$) was set to a value that was either too low or too high.
The sampling time must be between 1 ms and the value r20003 - r20002.
If the sampling time of the selected free runtime group is < 1 ms, the equivalent value of 1 ms is used.
If the value $\geq r20003$, then the sampling time is set to the next higher or the same software sampling time $\geq r21003$.

Fault value (r0949, interpret decimal):

Number of the p20000 index of the runtime group where the sampling time is incorrectly set.

Number of the runtime group = fault value + 1

Remedy:

- Correctly set the sampling time of the runtime group.
- If required, take all of the blocks from the runtime group.

Note:

Fault F50518 only detects an incorrectly parameterized runtime group. If, after correcting p20000[i] in the project, this error occurs again at download, then the runtime group involved should be identified using the fault value (r0949) and the sampling time correctly set.

Appendix

A

Content

A.1	ASCII table (characters that can be displayed)	792
A.2	List of abbreviations	795

A.1 ASCII table (characters that can be displayed)

The following table includes the decimal and hexadecimal notation of ASCII characters that can be displayed (printable).

Table A-1 ASCII table (characters that can be displayed)

Character	Decimal	Hexadecimal	Meaning
	32	20	Space
!	33	21	Exclamation mark
"	34	22	Quotation mark
#	35	23	Number sign
\$	36	24	Dollar
%	37	25	Percent
&	38	26	Ampersand
'	39	27	Apostrophe, closing single quotation mark
(40	28	Opening parenthesis
)	41	29	Closing parenthesis
*	42	2A	Asterisk
+	43	2B	Plus
,	44	2C	Comma
-	45	2D	Hyphen, minus
.	46	2E	Period, decimal point
/	47	2F	Slash, slant
0	48	30	Digit 0
1	49	31	Digit 1
2	50	32	Digit 2
3	51	33	Digit 3
4	52	34	Digit 4
5	53	35	Digit 5
6	54	36	Digit 6
7	55	37	Digit 7
8	56	38	Digit 8
9	57	39	Digit 9
:	58	3A	Colon
;	59	3B	Semicolon
<	60	3C	Less than
=	61	3D	Equals
>	62	3E	Greater than
?	63	3F	Question mark
@	64	40	Commercial At

Table A-1 ASCII table (characters that can be displayed), continued

Character	Decimal	Hexadecimal	Meaning
A	65	41	Capital letter A
B	66	42	Capital letter B
C	67	43	Capital letter C
D	68	44	Capital letter D
E	69	45	Capital letter E
F	70	46	Capital letter F
G	71	47	Capital letter G
H	72	48	Capital letter H
I	73	49	Capital letter I
J	74	4A	Capital letter J
K	75	4B	Capital letter K
L	76	4C	Capital letter L
M	77	4D	Capital letter M
N	78	4E	Capital letter N
O	79	4F	Capital letter O
P	80	50	Capital letter P
Q	81	51	Capital letter Q
R	82	52	Capital letter R
S	83	53	Capital letter S
T	84	54	Capital letter T
U	85	55	Capital letter U
V	86	56	Capital letter V
W	87	57	Capital letter W
X	88	58	Capital letter X
Y	89	59	Capital letter Y
Z	90	5A	Capital letter Z
[91	5B	Opening bracket
\	92	5C	Backslash
]	93	5D	Closing bracket
^	94	5E	Circumflex
_	95	5F	Underline
'	96	60	Opening single quotation mark
a	97	61	Small letter a
b	98	62	Small letter b
c	99	63	Small letter c
d	100	64	Small letter d

A.1 ASCII table (characters that can be displayed)

Table A-1 ASCII table (characters that can be displayed), continued

Character	Decimal	Hexadecimal	Meaning
e	101	65	Small letter e
f	102	66	Small letter f
g	103	67	Small letter g
h	104	68	Small letter h
i	105	69	Small letter i
j	106	6A	Small letter j
k	107	6B	Small letter k
l	108	6C	Small letter l
m	109	6D	Small letter m
n	110	6E	Small letter n
o	111	6F	Small letter o
p	112	70	Small letter p
q	113	71	Small letter q
r	114	72	Small letter r
s	115	73	Small letter s
t	116	74	Small letter t
u	117	75	Small letter u
v	118	76	Small letter v
w	119	77	Small letter w
x	120	78	Small letter x
y	121	79	Small letter y
z	122	7A	Small letter z
{	123	7B	Opening brace
	124	7C	Vertical line
}	125	7D	Closing brace
~	126	7E	Tilde

A.2 List of abbreviations

Note

The following list of abbreviations includes all abbreviations and their meanings used in the entire SINAMICS family of drives.

Abbreviation	Derivation of abbreviation	Significance
A		
A...	Alarm	Warning
AC	Alternating Current	Alternating current
ADC	Analog Digital Converter	Analog digital converter
AI	Analog Input	Analog input
AIM	Active Interface Module	Active Interface Module
ALM	Active Line Module	Active Line Module
AO	Analog Output	Analog output
AOP	Advanced Operator Panel	Advanced Operator Panel
APC	Advanced Positioning Control	Advanced Positioning Control
AR	Automatic Restart	Automatic restart
ASC	Armature Short-Circuit	Armature short-circuit
ASCII	American Standard Code for Information Interchange	American coding standard for the exchange of information
AS-i	AS-Interface (Actuator Sensor Interface)	AS-Interface (open bus system in automation technology)
ASM	Asynchronmotor	Induction motor
AVS	Active Vibration Suppression	Active load vibration damping
B		
BB	Betriebsbedingung	Operation condition
BERO	-	Contactless proximity switch
BI	Binector Input	Binector input
BIA	Berufsgenossenschaftliches Institut für Arbeitssicherheit	BG-Institute for Occupational Safety and Health
BICO	Binector Connector Technology	Binector connector technology
BLM	Basic Line Module	Basic Line Module
BO	Binector Output	Binector output
BOP	Basic Operator Panel	Basic Operator Panel
C		
C	Capacitance	Capacitance
C...	-	Safety message
CAN	Controller Area Network	Serial bus system
CBC	Communication Board CAN	Communication Board CAN
CBE	Communication Board Ethernet	PROFINET communication module (Ethernet)
CD	Compact Disc	Compact disc
CDS	Command Data Set	Command data set
CF Card	CompactFlash Card	CompactFlash card

Abbreviation	Derivation of abbreviation	Significance
CI	Connector Input	Connector input
CLC	Clearance Control	Clearance control
CNC	Computerized Numerical Control	Computer-supported numerical control
CO	Connector Output	Connector output
CO/BO	Connector Output/Binector Output	Connector output/Binector output
COB-ID	CAN Object-Identification	CAN object identification
CoL	Certificate of License	Certificate of License
COM	Common contact of a change-over relay	Center contact of a changeover contact
COMM	Commissioning	Startup
CP	Communication Processor	Communication processor
CPU	Central Processing Unit	Central processing unit
CRC	Cyclic Redundancy Check	Cyclic redundancy check
CSM	Control Supply Module	Control Supply Module
CU	Control Unit	Control Unit
CUA	Control Unit Adapter	Control Unit Adapter
CUD	Control Unit DC	Control Unit DC
D		
DAC	Digital Analog Converter	Digital analog converter
DC	Direct Current	DC current
DCB	Drive Control Block	Drive Control Block
DCBRK	DC Brake	DC braking
DCC	Drive Control Chart	Drive Control Chart
DCN	Direct Current Negative	Direct current negative
DCP	Direct Current Positive	Direct current positive
DDC	Dynamic Drive Control	Dynamic Drive Control
DDS	Drive Data Set	Drive data set
DI	Digital Input	Digital input
DI/DO	Digital Input/Digital Output	Digital input/output, bidirectional
DMC	DRIVE-CLiQ Hub Module Cabinet	DRIVE-CLiQ Hub Module Cabinet
DME	DRIVE-CLiQ Hub Module External	DRIVE-CLiQ Hub Module External
DMM	Double Motor Module	Double Motor Module
DO	Digital Output	Digital output
DO	Drive Object	Drive object
DP	Decentralized Peripherals	Distributed I/O
DPRAM	Dual Ported Random Access Memory	Dual-Port Random Access Memory
DQ	DRIVE-CLiQ	DRIVE-CLiQ
DRAM	Dynamic Random Access Memory	Dynamic Random Access Memory
DRIVE-CLiQ	Drive Component Link with IQ	Drive Component Link with IQ
DSC	Dynamic Servo Control	Dynamic Servo Control
DSM	Doppelsubmodul	Double submodule
DTC	Digital Time Clock	Timer

Abbreviation	Derivation of abbreviation	Significance
E		
EASC	External Armature Short-Circuit	External armature short-circuit
EDS	Encoder Data Set	Encoder data set
EEPROM	Electrically Erasable Programmable Read-Only Memory	Electrically Erasable Programmable Read-Only-Memory
EGB	Elektrostatisch gefährdete Baugruppen	Electrostatically sensitive devices
EIP	EtherNet/IP	EtherNet Industrial Protocol (realtime Ethernet)
ELCB	Earth Leakage Circuit Breaker	Residual current operated circuit breaker
ELP	Earth Leakage Protection	Ground-fault monitoring
EMC	Electromagnetic Compatibility	Electromagnetic compatibility
EMF	Electromotive Force	Electromotive force
EMK	Elektromotorische Kraft	Electromotive force
EMV	Elektromagnetische Verträglichkeit	Electromagnetic compatibility
EN	Europäische Norm	European standard
EnDat	Encoder-Data-Interface	Encoder interface
EP	Enable Pulses	Pulse enable
EPOS	Einfachpositionierer	Basic positioner
ES	Engineering System	Engineering system
ESB	Ersatzschaltbild	Equivalent circuit diagram
ESD	Electrostatic Sensitive Devices	Elektrostatisch gefährdete Baugruppen
ESM	Essential Service Mode	Essential service mode
ESR	Extended Stop and Retract	Extended stop and retract
F		
F...	Fault	Fault
FAQ	Frequently Asked Questions	Frequently asked questions
FBLOCKS	Free Blocks	Free function blocks
FCC	Function Control Chart	Function Control Chart
FCC	Flux Current Control	Flux current control
FD	Function Diagram	Function diagram
F-DI	Failsafe Digital Input	Fail-safe digital input
F-DO	Failsafe Digital Output	Fail-safe digital output
FEPROM	Flash-EPROM	Non-volatile write and read memory
FG	Function Generator	Function generator
FI	-	Fault current
FOC	Fiber-Optic Cable	Fiber-optic cable
FP	Funktionsplan	Function diagram
FPGA	Field Programmable Gate Array	Field Programmable Gate Array
FW	Firmware	Firmware
G		
GB	Gigabyte	Gigabyte
GC	Global Control	Global control telegram (broadcast telegram)

Abbreviation	Derivation of abbreviation	Significance
GND	Ground	Reference potential for all signal and operating voltages, usually defined as 0 V (also referred to as M)
GSD	Gerätstammdatei	Generic Station Description: Describes the features of a PROFIBUS slave
GSV	Gate Supply Voltage	Gate supply voltage
GUID	Globally Unique Identifier	Globally Unique Identifier
H		
HF	High frequency	High frequency
HFD	Hochfrequenzdrossel	Radio frequency reactor
HLA	Hydraulic Linear Actuator	Hydraulic linear actuator
HLG	Hochlaufgeber	Ramp-function generator
HM	Hydraulic Module	Hydraulic Module
HMI	Human Machine Interface	Human Machine Interface
HTL	High-Threshold Logic	Logic with high interference threshold
HW	Hardware	Hardware
I		
i. V.	In Vorbereitung	Under development: This property is currently not available
I/O	Input/Output	Input/output
I2C	Inter-Integrated Circuit	Internal serial data bus
IASC	Internal Armature Short-Circuit	Internal armature short-circuit
IBN	Inbetriebnahme	Startup
ID	Identifier	Identification
IE	Industrial Ethernet	Industrial Ethernet
IEC	International Electrotechnical Commission	International Electrotechnical Commission
IF	Interface	Interface
IGBT	Insulated Gate Bipolar Transistor	Insulated gate bipolar transistor
IGCT	Integrated Gate-Controlled Thyristor	Semiconductor power switch with integrated control electrode
IL	Impulslöschung	Pulse suppression
IP	Internet Protocol	Internet protocol
IPO	Interpolator	Interpolator
IT	Isolé Terre	Non-grounded three-phase line supply
IVP	Internal Voltage Protection	Internal voltage protection
J		
JOG	Jogging	Jogging
K		
KDV	Kreuzweiser Datenvergleich	Data cross-check
KHP	Know-how protection	Know-how protection
KIP	Kinetische Pufferung	Kinetic buffering
Kp	-	Proportional gain
KTY84	-	Temperature sensor

Abbreviation	Derivation of abbreviation	Significance
L		
L	-	Symbol for inductance
LED	Light Emitting Diode	Light emitting diode
LIN	Linearmotor	Linear motor
LR	Lageregler	Position controller
LSB	Least Significant Bit	Least significant bit
LSC	Line-Side Converter	Line-side converter
LSS	Line-Side Switch	Line-side switch
LU	Length Unit	Length unit
LWL	Lichtwellenleiter	Fiber-optic cable
M		
M	-	Symbol for torque
M	Masse	Reference potential for all signal and operating voltages, usually defined as 0 V (also referred to as GND)
MB	Megabyte	Megabyte
MCC	Motion Control Chart	Motion Control Chart
MDI	Manual Data Input	Manual data input
MDS	Motor Data Set	Motor data set
MLFB	Maschinenlesbare Fabrikatebezeichnung	Machine-readable product code
MM	Motor Module	Motor Module
MMC	Man-Machine Communication	Man-machine communication
MMC	Micro Memory Card	Micro memory card
MSB	Most Significant Bit	Most significant bit
MSC	Motor-Side Converter	Motor-side converter
MSCY_C1	Master Slave Cycle Class 1	Cyclic communication between master (class 1) and slave
MSR	Motorstromrichter	Motor-side converter
MT	Messtaster	Probe
N		
N. C.	Not Connected	Not connected
N...	No Report	No report or internal message
NAMUR	Interessengemeinschaft Automatisierungstechnik der Prozessindustrie	User Association of Automation Technology in Process Industries
NC	Normally Closed (contact)	NC contact
NC	Numerical Control	Numerical control
NEMA	National Electrical Manufacturers Association	Standardization association in USA (United States of America)
NM	Nullmarke	Zero mark
NO	Normally Open (contact)	NO contact
NSR	Netzstromrichter	Line-side converter
NTP	Network Time Protocol	Standard for synchronization of the time of day
NVRAM	Non-Volatile Random Access Memory	Non-volatile read/write memory

Abbreviation	Derivation of abbreviation	Significance
O		
OA	Open Architecture	Software component which provides additional functions for the SINAMICS drive system
OAIF	Open Architecture Interface	Version of the SINAMICS firmware as of which the OA-application can be used
OASP	Open Architecture Support Package	Extends the commissioning tool to include the corresponding OA-application
OC	Operating Condition	Operation condition
OCC	One Cable Connection	One-cable technology
OEM	Original Equipment Manufacturer	Original equipment manufacturer
OLP	Optical Link Plug	Bus connector for fiber-optic cable
OMI	Option Module Interface	Option Module Interface
P		
p...	-	Adjustable parameters
P1	Processor 1	Processor 1
P2	Processor 2	Processor 2
PB	PROFIBUS	PROFIBUS
PcCtrl	PC Control	Master control
PD	PROFIdrive	PROFIdrive
PDC	Precision Drive Control	Precision Drive Control
PDS	Power unit Data Set	Power unit data set
PDS	Power Drive System	Drive system
PE	Protective Earth	Protective ground
PELV	Protective Extra Low Voltage	Safety extra-low voltage
PFH	Probability of dangerous failure per hour	Probability of dangerous failure per hour
PG	Programmiergerät	Programming device
PI	Proportional Integral	Proportional integral
PID	Proportional Integral Differential	Proportional integral differential
PLC	Programmable Logical Controller	Programmable logic controller
PLL	Phase-Locked Loop	Phase-locked loop
PM	Power Module	Power Module
PMI	Power Module Interface	Power Module Interface
PMSM	Permanent-magnet synchronous motor	Permanent-magnet synchronous motor
PN	PROFINET	PROFINET
PNO	PROFIBUS Nutzerorganisation	PROFIBUS user organization
PPI	Point to Point Interface	Point-to-point interface
PRBS	Pseudo Random Binary Signal	White noise
PROFIBUS	Process Field Bus	Serial data bus
PS	Power Supply	Power supply
PSA	Power Stack Adapter	Power Stack Adapter
PT1000	-	Temperature sensor
PTC	Positive Temperature Coefficient	Positive temperature coefficient
PTP	Point To Point	Point-to-point

Abbreviation	Derivation of abbreviation	Significance
PWM	Pulse Width Modulation	Pulse width modulation
PZD	Prozessdaten	Process data
Q		
R		
r...	-	Display parameters (read only)
RAM	Random Access Memory	Memory for reading and writing
RCCB	Residual Current Circuit Breaker	Residual current operated circuit breaker
RCD	Residual Current Device	Residual current operated circuit breaker
RCM	Residual Current Monitor	Residual current monitor
REL	Reluctance motor textile	Reluctance motor textile
RESM	Reluctance synchronous motor	Synchronous reluctance motor
RFG	Ramp-Function Generator	Ramp-function generator
RJ45	Registered Jack 45	Term for an 8-pin socket system for data transmission with shielded or non-shielded multi-wire copper cables
RKA	Rückkühlanlage	Cooling unit
RLM	Renewable Line Module	Renewable Line Module
RO	Read Only	Read only
ROM	Read-Only Memory	Read-only memory
RPDO	Receive Process Data Object	Receive Process Data Object
RS232	Recommended Standard 232	Interface standard for a cable-connected serial data transmission between a transmitter and receiver (also known as EIA232)
RS485	Recommended Standard 485	Interface standard for a cable-connected differential, parallel, and/or serial bus system (data transmission between a number of transmitters and receivers, also known as EIA485)
RTC	Real Time Clock	Real-time clock
RZA	Raumzeigerapproximation	Space-vector approximation
S		
S1	-	Continuous duty
S3	-	Intermittent duty
SAM	Safe Acceleration Monitor	Safe acceleration monitoring
SBC	Safe Brake Control	Safe brake control
SBH	Sicherer Betriebshalt	Safe operating stop
SBR	Safe Brake Ramp	Safe brake ramp monitoring
SBT	Safe Brake Test	Safe brake test
SCA	Safe Cam	Safe cam
SCC	Safety Control Channel	Safety Control Channel
SCSE	Single Channel Safety Encoder	Single-channel safety encoder
SD Card	SecureDigital Card	Secure digital memory card
SDC	Standard Drive Control	Standard Drive Control
SDI	Safe Direction	Safe motion direction
SE	Sicherer Software-Endschalter	Safe software limit switch

Abbreviation	Derivation of abbreviation	Significance
SESM	Separately-excited synchronous motor	Separately excited synchronous motor
SG	Sicher reduzierte Geschwindigkeit	Safely-limited speed
SGA	Sicherheitsgerichteter Ausgang	Safety-related output
SGE	Sicherheitsgerichteter Eingang	Safety-related input
SH	Sicherer Halt	Safe stop
SI	Safety Integrated	Safety Integrated
SIC	Safety Info Channel	Safety Info Channel
SIL	Safety Integrity Level	Safety integrity level
SITOP	-	Siemens power supply system
SLA	Safely-Limited Acceleration	Safety limited acceleration
SLM	Smart Line Module	Smart Line Module
SLP	Safely-Limited Position	Safely-limited position
SLS	Safely-Limited Speed	Safely-limited speed
SLVC	Sensorless Vector Control	Sensorless vector control
SM	Sensor Module	Sensor Module
SMC	Sensor Module Cabinet	Sensor Module Cabinet
SME	Sensor Module External	Sensor Module External
SMI	SINAMICS Sensor Module Integrated	SINAMICS Sensor Module Integrated
SMM	Single Motor Module	Single Motor Module
SN	Sicherer Software-Nocken	Safe software cam
SOS	Safe Operating Stop	Safe operating stop
SP	Service Pack	Service pack
SP	Safe Position	Safe position
SPC	Setpoint Channel	Setpoint channel
SPI	Serial Peripheral Interface	Serial peripheral interface
SPS	Speicherprogrammierbare Steuerung	Programmable logic controller
SS1	Safe Stop 1	Safe Stop 1 (time-monitored, ramp-monitored)
SS1E	Safe Stop 1 External	Safe Stop 1 with external stop
SS2	Safe Stop 2	Safe Stop 2
SS2E	Safe Stop 2 External	Safe Stop 2 with external stop
SSI	Synchronous Serial Interface	Synchronous serial interface
SSL	Secure Sockets Layer	Encryption protocol for secure data transfer (new TLS)
SSM	Safe Speed Monitor	Safe feedback from speed monitor
SSP	SINAMICS Support Package	SINAMICS support package
STO	Safe Torque Off	Safe torque off
STW	Steuerwort	Control word
T		
TB	Terminal Board	Terminal Board
TEC	Technology Extension	Software component which is installed as an additional technology package and which expands the functionality of SINAMICS (previously OA-application)

Abbreviation	Derivation of abbreviation	Significance
TIA	Totally Integrated Automation	Totally Integrated Automation
TLS	Transport Layer Security	Encryption protocol for secure data transfer (previously SSL)
TM	Terminal Module	Terminal Module
TN	Terre Neutre	Grounded three-phase line supply
Tn	-	Integral time
TPDO	Transmit Process Data Object	Transmit Process Data Object
TSN	Time-Sensitive Networking	Time-Sensitive Networking
TT	Terre Terre	Grounded three-phase line supply
TTL	Transistor-Transistor-Logic	Transistor-transistor logic
Tv	-	Rate time
U		
UL	Underwriters Laboratories Inc.	Underwriters Laboratories Inc.
UPS	Uninterruptible Power Supply	Uninterruptible power supply
USV	Unterbrechungsfreie Stromversorgung	Uninterruptible power supply
UTC	Universal Time Coordinated	Universal time coordinated
V		
VC	Vector Control	Vector control
Vdc	-	DC-link voltage
VdcN	-	Partial DC-link voltage negative
VdcP	-	Partial DC-link voltage positive
VDE	Verband Deutscher Elektrotechniker	Association of German Electrical Engineers
VDI	Verein Deutscher Ingenieure	Association of German Engineers
VPM	Voltage Protection Module	Voltage Protection Module
Vpp	Volt peak to peak	Volt peak to peak
VSM	Voltage Sensing Module	Voltage Sensing Module
W		
WEA	Wiedereinschaltautomatik	Automatic restart
WZM	Werkzeugmaschine	Machine tool
X		
XML	Extensible Markup Language	Extensible markup language (standard language for Web publishing and document management)
Y		
Z		
ZK	Zwischenkreis	DC link
ZM	Zero Mark	Zero mark
ZSW	Zustandswort	Status word

Index

Numbers

- 1020
 - Explanation of the symbols (part 1), 499
- 1021
 - Explanation of the symbols (part 2), 500
- 1022
 - Explanation of the symbols (part 3), 501
- 1030
 - Handling BICO technology, 502
- 2201
 - Connection overview, 504
- 2220
 - Digital inputs, electrically isolated (DI 0 ... DI 3), 505
- 2230
 - Digital inputs/outputs, bidirectional (DI/DO 24 ... DI/DO 25), 506
- 2251
 - Motor speed potentiometers 1 and 2, 507
- 2272
 - Two-wire control, 508
- 2273
 - Three-wire control, 509
- 2280
 - Quick commissioning using DIP switch, 510
- 2381
 - Control commands and interrogation commands, 512
- 2382
 - States, 513
- 2401
 - PROFIdrive overview, 515
- 2410
 - PROFIBUS, EtherNet/IP - addresses and diagnostics, 516
- 2420
 - PROFIdrive - telegrams and process data (PZD), 517
- 2440
 - PROFIdrive - PZD receive signals interconnection, 518
- 2441
 - PROFIdrive - STW1 control word interconnection (p2038 = 2), 519
- 2442
 - PROFIdrive - STW1 control word interconnection (p2038 = 0), 520
- 2444
 - PROFIdrive - STW2 control word interconnection (p2038 = 0), 521
- 2446
 - PROFIdrive - STW3 control word interconnection, 522
- 2448
 - PROFIdrive - STW_G115D control word interconnection, 523
- 2450
 - PROFIdrive - PZD send signals interconnection, 524
- 2451
 - PROFIdrive - ZSW1 status word interconnection (p2038 = 2), 525
- 2452
 - PROFIdrive - ZSW1 status word interconnection (p2038 = 0), 526
- 2454
 - PROFIdrive - ZSW2 status word interconnection (p2038 = 0), 527
- 2456
 - PROFIdrive - ZSW3 status word interconnection, 528
- 2458
 - PROFIdrive - ZSW_G115D status word interconnection, 529
- 2468
 - PROFIdrive - receive telegram, free interconnection via BICO (p0922 = 999), 530
- 2470
 - PROFIdrive - send telegram, free interconnection via BICO (p0922 = 999), 531
- 2472
 - PROFIdrive - status words, free interconnection, 532
- 2473
 - EtherNet/IP - control word / status word interconnection, 533
- 2501
 - Control word sequence control (r0898), 542
- 2503
 - Status word sequence control (r0899), 543
- 2505
 - Control word setpoint channel (r1198), 544
- 2507
 - Status word key status (r8559), 545
- 2510
 - Status word 1 (r0052), 546
- 2511
 - Status word 2 (r0053), 547
- 2512
 - Control word 1 (r0054), 548

- 2513
 - Supplementary control word (r0055), 549
- 2520
 - Control word speed controller (r1406), 550
- 2522
 - Status word speed controller (r1407), 551
- 2526
 - Status word closed-loop control (r0056), 552
- 2530
 - Status word current control (r1408), 553
- 2534
 - Status word monitoring functions 1 (r2197), 554
- 2536
 - Status word monitoring functions 2 (r2198), 555
- 2537
 - Status word monitoring functions 3 (r2199), 556
- 2546
 - Control word faults/alarms (r2138), 557
- 2548
 - Status word faults/alarms 1 and 2 (r2139 and r2135), 558
- 2610
 - Sequence control - Sequencer, 559
- 2634
 - Sequence control - Missing enable signals, 560
- 2701
 - Basic brake control, 562
- 2800
 - Parameter manager, 564
- 2802
 - Monitoring functions and faults/alarms, 565
- 2804
 - Status words, 566
- 2810
 - STO (Safe Torque Off), 567
- 2813
 - F-DI (Fail-safe Digital Input), 568
- 2915
 - Standard telegrams (PROFIsafe), 570
- 2917
 - Manufacturer-specific telegrams, 571
- 3001
 - Overview of setpoint channel, 573
- 3010
 - Fixed speed setpoints, binary selection (p1016 = 2), 574
- 3011
 - Fixed speed setpoints, direct selection (p1016 = 1), 575
- 3020
 - Motorized potentiometer, 576
- 3030
 - Main/supplementary setpoint, setpointscaling, jogging, 577
- 3040
 - Direction limitation and direction reversal, 578
- 3050
 - Skip frequency bands and speed limitations, 579
- 3060
 - Basic ramp-function generator, 580
- 3070
 - Extended ramp-function generator, 581
- 3080
 - Ramp-function generator selection, -status word, -tracking, 582
- 4704
 - Position sensing encoder 1, 584
- 6020
 - Closed-loop speed control and generation of the torque limits, overview, 587
- 6030
 - Speed setpoint, droop, 588
- 6031
 - Precontrol symmetrization, acceleration model, 589
- 6035
 - Moment of inertia estimator, 590
- 6040
 - Speed controller, 591
- 6050
 - Kp_n-/Tn_n adaptation, 592
- 6060
 - Torque setpoint, 593
- 6220
 - Vdc_max controller and Vdc_min controller (vector control), 594
- 6300
 - U/f control, overview, 595
- 6301
 - U/f control, characteristic and voltage boost, 596
- 6310
 - U/f control, resonance damping and slip compensation, 597
- 6320
 - U/f control, Vdc_max controller, 598
- 6490
 - Speed control configuration, 599
- 6491
 - Flux controller configuration, 600
- 6630
 - Upper/lower torque limit, 601
- 6640
 - Current/power/torque limits, 602
- 6700
 - Current control, overview, 603
- 6710
 - Current setpoint filter, 604
- 6714
 - Iq and Id controllers, 605

- 6721
 Id setpoint (PMSM, p0300 = 2), 606
- 6722
 Field weakening characteristic, flux setpoint (ASM, p0300 = 1), 607
- 6723
 Field weakening controller, flux controller, Id setpoint (ASM, p0300 = 1), 608
- 6724
 Field weakening controller (PMSM, p0300 = 2xx), 609
- 6730
 Interface to the Power Module (ASM, p0300 = 1), 610
- 6731
 Interface to the Power Module (PMSM, p0300 = 2xx), 611
- 6790
 Flux setpoint (RESM, p0300 = 6xx), 612
- 6791
 Id setpoint (RESM, p0300 = 6xx), 613
- 6792
 Interface to the Power Module (RESM, p0300 = 6xx), 614
- 6799
 Display signals, 615
- 7010
 Friction characteristic, 617
- 7017
 DC braking (ASM, p0300 = 1), 618
- 7040
 Conveyor, 1 direction/ 1 Speed (p3391 = 1), 620
- 7041
 Conveyor, 1 Direction / 2 Speeds (p3393 = 2), 621
- 7042
 Conveyor, 2 Directions / 1 Speed (p3393 = 3), 622
- 7043
 Conveyor, 2 Directions / 2 Speeds (p3393 = 4), 623
- 7044
 Turntable, 2 Positions / 1 Speed (p3393 = 5), 624
- 7045
 Turntable, 2 Positions / 2 Speeds (p3393 = 6), 625
- 7046
 Turntable, 3 Positions / 1 Speed (p3393 = 7), 626
- 7047
 Turntable 3 Positions / 2 Speeds (p3393 = 8), 627
- 7048
 Corner turntable lift, 2 Positions / 1 Speed (p3393 = 9), 628
- 7049
 Corner turntable lift, 2 Positions / 2 Speeds (p3393 = 10), 629
- 7050
 Travelling Trolley, 1 Speed (p3393 = 11), 630
- 7051
 Travelling Trolley, 2 Speeds (p3393 = 12), 631
- 7200
 Sampling times of the runtime groups, 633
- 7210
 AND 0 ... 3, 634
- 7212
 OR 0 ... 3, 635
- 7214
 XOR 0 ... 3, 636
- 7216
 NOT 0 ... 5, 637
- 7220
 ADD 0 ... 2, SUB 0 ... 1, 638
- 7222
 MUL 0 ... 1, DIV 0 ... 1, 639
- 7224
 AVA 0 ... 1, 640
- 7225
 NCM 0 ... 1, 641
- 7226
 PLI 0 ... 1, 642
- 7230
 MFP 0 ... 3, PCL 0 ... 1, 643
- 7232
 PDE 0 ... 3, 644
- 7233
 PDF 0 ... 3, 645
- 7234
 PST 0 ... 1, 646
- 7240
 RSR 0 ... 2, DFR 0 ... 2, 647
- 7250
 BSW 0 ... 1, NSW 0 ... 1, 648
- 7260
 LIM 0 ... 1, 649
- 7262
 PT1 0 ... 1, 650
- 7264
 INT 0, DIF 0, 651
- 7270
 LVM 0 ... 1, 652
- 7950
 Fixed value selection binary (p2216 = 2), 654
- 7951
 Fixed value selection direct (p2216 = 1), 655
- 7954
 Motorized potentiometer, 656
- 7958
 Closed-loop control, 657
- 8005
 Overview, signals and monitoring functions, 659
- 8010
 Speed signals 1, 660

8011
Speed signals 2, 661

8012
Torque signals, motor blocked/stalled, 662

8013
Load monitoring (Part 1), 663

8014
Load monitoring (Part 2), 664

8016
Thermal monitoring motor, motor temperature status word faults/alarms, 665

8017
Motor temperature model 1 (I2t), 666

8018
Motor temperature model 2, 667

8021
Thermal monitoring, power unit, 668

8022
Monitoring functions 1, 669

8023
Monitoring functions 2, 670

8050
Diagnostics overview, 672

8060
Fault buffer, 673

8065
Alarm buffer, 674

8070
Faults/alarms trigger word (r2129), 675

8075
Faults/alarms configuration, 676

8560
Command Data Sets (CDS), 678

8565
Drive Data Sets (DDS), 679

9430
Configuration, addresses and diagnostics, 535

9431
Interconnection overview, 536

9435
STW1 control word interconnection (p0015 = 30/31/34), 537

9438
STW3 control word interconnection, 538

9445
ZSW1 status word interconnection, 539

9455
Fixed speed setpoints (p0015 = 30/31, p1016 = 2), 540

A

Acknowledgment
Adjustable, 690
Default, 690
IMMEDIATELY, 685
POWER ON, 685
PULSE SUPPRESSION, 685

Address
Technical Support, 6

Adjustable parameters, 17

Alarm
Cause, 690
Display, 682
Explanation of list, 686
Fault location, 687
General, 682
How to distinguish an alarm from a fault, 682
List of all alarms, 693
Message class, 687
Name, 687
Number, 686
Number range, 691
Remedy, 690

Alarm value, 690

ASCII table, 792

Axxxx, 686

B

BI, Binector Input, 18

BICO technology, 502

Binector
Input (BI), 18
Output (BO), 18

Bit field (parameter), 25

BO, Binector Output, 18

Brake control, 561

C

Calculated, 19

Can be changed (parameters), 21

CDS (Command Data Set), 22, 678

CI, Connector Input, 18

Closed-loop control
Technology controller, 657
Vector, 585

CO, Connector Output, 18

CO/BO, Connector/Binector Output, 18

Command data sets, 677

Connector
Input (CI), 18
Output (CO), 18

Control
U/f, 585

- D**
- Data protection, 7
 - Data Set, 677
 - Command Data Set, CDS, 22
 - Drive Data Set, DDS, 22
 - Data set, 677
 - Command data set, 22
 - Drive data set, 22
 - Data sets, 677
 - Data type (parameters), 20
 - DCBRK, 684
 - DDS (Drive Data Set), 22, 679
 - Dependency (parameter), 25
 - Description (parameter), 24
 - Diagnostics, 671
 - Directory
 - ASCII table, 792
 - Complete table of contents, 9
 - Function diagram list, brake control, 561
 - Function diagram list, data sets, 677
 - Function diagram list, diagnostics, 671
 - Function diagram list, encoder evaluation, 583
 - Function diagram list, explanations of the function diagrams, 498
 - Function diagram list, fieldbus interface (AS-Interface), 534
 - Function diagram list, free function blocks, 632
 - Function diagram list, input/output terminals, DIP switch, 503
 - Function diagram list, internal control/status words, 541
 - Function diagram list, PROFIdrive, Ethernet/IP, 514
 - Function diagram list, PROFIenergy, 511
 - Function diagram list, Safety Integrated Basic Functions, 563
 - Function diagram list, Safety Integrated PROFIsafe, 569
 - Function diagram list, setpoint channel, 572
 - Function diagram list, signals and monitoring functions, 658
 - Function diagram list, technology controller, 653
 - Function diagram list, technology functions, 616, 619
 - Function diagram list, vector control / U/f control, 585
 - Index, 805
 - List of abbreviations, 795
 - Table of contents, function diagrams, 492
 - Display
 - Alarms, 682
 - Faults, 682
 - Display parameters, 17
 - Drive data sets, 677
 - Dynamic index (parameters), 22
- E**
- EC Declaration of Conformity, 7
 - Encoder data sets, 677
 - Encoder evaluation, 583
 - Ethernet/IP, 514
 - Explanations of the function diagrams, 498
- F**
- Factory setting, 24
 - Fault
 - Acknowledgment, 685, 690
 - Cause, 690
 - Display, 682
 - Explanation of list, 686
 - Fault location, 687
 - Fault reaction, 683, 690
 - General, 682
 - How to distinguish a fault from an alarm, 682
 - List of all faults, 693
 - Message class, 687
 - Name, 687
 - Number, 686
 - Number range, 691
 - Remedy, 690
 - Fault buffer
 - Configuration, 673
 - Fault value, 690
 - Fieldbus interface (AS-Interface), 534
 - Fixed values, 654, 655
 - Free function blocks, 632
 - Friction characteristic, 617
 - Function diagram (parameters), 23
 - Function diagrams brake control
 - Basic brake control, 562
 - Function diagrams conveyor technology application
 - Conveyor, 1 Direction / 2 Speeds (p3393 = 2), 621
 - Conveyor, 1 direction/ 1 Speed (p3391 = 1), 620
 - Conveyor, 2 Directions / 1 Speed (p3393 = 3), 622
 - Conveyor, 2 Directions / 2 Speeds (p3393 = 4), 623
 - Corner turntable lift, 2 Positions / 1 Speed (p3393 = 9), 628
 - Corner turntable lift, 2 Positions / 2 Speeds (p3393 = 10), 629
 - Travelling Trolley, 1 Speed (p3393 = 11), 630
 - Travelling Trolley, 2 Speeds (p3393 = 12), 631
 - Turntable 3 Positions / 2 Speeds (p3393 = 8), 627
 - Turntable, 2 Positions / 1 Speed (p3393 = 5), 624
 - Turntable, 2 Positions / 2 Speeds (p3393 = 6), 625
 - Turntable, 3 Positions / 1 Speed (p3393 = 7), 626
 - Function diagrams data sets
 - Command Data Sets (CDS), 678
 - Drive Data Sets (DDS), 679

- Function diagrams diagnostics
 - Alarm buffer, 674
 - Fault buffer, 673
 - Faults/alarms configuration, 676
 - Faults/alarms trigger word (r2129), 675
 - Overview, 672
- Function diagrams encoder evaluation
 - Position sensing encoder 1, 584
- Function diagrams fieldbus interface (AS-i)
 - Configuration, addresses and diagnostics, 535
 - Fixed speed setpoints (p0015 = 30/31, p1016 = 2), 540
 - Interconnection overview, 536
 - STW1 control word interconnection (p0015 = 30/31/34), 537
 - STW3 control word interconnection, 538
 - ZSW1 status word interconnection, 539
- Function diagrams free function blocks
 - ADD 0 ... 2, 638
 - AND 0 ... 3, 634
 - AVA 0 ... 1, 640
 - BSW 0 ... 1, 648
 - DFR 0 ... 2, 647
 - DIF 0, 651
 - DIV 0 ... 1, 639
 - INT 0, 651
 - LIM 0 ... 1, 649
 - LVM 0 ... 1, 652
 - MFP 0 ... 3, 643
 - MUL 0 ... 1, 639
 - NCM 0 ... 1, 641
 - NOT 0 ... 5, 637
 - NSW 0 ... 1, 648
 - OR 0 ... 3, 635
 - PCL 0 ... 1, 643
 - PDE 0 ... 3, 644
 - PDF 0 ... 3, 645
 - PLI 0 ... 1, 642
 - PST 0 ... 1, 646
 - PT1 0 ... 1, 650
 - RSR 0 ... 2, 647
 - Sampling times of the runtime groups, 633
 - SUB 0 ... 1, 638
 - XOR 0 ... 3, 636
- Function diagrams general information
 - Explanation of the symbols (part 1), 499
 - Explanation of the symbols (part 2), 500
 - Explanation of the symbols (part 3), 501
 - Handling BICO technology, 502
- Function diagrams input/output terminals, DIP switch
 - Connection overview, 504
 - Digital inputs, electrically isolated (DI 0 ... DI 3), 505
 - Digital inputs/outputs, bidirectional (DI/DO 24 ... DI/DO 25), 506
 - Motor speed potentiometers 1 and 2, 507
 - Quick commissioning using DIP switch, 510
 - Three-wire control, 509
 - Two-wire control, 508
- Function diagrams internal control/status words
 - Control word faults/alarms (r2138), 557
 - Control word sequence control (r0898), 542
 - Control word setpoint channel (r1198), 544
 - Control word speed controller (r1406), 550
 - Control word 1 (r0054), 548
 - Sequence control - Missing enable signals, 560
 - Sequence control - Sequencer, 559
 - Status word closed-loop control (r0056), 552
 - Status word current control (r1408), 553
 - Status word faults/alarms 1 and 2 (r2139 and r2135), 558
 - Status word key status (r8559), 545
 - Status word monitoring functions 1 (r2197), 554
 - Status word monitoring functions 2 (r2198), 555
 - Status word monitoring functions 3 (r2199), 556
 - Status word sequence control (r0899), 543
 - Status word speed controller (r1407), 551
 - Status word 1 (r0052), 546
 - Status word 2 (r0053), 547
 - Supplementary control word (r0055), 549
- Function diagrams PROFIdrive, EtherNet/IP
 - EtherNet/IP - control word / status word interconnection, 533
 - Overview, 515
 - PROFIdrive - PZD receive signals interconnection, 518
 - PROFIdrive - PZD send signals interconnection, 524
 - PROFIdrive - receive telegram, free interconnection via BICO (p0922 = 999), 530
 - PROFIdrive - send telegram, free interconnection via BICO (p0922 = 999), 531
 - PROFIdrive - status words, free interconnection, 532
 - PROFIdrive - STW_G115D control word interconnection, 523
 - PROFIdrive - STW1 control word interconnection (p2038 = 0), 520
 - PROFIdrive - STW1 control word interconnection (p2038 = 2), 519
 - PROFIdrive - STW2 control word interconnection (p2038 = 0), 521
 - PROFIdrive - STW3 control word interconnection, 522
 - PROFIdrive - telegrams and process data (PZD), 517
 - PROFIdrive - ZSW_G115D status word interconnection, 529
 - PROFIdrive - ZSW1 status word interconnection (p2038 = 0), 526
 - PROFIdrive - ZSW1 status word interconnection (p2038 = 2), 525

- PROFIdrive - ZSW2 status word interconnection (p2038 = 0), 527
 - PROFIdrive - ZSW3 status word interconnection, 528
 - PROFIdrive, EtherNet/IP - addresses and diagnostics, 516
 - Function diagrams PROFInergy
 - Control commands and interrogation commands, 512
 - States, 513
 - Function diagrams Safety Integrated Basic Functions
 - F-DI (Fail-safe Digital Input), 568
 - Monitoring functions and faults/alarms, 565
 - Parameter manager, 564
 - Status words, 566
 - STO (Safe Torque Off), 567
 - Function diagrams Safety Integrated PROFIsafe
 - Manufacturer-specific telegrams, 571
 - Standard telegrams, 570
 - Function diagrams setpoint channel
 - Basic ramp-function generator, 580
 - Direction limitation and direction reversal, 578
 - Extended ramp-function generator, 581
 - Fixed speed setpoints, binary selection (p1016 = 2), 574
 - Fixed speed setpoints, direct selection (p1016 = 1), 575
 - Main/supplementary setpoint, setpointscaling, jogging, 577
 - Motorized potentiometer, 576
 - Overview, 573
 - Ramp-function generator selection, -status word, -tracking, 582
 - Skip frequency bands and speed limitations, 579
 - Function diagrams signals and monitoring functions
 - Load monitoring (Part 1), 663
 - Load monitoring (Part 2), 664
 - Monitoring functions 1, 669
 - Monitoring functions 2, 670
 - Motor temperature model 1 (I2t), 666
 - Motor temperature model 2, 667
 - Overview, 659
 - Speed signals 1, 660
 - Speed signals 2, 661
 - Thermal monitoring motor, motor temperature status word faults/alarms, 665
 - Thermal monitoring, power unit, 668
 - Torque signals, motor blocked/stalled, 662
 - Function diagrams technology controller
 - Closed-loop control, 657
 - Fixed value selection binary (p2216 = 2), 654
 - Fixed value selection direct (p2216 = 1), 655
 - Motorized potentiometer, 656
 - Function diagrams technology functions
 - DC braking (ASM, p0300 = 1), 618
 - Friction characteristic, 617
 - Function diagrams vector control / U/f control
 - Closed-loop speed control and generation of the torque limits, overview, 587
 - Current control, overview, 603
 - Current setpoint filter, 604
 - Current/power/torque limits, 602
 - Display signals, 615
 - Field weakening characteristic, flux setpoint (ASM, p0300 = 1), 607
 - Field weakening controller, flux controller, Id setpoint (ASM, p0300 = 1), 608
 - Flux controller configuration, 600
 - Flux setpoint (RESM, p0300 = 6xx), 612
 - Id setpoint (RESM, p0300 = 6xx), 613
 - Interface to the Power Module (ASM, p0300 = 1), 610
 - Interface to the Power Module (RESM, p0300 = 6xx), 614
 - Iq and Id controllers, 605
 - Kp_n-/Tn_n adaptation, 592
 - Moment of inertia estimator, 590
 - Precontrol symmetrization, acceleration model, 589
 - Speed control configuration, 599
 - Speed controller, 591
 - Speed setpoint, droop, 588
 - Torque setpoint, 593
 - U/f control, characteristic and voltage boost, 596
 - U/f control, overview, 595
 - U/f control, resonance damping and slip compensation, 597
 - U/f control, Vdc_max controller, 598
 - Upper/lower torque limit, 601
 - Vdc_max controller and Vdc_min controller, 594
 - Function diagrams, vector control
 - Field weakening controller (PMSM, p0300 = 2xx), 609
 - Id setpoint (PMSM, p0300 = 2), 606
 - Interface to the Power Module (PMSM, p0300 = 2xx), 611
 - Fxxxx, 686
- ## G
- General
 - About parameters, 16
 - on faults and alarms, 682
 - on function diagrams, 498
- ## H
- Hotline, 6

I

IASC, 684
 Index
 Parameter, 17
 Index (parameters), 24
 Industrial security, 13
 Input/output terminals, DIP switch, 503
 Internal control words, 541
 Internal control/status words, 541

J

Jogging, 577

L

Linked parameters, 17
 List
 Abbreviations, 795
 ASCII table, 792
 Binector inputs (BI parameters), 476
 Binector outputs (BO parameters), 480
 Command data sets, 465
 Connector inputs (CI parameters), 478
 Connector outputs (CO parameters), 481
 Connector/binector outputs (CO/BO parameters), 485
 Drive data sets, 467
 Faults and alarms, 693
 Message ranges, 691
 Parameter ranges, 26
 Parameters for quick commissioning, 489
 Parameters for write protection and know-how protection, 487
 Parameters, all, 29
 List of abbreviations, 795

M

Message class, 687
 Motorized potentiometer, 656

N

Name
 Alarm, 687
 Fault, 687
 Normalization, 21
 Notes
 Hotline, 6
 Product information, 5
 Technical Support, 6
 Number
 Alarm, 686
 Fault, 686
 Parameter, 17

Number range

 Alarms, 691
 Faults, 691
 Parameters, 26

Number ranges of faults and alarms, 691

O

OFF1, 683
 OFF1_DELAYED, 683
 OFF2, 683
 OFF3, 684

P

Parameter
 Bit field, 25
 Calculated, 19
 Command data sets, 465
 CU variants, 18
 Dependency, 25
 Description, 24
 Drive data sets, 467
 Dynamic index, 22
 Full name, 18
 Function diagram, 23
 Index, 17, 24
 Linked parameters, 17
 List for quick commissioning, 489
 List of all parameters, 29
 List of the binector inputs, 476
 List of the binector outputs, 480
 List of the connector inputs, 478
 List of the connector outputs, 481
 List of the connector/binector outputs, 485
 Normalization, 21
 Number, 17
 Parameter values, 24
 Recommendation, 24
 Safety guidelines, 25
 Short name, 18
 Values, 24
 Parameters
 Access level, 19
 Can be changed, 21
 Data type, 20
 Number range, 26
 Unit group, 22
 Unit selection, 22
 Password for access level 4, 19
 Product information, 5
 PROFIBUS, 514
 PROFIdrive, 514
 PROFIenergy, 511
 PROFINET, 514
 pxxxx, 17

Q

Quick commissioning (parameters), 489

R

Reaction to faults, 683

Resetting faults, 690

rxxxx, 17

S

Safety instructions

 Fundamental, 11

 General, 12

 Industrial security, 13

Safety instructions (parameter), 25

Safety Integrated

 Basic Functions, 563

Safety Integrated PROFIsafe, 569

Search tools for this manual, 6

Setpoint channel, 572

Signals and monitoring functions, 658

Status words

 Internal, 541

STOP2, 684

Support, 6

Support Request, 6

T

Target group, 6

Technical Support, 6

Technology controller, 653

Technology functions, 616, 619

U

U/f control, 585

Unit (parameter), 22

V

Values (parameter), 24

Vector control, 585

Version

 List of all parameters, 29

 List of faults and alarms, 693

Siemens AG
Digital Industries
Motion Control
Postfach 3180
91050 ERLANGEN
GERMANY

Scan the QR code for
additional
information about
SINAMICS G115D.

