

SIEMENS



SINAMICS G180

Converters – Compact Units, Cabinet Systems,
Cabinet Units Air-Cooled







Motion Control Drives

Catalog
D 18.1

Edition
2014

Answers for industry.

Related catalogs

<p>SINAMICS G130 Drive Converter Chassis Units</p> <p>SINAMICS G150 Drive Converter Cabinet Units</p> <p>E86060-K5511-A101-A6-7600</p>	<p>D 11</p> 
<p>SINAMICS S120 Chassis Format Converter Units Chassis-2 Format Converter Units Cabinet Modules, Cabinet Modules-2</p> <p>SINAMICS S150 Converter Cabinet Units</p> <p>E86060-K5521-A131-A8-7600</p>	<p>D 21.3</p> 
<p>Motion Control Drives SINAMICS S120 and SIMOTICS</p> <p>E86060-K5521-A141-A1-7600</p>	<p>D 21.4</p> 
<p>Motion Control Drives SINAMICS Converters for Single-Axis Drives Built-In Units</p> <p>E86060-K5531-A111-A4-7600</p>	<p>D 31.1</p> 
<p>Motion Control Drives SINAMICS Converters for Single-Axis Drives Distributed Converters</p> <p>E86060-K5531-A121-A3-7600</p>	<p>D 31.2</p> 
<p>Low-Voltage Power Distribution and Electrical Installation Technology SENTRON • SIVACON • ALPHA</p> <p>PDF (E86060-K8280-A101-B7-7600)</p>	<p>LV 10</p> 
<p>SiePortal Information and Ordering Platform on the Internet:</p> <p>sieportal.siemens.com</p>	

Motion Control Drives

SINAMICS G180

Converters – Compact Units, Cabinet Systems, Cabinet Units

Catalog D 18.1 · 2014



The products and systems described in this catalog are manufactured/distributed under application of a certified quality management system in accordance with DIN EN ISO 9001 (Certified Registration No. 002241 QM08). The certificate is recognized by all IQNet countries.

Supersedes:
Catalog D 18.1 · 2013 (PDF)

Refer to SiePortal for current updates of
this catalog:
sieportal.siemens.com

Please contact your local Siemens branch

© Siemens AG 2023

Introduction	1
SINAMICS G180 compact units and SINAMICS G180 cabinet systems	2
SINAMICS G180 cabinet units Cabinet units air-cooled	3
Option descriptions Standard options, Inspection option, Engineer To Order – ETO	4
Configuring instructions Functions, Characteristic curves, Standard interface, Communication, Type plate, Supplementary Supply Agree- ments, Engineering and commissioning tools, Siemens Product Configurator	5
Services and documentation Customer training, Commissioning, Maintenance, Inspection, Repairs, Spare parts, Remote maintenance, Documentation, Service & Support, Industry Services, Online Services	6
Appendix Partners at Siemens, Online Services, Conditions of sale and delivery, Export regulations	7

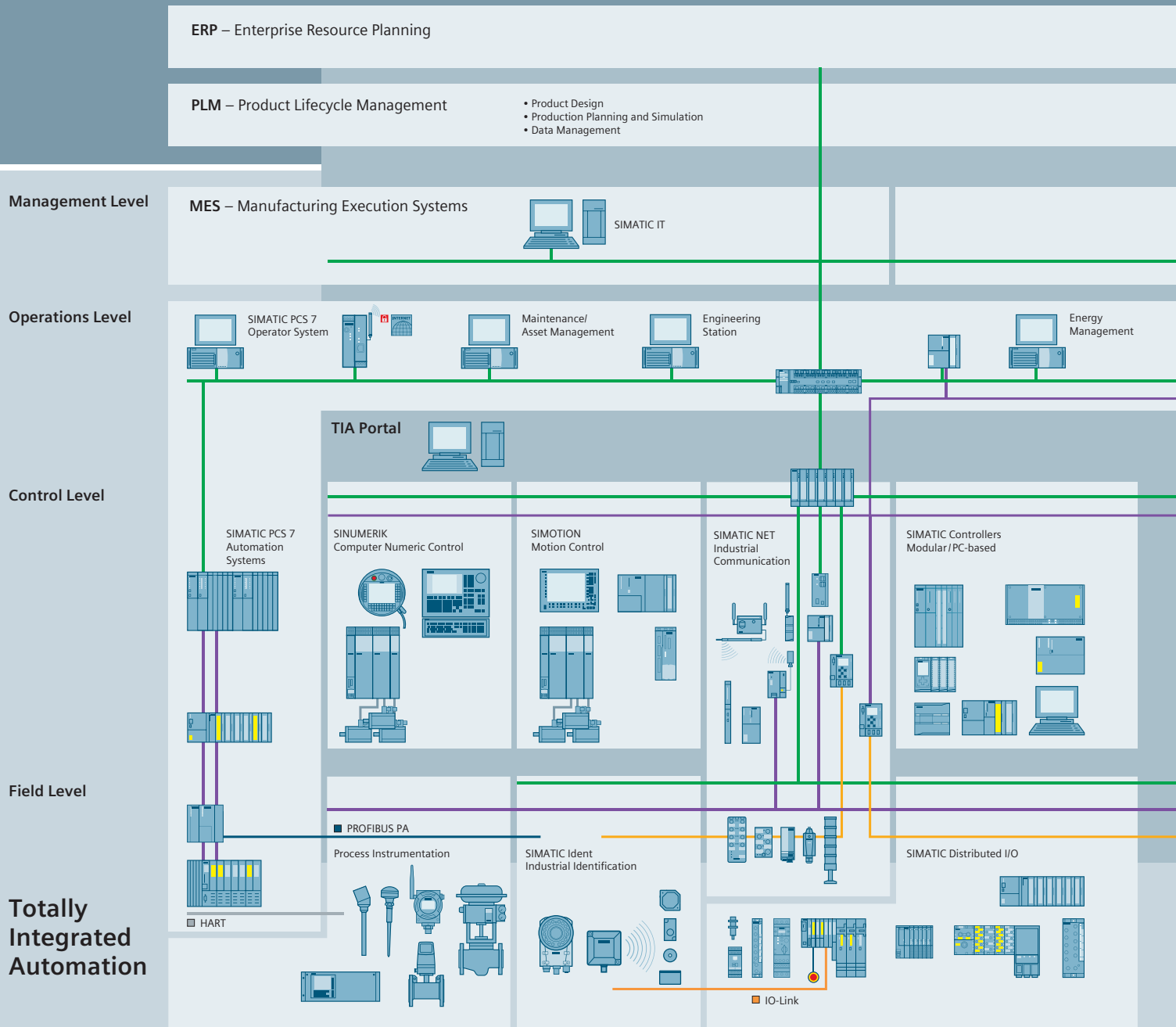

Setting standards in productivity and competitiveness.

Totally Integrated Automation.

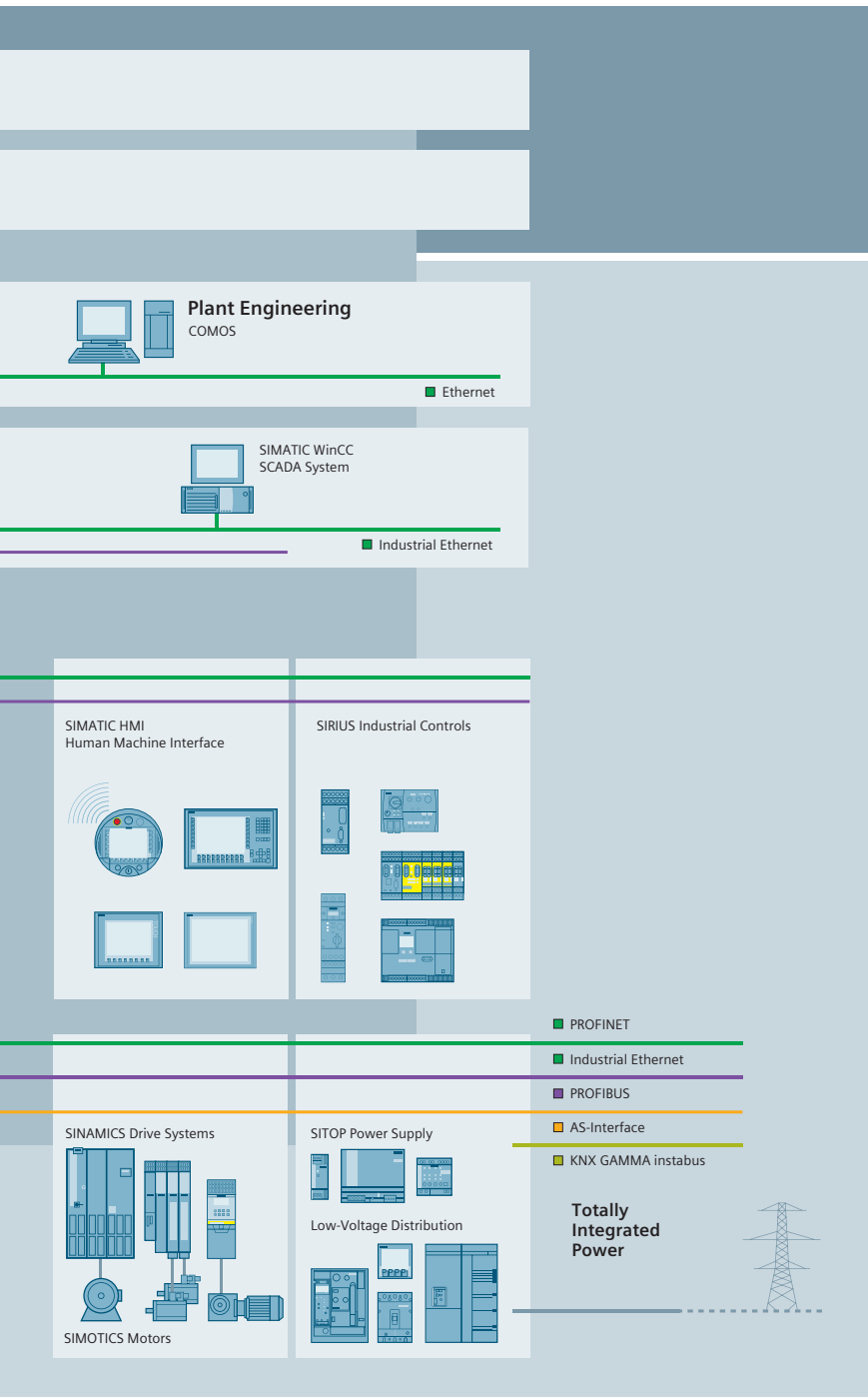

TIA is characterized by its unique continuity.

It provides maximum transparency at all levels with reduced interfacing requirements – covering the field level, production control level, up to the corporate management level. With TIA you also profit throughout the complete life cycle of your plant – starting with the initial planning steps through operation up to modernization, where we offer a high measure of investment security resulting from continuity in the further development of our products and from reducing the number of interfaces to a minimum.

The unique continuity is already a defined characteristic at the development stage of our products and systems.

The result: maximum interoperability – covering the controller, HMI, drives, up to the process control system. This reduces the complexity of the automation solution in your plant. You will experience this, for example, in the engineering phase of the automation solution in the form of reduced time requirements and cost, or during operation using the continuous diagnostics facilities of Totally Integrated Automation for increasing the availability of your plant.

Thanks to Totally Integrated Automation, Siemens provides an integrated basis for the implementation of customized automation solutions – in all industries from inbound to outbound.



**Totally Integrated Power:
Future-proof power supply
from one source.**

Software tools, products, systems and support for integrated electrical power distribution

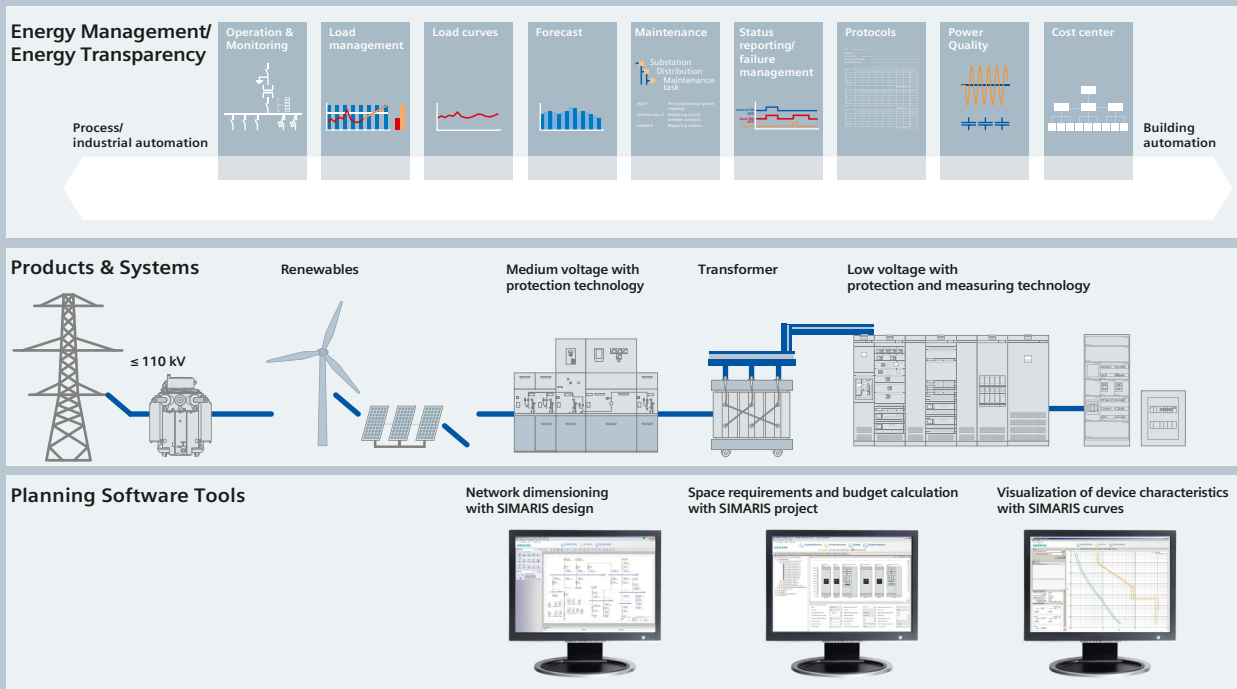

The power supply system acts like a “vital artery”, forming the basis for the reliable and efficient functioning of all electrically operated building installations. Electrical power distribution therefore requires integrated solutions. Our answer: Totally Integrated Power (TIP).

This includes software tools and support for planning and configuration and a complete, optimally aligned product and system portfolio for integrated power distribution from medium-voltage switchgear right to socket outlets.

The power distribution products and systems can be interfaced to building or industrial automation systems (Total Building Solutions or Totally Integrated Automation) via communication-capable circuit breakers and components, allowing the full potential for optimization that an integrated solution offers to be exploited throughout the project cycle – from planning right through to installation and operation.

Get more information:

www.siemens.com/tip
www.siemens.com/simaris
www.siemens.com/specifications

Introduction



- 1/2 Overview
- 1/2 The ongoing development of a well-proven product
- 1/2 ETO – Always the optimum solution (Engineered to Order)
- 1/3 The leading expert in the field of explosion-proof drives
- 1/3 We will be glad to document the proper functioning and quality of your drive!

1/4 **SINAMICS G180**

- 1/4 Overview
- 1/5 Benefits
- 1/5 Application
- 1/5 Design
- 1/5 Platform concept
- 1/5 Function
- 1/5 Power unit
- 1/5 Control section
- 1/5 Operation and settings
- 1/5 Explosion protection
- 1/5 Safe Torque Off
- 1/6 Communication
- 1/6 Drive behavior
- 1/6 General
- 1/6 Technical data
- 1/6 Overview of data for SINAMICS G180 compact units, cabinet systems and cabinet units
- 1/6 More information
- 1/6 Quality management to DIN EN ISO 9001

SINAMICS G180

Introduction

1

Overview

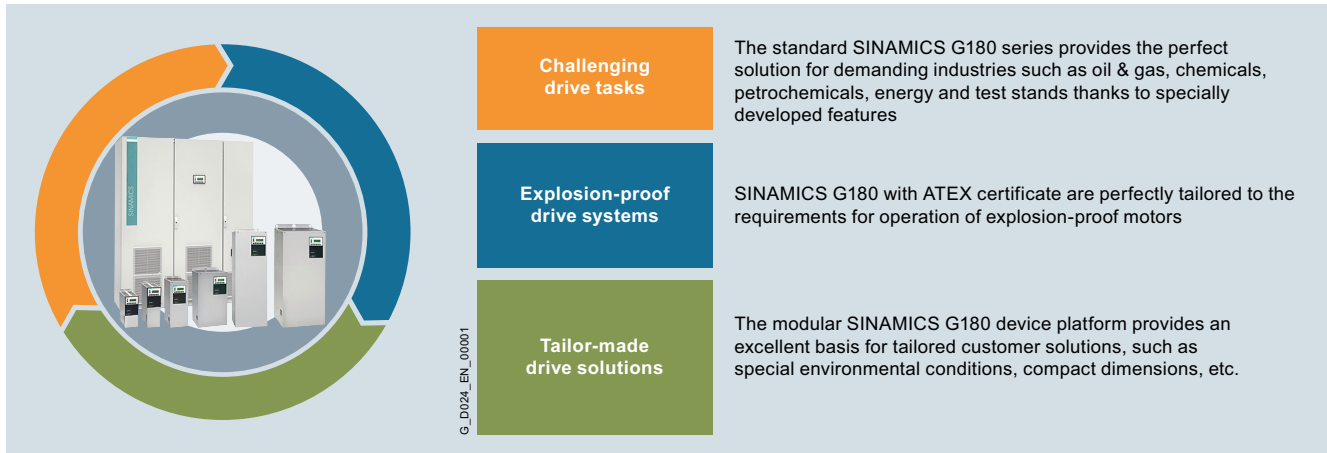

The ongoing development of a well-proven product

SINAMICS G180 leverages the experience that the Siemens Ruhstorf manufacturing location has accumulated and proven in over four decades of successful use in extremely demanding industries, for example, in the chemical and oil & gas industries.

For use in hazardous zones, SINAMICS G180 is the perfect drive solution, since a large number of industry-specific features are already integrated as standard in the system.

SINAMICS G180 is capable of fulfilling all requirements, from relatively straightforward applications such as pumps and fans, up to sophisticated drive solutions with outputs ranging from 2.2 to 6700 kW for applications such as centrifuges, presses, extruders or compressors.

ETO – Always the optimum solution (Engineered to Order)

In addition to a broad range of converters for single and group drives with standardized options, we can also supply complete drive systems which are individually customized such as, for example, converter transformer, converter and motor – "Engineered to Order (ETO)".

How does the customer benefit? We can create the required drive system quickly and systematically.

"Engineered to Order" includes all the essential components – motor, converter transformer, accessories for adapting the drive to challenging line supply conditions, degrees of protection up to IP55 or extremely long motor cables, as well as a variety of control and communication concepts – from the planning stage to production and documentation, commissioning and servicing – including and particularly for hazardous zones. Tailor-made solutions for the customer's application are worked out as early as the offer stage. All aspects of the drive are taken into account from the very beginning – from the coupling to the motor, the cabling, the converter, the line system conditions at the installation site and the supervisory control system interface.

ETO also provides documentation which is tailored to your requirements, including a description of the interfaces to the supervisory control system or other external systems.

Taking a structured and efficient approach, we apply our many years of motor manufacturing expertise to the design and adaptation of the SINAMICS G180 because product developments in the motor and converter fields are closely coordinated.

Preassignment of the SINAMICS G180 parameters at the factory speeds up commissioning significantly.

In addition to customized system designs, we offer a range of converter solutions based on standardized accessories packages which are now widely used in a very broad spectrum of industries.

Overview

The leading expert in the field of explosion-proof drives

The Siemens manufacturing Ruhstorf has been a leading supplier of explosion-proof drives since 1960 and has since built an excellent reputation around the world as a recognized expert in the field.

We are always 100 % reliable when it comes to designing the key explosion-proof features of drive systems. We examine every single element of the entire drive package.

Our frequency converters are specially designed for operation with explosion-proof motors and are certified for EEx n, EEx e and EEx d types of protection according to ATEX.

The motors are protected thermally by temperature sensors which are evaluated directly in the converter. The PTC thermistor input (with ATEX certification) on the converter makes any further accessories such as main contactor or PTC relay completely unnecessary.



We don't leave our customers on their own to deal with the "Ex" problem!

We can answer all your questions such as

- What is the correct converter clock frequency?
- What is the maximum permissible terminal voltage at the motor terminal box?
- How high are the voltage peaks at the motor when long motor cables are used?
- What winding insulation does the motor need?
- Fed-in winding or preformed coil?
- Should the motor be protected by PTCs and/or Pt100s?
- etc.

We will be glad to document the proper functioning and quality of your drive!

We use a state-of-the-art test bay to verify and confirm the proper functioning and quality of each individual converter – and do this gladly in the presence of the customer by way of an acceptance test. In addition to visual inspections and function tests, we can also test and document the output and efficiency of the overall drive and its line supply behavior. Our test stand is equipped with loading devices and measuring instruments for outputs of up to around 6700 kW.

Our quality management is certified in accordance with DIN ISO 9001 and is therefore subject to regular stringent quality audits by independent test institutes.

SINAMICS G180

Introduction

SINAMICS G180

1

Overview



SINAMICS G180 benefits from the many years of expertise acquired by the Siemens manufacturing in Ruhstorf the manufacture of motors and converters to the extent that the frequency converters are always systematically developed to take into account the requirements of the drive system as a whole.

SINAMICS G180 converters can be supplied for standard voltages 400, 500 and 690 V in the output range up to 6.6 MW. They are available as a compact unit, a cabinet system or a cabinet unit, with air cooling, for operation with synchronous and induction motors.

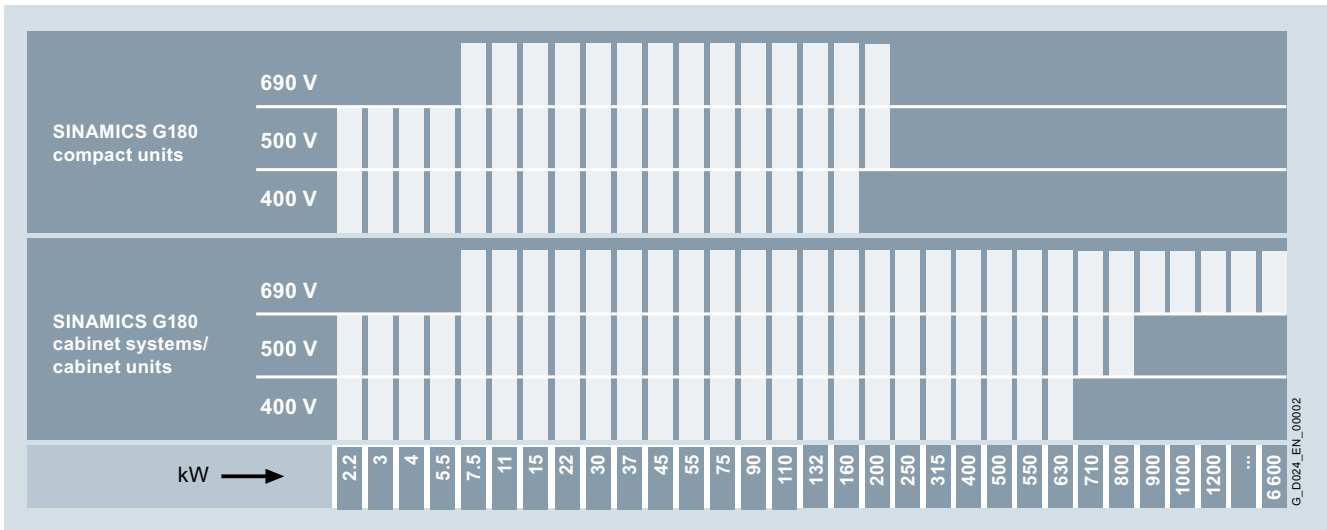

Output ranges of SINAMICS G180 (higher outputs with 400 and 500 V cabinet units available on request)

A wide range of add-on electrical components allow the drive system to be optimized for specific requirements. Configuring is greatly simplified by predefined interfaces and commissioning is speeded up by the preassignment of parameter settings at the factory.

The accuracy of the sensorless vector control makes the converter an ideal partner for many types of drives, such as those used for pumps, fans, centrifuges, presses, extruders or compressors, and an additional actual speed value encoder is therefore superfluous.

Appropriate encoder evaluation units are available for the SINAMICS G180 converters so that they can address applications that require an encoder for plant-specific reasons.

The SINAMICS G180 can be flexibly integrated into any automation concept whether it employs a conventional control or a bus system.

Apart from the standard converter interface (compliant with NAMUR NE37), the following can also be supplied as options to provide communication with the supervisory control system:

- PROFINET
- PROFIBUS DP
- Modbus RTU
- Modbus TCP
- CANopen

Optionally available peripheral boards can be selected to add the following inputs/outputs to the converter:

- Digital and analog inputs and outputs
- 2 PTC thermistor inputs for ATEX-certified motor temperature monitoring for motors in hazardous zones (prewarning/trip)

Benefits

- The converters are exceptionally quiet and compact thanks to state-of-the-art IGBT power semiconductors and an innovative cooling concept.
- The clock frequency is optimized to reduce system losses to a minimum.
- The "random pattern" function significantly reduces motor noise.
- Plant and system availability are increased by being able to quickly and simply replace power components.
- Essential spare parts can be requested at any time for any individual converter by means of the "SparesOnWeb" Internet tool.
- Optimized use of components reduces cabinet dimensions to a minimum.
- Easy integration into automation solutions via analog and digital interfaces. Number of interfaces can also be expanded through installation of an optional peripheral board.
- Data are transmitted over popular bus systems (PROFINET, PROFIBUS DP, Modbus RTU, Modbus TCP or CANopen)
- Fast, easy commissioning and parameterization using interactive menus on an operator panel with illuminated graphic LCD and plain-text display, or PC-supported using the IMS commissioning tool (Inverter Management Software).
- The entire production process is required to meet stringent quality standards and subject to extensive controls, thereby ensuring a high degree of functional reliability during installation, commissioning and operation.

Application

The SINAMICS G180 is especially suited to applications in industries such as the

- chemical industry
- oil and gas industry
- power plant and utilities industries
- plastics industry
- process industry
- primary industry
- test bench systems
- conveyor systems

and for general mechanical engineering applications.

Design

Platform concept

All of the SINAMICS G180 versions are consistently based on an integrated, standardized, common, modular platform concept. Shared hardware and software components, as well as standardized tools for dimensioning, configuring and commissioning tasks ensure a high level of integration between all components.

All devices – from the lowest rating class in compact unit form to the largest version in the form of an air-cooled cabinet unit – have the same features with a virtually identical scope of functions.

All frequency converters in the SINAMICS G180 range operate with the Control Board. All Control Boards utilize the same firmware and all are operated via the Inverter Management Software IMS. Both the IMS and the firmware can be upgraded and downgraded as required to facilitate communication.

Function

Power unit

- Complies with EMC guidelines defined in EN 61800-3 thanks to line filter which is integrated as standard (with grounded supply system)
 - Category C2 for compact units in TN/TT system of the first environment (residential area), category C1 available as an option
 - Category C3 for cabinet units (TN/TT system) of the second environment (industrial area)
 - Category C4 for compact and cabinet units in IT system of the second environment (industrial area)
- SINAMICS G180 converters cause minor line harmonics: Thanks to line reactors integrated in cabinet units and DC reactors integrated in compact units
- Output filter to permit the use of long motor cables for motors with standard insulation
- Insulation monitoring for IT systems integrated in 500/690 V units and ground fault monitoring for TN and TT systems integrated in 400 V units
- Wide range of input voltages
- Lower additional motor noise emissions of typically 3 dB(A) as well as minor losses in converter and motor thanks to optimized pulse pattern and converter clock frequency
- Units can be protected by standard fuses (gL characteristic)
- Standardized user interface on units rated from 2.2 to 6700 kW

Control section

- High level of protection for personnel and plant is provided by protective separation of the safety extra-low voltage in accordance with IEC/EN 61800-5-1 at the analog and digital control inputs and outputs of the power unit.

Operation and settings

- Straightforward to operate and set by means of a menu-assisted, 4-line plaintext display with membrane keyboard on the converter unit or remotely from the control room via an RS485 link at a distance of up to 1000 m
- Extensive range of functions using a Windows-based PC operating program

Explosion protection

- ATEX-certified tripping concept in accordance with Directive 2014/34/EU for the safe operation of motors in hazardous zones 1 and 2, which means that no main contactor is required

Safe Torque Off

Available with options **G04, G05, G08**

- Shutdown mechanism to prevent unexpected starting. Category 0 stop function in accordance with EN 60204-1 (stop by disconnection of power supply to the machine).
- Functional safety in accordance with:
 - SIL 2 as per EN 61508
 - Category 3 to EN ISO 13849-1
 - Performance Level (PL) d to EN ISO 13849-1
- Functional safety in accordance with IEC 61508: SIL 3 is possible in conjunction with options **S01+Y11** or **S02+Y11**.

SINAMICS G180

Introduction

SINAMICS G180

1

Function

Communication

- Communication via conventional terminal strip with freely programmable digital and analog inputs/outputs with
 - parameterizable limit value signals
 - parameterizable timers
 - parameterizable attenuators
 - parameterizable converter behavior when inputs/outputs respond
 - parameterizable logic elements
- Communication and parameterization by means of
 - PC using IMS (Inverter Management Software) via USB interface
 - External operator panel via RS485 link
 - Bus systems such as PROFINET, PROFIBUS DP, Modbus RTU, Modbus TCP or CANopen

Drive behavior

- Closed-loop control of synchronous and induction motors
- Two control modes for induction motors:
 - Space vector control for standard applications (without feedback)
 - Field-oriented closed-loop control for dynamic requirements
- Optimum braking without any supplementary equipment by means of oversaturation control system. With approximately 10 % braking torque at high speed range and up to 50 % at low to medium speed range.

General

- Automatic slip compensation
- Stall protection provided by current limitation control
- Flying restart function for connection to rotating motor
- Automatic adjustment of the overload times
- Parameterizable DC braking for precise deceleration down to zero speed
- Torque control
- Automatic restart (Auto Restart)
- Voltage and current control systems (AC as well as DC with variable frequency)
- Mains supply backup is possible
- Integrated process controller for basic, higher-level closed-loop control tasks
- Optionally available integrated braking chopper for increased braking torque
- Operation of groups of units with interconnected DC links is possible

Technical data

Overview of data for SINAMICS G180 compact units, cabinet systems and cabinet units

Type	Converter
Output range	2.2 to 6700 kW (3 to 7488 hp)
Input voltage	230 to 690 V AC (standard), 50/60 Hz
Pulse number	6-/12-/18-/24-pulse
Type of cooling	Air-cooled
Machine type	Induction motor, synchronous motor

More information

Quality management to DIN EN ISO 9001

SINAMICS G180 converters conform to the most exacting quality requirements. Comprehensive quality assurance measures in all development and production processes ensure a consistently high level of quality.

Of course, our quality management system is certified by an independent authority in accordance with DIN EN ISO 9001.

SINAMICS G180 compact units and SINAMICS G180 cabinet systems

2



2/2 SINAMICS G180 compact units

[2/2 Overview](#)

[2/2 Design](#)

[2/3 Technical data](#)

2/3 Standards for compact units

2/4 General technical data

2/5 400 V, 6-pulse

2/9 500 V, 6-pulse

2/13 690 V, 6-pulse

[2/16 Selection and ordering data](#)

2/16 400 V, 6-pulse

2/16 500 V, 6-pulse

2/17 690 V, 6-pulse

2/18 Article number code

2/18 Number code for converter type

[2/19 Options](#)

2/19 400 V TN/TT system

2/19 500 V IT system

2/19 690 V TN/TT system

2/19 690 V IT system

[2/22 Dimensional drawings](#)

2/22 Frame size K1

2/23 Frame size K2

2/24 Frame size K3

2/25 Frame size K4

2/26 Frame size K5

2/27 Frame size K51

2/28 Frame size K6

2/29 SINAMICS G180 cabinet systems

[2/29 Overview](#)

[2/29 Design](#)

[2/30 Selection and ordering data](#)

2/30 400 V, 6-pulse

2/30 500 V, 6-pulse

2/31 690 V, 6-pulse

2/32 Article number code

2/32 Number code for converter type

[2/33 Options](#)

2/33 400 V TN/TT system

2/33 500 V IT system

2/40 690 V TN/TT system

2/40 690 V IT system

[2/47 Dimensional drawing](#)

2/47 Standard cabinet size SL1 for cabinet systems (option H81)

SINAMICS G180

SINAMICS G180 compact units and SINAMICS G180 cabinet systems

SINAMICS G180 compact units

Overview

The compact version of the SINAMICS G180 is a converter that can be combined very flexibly with the associated system components and integrated into customer-specific control cabinets or directly into machines.

Global use

SINAMICS G180 converter compact units are manufactured in compliance with relevant international standards and regulations, and are therefore suitable for global use (see technical data).



SINAMICS G180 compact unit

SINAMICS G180 converter compact units are available for the following voltages and power ratings:

Overview of voltages and power ratings for SINAMICS G180 compact units

Rated line voltage	Power
400 V 3 AC	2.2 ... 160 kW
500 V 3 AC	2.2 ... 200 kW
690 V 3 AC	7.5 ... 200 kW

Design

- Rugged, compact aluminum enclosure
- IP20 degree of protection, optionally with IP21 protective top cover
- Convenient terminal compartment for EMC-compliant cable connections to NAMUR NE 37 in the device
- Complete touch protection in accordance with Employers' Liability Association regulations (BGV A3)
- DC reactor fitted as standard to reduce harmonics, THD I 5th < 40 %
- dv/dt filter fitted as standard to reduce voltage peaks in the motor
 - Voltage gradient $dv/dt < 1500 \text{ V}/\mu\text{s}$
 - Peak voltages \hat{U}_{LL} (typically) < 1560 V

Technical data

The most important directives and standards are listed below. These are used as basis for the SINAMICS G180 compact units and they must be carefully observed to achieve an EMC-compliant configuration that is safe both functionally and in operation.

Standards for compact units**European directives**

2006/42/EC	Machinery Directive Directive of the European Parliament and Council of May 17, 2006, on machinery and amending Directive 95/16/EC (recast)
2014/35/EU	Low-Voltage Directive Directive of the European Parliament and Council of February 26, 2014 for the harmonization of the laws of the member states relating to the provision of electrical equipment designed for use within certain voltage limits on the market (recast)
2014/30/EU	EMC Directive Directive of the European Parliament and Council of February 26, 2014 for the harmonization of the laws of the member states relating to electromagnetic compatibility (recast)
2011/65/EU	RoHS Directive Directive of the European Parliament and of the Council of 8 June 2011 on the restriction of the use of certain hazardous substances in electrical and electronic equipment (recast)
(EU) 2019/1781	Regulation ecodesign requirements acc. to Ecodesign Directive Commission Regulation of October 1, 2019 on ecodesign requirements for electric motors and variable speed drives pursuant to Directive 2009/125/EC

International and European standards

EN ISO 13849-1	Safety of machinery – Safety-related parts of control systems; Part 1: General design principles (EN ISO 13849-1:2015)
EN 60146-1-1	Semiconductor converters – General requirements and line-commutated converters Part 1-1: Specification of basic requirements (EN 60146-1-1:2010)
EN 60204-1	Electrical equipment of machines, Part 1: General definitions (EN 60204-1:2007)
EN 60529	Degrees of protection provided by enclosures (IP code) (EN 60529:1991/A1:2000/A2:2013)
EN 61140	Protection against electric shock – Common aspects for installation and equipment (EN 61140-1-1:2016)
EN 61508-1	Functional safety of electrical/electronic/programmable electronic safety-related systems, Part 1: General requirements (EN 61508-1:2010)
EN 61800-2	Adjustable speed electrical power drive systems, Part 2: General requirements – Rating specifications for low-voltage adjustable frequency AC power drive systems (EN 61800-2:2015)
EN 61800-3	Adjustable speed electrical power drive systems, Part 3: EMC requirements and specific test methods (EN 61800-3:2004/A1:2012)
EN 61800-5-1	Adjustable-speed electrical power drive systems, Part 5-1: Safety requirements – Electrical, thermal and energy requirements (EN 61800-5-1:2007/A1:2017/A11:2021)
EN 61800-5-2	Adjustable-speed electrical power drive systems, Part 5-2: Safety requirements – Functional safety (EN 61800-5-2:2017)

SINAMICS G180

SINAMICS G180 compact units and SINAMICS G180 cabinet systems

SINAMICS G180 compact units

Technical data

General technical data

Electrical data			
	Line voltages	Type of supply system	Power ranges
	230 ... 400 ... 500 V 3 AC, -15/+10 %	TN/TT system	2.2 ... 160 kW (at 400 V)
	230 ... 500 V 3 AC, -15/+10 %	IT system	2.2 ... 200 kW (at 500 V)
	230 ... 690 V 3 AC, -15/+10 %	TN/TT or IT system	7.5 ... 200 kW (at 690 V)
Line frequency	47 ... 63 Hz		
Output frequency	0 ... 250 Hz		
Voltage rise in motor	Typ. 500 ... 1000 V/μs, but < 1500 V/μs		
Typical line harmonics (<i>I</i>) in % of fundamental mode for the 5/7/11/13/17/19/23/25 harmonics max.	38/18/8/7/5/4/3/2		
Typical line harmonics (<i>I</i>) for converter powers from 22 to 160/200 kW in % of fundamental mode for the 5/7/11/13/17/19/23/25 harmonics max. with LHF filter	1.4/3.6/2.4/1.7/1.0/0.6/0.8/0.4		
Typical line harmonics (<i>I</i>) for converter powers from 2.2 to 15 kW in % of fundamental mode for the 5/7/11/13/17/19/23/25 harmonics max. with LHF filter	4.5/4.7/2.8/1.6/1.2/0.9/0.6/0.5		
Pulse number	6		
Overvoltage category	III to EN 61800-5-1		
Short Circuit Current Rating (SCCR) in conjunction with the specified fuses or circuit breakers	60 kA		
Control method	<ul style="list-style-type: none"> For motors: Field-oriented control (FOC) with sensor and approval for explosion-proof motors as well as vector control (SVC) with/without sensor (speed, process <i>speed</i> (<i>n</i>), torque, hoist¹⁾, line synchronization¹⁾) Motor-independent control of current or voltage (current, process <i>current</i> (<i>I</i>), voltage, process <i>voltage</i> (<i>U</i>)) 		
Fixed speeds	3 fixed speeds + 1 minimum speed, parameterizable		
Skipped speed ranges	2, parameterizable		
Setpoint resolution	13 bits digital with <i>n/f</i> setpoint, 12 bits digital with <i>U/I</i> torque setpoint, 9 bits + sign analog		
Braking operation	The oversaturation control system makes it possible to generate a braking torque of up to 50 % at low to mid-range speeds, and of up to 10 % at high speeds. If a higher braking torque is required, an optionally available braking module with appropriate braking resistor must be installed.		
Mechanical data			
Degree of protection	IP20, optionally IP21 provided by protective top cover (aluminum, unpainted)		
Protection class	I acc. to EN 61800-5-1		
Touch protection	EN 50274 / BGV A3		
Type of cooling	Forced air cooling AF to EN 60146		
Paint finish	RAL 9023 (R-Pearl Dark Grey)		
Cable entry	From below		
Ambient conditions ²⁾			
	Storage ³⁾	Transport ³⁾	Operation
Ambient temperature	-25 ... +55 °C	-25 ... +70 °C down to -40 °C for 24h Class 2K3 acc. to EN 60721-3-2: 1997	Air: 0 ... 40 °C/ –
Relative humidity (condensation not permissible)	5 ... 95 % Class 1K3 acc. to EN 60721-3-1: 1997	5 ... 95 % Class 2K3 acc. to EN 60721-3-2: 1997	5 ... 95 % Class 3K3 acc. to EN 60721-3-3: 2002
Environmental class/harmful chemical substances	Class 1C2 acc. to EN 60721-3-1: 1997	Class 2C2 acc. to EN 60721-3-2: 1997	Class 3C2 acc. to EN 60721-3-3: 2002
Organic/biological influences	Class 1B1 acc. to EN 60721-3-1: 1997	Class 2B1 acc. to EN 60721-3-2: 1997	Class 3B1 acc. to EN 60721-3-3: 2002
Pollution degree	2 acc. to EN 61800-5-1		
Installation altitude	Up to 1000 m above sea level without derating, > 1000 m see derating table (in chapter Configuring instructions)		
Mechanical stability ²⁾			
	Storage ³⁾	Transport ³⁾	Operation
Vibratory load	1.5 mm at 5 ... 9 Hz	3.1 mm at 5 ... 9 Hz	0.075 mm at 10 ... 58 Hz
• Deflection	5 m/s ² at >9 ... 200 Hz	10 m/s ² at >9 ... 200 Hz	10 m/s ² at >58 ... 200 Hz
• Acceleration	Class 1M2 acc. to EN 60721-3-1: 1997	Class 2M2 acc. to EN 60721-3-2: 1997	–
Shock load	40 m/s ² at 22 ms	100 m/s ² at 11 ms	100 m/s ² at 11 ms
• Acceleration	Class 1M2 acc. to EN 60721-3-1: 1997	Class 2M2 acc. to EN 60721-3-2: 1997	Class 3M4 acc. to EN 60721-3-3: 2002
Compliance with standards			
CE Label	Acc. to EMC Directive 2014/30/EU, Low-Voltage Directive 2014/35/EU and Ecodesign requirements of the EU Directive 2019/1781		
Radio interference suppression	Complies with EMC guidelines defined in EN 61800-3 thanks to line filter which is integrated as standard (with grounded supply system): <ul style="list-style-type: none"> • Category C2 for compact units in TN/TT system of the first environment (residential area), category C1 available as an option • Category C4 for compact units in IT system of the second environment (industrial area) 		

Deviations from the specified classes are underlined.

¹⁾ On request

³⁾ In transport packaging

²⁾ Higher standards on request

Technical data

400 V, 6-pulse

Line voltage, supply system type		230 ... 500 V 3 AC, TT/TN				
SINAMICS G180 compact units		6SE0100-1AC15-5AA7	6SE0100-1AC17-0AA7	6SE0100-1AC21-0AA7	6SE0100-1AC21-3AA7	6SE0100-1AC21-8AA7
Converter type		2T2A-07400-002	2T2A-07400-003	2T2A-07400-004	2T2A-07400-005	2T2A-07400-007
Electrical data at motor end						
Type rating ¹⁾						
• at 50 Hz 400 V	kW	2.2	3	4	5.5	7.5
• at 60 Hz 460 V	hp	3	5	6	9	12
Output voltage ²⁾		V	0 ... 0.98 × V _{line}	0 ... 0.98 × V _{line}	0 ... 0.98 × V _{line}	0 ... 0.98 × V _{line}
Output current						
• Continuous current	A	5.5	7	9.5	13	18
• Short-time current (60 s every 10 minutes) max.	A	6.5	8	11	15	20
Output power		kVA	3.8	4.8	6.6	12.5
Output frequency, max.		Hz	250	250	250	250
Rated clock cycle adjustable from		kHz	4.5	4.5	4.5	4.5
	kHz	3 ... 7.5	3 ... 7.5	3 ... 7.5	3 ... 7.5	3 ... 7.5
Power loss ³⁾		kW	0.13	0.16	0.2	0.33
Rated efficiency		%	95.2	95.8	95.9	96.2
Electrical data at line end						
Connected load		kVA	3.7	4.5	6.2	12
Rated input voltage		V	400	400	400	400
Input current						
• Continuous line current	A	5.3	6.5	8.9	12.2	17.3
• Short-time line current (60 s) max.	A	6.3	7.4	10	14	19
Line fuse (provided by customer)		gL (A)	6 ... 16	10 ... 16	10 ... 16	20 ... 32
λ _{line}			0.927	0.94	0.918	0.937
Cos φ _{line}			1	1	1	1
Radio interference suppression acc. to EN 61800-3			C2 (class A filter)	C2 (class A filter)	C2 (class A filter)	C2 (class A filter)
Mechanical data						
Coolant requirements		m ³ /h	45	45	90	90
Sound pressure level L _{pA} (1 m) at 50/60 Hz		dB	60	60	60	60
Max. cable length between converter and motor with standard insulation						
• on systems ≤ 400 V (shielded)	m	200/350 ⁴⁾	200/350 ⁴⁾	200/350 ⁴⁾	200/350 ⁴⁾	200/350 ⁴⁾
• on systems > 400 V (shielded)	m	150/300 ⁴⁾	150/300 ⁴⁾	150/300 ⁴⁾	150/300 ⁴⁾	150/300 ⁴⁾
Line/load connection						
L1, L2, L3/U2, V2, W2						
For connection cross-sections, see "Cable cross-sections and connections" in section "Configuring instructions"						
Dimensions						
• Width	mm	165	165	165	165	165
• Height (without mounting brackets)	mm	410	410	410	410	510
• Depth	mm	320	320	320	320	320
Weight, approx.		kg	11.5	11.5	11.5	16.5
Frame size			K1	K1	K1	K2

¹⁾ Rated power of a typical 2- to 6-pole standard motor.

²⁾ Typical output voltage dependent on filter and unit type.

³⁾ Maximum power loss with continuous current.

⁴⁾ Value is applicable with option L10 (strengthened dv/dt filter; strengthened filter is integrated in unit).

SINAMICS G180

SINAMICS G180 compact units and SINAMICS G180 cabinet systems

SINAMICS G180 compact units

Technical data

400 V, 6-pulse (continued)

Line voltage, supply system type		230 ... 500 V 3 AC, TT/TN				
SINAMICS G180 compact units		6SE0100-1AC22-5AA7	6SE0100-1AC23-7AA7	6SE0100-1AC24-8AA7	6SE0100-1AC25-8AA7	6SE0100-1AC27-8AA7
Converter type		2T2A-07400-011	2T2A-07400-015	2T2A-07400-022	2T2A-07400-030	2T2A-07400-037
Electrical data at motor end						
Type rating¹⁾						
• at 50 Hz 400 V	kW	11	15	22	30	37
• at 60 Hz 460 V	hp	17	23	34	46	57
Output voltage²⁾		V	0 ... 0.98 × V _{line}	0 ... 0.98 × V _{line}	0 ... 0.98 × V _{line}	0 ... 0.98 × V _{line}
Output current						
• Continuous current	A	24.5	37	48	58	78
• Short-time current (60 s every 10 minutes) max.	A	27	44	54	63	88
Output power	kVA	17	25.6	33.3	40.2	54
Output frequency, max.	Hz	250	250	250	250	250
Rated clock cycle	kHz	4.5	4.5	4.5	4.5	3
adjustable from	kHz	3 ... 7.5	3 ... 7.5	3 ... 7.5	3 ... 7.5	2 ... 5
Power loss³⁾	kW	0.47	0.6	0.84	1.1	1.35
Rated efficiency	%	96.3	96.5	96.6	96.7	96.7
Electrical data at line end						
Connected load	kVA	15.7	24.3	31.8	39.1	52.2
Rated input voltage	V	400	400	400	400	400
Input current						
• Continuous line current	A	22.7	35.1	45.9	56.5	75.3
• Short-time line current (60 s) max.	A	25	42	52	61	85
Line fuse (provided by customer)	gL (A)	25 ... 32	40 ... 80	50 ... 80	63 ... 80	80 ... 100
λ_{line}		0.932	0.932	0.932	0.924	0.932
cos ϕ_{line}		1	1	1	1	1
Radio interference suppression acc. to EN 61800-3		C2 (class A filter)	C2 (class A filter)	C2 (class A filter)	C2 (class A filter)	C2 (class A filter)
Mechanical data						
Coolant requirements	m ³ /h	130	280	280	280	750
Sound pressure level L_{pA} (1 m) at 50/60 Hz	dB	60	60	60	60	62
Max. cable length between converter and motor with standard insulation						
• on systems ≤ 400 V (shielded)	m	200/350 ⁴⁾	200/350 ⁴⁾	200/350 ⁴⁾	200/350 ⁴⁾	200/350 ⁴⁾
• on systems > 400 V (shielded)	m	150/300 ⁴⁾	150/300 ⁴⁾	150/300 ⁴⁾	150/300 ⁴⁾	150/300 ⁴⁾
Line/load connection L1, L2, L3/U2, V2, W2 For connection cross-sections, see "Cable cross-sections and connections" in section "Configuring instructions"						
Dimensions						
• Width	mm	165	225	225	225	350
• Height (without mounting brackets)	mm	510	610	610	610	710
• Depth	mm	320	320	320	320	320
Weight, approx.	kg	16.5	30	31	31	51
Frame size		K2	K3	K3	K3	K4

¹⁾ Rated power of a typical 2- to 6-pole standard motor.

²⁾ Typical output voltage dependent on filter and unit type.

³⁾ Maximum power loss with continuous current.

⁴⁾ Value is applicable with option L10 (strengthened dv/dt filter; strengthened filter is integrated in unit).

Technical data

400 V, 6-pulse (continued)

Line voltage, supply system type		230 ... 500 V 3 AC, TT/TN				
SINAMICS G180 compact units		6SE0100-1AC28-8AA7	6SE0100-1AC31-1AA7	6SE0100-1AC31-5AA7	6SE0100-1AC31-8AA7	6SE0100-1AC32-1AA7
Converter type		2T2A-07400-045	2T2A-07400-055	2T2A-07400-075	2T2A-07400-090	2T2A-07400-110
Electrical data at motor end						
Type rating¹⁾						
• at 50 Hz 400 V	kW	45	55	75	90	110
• at 60 Hz 460 V	hp	69	85	116	139	170
Output voltage²⁾	V	0 ... 0.98 × V _{line}				
Output current						
• Continuous current	A	88	110	145	175	205
• Short-time current (60 s every 10 minutes) max.	A	110	126	165	204	240
Output power	kVA	61	76.2	100	121	142
Output frequency, max.	Hz	250	250	250	250	250
Rated clock cycle	kHz	3	3	3	3	3
adjustable from	kHz	2 ... 5	2 ... 5	2 ... 5	2 ... 5	2 ... 5
Power loss³⁾	kW	1.59	1.86	2.37	2.83	3.33
Rated efficiency	%	96.8	96.9	97.1	97.1	97.2
Electrical data at line end						
Connected load	kVA	57.3	74.8	97.7	119	134
Rated input voltage	V	400	400	400	400	400
Input current						
• Continuous line current	A	82.7	108	141	172	194
• Short-time line current (60 s) max.	A	103	124	160	200	227
Line fuse (provided by customer)	gL (A)	100	125	160	200	200 ... 250
λ_{line}		0.924	0.929	0.929	0.924	0.924
Cos φ_{line}		1	1	1	1	1
Radio interference suppression acc. to EN 61800-3		C2 (class A filter)	C2 (class A filter)	C2 (class A filter)	C2 (class A filter)	C2 (class A filter)
Mechanical data						
Coolant requirements	m ³ /h	750	750	1050	1050	1050
Sound pressure level L_{pA} (1 m) at 50/60 Hz	dB	62	62	64	64	64
Max. cable length between converter and motor with standard insulation						
• on systems ≤ 400 V (shielded)	m	200/350 ⁴⁾	200/350 ⁴⁾	200/350 ⁴⁾	200/350 ⁴⁾	200/350 ⁴⁾
• on systems > 400 V (shielded)	m	150/300 ⁴⁾	150/300 ⁴⁾	150/300 ⁴⁾	150/300 ⁴⁾	150/300 ⁴⁾
Line/load connection						
L1, L2, L3/U2, V2, W2						
For connection cross-sections, see "Cable cross-sections and connections" in section "Configuring instructions"						
Dimensions						
• Width	mm	350	350	350	350	350
• Height (without mounting brackets)	mm	710	710	1060	1060	1060
• Depth	mm	320	320	320	320	320
Weight, approx.	kg	53	55	90	94	96
Frame size		K4	K4	K5	K5	K5

1) Rated power of a typical 2- to 6-pole standard motor.

2) Typical output voltage dependent on filter and unit type.

3) Maximum power loss with continuous current.

4) Value is applicable with option L10 (strengthened dv/dt filter; strengthened filter is integrated in unit).

SINAMICS G180

SINAMICS G180 compact units and SINAMICS G180 cabinet systems

SINAMICS G180 compact units

Technical data

400 V, 6-pulse (continued)

Line voltage, supply system type	230 ... 500 V 3 AC, TT/TN		
SINAMICS G180 compact units	6SE0100-1AC32-5AA7 6SE0100-1AC33-0AA7		
Converter type	2T2A-07400-132 2T2A-07400-160		
Electrical data at motor end			
Type rating¹⁾			
• at 50 Hz 400 V	kW	132	160
• at 60 Hz 460 V	hp	204	247
Output voltage²⁾	V	0 ... 0.98 × V _{line}	0 ... 0.98 × V _{line}
Output current			
• Continuous current	A	245	295
• Short-time current (60 s every 10 minutes) max.	A	300	360
Output power	kVA	170	204
Output frequency, max.	Hz	250	250
Rated clock cycle	kHz	3	3
adjustable from	kHz	2 ... 5	2 ... 5
Power loss³⁾	kW	3.84	4.65
Rated efficiency	%	97.3	97.3
Electrical data at line end			
Connected load	kVA	161	197
Rated input voltage	V	400	400
Input current			
• Continuous line current	A	232	284
• Short-time line current (60 s) max.	A	284	347
Line fuse (provided by customer)	gL (A)	250 ... 315	315 ... 400
λ_{line}		0.924	0.924
Cos φ_{line}		1	1
Radio interference suppression acc. to EN 61800-3		C2 (class A filter)	C2 (class A filter)
Mechanical data			
Coolant requirements	m ³ /h	1600	1600
Sound pressure level L_{pA}			
(1 m) at 50/60 Hz	dB	66	66
Max. cable length between converter and motor with standard insulation			
• on systems ≤ 400 V (shielded)	m	200/350 ⁴⁾	200/350 ⁴⁾
• on systems > 400 V (shielded)	m	150/300 ⁴⁾	150/300 ⁴⁾
Line/load connection			
L1, L2, L3/U2, V2, W2			
For connection cross-sections, see "Cable cross-sections and connections" in section "Configuring instructions"			
Dimensions			
• Width	mm	500	500
• Height (without mounting brackets)	mm	1060	1060
• Depth	mm	320	320
Weight, approx.	kg	160	170
Frame size		K6	K6

¹⁾ Rated power of a typical 2- to 6-pole standard motor.

²⁾ Typical output voltage dependent on filter and unit type.

³⁾ Maximum power loss with continuous current.

⁴⁾ Value is applicable with option L10 (strengthened dv/dt filter; strengthened filter is integrated in unit).

Technical data

500 V, 6-pulse

Line voltage, supply system type		230 ... 500 V 3 AC, IT				
SINAMICS G180 compact units		6SE0100-1AD14-5AA7	6SE0100-1AD15-5AA7	6SE0100-1AD17-0AA7	6SE0100-1AD21-0AA7	6SE0100-1AD21-3AA7
Converter type		2T2A-07500-002	2T2A-07500-003	2T2A-07500-004	2T2A-07500-005	2T2A-07500-007
Electrical data at motor end						
Type rating ¹⁾						
• at 50 Hz 500 V	kW	2.2	3	4	5.5	7.5
• at 60 Hz 460 V	hp	3	4	5	7	9
Output voltage ²⁾		V	0 ... 0.98 × V _{line}	0 ... 0.98 × V _{line}	0 ... 0.98 × V _{line}	0 ... 0.98 × V _{line}
Output current						
• Continuous current	A	4.5	5.5	7	9.5	13
• Short-time current (60 s every 10 minutes) max.	A	5	6.5	8	11	15
Output power		kVA	3.9	4.8	6.1	11.3
Output frequency, max.		Hz	250	250	250	250
Rated clock cycle		kHz	4.5	4.5	4.5	4.5
adjustable from	kHz	3 ... 7.5	3 ... 7.5	3 ... 7.5	3 ... 7.5	3 ... 7.5
Power loss ³⁾		kW	0.12	0.16	0.2	0.34
Rated efficiency		%	95.6	95.7	95.9	96.1
Electrical data at line end						
Connected load		kVA	3.7	4.6	6.4	12.1
Rated input voltage		V	500	500	500	500
Input current						
• Continuous line current	A	4.4	5.2	6.5	9.3	12.5
• Short-time line current (60 s) max.	A	4.9	6.1	7.4	11	14
Line fuse (provided by customer)		gL (A)	4 ... 16	6 ... 16	10 ... 16	16
λ _{line}			0.902	0.912	0.932	0.908
Cos φ _{line}			1	1	1	1
Radio interference suppression acc. to EN 61800-3			C4	C4	C4	C4
Mechanical data						
Coolant requirements		m ³ /h	45	45	45	90
Sound pressure level L _{pA} (1 m) at 50/60 Hz		dB	60	60	60	60
Max. cable length between converter and motor with standard insulation						
• (shielded)	m	300 ⁴⁾	300 ⁴⁾	300 ⁴⁾	300 ⁴⁾	300 ⁴⁾
Line/load connection						
L1, L2, L3/U2, V2, W2						
For connection cross-sections, see "Cable cross-sections and connections" in section "Configuring instructions"						
Dimensions						
• Width	mm	165	165	165	165	165
• Height (without mounting brackets)	mm	410	410	410	410	410
• Depth	mm	320	320	320	320	320
Weight, approx.		kg	11.5	11.5	11.5	11.5
Frame size			K1	K1	K1	K1

¹⁾ Rated power of a typical 2- to 6-pole standard motor.

²⁾ Typical output voltage dependent on filter and unit type.

³⁾ Maximum power loss with continuous current.

⁴⁾ Option L10 included (strengthened dv/dt filter; strengthened filter is integrated in unit).

SINAMICS G180

SINAMICS G180 compact units and SINAMICS G180 cabinet systems

SINAMICS G180 compact units

Technical data

500 V, 6-pulse (continued)

Line voltage, supply system type		230 ... 500 V 3 AC, IT				
SINAMICS G180 compact units		6SE0100-1AD21-8AA7	6SE0100-1AD22-5AA7	6SE0100-1AD23-7AA7	6SE0100-1AD24-8AA7	6SE0100-1AD25-8AA7
Converter type		2T2A-07500-011	2T2A-07500-015	2T2A-07500-022	2T2A-07500-030	2T2A-07500-037
Electrical data at motor end						
Type rating ¹⁾						
• at 50 Hz 500 V	kW	11	15	22	30	37
• at 60 Hz 460 V	hp	17	23	34	46	57
Output voltage ²⁾		V	0 ... 0.98 × V _{line}	0 ... 0.98 × V _{line}	0 ... 0.98 × V _{line}	0 ... 0.98 × V _{line}
Output current						
• Continuous current	A	18	24.5	37	48	58
• Short-time current (60 s every 10 minutes) max.	A	20	27	44	54	63
Output power		kVA	15.6	21.2	32	41.6
Output frequency, max.		Hz	250	250	250	250
Rated clock cycle		kHz	4.5	4.5	4.5	4.5
adjustable from	kHz	3 ... 7.5	3 ... 7.5	3 ... 7.5	3 ... 7.5	3 ... 7.5
Power loss ³⁾		kW	0.48	0.63	0.89	1.17
Rated efficiency		%	96.2	96.3	96.4	96.5
Electrical data at line end						
Connected load		kVA	16	24.4	32	39.2
Rated input voltage		V	500	500	500	500
Input current						
• Continuous line current	A	17.4	23.4	35.8	46.8	57.1
• Short-time line current (60 s) max.	A	19	26	43	53	62
Line fuse (provided by customer)		gL (A)	20 ... 32	25 ... 32	40 ... 80	50 ... 80
λ _{line}			0.902	0.924	0.918	0.924
Cos φ _{line}			1	1	1	1
Radio interference suppression acc. to EN 61800-3			C4	C4	C4	C4
Mechanical data						
Coolant requirements		m ³ /h	90	130	280	280
Sound pressure level L _{pA} (1 m) at 50/60 Hz		dB	60	60	60	62
Max. cable length between converter and motor with standard insulation						
• (shielded)	m	300 ⁴⁾	300 ⁴⁾	300 ⁴⁾	300 ⁴⁾	300 ⁴⁾
Line/load connection						
L1, L2, L3/U2, V2, W2						
For connection cross-sections, see "Cable cross-sections and connections" in section "Configuring instructions"						
Dimensions						
• Width	mm	165	165	225	225	225
• Height (without mounting brackets)	mm	510	510	610	610	610
• Depth	mm	320	320	320	320	320
Weight, approx.		kg	16.5	17.5	30	32
Frame size			K2	K2	K3	K3

¹⁾ Rated power of a typical 2- to 6-pole standard motor.

²⁾ Typical output voltage dependent on filter and unit type.

³⁾ Maximum power loss with continuous current.

⁴⁾ Option L10 included (strengthened dv/dt filter; strengthened filter is integrated in unit).

SINAMICS G180 compact units and SINAMICS G180 cabinet systems

SINAMICS G180 compact units

Technical data

500 V, 6-pulse (continued)

Line voltage, supply system type		230 ... 500 V 3 AC, IT				
SINAMICS G180 compact units		6SE0100-1AD27-8AA7	6SE0100-1AD28-8AA7	6SE0100-1AD31-1AA7	6SE0100-1AD31-5AA7	6SE0100-1AD31-8AA7
Converter type		2T2A-07500-045	2T2A-07500-055	2T2A-07500-075	2T2A-07500-090	2T2A-07500-110
Electrical data at motor end						
Type rating ¹⁾						
• at 50 Hz 500 V	kW	45	55	75	90	110
• at 60 Hz 460 V	hp	56	68	93	111	136
Output voltage ²⁾		V	0 ... 0.98 × V _{line}	0 ... 0.98 × V _{line}	0 ... 0.98 × V _{line}	0 ... 0.98 × V _{line}
Output current						
• Continuous current	A	78	88	110	145	175
• Short-time current (60 s every 10 minutes) max.	A	88	110	126	165	204
Output power		kVA	67.5	76.2	95.3	126
Output frequency, max.		Hz	250	250	250	250
Rated clock cycle		kHz	3	3	3	3
adjustable from	kHz	2 ... 5	2 ... 5	2 ... 5	20 ... 5	2 ... 5
Power loss ³⁾		kW	1.59	1.8	2.37	2.83
Rated efficiency		%	96.8	97.0	97.1	97.2
Electrical data at line end						
Connected load		kVA	57.5	74.8	98.4	119
Rated input voltage		V	500	500	500	500
Input current						
• Continuous line current	A	73.7	87.6	109	143	170
• Short-time line current (60 s) max.	A	83	110	125	163	198
Line fuse (provided by customer)		gL (A)	80 ... 100	100	125	160
λ _{line}			0.918	0.912	0.918	0.918
Cos φ _{line}			1	1	1	1
Radio interference suppression acc. to EN 61800-3			C4	C4	C4	C4
Mechanical data						
Coolant requirements		m ³ /h	750	750	750	1050
Sound pressure level L _{pA} (1 m) at 50/60 Hz		dB	62	62	64	64
Max. cable length between converter and motor with standard insulation						
• (shielded)	m	300 ⁴⁾	300 ⁴⁾	300 ⁴⁾	300 ⁴⁾	300 ⁴⁾
Line/load connection						
L1, L2, L3/U2, V2, W2						
For connection cross-sections, see "Cable cross-sections and connections" in section "Configuring instructions"						
Dimensions						
• Width	mm	350	350	350	350	350
• Height (without mounting brackets)	mm	710	710	710	1060	1060
• Depth	mm	320	320	320	320	320
Weight, approx.		kg	51	53	55	90
Frame size			K4	K4	K4	K5

¹⁾ Rated power of a typical 2- to 6-pole standard motor.

²⁾ Typical output voltage dependent on filter and unit type.

³⁾ Maximum power loss with continuous current.

⁴⁾ Option L10 included (strengthened dv/dt filter; strengthened filter is integrated in unit).

SINAMICS G180

SINAMICS G180 compact units and SINAMICS G180 cabinet systems

SINAMICS G180 compact units

Technical data

500 V, 6-pulse (continued)

Line voltage, supply system type	230 ... 500 V 3 AC, IT			
SINAMICS G180 compact units	6SE0100-1AD32-1AA7		6SE0100-1AD32-5AA7	
Converter type	2T2A-07500-132		2T2A-07500-160	
			6SE0100-1AD33-0AA7	
			2T2A-07500-200	
Electrical data at motor end				
Type rating¹⁾				
• at 50 Hz 500 V	kW	132	160	200
• at 60 Hz 460 V	hp	163	197	247
Output voltage²⁾	V	0 ... 0.98 × V _{line}		
Output current				
• Continuous current	A	205	245	295
• Short-time current (60 s every 10 minutes) max.	A	240	300	360
Output power	kVA	178	212	256
Output frequency, max.	Hz	250	250	250
Rated clock cycle	kHz	3	3	3
adjustable from	kHz	2 ... 5	2 ... 5	2 ... 5
Power loss³⁾	kW	3.84	4.48	5.6
Rated efficiency	%	97.3	97.4	97.4
Electrical data at line end				
Connected load	kVA	161	197	3.8
Rated input voltage	V	500	500	500
Input current				
• Continuous line current	A	196	237	286
• Short-time line current (60 s) max.	A	230	290	349
Line fuse (provided by customer)	gL (A)	200 ... 250	250 ... 315	315 ... 400
λ_{line}		0.912	0.912	0.912
Cos φ_{line}		1	1	1
Radio interference suppression acc. to EN 61800-3		C4	C4	C4
Mechanical data				
Coolant requirements	m ³ /h	1050	1600	1600
Sound pressure level L_{pA}				
(1 m) at 50/60 Hz	dB	66	66	60
Max. cable length between converter and motor with standard insulation				
• (shielded)	m	300 ⁴⁾	300 ⁴⁾	300 ⁴⁾
Line/load connection				
L1, L2, L3/U2, V2, W2				
For connection cross-sections, see "Cable cross-sections and connections" in section "Configuring instructions"				
Dimensions				
• Width	mm	350	500	500
• Height (without mounting brackets)	mm	1060	1060	1060
• Depth	mm	320	320	320
Weight, approx.	kg	96	170	180
Frame size		K5	K6	K6

¹⁾ Rated power of a typical 2- to 6-pole standard motor.

²⁾ Typical output voltage dependent on filter and unit type.

³⁾ Maximum power loss with continuous current.

⁴⁾ Option L10 included (strengthened dv/dt filter; strengthened filter is integrated in unit).

Technical data

690 V, 6-pulse

Line voltage, supply system type		230 ... 690 V 3 AC, TT/TN or IT				
SINAMICS G180 compact units		6SE0100-1A21-0AA7	6SE0100-1A21-3AA7	6SE0100-1A21-8AA7	6SE0100-1A22-5AA7	6SE0100-1A23-4AA7
Converter type		2T2A-07600-007	2T2A-07600-011	2T2A-07600-015	2T2A-07600-022	2T2A-07600-030
Electrical data at motor end						
Type rating¹⁾						
• at 50 Hz 690 V	kW	7.5	11	15	22	30
• at 60 Hz 575 V	hp	8	12	17	25	34
Output voltage²⁾		V	0 ... 0.98 × V _{line}	0 ... 0.98 × V _{line}	0 ... 0.98 × V _{line}	0 ... 0.98 × V _{line}
Output current						
• Continuous current	A	9.5	13	18	27	36
• Short-time current (60 s every 10 minutes) max.	A	11	16	21	33	45
Output power		kVA	11.4	15.5	21.5	32.3
Output frequency, max.		Hz	250	250	250	250
Rated clock cycle		kHz	3	3	3	3
adjustable from		kHz	2 ... 5	2 ... 5	2 ... 5	2 ... 5
Power loss³⁾		kW	0.29	0.4	0.55	0.74
Rated efficiency		%	96.7	96.8	96.8	97.0
Electrical data at line end						
Connected load		kVA	10.5	14.1	20.1	30.2
Rated input voltage		V	690	690	690	690
Input current						
• Continuous line current	A	8.8	11.8	16.8	25.3	37.3
• Short-time line current (60 s) max.	A	10	14	20	31	47
Line fuse (provided by customer)		gL (A)	10 ... 32	16 ... 32	20 ... 32	32
λ_{line}			0.94	0.948	0.94	0.948
Cos φ_{line}			1	1	1	1
Radio interference suppression acc. to EN 61800-3⁴⁾			C2 (class A filter)	C2 (class A filter)	C2 (class A filter)	C2 (class A filter)
Mechanical data						
Coolant requirements		m ³ /h	90	90	130	130
Sound pressure level L_{pA}						
(1 m) at 50/60 Hz		dB	60	60	60	60
Max. cable length between converter and motor with standard insulation						
• (shielded)		m	300 ⁵⁾	300 ⁵⁾	300 ⁵⁾	300 ⁵⁾
Line/load connection						
L1, L2, L3/U2, V2, W2						
For connection cross-sections, see "Cable cross-sections and connections" in section "Configuring instructions"						
Dimensions						
• Width	mm	225	225	225	225	350
• Height (without mounting brackets)	mm	610	610	610	610	710
• Depth	mm	320	320	320	320	320
Weight, approx.		kg	26	26	28	28
Frame size			K3	K3	K3	K4

1) Rated power of a typical 2- to 6-pole standard motor.

2) Typical output voltage dependent on filter and unit type.

3) Maximum power loss with continuous current.

4) EMC filter not required for IT system, in which case RI suppression category C4.

5) Value is applicable with option L10 (strengthened dv/dt filter; strengthened filter is integrated in unit).

SINAMICS G180

SINAMICS G180 compact units and SINAMICS G180 cabinet systems

SINAMICS G180 compact units

Technical data

690 V, 6-pulse (continued)

Line voltage, supply system type		230 ... 690 V 3 AC, TT/TN or IT				
SINAMICS G180 compact units		6SE0100-1A■24-2AA7	6SE0100-1A■25-0AA7	6SE0100-1A■25-8AA7	6SE0100-1A■28-0AA7	6SE0100-1A■31-0AA7
Converter type		2T2A-07600-037	2T2A-07600-045	2T2A-07600-055	2T2A-07600-075	2T2A-07600-090
Electrical data at motor end						
Type rating ¹⁾						
• at 50 Hz 690 V	kW	37	45	55	75	90
• at 60 Hz 575 V	hp	41	50	62	84	101
Output voltage ²⁾						
	V	0 ... 0.98 × V _{line}	0 ... 0.98 × V _{line}	0 ... 0.98 × V _{line}	0 ... 0.98 × V _{line}	0 ... 0.98 × V _{line}
Output current						
• Continuous current	A	43	50	60	80	95
• Short-time current (60 s every 10 minutes) max.	A	55	65	75	90	120
Output power						
	kVA	51.4	59.8	71.7	95.6	114
Output frequency, max.						
	Hz	250	250	250	250	250
Rated clock cycle						
	kHz	3	3	3	3	3
adjustable from	kHz	2 ... 5	2 ... 5	2 ... 5	2 ... 5	2 ... 5
Power loss ³⁾						
	kW	1.19	1.44	1.68	2.28	2.63
Rated efficiency						
	%	97.1	97.1	97.2	97.2	97.3
Electrical data at line end						
Connected load						
	kVA	51.3	59.9	72.5	96.7	122
Rated input voltage						
	V	690	690	690	690	690
Input current						
• Continuous line current	A	42.9	50.1	60.7	80.9	102
• Short-time line current (60 s) max.	A	55	65	76	91	129
Line fuse (provided by customer)						
	gL (A)	50 ... 63	63	63 ... 80	100	125
λ _{line}						
		0.898	0.863	0.894	0.896	0.845
Cos φ _{line}						
		1	1	1	1	1
Radio interference suppression acc. to EN 61800-3 ⁴⁾						
		C2 (class A filter)	C2 (class A filter)	C2 (class A filter)	C2 (class A filter)	C2 (class A filter)
Mechanical data						
Coolant requirements						
	m ³ /h	750	750	750	750	1050
Sound pressure level L _{pA}						
(1 m) at 50/60 Hz	dB	60	60	60	60	62
Max. cable length between converter and motor with standard insulation						
• (shielded)	m	300 ⁵⁾	300 ⁵⁾	300 ⁵⁾	300 ⁵⁾	150 (300) ⁶⁾
Line/load connection						
L1, L2, L3/U2, V2, W2						
For connection cross-sections, see "Cable cross-sections and connections" in section "Configuring instructions"						
Dimensions						
• Width	mm	350	350	350	350	350
• Height (without mounting brackets)	mm	710	710	710	710	1060
• Depth	mm	320	320	320	320	320
Weight, approx.						
	kg	55	59	59	59	90
Frame size						
		K4	K4	K4	K4	K5

¹⁾ Rated power of a typical 2- to 6-pole standard motor.

²⁾ Typical output voltage dependent on filter and unit type.

³⁾ Maximum power loss with continuous current.

⁴⁾ EMC filter not required for IT system, in which case RI suppression category C4.

⁵⁾ Value is applicable with option L10 (strengthened dv/dt filter; strengthened filter is integrated in unit).

⁶⁾ Value is applicable with option L10 (strengthened dv/dt filter; strengthened filter is supplied separately with unit).

SINAMICS G180 compact units and SINAMICS G180 cabinet systems

SINAMICS G180 compact units

Technical data

690 V, 6-pulse (continued)

Line voltage, supply system type	230 ... 690 V 3 AC, TT/TN or IT				
SINAMICS G180 compact units	6SE0100-1A31-2AA7	6SE0100-1A31-4AA7	6SE0100-1A31-7AA7	6SE0100-1A32-1AA7	
Converter type	2T2A-07600-110	2T2A-07600-132	2T2A-07600-160	2T2A-07600-200	
Electrical data at motor end					
Type rating¹⁾					
• at 50 Hz 690 V	kW	110	132	160	200
• at 60 Hz 575 V	hp	122	148	179	224
Output voltage²⁾	V	0 ... 0.98 × V _{line}			
Output current					
• Continuous current	A	120	150	175	210
• Short-time current (60 s every 10 minutes) max.	A	140	175	210	255
Output power	kVA	143	179	209	251
Output frequency, max.	Hz	250	250	250	250
Rated clock cycle	kHz	3	3	3	3
adjustable from	kHz	2 ... 5	2 ... 5	2 ... 5	2 ... 5
Power loss³⁾	kW	3.21	3.7	4.48	5.38
Rated efficiency	%	97.3	97.4	97.4	97.5
Electrical data at line end					
Connected load	kVA	142	183	215	265
Rated input voltage	V	690	690	690	690
Input current					
• Continuous line current	A	119	153	180	222
• Short-time line current (60 s) max.	A	139	178	216	270
Line fuse (provided by customer)	gL (A)	125 ... 160	160 ... 200	200 ... 250	250 ... 315
λ_{line}		0.883	0.857	0.862	0.838
cos ϕ_{line}		1	1	1	1
Radio interference suppression acc. to EN 61800-3		C2 (class A filter)	C2 (class A filter)	C2 (class A filter)	C2 (class A filter)
Mechanical data					
Coolant requirements	m ³ /h	1050	1050	1600	1600
Sound pressure level L_{pA} (1 m) at 50/60 Hz	dB	62	62	64	64
Max. cable length between converter and motor with standard insulation					
• (shielded)	m	150/300 ⁴⁾	150/300 ⁴⁾	150/300 ⁴⁾	150/300 ⁴⁾
Line/load connection L1, L2, L3/U2, V2, W2 For connection cross-sections, see "Cable cross-sections and connections" in section "Configuring instructions"					
Dimensions					
• Width	mm	350	350	500	500
• Height (without mounting brackets)	mm	1060	1060	1060	1060
• Depth	mm	320	320	320	320
Weight, approx.	kg	94	96	170	180
Frame size		K5	K5	K6	K6

¹⁾ Rated power of a typical 2- to 6-pole standard motor.

²⁾ Typical output voltage dependent on filter and unit type.

³⁾ Maximum power loss with continuous current.

⁴⁾ Value is applicable with option L10 (strengthened dv/dt filter; strengthened filter is supplied separately with unit).

SINAMICS G180

SINAMICS G180 compact units and SINAMICS G180 cabinet systems

SINAMICS G180 compact units

Selection and ordering data

400 V, 6-pulse

SINAMICS G180 compact unit (230 to 500 V 3 AC TN/TT system, 50 to 60 Hz)

Converter type	Connected load kVA	Output		Type rating ²⁾ kW	SINAMICS G180 compact units Article No.	Version (see options)
		Continuous current A	Short-time current ¹⁾ A			
2T2A-07400-002	3.7	5.5	6.5	2.2	6SE0100-1AC15-5AA7	A
2T2A-07400-003	4.6	7	8	3	6SE0100-1AC17-0AA7	A
2T2A-07400-004	6.4	9.5	11	4	6SE0100-1AC21-0AA7	A
2T2A-07400-005	8.6	13	15	5.5	6SE0100-1AC21-3AA7	A
2T2A-07400-007	12.1	18	20	7.5	6SE0100-1AC21-8AA7	A
2T2A-07400-011	16	24.5	27	11	6SE0100-1AC22-5AA7	A
2T2A-07400-015	24.4	37	44	15	6SE0100-1AC23-7AA7	B
2T2A-07400-022	32	48	54	22	6SE0100-1AC24-8AA7	B
2T2A-07400-030	39.2	58	63	30	6SE0100-1AC25-8AA7	B
2T2A-07400-037	52.3	78	88	37	6SE0100-1AC27-8AA7	B
2T2A-07400-045	57.5	88	110	45	6SE0100-1AC28-8AA7	B
2T2A-07400-055	74.8	110	126	55	6SE0100-1AC31-1AA7	B
2T2A-07400-075	98.4	145	165	75	6SE0100-1AC31-5AA7	C
2T2A-07400-090	119	175	204	90	6SE0100-1AC31-8AA7	C
2T2A-07400-110	136	205	240	110	6SE0100-1AC32-1AA7	C
2T2A-07400-132	161	245	300	132	6SE0100-1AC32-5AA7	D
2T2A-07400-160	197	295	360	160	6SE0100-1AC33-0AA7	D

500 V, 6-pulse

SINAMICS G180 compact unit (230 to 500 V 3 AC IT system, 50 to 60 Hz)

Converter type	Connected load kVA	Output		Type rating ²⁾ kW	SINAMICS G180 compact units Article No.	Version (see options)
		Continuous current A	Short-time current ¹⁾ A			
2T2A-07500-002	3.8	4.5	5	2.2	6SE0100-1AD14-5AA7	E
2T2A-07500-003	4.5	5.5	6.5	3	6SE0100-1AD15-5AA7	E
2T2A-07500-004	5.6	7	8	4	6SE0100-1AD17-0AA7	E
2T2A-07500-005	8.1	9.5	11	5.5	6SE0100-1AD21-0AA7	E
2T2A-07500-007	10.8	13	15	7.5	6SE0100-1AD21-3AA7	E
2T2A-07500-011	15.1	18	20	11	6SE0100-1AD21-8AA7	E
2T2A-07500-015	20.3	24.5	27	15	6SE0100-1AD22-5AA7	E
2T2A-07500-022	31.0	37	44	22	6SE0100-1AD23-7AA7	F
2T2A-07500-030	40.5	48	54	30	6SE0100-1AD24-8AA7	F
2T2A-07500-037	49.5	58	63	37	6SE0100-1AD25-8AA7	F
2T2A-07500-045	63.8	78	88	45	6SE0100-1AD27-8AA7	F
2T2A-07500-055	75.9	88	110	55	6SE0100-1AD28-8AA7	F
2T2A-07500-075	94.4	110	126	75	6SE0100-1AD31-1AA7	F
2T2A-07500-090	124	145	165	90	6SE0100-1AD31-5AA7	G
2T2A-07500-110	147	175	204	110	6SE0100-1AD31-8AA7	G
2T2A-07500-132	170	205	240	132	6SE0100-1AD32-1AA7	G
2T2A-07500-160	205	245	300	160	6SE0100-1AD32-5AA7	H
2T2A-07500-200	248	295	360	200	6SE0100-1AD33-0AA7	H

¹⁾ Short-time current for 60 s every 10 minutes.

²⁾ Rated power of a typical 2- to 6-pole standard motor.

Selection and ordering data

690 V, 6-pulse

SINAMICS G180 compact unit (230 to 690 V 3 AC TN/TT system, 50 to 60 Hz)

Converter type	Connected load kVA	Output		Type rating ²⁾ kW	SINAMICS G180 compact units Article No.	Version (see options)
		Continuous current A	Short-time current ¹⁾ A			
2T2A-07600-007	10.5	9.5	11	7.5	6SE0100-1AG21-0AA7	I
2T2A-07600-011	14.1	13	16	11	6SE0100-1AG21-3AA7	I
2T2A-07600-015	20.1	18	21	15	6SE0100-1AG21-8AA7	I
2T2A-07600-022	30.2	27	33	22	6SE0100-1AG22-5AA7	I
2T2A-07600-030	44.6	36	45	30	6SE0100-1AG23-4AA7	J
2T2A-07600-037	51.3	43	55	37	6SE0100-1AG24-2AA7	J
2T2A-07600-045	59.9	50	65	45	6SE0100-1AG25-0AA7	J
2T2A-07600-055	72.5	60	75	55	6SE0100-1AG25-8AA7	J
2T2A-07600-075	96.7	80	90	75	6SE0100-1AG28-0AA7	J
2T2A-07600-090	122	95	120	90	6SE0100-1AG31-0AA7	K
2T2A-07600-110	142	120	140	110	6SE0100-1AG31-2AA7	K
2T2A-07600-132	183	150	175	132	6SE0100-1AG31-4AA7	K
2T2A-07600-160	215	175	210	160	6SE0100-1AG31-7AA7	L
2T2A-07600-200	265	210	255	200	6SE0100-1AG32-1AA7	L

SINAMICS G180 compact unit (230 to 690 V 3 AC IT system, 50 to 60 Hz)

Converter type	Connected load kVA	Output		Type rating ²⁾ kW	SINAMICS G180 compact units Article No.	Version (see options)
		Continuous current A	Short-time current ¹⁾ A			
2T2A-07600-007	10.5	9.5	11	7.5	6SE0100-1AH21-0AA7	M
2T2A-07600-011	14.1	13	16	11	6SE0100-1AH21-3AA7	M
2T2A-07600-015	20.1	18	21	15	6SE0100-1AH21-8AA7	M
2T2A-07600-022	30.2	27	33	22	6SE0100-1AH22-5AA7	M
2T2A-07600-030	44.6	36	45	30	6SE0100-1AH23-4AA7	N
2T2A-07600-037	51.3	43	55	37	6SE0100-1AH24-2AA7	N
2T2A-07600-045	59.9	50	65	45	6SE0100-1AH25-0AA7	N
2T2A-07600-055	72.5	60	75	55	6SE0100-1AH25-8AA7	N
2T2A-07600-075	96.7	80	90	75	6SE0100-1AH28-0AA7	N
2T2A-07600-090	122	95	120	90	6SE0100-1AH31-0AA7	O
2T2A-07600-110	142	120	140	110	6SE0100-1AH31-2AA7	O
2T2A-07600-132	183	150	175	132	6SE0100-1AH31-4AA7	O
2T2A-07600-160	215	175	210	160	6SE0100-1AH31-7AA7	P
2T2A-07600-200	265	210	255	200	6SE0100-1AH32-1AA7	P

¹⁾ Short-time current for 60 s every 10 minutes.²⁾ Rated power of a typical 2- to 6-pole standard motor.

SINAMICS G180

SINAMICS G180 compact units and SINAMICS G180 cabinet systems

SINAMICS G180 compact units

Selection and ordering data

Article number code

Position of Article No.	1	2	3	4	5	6	7	8	9	10	11	12	13	14	15	16		
SINAMICS G180 compact unit	6	S	E	0	1	.	0	-	.	.	■	■	.	-	.	A	A	.
Mechanical design																		
Compact unit						0												
Line harmonics																		
6-pulse									1									
System																		
Compact unit										A								
Supply voltage																		
230 ... 500 V 3 AC TN/TT, 50 ... 60 Hz											C							
230 ... 500 V 3 AC IT, 50 ... 60 Hz											D							
230 ... 690 V 3 AC TN/TT, 50 ... 60 Hz											G							
230 ... 690 V 3 AC IT, 50 ... 60 Hz											H							
Code for output current																		
Multiplier for current value												1						
0.1												2						
1												3						
10												4						
100																		
Current value																		
Version/release number																		
Version/release number T7																7		

Number code for converter type

Position of converter type No.	1	2	3	4	5	6	7	8	9	10	11	12	
SINAMICS G180 compact unit	2	T	.	.	-	-	.	.	
Degree of protection													
IP20			2										
IP21			3										
Number of pulses in the input													
6-pulse input				A									
Mechanical design													
Compact device with air cooling						0							
Compact device with air cooling and with mounting (only applies to article numbers in conjunction with option S41)						2							
Modification status													
Modification status 7							7						
Line voltage													
400 V unit								4					
500 V unit								5					
690 V unit								6					
Number of parallel line-converter systems													
Single device without system management										0			
Number of parallel machine-converter systems													
Single device without system management											0		
Achievable type rating in kW with continuous output current													
If the 10th position of the article number is "9", the other two digits show the type rating in kW × 100.													

2

SINAMICS G180 compact units and SINAMICS G180 cabinet systems

SINAMICS G180 compact units

Options

The following tables provide an overview of the options and their availability for SINAMICS G180 compact units with a supply voltage of 400 V, 500 V or 690 V. (For details, see catalog chapter 4 "Option descriptions".)

Option text	Additional ordering data -Z with order code and, if necessary, with plain text specification	SINAMICS G180 compact units															
		400 V TN/TT system				500 V IT system				690 V TN/TT system				690 V IT system			
		Version – see selection and ordering data															
		A	B	C	D	E	F	G	H	I	J	K	L	M	N	O	P
External control voltage supply																	
Connection for 24 V DC control voltage provided by customer	C55	✓	✓	✓	✓	✓	✓	✓	✓	✓	✓	✓	✓	✓	✓	✓	✓
Connection for 230 V 1 AC 50 Hz control voltage provided by customer, without UPS backup	C56	✓	✓	✓	✓	✓	✓	✓	✓	✓	✓	✓	✓	✓	✓	✓	✓
Connection for 230 V 1 AC 50 Hz control voltage provided by customer, with UPS backup	C57	✓	✓	✓	✓	✓	✓	✓	✓	✓	✓	✓	✓	✓	✓	✓	✓
RFI suppression filter																	
RFI suppression filter, category C2 or C3 (class A)	L00	□	□	□	□	–	–	–	–	□	□	□	□	–	–	–	–
RFI suppression filter, category C1 (class B)	L02	✓	✓	✓	✓	–	–	–	–	–	–	–	–	–	–	–	–
Line Harmonics Filter (LHF)																	
LHF for operation at 380 ... 415 V 3 AC, 50 Hz (supplied separately packed)	L05	✓	✓	✓	✓	✓	✓	✓	✓	–	–	–	–	–	–	–	–
LHF for operation at 440 ... 500 V 3 AC, 50 Hz (supplied separately packed)	L06	✓	✓	✓	✓	✓	✓	✓	✓	–	–	–	–	–	–	–	–
LHF for operation at 440 ... 480 V 3 AC, 60 Hz (supplied separately packed)	L07	✓	✓	✓	✓	✓	✓	✓	✓	–	–	–	–	–	–	–	–
Output filter																	
Strengthened dv/dt output filter for max. 250/300 m (type-dependent). Design for longer motor cables available on request	L10	✓	✓	✓	✓	□	□	□	□	□	□	✓ ¹⁾	✓ ¹⁾	□	□	✓ ¹⁾	✓ ¹⁾
Sine-wave filter IP00 for compact unit, suitable for motor frequencies of ≤ 75 Hz, voltage drop of approximately 5 % of line voltage (supplied separately packed)	L16	✓	✓	✓	✓	✓	✓	✓	✓	✓	✓	✓	✓	✓	✓	✓	✓
Standard accessories packages																	
Main switch integrated into compact unit (might alter dimensions of unit)	S41	✓	✓	✓ ²⁾	–	✓	✓	✓ ²⁾	–	✓	✓	✓ ²⁾	–	✓	✓	✓ ²⁾	–
Braking chopper																	
Braking chopper integrated into converter (braking resistor is not included and must be ordered separately)	L72	□	✓	✓	✓	□	✓	✓	✓	✓	✓	✓	✓	✓	✓	✓	✓
Degrees of protection																	
Increased degree of protection IP21 for compact units	M21	✓	✓	✓	✓	✓	✓	✓	✓	✓	✓	✓	✓	✓	✓	✓	✓
Other options																	
Board for mains supply backup	E85	x	x	x	x	x	x	x	x	□	✓	✓	✓	□	✓	✓	✓
External 4-line operator panel, supplied separately packed	K14	✓	✓	✓	✓	✓	✓	✓	✓	✓	✓	✓	✓	✓	✓	✓	✓
DC link connected to terminals	N39	□	□	□	□	□	□	□	□	□	□	□	□	□	□	□	□
Peripheral boards																	
Peripheral board 1	G02	✓	✓	✓	✓	✓	✓	✓	✓	✓	✓	✓	✓	✓	✓	✓	✓
Peripheral board 2	G03	✓	✓	✓	✓	✓	✓	✓	✓	✓	✓	✓	✓	✓	✓	✓	✓
Peripheral board 3	G04	✓	✓	✓	✓	✓	✓	✓	✓	✓	✓	✓	✓	✓	✓	✓	✓
Peripheral board 4	G05	✓	✓	✓	✓	✓	✓	✓	✓	✓	✓	✓	✓	✓	✓	✓	✓
Additional boards for bus connection																	
Board for PROFIBUS DPV1	G01	✓	✓	✓	✓	✓	✓	✓	✓	✓	✓	✓	✓	✓	✓	✓	✓
Board for PROFINET	G06	✓	✓	✓	✓	✓	✓	✓	✓	✓	✓	✓	✓	✓	✓	✓	✓
Board for CANopen	G20	✓	✓	✓	✓	✓	✓	✓	✓	✓	✓	✓	✓	✓	✓	✓	✓
Board for Modbus RTU	G22	✓	✓	✓	✓	✓	✓	✓	✓	✓	✓	✓	✓	✓	✓	✓	✓
Board for Modbus TCP	G27	✓	✓	✓	✓	✓	✓	✓	✓	✓	✓	✓	✓	✓	✓	✓	✓

For legends and footnotes, see Page 2/21.

SINAMICS G180

SINAMICS G180 compact units and SINAMICS G180 cabinet systems

SINAMICS G180 compact units

Options

Option text	Additional ordering data -Z with order code and, if necessary, with plain text specification	SINAMICS G180 compact units															
		400 V TN/TT system				500 V IT system				690 V TN/TT system				690 V IT system			
		A	B	C	D	E	F	G	H	I	J	K	L	M	N	O	P
Accessories for IMS																	
USB PROFIBUS interface (supplied separately packed)	G13	✓	✓	✓	✓	✓	✓	✓	✓	✓	✓	✓	✓	✓	✓	✓	✓
Ethernet-PROFIBUS gateway	G14	✓	✓	✓	✓	✓	✓	✓	✓	✓	✓	✓	✓	✓	✓	✓	✓
Ethernet-to-RS232/485/422 converter (supplied separately packed)	G15	✓	✓	✓	✓	✓	✓	✓	✓	✓	✓	✓	✓	✓	✓	✓	✓
USB cable A/B (supplied separately packed)	G16	✓	✓	✓	✓	✓	✓	✓	✓	✓	✓	✓	✓	✓	✓	✓	✓
Extension of the liability for defects																	
Extension of the liability for defects period by 12 months to a total of 24 months (2 years) after being delivered	Q80	✓	✓	✓	✓	✓	✓	✓	✓	✓	✓	✓	✓	✓	✓	✓	✓
Extension of the liability for defects period by 18 months to a total of 30 months (2½ years) after being delivered	Q81	✓	✓	✓	✓	✓	✓	✓	✓	✓	✓	✓	✓	✓	✓	✓	✓
Extension of the liability for defects period by 24 months to a total of 36 months (3 years) after being delivered	Q82	✓	✓	✓	✓	✓	✓	✓	✓	✓	✓	✓	✓	✓	✓	✓	✓
Extension of the liability for defects period by 30 months to a total of 42 months (3½ years) after being delivered	Q83	✓	✓	✓	✓	✓	✓	✓	✓	✓	✓	✓	✓	✓	✓	✓	✓
Extension of the liability for defects period by 36 months to a total of 48 months (4 years) after being delivered	Q84	✓	✓	✓	✓	✓	✓	✓	✓	✓	✓	✓	✓	✓	✓	✓	✓
Extension of the liability for defects period by 48 months to a total of 60 months (5 years) after being delivered	Q85	✓	✓	✓	✓	✓	✓	✓	✓	✓	✓	✓	✓	✓	✓	✓	✓
Ambient temperature for air-cooled converters																	
45 °C ambient temperature (with corresponding derating)	V61	✓	✓	✓	✓	✓	✓	✓	✓	✓	✓	✓	✓	✓	✓	✓	✓
50 °C ambient temperature (with corresponding derating)	V62	✓	✓	✓	✓	✓	✓	✓	✓	✓	✓	✓	✓	✓	✓	✓	✓
55 °C ambient temperature (for compact units with corresponding derating only)	V63	✓	✓	✓	✓	✓	✓	✓	✓	✓	✓	✓	✓	✓	✓	✓	✓
Installation altitude																	
Installation altitude max. 1500 m above sea level (with corresponding derating)	V86	✓	✓	✓	✓	✓	✓	✓	✓	✓	✓	✓	✓	✓	✓	✓	✓
Installation altitude max. 2000 m above sea level (with corresponding derating)	V87	✓	✓	✓	✓	✓	✓	✓	✓	✓	✓	✓	✓	✓	✓	✓	✓
Installation altitude max. 2500 m above sea level (with corresponding derating)	V88	✓	✓	✓	✓	✓	✓	✓	✓	✓	✓	✓	✓	✓	✓	✓	✓
Installation altitude max. 3000 m above sea level (with corresponding derating)	V89	✓	✓	✓	✓	✓	✓	✓	✓	✓	✓	✓	✓	✓	✓	✓	✓

For legends and footnotes, see Page 2/21.

Options

Option text	Additional ordering data -Z with order code and, if necessary, with plain text specification	SINAMICS G180 compact units															
		400 V TN/TT system				500 V IT system				690 V TN/TT system				690 V IT system			
		Version – see selection and ordering data															
		A	B	C	D	E	F	G	H	I	J	K	L	M	N	O	P
Supplementary documentation																	
Test sequence schedule	B48	✓	✓	✓	✓	✓	✓	✓	✓	✓	✓	✓	✓	✓	✓	✓	✓
Spare parts price list	B38	✓	✓	✓	✓	✓	✓	✓	✓	✓	✓	✓	✓	✓	✓	✓	✓
Converter display language																	
Display language Norwegian/English	T23	✓	✓	✓	✓	✓	✓	✓	✓	✓	✓	✓	✓	✓	✓	✓	✓
Display language Swedish/English	T24	✓	✓	✓	✓	✓	✓	✓	✓	✓	✓	✓	✓	✓	✓	✓	✓
Display language Czech/English	T25	✓	✓	✓	✓	✓	✓	✓	✓	✓	✓	✓	✓	✓	✓	✓	✓
Display language Hungarian/English	T26	✓	✓	✓	✓	✓	✓	✓	✓	✓	✓	✓	✓	✓	✓	✓	✓
Display language French/English	T58	✓	✓	✓	✓	✓	✓	✓	✓	✓	✓	✓	✓	✓	✓	✓	✓
Display language Spanish/English	T60	✓	✓	✓	✓	✓	✓	✓	✓	✓	✓	✓	✓	✓	✓	✓	✓
Display language German/English	T74	✓	✓	✓	✓	✓	✓	✓	✓	✓	✓	✓	✓	✓	✓	✓	✓
Display language English/German	T76	✓	✓	✓	✓	✓	✓	✓	✓	✓	✓	✓	✓	✓	✓	✓	✓
Display language Portuguese/English	T82	✓	✓	✓	✓	✓	✓	✓	✓	✓	✓	✓	✓	✓	✓	✓	✓
Display language Russian/English	T85	✓	✓	✓	✓	✓	✓	✓	✓	✓	✓	✓	✓	✓	✓	✓	✓
Display language Polish/English	T86	✓	✓	✓	✓	✓	✓	✓	✓	✓	✓	✓	✓	✓	✓	✓	✓
Second display language other than English	Y14	✓	✓	✓	✓	✓	✓	✓	✓	✓	✓	✓	✓	✓	✓	✓	✓
Language of assembly and operating instructions																	
Different language for assembly and operating instructions	Y13 • and identification code	✓	✓	✓	✓	✓	✓	✓	✓	✓	✓	✓	✓	✓	✓	✓	✓
Certifications																	
EAC certificate	U04	✓	✓	✓	✓	✓	✓	✓	✓	✓	✓	✓	✓	✓	✓	✓	✓
Engineering (for description, see Page 4/33)																	
Extended overvoltage range		✓	✓	✓	✓	– ³⁾	– ³⁾	– ³⁾	– ³⁾	✓	✓	✓	✓	✓	✓	✓	✓

✓ Available

□ Standard version

– Not possible

× Not required

• This order code only determines the price of the version – additional plain text is required.

1) More powerful dv/dt output filter is supplied separately packed with the compact unit.

2) Frame size K51

3) 690 V compact units + the next-higher rating must be selected for the "Extended overvoltage range" function.

SINAMICS G180

SINAMICS G180 compact units and SINAMICS G180 cabinet systems

SINAMICS G180 compact units

Dimensional drawings

Frame size K1

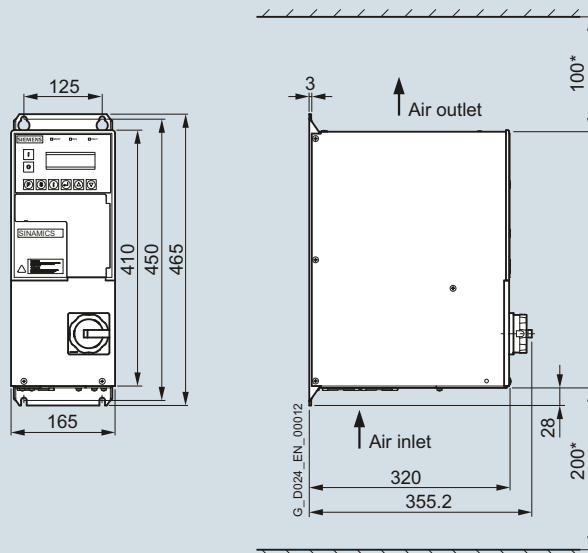

* Minimum clearance for air inlet and air outlet

Main switch is integrated in the compact unit only with option **S41**.

SINAMICS G180 compact units	Converter type
6SE0100-1AC15-5AA7	2T2A-07400-002
6SE0100-1AC17-0AA7	2T2A-07400-003
6SE0100-1AC21-0AA7	2T2A-07400-004
6SE0100-1AC21-3AA7	2T2A-07400-005
6SE0100-1AD14-5AA7	2T2A-07500-002
6SE0100-1AD15-5AA7	2T2A-07500-003
6SE0100-1AD17-0AA7	2T2A-07500-004
6SE0100-1AD21-0AA7	2T2A-07500-005
6SE0100-1AD21-3AA7	2T2A-07500-007

SINAMICS G180

SINAMICS G180 compact units and SINAMICS G180 cabinet systems

SINAMICS G180 compact units

Dimensional drawings

Frame size K2

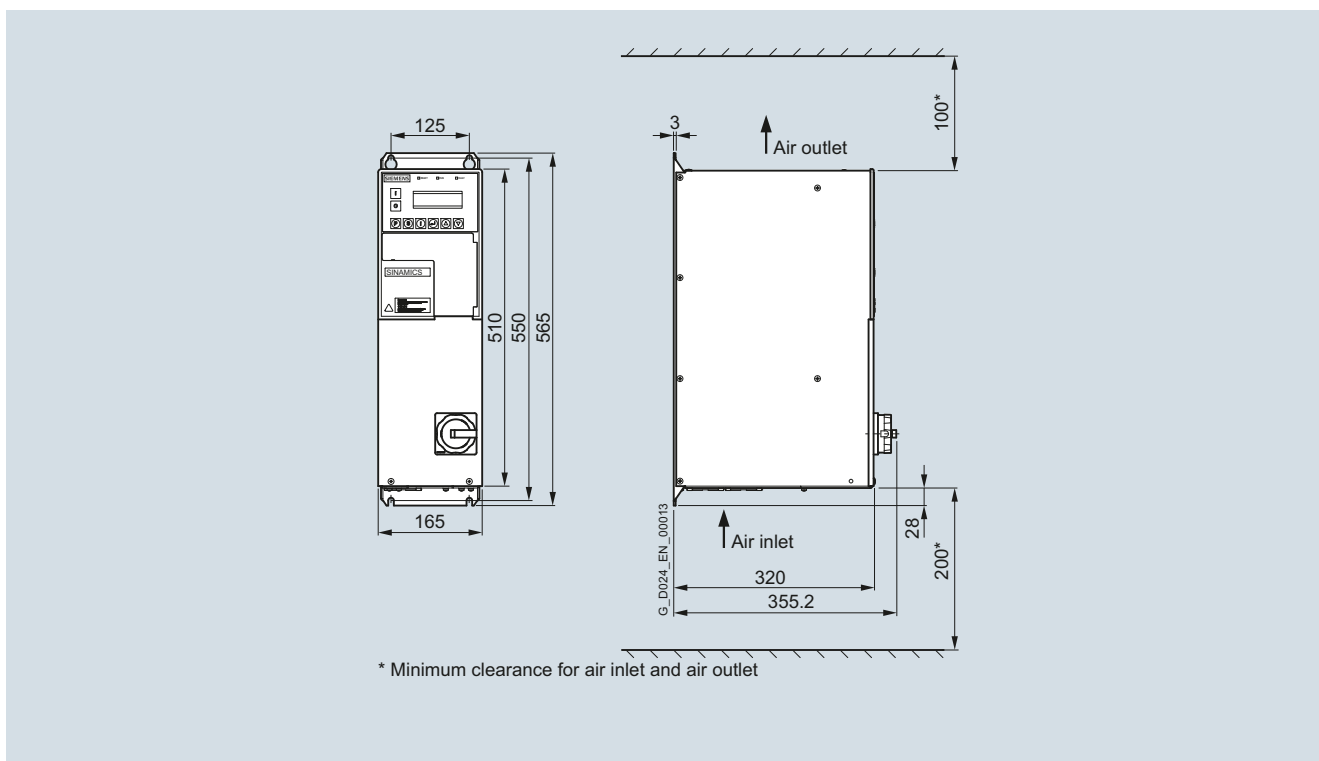

Main switch is integrated in the compact unit only with option **S41**.

SINAMICS G180 compact units	Converter type
6SE0100-1AC21-8AA7	2T2A-07400-007
6SE0100-1AC22-5AA7	2T2A-07400-011
6SE0100-1AD21-8AA7	2T2A-07500-011
6SE0100-1AD22-5AA7	2T2A-07500-015

SINAMICS G180

SINAMICS G180 compact units and SINAMICS G180 cabinet systems

SINAMICS G180 compact units

Dimensional drawings

Frame size K3

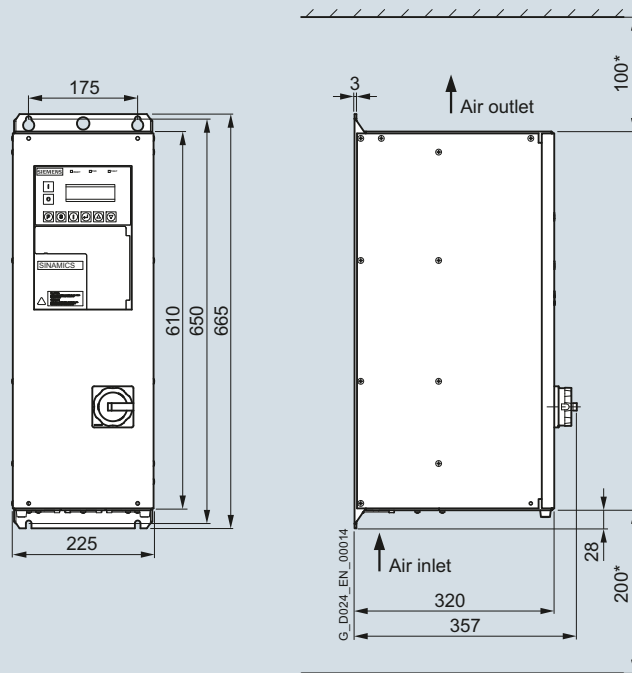

* Minimum clearance for air inlet and air outlet

Main switch is integrated in the compact unit only with option **S41**.

SINAMICS G180 compact units	Converter type
6SE0100-1AC23-7AA7	2T2A-07400-015
6SE0100-1AC24-8AA7	2T2A-07400-022
6SE0100-1AC25-8AA7	2T2A-07400-030
6SE0100-1AD23-7AA7	2T2A-07500-022
6SE0100-1AD24-8AA7	2T2A-07500-030
6SE0100-1AD25-8AA7	2T2A-07500-037
6SE0100-1A■21-0AA7	2T2A-07600-007
6SE0100-1A■21-3AA7	2T2A-07600-011
6SE0100-1A■21-8AA7	2T2A-07600-015
6SE0100-1A■22-5AA7	2T2A-07600-022

Dimensional drawings

Frame size K4

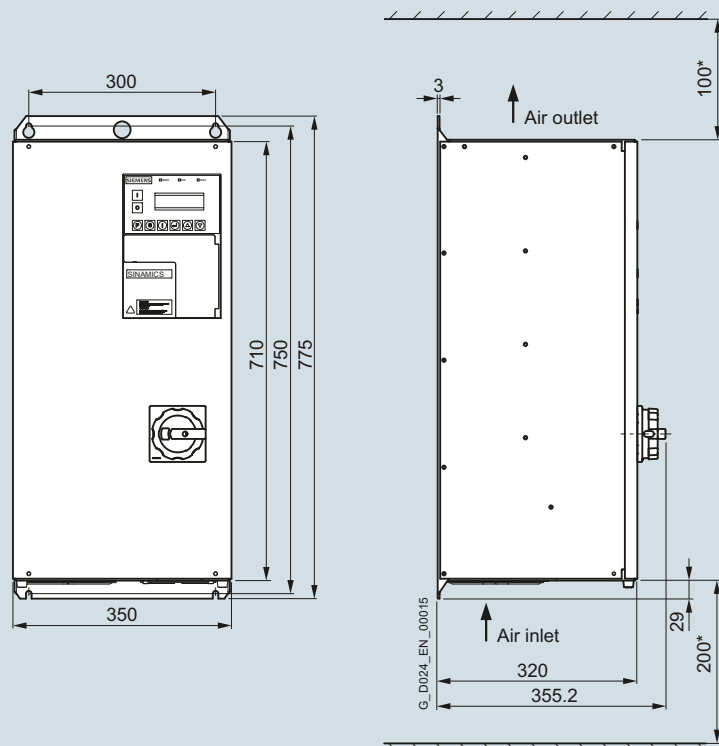

* Minimum clearance for air inlet and air outlet

Main switch is integrated in the compact unit only with option **S41**.

SINAMICS G180 compact units	Converter type
6SE0100-1AC27-8AA7	2T2A-07400-037
6SE0100-1AC28-8AA7	2T2A-07400-045
6SE0100-1AC31-1AA7	2T2A-07400-055
6SE0100-1AD27-8AA7	2T2A-07500-045
6SE0100-1AD28-8AA7	2T2A-07500-055
6SE0100-1AD31-1AA7	2T2A-07500-075
6SE0100-1A■23-4AA7	2T2A-07600-030
6SE0100-1A■28-0AA7	2T2A-07600-075

SINAMICS G180

SINAMICS G180 compact units and SINAMICS G180 cabinet systems

SINAMICS G180 compact units

Dimensional drawings

Frame size K5

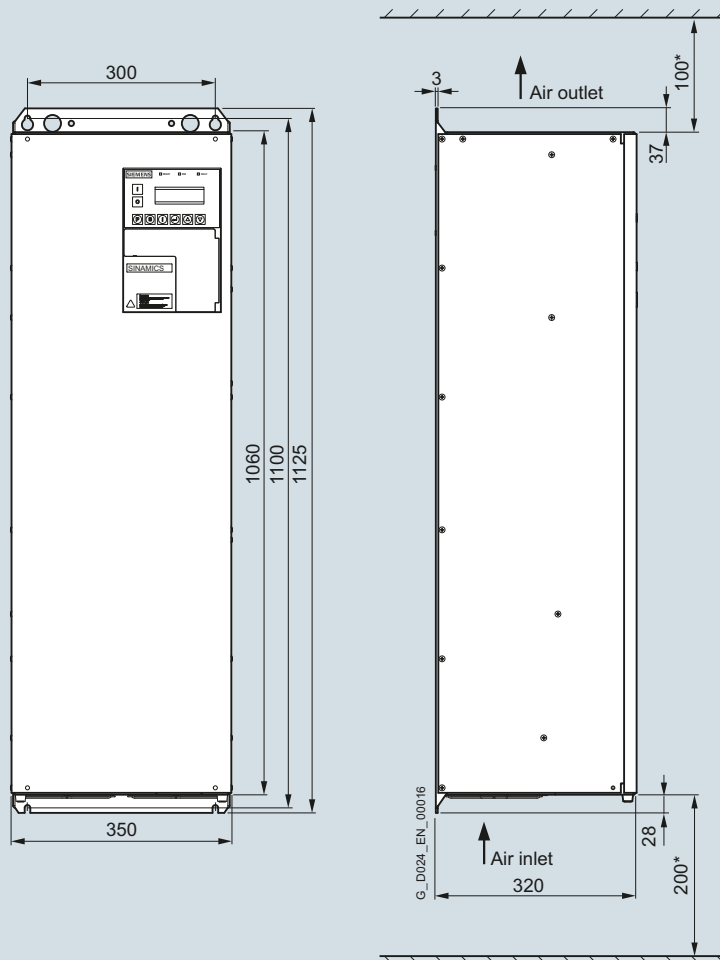

* Minimum clearance for air inlet and air outlet

SINAMICS G180 compact units	Converter type
6SE0100-1AC31-5AA7	2T2A-07400-075
6SE0100-1AC31-8AA7	2T2A-07400-090
6SE0100-1AC32-1AA7	2T2A-07400-110
6SE0100-1AD31-5AA7	2T2A-07500-090
6SE0100-1AD31-8AA7	2T2A-07500-110
6SE0100-1AD32-1AA7	2T2A-07500-132
6SE0100-1A31-0AA7	2T2A-07600-090
6SE0100-1A31-2AA7	2T2A-07600-110
6SE0100-1A31-4AA7	2T2A-07600-132

SINAMICS G180 compact units and SINAMICS G180 cabinet systems

SINAMICS G180 compact units

Dimensional drawings

Frame size K51

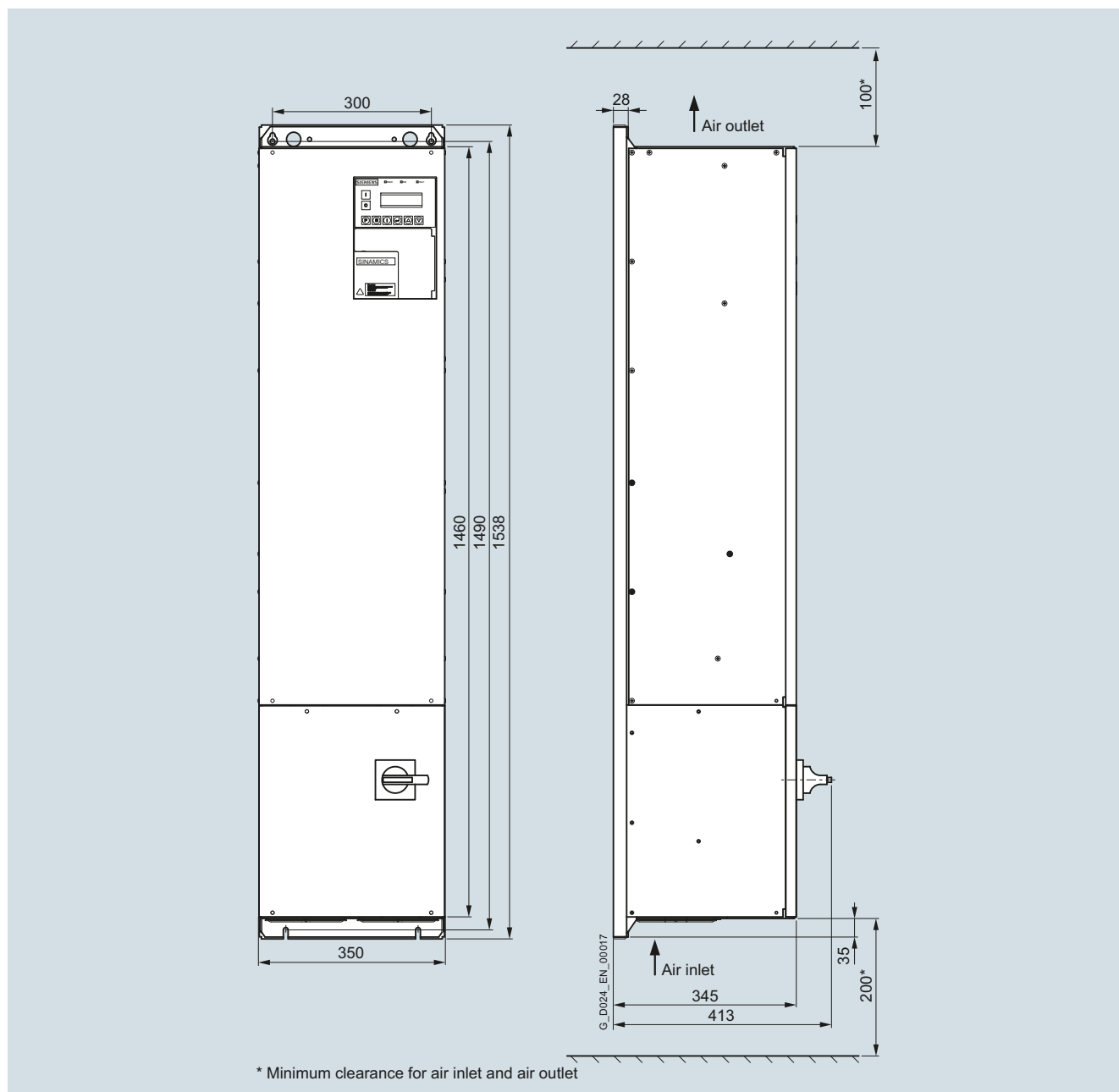

Main switch is integrated as standard in compact units of frame size K51

SINAMICS G180 compact units	Converter type
6SE0100-1AC31-5AA7 +S41	2T2A-27400-275
6SE0100-1AC31-8AA7 +S41	2T2A-27400-090
6SE0100-1AC32-1AA7 +S41	2T2A-27400-110
6SE0100-1AD31-5AA7 +S41	2T2A-27500-090
6SE0100-1AD31-8AA7 +S41	2T2A-27500-110
6SE0100-1AD32-1AA7 +S41	2T2A-27500-132
6SE0100-1A31-0AA7 +S41	2T2A-27600-090
6SE0100-1A31-2AA7 +S41	2T2A-27600-110
6SE0100-1A31-4AA7 +S41	2T2A-27600-132

SINAMICS G180

SINAMICS G180 compact units and SINAMICS G180 cabinet systems

SINAMICS G180 compact units

Dimensional drawings

Frame size K6

2

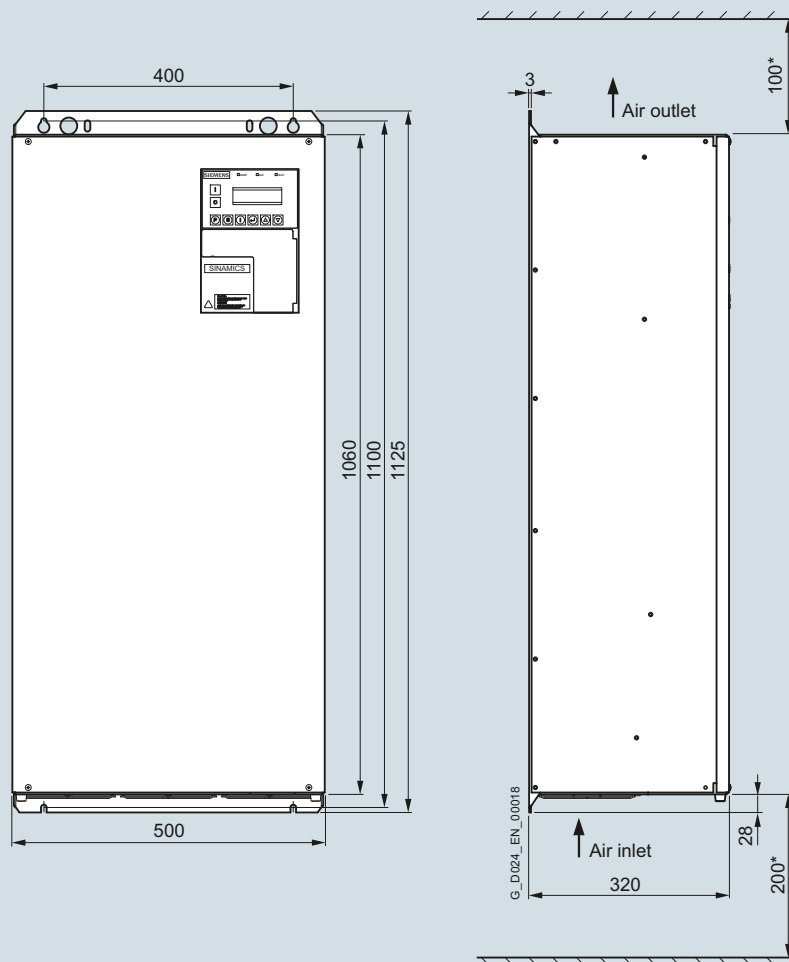

* Minimum clearance for air inlet and air outlet

SINAMICS G180 compact units	Converter type
6SE0100-1AC32-5AA7	2T2A-07400-132
6SE0100-1AC33-0AA7	2T2A-07400-160
6SE0100-1AD32-5AA7	2T2A-07500-160
6SE0100-1AD33-0AA7	2T2A-07500-200
6SE0100-1A■31-7AA7	2T2A-07600-160
6SE0100-1A■32-1AA7	2T2A-07600-200

SINAMICS G180 compact units and SINAMICS G180 cabinet systems

SINAMICS G180 cabinet systems

Overview

SINAMICS G180 cabinet systems comprise SINAMICS G180 compact units which are combined with Rittal TS8 cabinets and customer-specific control accessories to create individual cabinet systems.

Global use

SINAMICS G180 converter cabinet systems are manufactured in compliance with relevant international standards and regulations, and are therefore suitable for global use (see technical data).



SINAMICS G180 – cabinet system with four compact units

Design

- Modular principle permits the design of cost-optimized, customized systems
- A complete installation can be quickly and easily assembled through the integration of various industry-specific control packages
- Use of CAE/CAM systems increases flexibility and shortens delivery times
- Capable of integration in any control concept thanks to customized design
- Capable of adaptation to numerous bus systems
- Overall concept is devised to minimize space requirements
- Rittal TS8 cabinet system ensures acceptance anywhere in the world
- Optimum use of space thanks to different cabinet sizes
- Easy to adapt to an extensive range of climatic conditions
- Quick access to all components from front of cabinet eases maintenance
- Additional fans are not generally required
- Cable entry from below incl. cable clamping bar, shielding bus and grounding bar

Number of compact units in cabinet system (depending on width)

Compact units	Cabinet system width			
	600 mm	800 mm	1000 mm	1200 mm
165 mm wide 2.2 ... 11 kW (400 V) 2.2 ... 15 kW (500 V)	3	4	5	6
225 mm wide 15 ... 30 kW (400 V) 22 ... 37 kW (500 V) 7.5 ... 22 kW (690 V)	2	3	4	4
350 mm wide 37 ... 110 kW (400 V) 45 ... 132 kW (500 V) 30 ... 132 kW (690 V)	1	2	2	3
500 mm wide 132 ... 160 kW (400 V) 160 ... 200 kW (500 V) 160 ... 200 kW (690 V)	1	1	1	2

This overview applies to cabinet systems without an additional control system (except for option S31). We would be happy to assist with optimization of the cabinet system width.

SINAMICS G180

SINAMICS G180 compact units and SINAMICS G180 cabinet systems

SINAMICS G180 cabinet systems

Selection and ordering data

400 V, 6-pulse

SINAMICS G180 compact unit in control cabinet (230 to 500 V 3 AC TN/TT system, 50 to 60 Hz)

Converter type	Connected load kVA	Output			SINAMICS G180 cabinet systems	Version (see options)
		Continuous current A	Short-time current ¹⁾ A	Type rating ²⁾ kW		
2X3A-8740 ■ -002	3.7	5.5	6.5	2.2	6SE0140-1 ■ C15-5AA7	A
2X3A-8740 ■ -003	4.6	7	8	3	6SE0140-1 ■ C17-0AA7	A
2X3A-8740 ■ -004	6.4	9.5	11	4	6SE0140-1 ■ C21-0AA7	A
2X3A-8740 ■ -005	8.6	13	15	5.5	6SE0140-1 ■ C21-3AA7	A
2X3A-8740 ■ -007	12.1	18	20	7.5	6SE0140-1 ■ C21-8AA7	A
2X3A-8740 ■ -011	16	24.5	27	11	6SE0140-1 ■ C22-5AA7	A
2X3A-8740 ■ -015	24.4	37	44	15	6SE0140-1 ■ C23-7AA7	B
2X3A-8740 ■ -022	32	48	54	22	6SE0140-1 ■ C24-8AA7	C
2X3A-8740 ■ -030	39.2	58	63	30	6SE0140-1 ■ C25-8AA7	C
2X3A-8740 ■ -037	52.3	78	88	37	6SE0140-1 ■ C27-8AA7	D
2X3A-8740 ■ -045	57.5	88	110	45	6SE0140-1 ■ C28-8AA7	D
2X3A-8740 ■ -055	74.8	110	126	55	6SE0140-1 ■ C31-1AA7	D
2X3A-8740 ■ -075	98.4	145	165	75	6SE0140-1 ■ C31-5AA7	E
2X3A-8740 ■ -090	119	175	204	90	6SE0140-1 ■ C31-8AA7	E
2X3A-8740 ■ -110	136	205	240	110	6SE0140-1 ■ C32-1AA7	E
2X3A-8740 ■ -132	161	245	300	132	6SE0140-1 ■ C32-5AA7	F
2X3A-8740 ■ -160	197	295	360	160	6SE0140-1 ■ C33-0AA7	F

See number code for converter type and article number code on Page 2/32

500 V, 6-pulse

SINAMICS G180 compact unit in control cabinet (230 to 500 V 3 AC IT system, 50 to 60 Hz)

Converter type	Connected load kVA	Output			SINAMICS G180 cabinet systems	Version (see options)
		Continuous current A	Short-time current ¹⁾ A	Type rating ²⁾ kW		
2X3A-8750 ■ -002	3.8	4.5	5	2.2	6SE0140-1 ■ D14-5AA7	G
2X3A-8750 ■ -003	4.5	5.5	6.5	3	6SE0140-1 ■ D15-5AA7	G
2X3A-8750 ■ -004	5.8	7	8	4	6SE0140-1 ■ D17-0AA7	G
2X3A-8750 ■ -005	8.2	9.5	11	5.5	6SE0140-1 ■ D21-0AA7	G
2X3A-8750 ■ -007	10.9	13	15	7.5	6SE0140-1 ■ D21-3AA7	G
2X3A-8750 ■ -011	15.2	18	20	11	6SE0140-1 ■ D21-8AA7	G
2X3A-8750 ■ -015	20.4	24.5	27	15	6SE0140-1 ■ D22-5AA7	G
2X3A-8750 ■ -022	31.3	37	44	22	6SE0140-1 ■ D23-7AA7	H
2X3A-8750 ■ -030	40.5	48	54	30	6SE0140-1 ■ D24-8AA7	I
2X3A-8750 ■ -037	49.6	58	63	37	6SE0140-1 ■ D25-8AA7	I
2X3A-8750 ■ -045	64.2	78	88	45	6SE0140-1 ■ D27-8AA7	J
2X3A-8750 ■ -055	76.1	88	110	55	6SE0140-1 ■ D28-8AA7	J
2X3A-8750 ■ -075	94.4	110	126	75	6SE0140-1 ■ D31-1AA7	J
2X3A-8750 ■ -090	124	145	165	90	6SE0140-1 ■ D31-5AA7	K
2X3A-8750 ■ -110	147	175	204	110	6SE0140-1 ■ D31-8AA7	K
2X3A-8750 ■ -132	171	205	240	132	6SE0140-1 ■ D32-1AA7	K
2X3A-8750 ■ -160	206	245	300	160	6SE0140-1 ■ D32-5AA7	L
2X3A-8750 ■ -200	248	295	360	200	6SE0140-1 ■ D33-0AA7	L

See number code for converter type and article number code on Page 2/32

¹⁾ Short-time current for 60 s every 10 minutes.

²⁾ Rated power of a typical 2- to 6-pole standard motor.

Selection and ordering data

690 V, 6-pulse

SINAMICS G180 compact unit in control cabinet (230 to 690 V 3 AC TN/TT system, 50 to 60 Hz)

Converter type	Connected load kVA	Output			SINAMICS G180 cabinet systems	Version (see options)
		Continuous current A	Short-time current ¹⁾ A	Type rating ²⁾ kW		
2X3A-8769 ■ -007	10.8	9.5	11	7.5	6SE0140-1 ■ G21-0AA7	M
2X3A-8769 ■ -011	14.3	13	16	11	6SE0140-1 ■ G21-3AA7	M
2X3A-8769 ■ -015	20.3	18	21	15	6SE0140-1 ■ G21-8AA7	N
2X3A-8769 ■ -022	30.5	27	33	22	6SE0140-1 ■ G22-5AA7	N
2X3A-8769 ■ -030	45.5	36	45	30	6SE0140-1 ■ G23-4AA7	O
2X3A-8769 ■ -037	52.6	43	55	37	6SE0140-1 ■ G24-2AA7	O
2X3A-8769 ■ -045	60.9	50	65	45	6SE0140-1 ■ G25-0AA7	O
2X3A-8769 ■ -055	74	60	75	55	6SE0140-1 ■ G25-8AA7	O
2X3A-8769 ■ -075	97.9	80	90	75	6SE0140-1 ■ G28-0AA7	O
2X3A-8769 ■ -090	123	95	120	90	6SE0140-1 ■ G31-0AA7	P
2X3A-8769 ■ -110	143	120	140	110	6SE0140-1 ■ G31-2AA7	P
2X3A-8769 ■ -132	184	150	175	132	6SE0140-1 ■ G31-4AA7	P
2X3A-8769 ■ -160	216	175	210	160	6SE0140-1 ■ G31-7AA7	Q
2X3A-8769 ■ -200	266	210	255	200	6SE0140-1 ■ G32-1AA7	Q

See number code for converter type and article number code on Page 2/32

SINAMICS G180 compact unit in control cabinet (230 to 690 V 3 AC IT system, 50 to 60 Hz)

Converter type	Connected load kVA	Output			SINAMICS G180 cabinet systems	Version (see options)
		Continuous current A	Short-time current ¹⁾ A	Type rating ²⁾ kW		
2X3A-8769 ■ -007	10.8	9.5	11	7.5	6SE0140-1 ■ H21-0AA7	R
2X3A-8769 ■ -011	14.3	13	16	11	6SE0140-1 ■ H21-3AA7	R
2X3A-8769 ■ -015	20.3	18	21	15	6SE0140-1 ■ H21-8AA7	S
2X3A-8769 ■ -022	30.5	27	33	22	6SE0140-1 ■ H22-5AA7	S
2X3A-8769 ■ -030	45.5	36	45	30	6SE0140-1 ■ H23-4AA7	T
2X3A-8769 ■ -037	52.6	43	55	37	6SE0140-1 ■ H24-2AA7	T
2X3A-8769 ■ -045	60.9	50	65	45	6SE0140-1 ■ H25-0AA7	T
2X3A-8769 ■ -055	74	60	75	55	6SE0140-1 ■ H25-8AA7	T
2X3A-8769 ■ -075	97.9	80	90	75	6SE0140-1 ■ H28-0AA7	T
2X3A-8769 ■ -090	123	95	120	90	6SE0140-1 ■ H31-0AA7	U
2X3A-8769 ■ -110	143	120	140	110	6SE0140-1 ■ H31-2AA7	U
2X3A-8769 ■ -132	184	150	175	132	6SE0140-1 ■ H31-4AA7	U
2X3A-8769 ■ -160	216	175	210	160	6SE0140-1 ■ H31-7AA7	V
2X3A-8769 ■ -200	266	210	255	200	6SE0140-1 ■ H32-1AA7	V

See number code for converter type and article number code on Page 2/32

1) Short-time current for 60 s every 10 minutes.

2) Rated power of a typical 2- to 6-pole standard motor.

SINAMICS G180

SINAMICS G180 compact units and SINAMICS G180 cabinet systems

SINAMICS G180 cabinet systems

Selection and ordering data

Article number code

Position of Article No.	1	2	3	4	5	6	7	8	9	10	11	12	13	14	15	16		
SINAMICS G180 cabinet system	6	S	E	0	1	.	0	-	.	■	■	■	.	-	.	A	A	.
Mechanical design																		
Cabinet with compact units						4												
Line harmonics																		
6-pulse									1									
Number of parallel connected systems																		
Cabinet with one compact unit										K								
Cabinet with two compact units ¹⁾										L								
Cabinet with 3 identical compact units ¹⁾										M								
Cabinet with 4 identical compact units ¹⁾										N								
Cabinet with 5 identical compact units ¹⁾										P								
Cabinet with 6 identical compact units ¹⁾										Q								
Cabinet with various compact units ¹⁾²⁾										Y								
Supply voltage																		
230 ... 500 V 3 AC TN/TT, 50 ... 60 Hz													C					
230 ... 500 V 3 AC IT, 50 ... 60 Hz													D					
230 ... 690 V 3 AC TN/TT, 50 ... 60 Hz													G					
230 ... 690 V 3 AC IT, 50 ... 60 Hz													H					
Code for output current																		
<u>Multiplier for current value</u>																		
0.1																		1
1																		2
10																		3
100																		4
<u>Current value</u>																		
Version/release number																		
Version/release number T7																		

Number code for converter type

Position of <i>converter type</i> No.	1	2	3	4	5	6	7	8	9	10	11	12
SINAMICS G180 cabinet system	2	X	.	.	-	.	.	.	■	-	.	.
Degree of protection												
IP21			3									
IP54			6									
IP55			7									
Different degree of protection (e.g. IP43)			9									
Number of pulses in the input and output												
6-pulse input and output				A								
Mechanical design												
Cabinet system with air cooling						8						
Modification status												
Modification status 7							7					
Line voltage												
400 V unit								4	0			
500 V unit								5	0			
690 V unit								6	9			
Number of integrated converters												
Number of converters									.			
Achievable type rating in kW with continuous output current												
If the 10th position of the article number is "9", the other two digits show the type rating in kW × 100.												

¹⁾ Not yet available, on request.

²⁾ When ordering, please state the number of compact units in the control cabinet and their individual ratings.

Options

The following tables provide an overview of the options and their availability for SINAMICS G180 compact units in control cabinets (cabinet systems) with a supply voltage of 400 V, 500 V or 690 V. (For details, see catalog chapter 4 "Option descriptions".)

Option text	Additional ordering data -Z with order code and, if necessary, with plain text specification	SINAMICS G180 cabinet systems (compact units installed in a control cabinet)											
		400 V TN/TT system						500 V IT system					
		Version – see selection and ordering data											
		A	B	C	D	E	F	G	H	I	J	K	L
Converter cabinet width													
406 mm	H80	✓	✓	✓	–	–	–	✓	✓	✓	–	–	–
606 mm	H81	□	□	□	□	□	□	□	□	□	□	□	□
806 mm	H82	✓	✓	✓	✓	✓	✓	✓	✓	✓	✓	✓	✓
1006 mm	H83	✓	✓	✓	✓	✓	✓	✓	✓	✓	✓	✓	✓
1206 mm	H84	✓	✓	✓	✓	✓	✓	✓	✓	✓	✓	✓	✓
1406 mm	H85	✓	✓	✓	✓	✓	✓	✓	✓	✓	✓	✓	✓
1606 mm	H86	✓	✓	✓	✓	✓	✓	✓	✓	✓	✓	✓	✓
Additional cabinet													
400 mm	H90	✓	✓	✓	✓	✓	✓	✓	✓	✓	✓	✓	✓
600 mm	H91	✓	✓	✓	✓	✓	✓	✓	✓	✓	✓	✓	✓
800 mm	H92	✓	✓	✓	✓	✓	✓	✓	✓	✓	✓	✓	✓
1000 mm	H93	✓	✓	✓	✓	✓	✓	✓	✓	✓	✓	✓	✓
1200 mm	H94	✓	✓	✓	✓	✓	✓	✓	✓	✓	✓	✓	✓
Line voltages													
Line voltage 380 V, 50 Hz	V70	✓	✓	✓	✓	✓	✓	✓	✓	✓	✓	✓	✓
Line voltage 400 V, 50 Hz	V71	✓	✓	✓	✓	✓	✓	✓	✓	✓	✓	✓	✓
Line voltage 415 V, 50 Hz	V72	✓	✓	✓	✓	✓	✓	✓	✓	✓	✓	✓	✓
Line voltage 500 V, 50 Hz	V73	✓	✓	✓	✓	✓	✓	✓	✓	✓	✓	✓	✓
Line voltage 660 V, 50 Hz	V74	–	–	–	–	–	–	–	–	–	–	–	–
Line voltage 690 V, 50 Hz	V75	–	–	–	–	–	–	–	–	–	–	–	–
Line voltage 440 V, 60 Hz	V76	✓	✓	✓	✓	✓	✓	✓	✓	✓	✓	✓	✓
Line voltage 460 V, 60 Hz	V77	✓	✓	✓	✓	✓	✓	✓	✓	✓	✓	✓	✓
Line voltage 480 V, 60 Hz	V78	✓	✓	✓	✓	✓	✓	✓	✓	✓	✓	✓	✓
Line voltage 600 V, 60 Hz	V79	–	–	–	–	–	–	–	–	–	–	–	–
Line voltage 660 V, 60 Hz	V80	–	–	–	–	–	–	–	–	–	–	–	–
Special line voltage; please specify voltage	Y70 • and identification code	✓ ¹⁾	✓ ¹⁾	✓ ¹⁾	✓ ¹⁾	✓ ¹⁾	✓ ¹⁾	✓ ¹⁾	✓ ¹⁾	✓ ¹⁾	✓ ¹⁾	✓ ¹⁾	✓ ¹⁾
External auxiliary power supply													
Connection for 230 V 1 AC 50 Hz auxiliary voltage provided by customer	C36	✓	✓	✓	✓	✓	✓	✓	✓	✓	✓	✓	✓
Connection for 400 V 3 AC 50 Hz auxiliary voltage provided by customer	C38	✓	✓	✓	✓	✓	✓	✓	✓	✓	✓	✓	✓
Connection for 500 V 3 AC 50 Hz auxiliary voltage provided by customer	C43	✓	✓	✓	✓	✓	✓	✓	✓	✓	✓	✓	✓
Connection for 690 V 3 AC 50 Hz auxiliary voltage provided by customer	C48	✓	✓	✓	✓	✓	✓	✓	✓	✓	✓	✓	✓
Connection for other 3 AC voltage provided by customer; please specify voltage	Y36 • and identification code	✓	✓	✓	✓	✓	✓	✓	✓	✓	✓	✓	✓
External control voltage supply													
Connection for 24 V DC control voltage provided by customer	C55	✓	✓	✓	✓	✓	✓	✓	✓	✓	✓	✓	✓
Connection for 230 V 1 AC 50 Hz control voltage provided by customer, without UPS backup	C56	✓	✓	✓	✓	✓	✓	✓	✓	✓	✓	✓	✓
Connection for 230 V 1 AC 50 Hz control voltage provided by customer, with UPS backup	C57	✓	✓	✓	✓	✓	✓	✓	✓	✓	✓	✓	✓
Connection for different 1 AC control voltage (47 to 63 Hz) provided by customer; please specify voltage	Y55 • and identification code	✓	✓	✓	✓	✓	✓	✓	✓	✓	✓	✓	✓
RFI suppression filter													
RFI suppression filter, category C2 or C3 (class A)	L00	□	□	□	□	□	□	–	–	–	–	–	–
RFI suppression filter, category C1 (class B)	L02	✓	✓	✓	✓	✓	✓	–	–	–	–	–	–

For legends and footnotes, see Page 2/39.

SINAMICS G180

SINAMICS G180 compact units and SINAMICS G180 cabinet systems

SINAMICS G180 cabinet systems

Options

Option text	Additional ordering data -Z with order code and, if necessary, with plain text specification	SINAMICS G180 cabinet systems (compact units installed in a control cabinet)											
		400 V TN/TT system						500 V IT system					
		A	B	C	D	E	F	G	H	I	J	K	L
Line Harmonics Filter (LHF)													
Line Harmonics Filter for operation at 380 ... 415 V 3 AC, 50 Hz	L05	H81 ³⁾	H81 ³⁾	H82 ³⁾	H82 ³⁾	H81 ³⁾ + H91 ³⁾	H81 ³⁾ + H91 ³⁾	H81 ³⁾	H81 ³⁾	H82 ³⁾	H82 ³⁾	H81 ³⁾ + H91 ³⁾	H81 ³⁾ + H91 ³⁾
Line Harmonics Filter for operation at 440 ... 500 V 3 AC, 50 Hz	L06	H81 ³⁾	H81 ³⁾	H82 ³⁾	H82 ³⁾	H81 ³⁾ + H91 ³⁾	H81 ³⁾ + H91 ³⁾	H81 ³⁾	H81 ³⁾	H82 ³⁾	H82 ³⁾	H81 ³⁾ + H91 ³⁾	H81 ³⁾ + H91 ³⁾
Line Harmonics Filter for operation at 440 ... 480 V 3 AC, 60 Hz	L07	H81 ³⁾	H81 ³⁾	H82 ³⁾	H82 ³⁾	H81 ³⁾ + H91 ³⁾	H81 ³⁾ + H91 ³⁾	H81 ³⁾	H81 ³⁾	H82 ³⁾	H82 ³⁾	H81 ³⁾ + H91 ³⁾	H81 ³⁾ + H91 ³⁾
Output filter													
Strengthened dv/dt output filter for max. 250/300 m (type-dependent). Design for longer motor cables available on request	L10	✓	✓	✓	✓	✓	✓	□	□	□	□	□	□
Sine-wave filter integrated in control cabinet, suitable for motor frequencies of ≤ 75 Hz, voltage drop of approximately 5 % of line voltage	L17	✓	✓	✓	✓	✓	H81 ³⁾ + H91 ³⁾	✓	✓	✓	✓	✓	H81 ³⁾ + H91 ³⁾
Standard accessories packages													
Peripheral board 4 (G05) instead of peripheral board 2 (G03) (only in conjunction with package S01, S02, S03, S04, S08, S09, S11, S12)	G08	✓	✓	✓	✓	✓	✓	✓	✓	✓	✓	✓	✓
Accessories package S01 with main switch, line contactor, EMERGENCY OFF pushbutton and safety relay, board G03, local/remote switch	S01	✓	✓	✓	✓	✓	✓	✓	✓	✓	✓	✓	✓
Accessories package S02 with circuit breaker, line contactor, EMERGENCY OFF pushbutton and safety relay, board G03, local/remote switch	S02	✓	✓	✓	✓	✓	✓	✓	✓	✓	✓	✓	✓
Accessories package with main switch, line contactor, board G03, local/remote switch	S03	✓	✓	✓	✓	✓	✓	✓	✓	✓	✓	✓	✓
Accessories package with circuit breaker, line contactor, board G03, local/remote switch	S04	✓	✓	✓	✓	✓	✓	✓	✓	✓	✓	✓	✓
Accessories package with main switch, line contactor, ATEX certified PTC monitoring relay, RCU box connection	S06	✓	✓	✓	✓	✓	✓	✓	✓	✓	✓	✓	✓
Bypass for smooth line synchronization (soft start function) incl. line-side main switch and contactors at the converter output and in bypass	S08	✓	✓	✓	✓	H82 ³⁾	H83 ³⁾	✓	✓	✓	✓	H82 ³⁾	H83 ³⁾
Bypass for smooth line synchronization (soft start function) incl. line-side circuit breaker and contactors at the converter output and in bypass	S09	✓	✓	✓	✓	H82 ³⁾	H83 ³⁾	✓	✓	✓	✓	H82 ³⁾	H83 ³⁾
Accessories package S11 with line-side main switch, board G03, local/remote switch	S11	✓	✓	✓	✓	✓	✓	✓	✓	✓	✓	✓	✓
Accessories package S12 with line-side circuit breaker, board G03, local/remote switch	S12	✓	✓	✓	✓	✓	✓	✓	✓	✓	✓	✓	✓
Bypass with line-side main switch, contactors at converter output and in bypass, switchover between manual and automatic, local/remote switch	S21	✓	✓	✓	✓	H82 ³⁾	H83 ³⁾	✓	✓	✓	✓	H82 ³⁾	H83 ³⁾
Bypass with line-side circuit breaker, contactors at converter output and in bypass, switchover between manual and automatic, local/remote switch	S22	✓	✓	✓	✓	H82 ³⁾	H83 ³⁾	✓	✓	✓	✓	H82 ³⁾	H83 ³⁾
Bypass with line-side main switch, contactors at converter output and in bypass, EMERGENCY OFF safety relay, switchover between manual and automatic, local/remote switch	S23	✓	✓	✓	✓	H82 ³⁾	H83 ³⁾	✓	✓	✓	✓	H82 ³⁾	H83 ³⁾
Bypass with line-side circuit breaker, contactors at converter output and in bypass, EMERGENCY OFF safety relay, switchover between manual and automatic, local/remote switch	S24	✓	✓	✓	✓	H82 ³⁾	H83 ³⁾	✓	✓	✓	✓	H82 ³⁾	H83 ³⁾

For legends and footnotes, see Page 2/39.

Options

Option text	Additional ordering data -Z with order code and, if necessary, with plain text specification	SINAMICS G180 cabinet systems (compact units installed in a control cabinet)											
		400 V TN/TT system						500 V IT system					
		A	B	C	D	E	F	G	H	I	J	K	L
Standard accessories packages (continued)													
NAMUR accessories package with Test/Normal operation switch, option G05, terminal strip compliant with NAMUR NE37 (without main switch/main contactor)	S31	✓	✓	✓	✓	✓	✓	✓	✓	✓	✓	✓	✓
NAMUR accessories package with Test/Normal operation switch, main switch, line contactor, option G05, terminal strip compliant with NAMUR NE37	S32	✓	✓	✓	✓	✓	✓	✓	✓	✓	✓	✓	✓
Braking chopper													
Braking chopper integrated into converter (braking resistor is not included and must be ordered separately)	L72	□	✓	✓	✓	✓	✓	□	✓	✓	✓	✓	✓
ATEX certified PTC monitoring relay													
ATEX certified PTC monitoring relay without storage for motor temperature prewarning	L80	✓	✓	✓	✓	✓	✓	✓	✓	✓	✓	✓	✓
ATEX certified PTC monitoring relay with storage for motor temperature trip	L81	✓	✓	✓	✓	✓	✓	✓	✓	✓	✓	✓	✓
ATEX certified PTC monitoring relay without storage for transformer temperature prewarning	L82	✓	✓	✓	✓	✓	✓	✓	✓	✓	✓	✓	✓
ATEX certified PTC monitoring relay with storage for transformer temperature trip	L83	✓	✓	✓	✓	✓	✓	✓	✓	✓	✓	✓	✓
ATEX certified PTC monitoring relay for other PTC thermistor monitoring functions	Y80 • and identification code	✓	✓	✓	✓	✓	✓	✓	✓	✓	✓	✓	✓
Pt100 evaluation unit													
Pt100 evaluation unit for motor winding temperature, integrated in control cabinet for monitoring of 3 × Pt100 or 3 × KTY83/84 sensors	L90	✓	✓	✓	✓	✓	✓	✓	✓	✓	✓	✓	✓
Pt100 evaluation unit for motor bearing temperature, integrated in control cabinet for monitoring of 2 × Pt100 or 2 × KTY83/84 sensors	L91	✓	✓	✓	✓	✓	✓	✓	✓	✓	✓	✓	✓
Pt100 evaluation unit for motor winding temperature, integrated in cabinet for monitoring 3 × Pt100 sensors; plus an analog output 0 to 10 V or 0(4) to 20 mA connected to terminals for the hottest winding temperature	L92	✓	✓	✓	✓	✓	✓	✓	✓	✓	✓	✓	✓
Pt100 evaluation unit for motor bearing temperature, integrated in cabinet for monitoring 2 × Pt100 sensors or 2 × KTY83/84 sensors; plus two analog outputs 0 to 10 V or 0(4) to 20 mA connected to terminals for bearing temperature	L93	✓	✓	✓	✓	✓	✓	✓	✓	✓	✓	✓	✓
Pt100 evaluation unit for motor winding and bearing temperatures, integrated in cabinet for monitoring 6 × Pt100 sensors; plus two analog outputs 0 to 10 V or 0(4) to 20 mA connected to terminals for the hottest winding and bearing temperatures	L94	✓	✓	✓	✓	✓	✓	✓	✓	✓	✓	✓	✓
Pt100 evaluation unit for other temperature monitoring functions, integrated in cabinet for monitoring of 3 × Pt100 or 3 × KTY83/84 sensors	Y90 • and identification code	✓	✓	✓	✓	✓	✓	✓	✓	✓	✓	✓	✓
Pt100 evaluation unit for other temperature monitoring functions, integrated in cabinet for monitoring 6 × Pt100 sensors; plus two analog outputs 0 to 10 V or 0(4) to 20 mA connected to terminals	Y94 • and identification code	✓	✓	✓	✓	✓	✓	✓	✓	✓	✓	✓	✓
Degrees of protection													
Increased degree of protection IP41 for air-cooled cabinet units and systems	M41	✓	✓	✓	✓	✓	✓	✓	✓	✓	✓	✓	✓
Increased degree of protection IP43 for air-cooled cabinet units and systems	M43	✓	✓	✓	✓	✓	✓	✓	✓	✓	✓	✓	✓

For legends and footnotes, see Page 2/39.

SINAMICS G180

SINAMICS G180 compact units and SINAMICS G180 cabinet systems

SINAMICS G180 cabinet systems

Options

Option text	Additional ordering data -Z with order code and, if necessary, with plain text specification	SINAMICS G180 cabinet systems (compact units installed in a control cabinet)											
		400 V TN/TT system						500 V IT system					
		Version – see selection and ordering data											
		A	B	C	D	E	F	G	H	I	J	K	L
Degrees of protection (continued)													
Increased degree of protection IP54 for air-cooled cabinet units and systems; not suitable for outdoor applications	M54	✓	✓	✓	✓	✓	✓	✓	✓	✓	✓	✓	✓
Air flange for connection to customer's exhaust air systems (air outlet IP00)	M63	✓	✓	✓	✓	✓	✓	✓	✓	✓	✓	✓	✓
Cabinet options													
Control cabinet base, welded and suitable for use with transport rollers, in RAL 7022, h = 200 mm	M05	✓	✓	✓	✓	✓	✓	✓	✓	✓	✓	✓	✓
Control cabinet base, standard version in RAL 9005, h = 100 mm	M06	✓	✓	✓	✓	✓	✓	✓	✓	✓	✓	✓	✓
Control cabinet base, standard version in RAL 9005, h = 200 mm	M07	✓	✓	✓	✓	✓	✓	✓	✓	✓	✓	✓	✓
Cable entry from the top: Power cable	M13	✓ ²⁾	✓ ²⁾	✓ ²⁾	✓ ²⁾	✓ ²⁾	✓ ²⁾	✓ ²⁾	✓ ²⁾	✓ ²⁾	✓ ²⁾	✓ ²⁾	✓ ²⁾
Door opening angle 180°	M17	✓	✓	✓	✓	✓	✓	✓	✓	✓	✓	✓	✓
Window in door for viewing internal display	M19	✓	✓	✓	✓	✓	✓	✓	✓	✓	✓	✓	✓
Partitions between compact units for cabinet systems	M24	✓	✓	✓	✓	✓	✓	✓	✓	✓	✓	✓	✓
Door hinge on left	M28	✓	✓	✓	✓	✓	✓	✓	✓	✓	✓	✓	✓
Cable entry from the top: Control cables	M34	✓ ²⁾	✓ ²⁾	✓ ²⁾	✓ ²⁾	✓ ²⁾	✓ ²⁾	✓ ²⁾	✓ ²⁾	✓ ²⁾	✓ ²⁾	✓ ²⁾	✓ ²⁾
Comfort-grip handle with double-bit key lock	M38	✓	✓	✓	✓	✓	✓	✓	✓	✓	✓	✓	✓
Comfort-grip handle with integrated pushbutton	M39	✓	✓	✓	✓	✓	✓	✓	✓	✓	✓	✓	✓
Comfort-grip handle with cylinder lock	M40	✓	✓	✓	✓	✓	✓	✓	✓	✓	✓	✓	✓
Air supply via cable floor. No filter mats required in door	M59	✓	✓	✓	✓	✓	✓	✓	✓	✓	✓	✓	✓
Cable entry from the top: Motor cables	M78	✓ ²⁾	✓ ²⁾	✓ ²⁾	✓ ²⁾	✓ ²⁾	✓ ²⁾	✓ ²⁾	✓ ²⁾	✓ ²⁾	✓ ²⁾	✓ ²⁾	✓ ²⁾
Special control cabinet paint color: Please specify RAL	Y09 • and identification code	✓	✓	✓	✓	✓	✓	✓	✓	✓	✓	✓	✓
Window in door for viewing internal components	Y19 • and identification code	✓	✓	✓	✓	✓	✓	✓	✓	✓	✓	✓	✓
Control elements and display instruments in control cabinet door													
SENTRON PAC3220 power monitoring device (without current transformer)	G10	✓	✓	✓	✓	✓	✓	✓	✓	✓	✓	✓	✓
SENTRON PAC3220 power monitoring device (with current transformer)	G11	✓	✓	✓	✓	✓	✓	✓	✓	✓	✓	✓	✓
PROFIBUS expansion module for option G10 or G11 (SENTRON PAC3220 power monitoring device)	G12	✓	✓	✓	✓	✓	✓	✓	✓	✓	✓	✓	✓
External 4-line operator panel, supplied separately packed	K14	✓	✓	✓	✓	✓	✓	✓	✓	✓	✓	✓	✓
External 4-line operator panel integrated in control cabinet door	K15	✓	✓	✓	✓	✓	✓	✓	✓	✓	✓	✓	✓
Selector switch in form of key-operated switch	K37	✓	✓	✓	✓	✓	✓	✓	✓	✓	✓	✓	✓
Accessories													
Grounding socket outlet 230 V, 50 Hz, 10 A, in control cabinet with 30 mA ground-fault circuit interrupter, external incoming supply	L48	✓	✓	✓	✓	✓	✓	✓	✓	✓	✓	✓	✓
Socket outlet 230 V, 50 Hz, 1 A, in control cabinet with 30 mA ground-fault circuit interrupter, supplied internally	L49	✓	✓	✓	✓	✓	✓	✓	✓	✓	✓	✓	✓
Magnetically attached cabinet light and door contact switch	L50	✓	✓	✓	✓	✓	✓	✓	✓	✓	✓	✓	✓
Cabinet heater to protect against condensation and/or for operation with supply air temperature of -5 °C or below	L55	✓	✓	✓	✓	✓	✓	✓	✓	✓	✓	✓	✓
Controlled outgoing feeder for motor heater, 230 V 1 AC, max. 4 kW	N35	✓	✓	✓	✓	✓	✓	✓	✓	✓	✓	✓	✓

For legends and footnotes, see Page 2/39.

Options

Option text	Additional ordering data -Z with order code and, if necessary, with plain text specification	SINAMICS G180 cabinet systems (compact units installed in a control cabinet)											
		400 V TN/TT system						500 V IT system					
Version – see selection and ordering data													
		A	B	C	D	E	F	G	H	I	J	K	L
Accessories (continued)													
Controlled outgoing feeder for external motor fan, external fan voltage for 3 AC. Converter line voltage, max. 4 kW	N36	✓	✓	✓	✓	✓	✓	✓	✓	✓	✓	✓	✓
Undervoltage release for main switch or circuit breaker; specify coil voltage	Y11 • and identification code	–	–	–	✓	✓	✓	–	–	–	✓	✓	✓
Controlled outgoing feeder for auxiliary drive up to max. 4 kW; please specify type of drive, voltage, number of phases	Y98 • and identification code	✓ ¹⁾	✓ ¹⁾	✓ ¹⁾	✓ ¹⁾	✓ ¹⁾	✓ ¹⁾	✓ ¹⁾	✓ ¹⁾	✓ ¹⁾	✓ ¹⁾	✓ ¹⁾	✓ ¹⁾
Marking of cable cores and items of equipment													
Dual marking of items of equipment	M96	✓	✓	✓	✓	✓	✓	✓	✓	✓	✓	✓	✓
Cable marking	M94	✓	✓	✓	✓	✓	✓	✓	✓	✓	✓	✓	✓
Wiring options													
Cross-section of cables installed inside cabinet 1.5 mm ²	M20	✓	✓	✓	✓	✓	✓	✓	✓	✓	✓	✓	✓
Use of halogen-free cables inside cabinet	N50	✓	✓	✓	✓	✓	✓	✓	✓	✓	✓	✓	✓
Other options													
Board for mains supply backup	E85	x	x	x	x	x	x	x	x	x	x	x	x
DC link connected to terminals	N39	✓	✓	✓	✓	✓	✓	✓	✓	✓	✓	✓	✓
Peripheral boards													
Peripheral board 1	G02	✓	✓	✓	✓	✓	✓	✓	✓	✓	✓	✓	✓
Peripheral board 2	G03	✓	✓	✓	✓	✓	✓	✓	✓	✓	✓	✓	✓
Peripheral board 3	G04	✓	✓	✓	✓	✓	✓	✓	✓	✓	✓	✓	✓
Peripheral board 4	G05	✓	✓	✓	✓	✓	✓	✓	✓	✓	✓	✓	✓
Additional boards for bus connection													
Board for PROFIBUS DPV1	G01	✓	✓	✓	✓	✓	✓	✓	✓	✓	✓	✓	✓
Board for PROFINET CU	G06	✓	✓	✓	✓	✓	✓	✓	✓	✓	✓	✓	✓
Board for CANopen	G20	✓	✓	✓	✓	✓	✓	✓	✓	✓	✓	✓	✓
Board for Modbus RTU	G22	✓	✓	✓	✓	✓	✓	✓	✓	✓	✓	✓	✓
Board for Modbus TCP	G27	✓	✓	✓	✓	✓	✓	✓	✓	✓	✓	✓	✓
Accessories for IMS													
USB PROFIBUS interface (supplied separately packed)	G13	✓	✓	✓	✓	✓	✓	✓	✓	✓	✓	✓	✓
Ethernet-PROFIBUS gateway	G14	✓	✓	✓	✓	✓	✓	✓	✓	✓	✓	✓	✓
Ethernet-to-RS232/485/422 converter (supplied separately packed)	G15	✓	✓	✓	✓	✓	✓	✓	✓	✓	✓	✓	✓
USB cable A/B (supplied separately packed)	G16	✓	✓	✓	✓	✓	✓	✓	✓	✓	✓	✓	✓
USB connector on front of control cabinet door	G18	✓	✓	✓	✓	✓	✓	✓	✓	✓	✓	✓	✓
Extension of the liability for defects													
Extension of the liability for defects period by 12 months to a total of 24 months (2 years) after being delivered	Q80	✓	✓	✓	✓	✓	✓	✓	✓	✓	✓	✓	✓
Extension of the liability for defects period by 18 months to a total of 30 months (2½ years) after being delivered	Q81	✓	✓	✓	✓	✓	✓	✓	✓	✓	✓	✓	✓
Extension of the liability for defects period by 24 months to a total of 36 months (3 years) after being delivered	Q82	✓	✓	✓	✓	✓	✓	✓	✓	✓	✓	✓	✓
Extension of the liability for defects period by 30 months to a total of 42 months (3½ years) after being delivered	Q83	✓	✓	✓	✓	✓	✓	✓	✓	✓	✓	✓	✓
Extension of the liability for defects period by 36 months to a total of 48 months (4 years) after being delivered	Q84	✓	✓	✓	✓	✓	✓	✓	✓	✓	✓	✓	✓
Extension of the liability for defects period by 48 months to a total of 60 months (5 years) after being delivered	Q85	✓	✓	✓	✓	✓	✓	✓	✓	✓	✓	✓	✓

For legends and footnotes, see Page 2/39.

SINAMICS G180

SINAMICS G180 compact units and SINAMICS G180 cabinet systems

SINAMICS G180 cabinet systems

Options

Option text	Additional ordering data -Z with order code and, if necessary, with plain text specification	SINAMICS G180 cabinet systems (compact units installed in a control cabinet)											
		400 V TN/TT system						500 V IT system					
Version – see selection and ordering data		A	B	C	D	E	F	G	H	I	J	K	L
Label for plant identification													
Cabinet designation TAG/ITEM number according to ordering data	T01	✓	✓	✓	✓	✓	✓	✓	✓	✓	✓	✓	✓
Customized labels	Y33 • and identification code	✓	✓	✓	✓	✓	✓	✓	✓	✓	✓	✓	✓
Ambient temperature for air-cooled converters													
45 °C ambient temperature (with corresponding derating)	V61	✓	✓	✓	✓	✓	✓	✓	✓	✓	✓	✓	✓
50 °C ambient temperature (with corresponding derating)	V62	✓	✓	✓	✓	✓	✓	✓	✓	✓	✓	✓	✓
Installation altitude													
Installation altitude max. 1500 m above sea level (with corresponding derating)	V86	✓	✓	✓	✓	✓	✓	✓	✓	✓	✓	✓	✓
Installation altitude max. 2000 m above sea level (with corresponding derating)	V87	✓	✓	✓	✓	✓	✓	✓	✓	✓	✓	✓	✓
Installation altitude max. 2500 m above sea level (with corresponding derating)	V88	✓	✓	✓	✓	✓	✓	✓	✓	✓	✓	✓	✓
Installation altitude max. 3000 m above sea level (with corresponding derating)	V89	✓	✓	✓	✓	✓	✓	✓	✓	✓	✓	✓	✓
Acceptance tests for converters													
Routine test under no-load conditions with customer present	F71	✓	✓	✓	✓	✓	✓	✓	✓	✓	✓	✓	✓
Supplementary documentation													
Test sequence schedule	B48	✓	✓	✓	✓	✓	✓	✓	✓	✓	✓	✓	✓
Spare parts price list	B38	✓	✓	✓	✓	✓	✓	✓	✓	✓	✓	✓	✓
Production flowchart: Generated once	B43	✓	✓	✓	✓	✓	✓	✓	✓	✓	✓	✓	✓
Production flowchart: Generated once per month	B45	✓	✓	✓	✓	✓	✓	✓	✓	✓	✓	✓	✓
Converter display language													
Display language Norwegian/English	T23	✓	✓	✓	✓	✓	✓	✓	✓	✓	✓	✓	✓
Display language Swedish/English	T24	✓	✓	✓	✓	✓	✓	✓	✓	✓	✓	✓	✓
Display language Czech/English	T25	✓	✓	✓	✓	✓	✓	✓	✓	✓	✓	✓	✓
Display language Hungarian/English	T26	✓	✓	✓	✓	✓	✓	✓	✓	✓	✓	✓	✓
Display language French/English	T58	✓	✓	✓	✓	✓	✓	✓	✓	✓	✓	✓	✓

SINAMICS G180 compact units and SINAMICS G180 cabinet systems

SINAMICS G180 cabinet systems

Options

Option text	Additional ordering data -Z with order code and, if necessary, with plain text specification	SINAMICS G180 cabinet systems (compact units installed in a control cabinet)											
		400 V TN/TT system						500 V IT system					
Version – see selection and ordering data		A	B	C	D	E	F	G	H	I	J	K	L
Converter display language (continued)													
Display language Spanish/English	T60	✓	✓	✓	✓	✓	✓	✓	✓	✓	✓	✓	✓
Display language German/English	T74	✓	✓	✓	✓	✓	✓	✓	✓	✓	✓	✓	✓
Display language English/German	T76	✓	✓	✓	✓	✓	✓	✓	✓	✓	✓	✓	✓
Display language Portuguese/English	T82	✓	✓	✓	✓	✓	✓	✓	✓	✓	✓	✓	✓
Display language Russian/English	T85	✓	✓	✓	✓	✓	✓	✓	✓	✓	✓	✓	✓
Display language Polish/English	T86	✓	✓	✓	✓	✓	✓	✓	✓	✓	✓	✓	✓
Second display language other than English	Y14	✓	✓	✓	✓	✓	✓	✓	✓	✓	✓	✓	✓
Converter documentation													
Manual and set of diagrams in PDF format per e-mail, German/English	D01	□	□	□	□	□	□	□	□	□	□	□	□
Manual in PDF format, set of diagrams in DXF format per e-mail, German/English	D02	✓	✓	✓	✓	✓	✓	✓	✓	✓	✓	✓	✓
Language and manual													
Different language for manual	Y13 • and identification code	✓	✓	✓	✓	✓	✓	✓	✓	✓	✓	✓	✓
Certifications													
EAC certificate	U04	✓	✓	✓	✓	✓	✓	✓	✓	✓	✓	✓	✓
Engineering (for description, see Page 4/33)													
Mechanical system		✓	✓	✓	✓	✓	✓	✓	✓	✓	✓	✓	✓
Parameterization		✓	✓	✓	✓	✓	✓	✓	✓	✓	✓	✓	✓
Electrical (power output, control)		✓	✓	✓	✓	✓	✓	✓	✓	✓	✓	✓	✓
Extended overvoltage range		✓	✓	✓	✓	✓	✓	– ⁴⁾	– ⁴⁾	– ⁴⁾	– ⁴⁾	– ⁴⁾	– ⁴⁾
Test bay converter		✓	✓	✓	✓	✓	✓	✓	✓	✓	✓	✓	✓
Special tests		✓	✓	✓	✓	✓	✓	✓	✓	✓	✓	✓	✓
Special documentation		✓	✓	✓	✓	✓	✓	✓	✓	✓	✓	✓	✓
Special version		✓	✓	✓	✓	✓	✓	✓	✓	✓	✓	✓	✓

✓ Available

□ Standard version

– Not possible

× Not required

• This order code only determines the price of the version – additional plain text is required.

1) Voltage between 230 and 500 V.

2) Please ask your Siemens contact person for the exact cabinet dimensions.

3) Additional option included in the original option.

4) 690 V compact units + the next-higher rating must be selected for the "Extended overvoltage range" function.

SINAMICS G180

SINAMICS G180 compact units and SINAMICS G180 cabinet systems

SINAMICS G180 cabinet systems

Options

Option text	Additional ordering data -Z with order code and, if necessary, with plain text specification	SINAMICS G180 cabinet systems (compact units installed in a control cabinet)										
		690 V TN/TT system						690 V IT system				
Version – see selection and ordering data												
		M	N	O	P	Q	R	S	T	U	V	
Converter cabinet width												
406 mm	H80	✓	✓	–	–	–	✓	✓	–	–	–	
606 mm	H81	□	□	□	□	□	□	□	□	□	□	
806 mm	H82	✓	✓	✓	✓	✓	✓	✓	✓	✓	✓	
1006 mm	H83	✓	✓	✓	✓	✓	✓	✓	✓	✓	✓	
1206 mm	H84	✓	✓	✓	✓	✓	✓	✓	✓	✓	✓	
1406 mm	H85	✓	✓	✓	✓	✓	✓	✓	✓	✓	✓	
1606 mm	H86	✓	✓	✓	✓	✓	✓	✓	✓	✓	✓	
Additional cabinet												
400 mm	H90	✓	✓	✓	✓	✓	✓	✓	✓	✓	✓	
600 mm	H91	✓	✓	✓	✓	✓	✓	✓	✓	✓	✓	
800 mm	H92	✓	✓	✓	✓	✓	✓	✓	✓	✓	✓	
1000 mm	H93	✓	✓	✓	✓	✓	✓	✓	✓	✓	✓	
1200 mm	H94	✓	✓	✓	✓	✓	✓	✓	✓	✓	✓	
Line voltages												
Line voltage 380 V, 50 Hz	V70	✓	✓	✓	✓	✓	✓	✓	✓	✓	✓	
Line voltage 400 V, 50 Hz	V71	✓	✓	✓	✓	✓	✓	✓	✓	✓	✓	
Line voltage 415 V, 50 Hz	V72	✓	✓	✓	✓	✓	✓	✓	✓	✓	✓	
Line voltage 500 V, 50 Hz	V73	✓	✓	✓	✓	✓	✓	✓	✓	✓	✓	
Line voltage 660 V, 50 Hz	V74	✓	✓	✓	✓	✓	✓	✓	✓	✓	✓	
Line voltage 690 V, 50 Hz	V75	✓	✓	✓	✓	✓	✓	✓	✓	✓	✓	
Line voltage 440 V, 60 Hz	V76	✓	✓	✓	✓	✓	✓	✓	✓	✓	✓	
Line voltage 460 V, 60 Hz	V77	✓	✓	✓	✓	✓	✓	✓	✓	✓	✓	
Line voltage 480 V, 60 Hz	V78	✓	✓	✓	✓	✓	✓	✓	✓	✓	✓	
Line voltage 600 V, 60 Hz	V79	✓	✓	✓	✓	✓	✓	✓	✓	✓	✓	
Line voltage 660 V, 60 Hz	V80	✓	✓	✓	✓	✓	✓	✓	✓	✓	✓	
Special line voltage; please specify voltage	Y70 • and identification code	✓ ¹⁾	✓ ¹⁾	✓ ¹⁾	✓ ¹⁾	✓ ¹⁾	✓ ¹⁾	✓ ¹⁾	✓ ¹⁾	✓ ¹⁾	✓ ¹⁾	
External auxiliary power supply												
Connection for 230 V 1 AC 50 Hz auxiliary voltage provided by customer	C36	✓	✓	✓	✓	✓	✓	✓	✓	✓	✓	
Connection for 400 V 3 AC 50 Hz auxiliary voltage provided by customer	C38	✓	✓	✓	✓	✓	✓	✓	✓	✓	✓	
Connection for 500 V 3 AC 50 Hz auxiliary voltage provided by customer	C43	✓	✓	✓	✓	✓	✓	✓	✓	✓	✓	
Connection for 690 V 3 AC 50 Hz auxiliary voltage provided by customer	C48	✓	✓	✓	✓	✓	✓	✓	✓	✓	✓	
Connection for other 3 AC voltage provided by customer; please specify voltage	Y36 • and identification code	✓	✓	✓	✓	✓	✓	✓	✓	✓	✓	
External control voltage supply												
Connection for 24 V DC control voltage provided by customer	C55	✓	✓	✓	✓	✓	✓	✓	✓	✓	✓	
Connection for 230 V 1 AC 50 Hz control voltage provided by customer, without UPS backup	C56	✓	✓	✓	✓	✓	✓	✓	✓	✓	✓	
Connection for 230 V 1 AC 50 Hz control voltage provided by customer, with UPS backup	C57	✓	✓	✓	✓	✓	✓	✓	✓	✓	✓	
Connection for different 1 AC control voltage (47 to 63 Hz) provided by customer; please specify voltage	Y55 • and identification code	✓	✓	✓	✓	✓	✓	✓	✓	✓	✓	
RFI suppression filter												
RFI suppression filter, category C2 or C3 (class A)	L00	□	□	□	□	□	–	–	–	–	–	
RFI suppression filter, category C1 (class B)	L02	✓	✓	✓	✓	✓	–	–	–	–	–	

For legends and footnotes, see Page 2/46.

Options

Option text	Additional ordering data -Z with order code and, if necessary, with plain text specification	SINAMICS G180 cabinet systems (compact units installed in a control cabinet)										
		690 V TN/TT system						690 V IT system				
Version – see selection and ordering data												
		M	N	O	P	Q	R	S	T	U	V	
Output filter												
Strengthened dv/dt output filter for max. 250/300 m (type-dependent). Design for longer motor cables available on request	L10	✓	✓	✓	✓	H82 ³⁾	✓	✓	✓	✓	H82 ³⁾	
Sine-wave filter integrated in control cabinet, suitable for motor frequencies of ≤ 75 Hz, voltage drop of approximately 5 % of line voltage	L17	✓	✓	✓	✓	H81 ³⁾ + H92 ³⁾	✓	✓	✓	✓	H81 ³⁾ + H92 ³⁾	
Standard accessories packages												
Peripheral board 4 (G05) instead of peripheral board 2 (G03) (only in conjunction with package S01, S02, S03, S04, S08, S09, S11, S12)	G08	✓	✓	✓	✓	✓	✓	✓	✓	✓	✓	
Accessories package S01 with main switch, line contactor, EMERGENCY OFF pushbutton and safety relay, board G03, local/remote switch	S01	✓	✓	✓	✓	✓	✓	✓	✓	✓	✓	
Accessories package S02 with circuit breaker, line contactor, EMERGENCY OFF pushbutton and safety relay, board G03, local/remote switch	S02	✓	✓	✓	✓	✓	✓	✓	✓	✓	✓	
Accessories package with main switch, line contactor, board G03, local/remote switch	S03	✓	✓	✓	✓	✓	✓	✓	✓	✓	✓	
Accessories package with circuit breaker, line contactor, board G03, local/remote switch	S04	✓	✓	✓	✓	✓	✓	✓	✓	✓	✓	
Accessories package with main switch, line contactor, ATEX certified PTC monitoring relay, RCU box connection	S06	✓	✓	✓	✓	✓	✓	✓	✓	✓	✓	
Bypass for smooth line synchronization (soft start function) incl. line-side main switch and contactors at the converter output and in bypass	S08	✓	✓	✓	H82 ³⁾	H83 ³⁾	✓	✓	✓	H82 ³⁾	H83 ³⁾	
Bypass for smooth line synchronization (soft start function) incl. line-side circuit breaker and contactors at the converter output and in bypass	S09	✓	✓	✓	H82 ³⁾	H83 ³⁾	✓	✓	✓	H82 ³⁾	H83 ³⁾	
Accessories package S11 with line-side main switch, board G03, local/remote switch	S11	✓	✓	✓	✓	✓	✓	✓	✓	✓	✓	
Accessories package S12 with line-side circuit breaker, board G03, local/remote switch	S12	✓	✓	✓	✓	✓	✓	✓	✓	✓	✓	
Bypass with line-side main switch, contactors at converter output and in bypass, switchover between manual and automatic, local/remote switch	S21	✓	✓	✓	H82 ³⁾	H83 ³⁾	✓	✓	✓	H82 ³⁾	H83 ³⁾	
Bypass with line-side circuit breaker, contactors at converter output and in bypass, switchover between manual and automatic, local/remote switch	S22	✓	✓	✓	H82 ³⁾	H83 ³⁾	✓	✓	✓	H82 ³⁾	H83 ³⁾	
Bypass with line-side main switch, contactors at converter output and in bypass, EMERGENCY OFF safety relay, switchover between manual and automatic, local/remote switch	S23	✓	✓	✓	H82 ³⁾	H83 ³⁾	✓	✓	✓	H82 ³⁾	H83 ³⁾	
Bypass with line-side circuit breaker, contactors at converter output and in bypass, EMERGENCY OFF safety relay, switchover between manual and automatic, local/remote switch	S24	✓	✓	✓	H82 ³⁾	H83 ³⁾	✓	✓	✓	H82 ³⁾	H83 ³⁾	

For legends and footnotes, see Page 2/46.

SINAMICS G180

SINAMICS G180 compact units and SINAMICS G180 cabinet systems

SINAMICS G180 cabinet systems

Options

Option text	Additional ordering data -Z with order code and, if necessary, with plain text specification	SINAMICS G180 cabinet systems (compact units installed in a control cabinet)									
		690 V TN/TT system					690 V IT system				
Version – see selection and ordering data											
		M	N	O	P	Q	R	S	T	U	V
Standard accessories packages (continued)											
NAMUR accessories package with Test/ Normal operation switch, option G05, terminal strip compliant with NAMUR NE37 (without main switch/main contactor)	S31	✓	✓	✓	✓	✓	✓	✓	✓	✓	✓
NAMUR accessories package with Test/ Normal operation switch, main switch, line contactor, option G05, terminal strip compliant with NAMUR NE37	S32	✓	✓	✓	✓	✓	✓	✓	✓	✓	✓
Braking chopper											
Braking chopper integrated into converter (braking resistor is not included and must be ordered separately)	L72	✓	✓	✓	✓	✓	✓	✓	✓	✓	✓
ATEX certified PTC monitoring relay											
ATEX certified PTC monitoring relay without storage for motor temperature prewarning	L80	✓	✓	✓	✓	✓	✓	✓	✓	✓	✓
ATEX certified PTC monitoring relay with storage for motor temperature trip	L81	✓	✓	✓	✓	✓	✓	✓	✓	✓	✓
ATEX certified PTC monitoring relay without storage for transformer temperature prewarning	L82	✓	✓	✓	✓	✓	✓	✓	✓	✓	✓
ATEX certified PTC monitoring relay with storage for transformer temperature trip	L83	✓	✓	✓	✓	✓	✓	✓	✓	✓	✓
ATEX certified PTC monitoring relay for other PTC thermistor monitoring functions	Y80 • and identification code	✓	✓	✓	✓	✓	✓	✓	✓	✓	✓
Pt100 evaluation unit											
Pt100 evaluation unit for motor winding temperature, integrated in control cabinet for monitoring of 3 × Pt100 or 3 × KTY83/84 sensors	L90	✓	✓	✓	✓	✓	✓	✓	✓	✓	✓
Pt100 evaluation unit for motor bearing temperature, integrated in control cabinet for monitoring of 2 × Pt100 or 2 × KTY83/84 sensors	L91	✓	✓	✓	✓	✓	✓	✓	✓	✓	✓
Pt100 evaluation unit for motor winding temperature, integrated in cabinet for monitoring 3 × Pt100 sensors; plus an analog output 0 to 10 V or 0(4) to 20 mA connected to terminals for the hottest winding temperature	L92	✓	✓	✓	✓	✓	✓	✓	✓	✓	✓
Pt100 evaluation unit for motor bearing temperature, integrated in cabinet for monitoring 2 × Pt100 sensors or 2 × KTY83/84 sensors; plus two analog outputs 0 to 10 V or 0(4) to 20 mA connected to terminals for bearing temperature	L93	✓	✓	✓	✓	✓	✓	✓	✓	✓	✓
Pt100 evaluation unit for motor winding and bearing temperatures, integrated in cabinet for monitoring 6 × Pt100 sensors; plus two analog outputs 0 to 10 V or 0(4) to 20 mA connected to terminals for the hottest winding and bearing temperatures	L94	✓	✓	✓	✓	✓	✓	✓	✓	✓	✓
Pt100 evaluation unit for other temperature monitoring functions, integrated in cabinet for monitoring of 3 × Pt100 or 3 × KTY83/84 sensors	Y90 • and identification code	✓	✓	✓	✓	✓	✓	✓	✓	✓	✓
Pt100 evaluation unit for other temperature monitoring functions, integrated in cabinet for monitoring 6 × Pt100 sensors; plus two analog outputs 0 to 10 V or 0(4) to 20 mA connected to terminals	Y94 • and identification code	✓	✓	✓	✓	✓	✓	✓	✓	✓	✓

For legends and footnotes, see Page 2/46.

Options

Option text	Additional ordering data -Z with order code and, if necessary, with plain text specification	SINAMICS G180 cabinet systems (compact units installed in a control cabinet)										
		690 V TN/TT system						690 V IT system				
Version – see selection and ordering data												
		M	N	O	P	Q	R	S	T	U	V	
Degrees of protection												
Increased degree of protection IP41 for air-cooled cabinet units and systems	M41	✓	✓	✓	✓	✓	✓	✓	✓	✓	✓	
Increased degree of protection IP43 for air-cooled cabinet units and systems	M43	✓	✓	✓	✓	✓	✓	✓	✓	✓	✓	
Increased degree of protection IP54 for air-cooled cabinet units and systems; not suitable for outdoor applications	M54	✓	✓	✓	✓	✓	✓	✓	✓	✓	✓	
Air flange for connection to customer's exhaust air systems (air outlet IP00)	M63	✓	✓	✓	✓	✓	✓	✓	✓	✓	✓	
Cabinet options												
Control cabinet base, welded and suitable for use with transport rollers, in RAL 7022, h = 200 mm	M05	✓	✓	✓	✓	✓	✓	✓	✓	✓	✓	
Control cabinet base, standard version in RAL 9005, h = 100 mm	M06	✓	✓	✓	✓	✓	✓	✓	✓	✓	✓	
Control cabinet base, standard version in RAL 9005, h = 200 mm	M07	✓	✓	✓	✓	✓	✓	✓	✓	✓	✓	
Cable entry from the top: Power cable	M13	✓ ²⁾	✓ ²⁾	✓ ²⁾	✓ ²⁾	✓ ²⁾	✓ ²⁾	✓ ²⁾	✓ ²⁾	✓ ²⁾	✓ ²⁾	
Door opening angle 180°	M17	✓	✓	✓	✓	✓	✓	✓	✓	✓	✓	
Window in door for viewing internal display	M19	✓	✓	✓	✓	✓	✓	✓	✓	✓	✓	
Partitions between compact units for cabinet systems	M24	✓	✓	✓	✓	✓	✓	✓	✓	✓	✓	
Door hinge on left	M28	✓	✓	✓	✓	✓	✓	✓	✓	✓	✓	
Cable entry from the top: Control cables	M34	✓ ²⁾	✓ ²⁾	✓ ²⁾	✓ ²⁾	✓ ²⁾	✓ ²⁾	✓ ²⁾	✓ ²⁾	✓ ²⁾	✓ ²⁾	
Comfort-grip handle with double-bit key lock	M38	✓	✓	✓	✓	✓	✓	✓	✓	✓	✓	
Comfort-grip handle with integrated pushbutton	M39	✓	✓	✓	✓	✓	✓	✓	✓	✓	✓	
Comfort-grip handle with cylinder lock	M40	✓	✓	✓	✓	✓	✓	✓	✓	✓	✓	
Air supply via cable floor. No filter mats required in door	M59	✓	✓	✓	✓	✓	✓	✓	✓	✓	✓	
Cable entry from the top: Motor cables	M78	✓ ²⁾	✓ ²⁾	✓ ²⁾	✓ ²⁾	✓ ²⁾	✓ ²⁾	✓ ²⁾	✓ ²⁾	✓ ²⁾	✓ ²⁾	
Special control cabinet paint color: Please specify RAL	Y09 • and identification code	✓	✓	✓	✓	✓	✓	✓	✓	✓	✓	
Window in door for viewing internal components	Y19 • and identification code	✓	✓	✓	✓	✓	✓	✓	✓	✓	✓	
Control elements and display instruments in control cabinet door												
SENTRON PAC3220 power monitoring device (without current transformer)	G10	✓	✓	✓	✓	✓	✓	✓	✓	✓	✓	
SENTRON PAC3220 power monitoring device (with current transformer)	G11	✓	✓	✓	✓	✓	✓	✓	✓	✓	✓	
PROFIBUS expansion module for option G10 or G11 (SENTRON PAC3220 power monitoring device)	G12	✓	✓	✓	✓	✓	✓	✓	✓	✓	✓	
External 4-line operator panel, supplied separately packed	K14	✓	✓	✓	✓	✓	✓	✓	✓	✓	✓	
External 4-line operator panel integrated in control cabinet door	K15	✓	✓	✓	✓	✓	✓	✓	✓	✓	✓	
Selector switch in form of key-operated switch	K37	✓	✓	✓	✓	✓	✓	✓	✓	✓	✓	
Accessories												
Grounding socket outlet 230 V, 50 Hz, 10 A, in control cabinet with 30 mA ground-fault circuit interrupter, external incoming supply	L48	✓	✓	✓	✓	✓	✓	✓	✓	✓	✓	
Socket outlet 230 V, 50 Hz, 1 A, in control cabinet with 30 mA ground-fault circuit interrupter, supplied internally	L49	✓	✓	✓	✓	✓	✓	✓	✓	✓	✓	
Magnetically attached cabinet light and door contact switch	L50	✓	✓	✓	✓	✓	✓	✓	✓	✓	✓	

For legends and footnotes, see Page 2/46.

SINAMICS G180

SINAMICS G180 compact units and SINAMICS G180 cabinet systems

SINAMICS G180 cabinet systems

Options

Option text	Additional ordering data -Z with order code and, if necessary, with plain text specification	SINAMICS G180 cabinet systems (compact units installed in a control cabinet)										
		690 V TN/TT system						690 V IT system				
Version – see selection and ordering data												
		M	N	O	P	Q	R	S	T	U	V	
Accessories (continued)												
Cabinet heater to protect against condensation and/or for operation with supply air temperature of -5 °C or below	L55	✓	✓	✓	✓	✓	✓	✓	✓	✓	✓	
Controlled outgoing feeder for motor heater, 230 V 1 AC, max. 4 kW	N35	✓	✓	✓	✓	✓	✓	✓	✓	✓	✓	
Controlled outgoing feeder for external motor fan, external fan voltage for 3 AC. Converter line voltage, max. 4 kW	N36	✓	✓	✓	✓	✓	✓	✓	✓	✓	✓	
Undervoltage release for main switch or circuit breaker; specify coil voltage	Y11 • and identification code	–	–	–	✓	✓	–	–	–	✓	✓	
Controlled outgoing feeder for auxiliary drive up to max. 4 kW; please specify type of drive, voltage, number of phases	Y98 • and identification code	✓ ¹⁾	✓ ¹⁾	✓ ¹⁾	✓ ¹⁾	✓ ¹⁾	✓ ¹⁾	✓ ¹⁾	✓ ¹⁾	✓ ¹⁾	✓ ¹⁾	
Marking of cable cores and items of equipment												
Dual marking of items of equipment	M96	✓	✓	✓	✓	✓	✓	✓	✓	✓	✓	
Cable marking	M94	✓	✓	✓	✓	✓	✓	✓	✓	✓	✓	
Wiring options												
Cross-section of cables installed inside cabinet 1.5 mm ²	M20	✓	✓	✓	✓	✓	✓	✓	✓	✓	✓	
Use of halogen-free cables inside cabinet	N50	✓	✓	✓	✓	✓	✓	✓	✓	✓	✓	
Other options												
Board for mains supply backup	E85	□	□	✓	✓	✓	□	□	✓	✓	✓	
DC link connected to terminals	N39	□	□	□	□	□	□	□	□	□	□	
Peripheral boards												
Peripheral board 1	G02	✓	✓	✓	✓	✓	✓	✓	✓	✓	✓	
Peripheral board 2	G03	✓	✓	✓	✓	✓	✓	✓	✓	✓	✓	
Peripheral board 3	G04	✓	✓	✓	✓	✓	✓	✓	✓	✓	✓	
Peripheral board 4	G05	✓	✓	✓	✓	✓	✓	✓	✓	✓	✓	
Additional boards for bus connection												
Board for PROFIBUS DPV1	G01	✓	✓	✓	✓	✓	✓	✓	✓	✓	✓	
Board for PROFINET CU	G06	✓	✓	✓	✓	✓	✓	✓	✓	✓	✓	
Board for CANopen	G20	✓	✓	✓	✓	✓	✓	✓	✓	✓	✓	
Board for Modbus RTU	G22	✓	✓	✓	✓	✓	✓	✓	✓	✓	✓	
Board for Modbus TCP	G27	✓	✓	✓	✓	✓	✓	✓	✓	✓	✓	
Accessories for IMS												
USB PROFIBUS interface (supplied separately packed)	G13	✓	✓	✓	✓	✓	✓	✓	✓	✓	✓	
Ethernet-PROFIBUS gateway	G14	✓	✓	✓	✓	✓	✓	✓	✓	✓	✓	
Ethernet-to-RS232/485/422 converter (supplied separately packed)	G15	✓	✓	✓	✓	✓	✓	✓	✓	✓	✓	
USB cable A/B (supplied separately packed)	G16	✓	✓	✓	✓	✓	✓	✓	✓	✓	✓	
USB connector on front of control cabinet door	G18	✓	✓	✓	✓	✓	✓	✓	✓	✓	✓	
Extension of the liability for defects												
Extension of the liability for defects period by 12 months to a total of 24 months (2 years) after being delivered	Q80	✓	✓	✓	✓	✓	✓	✓	✓	✓	✓	
Extension of the liability for defects period by 18 months to a total of 30 months (2½ years) after being delivered	Q81	✓	✓	✓	✓	✓	✓	✓	✓	✓	✓	
Extension of the liability for defects period by 24 months to a total of 36 months (3 years) after being delivered	Q82	✓	✓	✓	✓	✓	✓	✓	✓	✓	✓	
Extension of the liability for defects period by 30 months to a total of 42 months (3½ years) after being delivered	Q83	✓	✓	✓	✓	✓	✓	✓	✓	✓	✓	

For legends and footnotes, see Page 2/46.

SINAMICS G180 compact units and SINAMICS G180 cabinet systems

SINAMICS G180 cabinet systems

Options

Option text	Additional ordering data -Z with order code and, if necessary, with plain text specification	SINAMICS G180 cabinet systems (compact units installed in a control cabinet)										
		690 V TN/TT system						690 V IT system				
Version – see selection and ordering data		M	N	O	P	Q	R	S	T	U	V	
Extension of the liability for defects (continued)												
Extension of the liability for defects period by 36 months to a total of 48 months (4 years) after being delivered	Q84	✓	✓	✓	✓	✓	✓	✓	✓	✓	✓	
Extension of the liability for defects period by 48 months to a total of 60 months (5 years) after being delivered	Q85	✓	✓	✓	✓	✓	✓	✓	✓	✓	✓	
Label for plant identification												
Cabinet designation TAG/ITEM number according to ordering data	T01	✓	✓	✓	✓	✓	✓	✓	✓	✓	✓	
Customized labels	Y33 • and identification code	✓	✓	✓	✓	✓	✓	✓	✓	✓	✓	
Ambient temperature for air-cooled converters												
45 °C ambient temperature (with corresponding derating)	V61	✓	✓	✓	✓	✓	✓	✓	✓	✓	✓	
50 °C ambient temperature (with corresponding derating)	V62	✓	✓	✓	✓	✓	✓	✓	✓	✓	✓	
Installation altitude												
Installation altitude max. 1500 m above sea level (with corresponding derating)	V86	✓	✓	✓	✓	✓	✓	✓	✓	✓	✓	
Installation altitude max. 2000 m above sea level (with corresponding derating)	V87	✓	✓	✓	✓	✓	✓	✓	✓	✓	✓	
Installation altitude max. 2500 m above sea level (with corresponding derating)	V88	✓	✓	✓	✓	✓	✓	✓	✓	✓	✓	
Installation altitude max. 3000 m above sea level (with corresponding derating)	V89	✓	✓	✓	✓	✓	✓	✓	✓	✓	✓	
Acceptance tests for converters												
Routine test under no-load conditions with customer present	F71	✓	✓	✓	✓	✓	✓	✓	✓	✓	✓	

2

SINAMICS G180

SINAMICS G180 compact units and SINAMICS G180 cabinet systems

SINAMICS G180 cabinet systems

Options

Option text	Additional ordering data -Z with order code and, if necessary, with plain text specification	SINAMICS G180 cabinet systems (compact units installed in a control cabinet)									
		690 V TN/TT system					690 V IT system				
Version – see selection and ordering data											
		M	N	O	P	Q	R	S	T	U	V
Supplementary documentation											
Test sequence schedule	B48	✓	✓	✓	✓	✓	✓	✓	✓	✓	✓
Spare parts price list	B38	✓	✓	✓	✓	✓	✓	✓	✓	✓	✓
Production flowchart: Generated once	B43	✓	✓	✓	✓	✓	✓	✓	✓	✓	✓
Production flowchart: Generated once per month	B45	✓	✓	✓	✓	✓	✓	✓	✓	✓	✓
Converter display language											
Display language Norwegian/English	T23	✓	✓	✓	✓	✓	✓	✓	✓	✓	✓
Display language Swedish/English	T24	✓	✓	✓	✓	✓	✓	✓	✓	✓	✓
Display language Czech/English	T25	✓	✓	✓	✓	✓	✓	✓	✓	✓	✓
Display language Hungarian/English	T26	✓	✓	✓	✓	✓	✓	✓	✓	✓	✓
Display language French/English	T58	✓	✓	✓	✓	✓	✓	✓	✓	✓	✓
Display language Spanish/English	T60	✓	✓	✓	✓	✓	✓	✓	✓	✓	✓
Display language German/English	T74	✓	✓	✓	✓	✓	✓	✓	✓	✓	✓
Display language English/German	T76	✓	✓	✓	✓	✓	✓	✓	✓	✓	✓
Display language Portuguese/English	T82	✓	✓	✓	✓	✓	✓	✓	✓	✓	✓
Display language Russian/English	T85	✓	✓	✓	✓	✓	✓	✓	✓	✓	✓
Display language Polish/English	T86	✓	✓	✓	✓	✓	✓	✓	✓	✓	✓
Second display language other than English	Y14	✓	✓	✓	✓	✓	✓	✓	✓	✓	✓
Converter documentation											
Manual and set of diagrams in PDF format per e-mail, German/English	D01	□	□	□	□	□	□	□	□	□	□
Manual in PDF format, set of diagrams in DXF format per e-mail, German/English	D02	✓	✓	✓	✓	✓	✓	✓	✓	✓	✓
Language of manual											
Different language for manual	Y13 • and identification code	✓	✓	✓	✓	✓	✓	✓	✓	✓	✓
Certifications											
EAC certificate	U04	✓	✓	✓	✓	✓	✓	✓	✓	✓	✓
Engineering (for description, see Page 4/33)											
Mechanical system		✓	✓	✓	✓	✓	✓	✓	✓	✓	✓
Parameterization		✓	✓	✓	✓	✓	✓	✓	✓	✓	✓
Electrical (power output, control)		✓	✓	✓	✓	✓	✓	✓	✓	✓	✓
Extended overvoltage range		✓	✓	✓	✓	✓	✓	✓	✓	✓	✓
Test bay converter		✓	✓	✓	✓	✓	✓	✓	✓	✓	✓
Special tests		✓	✓	✓	✓	✓	✓	✓	✓	✓	✓
Special documentation		✓	✓	✓	✓	✓	✓	✓	✓	✓	✓
Special version		✓	✓	✓	✓	✓	✓	✓	✓	✓	✓

✓ Available

□ Standard version

– Not possible

x Not required

• This order code only determines the price of the version – additional plain text is required.

1) Voltage between 230 and 500 V.

2) Please ask your Siemens contact person for the exact cabinet dimensions.

3) Additional option included in the original option.

Dimensional drawings

Standard cabinet size SL1 for cabinet systems (option H81)

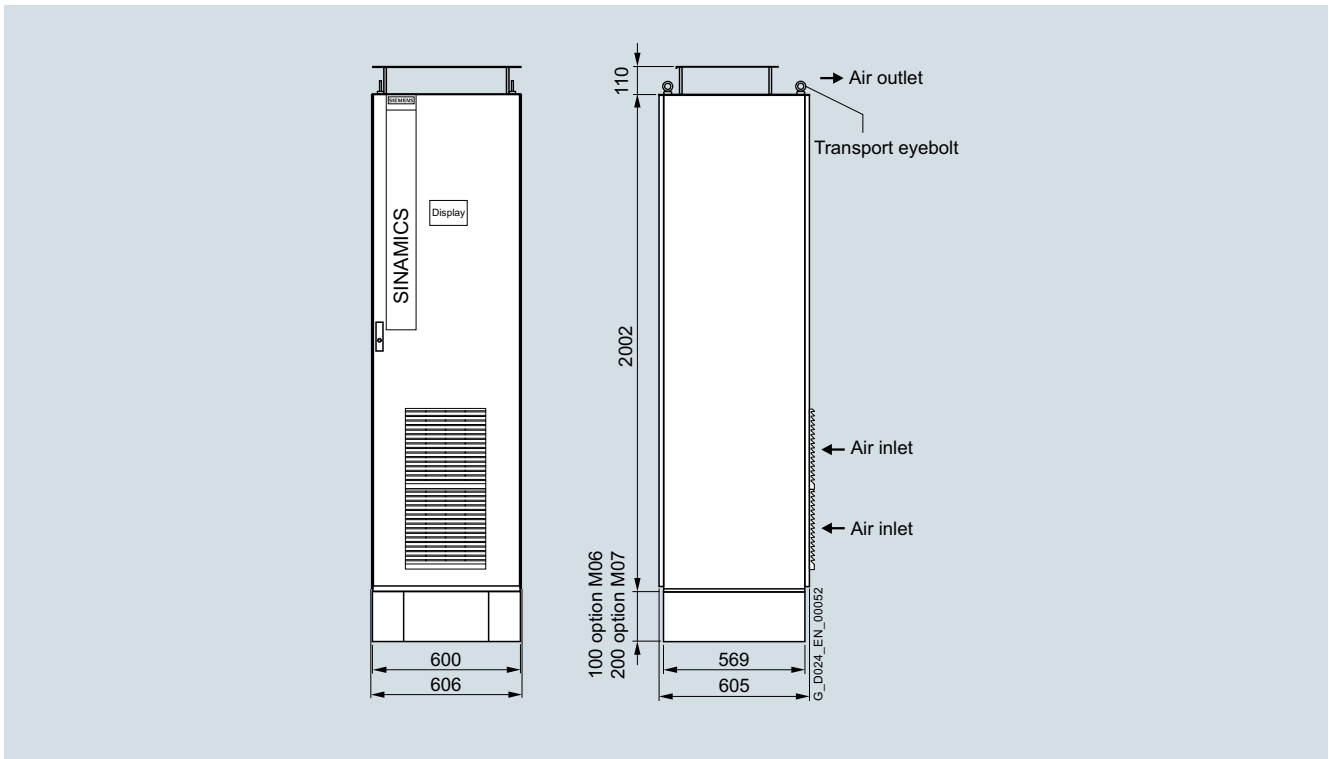

Dimensional drawing applies to standard cabinet systems (option H81) of the frame size SL1 with converter without options. The cabinet dimensions might change if options are selected.

SINAMICS G180

Notes

2

SINAMICS G180 cabinet units

3



3/2	SINAMICS G180 cabinet units air-cooled
3/2	<u>Overview</u>
3/2	<u>Design</u>
3/3	<u>Technical data</u>
3/3	Standards for cabinet units
3/4	General technical data
3/6	400 V, 6-pulse
3/8	400 V, 12-pulse
3/10	500 V, 6-pulse
3/12	500 V, 12-pulse
3/14	690 V, 6-pulse
3/17	690 V, 12-pulse
3/22	690 V, 18-pulse
3/24	690 V, 24-pulse
3/27	<u>Selection and ordering data</u>
3/27	400 V, 6-pulse
3/27	400 V, 12-pulse
3/28	500 V, 6-pulse
3/28	500 V, 12-pulse
3/29	690 V, 6-pulse
3/30	690 V, 12-pulse
3/30	690 V, 18-pulse
3/31	690 V, 24-pulse
3/32	Article number code
3/33	Number code for converter type
3/34	<u>Options</u>
3/41	<u>Dimensional drawings</u>
3/41	Frame size SL2
3/42	Frame size SL21
3/43	Frame size SL3
3/44	Frame size SL4
3/45	Frame size SL5
3/46	Frame size SL6
3/47	Frame size SL7
3/48	Frame size SL8
3/49	Frame size SL9
3/50	Frame size SL10
3/51	Frame size SL11
3/52	Frame size SL12

SINAMICS G180

SINAMICS G180 cabinet units

SINAMICS G180 cabinet units air-cooled

Overview



Example of SINAMICS G180 air-cooled converter cabinet unit

With its SINAMICS G180 cabinet units, Siemens is offering a drive system on which all line-side and motor-side components are integrated extremely compactly into a specially designed cabinet enclosure. This approach minimizes the effort and expense required to configure and install them. SINAMICS G180 cabinet units are available in air-cooled versions.

SINAMICS G180 converter cabinet units are available for the following voltages and power ratings:

Rated line voltage	Power
400 V 3 AC	200 ... 630 kW ¹⁾
500 V 3 AC	250 ... 800 kW ¹⁾
690 V 3 AC	250 ... 6700 kW

Global use

SINAMICS G180 converter cabinet units are manufactured in compliance with relevant international standards and regulations, and are therefore suitable for global use (see technical data).

Air-cooled converter cabinet units

Air-cooled converter cabinet units are equipped with an ingeniously designed, highly efficient air guidance system which is quiet in operation.

Design

- Control cabinet manufactured by Rittal TS8
- IP21 degree of protection, higher degree of protection available as option
- Cable clamping bar and shielding bus integrated
- Convenient terminal compartment for EMC-compliant cable connections to NAMUR NE 37
- Complete touch protection in accordance with Employers' Liability Association regulations (BGV A3)
- Cable entry from below

3

¹⁾ Higher outputs available on request.

Technical data

The most important directives and standards are listed below. These are used as basis for the SINAMICS G180 cabinet units and they must be carefully observed to achieve an EMC-compliant configuration that is safe both functionally and in operation.

Standards for cabinet units

European directives

2006/42/EC	Machinery Directive Directive of the European Parliament and Council of May 17, 2006, on machinery and amending Directive 95/16/EC (recast)
2014/35/EU	Low-Voltage Directive Directive of the European Parliament and Council of February 26, 2014 for the harmonization of the laws of the member states relating to the provision of electrical equipment designed for use within certain voltage limits on the market (recast)
2014/30/EU	EMC Directive Directive of the European Parliament and Council of February 26, 2014 for the harmonization of the laws of the member states relating to electromagnetic compatibility (recast)
2011/65/EU	RoHS Directive Directive of the European Parliament and of the Council of 8 June 2011 on the restriction of the use of certain hazardous substances in electrical and electronic equipment (recast)
(EU) 2019/1781	Regulation ecodesign requirements acc. to Ecodesign Directive Commission Regulation of October 1, 2019 on ecodesign requirements for electric motors and variable speed drives pursuant to Directive 2009/125/EC

International and European standards

EN ISO 13849-1	Safety of machinery – Safety-related parts of control systems; Part 1: General design principles (EN ISO 13849-1:2015)
EN 60146-1-1	Semiconductor converters – General requirements and line-commutated converters Part 1-1: Specification of basic requirements (EN 60146-1-1:2010)
EN 60204-1	Electrical equipment of machines, Part 1: General definitions (EN 60204-1:2007)
EN 60529	Degrees of protection provided by enclosures (IP code) (EN 60529:1991/A1:2000/A2:2013)
EN 61140	Protection against electric shock – Common aspects for installation and equipment (EN 61140-1-1:2016)
EN 61508-1	Functional safety of electrical/electronic/programmable electronic safety-related systems, Part 1: General requirements (EN 61508-1:2010)
EN 61800-2	Adjustable speed electrical power drive systems, Part 2: General requirements – Rating specifications for low-voltage adjustable frequency AC power drive systems (EN 61800-2:2015)
EN 61800-3	Adjustable speed electrical power drive systems, Part 3: EMC requirements and specific test methods (EN 61800-3:2004/A1:2012)
EN 61800-5-1	Adjustable-speed electrical power drive systems, Part 5-1: Safety requirements – Electrical, thermal and energy requirements (EN 61800-5-1:2007/A1:2017/A11:2021)
EN 61800-5-2	Adjustable-speed electrical power drive systems, Part 5-2: Safety requirements – Functional safety (IEC 61800-5-2:2017)

SINAMICS G180

SINAMICS G180 cabinet units

SINAMICS G180 cabinet units air-cooled

Technical data

General technical data

Electrical data			
	Line voltages	Type of supply system	Output ranges
	230 ... 400 ... 415 V 3 AC, -15/+10 % 230 ... 500 V 3 AC, -15/+10 % 400 ... 690 V 3 AC, -15/+10 %	TN/TT system TN/TT/IT system TN/TT/IT system	200 ... 630 kW (at 400 V) 250 ... 800 kW (at 500 V) 250 ... 6700 kW (at 690 V)
Line frequency	47 ... 63 Hz		
Output frequency	0 ... 120 (250) Hz		
Voltage rise in motor	Typ. 500 ... 1000 V/μs, but < 1500 V/μs		
Pulse number	6/12/18/24		
Typical line harmonics (<i>I</i>) in % of fundamental mode for the 5/7/11/13/17/19/23/25 harmonics, max. (6-pulse converter)	38/18/8/7/5/4/3/2		
Typical line harmonics (<i>I</i>) in % of fundamental mode for the 5/7/11/13/17/19/23/25 harmonics, max. (12-pulse converter)	1.5/1/6/4/0.5/0.2/2/2		
Typical line harmonics (<i>I</i>) in % of fundamental mode for the 5/7/11/13/17/19/23/25 harmonics, max. (18-pulse converter)	1/0.5/0.5/0.5/4/3.5/0.5/0.5		
Typical line harmonics (<i>I</i>) in % of fundamental mode for the 5/7/11/13/17/19/23/25 harmonics, max. (24-pulse converter)	1/0.5/0.5/0.5/0.5/0.2/2/2		
Typical line harmonics (<i>I</i>) in % of fundamental mode for the 5/7/11/13/17/19/23/25 harmonics max. with LHF filter	4.5/4.7/2.8/1.6/1.2/0.9/0.6/0.5		
Overvoltage category	III to EN 61800-5-1		
Short Circuit Current Rating (SCCR) in conjunction with the specified fuses or circuit breakers	20 times rated current, but at least 50 kA		
Control method	<ul style="list-style-type: none"> For motors: Field-oriented control (FOC) with sensor and approval for explosion-proof motors as well as vector control (SVC) with/without sensor (speed, process <i>speed</i> (<i>n</i>), torque, hoist¹⁾, line synchronization¹⁾) Motor-independent control of current or voltage (current, process <i>current</i> (<i>I</i>), voltage, process <i>voltage</i> (<i>U</i>)) 		
Fixed speeds	3 fixed speeds + 1 minimum speed, parameterizable		
Skipped speed ranges	2, parameterizable		
Setpoint resolution	13 bits digital with <i>n/f</i> setpoint, 12 bits digital with <i>U/I</i> torque setpoint, 9 bits + sign analog		
Braking operation	The oversaturation control system makes it possible to generate a braking torque of up to 50 % at low to mid-range speeds, and of up to 10 % at high speeds. If a higher braking torque is required, an optionally available braking module with appropriate braking resistor must be installed.		
Mechanical data			
Degree of protection	IP21 (higher degrees of protection optionally available)		
Protection class	I acc. to EN 61800-5-1		
Touch protection	EN 50274 / BGV A3		
Type of cooling	<ul style="list-style-type: none"> Air cooling AF acc. to EN 60146 		
Paint finish	RAL 7035; Rittal TS8 cabinet frame: With nano-ceramic and anodized coating, layer thickness approx. 10 to 20 μm; parts mounted on TS8 cabinet: With nano-ceramic and anodized coating, layer thickness approx. 10 to 20 μm, plus layer of hybrid polyester epoxy powder, thickness approx. 50 to 80 μm		
Cable entry	From below by means of profile clamp (from the top as option)		
Door hinge and opening angle	Right/130° or on both sides/130°		

¹⁾ On request

Technical data

General technical data (continued)

Ambient conditions ¹⁾	Storage ²⁾	Transport ²⁾	Operation
Ambient temperature	-25 ... <u>+55</u> °C Class 1K4 acc. to EN 60721-3-1: 1997	-25 ... +70 °C Down to <u>-40</u> °C for 24h Class 2K3 acc. to EN 60721-3-2: 1997	Air: 0 ... 40 °C/ (above +40 °C see derating data) Water: 1 °C ... 50 °C –
Relative humidity (condensation not permissible)	5 ... <u>95</u> % Class 1K3 acc. to EN 60721-3-1: 1997	5 ... 95 % Class 2K3 acc. to EN 60721-3-2: 1997	5 ... 95 % Class 3K3 acc. to EN 60721-3-3: 2002
Environmental class/harmful chemical substances	Class 1C2 acc. to EN 60721-3-1: 1997	Class 2C2 acc. to EN 60721-3-2: 1997	Class 3C2 acc. to EN 60721-3-3: 2002
Organic/biological influences	Class 1B1 acc. to EN 60721-3-1: 1997	Class 2B1 acc. to EN 60721-3-2: 1997	Class 3B1 acc. to EN 60721-3-3: 2002
Pollution degree	2 acc. to EN 61800-5-1		
Installation altitude	Up to 1000 m above sea level without derating, > 1000 m see derating data		
Mechanical stability ¹⁾	Storage ²⁾	Transport ²⁾	Operation
Vibratory load			
• Deflection	1.5 mm at <u>5</u> ... 9 Hz	3.5 mm at <u>5</u> ... 9 Hz	0.075 mm at 10 ... 57 Hz
• Acceleration	5 m/s ² at > 9 ... 200 Hz Class 1M2 to EN 60721-3-1: 1997	10 m/s ² at > 9 ... 200 Hz Class 2M2 to EN 60721-3-2: 1997	10 m/s ² at > 57 ... 150 Hz
Shock load			
• Acceleration	40 m/s ² at 22 ms Class 1M2 to EN 60721-3-1: 1997	100 m/s ² at 11 ms Class 2M2 to EN 60721-3-2: 1997	100 m/s ² at 11 ms Class 3M4 to EN 60721-3-3: 2002
Compliance with standards			
CE Label	Acc. to EMC Directive 2014/30/EU, Low-Voltage Directive 2014/35/EU and Ecodesign requirements of the EU Directive 2019/1781		
Radio interference suppression	Complies with EMC guidelines defined in EN 61800-3 thanks to line filter which is integrated as standard with grounded supply system: <ul style="list-style-type: none"> • Category C3 for cabinet units in TN/TT system of the second environment (industrial area) • Category C4 for cabinet units in IT system of the second environment (industrial area) 		

Deviations from the specified classes are underlined.

¹⁾ Higher standards on request

²⁾ In transport packaging

SINAMICS G180

SINAMICS G180 cabinet units

SINAMICS G180 cabinet units air-cooled

Technical data

400 V, 6-pulse

Line voltage, supply system type		400, 415 V 3 AC TT/TN				
SINAMICS G180 cabinet units		6SE0180-1BA33-7AA7	6SE0180-1BA34-6AA7	6SE0180-1BA36-3AA7	6SE0180-1BA37-3AA7	6SE0180-1BA38-8AA7
Converter type		2T3A-87401-200	2T3A-87401-250	2T3A-87401-315	2T3A-87401-400	2T3A-87401-500
Electrical data at motor end						
Type rating ¹⁾						
• at 50 Hz 400 V	kW	200	250	315	400	500
• at 50 Hz 400 V	hp	268	335	422	536	671
Output voltage ²⁾		V	0 ... 0.98 × V _{line}	0 ... 0.98 × V _{line}	0 ... 0.98 × V _{line}	0 ... 0.98 × V _{line}
Output current						
• Continuous current	A	380	460	630	740	910
• Short-time current (60 s every 10 minutes) max.	A	470	560	700	900	1110
Output power		kVA	263	319	436	630
Output frequency, max.		Hz	250	250	250	120
Rated clock cycle		kHz	3	3	3	2.4
adjustable from	kHz	2 ... 5	2 ... 5	2 ... 5	1.5 ... 3.7	1.5 ... 3.7
Power loss ³⁾		kW	5.6	6.42	8.4	11.9
Rated efficiency		%	97.4	97.6	97.5	97.2
Electrical data at line end						
Connected load		kVA	249	300	403	476
Rated input voltage		V	400	400	400	400
Input current						
• Continuous line current	A	360	433	582	687	871
• Short-time line current (60 s) max.	A	445	527	647	836	1062
Line fuse (provided by customer)		gL (A)	400	500	630	800
λ_{line}			0.931	0.928	0.943	0.942
Cos ϕ_{line}			1	1	1	1
Radio interference suppression acc. to EN 61800-3			C3 (class A filter)	C3 (class A filter)	C3 (class A filter)	C3 (class A filter)
Mechanical data						
Frame size (dimensional drawing classification)		SL2	SL2	SL2	SL21	SL3
Sound pressure level L _{pA} (1 m) at 50/60 Hz		dB	70	70	73	75
Standard converter dimensions						
• Width	mm	806	806	806	1206	1606
• Height ⁴⁾	mm	2112	2112	2112	2112	2112
• Depth	mm	605	605	605	605	605
Coolant requirements		m ³ /h	1900	1900	1900	2250
Weight, approx.		kg	490	510	530	780
General mechanical data						
Max. cable length between converter and motor with standard insulation (shielded)		m	300 ⁵⁾	300 ⁵⁾	300 ⁵⁾	300 ⁵⁾
Line/load connection						
L1, L2, L3/U2, V2, W2						
For connection cross-sections, see "Cable cross-sections and connections" in section "Configuring instructions"						

¹⁾ Rated power of a typical 2- to 6-pole standard motor.

²⁾ Typical output voltage dependent on filter and unit type.

³⁾ Maximum power loss with continuous motor current.

⁴⁾ With IP21 protective top cover (110 mm).

⁵⁾ Option L10 included (strengthened dv/dt filter; strengthened filter is integrated in unit).

Technical data

400 V, 6-pulse (continued)

Line voltage, supply system type	400, 415 V 3 AC TT/TN		
SINAMICS G180 cabinet units	6SE0180-1BA41-0AA7	6SE0180-1BA41-1AA7	
<i>Converter type</i>	2T3A-87401-560	2T3A-87401-630	
Electrical data at motor end			
Type rating¹⁾			
• at 50 Hz 400 V	kW	560	630
• at 50 Hz 400 V	hp	751	845
Output voltage²⁾	V	0 ... 0.98 × V _{line}	0 ... 0.98 × V _{line}
Output current			
• Continuous current	A	1020	1140
• Short-time current (60 s every 10 minutes) max.	A	1230	1370
Output power	kVA	707	790
Output frequency, max.	Hz	120	120
Rated clock cycle	kHz	2.4	2.4
adjustable from	kHz	1.5 ... 3.7	1.5 ... 3.7
Power loss³⁾	kW	16.7	18.1
Rated efficiency	%	97.2	97.3
Electrical data at line end			
Connected load	kVA	676	761
Rated input voltage	V	400	400
Input current			
• Continuous line current	A	975	1098
• Short-time line current (60 s) max.	A	1176	1320
Line fuse (provided by customer)	gL (A)	1000	1250
λ_{line}		0.947	0.95
cos φ_{line}		1	1
Radio interference suppression acc. to EN 61800-3		C3 (class A filter)	C3 (class A filter)
Mechanical data			
Frame size (dimensional drawing classification)	SL3	SL3	
Sound pressure level L_{pA} (1 m) at 50/60 Hz	dB	75	75
Standard converter dimensions			
• Width	mm	1606	1606
• Height ⁴⁾	mm	2112	2112
• Depth	mm	605	605
Coolant requirements	m ³ /h	3200	3800
Weight, approx.	kg	900	930
General mechanical data			
Max. cable length between converter and motor with standard insulation (shielded)	m	300 ⁵⁾	300 ⁵⁾
Line/load connection L1, L2, L3/U2, V2, W2 For connection cross-sections, see "Cable cross-sections and connections" in section "Configuring instructions"			

¹⁾ Rated power of a typical 2- to 6-pole standard motor.

²⁾ Typical output voltage dependent on filter and unit type.

³⁾ Maximum power loss with continuous motor current.

⁴⁾ With IP21 protective top cover (110 mm).

⁵⁾ Option L10 included (strengthened dv/dt filter; strengthened filter is integrated in unit).

SINAMICS G180

SINAMICS G180 cabinet units

SINAMICS G180 cabinet units air-cooled

Technical data

400 V, 12-pulse

Line voltage, supply system type		400, 415 V 3 AC IT				
SINAMICS G180 cabinet units		6SE0180-2BA33-7AA7	6SE0180-2BA34-6AA7	6SE0180-2BA36-3AA7	6SE0180-2BA37-3AA7	6SE0180-2BA38-8AA7
Converter type		2T3F-87401-200	2T3F-87401-250	2T3F-87401-315	2T3F-87401-400	2T3F-87401-500
Electrical data at motor end						
Type rating ¹⁾						
• at 50 Hz 400 V	kW	200	250	315	400	500
• at 50 Hz 400 V	hp	268	335	422	536	671
Output voltage ²⁾		V	0 ... 0.98 × V _{line}	0 ... 0.98 × V _{line}	0 ... 0.98 × V _{line}	0 ... 0.98 × V _{line}
Output current						
• Continuous current	A	380	460	630	740	910
• Short-time current (60 s every 10 minutes) max.	A	470	560	700	900	1110
Output power		kVA	263	319	436	630
Output frequency, max.		Hz	250	250	250	120
Rated clock cycle		kHz	3	3	3	2.4
adjustable from	kHz	2 ... 5	2 ... 5	2 ... 5	1.5 ... 3.7	1.5 ... 3.7
Power loss ³⁾		kW	5.6	6.42	8.4	11.9
Rated efficiency		%	97.4	97.6	97.5	97.2
Electrical data at line end						
Connected load		kVA	249	301	405	477
Rated input voltage		V	2 × 400	2 × 400	2 × 400	2 × 400
Input current						
• Continuous line current	A	2 × 180	2 × 217	2 × 292	2 × 344	2 × 436
• Short-time line current (60 s) max.	A	2 × 223	2 × 264	2 × 324	2 × 418	2 × 532
Line fuse (provided by customer)		gL (A)	200	250	400	400
λ_{line}			0.994	0.994	0.994	0.996
Cos ϕ_{line}			1	1	1	1
Radio interference suppression acc. to EN 61800-3			C3 (class A filter)	C3 (class A filter)	C3 (class A filter)	C3 (class A filter)
Mechanical data						
Frame size (dimensional drawing classification)		SL5	SL5	SL5	SL5	SL6
Sound pressure level L _{pA} (1 m) at 50/60 Hz		dB	70	70	73	75
Standard converter dimensions						
• Width	mm	1406	1406	1406	1406	1806
• Height ⁴⁾	mm	2112	2112	2112	2112	2112
• Depth	mm	605	605	605	605	605
Coolant requirements		m ³ /h	1900	1900	1900	2250
Weight, approx.		kg	690	710	730	810
General mechanical data						
Max. cable length between converter and motor with standard insulation (shielded)		m	300 ⁵⁾	300 ⁵⁾	300 ⁵⁾	300 ⁵⁾
Line/load connection						
L1, L2, L3/U2, V2, W2						
For connection cross-sections, see "Cable cross-sections and connections" in section "Configuring instructions"						

¹⁾ Rated power of a typical 2- to 6-pole standard motor.

²⁾ Typical output voltage dependent on filter and unit type.

³⁾ Maximum power loss with continuous motor current.

⁴⁾ With IP21 protective top cover (110 mm).

⁵⁾ Option L10 included (strengthened dv/dt filter; strengthened filter is integrated in unit).

Technical data

400 V, 12-pulse (continued)

Line voltage, supply system type	400, 415 V 3 AC IT		
SINAMICS G180 cabinet units	6SE0180-2BA41-0AA7 6SE0180-2BA41-1AA7		
<i>Converter type</i>	2T3F-87401-560 2T3F-87401-630		
Electrical data at motor end			
Type rating¹⁾			
• at 50 Hz 400 V	kW	560	630
• at 50 Hz 400 V	hp	751	845
Output voltage²⁾	V	0 ... 0.98 × V _{line}	0 ... 0.98 × V _{line}
Output current			
• Continuous current	A	1020	1140
• Short-time current (60 s every 10 minutes) max.	A	1230	1370
Output power	kVA	707	790
Output frequency, max.	Hz	120	120
Rated clock cycle	kHz	2.4	2.4
adjustable from	kHz	1.5 ... 3.7	1.5 ... 3.7
Power loss³⁾	kW	16.7	18.1
Rated efficiency	%	97.2	97.3
Electrical data at line end			
Connected load	kVA	676	762
Rated input voltage	V	2 × 400	2 × 400
Input current			
• Continuous line current	A	2 × 488	2 × 550
• Short-time line current (60 s) max.	A	2 × 588	2 × 661
Line fuse (provided by customer)	gL (A)	630	630
λ_{line}		0.996	0.997
cos φ_{line}		1	1
Radio interference suppression acc. to EN 61800-3		C4	C4
Mechanical data			
Frame size (dimensional drawing classification)	SL6	SL6	
Sound pressure level L_{pA} (1 m) at 50/60 Hz	dB	75	75
Standard converter dimensions			
• Width	mm	1806	1806
• Height ⁴⁾	mm	2112	2112
• Depth	mm	605	605
Coolant requirements	m ³ /h	3200	3800
Weight, approx.	kg	930	960
General mechanical data			
Max. cable length between converter and motor with standard insulation (shielded)	m	300 ⁵⁾	300 ⁵⁾
Line/load connection L1, L2, L3/U2, V2, W2 For connection cross-sections, see "Cable cross-sections and connections" in section "Configuring instructions"			

¹⁾ Rated power of a typical 2- to 6-pole standard motor.

²⁾ Typical output voltage dependent on filter and unit type.

³⁾ Maximum power loss with continuous motor current.

⁴⁾ With IP21 protective top cover (110 mm).

⁵⁾ Option L10 included (strengthened dv/dt filter; strengthened filter is integrated in unit).

SINAMICS G180

SINAMICS G180 cabinet units

SINAMICS G180 cabinet units air-cooled

Technical data

500 V, 6-pulse

Line voltage, supply system type SINAMICS G180 cabinet units <i>Converter type</i>		400, 415, 460, 500 V 3 AC IT/TT/TN				
		6SE0180- 1BD33-7AA7 <i>2T3A-87501-250</i>	6SE0180- 1BD34-6AA7 <i>2T3A-87501-315</i>	6SE0180- 1BD36-3AA7 <i>2T3A-87501-400</i>	6SE0180- 1BD37-3AA7 <i>2T3A-87501-500</i>	6SE0180- 1BD38-2AA7 <i>2T3A-87501-560</i>
Electrical data at motor end						
Type rating¹⁾						
• at 50 Hz 500 V	kW	250	315	400	500	560
• at 60 Hz 460 V	hp	309	389	494	617	691
Output voltage²⁾	V	0 ... 0.98 × V _{line}				
Output current						
• Continuous current	A	370	460	640	730	820
• Short-time current (60 s every 10 minutes) max.	A	450	560	700	900	980
Output power	kVA	320	398	554	632	710
Output frequency, max.	Hz	250	250	250	120	120
Rated clock cycle	kHz	3	3	2.4	2.4	2.4
adjustable from	kHz	2 ... 5	2 ... 5	1.5 ... 3.7	1.5 ... 3.7	1.5 ... 3.7
Power loss³⁾	kW	6.15	7.39	9.37	12.8	13.7
Rated efficiency	%	97.7	97.8	97.8	97.6	97.7
Electrical data at line end						
Connected load	kVA	303	378	515	606	678
Rated input voltage	V	500	500	500	500	500
Input current						
• Continuous line current	A	350	437	595	700	783
• Short-time line current (60 s) max.	A	426	532	651	863	936
Line fuse (provided by customer)	gL (A)	400	500	630	800	800
λ_{line}		0.918	0.916	0.936	0.942	0.944
cos ϕ_{line}		1	1	1	1	1
Radio interference suppression acc. to EN 61800-3⁴⁾		C3 (class A filter)	C3 (class A filter)	C3 (class A filter)	C3 (class A filter)	C3 (class A filter)
Mechanical data						
Frame size (dimensional drawing classification)		SL2	SL2	SL2	SL21	SL3
Sound pressure level L_{pA} (1 m) at 50/60 Hz	dB	70	73	73	75	75
Standard converter dimensions						
• Width	mm	806	806	806	1206	1606
• Height ⁵⁾	mm	2112	2112	2112	2112	2112
• Depth	mm	605	605	605	605	605
Coolant requirements	m ³ /h	1900	1900	1900	2250	3200
Weight, approx.	kg	490	510	530	780	890
General mechanical data						
Max. cable length between converter and motor with standard insulation (shielded)	m	250 ⁶⁾	250 ⁶⁾	250 ⁶⁾	250 ⁶⁾	250 ⁶⁾
Line/load connection L1, L2, L3/U2, V2, W2 For connection cross-sections, see "Cable cross-sections and connections" in section "Configuring instructions"						

¹⁾ Rated power of a typical 2- to 6-pole standard motor.

²⁾ Typical output voltage dependent on filter and unit type.

³⁾ Maximum power loss with continuous motor current.

⁴⁾ EMC filter not required for IT system, in which case RI suppression category C4.

⁵⁾ With IP21 protective top cover (110 mm).

⁶⁾ Option L10 included (strengthened dv/dt filter; strengthened filter is integrated in unit).

Technical data
500 V, 6-pulse (continued)

Line voltage, supply system type SINAMICS G180 cabinet units Converter type		400, 415, 460, 500 V 3 AC IT/TT/TN	6SE0180-1BD38-8AA7 2T3A-87501-630	6SE0180-1BD41-0AA7 2T3A-87501-710	6SE0180-1BD41-1AA7 2T3A-87501-800
Electrical data at motor end					
Type rating¹⁾					
• at 50 Hz 500 V	kW	630	710	800	
• at 60 Hz 460 V	hp	777	876	987	
Output voltage²⁾	V	0 ... 0.98 × V _{line}	0 ... 0.98 × V _{line}	0 ... 0.98 × V _{line}	
Output current					
• Continuous current	A	920	1030	1150	
• Short-time current (60 s every 10 minutes) max.	A	1100	1230	1380	
Output power	kVA	797	892	996	
Output frequency, max.	Hz	120	120	120	
Rated clock cycle	kHz	2.4	2.4	2.4	
adjustable from	kHz	1.5 ... 3.7	1.5 ... 3.7	1.5 ... 3.7	
Power loss³⁾	kW	15.4	18.1	20.3	
Rated efficiency	%	97.7	97.6	97.6	
Electrical data at line end					
Connected load	kVA	767	848	944	
Rated input voltage	V	500	500	500	
Input current					
• Continuous line current	A	886	979	1090	
• Short-time line current (60 s) max.	A	1059	1169	1308	
Line fuse (provided by customer)	gL (A)	900	1000	1250	
λ_{line}		0.946	0.948	0.95	
$\cos \varphi_{\text{line}}$		1	1	1	
Radio interference suppression acc. to EN 61800-3⁴⁾		C3 (class A filter)	C3 (class A filter)	C3 (class A filter)	
Mechanical data					
Frame size (dimensional drawing classification)	SL3	SL3	SL3	SL3	
Sound pressure level L_{pA} (1 m) at 50/60 Hz	dB	75	75	75	
Standard converter dimensions					
• Width	mm	1606	1606	1606	
• Height ⁵⁾	mm	2112	2112	2112	
• Depth	mm	605	605	605	
Coolant requirements	m ³ /h	3800	3200	3800	
Weight, approx.	kg	900	930	980	
General mechanical data					
Max. cable length between converter and motor with standard insulation (shielded)	m	250 ⁶⁾	250 ⁶⁾	250 ⁶⁾	
Line/load connection L1, L2, L3/U2, V2, W2 For connection cross-sections, see "Cable cross-sections and connections" in section "Configuring instructions"					

¹⁾ Rated power of a typical 2- to 6-pole standard motor.

²⁾ Typical output voltage dependent on filter and unit type.

³⁾ Maximum power loss with continuous motor current.

⁴⁾ EMC filter not required for IT system, in which case RI suppression category C4.

⁵⁾ With IP21 protective top cover (110 mm).

⁶⁾ Option L10 included (strengthened dv/dt filter; strengthened filter is integrated in unit).

SINAMICS G180

SINAMICS G180 cabinet units

SINAMICS G180 cabinet units air-cooled

Technical data

500 V, 12-pulse

Line voltage, supply system type		2 × 400, 415, 460, 500 V 3 AC IT				
SINAMICS G180 cabinet units		6SE0180-2BD33-7AA7	6SE0180-2BD34-6AA7	6SE0180-2BD36-3AA7	6SE0180-2BD37-3AA7	6SE0180-2BD38-2AA7
Converter type		2T3F-87501-250	2T3F-87501-315	2T3F-87501-400	2T3F-87501-500	2T3F-87501-560
Electrical data at motor end						
Type rating ¹⁾						
• at 50 Hz 500 V	kW	250	315	400	500	560
• at 60 Hz 460 V	hp	309	389	494	617	691
Output voltage ²⁾		V	0 ... 0.98 × V _{line}	0 ... 0.98 × V _{line}	0 ... 0.98 × V _{line}	0 ... 0.98 × V _{line}
Output current						
• Continuous current	A	370	460	640	730	820
• Short-time current (60 s every 10 minutes) max.	A	450	560	700	900	980
Output power		kVA	320	398	554	632
Output frequency, max.		Hz	250	250	250	120
Rated clock cycle		kHz	3	3	2.4	2.4
adjustable from	kHz	2 ... 5	2 ... 5	1.5 ... 3.7	1.5 ... 3.7	1.5 ... 3.7
Power loss ³⁾		kW	6.15	7.39	9.37	12.8
Rated efficiency		%	97.7	97.8	97.8	97.6
Electrical data at line end						
Connected load		kVA	303	378	516	606
Rated input voltage		V	2 × 500	2 × 500	2 × 500	2 × 500
Input current						
• Continuous line current	A	2 × 175	2 × 218	2 × 298	2 × 350	2 × 391
• Short-time line current (60 s) max.	A	2 × 213	2 × 265	2 × 326	2 × 432	2 × 467
Line fuse (provided by customer)		gL (A)	200	250	400	400
λ_{line}			0.994	0.994	0.994	0.996
Cos ϕ_{line}			1	1	1	1
Radio interference suppression acc. to EN 61800-3			C4	C4	C4	C4
Mechanical data						
Frame size (dimensional drawing classification)		SL5	SL5	SL5	SL5	SL6
Sound pressure level L _{pA} (1 m) at 50/60 Hz		dB	70	73	73	75
Standard converter dimensions						
• Width	mm	1406	1406	1406	1406	1806
• Height ⁴⁾	mm	2112	2112	2112	2112	2112
• Depth	mm	605	605	605	605	605
Coolant requirements		m ³ /h	1900	1900	1900	2250
Weight, approx.		kg	690	710	730	810
General mechanical data						
Max. cable length between converter and motor with standard insulation (shielded)		m	250 ⁵⁾	250 ⁵⁾	250 ⁵⁾	250 ⁵⁾
Line/load connection						
L1, L2, L3/U2, V2, W2						
For connection cross-sections, see "Cable cross-sections and connections" in section "Configuring instructions"						

¹⁾ Rated power of a typical 2- to 6-pole standard motor.

²⁾ Typical output voltage dependent on filter and unit type.

³⁾ Maximum power loss with continuous motor current.

⁴⁾ With IP21 protective top cover (110 mm).

⁵⁾ Option L10 included (strengthened dv/dt filter; strengthened filter is integrated in unit).

Technical data
500 V, 12-pulse (continued)

Line voltage, supply system type		2 × 400, 415, 460, 500 V 3 AC IT		
SINAMICS G180 cabinet units		6SE0180-2BD38-8AA7	6SE0180-2BD41-0AA7	6SE0180-2BD41-1AA7
<i>Converter type</i>		2T3F-87501-630	2T3F-87501-710	2T3F-87501-800
Electrical data at motor end				
Type rating¹⁾				
• at 50 Hz 500 V	kW	630	710	800
• at 60 Hz 460 V	hp	777	876	987
Output voltage²⁾	V	0 ... 0.98 × V _{line}	0 ... 0.98 × V _{line}	0 ... 0.98 × V _{line}
Output current				
• Continuous current	A	920	1030	1150
• Short-time current (60 s every 10 minutes) max.	A	1100	1230	1380
Output power	kVA	797	892	996
Output frequency, max.	Hz	120	120	120
Rated clock cycle	kHz	2.4	2.4	2.4
adjustable from	kHz	1.5 ... 3.7	1.5 ... 3.7	1.5 ... 3.7
Power loss³⁾	kW	15.4	18.1	20.3
Rated efficiency	%	97.7	97.6	97.6
Electrical data at line end				
Connected load	kVA	767	849	944
Rated input voltage	V	2 × 500	2 × 500	2 × 500
Input current				
• Continuous line current	A	2 × 443	2 × 490	2 × 545
• Short-time line current (60 s) max.	A	2 × 530	2 × 585	2 × 654
Line fuse (provided by customer)	gL (A)	500	630	630
λ_{line}		0.996	0.996	0.997
cos ϕ_{line}		1	1	1
Radio interference suppression acc. to EN 61800-3		C4	C4	C4
Mechanical data				
Frame size (dimensional drawing classification)		SL6	SL6	SL6
Sound pressure level L_{pA} (1 m) at 50/60 Hz	dB	75	75	75
Standard converter dimensions				
• Width	mm	1806	1806	1806
• Height ⁴⁾	mm	2112	2112	2112
• Depth	mm	605	605	605
Coolant requirements	m ³ /h	3800	3200	3800
Weight, approx.	kg	930	960	1010
General mechanical data				
Max. cable length between converter and motor with standard insulation (shielded)	m	250 ⁵⁾	250 ⁵⁾	250 ⁵⁾
Line/load connection L1, L2, L3/U2, V2, W2 For connection cross-sections, see "Cable cross-sections and connections" in section "Configuring instructions"				

¹⁾ Rated power of a typical 2- to 6-pole standard motor.

²⁾ Typical output voltage dependent on filter and unit type.

³⁾ Maximum power loss with continuous motor current.

⁴⁾ With IP21 protective top cover (110 mm).

⁵⁾ Option L10 included (strengthened dv/dt filter; strengthened filter is integrated in unit).

SINAMICS G180

SINAMICS G180 cabinet units

SINAMICS G180 cabinet units air-cooled

Technical data

690 V, 6-pulse

Line voltage, supply system type		400, 415, 460, 500, 575, 690 V 3 AC TT/TN or IT				
SINAMICS G180 cabinet units		6SE0180-1B33-2AA7	6SE0180-1B33-6AA7	6SE0180-1B34-2AA7	6SE0180-1B35-2AA7	6SE0180-1B35-7AA7
Converter type		2T3A-87601-250	2T3A-87601-315	2T3A-87601-400	2T3A-87601-500	2T3A-87601-560
Electrical data at motor end						
Type rating ¹⁾						
• at 50 Hz 690 V	kW	250	315	400	500	560
• at 60 Hz 575 V	hp	279	352	447	559	626
Output voltage ²⁾		V	0 ... 0.98 × V _{line}	0 ... 0.98 × V _{line}	0 ... 0.98 × V _{line}	0 ... 0.98 × V _{line}
Output current						
• Continuous current	A	270	340	440	530	590
• Short-time current (60 s every 10 minutes) max.	A	320	410	510	640	710
Output power		kVA	323	406	526	633
Output frequency, max.		Hz	250	250	250	120
Rated clock cycle		kHz	3	3	2.4	2.4
adjustable from	kHz	2 ... 5	2 ... 5	1.5 ... 3.7	1.5 ... 3.7	1.5 ... 3.7
Power loss ³⁾		kW	6.15	7.73	9.37	12.2
Rated efficiency		%	97.7	97.7	97.8	97.7
Electrical data at line end						
Connected load		kVA	312	391	502	608
Rated input voltage		V	690	690	690	690
Input current						
• Continuous line current	A	261	327	420	509	566
• Short-time line current (60 s) max.	A	309	394	487	615	681
Line fuse (provided by customer)		gL (A)	315	400	500	630
λ_{line}			0.901	0.905	0.91	0.939
Cos ϕ_{line}			1	1	1	1
Radio interference suppression acc. to EN 61800-3 ⁴⁾			C3 (class A filter)	C3 (class A filter)	C3 (class A filter)	C3 (class A filter)
Mechanical data						
Frame size (dimensional drawing classification)		SL2	SL2	SL2	SL21	SL3
Sound pressure level L _{pA} (1 m) at 50/60 Hz		dB	70	70	70	75
Standard converter dimensions						
• Width	mm	806	806	806	1206	1606
• Height ⁵⁾	mm	2112	2112	2112	2112	2112
• Depth	mm	605	605	605	605	605
Coolant requirements		m ³ /h	1900	1900	1900	2650
Weight, approx.		kg	490	510	530	780
General mechanical data						
Max. cable length between converter and motor with standard insulation (shielded)		m	100/250 ⁶⁾	100/250 ⁶⁾	100/250 ⁶⁾	100/250 ⁶⁾
Line/load connection						
L1, L2, L3/U2, V2, W2						
For connection cross-sections, see "Cable cross-sections and connections" in section "Configuring instructions"						

¹⁾ Rated power of a typical 2- to 6-pole standard motor.

²⁾ Typical output voltage dependent on filter and unit type.

³⁾ Maximum power loss with continuous motor current.

⁴⁾ EMC filter not required for IT system, in which case RI suppression category C4.

⁵⁾ With IP21 protective top cover (110 mm).

⁶⁾ Value is applicable with option L10 (strengthened dv/dt filter; filter is integrated in additional 400 mm cabinet).

⁷⁾ Value is applicable with option L10 (strengthened dv/dt filter; filter is integrated in unit).

Technical data
690 V, 6-pulse (continued)

Line voltage, supply system type		400, 415, 460, 500, 575, 690 V 3 AC TT/TN or IT				
SINAMICS G180 cabinet units		6SE0180-1B■36-4AA7	6SE0180-1B■37-1AA7	6SE0180-1B■37-7AA7	6SE0180-1B■41-0AA7	6SE0180-1B■41-1AA7
Converter type		2T3A-87601-630	2T3A-87601-710	2T3A-87601-800	2T3A-87601-909	2T3A-87601-910
Electrical data at motor end						
Type rating¹⁾						
• at 50 Hz 690 V	kW	630	710	800	900	1000
• at 60 Hz 575 V	hp	704	794	894	1006	1118
Output voltage²⁾	V	0 ... 0.98 × V _{line}				
Output current						
• Continuous current	A	660	750	840	950	1040
• Short-time current (60 s every 10 minutes) max.	A	800	890	980	1060	1130
Output power	kVA	789	896	1004	1135	1243
Output frequency, max.	Hz	120	120	120	120	120
Rated clock cycle	kHz	2.4	2.4	2.4	2.4	2.4
adjustable from	kHz	1.5 ... 3.7	1.5 ... 3.7	1.5 ... 3.7	1.5 ... 3.7	1.5 ... 3.7
Power loss³⁾	kW	15.4	16.6	18.7	21	23.3
Rated efficiency	%	97.7	97.8	97.8	97.8	97.8
Electrical data at line end						
Connected load	kVA	764	854	956	1078	1165
Rated input voltage	V	690	690	690	690	690
Input current						
• Continuous line current	A	639	715	800	902	975
• Short-time line current (60 s) max.	A	774	848	933	1006	1059
Line fuse (provided by customer)	gL (A)	800	800	900	1000	1000
λ_{line}		0.942	0.944	0.945	0.947	0.949
$\cos \varphi_{\text{line}}$		1	1	1	1	1
Radio interference suppression acc. to EN 61800-3⁴⁾		C3 (class A filter)	C3 (class A filter)	C3 (class A filter)	C3 (class A filter)	C3 (class A filter)
Mechanical data						
Frame size (dimensional drawing classification)	SL3	SL3	SL3	SL3	SL3	SL3
Sound pressure level L_{pA} (1 m) at 50/60 Hz	dB	75	75	75	75	75
Standard converter dimensions						
• Width	mm	1606	1606	1606	1606	1606
• Height ⁵⁾	mm	2112	2112	2112	2112	2112
• Depth	mm	605	605	605	605	605
Coolant requirements	m ³ /h	3200	3800	3200	3800	3800
Weight, approx.	kg	890	900	930	980	1030
General mechanical data						
Max. cable length between converter and motor with standard insulation (shielded)	m	100/250 ⁶⁾	100/250 ⁶⁾	100/250 ⁷⁾	100/250 ⁷⁾	100/250 ⁷⁾
Line/load connection						
L1, L2, L3/U2, V2, W2						
For connection cross-sections, see "Cable cross-sections and connections" in section "Configuring instructions"						

¹⁾ Rated power of a typical 2- to 6-pole standard motor.

²⁾ Typical output voltage dependent on filter and unit type.

³⁾ Maximum power loss with continuous motor current.

⁴⁾ EMC filter not required for IT system, in which case RI suppression category C4.

⁵⁾ With IP21 protective top cover (110 mm).

⁶⁾ Value is applicable with option L10 (strengthened dv/dt filter; filter is integrated in unit).

⁷⁾ Value is applicable with option L10 (strengthened dv/dt filter; filter is integrated in additional 600 mm cabinet).

SINAMICS G180

SINAMICS G180 cabinet units

SINAMICS G180 cabinet units air-cooled

Technical data

690 V, 6-pulse (continued)

Line voltage, supply system type		400, 415, 460, 500, 575, 690 V 3 AC TT/TN or IT					
SINAMICS G180 cabinet units		6SE0180-1C■41-2AA7	6SE0180-1C■41-3AA7	6SE0180-1C■41-5AA7	6SE0180-1C■41-7AA7	6SE0180-1C■42-0AA7	
Converter type		2T3A-87602-912	2T3A-87602-913	2T3A-87602-915	2T3A-87602-917	2T3A-87602-919	
Electrical data at motor end							
Type rating ¹⁾							
• at 50 Hz 690 V	kW	1200	1300	1500	1700	1900	
• at 60 Hz 575 V	hp	1341	1453	1676	1900	2123	
Output voltage ²⁾		V 0 ... 0.98 × V _{line}					
Output current							
• Continuous current	A	1260	1430	1600	1810	1980	
• Short-time current (60 s every 10 minutes) max.	A	1520	1700	1870	2020	2150	
Output power		kVA	1506	1709	1912	2163	2366
Output frequency, max.		Hz	120	120	120	120	120
Rated clock cycle		kHz	2.4	2.4	2.4	2.4	2.4
adjustable from	kHz	1.5 ... 3.7	1.5 ... 3.7	1.5 ... 3.7	1.5 ... 3.7	1.5 ... 3.7	
Power loss ³⁾		kW	28.2	33.6	37.5	42.6	46.5
Rated efficiency		%	97.8	97.7	97.7	97.7	97.7
Electrical data at line end							
Connected load		kVA	1410	1603	1795	2030	2220
Rated input voltage		V	690	690	690	690	690
Input current							
• Continuous line current	A	1180	1341	1502	1699	1858	
• Short-time line current (60 s) max.	A	1424	1594	1756	1896	2018	
Line fuse (provided by customer)		gL (A)	1250	1500	1600	1800	2000
λ_{line}			0.952	0.954	0.956	0.958	0.96
Cos ϕ_{line}			1	1	1	1	1
Radio interference suppression acc. to EN 61800-3 ⁴⁾			C3 (class A filter)	C3 (class A filter)	C3 (class A filter)	C3 (class A filter)	C3 (class A filter)
Mechanical data							
Frame size (dimensional drawing classification)		SL4	SL4	SL4	SL4	SL4	
Sound pressure level L_{pA} (1 m) at 50/60 Hz		dB	77	77	77	77	77
Standard converter dimensions							
• Width	mm	3206	3206	3206	3206	3206	
• Height ⁵⁾	mm	2112	2112	2112	2112	2112	
• Depth	mm	605	605	605	605	605	
Coolant requirements		m ³ /h	6400	7600	6400	7600	7600
Weight, approx.		kg	1780	1800	1860	1960	2060
General mechanical data							
Max. cable length between converter and motor with standard insulation (shielded)		m	100/250 ⁶⁾	100/250 ⁶⁾	100/250 ⁷⁾	100/250 ⁷⁾	100/250 ⁷⁾
Line/load connection							
L1, L2, L3/U2, V2, W2							
For connection cross-sections, see "Cable cross-sections and connections" in section "Configuring instructions"							

¹⁾ Rated power of a typical 2- to 6-pole standard motor.

²⁾ Typical output voltage dependent on filter and unit type.

³⁾ Maximum power loss with continuous motor current.

⁴⁾ EMC filter not required for IT system, in which case RI suppression category C4.

⁵⁾ With IP21 protective top cover (110 mm).

⁶⁾ Value is applicable with option L10 (strengthened dv/dt filter; filter is integrated in unit).

⁷⁾ Value is applicable with option L10 (strengthened dv/dt filter; filter is integrated in additional 2 × 600 mm cabinet).

Technical data
690 V, 12-pulse

Line voltage, supply system type		2 × 400, 415, 460, 500, 575, 690 V 3 AC IT				
SINAMICS G180 cabinet units		6SE0180-2BH33-2AA7	6SE0180-2BH33-6AA7	6SE0180-2BH34-2AA7	6SE0180-2BH35-2AA7	6SE0180-2BH35-7AA7
Converter type		2T3F-87601-250	2T3F-87601-315	2T3F-87601-400	2T3F-87601-500	2T3F-87601-560
Electrical data at motor end						
Type rating ¹⁾						
• at 50 Hz 690 V	kW	250	315	400	500	560
• at 60 Hz 575 V	hp	279	352	447	559	626
Output voltage ²⁾		V	0 ... 0.98 × V _{line}	0 ... 0.98 × V _{line}	0 ... 0.98 × V _{line}	0 ... 0.98 × V _{line}
Output current						
• Continuous current	A	270	340	440	530	590
• Short-time current (60 s every 10 minutes) max.	A	320	410	510	640	710
Output power		kVA	323	406	526	633
Output frequency, max.		Hz	250	250	250	120
Rated clock cycle		kHz	3	3	2.4	2.4
adjustable from	kHz	2 ... 5	2 ... 5	1.5 ... 3.7	1.5 ... 3.7	1.5 ... 3.7
Power loss ³⁾		kW	6.15	7.73	9.37	12.2
Rated efficiency		%	97.7	97.7	97.8	97.7
Electrical data at line end						
Connected load		kVA	311	392	502	600
Rated input voltage		V	2 × 690	2 × 690	2 × 690	2 × 690
Input current						
• Continuous line current	A	2 × 130	2 × 164	2 × 210	2 × 251	2 × 279
• Short-time line current (60 s) max.	A	2 × 154	2 × 198	2 × 243	2 × 303	2 × 336
Line fuse (provided by customer)		gL (A)	160	200	250	315
λ_{line}			0.995	0.995	0.995	0.997
Cos ϕ_{line}			1	1	1	1
Radio interference suppression acc. to EN 61800-3			C4	C4	C4	C4
Mechanical data						
Frame size (dimensional drawing classification)		SL5	SL5	SL5	SL5	SL6
Sound pressure level L_{pA} (1 m) at 50/60 Hz		dB	70	70	70	75
Standard converter dimensions						
• Width	mm	1406	1406	1406	1406	1806
• Height ⁴⁾	mm	2112	2112	2112	2112	2112
• Depth	mm	605	605	605	605	605
Coolant requirements		m ³ /h	1900	1900	1900	2650
Weight, approx.		kg	690	710	730	810
General mechanical data						
Max. cable length between converter and motor with standard insulation (shielded)		m	100/250 ⁵⁾	100/250 ⁵⁾	100/250 ⁵⁾	100/250 ⁶⁾
Line/load connection						
L1, L2, L3/U2, V2, W2						
For connection cross-sections, see "Cable cross-sections and connections" in section "Configuring instructions"						

¹⁾ Rated power of a typical 2- to 6-pole standard motor.

²⁾ Typical output voltage dependent on filter and unit type.

³⁾ Maximum power loss with continuous motor current.

⁴⁾ With IP21 protective top cover (110 mm).

⁵⁾ Value is applicable with option L10 (strengthened dv/dt filter; filter is integrated in additional 400 mm cabinet).

⁶⁾ Value is applicable with option L10 (strengthened dv/dt filter; filter is integrated in unit).

SINAMICS G180

SINAMICS G180 cabinet units

SINAMICS G180 cabinet units air-cooled

Technical data

690 V, 12-pulse (continued)

Line voltage, supply system type		2 × 400, 415, 460, 500, 575, 690 V 3 AC IT				
SINAMICS G180 cabinet units		6SE0180-2BH36-4AA7	6SE0180-2BH37-1AA7	6SE0180-2BH37-7AA7	6SE0180-2BH41-0AA7	6SE0180-2BH41-1AA7
Converter type		2T3F-87601-630	2T3F-87601-710	2T3F-87601-800	2T3F-87601-909	2T3F-87601-910
Electrical data at motor end						
Type rating ¹⁾						
• at 50 Hz 690 V	kW	630	710	800	900	1000
• at 60 Hz 575 V	hp	704	794	894	1006	1118
Output voltage ²⁾		V	0 ... 0.98 × V _{line}	0 ... 0.98 × V _{line}	0 ... 0.98 × V _{line}	0 ... 0.98 × V _{line}
Output current						
• Continuous current	A	660	750	840	950	1040
• Short-time current (60 s every 10 minutes) max.	A	800	890	980	1060	1130
Output power		kVA	789	896	1004	1135
Output frequency, max.		Hz	120	120	120	120
Rated clock cycle		kHz	2.4	2.4	2.4	2.4
adjustable from	kHz	1.5 ... 3.7	1.5 ... 3.7	1.5 ... 3.7	1.5 ... 3.7	1.5 ... 3.7
Power loss ³⁾		kW	15.4	16.6	18.7	21
Rated efficiency		%	97.7	97.8	97.8	97.8
Electrical data at line end						
Connected load		kVA	755	848	949	1071
Rated input voltage		V	2 × 690	2 × 690	2 × 690	2 × 690
Input current						
• Continuous line current	A	2 × 316	2 × 355	2 × 397	2 × 448	2 × 485
• Short-time line current (60 s) max.	A	2 × 383	2 × 421	2 × 463	2 × 500	2 × 527
Line fuse (provided by customer)		gL (A)	400	400	500	630
λ_{line}			0.997	0.997	0.997	0.997
Cos ϕ_{line}			1	1	1	1
Radio interference suppression acc. to EN 61800-3			C4	C4	C4	C4
Mechanical data						
Frame size (dimensional drawing classification)		SL6	SL6	SL6	SL6	SL6
Sound pressure level L_{pA} (1 m) at 50/60 Hz		dB	75	75	75	75
Standard converter dimensions						
• Width	mm	1806	1806	1806	1806	1806
• Height ⁴⁾	mm	2112	2112	2112	2112	2112
• Depth	mm	605	605	605	605	605
Coolant requirements		m ³ /h	3200	3800	3200	3800
Weight, approx.		kg	920	930	960	1010
General mechanical data						
Max. cable length between converter and motor with standard insulation (shielded)		m	100/250 ⁵⁾	100/250 ⁵⁾	100/250 ⁶⁾	100/250 ⁶⁾
Line/load connection						
L1, L2, L3/U2, V2, W2						
For connection cross-sections, see "Cable cross-sections and connections" in section "Configuring instructions"						

¹⁾ Rated power of a typical 2- to 6-pole standard motor.

²⁾ Typical output voltage dependent on filter and unit type.

³⁾ Maximum power loss with continuous motor current.

⁴⁾ With IP21 protective top cover (110 mm).

⁵⁾ Value is applicable with option L10 (strengthened dv/dt filter; filter is integrated in unit).

⁶⁾ Value is applicable with option L10 (strengthened dv/dt filter; filter is integrated in additional 600 mm cabinet).

Technical data
690 V, 12-pulse (continued)

Line voltage, supply system type		2 × 400, 415, 460, 500, 575, 690 V 3 AC IT				
SINAMICS G180 cabinet units		6SE0180-2CH41-2AA7	6SE0180-2CH41-3AA7	6SE0180-2CH41-5AA7	6SE0180-2CH41-7AA7	6SE0180-2CH42-0AA7
<i>Converter type</i>		<i>2T3F-87602-912</i>	<i>2T3F-87602-913</i>	<i>2T3F-87602-915</i>	<i>2T3F-87602-917</i>	<i>2T3F-87602-919</i>
Electrical data at motor end						
Type rating¹⁾						
• at 50 Hz 690 V	kW	1200	1300	1500	1700	1900
• at 60 Hz 575 V	hp	1341	1453	1676	1900	2123
Output voltage²⁾	V	0 ... 0.98 × V _{line}	0 ... 0.98 × V _{line}	0 ... 0.98 × V _{line}	0 ... 0.98 × V _{line}	0 ... 0.98 × V _{line}
Output current						
• Continuous current	A	1260	1430	1600	1810	1980
• Short-time current (60 s every 10 minutes) max.	A	1520	1700	1870	2020	2150
Output power	kVA	1506	1709	1912	2163	2366
Output frequency, max.	Hz	120	120	120	120	120
Rated clock cycle	kHz	2.4	2.4	2.4	2.4	2.4
adjustable from	kHz	1.5 ... 3.7	1.5 ... 3.7	1.5 ... 3.7	1.5 ... 3.7	1.5 ... 3.7
Power loss³⁾	kW	28.2	33.6	37.5	42.6	46.5
Rated efficiency	%	97.8	97.7	97.7	97.7	97.7
Electrical data at line end						
Connected load	kVA	1405	1597	1781	2010	2194
Rated input voltage	V	2 × 690	2 × 690	2 × 690	2 × 690	2 × 690
Input current						
• Continuous line current	A	2 × 588	2 × 668	2 × 745	2 × 841	2 × 918
• Short-time line current (60 s) max.	A	2 × 709	2 × 794	2 × 871	2 × 939	2 × 997
Line fuse (provided by customer)	gL (A)	800	800	900	1000	1250
λ_{line}		0.997	0.997	0.997	0.997	0.997
cos ϕ_{line}		1	1	1	1	1
Radio interference suppression acc. to EN 61800-3		C4	C4	C4	C4	C4
Mechanical data						
Frame size (dimensional drawing classification)		SL4	SL4	SL4	SL4	SL4
Sound pressure level L_{pA} (1 m) at 50/60 Hz	dB	77	77	77	77	77
Standard converter dimensions						
• Width	mm	3206	3206	3206	3206	3206
• Height ⁴⁾	mm	2112	2112	2112	2112	2112
• Depth	mm	605	605	605	605	605
Coolant requirements	m ³ /h	6400	7600	6400	7600	7600
Weight, approx.	kg	1780	1800	1860	1960	2060
General mechanical data						
Max. cable length between converter and motor with standard insulation (shielded)	m	100/250 ⁵⁾	100/250 ⁵⁾	100/250 ⁶⁾	100/250 ⁶⁾	100/250 ⁶⁾
Line/load connection						
L1, L2, L3/U2, V2, W2						
For connection cross-sections, see "Cable cross-sections and connections" in section "Configuring instructions"						

¹⁾ Rated power of a typical 2- to 6-pole standard motor.

²⁾ Typical output voltage dependent on filter and unit type.

³⁾ Maximum power loss with continuous motor current.

⁴⁾ With IP21 protective top cover (110 mm).

⁵⁾ Value is applicable with option L10 (strengthened dv/dt filter; filter is integrated in unit).

⁶⁾ Value is applicable with option L10 (strengthened dv/dt filter; filter is integrated in additional 2 × 600 mm cabinet).

SINAMICS G180

SINAMICS G180 cabinet units

SINAMICS G180 cabinet units air-cooled

Technical data

690 V, 12-pulse (continued)

Line voltage, supply system type		2 × 400, 415, 460, 500, 575, 690 V 3 AC IT				
SINAMICS G180 cabinet units		6SE0180-2DH42-2AA7	6SE0180-2DH42-4AA7	6SE0180-2DH42-7AA7	6SE0180-2DH43-0AA7	6SE0180-2EH43-2AA7
Converter type		2T3F-87603-920	2T3F-87603-923	2T3F-87603-926	2T3F-87603-929	2T3F-87604-931
Electrical data at motor end						
Type rating ¹⁾						
• at 50 Hz 690 V	kW	2000	2300	2600	2900	3100
• at 60 Hz 575 V	hp	2235	2570	2906	3241	3465
Output voltage ²⁾		V	0 ... 0.98 × V _{line}	0 ... 0.98 × V _{line}	0 ... 0.98 × V _{line}	0 ... 0.98 × V _{line}
Output current						
• Continuous current	A	2140	2400	2710	2970	3200
• Short-time current (60 s every 10 minutes) max.	A	2540	2800	3030	3230	3730
Output power		kVA	2558	2868	3239	3824
Output frequency, max.		Hz	120	120	120	120
Rated clock cycle		kHz	2.4	2.4	2.4	2.4
adjustable from	kHz	1.5 ... 3.7	1.5 ... 3.7	1.5 ... 3.7	1.5 ... 3.7	1.5 ... 3.7
Power loss ³⁾		kW	50.9	57.2	64.5	73.9
Rated efficiency		%	97.7	97.7	97.7	97.7
Electrical data at line end						
Connected load		kVA	2369	2648	2983	3272
Rated input voltage		V	2 × 690	2 × 690	2 × 690	2 × 690
Input current						
• Continuous line current	A	2 × 991	2 × 1108	2 × 1248	2 × 1369	2 × 1471
• Short-time line current (60 s) max.	A	2 × 1176	2 × 1293	2 × 1395	2 × 1489	2 × 1715
Line fuse (provided by customer)		gL (A)	1250	1250	1500	1800
λ_{line}			0.997	0.997	0.997	0.997
Cos ϕ_{line}			1	1	1	1
Radio interference suppression acc. to EN 61800-3			C4	C4	C4	C4
Mechanical data						
Frame size (dimensional drawing classification)		SL7	SL7	SL7	SL7	SL8
Sound pressure level L_{pA} (1 m) at 50/60 Hz		dB	78	78	78	79
Standard converter dimensions						
• Width	mm	4806	4806	4806	4806	6406
• Height ⁴⁾	mm	2112	2112	2112	2112	2112
• Depth	mm	605	605	605	605	605
Coolant requirements		m ³ /h	11400	9600	11400	12800
Weight, approx.		kg	2700	2790	2940	3720
General mechanical data						
Max. cable length between converter and motor with standard insulation (shielded)		m	100/250 ⁵⁾	100/250 ⁶⁾	100/250 ⁶⁾	100/250 ⁷⁾
Line/load connection						
L1, L2, L3/U2, V2, W2						
For connection cross-sections, see "Cable cross-sections and connections" in section "Configuring instructions"						

¹⁾ Rated power of a typical 2- to 6-pole standard motor.

²⁾ Typical output voltage dependent on filter and unit type.

³⁾ Maximum power loss with continuous motor current.

⁴⁾ With IP21 protective top cover (110 mm).

⁵⁾ Value is applicable with option L10 (strengthened dv/dt filter; filter is integrated in unit).

⁶⁾ Value is applicable with option L10 (strengthened dv/dt filter; filter is integrated in additional 3 × 600 mm cabinet).

⁷⁾ Value is applicable with option L10 (strengthened dv/dt filter; filter is integrated in additional 4 × 600 mm cabinet).

Technical data
690 V, 12-pulse (continued)

Line voltage, supply system type	2 × 400, 415, 460, 500, 575, 690 V 3 AC IT		
SINAMICS G180 cabinet units	6SE0180-2EH43-6AA7	6SE0180-2EH44-0AA7	
<i>Converter type</i>	<i>2T3F-87604-935</i>	<i>2T3F-87604-939</i>	higher output up to 6700 kW available
Electrical data at motor end			
Type rating¹⁾			
• at 50 Hz 690 V	kW	3500	3900
• at 60 Hz 575 V	hp	3912	4359
Output voltage²⁾	V	0 ... 0.98 × V _{line}	0 ... 0.98 × V _{line}
Output current			
• Continuous current	A	3610	3960
• Short-time current (60 s every 10 minutes) max.	A	4030	4300
Output power	kVA	4314	4732
Output frequency, max.	Hz	120	120
Rated clock cycle	kHz	2.4	2.4
adjustable from	kHz	1.5 ... 3.7	1.5 ... 3.7
Power loss³⁾	kW	87.3	99.7
Rated efficiency	%	97.7	97.6
Electrical data at line end			
Connected load	kVA	3956	4336
Rated input voltage	V	2 × 690	2 × 690
Input current			
• Continuous line current	A	2 × 1655	2 × 1814
• Short-time line current (60 s) max.	A	2 × 1848	2 × 1970
Line fuse (provided by customer)	gL (A)	2000	2000
λ_{line}		0.997	0.997
cos ϕ_{line}		1	1
Radio interference suppression acc. to EN 61800-3		C4	C4
Mechanical data			
Frame size (dimensional drawing classification)	SL8	SL8	
Sound pressure level L_{pA} (1 m) at 50/60 Hz	dB	79	79
Standard converter dimensions			
• Width	mm	6406	6406
• Height ⁴⁾	mm	2112	2112
• Depth	mm	605	605
Coolant requirements	m ³ /h	15200	15200
Weight, approx.	kg	3920	4120
General mechanical data			
Max. cable length between converter and motor with standard insulation (shielded)	m	100/250 ⁵⁾	100/250 ⁵⁾
Line/load connection			
L1, L2, L3/U2, V2, W2			
For connection cross-sections, see "Cable cross-sections and connections" in section "Configuring instructions"			

¹⁾ Rated power of a typical 2- to 6-pole standard motor.

²⁾ Typical output voltage dependent on filter and unit type.

³⁾ Maximum power loss with continuous motor current.

⁴⁾ With IP21 protective top cover (110 mm).

⁵⁾ Value is applicable with option L10 (strengthened dv/dt filter; filter is integrated in additional 4 × 600 mm cabinet).

SINAMICS G180

SINAMICS G180 cabinet units

SINAMICS G180 cabinet units air-cooled

Technical data

690 V, 18-pulse

Line voltage, supply system type		3 × 400, 415, 460, 500, 575, 690 V 3 AC IT					
SINAMICS G180 cabinet units		6SE0180-3DH42-2AA7	6SE0180-3DH42-4AA7	6SE0180-3DH42-7AA7	6SE0180-3DH43-0AA7	6SE0180-3HH44-3AA7	
Converter type		2T3K-87603-920	2T3K-87603-923	2T3K-87603-926	2T3K-87603-929	2T3K-87606-941	
Electrical data at motor end							
Type rating ¹⁾							
• at 50 Hz 690 V	kW	2000	2300	2600	2900	4100	
• at 60 Hz 575 V	hp	2235	2570	2906	3241	4582	
Output voltage ²⁾		V 0 ... 0.98 × V _{line}					
Output current							
• Continuous current	A	2140	2400	2710	2970	4290	
• Short-time current (60 s every 10 minutes) max.	A	2540	2800	3030	3230	5100	
Output power		kVA	2558	2868	3239	3549	5127
Output frequency, max.		Hz	120	120	120	120	120
Rated clock cycle		kHz	2.4	2.4	2.4	2.4	2.4
adjustable from		kHz	1.5 ... 3.7	1.5 ... 3.7	1.5 ... 3.7	1.5 ... 3.7	1.5 ... 3.7
Power loss ³⁾		kW	50.9	57.2	64.5	73.9	102
Rated efficiency		%	97.7	97.7	97.7	97.6	97.7
Electrical data at line end							
Connected load		kVA	2369	2648	2983	3272	4692
Rated input voltage		V	3 × 690	3 × 690	3 × 690	3 × 690	3 × 690
Input current							
• Continuous line current	A	3 × 661	3 × 739	3 × 832	3 × 912	3 × 1308	
• Short-time line current (60 s) max.	A	3 × 785	3 × 862	3 × 930	3 × 992	3 × 1555	
Line fuse (provided by customer)		gL (A)	800	900	1000	1250	1500
λ_{line}			1	1	1	1	1
Cos ϕ_{line}			1	1	1	1	1
Radio interference suppression acc. to EN 61800-3			C4	C4	C4	C4	C4
Mechanical data							
Frame size (dimensional drawing classification)		SL7	SL7	SL7	SL7	SL11	
Sound pressure level L_{pA} (1 m) at 50/60 Hz		dB	78	78	78	78	79
Standard converter dimensions							
• Width	mm	4806	4806	4806	4806	10206	
• Height ⁴⁾	mm	2112	2112	2112	2112	2112	
• Depth	mm	605	605	605	605	605	
Coolant requirements		m ³ /h	11400	9600	11400	11400	23150
Weight, approx.		kg	2750	2840	2990	3140	5750
General mechanical data							
Max. cable length between converter and motor with standard insulation (shielded)		m	100/250 ⁵⁾	100/250 ⁶⁾	100/250 ⁶⁾	100/250 ⁶⁾	100/250 ⁵⁾
Line/load connection							
L1, L2, L3/U2, V2, W2							
For connection cross-sections, see "Cable cross-sections and connections" in section "Configuring instructions"							

¹⁾ Rated power of a typical 2- to 6-pole standard motor.

²⁾ Typical output voltage dependent on filter and unit type.

³⁾ Maximum power loss with continuous motor current.

⁴⁾ With IP21 protective top cover (110 mm).

⁵⁾ Value is applicable with option L10 (strengthened dv/dt filter; filter is integrated in unit).

⁶⁾ Value is applicable with option L10 (strengthened dv/dt filter; filter is integrated in additional 3 × 600 mm cabinet).

Technical data
690 V, 18-pulse (continued)

Line voltage, supply system type		3 × 400, 415, 460, 500, 575, 690 V 3 AC IT		
SINAMICS G180 cabinet units		6SE0180-3HH44-8AA7	6SE0180-3HH45-4AA7	6SE0180-3HH46-0AA7
<i>Converter type</i>		<i>2T3K-87606-947</i>	<i>2T3K-87606-953</i>	<i>2T3K-87606-958</i>
Electrical data at motor end				
Type rating¹⁾				
• at 50 Hz 690 V	kW	4700	5300	5800
• at 60 Hz 575 V	hp	5253	5923	6482
Output voltage²⁾	V	0 ... 0.98 × V _{line}	0 ... 0.98 × V _{line}	0 ... 0.98 × V _{line}
Output current				
• Continuous current	A	4800	5420	5940
• Short-time current (60 s every 10 minutes) max.	A	5610	6040	6450
Output power	kVA	5736	6477	7099
Output frequency, max.	Hz	120	120	120
Rated clock cycle	kHz	2.4	2.4	2.4
adjustable from	kHz	1.5 ... 3.7	1.5 ... 3.7	1.5 ... 3.7
Power loss³⁾	kW	110	118	129
Rated efficiency	%	97.8	97.9	97.9
Electrical data at line end				
Connected load	kVA	5244	5916	6482
Rated input voltage	V	3 × 690	3 × 690	3 × 690
Input current				
• Continuous line current	A	3 × 1462	3 × 1651	3 × 1809
• Short-time line current (60 s) max.	A	3 × 1709	3 × 1840	3 × 1964
Line fuse (provided by customer)	gL (A)	1800	2000	2000 ... 2500
λ_{line}		1	1	1
$\text{Cos } \varphi_{\text{line}}$		1	1	1
Radio interference suppression acc. to EN 61800-3		C4	C4	C4
Mechanical data				
Frame size (dimensional drawing classification)		SL11	SL11	SL11
Sound pressure level L_{pA} (1 m) at 50/60 Hz	dB	79	79	79
Standard converter dimensions				
• Width	mm	10206	10206	10206
• Height ⁴⁾	mm	2112	2112	2112
• Depth	mm	605	605	605
Coolant requirements	m ³ /h	19550	23150	23150
Weight, approx.	kg	5930	6230	6530
General mechanical data				
Max. cable length between converter and motor with standard insulation (shielded)	m	100/250 ⁵⁾	100/250 ⁵⁾	100/250 ⁵⁾
Line/load connection L1, L2, L3/U2, V2, W2 For connection cross-sections, see "Cable cross-sections and connections" in section "Configuring instructions"				

¹⁾ Rated power of a typical 2- to 6-pole standard motor.

²⁾ Typical output voltage dependent on filter and unit type.

³⁾ Maximum power loss with continuous motor current.

⁴⁾ With IP21 protective top cover (110 mm).

⁵⁾ Value is applicable with option L10 (strengthened dv/dt filter; filter is integrated in additional 6 × 600 mm cabinet).

SINAMICS G180

SINAMICS G180 cabinet units

SINAMICS G180 cabinet units air-cooled

Technical data

690 V, 24-pulse

Line voltage, supply system type		4 × 400, 415, 460, 500, 575, 690 V 3 AC IT				
SINAMICS G180 cabinet units		6SE0180-4CH41-2AA7	6SE0180-4CH41-3AA7	6SE0180-4CH41-5AA7	6SE0180-4CH41-7AA7	6SE0180-4CH42-0AA7
Converter type		2T3L-87602-912	2T3L-87602-913	2T3L-87602-915	2T3L-87602-917	2T3L-87602-919
Electrical data at motor end						
Type rating ¹⁾						
• at 50 Hz 690 V	kW	1200	1300	1500	1700	1900
• at 60 Hz 575 V	hp	1341	1453	1676	1900	2123
Output voltage ²⁾		V	0 ... 0.98 × V _{line}	0 ... 0.98 × V _{line}	0 ... 0.98 × V _{line}	0 ... 0.98 × V _{line}
Output current						
• Continuous current	A	1260	1430	1600	1810	1980
• Short-time current (60 s every 10 minutes) max.	A	1520	1700	1870	2020	2150
Output power		kVA	1506	1709	1912	2163
Output frequency, max.		Hz	120	120	120	120
Rated clock cycle		kHz	2.4	2.4	2.4	2.4
adjustable from	kHz	1.5 ... 3.7	1.5 ... 3.7	1.5 ... 3.7	1.5 ... 3.7	1.5 ... 3.7
Power loss ³⁾		kW	28.2	33.6	37.5	42.6
Rated efficiency		%	97.8	97.7	97.7	97.7
Electrical data at line end						
Connected load		kVA	1405	1597	1781	2010
Rated input voltage		V	4 × 690	4 × 690	4 × 690	4 × 690
Input current						
• Continuous line current	A	4 × 294	4 × 333	4 × 372	4 × 421	4 × 459
• Short-time line current (60 s) max.	A	4 × 355	4 × 396	4 × 435	4 × 470	4 × 498
Line fuse (provided by customer)		gL (A)	400	400	500	630
λ_{line}			1	1	1	1
Cos ϕ_{line}			1	1	1	1
Radio interference suppression acc. to EN 61800-3			C4	C4	C4	C4
Mechanical data						
Frame size (dimensional drawing classification)		SL9	SL9	SL9	SL9	SL9
Sound pressure level L_{pA} (1 m) at 50/60 Hz		dB	77	77	77	77
Standard converter dimensions						
• Width	mm	3606	3606	3606	3606	3606
• Height ⁴⁾	mm	2112	2112	2112	2112	2112
• Depth	mm	605	605	605	605	605
Coolant requirements		m ³ /h	6400	7600	6400	7600
Weight, approx.		kg	1830	1850	1910	2110
General mechanical data						
Max. cable length between converter and motor with standard insulation (shielded)		m	100/250 ⁵⁾	100/250 ⁵⁾	100/250 ⁶⁾	100/250 ⁶⁾
Line/load connection		L1, L2, L3/U2, V2, W2				
For connection cross-sections, see "Cable cross-sections and connections" in section "Configuring instructions"						

¹⁾ Rated power of a typical 2- to 6-pole standard motor.

²⁾ Typical output voltage dependent on filter and unit type.

³⁾ Maximum power loss with continuous motor current.

⁴⁾ With IP21 protective top cover (110 mm).

⁵⁾ Value is applicable with option L10 (strengthened dv/dt filter; filter is integrated in unit).

⁶⁾ Value is applicable with option L10 (strengthened dv/dt filter; filter is integrated in additional 600 mm cabinet).

Technical data
690 V, 24-pulse (continued)

Line voltage, supply system type		4 × 400, 415, 460, 500, 575, 690 V 3 AC IT				
SINAMICS G180 cabinet units		6SE0180-4EH43-2AA7	6SE0180-4EH43-6AA7	6SE0180-4EH44-0AA7	6SE0180-4HH44-3AA7	6SE0180-4HH44-8AA7
Converter type		2T3L-87604-931	2T3L-87604-935	2T3L-87604-939	2T3L-87606-941	2T3L-87606-947
Electrical data at motor end						
Type rating ¹⁾						
• at 50 Hz 690 V	kW	3100	3500	3900	4100	4700
• at 60 Hz 575 V	hp	3465	3912	4359	4582	5253
Output voltage ²⁾		V	0 ... 0.98 × V _{line}	0 ... 0.98 × V _{line}	0 ... 0.98 × V _{line}	0 ... 0.98 × V _{line}
Output current						
• Continuous current	A	3200	3610	3960	4290	4800
• Short-time current (60 s every 10 minutes) max.	A	3730	4030	4300	5100	5610
Output power		kVA	3824	4314	4732	5127
Output frequency, max.		Hz	120	120	120	120
Rated clock cycle		kHz	2.4	2.4	2.4	2.4
adjustable from	kHz	1.5 ... 3.7	1.5 ... 3.7	1.5 ... 3.7	1.5 ... 3.7	1.5 ... 3.7
Power loss ³⁾		kW	77.3	87.3	99.7	102
Rated efficiency		%	97.7	97.7	97.6	97.8
Electrical data at line end						
Connected load		kVA	3516	3956	4336	4692
Rated input voltage		V	4 × 690	4 × 690	4 × 690	4 × 690
Input current						
• Continuous line current	A	4 × 735	4 × 828	4 × 906	4 × 982	4 × 1098
• Short-time line current (60 s) max.	A	4 × 857	4 × 924	4 × 984	4 × 1167	4 × 1283
Line fuse (provided by customer)		gL (A)	900	1000	1000 ... 1250	1250
λ _{line}			1	1	1	1
Cos φ _{line}			1	1	1	1
Radio interference suppression acc. to EN 61800-3			C4	C4	C4	C4
Mechanical data						
Frame size (dimensional drawing classification)		SL10	SL10	SL10	SL12	SL12
Sound pressure level L _{pA} (1 m) at 50/60 Hz		dB	79	79	79	79
Standard converter dimensions						
• Width	mm	7206	7206	7206	11406	11406
• Height ⁴⁾	mm	2112	2112	2112	2112	2112
• Depth	mm	605	605	605	605	605
Coolant requirements		m ³ /h	12800	15200	15200	23150
Weight, approx.		kg	3760	3970	4170	5750
General mechanical data						
Max. cable length between converter and motor with standard insulation (shielded)		m	100/250 ⁵⁾	100/250 ⁵⁾	100/250 ⁵⁾	100/250 ⁶⁾
Line/load connection						
L1, L2, L3/U2, V2, W2						
For connection cross-sections, see "Cable cross-sections and connections" in section "Configuring instructions"						

1) Rated power of a typical 2- to 6-pole standard motor.

2) Typical output voltage dependent on filter and unit type.

3) Maximum power loss with continuous motor current.

4) With IP21 protective top cover (110 mm).

5) With option L10 (strengthened dv/dt filter) the filter is integrated in additional 4 × 600 mm cabinet.

6) Value is applicable with option L10 (strengthened dv/dt filter; filter is integrated in unit).

7) Value is applicable with option L10 (strengthened dv/dt filter; filter is integrated in additional 6 × 600 mm cabinet).

SINAMICS G180

SINAMICS G180 cabinet units

SINAMICS G180 cabinet units air-cooled

Technical data

690 V, 24-pulse (continued)

Line voltage, supply system type	4 × 400, 415, 460, 500, 575, 690 V 3 AC IT		
SINAMICS G180 cabinet units	6SE0180-4HH45-4AA7 6SE0180-4HH46-0AA7		
<i>Converter type</i>	2T3L-87606-953 2T3L-87606-958		
Electrical data at motor end			
Type rating¹⁾			
• at 50 Hz 690 V	kW	5300	5800
• at 60 Hz 575 V	hp	5923	6482
Output voltage²⁾	V	0 ... 0.98 × V _{line}	0 ... 0.98 × V _{line}
Output current			
• Continuous current	A	5420	5940
• Short-time current (60 s every 10 minutes) max.	A	6040	6450
Output power	kVA	6477	7099
Output frequency, max.	Hz	120	120
Rated clock cycle	kHz	2.4	2.4
adjustable from	kHz	1.5 ... 3.7	1.5 ... 3.7
Power loss³⁾	kW	118	129
Rated efficiency	%	97.9	97.9
Electrical data at line end			
Connected load	kVA	5916	6482
Rated input voltage	V	4 × 690	4 × 690
Input current			
• Continuous line current	A	4 × 1237	4 × 1357
• Short-time line current (60 s) max.	A	4 × 1378	4 × 1474
Line fuse (provided by customer)	gL (A)	1500	1500 ... 1800
λ_{line}		1	1
$\cos \varphi_{\text{line}}$		1	1
Radio interference suppression acc. to EN 61800-3		C4	C4
Mechanical data			
Frame size (dimensional drawing classification)	SL12	SL12	
Sound pressure level L_{pA} (1 m) at 50/60 Hz	dB	79	79
Standard converter dimensions			
• Width	mm	11406	11406
• Height ⁴⁾	mm	2112	2112
• Depth	mm	605	605
Coolant requirements	m ³ /h	23150	23150
Weight, approx.	kg	6230	6530
General mechanical data			
Max. cable length between converter and motor with standard insulation (shielded)	m	100/250 ⁵⁾	100/250 ⁵⁾
Line/load connection L1, L2, L3/U2, V2, W2 For connection cross-sections, see "Cable cross-sections and connections" in section "Configuring instructions"			

¹⁾ Rated power of a typical 2- to 6-pole standard motor.

²⁾ Typical output voltage dependent on filter and unit type.

³⁾ Maximum power loss with continuous motor current.

⁴⁾ With IP21 protective top cover (110 mm).

⁵⁾ Value is applicable with option L10 (strengthened dv/dt filter; filter is integrated in additional 6 × 600 mm cabinet).

Selection and ordering data
400 V, 6-pulse

SINAMICS G180 cabinet unit (230 to 415 V 3 AC TN/TT system, 50 to 60 Hz)

Converter type	Connected load kVA	Output		Type rating ²⁾ kW	SINAMICS G180 cabinet units, air-cooled Article No.	Version (see options)
		Continuous current A	Short-time current ¹⁾ A			
2T3A-87401-200	249	380	470	200	6SE0180-1BA33-7AA7	A
2T3A-87401-250	300	460	560	250	6SE0180-1BA34-6AA7	A
2T3A-87401-315	403	630	700	315	6SE0180-1BA36-3AA7	B
2T3A-87401-400	476	740	900	400	6SE0180-1BA37-3AA7	C
2T3A-87401-500	603	910	1110	500	6SE0180-1BA38-8AA7	C
2T3A-87401-560	676	1020	1230	560	6SE0180-1BA41-0AA7	D
2T3A-87401-630	761	1140	1370	630	6SE0180-1BA41-1AA7	D

400 V, 12-pulse incl. shift transformer

SINAMICS G180 cabinet unit (230 to 415 V 3 AC TN/TT system, 50 to 60 Hz)

Converter type	Connected load kVA	Output		Type rating ²⁾ kW	SINAMICS G180 cabinet units, air-cooled Article No.	Version (see options)
		Continuous current A	Short-time current ¹⁾ A			
2T3F-87401-200	249	380	470	200	6SE0180-2BA33-7AA7	E
2T3F-87401-250	301	460	560	250	6SE0180-2BA34-6AA7	E
2T3F-87401-315	405	630	700	315	6SE0180-2BA36-3AA7	E
2T3F-87401-400	477	740	900	400	6SE0180-2BA37-3AA7	E
2T3F-87401-500	604	910	1110	500	6SE0180-2BA38-8AA7	E
2T3F-87401-560	676	1020	1230	560	6SE0180-2BA41-0AA7	E
2T3F-87401-630	762	1140	1370	630	6SE0180-2BA41-1AA7	E

Notice:

SINAMICS G180 cabinet units, 400 V, 12-pulse, air-cooled can also be operated on a cost and space-saving shift transformer instead of a three-winding transformer. Here, the first system is supplied directly from the mains via the line reactor, the second via the shift transformer. This transformer is not included in the price of the converter and can be offered separately. The transformer is installed in degree of protection IP00 or, if desired, in a separate control cabinet or, if necessary, can even be integrated in the converter cabinet.

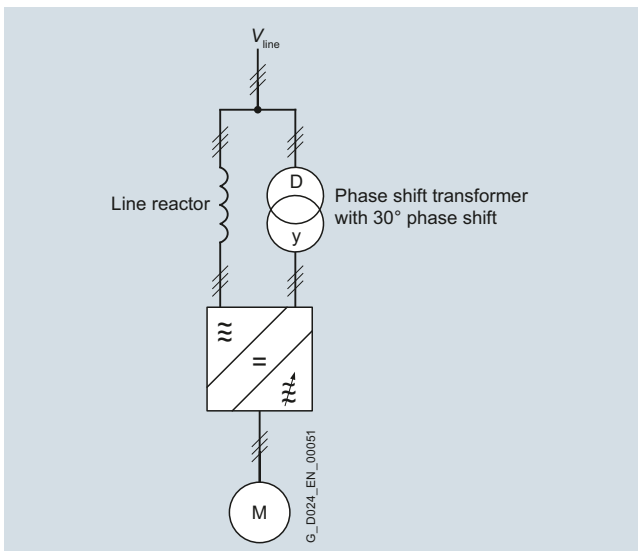
¹⁾ Short-time current for 60 s every 10 minutes.

²⁾ Rated power of a typical 2- to 6-pole standard motor.

SINAMICS G180

SINAMICS G180 cabinet units

SINAMICS G180 cabinet units air-cooled

Selection and ordering data

500 V, 6-pulse

SINAMICS G180 cabinet unit (230 to 500 V 3 AC TN/TT system, 50 to 60 Hz)

Converter type	Connected load kVA	Output		Type rating ²⁾ kW	SINAMICS G180 cabinet units, air-cooled Article No.	Version (see options)
		Continuous current A	Short-time current ¹⁾ A			
2T3A-87501-250	303	370	450	250	6SE0180-1BC33-7AA7	F
2T3A-87501-315	378	460	560	315	6SE0180-1BC34-6AA7	F
2T3A-87501-400	514	640	700	400	6SE0180-1BC36-3AA7	G
2T3A-87501-500	606	730	900	500	6SE0180-1BC37-3AA7	G
2T3A-87501-560	678	820	980	560	6SE0180-1BC38-2AA7	G
2T3A-87501-630	767	920	1100	630	6SE0180-1BC38-8AA7	G
2T3A-87501-710	848	1030	1230	710	6SE0180-1BC41-0AA7	G
2T3A-87501-800	944	1150	1380	800	6SE0180-1BC41-1AA7	G

SINAMICS G180 cabinet unit (230 to 500 V 3 AC IT system, 50 to 60 Hz)

Converter type	Connected load kVA	Output		Type rating ²⁾ kW	SINAMICS G180 cabinet units, air-cooled Article No.	Version (see options)
		Continuous current A	Short-time current ¹⁾ A			
2T3A-87501-250	303	370	450	250	6SE0180-1BD33-7AA7	F
2T3A-87501-315	378	460	560	315	6SE0180-1BD34-6AA7	F
2T3A-87501-400	514	640	700	400	6SE0180-1BD36-3AA7	G
2T3A-87501-500	606	730	900	500	6SE0180-1BD37-3AA7	G
2T3A-87501-560	678	820	980	560	6SE0180-1BD38-2AA7	G
2T3A-87501-630	767	920	1100	630	6SE0180-1BD38-8AA7	G
2T3A-87501-710	848	1030	1230	710	6SE0180-1BD41-0AA7	G
2T3A-87501-800	944	1150	1380	800	6SE0180-1BD41-1AA7	G

500 V, 12-pulse

SINAMICS G180 cabinet unit (3 × 230 to 500 V 3 AC IT system, 50 to 60 Hz)

Converter type	Connected load kVA	Output		Type rating ²⁾ kW	SINAMICS G180 cabinet units, air-cooled Article No.	Version (see options)
		Continuous current A	Short-time current ¹⁾ A			
2T3F-87501-250	303	370	450	250	6SE0180-2BD33-7AA7	H
2T3F-87501-315	378	460	560	315	6SE0180-2BD34-6AA7	H
2T3F-87501-400	516	640	700	400	6SE0180-2BD36-3AA7	H
2T3F-87501-500	606	730	900	500	6SE0180-2BD37-3AA7	H
2T3F-87501-560	677	820	980	560	6SE0180-2BD38-2AA7	H
2T3F-87501-630	767	920	1100	630	6SE0180-2BD38-8AA7	H
2T3F-87501-710	849	1030	1230	710	6SE0180-2BD41-0AA7	H
2T3F-87501-800	944	1150	1380	800	6SE0180-2BD41-1AA7	H

Notice:

The 500 V, 12-pulse, air-cooled version of the SINAMICS G180 cabinet unit is normally operated on a three-winding transformer. This transformer can be ordered as a separate item on request. This version of the cabinet unit could also operate on a shift transformer.

Please ask your Siemens contact person for further advice.

¹⁾ Short-time current for 60 s every 10 minutes.

²⁾ Rated power of a typical 2- to 6-pole standard motor.

Selection and ordering data
690 V, 6-pulse

SINAMICS G180 cabinet unit (400 to 690 V 3 AC TN/TT system, 50 to 60 Hz)

Converter type	Connected load kVA	Output		Type rating ²⁾ kW	SINAMICS G180 cabinet units, air-cooled Article No.	Version (see options)
		Continuous current A	Short-time current ¹⁾ A			
2T3A-87601-250	312	270	320	250	6SE0180-1BG33-2AA7	I
2T3A-87601-315	391	340	410	315	6SE0180-1BG33-6AA7	I
2T3A-87601-400	502	440	510	400	6SE0180-1BG34-2AA7	J
2T3A-87601-500	608	530	640	500	6SE0180-1BG35-2AA7	K
2T3A-87601-560	676	590	710	560	6SE0180-1BG35-7AA7	K
2T3A-87601-630	764	660	800	630	6SE0180-1BG36-4AA7	K
2T3A-87601-710	854	750	890	710	6SE0180-1BG37-1AA7	K
2T3A-87601-800	956	840	980	800	6SE0180-1BG37-7AA7	K
2T3A-87601-909	1078	950	1060	900	6SE0180-1BG41-0AA7	K
2T3A-87601-910	1165	1040	1130	1000	6SE0180-1BG41-1AA7	K
2T3A-87602-912	1410	1260	1520	1200	6SE0180-1CG41-2AA7	K
2T3A-87602-913	1603	1430	1700	1300	6SE0180-1CG41-3AA7	K
2T3A-87602-915	1795	1600	1870	1500	6SE0180-1CG41-5AA7	K
2T3A-87602-917	2030	1810	2020	1700	6SE0180-1CG41-7AA7	K
2T3A-87602-919	2220	1980	2150	1900	6SE0180-1CG42-0AA7	K

SINAMICS G180 cabinet unit (400 to 690 V 3 AC IT system, 50 to 60 Hz)

Converter type	Connected load kVA	Output		Type rating ²⁾ kW	SINAMICS G180 cabinet units, air-cooled Article No.	Version (see options)
		Continuous current A	Short-time current ¹⁾ A			
2T3A-87601-250	312	270	320	250	6SE0180-1BH33-2AA7	L
2T3A-87601-315	391	340	410	315	6SE0180-1BH33-6AA7	L
2T3A-87601-400	502	440	510	400	6SE0180-1BH34-2AA7	M
2T3A-87601-500	608	530	640	500	6SE0180-1BH35-2AA7	N
2T3A-87601-560	676	590	710	560	6SE0180-1BH35-7AA7	N
2T3A-87601-630	764	660	800	630	6SE0180-1BH36-4AA7	N
2T3A-87601-710	854	750	890	710	6SE0180-1BH37-1AA7	N
2T3A-87601-800	956	840	980	800	6SE0180-1BH37-7AA7	N
2T3A-87601-909	1078	950	1060	900	6SE0180-1BH41-0AA7	N
2T3A-87601-910	1165	1040	1130	1000	6SE0180-1BH41-1AA7	N
2T3A-87602-912	1410	1260	1520	1200	6SE0180-1CH41-2AA7	N
2T3A-87602-913	1603	1430	1700	1300	6SE0180-1CH41-3AA7	N
2T3A-87602-915	1795	1600	1870	1500	6SE0180-1CH41-5AA7	N
2T3A-87602-917	2030	1810	2020	1700	6SE0180-1CH41-7AA7	N
2T3A-87602-919	2220	1980	2150	1900	6SE0180-1CH42-0AA7	N

¹⁾ Short-time current for 60 s every 10 minutes.

²⁾ Rated power of a typical 2- to 6-pole standard motor.

SINAMICS G180

SINAMICS G180 cabinet units

SINAMICS G180 cabinet units air-cooled

Selection and ordering data

690 V, 12-pulse

SINAMICS G180 cabinet unit (2 × 400 to 690 V 3 AC IT system, 50 to 60 Hz)

Converter type	Connected load kVA	Output		Type rating ²⁾ kW	SINAMICS G180 cabinet units, air-cooled Article No.	Version (see options)
		Continuous current A	Short-time current ¹⁾ A			
2T3F-87601-250	311	270	320	250	6SE0180-2BH33-2AA7	O
2T3F-87601-315	392	340	410	315	6SE0180-2BH33-6AA7	O
2T3F-87601-400	502	440	510	400	6SE0180-2BH34-2AA7	O
2T3F-87601-500	600	530	640	500	6SE0180-2BH35-2AA7	O
2T3F-87601-560	667	590	710	560	6SE0180-2BH35-7AA7	O
2T3F-87601-630	755	660	800	630	6SE0180-2BH36-4AA7	O
2T3F-87601-710	848	750	890	710	6SE0180-2BH37-1AA7	O
2T3F-87601-800	949	840	980	800	6SE0180-2BH37-7AA7	O
2T3F-87601-909	1071	950	1060	900	6SE0180-2BH41-0AA7	O
2T3F-87601-910	1159	1040	1130	1000	6SE0180-2BH41-1AA7	O
2T3F-87602-912	1405	1260	1520	1200	6SE0180-2CH41-2AA7	O
2T3F-87602-913	1597	1430	1700	1300	6SE0180-2CH41-3AA7	O
2T3F-87602-915	1781	1600	1870	1500	6SE0180-2CH41-5AA7	O
2T3F-87602-917	2010	1810	2020	1700	6SE0180-2CH41-7AA7	O
2T3F-87602-919	2194	1980	2150	1900	6SE0180-2CH42-0AA7	O
2T3F-87603-920	2369	2140	2540	2000	6SE0180-2DH42-2AA7	O
2T3F-87603-923	2648	2400	2800	2300	6SE0180-2DH42-4AA7	O
2T3F-87603-926	2983	2710	3030	2600	6SE0180-2DH42-7AA7	O
2T3F-87603-929	3272	2970	3230	2900	6SE0180-2DH43-0AA7	O
2T3F-87604-931	3516	3200	3730	3100	6SE0180-2EH43-2AA7	O
2T3F-87604-935	3956	3610	4030	3500	6SE0180-2EH43-6AA7	O
2T3F-87604-939	4336	3960	4300	3900	6SE0180-2EH44-0AA7	O

Notice:

The 690 V, 12-pulse, air-cooled version of the SINAMICS G180 cabinet unit is normally operated on a three-winding transformer. This transformer can be ordered as a separate item on request. This version of the cabinet unit could also operate on a shift transformer.

Please ask your Siemens contact person for further advice.

690 V, 18-pulse

SINAMICS G180 cabinet unit (3 × 400 to 690 V 3 AC IT system, 50 to 60 Hz)

Converter type	Connected load kVA	Output		Type rating ²⁾ kW	SINAMICS G180 cabinet units, air-cooled Article No.	Version (see options)
		Continuous current A	Short-time current ¹⁾ A			
2T3K-87603-920	2369	2140	2540	2000	6SE0180-3DH42-2AA7	O
2T3K-87603-923	2648	2400	2800	2300	6SE0180-3DH42-4AA7	O
2T3K-87603-926	2983	2710	3030	2600	6SE0180-3DH42-7AA7	O
2T3K-87603-929	3272	2970	3230	2900	6SE0180-3DH43-0AA7	O
2T3K-87606-941	4692	4290	5100	4100	6SE0180-3HH44-3AA7	O
2T3K-87606-947	5244	4800	5610	4700	6SE0180-3HH44-8AA7	O
2T3K-87606-953	5916	5420	6040	5300	6SE0180-3HH45-4AA7	O
2T3K-87606-958	6482	5940	6450	5800	6SE0180-3HH46-0AA7	O

¹⁾ Short-time current for 60 s every 10 minutes.

²⁾ Rated power of a typical 2- to 6-pole standard motor.

Selection and ordering data

690 V, 24-pulse

SINAMICS G180 cabinet unit (4 × 400 to 690 V 3 AC IT system, 50 to 60 Hz)

Converter type	Connected load kVA	Output		Type rating ²⁾ kW	SINAMICS G180 cabinet units, air-cooled Article No.	Version (see options)
		Continuous current A	Short-time current ¹⁾ A			
2T3L-87602-912	1405	1260	1520	1200	6SE0180-4CH41-2AA7	O
2T3L-87602-913	1597	1430	1700	1300	6SE0180-4CH41-3AA7	O
2T3L-87602-915	1781	1600	1870	1500	6SE0180-4CH41-5AA7	O
2T3L-87602-917	2010	1810	2020	1700	6SE0180-4CH41-7AA7	O
2T3L-87602-919	2194	1980	2150	1900	6SE0180-4CH42-0AA7	O
2T3L-87604-931	3516	3200	3730	3100	6SE0180-4EH43-2AA7	O
2T3L-87604-935	3956	3610	4030	3500	6SE0180-4EH43-6AA7	O
2T3L-87604-939	4336	3960	4300	3900	6SE0180-4EH44-0AA7	O
2T3L-87606-941	4692	4290	5100	4100	6SE0180-4HH44-3AA7	O
2T3L-87606-947	5244	4800	5610	4700	6SE0180-4HH44-8AA7	O
2T3L-87606-953	5916	5420	6040	5300	6SE0180-4HH45-4AA7	O
2T3L-87606-958	6482	5940	6450	5800	6SE0180-4HH46-0AA7	O

¹⁾ Short-time current for 60 s every 10 minutes.

²⁾ Rated power of a typical 2- to 6-pole standard motor.

SINAMICS G180

SINAMICS G180 cabinet units

SINAMICS G180 cabinet units air-cooled

Selection and ordering data

Article number code

Position of Article No.	1	2	3	4	5	6	7	8	9	10	11	12	13	14	15	16	
SINAMICS G180 cabinet units	6	S	E	0	1	0	-					.	-	.	A	A	.
Mechanical design																	
Air-cooled cabinet unit						8											
Line harmonics																	
6-pulse								1									
12-pulse								2									
18-pulse								3									
24-pulse								4									
Number of parallel connected systems																	
Single device with system management								B									
Multiple device with 2 parallel circuits								C									
Multiple device with 3 parallel circuits								D									
Multiple device with 4 parallel circuits								E									
Multiple device with 5 parallel circuits								G									
Multiple device with 6 parallel circuits								H									
Multiple device with 7 parallel circuits								J									
Supply voltage																	
230 ... 415 V 3 AC TN/TT, 50 ... 60 Hz								A									
230 ... 415 V 3 AC IT, 50 ... 60 Hz								B									
230 ... 500 V 3 AC TN/TT, 50 ... 60 Hz								C									
230 ... 500 V 3 AC IT, 50 ... 60 Hz								D									
400 ... 690 V 3 AC TN/TT, 50 ... 60 Hz								G									
400 ... 690 V 3 AC IT, 50 ... 60 Hz								H									
Code for output current																	
<u>Multiplier for current value</u>																	
0.1											1						
1											2						
10											3						
100											4						
<u>Current value</u>													.		.		
Version/release number																	
Version/release number T7																7	

3

SINAMICS G180

SINAMICS G180 cabinet units

SINAMICS G180 cabinet units
air-cooled

Selection and ordering data

Number code for *converter type*

Position of <i>converter type</i> No.	1	2	3	4	5	6	7	8	9	10	11	12
SINAMICS G180 cabinet units	2	T	.	.	-	-	.	.
Degree of protection												
IP21			3									
IP54			6									
IP55			7									
Different degree of protection			9									
Number of pulses in the input												
6-pulse input				A								
12-pulse input				F								
18-pulse input				K								
24-pulse input				L								
Mechanical design												
Air-cooled cabinet unit					8							
Modification status												
Modification status 7						7						
Line voltage												
400 V unit							4					
500 V unit							5					
690 V unit							6					
Number of parallel line-converter systems												
Single device without system management									0			
Number of parallel machine-converter systems												
Single device without system management									0			
Single device with system management									1			
Multiple device with corresponding number of parallel systems and system management units									2			
									...			
									7			
Achievable type rating in kW with continuous output current												
If the 10th position of the type number is "9", the other two digits show the output in kW × 100.										.	.	.

3

SINAMICS G180

SINAMICS G180 cabinet units

SINAMICS G180 cabinet units air-cooled

Options

The following tables provide an overview of the options and their availability for SINAMICS G180 cabinet units with a supply voltage of 400 V, 500 V or 690 V. (For details, see catalog chapter 4 "Option descriptions".)

Option text	Additional ordering data -Z with order code and, if necessary, with plain text specification	Air-cooled versions of SINAMICS G180 cabinet units														
		400 V					500 V					690 V				
		Pulse number 6					Pulse number 12					Pulse number 6				
Version – see selection and ordering data																
A B C D E F G H I J K L M N O																
Line voltages																
Line voltage 380 V, 50 Hz	V70	✓	✓	✓	✓	✓	✓	✓	✓	–	–	–	–	–	–	–
Line voltage 400 V, 50 Hz	V71	□	□	□	□	□	✓	✓	✓	✓	✓	✓	✓	✓	✓	✓
Line voltage 415 V, 50 Hz	V72	✓	✓	✓	✓	✓	✓	✓	✓	✓	✓	✓	✓	✓	✓	✓
Line voltage 500 V, 50 Hz	V73	–	–	–	–	–	–	–	–	–	–	–	–	–	–	–
Line voltage 660 V, 50 Hz	V74	–	–	–	–	–	–	–	–	–	–	–	–	–	–	–
Line voltage 690 V, 50 Hz	V75	–	–	–	–	–	–	–	–	–	–	–	–	–	–	–
Line voltage 440 V, 60 Hz	V76	–	–	–	–	–	–	–	–	–	–	–	–	–	–	–
Line voltage 460 V, 60 Hz	V77	–	–	–	–	–	–	–	–	–	–	–	–	–	–	–
Line voltage 480 V, 60 Hz	V78	–	–	–	–	–	–	–	–	–	–	–	–	–	–	–
Line voltage 600 V, 60 Hz	V79	–	–	–	–	–	–	–	–	–	–	–	–	–	–	–
Line voltage 660 V, 60 Hz	V80	–	–	–	–	–	–	–	–	–	–	–	–	–	–	–
Special line voltage; please specify voltage	Y70 • and identification code	✓ ¹⁾	✓ ¹⁾	✓ ¹⁾	✓ ¹⁾	✓ ¹⁾	✓ ²⁾	✓ ²⁾	✓ ²⁾	✓ ³⁾	✓ ³⁾	✓ ³⁾	✓ ³⁾	✓ ³⁾	✓ ³⁾	✓ ³⁾
Additional cabinet																
400 mm	H90	✓	✓	✓	✓	✓	✓	✓	✓	✓	✓	✓	✓	✓	✓	✓
600 mm	H91	✓	✓	✓	✓	✓	✓	✓	✓	✓	✓	✓	✓	✓	✓	✓
800 mm	H92	✓	✓	✓	✓	✓	✓	✓	✓	✓	✓	✓	✓	✓	✓	✓
1000 mm	H93	✓	✓	✓	✓	✓	✓	✓	✓	✓	✓	✓	✓	✓	✓	✓
1200 mm	H94	✓	✓	✓	✓	✓	✓	✓	✓	✓	✓	✓	✓	✓	✓	✓
External auxiliary power supply																
Connection for 230 V 1 AC 50 Hz auxiliary voltage provided by customer	C36	✓	✓	✓	✓	✓	✓	✓	✓	✓	✓	✓	✓	✓	✓	✓
Connection for 400 V 3 AC 50 Hz auxiliary voltage provided by customer	C38	✓	✓	✓	✓	✓	✓	✓	✓	✓	✓	✓	✓	✓	✓	✓
Connection for 500 V 3 AC 50 Hz auxiliary voltage provided by customer	C43	✓	✓	✓	✓	✓	✓	✓	✓	✓	✓	✓	✓	✓	✓	✓
Connection for 690 V 3 AC 50 Hz auxiliary voltage provided by customer	C48	✓	✓	✓	✓	✓	✓	✓	✓	✓	✓	✓	✓	✓	✓	✓
Connection for other 3 AC voltage provided by customer; please specify voltage	Y36 • and identification code	✓	✓	✓	✓	✓	✓	✓	✓	✓	✓	✓	✓	✓	✓	✓
External control voltage supply																
Connection for 230 V 1 AC 50 Hz control voltage provided by customer, without UPS backup	C56	✓	✓	✓	✓	✓	✓	✓	✓	✓	✓	✓	✓	✓	✓	✓
Connection for 230 V 1 AC 50 Hz control voltage provided by customer, with UPS backup	C57	✓	✓	✓	✓	✓	✓	✓	✓	✓	✓	✓	✓	✓	✓	✓
Connection for different 1 AC control voltage (47 to 63 Hz) provided by customer; please specify voltage	Y55 • and identification code	✓	✓	✓	✓	✓	✓	✓	✓	✓	✓	✓	✓	✓	✓	✓
Other option																
Board for mains supply backup	E85	✓	✓	✓	✓	✓	✓	✓	✓	✓	✓	✓	✓	✓	✓	✓
DC link connected to terminals	N39	□	□	□	□	□	□	□	□	□	□	□	□	□	□	□
RFI suppression filter																
RFI suppression filter, category C2 or C3 (class A)	L00	□	□	□	□	–	✓	✓	–	□	□	□	✓	✓	✓	–
Line Harmonics Filter																
Line Harmonics Filter for 50 Hz line frequency	L03	H92 ₆₎	H92 ₆₎	H93 ₆₎	✓ ⁵⁾	–	H93 ₆₎	✓ ⁵⁾	–	H92 ₆₎	H93 ₆₎	✓ ⁵⁾	H92 ₆₎	H93 ₆₎	✓ ⁵⁾	–
Line Harmonics Filter for 60 Hz line frequency	L04	H92 ₆₎	H92 ₆₎	H93 ₆₎	✓ ⁵⁾	–	H93 ₆₎	✓ ⁵⁾	–	H92 ₆₎	H93 ₆₎	✓ ⁵⁾	H92 ₆₎	H93 ₆₎	✓ ⁵⁾	–

For legends and footnotes, see Page 3/40.

SINAMICS G180

SINAMICS G180 cabinet units

SINAMICS G180 cabinet units
air-cooled

Options

Option text	Additional ordering data -Z with order code and, if necessary, with plain text specification	Air-cooled versions of SINAMICS G180 cabinet units															
		400 V					500 V					690 V					
		Pulse number 6					12					6					
Version – see selection and ordering data																	
A B C D E F G H I J K L M N O																	
Output filter																	
Strengthened dv/dt output filter for max. 250/300 m (type-dependent). Design for longer motor cables available on request	L10	□	□	□	□	□	□	□	□	□	✓ ⁴⁾	✓ ⁴⁾	✓ ⁴⁾	✓ ⁴⁾	✓ ⁴⁾	✓ ⁴⁾	✓ ⁴⁾
Sine-wave filter integrated in control cabinet or additional cabinet, suitable for motor frequencies of ≤ 75 Hz, voltage drop of approximately 10 % of line voltage	L14	H91 ₆₎	H92 ₆₎	H92 ₆₎	H92 ₆₎	✓ ⁵⁾	H91 ₆₎	H92 ₆₎	✓ ⁵⁾	–	–	–	–	–	–	–	
Sine-wave filter integrated in control cabinet or additional cabinet, suitable for motor frequencies of ≤ 60 Hz, voltage drop of approximately 10 % of line voltage	L15	–	–	–	–	–	–	–	–	✓ ⁵⁾	✓ ⁵⁾	✓ ⁵⁾	✓ ⁵⁾	✓ ⁵⁾	✓ ⁵⁾	✓ ⁵⁾	
Standard accessories packages																	
Peripheral board 4 (G05) instead of peripheral board 2 (G03) (only in conjunction with package S01, S02, S03, S04, S08, S09, S11, S12)	G08	✓	✓	✓	✓	✓	✓	✓	✓	✓	✓	✓	✓	✓	✓	✓	
Accessories package S01 with main switch, line contactor, EMERGENCY OFF pushbutton and safety relay, board G03, local/remote switch	S01	✓	✓	✓	✓	✓	✓	✓	✓	✓	✓	✓	✓	✓	✓	✓	
Accessories package S02 with circuit breaker, line contactor, EMERGENCY OFF pushbutton and safety relay, board G03, local/remote switch	S02	✓	✓	✓	✓	✓	✓	✓	✓	✓	✓	✓	✓	✓	✓	✓	
Accessories package with main switch, line contactor, board G03, local/remote switch	S03	✓	✓	✓	✓	✓	✓	✓	✓	✓	✓	✓	✓	✓	✓	✓	
Accessories package with circuit breaker, line contactor, board G03, local/remote switch	S04	✓	✓	✓	✓	✓	✓	✓	✓	✓	✓	✓	✓	✓	✓	✓	
Accessories package with main switch, line contactor, ATEX certified PTC monitoring relay, RCU box connection	S06	✓	✓	✓	✓	✓	✓	✓	✓	✓	✓	✓	✓	✓	✓	✓	
Bypass for smooth line synchronization (soft start function) incl. line-side main switch and contactors at the converter output and in bypass	S08	H92 ₆₎	H92 ₆₎	H92 ₆₎	H92 ₆₎	✓ ⁵⁾	H92 ₆₎	H92 ₆₎	✓ ⁵⁾	H92 ₆₎	H92 ₆₎	H92 ₆₎	✓ ⁵⁾	✓ ⁵⁾	✓ ⁵⁾	✓ ⁵⁾	
Bypass for smooth line synchronization (soft start function) incl. line-side circuit breaker and contactors at the converter output and in bypass	S09	H92 ₆₎	H92 ₆₎	H92 ₆₎	H92 ₆₎	✓ ⁵⁾	H92 ₆₎	H92 ₆₎	✓ ⁵⁾	H92 ₆₎	H92 ₆₎	H92 ₆₎	✓ ⁵⁾	✓ ⁵⁾	✓ ⁵⁾	✓ ⁵⁾	
Accessories package S11 with line-side main switch, board G03, local/remote switch	S11	✓	✓	✓	✓	✓	✓	✓	✓	✓	✓	✓	✓	✓	✓	✓	
Accessories package S12 with line-side circuit breaker, board G03, local/remote switch	S12	✓	✓	✓	✓	✓	✓	✓	✓	✓	✓	✓	✓	✓	✓	✓	
Bypass with line-side main switch, contactors at converter output and in bypass, switchover between manual and automatic, local/remote switch	S21	H91 ₆₎	H91 ₆₎	H91 ₆₎	H91 ₆₎	✓ ⁵⁾	H91 ₆₎	H91 ₆₎	✓ ⁵⁾	H91 ₆₎	H91 ₆₎	H91 ₆₎	✓ ⁵⁾	✓ ⁵⁾	✓ ⁵⁾	✓ ⁵⁾	
Bypass with line-side circuit breaker, contactors at converter output and in bypass, switchover between manual and automatic, local/remote switch	S22	H91 ₆₎	H91 ₆₎	H91 ₆₎	H91 ₆₎	✓ ⁵⁾	H91 ₆₎	H91 ₆₎	✓ ⁵⁾	H91 ₆₎	H91 ₆₎	H91 ₆₎	✓ ⁵⁾	✓ ⁵⁾	✓ ⁵⁾	✓ ⁵⁾	
Bypass with line-side main switch, contactors at converter output and in bypass, EMERGENCY OFF safety relay, switchover between manual and automatic, local/remote switch	S23	H91 ₆₎	H91 ₆₎	H91 ₆₎	H91 ₆₎	✓ ⁵⁾	H91 ₆₎	H91 ₆₎	✓ ⁵⁾	H91 ₆₎	H91 ₆₎	H91 ₆₎	✓ ⁵⁾	✓ ⁵⁾	✓ ⁵⁾	✓ ⁵⁾	
Bypass with line-side circuit breaker, contactors at converter output and in bypass, EMERGENCY OFF safety relay, switchover between manual and automatic, local/remote switch	S24	H91 ₆₎	H91 ₆₎	H91 ₆₎	H91 ₆₎	✓ ⁵⁾	H91 ₆₎	H91 ₆₎	✓ ⁵⁾	H91 ₆₎	H91 ₆₎	H91 ₆₎	✓ ⁵⁾	✓ ⁵⁾	✓ ⁵⁾	✓ ⁵⁾	

For legends and footnotes, see Page 3/40.

SINAMICS G180

SINAMICS G180 cabinet units

SINAMICS G180 cabinet units air-cooled

Options

Option text	Additional ordering data -Z with order code and, if necessary, with plain text specification	Air-cooled versions of SINAMICS G180 cabinet units														
		400 V					500 V					690 V				
		Pulse number 6					Pulse number 12					Pulse number 6				
		A	B	C	D	E	F	G	H	I	J	K	L	M	N	O
Standard accessories packages (continued)																
NAMUR accessories package with Test/Normal operation switch, option G05, terminal strip compliant with NAMUR NE37 (without main switch/main contactor)	S31	✓	✓	✓	✓	✓	✓	✓	✓	✓	✓	✓	✓	✓	✓	✓
NAMUR accessories package with Test/Normal operation switch, main switch, line contactor, option G05, terminal strip compliant with NAMUR NE37	S32	✓	✓	✓	✓	✓	✓	✓	✓	✓	✓	✓	✓	✓	✓	✓
Braking chopper																
Braking chopper integrated into converter (braking resistor is not included and must be ordered separately)	L72	✓	✓	✓	✓	✓	✓	✓	✓	✓	✓	✓	✓	✓	✓	✓
Insulation monitoring																
Integrated insulation monitoring system for operation on secondary side of unit transformer in an IT system	L87	-	-	-	-	□	-	-	□	-	-	-	-	-	-	□
ATEX certified PTC monitoring relay																
ATEX certified PTC monitoring relay without storage for motor temperature prewarning	L80	✓	✓	✓	✓	✓	✓	✓	✓	✓	✓	✓	✓	✓	✓	✓
ATEX certified PTC monitoring relay with storage for motor temperature trip	L81	✓	✓	✓	✓	✓	✓	✓	✓	✓	✓	✓	✓	✓	✓	✓
ATEX certified PTC monitoring relay without storage for transformer temperature prewarning	L82	✓	✓	✓	✓	✓	✓	✓	✓	✓	✓	✓	✓	✓	✓	✓
ATEX certified PTC monitoring relay with storage for transformer temperature trip	L83	✓	✓	✓	✓	✓	✓	✓	✓	✓	✓	✓	✓	✓	✓	✓
ATEX certified PTC monitoring relay for other PTC thermistor monitoring functions	Y80 • and identification code	✓	✓	✓	✓	✓	✓	✓	✓	✓	✓	✓	✓	✓	✓	✓
Pt100 evaluation unit																
Pt100 evaluation unit for motor winding temperature, integrated in control cabinet for monitoring of 3 × Pt100 or 3 × KTY83/84 sensors	L90	✓	✓	✓	✓	✓	✓	✓	✓	✓	✓	✓	✓	✓	✓	✓
Pt100 evaluation unit for motor bearing temperature, integrated in control cabinet for monitoring of 2 × Pt100 or 2 × KTY83/84 sensors	L91	✓	✓	✓	✓	✓	✓	✓	✓	✓	✓	✓	✓	✓	✓	✓
Pt100 evaluation unit for motor winding temperature, integrated in cabinet for monitoring 3 × Pt100 sensors; plus an analog output 0 to 10 V or 0(4) to 20 mA connected to terminals for the hottest winding temperature	L92	✓	✓	✓	✓	✓	✓	✓	✓	✓	✓	✓	✓	✓	✓	✓
Pt100 evaluation unit for motor bearing temperature, integrated in cabinet for monitoring 2 × Pt100 sensors or 2 × KTY83/84 sensors; plus two analog outputs 0 to 10 V or 0(4) to 20 mA connected to terminals for bearing temperature	L93	✓	✓	✓	✓	✓	✓	✓	✓	✓	✓	✓	✓	✓	✓	✓
Pt100 evaluation unit for motor winding and bearing temperatures, integrated in cabinet for monitoring 6 × Pt100 sensors; plus two analog outputs 0 to 10 V or 0(4) to 20 mA connected to terminals for the hottest winding and bearing temperatures	L94	✓	✓	✓	✓	✓	✓	✓	✓	✓	✓	✓	✓	✓	✓	✓
Pt100 evaluation unit for other temperature monitoring functions, integrated in cabinet for monitoring of 3 × Pt100 or 3 × KTY83/84 sensors	Y90 • and identification code	✓	✓	✓	✓	✓	✓	✓	✓	✓	✓	✓	✓	✓	✓	✓
Pt100 evaluation unit for other temperature monitoring functions, integrated in cabinet for monitoring 6 × Pt100 sensors; plus two analog outputs 0 to 10 V or 0(4) to 20 mA connected to terminals	Y94 • and identification code	✓	✓	✓	✓	✓	✓	✓	✓	✓	✓	✓	✓	✓	✓	✓

For legends and footnotes, see Page 3/40.

Options

Option text	Additional ordering data -Z with order code and, if necessary, with plain text specification	Air-cooled versions of SINAMICS G180 cabinet units															
		400 V					500 V					690 V					
		Pulse number															
		6					12					6					12 18 24
		Version – see selection and ordering data															
		A	B	C	D	E	F	G	H	I	J	K	L	M	N	O	
Degrees of protection																	
Increased degree of protection IP41 for air-cooled cabinet units and systems	M41	✓	✓	✓	✓	✓	✓	✓	✓	✓	✓	✓	✓	✓	✓	✓	
Increased degree of protection IP43 for air-cooled cabinet units and systems	M43	✓	✓	✓	✓	✓	✓	✓	✓	✓	✓	✓	✓	✓	✓	✓	
Increased degree of protection IP54 for air-cooled cabinet units and systems; not suitable for outdoor applications	M54	✓	✓	-	-	-	✓	-	-	✓	✓	-	-	-	-	-	
Air flange for connection to customer's exhaust air systems (air outlet IP00)	M63	✓	✓	✓	✓	✓	✓	✓	✓	✓	✓	✓	✓	✓	✓	✓	
Cabinet options																	
Control cabinet base, welded and suitable for use with transport rollers, in RAL 7022, h = 200 mm	M05	✓	✓	✓	✓	✓	✓	✓	✓	✓	✓	✓	✓	✓	✓	✓	
Control cabinet base, standard version in RAL 9005, h = 100 mm	M06	✓	✓	✓	✓	✓	✓	✓	✓	✓	✓	✓	✓	✓	✓	✓	
Control cabinet base, standard version in RAL 9005, h = 200 mm	M07	✓	✓	✓	✓	✓	✓	✓	✓	✓	✓	✓	✓	✓	✓	✓	
Cable entry from the top: Power cable	M13	✓ ⁽⁵⁾	✓ ⁽⁵⁾	✓ ⁽⁵⁾	✓ ⁽⁵⁾	✓ ⁽⁵⁾	✓ ⁽⁵⁾	✓ ⁽⁵⁾	✓ ⁽⁵⁾	✓ ⁽⁵⁾	✓ ⁽⁵⁾	✓ ⁽⁵⁾	✓ ⁽⁵⁾	✓ ⁽⁵⁾	✓ ⁽⁵⁾	✓ ⁽⁵⁾	
Door opening angle 180°	M17	✓	✓	✓	✓	✓	✓	✓	✓	✓	✓	✓	✓	✓	✓	✓	
Window in door for viewing internal display	M19	✓	✓	✓	✓	✓	✓	✓	✓	✓	✓	✓	✓	✓	✓	✓	
Door hinge on left	M28	✓	✓	✓	✓	✓	✓	✓	✓	✓	✓	✓	✓	✓	✓	✓	
Cable entry from the top: Control cables	M34	✓ ⁽⁵⁾	✓ ⁽⁵⁾	✓ ⁽⁵⁾	✓ ⁽⁵⁾	✓ ⁽⁵⁾	✓ ⁽⁵⁾	✓ ⁽⁵⁾	✓ ⁽⁵⁾	✓ ⁽⁵⁾	✓ ⁽⁵⁾	✓ ⁽⁵⁾	✓ ⁽⁵⁾	✓ ⁽⁵⁾	✓ ⁽⁵⁾	✓ ⁽⁵⁾	
Comfort-grip handle with double-bit key lock	M38	✓	✓	✓	✓	✓	✓	✓	✓	✓	✓	✓	✓	✓	✓	✓	
Comfort-grip handle with integrated pushbutton	M39	✓	✓	✓	✓	✓	✓	✓	✓	✓	✓	✓	✓	✓	✓	✓	
Comfort-grip handle with cylinder lock	M40	✓	✓	✓	✓	✓	✓	✓	✓	✓	✓	✓	✓	✓	✓	✓	
Air supply via cable floor. No filter mats required in door	M59	✓	✓	✓	✓	✓	✓	✓	✓	✓	✓	✓	✓	✓	✓	✓	
Cable entry from the top: Motor cables	M78	✓ ⁽⁵⁾	✓ ⁽⁵⁾	✓ ⁽⁵⁾	✓ ⁽⁵⁾	✓ ⁽⁵⁾	✓ ⁽⁵⁾	✓ ⁽⁵⁾	✓ ⁽⁵⁾	✓ ⁽⁵⁾	✓ ⁽⁵⁾	✓ ⁽⁵⁾	✓ ⁽⁵⁾	✓ ⁽⁵⁾	✓ ⁽⁵⁾	✓ ⁽⁵⁾	
Special control cabinet paint color: Please specify RAL	Y09 • and identification code	✓	✓	✓	✓	✓	✓	✓	✓	✓	✓	✓	✓	✓	✓	✓	
Window in door for viewing internal components	Y19 • and identification code	✓	✓	✓	✓	✓	✓	✓	✓	✓	✓	✓	✓	✓	✓	✓	
Control elements and display instruments in control cabinet door																	
SENTRON PAC3220 power monitoring device (without current transformer)	G10	✓	✓	✓	✓	✓	✓	✓	✓	✓	✓	✓	✓	✓	✓	✓	
SENTRON PAC3220 power monitoring device (with current transformer)	G11	✓	✓	✓	✓	✓	✓	✓	✓	✓	✓	✓	✓	✓	✓	✓	
PROFIBUS expansion module for option G10 or G11 (SENTRON PAC3220 power monitoring device)	G12	✓	✓	✓	✓	✓	✓	✓	✓	✓	✓	✓	✓	✓	✓	✓	
External 4-line operator panel, supplied separately packed	K14	✓	✓	✓	✓	✓	✓	✓	✓	✓	✓	✓	✓	✓	✓	✓	
External 4-line operator panel integrated in control cabinet door	K15	□	□	□	□	□	□	□	□	□	□	□	□	□	□	□	
Selector switch in form of key-operated switch	K37	✓	✓	✓	✓	✓	✓	✓	✓	✓	✓	✓	✓	✓	✓	✓	
Accessories																	
Grounding socket outlet 230 V, 50 Hz, 10 A, in control cabinet with 30 mA ground-fault circuit interrupter, external incoming supply	L48	✓	✓	✓	✓	✓	✓	✓	✓	✓	✓	✓	✓	✓	✓	✓	
Socket outlet 230 V, 50 Hz, 1 A, in control cabinet with 30 mA ground-fault circuit interrupter, supplied internally	L49	✓	✓	✓	✓	✓	✓	✓	✓	✓	✓	✓	✓	✓	✓	✓	

SINAMICS G180

SINAMICS G180 cabinet units

SINAMICS G180 cabinet units air-cooled

Options

Option text	Additional ordering data -Z with order code and, if necessary, with plain text specification	Air-cooled versions of SINAMICS G180 cabinet units														
		400 V					500 V					690 V				
		Pulse number					Pulse number					Pulse number				
		6		12	6		12	6		12	6		12	18	24	
		Version – see selection and ordering data														
		A	B	C	D	E	F	G	H	I	J	K	L	M	N	O
Accessories (continued)																
Magnetically attached cabinet light and door contact switch	L50	✓	✓	✓	✓	✓	✓	✓	✓	✓	✓	✓	✓	✓	✓	✓
Cabinet heater to protect against condensation and/or for operation with supply air temperature of -5 °C or below	L55	✓	✓	✓	✓	✓	✓	✓	✓	✓	✓	✓	✓	✓	✓	✓
Controlled outgoing feeder for motor heater, 230 V 1 AC, max. 4 kW	N35	✓	✓	✓	✓	✓	✓	✓	✓	✓	✓	✓	✓	✓	✓	✓
Controlled outgoing feeder for external motor fan, external fan voltage for 3 AC. Converter line voltage, max. 4 kW	N36	✓	✓	✓	✓	✓	✓	✓	✓	✓	✓	✓	✓	✓	✓	✓
Undervoltage release for main switch or circuit breaker; specify coil voltage	Y11 • and identification code	✓	✓	✓	✓	✓	✓	✓	✓	✓	✓	✓	✓	✓	✓	✓
Controlled outgoing feeder for auxiliary drive up to max. 4 kW; please specify type of drive, voltage, number of phases	Y98 • and identification code	✓	✓	✓	✓	✓	✓	✓	✓	✓	✓	✓	✓	✓	✓	✓
Marking of cable cores and items of equipment																
Dual marking of items of equipment	M96	✓	✓	✓	✓	✓	✓	✓	✓	✓	✓	✓	✓	✓	✓	✓
Cable marking	M94	✓	✓	✓	✓	✓	✓	✓	✓	✓	✓	✓	✓	✓	✓	✓
Wiring options																
Cross-section of cables installed inside cabinet 1.5 mm ²	M20	✓	✓	✓	✓	✓	✓	✓	✓	✓	✓	✓	✓	✓	✓	✓
Use of halogen-free cables inside cabinet	N50	✓	✓	✓	✓	✓	✓	✓	✓	✓	✓	✓	✓	✓	✓	✓
DC link connected to terminals	N39	□	□	□	□	□	□	□	□	□	□	□	□	□	□	□
Peripheral boards																
Peripheral board 1	G02	✓	✓	✓	✓	✓	✓	✓	✓	✓	✓	✓	✓	✓	✓	✓
Peripheral board 2	G03	✓	✓	✓	✓	✓	✓	✓	✓	✓	✓	✓	✓	✓	✓	✓
Peripheral board 3	G04	✓	✓	✓	✓	✓	✓	✓	✓	✓	✓	✓	✓	✓	✓	✓
Peripheral board 4	G05	✓	✓	✓	✓	✓	✓	✓	✓	✓	✓	✓	✓	✓	✓	✓
Additional boards for bus connection																
Board for PROFIBUS DP-V1	G01	✓	✓	✓	✓	✓	✓	✓	✓	✓	✓	✓	✓	✓	✓	✓
Board for PROFINET CU	G06	✓	✓	✓	✓	✓	✓	✓	✓	✓	✓	✓	✓	✓	✓	✓
Board for CANopen	G20	✓	✓	✓	✓	✓	✓	✓	✓	✓	✓	✓	✓	✓	✓	✓
Board for Modbus RTU	G22	✓	✓	✓	✓	✓	✓	✓	✓	✓	✓	✓	✓	✓	✓	✓
Board for Modbus TCP	G27	✓	✓	✓	✓	✓	✓	✓	✓	✓	✓	✓	✓	✓	✓	✓
Accessories for IMS																
USB PROFIBUS interface (supplied separately packed)	G13	✓	✓	✓	✓	✓	✓	✓	✓	✓	✓	✓	✓	✓	✓	✓
Ethernet-PROFIBUS gateway	G14	✓	✓	✓	✓	✓	✓	✓	✓	✓	✓	✓	✓	✓	✓	✓
Ethernet-to-RS232/485/422 converter (supplied separately packed)	G15	✓	✓	✓	✓	✓	✓	✓	✓	✓	✓	✓	✓	✓	✓	✓
USB cable A/B (supplied separately packed)	G16	✓	✓	✓	✓	✓	✓	✓	✓	✓	✓	✓	✓	✓	✓	✓
USB connector on front of control cabinet door	G18	✓	✓	✓	✓	✓	✓	✓	✓	✓	✓	✓	✓	✓	✓	✓
Extension of the liability for defects																
Extension of the liability for defects period by 12 months to a total of 24 months (2 years) after being delivered	Q80	✓	✓	✓	✓	✓	✓	✓	✓	✓	✓	✓	✓	✓	✓	✓
Extension of the liability for defects period by 18 months to a total of 30 months (2½ years) after being delivered	Q81	✓	✓	✓	✓	✓	✓	✓	✓	✓	✓	✓	✓	✓	✓	✓
Extension of the liability for defects period by 24 months to a total of 36 months (3 years) after being delivered	Q82	✓	✓	✓	✓	✓	✓	✓	✓	✓	✓	✓	✓	✓	✓	✓
Extension of the liability for defects period by 30 months to a total of 42 months (3½ years) after being delivered	Q83	✓	✓	✓	✓	✓	✓	✓	✓	✓	✓	✓	✓	✓	✓	✓

For legends and footnotes, see Page 3/40.

SINAMICS G180

SINAMICS G180 cabinet units

SINAMICS G180 cabinet units
air-cooled

Options

Option text	Additional ordering data -Z with order code and, if necessary, with plain text specification	Air-cooled versions of SINAMICS G180 cabinet units														
		400 V					500 V					690 V				
		Pulse number														
		6		12	6		12	6		12	6		12	18	24	
		Version – see selection and ordering data														
		A	B	C	D	E	F	G	H	I	J	K	L	M	N	O
Extension of the liability for defects (continued)																
Extension of the liability for defects period by 36 months to a total of 48 months (4 years) after being delivered	Q84	✓	✓	✓	✓	✓	✓	✓	✓	✓	✓	✓	✓	✓	✓	✓
Extension of the liability for defects period by 48 months to a total of 60 months (5 years) after being delivered	Q85	✓	✓	✓	✓	✓	✓	✓	✓	✓	✓	✓	✓	✓	✓	✓
Label for plant identification																
Cabinet designation TAG/ITEM number according to ordering data	T01	✓	✓	✓	✓	✓	✓	✓	✓	✓	✓	✓	✓	✓	✓	✓
Customized labels	Y33 • and identification code	✓	✓	✓	✓	✓	✓	✓	✓	✓	✓	✓	✓	✓	✓	✓
Ambient temperature for air-cooled converters																
45 °C ambient temperature (with corresponding derating)	V61	✓	✓	✓	✓	✓	✓	✓	✓	✓	✓	✓	✓	✓	✓	✓
50 °C ambient temperature (with corresponding derating)	V62	✓	✓	✓	✓	✓	✓	✓	✓	✓	✓	✓	✓	✓	✓	✓
Installation altitude																
Installation altitude max. 1500 m above sea level (with corresponding derating)	V86	✓	✓	✓	✓	✓	✓	✓	✓	✓	✓	✓	✓	✓	✓	✓
Installation altitude max. 2000 m above sea level (with corresponding derating)	V87	✓	✓	✓	✓	✓	✓	✓	✓	✓	✓	✓	✓	✓	✓	✓
Installation altitude max. 2500 m above sea level (with corresponding derating)	V88	✓	✓	✓	✓	✓	✓	✓	✓	✓	✓	✓	✓	✓	✓	✓
Installation altitude max. 3000 m above sea level (with corresponding derating)	V89	✓	✓	✓	✓	✓	✓	✓	✓	✓	✓	✓	✓	✓	✓	✓
Acceptance tests for converters																
Routine test under no-load conditions with customer present	F71	✓	✓	✓	✓	✓	✓	✓	✓	✓	✓	✓	✓	✓	✓	✓

3

SINAMICS G180

SINAMICS G180 cabinet units

SINAMICS G180 cabinet units air-cooled

Options

Option text	Additional ordering data -Z with order code and, if necessary, with plain text specification	Air-cooled versions of SINAMICS G180 cabinet units																
		400 V					500 V					690 V						
		Pulse number																
		6				12	6			12	6					12	18	24
		Version – see selection and ordering data																
		A	B	C	D	E	F	G	H	I	J	K	L	M	N	O		
Acceptance tests for converters (continued)																		
Advanced visual inspection and function test under rated load with 1MB motor (ordered with converter in package) with customer present	F85	✓	✓	✓	✓	✓	✓	✓	✓	✓	✓	✓	✓	✓	✓	✓	✓	✓
Supplementary documentation																		
Test sequence schedule	B48	✓	✓	✓	✓	✓	✓	✓	✓	✓	✓	✓	✓	✓	✓	✓	✓	✓
Production flowchart: Generated once	B43	✓	✓	✓	✓	✓	✓	✓	✓	✓	✓	✓	✓	✓	✓	✓	✓	✓
Production flowchart: Generated once per month	B45	✓	✓	✓	✓	✓	✓	✓	✓	✓	✓	✓	✓	✓	✓	✓	✓	✓
Converter display language																		
Display language Norwegian/English	T23	✓	✓	✓	✓	✓	✓	✓	✓	✓	✓	✓	✓	✓	✓	✓	✓	✓
Display language Swedish/English	T24	✓	✓	✓	✓	✓	✓	✓	✓	✓	✓	✓	✓	✓	✓	✓	✓	✓
Display language Czech/English	T25	✓	✓	✓	✓	✓	✓	✓	✓	✓	✓	✓	✓	✓	✓	✓	✓	✓
Display language Hungarian/English	T26	✓	✓	✓	✓	✓	✓	✓	✓	✓	✓	✓	✓	✓	✓	✓	✓	✓
Display language French/English	T58	✓	✓	✓	✓	✓	✓	✓	✓	✓	✓	✓	✓	✓	✓	✓	✓	✓
Display language Spanish/English	T60	✓	✓	✓	✓	✓	✓	✓	✓	✓	✓	✓	✓	✓	✓	✓	✓	✓
Display language German/English	T74	✓	✓	✓	✓	✓	✓	✓	✓	✓	✓	✓	✓	✓	✓	✓	✓	✓
Display language English/German	T76	✓	✓	✓	✓	✓	✓	✓	✓	✓	✓	✓	✓	✓	✓	✓	✓	✓
Display language Portuguese/English	T82	✓	✓	✓	✓	✓	✓	✓	✓	✓	✓	✓	✓	✓	✓	✓	✓	✓
Display language Russian/English	T85	✓	✓	✓	✓	✓	✓	✓	✓	✓	✓	✓	✓	✓	✓	✓	✓	✓
Display language Polish/English	T86	✓	✓	✓	✓	✓	✓	✓	✓	✓	✓	✓	✓	✓	✓	✓	✓	✓
Second display language other than English	Y14	✓	✓	✓	✓	✓	✓	✓	✓	✓	✓	✓	✓	✓	✓	✓	✓	✓
Converter documentation																		
Manual and set of diagrams in PDF format per e-mail, German/English	D01	□	□	□	□	□	□	□	□	□	□	□	□	□	□	□	□	□
Manual in PDF format, set of diagrams in DXF format per e-mail, German/English	D02	✓	✓	✓	✓	✓	✓	✓	✓	✓	✓	✓	✓	✓	✓	✓	✓	✓
Language of assembly and operating instructions																		
Different language for assembly and operating instructions	Y13 • and identification code	✓	✓	✓	✓	✓	✓	✓	✓	✓	✓	✓	✓	✓	✓	✓	✓	✓
Certifications																		
EAC certificate	U04	✓	✓	✓	✓	✓	✓	✓	✓	✓	✓	✓	✓	✓	✓	✓	✓	✓
Engineering (for description, see Page 4/33)																		
Mechanical system		✓	✓	✓	✓	✓	✓	✓	✓	✓	✓	✓	✓	✓	✓	✓	✓	✓
Parameterization		✓	✓	✓	✓	✓	✓	✓	✓	✓	✓	✓	✓	✓	✓	✓	✓	✓
Electrical (power output, control)		✓	✓	✓	✓	✓	✓	✓	✓	✓	✓	✓	✓	✓	✓	✓	✓	✓
Extended overvoltage range		– ⁷⁾	– ⁷⁾	– ⁷⁾	– ⁷⁾	– ⁷⁾	– ⁸⁾	– ⁸⁾	– ⁸⁾	✓	✓	✓	✓	✓	✓	✓	✓	
Test bay converter		✓	✓	✓	✓	✓	✓	✓	✓	✓	✓	✓	✓	✓	✓	✓	✓	✓
Special tests		✓	✓	✓	✓	✓	✓	✓	✓	✓	✓	✓	✓	✓	✓	✓	✓	✓
Special documentation		✓	✓	✓	✓	✓	✓	✓	✓	✓	✓	✓	✓	✓	✓	✓	✓	✓
Special version		✓	✓	✓	✓	✓	✓	✓	✓	✓	✓	✓	✓	✓	✓	✓	✓	✓

- ✓ Available
- Standard version
- Not possible
- This order code only determines the price of the version – additional plain text is required.

¹⁾ Voltage between 230 and 415 V.

²⁾ Voltage between 230 and 500 V.

³⁾ Voltage between 400 and 690 V.

⁴⁾ Please refer to technical data for cabinet dimensions.

⁵⁾ Please ask your Siemens contact person for the exact cabinet dimensions.

⁶⁾ Additional option included in the original option.

⁷⁾ 500 V cabinet units + the next-higher rating must be selected for the "Extended overvoltage range" function.

⁸⁾ 690 V cabinet units + the next-higher rating must be selected for the "Extended overvoltage range" function.

Dimensional drawings

Frame size SL2

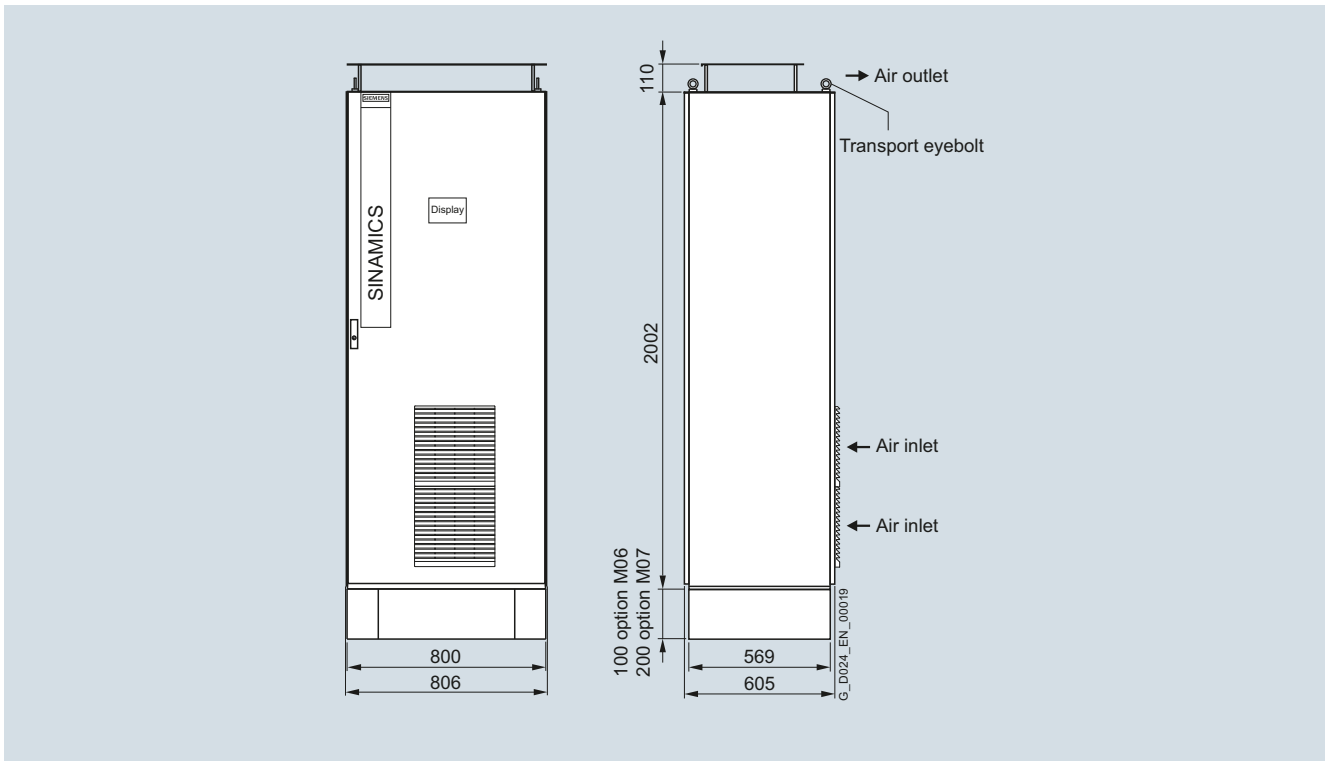

Dimensional drawing applies to standard converters without options. The cabinet dimensions might change if options are selected.

SINAMICS G180 cabinet units, air-cooled	Converter type
6SE0180-1BA33-7AA7	2T3A-87401-200
6SE0180-1BA34-6AA7	2T3A-87401-250
6SE0180-1BA36-3AA7	2T3A-87401-315
6SE0180-1BD33-7AA7	2T3A-87501-250
6SE0180-1BD34-6AA7	2T3A-87501-315
6SE0180-1BD36-3AA7	2T3A-87501-400
6SE0180-1B33-2AA7	2T3A-87601-250
6SE0180-1B33-6AA7	2T3A-87601-315
6SE0180-1B34-2AA7	2T3A-87601-400

SINAMICS G180

SINAMICS G180 cabinet units

SINAMICS G180 cabinet units
air-cooled

Dimensional drawings

Frame size SL21

3

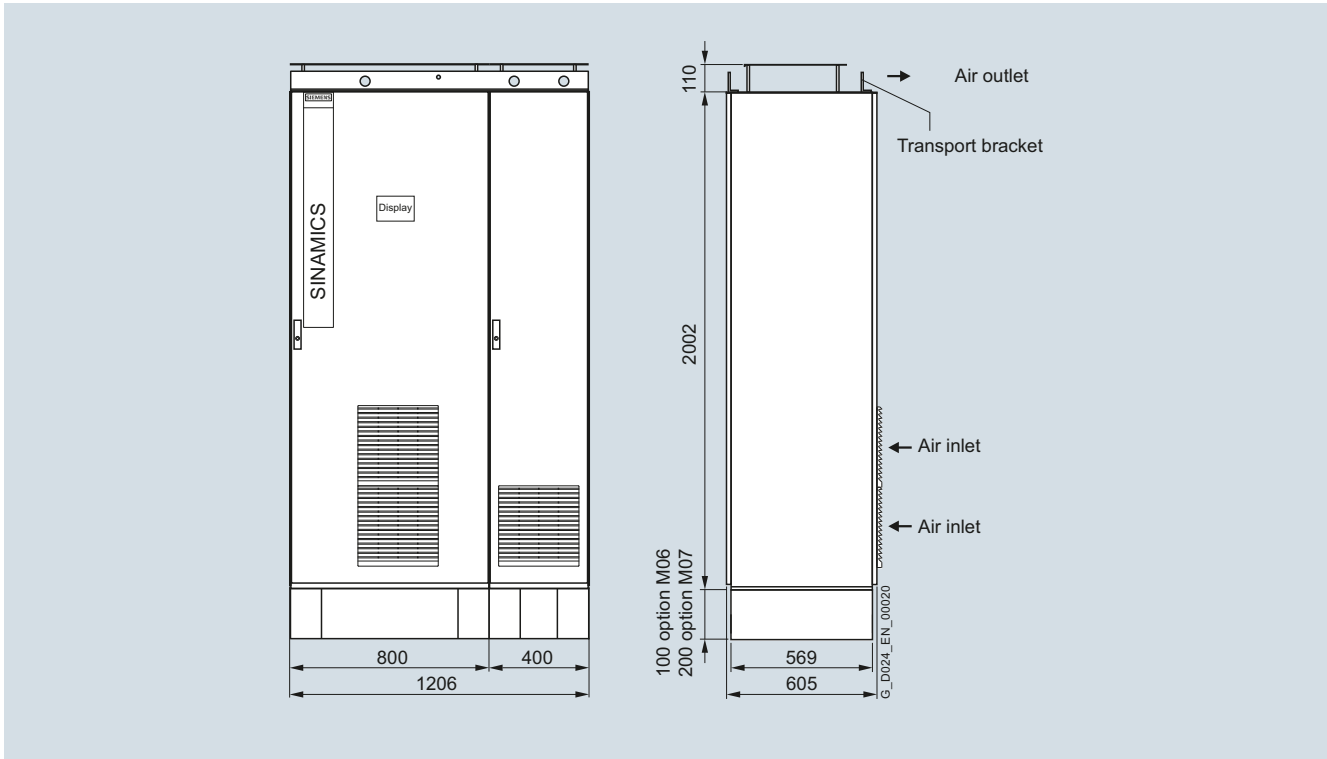

Dimensional drawing applies to standard converters without options. The cabinet dimensions might change if options are selected.

SINAMICS G180 cabinet units, air-cooled	Converter type
6SE0180-1BA37-3AA7	2T3A-87401-400
6SE0180-1BD37-3AA7	2T3A-87501-500
6SE0180-1B35-2AA7	2T3A-87601-500

Dimensional drawings

Frame size SL3

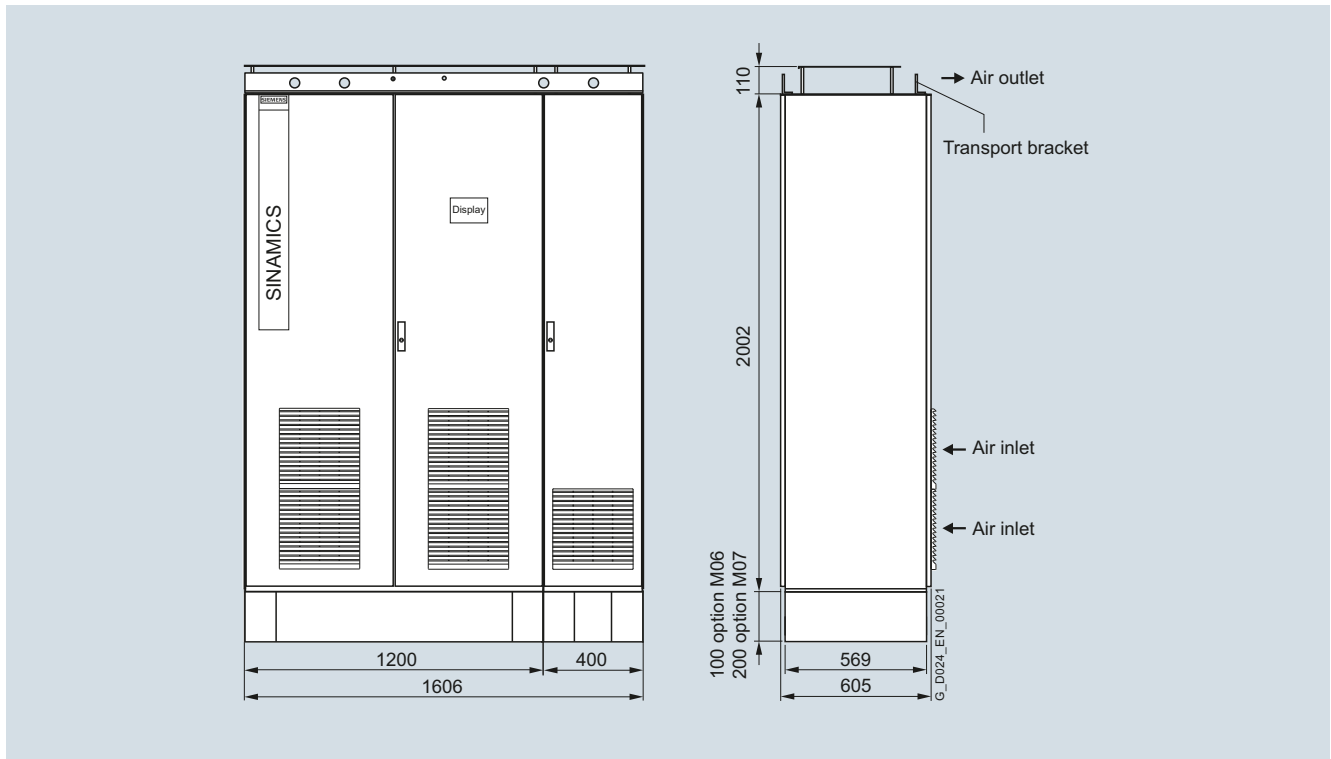

Dimensional drawing applies to standard converters without options. The cabinet dimensions might change if options are selected.

SINAMICS G180 cabinet units, air-cooled	<i>Converter type</i>
6SE0180-1BA38-8AA7	2T3A-87401-500
6SE0180-1BA41-0AA7	2T3A-87401-560
6SE0180-1BA41-1AA7	2T3A-87401-630
6SE0180-1BD38-2AA7	2T3A-87501-560
6SE0180-1BD38-8AA7	2T3A-87501-630
6SE0180-1BD41-0AA7	2T3A-87501-710
6SE0180-1BD41-1AA7	2T3A-87501-800
6SE0180-1B35-7AA7	2T3A-87601-560
6SE0180-1B36-4AA7	2T3A-87601-630
6SE0180-1B37-1AA7	2T3A-87601-710
6SE0180-1B37-7AA7	2T3A-87601-800
6SE0180-1B41-0AA7	2T3A-87601-909
6SE0180-1B41-1AA7	2T3A-87601-910

SINAMICS G180

SINAMICS G180 cabinet units

SINAMICS G180 cabinet units
air-cooled

Dimensional drawings

Frame size SL4

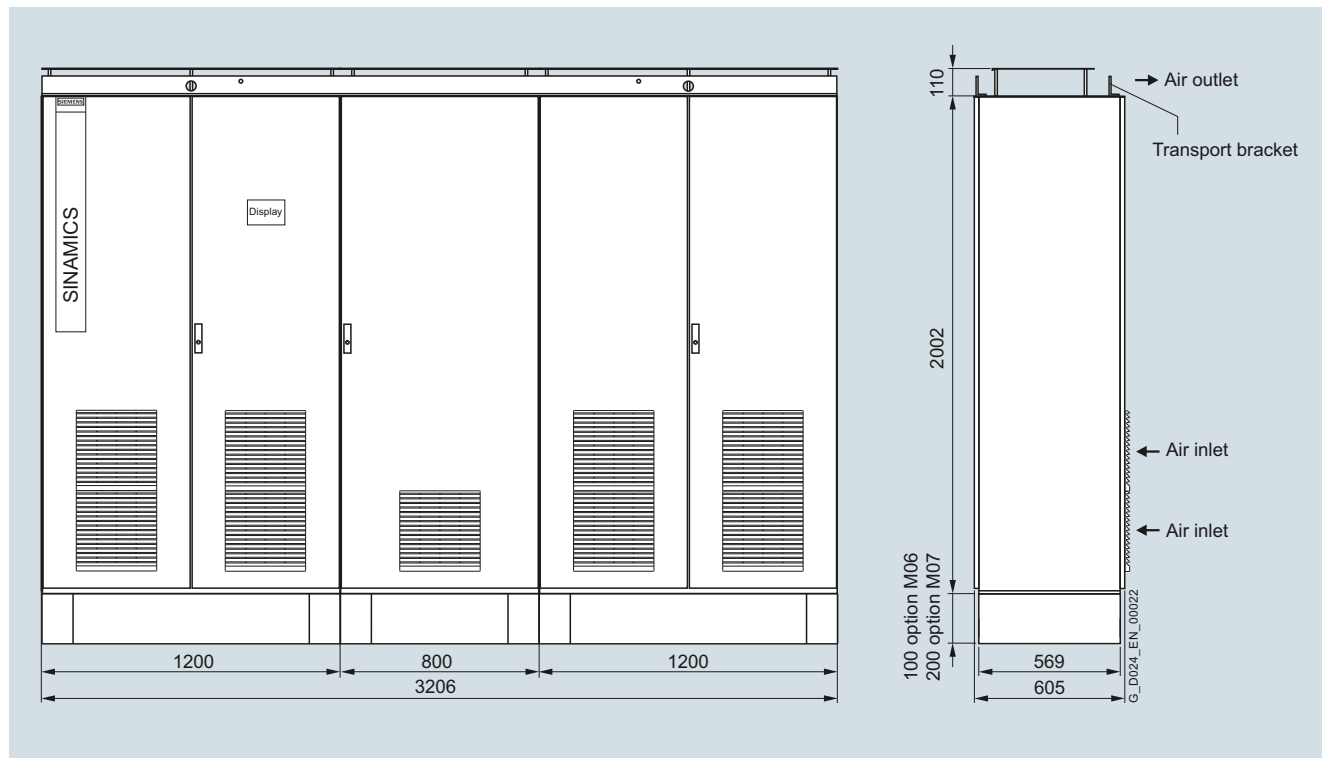

Dimensional drawing applies to standard converters without options. The cabinet dimensions might change if options are selected.

SINAMICS G180 cabinet units, air-cooled	<i>Converter type</i>
6SE0180-1C■41-2AA7	2T3A-87602-912
6SE0180-1C■41-3AA7	2T3A-87602-913
6SE0180-1C■41-5AA7	2T3A-87602-915
6SE0180-1C■41-7AA7	2T3A-87602-917
6SE0180-1C■42-0AA7	2T3A-87602-919
6SE0180-2CH41-2AA7	2T3F-87602-912
6SE0180-2CH41-3AA7	2T3F-87602-913
6SE0180-2CH41-5AA7	2T3F-87602-915
6SE0180-2CH41-7AA7	2T3F-87602-917
6SE0180-2CH42-0AA7	2T3F-87602-919

Dimensional drawings

Frame size SL5

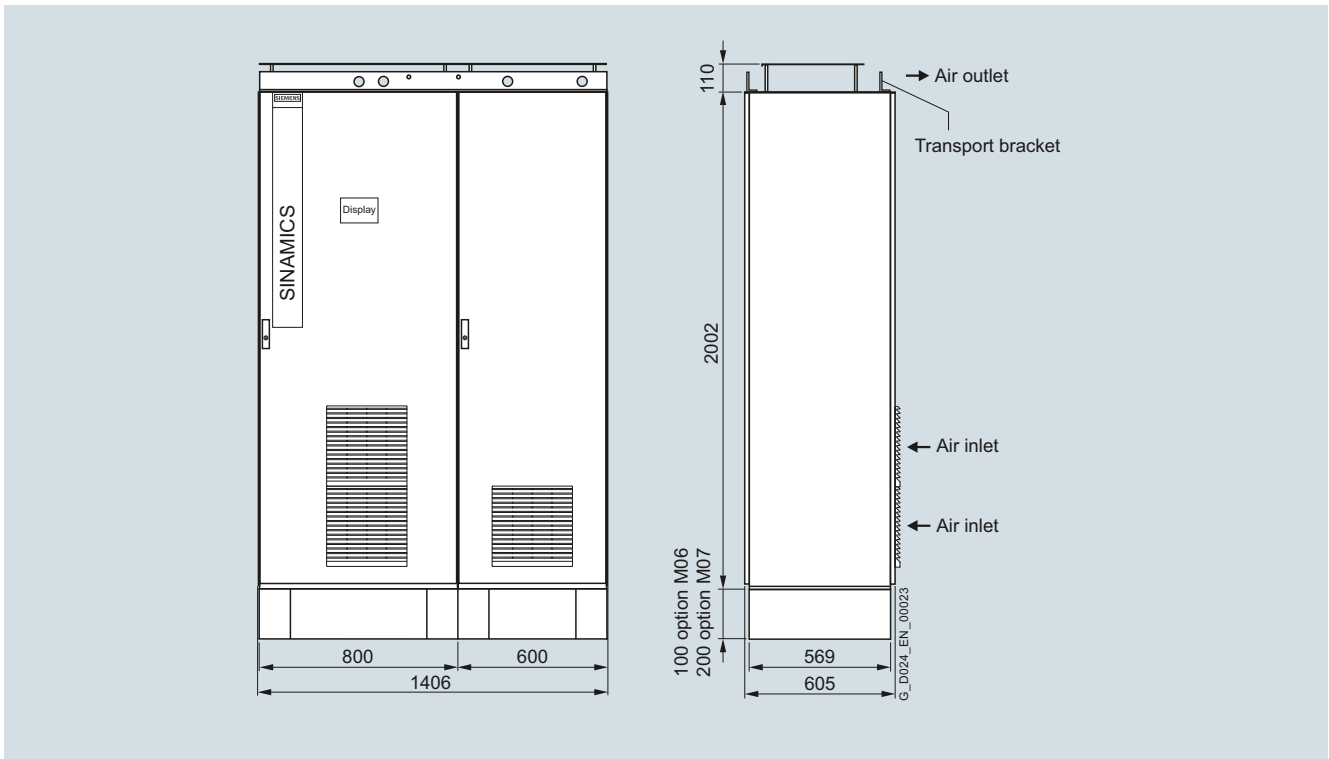

Dimensional drawing applies to standard converters without options. The cabinet dimensions might change if options are selected.

SINAMICS G180 cabinet units, air-cooled	<i>Converter type</i>
6SE0180-2BA33-7AA7	2T3F-87401-200
6SE0180-2BA34-6AA7	2T3F-87401-250
6SE0180-2BA36-3AA7	2T3F-87401-315
6SE0180-2BA37-3AA7	2T3F-87401-400
6SE0180-2BD33-7AA7	2T3F-87501-250
6SE0180-2BD34-6AA7	2T3F-87501-315
6SE0180-2BD36-3AA7	2T3F-87501-400
6SE0180-2BD37-3AA7	2T3F-87501-500
6SE0180-2BH33-2AA7	2T3F-87601-250
6SE0180-2BH33-6AA7	2T3F-87601-315
6SE0180-2BH34-2AA7	2T3F-87601-400
6SE0180-2BH35-2AA7	2T3F-87601-500

SINAMICS G180

SINAMICS G180 cabinet units

SINAMICS G180 cabinet units
air-cooled

Dimensional drawings

Frame size SL6

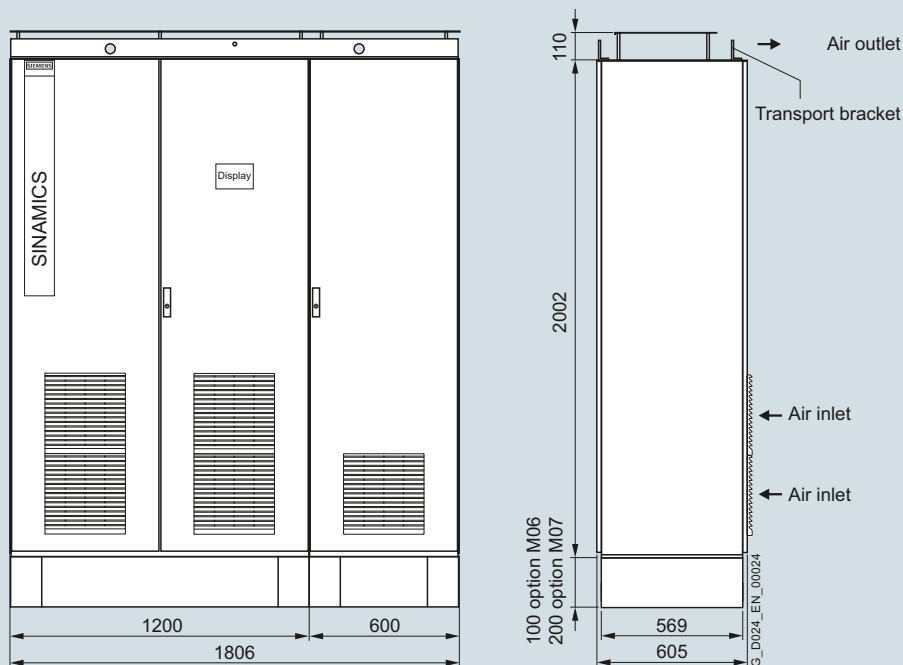

Dimensional drawing applies to standard converters without options. The cabinet dimensions might change if options are selected.

SINAMICS G180 cabinet units, air-cooled	<i>Converter type</i>
6SE0180-2BA38-8AA7	2T3F-87401-500
6SE0180-2BA41-0AA7	2T3F-87401-560
6SE0180-2BA41-1AA7	2T3F-87401-630
6SE0180-2BD38-2AA7	2T3F-87501-560
6SE0180-2BD38-8AA7	2T3F-87501-630
6SE0180-2BD41-0AA7	2T3F-87501-710
6SE0180-2BD41-1AA7	2T3F-87501-800
6SE0180-2BH35-7AA7	2T3F-87601-560
6SE0180-2BH36-4AA7	2T3F-87601-630
6SE0180-2BH37-1AA7	2T3F-87601-710
6SE0180-2BH37-7AA7	2T3F-87601-800
6SE0180-2BH41-0AA7	2T3F-87601-909
6SE0180-2BH41-1AA7	2T3F-87601-910

Dimensional drawings

Frame size SL7

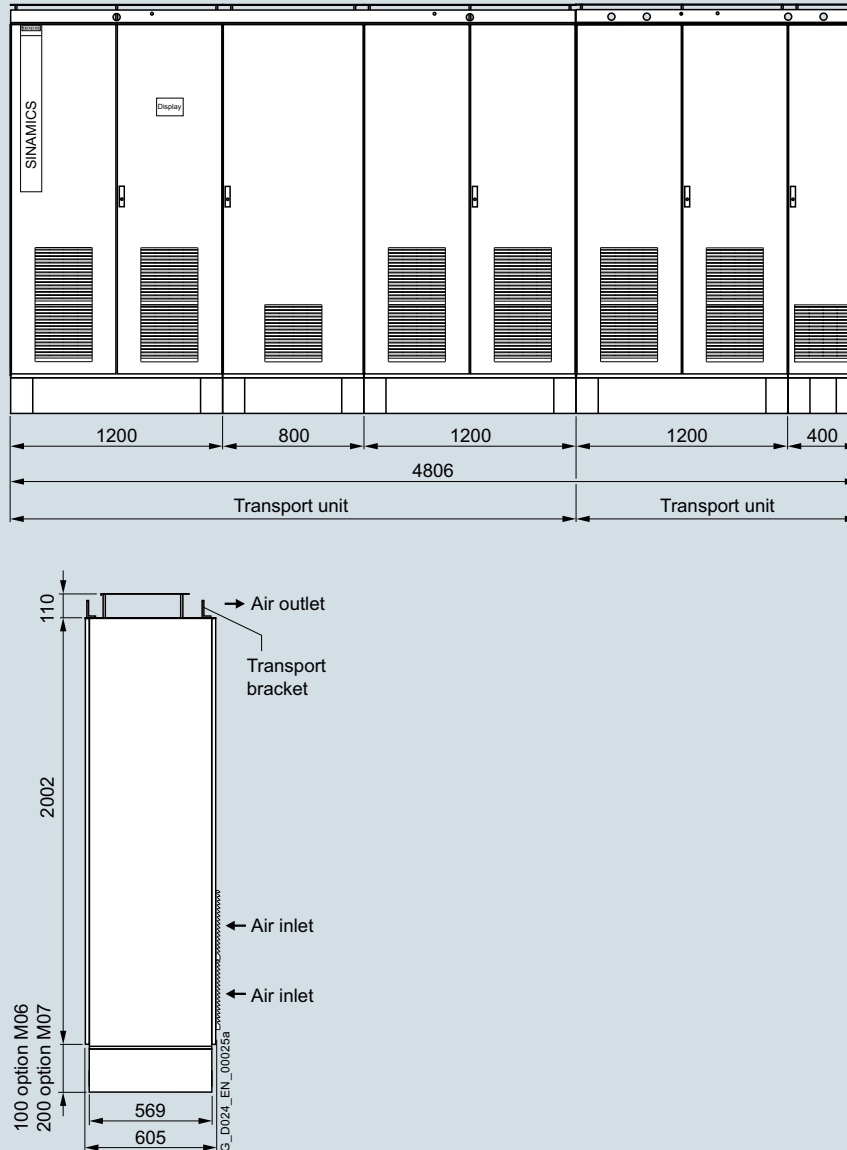

Dimensional drawing applies to standard converters without options. The cabinet dimensions might change if options are selected.

SINAMICS G180 cabinet units, air-cooled	Converter type
6SE0180-2DH42-2AA7	2T3F-87603-920
6SE0180-2DH42-4AA7	2T3F-87603-923
6SE0180-2DH42-7AA7	2T3F-87603-926
6SE0180-2DH43-0AA7	2T3F-87603-929
6SE0180-3DH42-2AA7	2T3K-87603-920
6SE0180-3DH42-4AA7	2T3K-87603-923
6SE0180-3DH42-7AA7	2T3K-87603-926
6SE0180-3DH43-0AA7	2T3K-87603-929

SINAMICS G180

SINAMICS G180 cabinet units

SINAMICS G180 cabinet units air-cooled

Dimensional drawings

Frame size SL8

3

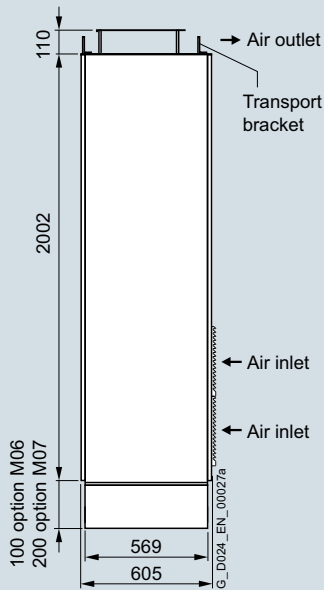
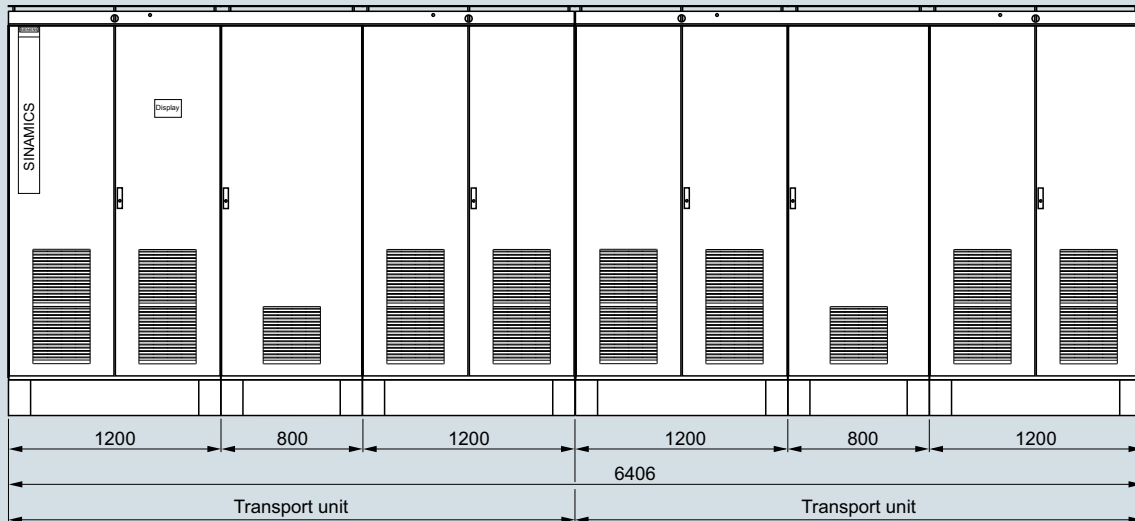

Dimensional drawing applies to standard converters without options. The cabinet dimensions might change if options are selected.

SINAMICS G180 cabinet units, air-cooled	Converter type
6SE0180-2EH43-2AA7	2T3F-87604-931
6SE0180-2EH43-6AA7	2T3F-87604-935
6SE0180-2EH44-0AA7	2T3F-87604-939

Dimensional drawings

Frame size SL9

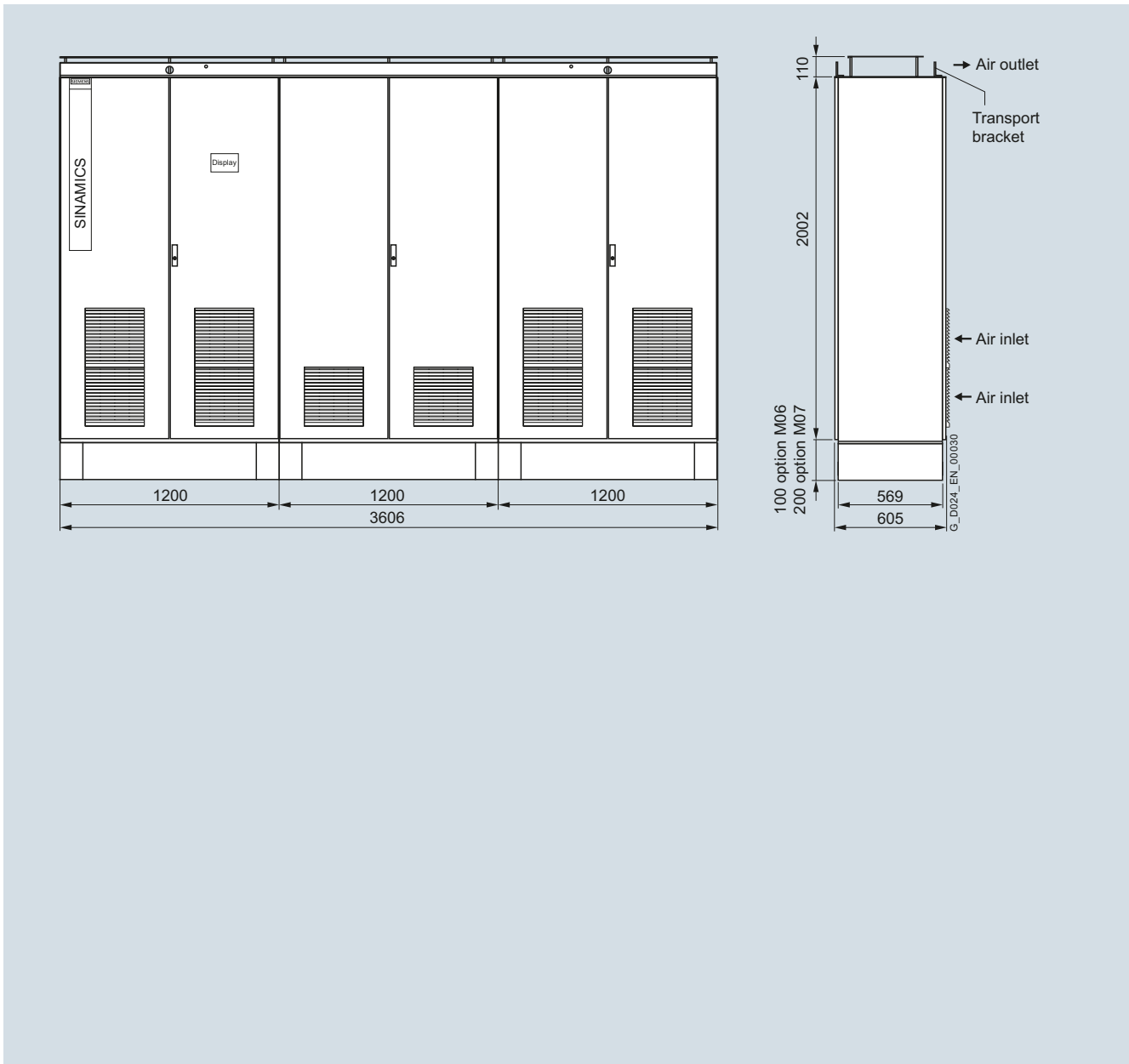

3

Dimensional drawing applies to standard converters without options. The cabinet dimensions might change if options are selected.

SINAMICS G180 cabinet units, air-cooled	<i>Converter type</i>
6SE0180-4CH41-2AA7	2T3L-87602-912
6SE0180-4CH41-3AA7	2T3L-87602-913
6SE0180-4CH41-5AA7	2T3L-87602-915
6SE0180-4CH41-7AA7	2T3L-87602-917
6SE0180-4CH42-0AA7	2T3L-87602-919

SINAMICS G180

SINAMICS G180 cabinet units

SINAMICS G180 cabinet units air-cooled

Dimensional drawings

Frame size SL10

3

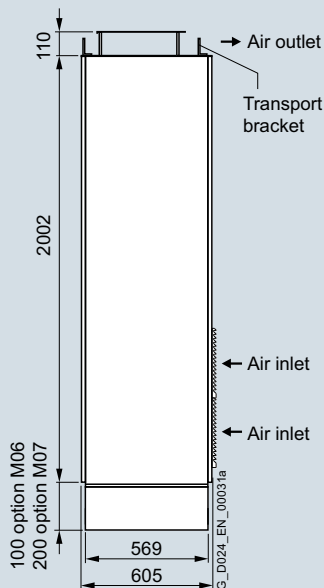
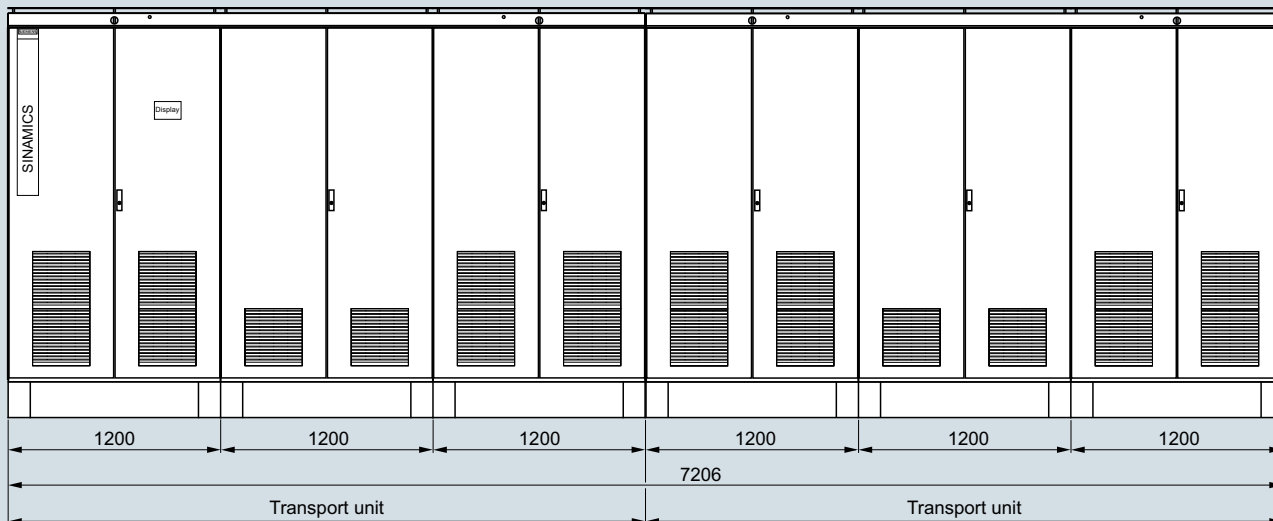

Dimensional drawing applies to standard converters without options. The cabinet dimensions might change if options are selected.

SINAMICS G180 cabinet units, air-cooled	Converter type
6SE0180-4EH43-2AA7	2T3L-87604-931
6SE0180-4EH43-6AA7	2T3L-87604-935
6SE0180-4EH44-0AA7	2T3L-87604-939

Dimensional drawings

Frame size SL11

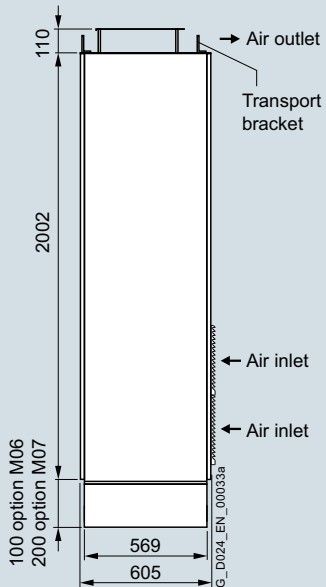
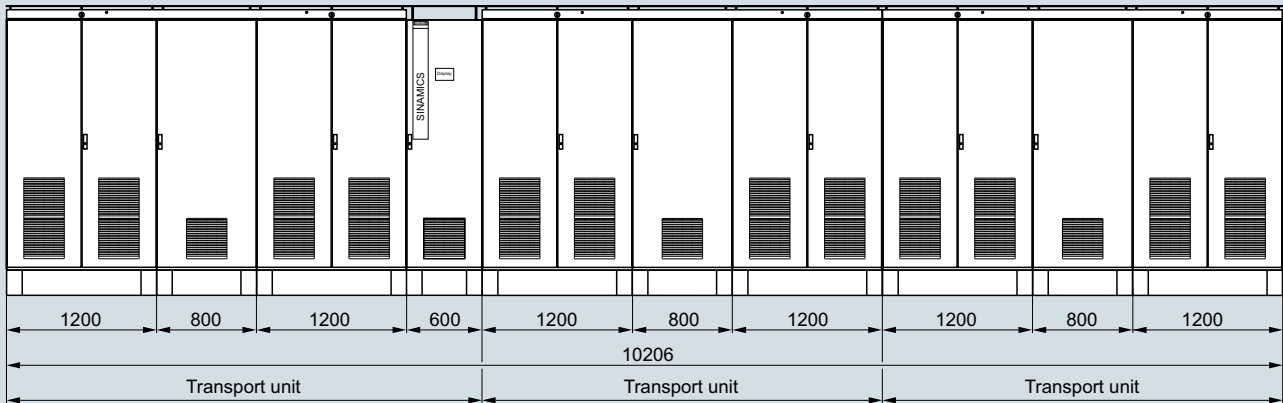

Dimensional drawing applies to standard converters without options. The cabinet dimensions might change if options are selected.

SINAMICS G180 cabinet units, air-cooled	Converter type
6SE0180-3HH44-3AA7	2T3K-87606-941
6SE0180-3HH44-8AA7	2T3K-87606-947
6SE0180-3HH45-4AA7	2T3K-87606-953
6SE0180-3HH46-0AA7	2T3K-87606-958

SINAMICS G180

SINAMICS G180 cabinet units

SINAMICS G180 cabinet units air-cooled

Dimensional drawings

Frame size SL12

3

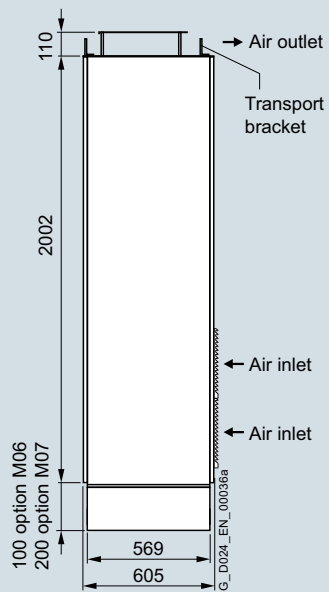
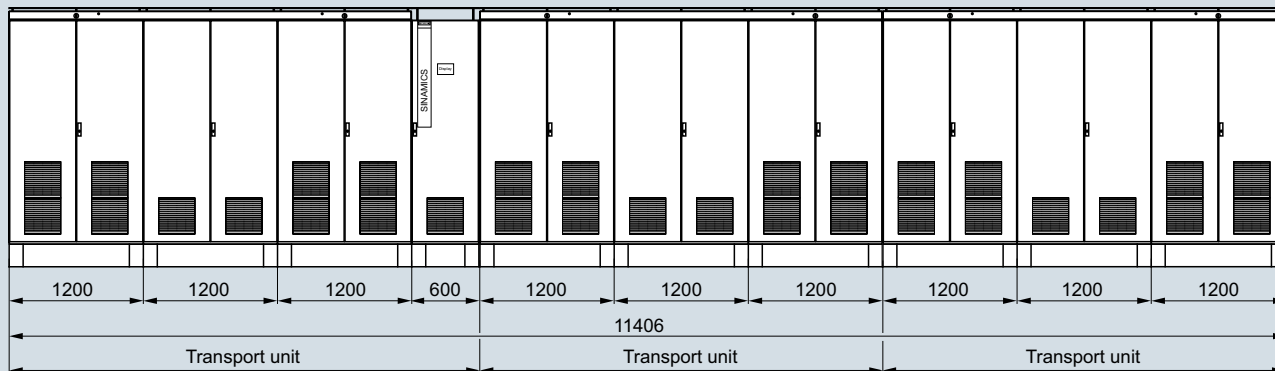

Dimensional drawing applies to standard converters without options. The cabinet dimensions might change if options are selected.

SINAMICS G180 cabinet units, air-cooled	Converter type
6SE0180-4HH44-3AA7	2T3L-87606-941
6SE0180-4HH44-8AA7	2T3L-87606-947
6SE0180-4HH45-4AA7	2T3L-87606-953
6SE0180-4HH46-0AA7	2T3L-87606-958

Option descriptions



4/2	Standard options	4/28	M20 and N50 Wiring options
4/2	B48 Test sequence schedule	4/28	Q80, Q81, Q82, Q83, Q84 and Q85 Extension of the liability for defects
4/2	B43 and B45 Production flowchart	4/29	S01, S02, S08, S09, S11, S12, S21, S22, S23, S24, S31, S41 and G08 Standard accessories packages
4/2	C36, C38, C43, C48 and Y36 External auxiliary power supply	4/30	T01 and Y33 Label for plant identification
4/2	C55, C56, C57 and Y55 External control voltage supply	4/30	T23, T24, T25, T26, T58, T60, T74, T76, T82, T85, T86 and Y14 Converter display language (language 1/language 2)
4/3	D01 and D02 Converter documentation	4/30	U04 EAC certificate
4/3	G13, G14, G15, G16 and G18 Accessories for IMS (Inverter Management Software)	4/31	H80, H81, H82, H83, H84, H85 and H86 Cabinet widths for cabinet systems with compact units
4/4	M96 and M94 Marking of cable cores and items of equipment	4/31	H90, H91, H92, H93 and H94 Additional cabinets for cabinet units
4/5	E85 Board for mains supply backup	4/31	V61, V62 and V63 Ambient temperature for air-cooled converters
4/5	G01, G06, G20, G22 and G27 Additional boards for bus connection	4/31	V86, V87, V88 and V89 Installation altitude
4/7	G02, G03, G04 and G05 Peripheral boards 1 to 4	4/31	V70, V71, V72, V73, V74, V75, V76, V77, V78, V79, V80 and Y70 Line voltages
4/13	G10, G11, G12, K14, K15 and K37 Control elements and display instruments in control cabinet door	4/31	Y13 Language of manual
4/15	L00 and L02 RFI suppression filter		
4/15	L03 and L04 Line Harmonics Filter for cabinet units		
4/15	L05, L06 and L07 Line Harmonics Filter for compact units and cabinet systems		
4/16	L10, L14, L15, L16 and L17 Output filter		
4/17	L48, L49, L50, L55, N35, N36, Y11 and Y98 Accessories		
4/19	L72 Braking chopper		
4/19	N39 DC link connected to terminals		
4/19	L80, L81, L82, L83 and Y80 ATEX certified PTC monitoring relay		
4/20	L87 Insulation monitoring		
4/21	L90, L91, L92, L93, L94, Y90 and Y94 Pt100 evaluation unit		
4/23	M05, M06, M07, M13, M17, M19, M24, M28, M34, M38, M39, M40, M59, M78, Y09 and Y19 Cabinet options		
4/26	M21, M41, M43, M54 and M63 Degrees of protection		
		4/32	Inspection option
		4/32	F71 Inspection for converters
		4/33	Engineer To Order – ETO
		4/33	Engineering

SINAMICS G180

Option descriptions

Standard options

Options

B48

Test sequence schedule

Option **B48** provides an order-specific test sequence schedule. This will be sent by e-mail approximately 6 weeks following receipt of order in PDF format (English/German).

B43 and B45

Production flowchart

Inadmissible option combinations **B43** and **B45**

Documentation, production flowcharts	B43	B45
Generated once	B43	—
Updated every month	B45	—

— Options mutually exclude each other.

Options **B43** and **B45** provide production flowcharts. These will be sent by e-mail following receipt of order either in MPP format (Microsoft Project) or in PDF format (English/German) as required. Please select format.

Option	Description
B43	Production flowchart: Generated once
B45	Production flowchart: Updated every month

C36, C38, C43, C48 and Y36

External auxiliary power supply

With options **C36, C38, C43, C48** and **Y36**, a connection terminal is available to the customer that can be used to supply loads (cabinet fan, cabinet heater, cabinet lighting, PLC, etc.) from an external power source. The supply system type for options C36, C38, C43, and C48 is grounded (TN/TT system). Only one phase is protected using a suitable miniature circuit breaker. Different voltages and supply system types are defined using option Y36. Please specify additional protection or connection of the N conductor (prescribed in certain countries).

Auxiliary DC voltage on request.

Option	Description
C36	Connection of 230 V 1 AC 50 Hz auxiliary voltage provided by the customer The maximum current consumption (depending on the power) is 10 A
C38	Connection of 400 V 3 AC 50 Hz auxiliary voltage provided by the customer The maximum current consumption (depending on the power) is 10 A
C43	Connection of 500 V 3 AC 50 Hz auxiliary voltage provided by the customer The maximum current consumption (depending on the power) is 10 A
C48	Connection of 690 V 3 AC 50 Hz auxiliary voltage provided by the customer The maximum current consumption (depending on the power) is 10 A
Y36	Connection of different level of 3-phase AC voltage provided by the customer; please specify voltage The maximum current consumption (depending on the power) is 10 A

C55, C56, C57 and Y55

External control voltage supply

Inadmissible option combinations **C55, C56, C57** and **Y55**

External control voltage supply	C55	C56	C57	Y55
Connection of 24 V DC control voltage provided by the customer	C55	—	—	—
Connection of 230 V 1 AC 50 Hz control voltage provided by the customer, <u>no</u> UPS backup	C56	—	—	—
Connection of 230 V 1 AC 50 Hz control voltage provided by the customer; UPS backup	C57	—	—	—
Connection of different level of single-phase AC voltage provided by the customer; please specify voltage	Y55	—	—	—

— Options mutually exclude each other.

With options **C55, C56, C57** and **Y55**, an external current source is defined for the converter. This is necessary in the following situations:

- If the display should indicate correctly even though no line voltage is present and the converter should not indicate a fault.
- The initialization time for the converter of approximately 3 s for temporary power failures does not apply in the case of an external, backed-up control voltage (precharging and synchronization time, however, remain unaffected).

If no external control voltage supply is selected, the converter will be supplied from the DC link in the case of compact units without a main contactor. For the following compact units, an additional board is required for mains supply backup (option E85):

Type	Converter type
6SE0100-1A■23-4AA7	2T2A-07600-030
6SE0100-1A■24-2AA7	2T2A-07600-037
6SE0100-1A■25-0AA7	2T2A-07600-045
6SE0100-1A■25-8AA7	2T2A-07600-055
6SE0100-1A■28-0AA7	2T2A-07600-075
6SE0100-1A■31-0AA7	2T2A-07600-090
6SE0100-1A■31-2AA7	2T2A-07600-110
6SE0100-1A■31-4AA7	2T2A-07600-132
6SE0100-1A■31-7AA7	2T2A-07600-160
6SE0100-1A■32-1AA7	2T2A-07600-200

For cabinet units with and without input contactors and for cabinet systems with input contactors, the control voltage is generated from the converter line voltage by a control transformer.

Options

Advantage:

When the converter control voltage is supplied from the DC link, this provides a backup function for drives with a coupled rotating mass (e.g. fan drive). This means that the DC link of the converter is maintained for a short time in the case of a temporary voltage drop or power failure due to continued rotation of the rotating mass on the motor. The control voltage for the converter is backed-up until the DC link voltage fails due to standstill of the rotating mass, or until the parameter "t-restart" causes switch-off.

Option	Description
C55	Connection for 24 V DC external control voltage provided by the customer With the option C55 , the customer provides the control voltage (24 V DC $\pm 15\%$) for the converter. The maximum current consumption is 4 A. This option is only available for compact units and cabinet systems.
C56	Connection for 230 V 1 AC 50 Hz external control voltage provided by the customer, no UPS backup With option C56 the customer provides the control voltage (230 V 1 AC $+15\%$ -20% ; 47 to 63 Hz) for the converter. The control voltage has <u>no</u> UPS backup. The maximum current consumption is 4 A.
C57	Connection for 230 V 1 AC 50 Hz external control voltage provided by the customer, with UPS backup With option C57 the customer provides the control voltage (230 V 1 AC $+15\%$ -20% ; 47 to 63 Hz) for the converter. The control voltage <u>has</u> UPS backup. The maximum current consumption is 4 A.
Y55	Connection for different level of single-phase AC control voltage with 47 to 63 Hz provided by the customer, please specify voltage With option Y55 the customer provides the control voltage for the converter. The maximum current consumption is 4 A.

D01 and D02 Converter documentation

For the scope of the converter documentation, see the "Documentation" section under "Services and documentation".

Option	Description
D01	Manual and set of diagrams in PDF format per e-mail, German/English
D02	Manual in PDF format, set of diagrams in DXF format per e-mail, German/English

Note:

Please ask your Siemens sales partner if the documentation or set of diagrams are required in a different language.

G13, G14, G15, G16 and G18 Accessories for IMS (Inverter Management Software)

G13 USB PROFIBUS interface (supplied separately packed)



G13 Softing Automation GmbH, PBpro USB

Active single-channel USB high-speed interface for connecting a PC with IMS to a PROFIBUS network. The interface is suitable for control and visualization tasks as well as for parameterization and analysis applications via the IMS. All SINAMICS G180 converters in the PROFIBUS network can be addressed.

No additional power connection is required for this converter. The cable on the converter has a double PROFIBUS sub-D 9-pin connection (socket/connector) for connecting to PROFIBUS. As a result, a simple connection is possible directly on the SINAMICS G180 with PROFIBUS board (**G01**).

Note:

The installation notes in the help function of IMS must be observed.

G14 Ethernet-PROFIBUS gateway



G14 Softing Automation GmbH, PBpro ETH, single-channel Ethernet-PROFIBUS gateway

Gateway between host systems on Ethernet and the PROFIBUS bus system. Suitable for network configuration, device parameterization or acquisition of operating data. All SINAMICS G180 converters in the PROFIBUS system can be monitored and parameterized.

The Ethernet-PROFIBUS gateway can be installed in the converter cabinet or supplied separately packed. Please specify your requirements in the order. The gateway is normally installed at the most favorable transition point between Ethernet and PROFIBUS.

Technical data:

- Dimensions (W x H x D) 47 x 131 x 111 mm
- Mounting on 35 mm DIN rail
- Power supply 24 V DC ($\pm 20\%$); 0.3 A
- Operating temperature 0 °C to 55 °C

Scope of supply:

- Ethernet interface on PROFIBUS
- Installation manual
- CD with Windows drivers

Note:

The installation notes in the help function of IMS must be observed.

If the Ethernet-PROFIBUS gateway is supplied separately with the converter, a separately power supply unit is required. This is not part of the scope of supply.

SINAMICS G180

Option descriptions

Standard options

Options

G15 Ethernet to RS232/485/422 converter (supplied separately packed)



G15 Phoenix Contact, FL COMSERVER BASIC 232/422/485

With option **G15** a serial/Ethernet converter is supplied separately packed. If several converters are interconnected over an RS485 network, up to 128 converters can be connected to Ethernet using one converter.

Technical data:

- Dimensions (W × H × D) 22.5 × 99 × 116 mm
- Power supply 19.2 to 28.8 V AC/DC; typ. 100 mA at 24 V

Note:

The installation notes in the help function of IMS must be observed.

An external power supply unit is required for the Ethernet to RS232/485/422 converter which is not part of the scope of supply.

G16 USB cable A/B, 2 m (supplied separately packed)



G16 USB cable A/B (example shown)

Option **G16** comprises a 2 m long USB cable for parameterizing the SINAMICS G180 from the IMS.

G18 USB connector on front of control cabinet door



G18 USB connector on front of control cabinet door (example shown)

With option **G18** a USB connector is installed in the control cabinet door that allows the converter to be parameterized from the IMS without having to open the cabinet door. IP65 degree of protection.

M96 and M94

Marking of cable cores and items of equipment

M96 Dual marking of items of equipment



M96 Example of dual marking of items of equipment

With option **M96** the items of equipment are marked twice, once on the equipment and once directly adjacent to the mounting location of the equipment.

M94 Cable marking

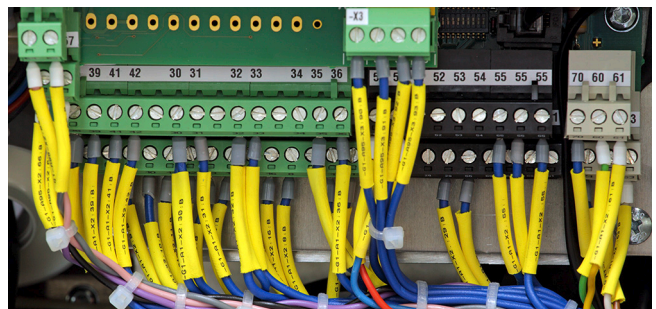

M94 Example of cable marking

- Cable markings using marking collars.
- The terminal designation and the item designation are labeled on the cable.

Example:

Terminal -X2:41 → Cable is marked with -X2:41.

Options

E85

Board for mains supply backup

To enable the control voltage to be generated from the DC link for the following converter types, option **E85** (series-connected power supply unit for mains supply backup) is required.

This option must be ordered separately for all cabinet units and for the following compact units:

Type	Converter type
6SE0100-1A23-4AA7	2T2A-07600-030
6SE0100-1A24-2AA7	2T2A-07600-037
6SE0100-1A25-0AA7	2T2A-07600-045
6SE0100-1A25-8AA7	2T2A-07600-055
6SE0100-1A28-0AA7	2T2A-07600-075
6SE0100-1A31-0AA7	2T2A-07600-090
6SE0100-1A31-2AA7	2T2A-07600-110
6SE0100-1A31-4AA7	2T2A-07600-132
6SE0100-1A31-7AA7	2T2A-07600-160
6SE0100-1A32-1AA7	2T2A-07600-200

Advantage:

When the converter control voltage is supplied from the DC link, this provides a backup function for drives with a coupled rotating mass (e.g. fan drive). This means that the DC link of the converter is maintained for a short time in the case of a temporary voltage drop or power failure due to continued rotation of the rotating mass on the motor. The control voltage for the converter is therefore backed up for a short time.

G01, G06, G20, G22 and G27

Additional boards for bus connection

Inadmissible option combinations G01, G20, G22, G27

Additional boards for bus connection		G01	G06	G20	G22	G27
Board for PROFIBUS DPV1	G01		–	–	–	–
Board for PROFINET CU	G06	–		–	–	–
Board for CANopen	G20	–	–		–	–
Board for Modbus RTU	G22	–	–	–		–
Board for Modbus TCP	G27	–	–	–	–	

– Options mutually exclude each other.

G01 Board for PROFIBUS DPV1



G01 PROFIBUS board for SINAMICS G180 in compact unit

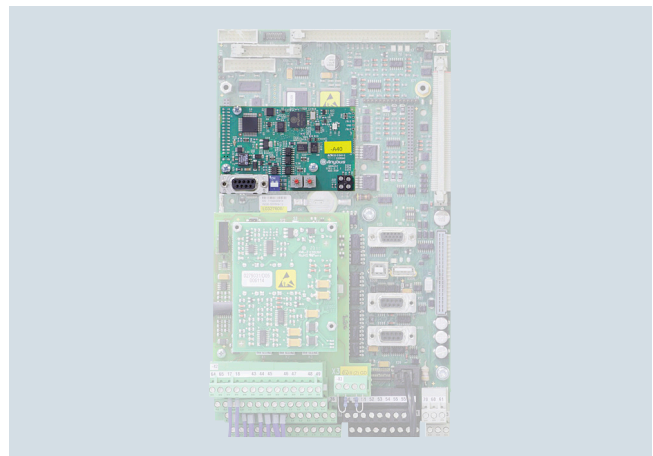

G01 PROFIBUS board for SINAMICS G180 in cabinet unit

Option **G01** for the PROFIBUS DPV1 board is suitable for cyclic and non-cyclic data transfer and can be retrofitted in compact units and cabinet units at any time.

SINAMICS G180

Option descriptions

Standard options

Options

G06 Board for PROFINET CU

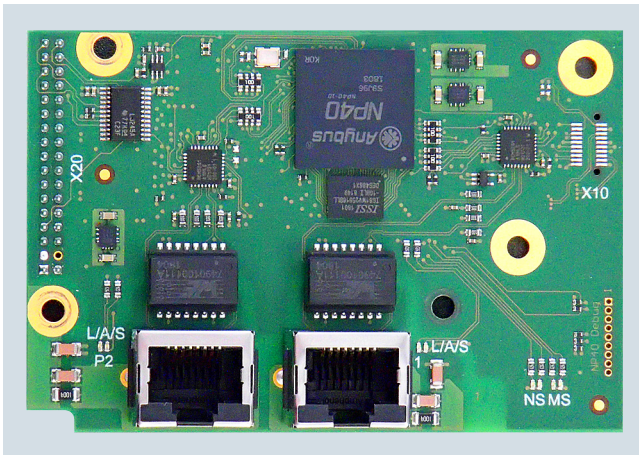

G06 PROFINET CU

The option **G06** PROFINET CU board allows to communicate with the SINAMICS G180 via a PROFINET IO network.

Data transmission takes place electrically via a copper cable with an RJ45 connector. If no other bus system is installed yet, this board can be retrofitted in compact and cabinet units.

G20 Board for CANopen

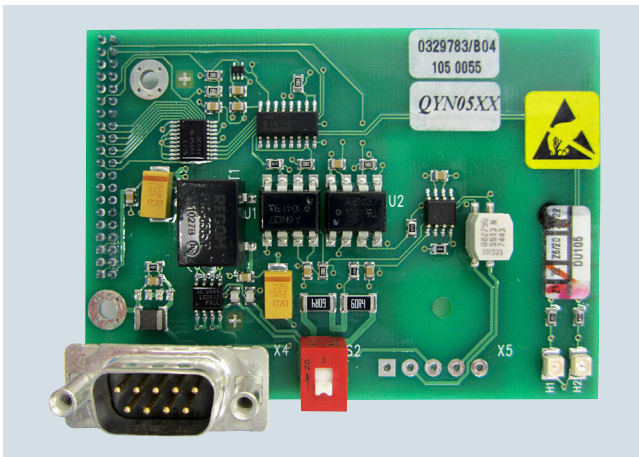

G20 CANopen

Option **G20** (board for CANopen) transfers data in binary form. Fieldbus connection is implemented in accordance with the CANopen standard. This board can be retrofitted in compact units and cabinet units at any time, provided that no other bus system has been installed beforehand.

G22 Board for Modbus RTU

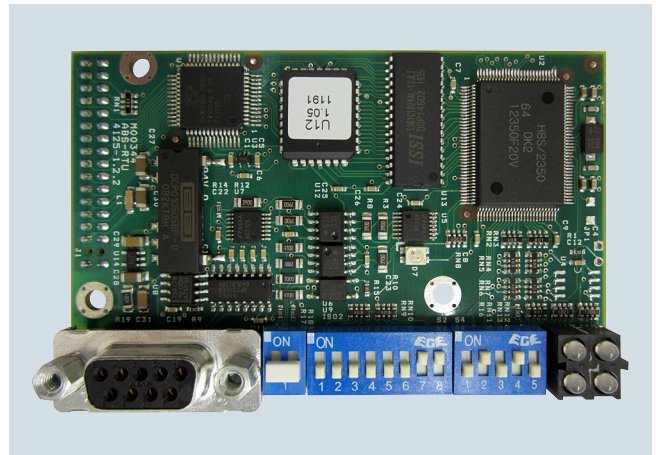

G22 Modbus RTU

Option **G22** (board for Modbus RTU) transfers data in binary form. This board can be retrofitted in compact units and cabinet units at any time, provided that no other bus system has been installed beforehand.

G27 Board for Modbus TCP

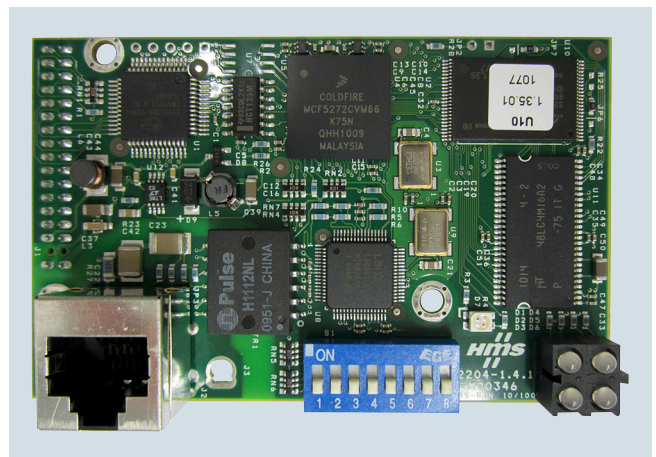

G27 Modbus TCP

Option **G27** (board for Modbus TCP) is very similar to Option **G22** (board for Modbus RTU), except that TCP packages are used to send the data. This board can be retrofitted in compact units and cabinet units at any time, provided that no other bus system has been installed beforehand.

Standard options

Options

G02, G03, G04 and G05 Peripheral boards 1 to 4

Inadmissible option combinations
G02, G03, G04 and G05

Peripheral board 1 ... 4		G02	G03	G04	G05
Peripheral board 1	G02		—	—	—
Peripheral board 2	G03	—		—	—
Peripheral board 3	G04	—	—		—
Peripheral board 4	G05	—	—	—	

— Options mutually exclude each other.

The functionality of the converter is expanded with the peripheral board. Every converter can be fitted or even retrofitted with one of these peripheral boards.

Boards with safety-related inputs (PTC thermistor or the function "Safe Torque Off") are only permitted to be retrofitted by our authorized qualified personnel.

In addition to the main board, peripheral boards 2 and 4 are also expanded by a daughterboard which contains the circuitry for the PTC thermistor inputs.

	Peripheral board			
	1	2	3	4
2 PTC thermistor inputs for ATEX-certified motor temperature monitoring for motors in hazardous zones (prewarning/trip)				
One input "Safe Torque Off" acc. to EN ISO 13849-1, Cat. 3. PL d or SIL 2 acc. to EN 61508				
9 digital inputs (DI)				
3 relay outputs (DO)				
2 analog outputs (AO)				
24 V / 300 mA power supply unit				

G02 Peripheral board 1

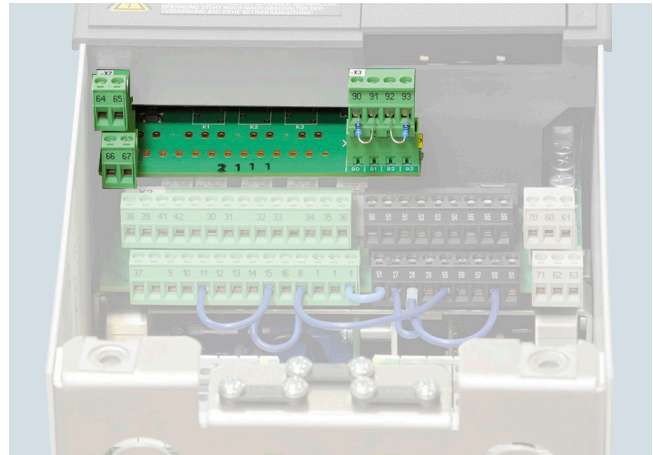

G02 Peripheral board 1

Option **G02** (peripheral board 1) provides in addition to standard converter terminals:

- 2 analog outputs (AO)
4 to 20 mA/0 to 10 V

Standard assignment of inputs/outputs

The table below provides an overview of the pre-assignment function of interfaces in the pin assignments for the "Standard" application.

Signal designation	Function
Internal PTC thermistor input 90, 91, 92, 93	Not assigned
Internal analog output 64, 65	Torque
Internal analog output 66, 67	Power

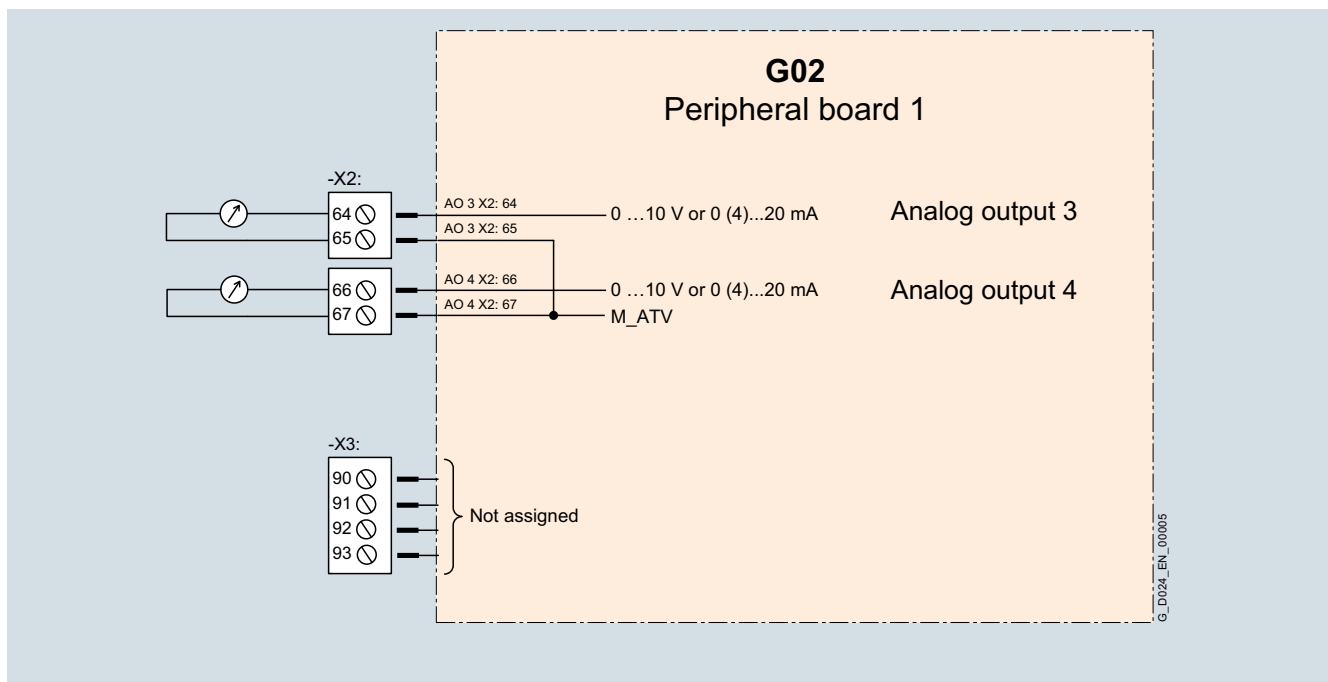

G02 Circuit diagram for peripheral board 1

SINAMICS G180

Option descriptions

Standard options

Options

G03 Peripheral board 2

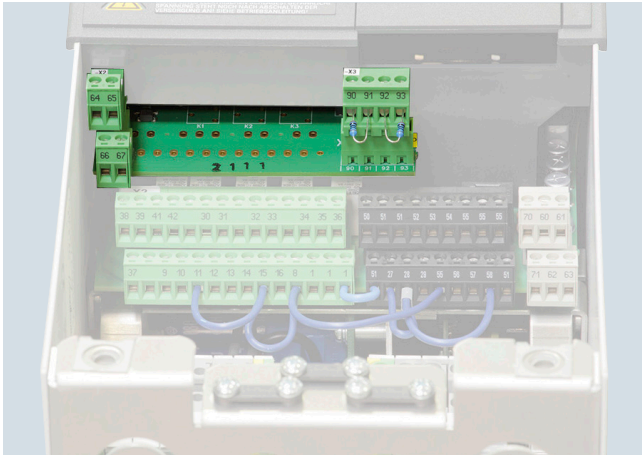

G03 Peripheral board 2 in the compact unit

Option **G03** (peripheral board 2) provides in addition to standard converter terminals:

- 2 analog outputs (AO) 4 to 20 mA/0 to 10 V
- 2 PTC thermistor inputs for ATEX-certified motor temperature monitoring for motors in hazardous zones (prewarning/trip)
- PTC thermistor monitoring without contactor through monitoring unit integrated in converter, certified to SIL 1 in accordance with EN 61508

The converter controller processes the signal of the peripheral board. In the event of excessive motor temperature, or the function "Safe Torque Off", the converter inhibits the firing signals of the IGBTs. The voltage supply of the driver stages is also switched off. These two redundant, diverse and self-monitored switch-off paths ensure that the power infeed to the motor is safely interrupted. Further heating or rotation of the motor is excluded. The converter can only be reset or switched on when the motor has cooled down sufficiently and the fault has been acknowledged. When the voltage fails, the converter safely interrupts the power infeed to the motor, because firing signals are no longer transferred. If a fault was active at the moment of power failure, the converter will also be in fault status when power is restored.

Standard assignment of inputs/outputs

The table below provides an overview of the pre-assignment function of interfaces in the pin assignments for the "Standard" application.

Signal designation	Function
Internal PTC thermistor input 90, 91	PTC thermistor for disconnection (ATEX-certified)
Internal PTC thermistor input 92, 93	PTC thermistor for warning
Internal analog output 64, 65	Torque
Internal analog output 66, 67	Power

4

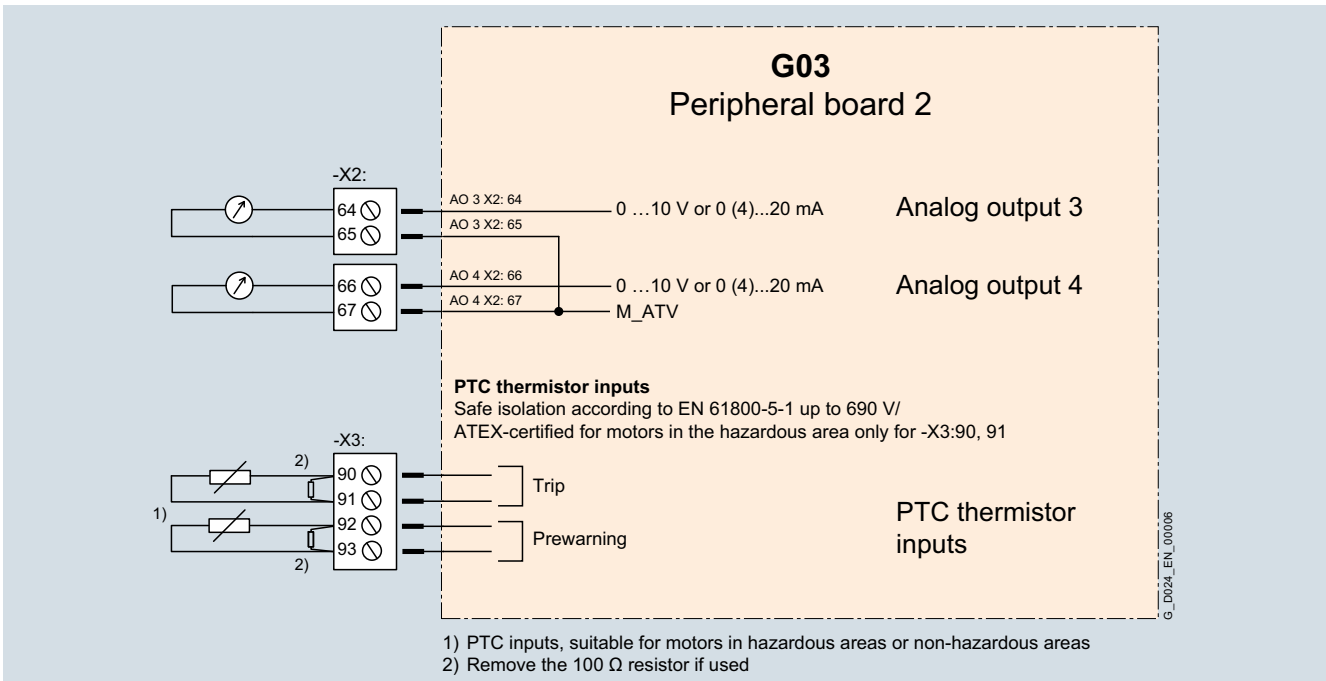

G03 Circuit diagram for peripheral board 2

Options

G04 Peripheral board 3

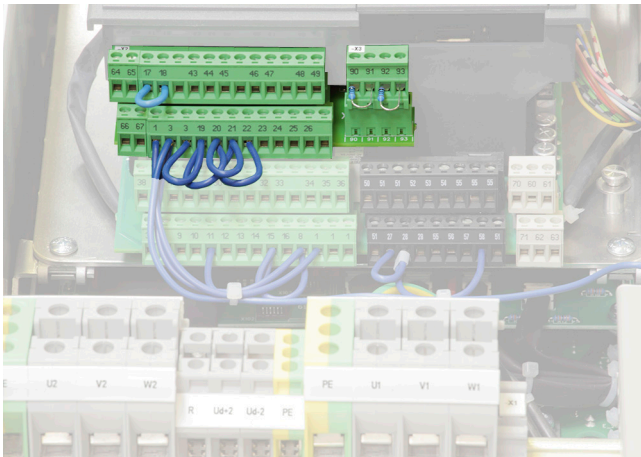

G04 Peripheral board 3 in the compact unit

Option **G04** (peripheral board 3) provides in addition to standard converter terminals:

- 2 analog outputs (AO) 4 to 20 mA/0 to 10 V
- One digital input "Safe Torque Off" (STO, single-channel or two-channel) acc. to EN ISO 13849-1, Cat. 3 or SIL 2 acc. to EN 61508
9 digital inputs (DI)
- 3 relay outputs (DO)
In addition, the relay outputs here are not only isolated from the converter electronics but also from each other.
- 24 V / 300 mA power supply unit

SIL 2 (acc. to EN 61508) – STO (Safe Torque Off).

Safe Torque Off (STO) function implemented according to SIL 2 to EN 61508.

The "Safe Torque Off" (STO) function has a redundant switch-off path in the converter. The implementation is performed using hardware. A relay in the power unit of the converter disconnects the power supply of the IGBT driver. A second circuit, also via hardware, produces a controller disable.

The "Safe Torque Off" input can be implemented with either one or two channels. The board is coded for single-channel activation at the factory. If two-channel activation is required, please specify this in the order. Digital input X2:24 is reserved for the two-channel version.

Standard assignment of inputs/outputs

The table below provides an overview of the pre-assignment function of interfaces in the pin assignments for the "Standard" application.

Signal designation	Function
Internal digital input 19, 20	24 V DC; "Safe Torque Off" acc. to EN ISO 13849-1, Cat. 3; or SIL 2 acc. to EN 61508
Internal digital input 6, 7, 21, 22, 23, 24, 25, 26	Freely parameterizable
Internal PTC thermistor input 90, 91, 92, 93	Not assigned
Internal digital output 43, 44, 45	Relay 5: "Motor temperature trip"
Internal digital output 46, 47	Relay 6: "Automatic mode (normal)"
Internal digital output 48, 49	Relay 7: "Speed 0"
Internal analog output 64, 65	Torque
Internal analog output 66, 67	Power

NAMUR-compliant assignment of inputs/outputs

The table below provides an overview of the pre-assignment function of interfaces in the pin assignments for the "NAMUR" application.

Signal designation	Function
Internal digital input 19, 20	+24 V DC; forced inverter inhibit
Internal digital input 6	Rapid stop global 1
Internal digital input 7	Separately driven fan of motor activated
Internal digital input 17, 18	Forced power supply disconnection
Internal digital input 21	External fault
Internal digital input 22	External warning
Internal digital input 23	Operation, bus
Internal digital input 24	Controller ON
Internal digital input 25	Fixed setpoint 1
Internal digital input 26	Fixed setpoint 2
Internal PTC thermistor input 90, 91, 92, 93	Not assigned
Internal digital output 43, 44, 45	Relay 5: "Motor temperature trip"
Internal digital output 46, 47	Relay 6: "Automatic mode (normal)"
Internal digital output 48, 49	Relay 7: "Speed 0"
Internal analog output 64, 65	Torque
Internal analog output 66, 67	Power

SINAMICS G180

Option descriptions

Standard options

Options

4

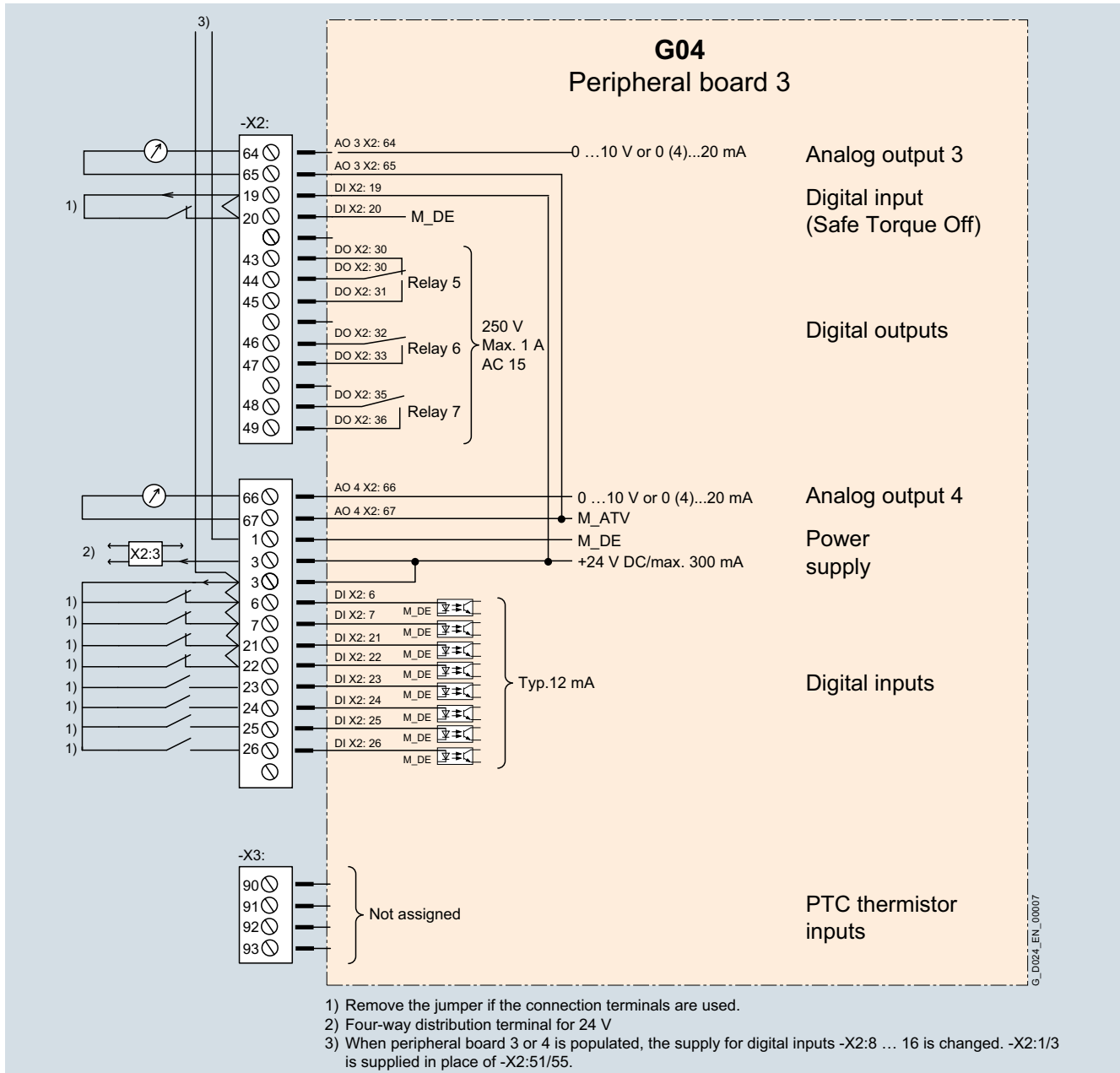

G04 Circuit diagram for peripheral board 3

Options

G05 Peripheral board 4

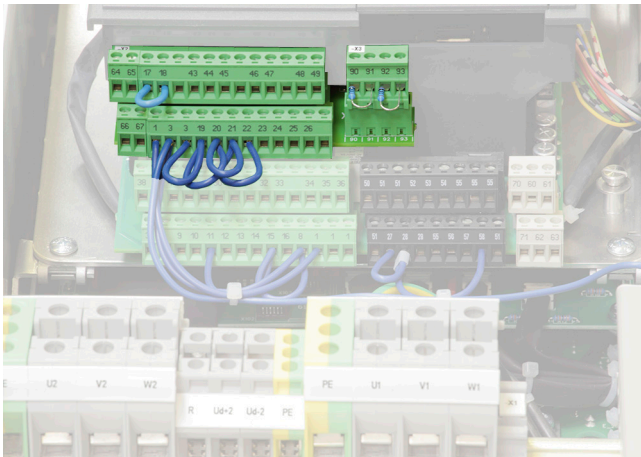

G05 Peripheral board 4 in the compact unit

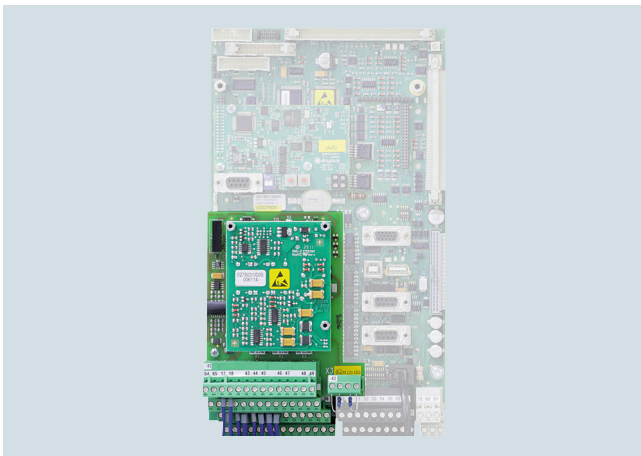

G05 Peripheral board 4 in the cabinet unit

Option **G05** (peripheral board 4) provides in addition to the standard terminals:

- 2 analog outputs (AO) 4 to 20 mA/0 to 10 V
- 2 PTC thermistor inputs, one certified for ATEX (disconnection), one warning for motor temperature monitoring of motors in a hazardous area
- One digital input "Safe Torque Off" acc. to EN ISO 13849-1, Cat. 3/(STO) implemented according to SIL 2 acc. to EN 61508
9 digital inputs (DI)
- 3 relay outputs (DO)
In addition, the relay outputs here are not only isolated from the converter electronics but also from each other.
- 24 V / 300 mA power supply unit
- ATEX-certified PTC thermistor monitoring without contactor through monitoring unit integrated in converter, certified to SIL 1 in accordance with EN 61508

PTC thermistor monitoring without contactor through monitoring unit integrated in converter, certified to SIL 1 in accordance with EN 61508 or Category 2, PL c in accordance with EN ISO 13849-1

The converter controller processes the signal of the peripheral board. In the event of excessive motor temperature, or the function "Safe Torque Off", the converter inhibits the firing signals of the IGBTs. The voltage supply of the driver stages is also switched off. These two switch-off paths ensure that the power

infeed to the motor is immediately interrupted. Further heating or rotation of the motor is excluded. The converter can only be reset or switched on when the motor has cooled down sufficiently. When the voltage fails, the converter safely interrupts the power infeed to the motor, because firing signals are no longer transferred. If a fault was active at the moment of power failure, the converter will also be in fault status when power is restored.

SIL 2 (acc. to EN 61508) – STO (Safe Torque Off).

Safe Torque Off (STO) function implemented according to SIL 2 to EN 61508.

The "Safe Torque Off" (STO) function has a redundant switch-off path in the converter. The implementation is performed using hardware. A relay in the power unit of the converter disconnects the power supply of the IGBT driver. A second circuit, also via hardware, produces a controller disable. Both switch-off paths are based on the closed-circuit principle, i.e. a failure of the control voltage results in shutdown of the converter.

The "Safe Torque Off" input can be implemented with either one or two channels. The board is coded for single-channel activation at the factory. If two-channel activation is required, please specify this in the order. Digital input X2:24 is reserved for the two-channel version.

Subsequent changeover from single-channel to two-channel is only permitted to be implemented by our authorized qualified personnel.

Standard assignment of inputs/outputs

The table below provides an overview of the pre-assignment function of interfaces in the pin assignments for the "Standard" application.

Signal designation	Function
Internal digital input 19, 20	24 V DC; "Safe Torque Off" acc. to EN ISO 13849-1, Cat. 3; or SIL 2 acc. to EN 61508
Internal digital input 6, 7, 21, 22, 23, 24, 25, 26	Freely parameterizable
Internal PTC thermistor input 90, 91	PTC thermistor for disconnection (ATEX-certified)
Internal PTC thermistor input 92, 93	PTC thermistor for warning
Internal digital output 43, 44, 45	Relay 5: "Motor temperature trip"
Internal digital output 46, 47	Relay 6: "Automatic mode (normal)"
Internal digital output 48, 49	Relay 7: "Speed 0"
Internal analog output 64, 65	Torque
Internal analog output 66, 67	Power

SINAMICS G180

Option descriptions

Standard options

Options

NAMUR-compliant assignment of inputs/outputs

The table below provides an overview of the pre-assignment function of interfaces in the pin assignments for the "NAMUR" application.

Signal designation	Function
Internal digital input 17, 18	Forced power supply disconnection
Internal digital input 19, 20	+24 V DC; forced inverter inhibit
Internal digital input 6	Rapid stop global 1
Internal digital input 7	Separately driven fan of motor activated
Internal digital input 21	External fault
Internal digital input 22	External warning
Internal digital input 23	Operation, bus

Signal designation	Function
Internal digital input 24	Controller ON
Internal digital input 25	Fixed setpoint 1
Internal digital input 26	Fixed setpoint 2
Internal PTC thermistor input 90, 91	PTC thermistor for disconnection (ATEX-certified)
Internal PTC thermistor input 92, 93	PTC thermistor for warning
Internal digital output 43, 44, 45	Relay 5: "Motor temperature trip"
Internal digital output 46, 47	Relay 6: "Automatic mode (normal)"
Internal digital output 48, 49	Relay 7: "Speed 0"
Internal analog output 64, 65	Torque
Internal analog output 66, 67	Power

4

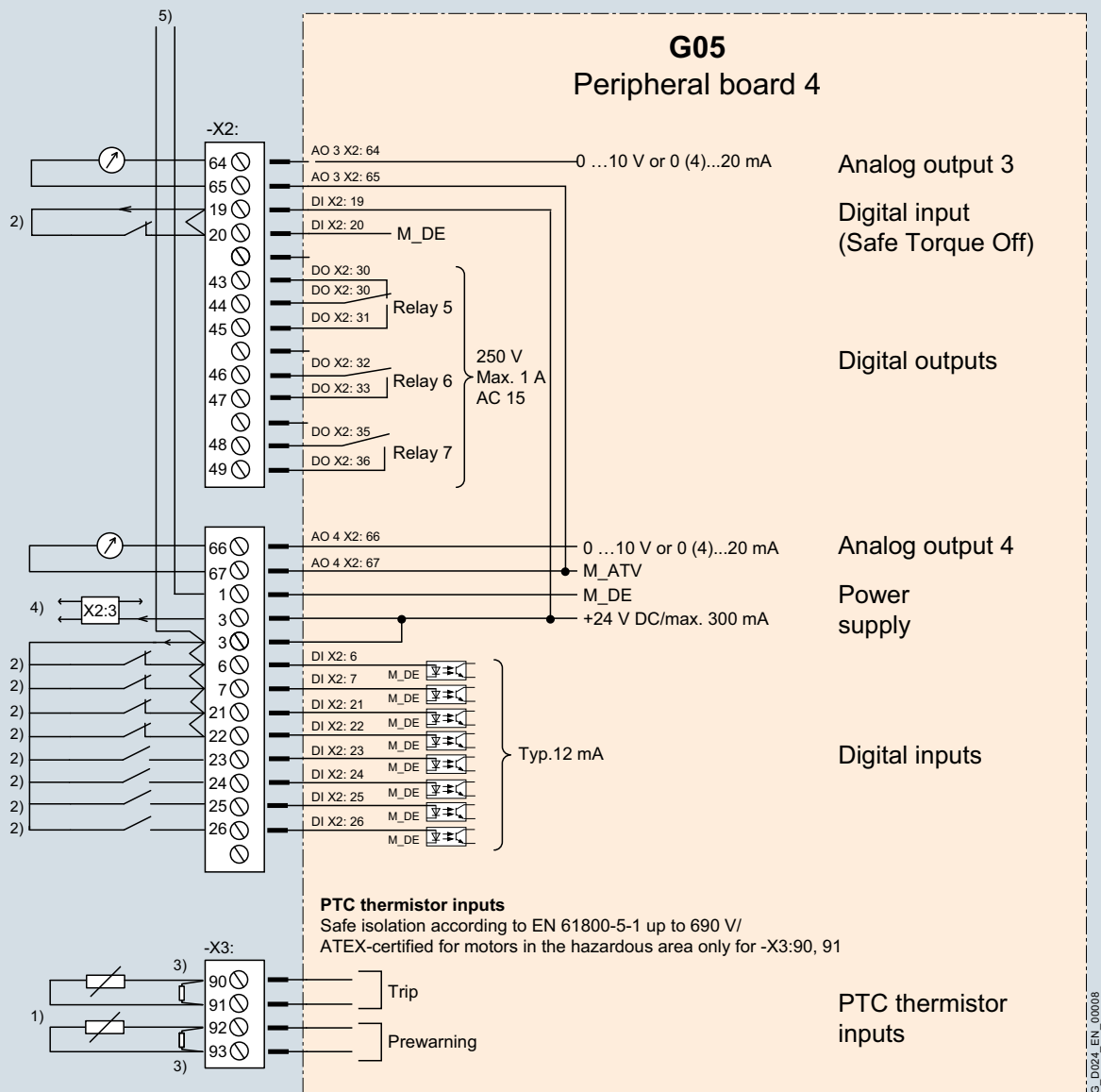

- 1) PTC inputs, suitable for motors in hazardous areas or non-hazardous areas
- 2) Remove the jumper if the connection terminals are used.
- 3) Remove the 100 Ω resistor if the connection terminals are used.
- 4) Four-way distribution terminal for 24 V
- 5) When peripheral board 3 / 4 are populated, the supply for digital inputs -X2:8 ... 16 is changed. -X2:1/3 is supplied in place of -X2:51/55.

G05 Circuit diagram for peripheral board 4

Options

G10, G11, G12, K14, K15 and K37 Control elements and display instruments in control cabinet door

Inadmissible option combinations **G10** and **G11**

Control elements and display instruments in cabinet door		G10	G11	G12	K14	K15	K37
SENTRON PAC3220 power monitoring device (without current transformer)	G10		-	✓	✓	✓	✓
SENTRON PAC3220 power monitoring device (with current transformer)	G11	-		✓	✓	✓	✓
Expansion module PROFIBUS for option G10 or G11 (SENTRON PAC3220 power monitoring device)	G12	✓	✓		-	-	-
External 4-line operator panel, supplied separately packed	K14	✓	✓	-		✓	✓
External 4-line operator panel integrated in control cabinet door	K15	✓	✓	-	✓		✓
Selector switch in form of key-operated switch	K37	✓	✓	-	✓	✓	

✓ Options are combinable.

- Options mutually exclude each other.

G10 SENTRON PAC3220 power monitoring device (without current transformer)



G10 and **G11** Line voltage display, Siemens SENTRON PAC3220

Option **G10** comprises the Siemens SENTRON PAC3220 power monitoring device without current transformer. This device is built into the cabinet door and fully wired up.

Display of:

- Line voltage
- Line frequency

Degree of protection: IP65

Dimensions (H × W × D): 96 × 96 × 58 mm

The SENTRON PAC3220 is equipped with a Modbus TCP interface as standard.

With option **G12** (PROFIBUS expansion module) the SENTRON PAC3220 can be connected to PROFIBUS.

G11 SENTRON PAC3220 power monitoring device (with current transformer)

For picture, see option **G10** "SENTRON PAC3220 power monitoring device (without current transformer)".

Option **G11** comprises the Siemens SENTRON PAC3220 power monitoring device with current transformer. This device is built into the cabinet door and fully wired up.

Display of:

- Line current
- Line voltage
- Line frequency
- Power factor
- Line harmonic THD for U and I
- Apparent power
- Reactive power
- Active power
- Apparent/reactive/active energy

Degree of protection: IP65

Dimensions (H × W × D): 96 × 96 × 58 mm

The SENTRON PAC3220 is equipped with a Modbus TCP interface as standard.

With option **G12** (PROFIBUS expansion module) the SENTRON PAC3220 can be connected to PROFIBUS.

Note:

A larger cabinet or additional cabinet may have to be planned for the current transformer.

G12 PROFIBUS expansion module for option **G10** or **G11** (SENTRON PAC3220 power monitoring device)

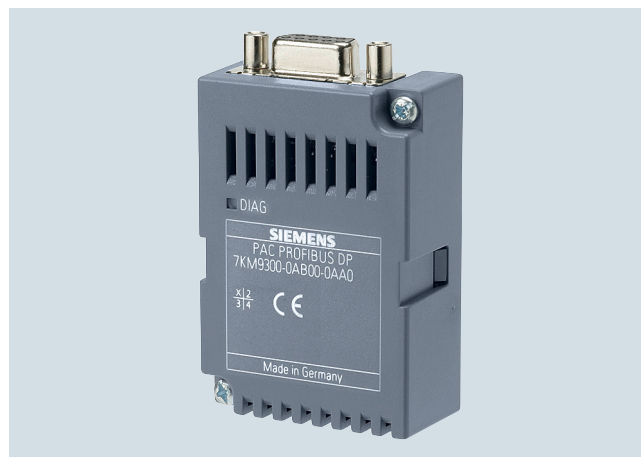

G12 PROFIBUS expansion module

Option **G12** allows the SENTRON PAC3220 power monitoring device to be connected to PROFIBUS. This expansion module can only be ordered in conjunction with option **G10** or **G11**.

SINAMICS G180

Option descriptions

Standard options

Options

K14 External 4-line operator panel, supplied separately packed

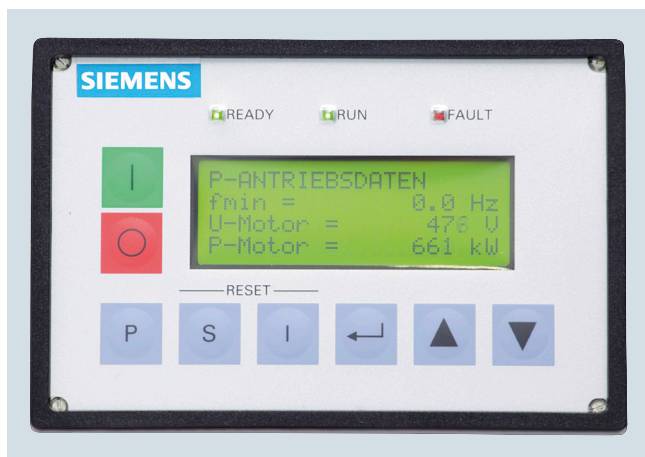

K14 and **K15** external operator panel

Compact units have an internal display. Using option **K14** an external display can be ordered that can be built into a door or operator panel by the customer (max. distance with external 24 V DC power supply: 1000 m).

Degree of protection: IP54

Dimensions (H x W x D): 96 x 144 x 61 mm

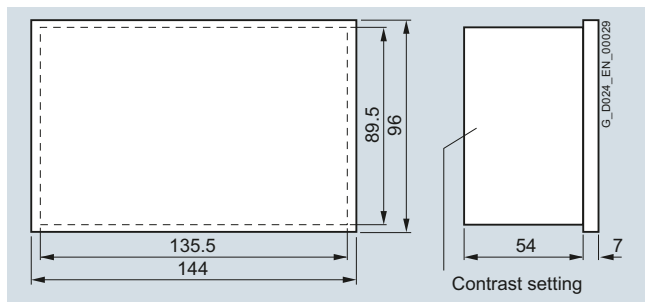

K14 Dimensional drawing of external operator panel

Note:

Without an external 24 V DC supply, the permitted length of the cable is max. 5 m (a shielded twisted-pair cable must be used as the connecting cable, e.g. LiYCY 2x2x0.25).

With option **K14** a 5 m long connecting cable is supplied.

If the cable between the converter and the operator panel is longer than 5 m, an external 24 V DC power supply unit will be required.

K15 External 4-line operator panel integrated in control cabinet door

For picture, see option **K14** "External 4-line operator panel, supplied separately packed".

Compact units have an internal display. Using option **K15** an external display can be ordered that is built into the cabinet door in the case of cabinet systems. Cabinet units generally have a display in the door.

Note:

An "internal operator panel" can be requested in place of the external operator panel (in the cabinet door of air-cooled cabinet units), see "Engineer To Order – ETO" under "Option descriptions" on Page 4/33.

K37 Selector switch in form of key-operated switch



K37 Key-operated switch (example shown)

With option **K37** the selector switches that are built into the cabinet door are implemented as key-operated switches (e.g. local/remote switches). The switches must be explicitly specified in the order.

Options

L00 and L02 RFI suppression filter

	L00	L02	L03	L04	L05	L06	L07
L00		–	✓	✓	✓	✓	✓
L02	–		–	–	–	–	–
L03	✓	–		–	–	–	–
L04	✓	–	–		–	–	–
L05	✓	–	–	–		–	–
L06	✓	–	–	–	–		–
L07	✓	–	–	–	–	–	

- ✓ Options are combinable.
- Options mutually exclude each other.

L00 RFI suppression filter Category C2 or C3 (Class A)

Option **L00** comprises an RFI suppression filter of Class A. This fulfills the following requirements:

- For compact units in a TN/TT system:
RFI suppression filter acc. to EN 55011 Class A and EMC product standard EN 61800-3 Category C2 (environment 1, public network)
- For cabinet units in a TN/TT system:
RFI suppression filter acc. to EN 55011 Class A and EMC product standard EN 61800-3 Category C3 (environment 2, industrial area)

Note:

Option **L00** is only permitted to be installed for devices that are intended for use in grounded networks, i.e. for 400 V devices (only permitted to be used in grounded systems) and for 500 V or 690 V devices that operate on a grounded line voltage.

For units in category C2 the following applies:

If not correctly installed and commissioned, this product can cause radio frequency interference in residential areas. In this case, it may be necessary for the operator of the unit to take further interference suppression measures.

L02 RFI suppression filter EN 55011 Class B

Option **L02** comprises an RFI suppression filter of Class B. This fulfills the following requirements for compact units:

RFI suppression filter acc. to EN 55011 Class B and EMC product standard EN 61800-3 Category C1 (environment 1, residential area).

Note:

Option **L02** is only permitted to be installed for devices that are intended for use in grounded networks, i.e. for 400 V devices (only permitted to be used in grounded systems) and for those that operate on a grounded line voltage.

L03 and L04

Line Harmonics Filter for cabinet units



L03 and L04 Example of a Line Harmonics Filter in the cabinet unit

L03 Line Harmonics Filter for 50 Hz line frequency

With option **L03** a Line Harmonics Filter for 50 Hz line frequency will be installed in the control cabinet for reducing the line-side harmonics or for compliance with IEEE 519. See the general technical data.

Note:

Please ask your Siemens contact person for the exact cabinet dimensions.

L04 Line Harmonics Filter for 60 Hz line frequency

With option **L04** a Line Harmonics Filter for 60 Hz line frequency will be installed in the control cabinet for reducing the line-side harmonics or for compliance with IEEE 519. See the general technical data.

Note:

Please ask your Siemens contact person for the exact cabinet dimensions.

L05, L06 and L07

Line Harmonics Filter for compact units and cabinet systems

L05 Line Harmonics Filter for operation at 380 ... 415 V 3 AC/50 Hz,
L06 Line Harmonics Filter for operation at 440 ... 500 V 3 AC/50 Hz,
L07 Line Harmonics Filter for operation at 440 ... 480 V 3 AC/60 Hz



L05, L06 and L07 Example of a Line Harmonics Filter in the converter cabinet with compact unit

The SINAMICS G180 compact units and cabinet systems equipped with either the option **L05**, **L06** or **L07** comply with the limit values of the standard IEEE 519 in terms of harmonics mitigation, on the condition that the relative short-circuit power (RSC) of the supply system is ≥ 50 . For devices with a rated power ≥ 22 kW, additionally, a THDi lower than 5% can be achieved.

Note:

The correct operating voltage has to be additionally specified.

- **L05** can be selected in combination with **V70**, **V71**, **V72** or **Y70**
- **L06** can be selected in combination with **V73** or **Y70**
- **L07** can be selected in combination with **V76**, **V77**, **V78** or **Y70**

SINAMICS G180

Option descriptions

Standard options

Options

L10, L14, L15, L16 and L17 Output filter

Inadmissible option combinations **L14, L15, L16, L17**

Output filter		L10	L14	L15	L16	L17
Strengthened dv/dt output filter	L10		✓	✓	✓	✓
Sine-wave filter in control cabinet, 75 Hz; 10 % voltage drop	L14	✓		–	–	–
Sine-wave filter in control cabinet, 60 Hz; 10 % voltage drop	L15	✓	–		–	–
Sine-wave filter IP00 supplied separately, 75 Hz; 5 % voltage drop	L16	✓	–	–		–
Sine-wave filter in control cabinet, 75 Hz; 5 % voltage drop	L17	✓	–	–	–	

✓ Options are combinable.

– Options mutually exclude each other.

L10 Strengthened dv/dt output filter for max. 250/300 m (type-dependent) – design for longer motor cables available on request



L10 Output filter (example of filter reactor)

All SINAMICS G180 converters are fitted with a dv/dt filter as standard that are suitable for motor cable lengths (depending on the power rating, see technical data) from 100 to 200 m typically. Standard motors with standard insulation can be used.

With option **L10** a strengthened dv/dt output filter is selected. The strengthened dv/dt output filter typically extends the possible motor cable length (depending on the power rating, see technical data) as follows:

- Shielded cables: 250 to 300 m (e.g. NYCWY)
- Unshielded cables: 300 to 450 m (e.g. NYY)

These cable lengths are based on worst-case conditions. If the motor cable lengths are longer in a special case, the feasibility can be checked in the factory. The cable types, their number and length must be known for this purpose.

Method of operation:

The dv/dt filter in SINAMICS G180 limits the voltage gradient (dv/dt) and the peak voltage \hat{U}_{LL} for the motor winding to the following values:

- Voltage gradient $dv/dt < 1500 \text{ V}/\mu\text{s}$
- Peak voltages \hat{U}_{LL} (typically) $< 1560 \text{ V}$

Various explosion protection regulations (ATEX) specify a maximum permissible average peak voltage at the motor (IEC 60034-25-A) of 1560 V (LHX2 motor winding) and a permissible maximum terminal voltage at the motor (explosion-proof motors only) of 1866 V.

Design:

SINAMICS G180 dv/dt filters mainly comprise a dv/dt reactor and a voltage limiting network that limits the voltage peaks.

Reduction of voltage peaks using dv/dt filters normally obviates the need for special insulation of the motors. The filter also has a positive effect on the bearing currents (reduction of bearing currents).

Voltage drop:

The voltage drop in the converter is compensated using the "Overmodulation" software function in which case the output voltage of the converter is almost equal to the input voltage.

L14 Sine-wave filter integrated in control cabinet or additional cabinet, suitable for motor frequencies of $\leq 75 \text{ Hz}$, voltage drop approx. 10 % of the line voltage

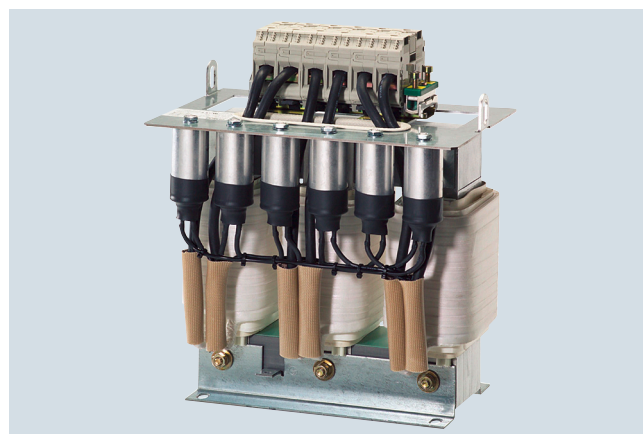

L14 Sine-wave filter (example shown)

With option **L14** a sine-wave filter for motor frequencies of $\leq 75 \text{ Hz}$ is integrated in the control cabinet.

Sine-wave filters should largely suppress the clock-frequency harmonics at the motor terminals to the extent that the voltage approximates a sinusoidal wave. They are implemented as LC networks.

Due to the large voltage drop of a sine-wave filter, it should normally be checked before it is used whether a dv/dt filter would suffice for the application case. To check this, please send the necessary data (cable length, cable type, cable cross-section, number of parallel cables) to your Siemens contact person.

Note:

The voltage drop at the sine-wave filter can cause an unacceptable temperature rise in the motor.

Voltage drop approximately 10 % of the line voltage.

The voltage drop can be compensated by using a sine-wave filter with a step-up transformer. If this is required, please ask your Siemens contact person.

The cabinet dimensions may increase as a result.

Options

L15 Sine-wave filter integrated in control cabinet or additional cabinet, suitable for motor frequencies ≤ 60 Hz, voltage drop approx. 10 % of the line voltage

With option **L15** a sine-wave filter for motor frequencies of ≤ 60 Hz is integrated in the control cabinet.

Sine-wave filters should largely suppress the clock-frequency harmonics at the motor terminals to the extent that the voltage approximates a sinusoidal wave. They are implemented as LC networks.

Due to the large voltage drop of a sine-wave filter, it should normally be checked before it is used whether a dv/dt filter would suffice for the application case. To check this, please send the necessary data (cable length, cable type, cable cross-section, number of parallel cables) to your Siemens contact person.

Note:

The voltage drop at the sine-wave filter can cause an unacceptable temperature rise in the motor.

Voltage drop approximately 10 % of the line voltage.

The voltage drop can be compensated by using a sine-wave filter with a step-up transformer. If this is required, please ask your Siemens contact person.

The cabinet dimensions may increase as a result.

L16 Sine-wave filter IP00 for compact unit, suitable for motor frequencies of ≤ 75 Hz, voltage drop of approx. 5 % of the line voltage (supplied separately packed)

With option **L16** a sine-wave filter for motor frequencies of ≤ 75 Hz is supplied separately packed with the compact unit.

Sine-wave filters should largely suppress the clock-frequency harmonics at the motor terminals to the extent that the voltage approximates a sinusoidal wave. They are implemented as LC networks.

Due to the large voltage drop of a sine-wave filter, it should normally be checked before it is used whether a dv/dt filter would suffice for the application case. To check this, please send the necessary data (cable length, cable type, cable cross-section, number of parallel cables) to your Siemens contact person.

Note:

The voltage drop at the sine-wave filter can cause an unacceptable temperature rise in the motor.

Voltage drop approximately 5 % of the line voltage.

The voltage drop can be compensated by using a sine-wave filter with a step-up transformer. If this is required, please ask your Siemens contact person.

L17 Sine-wave filter integrated in control cabinet or additional cabinet, suitable for motor frequencies ≤ 75 Hz, voltage drop approx. 5 % of the line voltage

With option **L17** a sine-wave filter for compact units and motor frequencies of ≤ 75 Hz is integrated in the cabinet system.

Sine-wave filters should largely suppress the clock-frequency harmonics at the motor terminals to the extent that the voltage approximates a sinusoidal wave.

Due to the large voltage drop of a sine-wave filter, it should normally be checked before it is used whether a dv/dt filter would suffice for the application case. To check this, please send the necessary data (cable length, cable type, cable cross-section, number of parallel cables) to your Siemens contact person.

This voltage drop can cause an unacceptable temperature rise in the motor.

Voltage drop approximately 5 % of the line voltage.

The voltage drop can be compensated by using a sine-wave filter with a step-up transformer. If this is required, please ask your Siemens contact person.

L48, L49, L50, L55, N35, N36, Y11 and Y98 Accessories

L48 Grounding socket outlet 230 V, 50 Hz, 10 A, in control cabinet with 30 mA ground-fault circuit interrupter, external incoming supply

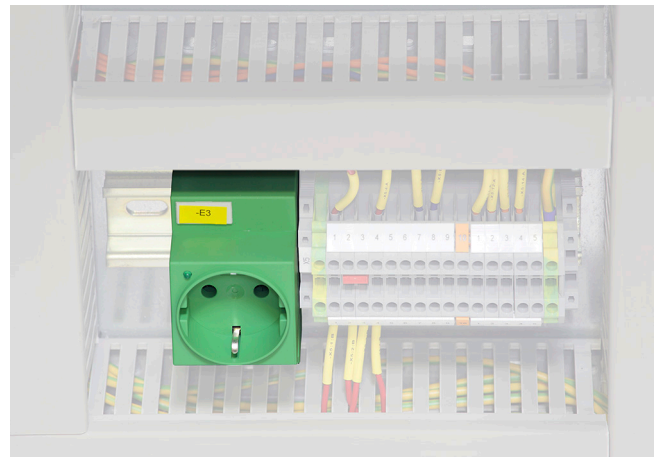

L48 Grounding socket outlet (example shown)

Option **L48** comprises one 230 V/50 Hz grounding socket outlet in the control cabinet with a 30 mA ground-fault circuit interrupter and 10 A /B miniature circuit breaker, e.g. for notebook (service).

The socket outlet is supplied from an external incoming supply provided by the customer; the terminals are provided in the converter for this.

Note:

If a plug system other than the SCHUKO grounding system is used, e.g. a British or US plug system, please specify this in the order.

SINAMICS G180

Option descriptions

Standard options

Options

L49 Grounding socket outlet 230 V, 50 Hz, 1 A, in control cabinet with 30 mA ground-fault circuit interrupter, supplied internally

Option **L49** comprises one 230 V/50 Hz grounding socket outlet in the control cabinet with a 30 mA ground-fault circuit interrupter and 1 A /C miniature circuit breaker, e.g. for notebook (service).

The socket outlet is supplied from an internal control transformer.

If a plug system other than the SCHUKO grounding system is used, e.g. a British or US plug system, please specify this in the order.

L50 Magnetically attached control cabinet light and door contact switch



L50 Control cabinet light (example shown)

The light is fitted with a fluorescent lamp (8 W) without a socket outlet. It is attached using magnets which ensures a high degree of flexibility.

The lamp is switched via a door contact and supplied via an internal control transformer. The light is installed in the control cabinet.

L55 Cabinet heater to protect against condensation and/or operation with supply air temperature of -5 °C or below



L55 Cabinet heater (example shown)

With option **L55** cabinet heaters are used with 250 W per control cabinet.

Cabinet heaters are recommended at low ambient temperatures and high levels of humidity to prevent condensation or frost damage. The number of cabinet heaters installed is determined by the number of cabinet sections.

Cabinet heaters should be used above:

- 85 % air humidity. The maximum permissible air humidity in the switchroom is 95 % (condensation is not permitted).
- -5 °C supply air during operation. The minimum ambient temperature for air-cooled converters is 0 °C in the switchroom.

The heater is controlled by a thermostat built into the control cabinet. It is supplied from the installed control voltage transformer or, if required, from an external control voltage supply.

Available as an ETO option:

- Cabinet heaters with increased output for temperatures between -5 ° and -10 °C.
- The cabinet heater is controlled by a hygrostat.

N35 Controlled outgoing feeder for motor heater, voltage 230 V 1 AC, max. 4 kW

This option is used when the driven motor is equipped with a heater that is supplied from the converter. It is important to note that the heater voltage is identical to the control voltage, normally 230 V/50 Hz.

The outgoing feeder can be controlled internally by the converter or externally.

The heater data (voltage/power) of the heater must be included in the order.

N36 Controlled outgoing feeder for external motor fan – external fan voltage for 3 AC. Converter line voltage, max. 4 kW

This option is used when the driven motor is equipped with an external fan motor that is supplied from the converter. It is important to note that the external fan voltage must be identical to the line voltage.

The outgoing feeder can be controlled internally by the converter or externally. The motor data (voltage/current) of the external fan motor must be included in the order.

Y11 Undervoltage release for main switch or circuit breaker; specify coil voltage

With option **Y11** an undervoltage release will be installed for a main switch or circuit breaker. The voltage for this release must be specified.

Application examples:

- In combination with options **S01** or **S02** and the externally backed-up control voltage of the converter, Safety Integrity Level (SIL) 3 according to EN 61508 can be achieved. There is no need for a second main contactor.
Disadvantage:
Automatic reset is not possible, because the main switch or circuit breaker must be reclosed manually. An externally backed-up control voltage is necessary.
- With an undervoltage release, Safety Integrity Level (SIL) 1 can be achieved without a main contactor and without an EMERGENCY OFF relay.
Disadvantage:
Automatic reset is not possible, because the main switch or circuit breaker must be reclosed manually. An externally backed-up control voltage is necessary.

Note:

Please specify the application case in the order.

Options

Y98 Controlled outgoing feeder for auxiliary drive up to max. 4 kW, please specify type of drive, voltage and number of phases

With option **Y98** an outgoing feeder is prepared for an auxiliary drive of up to 4 kW. Please specify the voltage and number of phases as well as the type of drive or function description.

The outgoing feeder can be controlled internally by the converter or externally.

Note:

The voltage for the auxiliary drive must be less than or equal to the line voltage.

L72

Braking chopper

L72 Braking chopper integrated into converter (braking resistor is not included and must be ordered separately)

During motor operation the electrical power flow is from the converter to the motor. During generator operation the electrical power flow is from the motor to the converter (braking of rotating masses, active loads).

The standard version of SINAMICS G180 cannot feed energy back into the system. During braking operation kinetic energy can be converted into heat loss. Approx. 10 % of the braking torque is available in the upper speed range. A braking torque up to 50 % can be achieved without a supplementary device in the mid and lower speed range through oversaturation of the motor. The braking chopper accessory allows an external braking resistor to be connected. The braking torque varies in accordance with the converter type and resistance value. The energy generated is converted to heat via the braking transistor in the braking resistor. Any questions regarding braking resistors and the maximum possible braking torque should be addressed to your Siemens contact person.

A thermal model of the braking resistor incorporated into the converter firmware protects the resistor from overload.

N39

DC link connected to terminals

The DC link terminals -X1:UD+2 and -X1:UD-2 are generally available for the compact units as well as for the cabinet systems. For all larger converters, these can be ordered via option **N39**. A DC link connection is required when a DC line-up is to be established between two converters. The DC line-up can only be used if the drive is operated in regenerative mode.

Example:

Test stand with loading device. Only the losses from the grid are covered. The regenerative energy is supplied to the motor converter via the DC link.

L80, L81, L82, L83 and Y80

ATEX certified PTC monitoring relay



L80 ATEX certified PTC monitoring relay

The ATEX certified PTC monitoring relay for monitoring motors, transformers, etc. with PTC thermistor temperature sensors to DIN 44081, especially explosion-proof motors, is certified to ATEX (Directive 2014/34/EU).

The relay in IP20 degree of protection is uniformly 22.5 mm wide and suitable for mounting on a standard rail to DIN EN 50022. The two changeover contacts can be used for disconnecting the system and for outputting alarms to a higher-level control system. The status of the monitoring circuit is signaled by LEDs for Operation (green) and Fault (red). The relay also features a LED for sensor break or sensor short-circuit.

The following generally applies:

- Thermal motor protection with ATEX certification (Directive 2014/34/EU).
- Devices with protective separation to EN 61140, EN 60947-1.
- Compliance with EN 60947-5-1, EN 60947-8, EN 60079-14, EN 61508, EN 50495, EN 13849
- Sensor circuit: max. 6 PTC thermistors (< 1.5 kΩ).
- Acknowledgment button on device and remote acknowledgment is possible.

Note:

When a PTC monitoring relay with a switch-off function is used, a line contactor must be installed on the input side (option **S01** or **S02**) for compliance with ATEX (Directive 2014/34/EU).

Such devices are used in special cases, e.g. identical design to previously supplied equipment, or for evaluating several PTC thermistors. Otherwise, for evaluating PTC thermistors, peripheral board 2 (option **G03**) or peripheral board 4 (option **G05**) must be used.

SINAMICS G180

Option descriptions

Standard options

Options

L80 ATEX certified PTC monitoring relay without storage for motor temperature prewarning

With this option, the motor prewarning temperature limit is monitored using up to 6 PTC thermistors. If the prewarning temperature is exceeded an alarm is output to the converter. The fault is not stored on the relay and therefore does not require acknowledgement.

L81 ATEX certified PTC monitoring relay with storage for motor temperature trip

With this option, the motor trip temperature limit is monitored using up to 6 PTC thermistors. If the trip temperature is reached an alarm is output to the converter. The converter switches itself off. The fault is stored on the relay and therefore has to be acknowledged.

Note:

When such devices are used for switch-off, a line contactor must be installed on the input side (option **S01** or **S02**) for compliance with ATEX (Directive 2014/34/EU).

L82 ATEX certified PTC monitoring relay without storage for transformer temperature prewarning

With this option, the transformer prewarning temperature limit is monitored using up to 6 PTC thermistors. If the prewarning temperature is exceeded an alarm is output to the converter. The fault is not stored on the relay and therefore does not require acknowledgement.

L83 ATEX certified PTC monitoring relay with storage for transformer temperature trip

With this option, the transformer trip temperature limit is monitored using up to 6 PTC thermistors. If the trip temperature is reached an alarm is output to the converter. The converter switches itself off. The fault is stored on the relay and therefore has to be acknowledged.

Note:

When such devices are used for switch-off, a line contactor must be installed on the input side (option **S01** or **S02**) for compliance with ATEX (Directive 2014/34/EU).

Apart from disconnecting the converter, it is also recommended that the already existing tripping device on site is disconnected that is connected upstream of the transformer, such as the medium-voltage switch.

Y80 ATEX certified PTC monitoring relay for other PTC thermistor temperature monitoring functions

With this option, a temperature limit is monitored using up to 6 PTC thermistors. If the temperature limit is reached an alarm is output to the converter. Please specify whether the fault should be stored on the relay and therefore has to be acknowledged or not.

L87 **Insulation monitoring**

L87 Integrated insulation monitoring system for operation on the secondary side of unit transformer in an IT system



L87 Insulation monitoring

An insulation monitor must be used if the converter is connected to a three-winding transformer. The insulation monitor IRDH 275 from Bender monitors the entire galvanically coupled circuit for insulation faults.

This option is included as standard fully wired up in the cabinet for insulation monitoring with 12-pulse and higher-pulse converters on a unit transformer that is not grounded on the secondary side.

Function:

The insulation resistance of all galvanically coupled components (converter transformer secondary winding, cables, converter, motor) is monitored by means of a measured signal that is modulated onto the line supply. If the insulation resistance is undershot, an alarm or trip message is output.

Notice:

Only ONE insulation monitoring device at a time is permitted in the entire galvanically coupled network. False tripping occurs if 2 devices are used. This option is therefore only suitable for converter operation with one converter.

Options

L90, L91, L92, L93, L94, Y90 and Y94 Pt100 evaluation unit

Inadmissible option combinations **L90, L92 and L94** as well as **L91, L93 and L94**

Pt100 evaluation units		L90	L91	L92	L93	L94	Y90	Y94
Pt100 evaluation unit for motor winding temperature, integrated in control cabinet for monitoring of 3 × Pt100 or 3 × KTY83/84 sensors.	L90		✓	–	✓	–	✓	✓
Pt100 evaluation unit for motor bearing temperature, integrated in control cabinet for monitoring of 2 × Pt100 or 2 × KTY83/84 sensors.	L91	✓		✓	–	–	✓	✓
Pt100 evaluation unit for motor winding temperature, integrated in control cabinet for monitoring 3 × Pt100 sensors; plus an analog output 0 to 10 V or 0(4) to 20 mA connected to terminals for the hottest winding temperature.	L92	–	✓		✓	–	✓	✓
Pt100 evaluation unit for motor bearing temperature, integrated in control cabinet for monitoring 2 × Pt100 sensors or 2 × KTY83/84 sensors; plus two analog outputs 0 to 10 V or 0(4) to 20 mA connected to terminals for bearing temperature.	L93	✓	–	✓		–	✓	✓
Pt100 evaluation unit for motor winding and bearing temperatures, integrated in control cabinet for monitoring 6 × Pt100 sensors; plus two analog outputs 0 to 10 V or 0(4) to 20 mA connected to terminals for the hottest winding and bearing temperatures.	L94	–	–	–	–		✓	✓
Pt100 evaluation unit for other temperature monitoring functions, integrated in control cabinet for monitoring of 3 × Pt100 or 3 × KTY83/84 sensors.	Y90	✓	✓	✓	✓	✓		✓
Pt100 evaluation unit for other temperature monitoring functions, integrated in control cabinet for monitoring 6 × Pt100 sensors; plus two analog outputs 0 to 10 V or 0(4) to 20 mA connected to terminals.	Y94	✓	✓	✓	✓	✓	✓	

✓ Options are combinable.

– Options mutually exclude each other.

L90 Pt100 evaluation unit for motor winding temperature, integrated in control cabinet for monitoring of 3 × Pt100 or 3 × KTY83/84 sensors



L90 Siemens 3RS1041-1GW50

Pt100 evaluation unit for motor winding temperature, integrated for 3 × Pt100/1000 or 3 × KTY83/84 sensors with temperature indication on evaluation unit, alarm and trip message on converter display or integrated into the group warning or group fault.

Note:

Please specify alarm and trip limits in the order for motors that are not included in the scope of supply.

L91 Pt100 evaluation unit for motor bearing temperature, integrated in control cabinet for monitoring of 2 × Pt100 or 2 × KTY83/84 sensors

Pt100 evaluation unit for motor bearing temperature, integrated in control cabinet for 2 × Pt100/1000 or 2 × KTY83/84 sensors; temperature indication on evaluation unit, alarm and trip message on converter display or integrated into the group warning or group fault.

Note:

Please specify alarm and trip limits in the order for motors that are not included in the scope of supply.

SINAMICS G180

Option descriptions

Standard options

Options

L92 Pt100 evaluation unit for motor winding temperature, integrated in control cabinet for monitoring 3 × Pt100 sensors; plus an analog output 0 to 10 V or 0(4) to 20 mA connected to terminals for the hottest winding temperature

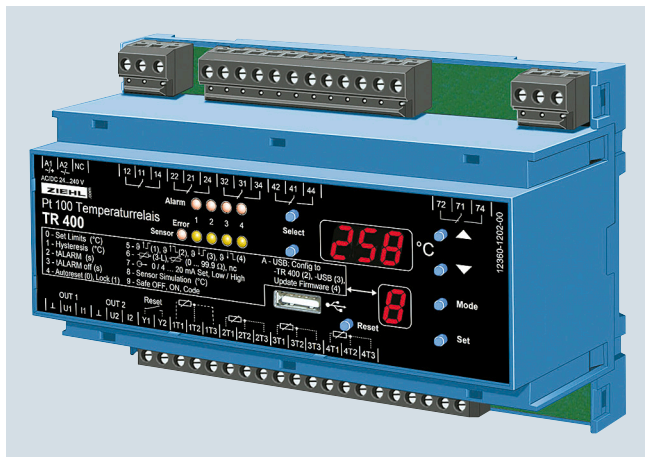

L92 Pt100 Ziehl TR400

Pt100 evaluation unit for 3 × Pt100 sensors for 3 winding sensors (1 reserve), installed in the control cabinet. With temperature indication on the evaluation unit; alarm and trip message on the converter display or integrated in the group warning or group fault.

Also one analog output 0 to 10 V or 0(4) to 20 mA for the hottest winding temperature for further processing, e.g. in the main control system; applied to terminals.

Note:

Please specify alarm and trip limits in the order for motors that are not included in the scope of supply.

L93 Pt100 evaluation unit for motor bearing temperature, integrated in control cabinet for monitoring 2 × Pt100 sensors or 2 × KTY83/84 sensors; plus two analog outputs 0 to 10 V or 0(4) to 20 mA connected to terminals for bearing temperature

Pt100 evaluation unit for 2 × Pt100 sensors or 2 × KTY83/84 sensors for motor bearing temperature, integrated in the control cabinet. With temperature indication on the evaluation unit; alarm and trip message on the converter display or integrated in the group warning or group fault.

Also two analog outputs 0 to 10 V or 0(4) to 20 mA for the bearing temperature for further processing, e.g. in the main control system; applied to terminals.

Note:

Please specify alarm and trip limits in the order for motors that are not included in the scope of supply.

L94 Pt100 evaluation unit for motor winding and bearing temperatures, integrated in control cabinet for monitoring 6 × Pt100 sensors; plus two analog outputs 0 to 10 V or 0(4) to 20 mA connected to terminals for the hottest winding and bearing temperatures

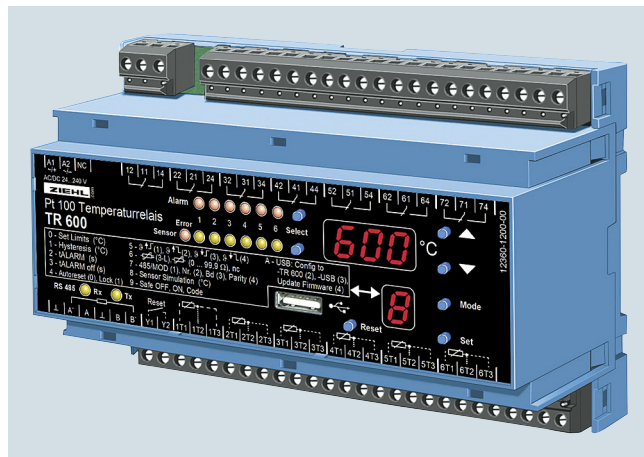

L94 Pt100 Ziehl TR600

Pt100 evaluation unit for 6 × Pt100 sensors for 3 winding sensors and 2 bearing sensors (1 reserve), integrated in the control cabinet; temperature indication on evaluation unit; alarm and trip message on converter display or integrated into the group warning or group fault.

Also one analog output 0 to 10 V or 0(4) to 20 mA for the hottest winding temperature and one analog output 0 to 10 V or 0(4) to 20 mA for the hottest bearing temperature for further processing, e.g. in the main control system; applied to terminals.

Note:

Please specify alarm and trip limits in the order for motors that are not included in the scope of supply.

Y90 Pt100 evaluation unit for other temperature monitoring functions, integrated in control cabinet for monitoring of 3 × Pt100 or 3 × KTY83/84 sensors

For image, see option **L90** Siemens 3RS1041-1GW50.

Pt100 evaluation unit for motor winding temperature, integrated in control cabinet for 3 × Pt100/1000 or 3 × KTY83/84 sensors; temperature indication on evaluation unit, alarm and trip message on converter display or integrated into the group warning or group fault.

Note:

Please specify alarm and trip limits or which temperatures should be monitored in the order.

Y94 Pt100 evaluation unit for other temperature monitoring functions, integrated in control cabinet for monitoring 6 × Pt100 sensors; plus two analog outputs 0 to 10 V or 0(4) to 20 mA connected to terminals

For image, see option **L94** Pt100 Ziehl TR600.

Pt100 evaluation unit for 6 × Pt100 sensors integrated in control cabinet; temperature indication on evaluation unit; alarm and trip message on converter display or integrated into the group warning or group fault.

Also two analog outputs 0 to 10 V or 0(4) to 20 mA applied to terminals.

Options

Note:
Please specify alarm and trip limits or which temperatures should be monitored in the order.

M05, M06, M07, M13, M17, M19, M24, M28, M34, M38, M39, M40, M59, M78, Y09 and Y19
Cabinet options

M05 Control cabinet base, welded and suitable for use with transport rollers in RAL 7022, height 200 mm

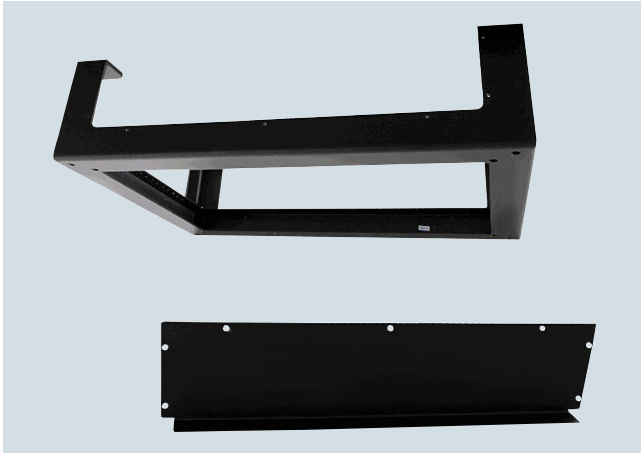

M05 Control cabinet base, welded

The control cabinet base allows larger bending radii for cables (cable inlet from below) and enables them to be routed within the control cabinet base.

The control cabinet base is welded and suitable for use with transport rollers. The standard color is RAL 7022; a special paint finish for the control cabinet base is not possible. It is delivered completely assembled with the cabinet.

Base element 200 mm painted (RAL 7022).

Note:
The control cabinet base is supplied fully assembled with the converter cabinet.

M06 Control cabinet base RAL 9005 as standard, height 100 mm



M06 Control cabinet base

The control cabinet base allows larger bending radii for cables (cable inlet from below) and enables them to be routed within the control cabinet base.

The standard color is RAL 9005; a special paint finish for the control cabinet base is not possible. The height is 100 mm.

Note:
For transport reasons, the control cabinet bases are delivered separately or packed alongside the cabinet and must be mounted on site before the cabinet is assembled.

M07 Control cabinet base RAL 9005 as standard, height 200 mm

For image, see option **M06** Control cabinet base.

The control cabinet base allows larger bending radii for cables (cable inlet from below) and enables them to be routed within the control cabinet base.

The standard color is RAL 9005; a special paint finish for the control cabinet base is not possible. The height is 200 mm.

Note:
For transport reasons, the control cabinet bases are delivered separately or packed alongside the cabinet and must be mounted on site before the cabinet is assembled.

M13 Cable entry from the top: power cable

With option **M13** the cables for mains connection will enter the control cabinet from the top.

The width of the cabinet may increase depending on the converter type and equipment. Please contact the factory regarding the exact dimensions of the converter with this option.

M34 Cable entry from the top: control cables

With option **M34** the cables for the control cables will enter the cabinet from the top.

The width of the cabinet may increase depending on the converter type and equipment. Please contact the factory regarding the exact dimensions of the converter with this option.

M78 Cable entry from the top: motor cables

With option **M78** the motor cables will enter the control cabinet from the top.

The width of the cabinet may increase depending on the converter type and equipment. Please contact the factory regarding the exact dimensions of the converter with this option.

SINAMICS G180

Option descriptions

Standard options

Options

M17 Door opening angle 180°



M17 Door opening angle 180°

With option **M17** all standard hinges are replaced with 180° hinges. The converter cabinet door can therefore normally open 180°, but the opening angle may be reduced by components installed in the control cabinet door.

M19 Window in door for viewing internal display



M19 Example of window in door for viewing internal display

With this option, an inspection window is installed in the control cabinet door. The internal converter display can be read through this.

M24 Partitions between compact units for cabinet systems



M24 Partitions between the compact units (example shown)

Partitions can be used between compact units in cabinet systems to implement clear separation of the converter with the associated controller.

M28 Door hinge on left



M28 Door hinge on left

The SINAMICS G180 converter is supplied as standard up to a cabinet width of 800 mm with the door hinged on the right (hinges on right). With this option, the doors are hinged on the left (hinges on left).

Note:

This option is not possible in the case of double doors (cabinet width 1000 mm or 1200 mm).

Options

M38 Comfort-grip handle with double-bit key lock

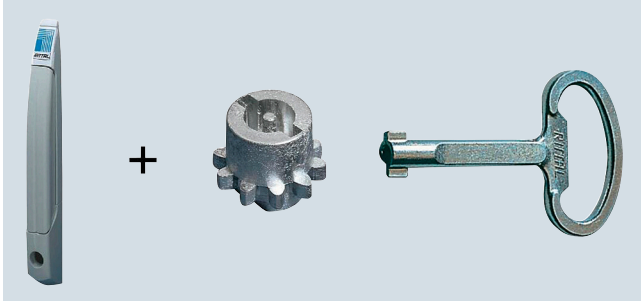

M38 Comfort-grip handle with double-bit key lock (example shown)

It is unlocked using a standard double-bit key. The unlocked handle unfolds forwards and is lifted to open the lock.

- Material: die-cast zinc
- Surface: powder-coated
- Standard version in RAL 7035

M39 Comfort-grip handle with integrated pushbutton



M39 Comfort-grip handle with integrated pushbutton (example shown)

It is unlocked using a pushbutton insert. The unlocked handle unfolds forwards and is lifted to open the lock. The cabinet door can then be opened easily without the need for additional tools.

- Material: die-cast zinc
- Surface: powder-coated
- Standard version in RAL 7035

M40 Comfort-grip handle with cylinder lock

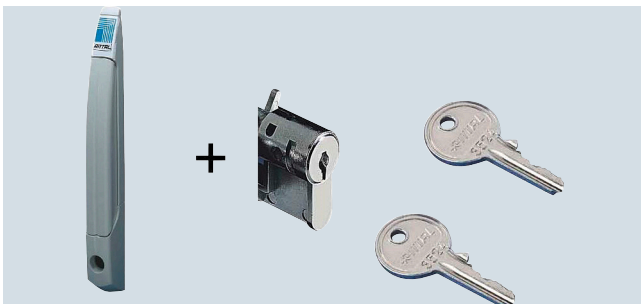

M40 Comfort-grip handle with cylinder lock (example shown)

A safety insert is used for unlocking, lock No. 3524 E with 2 keys. The unlocked handle unfolds forwards and is lifted to open the lock.

- Material: die-cast zinc
- Surface: powder-coated
- Standard version in RAL 7035

M59 Air supply via cable floor (no need for filter elements in the door)

If the converter cabinet is erected on a false floor or duct which forms part of a forced ventilation system, the converter can be ordered with closed cabinet doors. To ensure an adequate air inlet cross-section, the units are shipped without the standard base plates. In this case, the customer must ensure that no dirt/dust or moisture can enter the converter. Cables must not be routed in such a way that they impede the flow of air through the cabinet floor opening. If the area beneath the converter can be accessed, the customer must provide touch protection.

Y09 Special control cabinet paint color: Please specify RAL



Y09 Example special paint

As standard, the converter cabinet units are delivered in RAL 7035. The special paint finish must be stated in plain text in the order. All RAL colors which are available as powder coatings can be selected. This may extend the delivery time.

Important:

The protective top cover for IP21 and the protective top cover in option **M43** is supplied in RAL 7035 as standard, but it can also be painted in the special paint of the cabinet **Y09**. This must be specified in the order in which case the delivery time may be extended. If a special color is requested for the cabinet (Order code **Y09**), the top cover in option M54 is also painted in this color. The molded plastic parts (e.g. ventilation grilles) are colored RAL 7035 and cannot be painted.

SINAMICS G180

Option descriptions

Standard options

Options

Y19 Window in door for viewing internal components



Y19 Example of window in door for viewing internal components

With this option, an inspection window is installed in the control cabinet door. An internal component can be read through this.

M21, M41, M43, M54 and M63 Degrees of protection

The EN 60529 standard covers the protection of electrical equipment by means of housings, covers or equivalent, and includes:

- Protection of persons against accidental contact with live or moving parts within the housing and protection of the equipment against the ingress of solid foreign matter (touch protection and protection against ingress of solid foreign matter)

- Protection of the equipment against the ingress of water (water protection)
- Abbreviations for the internationally agreed degrees of protection

The degrees of protection are specified by abbreviations comprising the code letters IP and two digits.

Degree of protection	First digit (touch protection and protection against ingress of solid foreign matter)	Second digit (protection of the equipment against the ingress of water)
IP20 • Standard for compact units without protective top cover • Cabinet units and systems with the cabinet door open	Protected against solid foreign matter, diameter ≥ 12.5 mm	No water protection
IP21 • Option M21 for compact units • Standard for air-cooled cabinet units and systems	Protected against solid foreign matter, diameter ≥ 12.5 mm	Protected against drip water Vertically falling water drops shall not have a harmful effect.
IP41 Option M41 for cabinet units and systems	Protected against solid foreign matter, diameter ≥ 1 mm	Protected against drip water Vertically falling water drops shall not have a harmful effect.
IP43 Option M43 for cabinet units and systems	Protected against solid foreign matter, diameter ≥ 1 mm	Protected against spray water Water sprayed on both sides of the vertical at an angle of up to 60° shall not have a harmful effect.
IP54 Option M54 for cabinet units	Protected against dust Ingress of dust is not totally prevented, but dust must not be allowed to enter in such quantities that the functioning or safety of the equipment is impaired.	Protected against splash water Water splashing onto the enclosure from any direction shall not have a harmful effect.
IP55	Protected against dust Ingress of dust is not totally prevented, but dust must not be allowed to enter in such quantities that the functioning or safety of the equipment is impaired.	Protected against jet-water Water splashing onto the enclosure from any direction (nozzle) shall not have a harmful effect.

The devices are intended for indoor installation and are suitable for climatic environmental conditions of Class 3K3 according to EN 60721, higher requirements fulfilled on request.

Note:

For transport reasons, the top covers are delivered separately and must be fitted on site.

The protective top cover for IP21 and the protective top cover in option **M43** is supplied in RAL 7035 as standard, but it can also be painted in the special paint of the cabinet **Y09**. This must be specified in the order in which case the delivery time may be extended. If a special color is requested for the cabinet (Order

code **Y09**), the top cover in option **M54** is also painted in this color. The molded plastic parts (e.g. ventilation grilles) are colored RAL 7035 and cannot be painted.

Options

M21 Increased degree of protection IP21 for compact units

With option **M21** a protective top cover is supplied separately packed for the compact units. The top cover is 5 mm wider on both sides than the converter. This clearance must be taken into account when installing side-by-side. The air discharge area must be left clear at the front.

M41 Increased degree of protection IP41 for air-cooled cabinet units and systems

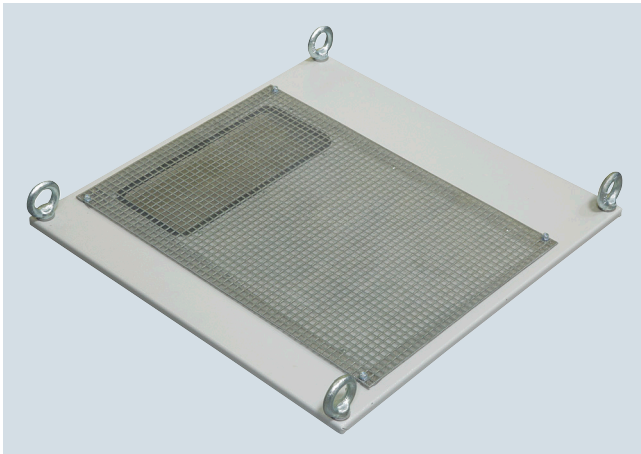

M41 Fine-mesh wire grid (example shown)

With option **M41** the filter fan or outlet filter is covered with a fine-mesh wire grid in addition to the IP21 top cover.

M43 Increased degree of protection IP43 for air-cooled cabinet units and systems

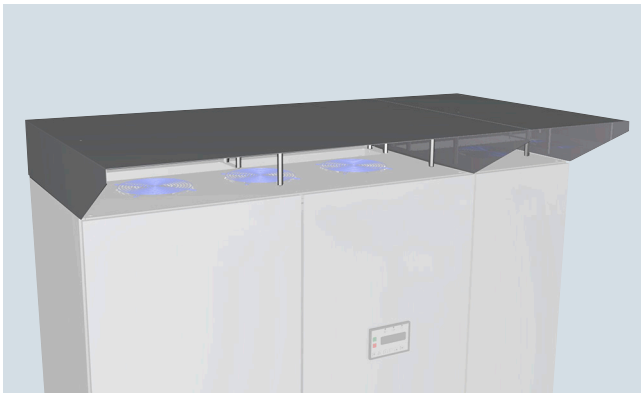

M43 IP43 top cover (example shown)

With option **M43** IP43 degree of protection is achieved using the following combination:

- Top cover IPX3 + fine-mesh wire grid in the filter fan or outlet filter

M54 Increased degree of protection IP54 for air-cooled cabinet units and systems (not suitable for outdoor applications)



M54 Labyrinth top cover (example shown)

With option **M54** IP54 degree of protection is achieved using the following combination:

- Labyrinth top cover + filter mat (open-cell polyurethane foam) in filter fan or outlet filter
- For higher outputs, filter fans are also (installed) on the side panel and rear panel. An additional minimum clearance to the panel of 300 mm has to be observed.
- With option **M63** (air flange for connection to customer's exhaust air systems; air outlet IP00) + filter mat (open-cell polyurethane foam) in filter fan or outlet filter

M63 Air flange for connection to customer's exhaust air systems (air outlet IP00)



M63 Air flange (example shown)

With option **M63** an air flange is provided on the converter. This allows the SINAMICS G180 to be connected to an external exhaust air system so that IP54 degree of protection is achieved.

Important:

For transport reasons, the air flanges are delivered separately and must be fitted on site.

Standard options

Options

M20 and N50
Wiring options**M20** Minimum cross-section of the internal cabinet wiring
1.5 mm²

With option **M20** the internal wiring of the controller in the converter is implemented using a minimum conductor cross-section of 1.5 mm². Individual electronics leads, such as flat ribbon cables are excluded from this.

N50 Use of halogen-free cables inside cabinet

With option **N50** halogen-free cables are used. Individual electronics leads, such as flat ribbon cables are excluded from this.

Q80, Q81, Q82, Q83, Q84 and Q85
Extension of the liability for defects

Option	Description
Q80	Extension of the liability for defects period by 12 months to a total of 24 months (2 years) after being delivered
Q81	Extension of the liability for defects period by 18 months to a total of 30 months (2½ years) after being delivered
Q82	Extension of the liability for defects period by 24 months to a total of 36 months (3 years) after being delivered
Q83	Extension of the liability for defects period by 30 months to a total of 42 months (3½ years) after being delivered
Q84	Extension of the liability for defects period by 36 months to a total of 48 months (4 years) after being delivered
Q85	Extension of the liability for defects period by 48 months to a total of 60 months (5 years) after being delivered

Conditions for an extension of the liability for defects:

- The liability for defects period can be extended only once, i.e. it is not possible to extend an extension. If a product has already been delivered, an extended liability for defects period can only be ordered if the original liability for defects period has still not expired.
- The scope of services provided by an extended liability of defects period includes all material and work expenditure by Siemens for rectification of the damage and, where applicable, all travel costs and expenses.
- For all extension periods of liability for defects, when ordering a new product and when reordering, the final destination of the product must be known (region in which the equipment will be finally installed). Please contact your Siemens representative for the purpose of providing this information.
- The general storage conditions described in the operating instructions must be adhered to, especially the specifications for long-term storage. These specifications must be requested separately from Siemens if necessary.
- Commissioning must be performed by appropriately qualified personnel. When making liability for defect claims, under certain circumstances, it may be necessary to submit the commissioning report to the department making the decision.
- For all liability of defect extensions, all of the regular maintenance intervals must be complied with according to what is specified in the operating instructions. When ordering the appropriate maintenance, this must be carried out by Siemens or by personnel authorized by Siemens. The corresponding maintenance documentation and history must be submitted when making liability for defect claims.
- The operating conditions correspond to the specifications and data provided in the operating instructions, in the engineering manual or special conditions specified in the specific contract.
- The extended liability for defects excludes wearing parts such as fans or filters. This does not apply if it can be clearly proven that the failure is a premature one.
- Otherwise, the general conditions regarding liability for defects applies as agreed in the delivery contract.

Options

S01, S02, S03, S04, S06, S08, S09, S11, S12, S21, S22, S23, S24, S31, S32, S41 and G08
Standard accessories packages

Standard accessories packages	Option																
Accessories package S01 with main switch, line contactor, EMERGENCY OFF pushbutton and safety relay, board G03, local/remote switch																	S01
Accessories package S02 with circuit breaker, line contactor, EMERGENCY OFF pushbutton and safety relay, board G03, local/remote switch																	S02
Accessories package with main switch, line contactor, board G03, local/remote switch																	S03
Accessories package with circuit breaker, line contactor, board G03, local/remote switch																	S04
Accessories package with main switch, line contactor, ATEX certified PTC monitoring relay, RCU box connection																	S06
Bypass for smooth line synchronization (soft start function) incl. line-side main switch and contactors at the converter output and in bypass																	S08
Bypass for smooth line synchronization (soft start function) incl. line-side circuit breaker and contactors at the converter output and in bypass																	S09
Accessories package S11 with line-side main switch, board G03, local/remote switch																	S11
Accessories package S12 with line-side circuit breaker, board G03, local/remote switch																	S12
Bypass with line-side main switch, contactors at converter output and in bypass, switchover between manual and automatic, local/remote switch																	S21
Bypass with line-side circuit breaker, contactors at converter output and in bypass, switchover between manual and automatic, local/remote switch																	S22
Bypass with line-side main switch, contactors at converter output and in bypass, EMERGENCY OFF safety relay, switchover between manual and automatic, local/remote switch																	S23
Bypass with line-side circuit breaker, contactors at converter output and in bypass, EMERGENCY OFF safety relay, switchover between manual and automatic, local/remote switch																	S24
NAMUR accessories package with Test/Normal operation switch, option G05, terminal strip compliant with NAMUR NE37 (without main switch/main contactor)																	S31
NAMUR accessories package with Test/Normal operation switch, main switch, line contactor, option G05, terminal strip compliant with NAMUR NE37																	S32
Option description																	
4-line display in the door	✓	✓	✓	✓	✓	✓	✓	✓	✓	✓	✓	✓	✓	✓	✓	✓	✓
Main switch as switch disconnecter incl. lockable door handle (for input current > 125 A also with short-circuit release)	✓				✓				✓				✓				✓
Circuit breaker with adjustable overcurrent release and short-circuit release incl. lockable door handle				✓			✓		✓						✓		✓
Main contactor on input for safety-related line disconnection	✓													✓	✓	✓	✓
EMERGENCY OFF safety relay according to EN ISO 13849-1 or SIL 1 ¹⁾ according to EN 61508	✓			✓		✓											✓
EMERGENCY OFF pushbutton and EMERGENCY OFF reset in the cabinet door	✓			✓		✓											✓
Selector switch for local/remote operation in the cabinet door				✓	✓	✓	✓	✓	✓	✓	✓			✓	✓	✓	✓
Output-side converter contactor				✓	✓	✓	✓				✓	✓					
Bypass contactor				✓	✓	✓	✓				✓	✓					
Hardware for line voltage measurement and synchronizer via the converter											✓	✓					
Input-side disconnection possibility for the converter	✓			✓	✓	✓	✓	✓						✓	✓	✓	
Motor monitoring also in bypass mode				✓	✓	✓	✓										
Manual or automatic bypass switchover				✓	✓	✓	✓										
Button "Bypass On" with lamp "Bypass On"				✓	✓	✓	✓										
Button "Bypass Off"				✓	✓	✓	✓										
Button "Reset motor fault" with lamp "Motor fault"				✓	✓	✓	✓										
Terminal strip in accordance with NAMUR recommendation NE37	✓	✓															
Selector switch for Test/Normal operation in the cabinet	✓	✓															
Peripheral board 2 (G03) incl. ATEX-certified PTC input (G03)										✓	✓	✓	✓		✓	✓	✓
Peripheral board 4 (G05) incl. automatic supply disconnection, executed in accordance with EN ISO 13849-1 up to Cat. 3 and ATEX-certified PTC input	✓	✓															

¹⁾ SIL 2 available with option **G08**, SIL 3 on request.

SINAMICS G180

Option descriptions

Standard options

Options

S41 Main switch integrated into compact unit
(might alter dimensions of unit)

With option **S41** compact units can be optionally fitted with a main switch as a switch disconnecter. The handle can be operated and locked from the outside.

G08 Peripheral board 4 (**G05**) instead of peripheral board 2 (**G03**) (only in combination with package **S01, S02, S03, S04, S08, S09, S11, S12**)

T01 and Y33

Label for plant identification



T01 Example of a label

T01 Cabinet designation TAG/ITEM number according to ordering data

Resopal labels (white with black lettering) for identifying the converter are available. The labels are screwed onto the cabinet door. Please specify the TAG/ITEM number in the order.

Dimensions 450 × 300 mm max.

Y33 Customized labels

The converter cabinets are labeled with customer-specific text (e.g. "Pump No. 1").

The text and number of labels must be specified in plain text. The labels are supplied as standard in Resopal with black lettering on a white background. The labels are screwed onto the cabinet door.

Dimensions 450 × 300 mm max.

T23, T24, T25, T26, T58, T60, T74, T76, T82, T85, T86 and Y14
Converter display language (language 1/language 2)

Different languages are available for the 4-line converter display of the SINAMICS G180. Two languages can be parameterized via the IMS. The language is switched on the display under the menu item "P-EXTRAS/Language" or by pressing down the button S for 2 seconds.



T74 Example: German display/**T76** English display

Option Description

T23	Display language Norwegian/English
T24	Display language Swedish/English
T25	Display language Czech/English
T26	Display language Hungarian/English
T58	Display language French/English
T60	Display language Spanish/English
T74	Display language German/English
T76	Display language English/German
T82	Display language Portuguese/English
T85	Display language Russian/English
T86	Display language Polish/English
Y14	Second display language other than English

U04

EAC certificate

With option **U04** a converter design is supplied with EAC conformity.

An EAC certificate is not generally required for frequency converters. An EAC negative certificate is issued as standard for a SINAMICS G180 to be exported to Russia. This confirms that the product is not subject to mandatory EAC certification.

Voluntary certification (EAC certificate) is, however, recommended for the following reasons:

- It simplifies customs clearance
- Certification on a voluntary basis increases the sales opportunities on the Russian market, because the consumer trusts certified goods.
- Voluntary certification is required in some cases on the Russian market (in retail, construction industry, etc.).
- Accredited certification bodies guarantee, with their signatures, conformity of the certified goods with Russian standards.
- An attested and signed copy of the EAC certificate must be presented for every delivery to the Russian federation for customs clearance. It is also required for subsequent sales/marketing within the country.

Options

H80, H81, H82, H83, H84, H85 and H86

Cabinet widths for cabinet systems with compact units

Option	Description
H80	Cabinet width: 406 mm
H81	Cabinet width: 606 mm
H82	Cabinet width: 806 mm
H83	Cabinet width: 1006 mm
H84	Cabinet width: 1206 mm
H85	Cabinet width: 1406 mm
H86	Cabinet width: 1606 mm

H90, H91, H92, H93 and H94

Additional cabinets for cabinet units

Option	Description
H90	Additional cabinet: 400 mm
H91	Additional cabinet: 600 mm
H92	Additional cabinet: 800 mm
H93	Additional cabinet: 1000 mm
H94	Additional cabinet: 1200 mm

V61, V62 and V63

Ambient temperature for air-cooled converters

The maximum permissible coolant temperature is 40 °C for air-cooled units. If operation is required with higher coolant temperatures, derating is necessary.

Option	Description
V61	45 °C ambient temperature (with corresponding derating)
V62	50 °C ambient temperature (with corresponding derating)
V63	55 °C ambient temperature (for compact units with corresponding derating)

V86, V87, V88 and V89

Installation altitude

At an installation altitude for the SINAMICS G180 of over 1000 m above sea level, reduced cooling caused by the lower air pressure and cosmic radiation means that the input voltage must be reduced (see the section "Characteristic curves" under "Configuring instructions"). Options **V86** to **V89** specify the installation altitude of the converter.

Option	Description
V86	Installation altitude max. 1500 m above sea level (with corresponding derating)
V87	Installation altitude max. 2000 m above sea level (with corresponding derating)
V88	Installation altitude max. 2500 m above sea level (with corresponding derating)
V89	Installation altitude max. 3000 m above sea level (with corresponding derating)

V70, V71, V72, V73, V74, V75, V76, V77, V78, V79, V80 and Y70

Line voltages

Options V70 to Y70 are used to select the line voltage. These options mutually exclude each other.

Option	Description
V70	Line voltage 380 V, 50 Hz ¹⁾
V71	Line voltage 400 V, 50 Hz
V72	Line voltage 415 V, 50 Hz ¹⁾
V73	Line voltage 500 V, 50 Hz
V74	Line voltage 660 V, 50 Hz ¹⁾
V75	Line voltage 690 V, 50 Hz
V76	Line voltage 440 V, 60 Hz ¹⁾
V77	Line voltage 460 V, 60 Hz ¹⁾
V78	Line voltage 480 V, 60 Hz ¹⁾
V79	Line voltage 600 V, 60 Hz ¹⁾
V80	Line voltage 660 V, 60 Hz ¹⁾
Y70	Special line voltage; please specify voltage ¹⁾

Y13

Language of manual

Y13 Different languages for manual

The following languages are available for the manual:

- Bulgarian
- German
- English
- Spanish
- Finnish
- French
- Hungarian
- Italian
- Dutch
- Polish
- Russian
- Norwegian

Note:

Other languages on request.

¹⁾ This line voltage is only available for SINAMICS G180 cabinet systems and SINAMICS G180 cabinet units.

SINAMICS G180

Option descriptions

Inspection options

Options

F71

Inspections for converters

In general, every converter that leaves the factory is subjected to a routine test under load conditions. The converter is therefore preparameterized. This assures the high quality standards of every SINAMICS G180 converter. Option **F71** also allow further tests to be performed, also with the customer present.

We can offer further tests under no-load conditions on request that are not included in the respective inspections at an additional charge. It is important to note that if the scope of the tests change, the prices for the individual inspections can change significantly, which is why we request prior consultation with the factory.

Inspections for converters	Option
Routine test under no-load conditions with the customer present	F71
Option description	
<ul style="list-style-type: none"> • Check of the mechanical system and the touch protection • Check for completeness • Check of equipment (components) • Check of cables • Check of customer documentation • Check of power supply • Check of fans • Check of equipment identifier • Precharging test • Function check of the converter control • Function check of protective and monitoring devices (simulation) • Function check of the customized control 	✓
Submission of the inspection report	✓
With customer present	✓

Options

Engineering

In addition to the standard options, for SINAMICS G180 converters, the option "Engineer To Order" (ETO) can also be ordered. These ETO orders are then specially defined and engineered to suit customer requirements. They cannot be ordered using the electronic ordering tools, but only on request through a Siemens contact:

X30 mechanical

e.g. cabinet dimensions with special height = 1800 mm

X40 parameterization

e.g. parameterization of additional monitoring functions: overspeed, underspeed

X50 electrical (output, controller)

e.g. special monitoring devices, safety-related standstill monitoring of motor speed

X51 extended overvoltage range

- For compact units:
 - 400 V supply with 400 V compact units:
These converters can be operated up to 500 V + 10 % as standard. These converters are therefore suitable as standard for ZLU use. If the overvoltage has been agreed as $1.4 \times U_r$, the parameter UD-MAXFAKT simply has to be set to 140 %.
 - 500 V supply with 500 V compact units:
The 690 V devices must be selected for this purpose. The power rating must normally then be increased to the next level. The parameter U mains nom. must be set to 500 V. UD-MAXFAKT must be set to the agreed value (125 to 140 %).
 - 690 V supply with 690 V compact units:
These devices can be operated for a short time at an overvoltage of $1.3 \times U_r$.
- For cabinet units:
 - 400 V supply with cabinet units:
The 500 V devices must be selected for this purpose. The power rating must normally then be increased to the next level. The parameter U mains nom. must be set to 400 V. UD-MAXFAKT must be set to the agreed value (125 to 140 %).
 - 500 V supply with 500 V cabinet units:
The 690 V devices must be selected for this purpose. The power rating must normally then be increased to the next level. The parameter U mains nom. must be set to 500 V. UD-MAXFAKT must be set to the agreed value (125 to 140 %).
 - 690 V supply with 690 V cabinet units up to 710 kW:
These devices can be operated for a short time at an overvoltage of $1.3 \times U_r$.
 - 690 V supply with 690 V cabinet units from 800 to 1000 kW:
This converter output is achieved by interconnecting converters with lower outputs (multi-system converter). The devices can then be operated for a short time at an overvoltage of $1.3 \times U_r$.

More detailed information can be obtained from your Siemens sales partner.

X60 test bay converter

e.g. engineering of a motor test bay

X70 special tests

e.g. special tests, such as vibration

X80 special documentation

e.g. documentation in a special CAD system

X90 special version

When the scope cannot be clearly assigned to one of the already listed options.

SINAMICS G180

Notes

4

Configuring instructions

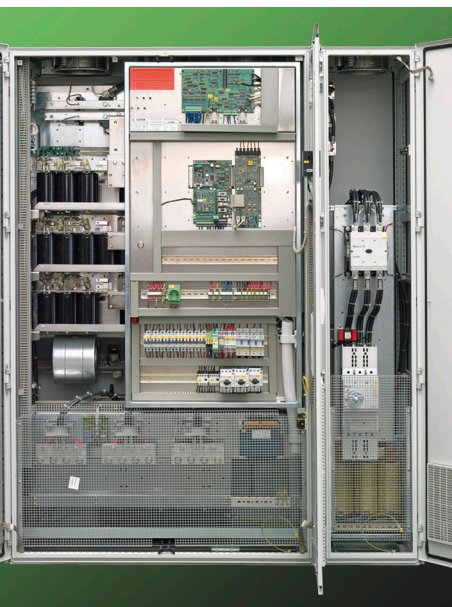

5/2	Functions
5/2	Overview
5/2	Communication with higher-level control and customer terminal strip
5/2	Open-loop and closed-loop control functions
5/2	Software and protective functions
5/3	Safety Integrated functions
5/5	Characteristic curves
5/5	Overview
5/5	Derating data
5/6	Overload capability
5/7	Cable cross-sections and connections
5/7	Overview
5/13	Converter connection for different pulse numbers
5/13	Required cable cross-sections for line and motor connections
5/14	Grounding and PE conductor cross-section
5/15	Standard interface
5/15	Overview
5/16	Standard assignment of inputs/outputs
5/16	NAMUR-compliant assignment of inputs/outputs
5/17	Communication possibilities
5/17	Overview
5/17	Operating principle
5/18	The SINAMICS G180 type plate
5/18	Overview
5/19	ZLU – Supplementary Supply Agreements for Converter Drives in Power Plants
5/19	Overview
5/20	SIZER for Siemens Drives engineering tool
5/20	Overview
5/20	System requirements
5/20	Selection and ordering data
5/20	More information
5/21	Siemens Product Configurator
5/21	Overview
5/21	Siemens Product Configurator at a glance
5/21	Access to the Siemens Product Configurator
5/22	IMS commissioning tool
5/22	Overview
5/2	Functions
5/22	Integration
5/23	Selection and ordering data
5/23	Accessories

SINAMICS G180

Configuring instructions

Functions

Overview

Communication with higher-level control and customer terminal strip

A terminal strip compliant with NAMUR recommendation NE37 is provided as standard for the customer interface. PROFINET, PROFIBUS DP, Modbus RTU, Modbus TCP and CANopen interfaces are also available.

The NAMUR-compliant customer terminal strip can be used to connect the converter to the higher-level controller using analog and digital signals, or to connect additional units.

To simplify configuring and commissioning of the drive, various applications can be selected and modified in the frequency converter. The unit can also be parameterized individually at the factory prior to delivery.

Further information and guidance are available in the IMS.

Open-loop and closed-loop control functions

The SINAMICS G180 converter can be operated in different control modes:

- Closed-loop control of the speed or torque of a drive by appropriate machine commutation. In "space-vector control" mode (SVC), the converter utilizes an optimized voltage/frequency ratio. To meet the requirements of dynamic applications, machine commutation can be combined with a tachogenerator to implement "field-oriented control" (FOC).
- Closed-loop control of current or voltage at the converter output. This mode of control does not involve machine commutation. The output frequency and the current or the voltage are specified as setpoints and implemented in the converter (within the tolerances of the unit).

Thanks to the integrated process controller, it is possible to control a wide range of process variables in different control modes.

Software and protective functions

The software functions available as standard are described below:

Software and protective functions	Description
Setpoint inputs	Setpoints can be input both internally and externally, i.e. internally as a fixed setpoint or motorized potentiometer setpoint and externally via the communications interface or an analog input on the customer terminal strip. The internal fixed setpoint and the motorized potentiometer setpoint can be switched over or adjusted using control commands via all interfaces.
Autotuning function	Thanks to the autotuning function (automatic measurement of the motor stator resistance), the closed-loop drive control can be commissioned and optimized faster and more easily.
Random pattern	Pulse pattern generation with or without random pattern can be selected. The purpose of this function is to prevent dominant clock frequency noise in the motor.
Ramp-function generator	A convenient ramp-function generator with separately adjustable and switchable ramping times, together with adjustable and switchable rounding times in the lower and upper speed ranges (transition roundings 1 to 4), allows the drive to be smoothly accelerated and braked. As a consequence, this avoids the drive train from being overloaded and reduces the stress on mechanical components. The down ramps can be parameterized separately for quick stop. In addition, all parameters can be switched over for special operating ranges.
Overvoltage controller	The overvoltage limiting controller automatically prevents overvoltages in the DC link if the down ramp is too short, for example. This may also extend the set ramp-down time.
Mains supply backup	In the event of supply voltage dips, the kinetic energy of the rotating drive is used to buffer the DC link so as to prevent fault trips. The converter remains operational as long as the drive can provide regenerative energy as a result of its motion and the DC link voltage does not drop below the trip threshold. When the line supply recovers within a parameterizable time, the drive is again accelerated up to its setpoint speed.
Undervoltage behavior	The operational performance of the frequency converter under line undervoltage conditions can be influenced to a large extent. The automatic restart function switches the drive on again when the power is restored after a power failure, and ramps up to the current speed setpoint. The automatic restart function is successful only if the power failure does not last longer than the parameterized T restart time.
Synchronization	It is possible to synchronize the SINAMICS G180 converter with a motor that is still turning and to accelerate the motor to the specified setpoint.
Slip compensation	An automatic slip compensation function improves the speed accuracy of drives that are not equipped with a speed encoder.
Process control	The integrated process controller can be used to implement simple control functions, e.g. level control or volumetric flow control. It is designed as a PID controller with separately settable P, I and D components.
Logic elements	The "Logic elements" function can be used to generate modal signals and to combine signals using logic.
Message generators	Messages can be generated subject to predefined conditions.
Parameter switches	A parameter switch can be used to switch a parameter from its original value to an alternative value.
Automatic acknowledgement function	Fault messages can be acknowledged fully automatically if required.

Overview

Software and protective functions	Description
Display	The bilingual, four-line graphical display with membrane keyboard on the converter shows operational messages, alarms and fault messages in plain text. The converter can be operated locally by means of this display.
Event memory	A comprehensive memory function for storing the last 64 events, including actual values recorded prior to and during each event, aids the evaluation and analysis of faults.
Time synchronization and operating hours counters	Timing functions can be synchronized with an external clock via digital inputs. Two different counters, one for frequency converter operating hours and the other for fan operating hours, can supply important information to the service engineer.
Motor protection	Motor protection through evaluation of a KTY84, PTC or Pt100 temperature sensor. When a KTY84 sensor is connected, the limit values can be set for alarm or shutdown. When a PTC thermistor is connected, the system reaction to triggering of the thermistor (alarm or shutdown) can be defined.
Motor blocking protection	A blocked motor is detected and can be protected against thermal overloading by a fault trip.
Noise reduction	Optimization of the pulse pattern can minimize motor noise emissions and also reduce motor losses.
Brake optimization	An oversaturation control system is provided to ensure optimum braking performance without the need for any additional equipment. A parameterizable DC braking function is also provided to permit precise deceleration down to zero speed.
Operational reliability	In order to ensure smooth reliable operation, the converter is equipped with an automatic overload time adaptation function and stall protection implemented by a tried-and-tested current limitation control system.
Fault detection	Automatic monitoring for irregularities in operation, e.g. overspeed, underspeed or no-load. These conditions can be detected and signaled by appropriate alarms.
Fault suppression	Fault messages and fault trips initiated by fault messages can be suppressed (e.g. for smoke extraction motors).
Power unit protection	
Ground fault monitoring at output end	A ground fault at the output end is detected by a total current monitor and results in shutdown in grounded-neutral systems.
Insulation monitoring	The insulation can be monitored for ground faults on converters operating on a non-grounded power supply system.
Current asymmetry monitoring at output end	A current symmetry monitoring system detects hazardous current unbalances and initiates a fault trip if necessary.
Electronic short-circuit protection at the output end	A short-circuit at the output (e.g. at the converter output terminals, in the motor cable or in the motor terminal box) is detected and the converter shuts down with "fault".
Thermal overload protection	When the overtemperature threshold monitor responds, an alarm is output initially and the clock frequency is reduced. If the temperature continues to rise, the current limit values are lowered in order to reduce the thermal load. Once the cause of the fault has been eliminated (e.g. cooling has been improved), the original operating values are automatically resumed.

Safety Integrated functions

The safety functions integrated in SINAMICS G180 converters provide highly effective application-oriented protection for personnel and machinery.

When equipped with one of the options **G04**, **G05** or **G08**, SINAMICS G180 converters provide the following Safety Integrated function (terms defined according to IEC 61800-5-2):

- Safe Torque Off (STO)

The Safety Integrated function is implemented electronically and therefore offers short response times in comparison to solutions with externally implemented monitoring functions.

Legal framework

Machine manufacturers and plant constructors must ensure that their machines or plants cannot cause danger due to malfunctions apart from the general risks of electric shock, heat or radiation. In Europe, for example, compliance with the machinery directive is legally stipulated by the EU industrial safety directive.

In order to ensure compliance with this directive, it is recommended that the corresponding harmonized European standards are applied. This initiates the assumption of conformity and gives manufacturers and operators the legal security when complying with both national regulations and EU directives. The machine manufacturer uses the CE labeling to document the compliance with all relevant directives and regulations in the free movement of goods.

Safety-related standards

Functional safety is specified in various standards. EN ISO 12100 and EN ISO 14121-1, for example, are concerned with the design and risk assessment of machines. EN 62061 (only applicable for electrical and electronic control systems) and EN ISO 13849-1 define the functional and safety-related requirements of safety-oriented control systems.

The above-mentioned standards define different safety requirements that the machine has to satisfy in accordance with the risk, frequency of a dangerous situation, probability of occurrence and the opportunities for recognizing impending danger.

- EN ISO 13849-1: Categories B, 1 ... 4
- EN ISO 13849-1: Performance Level PL a ... e
- EN 62061: Safety Integrity Level SIL 1 ... 3

SINAMICS G180

Configuring instructions

Functions

Overview

Safety functions integrated in the drive with SINAMICS G180

The safety functions integrated in the SINAMICS G180 converter with option **G04**, **G05** or **G08** satisfy the requirements of:

- Category 3 according to EN ISO 13849-1
- Performance Level (PL) d according to EN ISO 13849-1
- Safety Integrity Level (SIL) 2 according to EN 61508

With additional option **S01**, **S02** or **S32**, the SINAMICS G180 also complies with the following:

- Safety Integrity Level (SIL) 3 according to EN 61508

In addition, the Safety Integrated functions of SINAMICS G180 are generally certified by independent institutes. An up-to-date list of currently certified components is available on request from your local Siemens office.

Detailed description of the Safety Integrated function

Safe Torque Off (STO) is a function that prevents the drive from restarting unexpectedly in accordance with EN 60204-1 Section 5.4. Safe Torque Off disables the drive pulses and disconnects the power supply to the motor (corresponds to Stop Category 0 of EN 60204-1). The drive is reliably torque-free. This state is also monitored internally in the drive.

STO has the immediate effect that the drive cannot provide any torque-generating energy. STO can be used wherever the drive will reach a standstill by itself due to the load torque or friction in a sufficiently short time or when "coasting down" of the drive will not have any relevance for safety.

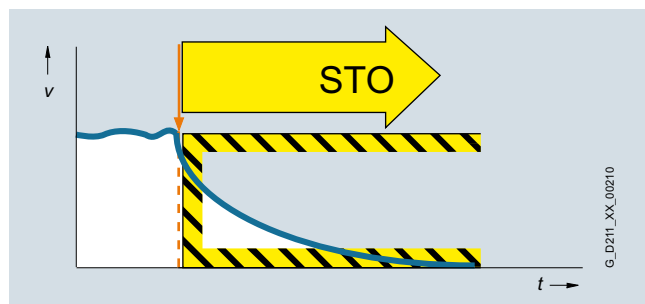

Safe Torque Off

Overview

Derating data

SINAMICS G180 converters and the associated system components are rated for an ambient temperature of 40 °C and installation altitudes up to 1000 m above sea level.

At ambient temperatures of > 40 °C, the output current must be reduced. SINAMICS G180 converters may not operate in ambient temperatures in excess of 50 °C except for compact units (up to 55 °C; option **V63**).

At installation altitudes > 1000 m above sea level, it must be taken into account that the air pressure, and therefore air density, decreases as the height increases. As a consequence, the cooling efficiency and the insulation capacity of the air also decrease.

Derating for air-cooled converters

Installation altitude above sea level m	Current derating factor (as a % of the rated current) at an ambient/air intake temperature of 40 °C							
	20 °C	25 °C	30 °C	35 °C	40 °C	45 °C	50 °C	55 °C ¹⁾
0 ... 1000	100 %				94.4 %	87.5 %	75.0 %	62.5 %
1001 ... 1500	100 %				94.4 %	82.6 %	70.8 %	59.0 %
1501 ... 2000	100 %				88.9 %	77.8 %	66.7 %	55.6 %
2001 ... 2500 ²⁾	97.7 %		93.2 %	88.4 %	83.3 %	72.9 %	62.5 %	52.1 %
2501 ... 3000 ²⁾	95.3 %	91.2 %	87.0 %	82.5 %	77.8 %	68.1 %	58.3 %	48.6 %
3001 ... 3500 ²⁾³⁾	89.8 %	86.0 %	82.0 %	77.8 %	73.3 %	64.2 %	55.0 %	45.8 %
3501 ... 4000 ²⁾³⁾	84.4 %	80.8 %	77.0 %	73.1 %	68.9 %	60.3 %	51.7 %	43.1 %
4001 ... 4500 ²⁾³⁾	78.9 %	75.6 %	72.1 %	68.4 %	64.4 %	56.4 %	48.3 %	40.3 %
4501 ... 5000 ²⁾³⁾	73.5 %	70.4 %	67.1 %	63.6 %	60.0 %	52.5 %	45.0 %	37.5 %

The compact units are designed according to minimum air clearances at up to 2000 m above sea level, and the cabinet units according to minimum air clearances at up to 3000 m above sea level, i.e. voltage derating is not required for compact units at altitudes of 2000 m or below or for cabinet units at altitudes of 3000 m or below.

Voltage derating factor

Installation altitude above sea level m	For compact units and cabinet systems: Voltage derating factor (in % of line voltage)	For cabinet units: Voltage derating factor (in % of line voltage)
	<ul style="list-style-type: none"> • For 400 V units ⇒ $V_{max} = 500$ V • For 500 V units ⇒ $V_{max} = 500$ V • For 690 V units ⇒ $V_{max} = 690$ V 	<ul style="list-style-type: none"> • For 400 V units ⇒ $V_{max} = 415$ V • For 500 V units ⇒ $V_{max} = 500$ V • For 690 V units ⇒ $V_{max} = 690$ V
0 ... 2000	100 %	100 %
2001 ... 2500	93.4 %	100 %
2501 ... 3000	87.7 %	100 %
3001 ... 3500	81.9 %	93.9 %
3501 ... 4000	77.5 %	88.5 %
4001 ... 4500	71.9 %	82.4 %
4501 ... 5000	67.6 %	77.0 %

Due to the reduced cooling efficiency, it is necessary, on the one hand, to reduce the ambient temperature, and on the other hand, to lower heat loss in the compact unit by reducing the output current, whereby ambient temperatures lower than 40 °C may be offset to compensate.

The following table specifies the permissible output currents as a function of the installation altitude and ambient temperature (the permissible compensation between installation altitude and ambient temperatures of < 40 °C (air intake temperature at the entry to the compact unit) is taken into account in the specified values).

The values apply under the precondition that a cooling air flow through the units is ensured as stated in the technical data.

Since the air clearances in the converter cannot be changed, this factor must be taken into account in the voltage derating calculation. V_{max} is the reference value for voltage derating.

¹⁾ Applies only to compact units which are not cabinet-mounted.

²⁾ Voltage derating (see voltage derating factor) is also required for compact units at an installation altitude of > 2000 m.

³⁾ Voltage derating (see voltage derating factor) is also required for cabinet units at an installation altitude of > 3000 m.

SINAMICS G180

Configuring instructions

Characteristic curves

Overview

Overload capability

The SINAMICS G180 converters have an overload reserve of typically about 110 % to deal with breakaway torques, for example. The overload period of the potential short-time current is regulated automatically (thermal converter model), but is at least 60 s at 40 °C on condition that the converter is operated at its rated current prior to and following the period of overload. This calculation is based on a duty cycle duration of 600 s.

If larger surge loads occur, this must be taken into account when configuring. It may be necessary to select a converter in the next-higher rating class.

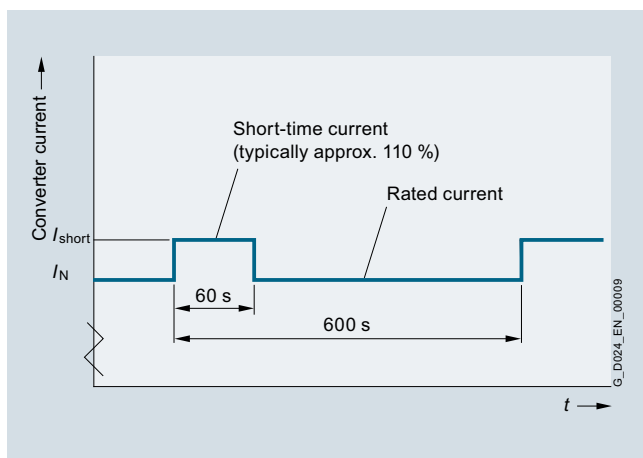

Overload capability of SINAMICS G180

Overview

Type rating	Converter	Converter type	Line connection (standard)			Line connection with main switch or circuit breaker (Options: S01, S02, S03, S04, S06, S08, S09, S11, S12, S21, S22, S23, S24, S41)			Motor connection		
			Cable cross-section solid/stranded		Fixing	Cable cross-section solid/stranded		Fixing	Cable cross-section solid/stranded		Fixing
			min. IEC mm ²	max. IEC mm ²		min. IEC mm ²	max. IEC mm ²		min. IEC mm ²	max. IEC mm ²	
SINAMICS G180 compact unit 400 V 6-pulse (230 to 500 V 3 AC TN/TT system, 50 to 60 Hz)											
2.2	6SE0100-1AC15-5AA7	2T2A-07400-002	0.2	6	Terminal	1	16	Terminal	0.2	6	Terminal
3	6SE0100-1AC17-0AA7	2T2A-07400-003	0.2	6	Terminal	1	16	Terminal	0.2	6	Terminal
4	6SE0100-1AC21-0AA7	2T2A-07400-004	0.2	6	Terminal	1	16	Terminal	0.2	6	Terminal
5.5	6SE0100-1AC21-3AA7	2T2A-07400-005	0.2	6	Terminal	1	16	Terminal	0.2	6	Terminal
7.5	6SE0100-1AC21-8AA7	2T2A-07400-007	4	16	Terminal	1	16	Terminal	4	16	Terminal
11	6SE0100-1AC21-8AA7	2T2A-07400-011	4	16	Terminal	1	16	Terminal	4	16	Terminal
15	6SE0100-1AC23-7AA7	2T2A-07400-015	0.75	35	Terminal	2.5	35	Terminal	0.75	35	Terminal
22	6SE0100-1AC24-8AA7	2T2A-07400-022	0.75	35	Terminal	2.5	35	Terminal	0.75	35	Terminal
30	6SE0100-1AC25-8AA7	2T2A-07400-030	0.75	35	Terminal	2.5	35	Terminal	0.75	35	Terminal
37	6SE0100-1AC27-8AA7	2T2A-07400-037	2.5	120	1 × M8	2.5	95	Terminal	2.5	120	1 × M8
45	6SE0100-1AC28-8AA7	2T2A-07400-045	2.5	120	1 × M8	2.5	95	Terminal	2.5	120	1 × M8
55	6SE0100-1AC31-1AA7	2T2A-07400-055	2.5	120	1 × M8	2.5	95	Terminal	2.5	120	1 × M8
75	6SE0100-1AC31-5AA7	2T2A-07400-075	2.5	120	1 × M8	2.5	95	Terminal	2.5	120	1 × M8
90	6SE0100-1AC31-8AA7	2T2A-07400-090	2.5	120	1 × M8	2.5	150	Terminal	2.5	120	1 × M8
110	6SE0100-1AC32-1AA7	2T2A-07400-110	2.5	120	1 × M8	2.5	150	Terminal	2.5	120	1 × M8
132	6SE0100-1AC32-5AA7	2T2A-07400-132	2 × 6	2 × 240	1 × M10				2 × 6	2 × 240	1 × M10
160	6SE0100-1AC33-0AA7	2T2A-07400-160	2 × 6	2 × 240	1 × M10				2 × 6	2 × 240	1 × M10
SINAMICS G180 compact unit 500 V 6-pulse (230 to 500 V 3 AC IT system, 50 to 60 Hz)											
2.2	6SE0100-1AD14-5AA7	2T2A-07500-002	0.2	6	Terminal	1	16	Terminal	0.2	6	Terminal
3	6SE0100-1AD15-5AA7	2T2A-07500-003	0.2	6	Terminal	1	16	Terminal	0.2	6	Terminal
4	6SE0100-1AD17-0AA7	2T2A-07500-004	0.2	6	Terminal	1	16	Terminal	0.2	6	Terminal
5.5	6SE0100-1AD21-0AA7	2T2A-07500-005	0.2	6	Terminal	1	16	Terminal	0.2	6	Terminal
7.5	6SE0100-1AD21-3AA7	2T2A-07500-007	0.2	6	Terminal	1	16	Terminal	0.2	6	Terminal
11	6SE0100-1AD21-8AA7	2T2A-07500-011	4	16	Terminal	1	16	Terminal	4	16	Terminal
15	6SE0100-1AD22-5AA7	2T2A-07500-015	4	16	Terminal	1	16	Terminal	4	16	Terminal
22	6SE0100-1AD23-7AA7	2T2A-07500-022	0.75	35	Terminal	2.5	35	Terminal	0.75	35	Terminal
30	6SE0100-1AD24-8AA7	2T2A-07500-030	0.75	35	Terminal	2.5	35	Terminal	0.75	35	Terminal
37	6SE0100-1AD25-8AA7	2T2A-07500-037	0.75	35	Terminal	2.5	35	Terminal	0.75	35	Terminal
45	6SE0100-1AD27-8AA7	2T2A-07500-045	2.5	120	1 × M8	2.5	95	Terminal	2.5	120	1 × M8
55	6SE0100-1AD28-8AA7	2T2A-07500-055	2.5	120	1 × M8	2.5	95	Terminal	2.5	120	1 × M8
75	6SE0100-1AD31-1AA7	2T2A-07500-075	2.5	120	1 × M8	2.5	95	Terminal	2.5	120	1 × M8
90	6SE0100-1AD31-5AA7	2T2A-07500-090	2.5	120	1 × M8	2.5	95	Terminal	2.5	120	1 × M8
110	6SE0100-1AD31-8AA7	2T2A-07500-110	2.5	120	1 × M8	2.5	150	Terminal	2.5	120	1 × M8
132	6SE0100-1AD32-1AA7	2T2A-07500-132	2.5	120	1 × M8	2.5	150	Terminal	2.5	120	1 × M8
160	6SE0100-1AD32-5AA7	2T2A-07500-160	2 × 6	2 × 240	1 × M10				2 × 6	2 × 240	1 × M10
200	6SE0100-1AD33-0AA7	2T2A-07500-200	2 × 6	2 × 240	1 × M10				2 × 6	2 × 240	1 × M10
SINAMICS G180 compact unit 690 V 6-pulse (230 to 690 V 3 AC TN/TT or IT system, 50 to 60 Hz)											
7.5	6SE0100-1A.21-0AA7	2T2A-07600-007	4	16	Terminal	1	16	Terminal	4	16	Terminal
11	6SE0100-1A.21-3AA7	2T2A-07600-011	4	16	Terminal	1	16	Terminal	4	16	Terminal
15	6SE0100-1A.21-8AA7	2T2A-07600-015	4	16	Terminal	1	16	Terminal	4	16	Terminal
22	6SE0100-1A.22-5AA7	2T2A-07600-022	4	16	Terminal	1	16	Terminal	4	16	Terminal
30	6SE0100-1A.23-4AA7	2T2A-07600-030	2.5	120	1 × M8	2.5	35	Terminal	2.5	120	1 × M8
37	6SE0100-1A.24-2AA7	2T2A-07600-037	2.5	120	1 × M8	2.5	35	Terminal	2.5	120	1 × M8
45	6SE0100-1A.25-0AA7	2T2A-07600-045	2.5	120	1 × M8	2.5	35	Terminal	2.5	120	1 × M8
55	6SE0100-1A.25-8AA7	2T2A-07600-055	2.5	120	1 × M8	2.5	95	Terminal	2.5	120	1 × M8
75	6SE0100-1A.28-0AA7	2T2A-07600-075	2.5	120	1 × M8	2.5	95	Terminal	2.5	120	1 × M8
90	6SE0100-1A.31-0AA7	2T2A-07600-090	2.5	120	1 × M8	2.5	95	Terminal	2.5	120	1 × M8
110	6SE0100-1A.31-2AA7	2T2A-07600-110	2.5	120	1 × M8	2.5	95	Terminal	2.5	120	1 × M8
132	6SE0100-1A.31-4AA7	2T2A-07600-132	2.5	120	1 × M8	2.5	150	Terminal	2.5	120	1 × M8
160	6SE0100-1A.31-7AA7	2T2A-07600-160	2 × 6	2 × 240	1 × M10				2 × 6	2 × 240	1 × M10
200	6SE0100-1A.32-1AA7	2T2A-07600-200	2 × 6	2 × 240	1 × M10				2 × 6	2 × 240	1 × M10

SINAMICS G180

Configuring instructions

Cable cross-sections and connections

Overview

Type rating	Converter	Converter type	Line connection (standard)			Line connection with main switch or circuit breaker (Options: S01, S02, S03, S04, S06, S08, S09, S11, S12, S21, S22, S23, S24, S41)			Motor connection		
			Cable cross-section solid/stranded		Fixing	Cable cross-section solid/stranded		Fixing	Cable cross-section solid/stranded		Fixing
kW	SINAMICS G180		min.	max.		min.	max.		min.	max.	
			IEC	IEC		IEC	IEC		IEC	IEC	
			mm ²	mm ²		mm ²	mm ²		mm ²	mm ²	
SINAMICS G180 cabinet system 400 V 6-pulse (230 to 500 V 3 AC TN/TT system, 50 to 60 Hz)											
2.2	6SE0140-1.C15-5AA7	2X.A-8740.-002	0.5	10	Terminal	0.5	10	Terminal	0.5	10	Terminal
3	6SE0140-1.C17-0AA7	2X.A-8740.-003	0.5	10	Terminal	0.5	10	Terminal	0.5	10	Terminal
4	6SE0140-1.C21-0AA7	2X.A-8740.-004	0.5	10	Terminal	0.5	10	Terminal	0.5	10	Terminal
5.5	6SE0140-1.C21-3AA7	2X.A-8740.-005	0.5	10	Terminal	0.5	10	Terminal	0.5	10	Terminal
7.5	6SE0140-1.C21-8AA7	2X.A-8740.-007	4	16	Terminal	4	16	Terminal	4	16	Terminal
11	6SE0140-1.C21-8AA7	2X.A-8740.-011	4	16	Terminal	4	16	Terminal	4	16	Terminal
15	6SE0140-1.C23-7AA7	2X.A-8740.-015	0.75	35	Terminal	0.75	35	Terminal	0.75	35	Terminal
22	6SE0140-1.C24-8AA7	2X.A-8740.-022	0.75	35	Terminal	0.75	35	Terminal	0.75	35	Terminal
30	6SE0140-1.C25-8AA7	2X.A-8740.-030	0.75	35	Terminal	0.75	35	Terminal	0.75	35	Terminal
37	6SE0140-1.C27-8AA7	2X.A-8740.-037	2 × 6	2 × 240	1 × M10	2 × 6	2 × 240	1 × M10	2 × 6	2 × 240	1 × M10
45	6SE0140-1.C28-8AA7	2X.A-8740.-045	2 × 6	2 × 240	1 × M10	2 × 6	2 × 240	1 × M10	2 × 6	2 × 240	1 × M10
55	6SE0140-1.C31-1AA7	2X.A-8740.-055	2 × 6	2 × 240	1 × M10	2 × 6	2 × 240	1 × M10	2 × 6	2 × 240	1 × M10
75	6SE0140-1.C31-5AA7	2X.A-8740.-075	2 × 6	2 × 300	1 × M10	2 × 2.5	2 × 150	1 × M6	2 × 6	2 × 300	1 × M10
90	6SE0140-1.C31-8AA7	2X.A-8740.-090	2 × 6	2 × 300	1 × M10	2 × 6	2 × 185	1 × M10	2 × 6	2 × 300	1 × M10
110	6SE0140-1.C32-1AA7	2X.A-8740.-110	2 × 6	2 × 300	1 × M10	2 × 6	2 × 185	1 × M10	2 × 6	2 × 300	1 × M10
132	6SE0140-1.C32-5AA7	2X.A-8740.-132	2 × 6	2 × 300	1 × M10	2 × 6	2 × 185	1 × M10	2 × 6	2 × 300	1 × M10
160	6SE0140-1.C33-0AA7	2X.A-8740.-160	2 × 6	2 × 300	1 × M10	2 × 6	2 × 300	1 × M10	2 × 6	2 × 300	1 × M10
SINAMICS G180 cabinet systems 500 V 6-pulse (230 to 500 V 3 AC IT system, 50 to 60 Hz)											
2.2	6SE0140-1.D14-5AA7	2X.A-8750.-002	0.5	10	Terminal	0.5	10	Terminal	0.5	10	Terminal
3	6SE0140-1.D15-5AA7	2X.A-8750.-003	0.5	10	Terminal	0.5	10	Terminal	0.5	10	Terminal
4	6SE0140-1.D17-0AA7	2X.A-8750.-004	0.5	10	Terminal	0.5	10	Terminal	0.5	10	Terminal
5.5	6SE0140-1.D21-0AA7	2X.A-8750.-005	0.5	10	Terminal	0.5	10	Terminal	0.5	10	Terminal
7.5	6SE0140-1.D21-3AA7	2X.A-8750.-007	0.5	10	Terminal	0.5	10	Terminal	0.5	10	Terminal
11	6SE0140-1.D21-8AA7	2X.A-8750.-011	4	16	Terminal	4	16	Terminal	4	16	Terminal
15	6SE0140-1.D22-5AA7	2X.A-8750.-015	4	16	Terminal	4	16	Terminal	4	16	Terminal
22	6SE0140-1.D23-7AA7	2X.A-8750.-022	0.75	35	Terminal	0.75	35	Terminal	0.75	35	Terminal
30	6SE0140-1.D24-8AA7	2X.A-8750.-030	0.75	35	Terminal	0.75	35	Terminal	0.75	35	Terminal
37	6SE0140-1.D25-8AA7	2X.A-8750.-037	0.75	35	Terminal	0.75	35	Terminal	0.75	35	Terminal
45	6SE0140-1.D27-8AA7	2X.A-8750.-045	2 × 6	2 × 240	1 × M10	2 × 6	2 × 240	1 × M10	2 × 6	2 × 240	1 × M10
55	6SE0140-1.D28-8AA7	2X.A-8750.-055	2 × 6	2 × 240	1 × M10	2 × 6	2 × 240	1 × M10	2 × 6	2 × 240	1 × M10
75	6SE0140-1.D31-1AA7	2X.A-8750.-075	2 × 6	2 × 240	1 × M10	2 × 6	2 × 240	1 × M10	2 × 6	2 × 240	1 × M10
90	6SE0140-1.D31-5AA7	2X.A-8750.-090	2 × 6	2 × 300	1 × M10	2 × 2.5	2 × 150	1 × M6	2 × 6	2 × 300	1 × M10
110	6SE0140-1.D31-8AA7	2X.A-8750.-110	2 × 6	2 × 300	1 × M10	2 × 6	2 × 185	1 × M10	2 × 6	2 × 300	1 × M10
132	6SE0140-1.D32-1AA7	2X.A-8750.-132	2 × 6	2 × 300	1 × M10	2 × 6	2 × 185	1 × M10	2 × 6	2 × 300	1 × M10
160	6SE0140-1.D32-5AA7	2X.A-8750.-160	2 × 6	2 × 300	1 × M10	2 × 6	2 × 185	1 × M10	2 × 6	2 × 300	1 × M10
200	6SE0140-1.D33-0AA7	2X.A-8750.-200	2 × 6	2 × 300	1 × M10	2 × 6	2 × 300	1 × M10	2 × 6	2 × 300	1 × M10
SINAMICS G180 cabinet systems 690 V 6-pulse (230 to 690 V 3 AC TN/TT or IT system, 50 to 60 Hz)											
7.5	6SE0140-1..21-0AA7	2X.A-8769.-007	4	16	Terminal	4	16	Terminal	4	16	Terminal
11	6SE0140-1..21-3AA7	2X.A-8769.-011	4	16	Terminal	4	16	Terminal	4	16	Terminal
15	6SE0140-1..21-8AA7	2X.A-8769.-015	4	16	Terminal	4	16	Terminal	4	16	Terminal
22	6SE0140-1..22-5AA7	2X.A-8769.-022	4	16	Terminal	4	16	Terminal	4	16	Terminal
30	6SE0140-1..23-4AA7	2X.A-8769.-030	2 × 6	2 × 300	1 × M10	2 × 6	2 × 240	1 × M10	2 × 6	2 × 240	1 × M10
37	6SE0140-1..24-2AA7	2X.A-8769.-037	2 × 6	2 × 300	1 × M10	2 × 6	2 × 240	1 × M10	2 × 6	2 × 240	1 × M10
45	6SE0140-1..25-0AA7	2X.A-8769.-045	2 × 6	2 × 300	1 × M10	2 × 6	2 × 240	1 × M10	2 × 6	2 × 240	1 × M10
55	6SE0140-1..25-8AA7	2X.A-8769.-055	2 × 6	2 × 300	1 × M10	2 × 6	2 × 240	1 × M10	2 × 6	2 × 240	1 × M10
75	6SE0140-1..28-0AA7	2X.A-8769.-075	2 × 6	2 × 300	1 × M10	2 × 6	2 × 240	1 × M10	2 × 6	2 × 240	1 × M10
90	6SE0140-1..31-0AA7	2X.A-8769.-090	2 × 6	2 × 300	1 × M10	2 × 2.5	2 × 150	1 × M6	2 × 6	2 × 300	1 × M10
110	6SE0140-1..31-2AA7	2X.A-8769.-110	2 × 6	2 × 300	1 × M10	2 × 2.5	2 × 150	1 × M6	2 × 6	2 × 300	1 × M10
132	6SE0140-1..31-4AA7	2X.A-8769.-132	2 × 6	2 × 300	1 × M10	2 × 6	2 × 185	1 × M10	2 × 6	2 × 300	1 × M10
160	6SE0140-1..31-7AA7	2X.A-8769.-160	2 × 6	2 × 300	1 × M10	2 × 6	2 × 185	1 × M10	2 × 6	2 × 300	1 × M10
200	6SE0140-1..32-1AA7	2X.A-8769.-200	2 × 6	2 × 300	1 × M10	2 × 6	2 × 185	1 × M10	2 × 6	2 × 300	1 × M10

Overview

Type rating	Converter	Converter type	Line connection (standard)			Line connection with main switch or circuit breaker (Options: S01, S02, S03, S04, S06, S08, S09, S11, S12, S21, S22, S23, S24, S41)			Motor connection		
			Cable cross-section solid/stranded		Fixing	Cable cross-section solid/stranded		Fixing	Cable cross-section solid/stranded		Fixing
kW	SINAMICS G180		min.	max.		min.	max.		min.	max.	
			IEC	IEC		IEC	IEC		IEC	IEC	
			mm ²	mm ²		mm ²	mm ²		mm ²	mm ²	
SINAMICS G180 cabinet units 400 V 6-pulse, air-cooled (230 to 415 V 3 AC TN/TT system, 50 to 60 Hz)											
200	6SE01.0-1BA33-7AA7	2T.A-.7401-200	1 × 10 2 × 150	1 × 300 2 × 300	1 × M12	1 × 2.5 2 × 95	1 × 150 2 × 150	1 × M8	1 × 10 2 × 150	1 × 300 2 × 300	1 × M12
250	6SE01.0-1BA34-6AA7	2T.A-.7401-250	1 × 10 2 × 150	1 × 300 2 × 300	1 × M12	2 × 10	2 × 300	1 × M12	1 × 10 2 × 150	1 × 300 2 × 300	1 × M12
315	6SE01.0-1BA36-3AA7	2T.A-.7401-315	1 × 10 2 × 150	1 × 300 2 × 300	1 × M12	2 × 10	2 × 300	1 × M12	1 × 10 2 × 150	1 × 300 2 × 300	1 × M12
400	6SE01.0-1BA37-3AA7	2T.A-.7401-400	4 × 10	4 × 300	2 × M12	2 × 10 4 × 120	2 × 300 4 × 300	2 × M12	3 × 10 6 × 150	3 × 300 6 × 300	3 × M12
500	6SE01.0-1BA38-8AA7	2T.A-.7401-500	4 × 10	4 × 300	2 × M12	2 × 10 4 × 120	2 × 300 4 × 300	2 × M12	4 × 10 8 × 150	4 × 300 8 × 300	4 × M12
560	6SE01.0-1BA41-0AA7	2T.A-.7401-560	4 × 10	4 × 300	2 × M12	2 × 10 4 × 120	2 × 300 4 × 300	2 × M12	4 × 10 8 × 150	4 × 300 8 × 300	4 × M12
630	6SE01.0-1BA41-1AA7	2T.A-.7401-630	4 × 10	4 × 300	2 × M12	2 × 10 4 × 120	2 × 300 4 × 300	2 × M12	4 × 10 8 × 150	4 × 300 8 × 300	4 × M12
SINAMICS G180 cabinet units 400 V 12-pulse, air-cooled (230 to 415 V 3 AC TN/TT system, 50 to 60 Hz)											
200	6SE01.0-2BA33-7AA7	2T.F-.7401-200	1 × 10 2 × 150	1 × 300 2 × 300	1 × M12	1 × 2.5 2 × 95	1 × 150 2 × 150	1 × M8	1 × 10 2 × 150	1 × 300 2 × 300	1 × M12
250	6SE01.0-2BA34-6AA7	2T.F-.7401-250	1 × 10 2 × 150	1 × 300 2 × 300	1 × M12	2 × 10	2 × 300	1 × M12	1 × 10 2 × 150	1 × 300 2 × 300	1 × M12
315	6SE01.0-2BA36-3AA7	2T.F-.7401-315	1 × 10 2 × 150	1 × 300 2 × 300	1 × M12	2 × 10	2 × 300	1 × M12	1 × 10 2 × 150	1 × 300 2 × 300	1 × M12
400	6SE01.0-2BA37-3AA7	2T.F-.7401-400	4 × 10	4 × 300	2 × M12	2 × 10 4 × 120	2 × 300 4 × 300	2 × M12	3 × 10 6 × 150	3 × 300 6 × 300	3 × M12
500	6SE01.0-2BA38-8AA7	2T.F-.7401-500	4 × 10	4 × 300	2 × M12	2 × 10 4 × 120	2 × 300 4 × 300	2 × M12	4 × 10 8 × 150	4 × 300 8 × 300	4 × M12
560	6SE01.0-2BA41-0AA7	2T.F-.7401-560	4 × 10	4 × 300	2 × M12	2 × 10 4 × 120	2 × 300 4 × 300	2 × M12	4 × 10 8 × 150	4 × 300 8 × 300	4 × M12
630	6SE01.0-2BA41-1AA7	2T.F-.7401-630	4 × 10	4 × 300	2 × M12	2 × 10 4 × 120	2 × 300 4 × 300	2 × M12	4 × 10 8 × 150	4 × 300 8 × 300	4 × M12
SINAMICS G180 cabinet units 500 V 6-pulse, air-cooled (230 to 500 V 3 AC IT system, 50 to 60 Hz)											
250	6SE01.0-1BD33-7AA7	2T.A-.7501-250	1 × 10 2 × 150	1 × 300 2 × 300	1 × M12	1 × 2.5 2 × 95	1 × 150 2 × 150	1 × M8	1 × 10 2 × 150	1 × 300 2 × 300	1 × M12
315	6SE01.0-1BD34-6AA7	2T.A-.7501-315	1 × 10 2 × 150	1 × 300 2 × 300	1 × M12	2 × 10	2 × 300	1 × M12	1 × 10 2 × 150	1 × 300 2 × 300	1 × M12
400	6SE01.0-1BD36-3AA7	2T.A-.7501-400	1 × 10 2 × 150	1 × 300 2 × 300	1 × M12	2 × 10	2 × 300	1 × M12	1 × 10 2 × 150	1 × 300 2 × 300	1 × M12
500	6SE01.0-1BD37-3AA7	2T.A-.7501-500	4 × 10	4 × 300	2 × M12	2 × 10 4 × 120	2 × 300 4 × 300	2 × M12	3 × 10 6 × 150	3 × 300 6 × 300	3 × M12
560	6SE01.0-1BD38-2AA7	2T.A-.7501-560	4 × 10	4 × 300	2 × M12	2 × 10 4 × 120	2 × 300 4 × 300	2 × M12	4 × 10 8 × 150	4 × 300 8 × 300	4 × M12
630	6SE01.0-1BD38-8AA7	2T.A-.7501-630	4 × 10	4 × 300	2 × M12	2 × 10 4 × 120	2 × 300 4 × 300	2 × M12	4 × 10 8 × 150	4 × 300 8 × 300	4 × M12
710	6SE01.0-1BD41-0AA7	2T.A-.7501-710	4 × 10	4 × 300	2 × M12	2 × 10 4 × 120	2 × 300 4 × 300	2 × M12	4 × 10 8 × 150	4 × 300 8 × 300	4 × M12
800	6SE01.0-1BD41-1AA7	2T.A-.7501-800	4 × 10	4 × 300	2 × M12	2 × 10 4 × 120	2 × 300 4 × 300	2 × M12	4 × 10 8 × 150	4 × 300 8 × 300	4 × M12

SINAMICS G180

Configuring instructions

Cable cross-sections and connections

Overview

Type rating	Converter	Converter type	Line connection (standard)			Line connection with main switch or circuit breaker (Options: S01, S02, S03, S04, S06, S08, S09, S11, S12, S21, S22, S23, S24, S41)			Motor connection		
			Cable cross-section solid/stranded	min. IEC mm ²	max. IEC mm ²	Fixing	Cable cross-section solid/stranded	min. IEC mm ²	max. IEC mm ²	Fixing	Cable cross-section solid/stranded
SINAMICS G180 cabinet units 500 V 12-pulse, air-cooled (2 × 230 to 500 V 3 AC IT system, 50 to 60 Hz)											
250	6SE01.0-2BD33-7AA7	2T.F-.7501-250				2 × 6	2 × 185	1 × M10	1 × 10 2 × 150	1 × 300 2 × 300	1 × M12
315	6SE01.0-2BD34-6AA7	2T.F-.7501-315				2 × 6	2 × 185	1 × M10	1 × 10 2 × 150	1 × 300 2 × 300	1 × M12
400	6SE01.0-2BD36-3AA7	2T.F-.7501-400				2 × 6	2 × 300	1 × M10	1 × 10 2 × 150	1 × 300 2 × 300	1 × M12
500	6SE01.0-2BD37-3AA7	2T.F-.7501-500				2 × 6	2 × 300	1 × M10	3 × 10 6 × 150	3 × 300 6 × 300	3 × M12
560	6SE01.0-2BD38-2AA7	2T.F-.7501-560				2 × 6	2 × 300	1 × M10	4 × 10 8 × 150	4 × 300 8 × 300	4 × M12
630	6SE01.0-2BD38-8AA7	2T.F-.7501-630				2 × 6	2 × 300	1 × M10	4 × 10 8 × 150	4 × 300 8 × 300	4 × M12
710	6SE01.0-2BD41-0AA7	2T.F-.7501-710				2 × 6	2 × 300	1 × M10	4 × 10 8 × 150	4 × 300 8 × 300	4 × M12
800	6SE01.0-2BD41-1AA7	2T.F-.7501-800				2 × 6	2 × 300	1 × M10	4 × 10 8 × 150	4 × 300 8 × 300	4 × M12
SINAMICS G180 cabinet units 690 V 6-pulse, air-cooled (230 to 690 V 3 AC TN/TT or IT system, 50 to 60 Hz)											
250	6SE01.0-1B.33-2AA7	2T.A-.7601-250	2 × 10	2 × 300	1 × M12	1 × 2.5 2 × 95	1 × 150 2 × 150	1 × M8	1 × 10 2 × 150	1 × 300 2 × 300	1 × M12
315	6SE01.0-1B.33-6AA7	2T.A-.7601-315	2 × 10	2 × 300	1 × M12	1 × 2.5 2 × 95	1 × 150 2 × 150	1 × M8	1 × 10 2 × 150	1 × 300 2 × 300	1 × M12
400	6SE01.0-1B.34-2AA7	2T.A-.7601-400	2 × 10	2 × 300	1 × M12	2 × 10	2 × 300	1 × M12	1 × 10 2 × 150	1 × 300 2 × 300	1 × M12
500	6SE01.0-1B.35-2AA7	2T.A-.7601-500	2 × 10	2 × 300	1 × M12	2 × 6	2 × 300	1 × M10	3 × 10 6 × 150	3 × 300 6 × 300	3 × M12
560	6SE01.0-1B.35-7AA7	2T.A-.7601-560	4 × 10	4 × 300	2 × M12	2 × 10 4 × 120	2 × 300 4 × 300	2 × M12	4 × 10 8 × 150	4 × 300 8 × 300	4 × M12
630	6SE01.0-1B.36-4AA7	2T.A-.7601-630	4 × 10	4 × 300	2 × M12	2 × 10 4 × 120	2 × 300 4 × 300	2 × M12	4 × 10 8 × 150	4 × 300 8 × 300	4 × M12
710	6SE01.0-1B.37-1AA7	2T.A-.7601-710	4 × 10	4 × 300	2 × M12	2 × 10 4 × 120	2 × 300 4 × 300	2 × M12	4 × 10 8 × 150	4 × 300 8 × 300	4 × M12
800	6SE01.0-1B.37-7AA7	2T.A-.7601-800	4 × 10	4 × 300	2 × M12	2 × 10 4 × 120	2 × 300 4 × 300	2 × M12	4 × 10 8 × 150	4 × 300 8 × 300	4 × M12
900	6SE01.0-1B.41-0AA7	2T.A-.7601-909	4 × 10	4 × 300	2 × M12	2 × 10 4 × 120	2 × 300 4 × 300	2 × M12	4 × 10 8 × 150	4 × 300 8 × 300	4 × M12
1000	6SE01.0-1B.41-1AA7	2T.A-.7601-910	4 × 10	4 × 300	2 × M12	2 × 10 4 × 120	2 × 300 4 × 300	2 × M12	4 × 10 8 × 150	4 × 300 8 × 300	4 × M12
1200	6SE01.0-1C.41-2AA7	2T.A-.7602-912	8 × 10	8 × 300	2 × 2 × M12	2 × 10 4 × 120	2 × 300 4 × 300	2 × M12	8 × 10 16 × 150	8 × 300 16 × 300	2 × 4 × M12
1300	6SE01.0-1C.41-3AA7	2T.A-.7602-913	8 × 10	8 × 300	2 × 2 × M12	2 × 10 4 × 120	2 × 300 4 × 300	2 × M12	8 × 10 16 × 150	8 × 300 16 × 300	2 × 4 × M12
1500	6SE01.0-1C.41-5AA7	2T.A-.7602-915	8 × 10	8 × 300	2 × 2 × M12	2 × 10 4 × 120	2 × 300 4 × 300	2 × M12	8 × 10 16 × 150	8 × 300 16 × 300	2 × 4 × M12
1100	6SE01.0-1C.41-7AA7	2T.A-.7602-917	8 × 10	8 × 300	2 × 2 × M12	1) ¹⁾	1) ¹⁾	1) ¹⁾	8 × 10 16 × 150	8 × 300 16 × 300	2 × 4 × M12
1900	6SE01.0-1C.42-0AA7	2T.A-.7602-919	8 × 10	8 × 300	2 × 2 × M12	1) ¹⁾	1) ¹⁾	1) ¹⁾	8 × 10 16 × 150	8 × 300 16 × 300	2 × 4 × M12

¹⁾ On request.

Overview

Type rating	Converter	Converter type	Line connection (standard)			Line connection with main switch or circuit breaker (Options: S01, S02, S03, S04, S06, S08, S09, S11, S12, S21, S22, S23, S24, S41)			Motor connection		
			Cable cross-section solid/stranded		Fixing	Cable cross-section solid/stranded		Fixing	Cable cross-section solid/stranded		Fixing
kW			min. IEC mm ²	max. IEC mm ²		min. IEC mm ²	max. IEC mm ²		min. IEC mm ²	max. IEC mm ²	
SINAMICS G180 cabinet units 690 V 12-pulse, air-cooled (2 × 400 to 690 V 3 AC IT system, 50 to 60 Hz)											
250	6SE01.0-2BH33-2AA7	2T.F-.7601-250				2 × 2.5	2 × 150	1 × M6	1 × 10 2 × 150	1 × 300 2 × 300	1 × M12
315	6SE01.0-2BH33-6AA7	2T.F-.7601-315				2 × 6	2 × 185	1 × M10	1 × 10 2 × 150	1 × 300 2 × 300	1 × M12
400	6SE01.0-2BH34-2AA7	2T.F-.7601-400				2 × 6	2 × 185	1 × M10	1 × 10 2 × 150	1 × 300 2 × 300	1 × M12
500	6SE01.0-2BH35-2AA7	2T.F-.7601-500				2 × 6	2 × 300	1 × M10	3 × 10 6 × 150	3 × 300 6 × 300	3 × M12
560	6SE01.0-2BH35-7AA7	2T.F-.7601-560				2 × 6	2 × 300	1 × M10	4 × 10 8 × 150	4 × 300 8 × 300	4 × M12
630	6SE01.0-2BH36-4AA7	2T.F-.7601-630				2 × 6	2 × 300	1 × M10	4 × 10 8 × 150	4 × 300 8 × 300	4 × M12
710	6SE01.0-2BH37-1AA7	2T.F-.7601-710				2 × 6	2 × 300	1 × M10	4 × 10 8 × 150	4 × 300 8 × 300	4 × M12
800	6SE01.0-2BH37-7AA7	2T.F-.7601-800				2 × 6	2 × 300	1 × M10	4 × 10 8 × 150	4 × 300 8 × 300	4 × M12
900	6SE01.0-2BH41-0AA7	2T.F-.7601-909				2 × 6	2 × 300	1 × M10	4 × 10 8 × 150	4 × 300 8 × 300	4 × M12
1000	6SE01.0-2BH41-1AA7	2T.F-.7601-910				2 × 6	2 × 300	1 × M10	4 × 10 8 × 150	4 × 300 8 × 300	4 × M12
1200	6SE01.0-2CH41-2AA7	2T.F-.7602-912				2 × 10 4 × 120	2 × 300 4 × 300	2 × M12	8 × 10 16 × 150	8 × 300 16 × 300	2 × 4 × M12
1300	6SE01.0-2CH41-3AA7	2T.F-.7602-913				2 × 10 4 × 120	2 × 300 4 × 300	2 × M12	8 × 10 16 × 150	8 × 300 16 × 300	2 × 4 × M12
1500	6SE01.0-2CH41-5AA7	2T.F-.7602-915				2 × 10 4 × 120	2 × 300 4 × 300	2 × M12	8 × 10 16 × 150	8 × 300 16 × 300	2 × 4 × M12
1100	6SE01.0-2CH41-7AA7	2T.F-.7602-917				2 × 10 4 × 120	2 × 300 4 × 300	2 × M12	8 × 10 16 × 150	8 × 300 16 × 300	2 × 4 × M12
1900	6SE01.0-2CH42-0AA7	2T.F-.7602-919				2 × 10 4 × 120	2 × 300 4 × 300	2 × M12	8 × 10 16 × 150	8 × 300 16 × 300	2 × 4 × M12
2000	6SE01.0-2DH42-2AA7	2T.F-.7603-920				2 × 10 4 × 120	2 × 300 4 × 300	2 × M12	12 × 10 24 × 150	12 × 120 24 × 300	3 × 4 × M12
2300	6SE01.0-2DH42-4AA7	2T.F-.7603-923				2 × 10 4 × 120	2 × 300 4 × 300	2 × M12	12 × 10 24 × 150	12 × 120 24 × 300	3 × 4 × M12
2600	6SE01.0-2DH42-7AA7	2T.F-.7603-926				2 × 10 4 × 120	2 × 300 4 × 300	2 × M12	12 × 10 24 × 150	12 × 120 24 × 300	3 × 4 × M12
2900	6SE01.0-2DH43-0AA7	2T.F-.7603-929				2 × 10 4 × 120	2 × 300 4 × 300	2 × M12	12 × 10 24 × 150	12 × 120 24 × 300	3 × 4 × M12
3100	6SE01.0-2EH43-2AA7	2T.F-.7604-931				1) 1)	1) 1)	1)	16 × 10 32 × 150	16 × 120 32 × 300	4 × 4 × M12
3500	6SE01.0-2EH43-6AA7	2T.F-.7604-935				1) 1)	1) 1)	1)	16 × 10 32 × 150	16 × 120 32 × 300	4 × 4 × M12
3900	6SE01.0-2EH44-0AA7	2T.F-.7604-939				1) 1)	1) 1)	1)	16 × 10 32 × 150	16 × 120 32 × 300	4 × 4 × M12

1) On request.

SINAMICS G180

Configuring instructions

Cable cross-sections and connections

Overview

Type rating	Converter	Converter type	Line connection (standard)		Line connection with main switch or circuit breaker (Options: S01, S02, S03, S04, S06, S08, S09, S11, S12, S21, S22, S23, S24, S41)			Motor connection		
			Cable cross-section solid/stranded	Fixing	Cable cross-section solid/stranded	Fixing	Cable cross-section solid/stranded	Fixing		
kW			min. IEC mm ²	max. IEC mm ²	min. IEC mm ²	max. IEC mm ²		min. IEC mm ²	max. IEC mm ²	
SINAMICS G180 cabinet units 690 V 18-pulse, air-cooled (3 × 400 to 690 V 3 AC IT system, 50 to 60 Hz)										
2000	6SE01.0-3DH42-2AA7	2T.K-.7603-920			2 × 10 4 × 120	2 × 300 4 × 300	2 × M12	12 × 10 24 × 150	12 × 120 24 × 300	3 × 4 × M12
2300	6SE01.0-3DH42-4AA7	2T.K-.7603-923			2 × 10 4 × 120	2 × 300 4 × 300	2 × M12	12 × 10 24 × 150	12 × 120 24 × 300	3 × 4 × M12
2600	6SE01.0-3DH42-7AA7	2T.K-.7603-926			2 × 10 4 × 120	2 × 300 4 × 300	2 × M12	12 × 10 24 × 150	12 × 120 24 × 300	3 × 4 × M12
2900	6SE01.0-3DH43-0AA7	2T.K-.7603-929			2 × 10 4 × 120	2 × 300 4 × 300	2 × M12	12 × 10 24 × 150	12 × 120 24 × 300	3 × 4 × M12
4100	6SE01.0-3HH44-3AA7	2T.K-.7606-941			2 × 10 4 × 120	2 × 300 4 × 300	2 × M12	24 × 10 48 × 150	24 × 300 48 × 300	6 × 4 × M12
4100	6SE01.0-3HH44-8AA7	2T.K-.7606-947			1) ¹⁾	1) ¹⁾	1) ¹⁾	24 × 10 48 × 150	24 × 300 48 × 300	6 × 4 × M12
5300	6SE01.0-3HH45-4AA7	2T.K-.7606-953			1) ¹⁾	1) ¹⁾	1) ¹⁾	24 × 10 48 × 150	24 × 300 48 × 300	6 × 4 × M12
5800	6SE01.0-3HH46-0AA7	2T.K-.7606-958			1) ¹⁾	1) ¹⁾	1) ¹⁾	24 × 10 48 × 150	24 × 300 48 × 300	6 × 4 × M12
SINAMICS G180 cabinet units 690 V 24-pulse, air-cooled (4 × 400 to 690 V 3 AC IT system, 50 to 60 Hz)										
1200	6SE01.0-4CH41-2AA7	2T.L-.7602-912			2 × 6	2 × 300	1 × M10	8 × 10 16 × 150	8 × 300 16 × 300	2 × 4 × M12
1300	6SE01.0-4CH41-3AA7	2T.L-.7602-913			2 × 6	2 × 300	1 × M10	8 × 10 16 × 150	8 × 300 16 × 300	2 × 4 × M12
1500	6SE01.0-4CH41-5AA7	2T.L-.7602-915			2 × 6	2 × 300	1 × M10	8 × 10 16 × 150	8 × 300 16 × 300	2 × 4 × M12
1100	6SE01.0-4CH41-7AA7	2T.L-.7602-917			2 × 6	2 × 300	1 × M10	8 × 10 16 × 150	8 × 300 16 × 300	2 × 4 × M12
1900	6SE01.0-4CH42-0AA7	2T.L-.7602-919			2 × 6	2 × 300	1 × M10	8 × 10 16 × 150	8 × 300 16 × 300	2 × 4 × M12
3100	6SE01.0-4EH43-2AA7	2T.L-87604-931			2 × 10 4 × 120	2 × 300 4 × 300	2 × M12	16 × 10 32 × 150	16 × 120 32 × 300	4 × 4 × M12
3500	6SE01.0-4EH43-6AA7	2T.L-87604-935			2 × 10 4 × 120	2 × 300 4 × 300	2 × M12	16 × 10 32 × 150	16 × 120 32 × 300	4 × 4 × M12
3900	6SE01.0-4EH44-0AA7	2T.L-87604-939			2 × 10 4 × 120	2 × 300 4 × 300	2 × M12	16 × 10 32 × 150	16 × 120 32 × 300	4 × 4 × M12
4100	6SE01.0-4HH44-3AA7	2T.L-87606-941			2 × 10 4 × 120	2 × 300 4 × 300	2 × M12	24 × 10 48 × 150	24 × 300 48 × 300	6 × 4 × M12
4100	6SE01.0-4HH44-8AA7	2T.L-87606-947			2 × 10 4 × 120	2 × 300 4 × 300	2 × M12	24 × 10 48 × 150	24 × 300 48 × 300	6 × 4 × M12
5300	6SE01.0-4HH45-4AA7	2T.L-87606-953			2 × 10 4 × 120	2 × 300 4 × 300	2 × M12	24 × 10 48 × 150	24 × 300 48 × 300	6 × 4 × M12
5800	6SE01.0-4HH46-0AA7	2T.L-87606-958			2 × 10 4 × 120	2 × 300 4 × 300	2 × M12	24 × 10 48 × 150	24 × 300 48 × 300	6 × 4 × M12

Note:

Device cable lugs must be used to connect cables to the main switch or circuit breaker. These cable lugs are narrower, for example, than DIN cable lugs. The lugs are not normally supplied with the converter since they are generally provided by the cable installer.

It is generally possible to request a customized line connection or motor connection, see "Engineer To Order – ETO" under "Option descriptions" on Page 4/33. Please ask your Siemens contact person for further details.

¹⁾ On request.

Overview

Converter connection for different pulse numbers

Pulse number	Line connection on converter
6	Three phases
12	Two transformer secondary systems, each with three phases, i.e. six phases in total. Both systems must be phase offset by 30° in each case, e.g. using the transformer vector group Dy5d6. Important: Does not apply to 400 V units owing to the shift transformer solution – the line connection for these units is made with three phases.
18	Three transformer secondary systems, each with three phases, i.e. nine phases in total. The three systems must be phase offset by 20° in each case, e.g. using the transformer vector group Dy0y+20y-20.
24	Four transformer secondary systems, each with three phases, i.e. twelve phases in total. The four systems must be phase offset by 15° in each case, e.g. by two transformers with vector groups Dy5.25d6.25 and Dy4.75d5.75.

Required cable cross-sections for line and motor connections

In order to ensure compliance with the EMC Directive, it is generally recommended that shielded cables or cables with a concentric PE conductor of type NYCWY are used to make the cable connections from the mains supply to the converter and from the converter to the motor.

Where possible, symmetrical 3-wire three-phase power cables should be installed between the converter and the motor on drives in the higher power range. It may be necessary to connect several of these cables in parallel. There are basically two reasons for this recommendation:

- This is the only way in which the high IP55 degree of protection can be achieved for the motor terminal box without problems, because the cables enter the terminal box via glands and the number of possible glands is limited by the geometry of the terminal box. Therefore single cables are less suitable.
- With symmetrical 3-wire three-phase cables, the summed ampere-turns over the cable outer diameter are equal to zero. They can be routed in conductive, metal cable ducts or racks without any significant currents (ground currents or leakage currents) being induced in these conductive metal connections. The danger of induced leakage currents and thus of increased cable sheath losses is significantly higher with single-wire cables.

Dimensioning of connecting cable between mains supply and converter:

- The voltage load on the cable should equal at least $V_0/V = 0.6/1$ kV.
- Current load:
 - The cable cross-section must be dimensioned in accordance with the valid standards, e.g. IEC 60364-5-52.
 - The mains cable is dimensioned according to the converter input current (specified on the type plate).
- Precaution against injury due to indirect contact:
 - An overcurrent protective device with additional equipotential bonding at the motor protects against injury caused by indirect contact.
- A neutral conductor is not required.

Dimensioning of connecting cable between converter and motor:

- The voltage load on the cable should equal at least $V_0/V = 0.6/1$ kV.
- Current load:
 - The cable cross-section must be dimensioned in accordance with the valid standards, e.g. IEC 60364-5-52.
 - The motor cable is dimensioned according to the converter output current (specified on the type plate).

The required cable cross-section depends on the amperage which flows through the cable. The permissible current loading of cables is defined, for example, in IEC 60364-5-52. It depends on ambient conditions, such as temperature, but also on the routing method. An important factor to consider is whether cables are routed singly and are therefore relatively well ventilated, or whether groups of cables are routed together. In the latter instance, the cables are not ventilated so well and might therefore heat one another to a greater degree. For the relevant correction factors applicable to these boundary conditions, please refer to IEC 60364-5-52. The table below provides a guide to the recommended cross-sections (based on IEC 60364-5-52) for PVC-insulated, 3-wire copper and aluminum cables, a permissible conductor temperature of 70 °C (e.g. Protodur NYY or NYCWY) and an ambient temperature of 40 °C.

SINAMICS G180

Configuring instructions

Cable cross-sections and connections

Overview

Current-carrying capacity according to IEC 60364-5-52 at 40 °C

Cross-section 3-wire cable mm ²	3-wire copper cable		3-wire aluminum cable	
	Single routing	Groups of cables routed in parallel ¹⁾	Single routing	Groups of cables routed in parallel ¹⁾
3 × 2.5	22	17	17	13
3 × 4.0	30	23	23	18
3 × 6.0	37	29	29	22
3 × 10	52	41	40	31
3 × 16	70	54	53	41
3 × 25	88	69	68	53
3 × 35	110	86	84	65
3 × 50	133	104	102	79
3 × 70	171	133	131	102
3 × 95	207	162	159	124
3 × 120	240	187	184	144
3 × 150	278	216	213	166
3 × 185	317	247	244	190
3 × 240	374	292	287	224
3 × 300	432	337	331	259

With higher amperages, cables must be connected in parallel.

Note:

The recommendations for the North American market in AWG or MCM must be taken from the appropriate NEC (National Electrical Code) and/or CEC (Canadian Electrical Code) standards.

Grounding and PE conductor cross-section

The PE conductor must be dimensioned to meet the following requirements:

- In the case of a ground fault, no impermissibly high contact voltages resulting from voltage drops on the PE conductor caused by the ground fault current may occur (< 50 V AC or < 120 V DC, IEC 61800-5-1, IEC 60364, IEC 60543).
- The PE conductor should not be excessively loaded by any ground fault current it carries.
- If it is possible for continuous currents to flow through the PE conductor when a fault occurs, the PE conductor cross-section must be dimensioned for this continuous current.
- The PE conductor cross-section should be selected according to IEC 60204-1, IEC 60439-1, IEC 60364.

Cross-section of the phase conductor mm ²	Minimum cross-section of external PE conductor mm ²
≤ 16	Minimum phase conductor cross-section
16 ... 35	16
≥ 35	Minimum half the phase conductor cross-section

Note:

The recommendations for the North American market in AWG or MCM must be taken from the appropriate NEC (National Electrical Code) and/or CEC (Canadian Electrical Code) standards.

- Switchgear and motors are usually grounded separately via separate local ground connections. When this grounding arrangement is used, the current caused by a ground fault flows through the parallel ground connections and is divided. Despite the use of the relatively small PE conductor cross-sections specified in the table above, no impermissible contact voltages can develop with this grounding system. Based on experience with different grounding configurations, however, we recommend that the ground wire from the motor should be routed directly back to the converter. For EMC reasons and to prevent bearing currents, symmetrical 3-wire, three-phase cables should be used where possible instead of 4-wire cables, especially on drives in the higher power range. The protective or PE conductor must be routed separately when 3-wire cables are used or must be arranged symmetrically in the motor cable. The symmetry of the PE conductor is achieved using a conductor surrounding all phase conductors or using a cable with a symmetrical arrangement of the three phase conductors and three ground conductors.
- Through their high-speed controllers, the converters limit the load current (motor and ground fault currents) to an rms value corresponding to the rated current. We therefore recommend the use of a PE conductor cross-section analogous to the phase conductor cross-section for grounding the control cabinet.

¹⁾ Maximum 9 cables may be routed horizontally in direct contact with one another on a cable rack (reduction factor 0.68).

Overview

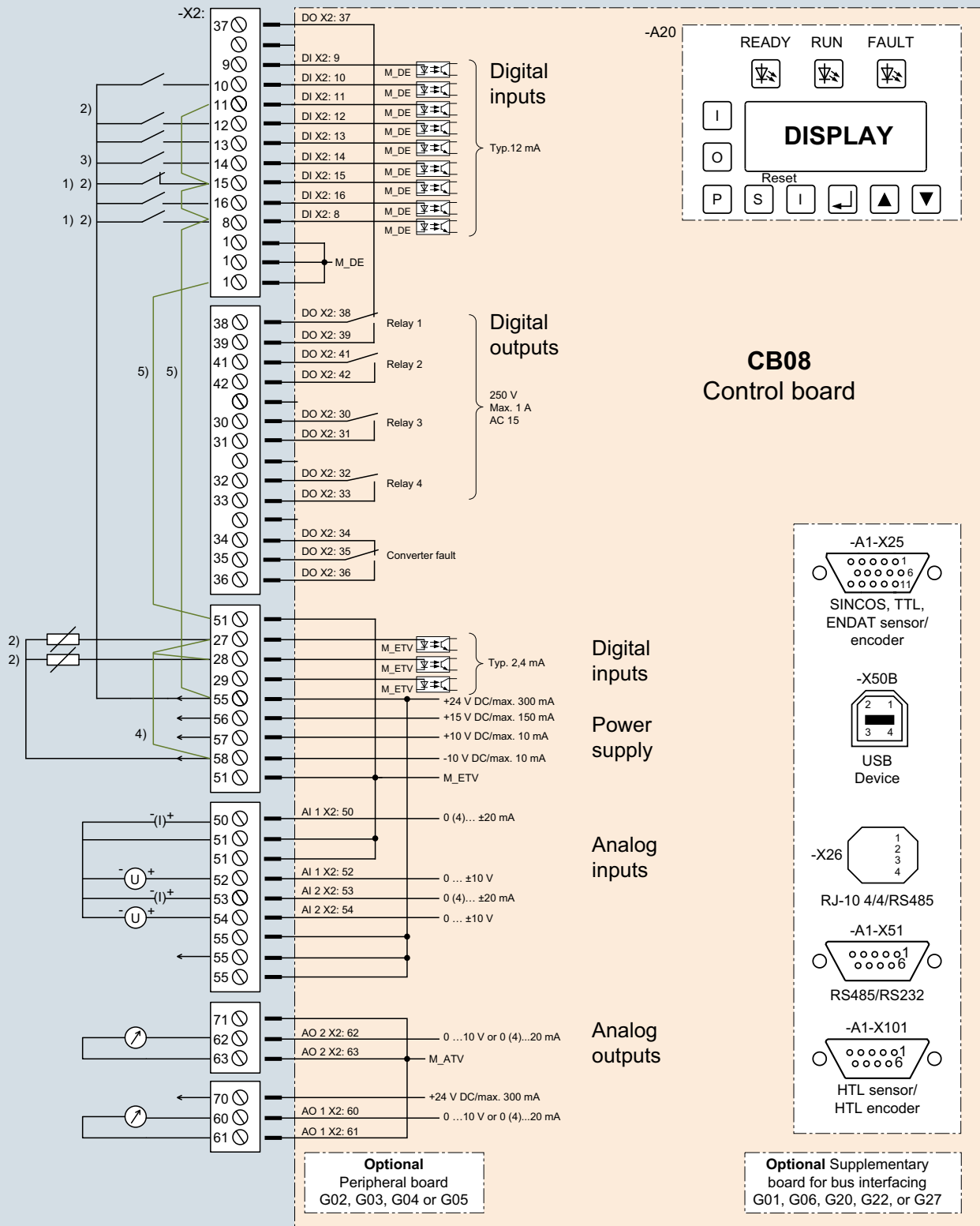

1) Global = functional for "Local" and "Remote"
 2) Remove the jumper if used.
 3) As long as "P-INTERFACES: Reset source" is set to "Global", all reset sources are always effective.

4) Max. current load of the control voltages: +24 V DC, potential 2: 300 mA
 +15 V DC, potential 2: 150 mA
 +10 V DC, potential 2: 10 mA
 -10 V DC, potential 2: 10 mA
 5) Remove both of these jumpers for peripheral board 3 / 4. Power is supplied through -X2:1/3.

G_ D024_EN_00010a

SINAMICS G180

Configuring instructions

Standard interface

Overview

Standard assignment of inputs/outputs

The following table shows the default assignments of the interface for a "standard" application.

Signal designation	Function
Digital input signals of module "CB08"	
Internal digital input 8	Controller enable global 1
Internal digital input 9	Freely parameterizable
Internal digital input 10	Speed ON remote
Internal digital input 11	Freely parameterizable
Internal digital input 12	Local/remote, remote=1
Internal digital input 13	External fault
Internal digital input 14	Remote reset
Internal digital input 15	Rapid stop global 1
Internal digital input 16	Reverse remote
Internal digital input 27	PTC thermistor trip (not for explosion-proof motors)
Internal digital input 28	PTC thermistor prewarning (not for explosion-proof motors)
Internal digital input 29	External warning
Digital output signals of module "CB08"	
Internal digital output 37, 38, 39	Relay 1: "Ready"
Internal digital output 41, 42	Relay 2: "Operation"
Internal digital output 30, 31	Relay 3: "Alarm"
Internal digital output 32, 33	Relay 4: Not assigned
Internal digital output 34, 35, 36	"Converter fault"
Analog input signals of module "CB08"	
Internal analog input 50, 51, 52	Speed setpoint
Internal analog input 53, 54	User-assignable connection
Analog output signals of module "CB08"	
Internal analog output 60, 61	Motor speed
Internal analog output 62, 63	Motor current

NAMUR-compliant assignment of inputs/outputs

The following table shows the default assignments of the interface for a "NAMUR" application.

Signal designation	Function
Digital input signals of module "CB08"	
Internal digital input 8	Main contactor checkback
Internal digital input 9	Test/Normal switch on converter
Internal digital input 10	ON/OFF static; ON dynamic (controller enable ON)
Internal digital input 11	OFF dynamic (controller enable OFF)
Internal digital input 12	Fast (motorized potentiometer UP)
Internal digital input 13	Slow (motorized potentiometer DOWN)
Internal digital input 14	Reset normal
Internal digital input 15	Interlock (controller disable)
Internal digital input 16	Reverse normal
Internal digital input 27	Freely parameterizable
Internal digital input 28	Freely parameterizable
Internal digital input 29	Freely parameterizable
Digital output signals of module "CB08"	
Internal digital output 37, 38, 39	Relay 1: "Group prewarning"
Internal digital output 41, 42	Relay 2: "Main(line)contactor closed"
Internal digital output 30, 31	Relay 3: "Ready"
Internal digital output 32, 33	Relay 4: "Motor turning"
Internal digital output 34, 35, 36	"Converter fault"
Analog input signals of module "CB08"	
Internal analog input 50, 51, 52	Speed setpoint (terminal 50/51 or 52/51)
Internal analog input 53, 54	Actual process value/user-assignable input (terminal 53/51 or 54/51)
Analog output signals of module "CB08"	
Internal analog output 60, 61	Motor speed
Internal analog output 62, 63	Motor current

Overview

Operating principle

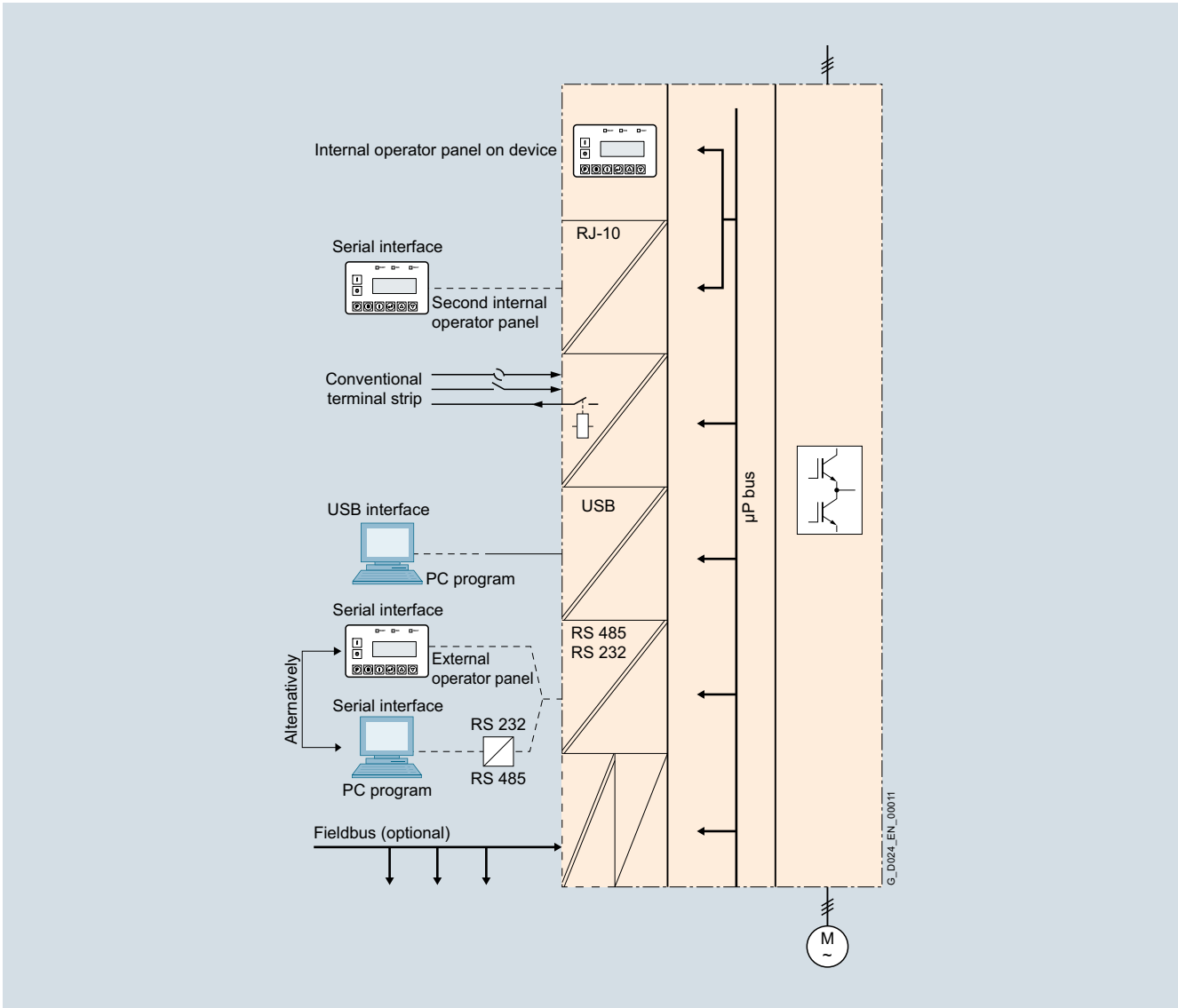

SINAMICS G180

Configuring instructions

The SINAMICS G180 type plate

Overview

SIEMENS



SINAMICS G180
FREQUENZUMRICHTER / AC DRIVE
 (1P) 6SE0100-1AC15-5AA7-Z
 L00+L72+N39



(S) N-P3155780-00002
TYPE: 2T2A-07400-002
MAT-NO: G180K

INPUT: 3AC 230-500V 5.3A 3.7kVA 47...63Hz
OUTPUT: 3AC 0-230-500V 5.5A 3.8kVA 0...250Hz

EFFICIENCY CLASS: IE2
SHORT CIRCUIT CURRENT: 60kA
DUTY CLASS: I
COOLING METHOD: AF
WEIGHT: 11.5kg
TEMPERATURE RANGE: 0...40°C
DEGREE OF PROTECTION: IP20
YEAR OF MANUFACTURE: 2022
STANDBY LOSSES: 20.6W

TC N RU Л-DE
 АИ30.В.02244

UKCA Importer UK:
 Siemens plc,
 Manchester M20 2UR

Freq.	0	0	0	50%	50%	50%	90%	90%
Current	25%	50%	100%	25%	50%	100%	50%	100%
Loss	2.0%	2.2%	2.6%	2.0%	2.3%	2.8%	2.4%	3.1%

Siemens AG, Frauenaauracher Str. 80, DE-91056 Erlangen
 Made in Germany

G_D024_XX_00063

Line	Example of type plate	Description
SINAMICS G180		Product name
(1P)	6SE0100-1AC15-5AA7-Z +L00+L72+N39	Article number of the converter Converter options
(S)	N-P3155780-00002	Serial number of the converter
TYPE	2T2A-07400-002	Type code of the converter
MAT-NO	G180K	Material number of the converter
INPUT	3 AC 230 ... 500 V 5.3 A 3.7 kVA 47 ... 63 Hz	Line-end electrical data
OUTPUT	3 AC 0 ... 230 ... 500 V 5.5 A 3.8 kVA 0 ... 250 Hz	Motor-end electrical data
EFFICIENCY CLASS	IE2	
SHORT CIRCUIT CURRENT	60 kA	Rated short-circuit current
DUTY CLASS	I	Converter duty class
COOLING METHOD	AF	Method of converter cooling AF = Air Forced WF = Water Forced AN = Air Natural (convection)
WEIGHT	11.5 kg	Converter weight
TEMPERATURE RANGE	0 ... 40 °C	Ambient temperature
DEGREE OF PROTECTION	IP20	Protection class
YEAR OF MANUFACTURE	2022	Year of manufacture
STANDBY LOSSES	20.6 W	Losses in the standby state
	Energy efficiency and power loss data in conformance with ecodesign standard IEC 61800-9-2 and ecodesign regulation (EU) 2019/1781.	
	Siemens AG Frauenaauracher Str. 80, DE-91056 Erlangen	Manufacturer's address
	Made in Germany	Country of origin

Overview

The VDEW publication ZLU (Zusätzliche Liefervereinbarungen für Umrichterantriebe in Kraftwerken (Supplementary Supply Agreements for Converter Drives in Power Plants), 1st Edition 1997) describes the design of frequency converters for power plant applications. It is noted in the preface of this document that the ZLU does not constitute a standard in the sense of a VDE regulation, but describes requirements and/or technical data and equipment details which apply additionally to converter drives used for power plant applications.

Several chapters are dedicated to describing the extensive range of equipment documentation. The KKS (Kraftwerksskennzeichnungssystem), a standardized identification system for power plants, must generally be applied throughout the documentation. As a minimum requirement, the correct KKS No. for the drive must always be stated in the documentation. The documentation must describe the converter interfaces in such a way that the destination and the type and number of used cables are clear even if these are not included in the scope of supply of the converter.

Furthermore, supplementary rules regarding documentation apply in every power plant and these must also be taken into account. These rules must generally be stated as special requirements, e.g. under "Engineer To Order – ETO" (X80), see Option descriptions on Page 4/33.

Noise emission values which might require a special design are specified in Section 1.10. Where applicable, these must be stated or selected as special requirements in options.

The ZLU also describes the converter transformer and the motor. This information must be taken into account in the design of these components.

The electrical design specifications (Chapter 4) state that the operating device must also include a key-operated switch for local control of the converter. It is further stated that the incoming supply must be connected via a fuse switch disconnecter and main contactor or via a circuit breaker. Generally speaking, requirements often deviate from this specification. The key-operated switch and the line-side power switchgear must be selected in a further option. Unless the order contains any additional information, option **S12** must be selected. This includes the local key-operated switch and the circuit breaker. Option **S02** is often selected as well.

Chapter 1.5 "Rated output" states that the drive may continuously output at least 105 %, but maximum 120 %, of the shaft power required in maximum-load operation of the driven machine. This means that the converters must always be designed with a 5 % power reserve. This must be taken into account in the drive design. Option X51 "Extended overvoltage range" does not include any power reserves, see "Engineer To Order – ETO" under Option descriptions on Page 4/33.

The device testing procedures are described in Chapter 6 "Quality assurance, Testing, Acceptance". It includes a description of routine and type tests and prescribes type tests as mandatory for first deliveries. It is not acceptable to test a selected component from a series. The operator or the ordering party or his/her representative must be given the opportunity to carry out test inspections during the manufacturing process. Furthermore, the total efficiency (transformer, converter, motor) must be verified by computation or in a test bay or at the site of installation.

Chapter 1.9 "Operational requirements" specifies special power system data in the event of load shedding of the turbine generator and offloading to auxiliary supply. The converters must remain in operation in the event of a brief frequency increase to $1.1 f_r$ for 5 s with simultaneous voltage increase to $1.25 \times V_r$ for 2 s. Depending on operational requirements, it might be necessary to agree voltage values of up to $1.4 \times V_r$. It is not possible to implement this brief overvoltage load capacity on every converter (see option description X51 Extended voltage range).

SINAMICS G180

Configuring instructions

SIZER for Siemens Drives engineering tool

Overview

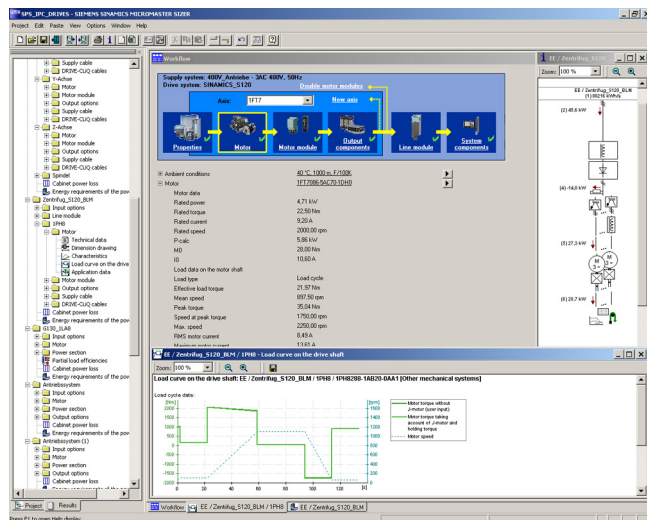

The following drives and controls can be engineered in a user-friendly way using the SIZER for Siemens Drives engineering tool:

- SIMOTICS low-voltage motors, including servo geared motors
- SIMOGEAR geared motors
- SINAMICS low-voltage drive systems
- Motor starters
- SINUMERIK CNC
- SIMOTION Motion Control controller
- SIMATIC controller

It provides support when selecting the technologies involved in the hardware and firmware components required for a drive task. SIZER for Siemens Drives covers the full range of operations required to configure a complete drive system, from basic single drives to demanding multi-axis applications.

SIZER for Siemens Drives supports all of the engineering steps in one workflow:

- Configuring the power supply
- Designing the motor and gearbox, including calculation of mechanical transmission elements
- Configuring the drive components
- Compiling the required accessories
- Selecting the line-side and motor-side power options, e.g. cables, filters, and reactors

When SIZER for Siemens Drives was being designed, particular importance was placed on a high degree of usability and a universal, function-based approach to the drive application. The extensive user guidance makes it easy to use the tool. Status information keeps you continually informed about the progress of the configuration process.

The drive configuration is saved in a project. In the project, the components and functions used are displayed in a hierarchical tree structure.

The project view permits the configuration of drive systems and the copying/inserting/modifying of drives already configured.

The configuration process produces the following results:

- A parts list of the required components (export to Excel, use of the Excel data sheet for import to SAP)
- Technical specifications of the system
- Characteristic curves
- Comments on line harmonic distortions
- Mounting arrangement of drive and control components and dimensional drawings of motors
- Energy requirements of the configured application

These results are displayed in a results tree and can be reused for documentation purposes.

Support is provided by the technological online help menu:

- Detailed technical specifications
- Information about the drive systems and their components
- Decision-making criteria for the selection of components
- Online help in English, French, German, Italian, Chinese and Japanese

System requirements

- PG or PC, with Pentium III min. 800 MHz (recommended > 1 GHz)
- 512 MB RAM (1 GB RAM recommended)
- At least 2 GB of free hard disk space
- An additional 100 MB of free hard disk space on Microsoft Windows system drive
- Screen resolution 1024 × 768 pixels
- Operating system:
 - Microsoft Windows 7 (32/64-bit) Professional, Enterprise, Ultimate, Home
 - Microsoft Windows 8.1 (32/64-bit) Professional, Enterprise, Ultimate, Home
 - Microsoft Windows 365
 - Microsoft Windows 10 (64-bit) Professional, Enterprise
- Microsoft Office 2003/2007/2010/2013/2016/365
- Microsoft Internet Explorer V8.0
- Microsoft .NET Framework 2.0
- OpenGL 2.1

Selection and ordering data

	Article number
SIZER for Siemens Drives engineering tool	6SL3070-0AA00-0AG0
DVD-ROM	
English, French, German, Italian	

More information

You can find more information on the SIZER for Siemens Drives engineering tool at:

<https://support.industry.siemens.com/cs/ww/en/ps/13434/dl>

Overview

The Siemens Product Configurator helps you to configure the optimum drive technology products for a number of applications. The product portfolio comprises the full drive technology range of gearbox, motor, converter and connection system as well as corresponding controller with suitable software license. The intuitive user interface in conjunction with product-specific preliminary selectors makes it simple, fast and efficient to configure products. The result is a bill of materials with extensive documentation consisting of technical data sheets, motor characteristic curves, 2D dimensional drawings / 3D CAD models, EPLAN macros and much more. You can order the products directly by transferring the bill of materials to the shopping cart of SiePortal.

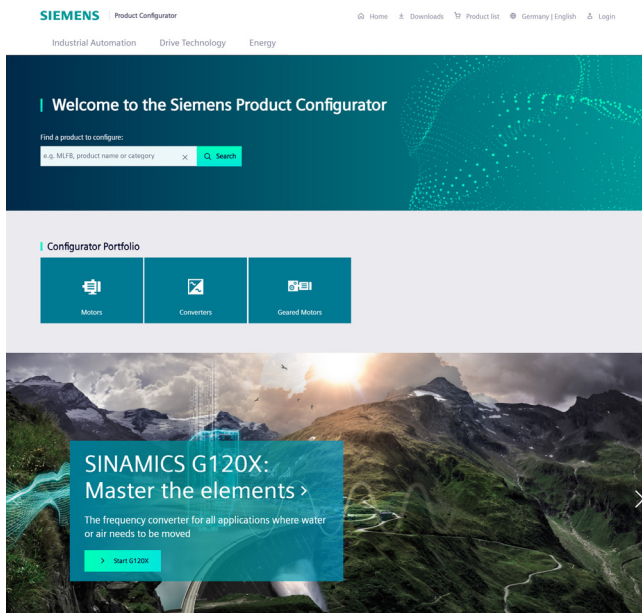

Siemens Product Configurator at a glance

- Quick and easy configuration of drive products and associated components – gearboxes, motors, converters, controllers, connection systems
- Extensive documentation for all products and components, such as
 - Data sheets in up to 12 languages
 - Motor characteristic curves
 - 2D dimensional drawings / 3D CAD models in different formats
 - Terminal box drawing and terminal connection diagram
 - Certificates
 - EPLAN macros
- Ability to order products directly through SiePortal

Access to the Siemens Product Configurator

The Siemens Product Configurator can be accessed without the need for registration or logging in:

www.siemens.com/spc

SINAMICS G180

Configuring instructions

IMS commissioning tool

Overview

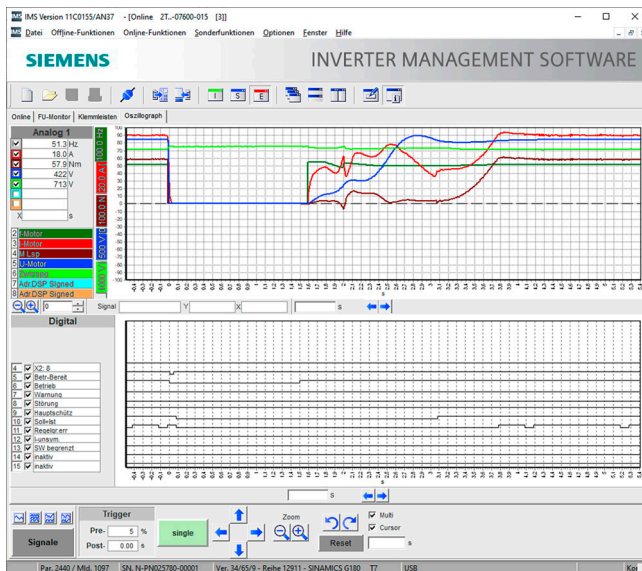
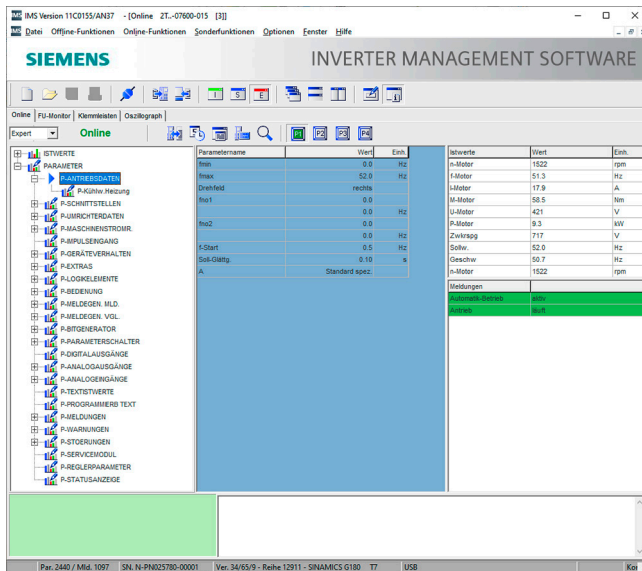

The Inverter Management Software (IMS) is the tool used to commission all versions of SINAMICS G180 drives.

This user-friendly tool is used to

- commission
- optimize and
- diagnose.

The clearly structured PC operating program supports PC-to-converter communication via USB, RS232, RS485, PROFIBUS DP or modem. A device identification function (IMS detects the firmware versions of connected drives) supports auto-adaptation to later firmware releases.

In order to ensure optimum operation and parameterization of the SINAMICS G180 converters, appropriate setting options are assigned to individual activities.

As a result, parameters are much easier to locate and the potential for making errors during commissioning, maintenance or servicing of the SINAMICS G180 converter is significantly reduced. The option of programming the unit in offline mode (no connection to the drive) facilitates local operation and reduces downtimes. The IMS also offers a comprehensive oscilloscope function which can be used for online and offline system diagnosis.

Functions

- Commissioning and operation with interactive menus
- Online/offline parameterization
- Terminal connection planning
- Convenient readout, storage and evaluation of internal status variables using the oscilloscope function
- Possibility of switching between parameter view and terminal strip view
- Function and message generators
- Extensive conversion and comparison functions
- Possibility of inserting comments for all function terminals and signals
- Management of data sets (upload, download, compare, print)
- ASCII import of all parameters for automatic generation of parameter sets
- Auto-adaptive software
- Plausibility check on parameter sets
- Detailed help texts for every parameter
- Import and export of parameter lists
- Online monitoring and condition control of converters
- Evaluation of fault messages and diagnostic information
- Available in 12 languages
- Simple firmware updates via RS232, RS485, USB, Ethernet or modem

Integration

SINAMICS G180 converters have a variety of different interfaces via which they can communicate with the Inverter Management Software or other peripheral partners (PCs, PLCs, various communication/control devices, etc.)

Apart from the standard USB interface (connection with one partner), an RS232/485 interface is also provided as standard, which permits simultaneous communication and control with several nodes. These interfaces can also be accessed by means of a modem, USB converter or Ethernet converter and therefore provide a basis for setting up a multi-Ethernet connection, for example, between up to 10 converters.

The SINAMICS G180 has also been equipped with a USB interface which can be connected directly to a PC or laptop. As an option, the SINAMICS G180 can also be supplied with a PROFIBUS interface. With this option installed, the IMS is capable of implementing "master class 1" as well as "master class 2" operation.

Selection and ordering data

	Article number
Inverter Management Software (IMS) For SINAMICS G180 as a download available free of charge on the Internet Languages: Chinese, Czech, English, French, German, Hungarian, Norwegian, Polish, Portuguese, Russian, Spanish and Swedish	See SiePortal

Accessories

	Article number
For USB interface	
USB cable (A-B), 5 m	LDX: L0330601
USB cable (A-B), 2 m	LDX: L0296421
For PROFIBUS interface	
USB cable (A-B), 2 m	LDX: L0296421
USB interface for PROFIBUS (option G13)	LDX: L0327420
Ethernet-PROFIBUS gateway (option G14)	LDX: L0327419
Power supply unit for Ethernet-PROFIBUS gateway (included with option G14 if gateway is installed in the converter cabinet)	LDX: L0176345

SINAMICS G180

Notes

5



6/2	Commissioning of SINAMICS G180
6/2	Overview
6/2	Our services
6/2	Your advantages at a glance
6/3	Maintenance and inspection of converters
6/3	Overview
6/3	Our services
6/3	Your advantages at a glance
6/4	Repairs at Headquarters
6/4	Overview
6/5	Spare parts for SINAMICS G180 converters
6/5	Overview
6/5	Spare parts packages on site
6/5	Spare parts information and database
6/5	Your advantages at a glance
6/6	Remote maintenance – Expert knowledge close at hand
6/6	Overview
6/6	Our services
6/6	Your advantages at a glance
6/7	Documentation
6/7	Overview
6/7	Installation and Operating Instructions
6/7	Certificates
6/7	For ETO converters
6/7	Converter documentation
6/8	Industry Services
6/8	Keep your business running and shaping your digital future – with Industry Services
6/9	Industry Services – portfolio overview
6/9	Digital Industry Services
6/9	Training Services
6/9	Support and Consulting Services
6/9	Spare Parts Services
6/10	Repair Services
6/10	Field and Maintenance Services
6/10	Retrofit and Modernization Services
6/10	Service Programs and Agreements
6/11	Online Support

SINAMICS G180

Services and documentation

Commissioning of SINAMICS G180

Overview



Your advantages at a glance

- High degree of flexibility and cost advantages thanks to a global network of qualified service personnel
- Direct contact between customers and manufacturer, in close collaboration with local service centers
- Short communication paths across all organizational levels
- "Global resource management" for worldwide service callouts, taking into account legal and tax-related directives
- Cross-functional drive expertise for the complete system
- Highly qualified specialists for variable-speed drives

Our services

Commissioning and on-site servicing of converters – including auxiliary equipment and built-on components for variable-speed drives up to 6 MW in the low-voltage range.

With the emphasis on the following industries

- Oil and gas
- Chemical industry
- Energy
- Shipbuilding
- Mining
- Cement
- Water and wastewater
- Auxiliaries:
 - Water cooling systems
 - Oil cooling systems
 - Higher-level control systems
 - Protective equipment
 - Static excitation units/excitation converters
 - Transformer protection

Overview



Our services

Inspection

- Recording and determining the actual condition of converters
- Comprehensive product examination based on a checklist
- Definition of additional measures required, including a report
- Service portfolio

Maintenance contracts

- Definition of the required maintenance intervals
- Remote support and availability of a technical contact person
- Agreements regarding inspection dates, spare parts, service materials and tools
- Training of the customer's service personnel

Your advantages at a glance

Inspection

- Assessment of the actual situation, measurements and diagnostics corresponding to the checklist
- Determination of the required maintenance work
- Recommendation for an optimum range of spare parts to be stocked
- Investigation of the possibilities for improving the operating conditions

Maintenance

- Maximizing the drive lifetime
- Minimizing component wear
- Avoiding non-scheduled production failures and the associated costs
- Monitoring the product life cycle and providing support on alternatives

For further information, please contact:

www.siemens.com/id-service

SINAMICS G180

Services and documentation

Repairs at Headquarters

Overview

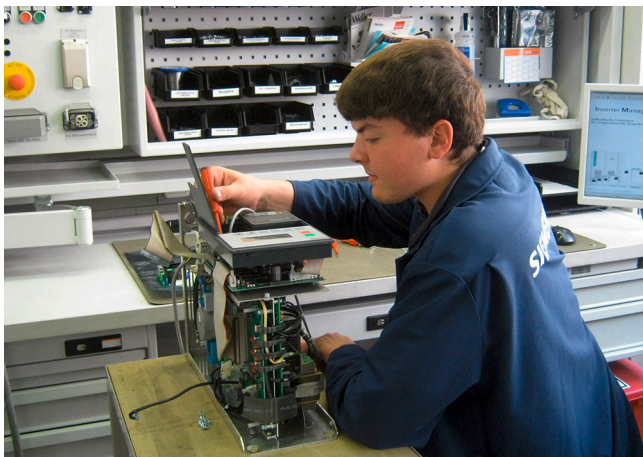

We also offer repairs and regular maintenance at our repair center. The repair and maintenance services cover all the necessary measures for restoring faulty units as well as their functionality.

Following repair, a report will be generated and a comprehensive device test will be performed. The load machines of the series test bay can be used to perform these device tests and to create the repair test report.

When equipment is returned for repair, to save time, the following information should be specified in the accompanying letter.

1. Contact partner, with fax and phone number and, if possible, email address
2. Details of the device to be repaired: type, device number, quantity, article number, date of dispatch, requested date of return, date of failure
3. Type of fault determined (e.g. fault message output, transport damage, etc.)
4. Type of processing required for repair order (e.g. supply of replacement, repair, cost estimate, inspection only)
5. Additional information about the failure (e.g. failure pattern, ambient conditions, any available measurements or oscillographs).

In urgent situations, to allow the plant to be returned to operation as quickly as possible, we also offer a fast repair service.

If required, we would be pleased to provide the customer with a repair cost estimate.

If it is determined that a repair is uneconomical, the customer will be informed and the repair will be canceled. As an alternative, a new device will be offered.

For further information, please contact:
www.siemens.com/id-service

Overview



Spare parts packages on site

For drives which often play an essential role as main drives, in addition to general service requirements, the availability of spare parts is of crucial significance.

Apart from the individual spare parts, we are also able to offer complete spare parts packages – originating from device-specific spare parts overviews. These have been generated from our extensive service experience gained through the maintenance and troubleshooting of drives and components.

Various spare part packages are available for all our devices:

- Basic Spare Package: contains the most important electronic components, e.g. for commissioning and the running-in period.
- Advanced Spare Package: contains additional electronic power components to increase the availability of the drive over the first five years in operation.

Spare parts information and database

By specifying the Siemens article number (converter type number or article number) and the corresponding serial number, you can download spare parts information for almost every current drive from a database from → **Spares On Web**:

You can view a basic list of the spare parts for your device on the Internet. All you need to enter is the Siemens article number and the associated serial number, e.g.:
6SE0100-1AH21-0AA7 & 7392665

or

the converter type and the associated serial number: e.g.:
2T2A-07600-007 & 7392665.

www.siemens.com/sow

Your advantages at a glance

- Minimization of fault-related downtimes
- In the case of a fault, no additional waiting times for spare parts to be delivered
- Increased availability of the drive unit
- Cost advantages by compiling spare part packages
- Individual package content corresponding to customer and plant requirements during the entire life cycle.

General note:

There is a necessary minimum of information that must be supplied to ensure that the correct spare part is supplied. In the order, the device number (e.g. 7370300) and the device type (e.g. 2T2A-83500-027) must generally be specified for which the spare part is required. If the spare part is intended to be stocked for several devices, it is recommended that the device types of the converters concerned are specified.



For further information, please contact:
www.siemens.com/id-service

SINAMICS G180

Services and documentation

Remote maintenance –
Expert knowledge close at hand

Overview



Our services

Complex drive systems must have a high availability and, if required, demand competent and fast support. Specialist personnel cannot always be available locally. This is the reason why we offer you the option of remotely monitoring your plants or systems.

Remote maintenance activities such as these include, for example, the following services:

- Online condition monitoring
- Data is stored so that it cannot be lost in the event of a power failure
- Trend analysis, archiving and comparison of the saved data
- If required, expert support from the local service organization
- Video-based support for plant personnel
- Definition of additional measures required, including a report

Your advantages at a glance

Remote maintenance

- Best technology on the market for high-security connections with maximum availability
- Variety of supported software applications
- Best remote maintenance platform in the industry
- Support service available around-the-clock
- Transparency through monitoring and signaling of all connections

Condition monitoring

- Minimizing non-scheduled plant downtimes and avoiding subsequent costs
- Increased plant availability
- Basis for condition-based maintenance
- Optimization and planning of service and maintenance work
- Resource-saving handling of materials as an important contribution to environmental protection
- Optimization of the spare part inventory
- Graded, versatile hardware and software concepts → scalable and flexibly adaptable to the relevant drive system

Overview

Installation and Operating Instructions

The following documentation for SINAMICS G180 compact units and ETO converters is available for download in SiePortal:

- Installation and Operating Instructions:
 - Safety instructions
 - Device overview
 - Application planning
 - Mechanical installation
 - Electrical installation
 - Commissioning
 - Operation
 - Setpoint channel and closed-loop control
 - Connecting terminals
 - Diagnostics, faults, maintenance and servicing
 - Technical data, certificates
- Inverter Management Software (IMS)
- List manual
- Display messages of the converter

Certificates

The following certificates are available for download in SiePortal:

- EC Declaration of Conformity for the Low-Voltage Directive and EMC Directive
- Declaration of incorporation according to the EC Machinery Directive
- Declaration of Conformity, STO SIL 2
- Declaration of Conformity, PTC input SIL 1
- Ex certificate for PTC evaluation to ATEX (prototype test certificate)

For ETO converters

The converter documentation will be supplied by email in PDF format (English/German) as preliminary documentation 6 or 7 weeks after order clarification.

The final documentation for configured converters will normally be sent by email in PDF format (English/German) 1 or 2 weeks after dispatching the converter.

A different document format can be ordered if required (see Option descriptions).

Note:

Please contact your Siemens partner in the sales office if you require documentation in a different language.

Converter documentation

- Set of diagrams, as follows:
 - Cover sheet and table of contents of converter documentation (customer, project number, article number, serial number, type)
 - Technical data of the equipment, type data
 - Installation diagrams (dimension sheet, cross-sectional view, labels, equipment type plate, internal view, mounting plate)
 - Terminal diagrams (line connection, CB08 control plate, peripheral board, converter output, motor connection, internal terminals, controller)
 - Circuit diagram (infeed (where applicable, also with transformer), converter, motor, control voltage, digital inputs and outputs, analog inputs and outputs, D-sub connections, I/Os and any other options, such as a local control box)
 - Parts list
- Acceptance test certificate (PDF format)
- List of parameters, set according to customer requirements (PDF format, single language)

Optionally available:

- Acceptance report enclosed with the acceptance option **F71**

SINAMICS G180

Services and documentation

Industry Services

Overview

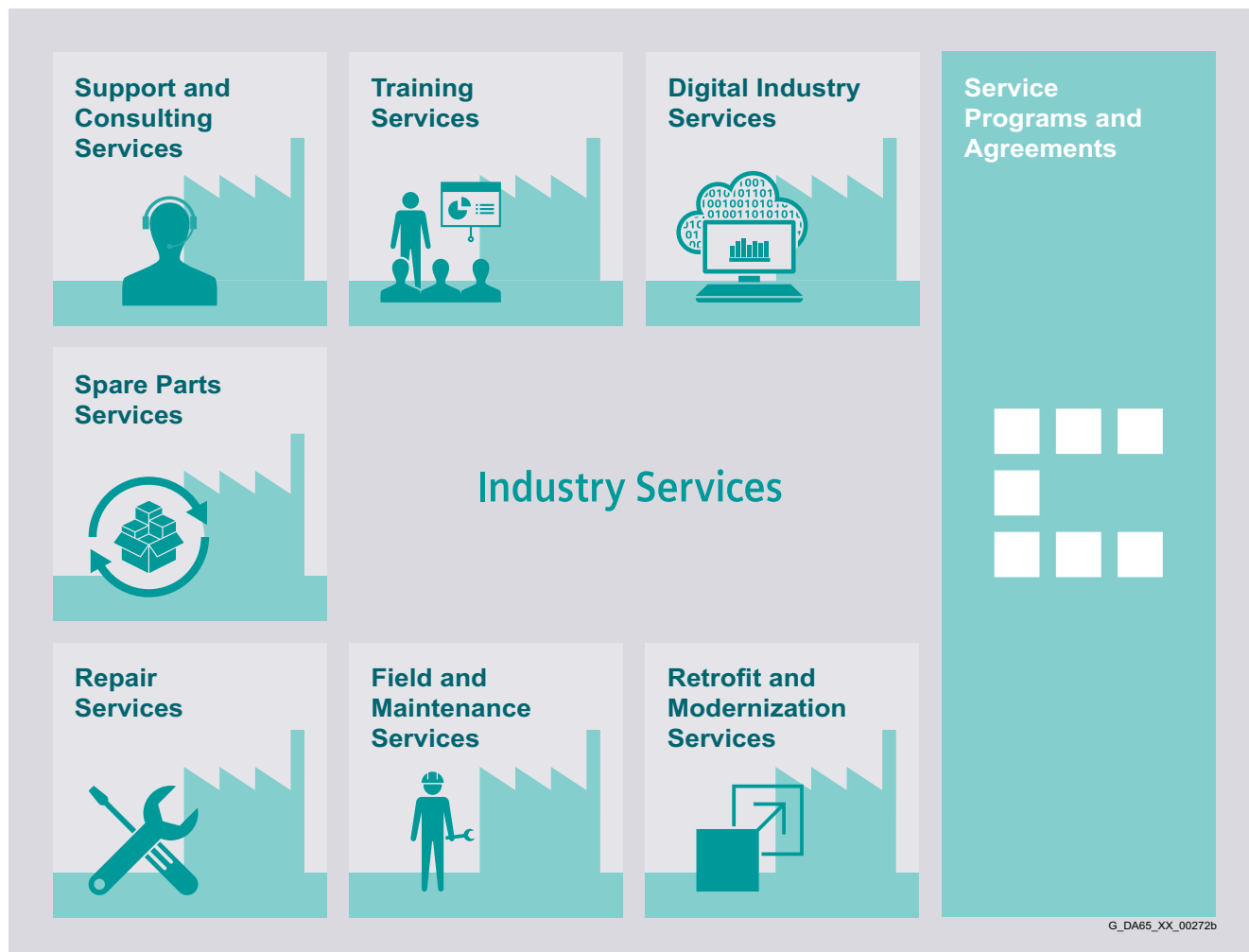

Keep your business running and shaping your digital future – with Industry Services

Optimizing the productivity of your equipment and operations can be a challenge, especially with constantly changing market conditions. Working with our service experts makes it easier. We understand your industry's unique processes and provide the services needed so that you can better achieve your business goals.

You can count on us to maximize your uptime and minimize your downtime, increasing your operations' productivity and reliability. When your operations have to be changed quickly to meet a new demand or business opportunity, our services give you the flexibility to adapt. Of course, we take care that your production is protected against cyber threats. We assist in keeping your operations as energy and resource efficient as possible and reducing your total cost of ownership. As a trendsetter, we ensure that you can capitalize on the opportunities of digitalization and by applying data analytics to enhance decision making: You can be sure that your plant reaches its full potential and retains this over the longer lifespan.

You can rely on our highly dedicated team of engineers, technicians and specialists to deliver the services you need – safely, professionally and in compliance with all regulations. We are there for you, where you need us, when you need us.

www.siemens.com/industrieservices

Overview

Digital Industry Services



Digital Industry Services make your industrial processes transparent to gain improvements in productivity, asset availability, and energy efficiency.

Production data is generated, filtered and translated with intelligent analytics to enhance decision-making.

This is done whilst taking data security into consideration and with continuous protection against cyber-attack threats.

www.siemens.com/global/en/products/services/industry/digital-industry-services.html

Training Services



From the basics and advanced to specialist skills, SITRAIN courses provide expertise right from the manufacturer – and encompass the entire spectrum of Siemens products and systems for the industry.

Worldwide, SITRAIN courses are available wherever you need a training course in more than 170 locations in over 60 countries.

<https://support.industry.siemens.com/cs/ww/en/sc/2226>

Support and Consulting Services



Industry Online Support site for comprehensive information, application examples, FAQs and support requests.

Technical and Engineering Support for advice and answers for all inquiries about functionality, handling, and fault clearance. The Service Card as prepaid support for value added services such as Priority Call Back or Extended Support offers the clear advantage of quick and easy purchasing.

Information & Consulting Services, e.g. SIMATIC System Audit; clarity about the state and service capability of your automation system or Lifecycle Information Services; transparency on the lifecycle of the products in your plants.

<https://support.industry.siemens.com/cs/ww/en/sc/2235>

Spare Parts Services



Spare Parts Services are available worldwide for smooth and fast supply of spare parts – and thus optimal plant availability. Genuine spare parts are available for up to ten years. Logistic experts take care of procurement, transport, custom clearance, storage and order management. Reliable logistics processes ensure that components reach their destination as needed.

Since not all spare parts can be kept in stock at all times, Siemens offers a preventive measure for spare parts provisioning on the customer's premises with optimized **Spare Parts Packages** for individual products, custom-assembled drive components and entire integrated drive trains – including risk consulting.

Asset Optimization Services help you design a strategy for parts supply where your investment and carrying costs are reduced and the risk of obsolescence is avoided.

<https://support.industry.siemens.com/cs/ww/en/sc/2110>

SINAMICS G180

Services and documentation

Industry Services – Portfolio overview

Overview (continued)

Repair Services



Repair Services are offered on-site and in regional repair centers for fast restoration of faulty devices' functionality.

Also available are extended repair services, which include additional diagnostic and repair measures, as well as emergency services.

<https://support.industry.siemens.com/cs/ww/en/sc/2154>

Retrofit and Modernization Services



Provide a cost-effective solution for the expansion of entire plants, optimization of systems or upgrading existing products to the latest technology and software, e.g. migration services for automation systems.

Service experts support projects from planning through commissioning and, if desired over the entire extended lifespan, e.g. Retrofit for Integrated Drive Systems for an extended lifetime of your machines and plants.

<https://support.industry.siemens.com/cs/ww/en/sc/2286>

Field and Maintenance Services

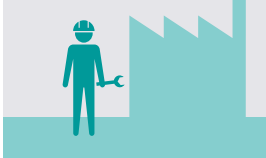

Siemens specialists are available globally to provide expert field and maintenance services, including commissioning, functional testing, preventive maintenance and fault clearance.

All services can be included in customized service agreements with defined reaction times or fixed maintenance intervals.

<https://support.industry.siemens.com/cs/ww/en/sc/2265>

Service Programs and Agreements



A technical Service Program or Agreement enables you to easily bundle a wide range of services into a single annual or multi-year agreement.

You pick the services you need to match your unique requirements or fill gaps in your organization's maintenance capabilities.

Programs and agreements can be customized as KPI-based and/or performance-based contracts.

<https://support.industry.siemens.com/cs/ww/en/sc/2275>

Overview

Online Support – fast, intuitive, whenever you want, wherever you need

Web

www.siemens.com/online-support

App

Scan the QR code for information on our Online Support app.

- FAQ / Application examples**
Information about industrial products, programming and configuration as well as application examples
- Technical information**
Videos, documentation, manuals, updates, product notes, compatibility tool, certificates, planning data such as dimensional drawings, product data, 3D models
- Forum**
Exchange information and experience with other users and experts

Online Support for Siemens Industry Products

Siemens Industry and Online Support with some 1.7 million visitors per month is one of the most popular web services provided by Siemens. It is the central access point for comprehensive technical know-how about products, systems and services for automation and drives applications as well as for process industries.

In connection with the challenges and opportunities related to digitalization you can look forward to continued support with innovative offerings.

SINAMICS G180

Notes

6

Appendix



7/2	Partners at Siemens
7/3	Online Services
7/3	<u>Information and Ordering in the Internet</u>
7/3	Siemens Industry Automation and Drive Technologies in the WWW
7/3	Easy Shopping with the Industry Mall
7/4	<u>Social Media, Mobile Media</u>

7/13	Conditions of sale and delivery
-------------	--

Partners at Siemens

SIEMENS Competence Spare parts / Repairs / Call... Products All Products and Branches Region All Regions Contact Global | English

Contacts at Siemens

Please choose a city in the upper search field, if possible. Or select a city or a contact person on the map on the right. If you do not find your city in the selection, we recommend choosing the nearest city.

Siemens Nv/SA

Digital Factory - Process Industries and Drives - Service Shop

Address: GUIDO GEZELLESTRAAT 123, 1654 Beersel, Belgium

Communication data: +32 2 536 4971, +32 2 536 6851, id@repairs.be@siemens.com, http://www.siemens.be/inductie

Competences: Spare parts / Repairs... (1) Products & Branches: Pause Filter (1) Region: Pause Filter (1)

Siemens SPA

Digital Factory - Process Industries and Drives - Service

Address: Lotissement el Kadous, Lot No 10, 16035 Algier, Algeria

Communication data: +213 21 36 14 55587475768294, +213 770 17 29 82, +213 21 36 13 79, support_automation_id@siemens.com, sahab_benamer@siemens.com, http://www.siemens.com

Competences: Spare parts / Repairs... (1) Products & Branches: Pause Filter (1) Region: Pause Filter (1)

At your service locally, around the globe for consulting, sales, training, service, support, spare parts ... on the entire portfolio of Siemens.

Your partner can be found in our Personal Contacts Database at: www.siemens.com/automation-contact

You start by selecting a

- the required competence,
- products and branches,
- a country and a city

or by a

- location search or free text search.

Siemens Industry Automation and Drive Technologies in the WWW

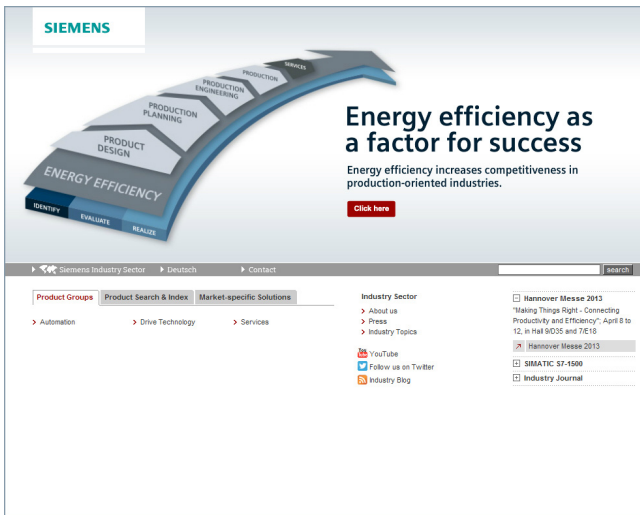

A detailed knowledge of the range of products and services available is essential when planning and configuring automation systems. It goes without saying that this information must always be fully up-to-date.

Siemens Industry Automation and Drive Technologies has therefore built up a comprehensive range of information in the World Wide Web, which offers quick and easy access to all data required.

Under the address

www.siemens.com/industry

you will find everything you need to know about products, systems and services.

Easy Shopping with the Industry Mall

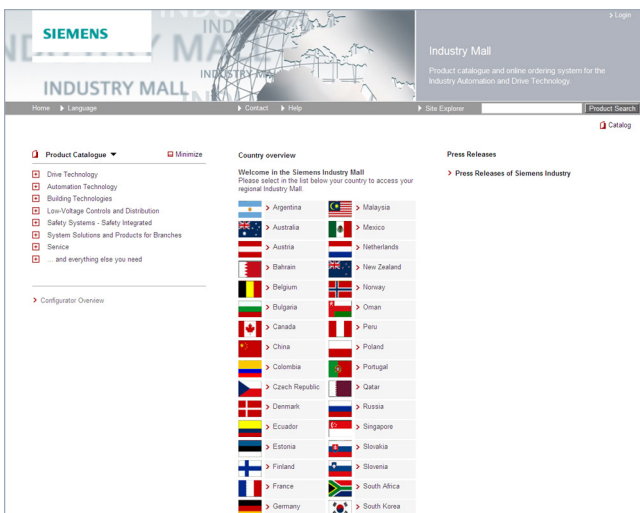

The Industry Mall is the virtual department store of Siemens AG on the Internet. Here you have access to a huge range of products presented in electronic catalogs in an informative and attractive way.

Data transfer via EDIFACT allows the whole procedure from selection through ordering to tracking of the order to be carried out online via the Internet.

Numerous functions are available to support you.

For example, powerful search functions make it easy to find the required products, which can be immediately checked for availability. Customer-specific discounts and preparation of quotes can be carried out online as well as order tracking and tracing.

Please visit the Industry Mall on the Internet under:

www.siemens.com/industrymall

SINAMICS G180

Appendix

Online Services – Social Media, Mobile Media

Social Media

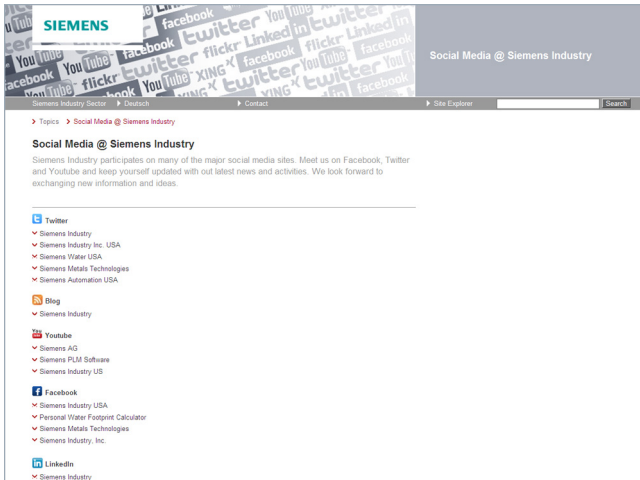

Connect with Siemens through social media: visit our social networking sites for a wealth of useful information, demos on products and services, the opportunity to provide feedback, to exchange information and ideas with customers and other Siemens employees, and much, much more. Stay in the know and follow us on the ever-expanding global network of social media.

Connect with Siemens Industry at our central access point:

www.siemens.com/industry/socialmedia

Or via our product pages at:

www.siemens.com/automation

or

www.siemens.com/drives

To find out more about Siemens' current social media activities visit us at:

www.siemens.com/socialmedia

Mobile Media

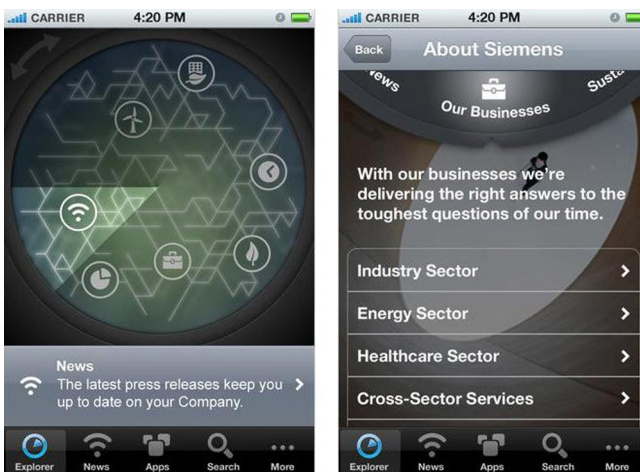

Discover the world of Siemens.

We are also constantly expanding our offering of cross-platform apps for smartphones and tablets. You will find the current Siemens apps at the app store (iOS) or at Google Play (Android).

The Siemens app, for example, tells you all about the history, latest developments and future plans of the company – with informative pictures, fascinating reports and the most recent press releases.

1. General Provisions

By using this catalog you can purchase products (hardware, software and services) described therein from Siemens Aktiengesellschaft subject to the following Terms and Conditions of Sale and Delivery (hereinafter referred to as "T&C"). Please note that the scope, the quality and the conditions for supplies and services, including software products, by any Siemens entity having a registered office outside Germany, shall be subject exclusively to the General Terms and Conditions of the respective Siemens entity. The following T&C apply exclusively for orders placed with Siemens Aktiengesellschaft, Germany.

1.1 For customers with a seat or registered office in European Union

For customers with a seat or registered office in European Union, the following terms and conditions apply subordinate to T&C:

- for products, which include specific terms and conditions in the description text, these specific terms and conditions shall apply and subordinate thereto,
- for stand-alone software products and software products forming a part of a product or project, the "General License Conditions for Software Products for Automation and Drives for Customers with a Seat or registered Office in Germany"¹⁾ and/or
- for consulting services the "Allgemeine Geschäftsbedingungen für Beratungsleistungen der Division DF – Deutschland" (available only in German) and/or
- for other services, the „Supplementary Terms and Conditions for Services ("BL")"¹⁾ and/or
- for other supplies the "General Conditions for the Supply of Products and Services of the Electrical and Electronics Industry"¹⁾.

In case such supplies should contain Open Source Software, the conditions of which shall prevail over the "General Conditions for the Supply of Products and Services of the Electrical and Electronics Industry"¹⁾, a notice will be contained in the scope of delivery in which the applicable conditions for Open Source Software are specified. This shall apply mutatis mutandis for notices referring to other third party software components.

1.2 For customers with a seat or registered office outside European Union

For customers with a seat or registered office outside European Union, the following terms and conditions apply subordinate to T&C:

- for products, which include specific terms and conditions in the description text, these specific terms and conditions shall apply and subordinate thereto,
- for consulting services the "Standard Terms and Conditions for Consulting Services of the Division DF for Customers with a Seat or Registered Office Outside of Germany"¹⁾ and/or
- for other services the "International Terms & Conditions for Services"¹⁾ supplemented by "Software Licensing Conditions"¹⁾ and/or
- for other supplies of hard- and software the "International Terms & Conditions for Products"¹⁾ supplemented by "Software Licensing Conditions"¹⁾

1.3 For customers with master or framework agreement

To the extent our supplies and/or services offered are covered by an existing master or framework agreement, the terms and conditions of that agreement shall apply instead of T&C.

2. Prices

The prices are in € (Euro) ex point of delivery, exclusive of packaging.

The sales tax (value added tax) is not included in the prices. It shall be charged separately at the respective rate according to the applicable statutory legal regulations.

Prices are subject to change without prior notice. We will charge the prices valid at the time of delivery.

To compensate for variations in the price of raw materials (e.g. silver, copper, aluminum, lead, gold, dysprosium and neodym), surcharges are calculated on a daily basis using the so-called metal factor for products containing these raw materials.

A surcharge for the respective raw material is calculated as a supplement to the price of a product if the basic official price of the raw material in question is exceeded.

The metal factor of a product indicates the basic official price (for those raw materials concerned) as of which the surcharges on the price of the product are applied, and with what method of calculation.

An exact explanation of the metal factor can be downloaded at:

https://mall.industry.siemens.com/legal/ww/en/terms_of_trade_en.pdf

To calculate the surcharge (except in the cases of dysprosium and neodym), the official price from the day prior to that on which the order was received or the release order was effected is used.

To calculate the surcharge applicable to dysprosium and neodym ("rare earths"), the corresponding three-month basic average price in the quarter prior to that in which the order was received or the release order was effected is used with a one-month buffer (details on the calculation can be found in the explanation of the metal factor).

3. Additional Terms and Conditions

The dimensions are in mm. In Germany, according to the German law on units in measuring technology, data in inches apply only to devices for export.

Illustrations are not binding.

Insofar as there are no remarks on the individual pages of this catalog – especially with regard to data, dimensions and weights given – these are subject to change without prior notice.

¹⁾ The text of the Terms and Conditions of Siemens AG can be downloaded at
https://mall.industry.siemens.com/legal/ww/en/terms_of_trade_en.pdf

4. Export Regulations

We shall not be obligated to fulfill any agreement if such fulfillment is prevented by any impediments arising out of national or international foreign trade or customs requirements or any embargoes and/or other sanctions.

Export may be subject to license. We shall indicate in the delivery details whether licenses are required under German, European and US export lists.

Our products are controlled by the U.S. Government (when labeled with "ECCN" unequal "N") and authorized for export only to the country of ultimate destination for use by the ultimate consignee or end-user(s) herein identified. They may not be resold, transferred, or otherwise disposed of, to any other country or to any person other than the authorized ultimate consignee or end-user(s), either in their original form or after being incorporated into other items, without first obtaining approval from the U.S. Government or as otherwise authorized by U.S. law and regulations. Products labeled with "AL" unequal "N" are subject to European / national export authorization.

The export indications can be viewed in advance in the description of the respective goods on the Industry Mall, our online catalog system. Only the export labels "AL" and "ECCN" indicated on order confirmations, delivery notes and invoices are authoritative.

Products without label, with label "AL:N" / "ECCN:N", or label "AL:9X9999" / "ECCN: 9X9999" may require authorization from responsible authorities depending on the final end-use, or the destination.

If you transfer goods (hardware and/or software and/or technology as well as corresponding documentation, regardless of the mode of provision) delivered by us or works and services (including all kinds of technical support) performed by us to a third party worldwide, you shall comply with all applicable national and international (re-)export control regulations. In any event of such transfer of goods, works and services you shall comply with the (re-) export control regulations of the Federal Republic of Germany, of the European Union and of the United States of America.

Prior to any transfer of goods, works and services provided by us to a third party you shall in particular check and guarantee by appropriate measures that

- there will be no infringement of an embargo imposed by the European Union, by the United States of America and/ or by the United Nations by such transfer, by brokering of contracts concerning those goods, works and services or by provision of other economic resources in connection with those goods, works and services, also considering the limitations of domestic business and prohibitions of by-passing those embargoes;
- such goods, works and services are not intended for use in connection with armaments, nuclear technology or weapons, if and to the extent such use is subject to prohibition or authorization, unless required authorization is provided;
- the regulations of all applicable Sanctioned Party Lists of the European Union and the United States of America concerning the trading with entities, persons and organizations listed therein are considered.

If required to enable authorities or us to conduct export control checks, you, upon request by us, shall promptly provide us with all information pertaining to the particular end customer, the particular destination and the particular intended use of goods, works and services provided by us, as well as any export control restrictions existing.

You acknowledge that under the EU embargo regulations against Iran, Syria and Russia respectively the sale of certain listed goods and related services is subject to authorization by the competent export control authorities of the European Union. If (i) the goods or services ordered by you are destined for Iran, Syria or Russia, and (ii) the contract for our supplies and/or services is subject to prior authorization of the competent export control authorities of the European Union, the contract between you and us shall come into force in this respect only upon granting of such authorization.

The products listed in this catalog may be subject to European/German and/or US export regulations. Any export requiring approval is therefore subject to authorization by the relevant authorities.

Errors excepted and subject to change without prior notice.

Selection and ordering at Siemens

SiePortal – Ordering products and downloading catalogs

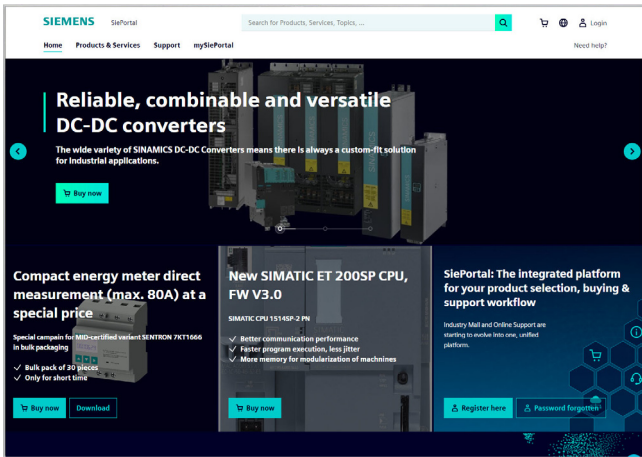

Easy product selection and ordering with SiePortal

SiePortal > Products & Services

The internet ordering platform of Siemens AG is located in SiePortal. It provides you with online access to a comprehensive product spectrum that is presented in an informative, well-organized way.

Powerful search functions help you select the required products, while configurators enable you to configure complex product and system components quickly and easily. CAX data are also available for you to use.

Data transfer allows the entire procedure, from selection through ordering to tracking and tracing, to be carried out online. Availability checks, individual customer discounting, and quotation preparation are also possible.

<https://sieportal.siemens.com>

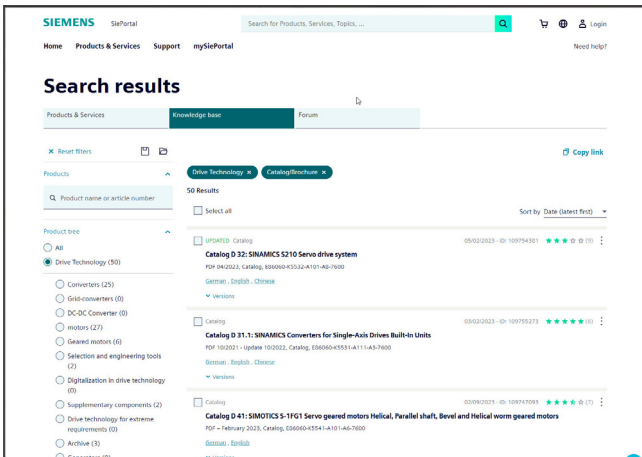

Downloading catalogs

SiePortal > Support > Knowledge base

You can download catalogs and brochures in PDF format from Siemens Industry Online Support without having to register.

The filter box makes it possible to perform targeted searches.

<https://sieportal.siemens.com>

Get more information

The SINAMICS converter family:
www.siemens.com/sinamics

SINAMICS G180
Converters – Compact Units, Cabinet Systems,
Cabinet Units Air-Cooled:
www.siemens.com/sinamics-g180

Local partners worldwide:
www.siemens.com/automation-contact

Published by
Siemens AG

Digital Industries
Motion Control
Postfach 31 80
91050 Erlangen, Germany

(Article No. E86060-K5518-A111-A3-7600)
V6.MKKATA.GMC.520
KG 0923 192 En
Produced in Germany
© Siemens AG 2023

Subject to changes and errors. The information given in this document only contains general descriptions and/or performance features which may not always specifically reflect those described, or which may undergo modification in the course of further development of the products. The requested performance features are binding only when they are expressly agreed upon in the concluded contract.

All product designations may be trademarks or product names of Siemens AG or other companies whose use by third parties for their own purposes could violate the rights of the owners.

www.siemens.com/drives