



Edition

07/2023

INSTALLATION AND OPERATING INSTRUCTIONS

SINAMICS

SINAMICS G180

Converters – Compact Units, Cabinet Systems,
Cabinet Units Air-Cooled and Liquid-Cooled

SIEMENS

SINAMICS

Installation and Operating Instructions SINAMICS G180

Operating Instructions

<u>Introduction</u>	1
<u>Safety information</u>	2
<u>Description</u>	3
<u>Preparations for use</u>	4
<u>Installation</u>	5
<u>Electrical connection</u>	6
<u>Commissioning</u>	7
<u>Operation</u>	8
<u>Maintenance</u>	9
<u>Spare parts</u>	10
<u>Diagnostics, faults and warnings</u>	11
<u>Service & Support</u>	A
<u>Quality documents</u>	B
<u>Technical data</u>	C
<u>List of abbreviations</u>	D

Translation of the original instructions



07/2023

4BS0751-011

Legal information

Warning notice system

This manual contains notices you have to observe in order to ensure your personal safety, as well as to prevent damage to property. The notices referring to your personal safety are highlighted in the manual by a safety alert symbol, notices referring only to property damage have no safety alert symbol. These notices shown below are graded according to the degree of danger.

 DANGER
indicates that death or severe personal injury will result if proper precautions are not taken.
 WARNING
indicates that death or severe personal injury may result if proper precautions are not taken.
 CAUTION
indicates that minor personal injury can result if proper precautions are not taken.
NOTICE
indicates that property damage can result if proper precautions are not taken.

If more than one degree of danger is present, the warning notice representing the highest degree of danger will be used. A notice warning of injury to persons with a safety alert symbol may also include a warning relating to property damage.

Qualified Personnel

The product/system described in this documentation may be operated only by **personnel qualified** for the specific task in accordance with the relevant documentation, in particular its warning notices and safety instructions. Qualified personnel are those who, based on their training and experience, are capable of identifying risks and avoiding potential hazards when working with these products/systems.

Proper use of Siemens products

Note the following:

 WARNING
Siemens products may only be used for the applications described in the catalog and in the relevant technical documentation. If products and components from other manufacturers are used, these must be recommended or approved by Siemens. Proper transport, storage, installation, assembly, commissioning, operation and maintenance are required to ensure that the products operate safely and without any problems. The permissible ambient conditions must be complied with. The information in the relevant documentation must be observed.

Trademarks

All names identified by ® are registered trademarks of Siemens AG. The remaining trademarks in this publication may be trademarks whose use by third parties for their own purposes could violate the rights of the owner.

Disclaimer of Liability

We have reviewed the contents of this publication to ensure consistency with the hardware and software described. Since variance cannot be precluded entirely, we cannot guarantee full consistency. However, the information in this publication is reviewed regularly and any necessary corrections are included in subsequent editions.

Table of contents

1	Introduction	9
1.1	About these instructions	9
1.2	Intended use	9
1.3	Validity	10
1.4	Text format features	10
1.5	Presentation of the display buttons in the operating instructions	11
1.6	Specific features	12
2	Safety information	13
2.1	The five safety rules	13
2.2	Use of tested, certified and Siemens-approved components	14
2.3	Areas that are potentially and particularly hazardous	15
2.4	Notes for operator protection.....	16
2.5	Notes on liquid cooling	19
2.6	Safety precautions when handling anti-freeze	20
2.7	Standards and guidelines for proper use of inverters	21
2.8	Plant safety.....	22
2.9	Security information	23
2.10	Components that can be destroyed by electrostatic discharge (ESD)	24
2.11	Electromagnetic fields.....	26
2.12	Radio telephones and mobile telephones	27
2.13	Note regarding fiber-optic cables	28
2.14	Protecting/fusing the external 230 V AC control voltage	28
2.15	Residual risks of power drive systems	29
3	Description	31
3.1	Updating inverter software or instructions.....	31
3.2	Order numbers MLFB / Type designations	31
3.3	Accessories	36
3.3.1	Use of tested, certified and Siemens-approved components	36
3.3.2	Peripheral boards 1 to 4, -A95, option G02 to G05.....	37
3.3.2.1	General information about the peripheral boards 1 to 4	37
3.3.2.2	Electronic shutdown for "Safe halt" / PTC inputs.....	38
3.3.2.3	Z options with "Safe Torque Off" or ATEX shutdown	42
3.3.2.4	"Safe torque off" with single circuit trip	42

3.3.2.5	"Safe torque off" with two circuit version.....	43
3.3.2.6	Switchover, single circuit <-> two circuit tripping	43
3.3.2.7	Checking the "Safe halt" function	45
3.3.2.8	PTC inputs for motor PTC thermistor.....	47
3.3.3	Brake transistor and brake resistor	49
3.3.3.1	Dimensioning the brake resistor.....	49
3.3.3.2	Connecting the brake resistor	49
3.3.4	Parameter overview.....	50
3.3.5	"Factory settings" application	50
3.3.6	Protective cover IP21 for compact and compact Plus devices	51
3.3.7	Main switch "Q 2T..." or "W 2T...".....	52
3.3.8	DC link terminals for compact devices	52
3.3.9	External display	54
3.3.10	RFI suppression filter, category C1 (class B)	55
3.3.11	Strengthened du/dt filter	55
3.3.12	Sine-wave filter.....	55
3.3.13	Additional mains power protection chokes	55
3.3.14	Optional fieldbus connection	56
3.3.14.1	PROFIBUS DP	56
3.3.14.2	PROFINET IO	57
3.3.14.3	Modbus RTU	60
3.3.14.4	Modbus TCP	63
3.3.15	Pre-switch mode power supply 300 W.....	65
3.3.16	Water cooling	66
3.3.16.1	General information about water cooling	66
3.3.16.2	Direct water cooling diagram	67
3.3.16.3	Connecting water cooling.....	68
3.3.16.4	Venting the water cooling.....	68
3.3.16.5	Decommissioning and shutdown	69
3.3.16.6	Cooling water additives for the closed inverter cooling with cooling unit (optional)	69
4	Preparations for use	71
4.1	Transporting inverter	71
4.2	Storage of the inverters	74
4.3	EMC	75
4.3.1	Install and connect in accordance with EMC.	75
4.3.2	Examples for correct EMC connection	76
4.3.3	Radio interference class	78
4.3.4	EMC environment category.....	79
4.4	Realizing operation in the explosion-protected zone.....	80
5	Installation.....	83
5.1	Installing inverter - General notes.....	83
5.2	Installing compact devices	84
5.3	Protective cover IP21 for compact and compact Plus devices	85
5.4	Installing cabinet units.....	86
5.5	Mounting an external display (option).....	88

6	Electrical connection	91
6.1	General information about the electrical connection	91
6.2	Protecting the inverter	92
6.3	Circuit breaker	92
6.4	Connecting control cable	93
6.5	Line supply connection	93
6.5.1	Suitable supply line configurations	93
6.5.2	Dimensioning mains power cables	94
6.5.3	RCD circuit breaker	94
6.5.4	Connecting mains power cable to the inverter.....	95
6.5.5	Inverter connection for different pulse operation.....	96
6.5.6	Adjusting the line voltage at the inverter.....	96
6.5.7	Precharging	97
6.6	Motor connection	98
6.6.1	Motor selection	98
6.6.2	Coil load	98
6.6.3	Motor voltage and type of circuit	98
6.6.4	Dimensioning motor cables.....	99
6.6.5	Dimensioning maximum motor cable length	99
6.6.6	Connecting motor cable.....	101
6.6.7	Overload and overtemperature protection of the motor	102
6.7	External control voltage	102
6.7.1	Use of external control voltage.....	102
6.7.2	Connecting the external 230 V AC control voltage.....	103
6.7.2.1	Protecting/fusing the external 230 V AC control voltage	103
6.7.2.2	Switching over the hardware to an external 230 V AC control voltage.....	103
6.7.2.3	Preparations for accessing the "switching power supply" board.....	104
6.7.2.4	Connecting the external 230 V AC for compact devices	111
6.7.2.5	Control voltage 230 V AC for cabinet units	111
6.7.3	Connecting the external 24 V DC control voltage.....	112
6.7.3.1	Protecting/fusing the external 24 V DC control voltage	112
6.7.3.2	Switching over the hardware to an external 24 V DC control voltage	113
7	Commissioning	115
7.1	Checks without mains power supply and without motor.....	115
7.2	Checks with mains power supply and without motor	117
7.3	Checks with mains power supply and with motor	121
7.4	Checking with motor coupled to the work machine	122
8	Operation.....	123
8.1	Operation	123
8.1.1	Function of the inverter display.....	123
8.1.2	Switching the unit on and off.....	125
8.1.3	Setting the language	125
8.1.4	Setting the date and time.....	126
8.1.5	Setting the level of detail of the inverter menu.....	126
8.1.6	Inverter operating commands	126

8.1.7	Configuring operating sources	128
8.1.8	Invoking mode configurations.....	128
8.1.9	Communication Options	129
8.1.10	Meaning of the abbreviations for operating functions	130
8.1.11	"P-fieldbus" function	130
8.1.12	"P-DIGITAL OUTPUTS" function	130
8.1.13	"P-ANALOG OUTPUTS" function	131
8.1.14	Operation of several inverters on one PC.....	131
8.1.15	Communication via PROFINET IO.....	132
8.1.15.1	Communication services and port numbers used for PROFINET IO.....	132
8.1.15.2	Overview.....	133
8.1.15.3	Network security	133
8.1.15.4	Separation between production and office networks.....	134
8.1.15.5	Network segmentation with SCALANCE S.....	135
8.2	Standard mode settings	135
8.2.1	Operation "std siss"	135
8.2.2	Operation "std sisd".....	136
8.2.3	Operation "std dids"	137
8.2.4	Operation "std didd".....	138
8.3	NAMUR mode settings	138
8.3.1	Operation according to NAMUR defaults	138
8.3.2	Operation according to "Namur 1".....	139
8.3.3	Operation according to "Namur 2".....	140
8.3.4	Operation according to "Namur 3".....	141
8.3.5	Operation according to "Namur 4".....	142
8.3.6	Operation according to "Namur 5".....	143
8.3.7	Operation according to "Namur 6".....	144
8.4	Controlling the external connections of the inverter	145
8.4.1	Function of the control cable terminals	145
8.4.2	Protective separation according to EN 61800-5-1	145
8.4.3	Sub-D and USB connections and DIL switches.....	148
8.4.4	USB interface.....	149
8.4.5	DIL switches "S1" and "S2".....	149
8.4.6	Connecting encoders	151
8.4.7	Connect the PC via USB at -X50B.....	153
8.4.8	Connecting a PC to -X51 via RS 232.....	154
8.4.9	Connection for optional external display with RS 485	155
8.5	Special functions	156
8.5.1	Protective functions.....	156
8.5.2	Multiple function of the analog and digital inputs.....	160
8.6	Setpoint channel and closed-loop control.....	164
8.6.1	Specifying source for speed setpoint	164
8.7	Parameterization	164
8.7.1	Principle of operation of the configuration	164
8.7.2	Protecting parameters against modification	166
8.7.3	Configuration using the inverter display	166
8.7.4	More documentation about parameterization	167

8.8	Examples / Applications	168
8.8.1	"Standard" application.....	168
8.8.1.1	Standard control cable terminals.....	168
8.8.1.2	Control cable terminals "peripheral board 1".....	169
8.8.1.3	Control cable terminals "peripheral board 2".....	169
8.8.1.4	Control cable terminals "peripheral board 3".....	170
8.8.1.5	Control cable terminals "peripheral board 4".....	171
8.8.1.6	Operation setting for the "Standard" application	171
8.8.1.7	Assignment of the digital inputs.....	172
8.8.1.8	Assignment of the digital outputs	172
8.8.1.9	Assignment of the analog inputs.....	172
8.8.1.10	Assignment of the analog outputs.....	173
8.8.1.11	Input "Safe torque off" / PTC thermistor inputs on peripheral board	173
8.8.2	"Namur" application.....	175
8.8.2.1	Control cable terminals for the "Namur" application.....	175
8.8.2.2	Control cable terminals "peripheral board 4".....	176
8.8.2.3	Operation setting of the "Namur" application	178
8.8.2.4	Assignment of the relay outputs.....	178
8.8.2.5	Assignment of the analog inputs.....	178
8.8.2.6	Assignment of the analog outputs.....	179
8.8.2.7	Input "Mandatory mains power isolation" / PTC thermistor inputs on peripheral board.....	179
9	Maintenance.....	181
9.1	Maintenance and servicing	181
9.2	Replacing compact device.....	182
9.3	Replacing fans for the compact device.....	183
9.4	Maintenance and service of water cooling (option)	183
9.5	Decommissioning	183
10	Spare parts.....	185
10.1	Non-approved spare parts.....	185
10.2	Spare parts	185
11	Diagnostics, faults and warnings	187
11.1	Reading event log	188
A	Service & Support	189
A.1	Siemens Industry Online Support	189
B	Quality documents	191

C	Technical data	193
C.1	Conformity	193
C.2	Technical data for transportation	194
C.3	Technical data for storage.....	194
C.4	Technical data for operation	195
C.5	Frame sizes of compact units	196
C.6	Frame sizes of cabinet units	198
C.7	Tightening torques for power cables	201
C.8	Technical data of the control cable terminals.....	201
C.9	Technical data and identification of the PTC thermistor input at peripheral boards 2 and 4	203
C.10	Technical data of the direct water cooling	204
C.11	Permissible substance values for the cooling water.....	205
C.12	Threshold values for fan control system	206
C.13	Derating	206
C.13.1	Current derating	206
C.13.2	Voltage derating	209
D	List of abbreviations	211
	Index.....	213

Introduction

1.1 About these instructions

These Operating Instructions describe the device and provide you with information about handling it - from the initial shipment up to disposal. Keep these instructions for later use.

Read these Operating Instructions and comply with the information provided in them. In this way you can ensure safe, problem-free operation and a long service life.

Safety information and handling-related warnings are provided in these Operating Instructions. For your own safety, the safety of other persons and to avoid material damage, carefully follow these instructions when carrying out any work.

If you have suggestions for improving the document, please contact our Service Center.

1.2 Intended use

The products described in this manual, together with software, accessories and options, form an electric drive to supply low-voltage, three-phase motors. The products are intended for use in industrial environments. The products must be installed and maintained by professionals with sufficient knowledge to implement the safety and EMC measures in accordance with the specifications described in this manual and the recognized state-of-the-art engineering practices.

You may only use the products in compliance with the following requirements:

- All regulations and directives that are applicable at the place of final use, especially with regard to electrical safety, functional safety and electromagnetic compatibility.
- All instructions, notes, technical data and safety information contained in this manual and other supporting documentation.

Before using the products, you must perform a risk assessment of the entire application and implement appropriate system design measures to ensure the safety of persons, property and electromagnetic compatibility.

Open type products (IP00 / IP20) are intended for installation in electrical rooms, control cabinets or housings, which provide the necessary protection.

Any use other than that expressly permitted is prohibited, and can result in unforeseen dangers.

1.3 Validity

This document is applicable for SINAMICS G180 T7 (not capable of energy recovery), Order No. "6SE01...", from software version 11C0242/CR88

1.4 Text format features

Text format features

You can find the following text format features in these instructions:









1. Handling instructions are always formatted as a numbered list. Always perform the steps in the order given.
- Lists are formatted as bulleted lists.
 - Lists on the second level are hyphenated.

Note

The note provides you with additional information about the product itself, handling the product - and the relevant documentation.

1.5 Presentation of the display buttons in the operating instructions

Table 1- 1 Presentation of the display buttons in the text

Button on the inverter display	Presentation in the text
	<On>
	<Off>
	<P>
	<S>
	<I>
	<ENTER>
	<up arrow>
	<down arrow>

1.6 Specific features

The following text formats are used in this operating manual.

Display buttons

Table 1- 2 Display of special markings

Description in the text	Meaning
<Arrow up>	Press the button on the control panel once.
<Arrow up_ Arrow up>	Press the button on the control panel twice.
<S+I>	Press both buttons simultaneously.

Display text

"P-SYSTEM DATA"

Text shown in the control panel display is presented like this.

If you must branch in a menu, then the text is displayed as follows:

"P-OPERATION/P-ContrlRelease/Local". "P-OPERATION" symbolizes the main menu,

"P-ContrlRelease" a submenu and "Local" the parameter.

In this case, in the appropriate menu, parameterize the controller enable if the operating source is set to "Local".

Several submenus can be nested.

Safety information

2.1 The five safety rules

For your personal safety and in order to prevent material damage it is essential that you adhere to all the safety notices contained in your product documentation. Pay particular attention to the safety notices on the product itself. When working on the equipment, always observe the following five safety rules as defined by EN 50110-1 "Working in a voltage-free state". Apply the five safety rules in the sequence stated before starting work.

Five safety rules

1. Disconnect the system.
Disconnect the auxiliary circuits, for example anti-condensation heating.
Wait until the capacitors have discharged.
2. Lockout to protect against reconnection.
3. Make sure that the equipment is de-energized and in a no-voltage condition.
4. Ground and short-circuit.
5. Cover or enclose adjacent components that are still live.

When you have finished working on the equipment, apply the measures in reverse order.



DANGER

High voltages

Potentially fatal voltages occur when this equipment is in operation which can remain present even after the inverter is switched off.

High voltages cause death, serious injury or material damage if the safety instructions are not observed or if the equipment is handled improperly.

- Ensure that only qualified and authorized personnel perform work on the inverter.
- Always observe the five safety rules specified above whenever you are carrying out any work on the device.

2.2 Use of tested, certified and Siemens-approved components

Observe the following instructions if you would like to integrate your own components in the system.

 **WARNING**

Components which are not approved

It is dangerous to use components which are not tested, not certified and not approved by Siemens. This can result in death, serious injury or material damage.

- Use only components which are tested, certified and approved by Siemens.

2.3 Areas that are potentially and particularly hazardous

Certain areas in the inverter can represent a hazard during operation. The diagram highlights these areas that represent a potential hazard.

Observe the following safety notices and comply with all rules and instructions.

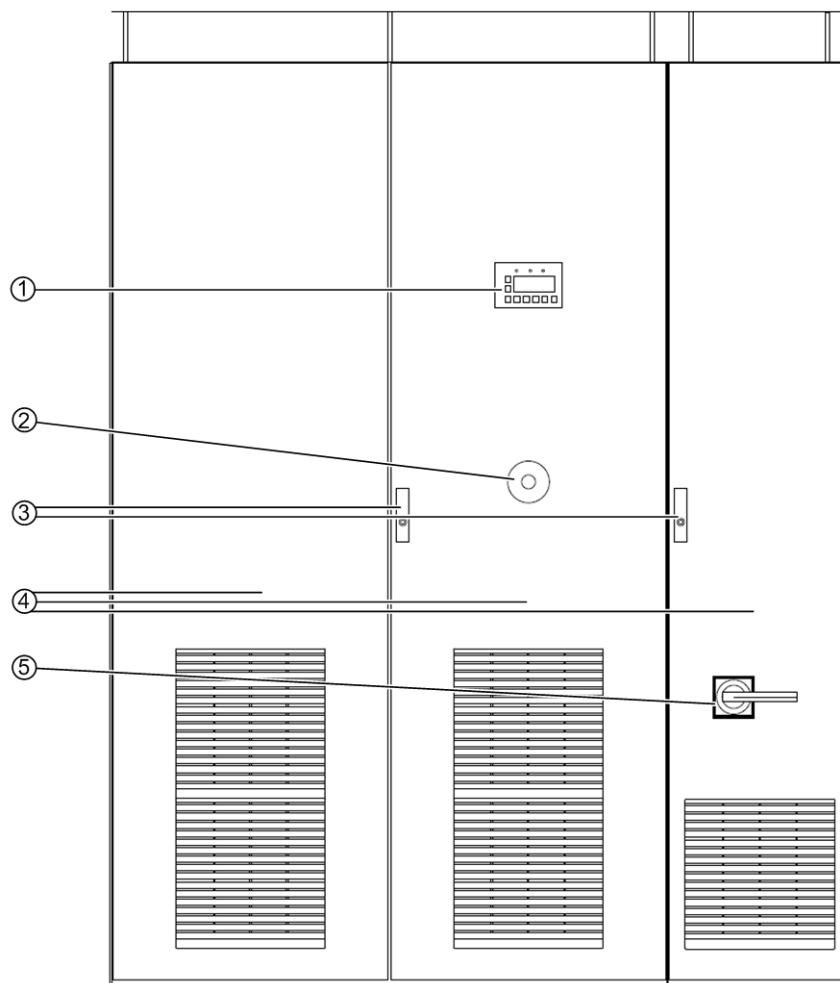

- ① Stopping the inverter via the display or by means of external control devices does not disconnect the inverter from the line voltage.
- ② When you press the EMERGENCY OFF button, this does not mean that the converter is voltage-free immediately.
- ③ Danger due to hazardous voltages when the cabinet doors are open.
- ① These voltages can remain due to self-excitation if the connection to the motor is not removed. Some surfaces in the inverter are hot during operation and for some time afterwards. Fans in the inverter can continue to rotate after the unit has been switched off.
- ⑤ After disconnection of the line voltage, hazardous voltages can persist in the DC link (with current-source DC link converters: in the commutation capacitors) or from external or auxiliary power sources after the converter has been disconnected from the line voltage. Depending on parameter settings and connection of external control devices, the inverter can start up automatically when the line voltage is connected.

Figure 2-1 Areas that are potentially and particularly hazardous



! WARNING

Live components

During operation and shortly after the system has been switched off with the EMERGENCY OFF button, high voltages are still present in the converter and its components. These voltages may remain if the connection to the motor is not removed or grounded. This danger exists with permanent-magnet synchronous motors and synchronous motors which are not de-excited immediately. These voltages may remain if the connection to the motor is not removed or grounded. High voltages cause death or serious injury if the safety instructions are not observed or if the equipment is handled improperly.

Never open the covers or doors when the system is in operation or while the DC link capacitors are still discharging (in the case of current-source DC link inverters: commutation capacitors). The DC link capacitors (commutation capacitors) can take up to 10 minutes to discharge (or 5 minutes with compact devices) after the EMERGENCY OFF button is actuated.

! WARNING

Automatic startup

Depending on parameter settings and connection of external control devices, the inverter can start up automatically when the line voltage is connected. This can result in death, serious injury or material damage.

Confirm whether or not your system is capable of automatic starting and, if appropriate, take measures to ensure personal safety and operational readiness at the driven machine.

2.4 Notes for operator protection

Read the following information about personal protection.

The device complies with safety requirements according to EN 61800-5-1:2007/A1:2017 and EN 61800-5-1/A11:2021.

Specialist personnel

Ensure that any transport, installation, operation or maintenance work is carried out by **qualified, trained staff**. The minimum qualification must be that of an electrician in accordance with EN 50110 "Operation of electrical systems".

For the purpose of these basic safety instructions, "skilled technical personnel" means people who are familiar with the installation, mounting, commissioning and operation of the product. They must be properly qualified for the tasks with which they are charged. Qualified personnel must also be thoroughly familiar with all the safety-related instructions and measures described in the product documentation.

Safety-relevant instructions and information about working on the converter



DANGER

Live, moving or rotating parts

Converters have live, moving and rotating parts.

Death or serious injury can result if any essential covers are removed without authorization or in the case of improper use or incorrect installation or operation.

Always take all the necessary precautions before working on the device.



DANGER

High voltages

High voltages cause death or serious injury if the safety instructions are not observed or if the equipment is handled improperly.

Voltages of more than 50 V are present when this unit is operational. These voltages may remain for some time after switching off or as long as the motor is turning over.

Make sure that work is only carried out by qualified personnel under due observance of the five safety rules, the information in these operating instructions, and the instructions on the product itself.



DANGER

Auxiliary and external supply systems

Hazardous voltages (e.g. control voltage, signal voltage, supply voltage for heaters and fans) can persist even after the converter has been switched off. Contact with live parts can result in death or serious injury.

Make sure that work is only carried out by qualified personnel under due observance of the five safety rules, the information in these operating instructions, and the instructions on the product itself.



DANGER

Electric shock

If you carry out maintenance or overhaul work on the converter without safely disconnecting the power supply, serious injury or death due to electric shock can occur. The PTC input is not an Emergency Off input that safely disconnects the converter or the motor from the line supply.

Safely and reliably disconnect the power supply before opening covers or terminal boxes at the converter. For example, use a main switch.



! DANGER

High voltages

Electrical accidents including electric shock occur when general safety instructions for working on the device are not observed. Death, serious injury or material damage will result.

Please note the following information for your safety:

- Keep to the five safety rules at all times and at every stage of work.
- Always disconnect the equipment before working on it.
- Leave the covers in place during normal operation and keep the cabinet doors closed.
- Do not use any instrumentation if you know it is defective or damaged.
- Secure the main circuit breaker in the OFF position so that it cannot be reconnected, for example by removing the switch unit when working on a connected motor or the feeder cable to the motor.
- Ground the converter cabinet and installed devices properly to ensure that no accessible parts of the device are energized (live) or connected in any way to another dangerous voltage source.
- Use an earthing spider for grounding purposes. Read the information provided in the section "Safety instructions regarding maintenance and repairs" in "Maintenance and servicing" in your operating instructions.
- Wear personnel protective gear such as goggles, ear protection and helmet to protect yourself against injury.
- Always follow the national regulations and local specifications when working on the equipment.



! DANGER

DC link capacitor discharge time

After the mains voltage has been switched off, high voltages still persist in the DC link capacitors.

These cause death or serious injury if the safety instructions are not observed or if the equipment is handled incorrectly.

The DC link capacitors require up to 10 minutes (5 minutes for compact units) before they are discharged to a safe value (< 60 V).

After you have switched off the mains voltage, do not touch the device or carry out any maintenance work or repair work until the discharge time of 10 minutes (5 minutes for compact devices) have elapsed.

Measure the voltage once the discharge time has elapsed.



! CAUTION

Hot surfaces

Certain components (e.g. the heat sink or filter reactor) can become very hot during operation. These components can remain hot for a long time after operation.

The optional anti-condensation heating is activated when the converter is not operating and the limit value set at the temperature control is reached. Once activated, the anti-condensation heating can generate a great deal of heat.

Contact with hot surfaces can cause injuries (such as burns to the skin).

Never touch hot components just after you have switched off the converter. Always take the appropriate precautions before touching any components.

2.5 Notes on liquid cooling

Follow the safety instructions for liquid-cooled converters.



! WARNING

Electric shock as a result of defective cooling liquid system

Short circuits can develop in electrical installations when liquid escapes from cooling circuits. This can result in death, serious injury or material damage.

- Note the technical data of the liquid cooling system. This data is provided in Chapter "Technical data of the direct water cooling (Page 204)" and the technical data sheet.
- Observe the information in Chapter "Permissible substance values for the cooling water (Page 205)".
- Observe the information in Chapter "Water cooling (Page 66)".
- Protect the cooling liquid circuits against excess pressure, e.g. by installing a relief valve.
- Make sure that the pipework installation and pressure testing procedures comply with local safety regulations and national safety guidelines.

2.6 Safety precautions when handling anti-freeze

 **CAUTION**

Physical injury caused by burns or poisoning is possible

Antifreeze is harmful to health. Inhalation or swallowing can lead to burns or poisoning.

Observe the following health and safety precautions when handling antifreeze:

- Do not inhale vapors.
- Keep the antifreeze away from food and beverages.
- Wear protective gloves and safety goggles.
- Avoid contact with skin and eyes.

NOTICE

Leaking antifreeze has a corrosive effect and may cause short-circuits.

When a connection is disconnected in the cooling circuit, antifreeze can escape and drip down onto lower areas. These areas can corrode and therefore cause short-circuits.

Whenever you disconnect a connection in the cooling circuit, cover lower areas. Thoroughly remove antifreeze from areas that it has come into contact with and clean. Completely remove all residues.

NOTICE

Impurities in the cooling circuit can cause converter modules to fail

When carrying out any work on the cooling circuit, ensure that no impurities (e.g. dust, sand, fluff, chips, etc.) are able to enter the cooling circuit. Make sure that all containers and hoses, with which you handle the antifreeze are clean and are exclusively used for the antifreeze.

First aid measures

The following table lists the first aid measures:

Table 2- 1 Antifreeze: First aid measures

Event	Measure
Wetted clothing	Remove clothing immediately.
Skin contact	Wash off immediately with plenty of water.
Eye contact	Rinse thoroughly and immediately with plenty of water and seek medical advice.
If swallowed	If the affected person is completely conscious, immediately induce vomiting. In any case, consult a doctor.

In addition, observe the provisions of the EC safety data sheet in accordance with 91/155/EEC, as well as the generally applicable first aid rules.

2.7 Standards and guidelines for proper use of inverters

Inverters are components designed for installation in electrical systems or machines.

Commissioning of the inverters is prohibited until one of the following two conditions is verifiably fulfilled.

- The machine complies with the requirements of the following directives:
 - Machinery Directive 2006/42/EG
 - EMC Directive 2014/30/EU
- The electrical installation complies with the requirements of the following directives:
 - Low-Voltage Directive 2014/35/EU
 - EMC Directive

The inverters comply with the requirements of the Low-Voltage Directive 2014/35/EU and the EMC Directive 2014/30/EU.

To ensure that this equipment functions perfectly and safely, observe the following:

- Transportation in accordance with proper procedures
- Proper storage
- Proper installation and assembly
- Careful operation
- Careful maintenance

The unit must only be used for the applications specified in the catalog and only in conjunction with devices and components recommended and approved by Siemens.

Note

Familiarize yourself with the local safety requirements and national safety guidelines and always observe them.

2.8 Plant safety

Read the following information about safeguarding the equipment.

 DANGER
Unsecured installation site
<p>This inverter is intended for use in industrial power installations and machines. Accidents can occur if the equipment is not used for the intended purpose, is incorrectly operated, is inadequately maintained or can be accessed by unauthorized persons. Death, serious injury or material damage will result.</p> <p>Secure the installation site against unauthorized access when using the inverter outside industrial areas using suitable equipment (e.g. safety fences) and corresponding signage. Install the inverter in a suitable area to which only properly trained personnel have access.</p>

Procedure

You are responsible for the safety of the system.

You must ensure that the following requirements are fulfilled:

- Basic planning and all the work involved in transporting, assembling, installing, commissioning, maintaining and repairing the equipment is only carried out by qualified personnel or personnel supervised by responsible skilled technicians.
- The operating instructions and the complete product documentation are always available when carrying out any work.
- The technical data and specifications regarding the permissible installation, connection, environmental, and operating conditions are observed consistently.
- The system-specific installation and safety regulations are observed and measures are taken to ensure personal safety.
- It is prohibited for unqualified persons to work on these devices or in their vicinity.

The product documentation, especially the operating instructions, and the notices on the unit itself therefore contain only the information required by qualified personnel to use the installations or machines for their intended purpose.

Note

Siemens Service Centers

The services and support provided by the Siemens service centers are recommended for planning, installation, commissioning, and servicing work.

Note

Engineering information

Systems in which the inverters are installed must be fitted with additional monitoring and safety devices in order to comply with safety requirements (e.g. equipment and product safety law, accident prevention regulations).

2.9 Security information

Siemens provides products and solutions with industrial security functions that support the secure operation of plants, systems, machines and networks.

In order to protect plants, systems, machines and networks against cyber threats, it is necessary to implement – and continuously maintain – a holistic, state-of-the-art industrial security concept. Siemens' products and solutions constitute one element of such a concept.

Customers are responsible for preventing unauthorized access to their plants, systems, machines and networks. Such systems, machines and components should only be connected to an enterprise network or the internet if and to the extent such a connection is necessary and only when appropriate security measures (e.g. firewalls and/or network segmentation) are in place.

For additional information on industrial security measures that may be implemented, please visit

<https://www.siemens.com/industrialsecurity>.

Siemens' products and solutions undergo continuous development to make them more secure. Siemens strongly recommends that product updates are applied as soon as they are available and that the latest product versions are used. Use of product versions that are no longer supported, and failure to apply the latest updates may increase customer's exposure to cyber threats.

To stay informed about product updates, subscribe to the Siemens Industrial Security RSS Feed under

<https://www.siemens.com/cert>.

2.10 Components that can be destroyed by electrostatic discharge (ESD)

 **WARNING**

Unsafe operating states resulting from software manipulation

Software manipulations (e.g. viruses, trojans, malware or worms) can cause unsafe operating states in your system that may lead to death, serious injury, and property damage.

- Keep the software up to date.
- Incorporate the automation and drive components into a holistic, state-of-the-art industrial security concept for the installation or machine.
- Make sure that you include all installed products into the holistic industrial security concept.
- Protect files stored on exchangeable storage media from malicious software by with suitable protection measures, e.g. virus scanners.

 **WARNING**

Malfunctions of the machine as a result of incorrect or changed parameter settings

As a result of incorrect or changed parameterization, machines can malfunction, which in turn can lead to injuries or death.

- Protect the parameterization (parameter assignments) against unauthorized access.
- Handle possible malfunctions by taking suitable measures, e.g. emergency stop or emergency off.

2.10 Components that can be destroyed by electrostatic discharge (ESD)

ESD guidelines

Material damage caused by electrostatic discharge.

Electronic components can be destroyed in the event of improper handling, transport, storage, and shipping.

Pack the electronic components in appropriate ESD packaging; e.g. ESD foam, ESD packaging bags and ESD transport containers.

2.10 Components that can be destroyed by electrostatic discharge (ESD)

To protect your equipment against damage, follow the instructions given below.

- Avoid physical contact with electronic components. If it is essential that you perform work on these components, you must wear one of the following pieces of protective gear:
 - Grounded ESD wrist strap
 - ESD shoes or ESD shoe grounding strips if there is also an ESD floor.
- Do not place electronic components close to data terminals, monitors or televisions. Maintain a minimum clearance to the screen (> 10 cm).
- Electronic components should not be brought into contact with electrically insulating materials such as plastic foil, plastic parts, insulating table supports or clothing made of synthetic fibers.
- Bring components into contact only with ESD-compliant materials, e.g. ESD tables, ESD surfaces, ESD packaging.
- Only carry out measurements on the components if one of the following conditions is met:
 - The measuring device is grounded with a protective conductor, for example.
 - The measuring head of a floating measuring device has been discharged directly before the measurement.

The necessary ESD protective measures for the entire working range for electrostatically sensitive devices are illustrated once again in the following drawings.

Precise instructions for ESD protective measures are specified in the standard DIN EN 61340-5-1.

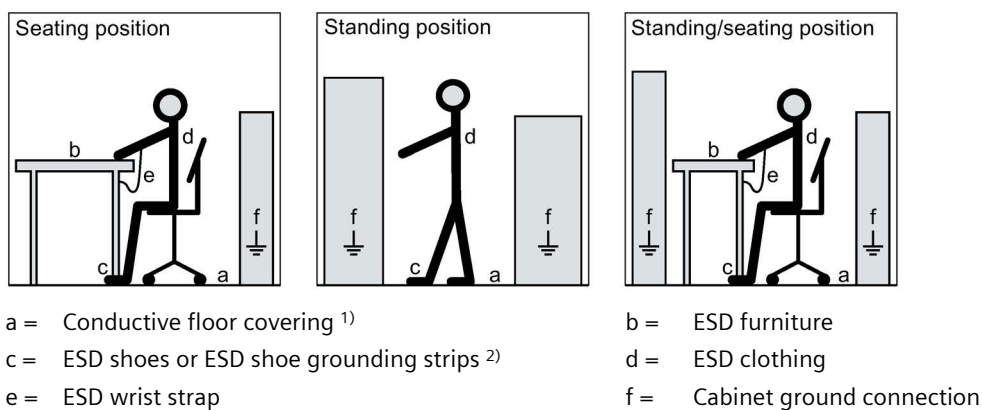

¹⁾ Only effective in conjunction with ESD shoes or ESD shoe grounding strips

²⁾ Only effective in conjunction with conductive floor covering

Figure 2-2 ESD information

2.11 Electromagnetic fields

 **WARNING**

Electromagnetic fields "electro smog"

Electromagnetic fields are generated when electrical equipment (e.g. transformers, inverters, motors etc.) is operated.

Electromagnetic fields can interfere with electronic devices, which could cause them to malfunction. For example, the operation of heart pacemakers can be impaired, potentially leading to damage to a person's health or even death. It is therefore forbidden for persons with heart pacemakers to enter these areas.

The plant operator is responsible for taking appropriate measures (labels and hazard warnings) to adequately protect operating personnel and others against any possible risk.

- Observe the relevant nationally applicable health and safety regulations. In Germany, "electromagnetic fields" are subject to regulations BGV B11 and BGR B11 stipulated by the German statutory industrial accident insurance institution.
- Display adequate hazard warning notices.



- Place barriers around hazardous areas.
- Take measures, e.g. using shields, to reduce electromagnetic fields at their source.
- Make sure that personnel are wearing the appropriate protective gear.

2.12 Radio telephones and mobile telephones

Safety instructions

 CAUTION
Radio telephones If you use radio communication equipment > 2 W in close proximity to the inverter, damage to equipment of the type specified below can occur and possibly result in physical injuries to personnel: <ul style="list-style-type: none">• Missing pulses during inverter operation can occur.• Defects of the power elements can occur.• The inverter can shut down.• Contactors can chatter.• Interference on binary outputs. Do not use radio telephones > 2 W in close proximity to the device. Radio telephones with lower outputs must not be used at a distance of less than 1 m from the inverter.

 CAUTION
Mobile telephones The use of mobile telephones near the inverter when it is in operation can result in the generation of erroneous pulses and possibly give rise to physical injuries to personnel. Switch off mobile telephones when you are near the device.

2.13 Note regarding fiber-optic cables

Fiber-optic cable systems are used in some inverters. Please observe the following warning.



Figure 2-3 Photography prohibited

CAUTION

Erroneous pulses in fiber-optic cables

Erroneous pulses in fiber-optic cables caused by camera flash lights can result in malfunction and damage to the inverter and motor and potentially result in injury to personnel.

It is not permissible to photograph inverters with fiber-optic cable systems using a camera flash light when they are in operation! Only photograph these types of inverters when they are in a no-voltage state.

2.14 Protecting/fusing the external 230 V AC control voltage

WARNING

External control voltage without fuse protection

If you use an external control voltage without suitable protection (e.g. fuses), then overloads and short-circuits can occur. This can result in death, serious injury or material damage.

The device may only be operated with a protected external control voltage. Note the following recommendation.

Install one of the following options to protect the external control voltage:

- Miniature fuse in accordance with EN 60127: 2 A ... 6 A, slow, maximum 150 VA
- Miniature circuit-breaker: 2 A ... 6 A, characteristic D, maximum 150 VA

2.15 Residual risks of power drive systems

When assessing the machine or system-related risk in accordance with the respective local regulations (e.g. EC Machinery Directive), the machine manufacturer or system integrator must take into account the following residual risks emanating from the control and drive components of a drive system:

1. Unintentional movements of the driven machine or system components during commissioning, operation, maintenance, and repairs caused by, for example:
 - Hardware faults and/or software errors in the sensor technology, control system, actuator technology, and connection system
 - Response times of the controller and drive
 - Operation and/or environmental conditions outside the specifications
 - Condensation/conductive contamination
 - Parameterization, programming, cabling, and installation errors
 - Use of wireless devices/mobile phones in the immediate vicinity of electronic components
 - External influences/damage
 - X-rays, ionizing radiation and cosmic radiation
2. Unusually high temperatures, including open flames, as well as emissions of light, noise, particles, gases, etc. can occur inside and outside the components under fault conditions caused by, for example:
 - Component malfunctions
 - Software errors
 - Operation and/or environmental conditions outside the specifications
 - External influences/damage
 - Short circuits or ground faults in the intermediate DC circuit of the converter
3. Hazardous shock voltages caused by, for example,
 - Component malfunctions
 - Influence during electrostatic charging
 - Induction of voltages in moving motors
 - Operation and/or environmental conditions outside the specifications
 - Condensation/conductive contamination
 - External influences/damage
4. Electrical, magnetic and electromagnetic fields generated in operation that can pose a risk to people with a pacemaker, implants or metal replacement joints, etc., if they are too close
5. Release of environmental pollutants or emissions as a result of improper operation and/or failure to dispose of components safely and correctly

2.15 Residual risks of power drive systems

6. Influence on communication systems via the line supply, e.g. ripple-control transmitters or data communication via the line supply

7. Motors for use in potentially explosive areas:

When moving components such as bearings become worn, this can cause enclosure components to exhibit unexpectedly high temperatures during operation, creating a hazard in areas with a potentially explosive atmosphere.

For more information about the residual risks of power drive system components, see the relevant sections in the technical user documentation.

Description

3.1 Updating inverter software or instructions

These operating instructions are valid for SINAMICS G180, software version 11C0242/CL88 and higher.

Procedure

1. At the converter display, check the current software version of the converter in menu "I-CONVERTER DATA/Version".
2. If the converter software version is higher than the version in the operating manual, download the current version of the manual from here (<http://www.siemens.com>).
3. If the converter software is no longer current, then update the converter software using the "IMS" software.

For more detailed information, contact the Siemens Service Center, see Service & Support (Page 189).

3.2 Order numbers MLFB / Type designations

The converters have the following types of identification:

- Order No. MLFB
- Type code
- Other version designation

Order number MLFB (machine-readable product designation)

e.g. 6SE0100-1AG31-0AA7-Z +G05

What the icons mean:

Example	Designation	Option	Meaning
6SE01	1st - 5th position: device type, product group	6SE01	SINAMICS G180
0	6th position: Mechanical design	0	Compact device with air cooling
		4	Cabinet with compact units
		7	Cabinet unit with water cooling
		8	Cabinet unit with air cooling
0	7th position: Unassigned	0	all SINAMICS G180 industrial converters
-			
1	8th position: Harmonic effects on power system	0	Not relevant for cabinet
		1	6-pulse input
		2	12-pulse input
		3	18-pulse input
		4	24-pulse input
A	9th position: Number of systems connected in parallel	A	Compact unit
		B	Single device with system management
		C	Multiple device with 2 parallel circuits
		D	Multiple device with 3 parallel circuits
		E	Multiple device with 4 parallel circuits
		F	Not relevant for cabinet
		G	Multiple device with 5 parallel circuits
		H	Multiple device with 6 parallel circuits
		J	Multiple device with 7 parallel circuits
		K	Cabinet with one compact unit
		L	Cabinet with 2 identical compact units
		M	Cabinet with 3 identical compact units
		G	10th position: Supply voltage
B	Restricted application: 230 ... 415 V 3 AC IT, 50 ... 60 Hz		
C	230 ... 500V 3 AC TN/TT, 50 ... 60 Hz		
D	230 ... 500 V 3 AC IT, 50 ... 60 Hz		
G	230 ... 600/690 V 3 AC ¹⁾ TN/TT, 50 ... 60 Hz		
H	230 ... 600/690 V 3 AC ¹⁾ IT, 50 ... 60 Hz		
J	850 ... 950 ... 990 V 3 AC		
K	1000 V 3 AC		
L	Independent of voltage		
M	1140 V 3 AC		

Example	Designation	Option	Meaning	
3	11th position: Multiplier for output current	0	* 0.01	
		1	* 0.1	
		2	* 1	
		3	* 10	
		4	* 100	
1 - 0	12th + 13th position: First two digits of output current	...	Two positions for approximate specification of the output current, e.g.: 11th position = 3, 12th position = 8, 13th position = 2 means: Output current approx. 10 * 82 = 820 A. In the case of cabinets containing multiple compact units, the output current of the largest compact unit must be specified. It is not permissible to state the digit 9 here. If a converter has, for example, a rated current of 940 A, then the order number positions for the output current must be reduced. ⇒ 11th position = 3, 12th position = 8, 13th position = 8. This can mean that the order number of the next smaller unit is reduced as well. For example, if it had an output current of 890 A. ⇒ 11th position = 3, 12th position = 8, 13th position = 7	
A		14th position: Option module	A	IEC, EN
			U	NRTL-certified (by TÜV) and/or UL-certified
A	15th position: Customer or sector design	A	Standard	
		B	Customized design xyz1	
		C	Customized design xyz2	
7 -	16th position: Version / release number	7	Version/release number series 7	
Z	17th position: Z options	(blank)	no option available	
		Z	Z option available. The options included are specified in the 3-position extensions of the MLFB (+xxx). One or several options can be specified.	
(blank)				
+G05	+18th-20th position ... +(3-position) ...	+xxx	Specification of one or several integrated Z options, according to the Catalog SINAMICS G180 (D18.1 or newer) e.g. +G05 = peripheral board 4	

¹ With an NRTL unit ("U" in 14th position of order number), the voltage range ends at maximum 600 V, otherwise at 690 V.

Type code

e.g. 2T 2 A- 0 7 4 0 0- 055

The type code describes the converter type in more detail. Always state the type code as well as the serial number and other rating plate data for enquiries to the factory.

What the icons mean:

Example	Designation	Option	Meaning
2R	Device type	2R	4-quadrant voltage-source DC link converter SINAMICS G180
2T	Device type	2T	SINAMICS G180 voltage-source DC link converter
		2x	Cabinet unit system with one or more converters. The attainable shaft outputs of all installed converters are added together.
2	Degree of protection	1	IP00
		2	IP20
		3	IP21
		6	IP 54
		7	IP55
		9	Other
A -	Number of pulses in the input	A	6-pulse input
		F	12-pulse input
		K	18-pulse input
		L	24-pulse input
0	Mechanical design	0	Compact device with air cooling
		2	Compact device Plus with air cooling
		3	Compact device with water cooling
		7	Cabinet unit with water cooling
		8	Cabinet unit with air cooling
		9	Special version
7	Modification status	5	Modification status 5
		6	Modification status 6
		7	Modification status 7
4	Mains voltage	4	400 V unit
		5	500 V unit
		6	690 V unit
		9	950 V unit
0	Number of parallel line-converter systems	0	Single device without system management
		1	Single device with system management
		2 ... 7	Multiple device with corresponding number of parallel systems and system management units
0-	Number of parallel machine-converter systems	0	Single device without system management
		1	Single device with system management
		2 ... 7	Multiple device with corresponding number of parallel systems and system management units
055	Achievable shaft output [kW] for continuous output current	...	If the first position is 9, the other two digits show the power in kW * 100.

Other version designation

e.g. A type code O B D I M 4

The other version designation of the converter consists of the type code and seven other characters. This designation is specified on the rating plate. It is used in commercial written communication and is as follows:

Example	Designation	Option	Meaning
A	Accessories	A	Standard accessories
		D	Accessories with bypass for mains operation with direct activation
		N	Accessories according to NAMUR Guideline NE37 with Test-Normal switch
		Q	Accessories with main switch, external handle
		W	Accessories with main switch, internal handle
		S	Accessories with main switch, main contactor, EMERGENCY STOP in door and local/remote switch
		Z	Customer-specific accessories
2T2A-07400-055	Type code	Type codes of the converters	
O	Braking device	O	Converter without braking device
		B	Converter with braking device
		Y	Converter with braking device and electrical special design
		Z	Converter with electrical special design, e.g. design according to ZLU
B	RFI suppression filter	O	Without filter
		A	With radio interference class A filter, category C2 or C3
		B	With radio interference class B filter, category C1
		L	With radio interference class A filter and with LHF
		M	Without RFI suppression filter and with LHF
D	Converter output filter	D	Standard du/dt filter
		V	Strengthened du/dt filter
		S	Sine-wave filter
I	Internal converter display	O	Without internal converter display
		B	With internal and external converter display
		E	With external converter display
		I	With internal converter display
		R	With internal Russian converter display
		S	With external Russian converter display
		T	With internal and external Russian converter display
M	Bus board	O	Without bus board
		C	With CAN bus board
		F	With PROFINET board (SCRJ fiber optic connection)
		M	With Modbus RTU board
		N	With PROFINET board (RJ45 copper connection)
		P	With PROFIBUS board
		T	With Modbus TCP-IP board
4	Peripheral board	O	Without peripheral board
		1	With peripheral board 1
		2	With peripheral board 2
		3	With peripheral board 3
		4	With peripheral board 4

3.3 Accessories

3.3.1 Use of tested, certified and Siemens-approved components

Observe the following instructions if you would like to integrate your own components in the system.



WARNING

Components which are not approved

It is dangerous to use components which are not tested, not certified and not approved by Siemens. This can result in death, serious injury or material damage.

- Use only components which are tested, certified and approved by Siemens.

3.3.2 Peripheral boards 1 to 4, -A95, option G02 to G05

3.3.2.1 General information about the peripheral boards 1 to 4

Motherboards:



Peripheral board AO



Peripheral board DI/DO

Daughter board:



Peripheral board PTC thermistor

Example:

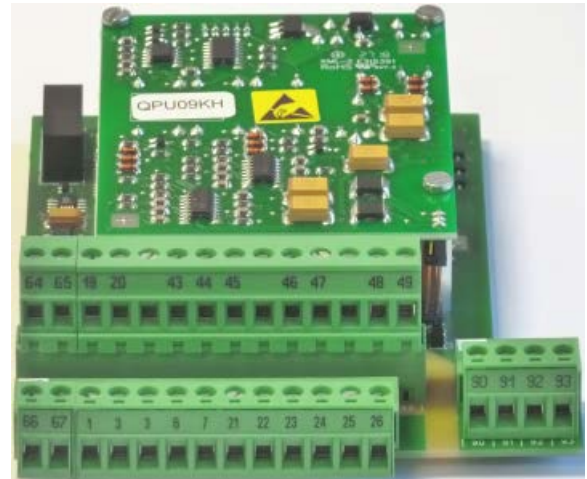

Peripheral board 4

There are 4 peripheral board versions as option. These comprise a motherboard peripheral board AO or peripheral board DI/DO and daughter board peripheral board PTC thermistor. Either one motherboard alone can be installed - or in combination with the daughter board.

The converter functionality is expanded using a peripheral board. 1 version of the peripheral board can be installed in each converter.

The functionality of the possible versions is listed in the following table.

Table 3- 1 Configuration of the peripheral boards

	Peripheral board 1	Peripheral board 2	Peripheral board 3	Peripheral board 4
2 PTC thermistor inputs, motor temperature monitoring for motors in hazardous areas <ul style="list-style-type: none"> • ATEX-certified once according to: DIN EN ISO 13849-1:2015, Cat. 2, PL c or DIN EN 61508-1:2010, SIL 1 • One for warning 	-	X	-	X
1 digital input "Safe torque off", STO, acc. to DIN EN ISO 13849-1:2015, Cat. 2, PL c or DIN EN 61508-1:2010, SIL 2 in conjunction with an additional digital input (2 circuit) acc. to DIN EN ISO 13849-1:2015, Cat. 3, PL d or DIN EN 61508-1:2010, SIL 2	-	-	X	X
9 digital inputs (DI)	-	-	X	X
3 relay outputs (DO)	-	-	X	X
2 analog outputs (AO)	X	X	X	X
Power supply unit, 24 V, 300 mA	-	-	X	X

Peripheral boards 2 and 4 are, in addition to the motherboard peripheral board AO or peripheral board DI/DO is also equipped with a daughter board peripheral board PTC thermistor, which accommodates the circuit for PTC thermistor inputs.

The connection diagram of these versions can be found in Chapter "Control cable terminals, peripheral board 1 (Page 169)".

Use the digital inputs and the analog outputs of the peripheral board corresponding to the inputs and outputs on the main terminal block. You can find additional information in Chapter "Standard control cable terminals (Page 168)".

Configure the three relay outputs corresponding to the relay outputs of the main terminal block. For additional information regarding electrical (galvanic) isolation, refer to Chapter "Protective separation in accordance with EN 61800-5-1 (Page 145)".

3.3.2.2 Electronic shutdown for "Safe halt" / PTC inputs

Standards for electronic shutdown

The electronic shutdown complies with the following standards:

- DIN EN ISO 13849-1:2015, Safety of Machinery; Safety-Related Parts of Control Systems - Part 1: General principles for design
- DIN EN ISO 13849-2:2012, Safety of Machinery; Safety-Related Parts of Control Systems - Part 2: Validation

- EN 50495:2010, Safety devices required for the safe functioning of equipment with respect to explosion risks
- DIN EN 60947-8:2013, Low-voltage switchgear and controlgear – Part 8: Tripping units for integrated thermal protection (PTC) for rotating electrical machines
- DIN EN 61508-1: 2010, Functional safety of electrical/electronic/programmable electronic safety-related systems – Part 1: General requirements
- DIN EN 61508-2: 2010, Functional safety of electrical/electronic/programmable electronic safety-related systems – Part 2: Requirements placed on safety-related electrical/electronic/programmable electronic systems
- IEC 61800-5-2:2016 - Adjustable-speed electrical power drive systems – Part 5-2: Requirements placed on safety – Functional safety
- IEC 62061:2005 + A1:2012, Safety of machinery – Functional safety of safety-related electrical, electronic and programmable electronic control systems
- IEC 62061-A2:2015, Safety of machinery – Functional safety of safety-related electrical, electronic and programmable electronic control systems; Revision 2

General information about electronic shutdown

Using the electronic shutdown concept of the inverter, a system without main contactor can be shut down. This also applies to motors operating in Hazardous Zone 1. In the case of a fault, the inverter electronically interrupts the power supply to the motor.

NOTICE

Malfunctions

If the inverter is used in safety-relevant applications with visible transport damage, malfunctions and damage to property can occur.

- Do not use inverters with visible transport damage.
- Peripheral boards 2/3/4 with safety-related inputs and an ATEX motor temperature monitoring must always be replaced using certified, original parts. Only replace parts after prior consultation with the factory.
- Use the "Safe torque off" function of the inverter for induction and synchronous motors. If two additional faults occur in the power section, for synchronous motors, this can result in residual rotation. The residual rotation angle can be maximum 180°. Calculate the residual rotation angle from $360^\circ / \text{number of poles } n$. Take into account residual rotation in your design. This does not apply to induction motors.

WARNING

Shutdown only when safety circuits are opened

The inverter is only shut down with the "Safe torque off" function as long as shutdown is initiated by opening the appropriate safety circuits. If the safety circuits are reclosed, safe shutdown is no longer given; this applies, even if the inverter does not immediately restart.

Shutdown concept ATEX motor temperature monitoring

Principle of operation

Peripheral board 2 / 4 evaluates the motor temperature sensed using a PTC thermistor. The board guarantees safety and reliability as a result of the integrated short-circuit detection and sensor cable. Function "Safe torque off" of peripheral boards 3 / 4 and function "ATEX motor temperature monitoring" utilize the same shutdown path:

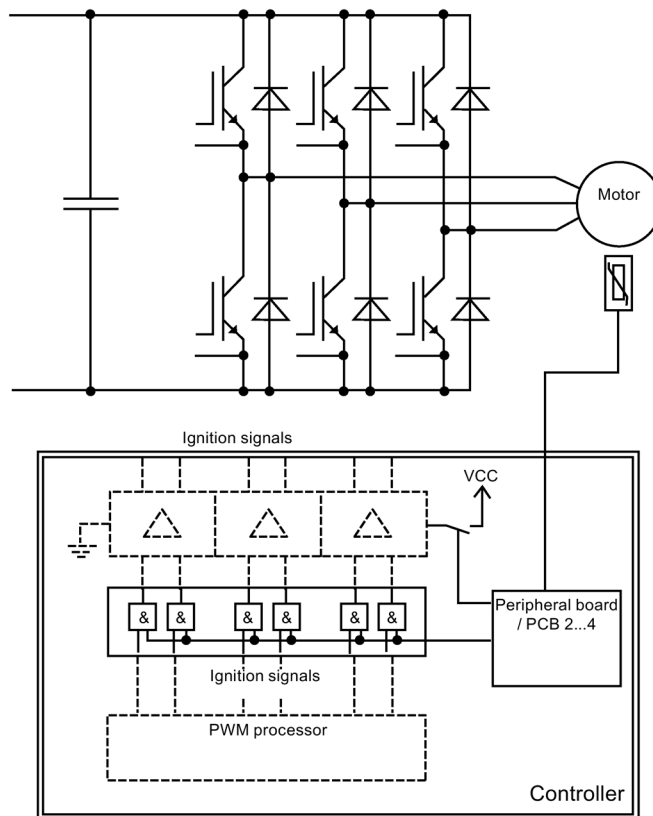

Figure 3-1 Electronic shutdown concept

The inverter control processes the peripheral board signal. In the event of excessive motor temperature, or the function "Safe torque off" response, then the inverter inhibits the firing signals of the IGBTs. The power supply for the driver stages is also switched off. These two switch-off paths ensure that the power infeed to the motor is immediately interrupted. This rules out any additional motor temperature rise or that the motor is operated. You can only reset the inverter or switch it on again if the motor has cooled down sufficiently.

If the power fails, then the inverter safely interrupts the power feed to the motor as firing signals are no longer transferred. If a fault was active at the moment of power failure, the inverter remains in a fault condition, also after power returns.

Risk comparison

In order to rule out possible risks in advance, a risk analysis according to EN 1050 or DIN EN ISO 14121 (draft standard) has been performed for the shutdown path. This analysis concluded that the risk of loss of the shutdown function is small due to the redundant design of the shutdown route and the use of reliable components. However, no general risk assessment was performed as this is usually dependent on many customer-specific parameters. This must be taken into account for the implementation and operation of a system. When compared to shutdown using contactors, only the additional hazard occurs as a result of the risk of dangerous shock currents in the inverter.

Due to the redundant design, it is even achieved that the shutdown is still ensured even if a fault in the electronic shutdown route occurs. As components proven in operation are also used, the inverter is in compliance with DIN EN ISO 13849-1:2015, Category 2, PL c or DIN EN 61508-1:2010, SIL 1.



 **WARNING**

Danger of explosion in the case of deactivated shutdown

In principle, the shutdown function can be deactivated by connecting an appropriate resistor instead of the PTC thermistor to the control cable terminals.

3.3.2.3 Z options with "Safe Torque Off" or ATEX shutdown

Functions "Safe Torque Off" (STO) and ATEX motor temperature monitoring are not integrated in the standard device. The appropriate Z option must be integrated to obtain these functions. You can identify the Z options integrated in a device based on the 3-position extensions of the order number MLFB (+xxx) (see Chapter "Order numbers MLFB / Type designations (Page 31)").

In the subsequent table, you can see which Z options (MLFB extensions) include functions "Safe Torque Off" or ATEX shutdown.

Table 3- 2 Z options with "Safe Torque Off" or ATEX shutdown

Z option MLFB extension (+xxx)	Designation	"Safe torque off"	ATEX shutdown
+G03	PP2 peripheral board	-	X
+G04	PP3 peripheral board	X	-
+G05	PP4 peripheral board	X	X
+G08	PP4 peripheral board in conjunction with package options	X	X
+S01 to +S04 +S08, +S09, +S11, +S12	Application-specific accessory packages, include PP2 peripheral board incl. TMS peripheral board PTC thermistor	-	X
+S31 and +S32	Application-specific accessory packages, include PP4 peripheral board incl. TMS peripheral board PTC thermistor	X	X
+S50 and +S51	Customer-specific accessory packages, include PP4 peripheral board incl. TMS peripheral board PTC thermistor	X	X

3.3.2.4 "Safe torque off" with single circuit trip

The control cable terminals -X2:19, -X2:20 provide a safety-oriented input for safe torque off to DIN EN ISO 13849-1:2015, Category 2, PL c or DIN EN 61508-1:2010, SIL 2. This input safely prevents starting the machine. Use this input, for example for safe shutdown in the case of servicing work on the machine. When using the input, remove the jumper inserted between the control cable terminals -X2:19, -X2:20.

The "Safe torque off" function and the ATEX-certified PTC thermistor input have a redundant switch-off path in the converter. The implementation is performed using hardware. A relay in the power unit of the converter disconnects the power supply of the IGBT driver. A second circuit, also via hardware, produces a controller block. Both switch-off paths are based on the closed-circuit principle, i.e. a failure of the control voltage results in redundant shutdown of the converter.

 **WARNING**

Electric shock

If you carry out maintenance or overhaul work on the converter without safely disconnecting the power supply, serious injury or death due to electric shock can occur. The input for "Safe torque off" is not an Emergency Off input which safely disconnects the converter or the motor from the mains power supply.

Safely and reliably disconnect the power supply before opening covers or terminal boxes at the converter. For example, use a main switch.

3.3.2.5 "Safe torque off" with two circuit version

In the inverter, you can also initiate the "Safe torque off" function using two safety circuits. You must connect one circuit as NC contact at terminals -X2:19/:20 (just the same as for a single-circuit trip). You must connect the second circuit as NC contact at terminals -X2:24/:3.

In the 2-circuit version, "Safe torque off" complies with requirements according to DIN EN ISO 13849-1:2015, Category 3, PL d or DIN EN 61508-1:2010 SIL 2

NOTICE

Malfunctions

Carefully ensure that the "Safe torque off" function in the inverter is configured for a two-circuit trip.

3.3.2.6 Switchover, single circuit <-> two circuit tripping

The safety-related "Safe torque off" function in the inverter is purely based on a hardware-related shutdown of the power section. The corresponding input circuits only act on the two shutdown paths in the inverter via the hardware circuit.

NOTICE

Bail switch S3

Just bail switch S3 on peripheral board DI/DO determines whether the "Safe torque off" function is initiated through one or two channels.

The software is not relevant for the safety analysis. It only serves to provide display and information relating to the "Safe torque off" function. However, in order to commission the inverter, you must appropriately set parameter "P-INVERTER DATA/STO".

Bail switch S3 on peripheral board DI/DO

With the bail switch, you define as to whether in addition the second shutdown circuit should be activated at terminal X2:24 - or not.

Bail switch S3 open:

single-circuit trip, only via X2:19/:20

Bail switch S3 closed:

two-circuit trip, additionally via X2:24/:3

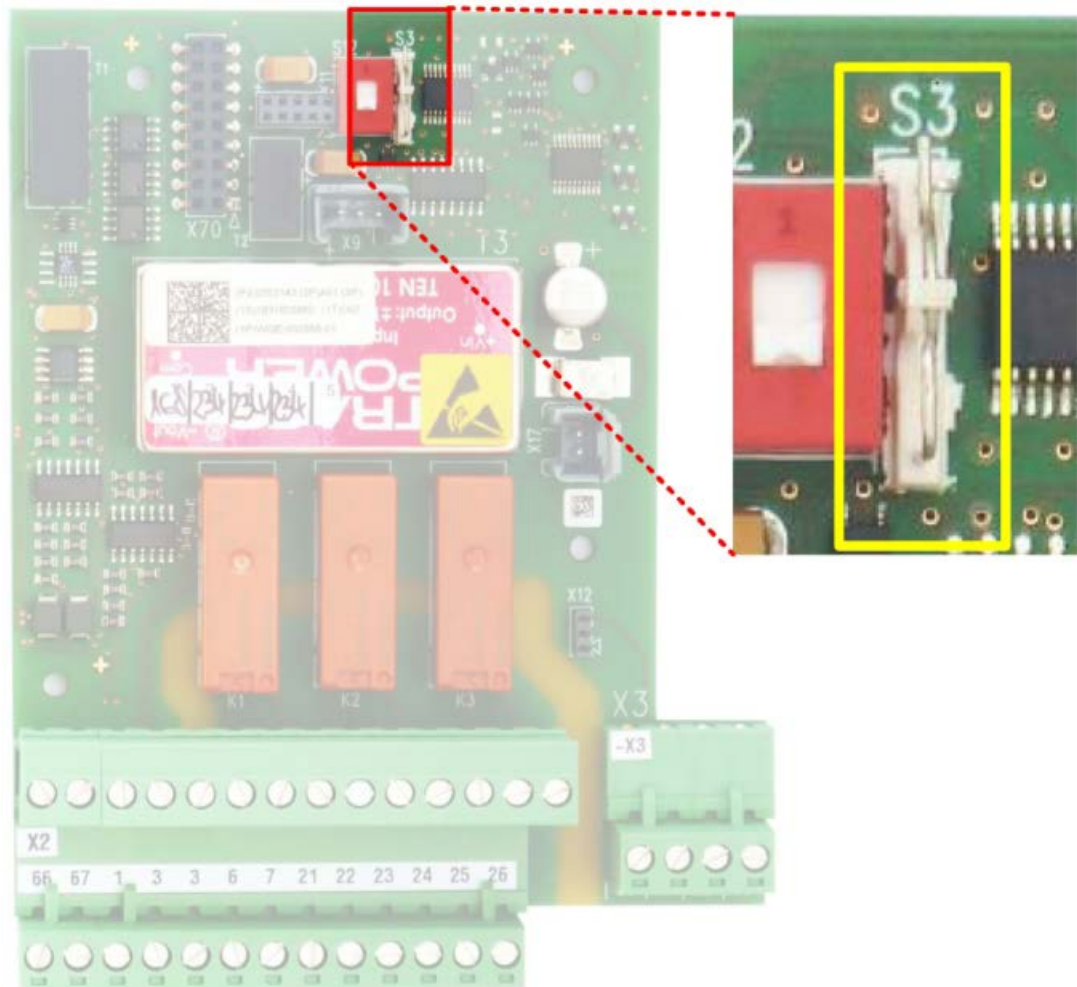

Figure 3-2 Position of the bail switch S3 on peripheral board DI/DO

Parameter "P-INVERTER DATA/STO"

Using this parameter, you tell the inverter software as to whether you are using using the "Safe torque off" function with single-circuit or two-circuit trip. The parameter is not relevant for the actual safety-related shutdown via the two shutdown paths in the inverter.

Parameter "STO = X2:20":

single-circuit trip, only via X2:19/:20

Parameter "STO = X2:20/24":

two-circuit trip, additionally via X2:24/:3

3.3.2.7 Checking the "Safe halt" function

Procedure

Test the shutdown function for the operation of the "Safe torque off" function. Proceed as follows:

1. Check the setting of the bail switch S3 on peripheral board DI/DO:
 - open: for single-circuit trip
 - closed: for two-circuit trip
2. Connect power to the converter.
3. Check parameter "P-CONVERTER DATA/STO":
 - "X2:20": for single-circuit trip
 - "X2:20/24": for two-circuit trip
4. It is advantageous if you track the "Status" converter actual value. You can either do this in the display, if you parameterize this actual value temporarily in the 4th status line or in the IMS, if you are connected with a PC.
5. If required, enter the necessary switch-on commands so that the converter is at least in the ready state, i.e. "status = Rdy.f.work".
The "READY" LED is lit.
6. (Simultaneously) open the safety circuit(s), that is/are connected as follows:
 - For single-circuit trip at -X2:19/:20.
 - For a two-circuit trip, additionally at -X2:24/:3.The converter switches into the "Switch interlock" status, the "READY" LED goes dark. The "Safe torque off" "active" message is displayed.
7. Attempt to exit the state by pressing "RESET".
It is not permissible that the converter exits the "Switch interlock" state. The message "Safe torque off" "active" must remain active.
8. Connect the safety circuit(s) at -X2:19/:20 and possibly at -X2:24/:3.
The converter initially stays in the "Switch interlock" state; however, the display changes to "!! OFF2 !!" "After STO act.".

9. Depending on the setting of parameter "P-CONVERTER DATA/P-Monitoring/STO" to:
 - "Store"

The converter remains in the "Switch interlock" state with the display "!! OFF 2 !!" "After STO act.". Press "RESET" of the converter. The converter exits the "Switch interlock" state.
 - "Auto.reset"

The converter automatically exits the "Switch interlock" state. The converter starts to test both shutdown paths, "Test safe torque off" "running" is displayed - assuming that the required conditions are satisfied. This means that terminal -X2:8 must be controlled - and if a line contactor is being used - this line contactor must be closed. If the required conditions are still not available, then the converter waits until the appropriate conditions are available, then performs the test before the converter is switched on. The test takes several seconds.
10. If the test is successfully completed, then the converter is again in the initial state. If the test results in a fault, then the converter changes into the "Fault" status. The "FAULT" LED lights up, and the display changes to "!! Converter fault !!" "Test safe torque off". In this case, it is crucial that you contact the factory.

Additional test if you use a single-circuit trip:

11. Open terminal input -X2:24 if a signal is connected. The converter either does not display a response, or it may only display a response that is parameterized for input -X2:24, independent of the "Safe torque off" function. It is not permissible that it changes into the "Fault" state with the following displays:
 - "!! Fault !!" "Safe torque off trig".
 - "!! Converter !!" "Test safe torque off".
 - "!! Fault !!" "S7 inactive".

In cases such as these, check the setting. Either switch S3 and/or the parameters are set to the two-circuit trip.

Additional test if you use a two-circuit trip:

12. Only open the safety circuit at -X2:24/:3. The converter changes into the "Fault" state. The "FAULT" LED lights up. The display changes to "!! Fault !!" "Safe torque off trig".
13. Reconnect the safety circuit to -X2:24/:3 and acknowledge the fault. The converter tests the shutdown paths according to step 9. and 10.
14. Only open the safety circuit at -X2:19/:20. The converter changes into the "Fault" state. The "FAULT" LED lights up. The display changes to "!! Fault !!" "Safe torque off trig".
15. Reconnect the safety circuit at -X2:19/:20 and acknowledge the fault. The converter changes into the "Switch interlock" state. The converter displays message "!! OFF 2 !!" "After STO act.".
16. Depending on parameter "P-CONVERTER DATA/P-Monitoring/STO", you must acknowledge again. See Step 9.
17. The converter tests the shutdown paths according to step 9. and 10.

Resolving problems

For an incorrect setting at the bail switch S3 on Peripheral board DI/DO and/or parameter "P-CONVERTER DATA/STO" result in the following different responses. Recheck the settings.

Test step	Different response	Incorrect setting
12	The converter either displays no response - or just that response that is parameterized for input -X2:24, independent of the "Safe torque off" function.	You have neither set switch S3 nor the parameter to the two-circuit trip.
	The converter changes into state "Fault" with display "!! Fault !!" "S7 inactive"	You have set switch S3 to the two-circuit trip and the parameter to single-circuit trip ("X2:20").
	The converter changes into state "Fault" with display "!! Converter fault !!" "Test safe torque off".	You have set switch S3 to the single-circuit trip and the parameter to two-circuit trip ("X2:20/24").
14	The converter changes into the "Switch interlock" state, the "READY" LED goes dark. The "Safe torque off" "active" message is displayed on the converter display.	You have either only set the parameter or simultaneously also switch S3 to the single-circuit trip.

For all additional deviations when checking the "Safe torque off" function, it is crucial that you contact a service station or the factory.

Note

The converter tests the two shutdown paths:

- After the "Safe torque off" function is tripped.
- After acknowledging the fault "!! Converter fault !!" "Test safe torque off".
- After acknowledging the ATEX motor temperature monitoring "!! Fault !!" "Thermistor X3:90/91".
- Each time the control voltage is switched on (supply for the various boards).
- If the test is initiated using parameter "P-EXTRAS/Test STO/PTC".

3.3.2.8 PTC inputs for motor PTC thermistor

The peripheral boards 2 / 4 provide two PTC thermistor inputs at the control cable terminals -X3:90-93 for the motor temperature monitoring. When using the inputs, remove the 100 Ω resistor connected there.

Peripheral board 1 and peripheral board 3 have control cable terminals for the PTC inputs. However, there is no evaluation board. No monitoring is made if you connect PTC thermistors.

Test the PTC thermistors as described below. Consult the factory if the shutdown does not function.

Inverters without a peripheral board provide PTC thermistor inputs at control cable terminals -X2:27-28. If the peripheral board 2 or 4 is fitted, connect the PTC thermistors of the motor to control cable terminal -X3.

This has the following advantages:

- Sensor short-circuit monitoring
- Protective separation of the PTC thermistor inputs from all other inputs up to a rated voltage of 690 V. The control cable terminals -X2:27/28 provide protective separation from the electronics, but no separation from the other inputs.
- Input -X3:90-91 is ATEX-certified according to PTB 07 ATEX 3057 for motors located in hazardous zones.
- Redundant shutdown route, realized using hardware.

Checking the PTC thermistor shutdown function

Test the shutdown function before commissioning the board. Proceed as follows:

1. Replace the 100 Ω resistor at the control cable terminals -X3:90/91 by a potentiometer with at least 10 k Ω . Set a value of approx. 100 Ω .
2. Ensure that 24 V is applied at control cable terminal -X2:8. When required, jumper -X2:8 and -X2:3.
3. Connect power to the inverter so that the "READY" LED on the display lights up.
4. Increase the resistance at the potentiometer. The inverter must go to "FAULT" at the latest for "3,8 k Ω ":
 - LED "READY" goes dark.
 - The red "FAULT" LED is lit.
 - The inverter display shows fault message "!! Fault !! PTC thermistor -X3:90/91".
5. At this instant in time, it is not permissible that the inverter is switched on by pressing the <On> key on the display.
6. Acknowledge the error, e.g. using the <S+I> buttons on the display. When acknowledging, the inverter checks the two redundant shutdown paths.
 - If, after acknowledgment, the inverter returns to "READY" and a fault is no longer displayed, then the test has been successfully completed.
 - If the inverter remains at "FAULT", and the following is shown in the display "!! Inverter fault !! Test PTC -X3:90/91" then one of the shutdown paths is not functioning correctly. In this case, please contact the factory.
7. If the inverter is ready again, then rotate the potentiometer towards 0 Ω . At the latest at a resistance of 15 Ω the short-circuit monitoring of the sensor circuit responds. Follow the description under points four and five.
8. The safety function is checked automatically when the inverter control voltage returns and when the fault is acknowledged after a test.

3.3.3 Brake transistor and brake resistor

During motor operation the electrical power flow is from the inverter to the motor. During generator operation the electrical power flow is from the motor to the inverter.

Example: braking flywheels.

The DC link current reverses the direction. The standard version of the inverter cannot feed energy back into the system. Kinetic energy can be converted into dissipated heat in braking operation. Approx. 10% braking torque is available in the upper speed range. A braking torque of up to 50% without additional equipment is achieved in the medium and lower speed ranges by oversaturation of the motor. With the brake transistor accessory, the same braking as driving torque is available. The energy occurring is converted to heat using a pulsed transistor. Also connect an external brake resistor.

 WARNING
Risk of fire If the clearance between the resistors and the neighboring components is selected too small, fire can occur due to overheating. This can result in death, serious injury or material damage. <ul style="list-style-type: none">• Maintain a minimum clearance of 200 mm.

3.3.3.1 Dimensioning the brake resistor

Select a resistance value of at least that stated in the technical data. This value corresponds to the minimum value that can be set.

The maximum value is calculated from the following equation:

$$R = (1.57 \times U_{\text{mains}})^2 / P_{\text{brake}}$$

3.3.3.2 Connecting the brake resistor

1. Using the device designation on the rating plate of the device, check whether you have a device with the "brake resistor" option. The designation must be ...2T..-.....-...B....

For more detailed information about the designation, refer to Chapter "Order numbers MLFB / Type designations (Page 31)".

2. Connect the external braking resistor at terminals -X1:R and -X1:UD2+.
3. Use shielded cables with concentric protective conductor or shielded cables to connect the brake resistor. Connect the shield where the cable enters the inverter.

4. Set parameter "P-INVERTER DATA/Brake" to "On".
5. Set the rated resistor power under "/P-BrakeRes." and the resistance value under "/R-BrakeRes.". In this way, you prevent overloading of the resistor.



Incorrect parameter settings

If you parameterize the resistance data incorrectly, you can destroy the brake transistor or the brake resistor which can result in injury to personnel.

- Input the correct data in the inverter.

Install the resistors so that the perforated plate is on the bottom, top and the front sides. The connection box can be provided on the left or the right side.

If you require several resistors for series or parallel connection, install the resistors next to each other. This also applies for wall mounting.

3.3.4 Parameter overview

A more detailed overview of all parameters can be found in the "IMS" software or in the parameterization guide. You can find both on the Internet (<http://www.siemens.com>).

3.3.5 "Factory settings" application

Saved device settings which have been made during the internal factory device inspection can be found in this application. For example, these can be special data for the motor or also a complete parameter configuration.

3.3.6 Protective cover IP21 for compact and compact Plus devices

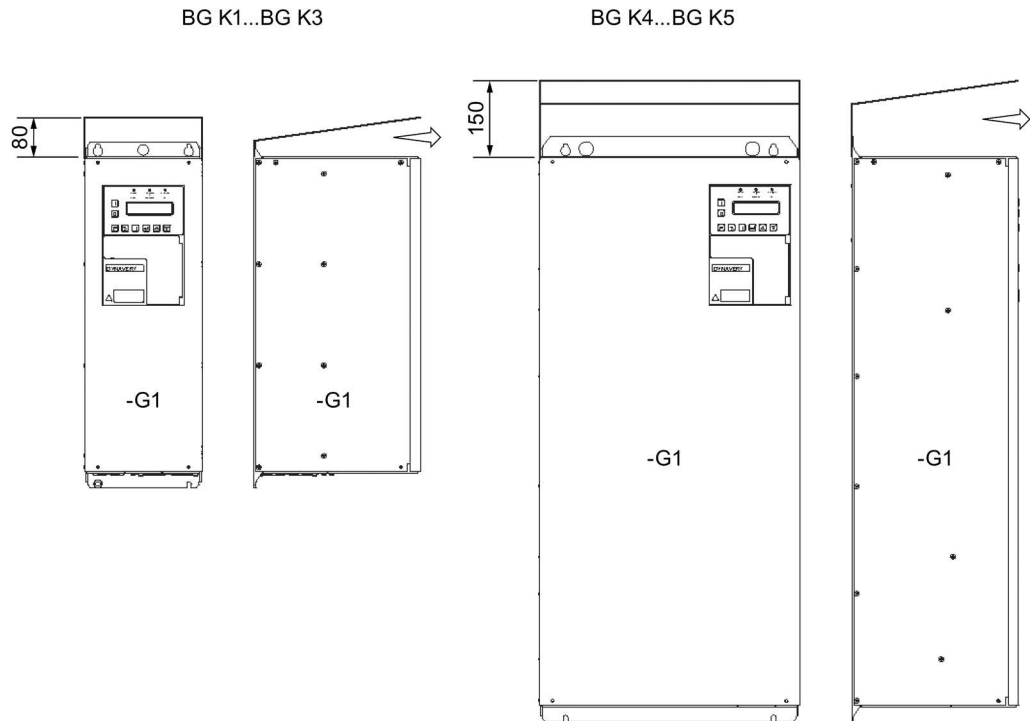

Figure 3-3 Canopy IP21

All compact units have degree of protection IP20. The canopy with degree of protection IP21 is available as an accessory for all compact and compact Plus units. The canopy is 5 mm wider on both sides than the inverter. Take account of this clearance for the alignment. Leave the outlet area at the front clear.

Proceed as follows to install the canopy supplied loose:

1. Screw the inverter without canopy onto a mounting plate. Do not tighten the top two mounting screws completely.
2. Slide the cover under the not yet completely tightened mounting screws.
3. Tighten the mounting screws completely.

With degree of protection IP21, the type code changes from 2T2A.....-... to 2T3A.....-... .

3.3.7 Main switch "Q 2T..." or "W 2T..."

Inverters can optionally be purchased with a main switch as switch disconnecter. The manual operation of the switch is on the inside for the "W" version. The switch is strictly a maintenance switch. The switch can only be operated when the corresponding covers for compact units or doors for cabinet units are opened.

The switch can be manually operated from the outside for the "Q" version. The handle can be blocked in the zero position with up to three padlocks. The switch is thus protected against being switched on again. The padlocks are not included in the delivery.

For this option, the following dimensions are produced for the individual frame sizes:

Table 3- 3 Main switch option for different frame sizes

BG K1 ... BG K4	Standard device dimensions only
BG K5	Option "Q" / "W" is not possible.
BG K51	For this frame size you can integrate option "Q" / "W".
BG K6	In this case, option "Q" / "W" is only possible in a cabinet system 2X....
BG K6 BG S1 ... BG S3	No different dimensions than standard device

 CAUTION
<p>Serious injury and material damage caused by arcs</p> <p>If the mains power supply cable is not properly connected to the main switch for the "Q" / "W" option, destruction due to arcs can occur.</p> <ul style="list-style-type: none"> • Connect the mains power supply line to the main switch properly. • Follow the connection instructions supplied by the manufacturer of the main switch. The instructions can be found in the unit or inside the door in the cabinet pocket.

3.3.8 DC link terminals for compact devices

Features

DC link terminals –X1:UD+2 and –X1:UD-2 are always available for the small inverters up to 2T2A07400-030 for 400 V or up to 2T2A07500-037 for 500 V. These can be optionally purchased for all larger inverters. The inverters have to be connected using the DC link if you want to establish a DC group. Only implement a DC group if you want to operate one drive in the generator mode.

Example: Test station with load apparatus. In this case only the losses are supplied via the network. The generated energy is routed via the DC link. Refer to the following graphic for the electrical design:

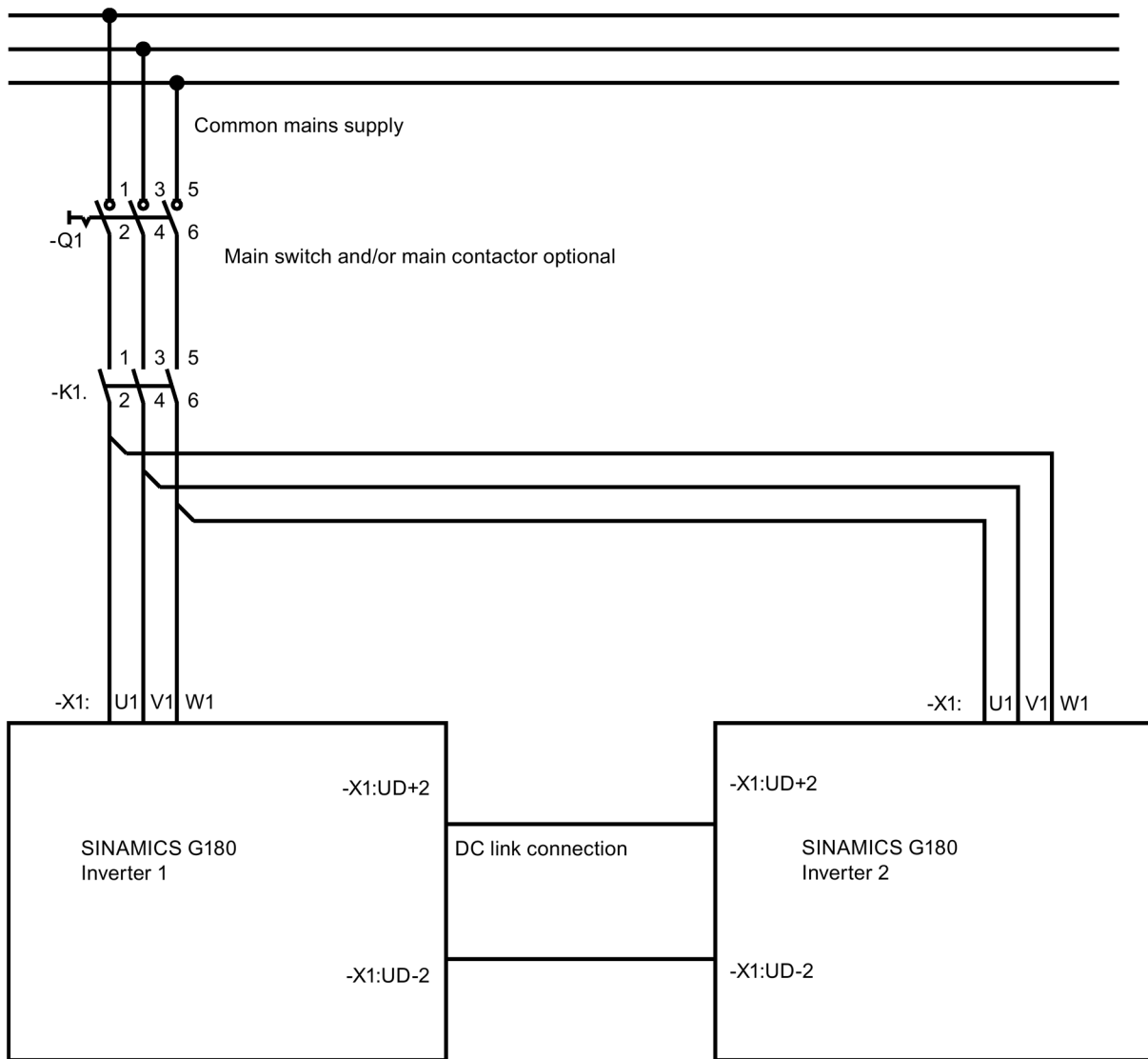

Figure 3-4 DC group

Please observe the following:

- Inverter 1 and Inverter 2 must be the same type.
- Connect both inverters to the line supply using a common infeed.
- Operate the line infeed current of each inverter at maximum 75 % of the rated current.
- The line supply connecting cables from -K1:2, 4, 6 to both inverters must be the same length and have the same cross-section.
- You can use a normal cable to connect the DC link, e.g. H07VK in the cabinet, or NYY outside the cabinet.

- Design the cross section according to the current load.
 - DC link current = 1.3xmains current.
 - Lay both lines parallel with as small as possible distance from each other.
 - Bind the H07VK cables together using cable ties.
- For both inverters, set parameter "P-INVERTER DATA/Brake" from "Off" to "R-Supply".
 - Use a braking device if the complete drive for braking flywheels can operate as generator for both inverters.
 - In this case, parameterize the inverter with braking resistor to "On".

NOTICE
Destruction of the inverter
If you use one of the following configurations without first consulting the factory, then the inverter could be destroyed:
<ul style="list-style-type: none">• Two different inverters• More than two inverters• More than 75% mains power feed• Only one mains power connection.• DC network for cabinet units.
Check the design with DC network exactly. Consult the factory for this.

3.3.9 External display

An external display can optionally be connected. The external display with the item number L0296033 has the same functionality as the internal display.

Additional information is provided in Chapters "Connection for optional external display with RS 485 (Page 155)" and "Installing an external display (Page 88)".

3.3.10 RFI suppression filter, category C1 (class B)

If necessary, use an RFI suppression filter, category C1 (class B), in the inverters. More detailed information is provided in Chapter "EMC (Page 75)".

From the unit designation you can identify whether you have a unit with the option RFI suppression filter category C1 (class B). In this case, the rating plate is stamped as follows ".2...-.....-....B....".

More detailed information is provided in Chapter "Order numbers MLFB / Type designations (Page 31)".

The dimensions are unchanged for compact devices. The dimensions of cabinet units increase if an RFI suppression filter category C1 (class B) is installed. Additional data is provided in the unit documentation.

3.3.11 Strengthened du/dt filter

A strengthened du/dt filter is available as an option.

See also

Dimensioning maximum motor cable length (Page 99)

3.3.12 Sine-wave filter

Note the following information when using a sine-wave filter

A sine-wave filter is available as an option for the motor power supply.

It must be noted that sine-wave filters are only designed for the nominal clock frequency. Therefore, parameter "f-pulse min" under "P-MACHINE POWER CONV/P-MSC data" must always be set to the rated clock frequency!

NOTICE
Overheating of the sine-wave filter
If the clock frequency drops to below the nominal clock frequency of the sine-wave filter, the filter can overheat. The equipment will be damaged as a result.
<ul style="list-style-type: none">Always set parameter "f-pulse min" under "P-MACHINE POWER CONV/P-MSC data" to the rated clock frequency!

3.3.13 Additional mains power protection chokes

You can expand an inverter to include an additional line protection choke. Use an additional choke if the input side mains power shows a large unbalanced load due to different voltage on L1, L2 and L3 or if the mains power or if the mains power already has harmonics. In this case, please contact the Service Center.

3.3.14 Optional fieldbus connection

3.3.14.1 PROFIBUS DP

You can purchase a PROFIBUS board as accessory. The PROFIBUS board is installed under the grey plastic cover. The board can be retrofitted. You recognize from the description "... Type code ____ P_" on the rating plate that a PROFIBUS board has been integrated.

More details about the board and the PROFIBUS parameters can be found in the separate PROFIBUS description.

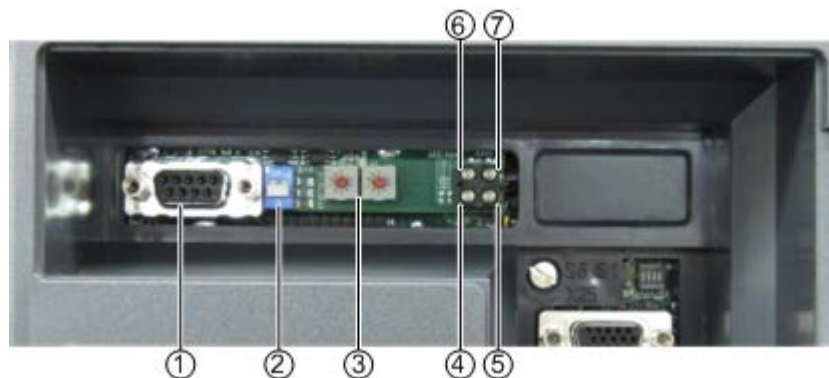

- ① PROFIBUS connection
- ② Switch for terminating resistor
- ③ PROFIBUS address, settable
- ④ LED "bus diagnostics"
- ⑤ LED "Offline"
- ⑥ Unused LED
- ⑦ LED "Online"

Figure 3-5 PROFIBUS board

Table 3- 4 PROFIBUS board - external elements

Component	Function	
LED "Status" (only just visible under the grey cover)	Flashing red at different frequencies	Hardware fault on the PROFIBUS board: Contact the service department.
	Flashing green at 1 Hz, 0.5 s on, 0.5 s off	PROFIBUS board initialization OK
	Flashing green at 2 Hz, 0.25 s on, 0.25 s off	Error when initializing the PROFIBUS board: Contact the service department.
LED "Online"	This green LED lights if the bus connection is OK.	
LED "Offline"	This red LED lights if the bus connection is interrupted. Check the external bus configuration.	
PROFIBUS connection	Sub-D socket for PROFIBUS	
Switch for terminating resistor	A bus line must be terminated with a terminating resistor. Note that a terminating resistor can also be installed in the plug and select the switch position accordingly. Switch up = resistor On. Only one terminating resistor is permitted at the end of a PROFIBUS line.	

Component	Function	
Settable PROFIBUS address	The PROFIBUS address is set using the software as follows: The value 0 ... 125 can be set under "P-INTERFACE/P-fieldbus/P-PB/PN/Modbus/P-Profibus/BUS address". If you enter a value of 0, then the address is set using the hardware. In this case, set an address in the range 0 to 99 using a screwdriver.	
LED "bus diagnostics"	Flashing at 1 Hz, 0.5 s On, 0.5 s Off	Error in the input/output configuration
	Flashing at 2 Hz, 0.25 s On, 0.25 s Off	Error in the length of the PROFIBUS telegram
	Flashing at 4 Hz, 0.12 s On, 0.12 s Off	Error when initializing PROFIBUS
	Off	No bus fault

3.3.14.2 PROFINET IO

You can purchase a PROFINET board as accessory; it can also be retrofitted. This is installed under the grey plastic cover. It is available in two versions: with Ethernet or alternatively with fiber optic sockets.

Based on the designation on the rating plate, you can identify whether or which of these two boards is installed.

The designation

"... Type code _____ N _" means Ethernet CU (RJ45) connection and

"... Type code _____ F _" means fiber optic (SCRJ) connection

(see: Order numbers MLFB / Type designations (Page 31))

Note

Risk of confusion relating to the LEDs

The "Network status" display (NS), as well as the "Module status" display (MS) comprises a green and a red LED.

The "Link / Activity / Speed" (L/A/S) display comprises a green and a yellow LED.

In the following, the term "LED" summarizes the two LEDs in the display mentioned in the corresponding context.

As the two LEDs are close to one another, there is a risk of confusion, especially for the network status and module status LEDs.

PROFINET board with CU connection - RJ45 connector, option code: N

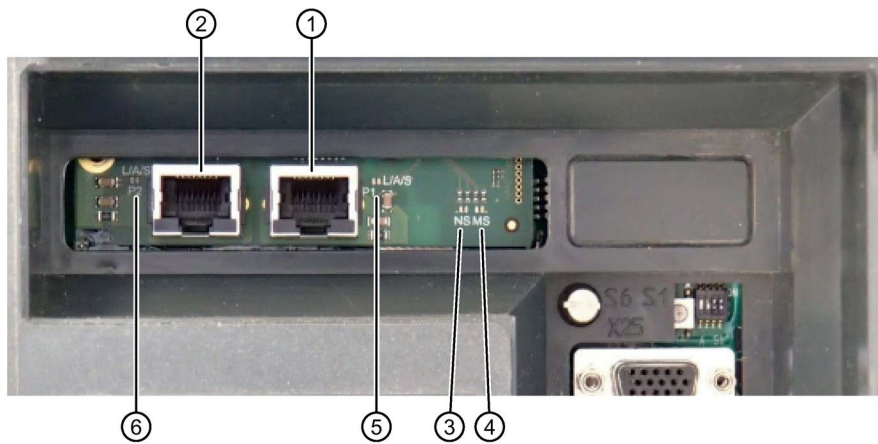

- ① Ethernet RJ45 socket: Port 1
- ② Ethernet RJ45 socket: Port 2
- ③ NS: "Network status" display
- ④ MS: "Module status" display
- ⑤ L/A/S: "Link / Activity / Speed" display: Port 1
- ⑥ L/A/S: "Link / Activity / Speed" display: Port 2

Figure 3-6 PROFINET board: Version with Ethernet sockets

PROFINET board with FO connection - SCRJ connector, option code: F

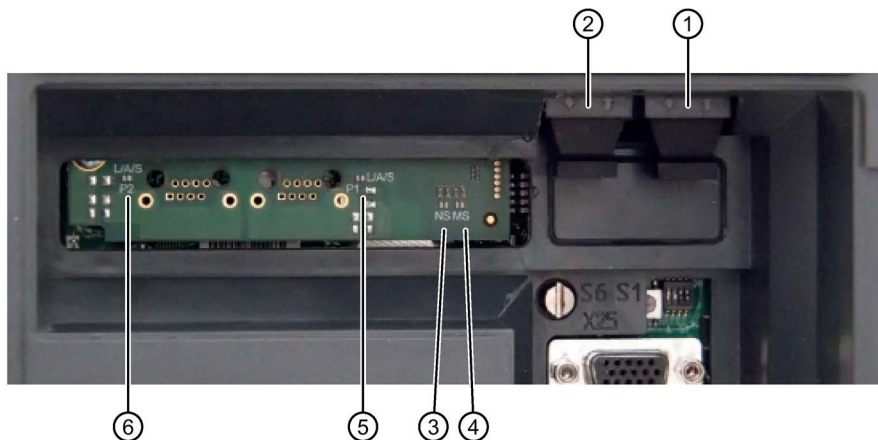

- ① SCRJ fiber optic socket: Port 1
- ② SCRJ fiber optic socket: Port 2
- ③ NS: "Network status" display
- ④ MS: "Module status" display
- ⑤ L/A/S: "Link / Activity / Speed" display: Port 1
- ⑥ L/A/S: "Link / Activity / Speed" display: Port 2

Figure 3-7 PROFINET board: Version with fiber optic sockets

Note

Suitable fiber types

HCS as well as APF cables (POF) are suitable for connecting to the fiber optic sockets.

Typical cable lengths are up to 100 m (HCS) or up to 50 m (POF).

Table 3- 5 PROFINET board - external elements

Component	Function		
NS "Network status" display	Off	Offline	No power supply or no connection with the IO controller
	Green, lit	Online (status: RUN)	Connection established with the IO controller, IO controller in the RUN state
	Flashing green (1 Hz)	Online (status: STOP)	Connection established with the IO controller, IO controller in the STOP state or IO data error
	Flashing green (3x at 1 Hz)	Flashing	Flashes three times in order to identify the slave in the network.
	Red, lit	Fatal event	Critical, internal error This display occurs in conjunction with a red "Module status" LED.
	Flashing red (1 Hz)	Error, station name	A station name has not been assigned (factory setting).
	Flashing red (2 Hz)	Error, IP address	An IP address has not been assigned (factory setting).
	Flashing red (3 Hz)	Error, configuration	The reference configuration (expected identification) differs from the actual configuration (real identification) of the system.
MS "Module status" display	Off	Not initialized	No power supply voltage or module in the SETUP or NW_INIT state
	Green, lit	Normal operating sequence	The module has exited the NW_INIT state.
	Flashing green (1 Hz)	Diagnostic event(s)	At least one diagnostics event is active.
	Red, lit	Exception error	Device in the EXCEPTION state
		Fatal event	Fatal internal event. This display occurs in conjunction with a red "Network status" LED.
Flashes red/green alternating	Firmware update	Do not switch off the module. Switching off the module during the update can result in permanent damage.	

Component	Function		
L/A/S "Link / Activity / Speed" display (port 1 + port 2)	Off	No connection	No communication
	Green, lit	Connection with 100 Mbit	Ethernet connection established, but no communication.
	Green, flickering	Activity with 100 Mbit	Ethernet connection established and active communication.
	Yellow, lit	Connection with 10 Mbit	Ethernet connection established, but no communication.
	Yellow, flickering	Activity with 10 Mbit	Ethernet connection established and active communication.

3.3.14.3 Modbus RTU

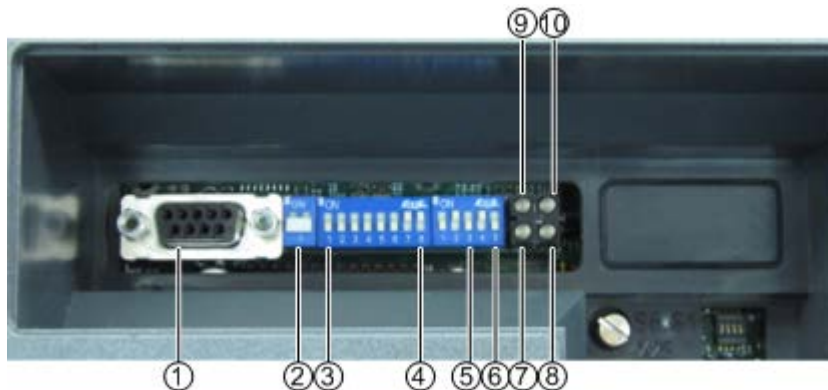

You can purchase a Modbus board as an accessory. The Modbus board is installed under the plastic cover. The board can be retrofitted. You recognize from the description "... *Type code* ____ M _" on the rating plate that a Modbus board has been integrated.



- ① Modbus connection
- ② Switch for terminating resistor
- ③ DIL switches 1 ... 7: Modbus address, configurable
- ④ DIL switches 8, 1, 2: baud rate, configurable
- ⑤ DIL switches 3, 4: parity, configurable
- ⑥ DIL switch 5: interface type, configurable
- ⑦ LED "Status Hardware Settings"
- ⑧ LED "Bus ready"
- ⑨ LED "Processing"
- ⑩ LED "Bus error"

Figure 3-8 Modbus board

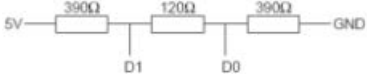
Table 3- 6 Modbus board - external elements

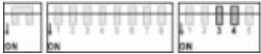
Component	Function	
LED "Status Hardware Settings"	Red, lit	DIL switches are set to "not active" status (all set to "off" or impermissible values)
	Green, lit	DIL switch settings changed by software.
	OFF	DIL switch settings are used and are OK.
LED "Bus ready"	Green, lit	bus OK, normal operation
	Red, lit	Bus error, timeout
	OFF	Board has not been correctly initialized
LED "Processing"	Flashing green	Board receives a request and produces a response
	OFF	Board is not currently processing any requests
LED "Bus error"	Red, lit	Bus error
	OFF	Normal operation or circuit board not initialized
Modbus connection	Sub-D female connector for Modbus	
Switch for terminating resistor	<p>A bus line must be terminated with a terminating resistor. A terminating resistor can be fitted in the connector. Select the switch position accordingly. Switch up = resistor On</p> 	
Available Modbus addresses	<p>You can set the Modbus address using the software as follows: A value of 0 ... 247 can be set under "P- INTERFACE/P-fieldbus/P-PB/PN/Modbus/P-Modbus RTU/BUS address". If you enter a value of 0, then the address is set using the hardware. In this case, set a binary address from 1 to 127 with the DIL switches. (Switch 1 is MSB, switch 7 is LSB)</p> 	
Configurable baud rate	<p>You can set the baud rate using the software under "P- INTERFACE/P-fieldbus/P-PB/PN/Modbus/P-Modbus RTU/baud rate". If you enter a value of 0 under "P-INTERFACE/P-fieldbus/P-PB/PN/Modbus/P-Modbus RTU/BUS address" then the baud rate is set using the hardware. Set the binary baud rate according to the following list:</p> <ul style="list-style-type: none"> • 000: not available • 001: 1200 • 010: 2400 • 011: 4800 • 100: 9600 • 101: 19,200 (standard for RTU) • 110: 38,400 • 111: 57,600 	
Configurable parity	<p>You can set the parity using the software under "P- INTERFACE/P-fieldbus/P-PB/PN/Modbus/P-Modbus RTU/parity". If you enter a value of 0 under "P-INTERFACE/P-fieldbus/P-PB/PN/Modbus/P-Modbus RTU/BUS address" then the parity is set using the hardware. Set the binary parity according to the following list:</p> <ul style="list-style-type: none"> • 00: not available • 01: none (standard for RTU) • 10: even • 11: odd 	

Component	Function	
Configurable interface type 	Set this switch according to the interface you want to use. <ul style="list-style-type: none"> 0: RS 485 1: RS 232 	
LED "Status" (above the DIL switches, only visible if the blue cover is removed)	Flashing red at different frequencies	Hardware error on the Modbus board: Contact the service department.
	Flashing green at 1 Hz, 0.5 s on, 0.5 s off	Initialization of the Modbus board OK
	Flashing green at 2 Hz, 0.25 s on, 0.25 s off	Initialization of the Modbus board has errors: Contact the service department.

Table 3- 7 Pin assignment of the Modbus connection with Sub-D connector

Pin	Designation	Function
Enclosure	Shield	Cable shield
1	-	Not used
2	RS 232 - TX	Signal (transmit)
3	RS 232 - RX	Signal (receive)
4	-	Not used
5	GND	Signal ground
6	+ 5 V	Supply voltage
7	RS 485 D0	-
8	RS 485 D1	-
9	-	Not used

Modbus connection Sub-D

3.3.14.4 Modbus TCP

You can purchase a Modbus TCP board as an accessory. The Modbus board is installed under the plastic cover. The board can be retrofitted. You recognize from the description "... Type code ____T_" on the rating plate that a Modbus TCP board has been integrated.



Figure 3-9 Modbus TCP board

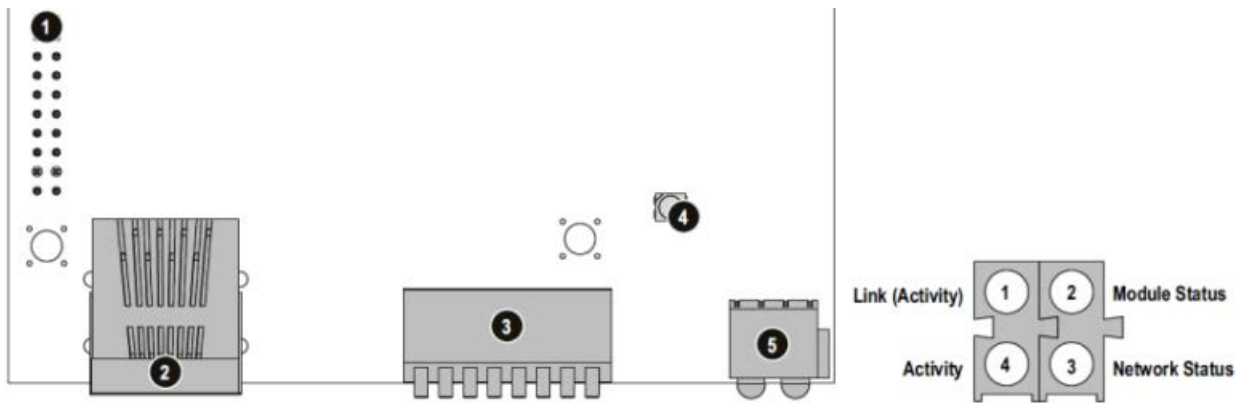

- (1) Internal bus connection
- (2) Ethernet connection socket RJ45
- (3) Configuration switch
- (4) Anybus Watchdog
- (5) Status LEDs

Figure 3-10 Modbus TCP board

Description

3.3 Accessories

Table 3- 8 Modbus TCP board - external elements

Component	Function	
LED 1 "Link (Activity)"	Off	No connection found
	Green, lit	Connection found
LED 2 "Module Status"	Off	No power supply
	Flashing green (1 Hz)	IP address not set via the configuration switch
	Flashing red (1 Hz)	Invalid MAC address (internal error)
	Flashing red (2 Hz)	Ethernet configuration was not able to be loaded from the FLASH
	Flashing red (4 Hz)	Internal error (fatal)
	Red	Already assigned IP address found
LED 3 "Network Status"	Flashes n times	The number of flashing signals of this LED corresponds to the number of existing Modbus/TCP connections
LED 4 "Activity"	Flashing green	Data is being received or sent
Modbus connection	Ethernet connection socket RJ45	
Configuration switch	<p>You can make the TCP/IP settings using the software as follows: IP address under "P-INTERFACE/P-fieldbus/P-PB/PN/Modbus/P-Modbus TCP/IP" sub net under "P-INTERFACE/P-Fieldbus/P-PB/PN/Modbus/P-Modbus TCP/SN" gateway under "P-INTERFACE/P-Fieldbus/P-PB/PN/Modbus/P-Modbus TCP/GW" If you enter a value 0-0-0-0 for the IP address, then the following default values are used, the IP address is completed using the hardware: IP address: 192.168.0.x (x = value at the configuration switch) Gateway: 0.0.0.0 Subnet: 255.255.255.0 The last byte of the IP address is set (binary) at the configuration switch. The IP address set in the example of the diagram on the left is: 192.168.0.42</p>	

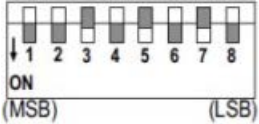

Ethernet

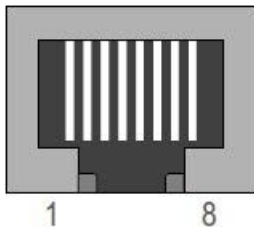

Figure 3-11 RJ45 standard connection socket

Table 3- 9 RJ45 pin assignment

Pin	Signal	Remark
1	TD+	-
2	TD-	-
3	RD+	-
4	-	Normally not used; in order to prevent falsification of the signals, these pins are connected with one another and connected via a filter circuit on the module with PE.
5	-	
6	RD-	-
7	-	Normally not used; in order to prevent falsification of the signals, these pins are connected with one another and connected via a filter circuit on the module with PE.
8	-	

3.3.15 Pre-switch mode power supply 300 W

General information

The pre-switch mode power supply is used to supply switch-mode power supplies and fans from the DC link of converters or a comparable PC source (e.g.: UPS) The power supply can be used to buffer the line supply for a short period of time.

Designation Material number	PC board pre-switch mode power supply 300W L0329237 (main PC board with small mounted PC board L0329239)
Inputs Rated input voltage UD+/UD-	250 ... 1300 V DC (switched on above 150 V, switched off < 100 V and > 1500 V)
External supply -X1	230 V AC (is switched-on, if 300 V DC < 250 V, switched off for > 270 V)
Control voltage, fan -X32	Controlling the fan voltage X11 with 0 V/15 V/24 V (10 ... 15 ... 19 V > 12 V, 20 ... 24 ... 30 V ... > 24 V)
Outputs SNT 300 V X4 fan 24 V	300 V ± 25 V/1 A/300 W (basic insulation) 24 V ± 2 V/8 A/192 W (protective separation) X11:1, 2: fan (0 V/12 V/24 V) X11:1, 3: +24 V DC
Max. output power	300 W
Dimensions (L * W * H) weight ambient temperature	200 * 120 * 40 mm 0.8 kg -20 ... 60 °C

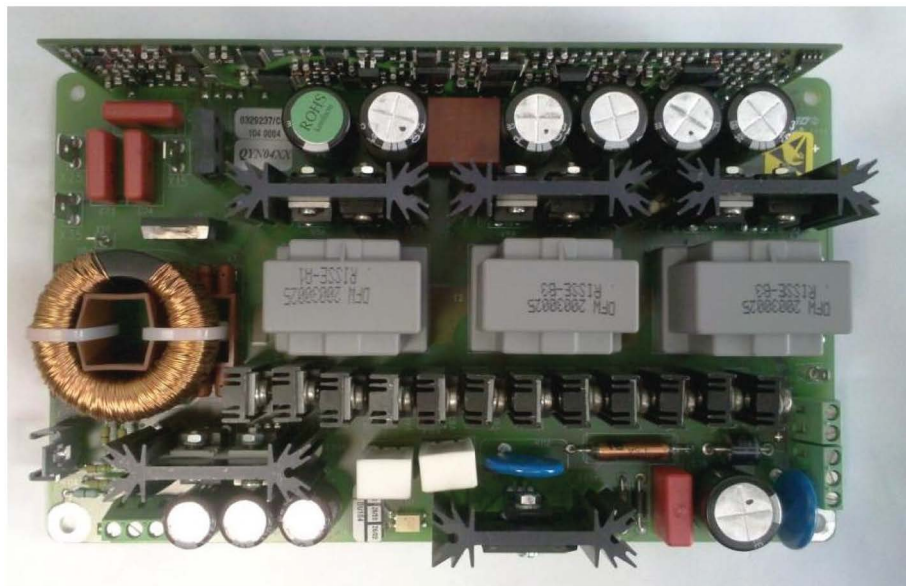

Figure 3-12 PC board of the pre-switch mode power supply (pre SMPS 300W)

3.3.16 Water cooling

3.3.16.1 General information about water cooling

Cabinet units can optionally be purchased with water cooling. From the type designation 2T..-7... you can identify that a unit is equipped with water cooling. Water cooling is adapted to the existing conditions, Further information can be found in the order-related documentation.

The "Water cooling" section describes the design of the direct water cooling with open cooling circuit. Recooling of the coolant is not performed. Provide corresponding cooling of the water on-site.

3.3.16.2 Direct water cooling diagram

Structure

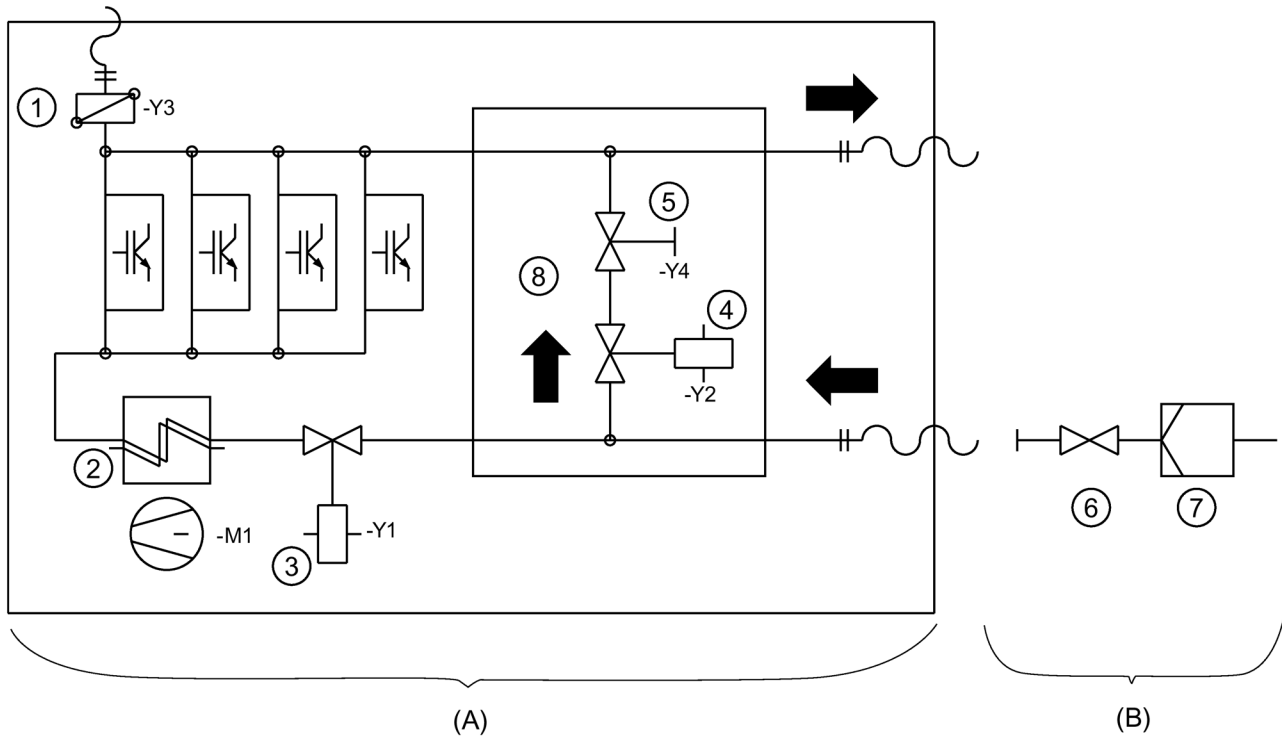

- (A) Components in the inverter cabinet
- (B) Components provided by the customer
- ① Ventilation
- ② Air / water heat exchanger with fan for interior
- ③ Electromagnetic valve NC
- ④ Electromagnetic valve NO
- ⑤ Stop valve, regulation of the flow rate
- ⑥ Flow rate regulation valve
- ⑦ Filter
- ⑧ Bypass - The version is optional

Figure 3-13 Diagram - Direct water cooling

3.3.16.3 Connecting water cooling

Procedure

- Connect the water cooling to the three low-pressure hoses which are installed approx. 2 m above the bottom edge of the cabinet. The hoses are labeled as follows:
 - Inlet
 - Return flow
 - Ventilation
- Install a fine filter with approx. 50 µm mesh size upstream of the inverter at the installation site.

3.3.16.4 Venting the water cooling

Procedure

- If counterpressure builds up in the return line, vent the water cooling.
 - Also vent the water cooling if it is operated in an enclosed system.
1. Before venting the system, switch off the inverter and lock it out so that it cannot be switched on again.
 2. Open the solenoid valve +H1.K2-Y1 to vent the water cooler.
Proceed as follows:
 - Open the isolating blade terminals +H1.K1-X5(or X4):12 and ...:13.
 - At terminals +H1.K1-X5(or X4):11 and ...:14 connect a 230 V AC auxiliary power supply.
 - Open the water supply.
 - Open the manual valve +H1.K2-Y3 to vent until no more air exits. The valve is located on the top side at the back on the left.
- Hose bushings and hose clamps are required to establish the connection:

Table 3- 10 Hose sizes

Hose sizes	½ "	¾ "	1 "	1 ½ "
Hose outer diameter	24 mm	30 mm	37 mm	51 mm

3.3.16.5 Decommissioning and shutdown

Procedure

- Empty the water cooling system if the inverter is decommissioned or is out of operation for longer periods of time. You can find further information in the documentation 4BS0698.
- Note that putrefaction products are produced if the cooling water does not flow and that damage due to frost occurs if the unit is stored at temperatures below 0 °C.

NOTICE
Frost damage Material damage can occur if the water cooling is exposed to frost without being drained. Drain the system in order to avoid damage. Disconnect the hoses from the connection points. Proceed as described for the venting. For complete purging, blow compressed air into the supply hose while the venting valve is closed until no more water exits.

The water cooling system is empty when the inverters are shipped from the manufacturer's plant.

3.3.16.6 Cooling water additives for the closed inverter cooling with cooling unit (optional)

Use a cooling water additive for the closed cooling system of the inverter.

Siemens recommends the agent "Antifrogen N" made by Clariant as a cooling water additive. The concentration of this additive can be adjusted to provide the required level of frost protection.

A minimum concentration of 20 % by volume provides anti-freeze protection down to -10 °C. An Antifrogen / water mixture of 1:2 provides anti-freeze protection down to -20 °C.

Unpolluted water mixed with a minimum concentration of 20 % by volume Antifrogen N prevents the growth of microorganisms and the formation of algae.

If you need more detailed information and recommendations regarding cooling water additives, then refer to your order-specific inverter documentation. For further information, please refer to document 4BS0698.

Description

3.3 Accessories

Preparations for use

4.1 Transporting inverter

Procedure

- Persons operating cranes and fork-lift trucks must be appropriately qualified.
- Only use approved, undamaged and adequately dimensioned lifting equipment. Check the equipment before using it.
- Observe the information in Chapter "Technical data for transportation (Page 194)".



! WARNING

Falling loads

If you are standing under a suspended load, then you are at risk of injury if the load falls off the hoisting gear. This can result in death, serious injury or material damage.

Never stand in the area beneath a suspended load.

! WARNING

Accidents during transport and when lifting

This can result in death, serious injury or material damage.

Carefully observe the transport instructions in this document as well as the generally valid accident prevention regulations – especially BGI 556.

Always wear personnel protective gear such as protective footwear and gloves and a helmet.

The converters are packaged by the manufacturer so that they can be transported by truck.

NOTICE

Damage to converters during transport

The converters can be damaged if they are incorrectly transported.

Observe the environmental conditions for transport provided in the technical data.

4.1 Transporting inverter

- Transport compact devices with cardboard packaging horizontally and cabinet equipment with plastic bubble wrap upright on wooden pallet.
- Converters are highly sensitive electronic devices. Pay attention to the stickers and warnings on the packaging.
- Only transport the equipment with modern, air suspension trucks on asphalt roads. If you cannot comply with these conditions, package the devices in accordance with the special requirements. Consult the factory for this, for example for marine packaging.
- Never lift the compact devices using the plastic cover, but always from below according to the following diagrams.



Lifting compact devices - wrong



Lifting compact devices - correct

NOTICE

Damage to converters during transport

When returning the unit, only transport it in the original packaging as otherwise the unit could be damaged during transport which means that the warranty becomes null and void.

 **CAUTION**

Risk of injury when lifting heavy loads

Compact units, depending on the type, from frame size K3, weigh more than 30 kg. Do not try to manually lift devices more than 30 kg.

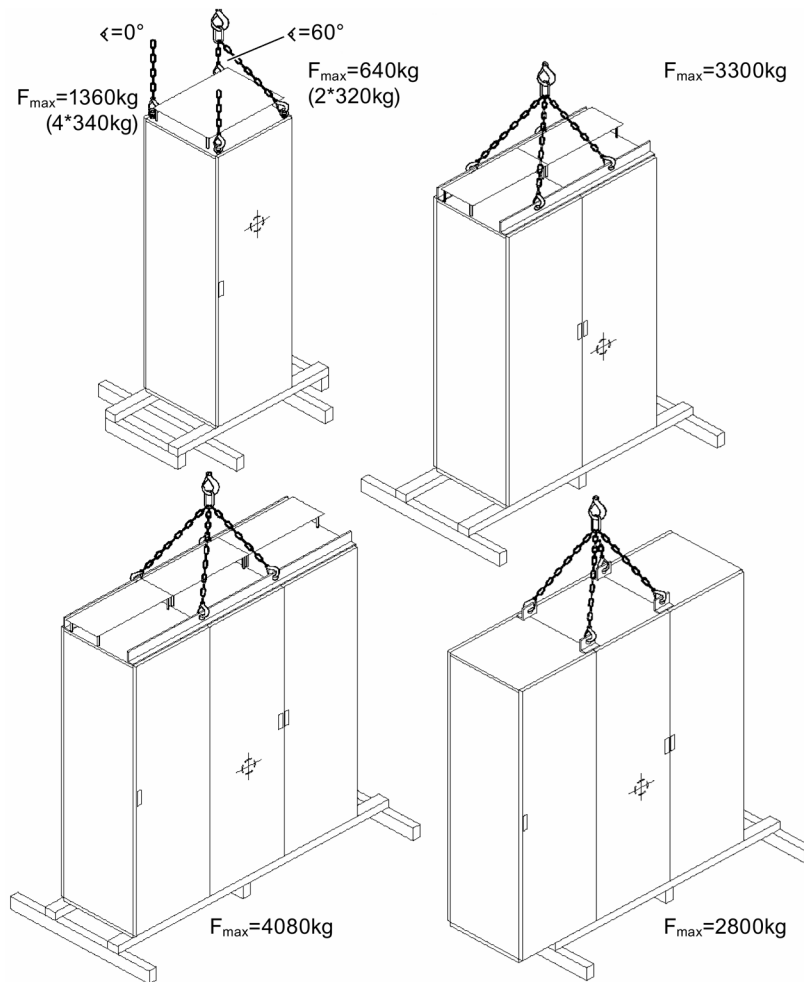

Figure 4-1 Lifting with a crane

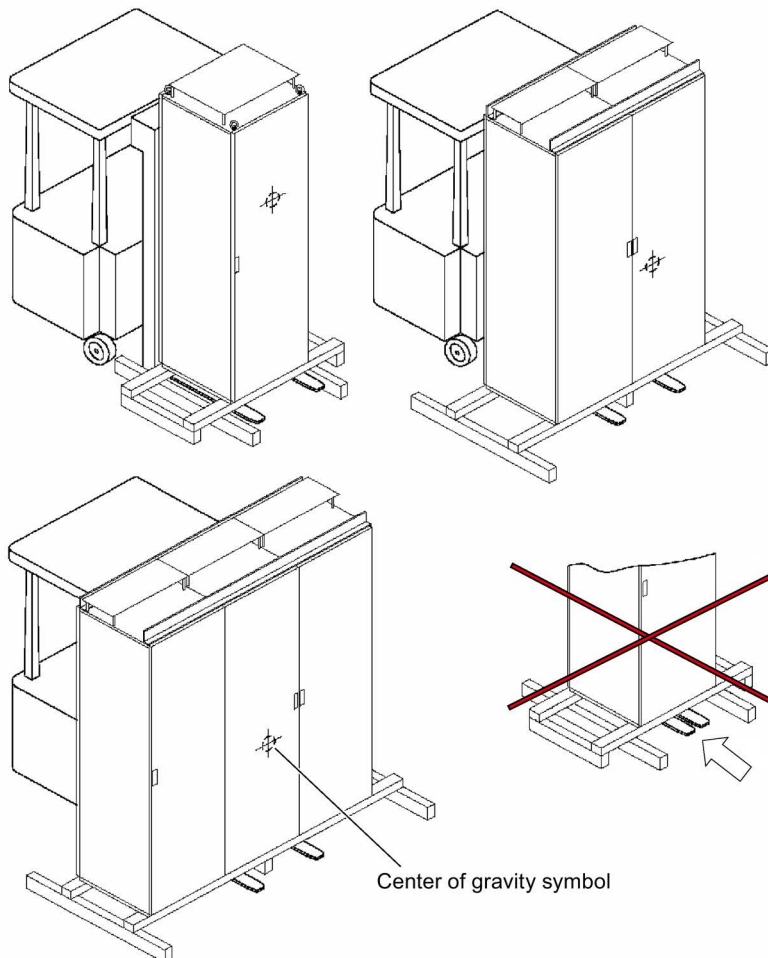

Figure 4-2 Transport with forklift

4.2 Storage of the inverters

- Only store the equipment in a dry storage area with undamaged packaging.
- Observe the information in Chapter "Technical data for storage (Page 194)".

NOTICE

Destruction of the inverters as a result of improper storage

Observe the environmental conditions for storage stated in the technical specifications. The inverters will be destroyed if you store them outdoors. Store the inverters in enclosed, dry rooms.

! WARNING
Injury due to explosion of capacitors

If the unit has been stored for longer than two years, the DC link capacitors can explode during commissioning. Reform the DC link capacitors if the unit has been stored for longer than two years. Contact the factory to determine what measures must be taken.

4.3 EMC

4.3.1 Install and connect in accordance with EMC.

Note the following rules regarding the installation and connection of inverters:

- Connect the cable shield over a wide area and with low inductance. Placing the shield over bundles of wires has practically no shield effect.
- If you also want to use the shield as PE conductor, then connect the shield twice.
 - For EMC reasons, connect the shield through a low inductive connection with the largest possible surface area.
 - Use a plait when connecting to the PE rail as protective measure.
- For signal lines with Sub-D male or female connector, place the shield over the Sub-D connector or socket. When connecting an external display at -X51, you must also connect the shield at the entry point to the housing.
See also Chapters "External display (Page 54)", "Mounting an external display (option) (Page 88)" and "Connection for optional external display with RS 485 (Page 155)".
- Install cables in such a way that there are no crossovers between control cables and power cables. If you cannot prevent a crossover on the cable ducts, then make the crossover at an angle of 90°.
- Ensure that all metallic parts of the switch cabinet are surface-connected with good conductivity. Connections with paint layer are not permitted.
 - Use contact disks or galvanized plates.
 - When connecting the switch cabinet door to the switch cabinet, use grounding straps that are as short as possible
- Connect all circuit breakers, relays, solenoid valves etc. in the switch cabinet to RC interference suppressors.
 - Do not use any diodes or varistors.
 - Install the protective circuit directly on the relevant coil.
- Twist unshielded wires. This particularly includes analog signals of the same power circuit i.e. supply and return wires.
Keep the area between supply and return wires as small as possible in order to avoid unnecessary loop antennas.

- Separate the power cables connected to the inverter input and connected to the inverter output by spacing them or by using grounded separating plates.
- You may interrupt the shielding of power cables by installing components such as output contactors, reactors, sine filters, etc. Mount the components on a galvanized sheet. The sheet simultaneously provides shielding for the incoming and outgoing motor wires.

4.3.2 Examples for correct EMC connection

You can see below some examples of expert connection of shielded cables at compact units.

If you would also like to apply cable shields with metal cable ties or metal clamps, install shielding buses for cabinet devices.

Cable entry on a compact device with shield connection using metallic cable ties

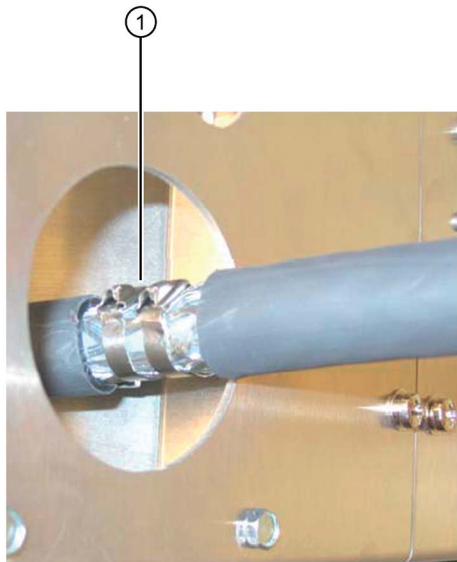

Cable entry of small control lines with shield on the case and signal lines with shield on the Sub-D connector

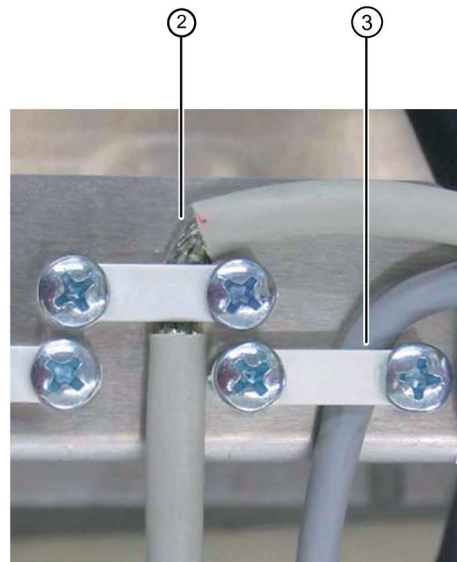

Correct connection for EMC - Variant 1

Correct connection for EMC - Variant 2

- ① Line or control connection from approx. 10 mm outside diameter
- ② Control cable up to approx. 10 mm outside diameter
- ③ Signal cable

You can also use EMC threaded connections instead of the metal cable ties. In this case, remove the sheet metal with the cable tie lugs.

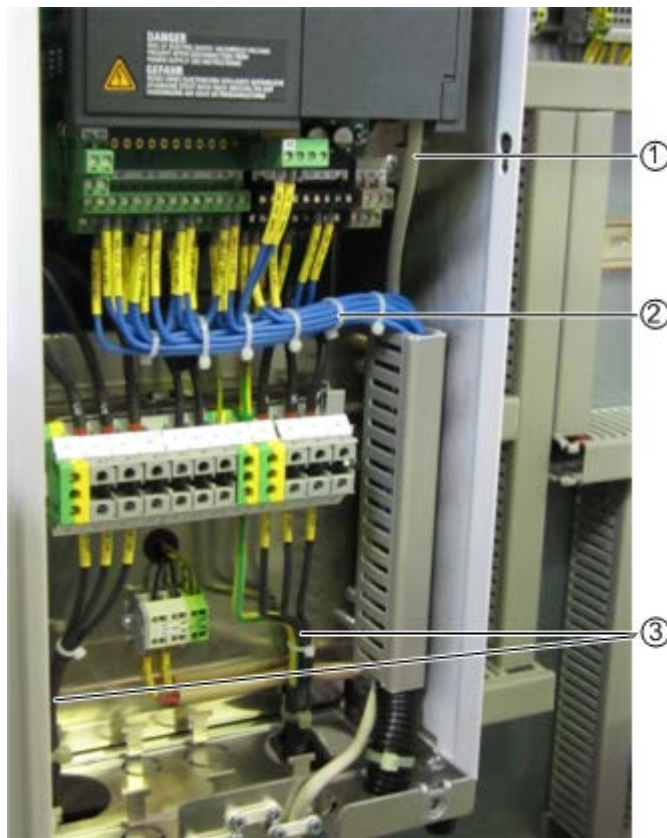

- ① Signal cable
- ② Control cable
- ③ Motor and power supply cable

Figure 4-3 EMC - wiring overview

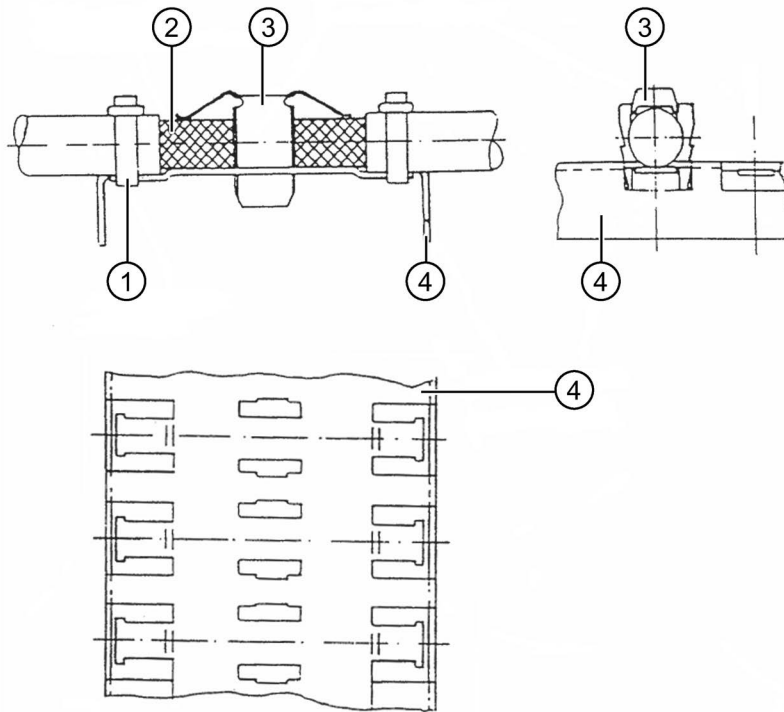

- ① Cable tie
- ② Place with insulation removed
- ③ Contact clip
- ④ Shielding bus

Figure 4-4 Shield connection for cabinet devices

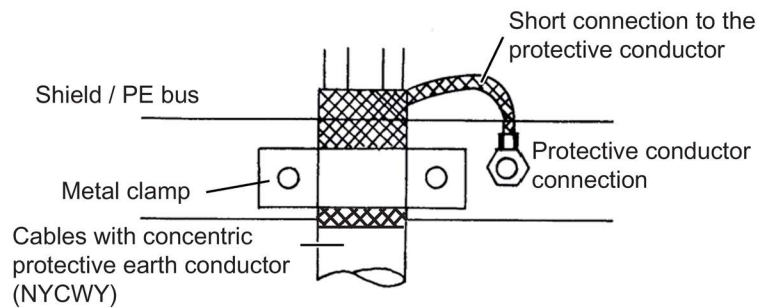

Figure 4-5 Shield connection for cable type NYCWY

4.3.3 Radio interference class

You can read the radio interference class of the inverter at the version designation of the rating rate or from the order confirmation. You can find additional information in Chapter "Order numbers MLFB / Type designations (Page 31)".

4.3.4 EMC environment category

The noise immunity of this converter complies with the highest environment category "industrial environment" according to EN 61800-3. Nevertheless, converter problems can occur if other devices exceed EMC limit values for interference emission. In this case, contact the Service Department of the manufacturer.

Table 4- 1 Environmental categories and classification of units

Category and environment according to EN 61800-3	1st environment (residential area - public grid)		2nd environment (industrial area - non-public grid)	
Categories	C1	C2	C3	C4
Classification of units	Grounded line supply			IT line supply or I > 400 A
	Optional for compact devices	Compact devices	Cabinet units	All units

Category C1: Product with rated voltage < 1000 V, use in the 1st environment

Category C2: Product with a rated voltage of < 1000 V, for use in the 1st environment and installed and commissioned by technical personnel knowledgeable about EMC

Category C3: Product with rated voltage < 1000 V, use in the 2nd environment

Category C4: Product with a rated voltage of ≥ 1000 V, rated currents ≥ 400 A or used in a complete plant or system in the 2nd environment

If the application requires category C2, then the system must be installed by technical personnel knowledgeable about EMC.

In addition, the following note also applies:

Note

For units in category C2 the following applies:

"This is a product, category C2 according to EN 61800-3. If not correctly installed and commissioned, this product can cause radio frequency interference in residential areas. In this case, it may be necessary for the company operating the unit to take corresponding measures."

If the application requires category C3, then the following note applies:

Note

For units in category C3, the following applies:

"This product is not suitable for connection to a public low-voltage grid, which supplies residential buildings. When connected to a public low-voltage grid, high frequency interference can be expected."

4.4 Realizing operation in the explosion-protected zone

Cable lengths

When professionally installed, the cable lengths listed can be achieved without requiring any additional measures.

Table 4-2 List of cable lengths

Radio interference suppression according to option	Category and environment according to EN 61800-3		
	1st environment (residential area - public grid)		2nd environment (industrial area - non-public grid)
	C1	C2	C3
L00 (Class A)	0 m	30 m	50 m
L02 (Class B)	30 m	50 m	100 m

4.4 Realizing operation in the explosion-protected zone

Converters in hazardous zones

 WARNING
Explosion hazard
If you operate the converter in hazardous zones, explosions can occur which cause property damage, serious injuries or death. Only operate the converter in safe, non-hazardous areas.

Motor in the Ex-Zone

Motors connected to the converter can be operated in the hazardous zone. Also observe the following conditions:

- Ensure that the motor is approved for converter operation and that it has a corresponding rating plate for converter operation.
- Ensure that the motor is approved for the Ex-Zone. Also check the motor rating plate.
- Ensure that the motors are equipped with PTC thermistors according to DIN VDE V 0898-1-401:2020-03. Connect these PTC thermistors to the peripheral board - X3:90 to 93. You then protect the motor against an inadmissible temperature rise due to overload according to DIN EN 60079-14/ VDE 0165-1 and EN 50281-1-1 (dust EX).
- Observe the safety regulations for use concerning motors in the Ex-Zones e or d. Directives 2014/34/EU and EN 60079-14 regulate this use.
- Ensure that the motor is now only operated in the intended speed control range. Under "P-MOTOR DATA" and "P-DRIVE DATA" enter the values stated on the motor rating plate for "fmin" and "fmax".

- Do not exceed the maximum motor cable length, otherwise impermissible voltage increases can occur. You can find more detailed information in Chapter "Motor connection (Page 98)".
- Ensure that Ex e-motors are tested for increased safety together with the converter at the manufacturer's factory. The system must not be operated without the test report.
- In the case of Ex e motors, set the values for "I contin.", "I short" and "t short" to the values specified by the manufacturer. Do not change these values again without consulting the motor manufacturer.
- Protect converter-fed motors in the hazardous zones using PTC thermistors. An evaluation circuit for the motor PTC thermistor is integrated in the "peripheral board 2 / 4" option for this. You can find more detailed information in Chapter "Peripheral boards 1 to 4, -A95, option G02 to G05 (Page 37)". The converter is electronically shut down.

Safety during shutdown

The risk analysis according EN 1050 or DIN EN ISO 14121 (draft standard) indicated that in comparison to the shutdown using contactors, only the hazard due to dangerous shock currents occurs in the converter.

Due to the redundant design of the electronic shutdown route, it is achieved that the shutdown is still ensured even if a fault in the electronic shutdown route itself occurs.

As components proven in operation are used, the converter complies with DIN EN ISO 13849-1:2015 category 2, PL c.

- If you do not use this electronic shutdown, the motor PTC thermistors must be routed via ATEX-certified thermistor evaluation units, e.g. CALOMAT® CK140 ... CK145.
- If you use CALOMAT® devices, you must use a line contactor on the input side.
 - In this case, loop the contact of the CALOMAT® directly into the coil circuit of the line contactor.
- Otherwise, connect the line contactor according to the description of the main contactor function in Chapter "Protective functions (Page 156)".

Installation

5.1 Installing inverter - General notes

- Install the inverter so that clean and dry cooling air can enter and leave without obstruction.
- Maintain the cooling air clearances stated in the dimension drawing.
- Read the degree of protection of the device off the rating plate.
- Note the following information about the degrees of protection:

Device	Version	Degree of protection according to EN 60529	NEMA type
Compact	Standard	IP20	Open Type
	Option	IP21	Open Type
Cabinet/ 2X cabinet units	Standard	IP21	NEMA1 *
	Option	IP23	NEMA1 *
	Option	IP41	NEMA1 *
	Option	IP43	NEMA1 *
	Option	IP54	NEMA1 *
	Option	IP55	NEMA1 *

* Higher NEMA types on request

Open Type

The compact devices are designed in accordance with degree of protection IP20 acc. to EN 60529 and as open-type devices acc. to UL 50. This ensures protection against electric shocks. To ensure protection against mechanical stress and climatic conditions too, the components should only be operated in housing/cabinets/rooms that fulfill the requirements stipulated in EN 60529 and are designed as enclosure types according to UL 50 (at least NEMA 1).

NOTICE

Dirt

If you do not protect the device against large accumulation of dust, high concentration of chemically active harmful substances, mold formation or the penetration by vermin, this can result in damage to and failure of the device.

Take suitable measures to protect the unit against these environmental influences. Observe the specified environmental conditions in the technical data.

5.2 Installing compact devices

Procedure

- Install the compact devices directly in a control room or install compact devices in a switch cabinet.
- When installed in a control cabinet, carefully note that the inverter cooling is not designed for any counter air pressure.
- If you use switch cabinets with filters, provide corresponding cabinet fans for the equalization.

We recommend the following procedure when mounting the compact unit to walls or panels:

1. Prepare the holes for the four fixing screws. Refer to the technical data for the relevant dimensions.
2. Screw in the two lower screws until they have taken a firm grip.
3. Lift the compact unit, if required using suitable lifting equipment, onto the two lower screws. The hole in the upper center of the base plate can be used to lift the unit using a hook.
4. Press the compact unit against the panel and tighten the upper two fixing screws.
5. And finally tighten the two lower screws.

To remove, first release the lower screws, then the upper screws and lift the unit from the panel.

5.3 Protective cover IP21 for compact and compact Plus devices

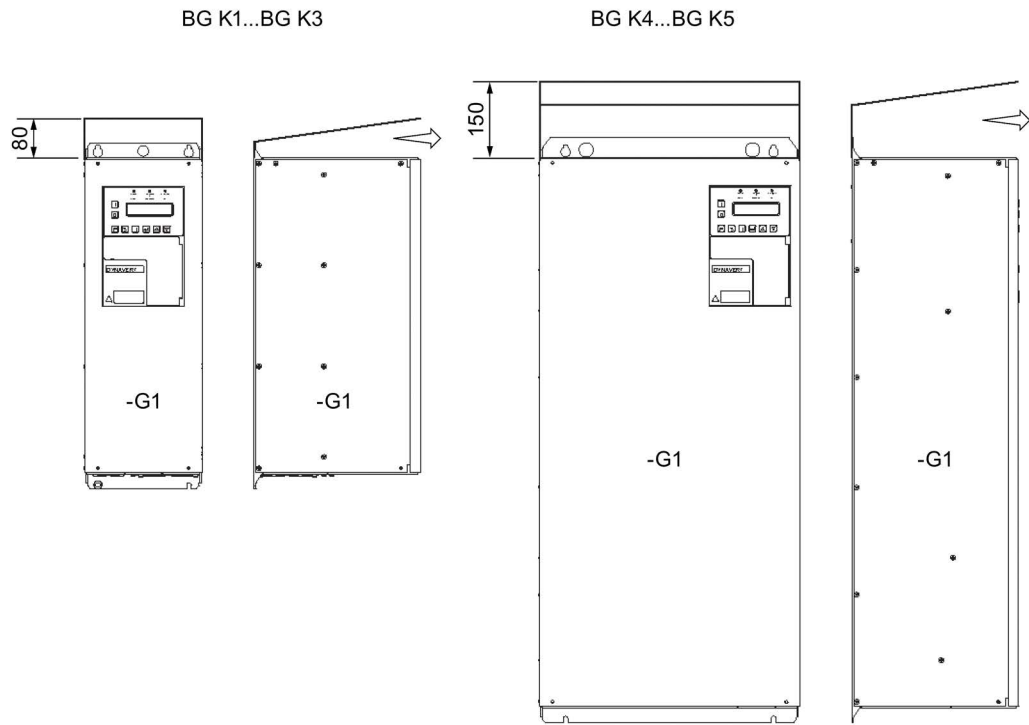

Figure 5-1 Canopy IP21

All compact units have degree of protection IP20. The canopy with degree of protection IP21 is available as an accessory for all compact and compact Plus units. The canopy is 5 mm wider on both sides than the inverter. Take account of this clearance for the alignment. Leave the outlet area at the front clear.

Proceed as follows to install the canopy supplied loose:

1. Screw the inverter without canopy onto a mounting plate. Do not tighten the top two mounting screws completely.
2. Slide the cover under the not yet completely tightened mounting screws.
3. Tighten the mounting screws completely.

With degree of protection IP21, the type code changes from 2T2A.....-... to 2T3A.....-... .

5.4 Installing cabinet units

- Install cabinet units on level mounting shelves. Wall mounting is permitted.
- If no clearances are stated in the dimension drawing of the order documentation, cabinets can be arranged next to each other.
- Provide the corresponding openings for the cable entry.
- Ensure that the cabinet frame is resting on the floor.
- If the cable opening is very large, anchoring to the floor increases the safety.
- If larger units have been separated for transport, make all the connections at the separation points again.

NOTICE
Overheating If you do not remove the transport rails installed on the canopy before commissioning, the inverter can be damaged due to overheating. Remove the transport rails before commissioning.

Canopy

Install the protective covers on the top of the cabinet. Proceed as follows:

1. Remove any transport rails present. Keep these for later transport.
2. Screw four bolts into the threads provided on the inverter cabinet.
3. Put on the cover and firmly screw on the cover using the screws provided.

NOTICE
Foreign bodies in the cabinet If you drop washers or screws into the cabinet during installation, this can result in destruction of the device. Ensure that no washers or screws fall into the device.

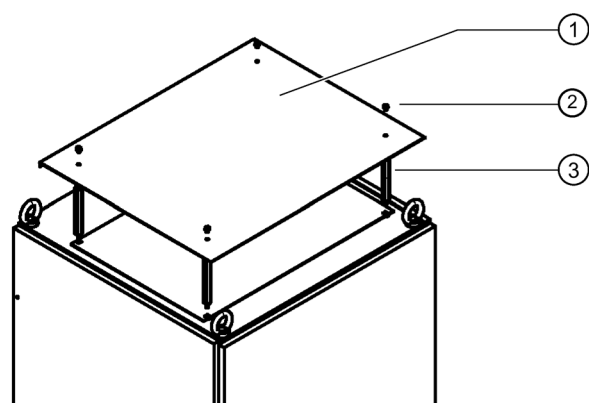

- ① Canopy
- ② Screws
- ③ Bolts supplied in the switch cabinet

Figure 5-2 Canopy

5.5 Mounting an external display (option)

The external display with the item number L0296033 has the same functionality as the internal display. You can connect the display to the inverter at two connectors:

- At the RJ-10 connection -X26, and only for installation in the control cabinet with a maximum cable length of 5 m.
- At the 9-pin D-sub connector -X51 and with a supplementary 24 V voltage supply for a maximum cable length of 1000 m.

Procedure

Use the display in control panels or doors. Note the following dimensions for the opening:

Width × height [mm]: $138^{+1} \times 92^{+0.8}$

The degree of protection is IP54.

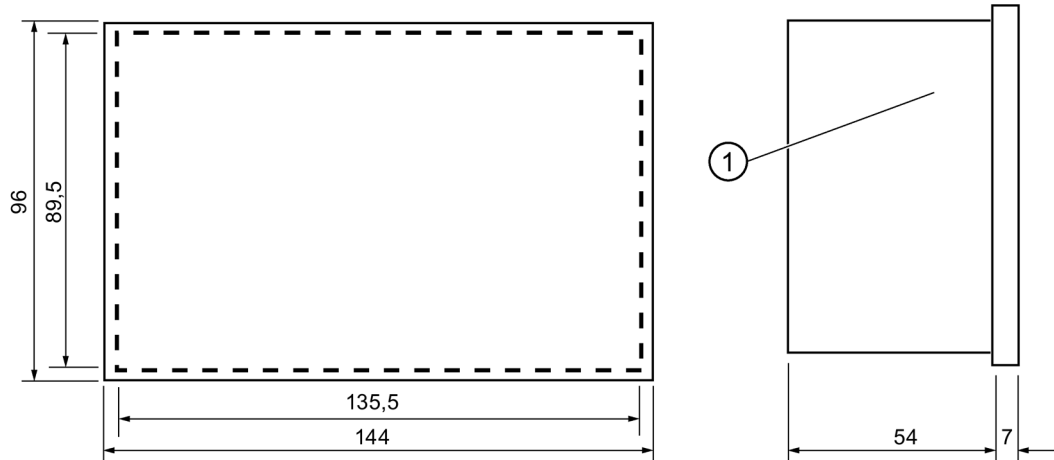

① Contrast setting

Figure 5-3 Dimension drawing - External display

Connection for installation in the switch cabinet door with maximum 5 meters connection cable length

Use the connecting cable with item number L0330600.

1. Shorten the cable to the required length.
2. Connect up the cables using end sleeves as illustrated in the diagram below.

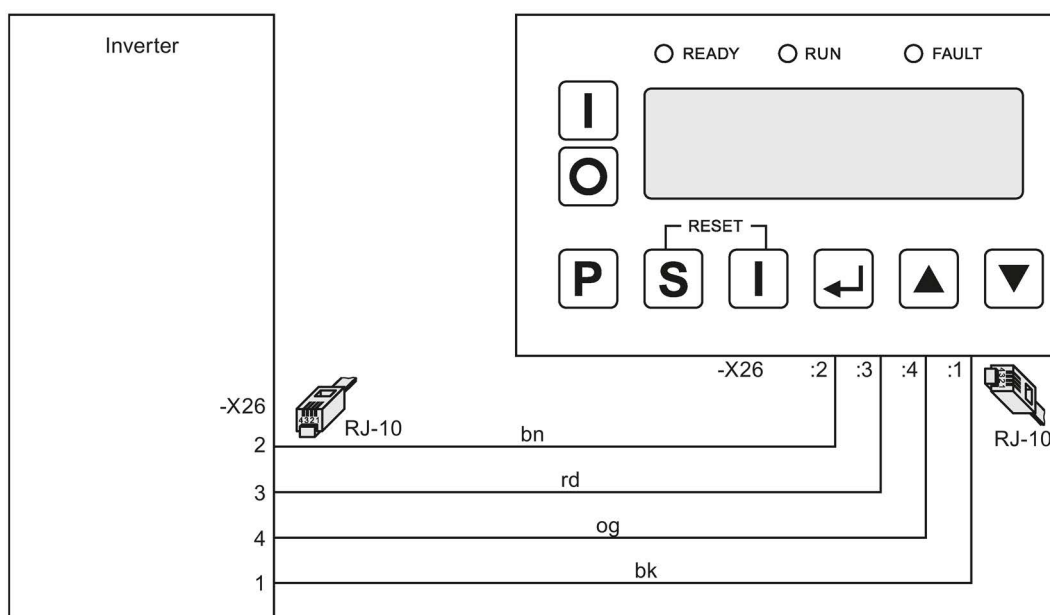

Figure 5-4 Display - Installation in switch cabinet door

Connection for external installation with maximum 1.000 meters connection cable length

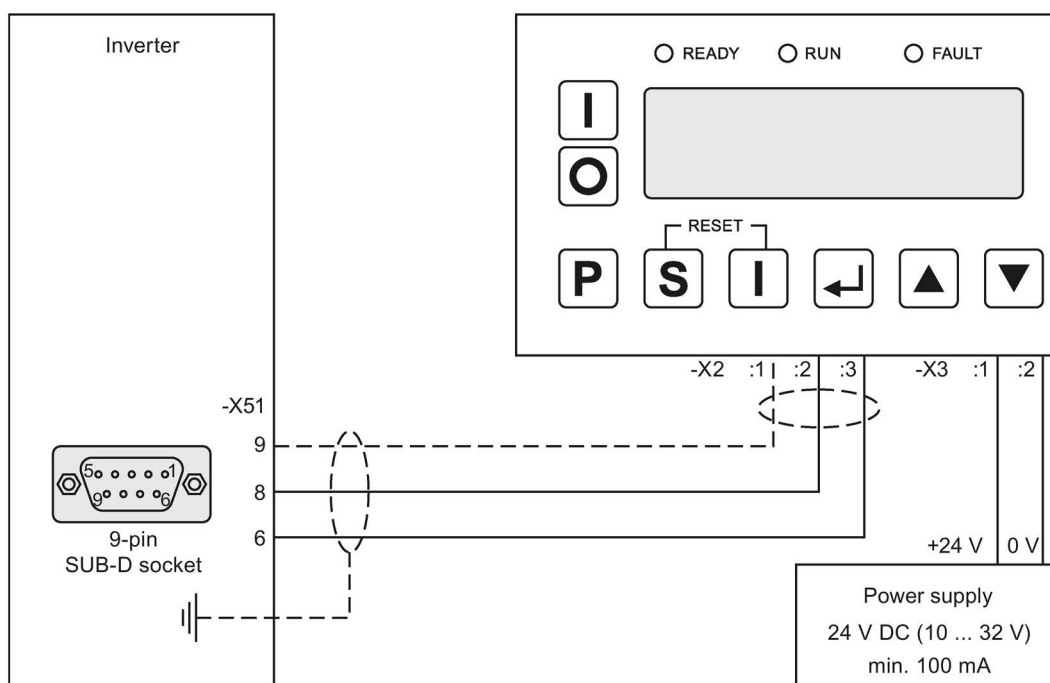

Figure 5-5 Display - external installation

Use shielded connection cables.

The connecting cable shield must be connected to the shield support provided at the entry point in the housing through the largest possible surface area (for grounding purposes).

Electrical connection

6.1 General information about the electrical connection

Please note the following regarding the electrical connection.

- When installing cables and selecting the cabling materials, make sure that you provide adequate isolation between circuits of different voltage classes (DVC), e.g. by using cables with reinforced insulation or by routing cables in separate cable ducts.
- Make sure that the cables are mechanically secured, e.g. using cable ties, against accidental disconnection.

For detailed information about cabling and connections, please refer to EN 61800-5-1, Chapter 4.3.8.

Note

Familiarize yourself with the local safety requirements and national safety guidelines, and always observe them.

NOTICE
<p>Use of aluminum cables at unsuitable terminals</p> <p>If you connect aluminum cables to terminals which are not suitable for the purpose, corrosion will develop. The equipment will be damaged as a result.</p> <p>Use special cable lugs which are designed for connecting aluminum and copper.</p> <p>Please contact the Siemens Service (Page 189) for advice about box terminals.</p>

6.2 Protecting the inverter

When protecting the converter a distinction must be made between the two cases.

Procedure when the motor has approximately the same rating as the converter ($I_{\text{mot}} \geq 0.5 * I_{\text{FI}}$)

- Protect the converter against short circuits.
- Take the fuse rating from the technical data, or select the next larger gL fuse based on the continuous converter input current stamped on the type plate.
- Install a gL fuse or circuit breaker upstream of the converter.
- When using a circuit breaker, set the thermal release to 1.2x the continuous converter input current as stamped on the type plate and the magnetic release to the lowest possible value between 1.5 and 2x the value of the continuous converter input current.
 - Only use circuit breakers without time grading (time discrimination).
 - The break time of the circuit breaker in the case of a short circuit must be less than 8 ms.

Procedure when the motor has a significantly lower rating than the converter ($I_{\text{mot}} < 0.5 * I_{\text{FI}}$)

- Protect the converter against short circuits.
- Dimension the fuse value as follows: $I_{\text{fuse}} < 2 * I_{\text{mot}}$. Use the next lower standard fuse value than calculated.
- Parameterize converter parameter "P-CONVERTER DATA/I contin." as a maximum to the fuse value.
- Install a gL fuse or circuit breaker upstream of the converter.
- When using a circuit breaker, set the thermal release to 2x the rated motor current as stamped on the rating plate, and the magnetic release to the lowest possible value between 1.5 and 2x the value of the continuous converter input current.
 - The break time of the circuit breaker in the case of a short circuit must be less than 8 ms.

6.3 Circuit breaker

In order to safely disconnect the inverter from the line supply, install a main switch or a circuit breaker upstream of the inverter.

The main switch or the circuit breaker must be capable of carrying at least 1.2x the rated inverter current.

The switching capacity of the main switch or the circuit breaker must correspond to the short-circuit current of the line supply system.

6.4 Connecting control cable

- Connect the control cables as described in Chapter "Communication Options (Page 129)", or according to the equipment documentation supplied.
- Use shielded, twisted pair cables for the connection of signal lines in order to increase the signal quality.
- When selecting cables and conductors and installing them, it is essential that you observe the information provided in Chapter "Protective separation according to EN 61800-5-1 (Page 145)".
- Instructions for EMC-compliant installation is provided in Chapter "Install and connect in accordance with EMC. (Page 75)".
- You can find additional information about the control cable terminals in Chapter "Technical data of the control cable terminals (Page 201)".

6.5 Line supply connection

6.5.1 Suitable supply line configurations

The converters are suitable for the following line supply types:

Table 6- 1 SINAMICS G180 T7 and appropriate line supply types

Line voltage	Type designation	Line system type
400 V	2T...40-...	TT or TN line system, grounded
500 V	2T...50-...	TT, TN or IT line system, grounded or not grounded
690 V	2T...60-...	TT, TN or IT line system, grounded or not grounded

Table 6- 2 SINAMICS G180 R7 and appropriate line system types

Line voltage	Type designation	Line system type
400 V	2R...87400-...	TT or TN line system, grounded
690 V	2R...87600-...	TT or TN line system, grounded



! WARNING

Explosion of the Y capacitors

If you operate units, category C1, C2 or C3 (radio interference suppression class A or B) with type designation "2T...-.....A/B..." on ungrounded mains power supplies, then this can destroy the Y capacitors at the line supply input. Serious injury and death can occur. Only use units without RFI suppression filter with the type designation "2T...-.....O..." on an ungrounded mains power supply. IT mains power supplies are not grounded.

6.5.2 Dimensioning mains power cables

Dimensioning

- Voltage stress
Use cables with adequate voltage strength; we recommend at least $U_0/U = 0.6/1$ kV.
- Current load
 - Dimension the cable cross section according to the applicable standards, e.g. VDE 0298.
 - Determine the current rating for the mains power cable according to the inverter input current stamped on the type plate.
- Precaution against injury due to indirect contact
Use an overcurrent protection device with additional potential equalization on the motor in order to avoid injuries due to indirect contact.
- Protective earth conductor
Due to the high leakage currents of the unit (> 3.5 mA), one or more of the following conditions must be fulfilled for fixed connection of the protective earth conductor:
 - The protective earth conductor must have a cross section of at least 10 mm^2 Cu or 16 mm^2 Al
 - Automatic tripping of the power supply in the event of interruption of the protective earth conductor
 - Installation of an additional terminal for a second protective earth conductor with the same cross section as the original protective earth conductor

6.5.3 RCD circuit breaker



WARNING

High voltages

This product can cause a direct current in the protective earth conductor. When a residual current device (RCD) or a residual current monitor (RCM) is used for protection in the event of direct or indirect contact, only an RCD or RCM of type B is permissible on the power supply side of this product.

- If you are using an RCD circuit breaker, then as a result of the high capacitive discharge currents, use an RCD circuit breaker with a high cut-off current. The leakage current basically depends on the type, length and laying of the motor cable.
 - Use at least a 500 mA RCD circuit breaker for inverter outputs up to approx. 100 kW.
 - Use at least a 1 A RCD circuit breaker for inverter outputs above 100 kW.

- The RCD circuit breakers used must be of type B "sensitive to all current types" with this label:



6.5.4 Connecting mains power cable to the inverter

You do not need any N conductor.

Procedure

- Only connect the inverter using a permanently installed connecting cable. Refer to the following table for the possible connection cross-sections for compact devices. The connection cross-sections for cabinet units can be found in the technical data provided in the inverter documentation.
- Observe the switch manufacturer instructions when connecting cables directly at the main switch. These instructions are provided in the circuit diagram pocket in the inverter cabinet. If necessary, special equipment cable lugs must be used in order to be able to utilize the connection spaces available.

Table 6- 3 Conductor cross-sections for compact devices

Frame size	Flexible cable	Rigid cable
BG K1	0,2 - 6 mm ²	0,2 - 10 mm ²
BG K2	4 - 16 mm ²	2,5 - 25 mm ²
BG K3	0,75 - 35 mm ²	0,75 - 50 mm ²
BG K4	2,5 - 120 mm ²	2,5 - 120 mm ²
BG K5	2,5 - 120 mm ²	2,5 - 120 mm ²
BG K51	2,5 - 120 mm ²	2,5 - 120 mm ²
BG K6	50 - 240 mm ²	50 - 240 mm ²

- Connect the mains power cables L1-L2-L3 to terminals U1, V1, W1 of terminal strip -X1 of the inverter: Refer to the technical data for the correct tightening torques for the power cable connection.

NOTICE

Destruction due to nonsymmetrical current distribution

In the case of inverters with higher pulse numbers, the rectifier can be destroyed as a result of the non-symmetrical current distribution. Pay attention to symmetrical current distribution. Use the same cable types and lengths as well as the same connection technology for every mains power connection. Route all cables on the same or a comparable route so that the cable temperatures are the same.

6.5.5 Inverter connection for different pulse operation

Inverters equipped with inputs with higher pulse numbers are available for higher outputs from approx. 500 kW; these inputs result in lower mains harmonics.

Connect the inverter to the mains power supply depending on the number of pulses used:

Table 6- 4 Mains connection dependent on the number of pulses used

Number of pulses used	Can be recognized in the type code:	Connection at the inverter at -X1:U1, V1, W1
6	2T.A-...	Three phases
12	2T.F-...	Two secondary transformer systems each with three phases, i.e. a total of six phases. Both systems must be phase offset by 30°, e.g. using the transformer vector group Dy5d6.
18	2T.K-...	Three secondary transformer systems each with three phases, i.e. a total of nine phases. The three systems must each be phase offset by 20°, e.g. using the transformer vector group Dy0y+20y-20.
24	2T.L-...	Four secondary transformer systems each with three phases, i.e. a total of twelve phases. The four systems must each be phase offset by 15°, e.g. using two transformers with the vector groups Dy5,25d6,25 and Dy4,75d5,75.

The type code can be found on the rating plate.

6.5.6 Adjusting the line voltage at the inverter

The inverters are suitable for different mains voltages: If your unit is different from the respective nominal line voltages of 400 V, 500 V or 690 V, you must adjust the mains voltage at the inverter.

1. Set parameter "P-INVERTER DATA/V mains nom." to your mains voltage.
2. Set the mains voltage on the device:
 - No adjustment is necessary for compact units with a width of 165 mm or 225 mm.
 - In the case of compact units with a width of 350 mm or 500 mm, you reconnect the jumpers according to the following table:

Rated voltage [V]	Voltage tolerance [V]	Necessary jumpers
230	184 ... 265	1-2 / 4-8
400*	320 ... 460	1-6 / 7-8
460	368 ... 529	1-5 / 7-8
500*	408 ... 587	1-3 / 7-8 / 4-5
575	464 ... 667	1-2 / 7-8 / 3-6
690	552 ... 794	1-2 / 7-8 / 4-5

*One of these values is preset.

The voltage tolerances specified in the table indicate the permissible voltage range of the fan power supply and not the permissible tolerances for the power connection of the device.

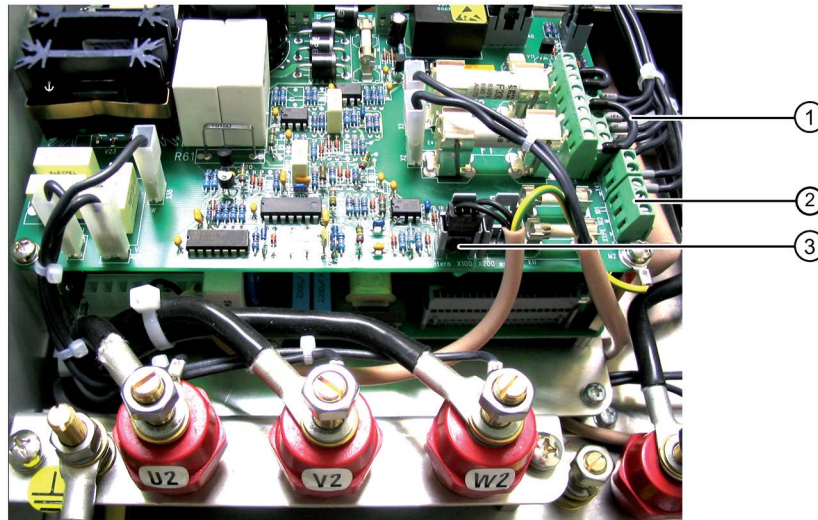

- ① Jumpers for rated voltage preselection
- ② Terminals -X101 and -X102 for an external control voltage
- ③ Terminal for preselection of the control voltage setting
 - View as in the picture: Internal power supply
 - Cable connected at connector -X200 : Power supply via terminals -X101 and -X102

Figure 6-1 Jumpers and terminals at the inverter

If a transformer is installed in a cabinet unit, the transformer connections must be changed to the correct mains voltage.

6.5.7 Precharging

The device is equipped with a precharging circuit using resistors, to softly precharge the DC link capacitors. This precharging is realized each time the power supply is switched on, or only after an optional line contactor in the device has closed.

Using the appropriate parameter assignment, you can define which operating command is used to close a line contactor installed in the device (see Chapter "Protective functions (Page 156)").

NOTICE

Material damage caused by switching too frequently!

The device can be damaged if the power supply is switched-on too frequently or an internal line contactor is switched too frequently.

- Do not switch your switching device in the power supply or an internal line contactor more often than once every 10 minutes.

6.6 Motor connection

6.6.1 Motor selection

Three-phase asynchronous motors or three-phase synchronous motors can be used for your inverter. The use of several motors simultaneously is permitted.

- The total of the motor outputs must not exceed the inverter output. You may operate smaller and larger motors in parallel on one inverter.
- Take into account during the motor dimensioning that additional losses in the motor are produced by the non-sine shaped motor current.
- Note that a motor without external ventilation will be cooled less at speeds less than the rated speed. Therefore, consult the motor manufacturer for the dimensioning of the motor.
- When using Siemens motors, refer to the list "UN03/UN04 Drehstrommotoren für drehzahlverstellbare Antriebe" to find the relevant inverter output.

6.6.2 Coil load

Note

High voltage peaks caused by switching edges

The switching edges generated by the inverter at the inverter output additionally stress the motor insulation. This results in high voltage peaks.

If you carefully observe the notes in this chapter, then peak voltages not exceeding 1560 V occur at the motor. Motors specially designed for inverter operation do not represent a problem. Contact the motor manufacturer if you wish to connect older motors, or motors that are not suitable for inverter operation.

For explosion-protected motors, carefully ensure that the specified peak voltage at the motor is precisely maintained.

6.6.3 Motor voltage and type of circuit

Operate the motor in the "star" or "delta" connection corresponding to the inverter parameterization.

In most cases, the motor voltage parameterized at the inverter is identical with the mains voltage. Check parameter "P-MOTOR DATA/V motor" to identify what has been parameterized.

6.6.4 Dimensioning motor cables

- Voltage load
Use cables with adequate voltage strength; we recommend at least $V_0/V = 0.6 \text{ kV}/1 \text{ kV}$.
 - Current load
 - Dimension the cable cross section according to the applicable standards, e.g. VDE 0298.
 - Determine the current of the motor cable according to the inverter output current, which you can find on the rating plate.
 - To comply with EMC directives, use cables with EMC shield - or at least cables with concentric protective earth conductor, type NYCWY.
 - For multi-system devices, connect the same number of motor cables at each system.
- See Chapter "Install and connect in accordance with EMC. (Page 75)".

WARNING

Capacitive leakage currents

An increased current can flow in the motor cable shield as a result of capacitive leakage currents. This can cause the cable to overheat. This can result in death, serious injury or material damage.

Use a shield cross section that is, as a minimum, half the line conductor cross-section: For a thinner shield or for a shield manufactured out of steel braiding, route a PE conductor, which, as a minimum, is half of the line conductor cross-section in parallel with the motor cable.

6.6.5 Dimensioning maximum motor cable length

The maximum cable length is determined by the following factors:

- Peak voltage at the motor
 - All converters are equipped with a du/dt filter. The filter limits the voltage increase time on the motor to $> 0.5 \mu\text{s}$.
 - A motor peak voltage of 1,560 V is maintained for the maximum cable lengths stated in the table.
- Inverter load
 - The capacitive load of the inverter increase with increasing cable length and/or increasing number of parallel cables.
 - The parameterizable inverter clock frequency influences the converter load. If you configure the minimum possible clock frequency, the inverter load then reduces so that a larger cable length can be connected.

Table 6- 5 Typical maximum motor cable lengths for different converter versions

Device type	standard version 2T..-.....-.....D...		Version with strengthened du/dt filter 2T..-.....-.....V...	
	Cable type		Cable type	
	NYCWY	NY Y	NYCWY	NY Y
Compact devices 400 V 2T..-(0...3)5400-... connected to line supplies up to 400 V	200 m	300 m	350 m	450 m
Compact devices 400 V 2T..-(0...3)5400-... connected to line supplies > 400 V	150 m	200 m	300 m	350 m
Cabinet units 400 V 2T..-(7...8)(5...6)40.-... connected to line supplies up to 400 V	-	-	300 m	350 m
Cabinet units 400 V 2R..-874.-....	150 m	200 m	300 m	350 m
Compact devices 500 V 2T..-(0...3)5500-...	-	-	300 m	350 m
Cabinet units 500 V 2T..-(7...8)(5...6)50.-...	-	-	250 m	300 m
Compact devices 690 V 2T..-(0...3)5600-...	150 m	200 m	300 m	300 m
Cabinet units 690 V 2T..-(7...8)(5...6)60.-...	100 m	140 m	250 m	300 m
Cabinet units 690 V 2R..-876.-....	150 m	200 m	300 m	350 m

The data in the table specifies the typical cable length in the sense of the distance between the motor and the converter when parameterizing the standard clock cycle frequency. Larger distances are also possible for individual types. Contact the factory for precise values if you are in the limit range or if there is a long distance between the motor and converter.

NOTICE

Damage to the converter output filter

If you lay too many wires in parallel for the motor cable, the capacitive current in the motor cable can increase unacceptably and destroy the converter output filter. In the case of operation with several motors or parallel wiring of motor cables, the maximum possible distance between converter and motor is reduced. Cabinet units are suitable for wiring in parallel. Contact the factory for the precise values. Reduce the number of parallel wires to permissible values.

NOTICE

Destruction of the motor or the converter output filter

If you exceed the maximum motor cable length, this can destroy the motor or the converter output filter. Consult the factory for longer motor cables.

NOTICE

Winding or bearing damage

If you use motors which are not designed for converter operation, premature winding or bearing damage can occur. Consult the motor manufacturer to find out whether the motor is suitable for converter operation. Please bear in mind that IEC 60034-17 is applicable to motors that are designed for line operation but are operated with a converter. Smaller values for the peak voltage apply here. Dimension the cable lengths after consultation with the manufacturer.

6.6.6 Connecting motor cable

Connect the motor to terminals U2, V2, W2 of terminal strip -X1 of the inverter.

Connect the motor cable shield to the shield supports provided through the largest possible surface area. The other alternative is to use EMC glands both at the motor and the inverter. If you use the cable shield as protective conductor, then you must connect this to the protective conductor connection so that it can conduct the appropriate current.

Refer to the technical data for the correct tightening torques for the power cable connection.

6.6.7 Overload and overtemperature protection of the motor

The converter is not equipped with electronic motor overload protection.

However, you have the option of connecting the motor PTC thermistor sensor to the converter:

- For non-Ex motors:

For standard devices, you can connect the motor PTC thermistor to terminals -X2:27 or -X2:28 referred to -X2:58. With the appropriate parameterization with binary signals "PTC X2:27" or "PTC X2:28", carefully ensure that you initiate the required response in the converter.

With the default parameterization, via terminal -X2:27 a device fault is initiated ("P failures 11") and via terminal -X2:28 a warning ("P-warning 7").

- For Ex motors:

For Ex motors you require the Z option -G03 (peripheral board 2) or -G05 (peripheral board 4) with ATEX-certified motor temperature monitoring.

You can find more information in the following Chapters:

- "Electronic shutdown for "Safe halt" / PTC inputs (Page 38)"
- "Z options with "Safe Torque Off" or ATEX shutdown (Page 42)"
- "PTC inputs for motor PTC thermistor (Page 47)"

Note

Using a shielded cable

Use a shielded cable to connect the PTC thermistor. Connect the shield to the shield support provided at the entry to the housing through the largest possible surface area. Observe the minimum cross section of the PTC thermistor cable in Chapter "Technical data and identification of the PTC thermistor input at peripheral boards 2 and 4 (Page 203)".

6.7 External control voltage

6.7.1 Use of external control voltage

In normal operation, the inverter generates the control voltage from the DC link voltage.

Use external control voltage in the following cases:

- For main contactor on the line voltage side
- If the display should also function when no mains voltage is present
- If the inverter should resume operation approx. 3 s faster than without external control voltage in the case of brief mains power failures. The initialization time of approx. 3 s does not apply in the case of external supply.

6.7.2 Connecting the external 230 V AC control voltage

6.7.2.1 Protecting/fusing the external 230 V AC control voltage

 WARNING
External control voltage without fuse protection
If you use an external control voltage without suitable protection (e.g. fuses), then overloads and short-circuits can occur. This can result in death, serious injury or material damage.
The device may only be operated with a protected external control voltage. Note the following recommendation.

Install one of the following options to protect the external control voltage:

- Miniature fuse in accordance with EN 60127: 2 A ... 6 A, slow, maximum 150 VA
- Miniature circuit-breaker: 2 A ... 6 A, characteristic D, maximum 150 VA

6.7.2.2 Switching over the hardware to an external 230 V AC control voltage

- Switch over the inverter from the internal control voltage from the DC link to an external control voltage.

Procedure

- Change over the white connector on the "switched-mode power supply" board from -X2 for "internal" to -X5 for "external".



Switching power supply with connector on internal control voltage



Switching power supply with connector on external control voltage

6.7.2.3 Preparations for accessing the "switching power supply" board

Preparing compact devices with size up to 165 mm

This instruction is applicable for compact devices up to a size of 165 mm with the identifier 2T..-07400-011 or 2T..-07500-015.

Procedure

1. Unscrew the blue cover at the screw above -X25 and lift up the cover.
2. Turn the two screws of the grey cover underneath by 90° and lift up the cover.
3. Undo all screws for the right-hand side panel which are visible from outside and one internal nut in the connection area. Lift off the side panel.
4. Replug the connector.
5. Reassemble in the inverse order.

Preparing compact devices with size up to 225 mm

This instruction is applicable for compact units up to a size of 225 mm with the identifier 2T..-07400-015 or 2T..-07500-037.

Procedure

1. Turn the four fixing screws of the gray cover through 90° and lift up the cover.
2. Unscrew the blue cover at the screw above -X25 and lift up the cover.
3. Turn the four fixing screws of the swivel section by 90°, swivel the swivel section to the right and clip the swivel section to the side panel according to the picture below.
4. Replug the connector.
5. Reassemble in the inverse order.

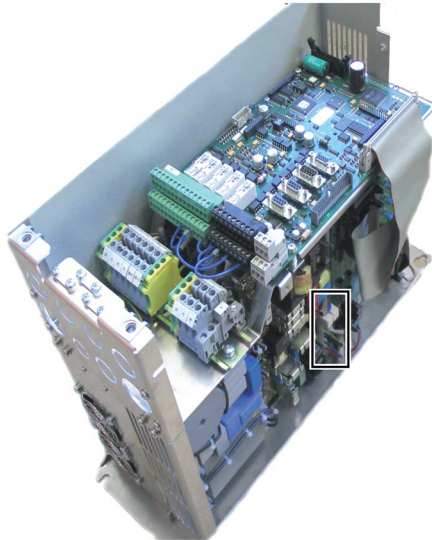

Compact frame size 165 mm long



Compact frame size 225 mm long

Preparing compact devices with frame size K4 with 400 V or 500 V

This instruction applies to compact units with the frame size K4 with L × W 775 × 350 mm and 400 V or 500 V rated voltage.

Procedure

1. Turn the four fixing screws of the gray cover through 90° and lift up the cover.
2. Unscrew the blue cover at the screw above -X25 and lift up the cover.
3. Remove the cover above the motor connection terminals.
4. Remove the "fan power supply" board with the five fine-wire fuses. Undo the four screws and unplug the cable for this.
5. The "switched-mode power supply" board is located below with a white connector and the sockets -X2 for "internal" and -X5 for "external".
6. Insert the connector into "external".
7. Reassemble in the inverse order.

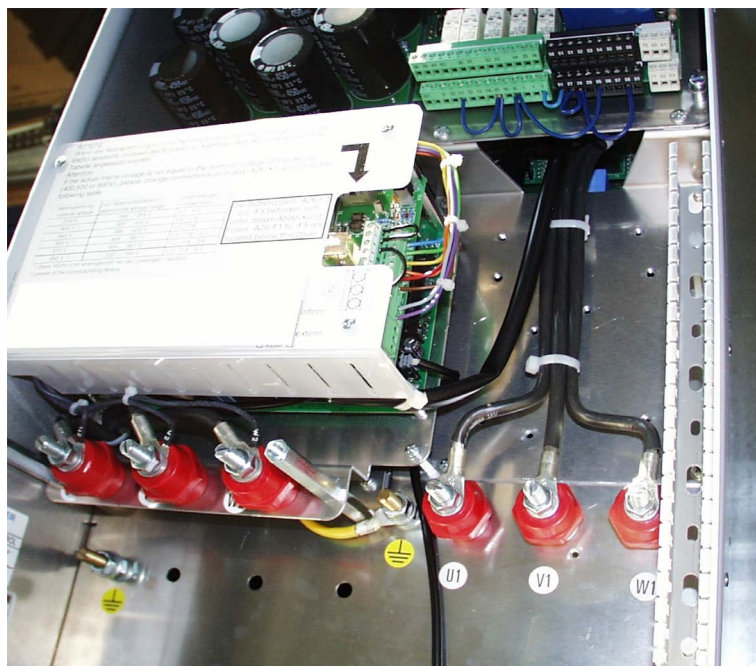

Figure 6-2 Compact device frame size K4

Note

Occurrence of malfunctions

Malfunctions can occur if you change over the connection of the sockets -X100 / 200 for "external" / "internal" on the upper "fan power supply" board. Leave this connection in its original configuration.

Providing compact devices with the frame size K4 with 690 V

This instruction applies to compact units with frame size K4 with L × W 775 × 350 mm and 690 V rated voltage.

Procedure

1. Turn the four fixing screws of the gray cover through 90° and lift up the cover.
2. Unscrew the blue cover at the screw above -X25 and lift up the cover.
3. Remove the cover above the motor connection terminals.
4. On the "fan supply" board with the five miniature fuses, change over the connector from socket -X100 to -X200.
5. Reassemble in the inverse order.

Note

Occurrence of malfunctions

Malfunctions can occur if you change over the connection of sockets -X2 / 5 for "external" / "internal" on the "switched-mode power supply" board. Leave this connection on "external".

Providing compact devices with frame size K5/51 with 400 V or 500 V

These instructions apply to compact units with frame size K5 or 51 with L × W (1125 or 1538)×350 mm and 400 V or 500 V rated voltage.

Procedure

1. Turn the four fixing screws of the gray cover through 90° and lift up the cover.
2. Unscrew the blue cover at the screw above -X25 and lift up the cover.

3. Turn the four fixing screws of the swivel section by 90°, swivel the swivel section to the right and clip the swivel section to the side panel according to the picture.

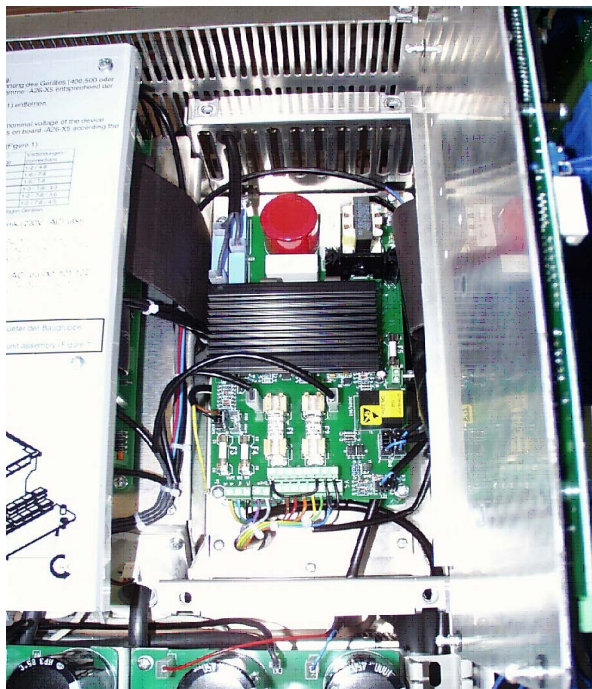

Figure 6-3 Compact unit with frame size K5 with opened control electronics

4. Remove the "fan power supply" board with the five fine-wire fuses. Undo the four screws and unplug the cable for this.
5. The "switched-mode power supply" board is located below with a white connector and the sockets -X2 for "internal" and -X5 for "external".
6. Insert the connector into "external".
7. Reassemble in the inverse order.

Note

Occurrence of malfunctions

Malfunctions can occur if you change over the connection of the sockets -X100 / 200 for "external" / "internal" on the upper "fan power supply" board. Leave this connection in its original configuration.

Providing compact devices with the frame size K5/51 with 690 V

These instructions apply to compact units with frame size K5 or 51 with L × W (1125 or 1538) × 350 mm and 690 V rated voltage.

Procedure

1. Turn the four fixing screws of the gray cover through 90° and lift up the cover.
2. Unscrew the blue cover at the screw above -X25 and lift up the cover.
3. Turn the four fixing screws of the swivel section by 90°, swivel the swivel section to the right and clip the swivel section to the side panel.
4. On the "fan supply" board with the five miniature fuses, change over the connector from socket -X100 for "internal" to -X200 for "external".
5. Reassemble in the inverse order.

Note

Occurrence of malfunctions

Malfunctions can occur if you change over the connection of sockets -X2 / 5 for "external" / "internal" on the "switched-mode power supply" board. Leave this connection on "external".

Preparing compact devices with frame size K6 with 400 V or 500 V

This instruction applies to compact units with the frame size K6 with L × W 1125×500 mm and 400 V or 500 V rated voltage.

Procedure

1. Turn the four fixing screws of the gray cover through 90° and lift up the cover.
2. Unscrew the blue cover at the screw above -X25 and lift up the cover.
3. Turn the four fixing screws of the swivel section by 90°, swivel the swivel section to the right and clip the swivel section to the side panel.
4. The "switched-mode power supply" board is located below with a white connector and the sockets -X2 for "internal" and -X5 for "external".
5. Insert the connector into "external".
6. Reassemble in the inverse order.

Note

Occurrence of malfunctions

Malfunctions can occur if you change over the connection of the sockets -X100 / 200 for "external" / "internal" on the upper "fan power supply" board. Leave this connection in its original configuration.

Providing compact devices with the frame size K6 with 690 V

This instruction applies to compact units with frame size K6 with L × W 1125×500 mm and 690 V rated voltage.

Procedure

1. Turn the four fixing screws of the gray cover through 90° and lift up the cover.
2. Unscrew the blue cover at the screw above -X25 and lift up the cover.
3. Turn the four fixing screws of the swivel section by 90°, swivel the swivel section to the right and clip the swivel section to the side panel.
4. The "fan power supply" board with five fine-wire fuses and the "switching power supply" board are underneath.
5. On the "fan supply" board, change over the connector from socket -X100 for "internal" to -X200 for "external".
6. Reassemble in the inverse order.

Note

Occurrence of malfunctions

Malfunctions can occur if you change over the connection of sockets -X2 / 5 for "external" / "internal" on the "switched-mode power supply" board. Leave this connection on "external".

6.7.2.4 Connecting the external 230 V AC for compact devices

Procedure

- Connect the external control voltage to the terminals 101 (L1) and 102 (N).

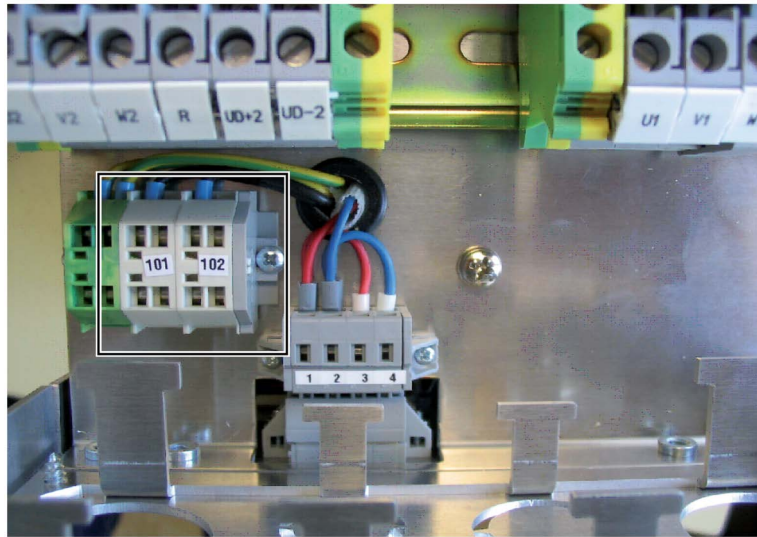

Figure 6-4 Connection for external control voltage

Use the following connection values:

Table 6- 6 Connection values for external control voltage

Maximum cross section	2.5 mm ²
Fuse protection	<ul style="list-style-type: none">• Miniature fuse in accordance with EN 60127: 2 A ... 6 A, slow, maximum 150 VA• Miniature circuit-breaker: 2 A ... 6 A, characteristic D, maximum 150 VA
Voltage	230 V + 15 % - 20 %
Frequency	47 Hz ... 63 Hz

For compact units with frame size K4, terminals 101 and 102 are located on a board under the plastic cover above the motor terminals.

6.7.2.5 Control voltage 230 V AC for cabinet units

Cabinet units access the control voltage for the electronics from the control transformer. Further information can be found in the wiring diagram of the unit.

6.7.3 Connecting the external 24 V DC control voltage

6.7.3.1 Protecting/fusing the external 24 V DC control voltage

NOTICE
External control voltage without fuse protection If you use an external control voltage without suitable protection (e.g. fuses), then overloads and short-circuits can occur. Material damage can result. The device may only be operated with a protected external control voltage. Note the following recommendation.

Install one of the following options to protect the external control voltage:

- Miniature fuse in accordance with EN 60127: 6 A, slow acting, maximum 100 VA
- Miniature circuit-breaker: 6 A, characteristic D, maximum 100 VA

6.7.3.2 Switching over the hardware to an external 24 V DC control voltage

- Change the converter from internal control voltage via the DC link to external control voltage.
- Replace the PC board switch mode power supply L0353151 by PC board SNT24V L0353161.

Procedure

Connect the external control voltage to the terminals 1 (0 V) and 2 (+24 V).



Figure 6-5 Connection for external control voltage

Use the following connection values:

Maximum cross section	2.5 mm ²
Protection	<ul style="list-style-type: none"> • Miniature fuse in accordance with EN 60127: 6 A, slow acting, maximum 100 VA • Miniature circuit-breaker: 6 A, characteristic D, maximum 100 VA
Voltage	+24 V DC \pm 15 %

Commissioning

Perform the commission according to the following instructions.

Read Chapter to operate the converter "Operation (Page 123)".

Use the commissioning instructions for commissioning a standard converter application. Information for special applications can be found in the corresponding sections. Contact the Service Stations of the manufacturer if necessary.

Use the provided commissioning service if required. Contact the Service Center to obtain a quotation for commissioning, see Service & Support (Page 189)

7.1 Checks without mains power supply and without motor



! WARNING

Injury due to explosion of capacitors

If the unit has been stored for longer than two years, the DC link capacitors can explode during commissioning. Reform the DC link capacitors if the unit has been stored for longer than two years. Contact the factory to determine what measures must be taken.

Checking the connections

1. Check all the connections at the inverter.
 - Check whether all connections match the documentation.
 - For every control cable, check whether it is firmly connected.
2. Check whether the power connections have been connected with the correct torque.

Refer to the torques listed in the torque table in Chapter "Tightening torques for power cables (Page 201)".
3. Also check the internal power connections for units with more than 160 kW.

The connections can slacken during long transport.

Checking the applied voltages

1. Check what voltage is present at the control cable terminals of -A1-X2.
 - A voltage of 32 V to 250 V must only be present at the top green terminals and/or at terminal 37.
 - All other terminals must be supplied with a maximum voltage of 32 V.
2. Compare the mains voltage you will connect with what is stamped on the inverter type plate.
You will find detailed information in the following table.
3. For cabinet units, identifier 2T..-8....-..., also reconnect the fan transformer -T4 to the rated mains voltage and check whether the transformer is connected to the correct voltage.
 - Compact units, identifier 2T..-0....-..., supply the fans via the DC link.
 - Thus, there is no configuration work for you.

Table 7-1 Voltage range of the different device types

Device	Type designation according to rating plate	Mains voltage range
400 V compact unit	2T..-0.40.-...	230 V ... 500 V
400 V cabinet unit	2T..-8.40.-...	230 V ... 415 V
500 V unit	2T..-.50.-...	230 V ... 500 V
690 V unit	2T..-.69.-...	400 V ... 690 V

Hardware settings

- Set the DIL switches S1 and S2 as required.
You can find more detailed information in Chapter "DIL switches "S1" and "S2" (Page 149)".

Performing insulation test

1. Take the necessary safety precautions such as covering neighboring system parts etc.
2. Connect terminals U1, V1, W1, U2, V2, W2.

3. For compact devices, detach the internal yellow-green wire from the connection point for PE.

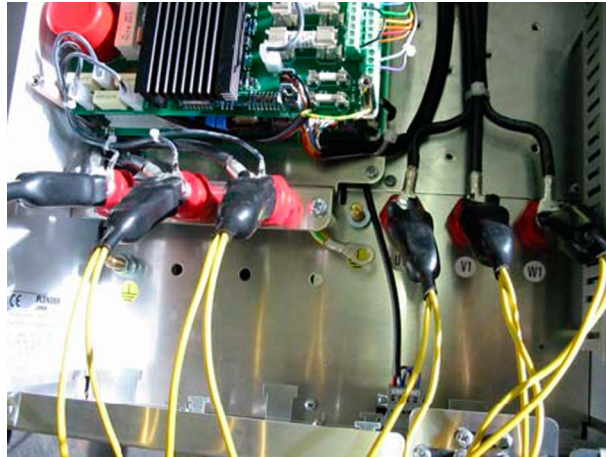

Figure 7-1 Insulation test

4. In the case of cabinet units, remove the "output filter" board -A9 or disconnect its ground connection.
5. You can find the board at motor terminals -X0:U2, V2, W2.
6. In the case of the "radio interference Class A" option, also disconnect the input side radio interference suppression capacitor -C10 from the line connection busbar at -X0:U1, V1, W1 or the main switch.
7. Perform the test with maximum DC 500 V for a maximum of 2 minutes between the U1, V1, W1, U2, V2, W2 jumper and the enclosure.
8. After completion of the test, connect the output voltages U, V, W with PE.
9. Undo the above actions.

7.2 Checks with mains power supply and without motor

The load-dependent actual values, e.g. "I-motor", "T-motor" or "P-motor" are also displayed without motor. They are 0 in this case.

- Perform the following tests and configurations without motor connection. This prevents damage to the motor in the case of errors.

If tests without motor are not possible, then perform the tests with motor.

- The "peripheral board 2 / 4" option which can be recognized from the last position of the type designation on the rating plate has safety-oriented inputs.

Check these inputs according to the description ""Safe torque off" with single circuit trip (Page 42)".

Selecting application and mode

- It is not necessary to select an application for inverters which have been fitted with a signal controller at the factory.
- The parameter assignment is adapted in the factory when the unit is being tested and is stored under menu "P-DRIVE DATA/A" in the "Factory parameters" application.
- Select the required application under "P-DRIVE DATA/A", and select the required operation mode under "P-OPERATION/Opr."
 - Use the associated wiring diagram in the Appendix for this. The "Standard" application is set as the default at the factory.
 - You can find additional information in Chapter ""Standard" application (Page 168)".
- If you would like to make other changes to the parameters, these changes can be made at this point.

In this case, parameter "P-DRIVE DATA/A = standard" changes to "P-DRIVE DATA/A = specific".

Note

Loss of all configured values

If you select other applications before the changed parameters have been saved, all values already set will be lost. Save the changed parameters before selecting other applications.

Checking mains voltage parameters

1. Set your rated mains voltage in menu item "P-INVERTER DATA/V mains nom."
If necessary, set the controller / fan transformer correctly.
2. You can find additional information in Chapter "Line supply connection (Page 93)".

Adapting motor data

1. Under "P-MOTOR DATA/" first set the closed-loop control version of the inverter or the "Motor type"

You can enter the following control variants:

- "asyn_SVC": Asynchron Space Vector Control, vector control
 - For applications that are not special, use standard three-phase motors suitable for inverter operation.
 - Use the rating plate data for parameterization purposes if the motor is to be operated with the inverter.
- "asyn_FOC": Asynchron Field Oriented Control, field-oriented control
 - For this function, use a tachogenerator directly on the motor shaft which meets the required conditions. You can find more detailed information in Chapter "Sub-D and USB connections and DIL switches (Page 148)".
 - The load machine and the required dynamics determine the maximum required impulses per revolution which the tacho should have.
 - Use at least 1,024 pulses / 360°. If you increase the dynamics, then also increase the number of impulses, e.g. to 2,048 or 4,096. Use a tacho with larger number of impulses for smaller flywheels.

Set the following parameters in the control version "asyn_FOC" under "P-MOTOR DATA/":

1. Under "/Motor type", set "asyn_FOC",
2. Select the tacho type used for "/Encoders".
3. Set the number of pulses per motor revolution under "/Pulses/360".
4. When entering the rating plate motor data, also set the precise motor no-load current under "/I idle".
 - Read the rated speed /n motor from the rating plate.
 - Specify the no-load current in the operating mode "asyn_SVC", in mains operation or ask the motor manufacturer for this value.
5. Always perform "Auto-Tuning".
6. Select the menu level "Expert" in order to reach the "P-CONTROL PARAMETER" menu item.
 - Adjust the optimum control behavior of your system for load change and speed change under "P-CONTROL PARAMETER".
 - In rated operation, set the values for "/P sp.ctr." and "/Tr sp.ctr.".

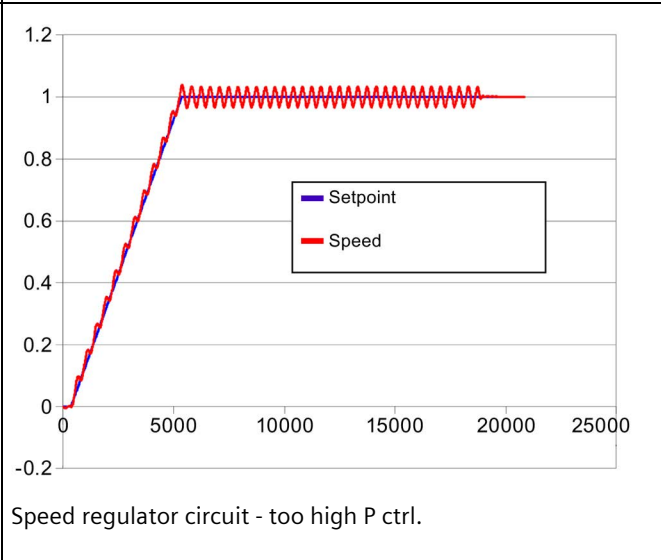
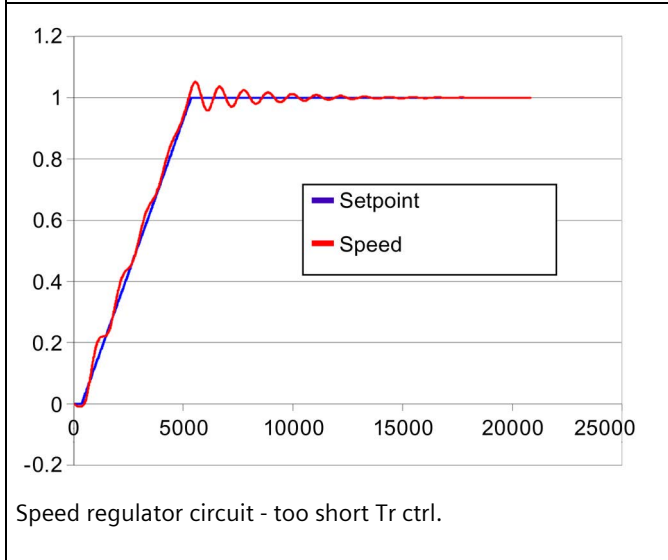
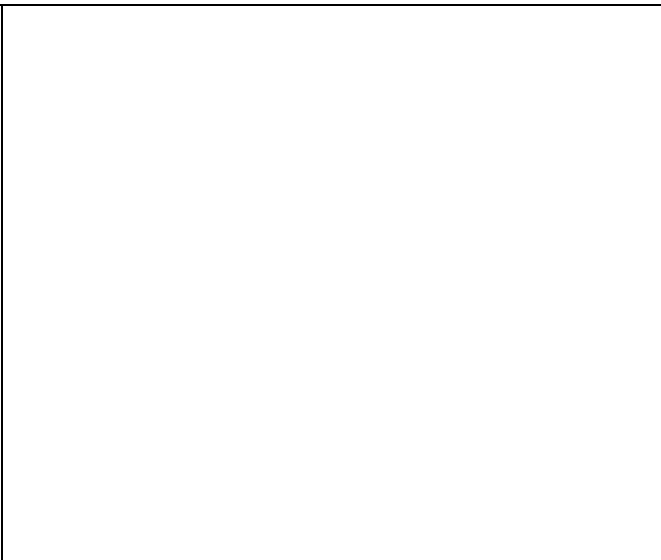
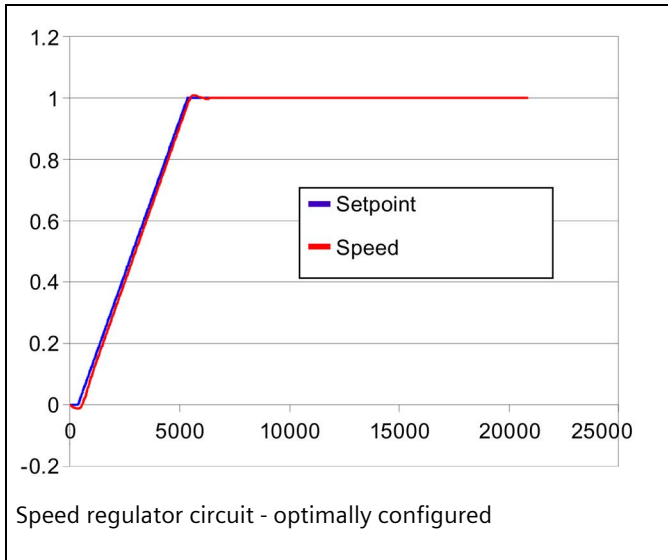

The following applies to all motors:

- Enter the rating plate parameters of the motor for sine mode.
- This data can be found on the motor rating plate.

Configuring drive data

Specify the speed limits and the direction of the output rotating field in the menu item "P-DRIVE DATA".

1. Determine the minimum output frequency of the rotating output field for a minimum setpoint value with the "/fmin" value. The "/fmax" value specifies the upper speed limit. More detailed information is provided in Chapter "Motor connection (Page 98)".
2. Set the rotation direction under "/Rotation":
 - "CW" or "CCW" specifies the rotary field as clockwise or counter-clockwise.
 - "Both" means that the rotary field depends on the polarity of the setpoint value and can be changed using the terminal block command "Reversing".
3. Set the rate of the speed default (speed setpoint) change under "P-SPEED DEFAULT/t-accel." and "P-SPEED DEFAULT/t-decel.".

Checking all inputs and outputs

1. Check whether signals arrive correctly at all inputs and outputs.

You can simulate all data except load-dependent data.
2. Under "P-EXTRAS/Menu" set the value for the menu level to "Standard", in order to increase the number of accessible parameters and thus be able to make further parameter adjustments.

7.3 Checks with mains power supply and with motor

Perform the following tests and configurations with an uncoupled motor. This prevents damage to the work machine in the case of errors. If test with uncoupled motor are not possible, perform the tests with coupled motor. However, increased caution is thereby required.

Performing auto tuning

You can match the connected motor to the inverter under "P-MOTOR DATA/Auto-Tuning".

- Select the "Yes" option and press the "Apply" button.
 - The inverter transmits a measurement signal to the motor.
 - Based on the measured values, the inverter calculates the instantaneous total resistance of the motor winding and motor feeder cable.

Checking the direction of rotation

1. Check the rotation direction at low speed directly at the motor.
2. In the case of "Rotation" = "both", check the direction for both directions of rotation.

Checking the vibration

1. Carry out slowly the complete speed control range. Observe the motor in doing so.
 - If vibrations occur at a certain speed, contact the motor manufacturer for advice. If required, you can suppress this frequency.
2. In menu "P-DRIVE DATA/fno1" and " P-DRIVE DATA/fno2", suppress two frequency bands with a minimum and a maximum value, which will then no longer be used by the drive under steady-state operating conditions.

7.4 Checking with motor coupled to the work machine

Perform the following tests with the driven machine.
The measurement should be taken at the highest possible output frequency and load.
Consult the factory fin the case of large difference.

Symmetry of mains and motor current

1. Measure the mains current and the motor current using a current clamp meter. The measured value deviates from the displayed value on the screen depending on the type and quality of the current clamp meter.
2. Ensure that the same current flows in all three mains power phases with a maximum deviation of 5% of the inverter rated current. You thus detect whether damaging imbalance of the mains voltage is present.
3. The same applies in all motor phases with a maximum deviation of 2%. In the case of cables laid in parallel, also check the current distribution to the individual conductors. Here, you recognize insufficiently clamped connections and also damage to the motor.

Checking load-dependent measured values

- Check the motor current with the couple work machine.
- Check whether the motor current on the display in stationary operation, i.e. without acceleration or braking, exceeds the motor current on the rating plate.

Documenting measured values, saving parameter file

Document all measured values from the commissioning in a measurement report and save the parameters of the inverter with the "IMS" software.

Operation

8.1 Operation

8.1.1 Function of the inverter display

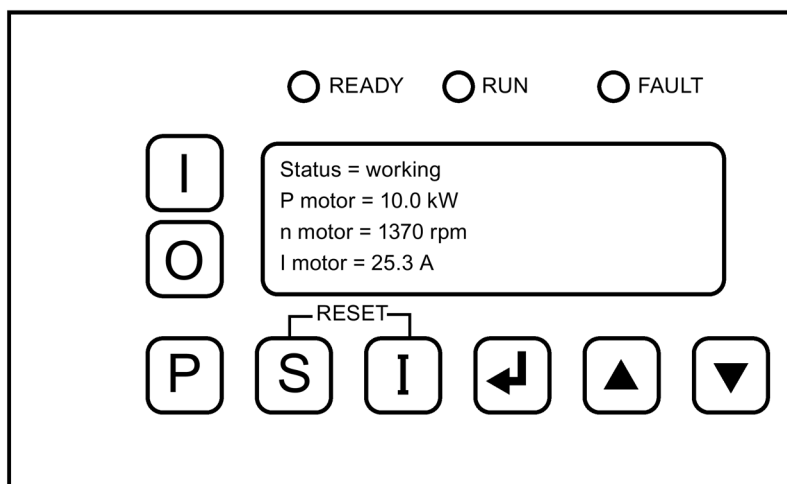

Figure 8-1 Inverter display

The display is used for operating and monitoring the inverter.









LEDs "READY", "RUN" and "FAULT" indicate the actual status of the inverter.

The following data can be read on the plain text display:

- The actual values of the inverter, e.g. motor current
- All parameters
- All stored error messages

The inverter is operated using the display buttons as follows:

Table 8-1 Inverter operation using the display buttons

	"Inverter On"
	"Inverter Off"
The buttons for "Inverter On" and "Inverter Off" are only active if you select the appropriate self-holding as "Operating source".	
	Use buttons <Arrow down> or <Arrow up> to navigate in the menu. You specify the speed setpoint by pressing the buttons twice. This function is only active if the setpoint has been set in the configuration. Use these buttons as well to select individual actual values such as, e.g. "n-Motor".
	You reach the actual values menu or one actual value menu level higher by pressing this button.
	Press the <Return> button to branch into a submenu to unlock a parameter so that it can be changed and then lock it again.
	If you press the <S> button, you return to the status display with the actual values.
	Acknowledge pending errors by pressing the <S+I> buttons simultaneously.
	Press <P> to enter the parameterization menu or to reach a higher parameter menu level.

8.1.2 Switching the unit on and off

Read the information in Chapter "Safety information (Page 13)" before you switch on the unit.

WARNING

Automatic startup

Depending on parameter settings and connection of external control devices, the inverter can start up automatically when the mains voltage is connected. The motor and coupled machine can start moving unexpectedly. This can result in death, serious injury or material damage.

Confirm whether or not your system is capable of automatic starting and, if appropriate, take measures to ensure personal safety and operational readiness at the driven machine.

Startup

1. If your inverter is supplied with an external control voltage from an external or auxiliary power supply, then switch this supply on first.
2. Switch on the line voltage.
3. Start up the inverter using the control command <On> or enter the On command via an external control device (if one is connected).

Shutdown

1. Stop the inverter using the control command <Off> or enter the Off command via an external control device (if one is connected).
2. If you want to isolate the inverter and bring it into a no-voltage condition, then disconnect the line supply and any connected external or auxiliary power sources.

8.1.3 Setting the language

The converter has two display languages.

1. Press <S> for approx. 2 seconds to switch the display language.
2. Press <S> again for approx. 2 seconds to switch back to the original display language.

This switchover is only temporary, and only acts until the supply voltage is switched off/on the next time.

You can apparently switch over the language using parameter *P-EXTRAS:Language*.

You can download further display languages using the PC tool "IMS":

1. Launch the PC tool "IMS" and connect the converter to the PC.
2. Select a language using the software "IMS" under "Online functions, Transfer language...".

Note

Loss of a display language

Every new display language transmitted to the converter overwrites one of the existing languages.

8.1.4 Setting the date and time

The correct device time facilitates faster troubleshooting.

Faults that occur in operation are saved to an event memory with the associated date and time.

Set the actual time and date under "P-EXTRAS/Date" or "Time".

- The current time of the testing date is set as CET at the factory.
- Winter and Summer time are not taken into account.

8.1.5 Setting the level of detail of the inverter menu

In menu "P-EXTRAS", set the level of detail of the inverter menu in order to change the number of visible menus and parameters, therefore increasing overall transparency.

8.1.6 Inverter operating commands

The converter is operated using various inputs, such as control cable terminal block inputs, control words via fieldbus, signal generators etc. Further information can be found under "Configuring operating sources (Page 128)"

The commands have the following functions:

- "Controller release"

The power unit in the converter, consisting of IGBTs, is only active when controller is enabled. As well as the options for releasing the controller by software, control cable terminal -A1-X2:8 must also be activated. If you deactivate this function, the output semiconductor is blocked immediately and the motor coasts to a stop.

- "Speed on"

Use this command for controlled shutdown of a motor. The motor passes through a brake ramp during shutdown. The converter is immediately ready for a restart after the braking.

- "Reset"

Acknowledge an active error using the "Reset" command. The converter also takes into account a shutdown using functions "Emerg. stop" or "Off1" and "Off2".

- "Off1 (NC)" and "Off2 (NC)"
 - Initiate controlled braking with the "Off1" command. This command is initiated by software. Initiate an immediate block with the "Off2" command. An optional main contactor drops out. Acknowledge the converter before restarting using the "Reset" command. When restarting, the converter must first be pre-charged.
 - Controlling "Off1" and "Off2" via the control cable terminal strip is realized using an NC (normally closed) contact.
- "Emerg. stop (NC) OFF3"
 - Initiate controlled braking along the "Emerg. stop braking ramp" with the "Off3" command. This command is initiated by software. The converter shuts down after braking. An optional main contactor drops out. Acknowledge the converter before restarting using the "Reset" command.
 - Controlling "Emerg. stop (NC)" via the control cable terminal strip is realized using an NC contact.

This function is not safety-related in the sense of DIN EN ISO 13849-1:2015. If you must realize a safety-relevant "Emerg. stop" function according to IEC/EN 60204, stop category one, then control this input and a main contactor via an appropriate safety relay, e.g. type 3TK2827... from Siemens.

 **WARNING**

Non-safety-related "Emerg. stop (NC) OFF3" function

If you use the "Emerg. stop (NC) OFF3" function without an additional safety relay in the input and for a main contactor, then the motor will not be shut down in a safety-related way. This can result in death, serious injury or material damage.

For a safety-related "Emergency stop" function according to IEC/EN 60204, stop category one, use a safety relay for the input and main contactor, e.g. type 3TK2827....

- "int.ctrl.inhib."

If you have realized the operating functions using controls, e.g. ON / OFF button, this command causes a shutdown using controller lock without deactivating the controls. No new ON command is necessary for the restart.
- "int. speed off"

This command has the same function as "int. controller inhibit"; however, it results in controlled braking down to zero speed. All controls are maintained.

- "Reversing"
 - If you enter value "both" in menu item "P-DRIVE DATA/Rotation", then you can activate the "Reversing" command. When activated, the converter changes the rotating output field. In doing so, the motor is braked in a controlled way on the brake ramp to zero speed. Afterwards, it is accelerated to the configured setpoint value in the opposite direction. If the value "both" is not set, the drive goes to the configured minimum speed.
 - If the drive does not start despite the presence of setpoint value and operating commands, check whether the reverse function is activated and at the same time only one rotation direction is enabled.

- "Motor potentiometer"

Similarly to a mechanical motor potentiometer, you can change the setpoint value using the <up arrow> and <down arrow> buttons. The position of the motor potentiometer is stored in the case of power failure.

8.1.7 Configuring operating sources

- Assign the functions mentioned above to the desired operating source.
 - You can configure operating sources for "Local" using internal display, "Remote", using control cable terminal strip -X2 and "Bus".
- Using command "Op.-source" in menu "P- INTERFACE/Op.-source", set your preselection for the on-off commands.
- If you wish to toggle between "Local" and "Remote", then initiate the switchover using a completed configuration under "P-OPERATION/Opr.", or change the setting "P-PARAMETER SWITCH".
- Select the Reset source for the Reset command under "P-INTERFACE".
 - If you would like to activate the reset independently of the operating source changeover, then set "Global". The reset is then possible at all operating sources.

8.1.8 Invoking mode configurations

Call the completed operating configuration under "P-OPERATION/Opr.". Settings for the controls and the parameter switches are automatically made in these configurations.

For each selection, there is an associated connection plan and a specified mode of functioning of the display buttons and digital inputs. You can find additional details in Chapter "Standard mode settings (Page 135)".

Changes in menu "P-OPERATION/" result in the addition of "spec." under "P-OPERATION/Opr." as information that something has been changed from the default setting.

8.1.9 Communication Options

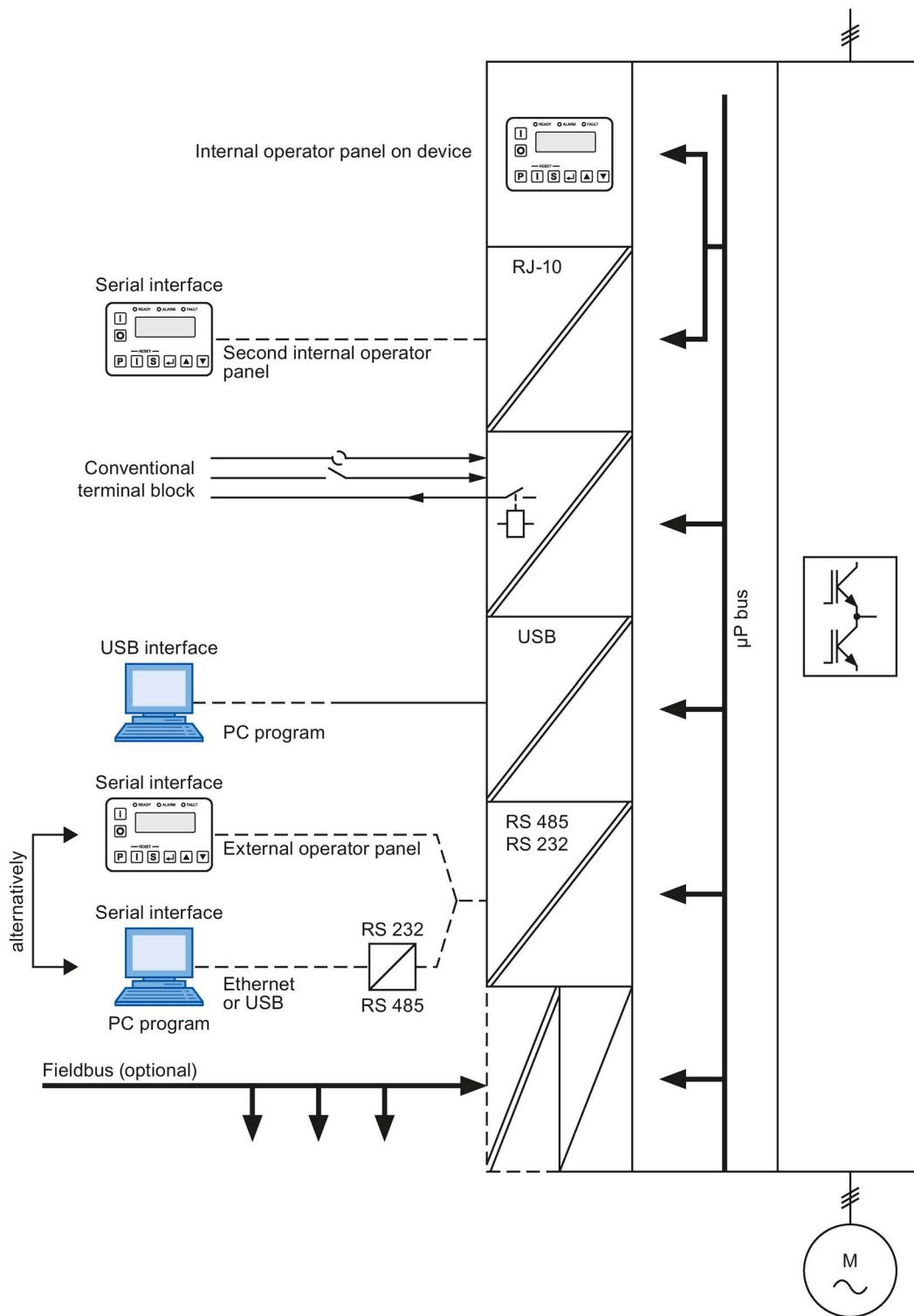

Figure 8-2 Communication Options

8.1.10 Meaning of the abbreviations for operating functions

The following abbreviations exist for the operating options of "Controller block" and "Speed On" via display or control cable terminal block:

- "siss"
- "sisd"
- "dids"
- "didd"

The letters have the following meanings:

- "s" designates the static setting. The default for "On" is performed via a permanent contact.
- "d" designates the dynamic setting. The defaults for "On" and "Off" are performed via an On-button or Off-button.
- "i" designates the internal display. The operation is performed using the <On> and <Off> buttons.

The individual positions in the abbreviation have the following meaning:

1st position: Controller block for "local", e.g. "s" for static via control cable terminal block

2nd position: Speed On for "local", e.g. "i" for internal display via <On> and <Off> buttons

3rd position: Controller block for "remote", e.g. "s" for static via terminal block

4th position: Speed On for "remote", e.g. "d" for dynamic via control cable terminal block

You can change the operating source from "local", this corresponds to the inverter display, to "remote"; this in turn corresponds to control cable terminal strip -X2. To do this, apply a voltage of 24 V to the terminal -X2:12.

The operation settings "Namur 1" to "Namur 6" designate the different variations of the operation options according to the NAMUR specification.

8.1.11 "P-fieldbus" function

You select the basic fieldbus settings using the parameters in menu "P-fieldbus". Using "Rct. BUS" and "Time-out t", you set whether the converter should respond when the fieldbus connection is interrupted - and if it should, then after which time.

Additional notes are provided in Chapter "Optional fieldbus connection (Page 56)".

8.1.12 "P-DIGITAL OUTPUTS" function

The inverter provides at least four relays and two LEDs. In the "P-DIGITAL OUTPUTS" menu, you can select the signal which should actuate the respective relay or LED from a list ("Bitpool"). More outputs might be available depending on the variants and quantity of installed power sections.

8.1.13 "P-ANALOG OUTPUTS" function

The inverter has two electrically isolated analog outputs. Depending on the type of connected measuring instrument, the output signal is automatically set to a +20 mA current source or to a +10 V voltage source. Input the following in the "P-ANALOG OUTPUTS" menu:

- Which signals should be output?
- What is the full scale value of your display instrument?
- Should a 4 mA addition or a different value be added?
- Should a center point increase be output for the presentation of bipolar signals?

8.1.14 Operation of several inverters on one PC

It is possible to operate several inverters simultaneously with one PC using the PC tool "IMS". This is possible either via the RS 485 serial interface or the optional PROFIBUS or PROFINET fieldbus interfaces.

- For RS 485:
You require an appropriate interface converter from Ethernet or USB to RS 485, and you must establish an RS 485 bus connection between the relevant inverters (-X51) and the interface converter. You must set the baud rate for all devices to the same value, and the participant address of the inverter to different values ≥ 3 .
You must be able to access the interface converter via the Ethernet network or it must be connected to the PC via USB.
- For PROFIBUS:
You require the appropriate interface converter from Ethernet or USB to PROFIBUS (manufacturer: Softing) and you must connect this with the relevant PROFIBUS line. You must set your control system for this PROFIBUS line so that you accept an additional Class 2 master in the communication.
When establishing the connection, the interface inverter must be set to a free bus address and the given baud rate.
- For PROFINET:
You must establish a bus connection between the relevant inverters (via port 1 or port 2 of the particular PROFINET board) and the Ethernet interface of the PC. All participants must have a unique IP address and be located in the identical subnet.

8.1.15 Communication via PROFINET IO

8.1.15.1 Communication services and port numbers used for PROFINET IO

The PROFINET boards of the SINAMICS G180 converter support the communication protocols listed in the following table.

You require this information to match the security measures (e.g. a firewall) to protect the automation system to the protocols being used.

Layers and protocols

Report	Port number	(2) Link layer (4) Transport layer	Description
PROFINET protocols			
DCP Discovery and Configuration Protocol	Not relevant	(2) Ethernet II, Ethertype 0x8892	DCP is used by PROFINET to determine PROFINET devices and to facilitate the basic fundamental settings. DCP uses the special Multicast-MAC address: 01-0E-CF-00-00-0x, whereby x = 0: Identify and x = 1: Hello
LLDP Link Layer Discovery Protocol	Not relevant	(2) Ethernet II, Ethertype 0x88CC	LLDP is used by PROFINET to determine and manage relationships between the various PROFINET devices. LLDP uses the special Multicast-MAC address: 01-80-C2-00-00-0E
MRP Media Redundancy Protocol	Not relevant	(2) Ethernet II, Ethertype 0x88E3	MRP facilitates the control of redundant communication paths through a ring topology. MRP uses the special Multicast-MAC address: 01-15-4E-00-00-0x, whereby x = 1: MC_Test and x = 2: MC_Control
PROFINET IO data	Not relevant	(2) Ethernet II, Ethertype 0x8892	PROFINET IO-telegrams are used to transfer IO data cyclically between PROFINET IO-Controller and IO-Devices via Ethernet.
PROFINET RT Unicast	34962	(4) UDP	For PROFINET RT Unicast, the data packets to be sent are sent to an individual participant.
PROFINET RT Multicast	34963	(4) UDP	For PROFINET RT Multicast, the data packets to be sent are sent to a group of participants.
PROFINET Context Manager	34969	(4) UDP	The PROFINET Context Manager provides a Endpoint-Mapper to establish an application relationship (PROFINET AR).
PROFINET RPC Remote Procedure Call	53247	(4) UDP	The PROFINET RPC manages acyclic communication messages, which are received via UDP.

Report	Port number	(2) Link layer (4) Transport layer	Description
Internet protocols			
FTP File Transfer Protocol	20 21	(4) TCP	This protocol allows access to the FTP Server of the PROFINET board.
DHCP Dynamic Host Configuration Protocol	67 68	(4) UDP	This protocol facilitates the assignment of the network configuration to the Clients through a Server.
http Hypertext Transfer Protocol	80	(4) TCP	This protocol allows access to the Web Server of the PROFINET board.
SNMP Simple Network Management Protocol	161	(4) UDP	This protocol allows network management data to be read out and set.
ARP Address Resolution Protocol	Not relevant	(2) Ethernet II, Ethertype 0x0806	This protocol allows the physical address of the network access layer to be determined for a network address of the Internet layer.
SMTP Simple Mail Transfer Protocol	49152	(4) UDP	This protocol allows the PROFINET board to send emails.
SNTP Simple Network Time Protocol	123	(4) UDP	This protocol allows the clock, integrated in the converter, to synchronize with a time server.
Secure HICP Secure Host IP Configuration Protocol	3250	(4) UDP	This protocol allows the Anybus IPconfig Utility to change settings of the PROFINET board, for example the IP address, the subnet mask or deactivate/activate DHCP.
Internal protocol	3001 (default) 1024 - 3149 (can be parameterized)	(4) TCP	This protocol allows communication to be established between the PROFINET board and the Inverter Management Software.

8.1.15.2 Overview



Network security includes all measures taken to plan, implement and monitor security in networks. This includes the control of all interfaces, e.g. between the office network and plant network, or remote maintenance access via the Internet.

8.1.15.3 Network security

SINAMICS must only be used in a secure and trustworthy network with a firewall. Note the information in chapter "Network segmentation (Page 135)".

8.1.15.4 Separation between production and office networks

One important protective measure for your automation or drive system is the strict separation of the production networks and the other company networks. This separation creates protection zones for your production networks.

Note

The products described in this manual must only be operated in defined protection zones.

Separation by means of a firewall system

In the simplest scenario, separation is achieved by means of an individual firewall system which controls and regulates communication between networks.

Separation via a DMZ network

In the more secure variant, the coupling is established via a separate DMZ (demilitarized zone) network. In this case, direct communication between the production network and the company network is completely prevented by firewalls and only takes place indirectly via servers in the DMZ network.

Note

The production networks should also be divided into separate automation cells in order to protect critical communication mechanisms.

General security measures

Adhere to the general security measures even within protection zones, e.g. the use of a virus scanner or the reduction of points of attack.

8.1.15.5 Network segmentation with SCALANCE S

Siemens provides SCALANCE S security modules to meet network protection and network segmentation requirements. These are modules support various security functions.

Further information on SIEMENS SCALANCE S can be found on the Internet (<https://www.siemens.com/global/en/products/automation/industrial-communication/scalance.html>).

Note

Data misuse

Long distances between the device to be protected and the upstream security modules represent an invitation for data misuse.

Upstream security modules, such as SCALANCE S, must be installed close to the device to be protected in a locked control cabinet. This ensures that data cannot be manipulated here without being observed.

8.2 Standard mode settings

8.2.1 Operation "std siss"

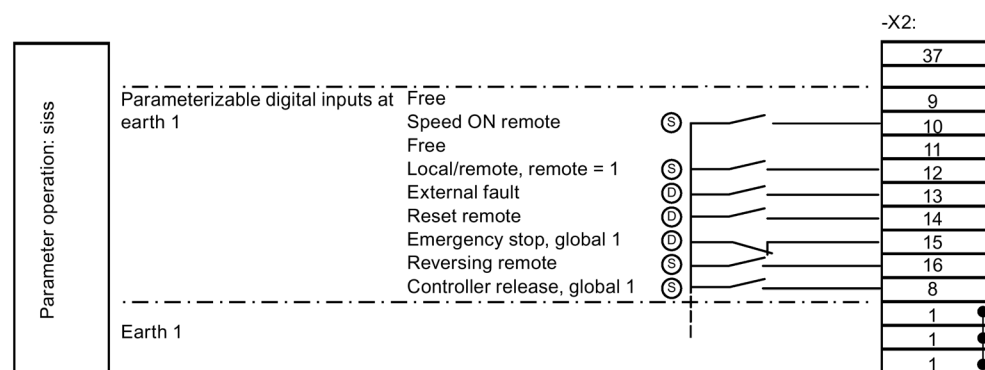

(D) Dynamic: Pushbutton mode

(S) Static: Switch mode

Figure 8-3 Assignment of the control cable terminals for operation "std siss"

Control behavior for "Local" (dynamic)

- Enter commands "Speed On" and "Speed Off" using the <On> and <Off> buttons on the display.
- Make the setpoint value setting using the <down arrow> and <up arrow> buttons.
- Reset errors by pressing the buttons <S+I> simultaneously.

Control behavior for "Remote" (static)

- Control the operation of "Speed on" using a switch at -X2:10.
- Enter the setpoint via control cable terminal block -X2 with analog setpoint value 1.
- When required use the reversing input -X2:16.

"Local" and "Remote" operation

- "Emergency stop (NC)": If you open the contact at -X2:15, the drive decelerates down to 0 speed along the braking ramp for an emergency stop. The inverter clears all self-holding (latching) functions.
- "Reset" (NO): Reset errors and "Emergency stop" using a 24 V pulse at -X2:14.
- "Controller release, static" (NC) -X2:8: Enable the inverter using a permanent contact. The drive coasts to a stop if you open the contact. The inverter clears all self-holding (latching) functions.

8.2.2 Operation "std sisd"

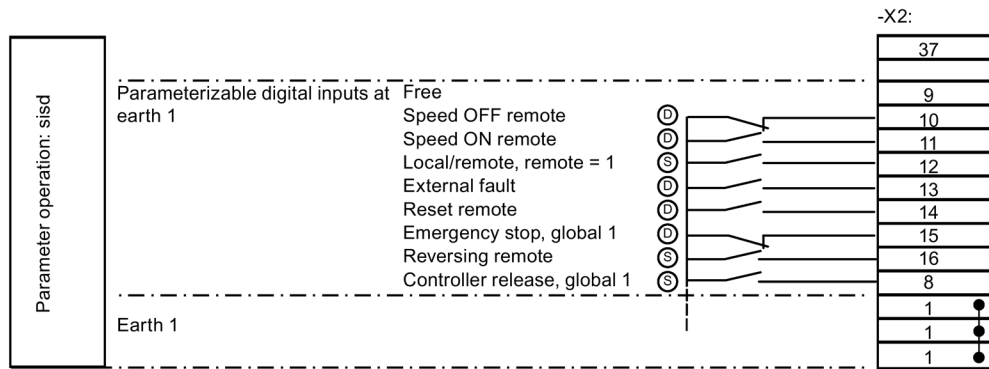

- (D) Dynamic: Pushbutton mode
- (S) Static: Switch mode

Figure 8-4 Assignment of the control cable terminals for operation of "std sisd"

Operation different from "std siss"

The operation "Speed On" for "Remote" operation is dynamic.

Start the drive with an NO (normally open) contact at -X2:11. You change the inverter speed to 0 with an NC (normally closed) contact at -X2:10.

8.2.3 Operation "std dids"

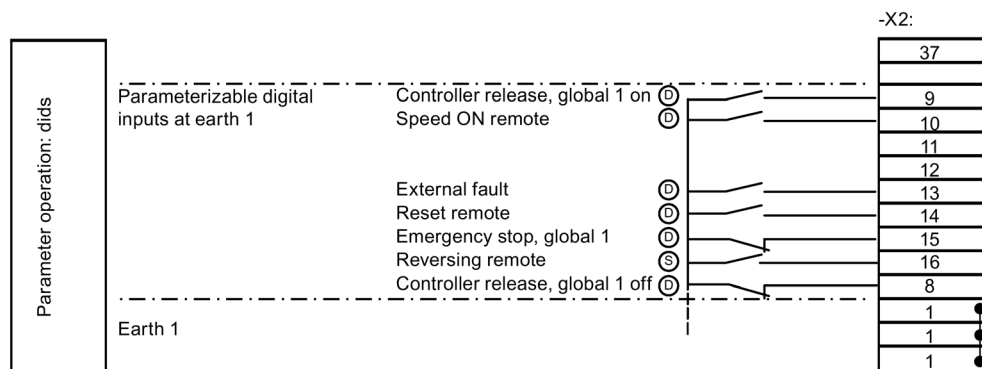

(D) Dynamic: Pushbutton mode

(S) Static: Switch mode

Figure 8-5 Assignment of the control cable terminals for operation "std dids"

Control behavior for "Local" (dynamic)

- Enter the command "Speed On" and "Speed Off" using the <On> and <Off> buttons on the display.
- Make the setpoint value setting using the <down arrow> and <up arrow> buttons.
- Reset errors by pressing the buttons <S+I> simultaneously.

Control behavior for "Remote" (static)

- Control the operation of "Speed on" using a switch at -X2:10. Enter the setpoint via control cable terminal block -X2 with analog setpoint value 1.
- When required use the reversing input -X2:16.

"Local" and "Remote" operation

- "Emergency stop (NC)": If you open the contact at -X2:15, the drive decelerates down to 0 speed along the braking ramp for an emergency stop. The inverter clears all self-holding (latching) functions.
- "Reset" (NO): Reset errors and "Emergency stop" using a 24 V pulse at -X2:14.
- "Controller release dynamic": Enable the inverter using a normally open contact at -X2:9. The drive coasts to a stop if you open the contact at -X2:8. The inverter clears all self-holding (latching) functions.

8.2.4 Operation "std didd"

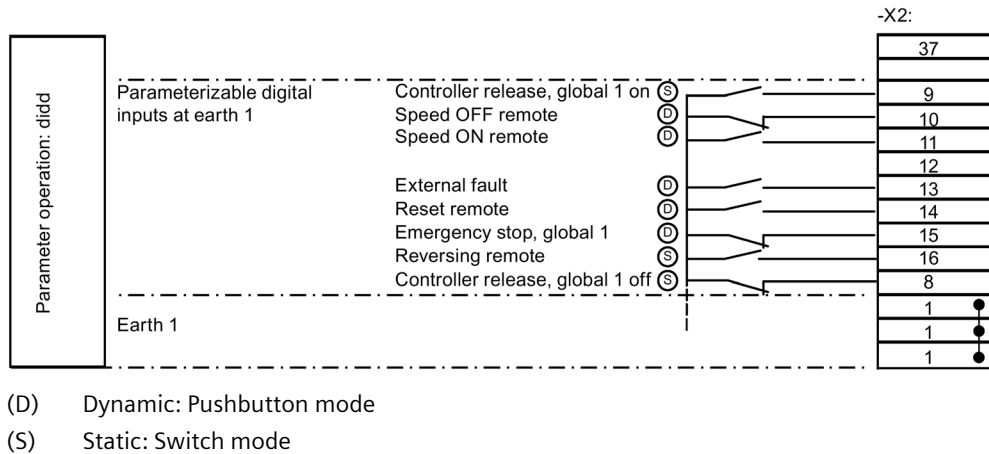

Figure 8-6 Assignment of the control cable terminals for operation "std didd"

Operation different from "std didd"

The operation "Speed On" for "Remote" operation is dynamic.

Start the drive with an NO (normally open) contact at -X2:11. Change the inverter speed to 0 with an NC (normally closed) contact at -X2:10.

8.3 NAMUR mode settings

8.3.1 Operation according to NAMUR defaults

If you activate the control cable terminal -X2:9 with 24 V, then the operation source and the setpoint input are switched from "Test" to "Normal" using a parameter switch.

You can connect the up and down buttons of a motor potentiometer function to control cable terminals -X2:12 and -X2:13. If you wish to use the motor potentiometer, under "P-PARAMETER SWITCH/P-ParamSwitch 11/AV" set the alternative value to "MPoti". The motor potentiometer function is now valid in "Normal" operation and not valid in test operation.

"Reset" (NO): Reset faults and "Emerg. stop" using a 24 V pulse at -X2:14

8.3.2 Operation according to "Namur 1"

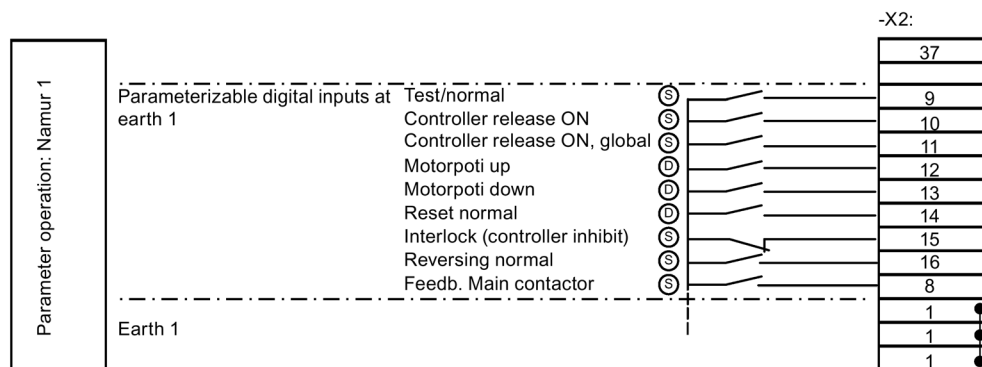

(D) Dynamic: Pushbutton mode

(S) Static: Switch mode

Figure 8-7 Assignment of the control cable terminals for "Namur 1" operation

Control behavior for "test" (dynamic)

- Enter the command "Controller release" and "CTRL.OFF" using the <On> and <Off> buttons on the display.
- Make the setpoint value setting using the <down arrow> and <up arrow> buttons.
- Reset errors by pressing the buttons <S+l> simultaneously. The locking and the OUT input on the control cable terminal block reset the control.

Control behavior for "normal" (static)

- Control the operation of the controller release with a switch (NO) at -X2:10. Enter the setpoint via control cable terminal block -X2 with analog setpoint value 1.
- When required use the reversing input (NO) -X2:16.

"Test" and "Normal" operation

- "Interlocking" (NC): The controller inhibit is activated if you open the contact at -X2:15. The drive coasts to a stop and cannot be restarted. "Interlocking" is shown on the inverter display.
- "Off" (NC): You activate the controller inhibit if you remove the 24 V signal at -X2:11.

8.3.3 Operation according to "Namur 2"

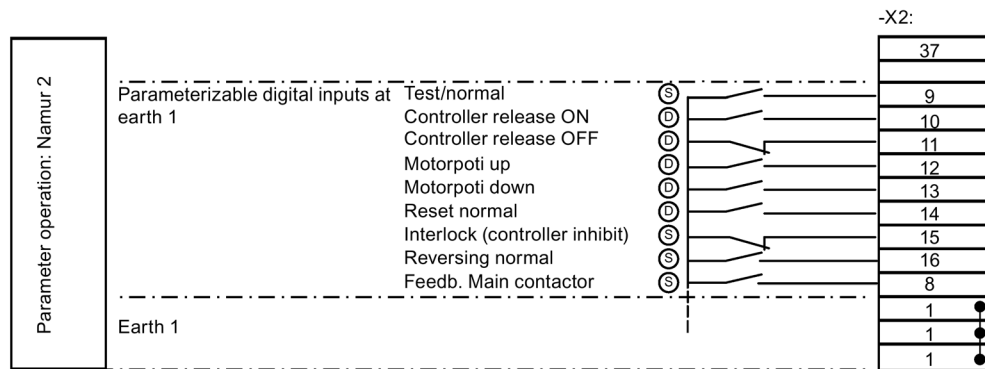

Figure 8-8 Assignment of the control cable terminals for "Namur 2" operation

Operation different than "Namur 1"

The operation of the controller inhibit for "Normal" operation is dynamic.

- Start the drive with an NO (normally open) contact at -X2:10.
- You inhibit the inverter with a normally closed contact at -X2:11.

8.3.4 Operation according to "Namur 3"

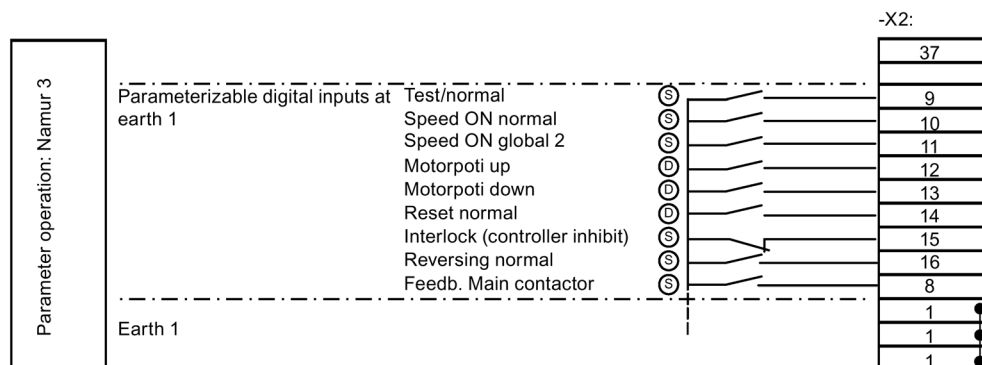

(D) Dynamic: Pushbutton mode

(S) Static: Switch mode

Figure 8-9 Assignment of the control cable terminals for "Namur 3" operation

Control behavior for "test" (dynamic)

- Enter the commands "Speed On" and "Speed Off" using the <On> and <Off> buttons on the display.
- Make the setpoint value setting using the <down arrow> and <up arrow> buttons.
- Reset errors by pressing the buttons <S+l> simultaneously. The locking and the OUT input on the control cable terminal block reset the control.

Control behavior for "normal" (static)

- Control the operation of the speed with a switch (NO) at -X2:10. Enter the setpoint via control cable terminal block -X2 with analog setpoint value 1.
- When required use the reversing input (NO) -X2:16.

"Test" and "Normal" operation

- "Interlocking" (NC): The controller inhibit is activated if you open the contact at -X2:15. The drive coasts to a stop and cannot be restarted. "Interlocking" is shown on the inverter display.
- "Off" (NC): You issue the command for "Speed Off" if you remove the 24 V signal at -X2:10.

8.3.5 Operation according to "Namur 4"

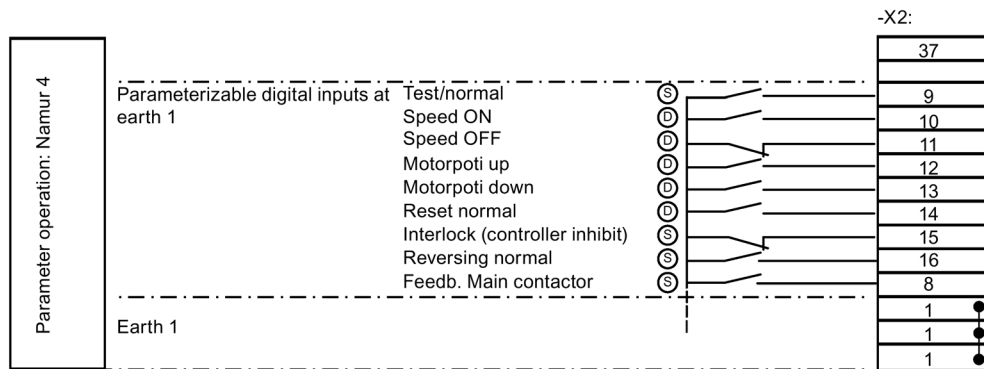

(D) Dynamic: Pushbutton mode

(S) Static: Switch mode

Figure 8-10 Assignment of the control cable terminals for "Namur 4" operation

Operation different than "Namur 3"

The operation "Speed On" for "Normal" operation is dynamic.

- Start the drive with a normally open contact at -X2:10.
- Issue the command "Speed Off" using an NC contact at -X2:11.

8.3.6 Operation according to "Namur 5"

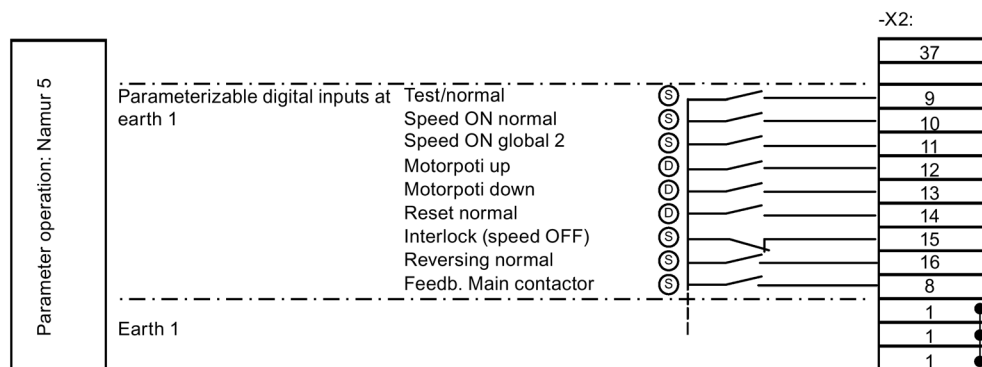

- (D) Dynamic, button mode
 (S) Static, switch mode

Figure 8-11 Assignment of the control cable terminals for "Namur 5" operation

Control behavior for "test" (dynamic)

- Enter the commands "Speed On" and "Speed Off" using the <On> and <Off> buttons on the display.
- Make the setpoint value setting using the <down arrow> and <up arrow> buttons.
- Reset errors by pressing the buttons <S+l> simultaneously.

Control behavior for "normal" (static)

- Control the operation of the speed with a switch (NO) at -X2:10. Enter the setpoint via control cable terminal block -X2 with analog setpoint value 1.
- When required use the reversing input (NO) -X2:16.

"Test" and "Normal" operation

- "Interlocking" (NC): The controller inhibit is activated if you open the contact at -X2:15. The drive coasts to a stop and cannot be restarted. "Interlocking" is shown on the inverter display. If the contact is closed again, you must restart the inverter in the test mode.
- "Off" (NC): You issue the command for "Speed Off" if you remove the 24 V signal at -X2:10.
- If you close the contact "Interlocking" or "Off" again during the braking phase, the drive accelerates immediately to the set setpoint value.

8.3.7 Operation according to "Namur 6"

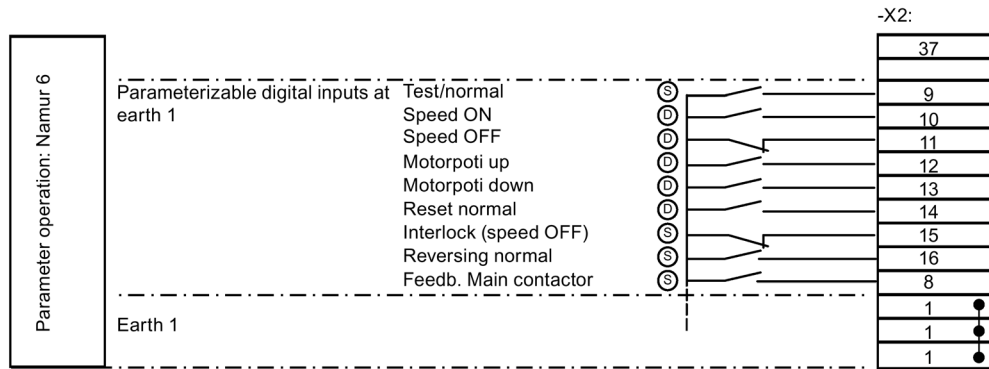

(D) Dynamic: Pushbutton mode

(S) Static: Switch mode

Figure 8-12 Assignment of the control cable terminals for "Namur 6" operation

Operation different than "Namur 5"

The operation "Speed On" for "Normal" operation is dynamic.

- Start the drive with a normally open contact at -X2:10.
- Issue the command "Speed Off" using an NC contact at -X2:11.

8.4 Controlling the external connections of the inverter

8.4.1 Function of the control cable terminals



Figure 8-13 Control cable terminals

The control cable terminals are used to connect control cables for exchanging signals. For more detailed information about the function of control cable terminals, refer to Chapter "Standard mode settings (Page 135)". The function of the control cable terminals, with the exception of input -X2:8 for hardware shutdown, is dependent on the parameterization.

8.4.2 Protective separation according to EN 61800-5-1



! WARNING

High voltages

If you connect peripheral devices which do not conform to this insulation concept, equipment damage might occur as a result of inadequate insulation. This can result in death, serious injury or material damage.

Connect devices and cables to the control cable terminals only if they conform to the relevant voltage class (DVC) described in this section.

8.4 Controlling the external connections of the inverter

Control and power circuits have protective separation between them according to EN 61800-5-1. The following graphics show the principle structure:

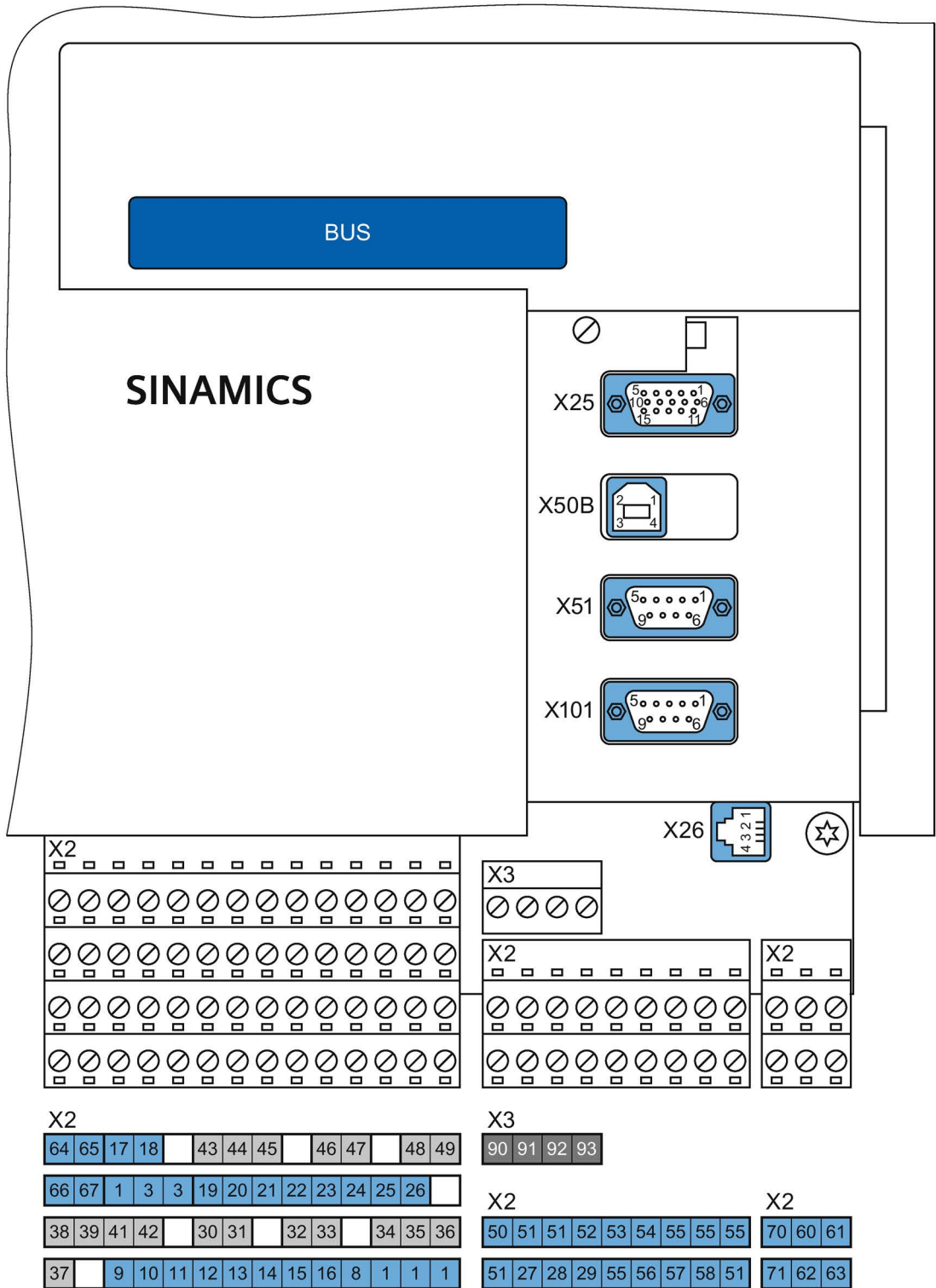
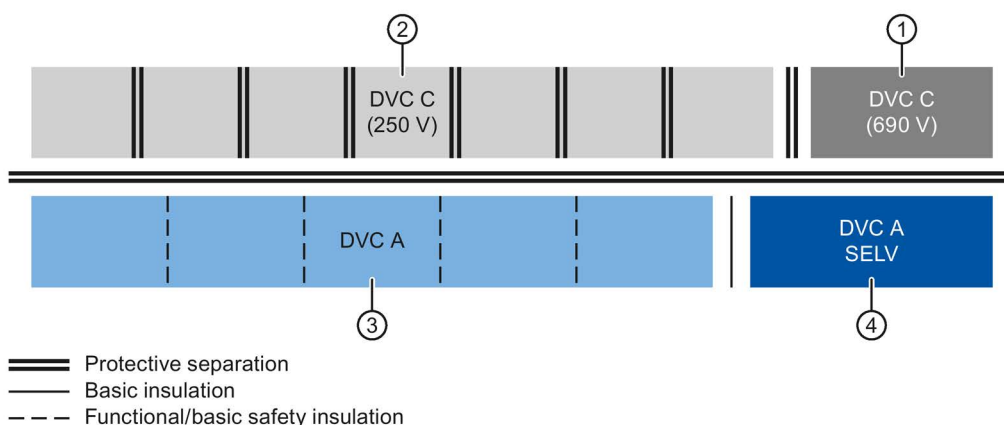

Figure 8-14 Overview of external connections and voltage classes



- | | | |
|---|---|-------|
| ① | Potential for output (PTC) (-X3) max. 690 V | DVC C |
| ② | Potential for digital outputs (-X2:37-42) max. 250 V | DVC C |
| | Potential for digital outputs (-X2:30,31) max. 250 V | DVC C |
| | Potential for digital outputs (-X2:32,33) max. 250 V | DVC C |
| | Potential for digital outputs (-X2:34-36) max. 250 V | DVC C |
| | Potential for digital outputs (-X2:43-45) max. 250 V | DVC C |
| | Potential for digital outputs (-X2:46-47) max. 250 V | DVC C |
| | Potential for digital outputs (-X2:48-49) max. 250 V | DVC C |
| ③ | Potential for digital inputs (-X2:1-26) | DVC A |
| | Potential for ETV (ETV = input isolating amplifier, analog inputs -X2:27-29,50-58, HTL tachometer -X101) | DVC A |
| | Potential for ATV (output isolating amplifier, analog outputs -X2:60-67,70-71) | DVC A |
| | Potential for control electronics/CB08 (inverter electronics, ext. Display -X26, sin/cos-tacho -X25, USB-B -X50B) | DVC A |
| | Potential for RS485 (ext. display/RS232 -X51) | DVC A |
| ④ | Potential SELV, safety extra-low voltage in accordance with EN 60950-1 (BUS circuit boards) | DVC A |

Figure 8-15 Insulation concept

DVC (Decisive Voltage Class) is the classification of the voltage range used to determine protective measures against electric shock hazards

Table 8-2 Limit values of the DVC according to EN 61800-5-1

DVC	Working voltage limits		
	Alternating voltage (rms value)	Alternating voltage (peak value)	Direct voltage (average value)
A	25 V	35,4 V	60 V
B	50 V	71 V	120 V
C	1.000 V	4.500 V	1.500 V
D	> 1.000 V	> 4.500 V	> 1.500 V

See Chapter "Technical data of the control cable terminals (Page 201)" for more detailed information on the control cable terminals.

8.4.3 Sub-D and USB connections and DIL switches

The following illustration clarifies the position of the Sub-D connections and DIL switches.

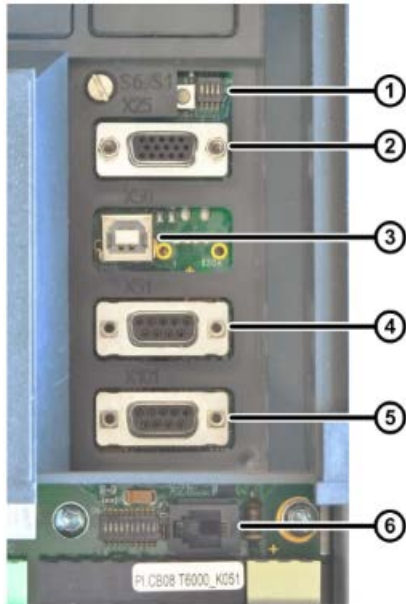

- ① S1.1 ... S1.4: Hardware setting
- ② -X25: SIN-COS/TTL speed encoder
- ③ -X50B: USB for PC with software "IMS":
- ④ -X51: RS 485 for an external operator panel In addition, it is also possible to communicate at this interface via RS 232, e.g. with "IMS".
- ⑤ -X101: HTL speed encoder
- ⑥ -X26: Additional RS 485 interface, not isolated. This is the standard interface for connecting the external operator panel (for local installation in the cabinet door only).

Figure 8-16 Interfaces at the converter

8.4.4 USB interface

 CAUTION
<p>Non-isolated USB interfaces</p> <p>The USB interface -X50B is not electrically isolated. The connection of a grounded device can cause an equipment or converter defect and consequentially pose the risk of physical injury.</p> <p>Devices that are connected, e.g. laptop with IMS, must have basic insulation between the USB interface and ground. In this case, the devices must offer this option, e.g. suitable for battery operation or the original power supply without ground connection.</p>

<p>NOTICE</p>
<p>No supply with a power source of limited output</p> <p>When the connected device is overloaded, the USB interface can develop defects. The equipment will be damaged as a result.</p> <p>The USB interface is a service interface only and not a general IT data interface in accordance with standard IEC/EN/UL 60950-1.</p>

8.4.5 DIL switches "S1" and "S2"

Switch "S1"

Table 8- 3 Functions - DIL switch "S1"

Switch	Function	Factory setting
S1:1	ON: configuration possible OFF: parameterization blocked	1
S1:2	ON: general fault in the open-circuit principle, OFF: general fault in the closed-circuit principle, control cable terminals -X2:34 ... 36	0
S1:3	ON: Complete initialization OFF:	0
S1:4	ON: flashing in conjunction with S1:3 = ON OFF:	0

Note

Remote flashing

DIL switches S1:1 and S1:4 must be set to "ON" for remote flashing.

Switch "S2"



- ① Gray cover
- ② -X26 for an external operator panel
- ③ Control cable terminal block -X2

Figure 8-17 DIL switch "S2"

The first four switches, S2: 1 / 2 / 3 / 4, define the voltage range for analog input 2, control cable terminal -X2:54:

Table 8-4 DIL switch "S2" - can be used to set the voltage range

S2: 1 2 3 4	Voltage range -X2:54
0 0 0 1	0 V ... ± 250 V
0 0 1 0	0 V ... ± 132 V
0 1 0 0	0 V ... ± 72 V
1 0 0 0	0 V ... ± 50 V
0 0 0 0	0 V ... ± 10 V

Switch S2: 5 / 6 / 7 configures the analog input AI 2 as a current/voltage input, PTC thermistor input, KTY84-130 input or PT100 input.

Table 8-5 DIL switch "S2" - possible settings for AI 2

S2: 5 6 7	Function	Control cable terminal
1 X 0	Current input	-X2:53 - -X2:51
0 0 0	PTC thermistor input	-X2:53 - -X2:51
0 1 0	KTY84 130 input	-X2:53 - -X2:51
0 1 1	PT100 input	-X2:53 - -X2:51
X X X	Voltage input	-X2:54 - -X2:51

Switch S2: 8 / 9 / 10 configures the analog input AI 1 as a current/voltage input, PTC thermistor input, KTY84-130 input or PT100 input.

Table 8- 6 DIL switch "S2" - possible settings for AI 1

S2: 8 9 10	Function	Control cable terminal
1 X 0	Current input	-X2:50 - -X2:51
0 0 0	PTC thermistor input	-X2:50 - -X2:51
0 1 0	KTY84 130 input	-X2:50 - -X2:51
0 1 1	PT100 input	-X2:50 - -X2:51
X X X	Voltage input, only 0 V ... \pm 10 V	-X2:52 - -X2:51

8.4.6 Connecting encoders

An encoder is required for field-oriented control only, the standard control works without an encoder.

Note

Unwanted operating state

If you do not connect up the encoder cables correctly, the loss of the encoder signal can give rise to unwanted operating states in the inverter control system.

Connecting a sincos encoder to -X25

All encoder signals have a voltage level of 1 V_{ss}.

The encoder connection on the motor side is designed as a socket. For this version, the manufacturer provides a complete encoder cable, e.g. ERN 387 from the company Heidenhain, Item No. 0278599 with a length of 10 meters. You can also purchase an adapter cable, Item No. 0278581. Contact to the inverter manufacturer about other encoder cables.

The encoder is connected at the inverter using a socket connector.

- Only use this encoder for field-oriented control with a speed accuracy < 1 %.
- Connect the encoder mechanically rigid to the motor.

8.4 Controlling the external connections of the inverter

- Do not place any gearbox between encoder and motor.

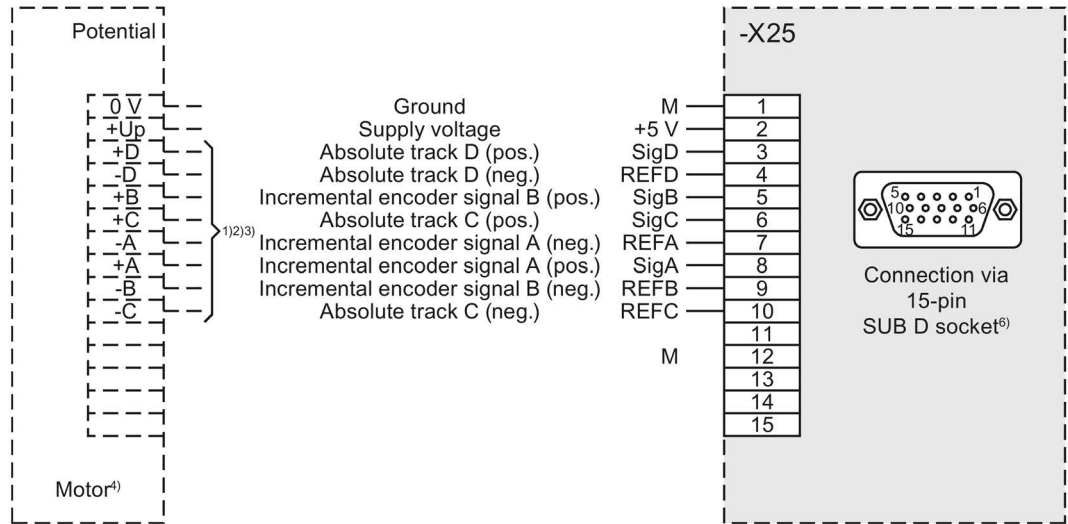

Figure 8-18 Sincos encoder at -X25

- Use twisted pair cables for the same encoder tracks, e.g. A + / A -.
- Connect the cable shields at both ends - at the encoder and inverter connectors.

Connecting a TTL encoder to -X25

All encoder signals have a voltage level compliant with RS 422.

A socket connector, high density is used to connect to the inverter.

- Only use this encoder for field-oriented control with a speed accuracy < 1 %.
- Connect the encoder mechanically rigid to the motor.
- Do not place any gearbox between encoder and motor.

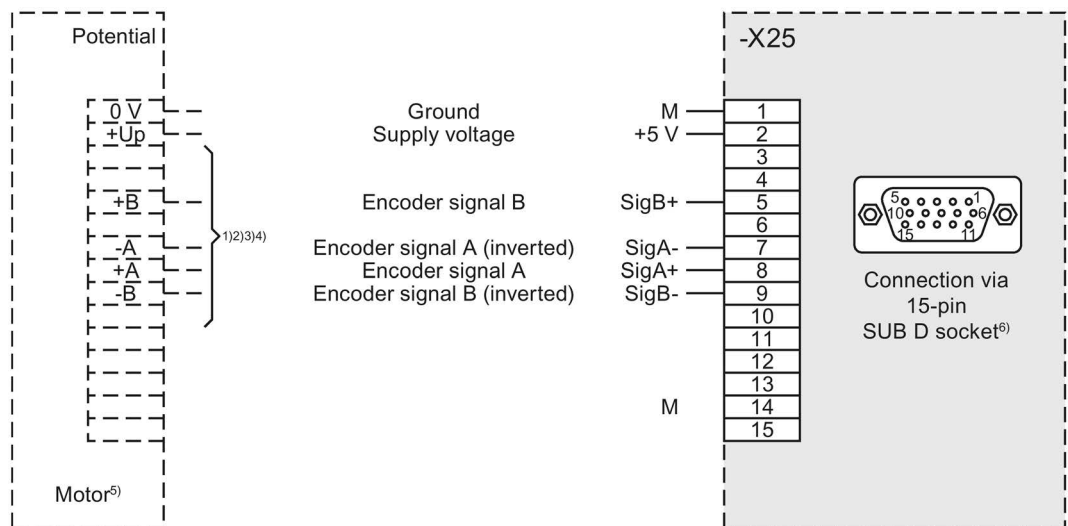

Figure 8-19 TTL encoder at -X25

- Use twisted pair cables for the same encoder tracks, e.g. A + / A -, B + / B -.
- Connect the cable shields at both ends - at the encoder and inverter connectors.

Connecting an HTL encoder at -X101

- Only use this encoder for field-oriented control with a speed accuracy < 1 %.
- Connect the encoder mechanically rigid to the motor.
- Do not place any gearbox between encoder and motor.

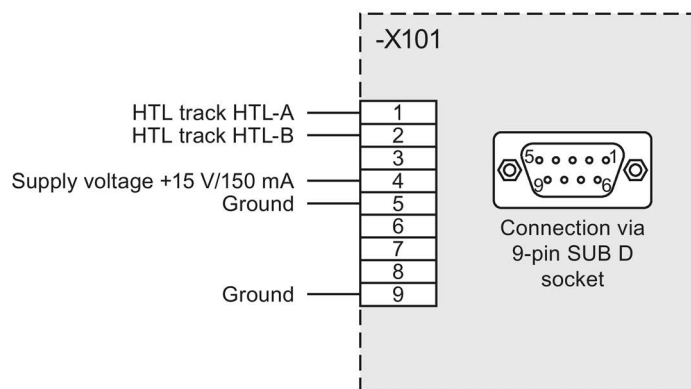

Figure 8-20 HTL encoder at -X101

- When fabricating your own encoder cables, only connect the cable shield at the inverter.

8.4.7 Connect the PC via USB at -X50B

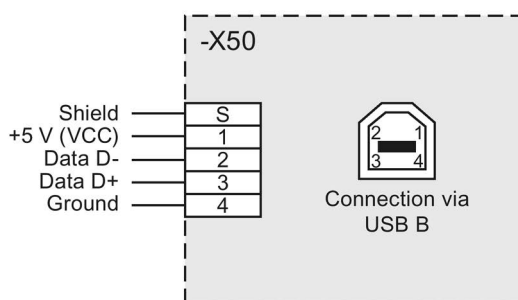



Figure 8-21 PC at -X50B via USB

8.4 Controlling the external connections of the inverter

Connect USB socket -X50B to a USB port of your notebook. Use a standard cable that is not longer than 3 m.

 CAUTION
Personal injury caused by a defective device or inverter
When connecting-up, carefully observe the information provided in Chapters "USB interface (Page 149)" and "Protective separation according to EN 61800-5-1 (Page 145)".

The version of the installed IMS software must be "Z24" or higher. The USB connection feature is not available in earlier versions.

In menu "Options/drivers", select the USB driver.

8.4.8 Connecting a PC to -X51 via RS 232

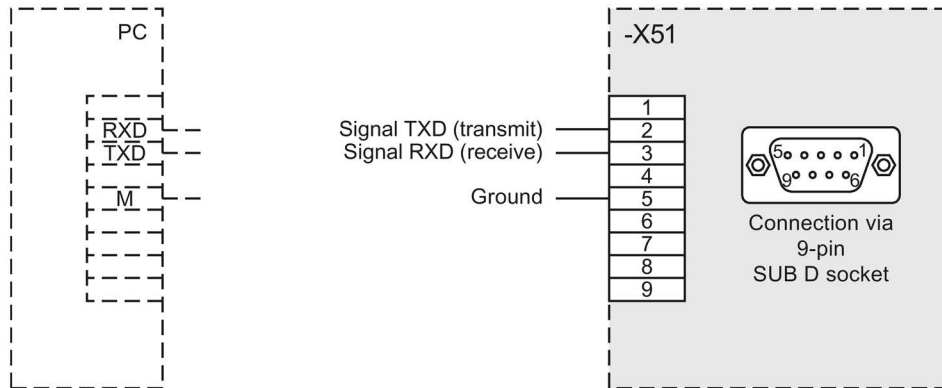

Figure 8-22 PC at -X51 via RS 232

NOTICE
Damage to the inverter electronics or the PC
The pins of socket -X51 are assigned signals other than those shown here. Do not use a standard cable that is completely assigned as otherwise the inverter electronics or the PC could be damaged. Only use cables where only the required pins are assigned.

Further information about connecting PC and inverter, etc. can be found in the help in the software "IMS".

- Connect the cable shield at both sides on the Sub-D housing.

If you want to use the "IMS" software to change the inverter parameters, the parameter "P-INTERFACE/Para-Source" must be set to "Global" or "RS485". "Global" is the default setting.

- Using the "IMS" software, configure which COM port the cable on the PC will be connected to.
 - The default setting is COM1.
- Select the configuration under "Options/Drivers/RS232-485-Driver" .

8.4.9 Connection for optional external display with RS 485

You have the option of connecting an external display at -X51 or at -X26. The connection assignment for an external display with RS 485 is shown in the following diagrams.

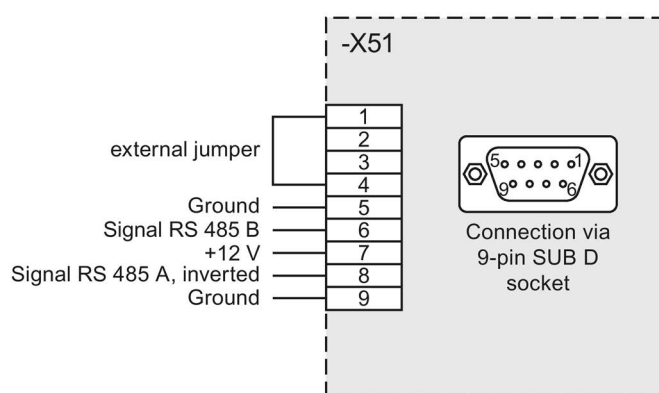

Figure 8-23 External display connected at -X51

In order to be able to issue commands via an external display connected at -X51 to the inverter, set the corresponding command source in the parameter assignment to "RS 485".

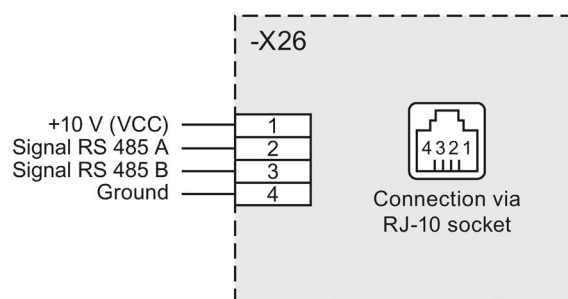

Figure 8-24 External display connected at -X26

The -X26 interface is only suitable for an external display, for instance installed in the cabinet door.

In order to be able to issue commands via an external display connected at -X26 to the inverter, set the corresponding command source in the parameter assignment to "internal".

8.5 Special functions

8.5.1 Protective functions

Main contactor

If you install a main contactor in your application, this can be controlled using the inverter software.

In this case, the coil is controlled via a digital output. Feedback from the normally open contact of the main contactor is realized via digital input -X2:8.

You can provide the main contactor on the mains power side, NS in short, or on the motor side, MS in short. Parameter "P-INV. BEHAVIOUR/MCfunc" specifies when the main contactor is switched and where the main contactor must be installed.

Example: Shutdown only in the case of an error, installation on the mains power or motor side.

The following settings are possible:

Table 8- 7 Contactor functions for different parameters

"MCfunc"	The protection is ON for ...			
	"Fault"	"OFF 1"	"Controller release" no internal control- ler voltage	"Speed On" no internal speed off
"LinC no fault"	No	-	-	-
"LinC rdy.f.op"	No	No	-	-
"LinC rel.f.op"	No	No	Yes	-
"LineC operat."	No	No	Yes	Yes
"MotC no fault"	No	-	-	-
"MotC rdy.f.op"	No	No	-	-
"MotC rel.f.op"	No	No	Yes	-
"MotC operat."	No	No	Yes	Yes

Line contactor

The inverter controls its own line contactor. Note that the supply voltage for the control electronics is tapped before the main contactor. You can find additional information in Chapter "Connecting the external 230 V AC for compact devices (Page 111)". Perform the wiring in accordance with the following plan:

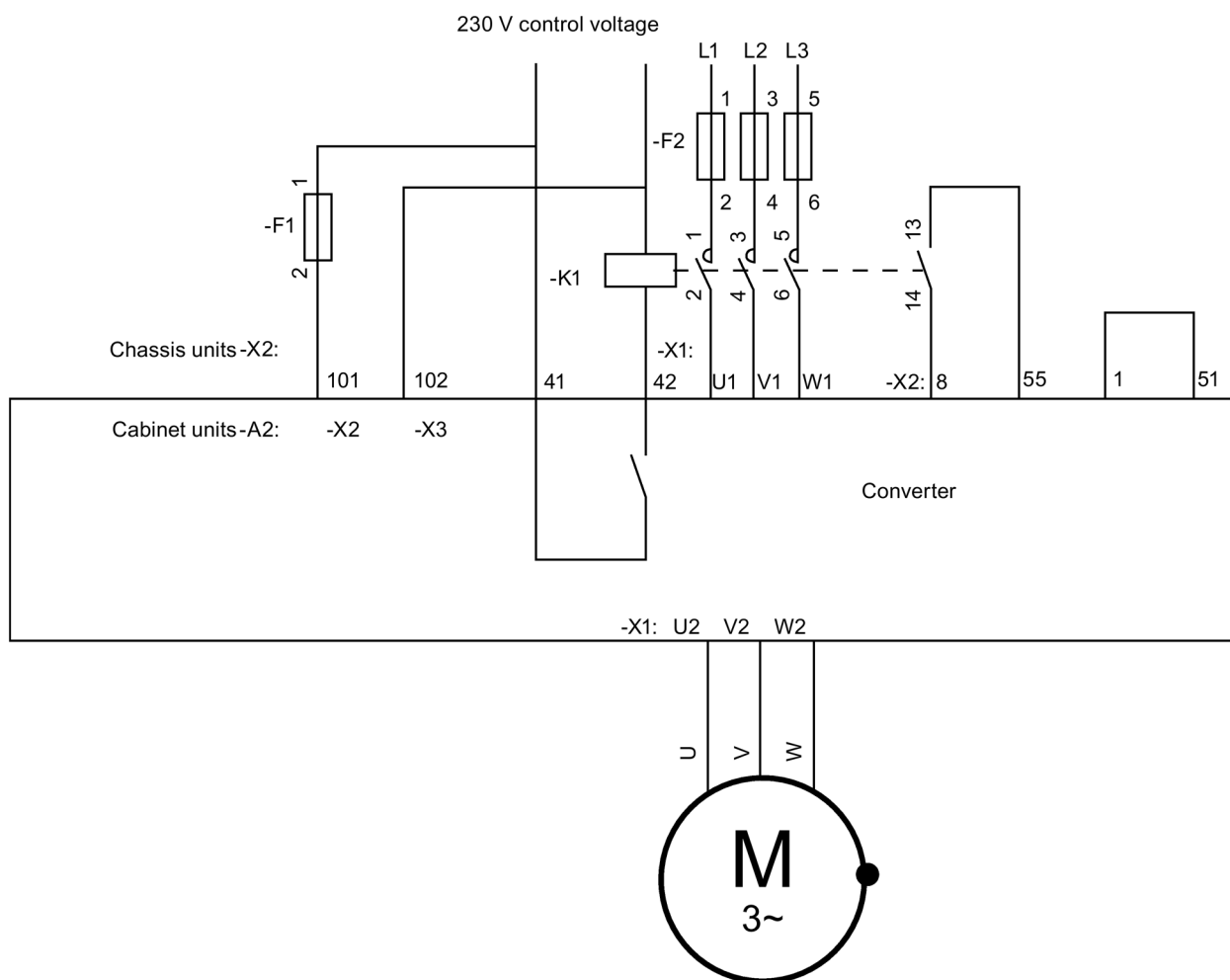

Figure 8-25 Line contactor function

Table 8- 8 Line contactor functions

Terminal / component	Function
-F1	External control voltage fuse protection
-F2	Inverter power unit fuse protection
-K1	Input side main contactor Design recommendation: AC1 current of the contactor is at least the inverter input current
101, 102	External control voltage for the 230 V inverter
41, 42	Digital output for the main contactor control
U1, V1, W1	Mains power connection switched via main contactor
8	Main contactor feedback input
55	24 V DC supply voltage
1, 51	Jumper for ground connection
U2, V2, W2	Motor connection

NOTICE

Coil currents in excess of 1 A at contact 41/42

If you load the contact 41/42 with coil currents of more than 1 A, the contact can be destroyed.

In the case of coil currents of more than 1 A, connect an auxiliary relay between terminal 41/42 and the main contactor coil.

Make the following settings in order to activate the main contactor function:

- The preselection for the inputs/outputs for the control must be as follows:
 - "P-DRIVE DATA/A = Namur" or
 - "P-DIGITAL OUTPUTS/Relay 2 = main contactor" and "P-OPERATION/Cont. feedback = X2:8"
- For "P-INV. BEHAVIOUR/MCfunc" the setting "LinC..." must be entered.

Motor contactor

The inverter controls the contactor at the inverter output.

- Perform the activation as for the line contactor.
- Different than for the line contactor, for "P-INV. BEHAVIOUR/MCfunc" as value select the parameters that have "MS" as prefix for motor contactor.
- Dimension the output side contactor according to the AC3 current.
- Perform the wiring in accordance with the following plan:

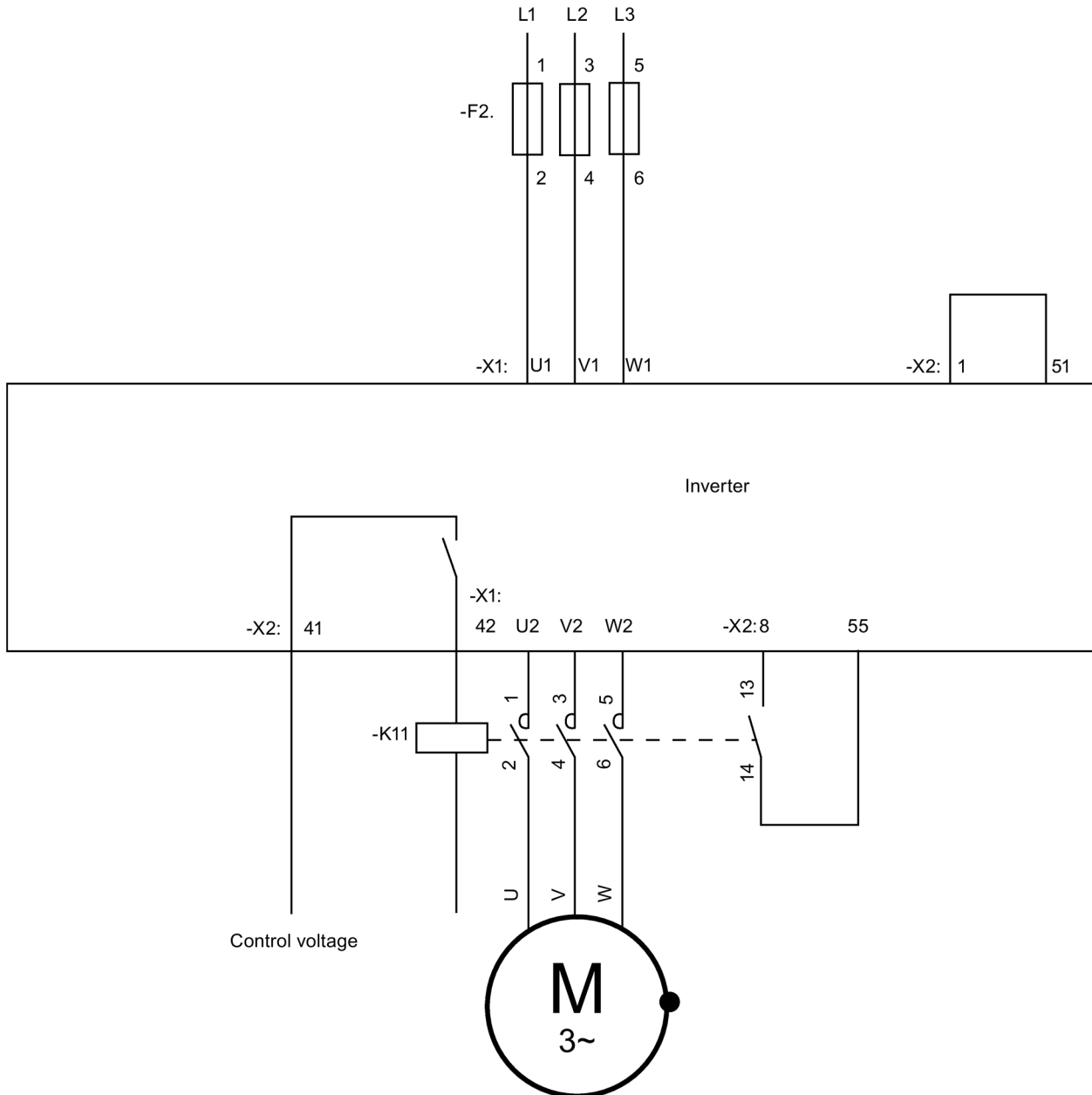

Figure 8-26 Motor contactor function

Table 8-9 Motor contactor functions

Terminal / component	Function
-K11	Output side main contactor Design recommendation: AC3 current of the contactor is at least the inverter output current
41, 42	Digital output for the main contactor control
U1,V1,W1	Mains connection
8	Main contactor feedback input
55	24 V DC supply voltage
1 und 51	Jumper for ground connection
U2, V2, W2	Motor connection

8.5.2 Multiple function of the analog and digital inputs

Analog inputs 1 and 2

The analog inputs have several functions:

- Under "P-ANALOG INPUTS/Analog input 1/AI-function", you can set the value from "Analog" to "PTC", "KTY84" or "PT100".
- Under "P-ANALOG INPUTS/Analog input 2/AI-function" you can set analog input 2 from "Analog" to "PTC", "KTY84" or "PT100".
- Also adjust the corresponding DIL switches of the -S2 switch row on board CB08.
- You can find more detailed information in Chapter "DIL switches "S1" and "S2" (Page 149)".

The following functions are now available:

- "Analog":
The analog input operates as a voltage input at control cable terminals -X2:52-51 / 54-51 or as a current input at control cable terminals -X2:50-51 / 53-51. The value is available as "AI 1" or "AI 2" for further processing.
- "PTC":
The analog input operates as a PTC thermistor input at control cable terminals -X2:50-51 / 53-51. The PTC thermistor state is available for further processing as selection bit "PTC AI 1" or "PTC AI 2".
- "KTY84":
The analog input operates as a direct input for a KTY84-130 temperature sensor at control cable terminals -X2:50-51 / 53-51. The measured temperature is available as an analog value under "T-AI1" or "T-AI 2" for further processing.
- "PT100":
The analog input operates as a direct input for a PT100 temperature sensor at control cable terminals -X2:50-51 / 53-51. The measured temperature is available as an analog value under "T-AI1" or "T-AI 2" for further processing.

Any analog input can only be used for one function. It is not possible to use several functions simultaneously for one input.

Digital inputs -X2:27 and -X2:28 as PTC thermistor inputs

The digital inputs are interpreted as a normal digital input for control with a 24 V signal. If these control cable terminals are wired to 10 V potential using a PTC thermistor sensor, these function automatically as PTC thermistor monitoring inputs. The selection bits "PTC X2:27" and "PTC X2:28" indicate the PTC thermistor status. However, do this it is mandatory that you have set parameter "P-PULSE INPUT/Mode = inactive".

NOTICE

Unsuitable evaluation unit

The inverter can be damaged if the PTC thermistor for explosion proof motors or for safe isolation is not evaluated using an ATEX-certified, safely isolated evaluation unit or the peripherals board.

Use an ATEX-certified, safely isolated evaluation unit or the peripherals board for safe operation.

Digital inputs -X2:27, -X2:28 and -X2:29 as frequency or tachometer inputs

These digital inputs can be used as a frequency or tachometer input, for example, in the following way.

- The field-oriented control at input -X25 / -X101 is not possible, e.g. if the n-sensor is installed on the machine and there is a gearbox between machine and motor.
- Only one simple proximity switch with e.g. four impulses per revolution is available. The resolution for the field-oriented regulation is too small in this case. It is suitable for displays or more precise speed regulation.
- You connect a frequency-dependent setpoint generator of the type used for mining applications, for example.

Example applications for the digital inputs as frequency inputs:

- Proximity switch with NAMUR output or with PNP-3 wire output
- Two-channel digital tachometer with HTL output

In order that you can use these inputs as frequency or tachometer input, you must select the required evaluation function using parameter "P-PULSE INPUT/Mode". Independent of the selected evaluation function, as a result, inputs -X2:27 to :29 are assigned, and are no longer available as digital inputs. The digital input bits in the bit pool X2:27, X2:28 and X2:29 are connected to a fixed value of "0". Likewise, the bits in the bit pool for the PTC evaluation "PTC X2:27" and "PTC X2:28" are connected to 0. These can no longer be used.

Possible warnings and faults that are obtained that can be parameterized, for example "MotorWindingTemp." must be resolved by making the appropriate parameter change, e.g. setting to "inactive".

Proximity switch with NAMUR output or with PNP-3 wire output

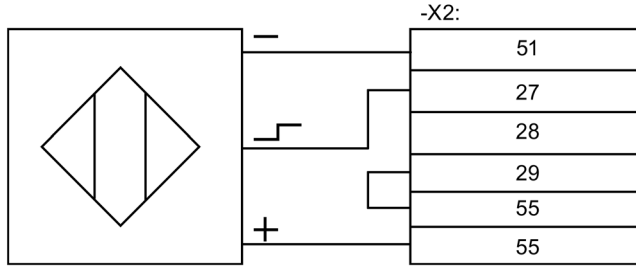

Figure 8-27 PNP speed sensor

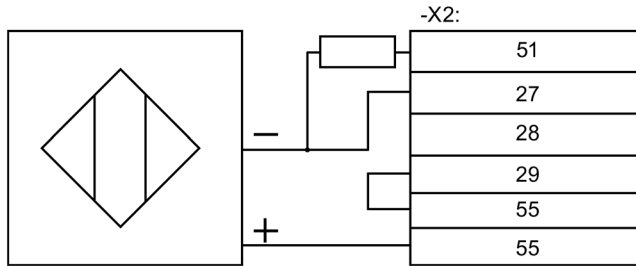

Figure 8-28 NAMUR speed sensor

Assumption: sensor produces four impulses per revolution for four-pole motor, $n_{max} = 1500$ rpm.

Note the following:

This speed is available for further processing as "Tacho act" from 0 rpm to 1500 rpm and as "Pulse act" from 0 % to 100 %.

- Connection according to connection diagram.
You must connect the tachometer signal at terminal -X2:27. You must keep terminal -X2:28 free, and control terminal -X2:29 with 24 V (e.g. jumper from -X2:29 to -X2:55) for an evaluation as 1-track tachometer or as frequency evaluation. Bit pool bits "X2:27" to "X2:29", "PTC X2:27" and "PTC X2:28" are permanently set to "0".
- Parameterize the following:
 - At $f \neq 20$ kHz: $1500 \text{ rpm} / 60 \text{ s} \times 4 \text{ pulses} = 100 \text{ Hz}$.

Select the following values for the respective parameters:

Table 8- 10 parameter setting for speed sensor

Parameter	Value
"P-PULSE INPUT/Mode"	"Tacho 1-track"
"P-PULSE INPUT/Max-plse."	"1,500 rpm"
"P-PULSE INPUT/Pulses/360"	"4"

Set the following parameters if a frequency value is needed for the further processing:

Table 8- 11 parameter setting for speed sensor with frequency value

Parameter	Value
"P-PULSE INPUT/Mode"	"f < 20 kHz"
"P-PULSE INPUT/Max-plse."	"100 Hz"
"P-PULSE INPUT/Pulses/360"	"4"

The frequency is available for further processing as "Freq.act." from 0 Hz to 100 Hz and as "Pulse act" from 0 % to 100 %.

NPN sensors cannot be used.

Two-channel digital tachometer with HTL output

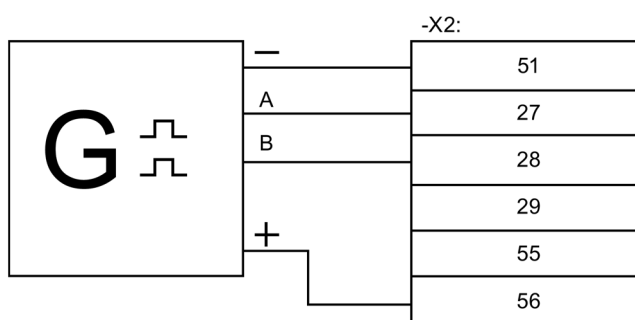

Figure 8-29 Digital tachometer, two-channel, HTL level

Assumption: digital tachometer produces 1,024 impulses per revolution for four-pole motor, $n_{max} = 1500$ rpm

Note the following:

- Connection according to connection diagram. You must keep input -X2:29 free. Bit pool bits "X2:27" to "X2:29", "PTC X2:27" and "PTC X2:28" are permanently set to 0.
- Check the frequency in the range from 20 kHz to 205 kHz:
 $1500 \text{ rpm} / 60 \text{ s} \times 1024 \text{ impulses} = 25.6 \text{ kHz}$

Select the following values for the respective parameters:

Table 8- 12 parameter setting for digital tachometer

Parameter	Value
"P-PULSE INPUT/Mode"	"Tacho 2-track"
"P-PULSE INPUT/Max-plse."	"1,500 rpm"
"P-PULSE INPUT/Pulses/360"	"1,024"

The speed is available for further processing as "Tacho act" from 0 rpm to 1500 rpm and as "Pulse act" from 0 % to 100 %.

8.6 Setpoint channel and closed-loop control

Set the following values for the respective parameters if a frequency value is needed for the further processing:

Table 8- 13 parameter setting for digital tachometer with frequency value

Parameter	Value
"P-PULSE INPUT/Mode"	"f > 20 kHz"
"P-PULSE INPUT/Max-plse."	"25,600 Hz"
"P-PULSE INPUT/Pulses/360"	"1024"

The frequency is available for further processing as "Freq.act." from 0 Hz to 25.6 kHz and as "Pulse act" from 0 % to 100 %.

8.6 Setpoint channel and closed-loop control

8.6.1 Specifying source for speed setpoint

Specify under "P-SPEED DEFAULT/n Set source" the setpoint source to which the inverter must respond, e.g. including:

- "Internal" using <up arrow> or <down arrow> of the display
- "AI 1" via analog input 1 of the control terminal block -X2
- "BUS 1" as control word via the optional fieldbus connection

8.7 Parameterization

8.7.1 Principle of operation of the configuration

NOTICE
<p>Incorrect parameter settings</p> <p>The inverter and other connected components can be damaged or destroyed if the parameter settings are incorrect.</p> <p>Only qualified personnel may change parameters; the instructions in the Operating Manual and the technical data of the inverter and connected components must be carefully observed.</p>

Parameterization is based on the principle - Input → Processing → Output. Many functions in plain text are available in the bit pool for the input. You always have the selection from the

bit pool when you are in the menu of a processing function, for example when changing the function "P-ContrlRelease/Local" you have the selection "always" "IX2:8\IX2:9..."

Processing functions for the output are available, for example "P-digital outputs/Relays 1-4", "LED 1-2" or "P-analog outputs".

For processing, several functions are available, e.g. "P-MESSAGE GEN MESS" or "P-PARAMETER SWITCH".

The following graphic clarifies this processing method:

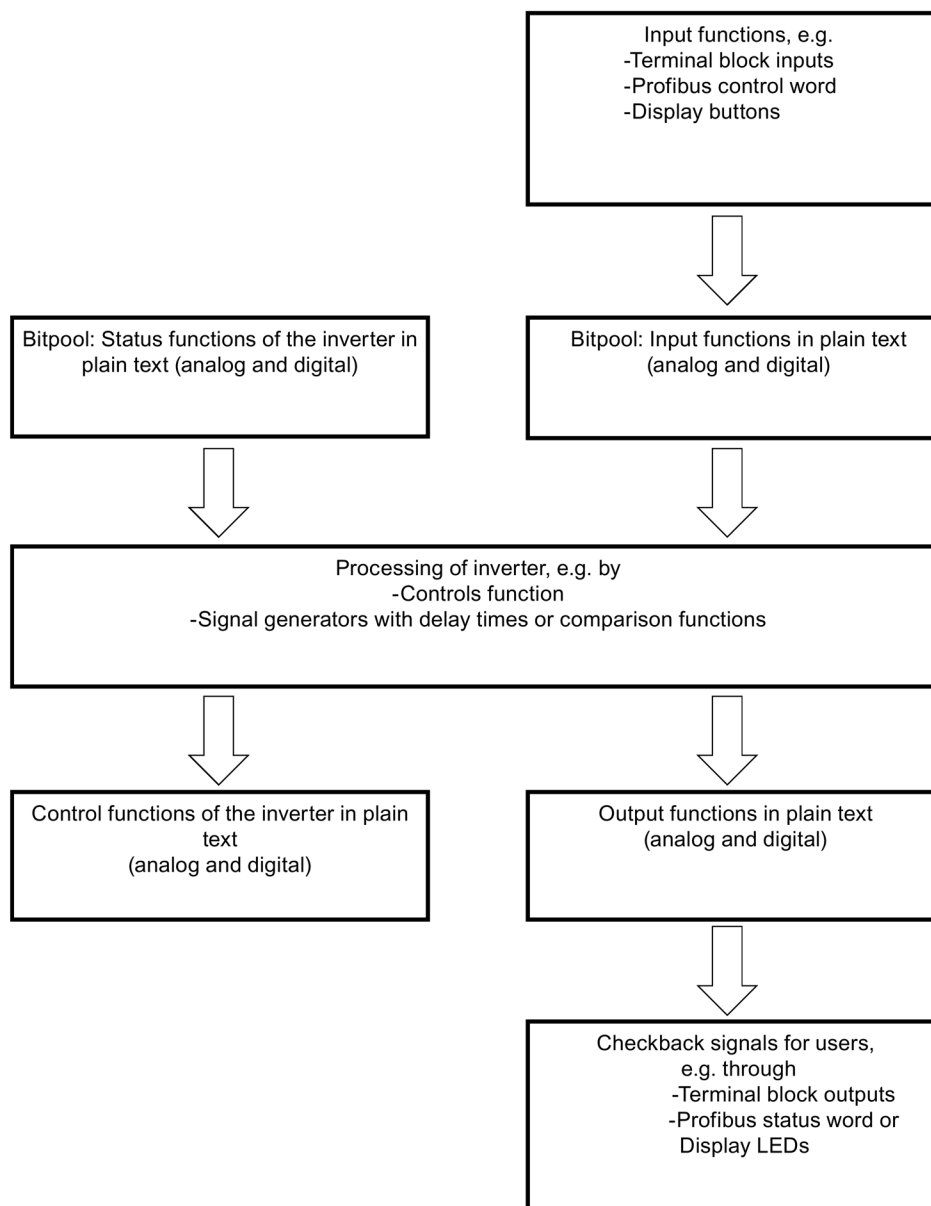



Figure 8-30 Configuration principle of operation

8.7.2 Protecting parameters against modification

 WARNING
Undesirable machine response
The machine can respond undesirably as a result of incorrect or modified parameterization of the inverter. This can result in death, serious injury or material damage.
<ul style="list-style-type: none">• Protect the parameterization (parameter assignments) against unauthorized access.• Read and carefully follow the instructions in this document and all of the relevant documents.• If necessary, contact our Service Center.

You can configure all parameters of the inverter in the delivery state using the internal control panel or via an RS 232 connection to a PC running the "IMS" software.

If you would like that the inverter should only be configured from one location, you can set this under "P-INTERFACE/Para-source".

If you would like to no longer allow any parameter changes, you must set the DIL switch S1.1 to "Off". The precise position of this DIL switch is described in Chapter "Sub-D and USB connections and DIL switches (Page 148)".

8.7.3 Configuration using the inverter display

1. You reach the configuration menu by pressing the button <P>. The display "P-DRIVE DATA" is shown in the first line.
2. Individual menu items can be selected using <up arrow> and <down arrow>. For example, you reach "P-INTERFACE" using the <down arrow>.
3. When "P-DRIVE DATA" is displayed, press <Return> in order to display the submenu of "P-DRIVE DATA". The first parameter of "P-DRIVE DATA" "fmin" is shown in the second line.
4. If you again press <Return>, then in the 2nd line a black bar is displayed between the parameter name and value. This means that the parameter is unlocked, and you can enter a new value for the parameter using <Arrow up> or <Arrow down>.
5. If you press <Return> again, then the black bar disappears again. This indicates that the parameter is again locked. Some parameters are accepted with the lock; others are already accepted when the value is changed.
6. Press <Arrow up> or <Arrow down> to reach other parameters or submenus. Press <Return> to reach submenus. Press <P> to go one level higher in the menu structure.

You can then use the same principle of operation in any other menu.

8.7.4 More documentation about parameterization

You can find further documentation relating to parameterization on the Internet at www.siemens.com (<http://www.siemens.com>)

8.8 Examples / Applications

8.8.1 "Standard" application

8.8.1.1 Standard control cable terminals

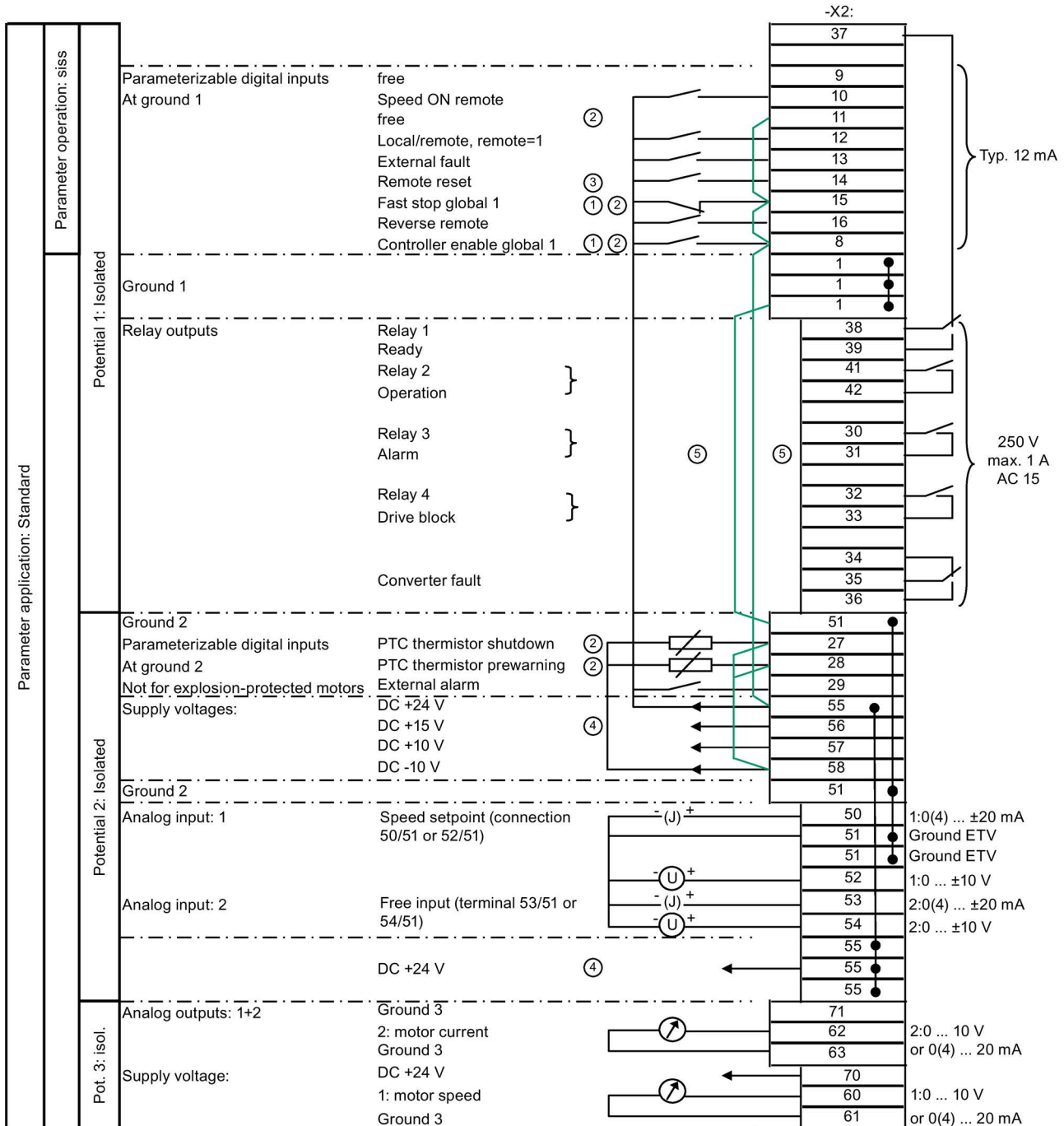

- ① Global = functional for "Local" and "Remote"
- ② If you use these inputs, remove the jumper.
- ③ As long as "P-INTERFACE/Reset-Source" is set to "Global", all reset sources are always effective.
- ④ Max. current load of the control voltages:
 - +24 V DC, potential 2: 300 mA
 - +15 V DC, potential 2: 150 mA ±10 mA
 This voltage can supply a speed encoder connected at terminal -X101.
- ⑤ Remove both these jumpers if you are using peripheral boards 3 / 4. The supply is realized via -X2:1/3.

Figure 8-31 Control cable terminals for the "Standard" application

8.8.1.2 Control cable terminals "peripheral board 1"

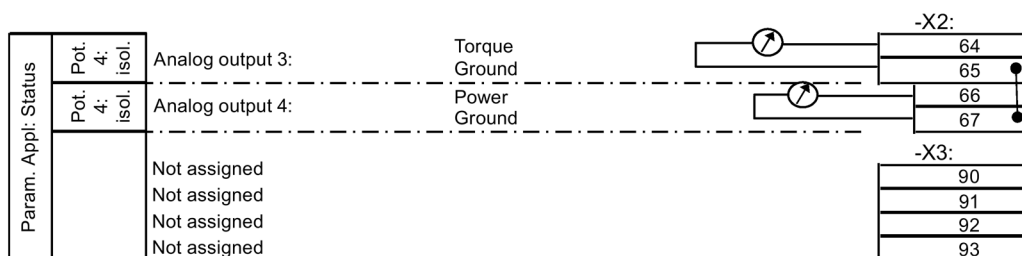
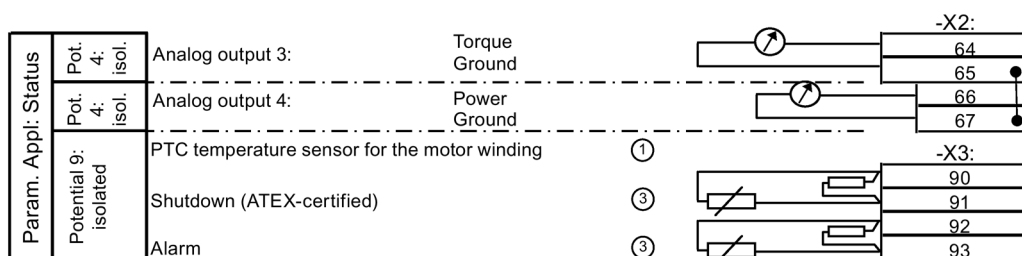

Figure 8-32 Control cable terminals for the "peripheral board 1" option

8.8.1.3 Control cable terminals "peripheral board 2"



- ① PTC inputs, suitable for motors in hazardous zones or non-hazardous zones
- ③ Remove the 100 Ω resistor if these control cable terminals are in use.

Figure 8-33 Control cable terminals for the "peripheral board 2" option

8.8.1.4 Control cable terminals "peripheral board 3"

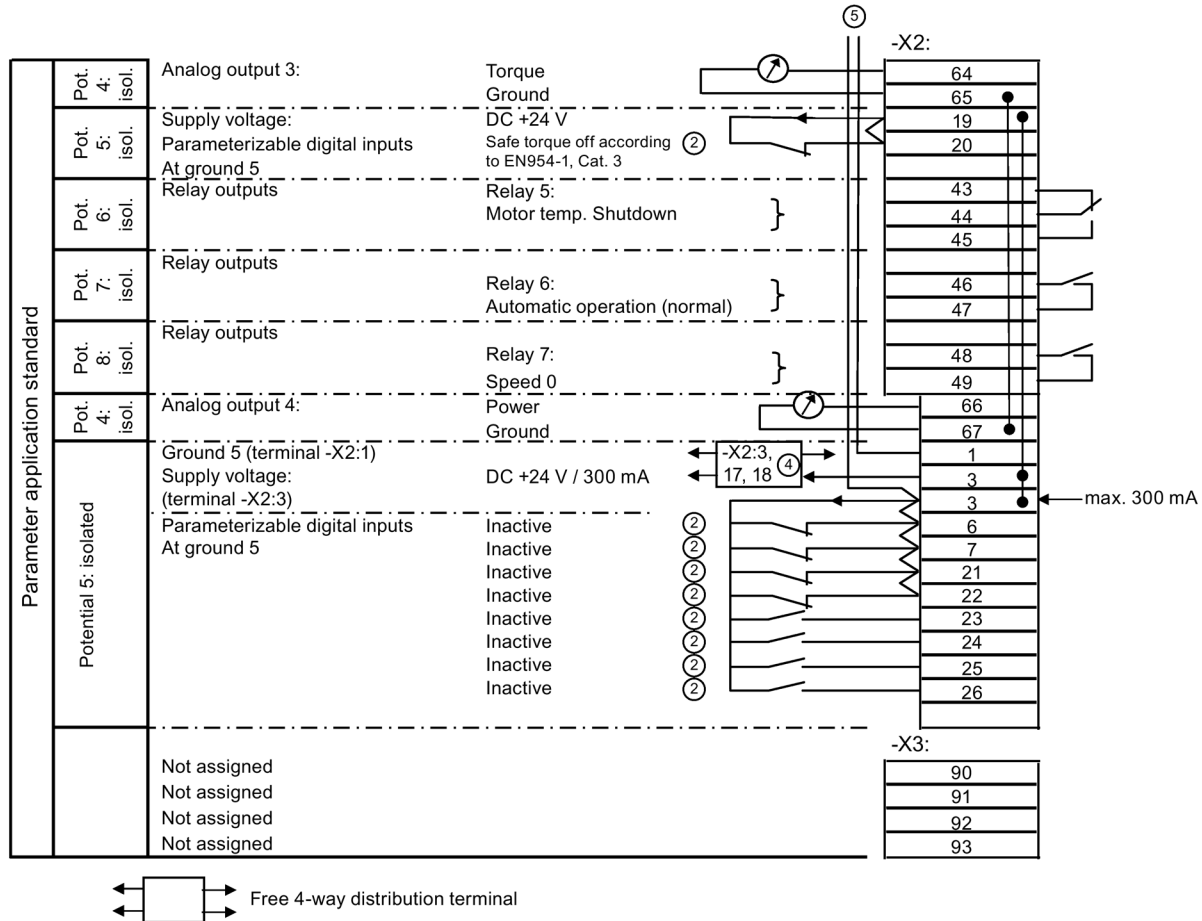

- ② Remove the jumper if these control cable terminals are in use.
- ③ -X2:3: Four-way distribution terminal for 24 V, -X2:17, 18: Not assigned
- ④ In the case of an equipped peripheral board 3 / 4, the supply of the digital inputs -X2:8 ... 16 is changed over. The digital inputs are supplied from -X2:1/3 instead of -X2:51/55.

Figure 8-34 Control cable terminals for the "peripheral board 3" option

8.8.1.5 Control cable terminals "peripheral board 4"

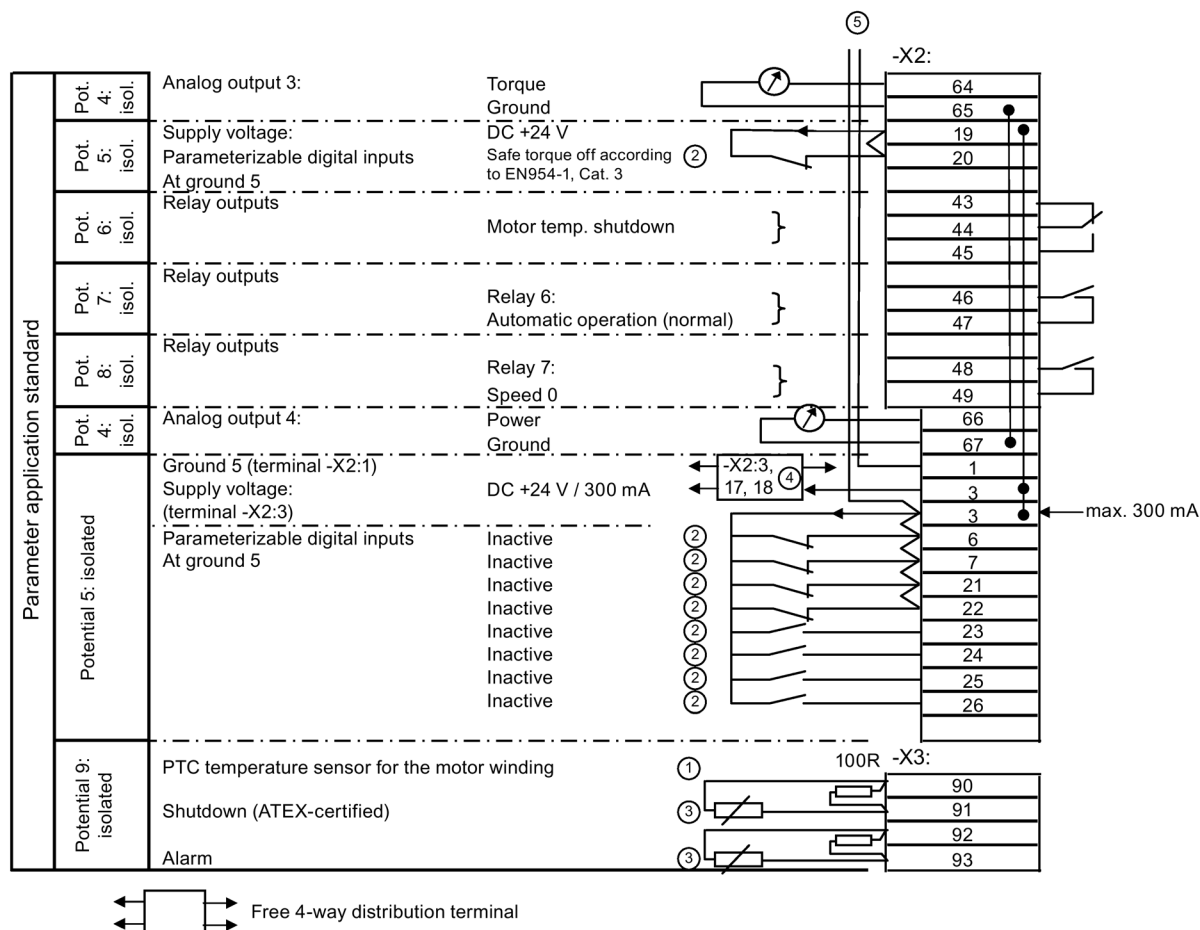

Figure 8-35 Control cable terminals for the "peripheral board 4" option

8.8.1.6 Operation setting for the "Standard" application

The mode setting for the "Standard" application is "siss". You can find more detailed information in Chapter "Standard mode settings (Page 135)".

8.8.1.7 Assignment of the digital inputs

Terminal -X2:13	External fault input. In the case of actuation with 24 V, this results in an error shut-down with storage.
Terminal -X2:29	External warning. In the case of actuation with 24 V, this results in a warning without storage.
Terminal -X2:27	Connect a motor PTC thermistor for the motor monitoring here. If the sensor is triggered, a "Motor overtemperature" shutdown is performed, which is stored. You can find more detailed information in Chapter "Multiple function of the analog and digital inputs (Page 160)". In the case of the "peripheral board 2 / 4" option, connect the PTC thermistor connector to the peripheral board.
Terminal -X2:28	Connect another motor PTC thermistor for the motor monitoring here. If the sensor responds, then a warning is issued with "!! Prewarning !! Motor overtemperature" is output, which is not stored. You can find more detailed information in Chapter "Multiple function of the analog and digital inputs (Page 160)". In the case of the "peripheral board 2 / 4" option, connect the PTC thermistor connector to the peripheral board.
In the case of the "peripheral board 3 / 4" option	The digital inputs are set to inactive and can thus be freely used for other configurations.

8.8.1.8 Assignment of the digital outputs

Relay 1, terminal -X2:37, 38, 39	The "Ready" message as changeover contact in the open-circuit principle is available here. Ready for operation means that the inverter has no faults and the DC link is precharged.
Relay 2, terminal -X2:41, 42	The message "Working" is output here.
Relay 3, terminal -X2:30, 31	All warnings which are generated in board CB08 are signaled here in the open-circuit principle. Example: The message "!! Prewarning !! Inverter overtemp."
Relay 4, terminal -X2:32, 33	-
Relay outputs, terminal -X2:34, 35, 36	Inverter fault All faults which cause the inverter to shut down are signaled here with a changeover contact in the closed-circuit principle.
In the case of the "peripheral board 3 / 4" option, terminals -X2:43 ... 49	Messages "PTC X3:90", "X2:9" and "Speed zero" are active.

8.8.1.9 Assignment of the analog inputs

- Analog input one, terminal -X2:50, 51, 52:
 - You apply your speed setpoint to these terminals which is effective in the "Remote" mode.
 - You can use the terminal 50 as current input or the terminal 52 as voltage input. The terminal 51 is the ground connection.
 - The input range from 0 mA to 20 mA or from 0 V to 10 V is proportional to the output frequency from 0 Hz to 50 Hz.
- Analog input two, terminal -X2:53 and -X2:54:
 - Equivalent, additional analog input.

8.8.1.10 Assignment of the analog outputs

- Isolated terminal -X2:62, 63:
An output signal of 4 mA to 20 mA is present here. This corresponds to a motor current from zero up to a unit-dependent value.
- Isolated terminal -X2:60, 61:
This output provides a speed signal. A value from 4 mA to 20 mA is set as default value. This corresponds to a motor speed from 0 to 1500 rpm.
- Terminal -X2:64, 67:
For the "peripheral board 1 ... 4" option, the torque and the power are available at these terminals. A value from 4 mA to 20 mA is set as default value. The corresponding value as real variable depends on the power and is stored in the software "IMS".

8.8.1.11 Input "Safe torque off" / PTC thermistor inputs on peripheral board

- Terminal -X2:19/20:
These terminals are dedicated for triggering the "Safe torque off" function. This input is jumpered in the default setting. If you wish to use the "Safe torque off" function, then you must remove this jumper and connect an NC contact of the switching element that triggers the function.
- Terminal -X2:24
This terminal can be configured as a second trigger circuit for the "Safe torque off" function. The DIP-FIX switch (bail switch) -S3 on the peripheral board determines whether the "Safe torque off" function is controlled through one or two circuits. -S3 closed means through two circuits. To use this input as second circuit for the "Safe torque off" function, you must connect terminal -X2:24 with -X2:3 using an NC contact of the appropriate switching element.
- Terminal -X3:90/91:
This input is used for motor temperature monitoring certified according to ATEX. If you wish to use this monitoring function, then you must remove the existing resistor and connect the appropriate motor PTC thermistor.

NOTICE**Peripheral board 2 or 4 is required for monitoring**

The monitoring function is only available if the required peripheral board 2 or peripheral board 4 is inserted in the SINAMICS G180
If the peripheral board 1 or peripheral board 3 is installed, then although the terminals are available, there is no evaluation. There is no monitoring.

- Terminal -X3:92/:93:

This input is used as prewarning for the motor temperature monitoring. If you wish to use this function, then you must remove the existing resistor, and connect the appropriate prewarning motor PTC thermistor.

NOTICE
Peripheral board 2 or 4 is required for monitoring
The monitoring function is only available if the required peripheral board 2 or peripheral board 4 is inserted in the SINAMICS G180 If the peripheral board 1 or peripheral board 3 is installed, then although the terminals are available, there is no evaluation. There is no monitoring.

Detailed information

More detailed information is provided in Chapter "Peripheral boards 1 to 4, -A95, option G02 to G05 (Page 37)".

8.8.2 "Namur" application

8.8.2.1 Control cable terminals for the "Namur" application

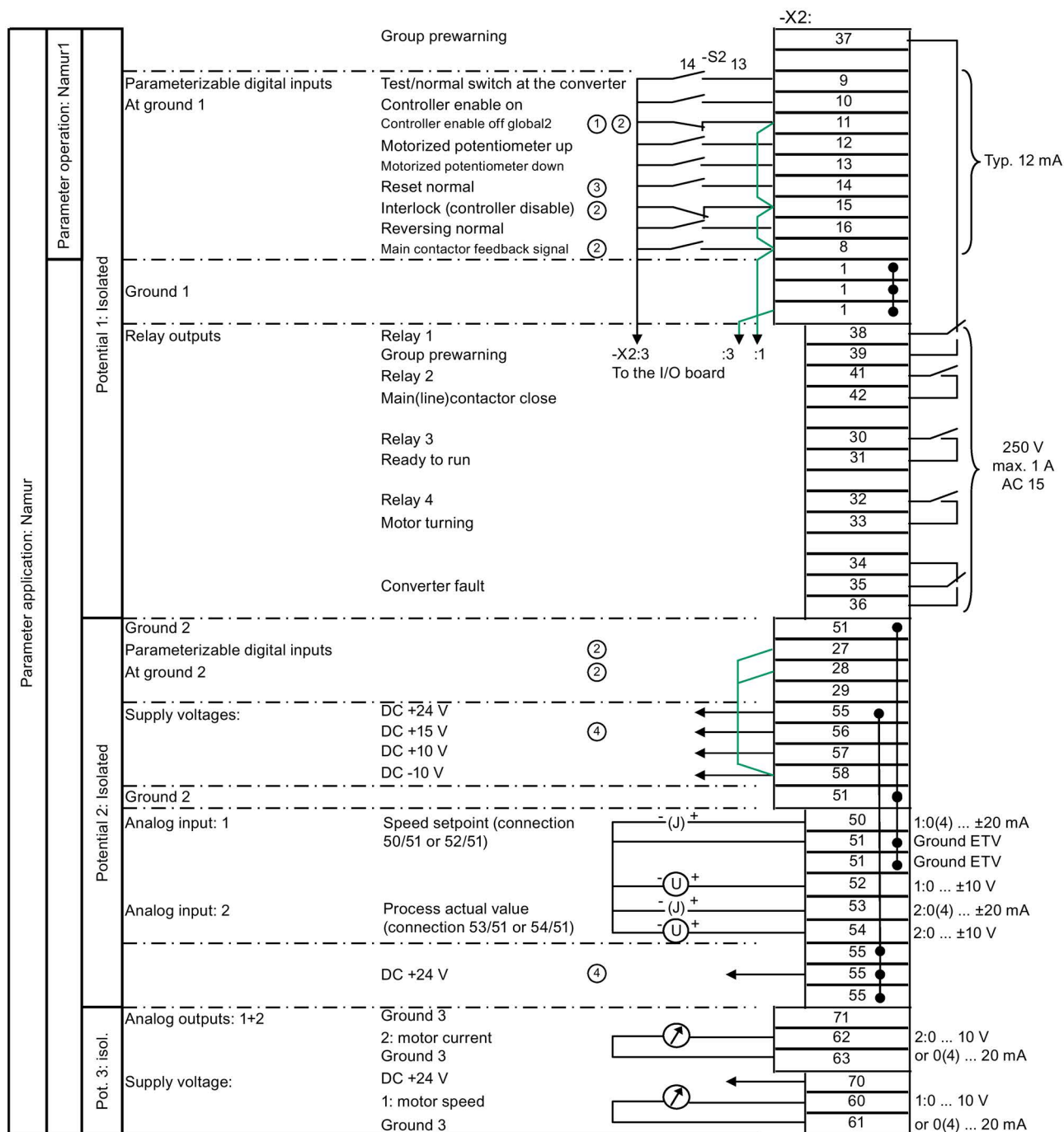

8.8 Examples / Applications

- ① "Global" = functional for "Test" and "Normal"
- ② If you use these inputs, remove the jumper.
- ③ As long as "P-INTERFACE/Reset-Source" is set to "Global", all reset sources are always effective.
- ④ Max. current load of the control voltages:
 - + 24 V DC, potential 2: 300 mA
 - + 15 V DC, potential 2: 150 mA ± 10 mAThis voltage can also supply a speed encoder connected at terminal -X101.

Figure 8-36 Control cable terminals for the "Namur" application

8.8.2.2 Control cable terminals "peripheral board 4"

NOTICE
Non-compliance with NAMUR guideline NE-37
The NAMUR guideline NE-37 is only completely implemented with the "peripheral board 4" option.

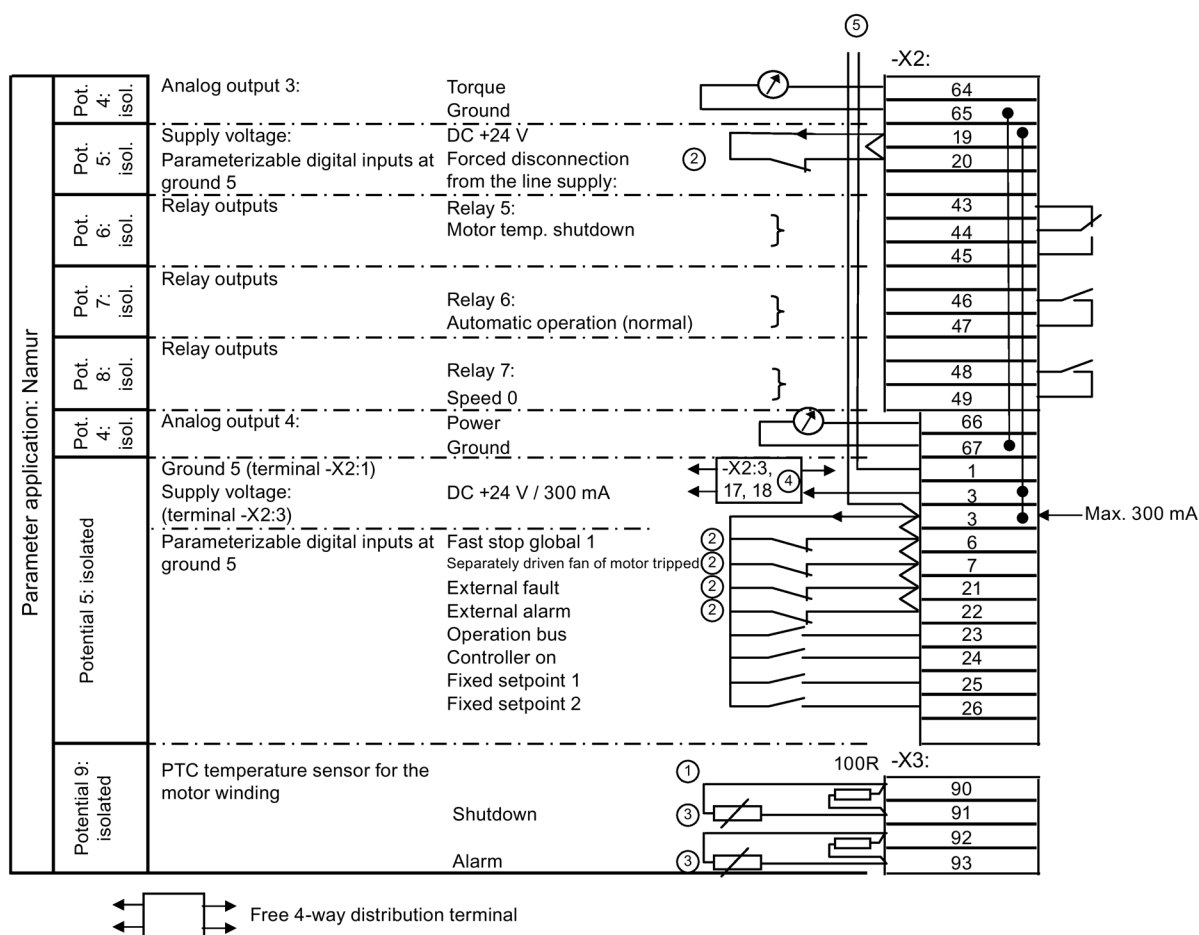

- ① PTC inputs, suitable for motors in the Ex-zone or Non-Ex-Zone
- ② If you use these inputs, remove the jumper.
- ③ If you use these inputs, remove the 100 Ω resistor.
- ④ -X2:3: Four-way distribution terminal for 24 V, -X2:17, 18: For Emergency Off input
- ⑤ In the case of equipped peripheral board 3 / 4, the supply of the digital inputs -X2:8 to 16 is changed over. The digital inputs are now supplied from -X2:1/3 instead of -X2:5/1/55.

Figure 8-37 Control cable terminals for "peripheral board 4" application

This application fulfills the requirements concerning the terminal assignment and the inverter functions which have been developed by the "Normengemeinschaft für Mess- und Regelungstechnik", in short NAMUR. These specifications can be found in the NAMUR NE37 guideline.

Perform the wiring of the terminal block in accordance with the terminal plan. Remove the factory-installed jumpers according to the "Standard" application if the respective application requires this.

8.8.2.3 Operation setting of the "Namur" application

The mode setting for the NAMUR application is "Namur 1". Refer to Chapter "NAMUR mode settings (Page 138)" for more detailed information.

8.8.2.4 Assignment of the relay outputs

- Terminal -X2:41, 42:
You can control the main contactor using these terminals. The main contactor function is not activated in the software for the NAMUR application. More detailed information is provided in Chapter "Protective functions (Page 156)".
- Terminal -X2:37, 39:
All warnings which are acquired in board CB08 are signaled here with a changeover contact in the open-circuit principle, e.g. message "!! Prewarning !! Inverter overtemp."
- Terminal -X2:30, 31:
The "Rdy.f.work" message as normally open contact is available here. Rdy.f.work means that the inverter has no faults and the DC link is pre-charged.
- Terminal -X2:32, 33:
The contact closes if the motor is turning.
- Terminal -X2:34 ... 36:
"Inverter fault" All faults which cause the inverter to shut down are signaled here with a changeover contact in the closed-circuit principle.
- Terminal -X2:43 ... 49:
In the case of the "peripheral board 4" option: then messages "PTC X3:90", "X2:9" and "Speed zero" are active here.

8.8.2.5 Assignment of the analog inputs

- Terminal: -X2:50 ... 52:
 - Apply the speed setpoint which is active in normal operation to these terminals.
 - You can use the terminal 50 as current input or the terminal 52 as voltage input. The terminal 51 is the ground connection.
 - The input range from 0 mA to 20 mA or from 0 V to 10 V is proportional to the output frequency from 0 Hz to 50 Hz.
- Terminal: -X2:53, 54:
 - The signal for the speed actual value feedback can be supplied to this input. The values 0 mA to 20 mA at terminal 53 and 0 V to 10 V or up to 180 V at terminal 54 are preset.
 - You can connect an analog motor tachometer to these terminals.
 - More detailed information is provided in Chapter "DIL switches "S1" and "S2" (Page 149)".
 - You can use the signal in the software for limit value comparisons or as display.

8.8.2.6 Assignment of the analog outputs

- Isolated terminal -X2:62, 63:
An output signal of 4 mA to 20 mA is present here. This corresponds to a motor current from zero up to a unit-dependent value.
- Isolated terminal -X2:60, 61:
This output provides a speed signal. A value from 4 mA to 20 mA is set as default value. This corresponds to a motor speed from 0 up to 1500 rpm.
- Option "Peripheral board 4":
The torque and power are available at terminals -X2:64 ... 67. A value from 4 mA to 20 mA is set as default value. The corresponding value as real variable depends on the power and is stored in the software "IMS".

8.8.2.7 Input "Mandatory mains power isolation" / PTC thermistor inputs on peripheral board

More detailed information is provided in Chapter "Peripheral boards 1 to 4, -A95, option G02 to G05 (Page 37)".

Maintenance

9.1 Maintenance and servicing

For your personal safety and in order to prevent material damage it is essential that you carefully follow the instructions provided in Chapter "Safety information (Page 13)", especially Chapter "Notes for operator protection (Page 16)", and all safety-related instructions in your product documentation. Pay particular attention to the safety notices on the product itself.

There is an appropriate maintenance schedule for each device type. We recommended that maintenance is carried out at least once per year. For further information, please contact the Service Center, see Service & Support (Page 189).

Retighten all screw connections at regular intervals.

Depending on utilization, the installed fans each have a service life of between 5 and 10 years.

The service life of the lithium battery on the board CB08 is 10 years.

The electrolyte capacitors are designed for a service life of 20 years.

- Service the device after 5 years in accordance with a specified maintenance schedule.
- Check and clean the equipment and air filter mats (if present) depending on the accumulation of dust.

9.2 Replacing compact device

Procedure

Proceed as follows if a compact device must be replaced completely:

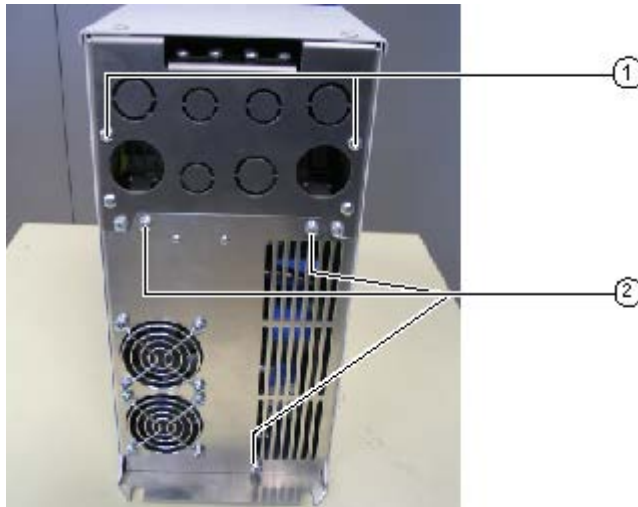

- ① Screws - device replacement
- ② Screws - fan replacement

Figure 9-1 Bottom view of compact device

1. Undo the device replacement screws on the outside.
2. Unscrew the cover at the front.
3. Slacken both the nuts of the cable entry plate in the upper connection space near the cover.
4. Disconnect the power cables.
5. Unplug the controller wiring connector.
6. Release the fastener on the mounting plate by only slackening the screws at the bottom.
7. Lift the inverter upward so that the cabling remains with the cable entry plate.
8. Install the new inverter in inverse sequence.

Observe the instructions for transporting inverters in Chapter "Transporting inverter (Page 71)".

9.3 Replacing fans for the compact device

Procedure

All internal converter fans are mounted in the lower section of the converter. Proceed as follows when removing:

1. Release the screws; wide converters have more screws than narrow converters.
2. Withdraw the complete fan plate downward. The fan is connected using a connector.
3. Replace the defective fan on the fan plate that has been removed.
4. Mount again in the inverse sequence.

9.4 Maintenance and service of water cooling (option)

Visual inspection

As part of the inspection of the complete system, Siemens recommends that the water cooling parts are visually inspected every 6 months and a leakage check performed.

Perform the following checks on an annual basis:

- Check that all of the hose clamps and valve connections that can be accessed are securely seated.
- Perform a visual inspection of the hoses (where these are visible) for tears, cracks or other damage.

We expect an average lifetime of 10 years for the hoses when the specified environmental conditions are complied with. Values must be taken from the documentation.

You can find further information in the documentation 4BS0698 AL for water cooling systems.

9.5 Decommissioning

The device components used have no PCB and BeO.

Dispose of the equipment in accordance with the applicable regulations and also with respect to electrolyte capacitors.

If you want to decommission a device, please contact the Service Center.

Environmental compatibility



For environmentally sustainable recycling and disposal of your old device, contact a company certified for the disposal of old electrical and electronic equipment, and dispose of the device as specified in the regulations for your particular country.

Spare parts

10.1 Non-approved spare parts

Damage due to non-authorized spare parts

Using non-approved spare parts can affect the function of the equipment and damage it. Third-party spare parts and unapproved spare parts may not meet the requirements.

- Only use spare parts that have been approved by the manufacturer.

10.2 Spare parts

To request spare parts, please contact the Siemens sales office responsible for your region. You can find an overview of the Siemens contact partners in your region here (Page 189).

Always indicate the part number and - if known - the order number of the spare part required.

You can find the order number as follows:

- The device label is attached to or next to each component. Find out which item code the required spare part has. The parts list provided specify the part number and, where appropriate, the article number corresponding to the equipment identifier.
- For inquiries by email, send a photo of the product, spare part and nameplate if possible.

Use Spares on Web (www.siemens.com/sow) to obtain ordering information about spare parts.

Diagnostics, faults and warnings

For your personal safety and in order to prevent material damage it is essential that you carefully follow the instructions provided in Chapter "Safety information (Page 13)", and especially Chapter "Notes for operator protection (Page 16)". Comply with all safety-related instructions in your product documentation. Pay particular attention to the safety notices on the product itself.

Every inverter is subject to individual inspection and warm up at the factory. Therefore errors in the device during the initial commissioning can be almost ruled out. In most cases, faults usually originate from the peripherals such as incorrect wiring or missing agreement for the respective application.

The most frequent causes of errors during the initial commissioning are shown below:

Table 11- 1 Error causes and rectification

Errors	Possible causes	Fault rectification
All three LEDs on the display, i.e. "READY", "RUN" and "FAULT" are off (dark).	There is no voltage at the inverter.	Measure the control voltage at -X5 (see the order-specific customer documentation)
LED "READY" is lit. LEDs "RUN" and "FAULT" are off (dark) The inverter cannot be started.	The On command does not arrive.	Trace the path to the inverter.
	The On command you selected is not preselected.	Check the parameter assignment.
	-	Has the "Local" or "Remote" option been configured correctly?
LED "RUN" is lit. LEDs "READY" and "FAULT" are off (dark) The inverter / motor does not operate satisfactorily.	-	Have you commissioned the drive system as described in Chapter "Commissioning (Page 115)"?
	-	Perform the "Auto-Tuning" again.
LED "FAULT" is lit. LEDs "READY" and "RUN" are off (dark)	-	The error message is shown on the display in plain text. You can also invoke the event log. You can find additional information in Chapter "Reading event log (Page 188)". Siemens provides a list with all messages which are shown on the display and possible remedies on the Internet.

11.1 Reading event log

If a fault occurs, the event log of the inverter stores the following data:

- Which error has occurred?
- With parallel-connected inverters:
In which system has the fault occurred?
- Data and time of the error event
- Various actual values such as, e.g. setpoint, motor current, motor voltage, motor frequency etc.

These data are stored for the last 64 errors. The event number 01 is the most recent error.

Procedure

Read the event log using the "IMS" software.

You can also read these data on the display. Proceed as follows:

1. Press <I> and then the <down arrow> until "I-MEMORY" is shown on the screen.
2. Press <Return> to go to the first event, e.g. "I-MEMORY/01:Flt>undervoltage".
When you press <Return> again, then you can see all of the data saved for this event.
3. Press <S> to return.

Read out all data of the last event using the software "IMS" before you contact the Service Center for assistance with an error message. In this way, you significantly simplify the error localization.

Service & Support

A.1 Siemens Industry Online Support

Technical questions or additional information



If you have any technical queries or you require additional information, please contact Technical Support (<https://support.industry.siemens.com/cs/ww/en/sc/4868>).

Please have the following data ready:

- Type
- Serial number

You can find this data on the rating plate.

Online form to request support

Support Request (<https://www.siemens.com/supportrequest>)

Contact person



If you wish to request on-site service or order spare parts, please contact your local office. This office will contact the responsible service center on your behalf. You can find your contact person in the relevant contact database:

www.siemens.com/yourcontact (www.siemens.com/yourcontact)

Spare parts on the Internet

Spares on Web (www.siemens.com/sow)

Quality documents



You can find the quality documents here:

Siemens Industry Online Support (SIOS)

<https://support.industry.siemens.com/cs/ww/en/ps/13228/cert>

Technical data

Read the technical data of this device on the rating plate.

Compact units with the type designation 2T?A-0... up to 2T?A-3... have two rating plates. One of these is on the outside of the left side panel and the other is on the inside of the left side panel.

In the case of cabinet units, the rating plate is in the cabinet in which the display is installed. You can see the rating plate on the top left after opening the cabinet door.

You can find additional technical data of the inverter in the Internet with the Siemens Product Configurator (<https://www.siemens.com/spc>).

You can also find the "DT Configurator" here (www.siemens.com) using the search function.

Other lists and instructions

The following descriptions can be downloaded from the website of the manufacturer:

- Operating instructions
- Parameterization instructions
- Message text on the display, for example error messages
- Inverter Management Software (IMS)
- GSD files for PROFIBUS and PROFINET

C.1 Conformity

The SINAMICS G180 meets the requirements of the following directives:

- EMC Directive No. 2014/30/EU
- Machinery Directive 2006/42/EC
- RoHS 2 Directive No. 2011/65/EU

The CE declaration of conformity for the SINAMICS G180 is issued in line with these directives.

C.2 Technical data for transportation

Carefully observe the following environmental conditions for transport according to EN 60721-3-2:1997:

Environmental conditions when transporting the converter	
Climatic conditions	Class 2K3 acc. to EN 60721-3-2:1997
Atmospheric pressure	700 mbar ... 1060 mbar, corresponds to max. 3000 m above sea level
Ambient temperature	- 25 °C ... + 70 °C
Humidity rating	Maximum relative humidity if the temperature of the converter slowly increases by 40 K: 95 % Maximum relative humidity if the device is brought immediately from - 25 °C to + 30 °C: 95 % Maximum absolute humidity if the device is brought immediately from + 70 °C to + 15 °C: 60 g/m ³
Mechanical conditions	Class 2M2 acc. to EN 60721-3-2:1997
Vibration load	
- Deflection	3.1 mm at 5 ... 9 Hz
- Acceleration	10 m/s ² at 9 ... 200 Hz
Shock load	
- Acceleration	100 m/s ² at 11 ms
Chemical conditions	Class 2C2 acc. to EN 60721-3-2:1997
Biological conditions	Class 2B1 acc. to EN 60721-3-2:1997

C.3 Technical data for storage

Carefully observe the following environmental conditions for storage according to EN 60721-3-1:1997:

Environmental conditions when storing the converter	
Climatic conditions	Class 1K4 acc. to EN 60721-3-1:1997 for the temperature Class 1K3 acc. to EN 60721-3-1:1997 for the relative humidity
Atmospheric pressure	860 mbar ... 1060 mbar, corresponds to max. 1000 m above sea level
Ambient temperature	- 25 °C ... + 55 °C
Humidity rating	5 % ... 95 %, 1 g/m ³ ... 29 g/m ³
Mechanical conditions	Class 1M2 acc. to EN 60721-3-1:1997
Vibration load	
- Deflection	1.5 mm at 5 ... 9 Hz
- Acceleration	5 m/s ² at 9 ... 200 Hz
Shock load	
- Acceleration	40 m/s ² at 22 ms
Environmental class/ Chemical conditions	Class 1C2 acc. to EN 60721-3-1:1997
Organic/biological conditions	Class 1B1 acc. to EN 60721-3-1:1997

C.4 Technical data for operation

Make sure that the following environmental conditions for operation are fulfilled.

The converters are designed for indoor installation.

- Class 3K3 environmental conditions in accordance with EN 60721-3-3:2002
- Pollution degree 2
- Overvoltage category 3
- Degree of protection IP20 for compact units
- Degree of protection IP21 for cabinet units

Environmental conditions when operating the converter	
Climatic conditions	Class 3K3 acc. to EN 60721-3-3:2002
Atmospheric pressure	860 mbar ... 1060 mbar, corresponds to max. 1000 m above sea level ¹⁾
Ambient temperature	0 °C ... + 40 °C ¹⁾
Humidity rating	5 % ... 95 %, 1 g/m ³ ... 25 g/m ³
Mechanical conditions	Class 3M4 acc. to EN 60721-3-3:2002
Vibration load	
- Deflection	0.075 mm at 10 ... 58 Hz
- Acceleration	10 m/s ² at 58 ... 200 Hz
Shock load	
- Acceleration	100 m/s ² at 11 ms
Chemical conditions	Class 3C2 acc. to EN 60721-3-3:2002
Biological conditions	Class 3B1 acc. to EN 60721-3-3:2002

¹⁾ The units can be operated under different environmental conditions if derating is applied.

For further information, refer to Chapter "Derating (Page 206)".

For further technical data, refer to the technical data sheet.

C.5 Frame sizes of compact units

Please refer to the following diagrams and tables for the frame size of your converter.

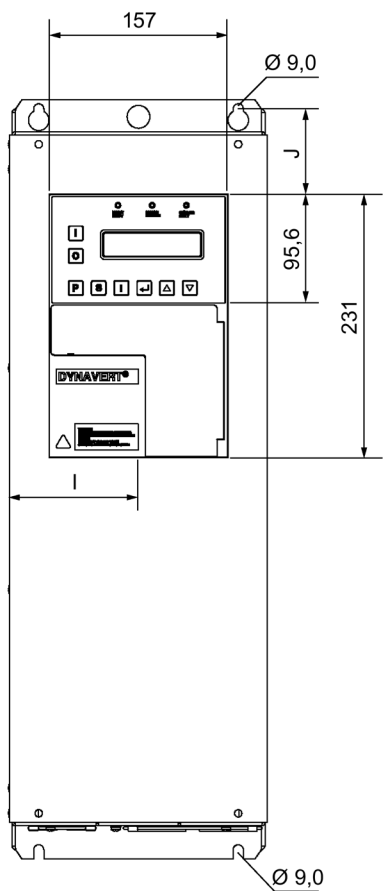

Compact device 1 dimension drawing

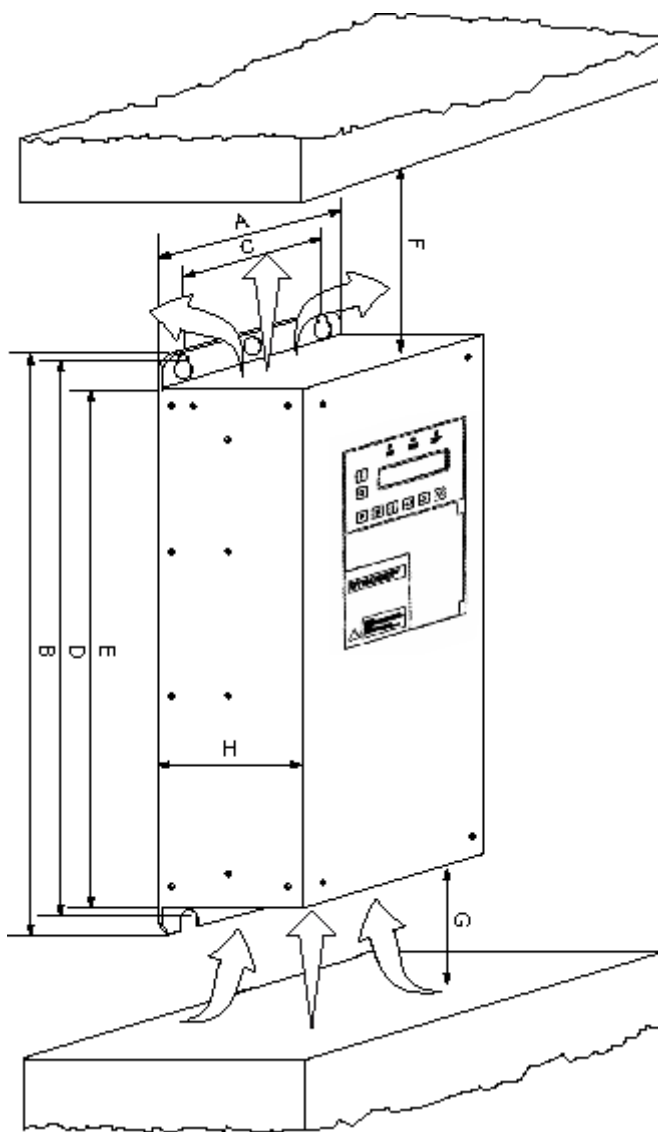

Compact device 2 dimension drawing

Table C- 1 Dimensions of the different converters in mm

Converter type	A	B	C	D	E	F ¹⁾	G ²⁾	H	I	J	BG ³⁾
2T2A-07400-002 ... 2T2A-07400-005 2T2A-07500-002 ... 2T2A-07500-007	165	465	125	450	410	100	200	320	82.5	22.5	BG K1
2T2A-07400-007 ... 2T2A-07400-011 2T2A-07500-011 ... 2T2A-07500-015	165	565	125	550	510	100	200	320	82.5	22.5	BG K2
2T2A-07400-015 ... 2T2A-07400-030 2T2A-07500-022 ... 2T2A-07500-037 2T2A-07600-007 2T2A-07600-011 2T2A-07600-015 2T2A-07600-022	225	665	175	650	610	100	200	320	112.5	75	BG K3
2T2A-07400-037 ... 2T2A-07400-055 2T2A-07500-045 ... 2T2A-07500-075 2T2A-07600-030 ... 2T2A-07600-075	350	775	300	750	710	100	200	320	255	70	BG K4
2T2A-07400-075 ... 2T2A-07400-110 2T2A-07500-090 ... 2T2A-07500-132 2T2A-07600-090 ... 2T2A-07600-132	350	1,125	300	1,100	1,060	100	200	320	255	70	BG K5
2T2A-27400-075 ... 2T2A-27400-110 2T2A-27500-090 ... 2T2A-27500-132 2T2A-27600-090 ... 2T2A-27600-132	350	1,538	300	1,490	1,460	100	200	345	255	70	BG K51
2T2A-07400-132 ... 2T2A-07400-160 2T2A-07500-160 ... 2T2A-07500-200 2T2A-07600-160 ... 2T2A-07600-200	500	1,125	400	1,100	1,060	100	200	320	405	70	BG K6

1) F = cooling air discharge area: Do not block this area.

2) G = cooling air intake area: Do not block this area.

3) BG = frame size

C.6 Frame sizes of cabinet units

Please refer to the following table for the frame size of your converter.

Table C- 2 Converter types and associated frame sizes

Converter type	Frame size
2R3A-87400-030 ... 2R3A-87600-030	FS S1
2T3A-87401-200 ... 2T3A-87401-315	FS S2
2T3A-87501-250 ... 2T3A-87501-400	
2T3A-87601-250 ... 2T3A-87601-400	
2R3A-87400-055 ... 2R3A-87600-055	
2T3A-87401-400	FS S21
2T3A-87501-500	
2T3A-87601-500	
2T3A-87401-500 ... 2T3A-87401-630	FS S3
2T3A-87501-560 ... 2T3A-87501-800	
2T3A-87601-560 ... 2T3A-87601-910	

The corresponding dimension drawings can be found in the following illustrations.

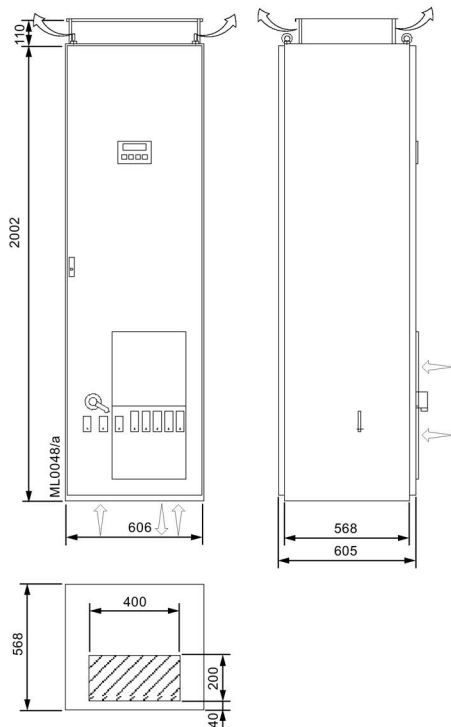

Figure C-1 Dimension drawing FS S1

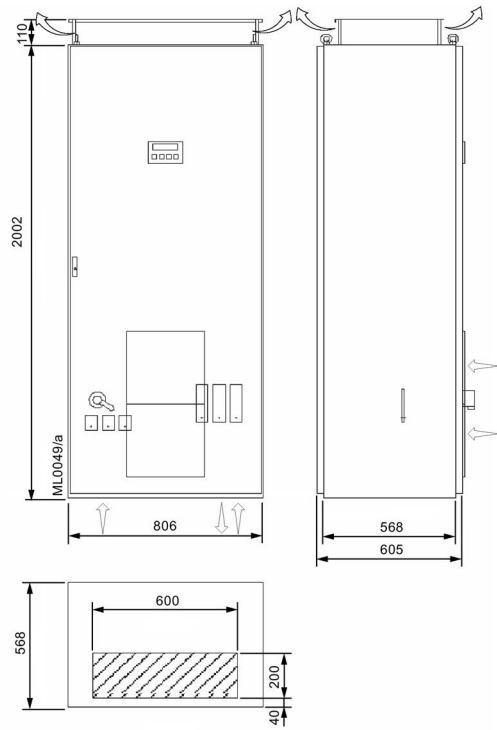

Figure C-2 Dimension drawing FS S2

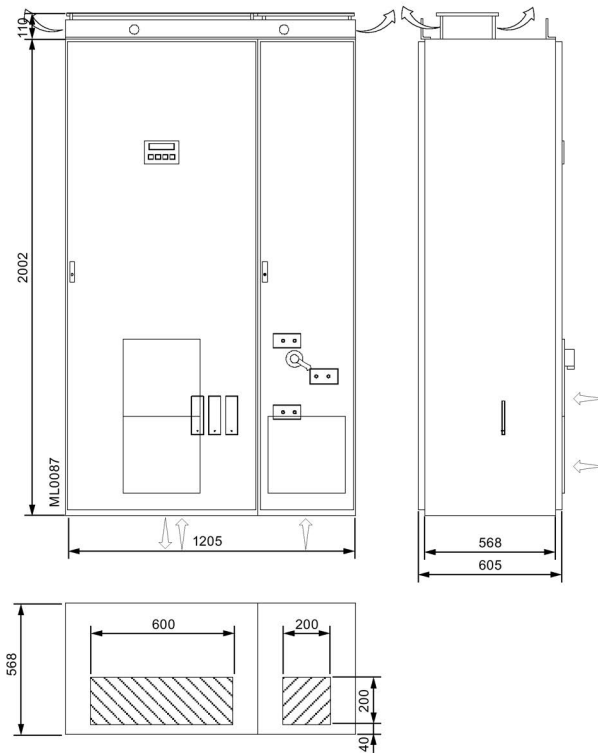

Figure C-3 Dimension drawing FS S21

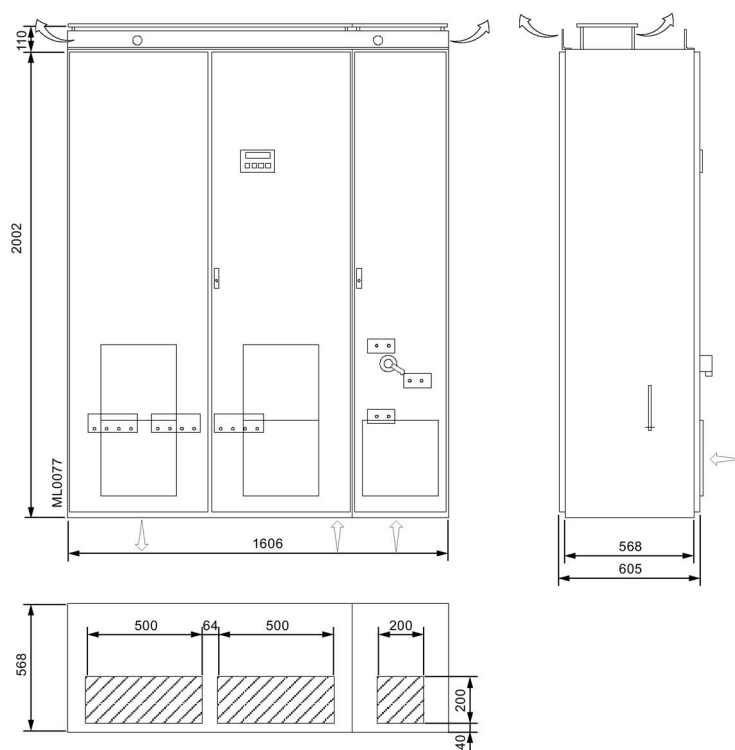

Figure C-4 Dimension drawing FS S3

C.7 Tightening torques for power cables

Please refer to the table below for the torques for tightening power cable connections.

Observe the information in Chapter "Electrical connection (Page 91)".

Table C-3 Tightening torques for terminal and lug connections

Terminal UK6N, 8.2 mm wide	Terminal UK35, 15.2 mm wide	M6	M8	M10	M12	M16
1.5 ... 1.8 Nm	3.2 ... 3.7 Nm	9 Nm	22 Nm	44 Nm	75 Nm	106 Nm

Table C-4 Tightening torques for switch and contactor connections

M3 / 3.5	M4	M6	M8	M10	M12
1.2 Nm	1.8 Nm	4 Nm	6 Nm	20 Nm	45 Nm

C.8 Technical data of the control cable terminals

Red pins avoid mixing up the connectors. The control cable terminals are plug-in connections. You can unplug the plugged-in connections when disconnected from the power supply.

When selecting cables and conductors and installing them, it is essential that you observe the information provided in Chapter "Connecting control cable (Page 93)" and "Protective separation according to EN 61800-5-1 (Page 145)".

The control cable terminals are color-coded:

- The green terminals on the far left contain all relay outputs and the optocoupler inputs at a separate potential.
- The black terminals contain the potential-free analog inputs and digital inputs which are electrically separated the same as the analog inputs.
- The white terminals contain the electrically separated analog outputs.

All external voltages can be connected together for controlling a PCS or PLC. To do this, jumper the ground terminals -X2:1 with -X2:51 and -X2:51 with -X2:71.

If you control the inverter using different devices, potential displacements occur which depend on the cable length used. Remove the jumpers for longer cables.

Technical data of the control cable terminals	
Conductor cross-section -X2	rigid / flexible: 0.5 mm ² ... 2.5 mm ²
Relay outputs -X2:30 ... 42	5 V ... 250 V AC / 1 A, 15 AC 5 V ... 30 V DC / 1 A > 30 V ... 60 V DC / 120 mA > 60 V ... 250 V DC / 60 mA
With peripheral board 3 or 4 only: Relay outputs -X2:43 ... 49	Minimum switching load: 12 V / 100 mA
Digital inputs -X2:8 ... 16	Low: -3 V ... +5 V High: 13 V ... 32 V Floating Typically 12 mA for High
Digital input safe torque off (only with peripheral board 3 or 4): -X2:20	Low: -3 V ... +5 V High: 13 V ... 32 V Floating Typically 12 mA for High Response time: ≤ 5 ms
Analog inputs -X2:50 ... 53	Voltage input 0 V ... ± 10 V, 200 kΩ Terminal 52 and 54 or current input 0 mA or 4 mA ^{*)} ... ± 20 mA, 100 Ω, Terminals 50 and 53
Supply voltages on potential of the analog inputs for diverse sensors:	Terminal 55: 24 V DC, max. 300 mA Terminal 56: 15 V DC, max. 150 mA Terminal 57: 10 V DC, max. 10 mA Terminal 58: -10 V DC, max. 10 mA
Digital inputs -X2:27, 28	Low: -3 V ... +5 V High: 13 V ... 32 V Floating on potential of the analog inputs Typically 2.4 mA for High Direct connection of PTC thermistors Reference potential for PTC thermistor: Terminal -X2:58 (-10 V). The voltage over the PTC thermistor is approx. 2.5 V Can also be used as f or n input.
Digital input -X2:29	Low: -3 V ... +5 V, high: 13 V ... 32 V Floating on potential of the analog inputs, typically 2.4 mA for High Can also be used as f or n input
Analog outputs -X2:60 ... 63	With automatic changeover current or voltage, floating: Load < 300 Ω: 0 mA or 4 mA ^{*)} ... 20 mA Load > 1 kΩ: 0 V ... 10 V
Supply voltages on potential of the analog outputs:	Terminal 70: 24 V DC, max. 300 mA

^{*)} 0 mA or 4 mA can be parameterized.

C.9 Technical data and identification of the PTC thermistor input at peripheral boards 2 and 4

PTC thermistor input - Data	
Application	For temperature monitoring of explosion-protected motors, type of protection "Increased safety" EX e according to DIN EN 50019 VDE 0170/0171 and "Flameproof enclosure" Ex d according to DIN EN 50018 VDE 0170/0171 as well as normal motors installed outside hazardous zones
Identification	 II (2) G [Ex db Gb] [Ex eb Gb] [Ex pxb Gb] II (2) D [Ex tb Db] [Ex pxb Db]
maximum number of sensors	6 sensors according to DIN VDE 0660 Part 303
OK state	< 1.5 kΩ ... 1.8 kΩ
Overtemperature message	> 3.2 kΩ ... 3.8 kΩ
Short-circuit in the sensor circuit	< 15 Ω ... 25 Ω
Measuring circuit load	< 5 mW for R = 1.5 kΩ
Voltage in the sensor circuit	< 2 V for R = 1.5 Ω
Current in the sensor circuit	< 1.5 mA for R = 1.5 kΩ
Voltage for measuring sensor break	11.6 V
Current for short-circuited sensor circuit	1.45 mA
Response time	≤ 75 ms
Electrical design	Safe isolation for 690 V from the other switching circuits according to EN 50178, EN 61800-5-1
Maximum cable length for PTC thermistor sensor circuit:	
Cross-section 2.5 mm ²	2 × 500 m
Cross-section 1.5 mm ²	2 × 300 m
Cross-section 0.5 mm ²	2 × 100 m

You can use the PTC input to monitor motors in the hazardous zones. It is not permissible that the converter itself is installed in a hazardous zone.

The PTC thermistor evaluation function can be deactivated by an internal switch. For this reason, perform the test described in Chapter "PTC inputs for motor PTC thermistor (Page 47)". If the result of the test is negative, contact the Service Center for advice.

C.10 Technical data of the direct water cooling

Technical data

Inverter type	Frame size
2T3A-77401-200 ... 2T3A-77401-315	BG S2
2T3A-77501-250 ... 2T3A-77501-400	
2T3A-77601-250 ... 2T3A-77601-400	
2T3A-77401-400	BG S21
2T3A-77501-500	
2T3A-77601-500	
2T3A-77401-500 ... 2T3A-77401-630	BG S3
2T3A-77501-560 ... 2T3A-77501-800	
2T3A-77601-560 ... 2T3A-77601-910	

If you connect several inverters in parallel, the technical data is multiplied according to the number of systems. The water flow rate for type 2T 6 A-7 5 69 4-925 with four inverter systems is e.g. 4×2000 l/h.

The water-cooled units BG S1 to BG S21 have the same cabinet width as the air-cooled units.

In the case of units with frame size S3, the cabinet width when compared to the air-cooled version increases as follows:

Increased cabinet width for water cooling	
Units with one system	200 mm
Units with two or three systems	400 mm
Units with four systems	600 mm

Water cooling - Ambient conditions

Frame size	BG S2, BG S21, BG S3
Degree of protection	IP55 IP54 with operator panel in the door
Water quality	Industrial water, see Chapter "Permissible substance values for the cooling water (Page 205)"
Permissible coolant temperature	+10 °C ... +25 / 30°C (depends on the power, see inverter documentation)
Permissible ambient temperature	In operation: +1 °C ... +55 °C

Water cooling - Water pressure and amount of water

Frame size	BG S2	BG S2/21	BG S3
Water flow rate [l/h]	720	1200	2000
Min. operating pressure [bar]	1	1	2.5
Max. operating pressure [bar]	6	6	6
Pressure loss [approx. bar]	0.5	0.7	1.4
Test pressure [bar]	10	10	10

C.11 Permissible substance values for the cooling water

Water cooling - Connection hoses			
Frame size	BG S2	BG S2/21	BG S3
Inlet DN "...^..."	13 ^ 1/2 "	13 ^ 1/2 "	19 ^ 3/4 "
Return DN "...^..."	13 ^ 1/2 "	13 ^ 1/2 "	19 ^ 3/4 "
Venting DN "...^..."	13 ^ 1/2 "	13 ^ 1/2 "	13 ^ 1/2 "
Cabinet height [mm]	2000	2200	2200

C.11 Permissible substance values for the cooling water

Permissible substance values for the cooling water (process water and de-ionized water) for inverter cooling with open standard cooling without a cooling system.

Material: Stainless steel, material number: 1.4301; 1.4571

	Permissible values for stainless steel material
Water temperature	+10 ... +30 (+35) °C
pH value	7 ... 8
Total hardness	6 ... 20 °dH
Carbonate hardness	3 ... 10 °dH
Total dissolved solids 105 °C	< 500 mg / l
Free carbon dioxide	< 1 mmol / l
Chlorides	< 150 mg / l
Sulfates	500 mg / l
Nitrates	< 10 mg / l
Nitrites	0 mg / l
Phosphates	< 0.5 mg / l
Ammonium NH4	< 0.5 mg / l
Ammonia	0 mg / l
Silicon (SiO2 crystalline)	< 10 mg / l
Free CO2 (p value)	< 15 mg / l
Iron	< 0.2 mg / l
Hydrogen sulfide	< 1 mg / l
Suspended solids < 50 µm	< 10 mg / l
Conductivity	< 3000 µS/cm
Oxygen	8 ... 12 mg / l

C.12 Threshold values for fan control system

The fan control system detects the three following states: OFF, SLOW and FAST.

- OFF: The fans are OFF if the unit is not switching and all relevant temperatures are below the thresholds for FAST.
- SLOW: The fans operate slowly if the unit is turned on (= is switching) and all relevant temperatures are below the thresholds for FAST.
- FAST: The fans operate fast if one of the relevant temperatures is higher than the threshold for FAST irrespective of whether or not the unit is turned on.

Table C- 5 Threshold values for fan control system

Fan	fast	slow	off
Clock enable	--	Yes	No
Parameter "P-INVERTER DATA/fan"	= fast	= slow	= T-contrl.
Reactor prewarning	Yes	No	No
"T-CPU"	$\geq 70\text{ °C}$	$\leq 70\text{ °C} (-5\text{ °C})$	$\leq 50\text{ °C} (-5\text{ °C})$
"T-cabin. max"	$\geq 47\text{ °C}$	$\leq 47\text{ °C} (-5\text{ °C})$	$\leq 10\text{ °C} (-5\text{ °C})$
"T-heat max"	$\geq 50\text{ °C}$	$\leq 50\text{ °C} (-10\text{ °C})$	$\leq 10\text{ °C} (-5\text{ °C})$
"T-diff. max"	$\geq 7 / 9\text{ °C}^{1)}$	$\leq 7 / 9\text{ °C}^{1)} (-2\text{ °C})$	$\leq 7 / 9\text{ °C}^{1)} (-2\text{ °C})$
"T-rectif. max"	$\geq 55\text{ °C}$	$\leq 55\text{ °C} (-5\text{ °C})$	$\leq 55\text{ °C} (-5\text{ °C})$

1) Air/water cooled

() Where relevant, values in brackets should be seen as switching hysteresis.

C.13 Derating

C.13.1 Current derating

The devices and the associated system components are rated for an ambient temperature of 40 °C and installation altitudes of up to 1000 m above sea level.

The following tables specify the permissible output currents as a function of the installation altitude and ambient temperature.

Note also the information in Chapter "Voltage derating (Page 209)".

Table C- 6 Current derating for air-cooled inverters

Installation altitude above sea level in m	Current derating factor in % of rated current							
	20 °C	25 °C	30 °C	35 °C	40 °C	45 °C	50 °C	55 °C ¹⁾
0 ... 1000	100 %	100 %	100 %	100 %	100 %	87.5 %	75.0 %	62.5 %
1001 ... 1500	100 %	100 %	100 %	100 %	94.4 %	82.6 %	70.8 %	59.0 %
1501 ... 2000	100 %	100 %	99.4 %	94.3 %	88.9 %	77.8 %	66.7 %	55.6 %
2001 ... 2500 ²⁾	100 %	97.7 %	93.2 %	88.4 %	83.3 %	72.9 %	62.5 %	52.1 %
2501 ... 3000 ²⁾	95.3 %	91.2 %	87.0 %	82.5 %	77.8 %	68.1 %	58.3 %	48.6 %
3001 ... 3500 ²⁾³⁾	89.8 %	86.0 %	82.0 %	77.8 %	73.3 %	64.2 %	55.0 %	45.8 %
3501 ... 4000 ²⁾³⁾	84.4 %	80.8 %	77.0 %	73.1 %	68.9 %	60.3 %	51.7 %	43.1 %
4001 ... 4500 ²⁾³⁾	78.9 %	75.6 %	72.1 %	68.4 %	64.4 %	56.4 %	48.3 %	40.3 %
4501 ... 5000 ²⁾³⁾	73.5 %	70.4 %	67.1 %	63.6 %	60.0 %	52.5 %	45.0 %	37.5 %

1) Applies only to compact devices which are not installed in a cabinet

2) Voltage derating must also be implemented for compact devices at an installation altitude of > 2000 m.

3) Voltage derating must also be implemented for cabinet units at an installation altitude of > 3000 m.

The following current derating values apply to water-cooled inverters. Refer to the technical data sheet for the maximum water intake temperature.

Table C- 7 Current derating for water-cooled inverters with a maximum water intake temperature of 28 °C

Installation altitude above sea level in m	Current derating factor in % of rated current				
	18 °C	23 °C	28 °C	33 °C	38 °C
0 ... 1000	100 %	100 %	100 %	84.0 %	64.2 %
1001 ... 1500	100 %	100 %	94.4 %	79.3 %	60.6 %
1501 ... 2000	100 %	100 %	88.9 %	74.7 %	57.0 %
2001 ... 2500	100 %	94.8 %	83.3 %	70.0 %	53.5 %
2501 ... 3000	98.0 %	88.5 %	77.8 %	65.3 %	49.9 %
3001 ... 3500 ¹⁾	92.4 %	83.4 %	73.3 %	61.6 %	47.1 %
3501 ... 4000 ¹⁾	86.8 %	78.4 %	68.9 %	57.9 %	44.2 %
4001 ... 4500 ¹⁾	81.2 %	73.3 %	64.4 %	54.1 %	41.4 %
4501 ... 5000 ¹⁾	75.6 %	68.3 %	60.0 %	50.4 %	38.5 %

1) Voltage derating must also be implemented for cabinet units at an installation altitude of > 3000 m.

C.13 Derating

Table C- 8 Current derating for water-cooled inverters with a maximum water intake temperature of 30 °C

Installation altitude above sea level in m	Current derating factor in % of rated current				
	20 °C	25 °C	30 °C	35 °C	40 °C
0 ... 1000	100 %	100 %	100 %	81.6 %	57.7 %
1001 ... 1500	100 %	100 %	94.4 %	77.1 %	54.5 %
1501 ... 2000	100 %	100 %	88.9 %	72.6 %	51.3 %
2001 ... 2500	100 %	96.2 %	83.3 %	68.0 %	48.1 %
2501 ... 3000	100 %	89.8 %	77.8 %	63.5 %	44.9 %
3001 ... 3500 ¹⁾	94.7 %	84.7 %	73.3 %	59.9 %	42.3 %
3501 ... 4000 ¹⁾	88.9 %	79.5 %	68.9 %	56.2 %	39.8 %
4001 ... 4500 ¹⁾	83.2 %	74.4 %	64.4 %	52.6 %	37.2 %
4501 ... 5000 ¹⁾	77.5 %	69.3 %	60.0 %	49.0 %	34.6 %

¹⁾ Voltage derating must also be implemented for cabinet units at an installation altitude of > 3000 m.

Table C- 9 Current derating for water-cooled inverters with a maximum water intake temperature of 35 °C

Installation altitude above sea level in m	Current derating factor in % of rated current			
	25 °C	30 °C	35 °C	40 °C
0 ... 1000	100 %	100 %	100 %	70.7 %
1001 ... 1500	100 %	100 %	94.4 %	66.8 %
1501 ... 2000	100 %	100 %	88.9 %	62.9 %
2001 ... 2500	100 %	100 %	83.3 %	58.9 %
2501 ... 3000	100 %	95.3 %	77.8 %	55.0 %
3001 ... 3500 ¹⁾	100 %	89.8 %	73.3 %	51.9 %
3501 ... 4000 ¹⁾	97.4 %	84.4 %	68.9 %	48.7 %
4001 ... 4500 ¹⁾	91.1 %	78.9 %	64.4 %	45.6 %
4501 ... 5000 ¹⁾	84.9 %	73.5 %	60.0 %	42.4 %

¹⁾ Voltage derating must also be implemented for cabinet units at an installation altitude of > 3000 m.

C.13.2 Voltage derating

The compact units are designed according to minimum air clearances at up to 2000 m above sea level, and the cabinet units according to minimum air clearances at up to 3000 m above sea level. Derating is only required above altitudes of 2000 m respectively 3000 m above sea level (only applicable for the basic unit ¹⁾).

Since the air clearances in the converter cannot be changed, this factor must be taken into account in the voltage derating calculation.

Table C- 10 Voltage derating for compact units

Installation altitude above sea level in m	Voltage derating factor in % of rated voltage
0 ... 2000	100 %
2001 ... 2500	93.4 %
2501 ... 3000	87.7 %
3001 ... 3500	81.9 %
3501 ... 4000	77.5 %
4001 ... 4500	71.9 %
4501 ... 5000	67.6 %

Table C- 11 Voltage derating for cabinet units (is only applicable for the basic device ¹⁾)

Installation altitude above sea level in m	Voltage derating factor in % of rated voltage
0 ... 3000	100 %
3001 ... 3500	93.9 %
3501 ... 4000	88.5 %
4001 ... 4500	82.4 %
4501 ... 5000	77.0 %

¹⁾ When installing options, it is possible that the permissible installation altitude is further restricted, or a voltage derating results in a lower value. This must be checked on a case-by-case basis.

List of abbreviations

ARM	"Acorn Risc Machine": Microprocessor architecture
ATEX	"Atmosphère explosible": Synonym for the EC directive for explosion protection ATEX product directive 2014/34/EU
ASM	Induction machine
BeO	beryllium oxide: toxin. Relevant for the disposal
BGR	Health and safety at work regulations
BGV	Regulations of the German Trade Association
CD	"Compact Disc": Optical storage medium for digital storage of music and data.
CB08	Control electronics board
DASM	Dual-fed induction machine
DIL	"Dual In-Line Package": Type of packaging (Package) for electronic components
DSP	Digital signal processor
DVC	"Decisive Voltage Class": Classification of the voltage range used to determine protective measures against electric shock hazards
ESD	Electrostatically Sensitive Devices
EMF	Electromotive force
EMC	Electromagnetic compatibility
EN	"Europäische Norm": European standards are rules that have been ratified by one of the three European standardization committees.
Ex	Explosion-proof area
FOC	Field-oriented control
FRT	"Fault Ride Trough":
FI	Frequency inverter
GSD	"General Station Description", original "device master data": One data format for PROFIBUS and PROFINET devices
IEC	"International Electrotechnical Commission": Standards committee for electrical engineering
HVRT	"High Voltage Ride Trough":
IGBT	"Insulated Gate Bipolar Transistor": Type of power semiconductor
IMS	"Inverter Management Software": You can also parameterize the inverter with this software using a PC, save parameter sets, etc. You can download the software at no cost from the manufacturer's website.
LED	"Light Emitting Diode", Light Emitting Diode
LHF	"Line Harmonics Filter": Reduces the low-frequency line harmonics of 6-pulse rectifier circuits
LSB	"Least Significant Bit": Least significant bit of a binary number
LVRT	"Low Voltage Ride Trough": A voltage dip is ridden through
MLFB	"Maschinenlesbare Fabrikate Bezeichnung": Product Order No.
MSB	"Most Significant Bit": Most significant bit of a binary number
MSC	Machine-side converter
NAMUR	originally "Normenarbeitsgemeinschaft für Meß- und Regeltechnik in der chemischen Industrie": International user association for automation in the process industry
NC	"Normally Closed", NC contact
NO	"Normally Opened", NO contact
LSC	Line-side converter

List of abbreviations

NRTL	"Nationally Recognized Testing Laboratory": American testing facilities that provide product safety testing and certification services to manufacturers
NYN, NYCWW	Cable types
PCB	polychlorinated biphenyls: toxins. Relevant for the disposal.
PELV	"Protective Extra Low Voltage", protective extra-low voltage (PELV). previously function extra-low voltage with safe isolation
PMM	permanent magnet machine
PERM	Permanent-magnet synchronous motors
PL	Specification of the Performance Level according to DIN EN ISO 13849-1:2015
PCS	Process control system
PPO	Parameter process data object: Part of a PROFIBUS profile
PTC	"Positive Temperature Coefficient", Positive Temperature Coefficient: PTC thermistor
RS 232, RS 485, RS 422	standards for serial interfaces
RTU	"Remote Terminal Unit": Remote terminal unit
SELV	"Safety Extra Low Voltage": Safety extra low voltage
PLC	Programmable Logic Controller
STW	Control word
Sub-D	Actually "D-Sub": common type of a connector system for data connections
SVC	"Space Vector Control": space vector modulation, a technique to control rotating electrical machinery based on pulse width modulation.
TCP	"Transmission Control Protocol": a network protocol
TÜV	"Technischer Überwachungsverein": A body that carries out technical safety checks as prescribed by national laws or regulations
UL	"Underwriters Laboratories": certification organization for product safety in the USA
USB	"Universal Serial Bus": Serial bus system
UPS	Uninterruptible power supply
VDE	Association for Electrical, Electronic & Information Technologies
De-ionized water	Fully de-ionized water
ZLU	Supplementary supply agreements for converter drives in power plants
ZSW	Status word

Index

A

- Analog inputs, 160
- Analog outputs, 131
- Antifreeze
 - First aid measures, 21
- Application
 - Factory settings, 50

B

- Brake transistor, 49
- Braking resistor, 49

C

- Canopy, 51, 85
- Commissioning, 115
- Components that can be destroyed by electrostatic discharge (ESD)
 - Guidelines, 24
- Configuration, 165
- Connecting the control cables, 93
- Connection
 - external control voltage, 102
 - Line supply, 93
 - Motor, 98
- Contactors functions, 156
- Control cable terminals, 145, 201
 - Namur, 176
 - Standard, 169
- Control voltage, 102
 - Protecting, 28, 103
- Coolant
 - Safety precautions, 20
- Cooling water, 205
 - Additives, 69

D

- DC link terminals, 52
- Default setting, 50

Derating, 206

- Current derating, 206
 - Derating according to installation altitude, 206
 - Temperature derating, 206
 - Voltage derating, 209
- ## Digital inputs, 161
- ## Digital outputs, 130
- ## Display, 123
- External, 54
 - installing, 88
- ## Disposal, 184
- ## DMZ network, 134
- ## du/dt filter, 55

E

- Electrical installation, 92
- electronic shutdown, 38
- Erroneous pulses, 27, 28
- external control voltage, 102
- external display, 54, 88

F

- Fan, 206
- Fiber-optic cables, 28
- Filter
 - du/dt, 55
 - Mains power protection, 55
 - RFI suppression, 55
 - Sinusoidal, 55
- Firewall, 134
- First aid
 - Antifreeze, 21
- Five safety rules, 13
- Flashlight, 28
- Fuse, 92

G

- Grounding
 - ESD shoe grounding strips, 25

I

Inputs

- Analog, 160
- Digital, 161

Installation, 83

- Cabinet unit, 86
- Compact unit, 84
- Electrical, 92
- external display, 88
- Mechanical, 83

M

- Main switches, 52
- Mains connection, 93
- Mains power protection choke, 55
- Maintenance, 181, 181
- MLFB, 31
- Mobile telephones, 27
- Modbus board, 60, 63
- Motor connection, 98

O

- On-site service, 189
- Operation, 123
- Operation settings
 - NAMUR, 138
 - Standard, 135
- Order number, 31
- Outputs
 - Analog, 131
 - Digital, 130

P

- Parameter
 - Overview, 50
- PROFIBUS board, 56
- PROFINET board, 57
- Protecting the converter, 92
- Protection zone, 134
- PTC inputs, 47
- PTC thermistor inputs, 47

R

- Radio telephones, 27
- Recycling, 184
- RFI suppression filter, 55

S

- Safe torque off, 38, 42
- Safety precautions
 - Coolant, 20
- Safety rules, 13
- Setpoint source, 164
- Setting mains voltage, 96
- shutdown, electronic, 38
- Sine-wave filter, 55
- Software
 - Update, 31
- Spare parts, 189, 189
 - Contact person, 185
 - Spares On Web, 185
- Storage, 74
- Switch disconnectors, 52

T

- Technical data
 - Control cable terminals, 201
 - Inverter, 193
- Technical Support, 189
- Threshold values
 - Fan, 206
- Transport, 71
- Type code, 31
- Type designation, 31

W

- Water cooling, 66, 67
 - Maintenance, 183
 - Technical data, 204

More information

Siemens:
www.siemens.com

Industry Online Support (service and support):
www.siemens.com/online-support

IndustryMall:
www.siemens.com/industrymall

Siemens AG
Digital Industries
Motion Control
Postfach 3180
91050 Erlangen
Germany

Scan the QR-Code
for product
information

