

# SIEMENS

## SINAMICS

### SINAMICS V20 Inverter

#### Operating Instructions

#### Preface

---

#### Safety instructions

---

1

#### Introduction

---

2

#### Mechanical installation

---

3

#### Electrical installation

---

4

#### Commissioning

---

5

#### Communicating with the PLC

---

6

#### Parameter list

---

7

#### Faults and alarms

---

8

#### Technical specifications

---

A

#### Options and spare parts



---

B

## Legal information

### Warning notice system

This manual contains notices you have to observe in order to ensure your personal safety, as well as to prevent damage to property. The notices referring to your personal safety are highlighted in the manual by a safety alert symbol, notices referring only to property damage have no safety alert symbol. These notices shown below are graded according to the degree of danger.

 <b>DANGER</b>
indicates that death or severe personal injury <b>will</b> result if proper precautions are not taken.
 <b>WARNING</b>
indicates that death or severe personal injury <b>may</b> result if proper precautions are not taken.
 <b>CAUTION</b>
indicates that minor personal injury can result if proper precautions are not taken.
<b>NOTICE</b>
indicates that property damage can result if proper precautions are not taken.

If more than one degree of danger is present, the warning notice representing the highest degree of danger will be used. A notice warning of injury to persons with a safety alert symbol may also include a warning relating to property damage.

### Qualified Personnel

The product/system described in this documentation may be operated only by **personnel qualified** for the specific task in accordance with the relevant documentation, in particular its warning notices and safety instructions. Qualified personnel are those who, based on their training and experience, are capable of identifying risks and avoiding potential hazards when working with these products/systems.

### Proper use of Siemens products

Note the following:

 <b>WARNING</b>
Siemens products may only be used for the applications described in the catalog and in the relevant technical documentation. If products and components from other manufacturers are used, these must be recommended or approved by Siemens. Proper transport, storage, installation, assembly, commissioning, operation and maintenance are required to ensure that the products operate safely and without any problems. The permissible ambient conditions must be complied with. The information in the relevant documentation must be observed.

### Trademarks

All names identified by ® are registered trademarks of Siemens AG. The remaining trademarks in this publication may be trademarks whose use by third parties for their own purposes could violate the rights of the owner.

### Disclaimer of Liability

We have reviewed the contents of this publication to ensure consistency with the hardware and software described. Since variance cannot be precluded entirely, we cannot guarantee full consistency. However, the information in this publication is reviewed regularly and any necessary corrections are included in subsequent editions.

# Preface

## Purpose of this manual

This manual provides you with information about the proper installation, commissioning, operation, and maintenance of SINAMICS V20 inverters.

## SINAMICS V20 user documentation components

Document	Content	Available languages
Operating Instructions	(this manual)	English Chinese French German Italian Korean Portuguese Spanish
Getting Started	Describes how you install, operate, and perform basic commissioning of the SINAMICS V20 inverter	English Chinese French German Italian Korean Portuguese Spanish
Product Information	Describes how you install and operate the following options or spare parts: <ul style="list-style-type: none"><li>• Parameter Loaders</li><li>• Dynamic Braking Modules</li><li>• External Basic Operator Panels (BOPs)</li><li>• BOP Interface Modules</li><li>• Shield Connection Kits</li><li>• Replacement Fans</li></ul>	English Chinese

## Technical support

Country	Hotline
China	+86 400 810 4288
France	+33 0821 801 122
Germany	+49 (0) 911 895 7222
Italy	+39 (02) 24362000
Brazil	+55 11 3833 4040
India	+91 22 2760 0150
Korea	+82 2 3450 7114
Turkey	+90 (216) 4440747
United States of America	+1 423 262 5710
Further service contact information: Support contacts ( <a href="http://support.automation.siemens.com/WW/view/en/16604999">http://support.automation.siemens.com/WW/view/en/16604999</a> )	



# Table of contents

	<b>Preface</b> .....	<b>3</b>
<b>1</b>	<b>Safety instructions</b> .....	<b>9</b>
1.1	Fundamental safety instructions .....	9
1.1.1	General safety instructions .....	9
1.1.2	Safety instructions for electromagnetic fields (EMF) .....	13
1.1.3	Handling electrostatic sensitive devices (ESD) .....	13
1.1.4	Industrial security .....	14
1.1.5	Residual risks of power drive systems.....	15
1.2	Additional safety instructions .....	17
<b>2</b>	<b>Introduction</b> .....	<b>21</b>
2.1	Components of the inverter system .....	21
2.2	Inverter rating plate .....	23
<b>3</b>	<b>Mechanical installation</b> .....	<b>25</b>
3.1	Mounting orientation and clearance.....	25
3.2	Cabinet panel mounting (frame sizes A to E) .....	26
3.3	SINAMICS V20 Flat Plate variant .....	28
3.4	Push-through mounting (frame sizes B to E).....	30
3.5	DIN rail mounting (frame sizes A to B) .....	33
<b>4</b>	<b>Electrical installation</b> .....	<b>37</b>
4.1	Typical system connections .....	37
4.2	Terminal description.....	40
4.3	EMC-compliant installation .....	45
4.4	EMC-compliant cabinet design .....	47
<b>5</b>	<b>Commissioning</b> .....	<b>49</b>
5.1	The built-in Basic Operator Panel (BOP).....	49
5.1.1	Introduction to the built-in BOP .....	49
5.1.2	Inverter menu structure .....	51
5.1.3	Viewing inverter status.....	53
5.1.4	Editing parameters.....	53
5.1.5	Screen displays.....	56
5.1.6	LED states .....	58
5.2	Checking before power-on.....	58
5.3	Setting the 50/60 Hz selection menu .....	59
5.4	Starting the motor for test run .....	60
5.5	Quick commissioning .....	60

5.5.1	Quick commissioning through the setup menu .....	60
5.5.1.1	Structure of the setup menu.....	60
5.5.1.2	Setting motor data.....	62
5.5.1.3	Setting connection macros.....	63
5.5.1.4	Setting application macros.....	75
5.5.1.5	Setting common parameters.....	78
5.5.2	Quick commissioning through the parameter menu .....	79
5.6	Function commissioning .....	81
5.6.1	Overview of inverter functions.....	81
5.6.2	Commissioning basic functions.....	83
5.6.2.1	Selecting the stop mode .....	83
5.6.2.2	Running the inverter in JOG mode .....	86
5.6.2.3	Setting the voltage boost .....	87
5.6.2.4	Setting the PID controller .....	89
5.6.2.5	Setting the braking function .....	91
5.6.2.6	Setting the ramp time.....	100
5.6.2.7	Setting the I <sub>max</sub> controller .....	102
5.6.2.8	Setting the V <sub>dc</sub> controller.....	104
5.6.2.9	Setting the load torque monitoring function .....	105
5.6.3	Commissioning advanced functions .....	107
5.6.3.1	Starting the motor in super torque mode .....	107
5.6.3.2	Starting the motor in hammer start mode .....	109
5.6.3.3	Starting the motor in blockage clearing mode .....	111
5.6.3.4	Running the inverter in economy mode .....	113
5.6.3.5	Setting the UL508C-compliant motor overtemperature protection .....	114
5.6.3.6	Setting the free function blocks (FFBs).....	115
5.6.3.7	Setting the flying start function.....	116
5.6.3.8	Setting the automatic restart function .....	117
5.6.3.9	Running the inverter in frost protection mode.....	118
5.6.3.10	Running the inverter in condensation protection mode .....	119
5.6.3.11	Running the inverter in sleep mode .....	120
5.6.3.12	Setting the wobble generator .....	121
5.6.3.13	Running the inverter in motor staging mode.....	122
5.6.3.14	Running the inverter in cavitation protection mode.....	125
5.6.3.15	Setting the user default parameter set.....	126
5.6.3.16	Setting the dual ramp function .....	127
5.6.3.17	Setting the DC coupling function.....	128
5.6.3.18	Setting high/low overload (HO/LO) mode .....	131
5.7	Restoring to defaults .....	132
<b>6</b>	<b>Communicating with the PLC .....</b>	<b>133</b>
6.1	USS communication .....	133
6.2	MODBUS communication .....	138
<b>7</b>	<b>Parameter list .....</b>	<b>147</b>
7.1	Introduction to parameters .....	147
7.2	Parameter list.....	151
<b>8</b>	<b>Faults and alarms .....</b>	<b>281</b>
8.1	Faults .....	281

---

8.2	Alarms .....	289
<b>A</b>	<b>Technical specifications .....</b>	<b>293</b>
<b>B</b>	<b>Options and spare parts .....</b>	<b>301</b>
B.1	Options.....	301
B.1.1	Parameter Loader .....	301
B.1.2	External BOP and BOP Interface Module.....	305
B.1.3	Connecting cable (external BOP to BOP Interface Module) .....	311
B.1.4	Dynamic braking module .....	312
B.1.5	Braking resistor .....	316
B.1.6	Line reactor .....	320
B.1.7	Output reactor .....	326
B.1.8	External EMC filter class B .....	330
B.1.9	Shield connection kits .....	333
B.1.10	Memory card .....	336
B.1.11	RS485 termination resistor .....	336
B.1.12	DIN rail mounting kits .....	336
B.1.13	User documentation .....	337
B.2	Spare parts - replacement fans .....	337
	<b>Index.....</b>	<b>341</b>



## Safety instructions

### 1.1 Fundamental safety instructions

#### 1.1.1 General safety instructions



<b>! DANGER</b>	
<p><b>Danger to life due to live parts and other energy sources</b></p> <p>Death or serious injury can result when live parts are touched.</p> <ul style="list-style-type: none"> <li>• Only work on electrical devices when you are qualified for this job.</li> <li>• Always observe the country-specific safety rules.</li> </ul> <p>Generally, six steps apply when establishing safety:</p> <ol style="list-style-type: none"> <li>1. Prepare for shutdown and notify all those who will be affected by the procedure.</li> <li>2. Disconnect the machine from the supply.                             <ul style="list-style-type: none"> <li>– Switch off the machine.</li> <li>– Wait until the discharge time specified on the warning labels has elapsed.</li> <li>– Check that it really is in a no-voltage condition, from phase conductor to phase conductor and phase conductor to protective conductor.</li> <li>– Check whether the existing auxiliary supply circuits are de-energized.</li> <li>– Ensure that the motors cannot move.</li> </ul> </li> <li>3. Identify all other dangerous energy sources, e.g. compressed air, hydraulic systems, or water.</li> <li>4. Isolate or neutralize all hazardous energy sources by closing switches, grounding or short-circuiting or closing valves, for example.</li> <li>5. Secure the energy sources against switching on again.</li> <li>6. Ensure that the correct machine is completely interlocked.</li> </ol> <p>After you have completed the work, restore the operational readiness in the inverse sequence.</p>	<p><b>! DANGER</b></p>



<b>! WARNING</b>	
<p><b>Danger to life through a hazardous voltage when connecting an unsuitable power supply</b></p> <p>Touching live components can result in death or severe injury.</p> <ul style="list-style-type: none"> <li>• Only use power supplies that provide SELV (Safety Extra Low Voltage) or PELV- (Protective Extra Low Voltage) output voltages for all connections and terminals of the electronics modules.</li> </ul>	<p><b>! WARNING</b></p>



**⚠ WARNING**

**Danger to life when live parts are touched on damaged devices**

Improper handling of devices can cause damage.

For damaged devices, hazardous voltages can be present at the enclosure or at exposed components; if touched, this can result in death or severe injury.

- Ensure compliance with the limit values specified in the technical data during transport, storage and operation.
- Do not use any damaged devices.



**⚠ WARNING**

**Danger to life through electric shock due to unconnected cable shields**

Hazardous touch voltages can occur through capacitive cross-coupling due to unconnected cable shields.

- As a minimum, connect cable shields and the conductors of power cables that are not used (e.g. brake cores) at one end at the grounded housing potential.



**⚠ WARNING**

**Danger to life due to electric shock when not grounded**

For missing or incorrectly implemented protective conductor connection for devices with protection class I, high voltages can be present at open, exposed parts, which when touched, can result in death or severe injury.

- Ground the device in compliance with the applicable regulations.



**⚠ WARNING**

**Danger to life due to electric shock when opening plug connections in operation**

When opening plug connections in operation, arcs can result in severe injury or death.

- Only open plug connections when the equipment is in a no-voltage state, unless it has been explicitly stated that they can be opened in operation.

**⚠ WARNING**

**Danger to life due to fire spreading if housing is inadequate**

Fire and smoke development can cause severe personal injury or material damage.

- Install devices without a protective housing in a metal control cabinet (or protect the device by another equivalent measure) in such a way that contact with fire is prevented.
- Ensure that smoke can only escape via controlled and monitored paths.

 **WARNING****Danger to life through unexpected movement of machines when using mobile wireless devices or mobile phones**

Using mobile wireless devices or mobile phones with a transmit power > 1 W closer than approx. 2 m to the components may cause the devices to malfunction, influence the functional safety of machines therefore putting people at risk or causing material damage.

- Switch the wireless devices or mobile phones off in the immediate vicinity of the components.

 **WARNING****Danger to life due to the motor catching fire in the event of insulation overload**

There is higher stress on the motor insulation through a ground fault in an IT system. If the insulation fails, it is possible that death or severe injury can occur as a result of smoke and fire.

- Use a monitoring device that signals an insulation fault.
- Correct the fault as quickly as possible so the motor insulation is not overloaded.

 **WARNING****Danger to life due to fire if overheating occurs because of insufficient ventilation clearances**

Inadequate ventilation clearances can cause overheating of components with subsequent fire and smoke. This can cause severe injury or even death. This can also result in increased downtime and reduced service lives for devices/systems.

- Ensure compliance with the specified minimum clearance as ventilation clearance for the respective component.

 **WARNING****Danger of an accident occurring due to missing or illegible warning labels**

Missing or illegible warning labels can result in accidents involving death or serious injury.

- Check that the warning labels are complete based on the documentation.
- Attach any missing warning labels to the components, in the national language if necessary.
- Replace illegible warning labels.

<b>NOTICE</b>
<b>Device damage caused by incorrect voltage/insulation tests</b>
Incorrect voltage/insulation tests can damage the device.
<ul style="list-style-type: none"><li>• Before carrying out a voltage/insulation check of the system/machine, disconnect the devices as all converters and motors have been subject to a high voltage test by the manufacturer, and therefore it is not necessary to perform an additional test within the system/machine.</li></ul>

 <b>WARNING</b>
<b>Danger to life when safety functions are inactive</b>
Safety functions that are inactive or that have not been adjusted accordingly can cause operational faults on machines that could lead to serious injury or death.
<ul style="list-style-type: none"><li>• Observe the information in the appropriate product documentation before commissioning.</li><li>• Carry out a safety inspection for functions relevant to safety on the entire system, including all safety-related components.</li><li>• Ensure that the safety functions used in your drives and automation tasks are adjusted and activated through appropriate parameterizing.</li><li>• Perform a function test.</li><li>• Only put your plant into live operation once you have guaranteed that the functions relevant to safety are running correctly.</li></ul>

**Note**

**Important safety notices for Safety Integrated functions**

If you want to use Safety Integrated functions, you must observe the safety notices in the Safety Integrated manuals.

 <b>WARNING</b>
<b>Danger to life or malfunctions of the machine as a result of incorrect or changed parameterization</b>
As a result of incorrect or changed parameterization, machines can malfunction, which in turn can lead to injuries or death.
<ul style="list-style-type: none"><li>• Protect the parameterization (parameter assignments) against unauthorized access.</li><li>• Respond to possible malfunctions by applying suitable measures (e.g. EMERGENCY STOP or EMERGENCY OFF).</li></ul>



### 1.1.2 Safety instructions for electromagnetic fields (EMF)



#### WARNING

##### **Danger to life from electromagnetic fields**

Electromagnetic fields (EMF) are generated by the operation of electrical power equipment such as transformers, converters or motors.

People with pacemakers or implants are at a special risk in the immediate vicinity of these devices/systems.

- Ensure that the persons involved are the necessary distance away (minimum 2 m).

### 1.1.3 Handling electrostatic sensitive devices (ESD)

Electrostatic sensitive devices (ESD) are individual components, integrated circuits, modules or devices that may be damaged by either electric fields or electrostatic discharge.



#### NOTICE

##### **Damage through electric fields or electrostatic discharge**

Electric fields or electrostatic discharge can cause malfunctions through damaged individual components, integrated circuits, modules or devices.

- Only pack, store, transport and send electronic components, modules or devices in their original packaging or in other suitable materials, e.g. conductive foam rubber or aluminum foil.
- Only touch components, modules and devices when you are grounded by one of the following methods:
  - Wearing an ESD wrist strap
  - Wearing ESD shoes or ESD grounding straps in ESD areas with conductive flooring
- Only place electronic components, modules or devices on conductive surfaces (table with ESD surface, conductive ESD foam, ESD packaging, ESD transport container).

## 1.1.4 Industrial security

### Note

#### Industrial security

Siemens provides products and solutions with industrial security functions that support the secure operation of plants, solutions, machines, equipment and/or networks. They are important components in a holistic industrial security concept. With this in mind, Siemens' products and solutions undergo continuous development. Siemens recommends strongly that you regularly check for product updates.

For the secure operation of Siemens products and solutions, it is necessary to take suitable preventive action (e.g. cell protection concept) and integrate each component into a holistic, state-of-the-art industrial security concept. Third-party products that may be in use should also be considered. For more information about industrial security, visit Hotspot text (<http://www.siemens.com/industrialsecurity>).

To stay informed about product updates as they occur, sign up for a product-specific newsletter. For more information, visit Hotspot text (<http://support.automation.siemens.com>).

### WARNING

#### Danger as a result of unsafe operating states resulting from software manipulation

Software manipulation (e.g. by viruses, Trojan horses, malware, worms) can cause unsafe operating states to develop in your installation which can result in death, severe injuries and/or material damage.

- Keep the software up to date.  
You will find relevant information and newsletters at this address (<http://support.automation.siemens.com>).
- Incorporate the automation and drive components into a holistic, state-of-the-art industrial security concept for the installation or machine.  
You will find further information at this address (<http://www.siemens.com/industrialsecurity>).
- Make sure that you include all installed products into the holistic industrial security concept.

### 1.1.5 Residual risks of power drive systems

The control and drive components of a drive system are approved for industrial and commercial use in industrial line supplies. Their use in public line supplies requires a different configuration and/or additional measures.

These components may only be operated in closed housings or in higher-level control cabinets with protective covers that are closed, and when all of the protective devices are used.

These components may only be handled by qualified and trained technical personnel who are knowledgeable and observe all of the safety instructions on the components and in the associated technical user documentation.

When assessing the machine's risk in accordance with the respective local regulations (e.g., EC Machinery Directive), the machine manufacturer must take into account the following residual risks emanating from the control and drive components of a drive system:

1. Unintentional movements of driven machine components during commissioning, operation, maintenance, and repairs caused by, for example,
  - Hardware and/or software errors in the sensors, control system, actuators, and cables and connections
  - Response times of the control system and of the drive
  - Operation and/or environmental conditions outside the specification
  - Condensation/conductive contamination
  - Parameterization, programming, cabling, and installation errors
  - Use of wireless devices/mobile phones in the immediate vicinity of the control system
  - External influences/damage
2. In the event of a fault, exceptionally high temperatures, including an open fire, as well as emissions of light, noise, particles, gases, etc. can occur inside and outside the inverter, e.g.:
  - Component failure
  - Software errors
  - Operation and/or environmental conditions outside the specification
  - External influences/damage

Inverters of the Open Type/IP20 degree of protection must be installed in a metal control cabinet (or protected by another equivalent measure) such that contact with fire inside and outside the inverter is not possible.
3. Hazardous shock voltages caused by, for example,
  - Component failure
  - Influence during electrostatic charging
  - Induction of voltages in moving motors
  - Operation and/or environmental conditions outside the specification
  - Condensation/conductive contamination
  - External influences/damage

*1.1 Fundamental safety instructions*

4. Electrical, magnetic and electromagnetic fields generated in operation that can pose a risk to people with a pacemaker, implants or metal replacement joints, etc., if they are too close
5. Release of environmental pollutants or emissions as a result of improper operation of the system and/or failure to dispose of components safely and correctly

---

**Note**

The components must be protected against conductive contamination (e.g. by installing them in a control cabinet with degree of protection IP54 according to IEC 60529 or NEMA 12).

Assuming that conductive contamination at the installation site can definitely be excluded, a lower degree of cabinet protection may be permitted.

---

For more information about residual risks of the components in a drive system, see the relevant sections in the technical user documentation.

## 1.2 Additional safety instructions

### General



#### **! DANGER**

##### **Protective earthing conductor current**

The earth leakage current of the SINAMICS V20 inverter may exceed 3.5 mA AC. Due to this, a fixed earth connection is required and the minimum size of the protective earth conductor shall comply with the local safety regulations for high leakage current equipment.

The SINAMICS V20 inverter has been designed to be protected by fuses; however, as the inverter can cause a DC current in the protective earthing conductor, if a Residual Current Device (RCD) is to be used upstream in the supply, observe the following:

- All SINAMICS V20 single phase AC 230 V inverters (filtered or unfiltered) can be operated on a type A<sup>1)</sup> 30 mA or type B(k) 30 mA RCD.
- All SINAMICS V20 three phase AC 400 V inverters (unfiltered) can be operated on a type B(k) 30 mA RCD.
- SINAMICS V20 three phase AC 400 V inverters (filtered) with rated power up to 2.2 kW can be operated on a type B(k) 30 mA RCD. For inverters with rated power over 3.0 kW, a type B(k) 300 mA RCD can be used.

<sup>1)</sup> To use a type A RCD, the regulations in this FAQ must be followed: Siemens Web site (<http://support.automation.siemens.com/WW/view/en/49232264>)



#### **! WARNING**

##### **Safe use of inverters**

Any unauthorized modifications of the equipment are not allowed.

Protection in case of direct contact by means of voltages < 60 V (PELV = Protective Extra Low Voltage according to EN 61800-5-1) is only permissible in areas with equipotential bonding and in dry indoor rooms. If these conditions are not fulfilled, other protective measures against electric shock must be applied, for example, protective insulation.

Install the inverter on a metal mounting plate in a control cabinet. The mounting plate has to be unpainted and with a good electrical conductivity.

It is strictly prohibited for any mains disconnection to be performed on the motor-side of the system, if the inverter is in operation and the output current is not zero.

## Installation

### **WARNING**

#### **Requirements for United States / Canadian installations (UL/cUL)**

Suitable for use on a circuit capable of delivering not more than 40000 rms Symmetrical Amperes, 480 Vac maximum for 400 V variants of inverters or 240 Vac maximum for 230 V variants of inverters, when protected by UL/cUL-certified Class J fuses or type E combination motor controllers. For each frame size A to E, use 75 °C copper wire only.

This equipment is capable of providing internal motor overload protection according to UL508C. In order to comply with UL508C, parameter P0610 must not be changed from its factory setting of 6.

For Canadian (cUL) installations the inverter mains supply must be fitted with any external recommended suppressor with the following features:

- Surge-protective devices; device shall be a Listed Surge-protective device (Category code VZCA and VZCA7)
- Rated nominal voltage 480/277 VAC (for 400 V variants) or 240 VAC (for 230 V variants), 50/60 Hz, three phase (for 400 V variants) or single phase (for 230V variants)
- Clamping voltage VPR = 2000 V (for 400 V variants) / 1000 V (for 230 V variants), IN = 3 kA min, MCOV = 508 VAC (for 400 V variants) / 264 VAC (for 230V variants), SCCR = 40 kA
- Suitable for Type 1 or Type 2 SPD application
- Clamping shall be provided between phases and also between phase and ground

### **WARNING**

#### **Branch-circuit protective device**

The opening of the branch-circuit protective device may be an indication that a fault current has been interrupted. To reduce the risk of fire or electric shock, current-carrying parts and other components of the controller should be examined and the controller should be replaced if damaged. If burnout of the current element of an overload relay occurs, the complete overload relay must be replaced.

Integral solid state short circuit protection does not provide branch circuit protection. Branch circuit protection must be provided in accordance with the National Electrical Code and any additional local codes.

### **CAUTION**

#### **Cable connection**

Separate the control cables from the power cables as much as possible.

Keep the connecting cables away from rotating mechanical parts.

**NOTICE****Motor supply voltage**

Make sure that the motor is configured for the correct supply voltage.

**Inverter mounting**

Mount the inverter vertically to a flat and non-combustible surface.

**Operation** **WARNING****Use of braking resistor**

If an unsuitable braking resistor is used, this could result in a fire and severe damage to people, property and equipment. Use an appropriate braking resistor and install it correctly.

The temperature of a braking resistor increases significantly during operation. Avoid coming into direct contact with braking resistors.

 **WARNING****Hot surface**

During operation and for a short time after switching-off the inverter, the marked surfaces of the inverter can reach a high temperature. Avoid coming into direct contact with these surfaces.

 **CAUTION****Use of fuses**

This equipment is suitable for use in a power system up to 40,000 symmetrical amperes (rms), for the maximum rated voltage + 10 % when protected by an appropriate standard fuse.

**Repair** **WARNING****Repair and replacement of equipment**

Repairs on equipment may only be carried out by Siemens Service, by repair centers authorized by Siemens or by authorized personnel who are thoroughly acquainted with all the warnings and operating procedures contained in this manual.

Any defective parts or components must be replaced using parts contained in the relevant spare parts lists.

Disconnect the power supply before opening the equipment for access.

## **Dismantling and disposal**

<b>NOTICE</b>
<b>Inverter disposal</b> The packaging of the inverter is re-usable. Retain the packaging for future use. Easy-to-release screw and snap connectors allow you to break the unit down into its component parts. You can recycle these component parts, dispose of them in accordance with local requirements or return them to the manufacturer.



## Introduction

### 2.1 Components of the inverter system

The SINAMICS V20 is a range of inverters designed for controlling the speed of three phase asynchronous motors.

#### Three phase AC 400 V variants

The three phase AC 400 V inverters are available in five frame sizes.

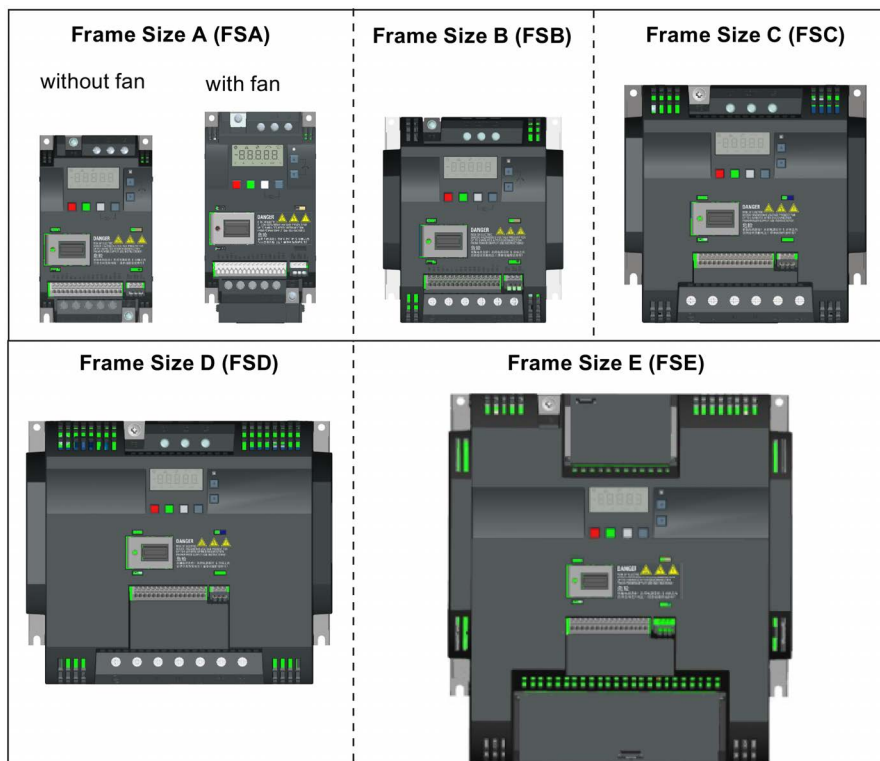

Component	Rated output power	Rated input current	Rated output current	Output current at 480 V at 4kHz/40°C	Order number	
					unfiltered	filtered
Frame size A (without fan)	0.37 kW	1.7 A	1.3 A	1.3 A	6SL3210-5BE13-7UV0	6SL3210-5BE13-7CV0
	0.55 kW	2.1 A	1.7 A	1.6 A	6SL3210-5BE15-5UV0	6SL3210-5BE15-5CV0
	0.75 kW	2.6 A	2.2 A	2.2 A	6SL3210-5BE17-5UV0	6SL3210-5BE17-5CV0
	0.75 kW <sup>1)</sup>	2.6 A	2.2 A	2.2 A	-	6SL3216-5BE17-5CV0
Frame size A (with single fan)	1.1 kW	4.0 A	3.1 A	3.1 A	6SL3210-5BE21-1UV0	6SL3210-5BE21-1CV0
	1.5 kW	5.0 A	4.1 A	4.1 A	6SL3210-5BE21-5UV0	6SL3210-5BE21-5CV0
	2.2 kW	6.4 A	5.6 A	4.8 A	6SL3210-5BE22-2UV0	6SL3210-5BE22-2CV0

2.1 Components of the inverter system

Component	Rated output power	Rated input current	Rated output current	Output current at 480 V at 4kHz/40°C	Order number	
					unfiltered	filtered
Frame size B (with single fan)	3.0 kW	8.6 A	7.3 A	7.3 A	6SL3210-5BE23-0UV0	6SL3210-5BE23-0CV0
	4.0 kW	11.3 A	8.8 A	8.24 A	6SL3210-5BE24-0UV0	6SL3210-5BE24-0CV0
Frame size C (with single fan)	5.5 kW	15.2 A	12.5 A	11 A	6SL3210-5BE25-5UV0	6SL3210-5BE25-5CV0
Frame size D (with two fans)	7.5 kW	20.7 A	16.5 A	16.5 A	6SL3210-5BE27-5UV0	6SL3210-5BE27-5CV0
	11 kW	30.4 A	25 A	21 A	6SL3210-5BE31-1UV0	6SL3210-5BE31-1CV0
	15 kW	38.1 A	31 A	31 A	6SL3210-5BE31-5UV0	6SL3210-5BE31-5CV0
Frame size E (with two fans)	18.5 kW (HO) <sup>2)</sup>	45 A	38 A	34 A	6SL3210-5BE31-8UV0	6SL3210-5BE31-8CV0
	22 kW (LO)	54 A	45 A	40 A		
	22 kW (HO)	54 A	45 A	40 A	6SL3210-5BE32-2UV0	6SL3210-5BE32-2CV0
	30 kW (LO)	72 A	60 A	52 A		

- 1) This variant refers to the Flat Plate inverter with a flat plate heatsink.
- 2) "HO" and "LO" indicate high overload and low overload respectively. You can set the HO/LO mode through relevant parameter settings.

Single phase AC 230 V variants

The single phase AC 230 V inverters are available in three frame sizes.

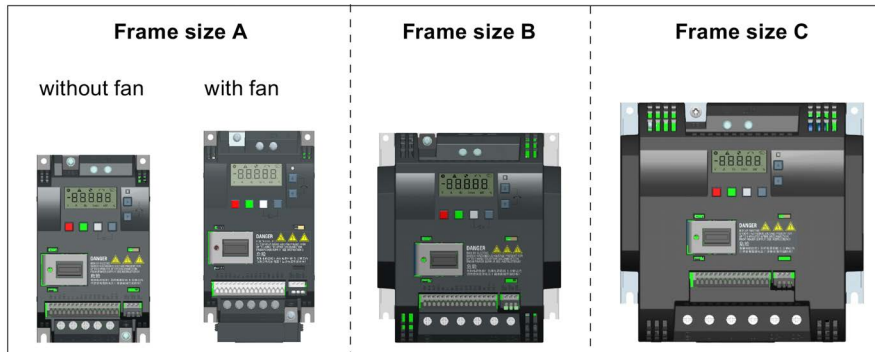

Component	Rated output power	Rated input current	Rated output current	Order number	
				unfiltered	filtered
Frame size A (without fan)	0.12 kW	2.3 A	0.9 A	6SL3210-5BB11-2UV0	6SL3210-5BB11-2AV0
	0.25 kW	4.5 A	1.7 A	6SL3210-5BB12-5UV0	6SL3210-5BB12-5AV0
	0.37 kW	6.2 A	2.3 A	6SL3210-5BB13-7UV0	6SL3210-5BB13-7AV0
	0.55 kW	7.7 A	3.2 A	6SL3210-5BB15-5UV0	6SL3210-5BB15-5AV0
	0.75 kW	10 A	3.9 A	6SL3210-5BB17-5UV0	6SL3210-5BB17-5AV0
Frame size A (with single fan)	0.75 kW	10 A	4.2 A	6SL3210-5BB18-0UV0	6SL3210-5BB18-0AV0
Frame size B (with single fan)	1.1 kW	14.7 A	6.0 A	6SL3210-5BB21-1UV0	6SL3210-5BB21-1AV0
	1.5 kW	19.7 A	7.8 A	6SL3210-5BB21-5UV0	6SL3210-5BB21-5AV0

Component	Rated output power	Rated input current	Rated output current	Order number	
				unfiltered	filtered
Frame size C	2.2 kW	27.2 A	11 A	6SL3210-5BB22-2UV0	6SL3210-5BB22-2AV0
(with single fan)	3.0 kW	32 A	13.6 A	6SL3210-5BB23-0UV0	6SL3210-5BB23-0AV0

## Options and spare parts

For detailed information of the options and spare parts, refer to Appendices "Options (Page 301)" and "Spare parts - replacement fans (Page 337)".

## 2.2 Inverter rating plate

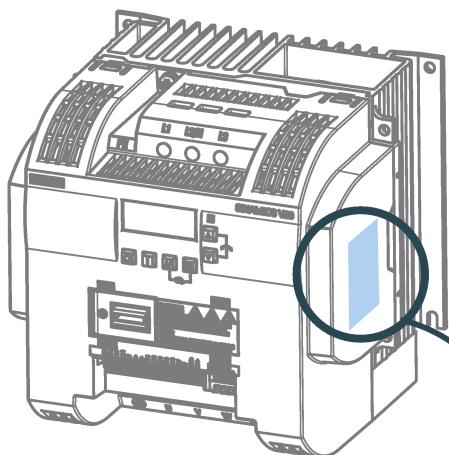

**Inverter rating plate (example)**

**SIEMENS**

SINAMICS V20

INPUT:3Ø AC400-480V +/-10% 10.6A 50/60Hz

OUTPUT:3Ø 0-INPUT V 12.5A 0-550Hz

MOTOR:7.5HP

IND.CONTEQ. LISTED

5B33

INPUT:3Ø AC 380-480V -15%+10% 15.2A 50/60Hz

FS: XX

MOTOR:0.37KW IP20 Filtered Class C3

1P 6SL3210-5BE31-5UV0

S ZVXXXXXXXXXX

SNC-A5E03265837

Order number

Product serial number

Part number

QR code

**EAC**

**CE**

**KCC-REM-S49-SINAMICS**

Refer to user manual

Made in China

Siemens Numerical Control Ltd.

No. 18 Siemens Rd, Jiangning Dev. Zone, Nanjing, 211100, P.R.C



## Mechanical installation

### 3.1 Mounting orientation and clearance

The inverter must be mounted in an enclosed electrical operating area or a control cabinet.

#### Mounting orientation

Always mount the inverter in an upright position.

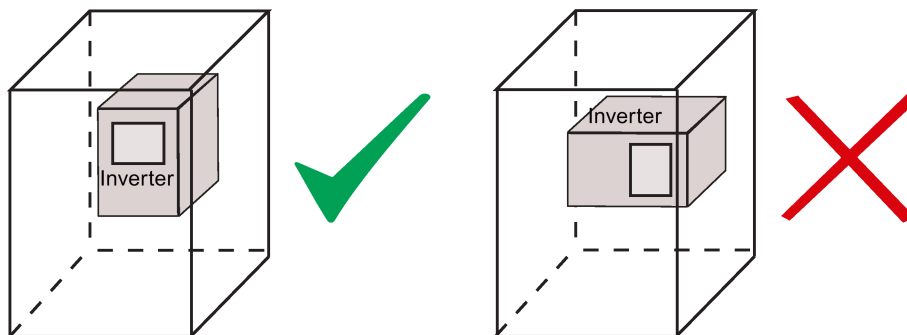

#### Mounting clearance

Top	≥ 100 mm
Bottom	≥ 100 mm (for frame sizes B to E, and frame size A without fan) ≥ 85 mm (for fan-cooled frame size A)
Side	≥ 0 mm

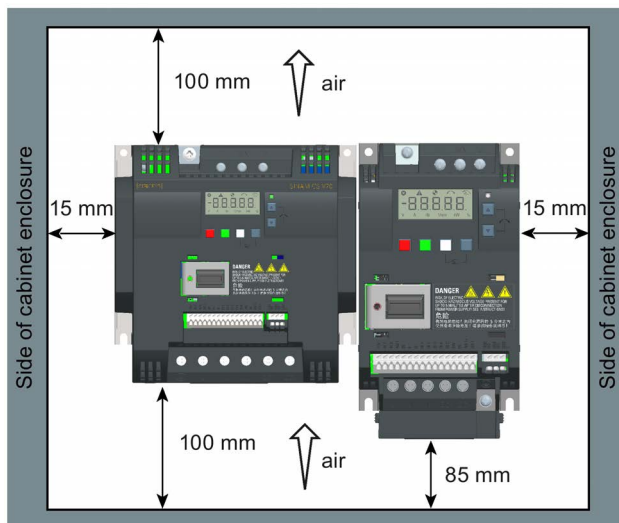

### 3.2 Cabinet panel mounting (frame sizes A to E)

You can mount the inverter directly on the surface of the cabinet panel.

An additional mounting method is also available for different frame sizes. For more details, refer to the following section:

- Push-through mounting (frame sizes B to E) (Page 30)

#### Outline dimensions and drill patterns

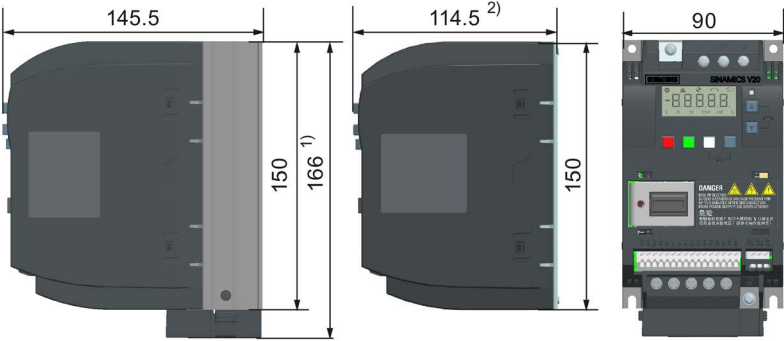
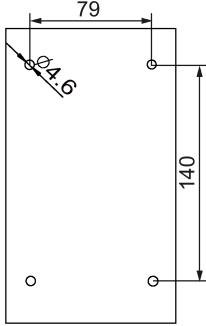
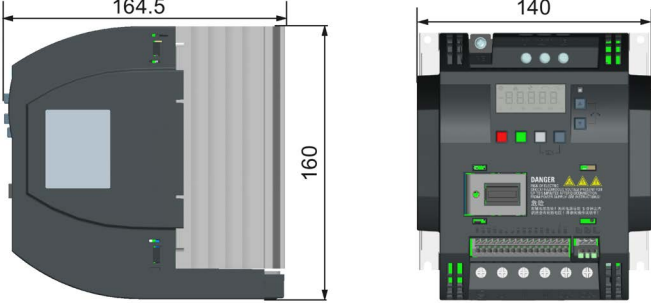
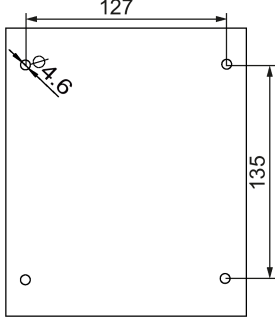
Dimensions (mm)	Drill pattern (mm)
<p>Frame size A</p>  <p>1) Height of frame size A with fan 2) Depth of Flat Plate inverter (400 V 0.75 kW variant only)</p>	 <p>Fixings: 4 x M4 screws, nuts, washers Tightening torque: 1.8 Nm ± 10%</p>
<p>Frame size B</p> 	 <p>Fixings: 4 x M4 screws, nuts, washers Tightening torque: 1.8 Nm ± 10%</p>

3.2 Cabinet panel mounting (frame sizes A to E)

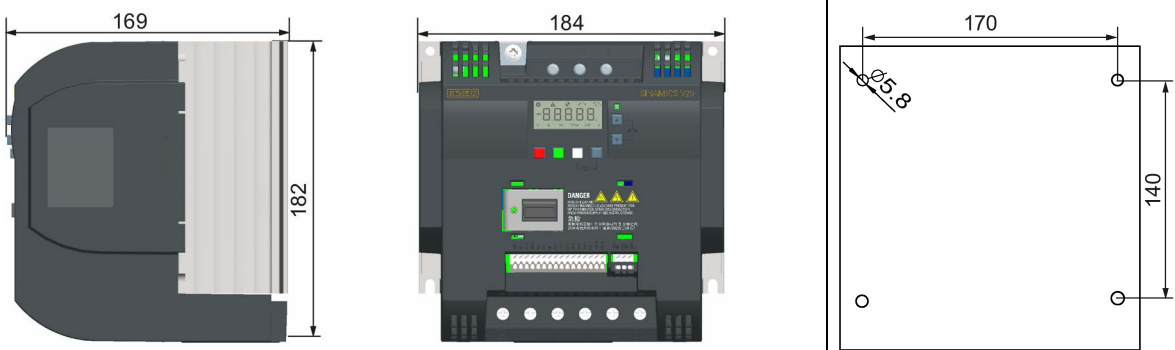
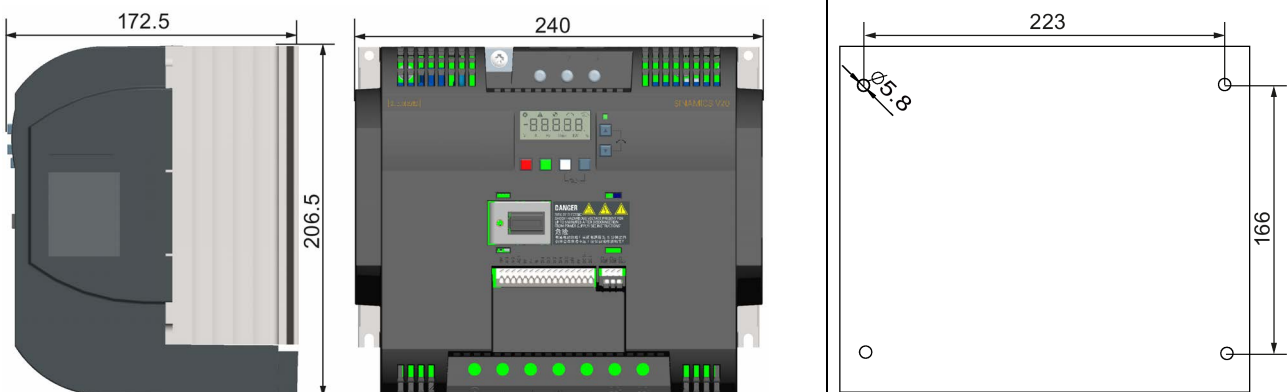
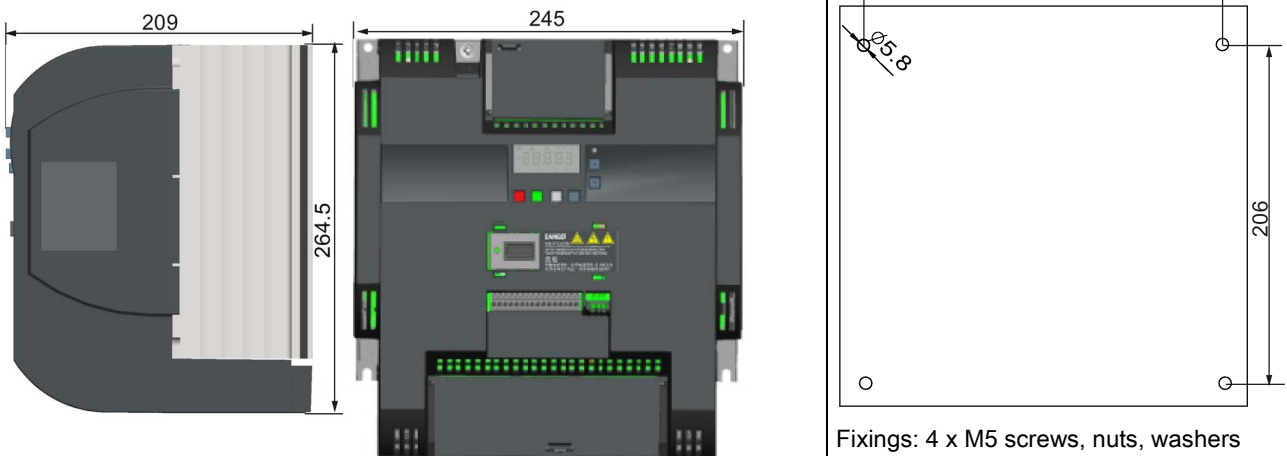
Dimensions (mm)	Drill pattern (mm)
<p>Frame size C</p>  <p>Fixings: 4 x M5 screws, nuts, washers Tightening torque: 2.5 Nm ± 10%</p>	
<p>Frame size D</p>  <p>Fixings: 4 x M5 screws, nuts, washers Tightening torque: 2.5 Nm ± 10%</p>	
<p>Frame size E</p>  <p>Fixings: 4 x M5 screws, nuts, washers Tightening torque: 2.5 Nm ± 10%</p>	

### 3.3 SINAMICS V20 Flat Plate variant

The SINAMICS V20 Flat Plate variant is designed to allow greater flexibility in the installation of the inverter. Adequate measures must be taken to ensure the correct heat dissipation, which may require an additional external heatsink outside the electrical enclosure.



<p><b>⚠ WARNING</b></p> <p><b>Additional heat load</b></p> <p>Operation with an input voltage greater than 400 V and 50 Hz or with a pulse frequency greater than 4 kHz will cause an additional heat load on the inverter. These factors must be taken into account when designing the installation conditions and must be verified by a practical load test.</p>
--

<p><b>⚠ CAUTION</b></p> <p><b>Cooling considerations</b></p> <p>The minimum vertical clearance of 100 mm above and below the inverter must be observed. Stacked mounting is not allowed for the SINAMICS V20 inverters.</p>
---

#### Technical data

Flat Plate variant 6SL3216-5BE17-5CV0	Average power output		
	370 W	550 W	750 W
Operating temperature range	-10 °C to 40 °C		
Max. heatsink loss	24 W	27 W	31 W
Max. control loss *	9.25 W	9.25 W	9.25 W
Recommended thermal resistance of heatsink	1.8 K/W	1.5 K/W	1.2 K/W
Recommended output current	1.3 A	1.7 A	2.2 A

\* With I/O fully loaded



## Installing

1. Prepare the mounting surface for the inverter using the dimensions given in Section "Cabinet panel mounting (frame sizes A to E) (Page 26)".
2. Ensure that any rough edges are removed from the drilled holes, the flat plate heatsink is clean and free from dust and grease, and the mounting surface and if applicable the external heatsink are smooth and made of unpainted metal (steel or aluminium).
3. Apply a non-silicone heat transfer compound with a minimum thermal transfer co-efficient of 0.9 W/m.K evenly to the rear surface of the flat plate heatsink and the surface of the rear plate.
4. Mount the inverter securely using four M4 screws with a tightening torque of 1.8 Nm (tolerance:  $\pm 10\%$ ).
5. If it is required to use an external heatsink, first apply the paste specified in Step 3 evenly to the surface of the external heatsink and the surface of the rear plate, and then connect the external heatsink on the other side of the rear plate.
6. When the installation is completed, run the inverter in the intended application while monitoring r0037[0] (measured heatsink temperature) to verify the cooling effectiveness.

The heatsink temperature must not exceed 90 °C during normal operation, after the allowance has been made for the expected surrounding temperature range for the application.

### **Example:**

If the measurements are made in 20 °C surrounding, and the machine is specified up to 40 °C, then the heatsink temperature reading must be increased by  $[40-20] = 20$  °C, and the result must remain below 90 °C.

If the heatsink temperature exceeds the above limit, then further cooling must be provided (for example, with an extra heatsink) until the conditions are met.

---

### **Note**

The inverter will trip with fault condition F4 if the heatsink temperature rises above 100 °C. This protects the inverter from potential damage due to high temperatures.

---

### 3.4 Push-through mounting (frame sizes B to E)

The frame sizes B to E are designed to be compatible with "push-through" applications, allowing you to mount the heatsink of the inverter through the back of the cabinet panel. When the inverter is mounted as the push-through variant, no higher IP rating is achieved. Make sure that the required IP rating for the enclosure is maintained.

An additional mounting method is also available for different frame sizes. For more details, refer to the following section:

- Cabinet panel mounting (frame sizes A to E) (Page 26)

#### Outline dimensions, drill patterns, and cut-outs

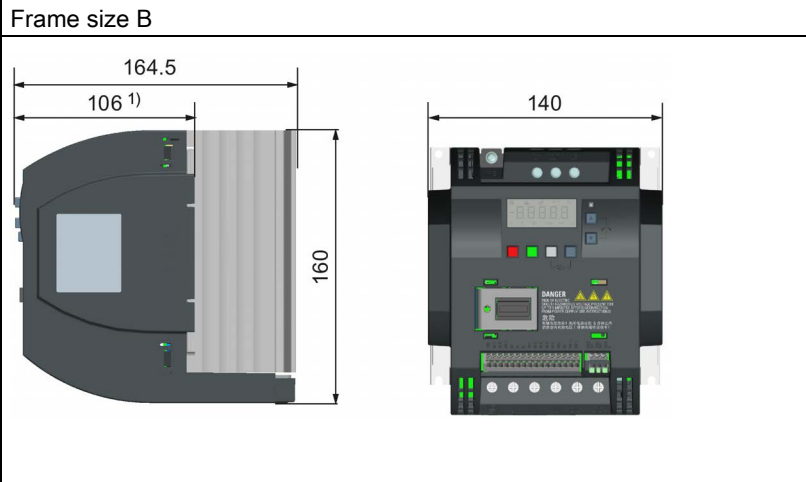
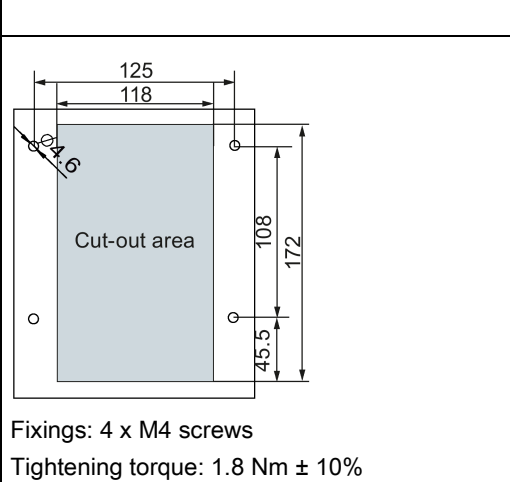
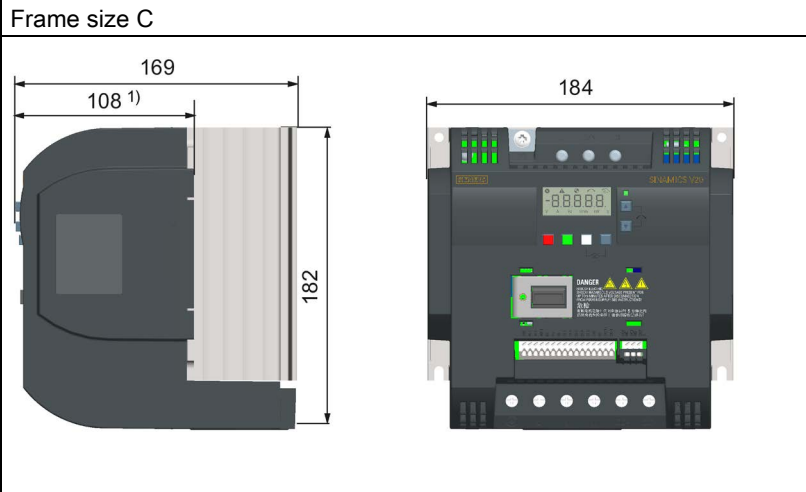
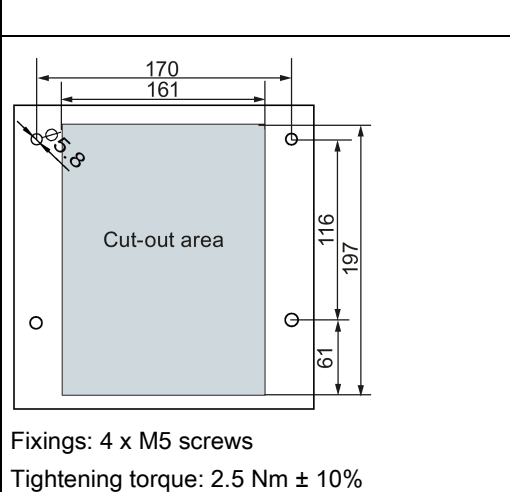
Dimensions (mm)	Drill pattern and cut-out (mm)
<p>Frame size B</p> 	 <p>Fixings: 4 x M4 screws Tightening torque: 1.8 Nm ± 10%</p>
<p>Frame size C</p> 	 <p>Fixings: 4 x M5 screws Tightening torque: 2.5 Nm ± 10%</p>

Dimensions (mm)	Drill pattern and cut-out (mm)
<p>Frame size D</p>	<p>Fixings: 4 x M5 screws Tightening torque: 2.5 Nm ± 10%</p>
<p>Frame size E</p>	<p>Fixings: 4 x M5 screws Tightening torque: 2.5 Nm ± 10%</p>

1) Depth inside the cabinet

### Mounting

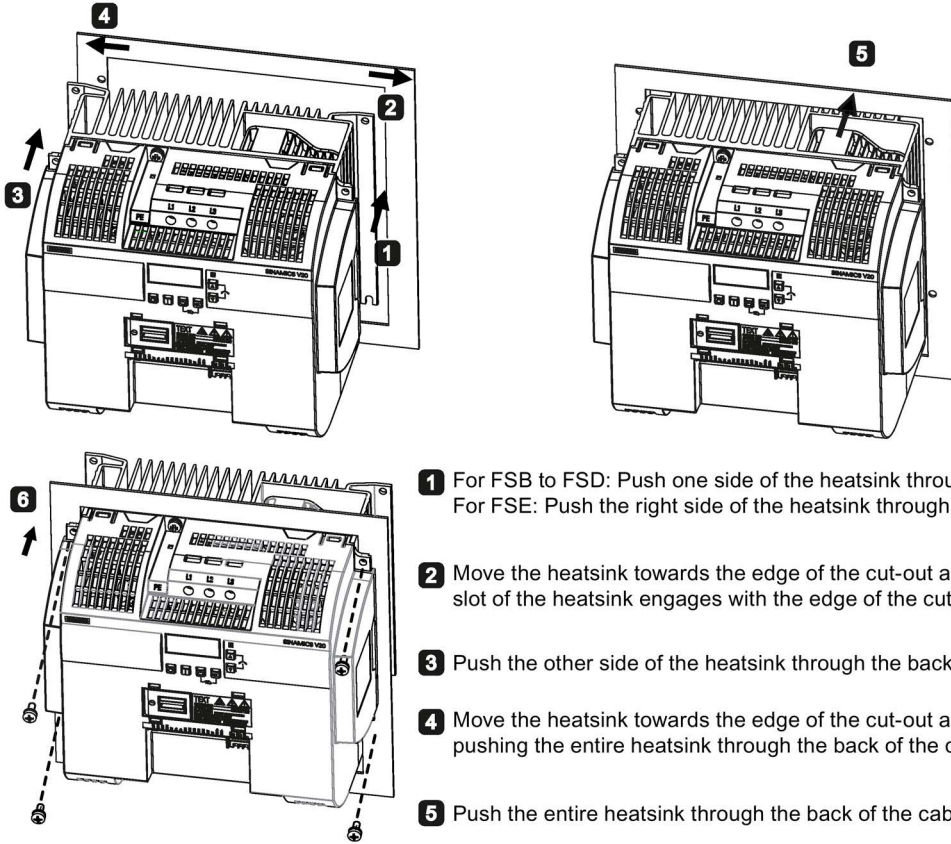

- 1** For FSB to FSD: Push one side of the heatsink through the back of the cabinet panel.  
For FSE: Push the right side of the heatsink through the back of the cabinet panel.
- 2** Move the heatsink towards the edge of the cut-out area until the concaved slot of the heatsink engages with the edge of the cut-out area.
- 3** Push the other side of the heatsink through the back of the cabinet panel.
- 4** Move the heatsink towards the edge of the cut-out area until sufficient space for pushing the entire heatsink through the back of the cabinet panel is left.
- 5** Push the entire heatsink through the back of the cabinet panel.
- 6** Align the four mounting holes in the inverter with the corresponding holes in the cabinet panel. Fix the aligned holes with four screws.

### Note

A gap is reserved at the bottom of the cut-out area to allow fan removal from outside the cabinet without removing the inverter.

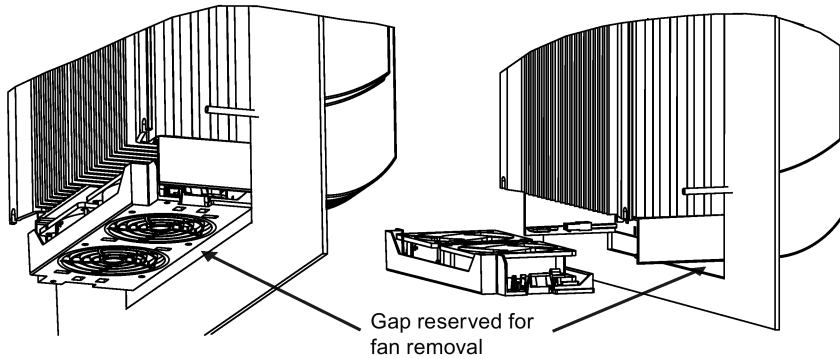

### 3.5 DIN rail mounting (frame sizes A to B)

By means of the optional DIN rail mounting kit, you can mount the frame size A or B on the DIN rail.

Two additional mounting methods are also available for different frame sizes. For more details, refer to the following sections:

- Cabinet panel mounting (frame sizes A to E) (Page 26)
- Push-through mounting (frame sizes B to E) (Page 30)

**Note**

To install or remove FSA/FSB, you can use a crosshead or flat-bit screwdriver.

#### Installing the frame size A to the DIN rail

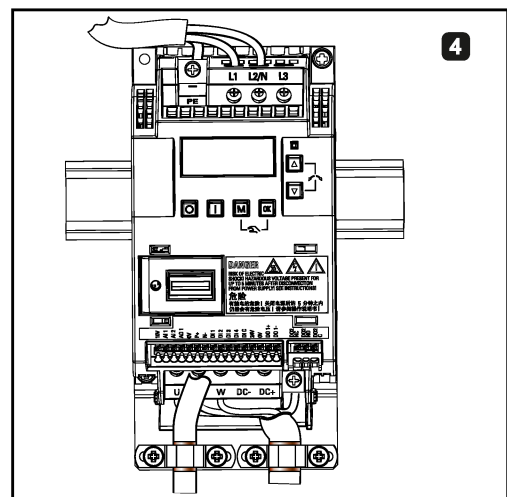
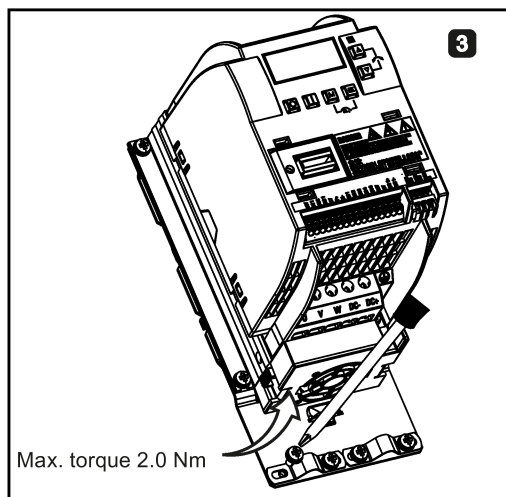
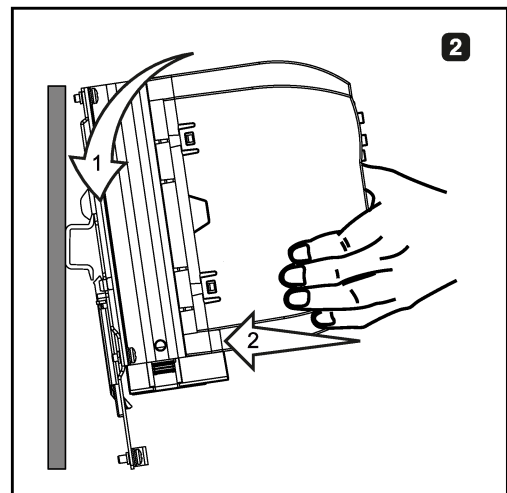
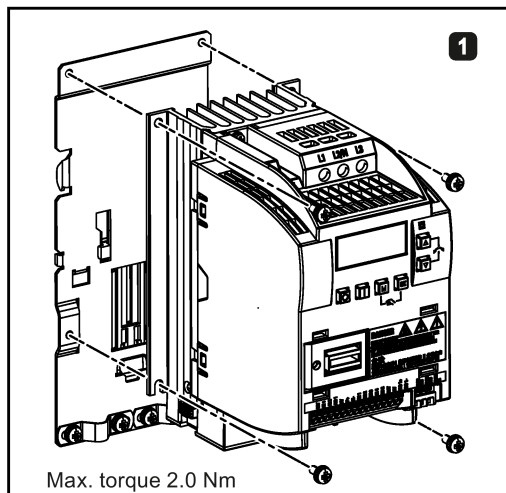

Removing the frame size A from the DIN rail

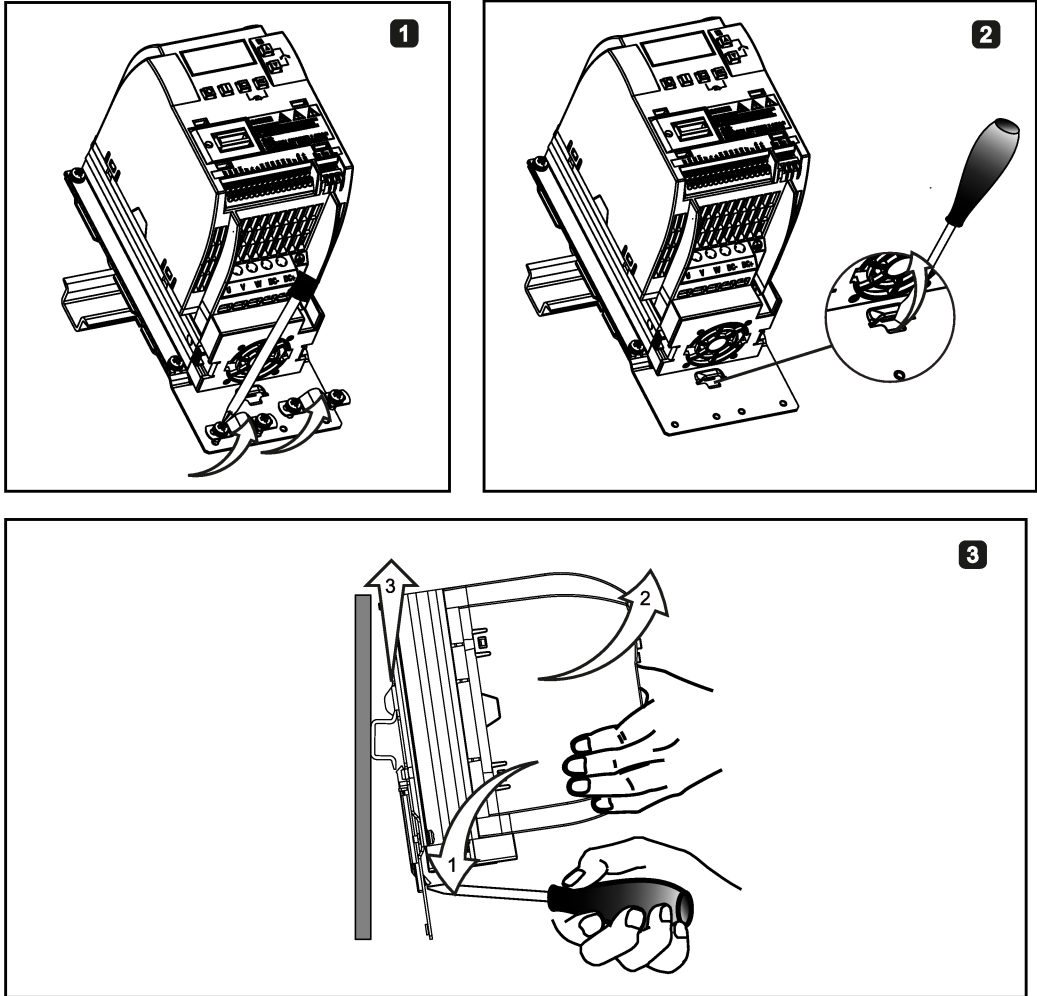

### Installing the frame size B to the DIN rail

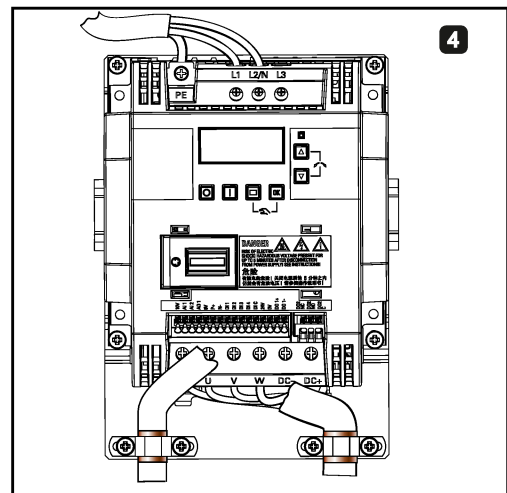
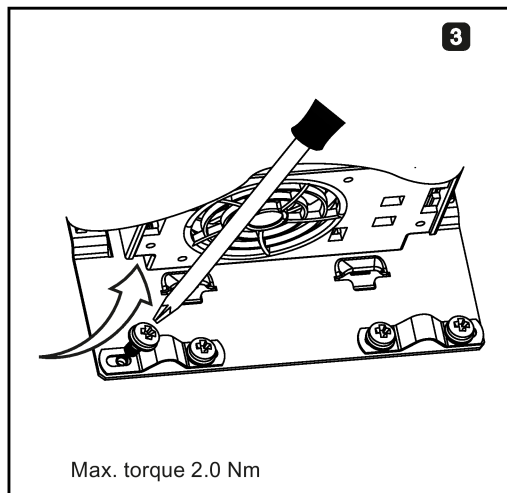
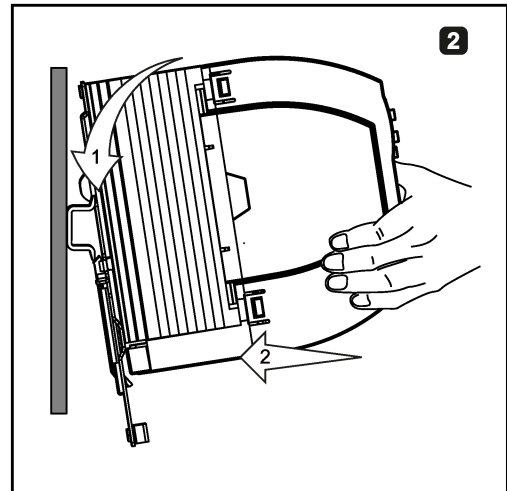
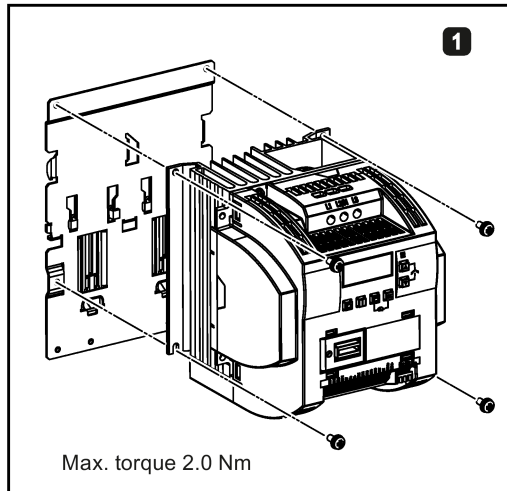

### Removing the frame size B from the DIN rail

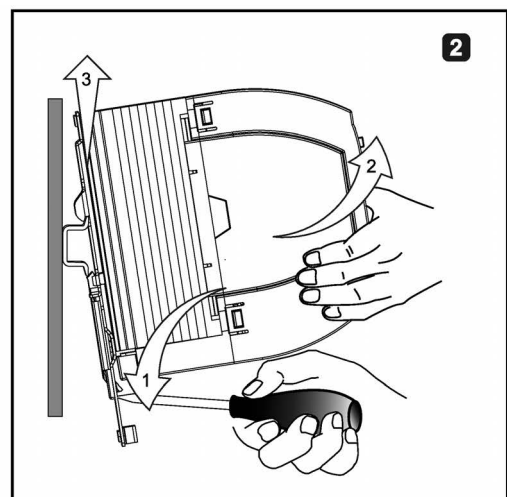
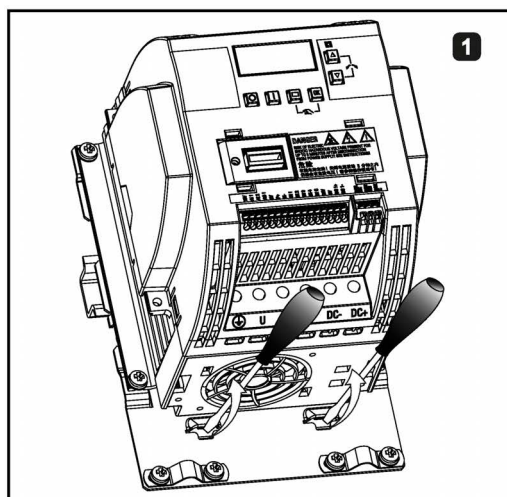





## Electrical installation

### 4.1 Typical system connections

#### Typical system connections

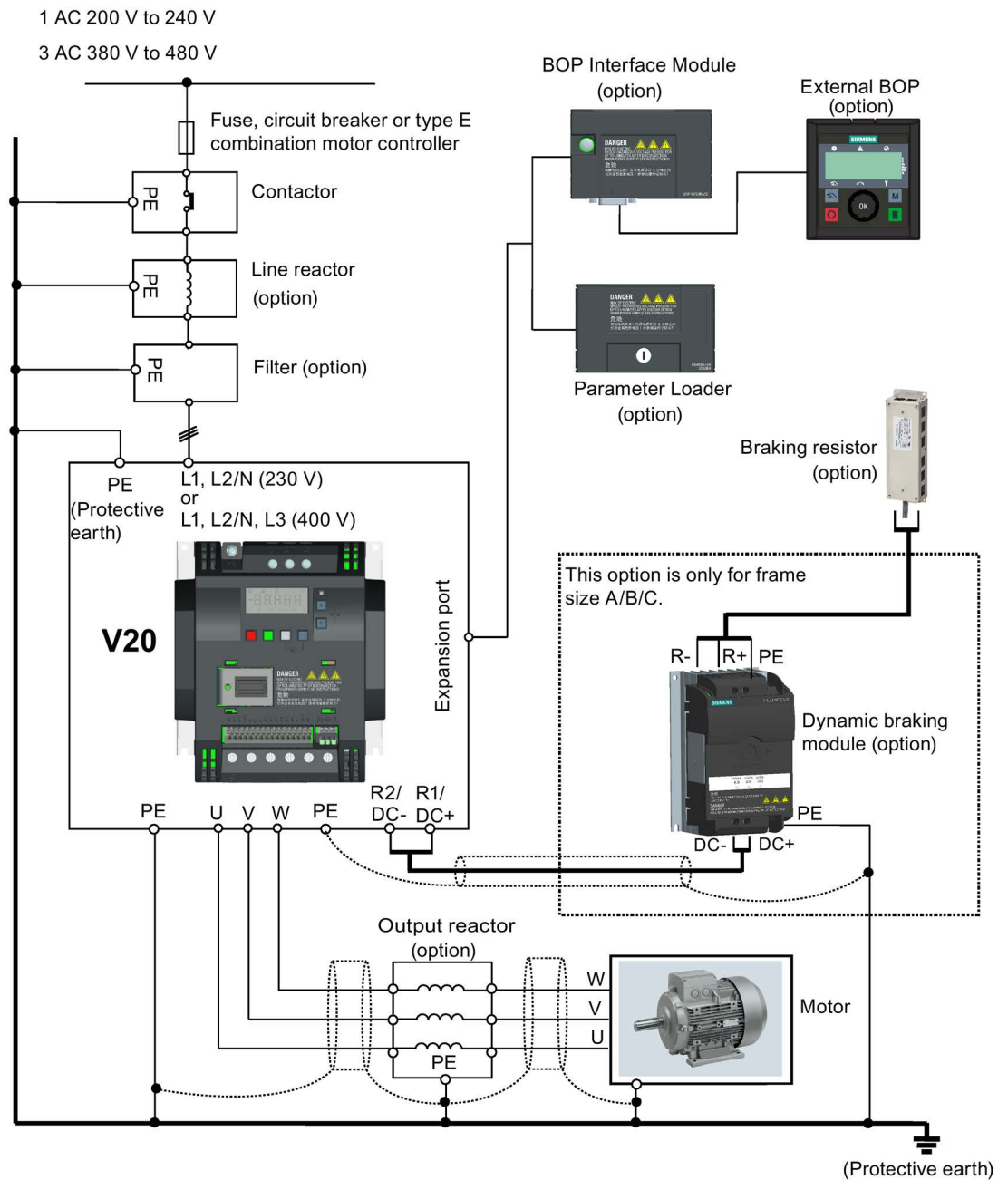

**Recommended fuse types**

Frame size		Recommended fuse type		Frame size	Recommended fuse type			
		CE-compliant (Siemens)	UL/cUL-compliant		CE-compliant (Siemens)	UL/cUL-compliant		
400 V	A	3NA3805 (16 A)	15 A 600 VAC, class J	230 V	A	3NA3805 (16 A)	15 A 600 VAC, class J	
	B	3NA3807 (20 A)	20 A 600 VAC, class J		B	3NA3812 (32 A)	30 A 600 VAC, class J	
	C	3NA3812 (32 A)	30 A 600 VAC, class J		C	3NA3820 (50 A)	50 A 600 VAC, class J	
	D	-	60 A 600 VAC, class J					
	E	18.5 kW	-		70 A 600 VAC, class J			
		22 kW	-		80 A 600 VAC, class J			

**Recommended motor controller types**

Frame size	Inverter power rating (kW)	Type E combination motor controllers				
		Order number (Siemens)	Voltage (V)	Current (A)	Power (hp)	
400 V	A	0.37	3RV20 11-1CA10	480	1.8 to 2.5	1.0
		0.55	3RV20 11-1DA10	480	2.2 to 3.2	1.5
		0.75	3RV20 11-1EA10	480	2.8 to 4.0	2.0
		1.1	3RV20 11-1FA10	480	3.5 to 5.0	3.0
		1.5	3RV20 11-1HA10	480	5.5 to 8.0	5.0
		2.2	3RV20 11-1JA10	480	7.0 to 10.0	5.0
	B	3.0	3RV20 11-1KA10	480	9.0 to 12.5	7.5
		4.0	3RV20 21-4AA10	480	11.0 to 16.0	10.0
	C	5.5	3RV20 21-4BA10	480	14.0 to 20.0	10.0
230 V	A	0.12	3RV20 11-1DA10	230/240	2.2 to 3.2	0.75
		0.25	3RV20 11-1FA10	230/240	3.5 to 5.0	1.0
		0.37	3RV20 11-1HA10	230/240	5.5 to 8.0	2.0
		0.55	3RV20 11-1JA10	230/240	7.0 to 10.0	3.0
		0.75	3RV20 11-1KA10	230/240	9.0 to 12.5	3.0
	B	1.1	3RV20 21-4BA10	230/240	14.0 to 20.0	5.0
		1.5	3RV20 21-4CA10	230/240	17.0 to 22.0	7.5
	C	2.2	3RV20 21-4EA10	230/240	27.0 to 32.0	10.0
		3.0	3RV10 31-4FA10	230/240	28.0 to 40.0	20.0

Wiring diagram

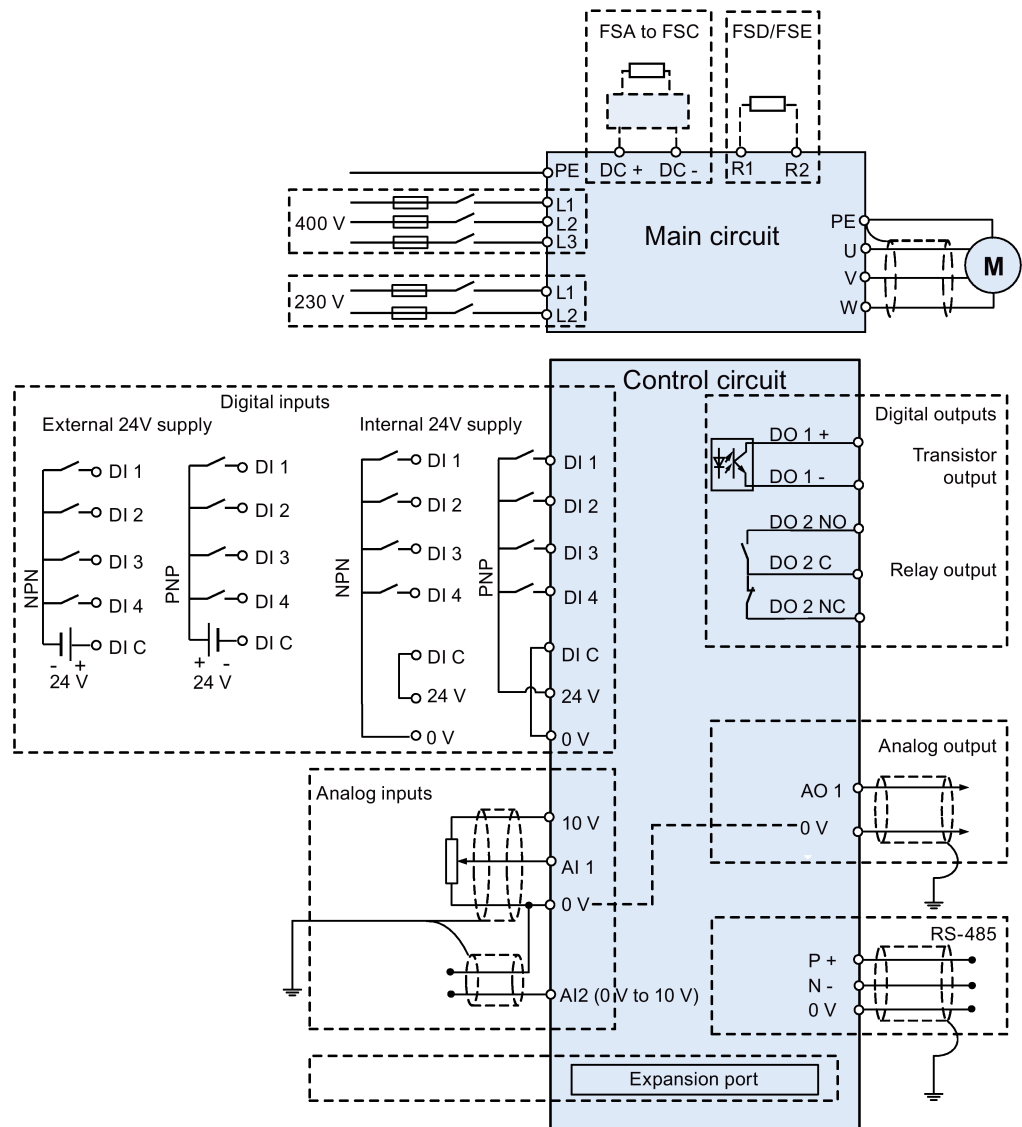

**Note**

The resistance of the potentiometer for each analog input must be  $\geq 4.7 \Omega$ .

See also "Setting connection macros (Page 63)"

## 4.2 Terminal description

### Terminal layout

**Mains terminals**

3AC 400 V	L1 L2/N L3	1AC 230 V	L1 L2/N
FSA to FSD			

**Supported cable types:**

FSA/FSB	FSC/FSD	FSE		Cable with UL/cUL-certified fork crimp
✓	✓	✗		Stranded cable
✓	✓	✗		Cable with pin crimp
✗	✓	✗		Solid cable
✗	✗	✓		Cable with UL/cUL-certified ring crimp

Upper cover (FSE only)

To open the upper cover, push the locking latch of the cover downwards with a flat-bit screwdriver.

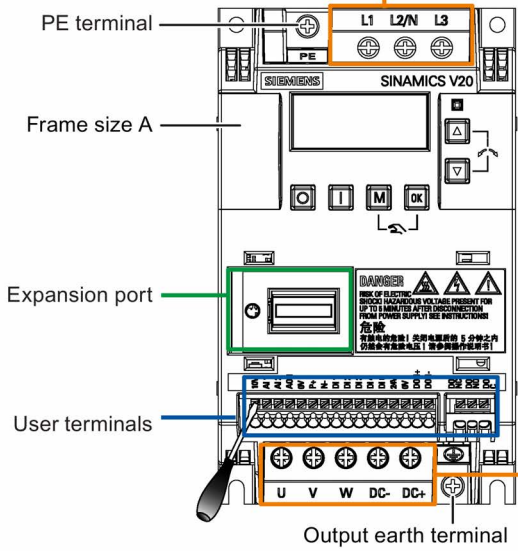

Align a flat-bit screwdriver (bit size: 0.4 x 2.5 mm) with the terminal. Push it downwards on the release lever with a maximum force of 12 N and insert the control wire from below.

**Motor terminals**

FSA			DC terminals
FSB/FSC			
FSD/FSE			Braking resistor terminals (R1, R2)

Ground

Lower cover (FSE only)

To open the lower cover, pull the locking latch of the cover upwards with a flat-bit screwdriver.

User terminals:

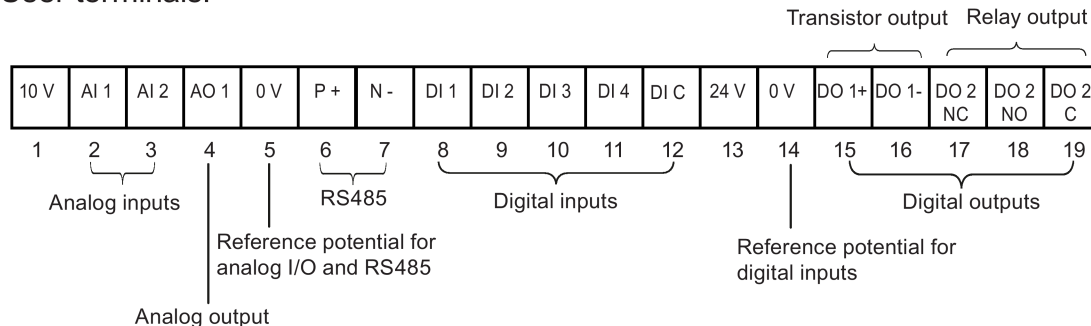

**Note**

To disconnect the built-in EMC filter on FSE, you can use a Pozidriv or flat-bit screwdriver to remove the EMC screw.

**Recommended cable cross-sections and screw tightening torques**

Frame size	Rated output power	Mains and PE terminals		Motor/DC/braking resistor/output earth terminals	
		Cable cross-section*	Screw tightening torque (tolerance: ± 10%)	Cable cross-section*	Screw tightening torque (tolerance: ± 10%)
<b>400 V</b>					
A	0.37 kW to 0.75 kW	1.0 mm <sup>2</sup> (12)	1.0 Nm	1.0 mm <sup>2</sup> (12)	1.0 Nm
	1.1 kW to 2.2 kW	1.5 mm <sup>2</sup> (12)		1.5 mm <sup>2</sup> (12)	
B	3.0 kW to 4.0 kW	6 mm <sup>2</sup> (10)	2.4 Nm	6 mm <sup>2</sup> (10)	1.5 Nm
C	5.5 kW	13.5 mm <sup>2</sup> (6)		8.5 mm <sup>2</sup> (8)	2.4 Nm
	D	7.5 kW		6.0 mm <sup>2</sup> (10)	
		11 kW to 15 kW		10 mm <sup>2</sup> (6)	10 mm <sup>2</sup> (6)
E	18.5 kW (HO)	10 mm <sup>2</sup> (6)		6 mm <sup>2</sup> (8)	
	22 kW (LO)	16 mm <sup>2</sup> (4)		10 mm <sup>2</sup> (6)	
	22 kW (HO)	16 mm <sup>2</sup> (4)		10 mm <sup>2</sup> (6)	
	30 kW (LO)	25 mm <sup>2</sup> (3)		16 mm <sup>2</sup> (4)	
<b>230 V</b>					
A	0.12 kW to 0.25 kW	1.5 mm <sup>2</sup> (12)	1.0 Nm	1.0 mm <sup>2</sup> (12)	1.0 Nm
	0.37 kW to 0.55 kW	2.5 mm <sup>2</sup> (12)			
	0.75 kW	4.0 mm <sup>2</sup> (12)			
B	1.1 kW to 1.5 kW	6.0 mm <sup>2</sup> ** (10)	2.4 Nm	2.5 mm <sup>2</sup> (10)	1.5 Nm
C	2.2 kW to 3.0 kW	10 mm <sup>2</sup> (6)		4.0 mm <sup>2</sup> (8)	2.4 Nm

\* Data in brackets indicate the corresponding AWG values.

\*\* With a UL/cUL-certified, suitable fork crimp

**NOTICE**

**Damage to the mains terminals**

During electrical installation of the inverter frame sizes A and B, only stranded cables or cables with UL/cUL-certified fork crimps can be used for the mains terminal connections; for frame size E, only cables with UL/cUL-certified ring crimps can be used for the mains terminal connections.

**Maximum motor cable lengths**

Inverter variant	Maximum cable length					
	Without output reactor or external EMC filter			With output reactor		With external EMC filter <sup>1)</sup>
<b>400 V</b>	<b>Unshielded</b>	<b>Shielded</b>	<b>EMC compliant (RE/CE C3) <sup>2)</sup></b>	<b>Unshielded</b>	<b>Shielded</b>	<b>EMC compliant (RE/CE C2) <sup>3)</sup></b>
FSA	50 m	25 m	10 m	150 m	150 m	25 m
FSB to FSD	50 m	25 m	25 m	150 m	150 m	25 m
FSE	100 m	50 m	50 m	300 m	200 m	25 m
<b>230 V</b>	<b>Unshielded</b>	<b>Shielded</b>	<b>EMC compliant (RE/CE C2) <sup>2)</sup></b>	<b>Unshielded</b>	<b>Shielded</b>	<b>EMC compliant (RE/CE C2) <sup>3)</sup></b>
FSA	50 m	25 m	10 m	200 m	200 m	5 m
FSB to FSC	50 m	25 m	25 m	200 m	200 m	5 m

- 1) As specified in Section B.1.8.
- 2) For filtered variants only. RE/CE C3 refers to EMC compliance to EN61800-3 Category C3 for Radiated and Conducted Emissions; RE/CE C2 refers to EMC compliance to EN61800-3 Category C2 for Radiated and Conducted Emissions.
- 3) For unfiltered variants only.

**Star-delta connection of the motor**

Select delta connection if either a 230/400 V motor on a 400 V inverter or a 120/230 V motor on a 230 V inverter is supposed to operate at 87 Hz instead of 50 Hz.

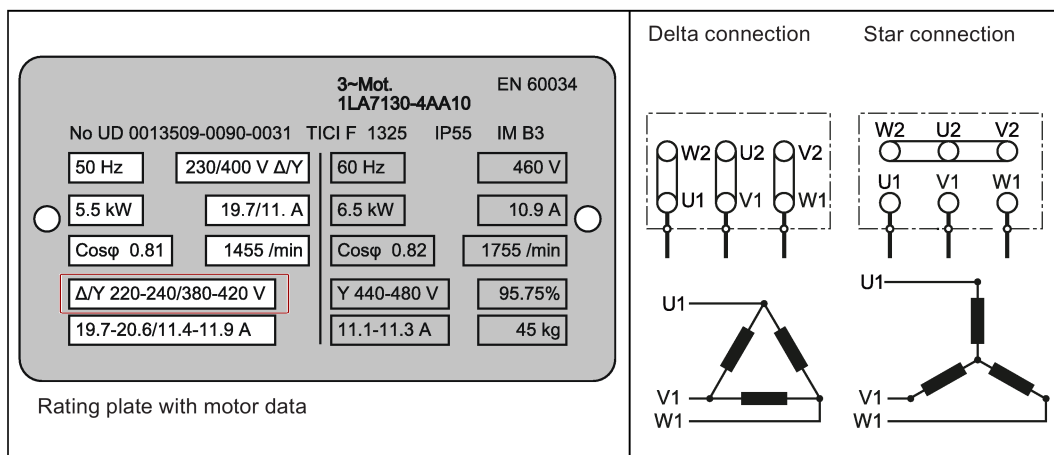

## User terminals

10 V	AI 1	AI 2	AO 1	0 V	P +	N -	DI 1	DI 2	DI 3	DI 4	DI C	24 V	0 V	DO 1+	DO 1-	DO 2 NC	DO 2 NO	DO 2 C
1	2	3	4	5	6	7	8	9	10	11	12	13	14	15	16	17	18	19

	No.	Terminal marking	Description	
	1	10V	10 V output (tolerance $\pm 5\%$ ) referred to 0V, maximum 11 mA, short circuit protected	
<b>Analog inputs</b>	2	AI1	Mode:	AI1: Single-ended, bipolar current and voltage mode
	3	AI2		AI2: Single-ended, unipolar current and voltage mode
			Isolation to control circuit:	None
			Voltage range:	AI1: -10 V to 10 V; AI2: 0 V to 10 V
			Current range:	0 mA to 20 mA (4 mA to 20 mA - software selectable)
			Voltage mode accuracy:	$\pm 5\%$ full scale
			Current mode accuracy:	$\pm 5\%$ full scale
			Input impedance:	Voltage mode: > 30 K Current mode: 235 R
			Resolution:	10-bit
			Wire break detect:	Yes
		Threshold 0 $\Rightarrow$ 1 (used as DIN):	4.0 V	
		Threshold 1 $\Rightarrow$ 0 (used as DIN):	1.6 V	
		Response time (digital input mode):	4 ms $\pm$ 4 ms	
<b>Analog output</b>	4	AO1	Mode:	Single-ended, unipolar current mode
			Isolation to control circuit:	None
			Current range:	0 mA to 20 mA (4 mA to 20 mA - software selectable)
			Accuracy (0 mA to 20 mA):	$\pm 1$ mA
			Output capability:	20 mA into 500 R
	5	0V	Overall reference potential for RS485 communication and analog inputs / output	
	6	P+	RS485 P +	
	7	N-	RS485 N -	
<b>Digital inputs</b>	8	DI1	Mode:	PNP (reference terminal low)
	9	DI2		NPN (reference terminal high)
	10	DI3		Characteristics values are inverted for NPN mode.
	11	DI4	Isolation to control circuit:	500 V DC (functional low voltage)
	12	DI C	Absolute maximum voltage:	$\pm 35$ V for 500 ms every 50 seconds
			Operating voltage:	- 3 V to 30 V
			Threshold 0 $\Rightarrow$ 1 (maximum):	11 V
			Threshold 1 $\Rightarrow$ 0 (minimum):	5 V
			Input current (guaranteed off):	0.6 mA to 2 mA
			Input current (maximum on):	15 mA
		2-wire Bero compatibility:	No	
		Response time:	4 ms $\pm$ 4 ms	

4.2 Terminal description

No.	Terminal marking	Description
		Pulse train input: No
13	24V	24 V output (tolerance: - 15 % to + 20 %) referred to 0 V, maximum 50 mA, non-isolated
14	0V	Overall reference potential for digital inputs
Digital output (transistor)	15 DO1 +	Mode: Normally open voltage-free terminals, polarised
	16 DO1 -	Isolation to control circuit: 500 V DC (functional low voltage)
		Maximum voltage across terminals: ± 35 V
		Maximum load current: 100 mA
		Response time: 4 ms ± 4 ms
Digital output (relay)	17 DO2 NC	Mode: Change-over voltage-free terminals, unpolarised
	18 DO2 NO	Isolation to control circuit: 4 kV (230 V mains)
	19 DO2 C	Maximum voltage across terminals: 240 V AC/30 V DC + 10 %
		Maximum load current: 0.5 A @ 250 V AC, resistive 0.5 A @ 30 V DC, resistive
		Response time: Open: 7 ms ± 7 ms Close: 10 ms ± 9 ms

 <b>WARNING</b>
<b>Risk of electric shock</b>
The input and output terminals, numbered 1 to 16, are safety extra low voltage (SELV) terminals and must only be connected to low voltage supplies.

Permissible I/O terminal cable cross-sections

Cable type	Permissible cable cross-section
Solid or stranded cable	0.5 mm <sup>2</sup> to 1.5 mm <sup>2</sup>
Ferrule with insulating sleeve	0.25 mm <sup>2</sup>

Expansion port

The expansion port is designed for connecting the inverter to the external option module - BOP Interface Module or Parameter Loader, in order to realize the following functions:

- Operating the inverter from the external BOP that is connected to the BOP Interface Module
- Cloning parameters between the inverter and a standard MMC/SD card through the Parameter Loader
- Powering the inverter from the Parameter Loader, when mains power is not available

For more information about these two option modules, refer to the topics "Parameter Loader (Page 301)" and "External BOP and BOP Interface Module (Page 305)".



## 4.3 EMC-compliant installation

### EMC-compliant installation of the inverter

The shield connection kit is supplied as an option for each frame size (For more information about this option, see Appendix "Shield connection kits (Page 333)"). It allows easy and efficient connection of the necessary shield to achieve EMC-compliant installation of the inverter. If no shield connection kit is used, you can alternatively mount the device and additional components on a metal mounting plate with excellent electrical conductivity and a large contact area. This mounting plate must be connected to the cabinet panel and the PE or EMC bus bar.

The following diagram shows an example of EMC-compliant installation of the inverter frame size B/C.

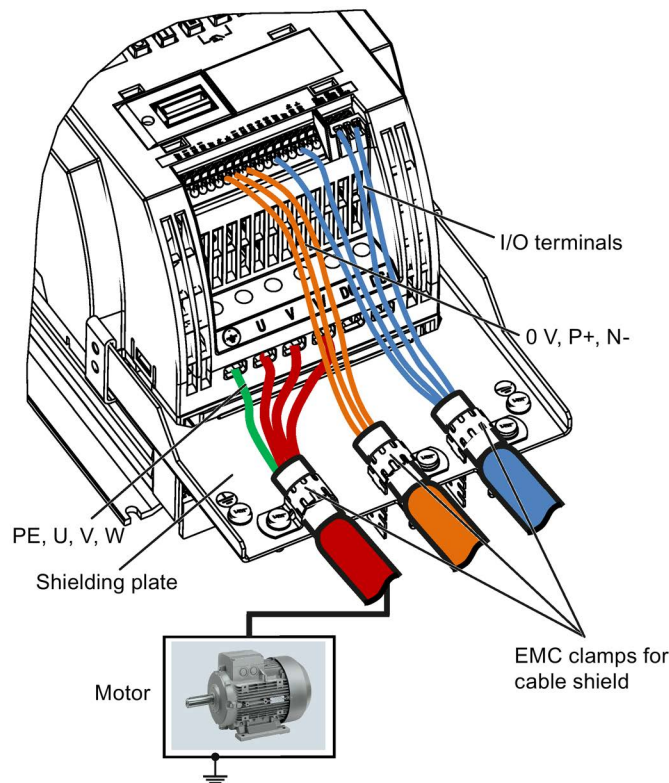

### EMC-compliant installation of external EMC filter options

All 400 V inverters must be mounted in a cabinet with a special EMC gasket around the door.

#### For 400 V unfiltered frame size C inverters fitted with the filters specified in Section B1.8:

To meet the radiated emissions Class A, attach 1 x ferrite of Type "Würth 742-715-4" or equivalent in the vicinity of the inverter mains terminals.

#### For 400 V unfiltered frame size D inverters fitted with the filters specified in Section B1.8:

To meet the radiated emissions Class A, attach 2 x ferrites of Type "Würth 742-715-5" or equivalent in the vicinity of the inverter mains terminals; attach 1x ferrite of Type "Würth 742-712-21" or equivalent in the vicinity of the external EMC filter mains terminals.

#### For 400 V unfiltered frame size E inverters fitted with the filters specified in Section B1.8:

To meet the radiated emissions Class A, attach 1 x ferrite of Type "Seiwa E04SRM563218" or equivalent in the vicinity of the inverter mains terminals; attach 2 x ferrites of Type "Seiwa E04SRM563218" or equivalent in the vicinity of the motor terminals of the inverter.

### Shielding method

The following illustration shows an example with and without the shielding plate.

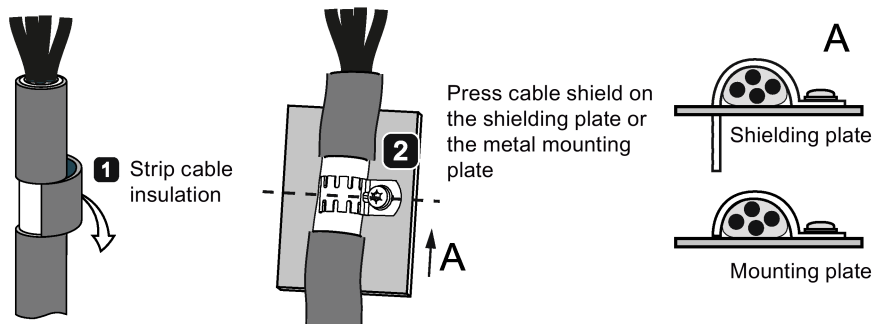

## 4.4 EMC-compliant cabinet design

The most cost-effective method of implementing interference suppression measures within the control cabinet is to ensure that interference sources and potentially susceptible equipment are installed separately from each other.

The control cabinet has to be divided into EMC zones and the devices within the control cabinet have to be assigned to these zones following the rules below.

- The different zones must be electromagnetically decoupled by using separate metallic housings or grounded separation plates.
- If necessary, filters and/or coupling modules should be used at the interfaces of the zones.
- Cables connecting different zones must be separated and must not be routed within the same cable harness or cable channel.
- All communication (e.g. RS485) and signal cables leaving the cabinet must be shielded.

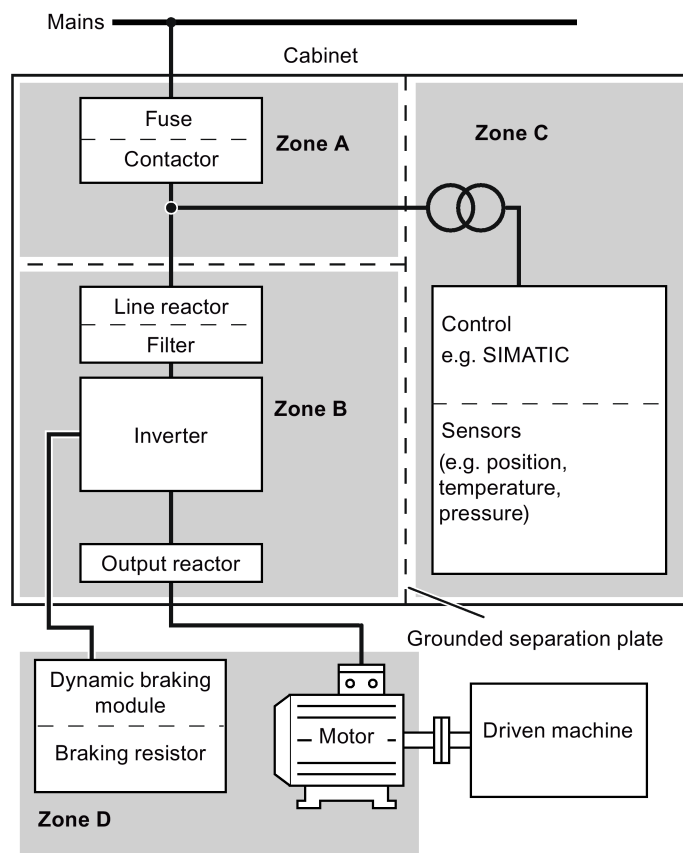



## Commissioning

---

**Note**  
 For a detailed description of parameter settings for the quick commissioning, refer to the topic "Quick commissioning (Page 60)".





---

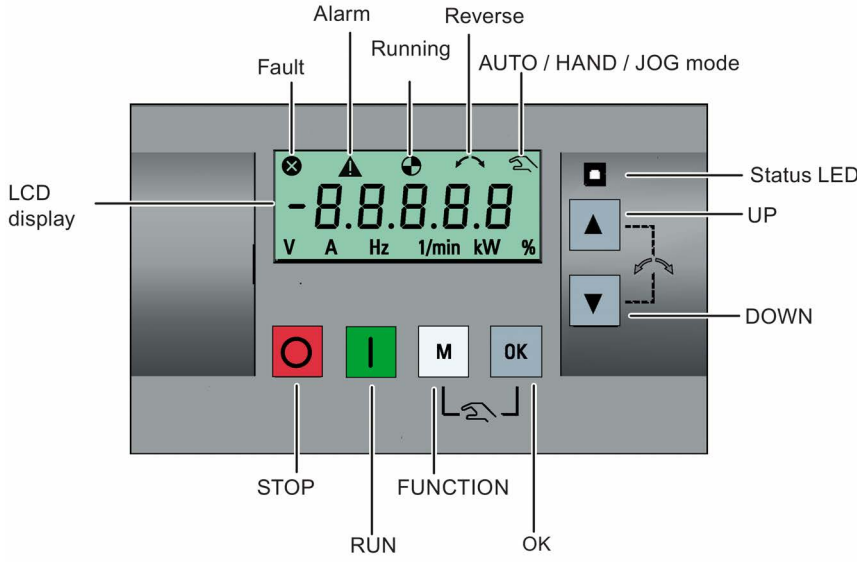



### 5.1 The built-in Basic Operator Panel (BOP)

#### 5.1.1 Introduction to the built-in BOP

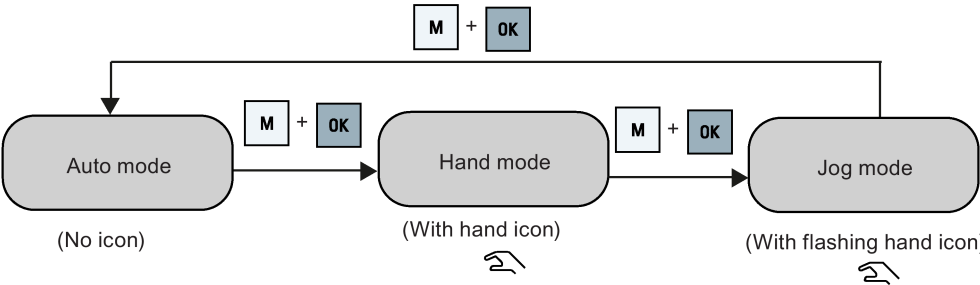

Button functions









	<p><b>Stops the inverter</b></p> <p>Single press</p>	<p>OFF1 stop reaction: the inverter brings the motor to a standstill in the ramp-down time set in parameter P1121.</p> <p><b>Note:</b> If configured to be an OFF1 stop, this button is inactive in AUTO mode.</p>
	<p><b>Starts the inverter</b></p> <p>If the inverter is started in HAND / JOG mode, the inverter running icon (⚙) displays.</p> <p><b>Note:</b> This button is inactive if the inverter is configured for control from terminals (P0700 = 2, P1000 = 2) and is in AUTO mode.</p>	
	<p><b>Multi-function button</b></p> <p>Short press (&lt; 2 s)</p>	<ul style="list-style-type: none"> <li>• Enters the parameter setting menu or moves to the next screen</li> <li>• Restarts the digit by digit editing on the selected item</li> <li>• Returns to the fault code display</li> <li>• If pressed twice in digit by digit editing, returns to the previous screen without changing the item being edited</li> </ul>
	<p>Short press (&lt; 2 s)</p>	<ul style="list-style-type: none"> <li>• Switches between status values</li> <li>• Enters edit value mode or change to the next digit</li> <li>• Clears faults</li> <li>• Returns to the fault code display</li> </ul>
	<p><b>Hand/Jog/Auto</b></p> <p>Press to switch between different modes:</p>	 <pre> graph LR     A[Auto mode (No icon)] -- "M + OK" --&gt; B[Hand mode (With hand icon)]     B -- "M + OK" --&gt; C[Jog mode (With flashing hand icon)]     C -- "M + OK" --&gt; A     </pre> <p><b>Note:</b> Jog mode is only available if the motor is stopped.</p>

	<ul style="list-style-type: none"> <li>When navigating through a menu, it moves the selection up through the screens available.</li> <li>When editing a parameter value, it increases the displayed value.</li> <li>When the inverter is in RUN mode, it increases the speed.</li> <li>Long press (&gt; 2 s) of the key quickly scrolls up through parameter numbers, indices, or values.</li> </ul>
	<ul style="list-style-type: none"> <li>When navigating through a menu, it moves the selection down through the screens available.</li> <li>When editing a parameter value, it decreases the displayed value.</li> <li>When the inverter is in RUN mode, it decreases the speed.</li> <li>Long press (&gt; 2 s) of the key quickly scrolls down through parameter numbers, indices, or values.</li> </ul>
 + 	Reverses the direction of rotation of the motor. Pressing the two keys once activates reverse motor rotation. Pressing the two keys once again deactivates reverse rotation of the motor. The reserve icon (  ) on the display indicates that the output speed is opposite to the setpoint.

**Note**

Otherwise specified, operations of the above keys always indicate short press (< 2 s).

**Inverter status icons**

	Inverter has at least one pending fault.	
	Inverter has at least one pending alarm.	
	 :	Inverter is running (motor speed may be 0 rpm).
	 (flashing):	Inverter may be energized unexpectedly (for example, in frost protection mode).
	Motor rotates in the reversed direction.	
	 :	Inverter is in HAND mode.
	 (flashing):	Inverter is in JOG mode.

**5.1.2 Inverter menu structure**

Menu	Description
50/60 Hz selection menu	This menu is visible only on first power-up or after a factory reset.
<b>Main menu</b>	
Display menu (default display)	Basic monitoring view of key parameters such as frequency, voltage, current, DC-link voltage, and so on.
Setup menu	Access to parameters for quick commissioning of the inverter system.
Parameter menu	Access to all available inverter parameters.

5.1 The built-in Basic Operator Panel (BOP)

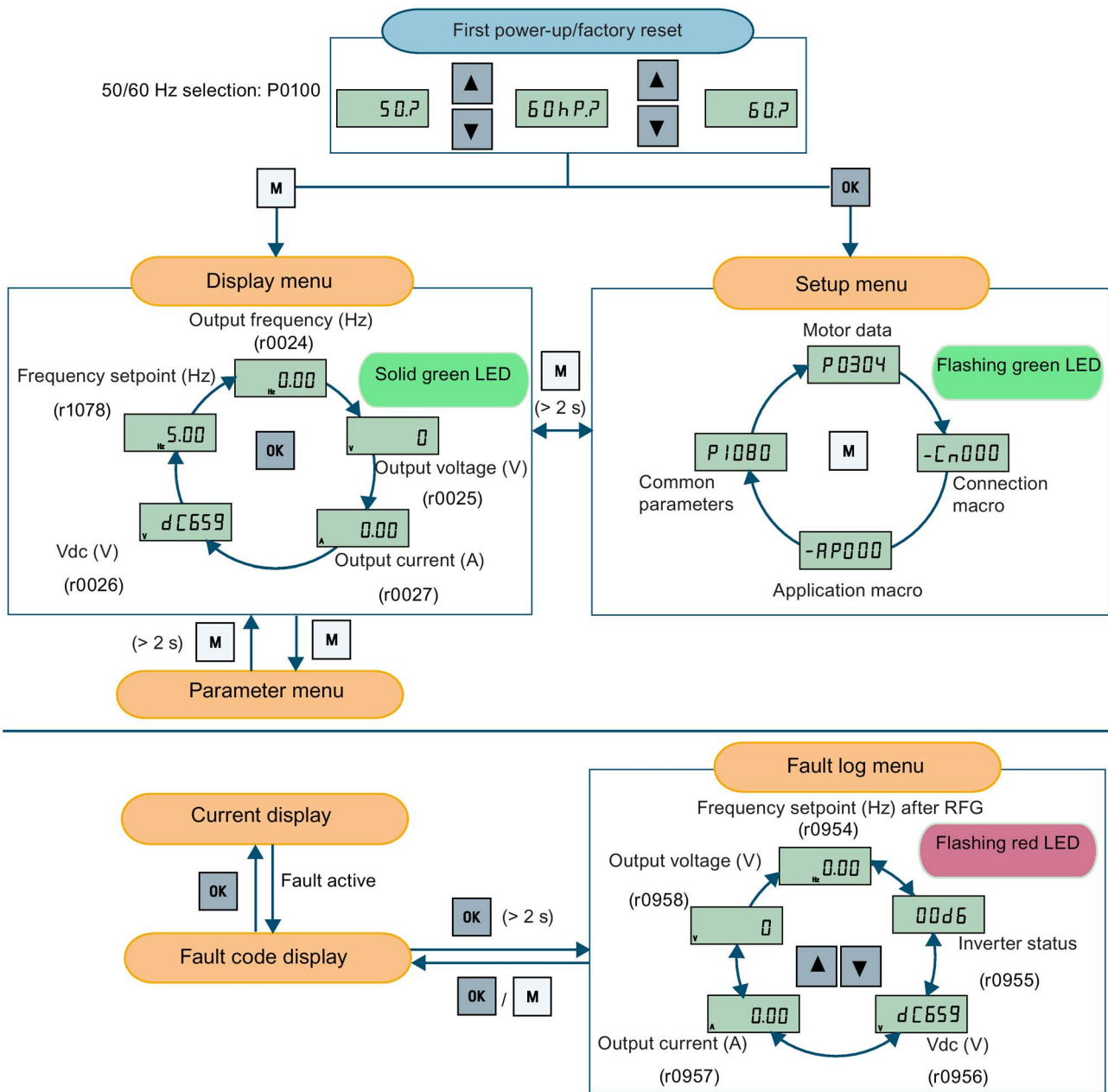



### 5.1.3 Viewing inverter status

The display menu provides a basic monitoring view of some key parameters such as frequency, voltage, current, and so on.

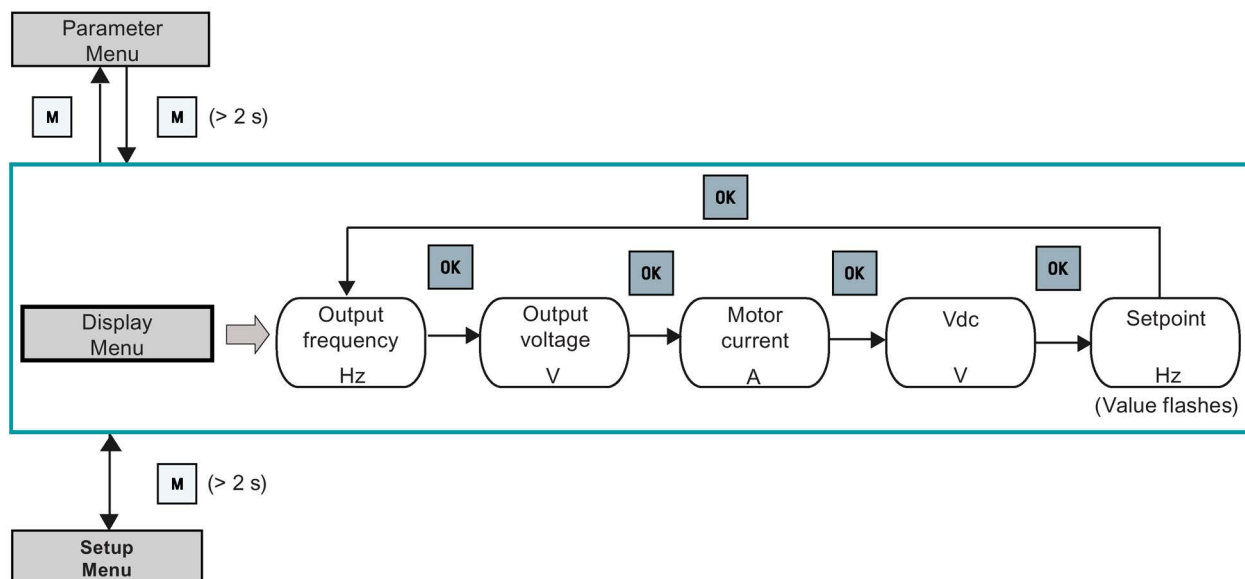

#### Note

For detailed information about the display menu structure with active faults, see Section "Faults (Page 281)".

### 5.1.4 Editing parameters

This section describes how to edit the parameters.

#### Parameter types

Parameter type		Description
CDS-dependent parameters		<ul style="list-style-type: none"> <li>Dependent on Command Data Set (CDS)</li> <li>Always indexed with [0...2]</li> <li>Available for CDS switching via P0810 and P0811</li> </ul>
DDS-dependent parameters		<ul style="list-style-type: none"> <li>Dependent on Inverter Data Set (DDS)</li> <li>Always indexed with [0...2]</li> <li>Available for DDS switching via P0820 and P0821</li> </ul>
Other parameters	Multi-indexed parameters	These parameters are indexed with the range of indices dependent on the individual parameter.
	Index-free parameters	These parameters are not indexed.

### Normal editing of parameters

#### Note

Pressing ▲ or ▼ for longer than two seconds to quickly increase or decrease the parameter numbers or indexes is only possible in the parameter menu.

This editing method is best suited when small changes are required to parameter numbers, indexes, or values.

- To increase or decrease the parameter number, index, or value, press ▲ or ▼ for less than two seconds.
- To quickly increase or decrease the parameter number, index, or value, press ▲ or ▼ for longer than two seconds.
- To confirm the setting, press **OK**.
- To cancel the setting, press **M**.

#### Example:

#### Editing parameter values

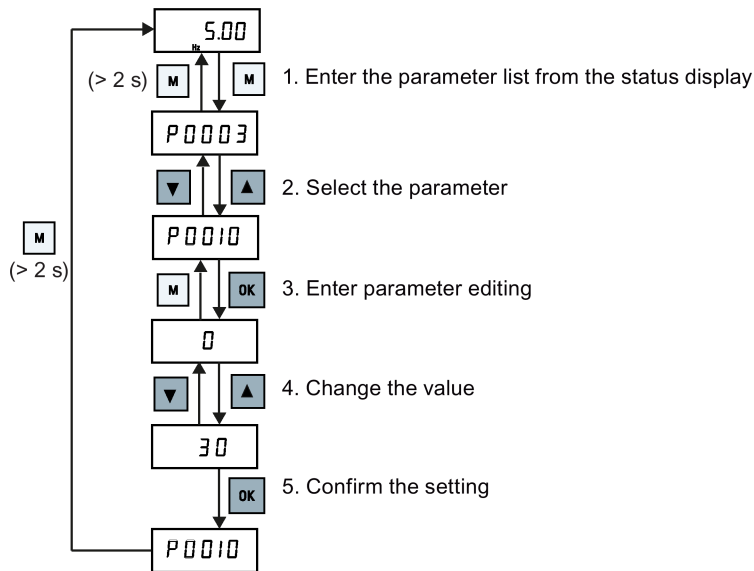







## Digit-by-digit editing

### Note

Digit-by-digit editing of parameter numbers or indexes is only possible in the parameter menu.

Digit-by-digit editing can be performed on parameter numbers, parameter indexes, or parameter values. This editing method is best suited when large changes are required to parameter numbers, indexes, or values. For information about the inverter menu structure, refer to Section "Inverter menu structure (Page 51)".

- In any edit or scroll mode, digit-by-digit editing is entered by a long press (> 2 s) on .
- The digit-by-digit editing always starts with the rightmost digit.
- Each digit is selected in turn by pressing .
- Pressing  once moves the cursor to the rightmost digit of the current item.
- Pressing  twice in succession exits the digit-by-digit mode without changing the item being edited.
- Pressing  on a digit when there are no further digits to the left saves the value.
- **If more digits are required to the left, then these must be added by scrolling the existing leftmost digit above 9 to add more digits to the left.**
- Pressing  or  for over two seconds enters fast digit scrolling.

<p><b>Example 1:</b> Editing parameter numbers</p>	<p><b>Example 2:</b> Editing parameter indices If a parameter is an array, edit indices as illustrated below:</p>	<p><b>Example 3:</b> Editing parameter values</p>
--	---	---



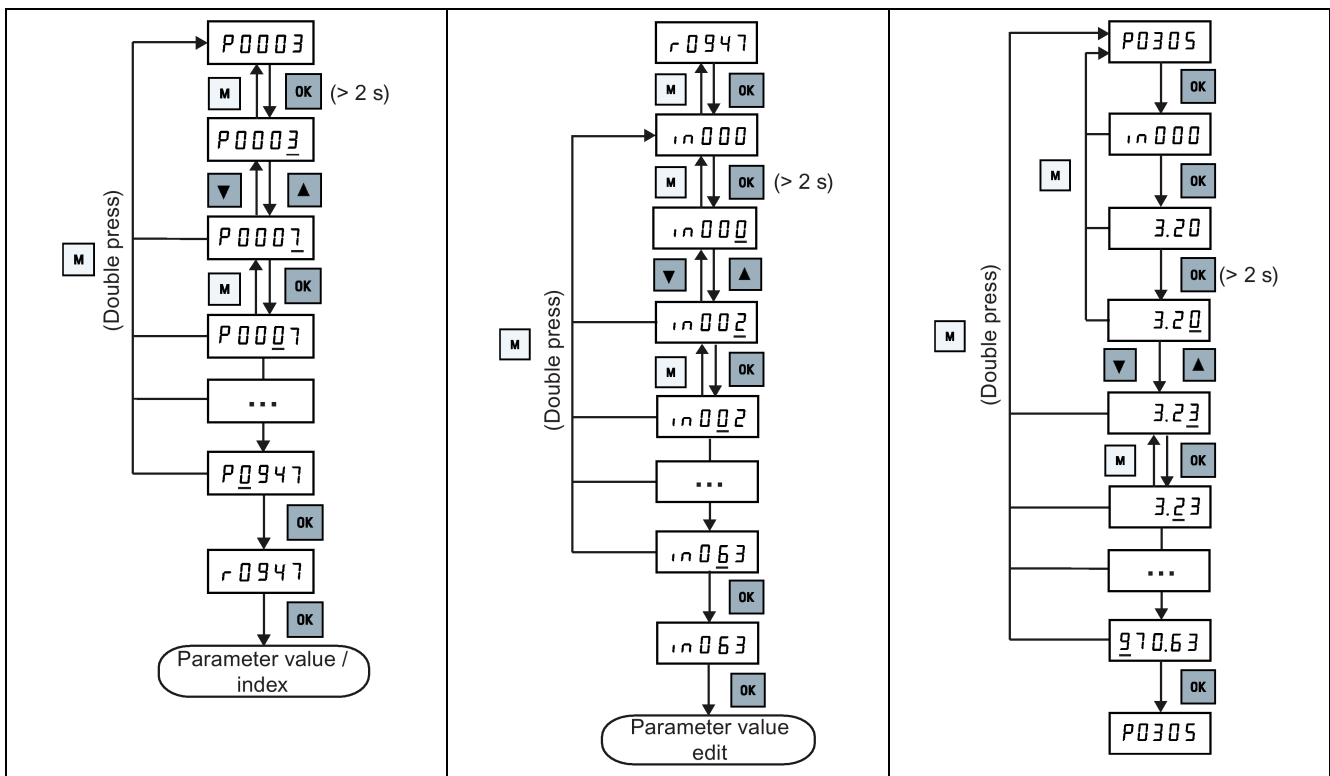

5.1 The built-in Basic Operator Panel (BOP)

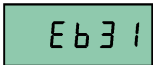
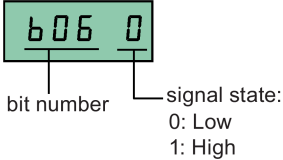
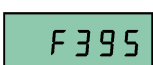
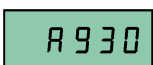
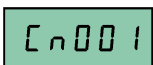

5.1.5 Screen displays

The following two tables show you basic screen displays:

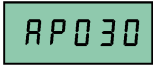
Screen information	Display	Meaning
"8 8 8 8 8"		Inverter is busy with internal data processing.
"_ _ _ _ _"		Action not completed or not possible
"Pxxxx"		Writable parameter
"rxxxx"		Read-only parameter
"inxxx"		Indexed parameter

Screen information	Display	Meaning
Hexadecimal number		Parameter value in hex format
"bxx x"		Parameter value in bit format
"Fxxx"		Fault code
"Axxx"		Alarm code
"Cnxxx"		Settable connection macro
"-Cnxxx"		Current selected connection macro
"APxxx"		Settable application macro
"-APxxx"		Current selected application macro

"A"	A	"G"	g	"N"	n	"T"	t
"B"	b	"H"	h	"O"	o	"U"	u
"C"	[	"I"	i	"P"	p	"V"	v
"D"	d	"J"	j	"Q"	q	"X"	x
"E"	E	"L"	L	"R"	r	"Y"	y
"F"	F	"M"	m	"S"	s	"Z"	z
0 to 9	0 123456789					"?"	?





### 5.1.6 LED states

The SINAMICS V20 has only one LED for status indications. The LED can display orange, green, or red.

If more than one inverter state exists, the LED displays in the following order of priority:

- Parameter cloning
- Commissioning mode
- All faults
- Ready (no fault)

For example, if there is an active fault when the inverter is in the commissioning mode, the LED flashes green at 0.5 Hz.

Inverter state	LED color	
Power up	Orange	
Ready (no fault)	Green	
Commissioning mode	Slow flashing green at 0.5 Hz	
All faults	Fast flashing red at 2 Hz	
Parameter cloning	Flashing orange at 1 Hz	

## 5.2 Checking before power-on

Perform the following checks before you power on the inverter system:

- Check that all cables have been connected correctly and that all relevant product and plant/location safety precautions have been observed.
- Ensure that the motor and the inverter are configured for the correct supply voltage.
- Tighten all screws to the specified tightening torque.

## 5.3 Setting the 50/60 Hz selection menu

### Note

The 50/60 Hz selection menu is visible only on first power-up or after a factory reset (P0970). You can make a selection using the BOP or exit the menu without making a selection, and the menu will not be displayed unless a factory reset is performed.

The motor base frequency also can be selected by changing P0100 to the desired value.

### Functionality

This menu is used to set the motor base frequency according to which region of the world that the motor is used in. The menu determines whether power settings (for example, rated motor power P0307) are expressed in [kW] or [hp].

Parameter	Value	Description
P0100	0	Motor base frequency is 50 Hz ( <b>default</b> ) → Europe [kW]
	1	Motor base frequency is 60 Hz → United States/Canada [hp]
	2	Motor base frequency is 60 Hz → United States/Canada [kW]

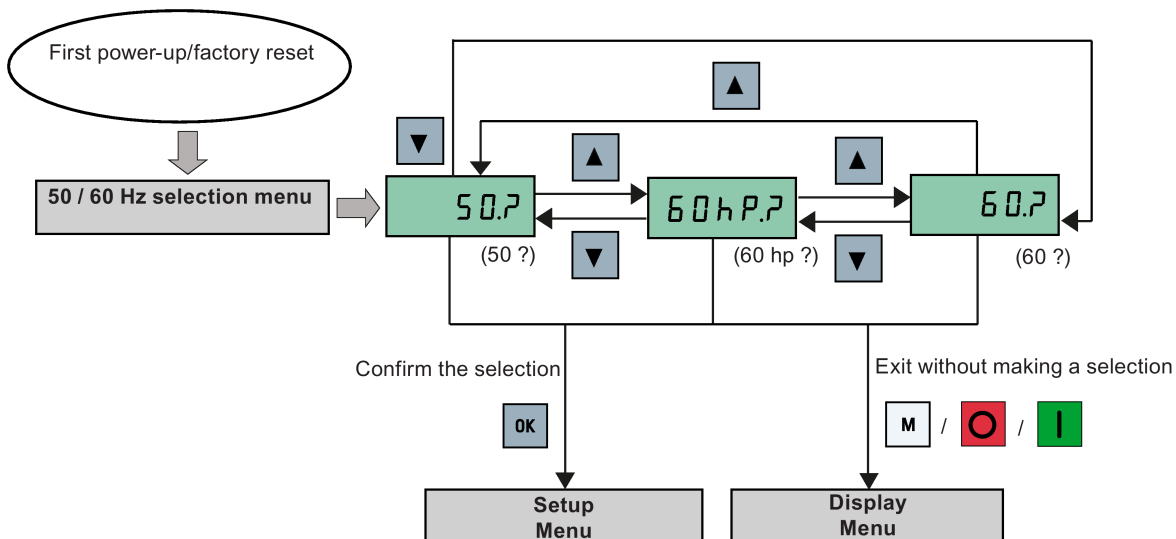

## 5.4 Starting the motor for test run

This section describes how to start the motor for a test run to check that the motor speed and rotation direction are correct.

### Note

To run the motor, the inverter must be in the display menu (default display) and power-on default state with P0700 (selection of command source) = 1.





If you are now in the setup menu (the inverter displays "P0304"), press  for over two seconds to exit the setup menu and enter the display menu.

You can start the motor in HAND or JOG mode.

### Starting the motor in HAND mode

1. Press  to start the motor.
2. Press  to stop the motor.

### Starting the motor in JOG mode

1. Press  +  to switch from HAND to JOG mode (the  icon flashes).
2. Press  to start the motor. Release  to stop the motor.

## 5.5 Quick commissioning

### 5.5.1 Quick commissioning through the setup menu

#### 5.5.1.1 Structure of the setup menu

#### Functionality of the setup menu

The setup menu guides you through the steps required for quick commissioning of the inverter system. It consists of the following four sub-menus:

	Sub-menu	Functionality
1	Motor data	Sets nominal motor parameters for quick commissioning
2	Connection macro selection	Sets macros required for standard wiring arrangements



	Sub-menu	Functionality
3	Application macro selection	Sets macros required for certain common applications
4	Common parameter selection	Sets parameters required for inverter performance optimization

### Menu structure

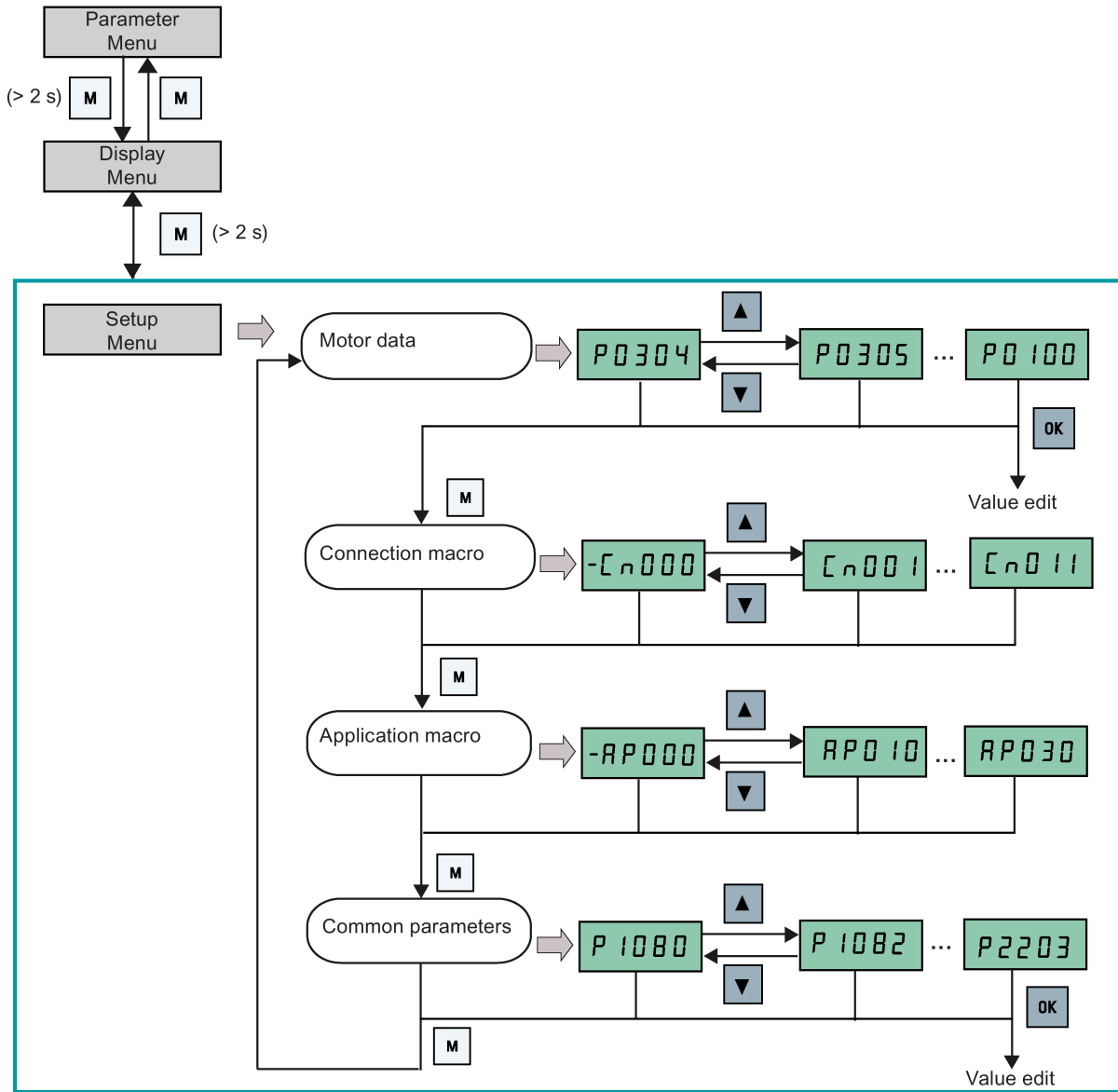

### 5.5.1.2 Setting motor data

#### Functionality

This menu is designed for easy setup of nominal motor nameplate data.







#### Text menu

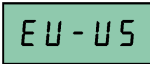

If you set P8553 to 1, parameter numbers in this menu are replaced with short text.

#### Setting parameters

##### Note

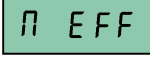
In the table below, "•" indicates that the value of this parameter must be entered according to the rating plate of the motor.

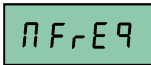
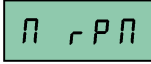
Parameter	Access level	Function	Text menu (if P8553 = 1)
P0100	1	<b>50 / 60 Hz selection</b> =0: Europe [kW], 50 Hz (factory default) =1: North America [hp], 60 Hz =2: North America [kW], 60 Hz	 (EU - US)
P0304[0] •	1	<b>Rated motor voltage [V]</b> Note that the input of rating plate data must correspond with the wiring of the motor (star / delta)	 (MOT V)
P0305[0] •	1	<b>Rated motor current [A]</b> Note that the input of rating plate data must correspond with the wiring of the motor (star / delta)	 (MOT A)
P0307[0] •	1	<b>Rated motor power [kW / hp]</b> If P0100 = 0 or 2, motor power unit = [kW] If P0100 = 1, motor power unit = [hp]	P0100 = 0 or 2:  (MOT P)
			P0100 = 1:  (MOT HP)
P0308[0] •	1	<b>Rated motor power factor (cosφ)</b> Visible only when P0100 = 0 or 2	 (M COS)
P0309[0] •	1	<b>Rated motor efficiency [%]</b> Visible only when P0100 = 1 Setting 0 causes internal calculation of value.	 (M EFF)

Parameter	Access level	Function	Text menu (if P8553 = 1)
P0310[0] •	1	Rated motor frequency [Hz]	 (M FREQ)
P0311[0] •	1	Rated motor speed [RPM]	 (M RPM)
P1900	2	<b>Select motor data identification</b> = 0: Disabled = 2: Identification of all parameters in standstill	 (MOT ID)

### 5.5.1.3 Setting connection macros

NOTICE
<p><b>Connection macro settings</b></p> <p>When commissioning the inverter, the connection macro setting is a one-off setting. Make sure that you proceed as follows before you change the connection macro setting to a value different from your last setting:</p> <ol style="list-style-type: none"> <li>1. Do a factory reset (P0010 = 30, P0970 = 1)</li> <li>2. Repeat the quick commissioning and change the connection macro</li> </ol> <p>Failure to observe may cause the inverter to accept the parameter settings from both the currently and the previously selected macros, which may lead to undefined and unexplainable inverter operation.</p> <p>However, communication parameters P2010, P2011, P2021 and P2023 for connection macros Cn010 and Cn011 are not reset automatically after a factory reset. If necessary, reset them manually.</p> <p>After changing P2023 setting for Cn010 or Cn011, power-cycle the inverter. During the power-cycle, wait until LED has gone off or the display has gone blank (may take a few seconds) before re-applying power.</p>

### Functionality

This menu selects which macro is required for standard wiring arrangements. The default one is "Cn000" for connection macro 0.

All connection macros only change the CDS0 (command data set 0) parameters. The CDS1 parameters are used for the BOP control.

Connection macro	Description	Display example
Cn000	Factory default setting. Makes no parameter changes.	  The minus sign indicates that this macro is the currently selected macro.
Cn001	BOP as the only control source	
Cn002	Control from terminals (PNP/NPN)	
Cn003	Fixed speeds	
Cn004	Fixed speed binary mode	
Cn005	Analog input and fixed frequency	
Cn006	External push button control	
Cn007	External push button with analog setpoint	
Cn008	PID control with analog input reference	
Cn009	PID control with the fixed value reference	
Cn010	USS control	
Cn011	MODBUS RTU control	

Setting connection macros

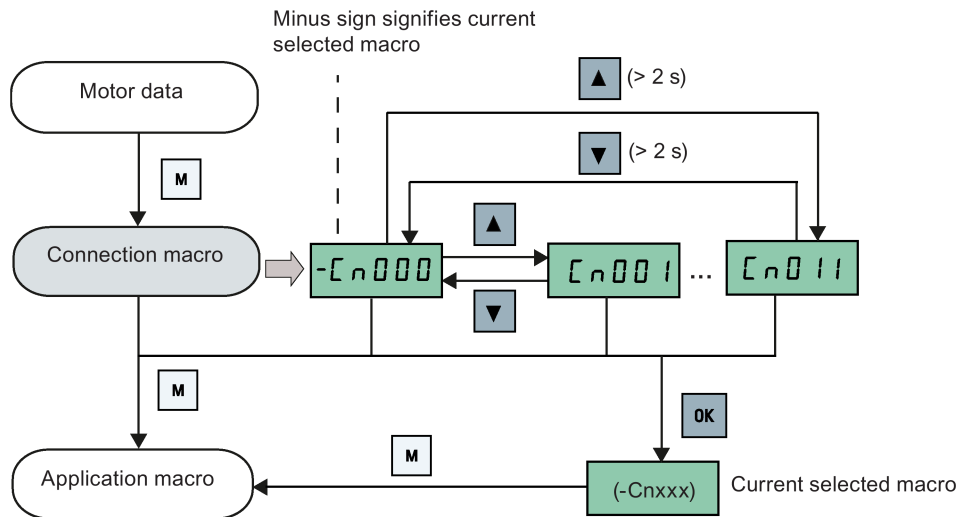

**Connection macro Cn001 - BOP as the only control source**

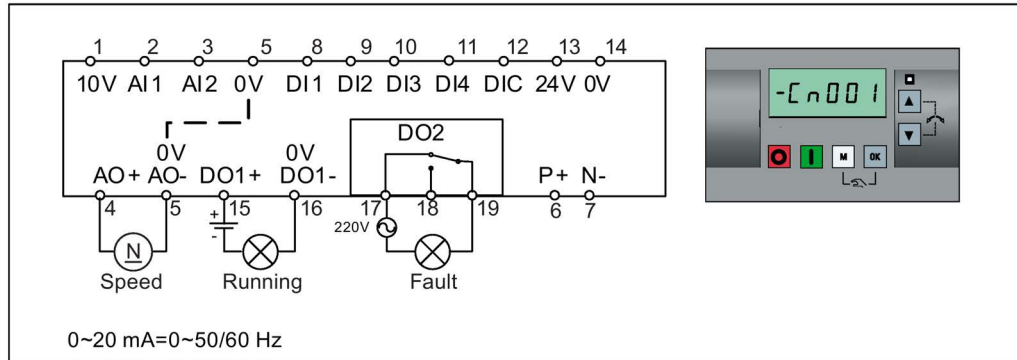

Connection macro settings:

Parameter	Description	Factory default	Default for Cn001	Remarks
P0700[0]	Selection of command source	1	1	BOP
P1000[0]	Selection of frequency	1	1	BOP MOP
P0731[0]	BI: Function of digital output 1	52.3	52.2	Inverter running
P0732[0]	BI: Function of digital output 2	52.7	52.3	Inverter fault active
P0771[0]	CI: Analog output	21	21	Actual frequency
P0810[0]	BI: CDS bit 0 (Hand/Auto)	0	0	Hand mode

**Connection macro Cn002 - Control from terminals (PNP/NPN)**

External control - Potentiometer with setpoint

- Hand/Auto switch between the BOP and terminals by pressing **M** + **OK**
- Both NPN and PNP can be realized with the same parameters. You can change the connection of the digital input common terminal to 24 V or 0 V to decide the mode.

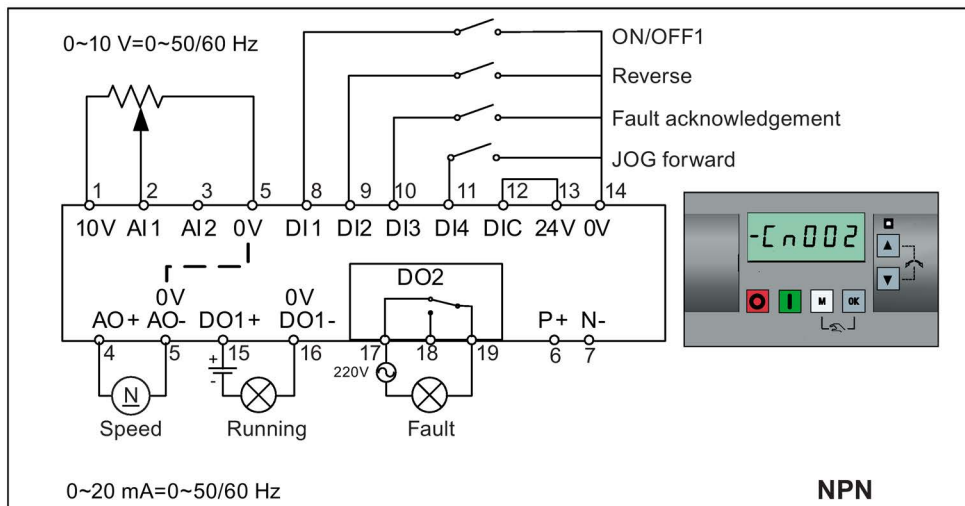
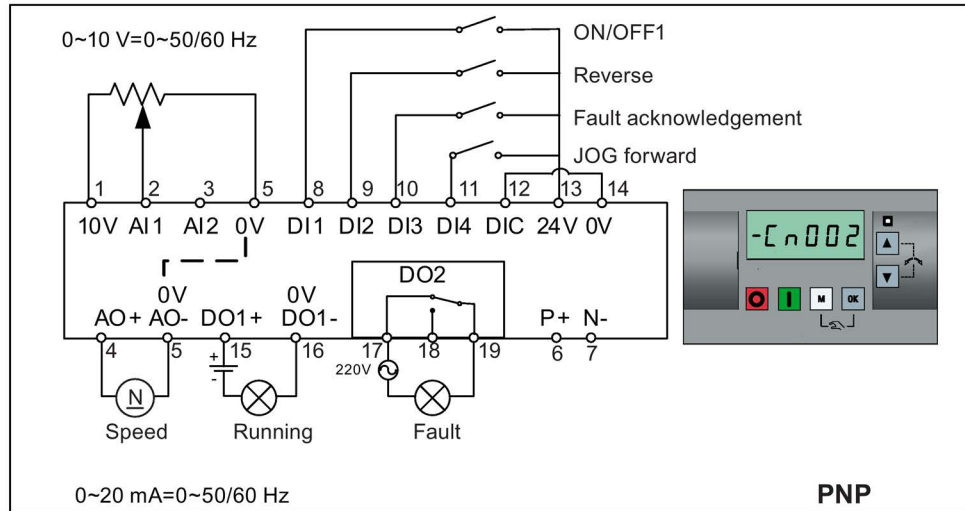

Connection macro settings:

Parameter	Description	Factory default	Default for Cn002	Remarks
P0700[0]	Selection of command source	1	2	Terminal as command source
P1000[0]	Selection of frequency	1	2	Analog as speed setpoint
P0701[0]	Function of digital input 1	0	1	ON/OFF
P0702[0]	Function of digital input 2	0	12	Reverse
P0703[0]	Function of digital input 3	9	9	Fault acknowledgement
P0704[0]	Function of digital input 4	15	10	JOG forward
P0771[0]	CI: Analog output	21	21	Actual frequency

Parameter	Description	Factory default	Default for Cn002	Remarks
P0731[0]	BI: Function of digital output 1	52.3	52.2	Inverter running
P0732[0]	BI: Function of digital output 2	52.7	52.3	Inverter fault active

### Connection macro Cn003 - Fixed speeds

Three fixed speeds with ON/OFF1

- Hand/Auto switch between the BOP and terminal by pressing **M** + **OK**
- If more than one fixed frequency is selected at the same time, the selected frequencies are summed, that is, FF1 + FF2 + FF3

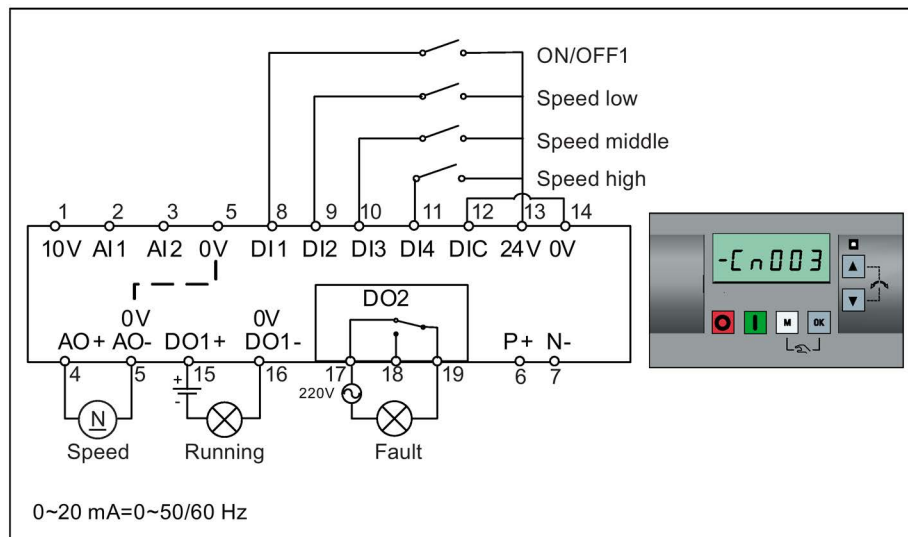

Connection macro settings:

Parameter	Description	Factory default	Default for Cn003	Remarks
P0700[0]	Selection of command source	1	2	Terminal as command source
P1000[0]	Selection of frequency	1	3	Fixed frequency
P0701[0]	Function of digital input 1	0	1	ON/OFF
P0702[0]	Function of digital input 2	0	15	Fixed speed bit 0
P0703[0]	Function of digital input 3	9	16	Fixed speed bit 1
P0704[0]	Function of digital input 4	15	17	Fixed speed bit 2
P1016[0]	Fixed frequency mode	1	1	Direct selection mode
P1020[0]	BI: Fixed frequency selection bit 0	722.3	722.1	DI2
P1021[0]	BI: Fixed frequency selection bit 1	722.4	722.2	DI3
P1022[0]	BI: Fixed frequency selection bit 2	722.5	722.3	DI4
P1001[0]	Fixed frequency 1	10	10	Speed low
P1002[0]	Fixed frequency 2	15	15	Speed middle
P1003[0]	Fixed frequency 3	25	25	Speed high
P0771[0]	CI: Analog output	21	21	Actual frequency

Parameter	Description	Factory default	Default for Cn003	Remarks
P0731[0]	BI: Function of digital output 1	52.3	52.2	Inverter running
P0732[0]	BI: Function of digital output 2	52.7	52.3	Inverter fault active

**Connection macro Cn004 - Fixed speeds in binary mode**

Fixed speeds with ON command in binary mode

- Up to 16 different fixed frequency values (0 Hz, P1001 to P1015) can be selected by the fixed frequency selectors (P1020 to P1023)

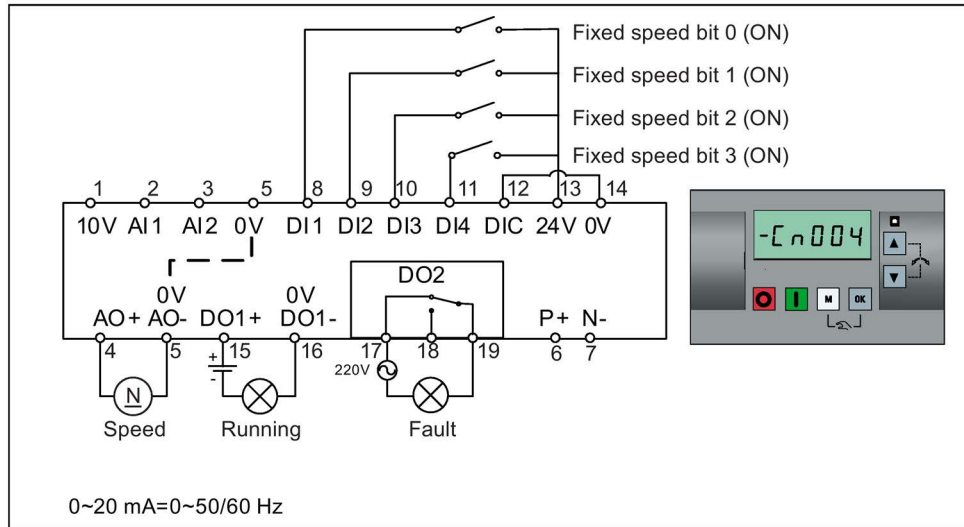

Connection macro settings:

Parameter	Description	Factory default	Default for Cn004	Remarks
P0700[0]	Selection of command source	1	2	Terminals as command source
P1000[0]	Selection of frequency	1	3	Fixed frequency
P0701[0]	Function of digital input 1	0	15	Fixed speed bit 0
P0702[0]	Function of digital input 2	0	16	Fixed speed bit 1
P0703[0]	Function of digital input 3	9	17	Fixed speed bit 2
P0704[0]	Function of digital input 4	15	18	Fixed speed bit 3
P1016[0]	Fixed frequency mode	1	2	Binary mode
P0840[0]	BI: ON/OFF1	19.0	1025.0	Inverter starts at the fixed speed selected
P1020[0]	BI: Fixed frequency selection bit 0	722.3	722.0	DI1
P1021[0]	BI: Fixed frequency selection bit 1	722.4	722.1	DI2
P1022[0]	BI: Fixed frequency selection bit 2	722.5	722.2	DI3
P1023[0]	BI: Fixed frequency selection bit 3	722.6	722.3	DI4
P0771[0]	CI: Analog output	21	21	Actual frequency



Parameter	Description	Factory default	Default for Cn004	Remarks
P0731[0]	BI: Function of digital output 1	52.3	52.2	Inverter running
P0732[0]	BI: Function of digital output 2	52.7	52.3	Inverter fault active

### Connection macro Cn005 - Analog input and fixed frequency

The analog input works as an additional setpoint.

- If digital input 2 and digital input 3 are active together, the selected frequencies are summed, that is, FF1 + FF2

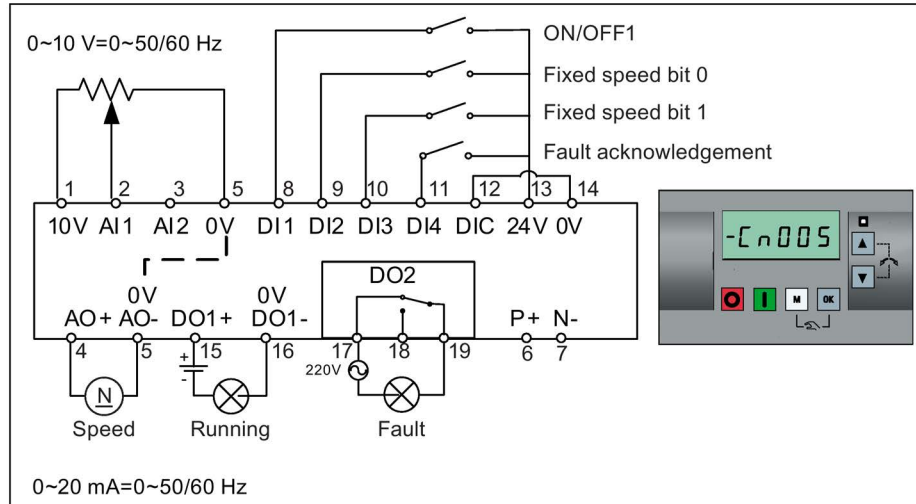

### Function diagram

When the fixed speed is selected, the additional setpoint channel from the analog input is disabled. If there is no fixed speed setpoint, the setpoint channel connects to the analog input.

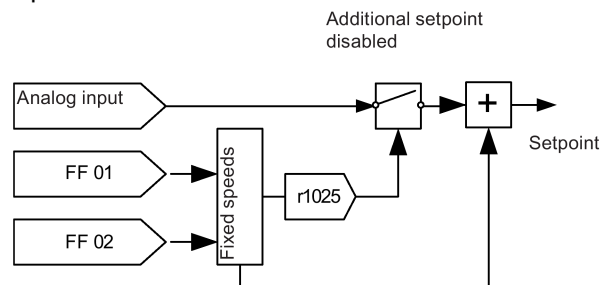

Connection macro settings:

Parameter	Description	Factory default	Default for Cn005	Remarks
P0700[0]	Selection of command source	1	2	Terminals as command source
P1000[0]	Selection of frequency	1	23	Fixed frequency + analog setpoint
P0701[0]	Function of digital input 1	0	1	ON/OFF
P0702[0]	Function of digital input 2	0	15	Fixed speed bit 0
P0703[0]	Function of digital input 3	9	16	Fixed speed bit 1
P0704[0]	Function of digital input 4	15	9	Fault acknowledgement

Parameter	Description	Factory default	Default for Cn005	Remarks
P1016[0]	Fixed frequency mode	1	1	Direct selection mode
P1020[0]	BI: Fixed frequency selection bit 0	722.3	722.1	DI2
P1021[0]	BI: Fixed frequency selection bit 1	722.4	722.2	DI3
P1001[0]	Fixed frequency 1	10	10	Fixed speed 1
P1002[0]	Fixed frequency 2	15	15	Fixed speed 2
P1074[0]	BI: Disable additional setpoint	0	1025.0	FF disables the additional setpoint
P0771[0]	CI: Analog output	21	21	Actual frequency
P0731[0]	BI: Function of digital output 1	52.3	52.2	Inverter running
P0732[0]	BI: Function of digital output 2	52.7	52.3	Inverter fault active

**Connection macro Cn006 - External push button control**

Note that the command sources are pulse signals.

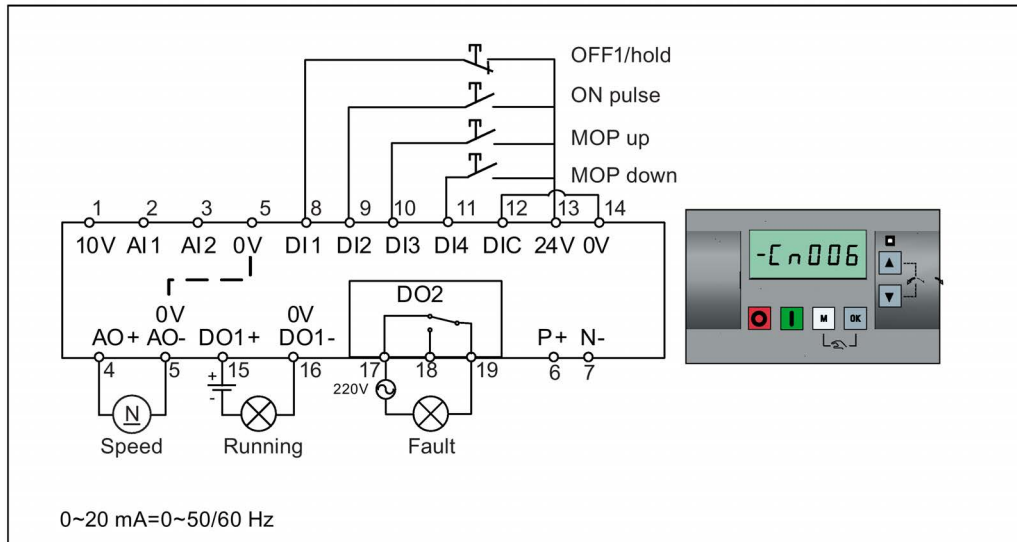

Connection macro settings:

Parameter	Description	Factory default	Default for Cn006	Remarks
P0700[0]	Selection of command source	1	2	Terminals as command source
P1000[0]	Selection of frequency	1	1	MOP as setpoint
P0701[0]	Function of digital input 1	0	2	OFF1/hold
P0702[0]	Function of digital input 2	0	1	ON pulse
P0703[0]	Function of digital input 3	9	13	MOP up pulse
P0704[0]	Function of digital input 4	15	14	MOP down pulse
P0727[0]	Selection of 2/3-wire method	0	3	3-wire ON pulse + OFF1/hold + Reverse
P0771[0]	CI: Analog output	21	21	Actual frequency
P0731[0]	BI: Function of digital output 1	52.3	52.2	Inverter running

Parameter	Description	Factory default	Default for Cn006	Remarks
P0732[0]	BI: Function of digital output 2	52.7	52.3	Inverter fault active
P1040[0]	Setpoint of the MOP	5	0	Initial frequency
P1047[0]	MOP ramp-up time of the RFG	10	10	Ramp-up time from zero to maximum frequency
P1048[0]	MOP ramp-down time of the RFG	10	10	Ramp-down time from maximum frequency to zero

### Connection macro Cn007 - External push buttons with analog control

Note that the command sources are pulse signals.

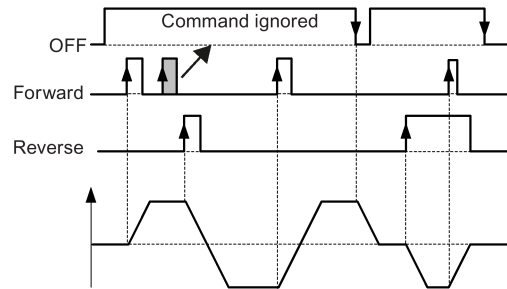
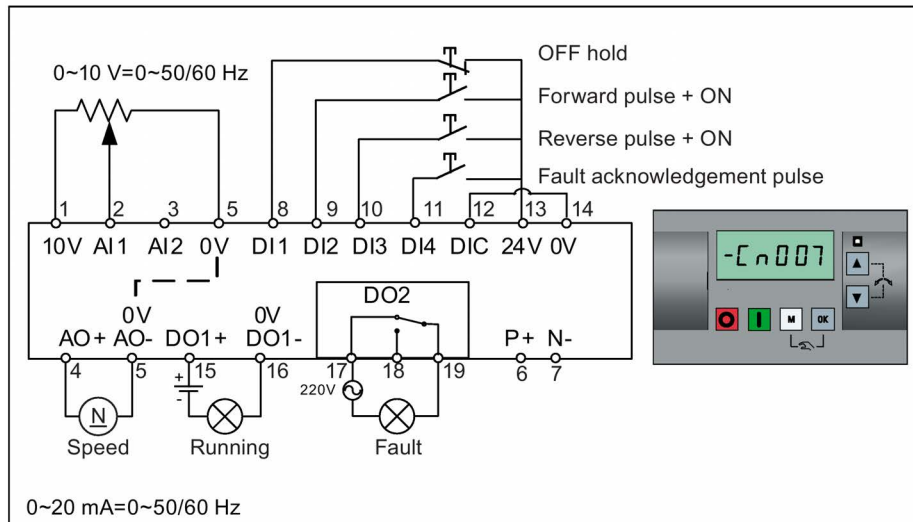

Connection macro settings:

Parameter	Description	Factory default	Default for Cn007	Remarks
P0700[0]	Selection of command source	1	2	Terminals as command source
P1000[0]	Selection of frequency	1	2	Analog
P0701[0]	Function of digital input 1	0	1	OFF hold
P0702[0]	Function of digital input 2	0	2	Forward pulse + ON
P0703[0]	Function of digital input 3	9	12	Reverse pulse + ON
P0704[0]	Function of digital input 4	15	9	Fault acknowledgement

Parameter	Description	Factory default	Default for Cn007	Remarks
P0727[0]	Selection of 2/3-wire method	0	2	3-wire STOP + Forward pulse + Reverse pulse
P0771[0]	CI: Analog output	21	21	Actual frequency
P0731[0]	BI: Function of digital output 1	52.3	52.2	Inverter running
P0732[0]	BI: Function of digital output 2	52.7	52.3	Inverter fault active

**Connection macro Cn008 - PID control with analog reference**

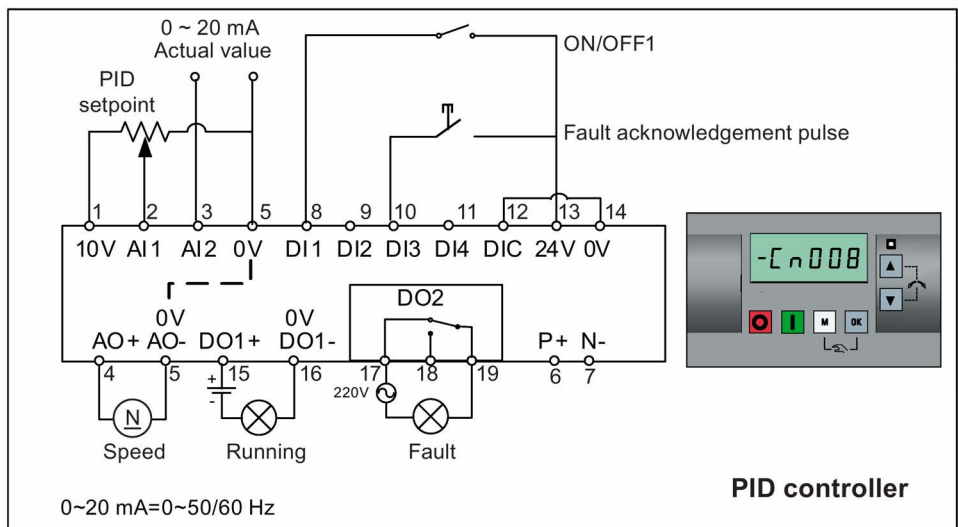

**Note**

If a negative setpoint for the PID control is desired, change the setpoint and feedback wiring as needed.

When you switch to Hand mode from PID control mode, P2200 becomes 0 to disable the PID control. When you switch it back to Auto mode, P2200 becomes 1 to enable the PID control again.

Connection macro settings:

Parameter	Description	Factory default	Default for Cn008	Remarks
P0700[0]	Selection of command source	1	2	Terminals as command source
P0701[0]	Function of digital input 1	0	1	ON/OFF
P0703[0]	Function of digital input 3	9	9	Fault acknowledgement
P2200[0]	BI: Enable PID controller	0	1	Enable PID
P2253[0]	CI: PID setpoint	0	755.0	PID setpoint = AI1
P2264[0]	CI: PID feedback	755.0	755.1	PID feedback = AI2
P0756[1]	Type of analog input	0	2	AI2, 0 mA to 20 mA
P0771[0]	CI: Analog output	21	21	Actual frequency
P0731[0]	BI: Function of digital output 1	52.3	52.2	Inverter running
P0732[0]	BI: Function of digital output 2	52.7	52.3	Inverter fault active



Connection macro Cn010 - USS control

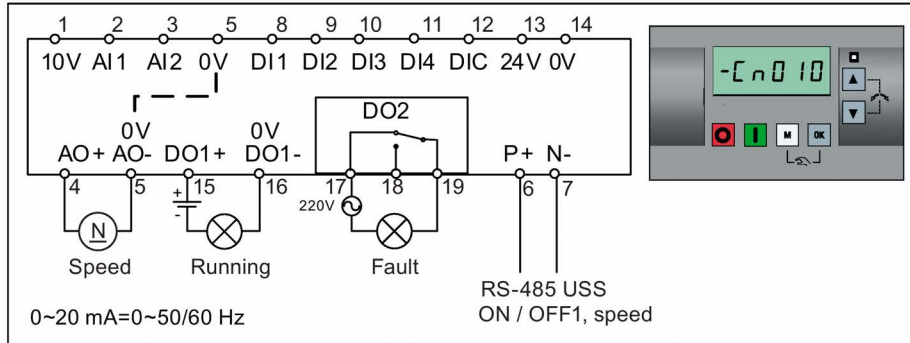

Connection macro settings:

Parameter	Description	Factory default	Default for Cn010	Remarks
P0700[0]	Selection of command source	1	5	RS485 as the command source
P1000[0]	Selection of frequency	1	5	RS485 as the speed setpoint
P2023[0]	RS485 protocol selection	1	1	USS protocol
P2010[0]	USS/MODBUS baudrate	6	8	Baudrate 38400 bps
P2011[0]	USS address	0	1	USS address for inverter
P2012[0]	USS PZD length	2	2	Number of PZD words
P2013[0]	USS PKW length	127	127	Variable PKW words
P2014[0]	USS/MODBUS telegram off time	2000	500	Time to receive data

Connection macro Cn011 - MODBUS RTU control

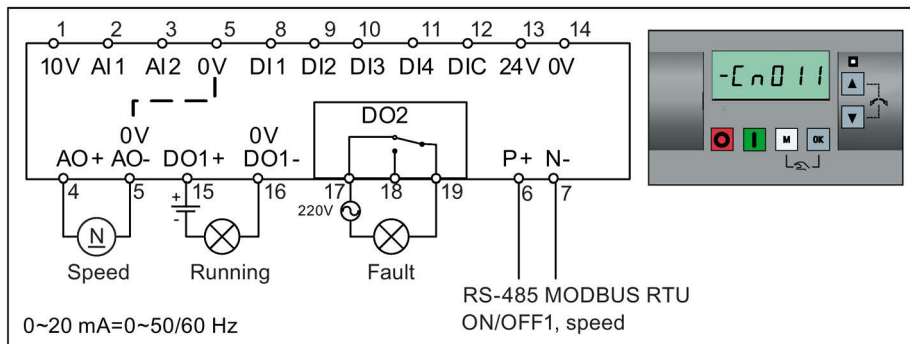

Connection macro settings:

Parameter	Description	Factory default	Default for Cn011	Remarks
P0700[0]	Selection of command source	1	5	RS485 as the command source
P1000[0]	Selection of frequency	1	5	RS485 as the speed setpoint
P2023[0]	RS485 protocol selection	1	2	MODBUS RTU protocol
P2010[0]	USS/MODBUS baudrate	6	6	Baudrate 9600 bps
P2021[0]	MODBUS address	1	1	MODBUS address for inverter

Parameter	Description	Factory default	Default for Cn011	Remarks
P2022[0]	MODBUS reply timeout	1000	1000	Maximum time to send reply back to the master
P2014[0]	USS/MODBUS telegram off time	2000	100	Time to receive data
P2034	MODBUS parity on RS485	2	2	Parity of MODBUS telegrams on RS485
P2035	MODBUS stop bits on RS485	1	1	Number of stop bits in MODBUS telegrams on RS485

### 5.5.1.4 Setting application macros

NOTICE
<p><b>Application macro settings</b></p> <p>When commissioning the inverter, the application macro setting is a one-off setting. Make sure that you proceed as follows before you change the application macro setting to a value different from your last setting:</p> <ol style="list-style-type: none"> <li>1. Do a factory reset (P0010 = 30, P0970 = 1)</li> <li>2. Repeat the quick commissioning and change the application macro</li> </ol> <p>Failure to observe may cause the inverter to accept the parameter settings from both the currently and the previously selected macros, which may lead to undefined and unexplainable operation.</p>

### Functionality

This menu defines certain common applications. Each application macro provides a set of parameter settings for a specific application. After you select an application macro, the corresponding settings are applied to the inverter to simplify the commissioning process.

The default application macro is "AP000" for application macro 0. If none of the application macros fits your application, select the one that is the closest to your application and make further parameter changes as desired.

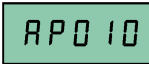
Application macro	Description	Display example
AP000	Factory default setting. Makes no parameter changes.	  <p>The minus sign indicates that this macro is the currently selected macro.</p>
AP010	Simple pump applications	
AP020	Simple fan applications	
AP021	Compressor applications	
AP030	Conveyor applications	

### Setting application macros

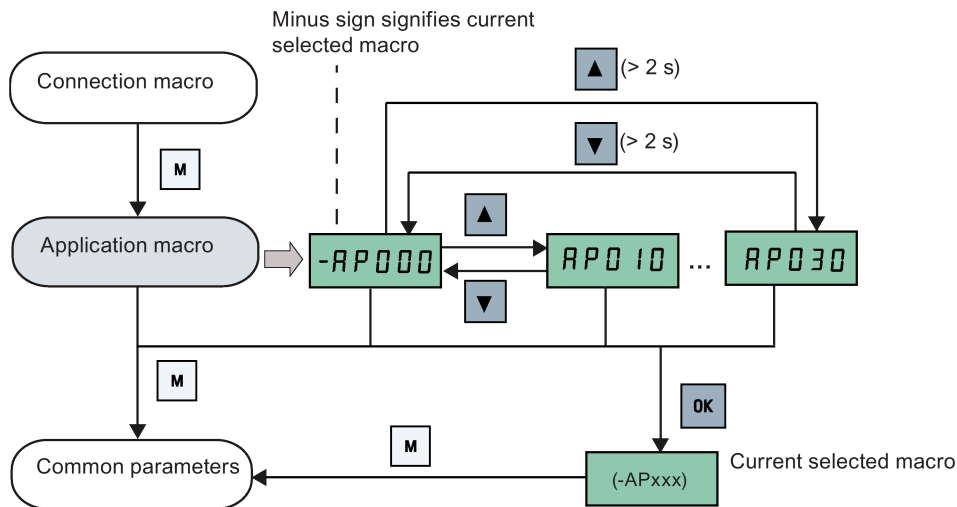

### Application macro AP010 - Simple pump applications

Parameter	Description	Factory default	Default for AP010	Remarks
P1080[0]	Minimum frequency	0	15	Inverter running at a lower speed inhibited
P1300[0]	Control mode	0	7	Quadratic V/f
P1110[0]	BI: Inhibit negative frequency setpoint	0	1	Reverse pump rotation inhibited
P1210[0]	Automatic restart	1	2	Fault acknowledgement at power-on
P1120[0]	Ramp-up time	10	10	Ramp-up time from zero to maximum frequency
P1121[0]	Ramp-down time	10	10	Ramp-down time from maximum frequency to zero

### Application macro AP020 - Simple fan applications

Parameter	Description	Factory default	Default for AP020	Remarks
P1110[0]	BI: Inhibit negative frequency setpoint	0	1	Reverse fan rotation inhibited
P1300[0]	Control mode	0	7	Quadratic V/f
P1200[0]	Flying start	0	2	Search for the speed of the running motor with a heavy inertia load so that the motor runs up to the setpoint
P1210[0]	Automatic restart	1	2	Fault acknowledgement at power-on
P1080[0]	Minimum frequency	0	20	Inverter running at a lower speed inhibited



Parameter	Description	Factory de- fault	Default for AP020	Remarks
P1120[0]	Ramp-up time	10	10	Ramp-up time from zero to maximum frequency
P1121[0]	Ramp-down time	10	20	Ramp-down time from maximum frequency to zero

### Application macro AP021 - Compressor applications

Parameter	Description	Factory de- fault	Default for AP021	Remarks
P1300[0]	Control mode	0	0	Linear V/f
P1080[0]	Minimum frequency	0	10	Inverter running at a lower speed inhibited
P1312[0]	Starting boost	0	30	Boost only effective when accelerating for the first time (standstill)
P1311[0]	Acceleration boost	0	0	Boost only effective when accelerating or braking
P1310[0]	Continuous boost	50	50	Additional boost over the complete frequency range
P1120[0]	Ramp-up time	10	10	Ramp-up time from zero to maximum frequency
P1121[0]	Ramp-down time	10	10	Ramp-down time from maximum frequency to zero

### Application macro AP030 - Conveyor applications

Parameter	Description	Factory de- fault	Default for AP030	Remarks
P1300[0]	Control mode	0	1	V/f with FCC
P1312[0]	Starting boost	0	30	Boost only effective when accelerating for the first time (standstill)
P1120[0]	Ramp-up time	10	5	Ramp-up time from zero to maximum frequency
P1121[0]	Ramp-down time	10	5	Ramp-down time from maximum frequency to zero

### 5.5.1.5 Setting common parameters





#### Functionality

This menu provides some common parameters for inverter performance optimization.

#### Text menu

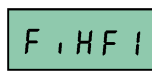
If you set P8553 to 1, parameter numbers in this menu are replaced with short text.

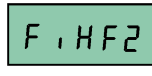
#### Setting parameters

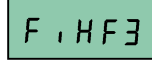
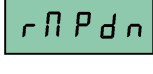
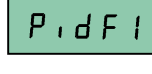
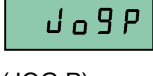
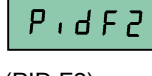
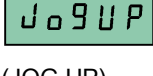
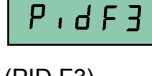
Parameter	Access level	Function	Text menu (if P8553 = 1)	Parameter	Access level	Function	Text menu (if P8553 = 1)
P1080[0]	1	Minimum motor frequency	 (MIN F)	P1001[0]	2	Fixed frequency setpoint 1	 (FIX F1)
P1082[0]	1	Maximum motor frequency	 (MAX F)	P1002[0]	2	Fixed frequency setpoint 2	 (FIX F2)
P1120[0]	1	Ramp-up time	 (RMP UP)	P1003[0]	2	Fixed frequency setpoint 3	 (FIX F3)
P1121[0]	1	Ramp-down time	 (RMP DN)	P2201[0]	2	Fixed PID frequency setpoint 1	 (PID F1)
P1058[0]	2	JOG frequency	 (JOG P)	P2202[0]	2	Fixed PID frequency setpoint 2	 (PID F2)
P1060[0]	2	JOG ramp-up time	 (JOG UP)	P2203[0]	2	Fixed PID frequency setpoint 3	 (PID F3)

## 5.5.2 Quick commissioning through the parameter menu

As an alternative to quick commissioning through the setup menu, commissioning using the parameter menu provides the other solution for quick commissioning. This would be helpful for those who are used to commissioning the inverter in this way.

### Setting parameters

#### Note

In the table below, "●" indicates that the value of this parameter must be entered according to the rating plate of the motor.

Parameter	Function	Setting
P0003	User access level	= 3 (Expert access level)
P0010	Commissioning parameter	= 1 (quick commissioning)
P0100	50 / 60 Hz selection	Set a value, if necessary: =0: Europe [kW], 50 Hz (factory default) =1: North America [hp], 60 Hz =2: North America [kW], 60 Hz
P0304[0] ●	Rated motor voltage [V]	Range: 10 to 2000 <b>Note:</b> The input of rating plate data must correspond with the wiring of the motor (star / delta)
P0305[0] ●	Rated motor current [A]	Range: 0.01 to 10000 <b>Note:</b> The input of rating plate data must correspond with the wiring of the motor (star / delta)
P0307[0] ●	Rated motor power [kW / hp]	Range: 0.01 to 2000.0 <b>Note:</b> If P0100 = 0 or 2, motor power unit = [kW] If P0100 = 1, motor power unit = [hp]
P0308[0] ●	Rated motor power factor (cosφ)	Range: 0.000 to 1.000 <b>Note:</b> This parameter is visible only when P0100 = 0 or 2
P0309[0] ●	Rated motor efficiency [%]	Range: 0.0 to 99.9 <b>Note:</b> Visible only when P0100 = 1 Setting 0 causes internal calculation of value.
P0310[0] ●	Rated motor frequency [Hz]	Range: 12.00 to 550.00
P0311[0] ●	Rated motor speed [RPM]	Range: 0 to 40000
P0335[0]	Motor cooling	Set according to the actual motor cooling method = 0: Self-cooled (factory default) = 1: Force-cooled = 2: Self-cooled and internal fan = 3: Force-cooled and internal fan

Parameter	Function	Setting
P0640[0]	Motor overload factor [%]	Range: 10.0 to 400.0 (factory default: 150.0) <b>Note:</b> The parameter defines motor overload current limit relative to P0305 (rated motor current).
P0700[0]	Selection of command source	= 0: Factory default setting = 1: Operator panel (factory default) = 2: Terminal = 5: USS / MODBUS on RS485
P1000[0]	Selection of frequency setpoint	Range: 0 to 77 (factory default: 1) = 0: No main setpoint = 1: MOP setpoint = 2: Analog setpoint = 3: Fixed frequency = 5: USS/MODBUS on RS485 = 7: Analog setpoint 2 For additional settings, see Chapter "Parameter list (Page 147)".
P1080[0]	Minimum frequency [Hz]	Range: 0.00 to 550.00 (factory default: 0.00) <b>Note:</b> The value set here is valid for both clockwise and counter-clockwise rotation.
P1082[0]	Maximum frequency [Hz]	Range: 0.00 to 550.00 (factory default: 50.00) <b>Note:</b> The value set here is valid for both clockwise and counter-clockwise rotation
P1120[0]	Ramp-up time [s]	Range: 0.00 to 650.00 (factory default: 10.00) <b>Note:</b> The value set here means the time taken for motor to accelerate from standstill up to the maximum motor frequency (P1082) when no rounding is used.
P1121[0]	Ramp-down time [s]	Range: 0.00 to 650.00 (factory default: 10.00) <b>Note:</b> The value set here means the time taken for motor to decelerate from the maximum motor frequency (P1082) down to standstill when no rounding is used.
P1300[0]	Control mode	= 0: V/f with linear characteristic (factory default) = 1: V/f with FCC = 2: V/f with quadratic characteristic = 3: V/f with programmable characteristic = 4: V/f with linear eco = 5: V/f for textile applications = 6: V/f with FCC for textile applications = 7: V/f with quadratic eco = 19: V/f control with independent voltage setpoint

Parameter	Function	Setting
P3900	End of quick commissioning	= 0: No quick commissioning (factory default) = 1: End quick commissioning with factory reset = 2: End quick commissioning = 3: End quick commissioning only for motor data <b>Note:</b> After completion of calculation, P3900 and P0010 are automatically reset to their original value 0. The inverter displays "8.8.8.8.8" which indicates that it is busy with internal data processing.
P1900	Select motor data identification	= 0: Disabled = 2: Identification of all parameters in standstill

## 5.6 Function commissioning

### 5.6.1 Overview of inverter functions

The list below provides an overview of the main functions that the SINAMICS V20 supports. For detailed description of individual parameters, see Chapter "Parameter list (Page 147)".

- 2/3 wire control (P0727)
- 50/60 Hz customization (Page 59) (P0100)
- Adjustable PWM modulation (P1800 to P1803)
- Analog input terminal function control (P0712, P0713, r0750 to P0762)
- Analog output terminal function control (P0773 to r0785)
- Automatic restart (Page 117) (P1210, P1211)
- BICO function (r3978)
- Blockage clearing mode (Page 111) (P3350 to P3353, P3361 to P3364)
- Cavitation protection (Page 125) (P2360 to P2362)
- Command and setpoint source selection (P0700, P0719, P1000 to r1025, P1070 to r1084)
- Command data set (CDS) and inverter data set (DDS) (r0050, r0051, P0809 to P0821)
- Condensation protection (Page 119) (P3854)
- Continuous boost, acceleration boost and starting boost level control (Page 87) (P1310 to P1316)
- DC coupling function (Page 128)
- DC-link voltage control (Page 104) (P0210, P1240 to P1257)
- Digital input terminal function control (P0701 to P0713, r0722, r0724)
- Digital output terminal function control (P0731, P0732, P0747, P0748)
- Dual ramp operation (Page 127) (r1119 to r1199, P2150 to P2166)
- Economy mode (Page 113) (P1300, r1348)

- Energy consumption monitoring (r0039, P0040, P0042, P0043)
- Fault and warning reaction setting (r0944 to P0952, P2100 to P2120, r3113, P3981)
- Flying start (Page 116) (P1200 to r1204)
- Free function blocks (FFBs) (Page 115) (P2800 to P2890)
- Frost protection (Page 118) (P3852, P3853)
- Hammer start mode (Page 109) (P3350 to P3354, P3357 to P3360)
- High/low overload (HO/LO) modes (Page 131) (P0205)

A new parameter P0205 is added to enable the HO/LO selection for heavy/low load applications.

- I<sub>max</sub> control (Page 102) (P1340 to P1346)
- Inverter keep-running operation (P0503)
- Inverter status at fault (Page 281) (r0954, r0955, r0956, r0957 and r0958)

This function enables you to read the relevant fault information through parameters concerned.

- JOG mode operation (Page 86) (P1055 to P1061)
- List of modified parameters (P0004)

A new value is added to parameter P0004 to enable the parameter filter which allows you to view the modified parameters.

- MODBUS parity/stop bit selection (P2034, P2035)

New parameters P2034 and P2035 are added to enable MODBUS parity/stop bit selection.

- Motor blocking, load missing, belt failure detection (Page 105) (P2177 to r2198)
- Motor brake controls (Page 91) (holding brake, DC brake, compound brake and dynamic brake) (P1212 to P1237)
- Motor frequency display scaling (P0511, r0512)
- Motor staging (Page 122) (P2370 to P2380)
- Motorized potentiometer (MOP) mode selection (P1031 to r1050)
- ON/OFF2 function for digital inputs (P0701)

A new value is added to parameter P0701 to run the motor with the ON command or cancel the inverter pulses with the OFF2 command.

- Parameter cloning (Page 301) (P0802 to P0804, P8458)
- PID controller (Page 89) (P2200 to P2355)
- Pre-configured connection macros and application macros (P0507, P0717) (see also "Setting connection macros (Page 63)" and "Setting application macros (Page 75)".)
- Programmable V/f coordinates (P1320 to P1333)
- Protection of user-defined parameters (P0011, P0012, P0013)
- Skip frequency and resonance damping (P1091 to P1101, P1338)
- Sleep (hibernation) mode (Page 120) (P2365 to P2367)
- Slip compensation (P1334 to P1338)

- Super torque mode (Page 107) (P3350 to P3356)
- Text menu display (P8553) (see also "Setting motor data (Page 62)" and "Setting common parameters (Page 78)".)
- User access level control (P0003)
- USS/MODBUS communication on RS485 (P2010 to P2037) (Page 133)
- Various stop mode selection (Page 83) (P0840 to P0886)
- Wobble function (Page 121) (P2940 to r2955)

## 5.6.2 Commissioning basic functions

### 5.6.2.1 Selecting the stop mode

#### Functionality

Both the inverter and the user have to respond to a wide range of situations and stop the inverter if necessary. Thus operating requirements as well as inverter protective functions (e.g. electrical or thermal overload), or rather man-machine protective functions, have to be taken into account. Due to the different OFF functions (OFF1, OFF2, OFF3) the inverter can flexibly respond to the mentioned requirements. Note that after an OFF2 / OFF3 command, the inverter is in the state "ON inhibit". To switch the motor on again, you need a signal low → high of the ON command.

#### OFF1

The OFF1 command is closely coupled to the ON command. When the ON command is withdrawn, OFF1 is directly activated. The inverter is braked by OFF1 with the ramp-down time P1121. If the output frequency falls below the parameter value P2167 and if the time in P2168 has expired, then the inverter pulses are cancelled.

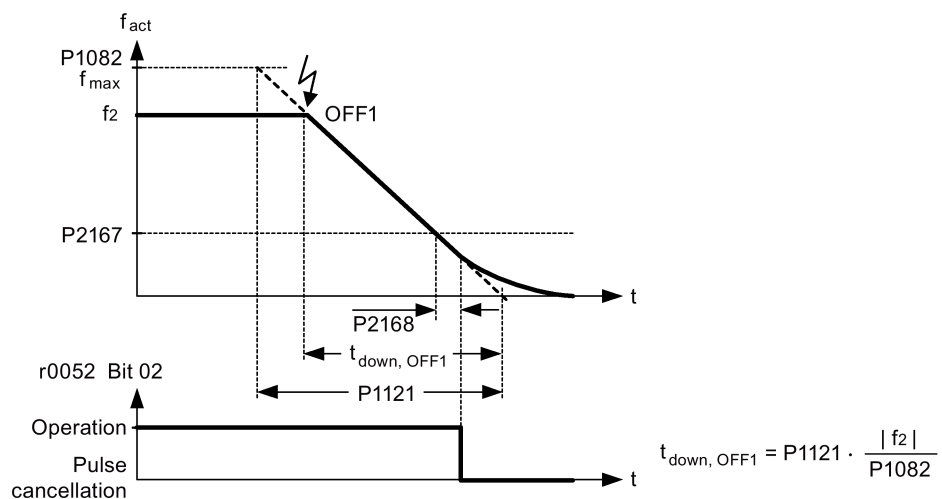

**Note**

- OFF1 can be entered using a wide range of command sources via BICO parameter P0840 (BI: ON / OFF1) and P0842 (BI: ON / OFF1 with reversing).
- BICO parameter P0840 is pre-assigned by defining the command source using P0700.
- The ON and the following OFF1 command must have the same source.
- If the ON / OFF1 command is set for more than one digital input, then only the digital input, that was last set, is valid.
- OFF1 is active low.
- When various OFF commands are selected simultaneously, the following priority applies: OFF2 (highest priority) – OFF3 – OFF1.
- OFF1 can be combined with DC current braking or compound braking.
- When the motor holding brake MHB (P1215) is activated, for an OFF1, P2167 and P2168 are not taken into account.

**OFF2**

The inverter pulses are immediately cancelled by the OFF2 command. Thus the motor coasts down and it is not possible to stop in a controlled way.

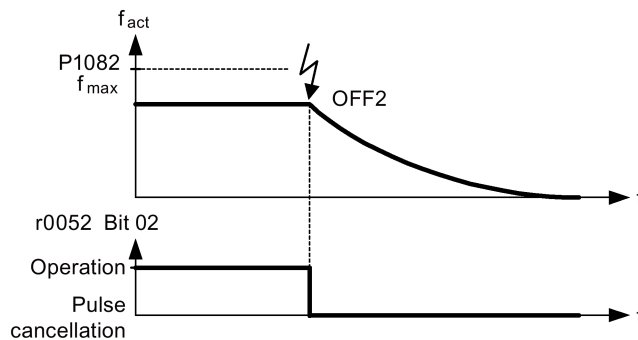
**Note**

- The OFF2 command can have one or several sources. The command sources are defined using BICO parameters P0844 (BI: 1. OFF2) and P0845 (BI: 2. OFF2).
- As a result of the pre-assignment (default setting), the OFF2 command is set to the BOP. This source is still available even if another command source is defined (e.g. terminal as command source → P0700 = 2 and OFF2 is selected using digital input 2 → P0702 = 3).
- OFF2 is active low.
- When various OFF commands are selected simultaneously, the following priority applies: OFF2 (highest priority) – OFF3 – OFF1.



## OFF3

The braking characteristics of OFF3 are identical with those of OFF1 with the exception of the independent OFF3 ramp-down time P1135. If the output frequency falls below parameter value P2167 and if the time in P2168 has expired, then the inverter pulses are cancelled as for the OFF1 command.

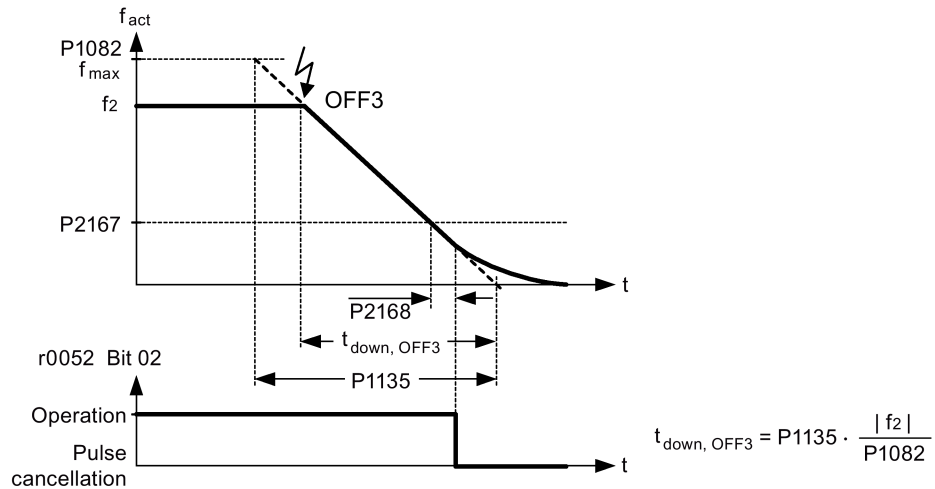

### Note

- OFF3 can be entered using a wide range of command sources via BICO parameters P0848 (BI: 1. OFF3) and P0849 (BI: 2. OFF3).
- OFF3 is active low.
- When various OFF commands are selected simultaneously, the following priority applies: OFF2 (highest priority) – OFF3 – OFF1

### 5.6.2.2 Running the inverter in JOG mode

#### Functionality

The JOG function can be controlled by either the (built-in) BOP or the digital inputs. When controlled by the BOP, pressing the RUN button will cause the motor to start and rotate at the pre-set JOG frequency (P1058). The motor stops when the RUN button is released.

When using the digital inputs as the JOG command source, the JOG frequency is set by P1058 for JOG right and P1059 for JOG left.

The JOG function allows:

- to check the functionality of the motor and inverter after commissioning has been completed (first traversing motion, checking the direction of rotation, etc.)
- to bring a motor or a motor load into a specific position
- to traverse a motor, e.g. after a program has been interrupted

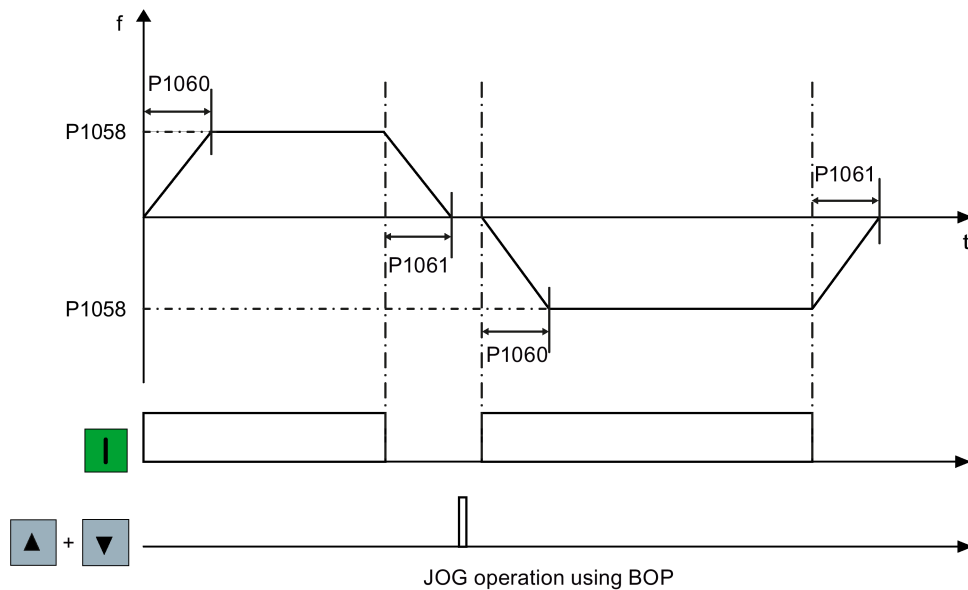

#### Setting parameters

Parameter	Function	Setting
P1055[0...2]	BI: Enable JOG right	This parameter defines source of JOG right when P0719 = 0 (Auto selection of command / setpoint source). Factory default: 19.8
P1056[0...2]	BI: Enable JOG left	This parameter defines source of JOG left when P0719 = 0 (Auto selection of command / setpoint source). Factory default: 0
P1057	JOG enable	= 1: Jogging is enabled (default)
P1058[0...2]	JOG frequency [Hz]	This parameter determines the frequency at which the inverter will run while jogging is active. Range: 0.00 to 550.00 (factory default: 5.00)
P1059[0...2]	JOG frequency left [Hz]	This parameter determines the frequency at which the inverter will run while JOG left is selected. Range: 0.00 to 550.00 (factory default: 5.00)

Parameter	Function	Setting
P1060[0...2]	JOG ramp-up time [s]	This parameter sets jog ramp-up time which is used while jogging is active. Range: 0.00 to 650.00 (factory default: 10.00)
P1061[0...2]	JOG ramp-down time [s]	This parameter sets jog ramp-down time which is used while jogging is active. Range: 0.00 to 650.00 (factory default: 10.00)

### 5.6.2.3 Setting the voltage boost

#### Functionality

For low output frequencies, the V/f characteristics only give a low output voltage. The ohmic resistances of the stator winding play a role at low frequencies, which are neglected when determining the motor flux in V/f control. This means that the output voltage can be too low in order to:

- implement the magnetization of the asynchronous motor
- hold the load
- overcome losses in the system.

The output voltage can be increased (boosted) in the inverter using the parameters as shown in the table below.

Parameter	Boost type	Description
P1310	Continuous boost [%]	<p>This parameter defines boost level relative to P0305 (rated motor current) applicable to both linear and quadratic V/f curves. Range: 0.0 to 250.0 (factory default: 50.0)</p> <p>The voltage boost is effective over the complete frequency range whereby the value continually decreases at high frequencies.</p>

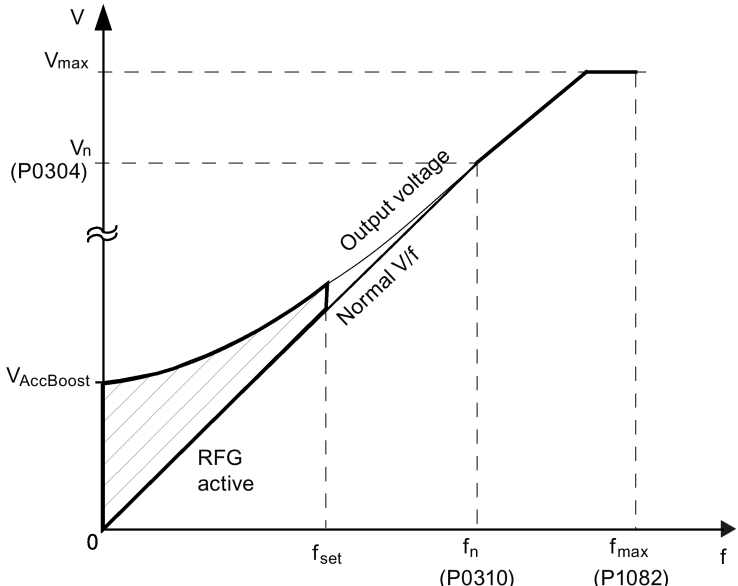
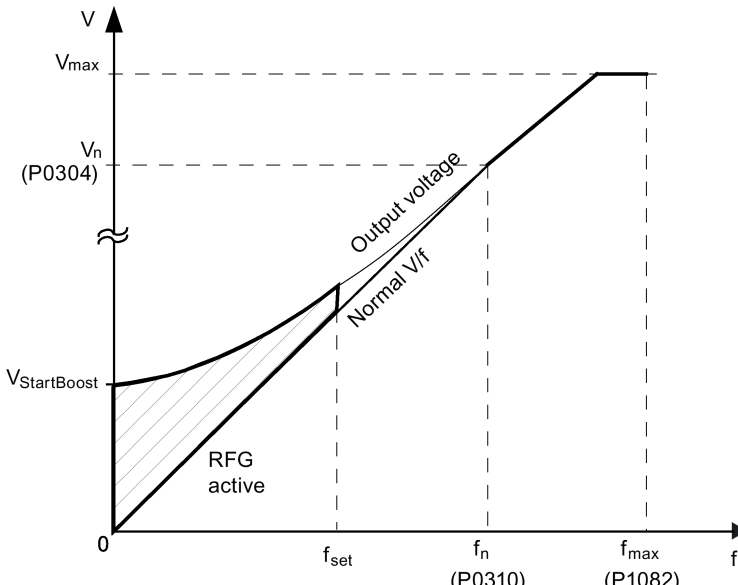
Parameter	Boost type	Description
P1311	Acceleration boost [%]	<p>This parameter applies boost relative to P0305 (rated motor current) following a positive setpoint change and drops back out once the setpoint is reached.</p> <p>Range: 0.0 to 250.0 (factory default: 0.0)</p> <p>The voltage boost is only effective when accelerating or braking.</p> 
P1312	Starting boost [%]	<p>This parameter applies a constant linear offset relative to P0305 (rated motor current) to active V/f curve (either linear or quadratic) after an ON command and is active until:</p> <ul style="list-style-type: none"> <li>• ramp output reaches setpoint for the first time respectively</li> <li>• setpoint is reduced to less than present ramp output</li> </ul> <p>Range: 0.0 to 250.0 (factory default: 0.0)</p> <p>The voltage boost is only effective when accelerating for the first time (stand-still).</p> 

### 5.6.2.4 Setting the PID controller

#### Functionality

The integrated PID controller (technology controller) supports all kinds of simple process control tasks, e.g. controlling pressures, levels, or flowrates. The PID controller specifies the speed setpoint of the motor in such a way that the process variable to be controlled corresponds to its setpoint.

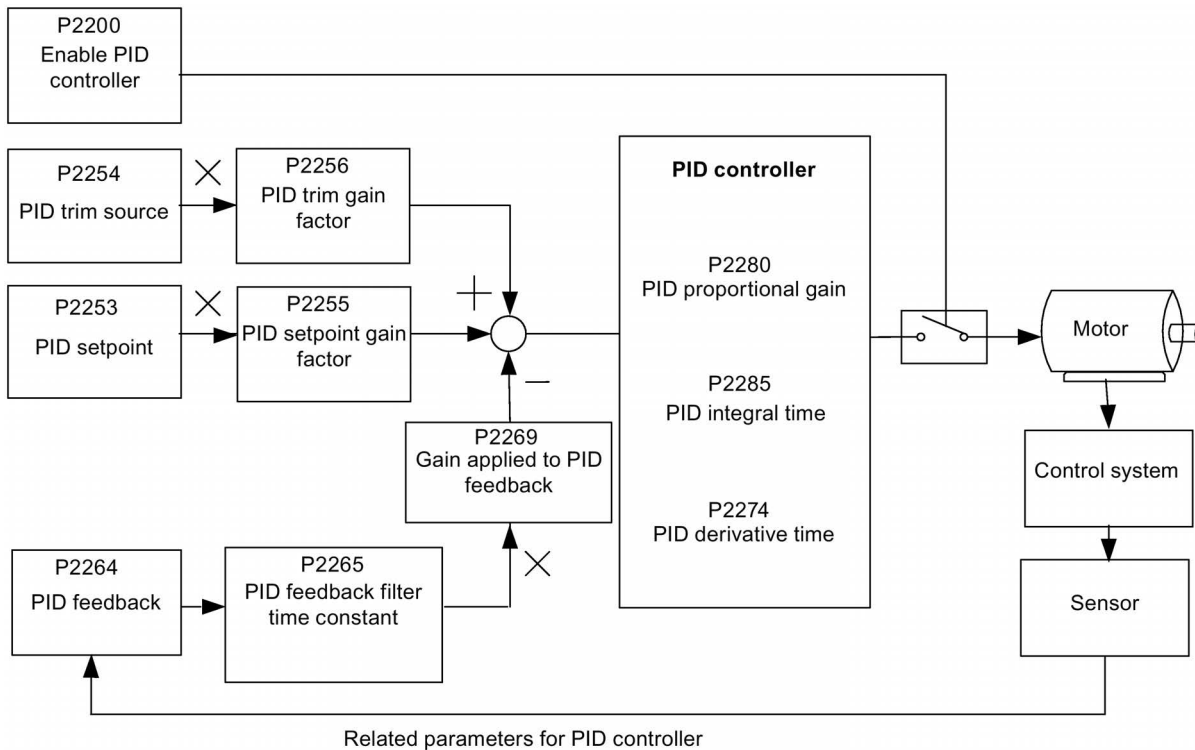

#### Setting parameters

Parameter	Function	Setting
<b>Main function parameters</b>		
P2200[0...2]	BI: Enable PID controller	This parameter allows user to enable / disable the PID controller. Setting to 1 enables the PID closed-loop controller. Setting 1 automatically disables normal ramp times set in P1120 and P1121 and the normal frequency setpoints. Factory default: 0
P2235[0...2]	BI: Enable PID-MOP (UP-cmd)	This parameter defines source of UP command. Possible sources: 19.13 (BOP), 722.x (Digital Input), 2036.13 (USS on RS485)
P2236[0...2]	BI: Enable PID-MOP (DOWN-cmd)	This parameter defines source of DOWN command. Possible sources: 19.14 (BOP), 722.x (Digital Input), 2036.14 (USS on RS485)
<b>Additional commissioning parameters</b>		
P2251	PID mode	= 0: PID as setpoint (factory default) = 1: PID as trim source

Parameter	Function	Setting
P2253[0...2]	CI: PID setpoint	This parameter defines setpoint source for PID setpoint input. Possible sources: 755[0] (Analog input 1), 2018.1 (USS PZD 2), 2224 (Actual fixed PID setpoint), 2250 (Output setpoint of PID-MOP)
P2254[0...2]	CI: PID trim source	This parameter selects trim source for PID setpoint. Possible sources: 755[0] (Analog input 1), 2018.1 (USS PZD 2), 2224 (Actual fixed PID setpoint), 2250 (Output setpoint of PID-MOP)
P2255	PID setpoint gain factor	Range: 0.00 to 100.00 (factory default: 100.00)
P2256	PID trim gain factor	Range: 0.00 to 100.00 (factory default: 100.00)
P2257	Ramp-up time for PID setpoint [s]	Range: 0.00 to 650.00 (factory default: 1.00)
P2258	Ramp-down time for PID setpoint [s]	Range: 0.00 to 650.00 (factory default: 1.00)
P2263	PID controller type	= 0: D component on feedback signal (factory default) = 1: D component on error signal
P2264[0...2]	CI: PID feedback	Possible sources: 755[0] (Analog input 1), 2224 (Actual fixed PID setpoint), 2250 (Output setpoint of PID-MOP) Factory default: 755[0]
P2265	PID feedback filter time constant [s]	Range: 0.00 to 60.00 (factory default: 0.00)
P2267	Maximum value for PID feedback [%]	Range: -200.00 to 200.00 (factory default: 100.00)
P2268	Minimum value for PID feedback [%]	Range: -200.00 to 200.00 (factory default: 0.00)
P2269	Gain applied to PID feedback	Range: 0.00 to 500.00 (factory default: 100.00)
P2270	PID feedback function selector	= 0: Disabled (factory default) = 1: Square root (root(x)) = 2: Square (x*x) = 3: Cube (x*x*x)
P2271	PID transducer type	= 0 : Disabled (factory default) = 1: Inversion of PID feedback signal
P2274	PID derivative time [s]	Range: 0.000 to 60.000 Factory default: 0.000 (the derivative time does not have any effect)
P2280	PID proportional gain	Range: 0.000 to 65.000 (factory default: 3.000)
P2285	PID integral time [s]	Range: 0.000 to 60.000 (factory default: 0.000)
P2291	PID output upper limit [%]	Range: -200.00 to 200.00 (factory default: 100.00)
P2292	PID output lower limit [%]	Range: -200.00 to 200.00 (factory default: 0.00)
P2293	Ramp-up / -down time of PID limit [s]	Range: 0.00 to 100.00 (factory default: 1.00)
P2295	Gain applied to PID output	Range: -100.00 to 100.00 (factory default: 100.00)
P2350	PID autotune enable	= 0: PID autotuning disabled (factory default) = 1: PID autotuning via Ziegler Nichols (ZN) standard = 2: PID autotuning as 1 plus some overshoot (O/S) = 3: PID autotuning as 2 little or no overshoot (O/S) = 4: PID autotuning PI only, quarter damped response
P2354	PID tuning timeout length [s]	Range: 60 to 65000 (factory default: 240)
P2355	PID tuning offset [%]	Range: 0.00 to 20.00 (factory default: 5.00)
Output values		
r2224	CO: Actual fixed PID setpoint [%]	
r2225.0	BO: PID fixed frequency status	
r2245	CO: PID-MOP input frequency of the RFG [%]	
r2250	CO: Output setpoint of PID-MOP [%]	
r2260	CO: PID setpoint after PID-RFG [%]	
P2261	PID setpoint filter time constant [s]	

Parameter	Function	Setting
r2262	CO: Filtered PID setpoint after RFG [%]	
r2266	CO: PID filtered feedback [%]	
r2272	CO: PID scaled feedback [%]	
r2273	CO: PID error [%]	
r2294	CO: Actual PID output [%]	

### 5.6.2.5 Setting the braking function

#### Functionality

The motor can be electrically or mechanically braked by the inverter via the following brakes:

- Electrical brakes
  - DC brake
  - Compound brake
  - Dynamic brake
- Mechanical brake
  - Motor holding brake

#### DC braking

DC braking causes the motor to stop rapidly by applying a DC braking current (current applied also holds shaft stationary). For DC braking, a DC current is impressed in the stator winding which results in a significant braking torque for an asynchronous motor.

DC braking is selected as follows:

- Sequence 1: selected after OFF1 or OFF3 (the DC brake is released via P1233)
- Sequence 2: selected directly with the BICO parameter P1230

#### Sequence 1

1. Enabled using P1233
2. DC braking is activated with the OFF1 or OFF3 command (see figure below)
3. The inverter frequency is ramped down along the parameterized OFF1 or OFF3 ramp down to the frequency at which DC braking is to start - P1234.
4. The inverter pulses are inhibited for the duration of the de-magnetizing time P0347.
5. The required braking current P1232 is then impressed for the selected braking time P1233. The status is displayed using signal r0053 bit 00.

The inverter pulses are inhibited after the braking time has expired.

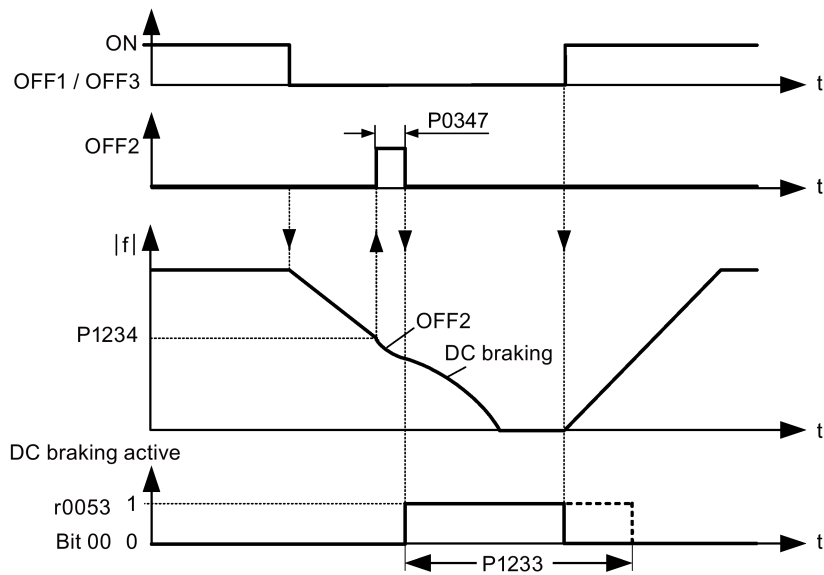

Sequence 2

1. Enabled and selected with the BICO parameter P1230 (see figure below).
2. The inverter pulses are inhibited for the duration of the de-magnetizing time P0347.
3. The requested braking current P1232 is impressed for the time selected and the motor is braked. This state is displayed using signal r0053 bit 00.
4. After DC braking has been cancelled, the inverter accelerates back to the setpoint frequency until the motor speed matches the inverter output frequency.

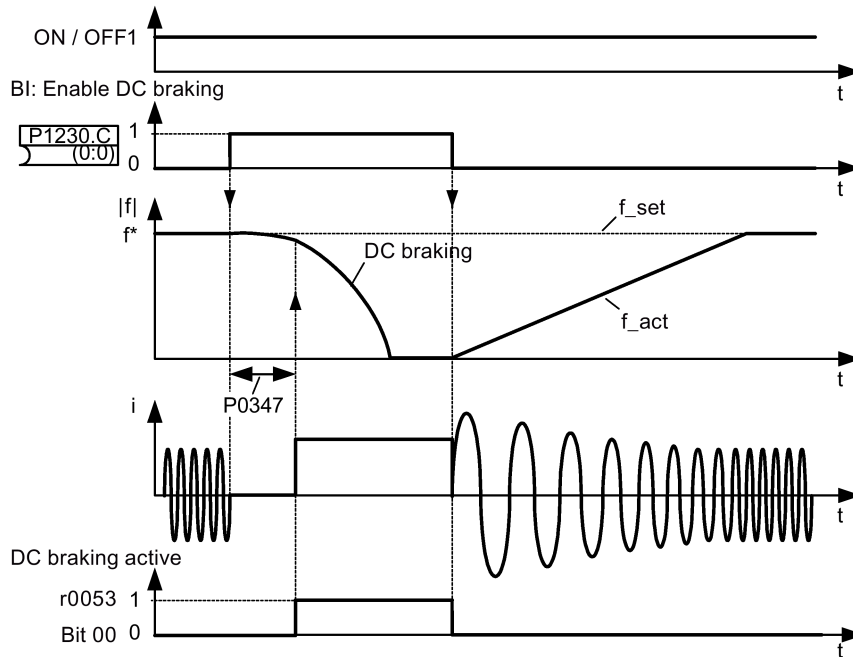



## Setting parameters

Parameter	Function	Setting
P1230[0...2]	BI: Enable DC braking	This parameter enables DC braking via a signal applied from an external source. The function remains active while external input signal is active. Factory default: 0
P1232[0...2]	DC braking current [%]	This parameter defines level of DC current relative to rated motor current (P0305). Range: 0 to 250 (factory default: 100)
P1233[0...2]	Duration of DC braking [s]	This parameter defines duration for which DC braking is active following an OFF1 or OFF3 command. Range: 0.00 to 250.00 (factory default: 0.00)
P1234[0...2]	DC braking start frequency [Hz]	This parameter sets the start frequency for DC braking. Range: 0.00 to 550.00 (factory default: 550.00)
P0347[0...2]	Demagnetization time [s]	This parameter changes time allowed after OFF2 / fault condition, before pulses can be re-enabled. Range: 0.000 to 20.000 (factory default: 1.000)

 **WARNING**

**Motor overheat**

For DC current braking, the motor kinetic energy is converted into thermal energy in the motor. If braking lasts too long, then the motor can overheat.

**Note**

The "DC braking" function is only practical for induction motors.

DC braking is not suitable to hold suspended loads.

While DC braking, there is no other way of influencing the inverter speed using an external control. When parameterizing and setting the inverter system, it should be tested using real loads as far as possible.

### Compound braking

For compound braking (enabled using P1236), DC braking is superimposed with regenerative braking (where the inverter regenerates into the DC-link supply as it brakes along a ramp). Effective braking is obtained without having to use additional components by optimizing the ramp-down time (P1121 for OFF1 or when braking from f1 to f2, P1135 for OFF3) and using compound braking P1236.

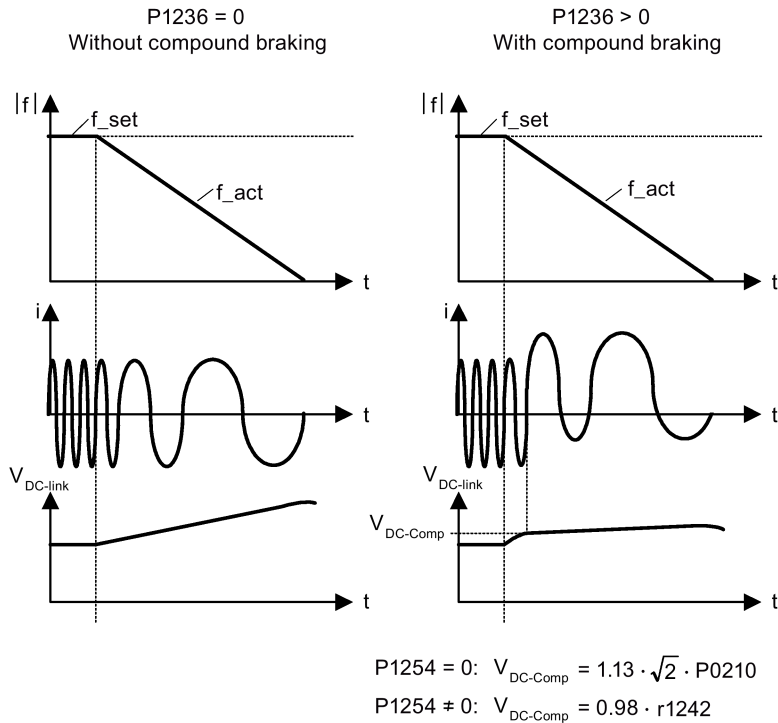

### Setting parameters

Parameter	Function	Setting
P1236[0...2]	Compound braking current [%]	This parameter defines DC level superimposed on AC waveform after exceeding DC-link voltage threshold of compound braking. The value is entered in [%] relative to rated motor current (P0305). Range: 0 to 250 (factory default: 0)
P1254	Auto detect Vdc switch-on levels	This parameter enables / disables auto-detection of switch-on levels for Vdc_max controller. = 0: Disabled = 1: Enabled (factory default) It is recommended to set P1254 = 1 (auto detection of Vdc switch-on levels enabled). Note that auto detection only works when the inverter has been in standby for over 20s.

**⚠ WARNING**

**Motor overheat**

For compound braking, regenerative braking is superimposed on the DC braking (braking along a ramp). This means that components of the kinetic energy of the motor and motor load are converted into thermal energy in the motor. This can cause the motor to overheat if this power loss is too high or if the brake operation takes too long!

**Note**

The compound braking depends on the DC link voltage only (see threshold in the above diagram). This will happen on OFF1, OFF3 and any regenerative condition. Compound braking is deactivated, if:

- flying start is active
- DC braking is active.

## Dynamic braking

Dynamic braking converts the regenerative energy, which is released when the motor decelerates, into heat. An internal braking chopper or an external dynamic braking module, which can control an external braking resistor, is required for dynamic braking. The inverter or the external dynamic braking module controls the dynamic braking depending on the DC link voltage. Contrary to DC and compound braking, this technique requires that an external braking resistor is installed.

Frame size A / B / C

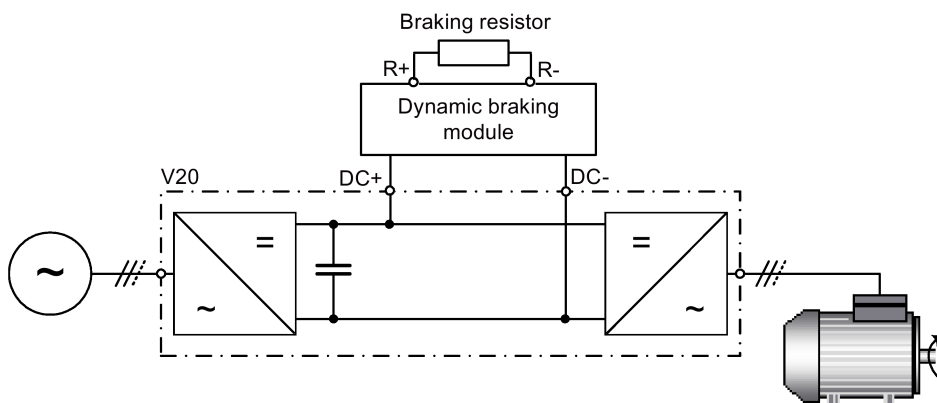

For more information about the dynamic braking module, refer to the Appendix "Dynamic braking module (Page 312)".

Frame size D

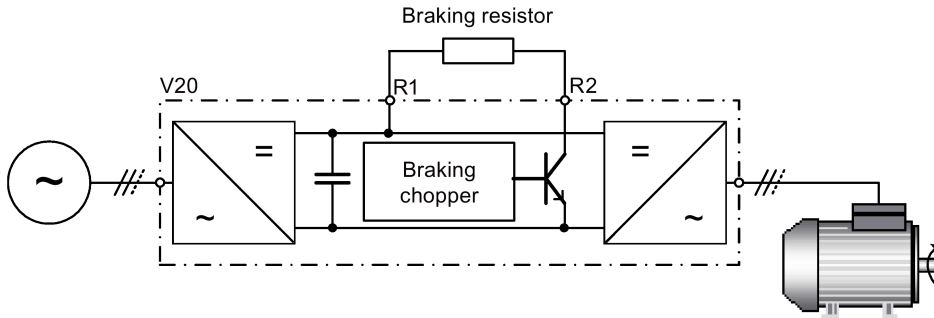

The continuous power  $P_{DB}$  and the duty cycle for the braking resistor can be modified using the dynamic braking module (for frame size A / B / C) or parameter P1237 (for frame size D).

<b>NOTICE</b>
<b>Damage to the braking resistor</b>
The average power of the dynamic braking module (braking chopper) cannot exceed the power rating of the braking resistor.

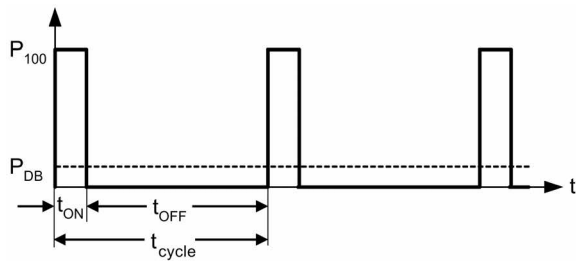

Dynamic braking switch-on level:

$$P1254 = 0: V_{DC-Chopper} = 1.13 \cdot \sqrt{2} \cdot P0210$$

$$P1254 \neq 0: V_{DC-Chopper} = 0.98 \cdot r1242$$

Duty cycle	t <sub>ON</sub> (s)	t <sub>OFF</sub> (s)	t <sub>cycle</sub> (s)	P <sub>DB</sub>
5%	12.0	228.0	240.0	0.05
10%	12.6	114.0	126.6	0.10
20%	14.2	57.0	71.2	0.20
50%	22.8	22.8	45.6	0.50
100%	Infinite	0	Infinite	1.00

## Setting parameters

Parameter	Function	Setting
P1237	Dynamic braking	<p>This parameter defines the rated duty cycle of the braking resistor (chopper resistor). Dynamic braking is active when the function is enabled and DC-link voltage exceeds the dynamic braking switch-on level.</p> <p>= 0: Disabled (factory default)            = 1: 5% duty cycle            = 2: 10% duty cycle            = 3: 20% duty cycle            = 4: 50% duty cycle            = 5: 100% duty cycle</p> <p><b>Note:</b> This parameter is only applicable for inverters of frame size D. For frame sizes A to C, the duty cycle of the braking resistor can be selected with the dynamic braking module.</p>
P1240[0...2]	Configuration of Vdc controller	<p>This parameter enables / disables Vdc controller.</p> <p>= 0: Vdc controller disabled</p> <p><b>Note:</b> This parameter must be set to 0 (Vdc controller disabled) to activate the dynamic braking.</p>
P1254	Auto detect Vdc switch-on levels	<p>This parameter enables / disables auto-detection of switch-on levels for Vdc_max controller.</p> <p>= 0: Disabled            = 1: Enabled (factory default)</p> <p>It is recommended to set P1254 = 1 (auto detection of Vdc switch-on levels enabled). Note that auto detection only works when the inverter has been in standby for over 20s. When P1240 = 0, P1254 is only applicable for frame size D inverters.</p>

 **WARNING**
**Risks with the use of inappropriate braking resistors**

Braking resistors, which are to be mounted on the inverter, must be designed so that they can tolerate the power dissipated. If an unsuitable braking resistor is used, there is a danger of fire and the associated inverter will be significantly damaged.

### Motor holding brake

The motor holding brake prevents the motor from undesirable turning when the inverter is switched-off. The inverter has internal logic to control a motor holding brake.

ON / OFF1 / OFF3:

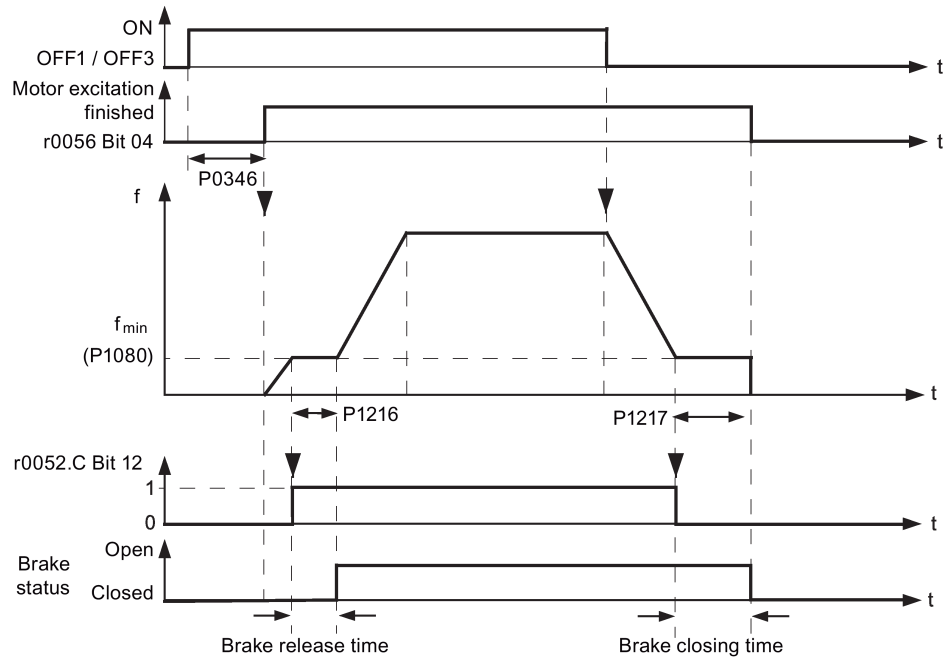

ON / OFF2:

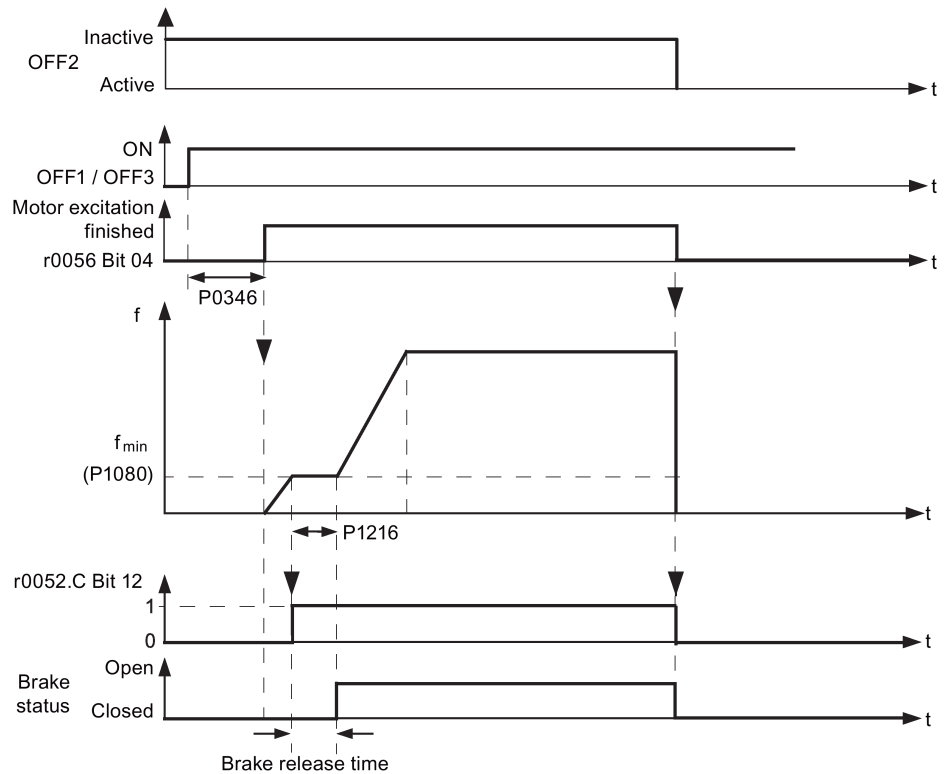

## Setting parameters

Parameter	Function	Setting
P1215	Holding brake enable	This parameter enables / disables holding brake function. The motor holding brake (MHB) is controlled via status word 1 r0052 bit 12. = 0: Motor holding brake disabled (factory default) = 1: Motor holding brake enabled
P1216	Holding brake release delay[s]	This parameter defines period during which inverter runs at minimum frequency P1080 before ramping up. Range: 0.0 to 20.0 (factory default: 1.0)
P1217	Holding time after ramp down [s]	This parameter defines time for which inverter runs at minimum frequency (P1080) after ramping down. Range: 0.0 to 20.0 (factory default: 1.0)

## Connecting the motor holding brake

The motor holding brake can be connected to the inverter via digital outputs (DO1/DO2). An additional relay is also required to allow the digital output to enable or disable the motor holding brake.

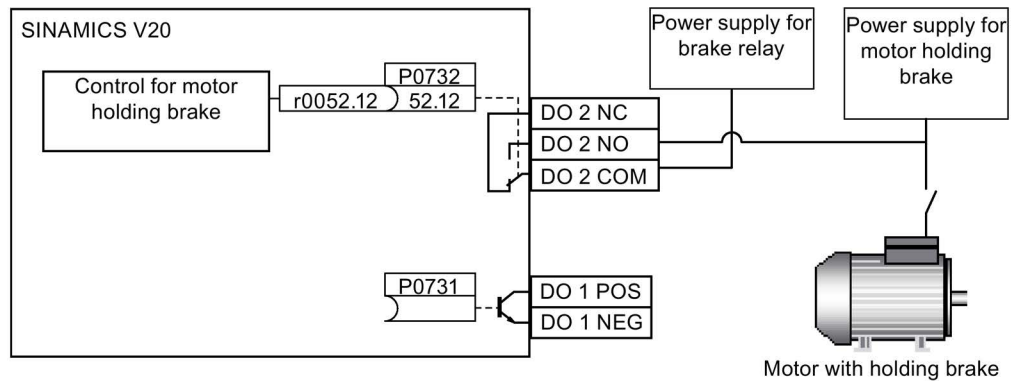

### **WARNING**

#### Potentially hazardous load

If the inverter controls the motor holding brake, then a commissioning may not be carried out for potentially hazardous loads (e.g. suspended loads for crane applications) unless the load has been secured.

It is not permissible to use the motor holding brake as operating brake. The reason for this is that generally it is only designed for a limited number of emergency braking operations.

### 5.6.2.6 Setting the ramp time

#### Functionality

The ramp-function generator in the setpoint channel limits the speed of setpoint changes. This causes the motor to accelerate and decelerate more smoothly, thereby protecting the mechanical components of the driven machine.

#### Setting ramp-up / down time

The ramp-up and ramp-down times can be set independently of each other by P1120 and P1121.

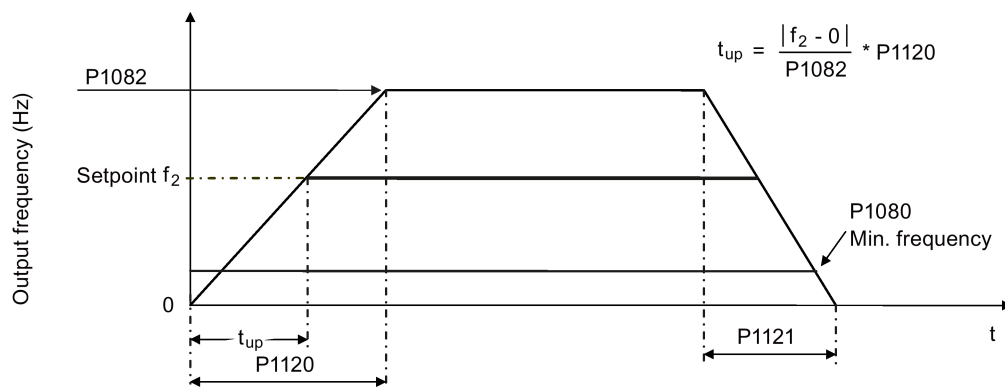

#### Setting parameters

Parameter	Function	Setting
P1082[0...2]	Maximum frequency [Hz]	This parameter sets maximum motor frequency at which motor will run irrespective of the frequency setpoint. Range: 0.00 to 550.00 (factory default: 50.00)
P1120[0...2]	Ramp-up time [s]	This parameter sets the time taken for motor to accelerate from standstill up to maximum motor frequency (P1082) when no rounding is used. Range: 0.00 to 650.00 (factory default: 10.00)
P1121[0...2]	Ramp-down time [s]	This parameter sets the time taken for motor to decelerate from maximum motor frequency (P1082) down to standstill when no rounding is used. Range: 0.00 to 650.00 (factory default: 10.00)



### Setting ramp-up / down rounding time

Rounding times are recommended, since they prevent an abrupt response, thus avoiding detrimental effects on the mechanics.

Rounding times are not recommended when analog inputs are used, since they would result in overshoot / undershoot in the inverter response.

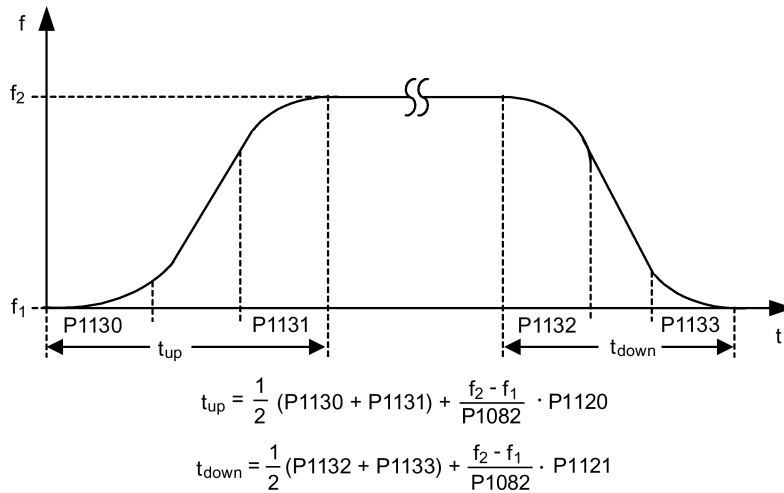

### Setting parameters

Parameter	Function	Setting
P1130[0...2]	Ramp-up initial rounding time [s]	This parameter defines rounding time at start of ramp-up. Range: 0.00 to 40.00 (factory default: 0.00)
P1131[0...2]	Ramp-up final rounding time [s]	This parameter defines rounding time at end of ramp-up. Range: 0.00 to 40.00 (factory default: 0.00)
P1132[0...2]	Ramp-down initial rounding time [s]	This parameter defines rounding time at start of ramp-down. Range: 0.00 to 40.00 (factory default: 0.00)
P1133[0...2]	Ramp-down final rounding time [s]	This parameter defines rounding time at end of ramp-down. Range: 0.00 to 40.00 (factory default: 0.00)

### 5.6.2.7 Setting the I<sub>max</sub> controller

#### Functionality

If ramp-up time is too short, the inverter may display the alarm A501 which means the output current is too high. The I<sub>max</sub> controller reduces inverter current if the output current exceeds the maximum output current limit (r0067). This is achieved by reducing the inverter's output frequency or output voltage.

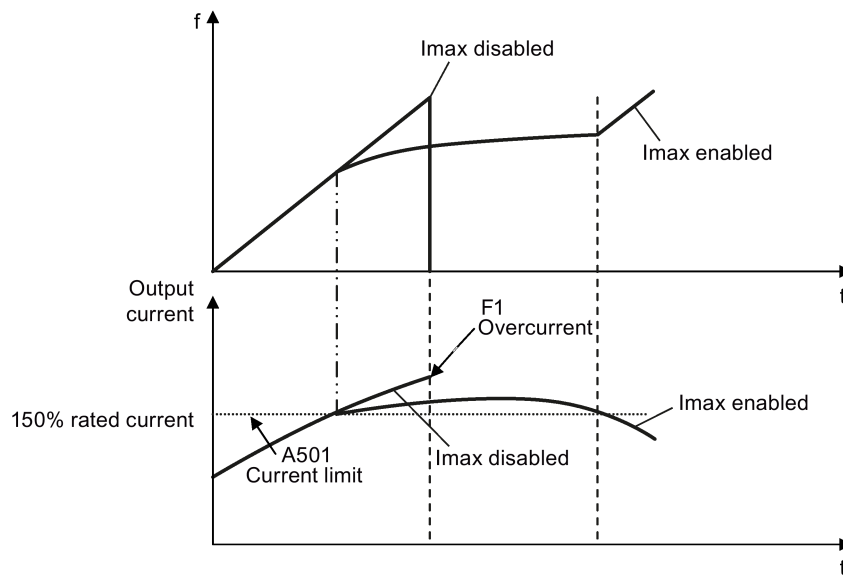
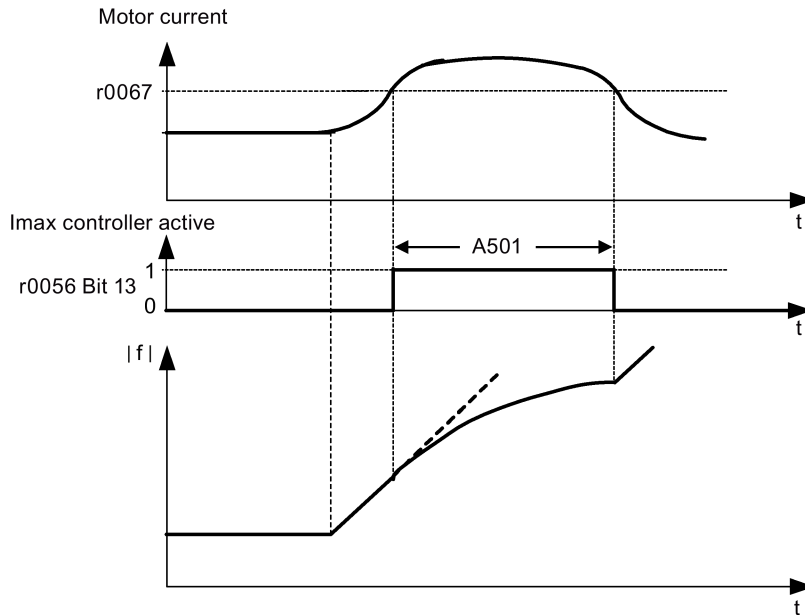

## Setting parameters

You only have to change the factory default settings of the I<sub>max</sub> controller if the inverter tends to oscillate when it reaches the current limit or it is shut down due to overcurrent.

Parameter	Function	Setting
P0305[0...2]	Rated motor current [A]	This parameter defines the nominal motor current from rating plate.
P0640[0...2]	Motor overload factor [%]	This parameter defines motor overload current limit relative to P0305 (rated motor current).
P1340[0...2]	I <sub>max</sub> controller proportional gain	This parameter defines the proportional gain of the I <sub>max</sub> controller. Range: 0.000 to 0.499 (factory default: 0.030)
P1341[0...2]	I <sub>max</sub> controller integral time [s]	This parameter defines the integral time constant of the I <sub>max</sub> controller. Setting P1341 to 0 disables the I <sub>max</sub> controller. Range: 0.000 to 50.000 (factory default: 0.300)
P1345[0...2]	I <sub>max</sub> voltage controller proportional gain	This parameter sets the proportional gain of I <sub>max</sub> voltage controller. If the output current (r0068) exceeds the maximum current (r0067), the inverter is dynamically controlled by reducing the output voltage. Range: 0.000 to 5.499 (factory default: 0.250)
P1346[0...2]	I <sub>max</sub> voltage controller integral time [s]	This parameter defines the integral time constant of the I <sub>max</sub> voltage controller. Range: 0.000 to 50.000 (factory default: 0.300)
r0056.13	Status of motor control: I <sub>max</sub> controller active	

### 5.6.2.8 Setting the Vdc controller

#### Functionality

If ramp-down time is too short, the inverter may display the alarm A911 which means the DC link voltage is too high. The Vdc controller dynamically controls the DC link voltage to prevent overvoltage trips on high inertia systems.

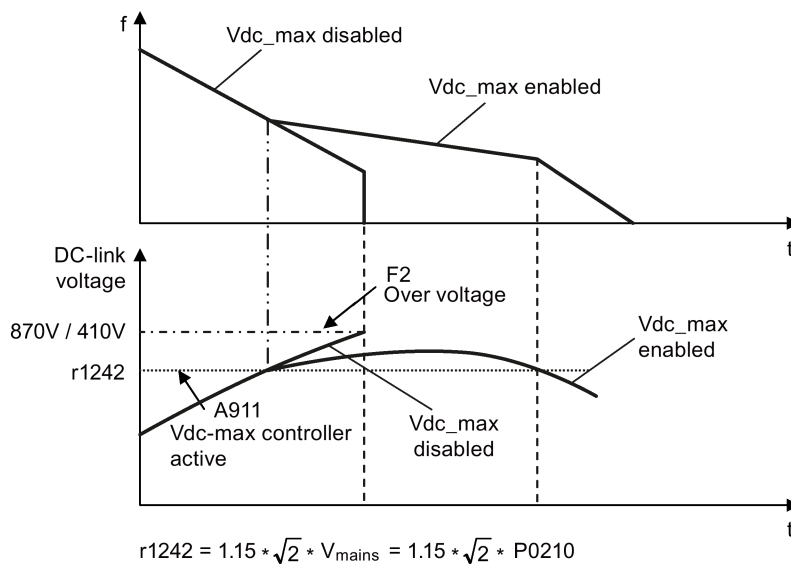
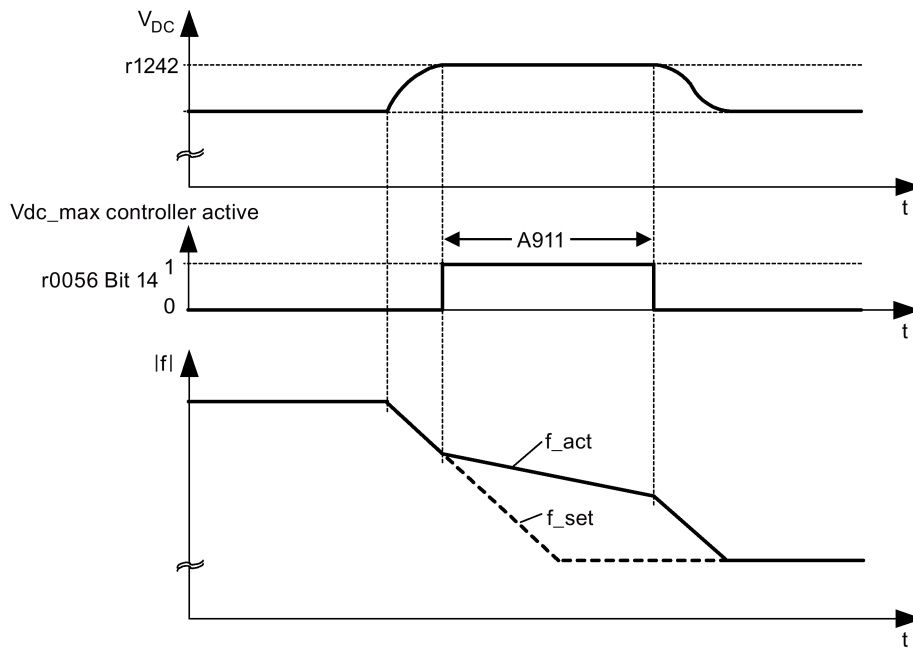

## Setting parameters

Parameter	Function	Setting
P1240[0...2]	Configuration of Vdc controller	This parameter enables / disables Vdc controller. = 0: Vdc controller disabled = 1: Vdc_max controller enabled (factory default) = 2: Kinetic buffering (Vdc_min controller) enabled = 3: Vdc_max controller and kinetic buffering (KIB) enabled <b>Note:</b> This parameter must be set to 0 (Vdc controller disabled) if a braking resistor is used.
P0210	Supply voltage [V]	This parameter defines the supply voltage. Its default value depends upon the type of inverter. Range: 380 to 480

### 5.6.2.9 Setting the load torque monitoring function

#### Functionality

The load torque monitoring function allows the mechanical force transmission between the motor and driven load to be monitored. This function can detect whether the driven load is blocked, or the force transmission has been interrupted.

The inverter monitors the load torque of the motor in different ways:

- Motor blocking detection
- No-load monitoring
- Speed-dependent load torque monitoring

#### Setting parameters

Parameter	Function	Setting
P2177[0...2]	Delay time for motor is blocked [ms]	Defines the delay time for identifying that the motor is blocked. Range: 0 to 10000 (factory default: 10)
P2179	Current limit for no load identified [%]	This parameter defines the threshold current for A922 (no load applied to inverter) relative to P0305 (rated motor current). Range: 0.0 to 10.0 (factory default: 3.0)
P2180	Delay time for no-load identification [ms]	Defines the delay time for detecting a missing output load. Range: 0 to 10000 (factory default: 2000)

Parameter	Function	Setting
P2181[0...2]	Load monitoring mode	The load monitoring is achieved by comparing the actual frequency / torque curve with a programmed envelope (defined by parameters P2182 to P2190). If the curve falls outside the envelope, a warning or trip is generated. = 0: Load monitoring disabled (factory default) = 1: Warning: Low torque / frequency = 2: Warning: High torque / frequency = 3: Warning: High / low torque / frequency = 4: Trip: Low torque / frequency = 5: Trip: High torque / frequency = 6: Trip: High / low torque / frequency
P2182[0...2]	Load monitoring threshold frequency 1 [Hz]	Range: 0.00 to 550.00 (factory default: 5.00)
P2183[0...2]	Load monitoring threshold frequency 2 [Hz]	Range: 0.00 to 550.00 (factory default: 30.00)
P2184[0...2]	Load monitoring threshold frequency 3 [Hz]	Range: 0.00 to 550.00 (factory default: 30.00)
P2185[0...2]	Upper torque threshold 1 [Nm]	Range: 0.0 to 99999.0 (factory default: value in r0333)
P2186[0...2]	Lower torque threshold 1 [Nm]	Range: 0.0 to 99999.0 (factory default: 0.0)
P2187[0...2]	Upper torque threshold 2 [Nm]	Range: 0.0 to 99999.0 (factory default: value in r0333)
P2188[0...2]	Lower torque threshold 2 [Nm]	Range: 0.0 to 99999.0 (factory default: 0.0)
P2189[0...2]	Upper torque threshold 3 [Nm]	Range: 0.0 to 99999.0 (factory default: value in r0333)
P2190[0...2]	Lower torque threshold 3 [Nm]	Range: 0.0 to 99999.0 (factory default: 0.0)
P2192[0...2]	Load monitoring delay time [s]	Range: 0 to 65 (factory default: 10)

## 5.6.3 Commissioning advanced functions

### 5.6.3.1 Starting the motor in super torque mode

#### Functionality

This startup mode applies a torque pulse for a given time to help start the motor.

#### Typical application field

Sticky pumps

#### Setting parameters

Parameter	Function	Setting
P3350[0...2]	Super torque modes	= 1: Enable super torque mode <b>Note:</b> When the value of P3350 is changed, the value of P3353 is changed as follows: <ul style="list-style-type: none"> <li>• P3350 = 2: P3353 = 0.0s</li> <li>• P3350 ≠ 2: P3353 = default</li> </ul> The ramp time of 0s gives an additional 'kicking' effect when hammer start is in use.
P3351[0...2]	BI: Super torque enable	This parameter defines the source of the super torque enable. The setting is effective when P3352 = 2. Factory default: 0 (never enabled)
P3352[0...2]	Super torque startup mode	This parameter defines when the super torque function becomes active. = 0: Enabled on first run after power-up = 1: Enabled on every run = 2: Enabled by digital input (enable source is defined by P3351; 0 = never enabled, 1 = enabled on every run)
P3353[0...2]	Super torque ramp time [s]	This parameter defines the ramp time to be used when ramping up to the super torque frequency. Range: 0.0 to 650.0 (factory default: 5.0)
P3354[0...2]	Super torque frequency [Hz]	This parameter defines the frequency at which the additional boost is applied for super torque mode. Range: 0.0 to 550.0 (factory default: 5.0)
P3355[0...2]	Super torque boost level [%]	This parameter sets the temporary boost level for super torque mode. It applies boost in [%] relative to P0305 (rated motor current) once the super torque frequency has been reached for the time specified in P3356. Range: 0.0 to 200.0 (factory default: 150.0)
P3356[0...2]	Super torque boost time [s]	This parameter sets the time for which the additional boost is applied, when the output frequency is held at P3354. Range: 0.0 to 20.0 (factory default: 5.0)

### Function diagram

Description:

The Super Torque mode is enabled when an ON command is issued, and the following sequence is performed:

- Ramps up to P3354 Hz with the boost level specified by P1310, P1311, and P1312
- Maintains for P3356 s with the boost level specified by P3355
- Reverts boost level to that specified by P1310, P1311, and P1312
- Reverts to "normal" setpoint and allows output to ramp using P1120

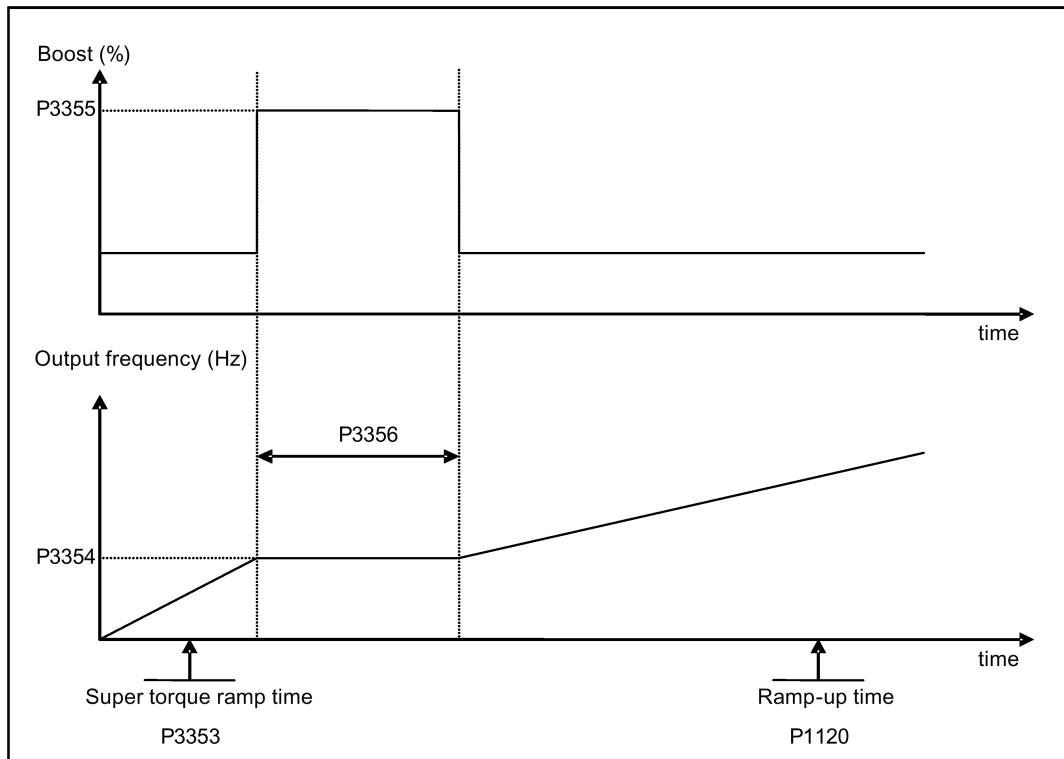



### 5.6.3.2 Starting the motor in hammer start mode

#### Functionality

This startup mode applies a sequence of torque pulses to start the motor.

#### Typical application field

Very sticky pumps

#### Setting parameters

Parameter	Function	Setting
P3350[0...2]	Super torque modes	= 2: Enable hammer start mode <b>Note:</b> When the value of P3350 is changed, the value of P3353 is changed as follows: <ul style="list-style-type: none"> <li>• P3350 = 2: P3353 = 0.0s</li> <li>• P3350 ≠ 2: P3353 = default</li> </ul> The ramp time of 0s gives an additional 'kicking' effect when hammer start is in use.
P3351[0...2]	BI: Super torque enable	This parameter defines the source of the super torque enable. The setting is effective when P3352 = 2. Factory default: 0 (never enabled)
P3352[0...2]	Super torque startup mode	This parameter defines when the super torque function becomes active. <ul style="list-style-type: none"> <li>= 0: Enabled on first run after power-up</li> <li>= 1: Enabled on every run</li> <li>= 2: Enabled by digital input (enable source is defined by P3351; 0 = never enabled, 1 = enabled on every run)</li> </ul>
P3353[0...2]	Super torque ramp time [s]	This parameter defines the ramp time to be used when ramping up to the super torque frequency. Range: 0.0 to 650.0 (factory default: 5.0)
P3354[0...2]	Super torque frequency [Hz]	This parameter defines the frequency at which the additional boost is applied for super torque mode. Range: 0.0 to 550.0 (factory default: 5.0)
P3357[0...2]	Hammer start boost level [%]	This parameter sets the temporary boost level for hammer start mode. It applies boost in [%] relative to P0305 (rated motor current) once the super torque frequency has been reached for the time specified in P3356. Range: 0.0 to 200.0 (factory default: 150.0)
P3358[0...2]	Number of hammer cycles	This parameter defines the number of times the hammer start boost level is applied. Range: 1 to 10 (factory default: 5)

Parameter	Function	Setting
P3359[0...2]	Hammer on time [ms]	This parameter sets the time for which the additional boost is applied for each repetition (must be at least 3 x motor magnetization time). Range: 0 to 1000 (factory default: 300)
P3360[0...2]	Hammer off Time [ms]	This parameter sets the time for which the additional boost is removed for each repetition (must be at least 3 x motor magnetization time). Range: 0 to 1000 (factory default: 100)

**Function diagram**

Description:

The hammer start mode is enabled when an ON command is issued, and the following sequence is performed:

- Ramp up to P3354 Hz with the boost level specified by P1310, P1311, and P1312
- Revert boost level to that specified by P1310, P1311, and P1312
- Revert to "normal" setpoint and allow output to ramp using P1120

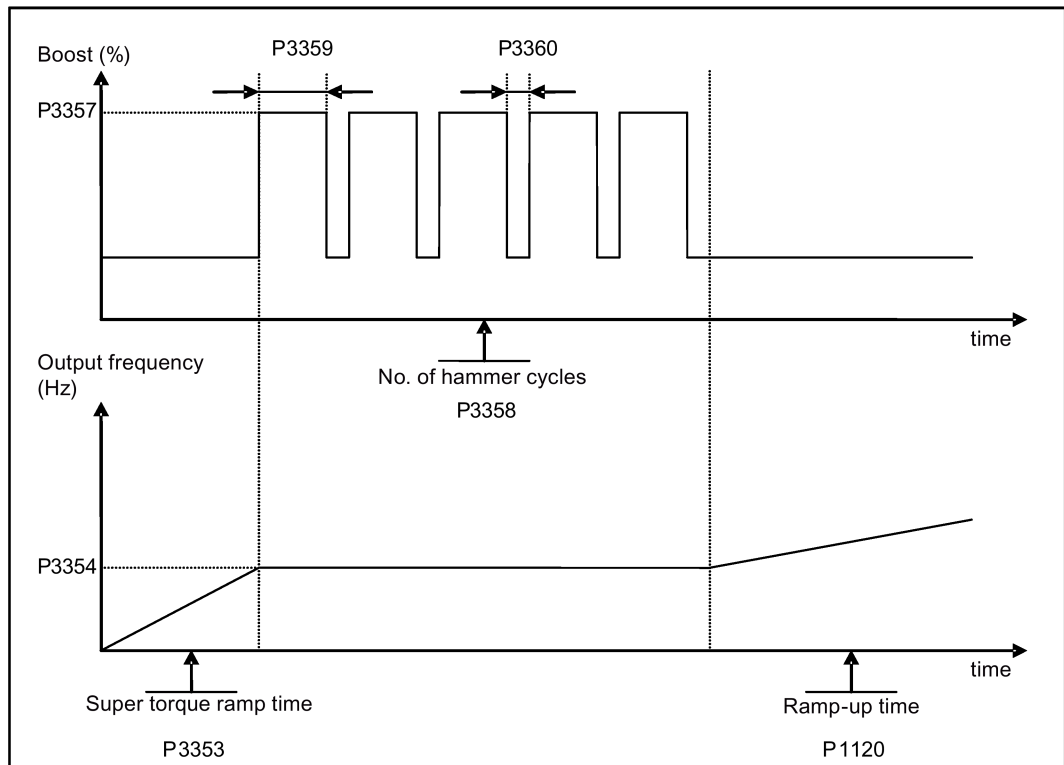

### 5.6.3.3 Starting the motor in blockage clearing mode

#### Functionality

This startup mode momentarily reverses the motor rotation to clear a pump blockage.

#### Typical application field

Pump clearing

#### Setting parameters

Parameter	Function	Setting
P3350[0...2]	Super torque modes	<p>= 3: Enable blockage clearing mode</p> <p><b>Note:</b> When the value of P3350 is changed, the value of P3353 is changed as follows:</p> <ul style="list-style-type: none"> <li>• P3350 = 2: P3353 = 0.0s</li> <li>• P3350 ≠ 2: P3353 = default</li> </ul> <p>The ramp time of 0s gives an additional 'kicking' effect when hammer start is in use.</p> <p>If blockage clearing mode is enabled (P3350 = 3), make sure that reverse direction is not inhibited, i.e. P1032 = P1110 = 0.</p>
P3351[0...2]	BI: Super torque enable	<p>This parameter defines the source of the super torque enable. The setting is effective when P3352 = 2.</p> <p>Factory default: 0 (never enabled)</p>
P3352[0...2]	Super torque startup mode	<p>This parameter defines when the super torque function becomes active.</p> <p>= 0: Enabled on first run after power-up</p> <p>= 1: Enabled on every run</p> <p>= 2: Enabled by digital input (enable source is defined by P3351; 0 = never enabled, 1 = enabled on every run)</p>
P3353[0...2]	Super torque ramp time [s]	<p>This parameter defines the ramp time to be used when ramping up to the super torque frequency.</p> <p>Range: 0.0 to 650.0 (factory default: 5.0)</p>
P3361[0...2]	Blockage clearing frequency [Hz]	<p>This parameter defines the frequency at which the inverter runs in the opposite direction to the setpoint during the blockage clearing reverse sequence.</p> <p>Range: 0.0 to 550.0 (factory default: 5.0)</p>
P3362[0...2]	Blockage clearing reverse time [s]	<p>This parameter sets the time for which the inverter runs in the opposite direction to the setpoint during the reverse sequence.</p> <p>Range: 0.0 to 20.0 (factory default: 5.0)</p>

Parameter	Function	Setting
P3363[0...2]	Enable rapid ramp	This parameter selects whether the inverter ramps to, or starts directly from, the blockage clearing frequency = 0: Disable rapid ramp for blockage clearing (use ramp time specified in P3353) = 1: Enable rapid ramp for blockage clearing (jump to the reverse frequency - this introduces a "kicking" effect which helps to clear the blockage) Range: 0 to 1 (factory default: 0)
P3364[0...2]	Number of blockage clearing cycles	This parameter sets the number of times the blockage clearing reversing cycle is repeated. Range: 1 to 10 (factory default: 1)

**Function diagram**

Description:

The blockage clearing mode is enabled when an ON command is issued, and the following sequence is performed:

- Ramp or step (depending on P3363) to P3361 Hz in opposite direction to the setpoint
- For P3364 repetitions:
  - Ramp down to 0 Hz using normal ramp time as specified in P1121
  - Ramp or step (depending on P3363) to P3361 Hz in opposite direction to the setpoint
- Revert to "normal" setpoint and allow output to ramp using P1120.

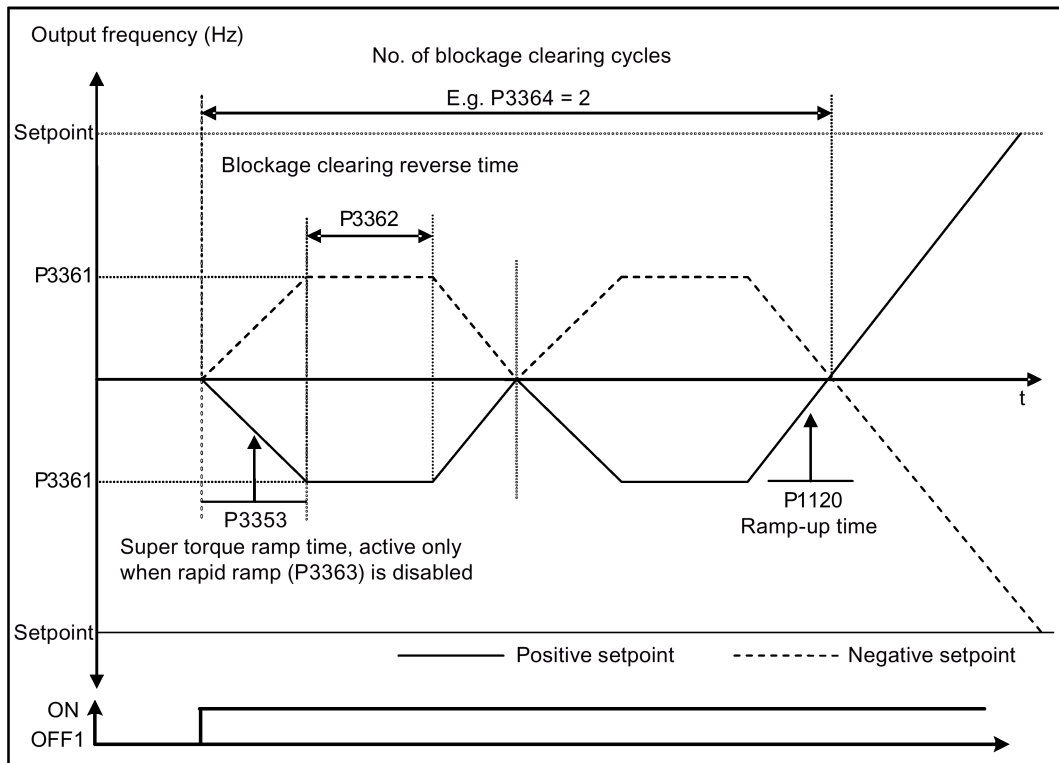

### 5.6.3.4 Running the inverter in economy mode

#### Functionality

Economy mode works by slightly changing the output voltage either up or down in order to find the minimum input power.

---

#### Note

The economy mode optimization is only active when operating at the requested frequency setpoint. The optimization algorithm becomes active 5 seconds after the setpoint has been reached, and is disabled on a setpoint change or if the  $I_{\max}$  or  $V_{\max}$  controller is active.

---

#### Typical applications

Motors with stable or slowly changing loads

#### Setting parameters

Parameter	Function	Setting
P1300[0...2]	Control mode	= 4: V/f Eco Mode with linear characteristic = 7: V/f Eco Mode with quadratic characteristic
r1348	Economy mode factor [%]	This parameter displays the calculated economy mode factor (range: 80% to 120%) applied to the demanded output voltage. If this value is too low, the system may become unstable.

#### Function diagram

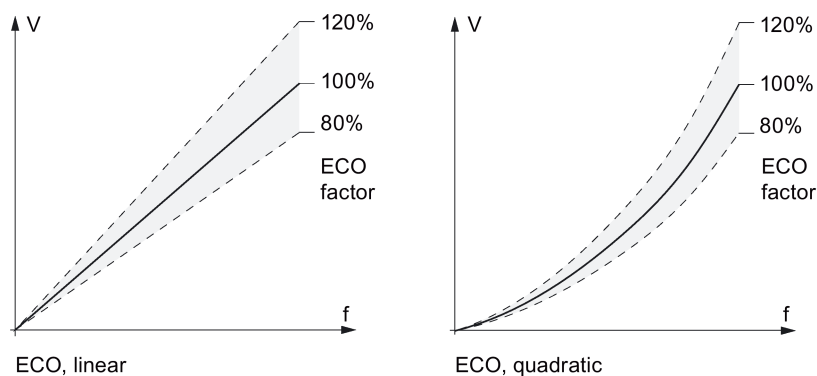

### 5.6.3.5 Setting the UL508C-compliant motor overtemperature protection

#### Functionality

The function protects the motor from overtemperature. The function defines the reaction of the inverter when motor temperature reaches warning threshold. The inverter can remember the current motor temperature on power-down and reacts on the next power-up based on the setting in P0610. Setting any value in P0610 other than 0 or 4 will cause the inverter to trip (F11) if the motor temperature is 10% above the warning threshold P0604.

---

#### Note

In order to comply with UL508C, parameter P0610 must not be changed from its factory setting of 6.

---

#### Setting parameters

Parameter	Function	Setting
P0610[0...2]	Motor I <sup>2</sup> t temperature reaction	<p>This parameter defines reaction when motor temperature reaches warning threshold.</p> <p>Settings 0 to 2 do not recall the motors temperature (stored at power-down) on power-up:</p> <ul style="list-style-type: none"> <li>= 0: Warning only</li> <li>= 1: Warning with I<sub>max</sub> control (motor current reduced) and trip (F11)</li> <li>= 2: Warning and trip (F11)</li> </ul> <p>Settings 4 to 6 recall the motors temperature (stored at power-down) on power-up:</p> <ul style="list-style-type: none"> <li>= 4: Warning only</li> <li>= 5: Warning with I<sub>max</sub> control (motor current reduced) and trip (F11)</li> <li>= 6: Warning and trip (F11)</li> </ul>

### 5.6.3.6 Setting the free function blocks (FFBs)

#### Functionality

Additional signal interconnections in the inverter can be established by means of the free function blocks (FFBs). Every digital and analog signal available via BICO technology can be routed to the appropriate inputs of the free function blocks. The outputs of the free function blocks are also interconnected to other functions using BICO technology.

#### Example

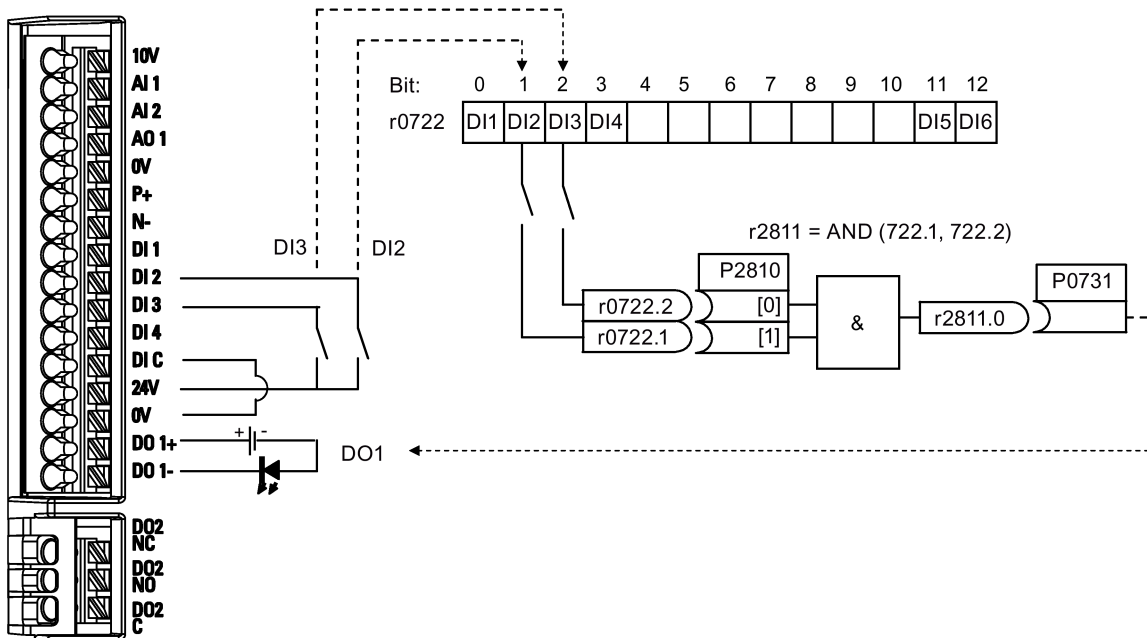

#### Setting parameters

Parameter	Function	Setting
P0702	Function of digital input 2	= 99: Enable BICO parameterization for digital input 2
P0703	Function of digital input 3	= 99: Enable BICO parameterization for digital input 3
P2800	Enable FFBs	= 1: Enable (general enable for all free function blocks)
P2801[0]	Activate FFBs	= 1: Enable AND 1
P2810[0]	BI: AND 1	= 722.1
P2810[1]		= 722.2
P0731	BI: Function of digital output 1	This parameter defines source of digital output 1. = r2811.0: Use the AND (DI2, DI3) to switch on LED

For more information about FFBs and additional settings of individual parameter, see Chapter "Parameter list (Page 147)".

### 5.6.3.7 Setting the flying start function

#### Functionality

The flying start function (enabled using P1200) allows the inverter to be switched onto a motor which is still spinning by rapidly changing the output frequency of the inverter until the actual motor speed has been found. Then, the motor runs up to setpoint using the normal ramp time.

Flying start must be used in cases where the motor may still be turning (e.g. after a short mains break) or can be driven by the load. Otherwise, overcurrent trips will occur.

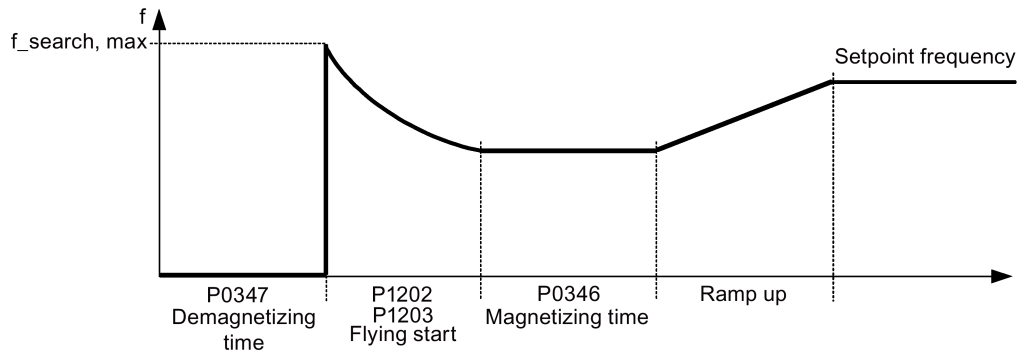

#### Setting parameters

Parameter	Function	Setting
P1200	Flying start	Settings 1 to 3 search in both directions: = 0: Flying start disabled = 1: Flying start always active = 2: Flying start active after power on, fault, OFF2 = 3: Flying start active after fault, OFF2 Settings 4 to 6 search only in the direction of the setpoint: = 4: Flying start always active = 5: Flying start active after power on, fault, OFF2 = 6: Flying start active after fault, OFF2
P1202[0...2]	Motor-current: flying start [%]	This parameter defines search current used for flying start. Range: 10 to 200 (factory default: 100) <b>Note:</b> Search current settings in P1202 that are below 30% (and sometimes other settings in P1202 and P1203) may cause motor speed to be found prematurely or too late, which can result in F1 or F2 trips.
P1203[0...2]	Search rate: flying start [%]	This parameter sets factor (in V/f mode only) by which the output frequency changes during flying start to synchronize with turning motor. Range: 10 to 500 (factory default: 100) <b>Note:</b> A higher value produces a flatter gradient and thus a longer search time. A lower value has the opposite effect.



### 5.6.3.8 Setting the automatic restart function

#### Functionality

After a power failure (F3 "Undervoltage"), the automatic restart function (enabled using P1210) automatically switches on the motor if an ON command is active. Any faults are automatically acknowledged by the inverter.

When it comes to power failures (line supply failure), then a differentiation is made between the following conditions:

- "Line undervoltage (mains brownout)" is a situation where the line supply is interrupted and returns before the built-in BOP display has gone dark (this is an extremely short line supply interruption where the DC link hasn't completely collapsed).
- "Line failure (mains blackout)" is a situation where the built-in BOP display has gone dark (this represents a longer line supply interruption where the DC link has completely collapsed) before the line supply returns.

#### Setting parameters

Parameter	Function	Setting
P1210	Automatic restart	This parameter configures automatic restart function. = 0: Disabled = 1: Trip reset after power on, P1211 disabled = 2: Restart after mains blackout, P1211 disabled = 3: Restart after mains brownout or fault, P1211 enabled = 4: Restart after mains brownout, P1211 enabled = 5: Restart after mains blackout and fault, P1211 disabled = 6: Restart after mains brown / blackout or fault, P1211 enabled = 7: Restart after mains brown / blackout or fault, trip when P1211 expires
P1211	Number of restart attempts	This parameter specifies number of times inverter will attempt to restart if automatic restart P1210 is activated. Range: 0 to 10 (factory default: 3)

### 5.6.3.9 Running the inverter in frost protection mode

#### Functionality

If the surrounding temperature falls below a given threshold, motor turns automatically to prevent freezing.

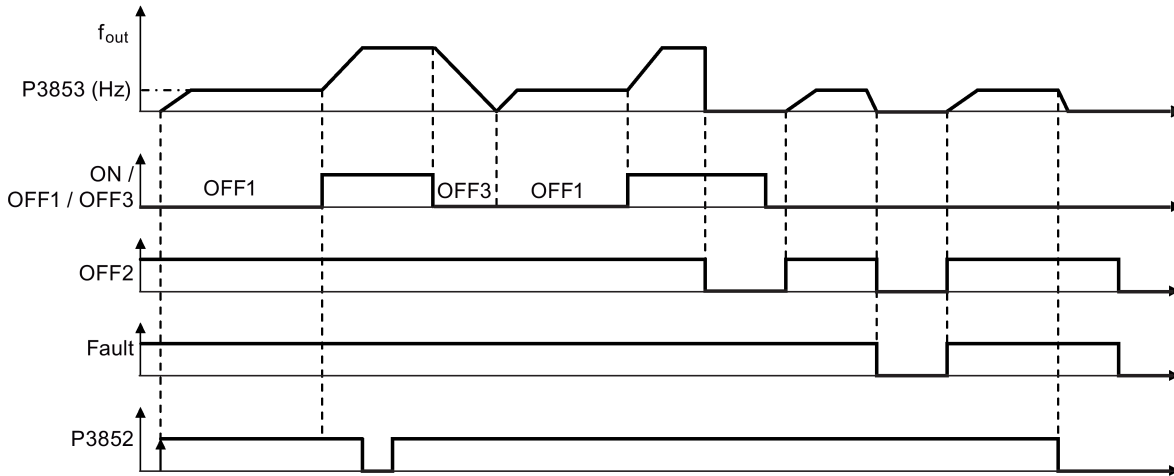

- OFF1 / OFF3: The frost protection function is disabled when OFF3 is activated and enabled again when OFF1 is activated.
- OFF2 / fault: The motor stops and the frost protection is deactivated.

#### Setting parameters

Parameter	Function	Setting
P3852[0...2]	BI: Enable frost protection	<p>This parameter defines command source of protection enable command. If binary input is equal to one, then protection will be initiated (factory default: 0).</p> <p>If P3853 ≠ 0, frost protection is applied by applying the given frequency to the motor.</p> <p>Note that the protection function may be overridden under the following circumstances:</p> <ul style="list-style-type: none"> <li>• If inverter is running and protection signal becomes active, signal is ignored</li> <li>• If inverter is turning motor due to active protection signal and a RUN command is received, RUN command overrides frost signal</li> <li>• Issuing an OFF command while protection is active will stop the motor</li> </ul>
P3853[0...2]	Frost protection frequency [Hz]	<p>This parameter specifies the frequency applied to the motor when frost protection is active.</p> <p>Range: 0.00 to 550.00 (factory default: 5.00)</p>

### 5.6.3.10 Running the inverter in condensation protection mode

#### Functionality

If an external condensation sensor detects excessive condensation, the inverter applies a DC current to keep the motor warm to prevent condensation.

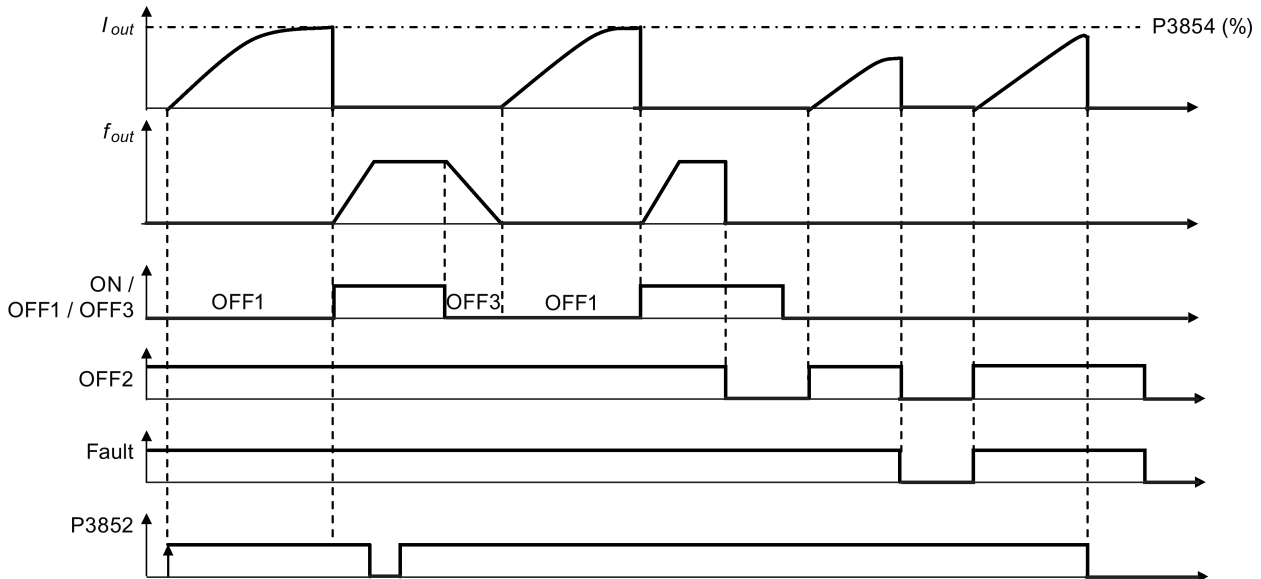

- OFF1 / OFF3: The condensation protection function is disabled when OFF3 is activated and enabled again when OFF1 is activated.
- OFF2 / fault: The motor stops and the condensation protection is deactivated.

#### Setting parameters

Parameter	Function	Setting
P3852[0...2]	BI: Enable frost protection	<p>This parameter defines command source of protection enable command. If binary input is equal to one, then protection will be initiated (factory default: 0).</p> <p>If P3853 = 0 and P3854 ≠ 0, condensation protection is applied by applying the given current to the motor.</p> <p>Note that the protection function may be overridden under the following circumstances:</p> <ul style="list-style-type: none"> <li>• If inverter is running and protection signal becomes active, signal is ignored</li> <li>• If inverter is turning motor due to active protection signal and a RUN command is received, RUN command overrides frost signal</li> <li>• Issuing an OFF command while protection is active will stop the motor</li> </ul>
P3854[0...2]	Condensation protection current [%]	<p>This parameter specifies the DC current (as a percentage of nominal current) which is applied to the motor when condensation protection is active.</p> <p>Range: 0 to 250 (factory default: 100)</p>

### 5.6.3.11 Running the inverter in sleep mode

#### Functionality

The motor is turned off if demand falls below threshold, and turned on if demand rises above threshold.

Required response of simple hibernation (sleep mode)

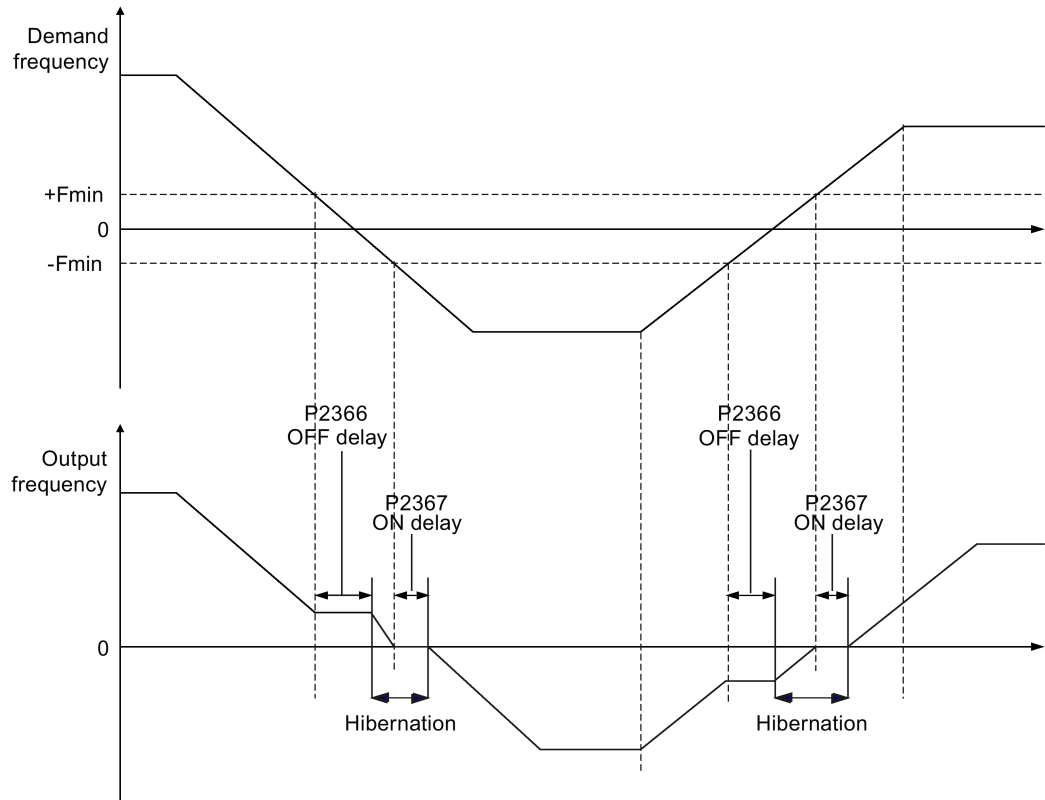

#### Setting parameters

Parameter	Function	Setting
P2365[0...2]	Hibernation enable / disable	This parameter enables or disables the hibernation functionality. = 0: Disabled (factory default) = 1: Enabled
P2366[0...2]	Delay before stopping motor [s]	With hibernation enabled, this parameter defines the delay before the inverter goes into sleep mode. Range: 0 to 254 (factory default: 5)
P2367[0...2]	Delay before starting motor [s]	With hibernation enabled, this parameter defines the delay before the inverter comes out of sleep mode. Range: 0 to 254 (factory default: 2)

Parameter	Function	Setting
P1080[0...2]	Minimum frequency [Hz]	Sets minimum motor frequency at which motor will run irrespective of frequency setpoint. Value set here is valid both for clockwise and for anticlockwise rotation. Range: 0.00 to 550.00 (factory default: 0.00)

### 5.6.3.12 Setting the wobble generator

#### Functionality

The wobble generator executes predefined periodical disruptions superimposed on the main setpoint for technological usage in the fiber industry. The wobble function can be activated via P2940. It is independent of the setpoint direction, thus only the absolute value of the setpoint is relevant. The wobble signal is added to the main setpoint as an additional setpoint. During the change of the setpoint the wobble function is inactive. The wobble signal is also limited by the maximum frequency (P1082).

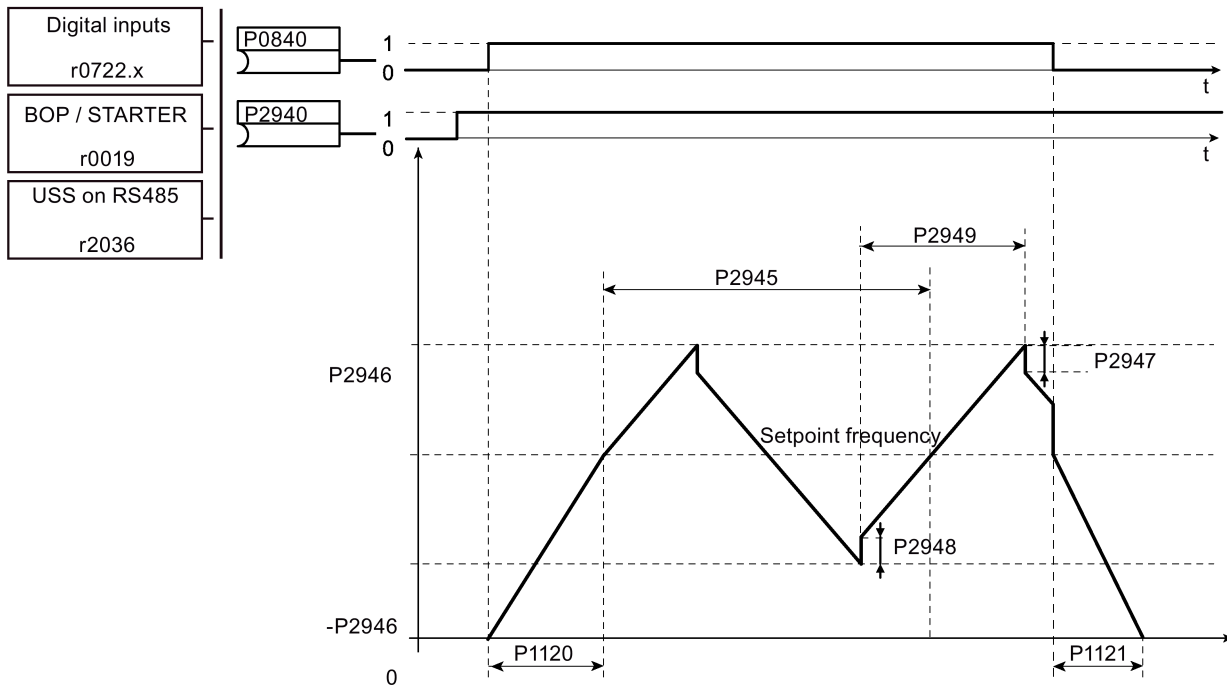

Wobble function disturb signal

#### Setting parameters

Parameter	Function	Setting
P2940	BI: Release wobble function	This parameter defines the source to release the wobble function. Factory default: 0.0
P2945	Wobble signal frequency [Hz]	This parameter sets the frequency of the wobble signal. Range: 0.001 to 10.000 (factory default: 1.000)

Parameter	Function	Setting
P2946	Wobble signal amplitude [%]	This parameter sets the value for the amplitude of the wobble-signal as a proportion of the present ramp function generator (RFG) output. Range: 0.000 to 0.200 (factory default: 0.000)
P2947	Wobble signal decrement step	This parameter sets the value for decrement step at the end of the positive signal period. Range: 0.000 to 1.000 (factory default: 0.000)
P2948	Wobble signal increment step	This parameter sets the value for the increment step at the end of the negative signal period. Range: 0.000 to 1.000 (factory default: 0.000)
P2949	Wobble signal pulse width [%]	This parameter sets the relative widths of the rising and falling pulses. Range: 0 to 100 (factory default: 50)

### 5.6.3.13 Running the inverter in motor staging mode

#### Functionality

Motor staging allows the control of up to 2 additional staged pumps or fans, based on a PID control system. The complete system consists of one pump controlled by the inverter and up to 2 further pumps / fans controlled from contactors or motor starters. The contactors or motor starter are controlled by digital outputs from the inverter.

The diagram below shows a typical pumping system.

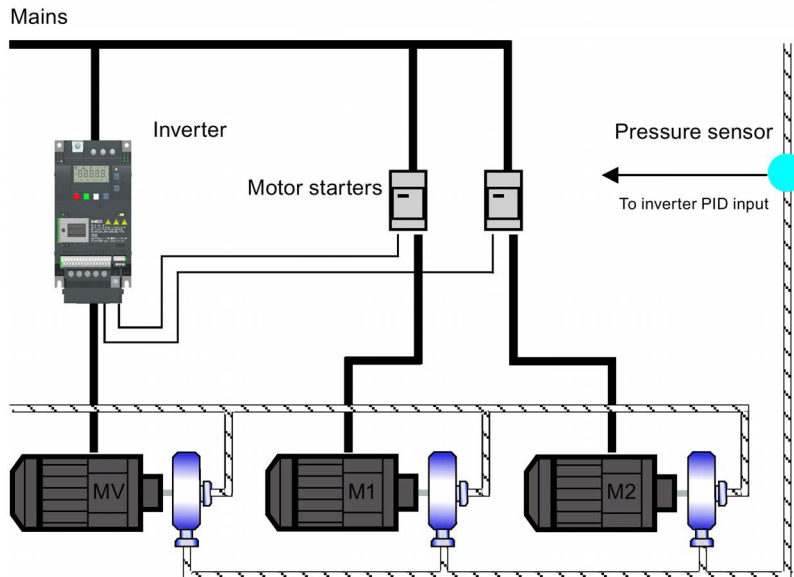

**Staging:**

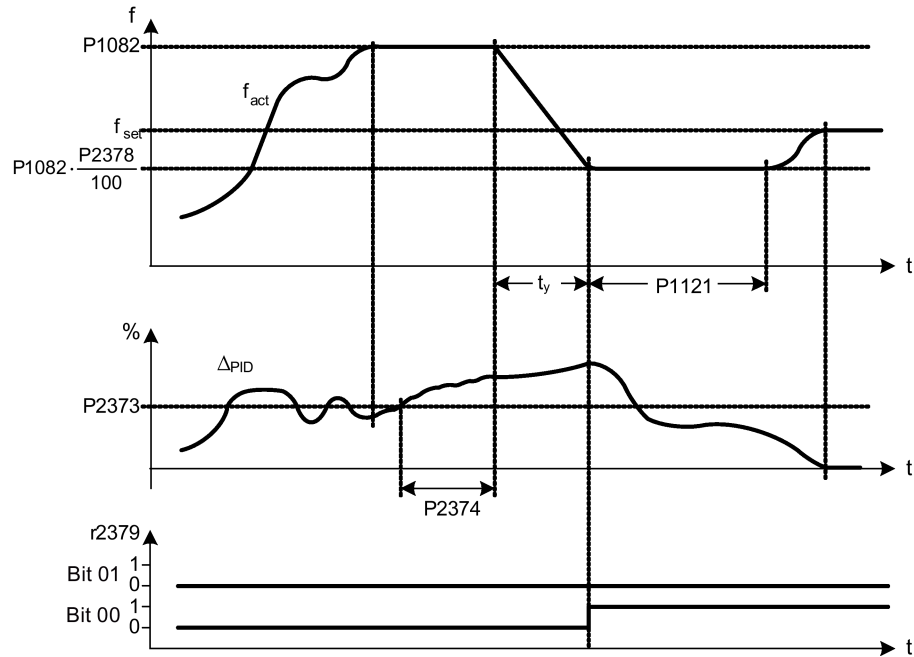

Condition for staging:

- Ⓐ  $f_{act} \geq P1082$
- Ⓑ  $\Delta_{PID} \geq P2373$
- Ⓒ  $t_{\text{a}\text{b}} > P2374$

$$t_y = \left(1 - \frac{P2378}{100}\right) \cdot P1121$$

**Destaging:**

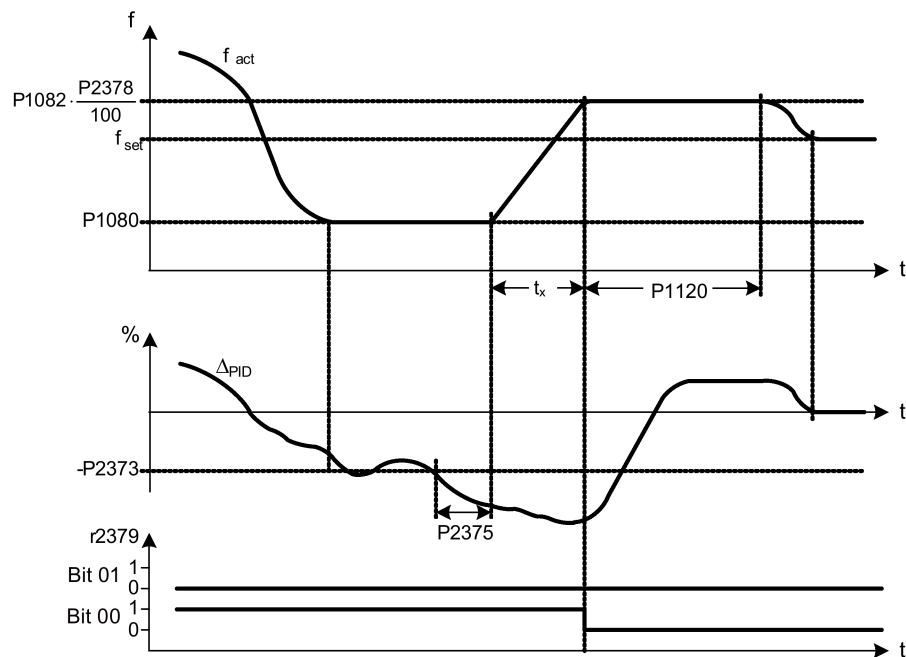

Condition for destaging:

- Ⓐ  $f_{act} \leq P1080$
- Ⓑ  $\Delta_{PID} \leq -P2373$
- Ⓒ  $t_{\text{a}\text{b}} > P2375$

$$t_x = \left(\frac{P2378}{100} - \frac{P1080}{P1082}\right) \cdot P1120$$

## Setting parameters

Parameter	Function	Setting
P2370[0...2]	Motor staging stop mode	This parameter selects stop mode for external motors when motor staging is in use. = 0: Normal stop (factory default) = 1: Sequence stop
P2371[0...2]	Motor staging configuration	This parameter selects configuration of external motors (M1, M2) used for motor staging feature. = 0: Motor staging disabled = 1: M1 = 1 x MV, M2 = Not fitted = 2: M1 = 1 x MV, M2 = 1 x MV = 3: M1 = 1 x MV, M2 = 2 x MV
P2372[0...2]	Motor staging cycling	This parameter enables motor cycling for the motor staging feature. = 0: Disabled (factory default) = 1: Enabled
P2373[0...2]	Motor staging hysteresis [%]	P2373 as a percentage of PID setpoint that PID error P2273 must be exceeded before staging delay starts. Range: 0.0 to 200.0 (factory default: 20.0)
P2374[0...2]	Motor staging delay [s]	This parameter defines the time that PID error P2273 must exceed motor staging hysteresis P2373 before staging occurs. Range: 0 to 650 (factory default: 30)
P2375[0...2]	Motor destaging delay [s]	This parameter defines the time that PID error P2273 must exceed motor staging hysteresis P2373 before destaging occurs. Range: 0 to 650 (factory default: 30)
P2376[0...2]	Motor staging delay override [%]	P2376 as a percentage of PID setpoint. When the PID error P2273 exceeds this value, a motor is staged / destaged irrespective of the delay timers. Range: 0.0 to 200.0 (factory default: 25.0) <b>Note:</b> The value of this parameter must always be larger than staging hysteresis P2373.
P2377[0...2]	Motor staging lockout timer [s]	This parameter defines the time for which delay override is prevented after a motor has been staged or destaged. Range: 0 to 650 (factory default: 30)
P2378[0...2]	Motor staging frequency f_st [%]	This parameter sets the frequency at which the digital output is switched during a (de) staging event, as the inverter ramps from maximum to minimum frequency (or vice versa). Range: 0.0 to 120.0 (factory default: 50.0)
r2379.0...1	CO / BO: Motor staging status word	This parameter displays output word from the motor staging feature that allows external connections to be made. Bit 00: Start motor 1 (yes for 1, no for 0) Bit 01: Start motor 2 (yes for 1, no for 0)
P2380[0...2]	Motor staging hours run [h]	This parameter displays hours run for external motors. <b>Index:</b> [0]: Motor 1 hrs run [1]: Motor 2 hrs run [2]: Not used Range: 0.0 to 4294967295 (factory default: 0.0)



### 5.6.3.14 Running the inverter in cavitation protection mode

#### Functionality

The cavitation protection will generate a fault / warning when cavitation conditions are deemed to be present. If the inverter gets no feedback from the pump transducer, it will trip to stop cavitation damage.

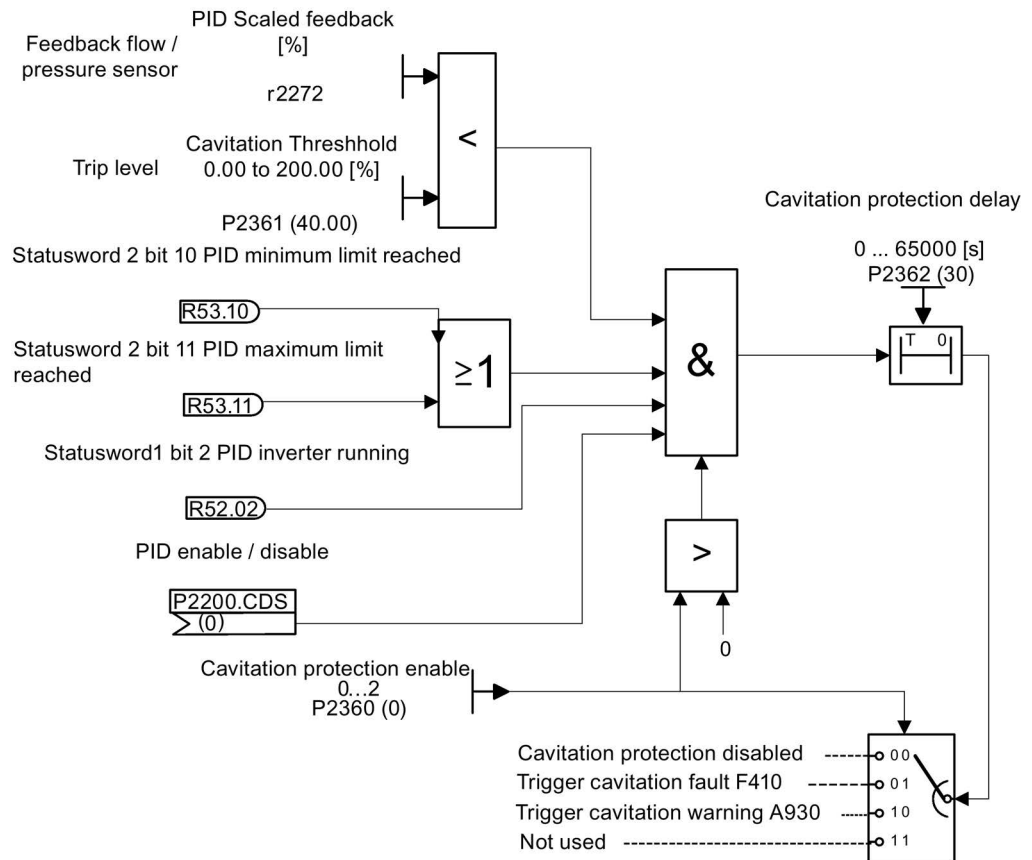

**Cavitation Protection Logic Diagram**

#### Setting parameters

Parameter	Function	Setting
P2360[0...2]	Enable cavitation protection	This parameter enables the cavitation protection function. = 1: Fault = 2: Warn
P2361[0...2]	Cavitation threshold [%]	This parameter defines the feedback threshold over which a fault / warning is triggered, as a percentage (%). Range: 0.00 to 200.00 (factory default: 40.00)

Parameter	Function	Setting
P2362[0...2]	Cavitation protection time [s]	This parameter sets the time for which cavitation conditions have to be present before a fault / warning is triggered. Range: 0 to 65000 (factory default: 30)

### 5.6.3.15 Setting the user default parameter set

#### Functionality

The user default parameter set allows a modified set of defaults, different to the factory defaults, to be stored. Following a parameter reset these modified default values would be used. An additional factory reset mode would be required to erase the user default values and restore the inverter to factory default parameter set.

#### Creating the user default parameter set

1. Parameterize the inverter as required.
2. Set P0971 = 21, and the current inverter state is now stored as the user default.

#### Modifying the user default parameter set

1. Return the inverter to the default state by setting P0010 = 30 and P0970 = 1. The inverter is now in the user default state if configured, else factory default state.
2. Parameterize the inverter as required.
3. Set P0971 = 21 to store current state as the user default.

#### Setting parameters

Parameter	Function	Setting
P0010	Commissioning parameter	This parameter filters parameters so that only those related to a particular functional group are selected. It must be set to 30 in order to store or delete user defaults. = 30: Factory setting
P0970	Factory reset	This parameter resets all parameters to their user default / factory default values. = 1: Parameter reset to user defaults if stored else factory defaults = 21: Parameter reset to factory defaults deleting user defaults if stored
P0971	Transfer data from RAM to EEPROM	This parameter transfers values from RAM to EEPROM. = 1: Start transfer = 21: Start transfer and store parameter changes as user default values

For information about restoring the inverter to factory defaults, refer to Section "Restoring to defaults (Page 132)".

### 5.6.3.16 Setting the dual ramp function

#### Functionality

The dual ramp function allows the user to parameterize the inverter so that it can switch from one ramp rate to another when ramping up or down to a setpoint. This may be useful for delicate loads, where starting to ramp with a fast ramp-up or ramp-down time may cause damage. The function works as follows:

#### Ramp up:

- Inverter starts ramp-up using ramp time from P1120
- When  $f_{act} > P2157$ , switch to ramp time from P1060

#### Ramp down:

- Inverter starts ramp-down using ramp time from P1061
- When  $f_{act} < P2159$ , switch to ramp time from P1121

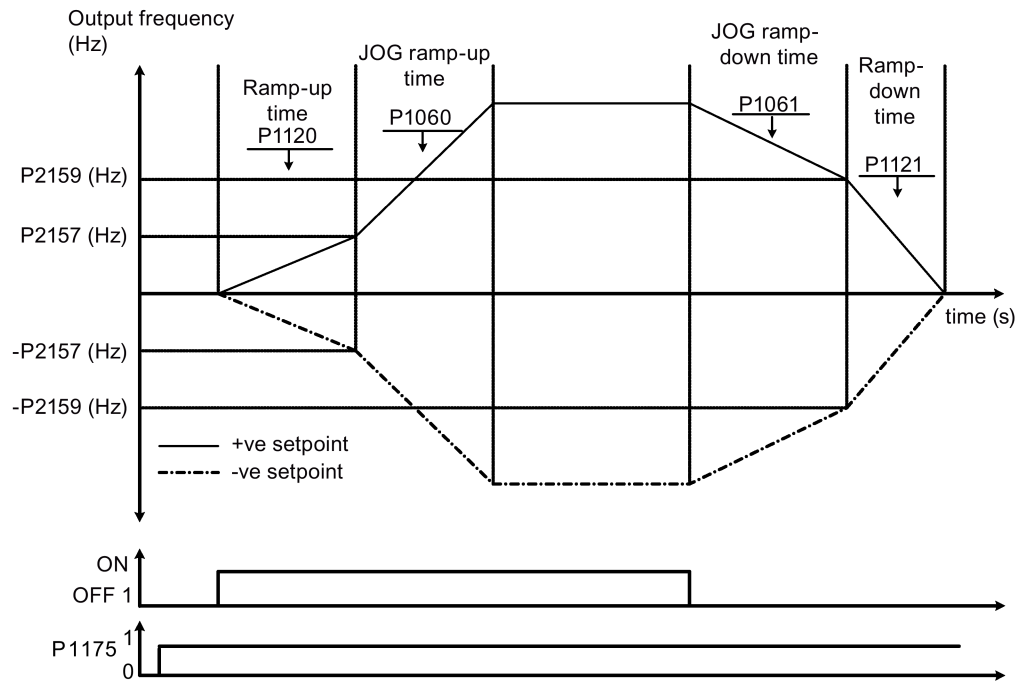

Note that the dual ramp algorithm uses r2198 bits 1 and 2 to determine ( $f_{act} > P2157$ ) and ( $f_{act} < P2159$ ).

## Setting parameters

Parameter	Function	Setting
P1175[0...2]	BI: Dual ramp enable	This parameter defines command source of dual ramp enable command. If binary input is equal to one, then the dual ramp will be applied. The factory default value is 0.
P1060[0...2]	JOG ramp-up time [s]	This parameter sets the JOG ramp-up time. Range: 0.00 to 650.00 (factory default: 10.00)
P1061[0...2]	JOG ramp-down time [s]	This parameter sets the JOG ramp-down time. Range: 0.00 to 650.00 (factory default: 10.00)
P1120[0...2]	Ramp-up time [s]	This parameter sets the time taken for motor to accelerate from standstill up to maximum frequency (P1082) when no rounding is used. Range: 0.00 to 650.00 (factory default: 10.00)
P1121[0...2]	Ramp-down time [s]	This parameter sets the time taken for motor to decelerate from maximum frequency (P1082) down to standstill when no rounding is used. Range: 0.00 to 650.00 (factory default: 10.00)
P2157[0...2]	Threshold frequency f_2 [Hz]	This parameter defines threshold_2 for comparing speed or frequency to thresholds. Range: 0.00 to 550.00 (factory default: 30.00)
P2159[0...2]	Threshold frequency f_3 [Hz]	This parameter defines threshold_3 for comparing speed or frequency to thresholds. Range: 0.00 to 550.00 (factory default: 30.00)

## 5.6.3.17 Setting the DC coupling function

## Functionality

The SINAMICS V20 inverter provides the facility to electrically couple two equal-size inverters together by using the DC link connections. The key benefits of this connection are:

- Reducing energy costs by using regenerative energy from one inverter as driving energy in the second inverter.
- Reducing installation costs by allowing the inverters to share one common dynamic braking module when needed.
- In some applications, eliminating the need for the dynamic braking module.

In the most common application, shown in the following figure, linking two SINAMICS V20 inverters of equal size and rating allows the energy from one inverter, presently decelerating a load, to be fed into the second inverter across the DC link. This requires less energy to be sourced from the mains supply. In this scenario, the total electricity consumption is reduced.

## Connection for DC coupling

The following figure illustrates the system connection using DC coupling.

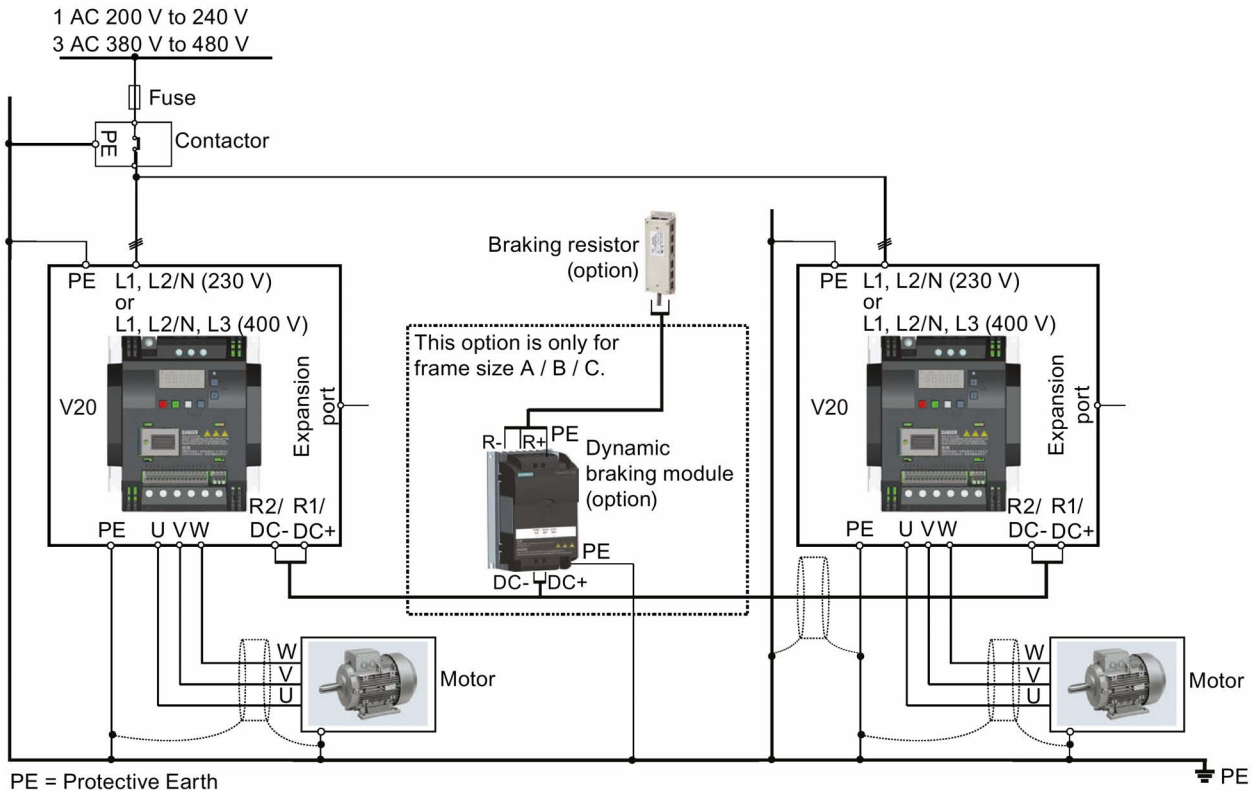

See Sections "Typical system connections (Page 37)" and "Terminal description (Page 40)" for the recommended fuse types, cable cross-sections and screw tightening torques.

### **WARNING**

#### **Destruction of inverter**

It is extremely important to ensure that the polarity of the DC link connections between the inverters is correct. If the polarity of the DC terminals' connections is reversed, it could result in the destruction of the inverter.

### **CAUTION**

#### **Safety awareness**

The coupled SINAMICS V20 inverters must both be of equal power and supply voltage rating.

The coupled inverters must be connected to the mains supply through a single contactor and fuse arrangement rated for a single inverter of the type in use.

A maximum of two SINAMICS V20 inverters can be linked using the DC coupling methodology.

**NOTICE**

**Integrated braking chopper**

The integrated braking chopper within the frame size D inverter is only active if the inverter receives an ON command and is actually running. When the inverter is powered down, the regenerative energy cannot be pulsed to the external braking resistor.

**Limitations and restrictions**

- The maximum length of the coupling cable is 3 metres.
- For the inverters of frame sizes A to C, if a dynamic braking module is to be used, an additional connector with a current rating the same as the supply cable to one inverter must be used to connect the dynamic braking module wires to DC+ and DC- since the Inverter terminals may not support an additional connection.
- The cable rating to the dynamic braking module needs to be at least 9.5 A for a 5.5 kW full power rating (as measured using a minimum resistor value of 56 Ω). Screened cable should be used.
- For the inverters of frame size D for three phase, the dynamic braking circuit is self-contained and only one external braking resistor has to be attached to one of the inverters. Refer to Appendix "Braking resistor (Page 316)" for the selection of an appropriate braking resistor.
- The compound braking must never be activated.

---

**Note**

**Performance and potential energy savings**

The performance and potential energy savings using the DC coupling function is highly dependent on the specific application. Therefore, Siemens makes no claim regarding the performance and energy saving potential of the DC coupling methodology.

---

**Note**

**Standards and EMC disclaimers**

The DC coupling configuration with the SINAMICS V20 inverters is not certified for use in UL / cUL applications.

No claims are made regarding the EMC performance of this configuration.

---

### 5.6.3.18 Setting high/low overload (HO/LO) mode

#### Functionality

Setting HO/LO overload enables you to select the low-overload mode for pumps and fans, the most important target applications of SINAMICS V20 inverters. Low-overload mode can improve the rated output current of the inverter and therefore allows the inverter to drive motors of higher power.

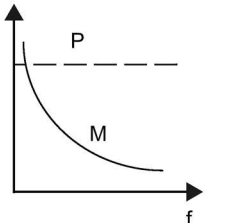
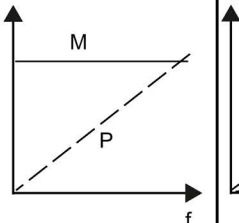
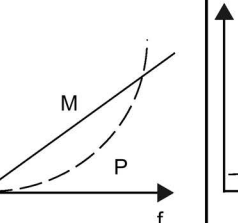
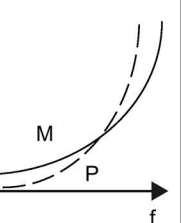
Torque	$M \sim \frac{1}{f}$	$M = \text{const.}$	$M \sim f$	$M \sim f^2$
Power	$p = \text{const.}$	$p \sim f$	$p \sim f^2$	$p \sim f^3$
Characteristic				
Application	Winders Facing lathes Rotary cutting machines	Hoisting gear Belt conveyors Process machines involving forming Rolling mills Planers Compressors	Calenders with viscous friction Eddy-current brakes	Pumps Fans Centrifuges

#### Typical application fields

- High overload: conveyors, agitators and centrifuges
- Low overload: pumps and fans

#### Power ratings

Rated power rating (HO mode)	18.5 kW	22 kW
Rated power rating (LO mode)	22 kW	30 kW

Taking the 22 kW SINAMICS inverter as an example, when HO mode is selected, it means the rated power rating is 22 kW; when LO mode is selected, the rated power rating is changed to 30 kW.

- HO mode
  - Overload capability: 150% of the rated output current for 60 s
  - Cycle time: 300 s
- LO mode:
  - Overload capability: 110% of the rated output current for 60 s
  - Cycle time: 300 s

Setting parameter

Parameter	Function	Setting
P0205	Select inverter applications	This parameter selects the inverter applications on high overload and low overload: =0: high overload =1: low overload

Function diagram

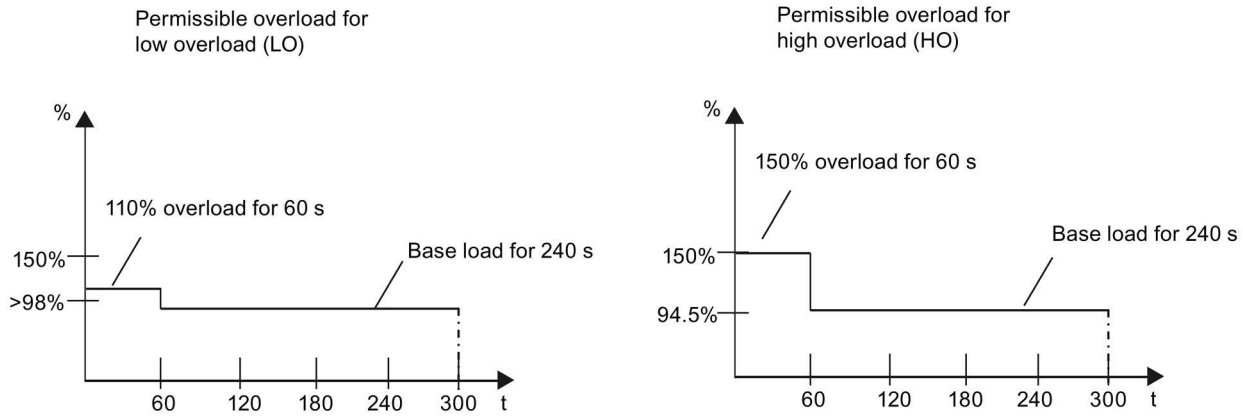

5.7 Restoring to defaults

Restoring to factory defaults

Parameter	Function	Setting
P0003	User access level	= 1 (standard user access level)
P0010	Commissioning parameter	= 30 (factory setting)
P0970	Factory reset	= 21: parameter reset to factory defaults deleting user defaults if stored

Restoring to user defaults

Parameter	Function	Setting
P0003	User access level	= 1 (standard user access level)
P0010	Commissioning parameter	= 30 (factory setting)
P0970	Factory reset	= 1: parameter reset to user defaults if stored, else factory defaults

After setting the parameter P0970, the inverter displays "8 8 8 8" and then the screen shows "P0970". P0970 and P0010 are automatically reset to their original value 0.



## Communicating with the PLC

The SINAMICS V20 supports communication with Siemens PLCs over USS on RS485. You can parameterize whether the RS485 interface shall apply USS or MODBUS RTU protocol. USS is the default bus setting. A screened twisted pair cable is recommended for the RS485 communication.

Make sure that you terminate the bus correctly by fitting a 120 R bus termination resistor between the bus terminals (P+, N-) of the device at one end of the bus and a termination network between the bus terminals of the device at the other end of the bus. The termination network should be a 1.5 k resistor from 10 V to P+, 120 R from P+ to N- and 470 R from N- to 0 V. A suitable termination network is available from your Siemens dealer.

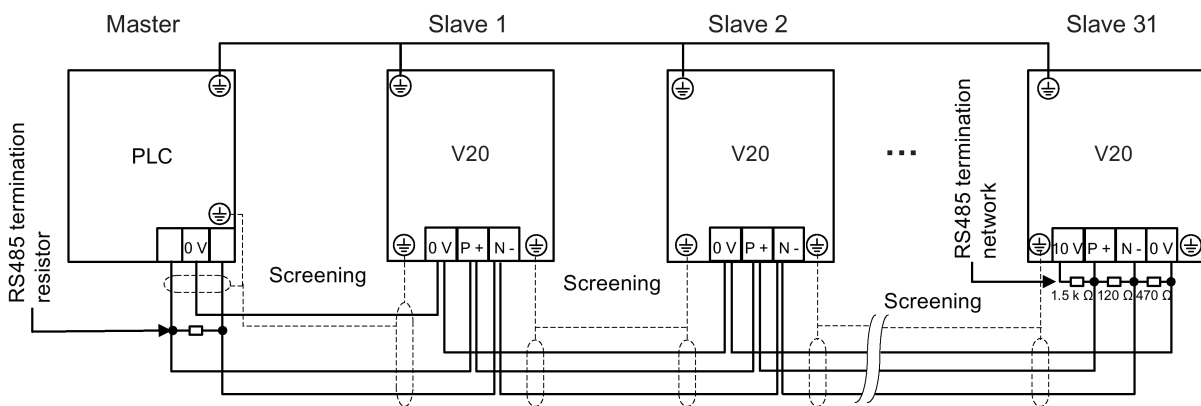

### 6.1 USS communication

#### Overview

One PLC (master) can connect a maximum of 31 inverters (slaves) through the serial link and control them with the USS serial bus protocol. A slave can never transmit without first being initiated by the master so that direct information transfer between individual slaves is not possible.

Data exchanging:

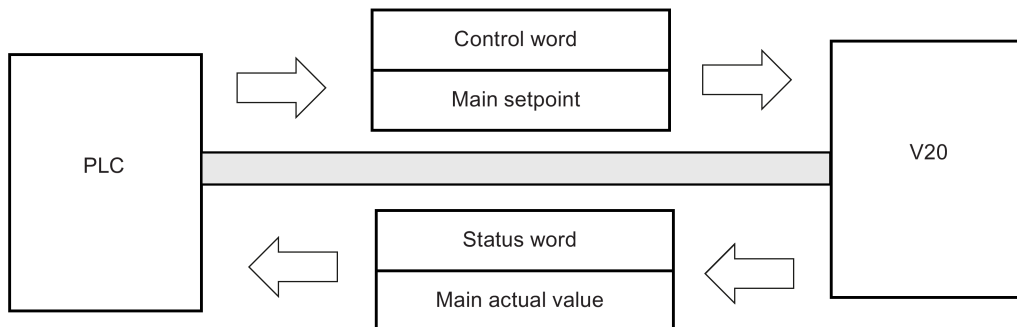

The messages are always sent in the following format (half-duplex communication):

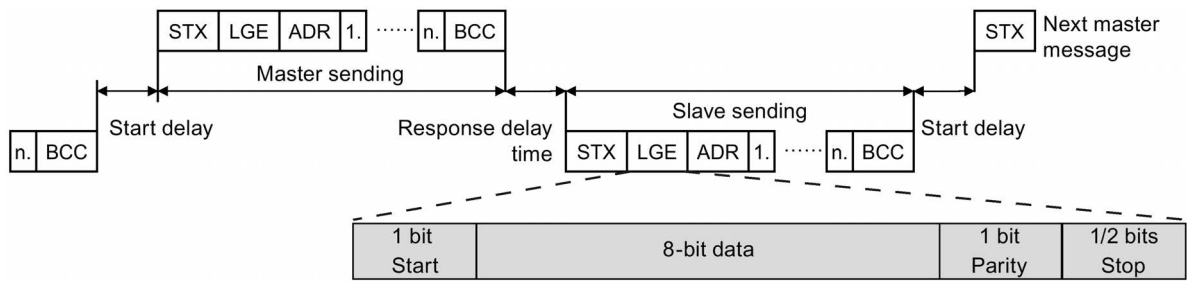

- Response delay time: 20 ms
- Start delay time: depends on baud rate (minimum operation time for 2-character string: 0.12 to 2.3 ms)
- Message transfer sequence:
  - master polls slave 1, then slave 1 responds
  - master polls slave 2, then slave 2 responds
- Fixed framing characters that can not be altered:
  - 8 data bits
  - 1 parity bit
  - 1 or 2 stop bits

Abbreviation	Significance	Length	Explanation
STX	Start of text	ASCII characters	02 hex
LGE	Telegram length	1 byte	Contains the telegram length
ADR	Address	1 byte	Contains the slave address and the telegram type (binary coded)
1. .... n.	Net characters	Each 1 byte	Net data, contents are dependent on the request
BCC	Block check character	1 byte	Data security characters

**Request and response IDs**

Request and response IDs are written in bits 12 to 15 of the PKW (parameter ID value) part of USS telegram.

**Request IDs (master → slave)**

Request ID	Description	Response ID	
		positive	negative
0	No request	0	7/8
1	Request parameter value	1/2	7/8
2	Modify parameter value (word)	1	7/8
3	Modify parameter value (double word)	2	7/8

Request ID	Description	Response ID	
		positive	negative
4	Request descriptive element	3	7/8
6	Request parameter value (array)	4/5	7/8
7	Modify parameter value (array, word)	4	7/8
8	Modify parameter value (array, double word)	5	7/8
9	Request number of array elements	6	7/8
11	Modify parameter value (array, double word) and store in EEPROM	5	7/8
12	Modify parameter value (array, word) and store in EEPROM	4	7/8
13	Modify parameter value (double word) and store in EEPROM	2	7/8
14	Modify parameter value (word) and store in EEPROM	1	7/8

#### Response IDs (slave → master)

Response ID	Description
0	No response
1	Transfer parameter value (word)
2	Transfer parameter value (double word)
3	Transfer descriptive element
4	Transfer parameter value (array, word)
5	Transfer parameter value (array, double word)
6	Transfer number of array elements
7	Request cannot be processed, task cannot be executed (with error number)
8	No master controller status/no parameter change rights for PKW interface

#### Error numbers in response ID 7 (request cannot be processed)

No.	Description
0	Illegal PNU (illegal parameter number; parameter number not available)
1	Parameter value cannot be changed (parameter is read-only)
2	Lower or upper limit violated (limit exceeded)
3	Wrong sub-index
4	No array
5	Wrong parameter type/incorrect data type
6	Setting is not allowed (parameter value can only be reset to zero)
7	The descriptive element is not changeable and can only be read
9	Descriptive data not available
10	Access group incorrect
11	No parameter change rights. See parameter P0927. Must have status as master control.
12	Incorrect password
17	The current inverter operating status does not permit the request processing
18	Other error
20	Illegal value. Change request for a value which is within the limits, but it is not allowed for other reasons (parameter with defined single values)

6.1 USS communication

No.	Description
101	Parameter is currently deactivated; parameter has no function in the present inverter status
102	Communication channel width is insufficient for response; dependent on the number of PKW and the maximum net data length of the inverter
104	Illegal parameter value
105	Parameter is indexed
106	Request is not included/task is not supported
109	PKW request access timeout/number of retries is exceeded/wait for response from CPU side
110	Parameter value cannot be changed (parameter is locked)
200/201	Changed lower/upper limits exceeded
202/203	No display on the BOP
204	The available access authorization does not cover parameter changes
300	Array elements differ

Basic inverter settings

Parameter	Function	Setting
P0010	Commissioning parameter	= 30: restores to factory settings
P0970	Factory reset	Possible settings: = 1: resets all parameters (not user defaults) to their default values = 21: resets all parameters and all user defaults to factory reset state <b>Note:</b> Parameters P2010, P2011, P2023 retain their values after a factory reset.
P0003	User access level	= 3
P0700	Selection of command source	= 5: USS/MODBUS on RS485 Factory default: 1 (operator panel)
P1000	Selection of frequency setpoint	= 5: USS/MODBUS on RS485 Factory default: 1 (MOP setpoint)
P2023	RS485 protocol selection	= 1: USS (factory default) <b>Note:</b> After changing P2023, powercycle the inverter. During the powercycle, wait until LED has gone off or the display has gone blank (may take a few seconds) before re-applying power. If P2023 has been changed via a PLC, make sure the change has been saved to EEPROM via P0971.
P2010[0]	USS/MODBUS baudrate	Possible settings: = 6: 9600 bps (factory default) = 7: 19200 bps = 8: 38400 bps ... = 12: 115200 bps
P2011[0]	USS address	Sets the unique address for the inverter. Range: 0 to 31 (factory default: 0)

Parameter	Function	Setting
P2012[0]	USS PZD (process data) length	Defines the number of 16-bit words in PZD part of USS telegram. Range: 0 to 8 (factory default: 2)
P2013[0]	USS PKW (parameter ID value) length	Defines the number of 16-bit words in PKW part of USS telegram. Possible settings: = 0, 3, 4: 0, 3 or 4 words = 127: variable length (factory default)
P2014[0]	USS/MODBUS telegram off time [ms]	If time set to 0, no fault is generated (i.e. watchdog disabled).
r2024[0] ... r2031[0]	USS/MODBUS error statistics	The state of the telegram information on RS485 is reported regardless of the protocol set in P2023.
r2018[0...7]	CO: PZD from USS/MODBUS on RS485	Displays process data received via USS/MODBUS on RS485.
P2019[0...7]	CI: PZD to USS/MODBUS on RS485	Displays process data transmitted via USS/MODBUS on RS485.
P2034	MODBUS parity on RS485	Sets the parity of MODBUS telegrams on RS485. Possible settings: = 0: no parity = 1: odd parity = 2: even parity
P2035	MODBUS stop bits on RS485	Sets the number of stop bits in MODBUS telegrams on RS485. Possible settings: = 1: 1 stop bit = 2: 2 stop bits

## 6.2 MODBUS communication

### Overview

In MODBUS, only the master can start a communication and the slave will answer it. There are two ways of sending a message to a slave. One is unicast mode (address 1 to 247), where the master addresses the slave directly; the other is broadcast mode (address 0), where the master addresses all slaves.

When a slave has received a message, which was addressed at it, the Function Code tells it what to do. For the task defined by the Function Code, the slave may receive some data. And for error checking a CRC code is also included.

After receiving and processing a unicast message, the MODBUS slave will send a reply, but only if no error was detected in the received message. If a processing error occurs, the slave will reply with an error message. The following fixed framing characters in a message can not be altered: 8 data bits, 1 parity bit, and 1 or 2 stop bits.

Start pause	Application Data Unit					End pause
>= 3.5 Character run time	Slave Address		Protocol Data Unit		CRC	
			Function Code	Data		
	1 byte		1 byte	0 ... 252 bytes	CRC low	CRC high
				2 bytes		>= 3.5 Character run time

### Supported Function Codes

The SINAMICS V20 supports only three Function Codes. If a request with an unknown Function Code is received, an error message will be returned.

### FC3 - Read Holding Registers

When a message with FC = 0x03 is received, then 4 bytes of data are expected, that is, FC3 has 4 bytes of data:

- 2 bytes for the starting address of register
- 2 bytes for the number of registers

Byte 1	Byte 2	Byte 3	Byte 4	Byte 5	Byte 6	Byte 7	Byte 8
Address	FC (0x03)	Start address		Number of registers		CRC	
		High	Low	High	Low	High	Low

### Inverter response

Byte 1	Byte 2	Byte 3	Byte 4	Byte 5	...	Byte N*2 - 1	Byte N*2	Byte N*2 + 1	Byte N*2 + 2
Address	FC (0x03)	Number of bytes	Register 1 value		...	Register N value		CRC	
			High	Low		High	Low	High	Low

### FC6 - Write Single Register

When a message with FC = 0x06 is received, then 4 bytes of data are expected, that is, FC6 has 4 bytes of data:

- 2 bytes for the starting address of register
- 2 bytes for the register value

Byte 1	Byte 2	Byte 3	Byte 4	Byte 5	Byte 6	Byte 7	Byte 8
Address	FC (0x06)	Start address		New register value		CRC	
		High	Low	High	Low	High	Low

#### Inverter response

Byte 1	Byte 2	Byte 3	Byte 4	Byte 5	Byte 6	Byte 7	Byte 8
Address	FC (0x06)	Start address		New register value		CRC	
		High	Low	High	Low	High	Low

### FC16 - Write Multiple Registers

When a message with FC = 0x10 is received, then 5 + N bytes of data are expected, that is, FC16 has 5 + N bytes of data:

- 2 bytes for the starting address of register
- 2 bytes for the number of registers
- 1 byte for the byte count
- N bytes for the register values

Byte 1	Byte 2	Byte 3	Byte 4	Byte 5	Byte 6	Byte 7	...	Byte N - 1	Byte N	Byte N + 1	Byte N + 2
Address	FC (0x10)	Start address		Number of registers		Number of bytes	...	Register N value		CRC	
		High	Low	High	Low			High	Low	High	Low

#### Inverter response

Byte 1	Byte 2	Byte 3	Byte 4	Byte 5	Byte 6	Byte 7	Byte 8
Address	FC (0x10)	Start address		Number of registers		CRC	
		High	Low	High	Low	High	Low

### Exception Responses

If an error is detected through the MODBUS processing, the slave will respond with the FC of the request, but with most significant bit of the FC high and with the Exception Code in the data field. However, any error detected on the global address 0 does not result in a response since all slaves cannot respond at once.

If an error is detected within the received message (for example, parity error, incorrect CRC and so on), then NO response is sent to the master.

Note that if a request with FC16 is received which contains a write that the inverter cannot perform (including write to a zero entry), other valid writes will still be performed even though an exception response is returned.

The following MODBUS Exception Codes are supported by SINAMICS V20:

Exception Code	MODBUS name	Meaning
01	Illegal function code	The function code is not supported – only FC3, FC6 and FC16 are supported.
02	Illegal data address	An invalid address was queried.
03	Illegal data value	An invalid data value was recognized.
04	Slave device failure	An unrecoverable error occurred while the device was processing the action.

The table below shows the cases in which an Exception Code is returned:

Error description	Exception Code
Unknown Function Code	01
Read registers, which are out of boundary	02
Write register, which is out of boundary	02
Read request of too many registers (>125)	03
Write request of too many registers (>123)	03
Incorrect message length	03
Write to a read-only register	04
Write register, error in parameter access	04
Read register, error in Parameter Manager	04
Write to a zero entry	04
Unknown error	04

### Basic inverter settings

Parameter	Function	Setting
P0010	Commissioning parameter	= 30: restores to factory settings
P0970	Factory reset	Possible settings: = 1: resets all parameters (not user defaults) to their default values = 21: resets all parameters and all user defaults to factory reset state <b>Note:</b> Parameters P2010, P2021, P2023 retain their values after a factory reset.
P0003	User access level	= 3
P0700	Selection of command source	= 5: USS / MODBUS on RS485 Factory default: 1 (operator panel)



Parameter	Function	Setting
P2010[0]	USS / MODBUS baudrate	Possible settings: = 6: 9600 bps (factory default) = 7: 19200 bps = 8: 38400 bps ... =12 115200 bps
P2014[0]	USS/MODBUS telegram off time [ms]	If time set to 0, no fault is generated (i.e. watchdog disabled).
P2021	Modbus address	Sets the unique address for the inverter. Range: 1 to 247 (factory default: 1)
P2022	Modbus reply timeout [ms]	Range: 0 to 10000 (factory default: 1000)
P2023	RS485 protocol selection	= 2: Modbus Factory default: 1 (USS) <b>Note:</b> After changing P2023, powercycle the inverter. During the powercycle, wait until LED has gone off or the display has gone blank (may take a few seconds) before re-applying power. If P2023 has been changed via a PLC, make sure the change has been saved to EEPROM via P0971.
r2024[0] ... r2031[0]	USS/MODBUS error statistics	The state of the telegram information on RS485 is reported regardless of the protocol set in P2023.
r2018[0...7]	CO: PZD from USS/ MODBUS on RS485	Displays process data received via USS/MODBUS on RS485.
P2019[0...7]	CI: PZD to USS/MODBUS on RS485	Displays process data transmitted via USS/MODBUS on RS485.
P2034	MODBUS parity on RS485	Sets the parity of MODBUS telegrams on RS485. Possible settings: = 0: no parity = 1: odd parity = 2: even parity
P2035	MODBUS stop bits on RS485	Sets the number of stop bits in MODBUS telegrams on RS485. Possible settings: = 1: 1 stop bit = 2: 2 stop bits

**Mapping table**

The SINAMICS V20 inverter supports two sets of registers (40001 to 40062, 40100 to 40522) as the table below shows. "R", "W", "R/W" in the column Access stand for read, write, read/write.

HSW (speed setpoint), HIW (actual speed), STW (control word), ZSW (status word) refer to control data. For more information, see parameters r2018 and P2019 in Chapter "Parameter list (Page 147)".

Register No.		Description	Access	Unit	Scaling factor	Range or On/Off text		Read	Write
Inverter	MODBUS								
0	40001	WDOG TIME	R/W	ms	1	0 - 65535		-	-
1	40002	WDOG ACTION	R/W	-	1	-		-	-
2	40003	FREQ REF	R/W	%	100	0.00 - 100.00		HSW	HSW
3	40004	RUN ENABLE	R/W	-	1	0 - 1		STW:3	STW:3
4	40005	CMD FWD REV	R/W	-	1	0 - 1		STW:11	STW:11
5	40006	CMD START	R/W	-	1	0 - 1		STW:0	STW:0
6	40007	FAULT ACK	R/W	-	1	0 - 1		STW:7	STW:7
7	40008	PID SETP REF	R/W	%	100	-200.0 - 200.0		P2240	P2240
8	40009	ENABLE PID	R/W	-	1	0 - 1		r0055.8	(BICO) P2200
9	40010	CURRENT LMT	R/W	%	10	10.0 - 400.0		P0640	P0640
10	40011	ACCEL TIME	R/W	s	100	0.00 - 650.0		P1120	P1120
11	40012	DECEL TIME	R/W	s	100	0.00 - 650.0		P1121	P1121
12	40013	(Reserved)							
13	40014	DIGITAL OUT 1	R/W	-	1	HIGH	LOW	r0747.0	(BICO) P0731
14	40015	DIGITAL OUT 2	R/W	-	1	HIGH	LOW	r0747.1	(BICO) P0732
15	40016	REF FREQ	R/W	Hz	100	1.00 - 550.00		P2000	P2000
16	40017	PID UP LMT	R/W	%	100	-200.0 - 200.0		P2291	P2291
17	40018	PID LO LMT	R/W	%	100	-200.0 - 200.0		P2292	P2292
18	40019	P GAIN	R/W	-	1000	0.000 - 65.000		P2280	P2280
19	40020	I GAIN	R/W	s	1	0 - 60		P2285	P2285
20	40021	D GAIN	R/W	-	1	0 - 60		P2274	P2274
21	40022	FEEDBK GAIN	R/W	%	100	0.00 - 500.00		P2269	P2269
22	40023	LOW PASS	R/W	-	100	0.00 - 60.00		P2265	P2265
23	40024	FREQ OUTPUT	R	Hz	100	-327.68 - 327.67		r0024	r0024
24	40025	SPEED	R	RPM	1	-16250 - 16250		r0022	r0022
25	40026	CURRENT	R	A	100	0 - 163.83		r0027	r0027
26	40027	TORQUE	R	Nm	100	-325.00 - 325.00		r0031	r0031
27	40028	ACTUAL PWR	R	kW	100	0 - 327.67		r0032	r0032
28	40029	TOTAL KWH	R	kWh	1	0 - 32767		r0039	r0039
29	40030	DC BUS VOLTS	R	V	1	0 - 32767		r0026	r0026
30	40031	REFERENCE	R	Hz	100	-327.68 - 327.67		r0020	r0020
31	40032	RATED PWR	R	kW	100	0 - 327.67		r0206	r0206
32	40033	OUTPUT VOLTS	R	V	1	0 - 32767		r0025	r0025

Register No.		Description	Access	Unit	Scaling factor	Range or On/Off text		Read	Write
Inverter	MODBUS								
33	40034	FWD REV	R	-	1	FWD	REV	ZSW:14	ZSW:14
34	40035	STOP RUN	R	-	1	STOP	RUN	ZSW:2	ZSW:2
35	40036	AT MAX FREQ	R	-	1	MAX	NO	ZSW:10	ZSW:10
36	40037	CONTROL MODE	R	-	1	SERIAL	LOCAL	ZSW:9	ZSW:9
37	40038	ENABLED	R	-	1	ON	OFF	ZSW:0	ZSW:0
38	40039	READY TO RUN	R	-	1	READY	OFF	ZSW:1	ZSW:1
39	40040	ANALOG IN 1	R	%	100	-300.0 - 300.0		r0754[0]	r0754[0]
40	40041	ANALOG IN 2	R	%	100	-300.0 - 300.0		r0754[1]	r0754[1]
41	40042	ANALOG OUT 1	R	%	100	-100.0 - 100.0		r0774[0]	r0774[0]
43	40044	FREQ ACTUAL	R	%	100	-100.0 - 100.0		HIW	HIW
44	40045	PID SETP OUT	R	%	100	-100.0 - 100.0		r2250	r2250
45	40046	PID OUTPUT	R	%	100	-100.0 - 100.0		r2294	r2294
46	40047	PID FEEDBACK	R	%	100	-100.0 - 100.0		r2266	r2266
47	40048	DIGITAL IN 1	R	-	1	HIGH	LOW	r0722.0	r0722.0
48	40049	DIGITAL IN 2	R	-	1	HIGH	LOW	r0722.1	r0722.1
49	40050	DIGITAL IN 3	R	-	1	HIGH	LOW	r0722.2	r0722.2
50	40051	DIGITAL IN 4	R	-	1	HIGH	LOW	r0722.3	r0722.3
53	40054	FAULT	R	-	1	FAULT	OFF	ZSW:3	ZSW:3
54	40055	LAST FAULT	R	-	1	0 - 32767		r0947[0]	r0947[0]
55	40056	1. FAULT	R	-	1	0 - 32767		r0947[1]	r0947[1]
56	40057	2. FAULT	R	-	1	0 - 32767		r0947[2]	r0947[2]
57	40058	3. FAULT	R	-	1	0 - 32767		r0947[3]	r0947[3]
58	40059	WARNING	R	-	1	WARN	OK	ZSW:7	ZSW:7
59	40060	LAST WARNING	R	-	1	0 - 32767		r2110	r2110
60	40061	INVERTER VER	R	-	100	0.00 - 327.67		r0018	r0018
61	40062	DRIVE MODEL	R	-	1	0 - 32767		r0201	r0201
99	40100	STW	R/W	-	1			PZD 1	PZD 1
100	40101	HSW	R/W	-	1			PZD 2	PZD 2
109	40110	ZSW	R	-	1			PZD 1	PZD 1
110	40111	HIW	R	-	1			PZD 2	PZD 2
199	40200	DIGITAL OUT 1	R/W	-	1	HIGH	LOW	r0747.0	(BICO) P0731
200	40201	DIGITAL OUT 2	R/W	-	1	HIGH	LOW	r0747.1	(BICO) P0732
219	40220	ANALOG OUT 1	R	%	100	-100.0 - 100.0		r0774[0]	r0774[0]
239	40240	DIGITAL IN 1	R	-	1	HIGH	LOW	r0722.0	r0722.0
240	40241	DIGITAL IN 2	R	-	1	HIGH	LOW	r0722.1	r0722.1
241	40242	DIGITAL IN 3	R	-	1	HIGH	LOW	r0722.2	r0722.2
242	40243	DIGITAL IN 4	R	-	1	HIGH	LOW	r0722.3	r0722.3
259	40260	ANALOG IN 1	R	%	100	-300.0 - 300.0		r0754[0]	r0754[0]
260	40261	ANALOG IN 2	R	%	100	-300.0 - 300.0		r0754[1]	r0754[1]
299	40300	INVERTER MODEL	R	-	1	0 - 32767		r0201	r0201
300	40301	INVERTER VER	R	-	100	0.00 - 327.67		r0018	r0018

Register No.		Description	Access	Unit	Scaling factor	Range or On/Off text	Read	Write
Inverter	MODBUS							
319	40320	RATED PWR	R	kW	100	0 - 327.67	r0206	r0206
320	40321	CURRENT LMT	R/W	%	10	10.0 - 400.0	P0640	P0640
321	40322	ACCEL TIME	R/W	s	100	0.00 - 650.0	P1120	P1120
322	40323	DECEL TIME	R/W	s	100	0.00 - 650.0	P1121	P1121
323	40324	REF FREQ	R/W	Hz	100	1.00 - 650.0	P2000	P2000
339	40340	REFERENCE	R	Hz	100	-327.68 - 327.67	r0020	r0020
340	40341	SPEED	R	RPM	1	-16250 - 16250	r0022	r0022
341	40342	FREQ OUTPUT	R	Hz	100	-327.68 - 327.67	r0024	r0024
342	40343	OUTPUT VOLTS	R	V	1	0 - 32767	r0025	r0025
343	40344	DC BUS VOLTS	R	V	1	0 - 32767	r0026	r0026
344	40345	CURRENT	R	A	100	0 - 163.83	r0027	r0027
345	40346	TORQUE	R	Nm	100	-325.00 - 325.00	r0031	r0031
346	40347	ACTUAL PWR	R	kW	100	0 - 327.67	r0032	r0032
347	40348	TOTAL KWH	R	kWh	1	0 - 32767	r0039	r0039
348	40349	HAND AUTO	R	-	1	HAND   AUTO	r0807	r0807
399	40400	FAULT 1	R	-	1	0 - 32767	r0947[0]	r0947[0]
400	40401	FAULT 2	R	-	1	0 - 32767	r0947[1]	r0947[1]
401	40402	FAULT 3	R	-	1	0 - 32767	r0947[2]	r0947[2]
402	40403	FAULT 4	R	-	1	0 - 32767	r0947[3]	r0947[3]
403	40404	FAULT 5	R	-	1	0 - 32767	r0947[4]	r0947[4]
404	40405	FAULT 6	R	-	1	0 - 32767	r0947[5]	r0947[5]
405	40406	FAULT 7	R	-	1	0 - 32767	r0947[6]	r0947[6]
406	40407	FAULT 8	R	-	1	0 - 32767	r0947[7]	r0947[7]
407	40408	WARNING	R	-	1	0 - 32767	r2110[0]	r2110[0]
498	40499	PRM ERROR CODE	R	-	1	0 - 254	-	-
499	40500	ENABLE PID	R/W	-	1	0 - 1	r0055.8	(BICO) P2200
500	40501	PID SETP REF	R/W	%	100	-200.0 - 200.0	P2240	P2240
509	40510	LOW PASS	R/W	-	100	0.00 - 60.0	P2265	P2265
510	40511	FEEDBK GAIN	R/W	%	100	0.00 - 500.00	P2269	P2269
511	40512	P GAIN	R/W	-	1000	0.000 - 65.000	P2280	P2280
512	40513	I GAIN	R/W	s	1	0 - 60	P2285	P2285
513	40514	D GAIN	R/W	-	1	0 - 60	P2274	P2274
514	40515	PID UP LMT	R/W	%	100	-200.0 - 200.0	P2291	P2291
515	40516	PID LO LMT	R/W	%	100	-200.0 - 200.0	P2292	P2292
519	40520	PID SETP OUT	R	%	100	-100.0 - 100.0	r2250	r2250
520	40521	PI FEEDBACK	R	%	100	-100.0 - 100.0	r2266	r2266
521	40522	PID OUTPUT	R	%	100	-100.0 - 100.0	r2294	r2294

## Program example

The program below gives an example of calculating the CRC for MODBUS RTU.

```
unsigned int crc_16 (unsigned char *buffer, unsigned int length)
{
    unsigned int i, j, temp_bit, temp_int, crc;
    crc = 0xFFFF;
    for ( i = 0; i < length; i++ )
    {
        temp_int = (unsigned char) *buffer++;
        crc ^= temp_int;
        for ( j = 0; j < 8; j++ )
        {
            temp_bit = crc & 0x0001;
            crc >>= 1;
            if ( temp_bit != 0 )
                crc ^= 0xA001;
        }
    }
}
```

## Parameter scaling

Due to the limits of the integer data in the MODBUS protocol, it is necessary to convert the inverter parameters before transmitting them. This is done by scaling, so that a parameter, which has a position after decimal point, is multiplied by a factor, to get rid of the fractional part. The scaling factor is as defined in the above table.

## BICO parameters

The updating of BICO parameters will also be done in the parameter processing in the background. Because of the limitations of the register value, it is only possible to write a '0' or a '1' to a BICO parameter. This will set BICO input to a static value of either '0' or '1'. The previous connection to another parameter is lost. Reading the BICO parameter will return the current value of the BICO output.

For example: MODBUS register number 40200. Writing a value 0 or 1 to that register will set the BICO input P0731 statically to that value. Reading will return the BICO output, which is stored in r0747.0.

## Fault

The inverter displays the fault F72 when the following three conditions are met:

- The parameter P2014 (USS/MODBUS telegram off time) is not equal to 0.
- Process data has been received from the master since the inverter's start-up.
- The time between receipts of two consecutive process data telegrams exceeds the value of P2014.



## Parameter list

### 7.1 Introduction to parameters

#### Parameter number

Numbers prefixed with an "r" indicate that the parameter is a "read-only" parameter.

Numbers prefixed with a "P" indicate that the parameter is a "writable" parameter.

**[index]** indicates that the parameter is an indexed parameter and specifies the range of indices available. If the index is [0...2] and the meaning is not listed, then see "Data set".

**.0...15** indicates that the parameter has several bits, which can be evaluated or connected individually.

#### Data set

---

##### Note

The "Index" chapter at the end of this manual provides complete lists of CDS/DDS parameters.

---

In the inverter, the parameters which are used to define the sources for commands and setpoints are combined in the **Command Data Set (CDS)**, while the parameters for the open and closed-loop control of the motor are combined in the **Inverter Data Set (DDS)**.

The inverter can be operated from different signal sources by switching over the command data sets. When switching over the inverter data sets, it is possible to switch between different inverter configurations (control type, motor).

Three independent settings are possible for each data set. These settings can be made using the index [0...2] of the particular parameter.

Index	CDS	DDS
[0]	Command data set 0	Inverter data set 0
[1]	Command data set 1	Inverter data set 1
[2]	Command data set 2	Inverter data set 2

SINAMICS V20 has an integrated copy function which is used to transfer data sets. This can be used to copy CDS / DDS parameters corresponding to the particular application.

Copy CDS	Copy DDS	Remarks
P0809[0]	P0819[0]	The data set which is to be copied (source)
P0809[1]	P0819[1]	The data set into which data is to be copied (target)
P0809[2]	P0819[2]	= 1: Start copying
		= 0: Copying completed

7.1 Introduction to parameters

For example, copying of all values from CDS0 to CDS2 can be accomplished by the following procedure:

1. Set P0809[0] = 0: copy from CDS0
2. Set P0809[1] = 2: copy to CDS2
3. Set P0809[2] = 1: start copy

**Command data set**

The command data sets are changed over using the BICO parameters P0810 and P0811, whereby the active command data set is displayed in parameter r0050. Changeover is possible in both the "Ready" and the "Run" states.

P0810 = 0 P0811 = 0	CDS0
P0810 = 1 P0811 = 0	CDS1
P0810 = 0 or 1 P0811 = 1	CDS2

**Inverter data set**

The inverter data sets are changed over using the BICO parameters P0820 and P0821, whereby the active inverter data set is displayed in parameter r0051. Inverter data sets can only be changed over in the "Ready" state.

P0820 = 0 P0821 = 0	DDS0
P0820 = 1 P0821 = 0	DDS1
P0820 = 0 or 1 P0821 = 1	DDS2

**BI, BO, CI, CO, CO/BO in parameter names**

**Note**

The "Index" chapter at the end of this manual provides groups of the BICO parameters.

Certain parameter names include the following abbreviated prefixes: BI, BO, CI, CO and CO/BO followed by a colon. These abbreviations have the following meanings:

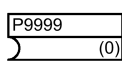
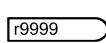
BI	=		Binector input: Parameter selects the source of a binary signal Each BI parameter can connect as the input to any BO or CO/BO parameter.
BO	=		Binector output: Parameter connects as a binary signal Each BO parameter can connect as the output to any BI parameter.



CI	=		Connector input: Parameter selects the source of an analog signal Each CI parameter can connect as the input to any CO or CO/BO parameter.
CO	=		Connector output: Parameter connects as an analog signal Each CO parameter can connect as the output to any CI parameter.
CO/BO	=		Connector/binector output: Parameter connects as an analog signal and/or as a binary signal Each CO/BO parameter can connect as the output to any BI or CI parameter.

### BICO example

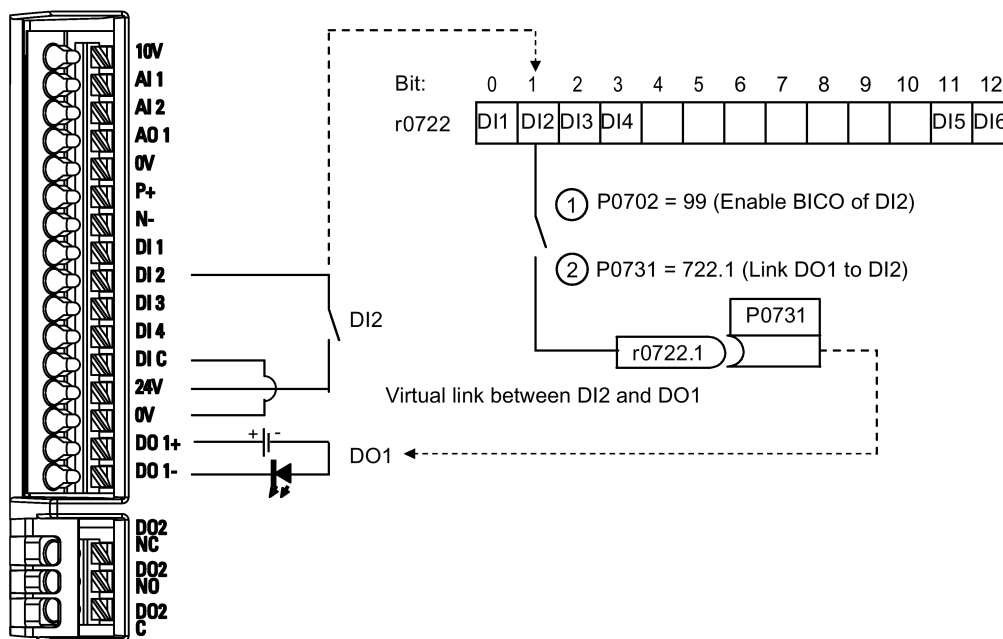

BICO or the binary interconnection technology can help the user to connect internal function and values to realize more customized features.

BICO functionality is a different, more flexible way of setting and combining input and output functions. It can be used in most cases in conjunction with the simple, access level 2 settings.

The BICO system allows complex functions to be programmed. Boolean and mathematical relationships can be set up between inputs (digital, analog, serial etc.) and outputs (inverter current, frequency, analog output, digital outputs, etc.).

The default parameter that a BI or CI parameter is connected to is shown in the Factory default column of the parameter list.

**Access level (P0003)**

Defines the level of user access to parameter sets.

Access level	Description	Remarks
0	User-defined parameter list	Defines a limited set of parameters to which the end user has access. See P0013 for details on use.
1	Standard	Allows access into most frequently used parameters.
2	Extended	Allows extended access to more parameters.
3	Expert	For expert use only.
4	Service	Only for use by authorized service personnel, password protected.

**Data type**

The data types available are shown in the table below.

U8	8-bit unsigned
U16	16-bit unsigned
U32	32-bit unsigned
I16	16-bit integer
I32	32-bit integer
Float	32-bit floating point number

Depending on the data type of the BICO input parameter (signal sink) and BICO output parameter (signal source) the following combinations are possible when creating BICO interconnections:

BICO output parameter	BICO input parameter			BI parameter U32/Bin
	U32/I16	U32/I32	U32/Float	
CO: U8	√	√	-	-
CO: U16	√	√	-	-
CO: U32	√	√	-	-
CO: I16	√	√	-	-
CO: I32	√	√	-	-
CO: Float	√	√	√	-
BO: U8	-	-	-	√
BO: U16	-	-	-	√
BO: U32	-	-	-	√
BO: I16	-	-	-	√
BO: I32	-	-	-	√
BO: Float	-	-	-	-

Legend:  
 √: BICO interconnection permitted  
 -: BICO interconnection not permitted

## Scaling

Specification of the reference quantity with which the signal value will be converted automatically.

Reference quantities, corresponding to 100 %, are required for the statement of physical units as percentages. These reference quantities are entered in P2000 to P2004.

In addition to P2000 to P2004 the following normalizations are used:

- TEMP: 100 °C = 100 %
- PERCENT: 1.0 = 100 %
- 4000H: 4000 hex = 100 %

## Can be changed

Inverter state in which the parameter is changeable. Three states are possible:

- Commissioning: C, C(1) or C(30)
- Run: U
- Ready to run: T

This indicates when the parameter can be changed. One, two or all three states may be specified. If all three states are specified, this means that it is possible to change this parameter setting in all three inverter states. C shows the parameter is changeable whatever P0010 equals; C(1) shows that the parameter is changeable only when P0010 = 1; C(30) shows that the parameter is changeable only when P0010 = 30.

## 7.2 Parameter list

Parameter	Function	Range	Factory default	Can be changed	Scaling	Data set	Data type	Acc. Level
r0002	<b>Inverter state</b>	-	-	-	-	-	U16	2
	Displays actual inverter state.							
	0	Commissioning mode (P0010 ≠ 0)						
	1	Inverter ready						
	2	Inverter fault active						
	3	Inverter starting (visible only while pre-charging DC link)						
	4	Inverter running						
	5	Stopping (ramping down)						
	6	Inverter inhibited						
P0003	<b>User access level</b>	0 - 4	1	U, T	-	-	U16	1
	Defines user access level to parameter sets.							
	0	User defined parameter list - see P0013 for details on use						
	1	Standard: Allows access into most frequently used parameters						
	2	Extended: Allows extended access, for example, to inverter I/O functions						

Parameter list

7.2 Parameter list

Parameter	Function	Range	Factory default	Can be changed	Scaling	Data set	Data type	Acc. Level
	3	Expert: For expert use only						
	4	Service: Only for use by authorized service, password protected						
P0004	<b>Parameter filter</b>	0 - 24	0	U, T	-	-	U16	1
	Filters parameters according to functionality to enable a more focused approach to commissioning.							
	0	All parameters						
	2	Inverter						
	3	Motor						
	5	Technology application / units						
	7	Commands, binary I/O						
	8	Analog input and analog output						
	10	Setpoint channel / RFG						
	12	Inverter features						
	13	Motor control						
	19	Motor identification						
	20	Communication						
	21	Warnings / faults / monitoring						
	22	Technology controller						
	24	List of modified parameters						
P0007	<b>Backlight delay time</b>	0 - 2000	0	U, T	-	-	U16	3
	Defines time period after which the backlight of the operator panel display turns off if no buttons have been pressed.							
	0	Backlight always on						
	1 - 2000	Number of seconds after which the backlight turns off.						
P0010	<b>Commissioning parameter</b>	0 - 30	0	T	-	-	U16	1
	Filters parameters so that only those related to a particular functional group are selected.							
	0	Ready						
	1	Quick commissioning						
	2	Inverter						
	29	Download						
	30	Factory setting						
<b>Dependency:</b>	Reset to 0 for inverter to run. P0003 (user access level) also determines access to parameters.							

Parameter	Function	Range	Factory default	Can be changed	Scaling	Data set	Data type	Acc. Level
<b>Note:</b>	<ul style="list-style-type: none"> <li>• P0010 = 1 The inverter can be commissioned very quickly and easily by setting P0010 = 1. After that only the important parameters (e.g.: P0304, P0305, etc.) are visible. The value of these parameters must be entered one after the other. The end of quick commissioning and the start of internal calculation will be done by setting P3900 = 1 - 3. Afterwards parameter P0010 and P3900 will be reset to zero automatically.</li> <li>• P0010 = 2 For service purposes only.</li> <li>• P0010 = 30 When resetting the parameters or user default values of inverter P0010 must be set to 30. Resetting of the parameters will be started by setting parameter P0970 = 1. The inverter will automatically reset all its parameters to their default settings. This can prove beneficial if you experience problems during parameter setup and wish to start again. Resetting of the user default values will be started by setting parameter P0970 = 21. The inverter will automatically reset all its parameters to the factory default settings. Duration of factory setting will take about 60 seconds.</li> </ul>							
P0011	<b>Lock for user-defined parameter</b>	0 - 65535	0	U, T	-	-	U16	3
	See P0013							
P0012	<b>Key for user-defined parameter</b>	0 - 65535	0	U, T	-	-	U16	3
	See P0013							
P0013[0...19]	<b>User-defined parameter</b>	0 - 65535	[0...16] 0 [17] 3 [18] 10 [19] 12	U, T	-	-	U16	3
	<p>Defines a limited set of parameters to which the end user has access.</p> <p><b>Instructions for use:</b></p> <ol style="list-style-type: none"> <li>1. Set P0003 = 3 (expert user).</li> <li>2. Go to P0013 indices 0 to 16 (user list)</li> <li>3. Enter into P0013 index 0 to 16 the parameters required to be visible in the user-defined list. The following values are fixed and cannot be changed: <ul style="list-style-type: none"> <li>- P0013 index 17 = 3 (user access level)</li> <li>- P0013 index 18 = 10 (commissioning parameter filter)</li> <li>- P0013 index 19 = 12 (key for user defined parameter)</li> </ul> </li> <li>4. Set P0003 = 0 to activate the user defined parameter.</li> </ol>							
<b>Index:</b>	[0]	1st user parameter						
	[1]	2nd user parameter						
	...	...						
	[19]	20th user parameter						

7.2 Parameter list

Parameter	Function	Range	Factory default	Can be changed	Scaling	Data set	Data type	Acc. Level
<b>Dependency:</b>	First, set P0011 ("lock") to a different value then P0012 ("key") to prevent changes to user-defined parameter. Then, set P0003 to 0 to activate the user-defined list. When locked and the user-defined parameter is activated, the only way to exit the user-defined parameter (and view other parameters) is to set P0012 ("key") to the value in P0011 ("lock").							
P0014[0...2]	<b>Store mode</b>	0 - 1	0	U, T	-	-	U16	3
	Sets the store mode for parameters. The store mode can be configured for all interfaces under "Index".							
	0	Volatile ( RAM)						
	1	Non-volatile (EEPROM)						
<b>Index:</b>	[0]	USS/Modbus on RS485						
	[1]	USS on RS232 (reserved)						
	[2]	Reserved						
<b>Note:</b>	An independent store request may be part of the serial communications (for example, PKE bits 15-12 of USS protocol). See the table below for an influence on the settings of P0014.							
	<b>Value of P0014 [x]</b>	<b>Store request via USS</b>				<b>Result</b>		
	RAM	EEPROM				EEPROM		
	EEPROM	EEPROM				EEPROM		
	RAM	RAM				RAM		
	EEPROM	RAM				EEPROM		
	1. P0014 itself will always be stored in the EEPROM. 2. P0014 will not be changed by performing a factory reset (P0010 = 30 and P0970 = 1).  When transferring parameter P0014, the inverter uses its processor to carry-out internal calculations. Communications - both via USS as well as Modbus - are interrupted for the time that it takes to make these calculations.							
r0018	<b>Firmware version</b>	-	-	-	-	-	Float	1
	Displays version number of installed firmware.							
r0019.0...14	<b>CO / BO: Operator panel control word</b>	-	-	-	-	-	U16	3
	Displays status of operator panel commands. The settings below are used as the "source" codes for keypad control when connecting to BICO input parameters.							
	<b>Bit</b>	<b>Signal name</b>			<b>1 signal</b>		<b>0 signal</b>	
	00	ON / OFF1			Yes		No	
	01	OFF2: Electrical stop			No		Yes	
	08	JOG right			Yes		No	
	11	Reverse (setpoint inversion)			Yes		No	
	13	Motor potentiometer MOP up			Yes		No	
	14	Motor potentiometer MOP down			Yes		No	
<b>Note:</b>	When BICO technology is used to allocate functions to panel buttons, this parameter displays the actual status of the relevant command.							
r0020	<b>CO: Frequency setpoint before RFG [Hz]</b>	-	-	-	-	-	Float	3
	Displays actual frequency setpoint (input of ramp function generator). This value is available filtered (r0020) and unfiltered (r1119). The actual frequency setpoint after RFG is displayed in r1170.							

Parameter	Function	Range	Factory default	Can be changed	Scaling	Data set	Data type	Acc. Level
r0021	<b>CO: Actual filtered frequency [Hz]</b>	-	-	-	-	-	Float	2
	Displays actual inverter output frequency (r0024) excluding slip compensation (and resonance damping, frequency limitation in V/f mode).							
r0022	<b>Actual filtered rotor speed [RPM]</b>	-	-	-	-	-	Float	3
	Displays calculated rotor speed based on r0021 (filtered output frequency [Hz] x 120 / number of poles). The value is updated every 128 ms.							
<b>Note:</b>	This calculation makes no allowance for load-dependent slip.							
r0024	<b>CO: Actual filtered output frequency [Hz]</b>	-	-	-	-	-	Float	3
	Displays actual filtered output frequency (slip compensation, resonance damping and frequency limitation are included). See also r0021. This value is available filtered (r0024) and unfiltered (r0066).							
r0025	<b>CO: Actual output voltage [V]</b>	-	-	-	-	-	Float	2
	Displays filtered [rms] voltage applied to motor. This value is available filtered (r0025) and unfiltered (r0072).							
r0026[0]	<b>CO: Actual filtered DC-link voltage [V]</b>	-	-	-	-	-	Float	2
	Displays filtered DC-link voltage. This value is available filtered (r0026) and unfiltered (r0070).							
<b>Index:</b>	[0]	Compensation DC voltage channel						
<b>Note:</b>	r0026[0] = Main DC-link voltage							
r0027	<b>CO: Actual output current [A]</b>	-	-	-	P2002	-	Float	2
	Displays rms value of motor current. This value is available filtered (r0027) and unfiltered (r0068).							
r0028	<b>CO: Motor current modulus</b>	-	-	-	P2002	-	Float	4
	Displays estimated rms value of motor current calculated from dclink current.							
r0031	<b>CO: Actual filtered torque [Nm]</b>	-	-	-	-	-	Float	2
	Displays electrical torque. This value is available filtered (r0031) and unfiltered (r0080).							
<b>Note:</b>	The electrical torque is not the same as the mechanical torque, which can be measured on the shaft. Due to windage and friction a part of the electrical torque is lost in the motor.							
r0032	<b>CO: Actual filtered power</b>	-	-	-	r2004	-	Float	2
	Displays (mechanical) shaft power. Value is displayed in [kW] or [hp] depending on setting for P0100 (operation for Europe / North America). $P_{mech} = 2 * \pi * f * M \rightarrow$ $r0032[kW] = (2 * \pi / 1000) * (r0022 / 60)[1 / min] * r0031[Nm]$ $r0032[hp] = r0032[kW] / 0.75$							
r0035[0...2]	<b>CO: Actual motor temperature [°C]</b>	-	-	-	-	DDS	Float	2
	Displays calculated motor temperature.							
r0036	<b>CO: Inverter overload utilization [%]</b>	-	-	-	PERCENT	-	Float	3

Parameter list

7.2 Parameter list

Parameter	Function	Range	Factory default	Can be changed	Scaling	Data set	Data type	Acc. Level
	Displays inverter overload utilization calculated via the I <sup>2</sup> t model. The actual I <sup>2</sup> t value relative to the maximum possible I <sup>2</sup> t value supplies utilization in [%]. If the current exceeds the threshold for P0294 (inverter I <sup>2</sup> t overload warning), warning A505 (inverter I <sup>2</sup> t) is generated and the output current of the inverter reduced via P0290 (inverter overload reaction). If 100 % utilization is exceeded, fault F5 (inverter I <sup>2</sup> t) is tripped.							
r0037[0...1]	<b>CO: Inverter temperature [°C]</b>	-	-	-	-	-	Float	3
	Displays measured heat sink temperature and calculated junction temperature of IGBTs based on thermal model.							
<b>Index:</b>	[0]	Measured heat sink temperature						
	[1]	Total Chip Junction Temperature						
<b>Note:</b>	The values are updated every 128 ms.							
r0038	<b>CO: Filtered power factor</b>	-	-	-	-	-	Float	3
	Displays the filtered power factor.							
r0039	<b>CO: Energy consumption meter [kWh]</b>	-	-	-	-	-	Float	2
	Displays electrical energy used by inverter since display was last reset (see P0040 - reset energy consumption meter).							
<b>Dependency:</b>	Value is reset when P0040 = 1 (reset energy consumption meter).							
P0040	<b>Reset energy consumption and energy saved meter</b>	0 - 1	0	T	-	-	U16	2
	Resets value of r0039 (energy consumption meter) and r0043 (energy saved meter) to zero.							
	0	No reset						
	1	Reset r0039 to 0						
P0042[0...1]	<b>Energy saving scaling</b>	0.000 - 100.00	0.000	T	-	-	Float	2
	Scales the calculated energy saved value							
<b>Index:</b>	[0]	Factor for kWh to currency conversion						
	[1]	Factor for kWh to CO <sub>2</sub> conversion						
r0043[0...2]	<b>Energy saved [kWh]</b>	-	-	-	-	-	Float	2
	Displays calculated energy saved							
<b>Index:</b>	[0]	Energy saving in kWh						
	[1]	Energy saving in currency						
	[2]	Energy saving in CO <sub>2</sub>						
r0050	<b>CO / BO: Active command data set</b>	-	-	-	-	-	U16	2
	Displays currently active command data set.							
	0	Command data set 0 (CDS)						
	1	Command data set 1 (CDS)						
	2	Command data set 2 (CDS)						
<b>Note:</b>	See P0810							



Parameter	Function	Range	Factory default	Can be changed	Scaling	Data set	Data type	Acc. Level
r0051[0...1]	<b>CO: Active inverter data set (DDS)</b>	-	-	-	-	-	U16	2
	Displays currently selected and active inverter data set (DDS).							
	0	Inverter data set 0 (DDS0)						
	1	Inverter data set 1 (DDS1)						
	2	Inverter data set 2 (DDS2)						
<b>Index:</b>	[0]	Selected inverter data set						
	[1]	Active inverter data set						
<b>Note:</b>	See P0820							
r0052.0...15	<b>CO / BO: Active status word 1</b>	-	-	-	-	-	U16	2
	Displays first active status word of inverter (bit format) and can be used to diagnose inverter status.							
	<b>Bit</b>	<b>Signal name</b>			<b>1 signal</b>	<b>0 signal</b>		
	00	Inverter ready			Yes	No		
	01	Inverter ready to run			Yes	No		
	02	Inverter running			Yes	No		
	03	Inverter fault active			Yes	No		
	04	OFF2 active			No	Yes		
	05	OFF3 active			No	Yes		
	06	ON inhibit active			Yes	No		
	07	Inverter warning active			Yes	No		
	08	Deviation setpoint / act. value			No	Yes		
	09	PZD control			Yes	No		
	10	f_act  >= P1082 (f_max)			Yes	No		
	11	Warning: Motor current / torque limit			No	Yes		
	12	Brake open			Yes	No		
	13	Motor overload			No	Yes		
	14	Motor runs right			Yes	No		
	15	Inverter overload			No	Yes		
<b>Dependency:</b>	r0052 bit 03 "Inverter fault active": Output of bit 3 (Fault) will be inverted on digital output (Low = Fault, High = No Fault); r0052 bit 06 "On inhibit" is active with OFF2 or OFF3 and becomes disabled with OFF1, NOT OFF2 and NOT OFF3.							
<b>Note:</b>	See r2197 and r2198.							
r0053.0...15	<b>CO / BO: Active status word 2</b>	-	-	-	-	-	U16	2
	Displays second status word of inverter (in bit format).							
	<b>Bit</b>	<b>Signal name</b>			<b>1 signal</b>	<b>0 signal</b>		
	00	DC brake active			Yes	No		
	01	f_act  > P2167 (f_off)			Yes	No		
	02	f_act  > P1080 (f_min)			Yes	No		
	03	Act. current  r0068  >= P2170			Yes	No		

Parameter list

7.2 Parameter list

Parameter	Function	Range	Factory default	Can be changed	Scaling	Data set	Data type	Acc. Level
	04	f_act  > P2155 (f_1)			Yes		No	
	05	f_act  <= P2155 (f_1)			Yes		No	
	06	f_act >= setpoint (f_set)			Yes		No	
	07	Act. unfilt. Vdc < P2172			Yes		No	
	08	Act. unfilt. Vdc > P2172			Yes		No	
	09	Ramping finished			Yes		No	
	10	PID output r2294 == P2292 (PID_min)			Yes		No	
	11	PID output r2294 == P2291 (PID_max)			Yes		No	
	14	Download Data set 0 from external storage			Yes		No	
	15	Download Data set 1 from external storage			Yes		No	
<b>Notice:</b>	r0053 bit 00 "DC brake active" ==> see P1233							
<b>Note:</b>	See r2197 and r2198. Bit 14 and 15 are existing for consistency reasons with SINAMICS G120.							
r0054.0...15	<b>CO / BO: Active control word 1</b>	-	-	-	-	-	U16	3
	Displays first control word of inverter (in bit format) and can be used to diagnose which commands are active.							
	<b>Bit</b>	<b>Signal name</b>			<b>1 signal</b>		<b>0 signal</b>	
	00	ON / OFF1			Yes		No	
	01	OFF2: electrical stop			No		Yes	
	02	OFF3: fast stop			No		Yes	
	03	Pulse enable			Yes		No	
	04	RFG enable			Yes		No	
	05	RFG start			Yes		No	
	06	Setpoint enable			Yes		No	
	07	Fault acknowledge			Yes		No	
	08	JOG right			Yes		No	
	09	JOG left			Yes		No	
	10	Control from PLC			Yes		No	
	11	Reverse (setpoint inversion)			Yes		No	
	13	Motor potentiometer MOP up			Yes		No	
	14	Motor potentiometer MOP down			Yes		No	
	15	CDS Bit 0 (Hand / Auto)			Yes		No	
<b>Notice:</b>	r0054 is identical to r2036 if USS is selected as command source via P0700 or P0719.							
r0055.0...15	<b>CO / BO: Active control word 2</b>	-	-	-	-	-	U16	3
	Displays additional control word of inverter (in bit format) and can be used to diagnose which commands are active.							
	<b>Bit</b>	<b>Signal name</b>			<b>1 signal</b>		<b>0 signal</b>	
	00	Fixed frequency Bit 0			Yes		No	
	01	Fixed frequency Bit 1			Yes		No	
	02	Fixed frequency Bit 2			Yes		No	

Parameter	Function	Range	Factory default	Can be changed	Scaling	Data set	Data type	Acc. Level
	03	Fixed frequency Bit 3			Yes		No	
	04	Inverter data set (DDS) Bit 0			Yes		No	
	05	Inverter data set (DDS) Bit 1			Yes		No	
	06	Quick stop disable			Yes		No	
	08	Enable PID			Yes		No	
	09	Enable DC brake			Yes		No	
	13	External fault 1			No		Yes	
	15	Command data set (CDS) Bit 1			Yes		No	
<b>Notice:</b>	r0055 is identical to r2037 if USS is selected as command source via P0700 or P0719.							
r0056.0...15	<b>CO / BO: Status of motor control</b>	-	-	-	-	-	U16	3
	Displays status of motor control (in bit format), which can be used to diagnose inverter status.							
	<b>Bit</b>	<b>Signal name</b>			<b>1 signal</b>	<b>0 signal</b>		
	00	Init. control finished			Yes	No		
	01	Motor demagnetizing finished			Yes	No		
	02	Pulses enabled			Yes	No		
	03	Voltage soft start select			Yes	No		
	04	Motor excitation finished			Yes	No		
	05	Starting boost active			Yes	No		
	06	Acceleration boost active			Yes	No		
	07	Frequency is negative			Yes	No		
	08	Field weakening active			Yes	No		
	09	Volts setpoint limited			Yes	No		
	10	Slip frequency limited			Yes	No		
	11	f_out > f_max Freq. limited			Yes	No		
	12	Phase reversal selected			Yes	No		
	13	Imax controller active / torque limit reached			Yes	No		
	14	Vdc_max controller active			Yes	No		
	15	KIB (Vdc_min control) active			Yes	No		
<b>Notice:</b>	The I-max controller (r0056 bit 13) will be activated when the actual output current (r0027) exceeds the current limit in r0067.							
r0066	<b>CO: Actual output frequency [Hz]</b>	-	-	-	-	-	Float	3
	Displays actual output frequency in Hz. This value is available filtered (r0024) and unfiltered (r0066).							
<b>Note:</b>	The output frequency is limited by the values entered in P1080 (minimum frequency) and P1082 (maximum frequency).							
r0067	<b>CO: Actual output current limit [A]</b>	-	-	-	P2002	-	Float	3

7.2 Parameter list

Parameter	Function	Range	Factory default	Can be changed	Scaling	Data set	Data type	Acc. Level
	Displays valid maximum output current of inverter. r0067 is influenced/determined by the following factors: <ul style="list-style-type: none"> <li>• Inverter application P0205</li> <li>• Rated motor current P0305</li> <li>• Motor overload factor P0640</li> <li>• Motor protection in dependency of P0610</li> <li>• r0067 is less than or equal to maximum inverter current r0209</li> <li>• Inverter protection in dependency of P0290</li> </ul>							
<b>Note:</b>	A reduction of r0067 may indicate an inverter overload or a motor overload.							
r0068	<b>CO: Output current [A]</b>	-	-	-	P2002	-	Float	3
	Displays unfiltered [rms] value of motor current. This value is available filtered (r0027) and unfiltered (r0068).							
<b>Note:</b>	Used for process control purposes (in contrast to r0027, which is filtered and is used to display the value through USS).							
r0069[0...5]	<b>CO: Actual phase currents [A]</b>	-	-	-	P2002	-	Float	4
	Displays measured phase currents.							
<b>Index:</b>	[0]	U_Phase / Emitter1/						
	[1]	Dclink / Emitter2						
	[2]	Dclink						
	[3]	Offset U_phase / Emitter						
	[4]	Offset dclink						
	[5]	Not used						
r0070	<b>CO: Actual DC-link voltage [V]</b>	-	-	-	-	-	Float	3
	Displays DC-link voltage. This value is available filtered (r0026) and unfiltered (r0070).							
<b>Note:</b>	Used for process control purposes (in contrast to r0026 (actual DC-link voltage), which is filtered).							
r0071	<b>CO: Maximum output voltage [V]</b>	-	-	-	-	-	Float	3
	Displays maximum output voltage.							
<b>Dependency:</b>	Actual maximum output voltage depends on the actual input supply voltage.							
r0072	<b>CO: Actual output voltage [V]</b>	-	-	-	-	-	Float	3
	Displays output voltage. This value is available filtered (r0025) and unfiltered (r0072).							
r0074	<b>CO: Actual modulation [%]</b>	-	-	-	PERCENT	-	Float	4
	Displays actual modulation index. The modulation index is defined as ratio between the magnitude of the fundamental component in the inverter phase output voltage and half of the DC-link voltage.							
r0078	<b>CO: Actual current Isq [A]</b>	-	-	-	P2002	-	Float	3
	Displays component of torque generating current. This value is available filtered (r0030) and unfiltered (r0078).							

Parameter	Function	Range	Factory default	Can be changed	Scaling	Data set	Data type	Acc. Level
r0080	<b>CO: Actual torque [Nm]</b>	-	-	-	-	-	Float	4
	Displays actual torque. This value is available filtered (r0031) and unfiltered (r0080).							
r0084	<b>CO: Actual air gap flux [%]</b>	-	-	-	PERCENT	-	Float	4
	Displays air gap flux relative to the rated motor flux.							
r0085	<b>CO: Actual re-active current [A]</b>	-	-	-	P2002	-	Float	3
	Displays re-active (imaginary part) of motor current.							
<b>Dependency:</b>	Applies when V/f control is selected in P1300 (control mode); otherwise, the display shows the value zero.							
r0086	<b>CO: Actual active current [A]</b>	-	-	-	P2002	-	Float	3
	Displays active (real part) of motor current.							
<b>Dependency:</b>	See r0085							
r0087	<b>CO: Actual power factor</b>	-	-	-	-	-	Float	3
	Displays the actual power factor.							
r0094	<b>CO: Transformation angle [°]</b>	-	0.0	-	4000H	-	Float	3
	Displays the transformation angle (flux angle in VC mode or angle from frequency in Vf mode).							
P0095[0...9]	<b>CI: Display PZD signals</b>	0 - 4294967295	0	T	4000H	-	U32	3
	Selects source of display for PZD signals.							
<b>Index:</b>	[0]	1st PZD signal						
	[1]	2nd PZD signal						
	...	...						
	[9]	10th PZD signal						
r0096[0...9]	<b>PZD signals [%]</b>	-	-	-	-	-	Float	3
	Displays PZD signals.							
<b>Index:</b>	[0]	1st PZD signal						
	[1]	2nd PZD signal						
	...	...						
	[9]	10th PZD signal						
<b>Note:</b>	r0096 = 100 % corresponds to 4000 hex.							
P0100	<b>Europe / North America</b>	0 - 2	0	C(1)	-	-	U16	1
	Determines whether the power settings are expressed in [kW] or [hp] (e.g. Rated motor power P0307). The default settings for the rated motor frequency P0310 and maximum frequency P1082 are set automatically here, in addition to reference frequency P2000.							
	0	Europe [kW], motor base frequency is 50 Hz						
	1	North America [hp], motor base frequency is 60 Hz						
	2	North America [kW], motor base frequency is 60 Hz						

7.2 Parameter list

Parameter	Function	Range	Factory default	Can be changed	Scaling	Data set	Data type	Acc. Level
<b>Dependency:</b>	Where: <ul style="list-style-type: none"> <li>• Stop inverter first (i.e. disable all pulses) before you change this parameter.</li> <li>• P0100 can only be changed with P0010 = 1 (Commissioning mode) via the respective interface (for example, USS).</li> <li>• Changing P0100 resets all rated motor parameters as well as other parameters that depend on the rated motor parameters (see P0340 - calculation of motor parameters).</li> </ul>							
r0191[0...2]	<b>Configuration inverter</b>	-	0	-	-	-	U32	3
	Displays the actual hardware configuration (SZL vector) of the inverter.							
<b>Index:</b>	[0]	SZL vector of inverter and power module						
	[1]	SZL vector of inverter						
	[2]	SZL vector of power module						
P0199	<b>Equipment system number</b>	0 - 255	0	U, T	-	-	U16	4
	Equipment system number. This parameter has no operation effect (only for factory purposes).							
P0201[0...2]	<b>Actual power module code number</b>	0 - 65535	0	T	-	-	U16	3
	Identifies hardware variant.							
<b>Index:</b>	[0]	Inverter code						
	[1]	Functionality version - last digit of MLFB						
	[2]	Last used inverter ID						
<b>Notice:</b>	Parameter P0201 = 0 indicates that no power module has been identified.							
r0204	<b>Power module features</b>	-	0	-	-	-	U32	3
	Displays hardware features of power module.							
	<b>Bit</b>	<b>Signal name</b>			<b>1 signal</b>		<b>0 signal</b>	
	00	DC input voltage			Yes		No	
	01	RFI filter			Yes		No	
	02	Active line module			Yes		No	
	03	SLM			Yes		No	
	04	BLM with thyristor			Yes		No	
	05	BLM with diode			Yes		No	
	06	Water cooled			Yes		No	
	07	F3E inverter			Yes		No	
	12	Safe brake			Yes		No	
	13	Safety enabled			Yes		No	
	14	Integrated output filter			Yes		No	
<b>Note:</b>	Parameter r0204 = 0 indicates that no power module has been identified.							
P0205	<b>Inverter application</b>	0 - 1	0	C1	-	-	U16	3

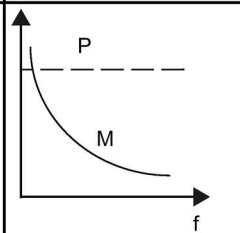
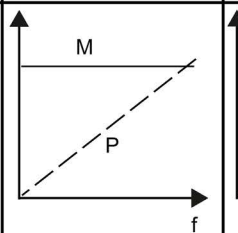
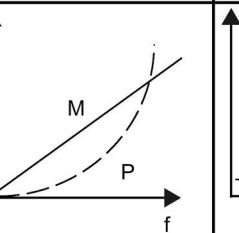
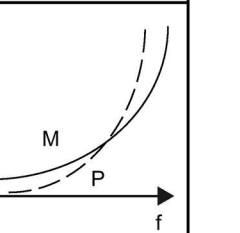
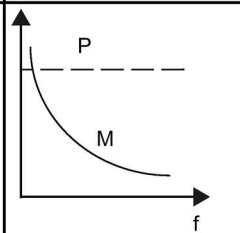
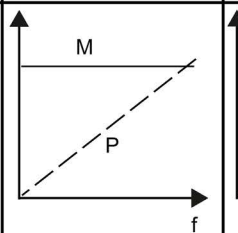
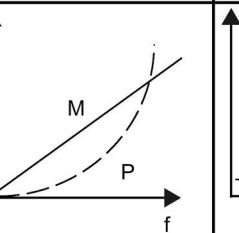
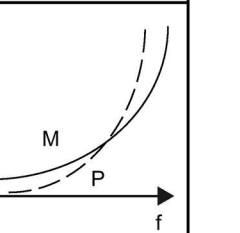
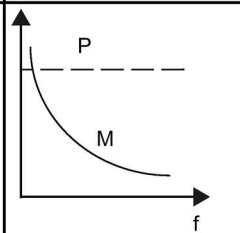
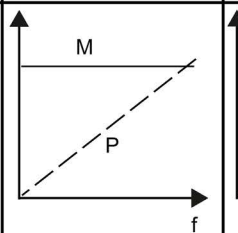
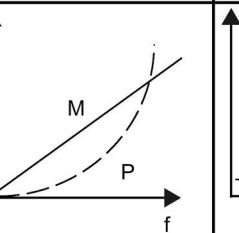
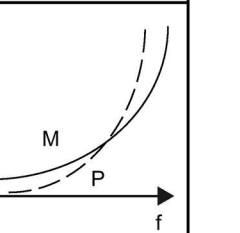
Parameter	Function	Range	Factory default	Can be changed	Scaling	Data set	Data type	Acc. Level																				
	<p>Selects inverter application.</p> <p>The inverter and motor requirements are determined by the speed range and torque requirements of the load. The relationship between speed and torque for different loads (high overloads or low overloads) is shown in the following figure:</p> <table border="1" style="width: 100%; border-collapse: collapse;"> <tr> <td>Torque</td> <td><math>M \sim \frac{1}{f}</math></td> <td><math>M = \text{const.}</math></td> <td><math>M \sim f</math></td> <td><math>M \sim f^2</math></td> </tr> <tr> <td>Power</td> <td><math>p = \text{const.}</math></td> <td><math>p \sim f</math></td> <td><math>p \sim f^2</math></td> <td><math>p \sim f^3</math></td> </tr> <tr> <td>Characteristic</td> <td></td> <td></td> <td></td> <td></td> </tr> <tr> <td>Application</td> <td>Winders Facing lathes Rotary cutting machines</td> <td>Hoisting gear Belt conveyors Process machines involving forming Rolling mills Planers Compressors</td> <td>Calenders with viscous friction Eddy-current brakes</td> <td>Pumps Fans Centrifuges</td> </tr> </table>								Torque	$M \sim \frac{1}{f}$	$M = \text{const.}$	$M \sim f$	$M \sim f^2$	Power	$p = \text{const.}$	$p \sim f$	$p \sim f^2$	$p \sim f^3$	Characteristic					Application	Winders Facing lathes Rotary cutting machines	Hoisting gear Belt conveyors Process machines involving forming Rolling mills Planers Compressors	Calenders with viscous friction Eddy-current brakes	Pumps Fans Centrifuges
Torque	$M \sim \frac{1}{f}$	$M = \text{const.}$	$M \sim f$	$M \sim f^2$																								
Power	$p = \text{const.}$	$p \sim f$	$p \sim f^2$	$p \sim f^3$																								
Characteristic																												
Application	Winders Facing lathes Rotary cutting machines	Hoisting gear Belt conveyors Process machines involving forming Rolling mills Planers Compressors	Calenders with viscous friction Eddy-current brakes	Pumps Fans Centrifuges																								
	<ul style="list-style-type: none"> <li>High overload (HO):</li> </ul> <p>HO mode is used if the application needs a high overload on the whole frequency range. Many loads can be considered to be high overloads. Typical high overloads are conveyors, compressors and positive displacement pumps.</p> <ul style="list-style-type: none"> <li>Low overload (LO):</li> </ul> <p>LO mode is used if the application has a parabolic frequency/torque characteristic like many fans and pumps. Low overload offers the following possibilities with the same inverter:</p> <ul style="list-style-type: none"> <li>Higher rated inverter current r0207</li> <li>Higher rated inverter power r0206</li> <li>Higher threshold for I2t protection</li> </ul> <p>If P0205 is modified in quick commissioning it immediately calculates various motor parameters:</p> <ul style="list-style-type: none"> <li>P0305 Rated motor current</li> <li>P0307 Rated motor power</li> <li>P0640 Motor overload factor</li> </ul> <p>It is recommended to modify P0205 first. Afterwards motor parameter may be adapted.</p> <p>Motor parameter will be overridden by changing this sequence.</p>																											
<b>Values:</b>	0	High overload																										
	1	Low overload																										

7.2 Parameter list

Parameter	Function	Range	Factory default	Can be changed	Scaling	Data set	Data type	Acc. Level
<b>Notice:</b>	Use setting 1 (low overload) only for low-overload applications (for example, pumps and fans). If it is used for high-overload applications, I2t warning will be produced too late, causing overheating in the motor.							
<b>Note:</b>	This parameter selects inverter application for FSE only. The parameter value is not reset by the factory setting (see P0970).							
r0206	<b>Rated inverter power [kW] / [hp]</b>	-	-	-	-	-	Float	2
	Displays nominal rated motor power from inverter.							
<b>Dependency:</b>	Value is displayed in [kW] or [hp] depending on setting for P0100 (operation for Europe / North America).							
r0207[0...2]	<b>Rated inverter current [A]</b>	-	-	-	-	-	Float	2
	Displays rated inverter current.							
<b>Index:</b>	[0]	Rated inverter current						
	[1]	Rated LO current						
	[2]	Rated HO current						
<b>Note:</b>	<p>The rated high overload (HO) current r0207[2] values correspond to suitable 4-pole Siemens standard motors (IEC) for the selected load cycle (see diagram). r0207[2] is the default value of P0305 in association with the HO application (load cycle).</p> <p>Inverter current / power %</p> <p>150% r0209</p> <p>100% r0207[0]</p> <p>94.5%</p> <p>Rated inverter current (continuous)</p> <p>Base load current (with overload capability)</p> <p>Short-time current</p> <p>60 s</p> <p>240 s</p> <p>t</p>							
r0208	<b>Rated inverter voltage [V]</b>	-	-	-	-	-	U32	2
	Displays nominal AC supply voltage of inverter.							
<b>Note:</b>	<p>r0208 = 230: 200 V to 240 V (tolerance: -10% to +10%)</p> <p>r0208 = 400: 380 V to 480 V (tolerance: -15% to +10%)</p>							



Parameter	Function	Range	Factory default	Can be changed	Scaling	Data set	Data type	Acc. Level
r0209	<b>Maximum inverter current [A]</b>	-	-	-	-	-	Float	2
	Displays maximum output current of inverter.							
<b>Dependency:</b>	r0209 depends on the derating which is affected by pulse frequency P1800, surrounding temperature and altitude. The data of deration is given in the Operating Instructions.							
P0210	<b>Supply voltage [V]</b>	380 - 480	400	T	-	-	U16	3
	P0210 defines the supply voltage. Its default value depends upon the type of inverter. If P0210 does not correspond to the supply voltage, then it must be modified.							
<b>Dependency:</b>	<p>Optimizes Vdc controller, which extends the ramp-down time if regenerative energy from motor would otherwise cause DC-link overvoltage trips.</p> <p>Reducing the value enables controller to cut in earlier and reduce the risk of overvoltage.</p> <p>Set P1254 ("Auto detect Vdc switch-on levels") = 0. Cut-in levels for Vdc controller and compound braking are then derived directly from P0210 (supply voltage):</p> <ul style="list-style-type: none"> <li>Vdc_min switch-on level (r1246) = <math>P1245 * \sqrt{2} * P0210</math></li> <li>Vdc_max switch-on level (r1242) = <math>1.15 * \sqrt{2} * P0210</math></li> <li>Dynamic braking switch-on level = <math>1.13 * \sqrt{2} * P0210</math></li> <li>Compound braking switch-on level = <math>1.13 * \sqrt{2} * P0210</math></li> </ul> <p>Set P1254 ("Auto detect Vdc switch-on levels") = 1. Cut-in levels for Vdc controller and compound braking are then derived from r0070 (DC-link voltage):</p> <ul style="list-style-type: none"> <li>Vdc_min switch-on level (r1246) = <math>P1245 * r0070</math></li> <li>Vdc_max switch-on level (r1242) = <math>1.15 * r0070</math></li> <li>Dynamic braking switch-on level = <math>0.98 * r1242</math></li> <li>Compound braking switch-on level = <math>0.98 * r1242</math></li> </ul> <p>Auto-detection calculations are only performed when the inverter has been in standby for over 20s. When pulses are enabled, the calculated values are frozen until 20s after pulses cease.</p>							
<b>Note:</b>	<p>For best results, it is recommended that auto-detection of Vdc switch-on levels (P1254 = 1) is used. Setting P1254 = 0 is only recommended when there is a high degree of fluctuation of the DC-link when the motor is being driven. In this case, ensure the setting of P0210 is correct.</p> <p>If mains voltage is higher than value entered, automatic deactivation of the Vdc controller may occur to avoid acceleration of the motor. A warning will be issued in this case (A910).</p> <p>Default value is depending on inverter type and its rating data.</p>							
r0231[0...1]	<b>Maximum cable length [m]</b>	-	-	-	-	-	U16	3
	Indexed parameter to display maximum allowable cable length between inverter and motor.							
<b>Index:</b>	[0]	Maximum allowed unscreened cable length						
	[1]	Maximum allowed screened cable length						
<b>Notice:</b>	For full EMC compliance, the screened cable must not exceed 25 m in length when an EMC filter is fitted.							
P0290	<b>Inverter overload reaction</b>	0 - 3	2	T	-	-	U16	3
	Selects reaction of inverter to an internal thermal overload condition.							
	0	Reduce output frequency and output current						
	1	No reduction, trip (F4 / 5/ 6) when thermal limits reached						
	2	Reduce pulse frequency, output current and output frequency						

Parameter	Function	Range	Factory default	Can be changed	Scaling	Data set	Data type	Acc. Level
	3	Reduce pulse frequency only and trip (F6) when overload too high						
<b>Dependency:</b>	<p>Following physical values influence the inverter overload protection (see diagram):</p> <ul style="list-style-type: none"> <li>Heat sink temperature (r0037[0]); causes A504 and F4.</li> <li>IGBT Junction temperature (r0037[1]); causes F4 or F6.</li> <li>Delta temperature between heat sink and junction temperature; causes A504 and F6.</li> <li>Inverter I<sup>2</sup>t (r0036); causes A505 and F5.</li> </ul>							
<b>Notice:</b>	<p>P0290 = 0, 2:</p> <ul style="list-style-type: none"> <li>Reduction of output frequency is only effective if the load is also reduced. This is for example valid for light overload applications with a quadratic torque characteristic as pumps or fans.</li> <li>For settings P0290 = 0 or 2, the I-max controller will act upon the output current limit (r0067) in case of overtemperature.</li> </ul> <p>P0290 = 0:</p> <ul style="list-style-type: none"> <li>With pulse frequencies above nominal, pulse frequency will be reduced to nominal immediately in the event of r0027 greater than r0067 (current limit).</li> </ul> <p>P0290 = 2, 3:</p> <ul style="list-style-type: none"> <li>The pulse frequency P1800 is reduced only if higher than 2 kHz and if the operating frequency is below 2 Hz.</li> <li>The actual pulse frequency is displayed in r1801[0] and the minimal pulse frequency for reduction is displayed in r1801[1].</li> <li>Inverter I<sup>2</sup>t acts upon output current and output frequency, but not on pulse frequency.</li> </ul> <p>A trip will always result, if the action taken does not sufficiently reduce internal temperatures.</p>							
P0291[0...2]	<b>Inverter protection</b>	0 - 7	1	T	-	DDS	U16	4
	Bit 00 for enabling/disabling automatic pulse frequency reduction at output frequencies below 2 Hz. The benefit is to reduce the noises at frequencies below 2 Hz.							
	<b>Bit</b>	<b>Signal name</b>			<b>1 signal</b>	<b>0 signal</b>		
	00	Pulse frequency reduced below 2 Hz			Yes	No		
	01	Reserved			Yes	No		
	02	Phase loss detection enable			Yes	No		
<b>Note:</b>	See P0290							

Parameter	Function	Range	Factory default	Can be changed	Scaling	Data set	Data type	Acc. Level
P0292	<b>Inverter temperature warning [°C]</b>	0 - 25	5	U, T	-	-	U16	3
	Defines the temperature difference (in °C) between the overtemperature trip threshold (F4) and the warning threshold (A504) of the inverter. The trip threshold is stored internally by the inverter and cannot be changed by the user.							
P0294	<b>Inverter I<sup>2</sup>t warning [%]</b>	10.0 - 100.0	95.0	U, T	-	-	Float	3
	Defines the [%] value at which warning A505 (inverter I <sup>2</sup> t) is generated. Inverter I <sup>2</sup> t calculation is used to determine a maximum tolerable period for inverter overload. The I <sup>2</sup> t calculation value is deemed = 100 % when this maximum tolerable period is reached.							
<b>Dependency:</b>	<ul style="list-style-type: none"> <li>The output current of the inverter has been reduced.</li> <li>The value of I<sup>2</sup>t does not exceed 100 %.</li> </ul>							
<b>Note:</b>	P0294 = 100 % corresponds to stationary nominal load.							
P0295	<b>Inverter fan off delay time [s]</b>	0 - 3600	0	U, T	-	-	U16	3
	Defines inverter fan switch off delay time in seconds after inverter has stopped.							
<b>Note:</b>	Setting to 0, inverter fan will switch off when the inverter stops, that means no delay.							
P0304[0...2]	<b>Rated motor voltage [V]</b>	10 - 2000	400	C(1)	-	DDS	U16	1
	Nominal motor voltage from rating plate.							
<b>Dependency:</b>	Changeable only when P0010 = 1 (quick commissioning). Default value is depending on inverter type and its rating data.							
<b>Caution:</b>	The input of rating plate data must correspond with the wiring of the motor (star / delta). This means, if delta wiring is used for the motor, delta rating plate data has to be entered.							
	<p>IEC Motor</p> <p style="text-align: center;">Delta connection                      Star connection</p>							

Parameter	Function	Range	Factory default	Can be changed	Scaling	Data set	Data type	Acc. Level
<b>Note:</b>	Following diagram shows a typical rating plate with the locations of the relevant motor data.							
P0305[0...2]	<b>Rated motor current [A]</b>	0.01 - 10000.00	1.86	C(1)	-	DDS	Float	1
	Nominal motor current from rating plate.							
<b>Dependency:</b>	Changeable only when P0010 = 1 (quick commissioning). Depends also on P0320 (motor magnetization current).							
<b>Note:</b>	The maximum value of P0305 depends on the maximum inverter current r0209 and the motor type: Asynchronous motor : P0305_max = P0209 It is recommended that the ratio of P0305 (rated motor current) and r0207 (rated inverter current) should not be lower than: $(1 / 8) \leq (P0305 / r0207)$ When the relation of the nominal motor current P0305 and half of the maximal inverter current (r0209) exceeds 1.5 an additional current derating is applied. This is necessary to protect the inverter from harmonic current waves.							
	Default value is depending on inverter type and its rating data.							
P0307[0...2]	<b>Rated motor power</b>	0.01 - 2000.00	0.75	C(1)	-	DDS	Float	1
	Nominal motor power [kW / hp] from rating plate.							
<b>Dependency:</b>	If P0100 = 1, values will be in [hp]. Changeable only when P0010 = 1 (quick commissioning).							
<b>Note:</b>	Default value is depending on inverter type and its rating data.							
P0308[0...2]	<b>Rated motor cosφ</b>	0.000 - 1.000	0.000	C(1)	-	DDS	Float	1
	Nominal motor power factor (cosφ) from rating plate.							
<b>Dependency:</b>	Changeable only when P0010 = 1 (quick commissioning). Visible only when P0100 = 0 or 2, (motor power entered in [kW]). Setting 0 causes internal calculation of value. The value is displayed in r0332.							

Parameter	Function	Range	Factory default	Can be changed	Scaling	Data set	Data type	Acc. Level
P0309[0...2]	<b>Rated motor efficiency [%]</b>	0.0 - 99.9	0.0	C(1)	-	DDS	Float	1
	Nominal motor efficiency from rating plate.							
<b>Dependency:</b>	Changeable only when P0010 = 1 (quick commissioning). Visible only when P0100 = 1, (i.e. motor power entered in [hp]). Setting 0 causes internal calculation of value. The value is displayed in r0332.							
P0310[0...2]	<b>Rated motor frequency [Hz]</b>	12.00 - 550.00	50.00	C(1)	-	DDS	Float	1
	Nominal motor frequency from rating plate.							
<b>Dependency:</b>	Changeable only when P0010 = 1 (quick commissioning). Pole pair number recalculated automatically if parameter is changed.							
<b>Note:</b>	Changes to P0310 can influence the maximum motor frequency. For further information see P1082.							
P0311[0...2]	<b>Rated motor speed [RPM]</b>	0 - 40000	1395	C(1)	-	DDS	U16	1
	Nominal motor speed from rating plate.							
<b>Dependency:</b>	Changeable only when P0010 = 1 (quick commissioning). Setting 0 causes internal calculation of value. Slip compensation in V/f control requires rated motor speed for correct operation. Pole pair number recalculated automatically if parameter is changed.							
<b>Note:</b>	Default value is depending on inverter type and its rating data.							
r0313[0...2]	<b>Motor pole pairs</b>	-	-	-	-	DDS	U16	3
	Displays number of motor pole pairs that the inverter is currently using for internal calculations.							
<b>Dependency:</b>	Recalculated automatically when P0310 (rated motor frequency) or P0311 (rated motor speed) is changed. r0313 = 1: 2-pole motor r0313 = 2: 4-pole motor ...							
P0314[0...2]	<b>Motor pole pair number</b>	0 - 99	0	C(1)	-	DDS	U16	3
	Specifies number of pole pairs of motor.							
<b>Dependency:</b>	Changeable only when P0010 = 1 (quick commissioning). Setting 0 causes r0313 (calculated motor pole pairs) to be used during operation. Setting to > 0 overrides r0313. P0314 = 1: 2-pole motor P0314 = 2: 4-pole motor ...							
P0320[0...2]	<b>Motor magnetizing current [%]</b>	0.0 - 99.0	0.0	C, T	-	DDS	Float	3
	Defines motor magnetization current relative to P0305 (rated motor current).							
<b>Dependency:</b>	Setting 0 causes calculation by P0340 = 1 (data entered from rating plate) or by P3900 = 1 - 3 (end of quick commissioning). The calculated value is displayed in r0331.							
r0330[0...2]	<b>Rated motor slip [%]</b>	-	-	-	PERCENT	DDS	Float	3
	Displays nominal motor slip relative to P0310 (rated motor frequency) and P0311 (rated motor speed). $r0330[\%] = ((P0310 - r0313 * (P0311 / 60)) / P0310) * 100\%$							

Parameter list

7.2 Parameter list

Parameter	Function	Range	Factory default	Can be changed	Scaling	Data set	Data type	Acc. Level
r0331[0...2]	<b>Rated magnetization current [A]</b>	-	-	-	-	DDS	Float	3
	Displays calculated magnetizing current of motor.							
r0332[0...2]	<b>Rated power factor</b>	-	-	-	-	DDS	Float	3
	Displays power factor for motor.							
<b>Dependency:</b>	Value is calculated internally if P0308 (rated motor $\cos\phi$ ) set to 0; otherwise, value entered in P0308 is displayed.							
r0333[0...2]	<b>Rated motor torque [Nm]</b>	-	-	-	-	DDS	Float	3
	Displays rated motor torque.							
<b>Dependency:</b>	Value is calculated from P0307 (rated motor power) and P0311 (rated motor speed). $r0333[\text{Nm}] = (P0307[\text{kW}] * 1000) / ((P0311[1 / \text{min}] / 60) * 2 * \text{Pi})$							
P0335[0...2]	<b>Motor cooling</b>	0 - 3	0	C, T	-	DDS	U16	2
	Selects motor cooling system used.							
	0	Self-cooled: Shaft mounted fan attached motor						
	1	Force-cooled: Separately powered cooling fan						
	2	Self-cooled and internal fan						
	3	Force-cooled and internal fan						
P0340[0...2]	<b>Calculation of motor parameters</b>	0 - 4	0	T	-	DDS	U16	2
	Calculates various motor parameters.							
				P0340 = 1	P0340 = 2	P0340 = 3	P0340 = 4	
	P0341[0...2] Motor inertia [kg*m^2]			x				
	P0342[0...2] Total / motor inertia ratio			x				
	P0344[0...2] Motor weight			x				
	P0346[0...2] Magnetization time			x		x		
	P0347[0...2] Demagnetization time			x		x		
	P0350[0...2] Stator resistance (line-to-line)			x	x			
	P0352[0...2] Cable resistance			x	x			
	P0354[0...2] Rotor resistance			x	x			
	P0356[0...2] Stator leakage inductance			x	x			
	P0358[0...2] Rotor leakage inductance			x	x			
	P0360[0...2] Main inductance			x	x			
	P0625[0...2] Surrounding motor temperature			x	x			
	P1253[0...2] Controller output limitation			x		x		
	P1316[0...2] Boost end frequency			x		x		
	P1338[0...2] Resonance damping gain V/f			x		x	x	
	P1341[0...2] I <sub>max</sub> controller integral time			x		x	x	
	P1345[0...2] I <sub>max</sub> voltage ctrl. prop. gain			x		x	x	
	P1346[0...2] I <sub>max</sub> voltage ctrl. integral time			x		x	x	
	P2002[0...2] Reference current			x				
	P2003[0...2] Reference torque			x				
	P2185[0...2] Upper torque threshold 1			x				

Parameter	Function	Range	Factory default	Can be changed	Scaling	Data set	Data type	Acc. Level
	P2187[0...2] Upper torque threshold 2			x				
	P2189[0...2] Upper torque threshold 3			x				
	0	No calculation						
	1	Complete parameterization						
	2	Calculation of equivalent circuit data						
	3	Calculation of V/f control data						
	4	Calculation of controller settings only						
<b>Note:</b>	<p>This parameter is required during commissioning to optimize inverter performance. If there is a large mismatch in Power ratings of Inverter to Motor it is possible that r0384 and r0386 may not be calculated correctly. In these cases use P1900.</p> <p>When transferring P0340, the inverter uses its processor to carry out internal calculations. Communications to the inverter may be interrupted.</p> <p>The faults can be acknowledged as soon as the calculations have been completed in the inverter. These calculations can take approximately 10s to complete.</p>							
P0341[0...2]	<b>Motor inertia [kg*m<sup>2</sup>]</b>	0.0001 - 1000.0	0.0018	U, T	-	DDS	Float	3
	<p>Sets no-load inertia of motor.</p> <p>Together with P0342 (inertia ratio total / motor) and P1496 (scaling factor acceleration), this value produces the acceleration torque (r1518), which can be added to any additional torque produced from a BICO source (P1511), and incorporated in the torque control function.</p>							
<b>Dependency:</b>	This parameter is influenced by automatic calculations defined by P0340.							
<b>Note:</b>	<p>The result of P0341 * P0342 is included in the speed controller calculation.</p> <p>P0341 * P0342 = total motor inertia</p> <p>P1496 = 100 % activates acceleration pre-control for the speed controller and calculates the torque from P0341 and P0342.</p>							
P0342[0...2]	<b>Total / motor inertia ratio</b>	1.000 - 400.00	1.000	U, T	-	DDS	Float	3
	Specifies ratio between total inertia (load + motor) and motor inertia.							
<b>Dependency:</b>	See P0341							
P0344[0...2]	<b>Motor weight [kg]</b>	1.0 - 6500.0	9.4	U, T	-	DDS	Float	3
	Specifies motor weight [kg].							
<b>Dependency:</b>	See P0341							
<b>Note:</b>	This value is used in the motor thermal model. It is normally calculated automatically from P0340 (motor parameters) but can also be entered manually. Default value is depending on inverter type and its rating data.							
r0345[0...2]	<b>Motor start-up time [s]</b>	-	-	-	-	DDS	Float	3
	Displays motor start-up time. This time corresponds to the standardized motor inertia. The start-up time is the time taken to reach rated motor speed from standstill at acceleration with rated motor torque (r0333).							
P0346[0...2]	<b>Magnetization time [s]</b>	0.000 - 20.000	1.000	U, T	-	DDS	Float	3
	Sets magnetization time [s], i.e. waiting time between pulse enable and start of ramp-up. Motor magnetization builds up during this time. Magnetization time is normally calculated automatically from the motor data and corresponds to the rotor time constant.							
<b>Dependency:</b>	See P0341							

Parameter	Function	Range	Factory default	Can be changed	Scaling	Data set	Data type	Acc. Level
<b>Notice:</b>	An excessive reduction of this time can result in insufficient motor magnetization.							
<b>Note:</b>	If boost settings are higher than 100 %, magnetization time may be reduced. Default value is depending on inverter type and its rating data.							
P0347[0...2]	<b>Demagnetization time [s]</b>	0.000 - 20.000	1.000	U, T	-	DDS	Float	3
	Changes time allowed after OFF2 / fault condition, before pulses can be re-enabled.							
<b>Dependency:</b>	See P0341							
<b>Notice:</b>	Not active following a normally completed ramp-down, e.g. after OFF1, OFF3 or JOG. Overcurrent trips will occur if the time is decreased excessively.							
<b>Note:</b>	The demagnetization time is approximately 2.5 x rotor time constant in seconds. Default value is depending on inverter type and its rating data.							
P0350[0...2]	<b>Stator resistance (line) [Ω]</b>	0.00001 - 2000.0	2.0000	U, T	-	DDS	Float	3
	Stator resistance value for connected motor (line value). The parameter value doesn't include the cable resistance.							
<b>Dependency:</b>	See P0341							
<b>Note:</b>	<p>There are three ways to determine the value for this parameter:</p> <ul style="list-style-type: none"> <li>• Calculate using <ul style="list-style-type: none"> <li>– P0340 = 1 (data entered from rating plate) or</li> <li>– P0010 = 1, P3900 = 1, 2 or 3 (end of quick commissioning).</li> </ul> </li> <li>• Measure using P1900 = 2 (standard motor data identification - value for stator resistance is overwritten).</li> <li>• Measure manually using an Ohmmeter.</li> </ul> <p>Since the manually measured resistor is a line-to-line value, which includes the cable resistors, the measured value has to be divided by two and the cable resistor of a line has to be subtracted from that value. The value entered in P0350 is the one obtained by the method last used. Default value is depending on inverter type and its rating data.</p>							
P0352[0...2]	<b>Cable resistance [Ω]</b>	0.0 - 120.0	0.0	U, T	-	DDS	Float	3
	Describes cable resistance between inverter and motor for one phase. The value corresponds to the resistance of the cable between the inverter and the motor, relative to the rated impedance.							
<b>Dependency:</b>	See P0341							
P0354[0...2]	<b>Rotor resistance [Ω]</b>	0.0 - 300.0	10.0	U, T	-	DDS	Float	3
	Sets rotor resistance of motor equivalent circuit (phase value).							
<b>Dependency:</b>	Calculated automatically using the motor model or determined using P1900 (motor identification). This parameter is influenced by automatic calculations defined by P0340.							
P0356[0...2]	<b>Stator leakage inductance [mH]</b>	0.00001 - 1000.0	10.000	U, T	-	DDS	Float	3
	Sets stator leakage inductance of motor equivalent circuit (phase value).							
<b>Dependency:</b>	See P0354							
P0358[0...2]	<b>Rotor leakage inductance [mH]</b>	0.0 - 1000.0	10.0	U, T	-	DDS	Float	3
	Sets rotor leakage inductance of motor equivalent circuit (phase value).							
<b>Dependency:</b>	See P0354							



Parameter	Function	Range	Factory default	Can be changed	Scaling	Data set	Data type	Acc. Level
P0360[0...2]	<b>Main inductance [mH]</b>	0.0 - 10000.0	10.0	U, T	-	DDS	Float	3
	Sets main inductance of the motor equivalent circuit (phase value).							
<b>Dependency:</b>	See P0354							
<b>Caution:</b>	The data of equivalent circuit relates to the star equivalent circuit. Any data of the delta equivalent circuit available therefore must be transformed to the star equivalent circuit before entering into the inverter.							
r0370[0...2]	<b>Stator resistance [%]</b>	-	-	-	PERCENT	DDS	Float	4
	Displays standardized stator resistance of motor equivalent circuit (phase value).							
r0372[0...2]	<b>Cable resistance [%]</b>	-	-	-	PERCENT	DDS	Float	4
	Displays standardized cable resistance of motor equivalent circuit (phase value). It is estimated to be 20 % of the stator resistance.							
r0373[0...2]	<b>Rated stator resistance [%]</b>	-	-	-	PERCENT	DDS	Float	4
	Displays rated stator resistance of the motor equivalent circuit (phase value).							
r0374[0...2]	<b>Rotor resistance [%]</b>	-	-	-	PERCENT	DDS	Float	4
	Displays standardized rotor resistance of the motor equivalent circuit (phase value).							
r0376[0...2]	<b>Rated rotor resistance [%]</b>	-	-	-	PERCENT	DDS	Float	4
	Displays rated rotor resistance of the motor equivalent circuit (phase value).							
r0377[0...2]	<b>Total leakage reactance [%]</b>	-	-	-	PERCENT	DDS	Float	4
	Displays standardized total leakage reactance of the motor equivalent circuit (phase value).							
r0382[0...2]	<b>Main reactance [%]</b>	-	-	-	PERCENT	DDS	Float	4
	Displays standardized main reactance of the motor equivalent circuit (phase value).							
r0384[0...2]	<b>Rotor time constant [ms]</b>	-	-	-	-	DDS	Float	3
	Displays calculated rotor time constant.							
r0386[0...2]	<b>Total leakage time constant [ms]</b>	-	-	-	-	DDS	Float	4
	Displays total leakage time constant of motor.							
r0395	<b>CO: Total stator resistance [%]</b>	-	-	-	PERCENT	-	Float	3
	Displays stator resistance of motor of combined stator / cable resistance.							
P0503[0...2]	<b>Enable Keep-running Operation</b>	0 - 1	0	T	-	-	U16	3
	Enables keep-running operation. This attempts to prevent the inverter from tripping by enabling all possible existing de-rating features, and the automatic restart function. May be used with P2113 = 1 (inverter warnings disabled) to mask resulting warnings from the user.							
	0	Keep-running mode disabled						
	1	Keep-running mode enabled						
<b>Index:</b>	[0]	Inverter data set 0 (DDS0)						
	[1]	Inverter data set 1 (DDS1)						
	[2]	Inverter data set 2 (DDS2)						

7.2 Parameter list

Parameter	Function	Range	Factory default	Can be changed	Scaling	Data set	Data type	Acc. Level
<b>Note:</b>	P0503 = 1 Sets the following parameter values to minimize likelihood of a trip: <ul style="list-style-type: none"> <li>• P0290 = 2 (inverter overload reaction: reduce pulse frequency, output current and output frequency)</li> <li>• P1210 = 7 (automatic restart function: restart after mains brown- /blackout or fault, trip when P1211 expires)</li> <li>• P1211 = 10 (number of times inverter will attempt to restart)</li> <li>• P1240 = 3 (configuration of Vdc controller: Vdc_max controller and kinetic buffering (KIB) enabled)</li> </ul> P0503 = 0 Resets the parameters to their default values: <ul style="list-style-type: none"> <li>• P0290 = 2 (inverter overload reaction: reduce pulse frequency, output current and output frequency)</li> <li>• P1210 = 1 (automatic restart function: trip reset after power on, P1211 disabled)</li> <li>• P1211 = 3 (number of times inverter will attempt to restart)</li> <li>• P1240 = 1(configuration of Vdc controller: Vdc_max controller enabled)</li> </ul>							
<b>Note:</b>	See also P0290, P1210, P1211, P1240, and P2113							
P0507	<b>Application macro</b>	0 - 255	0	C(1)	-	-	U16	1
	Selects a given Application macro, which is a set of parameter values for a given application. There are a number of application macros covering a set of basic applications such as simple pump, conveyor, compressor etc.							
<b>Note:</b>	Please note that to guarantee correct setting of the Application macro, the Application macro number should only be changed during Setup directly after a parameter reset.							
P0511[0...2]	<b>Scaling for display</b>	0.00 - 100.00	[0] 1.00 [1] 1.00 [2] 0.00	U, T	-	-	Float	3
	Allows operator to enter the scaling factors for the display of motor frequency. Index 0 = value of multiplier (a) Index 1 = value of divisor (b) Index 2 = value of constant (c) With the parameter set to a non-default value the displayed value for frequency and setpoint on internal and external BOPs is scaled accordingly. Note - the units "Hz" is no longer displayed if the value is scaled. The formula used to scale the display is: (a / b)*N + c.							
<b>Index:</b>	[0]	Multiplier for Scaling for display						
	[1]	Divider for Scaling for display						
	[2]	Constant for Scaling for display						
r0512	<b>CO: Scaled filtered frequency</b>	-	-	-	-	-	Float	2
	Displays actual inverter output frequency (r0024) excluding slip compensation (and resonance damping, frequency limitation in V/f mode).							
P0604[0...2]	<b>Threshold motor temperature [°C]</b>	0.0 - 200.0	130.0	U, T	-	DDS	Float	2
	Enters warning threshold for motor temperature protection. The trip temperature defined is always 10 % higher than the warning threshold P0604. When actual motor temperature exceeds warning temperature then inverter reacts as defined in P0610.							
<b>Dependency:</b>	This value should be at least 40°C higher than the motor surrounding temperature P0625.							

Parameter	Function	Range	Factory default	Can be changed	Scaling	Data set	Data type	Acc. Level
P0610[0...2]	<b>Motor I<sup>2</sup>t temperature reaction</b>	0 - 6	6	T	-	DDS	U16	3
	Defines reaction when motor temperature reaches warning threshold.							
	0	Warning only. Does not recall the motor temperature (stored at power down) on power up						
	1	Warning with I <sub>max</sub> control (motor current reduced) and trip (F11). Does not recall the motor temperature (stored at power down) on power up						
	2	Warning and trip (F11). Does not recall the motor temperature (stored at power down) on power up						
	4	Warning only. Recalls the motor temperature (stored at power down) on power up						
	5	Warning with I <sub>max</sub> control (motor current reduced) and trip (F11). Recalls the motor temperature (stored at power down) on power up						
	6	Warning and trip (F11). Recalls the motor temperature (stored at power down) on power up						
<b>Dependency:</b>	Trip level = P0604 (motor temperature threshold) * 110 %							
<b>Note:</b>	<ul style="list-style-type: none"> <li>• P0610 = 0 (No reaction, warning only) When temperature reaches warning level defined in P0604, the inverter displays warning A511, no reaction is done.</li> <li>• P0610 = 1 (Warning, I<sub>max</sub> reduction and Trip) When temperature reaches warning level defined in P0604, the inverter displays warning A511, reduce frequency and trips F11, when temperature exceeds the trip level.</li> <li>• P0610 = 2 (Warning and trip F11) When temperature reaches warning level defined in P0604, the inverter displays warning A511 and trips F11, when temperature exceeds the trip level.</li> </ul> <p>The purpose of motor I<sup>2</sup>t is to calculate the motor temperature and disable the inverter if the motor is in danger of overheating.</p> <p>I<sup>2</sup>t operation: The measured motor current is displayed in r0027. The motor temperature in °C is displayed in r0035. This temperature is derived from a calculated value using motor thermal model. The reaction to the warning can be changed from this default using P0610. r0035 is particularly useful to monitor if the calculated motor temperature is rising excessively.</p>							
P0622[0...2]	<b>Magnetizing time for temp id after start up [ms]</b>	0.000 - 20000	0.000	U, T	-	DDS	Float	3
	Specifies the magnetization time for stator resistance identification.							
r0623[0...2]	<b>CO: Display for the identified stator resistance [Ω]</b>	-	-	-	-	DDS	Float	4
	Display of the actual identified stator resistance after temperature identification.							
P0625[0...2]	<b>Surrounding motor temperature [°C]</b>	-40.0 - 80.0	20.0	C, U, T	-	DDS	Float	3
	Surrounding temperature of motor at time of motor data identification. It is only allowed to change the value when the motor is cold. A motor identification has to be made after changing the value.							
<b>Dependency:</b>	This parameter is influenced by automatic calculations defined by P0340.							

7.2 Parameter list

Parameter	Function	Range	Factory default	Can be changed	Scaling	Data set	Data type	Acc. Level
P0626[0...2]	<b>Overtemperature stator iron [°C]</b>	20.0 - 200.0	50.0	U, T	-	DDS	Float	4
	Overtemperature of stator iron.							
<b>Note:</b>	Temperature rises are valid for sinusoidal operations (line supply temperature rises). Temperature rises due to inverter operation (modulation losses) and output filter are also considered.							
P0627[0...2]	<b>Overtemperature stator winding [°C]</b>	20.0 - 200.0	80.0	U, T	-	DDS	Float	4
	Overtemperature of the stator winding. It is only allowed to change the value when the motor is cold. A motor identification has to be made after changing the value.							
<b>Note:</b>	See P0626							
P0628[0...2]	<b>Overtemperature rotor winding [°C]</b>	20.0 - 200.0	100.0	U, T	-	DDS	Float	4
	Overtemperature of the rotor winding.							
<b>Note:</b>	See P0626							
r0630[0...2]	<b>CO: Motor model surrounding temp. [°C]</b>	-	-	-	-	DDS	Float	4
	Displays surrounding temperature of motor mass model.							
r0631[0...2]	<b>CO: Stator iron temperature [°C]</b>	-	-	-	-	DDS	Float	4
	Displays iron temperature of motor mass model.							
r0632[0...2]	<b>CO: Stator winding temperature [°C]</b>	-	-	-	-	DDS	Float	4
	Displays stator winding temperature of motor mass model.							
r0633[0...2]	<b>CO: Rotor winding temperature [°C]</b>	-	-	-	-	DDS	Float	4
	Displays rotor winding temperature of motor mass model.							
P0640[0...2]	<b>Motor overload factor [%]</b>	10.0 - 400.0	150.0	C, U, T	-	DDS	Float	2
	Defines motor overload current limit relative to P0305 (rated motor current).							
<b>Dependency:</b>	Limited to maximum inverter current or to 400 % of rated motor current (P0305), whichever is the lower. $P0640\_max = (\min(r0209, 4 * P0305) / P0305) * 100$							
<b>Note:</b>	Changes to P0640 will be effective only after the next off state.							
P0700[0...2]	<b>Selection of command source</b>	0 - 5	1	C, T	-	CDS	U16	1
	Selects digital command source.							
	0	Factory default setting						
	1	Operator panel (keypad)						
	2	Terminal						
	5	USS / MBUS on RS485						
<b>Dependency:</b>	Changing this parameter sets (to default) all settings on item selected. These are the following parameters: P0701, ... (function of digital input), P0840, P0842, P0844, P0845, P0848, P0849, P0852, P1020, P1021, P1022, P1023, P1035, P1036, P1055, P1056, P1074, P1110, P1113, P1124, P1140, P1141, P1142, P1230, P2103, P2104, P2106, P2200, P2220, P2221, P2222, P2223, P2235, P2236							
<b>Caution:</b>	Be aware, by changing of P0700 all BI parameters are reset to the default value.							

Parameter	Function	Range	Factory default	Can be changed	Scaling	Data set	Data type	Acc. Level
<b>Note:</b>	RS485 also supports MODBUS protocol as well as USS. All USS options on RS485 are also applicable to MODBUS.							
P0701[0...2]	<b>Function of digital input 1</b>	0 - 99	0	T	-	CDS	U16	2
	Selects function of digital input 1.							
	0	Digital input disabled						
	1	ON / OFF1						
	2	ON reverse / OFF1						
	3	OFF2 - coast to standstill						
	4	OFF3 - quick ramp-down						
	5	ON / OFF2						
	9	Fault acknowledge						
	10	JOG right						
	11	JOG left						
	12	Reverse						
	13	MOP up (increase frequency)						
	14	MOP down (decrease frequency)						
	15	Fixed frequency selector bit0						
	16	Fixed frequency selector bit1						
	17	Fixed frequency selector bit2						
	18	Fixed frequency selector bit3						
	22	QuickStop Source 1						
	23	QuickStop Source 2						
	24	QuickStop Override						
	25	DC brake enable						
	27	Enable PID						
	29	External trip						
	33	Disable additional freq setpoint						
	99	Enable BICO parameterization						
<b>Dependency:</b>	Resetting 99 (enable BICO parameterization) requires: <ul style="list-style-type: none"> <li>• P0700 command source or</li> <li>• P0010 = 1, P3900 = 1, 2 or 3 (quick commissioning) or</li> <li>• P0010 = 30, P0970 = 1 factory reset in order to reset</li> </ul>							
<b>Note:</b>	"ON / OFF1" can only be selected for one digital input (e.g. P0700 = 2 and P0701 = 1). Configuring DI2 with P0702 = 1 will disable digital input 1 by setting P0701 = 0. Only the last activated digital input serves as a command source. "ON / OFF1" on a digital input can be combined with "ON reverse / OFF1" on another digital input.							
P0702[0...2]	<b>Function of digital input 2</b>	0 - 99	0	T	-	CDS	U16	2
	Selects function of digital input 2. See P0701.							
P0703[0...2]	<b>Function of digital input 3</b>	0 - 99	9	T	-	CDS	U16	2
	Selects function of digital input 3. See P0701.							

Parameter list

7.2 Parameter list

Parameter	Function	Range	Factory default	Can be changed	Scaling	Data set	Data type	Acc. Level
P0704[0...2]	<b>Function of digital input 4</b>	0 - 99	15	T	-	CDS	U16	2
	Selects function of digital input 4. See P0701.							
P0712[0...2]	<b>Analog / digital input 1</b>	0 - 99	0	T	-	CDS	U16	2
	Selects function of digital input AI1 (via analog input). See P0701.							
<b>Note:</b>	See P0701. Signals above 4 V are active; signals below 1.6 V are inactive.							
P0713[0...2]	<b>Analog / digital input 2</b>	0 - 99	0	T	-	CDS	U16	2
	Selects function of digital input AI2 (via analog input). See P0701.							
<b>Note:</b>	See P0701. Signals above 4 V are active; signals below 1.6 V are inactive.							
P0717	<b>Connection macro</b>	0 - 255	0	C(1)	-	-	U16	1
	Selects a given connection macro, which is a set of parameter values for a given set of control connections. There are a number of connection macros which define basic control connection settings such as Terminals, BOP, PID with analog setpoint etc.							
<b>Note:</b>	Please note that to guarantee correct setting of the Connection macro, the Connection macro number should only be changed during Setup directly after a parameter reset.							
P0719[0...2]	<b>Selection of command &amp; frequency setpoint</b>	0 - 57	0	T	-	CDS	U16	4
	Central switch to select control command source for inverter. Switches command and setpoint source between freely programmable BICO parameters and fixed command / setpoint profiles. Command and setpoint sources can be changed independently. The tens digit chooses the command source and the units digit chooses the setpoint source.							
	0	Cmd = BICO parameter, Setpoint = BICO parameter						
	1	Cmd = BICO parameter, Setpoint = MOP setpoint						
	2	Cmd = BICO parameter, Setpoint = Analog setpoint						
	3	Cmd = BICO parameter, Setpoint = Fixed frequency						
	4	Cmd = BICO parameter, Setpoint = USS on RS232 (reserved)						
	5	Cmd = BICO parameter, Setpoint = USS/MODBUS on RS485						
	7	Cmd = BICO parameter, Setpoint = Analog setpoint 2						
	40	Cmd = USS on RS232 (reserved), Setpoint = BICO parameter						
	41	Cmd = USS on RS232 (reserved), Setpoint = MOP setpoint						
	42	Cmd = USS on RS232 (reserved), Setpoint = Analog setpoint						
	43	Cmd = USS on RS232 (reserved), Setpoint = Fixed frequency						
	44	Cmd = USS on RS232 (reserved), Setpoint = USS on RS232 (reserved)						
	45	Cmd = USS on RS232 (reserved), Setpoint = USS/MODBUS on RS485						
	47	Cmd = USS on RS232 (reserved), Setpoint = Analog setpoint 2						
	50	Cmd = USS/MODBUS on RS485, Setpoint = BICO parameter						
	51	Cmd = USS/MODBUS on RS485, Setpoint = MOP setpoint						
	52	Cmd = USS/MODBUS on RS485, Setpoint = Analog setpoint						
	53	Cmd = USS/MODBUS on RS485, Setpoint = Fixed frequency						
	54	Cmd = USS/MODBUS on RS485, Setpoint = USS on RS232 (reserved)						
	55	Cmd = USS/MODBUS on RS485, Setpoint = USS/MODBUS on RS485						

Parameter	Function	Range	Factory default	Can be changed	Scaling	Data set	Data type	Acc. Level
	57	Cmd = USS/MODBUS on RS485, Setpoint = Analog setpoint 2						
<b>Dependency:</b>	P0719 has higher priority than P0700 and P1000. If set to a value other than 0 (i.e. BICO parameter is not the setpoint source), P0844 / P0848 (first source of OFF2 / OFF3) are not effective; instead, P0845 / P0849 (second source of OFF2 / OFF3) apply and the OFF commands are obtained via the particular source defined. BICO connections made previously remain unchanged.							
<b>Notice:</b>	Particularly useful when e.g. changing command source temporarily from P0700 = 2. Settings in P0719 (contrary to P0700 settings) do not reset the digital inputs (P0701, P0702, ...)							
r0720	<b>Number of digital inputs</b>	-	-	-	-	-	U16	3
	Displays number of digital inputs.							
r0722.0...12	<b>CO / BO: Digital input values</b>	-	-	-	-	-	U16	2
	Displays status of digital inputs.							
	<b>Bit</b>	<b>Signal name</b>			<b>1 signal</b>		<b>0 signal</b>	
	00	Digital input 1			Yes		No	
	01	Digital input 2			Yes		No	
	02	Digital input 3			Yes		No	
	03	Digital input 4			Yes		No	
	11	Analog input 1			Yes		No	
	12	Analog input 2			Yes		No	
<b>Note:</b>	Segment is lit when signal is active.							
P0724	<b>Debounce time for digital inputs</b>	0 - 3	3	T	-	-	U16	3
	Defines debounce time (filtering time) used for digital inputs.							
	0	No debounce time						
	1	2.5 ms debounce time						
	2	8.2 ms debounce time						
	3	12.3 ms debounce time						
P0727[0...2]	<b>Selection of 2 / 3-wire method</b>	0 - 3	0	C, T	-	CDS	U16	2

Parameter	Function	Range	Factory default	Can be changed	Scaling	Data set	Data type	Acc. Level
	<p>Determines the control method using the terminals. This parameter allows the selection of the control philosophy. The control philosophies exclude each other.</p> <p>2 / 3-wire control allows to start, stop and reverse the inverter in one of the following ways:</p> <ul style="list-style-type: none"> <li>2-wire control with Siemens standard control using ON / OFF1 and REV as permanent signals</li> </ul>							
	<ul style="list-style-type: none"> <li>2-wire control with Siemens standard control using ON / OFF1 and ON_REV / OFF1 as permanent signals</li> </ul>							
	<ul style="list-style-type: none"> <li>2-wire control using ON_FWD and ON_REV as permanent signals</li> </ul>							

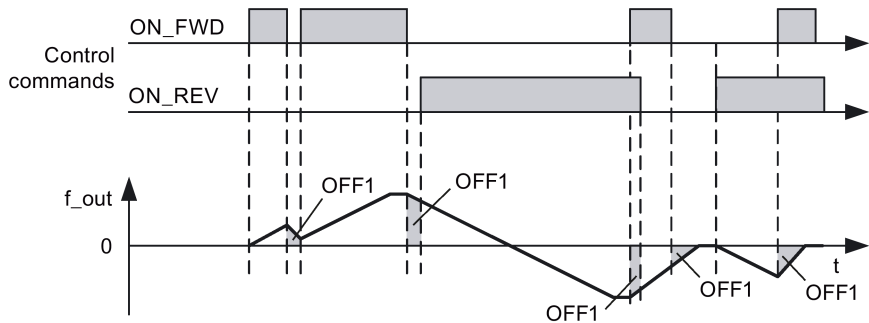
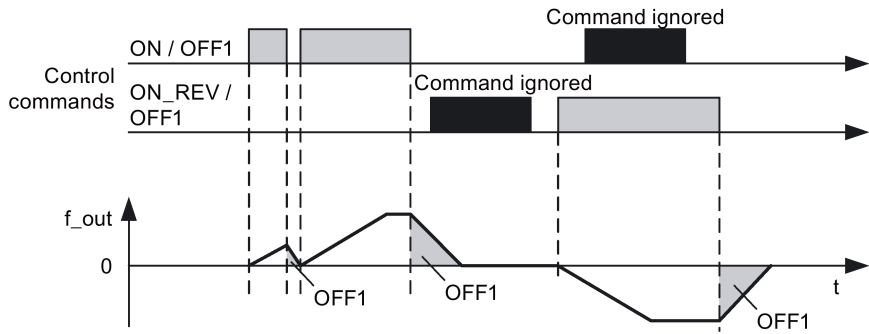
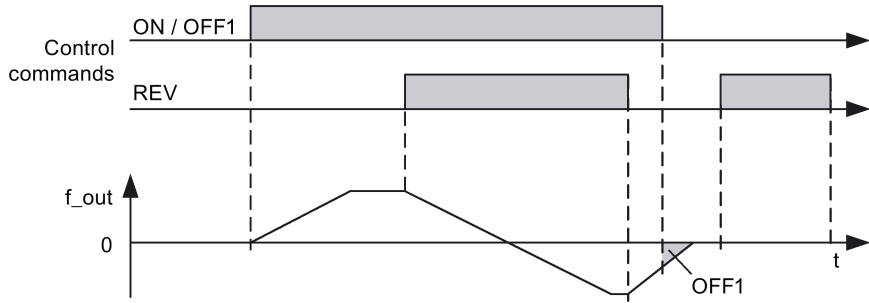



Parameter	Function	Range	Factory default	Can be changed	Scaling	Data set	Data type	Acc. Level
	<ul style="list-style-type: none"> <li>3-wire control</li> </ul> using STOP as permanent signal, FWD and REVP as pulses 							
	<ul style="list-style-type: none"> <li>3 wire control</li> </ul> using OFF1 / HOLD and REV as permanent signal, ON as pulse signal 							
	0	Siemens (start / dir)						
	1	2-wire (fwd / rev)						
	2	3-wire (fwd / rev)						
	3	3-wire (start / dir)						
<b>Note:</b>	Where: <ul style="list-style-type: none"> <li>P denotes Pulse</li> <li>FWD denotes FORWARD</li> <li>REV denotes REVERSE</li> </ul> When any of the control functions are selected using P0727, the setting for the digital inputs (P0701 - P0704) are redefined as follows:							
	Settings of P0701 - P0704	P0727 = 0 (Siemens Standard Control)	P0727 = 1 (2-wire Control)	P0727 = 2 (3-wire Control)	P0727 = 3 (3-wire Control)			
	= 1 (P0840)	ON / OFF1	ON_FWD	STOP	ON_PULSE			
	= 2 (P0842)	ON_REV / OFF1	ON_REV	FWDP	OFF1 / HOLD			
	= 12 (P1113)	REV	REV	REVP	REV			

Parameter list

7.2 Parameter list

Parameter	Function	Range	Factory default	Can be changed	Scaling	Data set	Data type	Acc. Level
	To use the 2 / 3-wire control, the sources for ON / OFF1 (P0840), ON_REV / OFF1 (P0842) and REV (P1113) corresponding to the redefined values have to be set accordingly. ON/OFF2 functionality is not supported in 2/3 wire modes. Do not select ON/OFF2 unless P0727 = 0.							
	Regarding the use of fixed frequencies see P1000 and P1001.							
r0730	<b>Number of digital outputs</b>	-	-	-	-	-	U16	3
	Displays number of digital outputs.							
P0731[0...2]	<b>BI: Function of digital output 1</b>	0 - 4294967295	52.3	U, T	-	CDS	U32 / Bin	2
	Defines source of digital output 1.							
<b>Notice:</b>	An inverse logic can be realized by inverting the digital outputs in P0748.							
<b>Note:</b>	Output of fault bit 52.3 is inverted on digital output. Therefore, with P0748 = 0, the digital output is set to low when a fault is triggered, and when there is no fault, it is set to high. Monitor functions ==> see r0052, r0053 Motor holding brake ==> see P1215 DC-Brake ==> see P1232, P1233							
P0732[0...2]	<b>BI: Function of digital output 2</b>	0 - 4294967295	52.7	U, T	-	CDS	U32 / Bin	2
	Defines source of digital output 2.							
r0747.0...1	<b>CO / BO: State of digital outputs</b>	-	-	-	-	-	U16	3
	Displays status of digital outputs (also includes inversion of digital outputs via P0748).							
	<b>Bit</b>	<b>Signal name</b>			<b>1 signal</b>	<b>0 signal</b>		
	00	Digital output 1 energized			Yes	No		
	01	Digital output 2 energized			Yes	No		
<b>Dependency:</b>	Bit = 0 signal: Contacts open Bit = 1 signal: Contacts closed							
P0748	<b>Invert digital outputs</b>	-	0000 bin	U, T	-	-	U16	3
	Defines high and low states of digital output for a given function.							
	<b>Bit</b>	<b>Signal name</b>			<b>1 signal</b>	<b>0 signal</b>		
	00	Invert digital output 1			Yes	No		
	01	Invert digital output 2			Yes	No		
r0750	<b>Number of analog inputs</b>	-	-	-	-	-	U16	3
	Displays number of analog inputs available.							
r0751.0...9	<b>CO / BO: Status word of analog input</b>	-	-	-	-	-	U16	3
	Displays status of analog input.							
	<b>Bit</b>	<b>Signal name</b>			<b>1 signal</b>	<b>0 signal</b>		
	00	Signal lost on analog input 1			Yes	No		
	01	Signal lost on analog input 2			Yes	No		
	08	No signal lost on analog input 1			Yes	No		
	09	No signal lost on analog input 2			Yes	No		
r0752[0...1]	<b>Actual analog input [V] or [mA]</b>	-	-	-	-	-	Float	2
	Displays smoothed analog input value in volts or million amps before the scaling block.							

Parameter	Function	Range	Factory default	Can be changed	Scaling	Data set	Data type	Acc. Level
<b>Index:</b>	[0]	Analog input 1 (AI1)						
	[1]	Analog input 2 (AI2)						
P0753[0...1]	<b>Smooth time analog input [ms]</b>	0 - 10000	3	U, T	-	-	U16	3
	Defines filter time (PT1 filter) for analog input.							
<b>Index:</b>	See r0752							
<b>Note:</b>	Increasing this time (smooth) reduces jitter but slows down response to the analog input. P0753 = 0: No filtering							
r0754[0...1]	<b>Actual analog input value after scaling [%]</b>	-	-	-	-	-	Float	2
	Shows smoothed value of analog input after scaling block.							
<b>Index:</b>	See r0752							
<b>Dependency:</b>	P0757 to P0760 define range (analog input scaling).							
r0755[0...1]	<b>CO: Actual analog input after scaling [4000h]</b>	-	-	-	4000H	-	I16	2
	<p>Displays analog input, scaled using ASPmin and ASPmax (ASP = analog setpoint). Analog setpoint (ASP) from the analog scaling block can vary from minimum analog setpoint (ASPmin) to a maximum analog setpoint (ASPmax). The largest magnitude (value without sign) of ASPmin and ASPmax defines the scaling of 16384. By associating r0755 with an internal value (e.g. frequency setpoint), a scaled value is calculated internally by the inverter.</p> <p>The frequency value is calculated using the following equation:  <math>r0755 \text{ [Hz]} = (r0755 \text{ [hex]} / 4000 \text{ [hex]}) * P2000 * (\max( ASP_{\max} ,  ASP_{\min} ) / 100\%)</math></p>							
<b>Example:</b>	<p>Case a:  ASPmin = 300 %, ASPmax = 100 % then 16384 represents 300 %.  This parameter will vary from 5461 to 16384.</p> <p>Case b:  ASPmin = -200 %, ASPmax = 100 % then 16384 represents 200 %.  This parameter will vary from -16384 to +8192.</p> <p style="text-align: center;"><math>4000 \text{ h} = \max( ASP_{\max} ,  ASP_{\min} )</math></p> <div style="display: flex; justify-content: space-around;"> <div style="text-align: center;"> <p>Graph (a) shows a downward-sloping line from 300% (ASP<sub>max</sub>) to 100% (ASP<sub>min</sub>) on the y-axis against 10V and 20mA on the x-axis. A dashed box indicates 4000 h ≈ 16384 dez.</p> </div> <div style="text-align: center;"> <p>Graph (b) shows an upward-sloping line from 200% (ASP<sub>min</sub>) to 100% (ASP<sub>max</sub>) on the y-axis against 10V and 20mA on the x-axis. A dashed box indicates 7FFF h ≈ -16383 dez.</p> </div> </div>							
<b>Index:</b>	See r0752							
<b>Note:</b>	This value is used as an input to analog BICO connectors. ASPmax represents the highest analog setpoint (this may be at 10 V). ASPmin represents the lowest analog setpoint (this may be at 0 V). See P0757 to P0760 (analog input scaling).							
P0756[0...1]	<b>Type of analog input</b>	0 - 4	0	T	-	-	U16	2
	Defines type of analog input and also enables analog input monitoring.							

7.2 Parameter list

Parameter	Function	Range	Factory default	Can be changed	Scaling	Data set	Data type	Acc. Level
	0	Unipolar voltage input (0 to 10 V)						
	1	Unipolar voltage input with monitoring (0 to 10 V)						
	2	Unipolar current input (0 to 20 mA)						
	3	Unipolar current input with monitoring (0 to 20 mA)						
	4	Bipolar voltage input (-10 V to 10 V)						
<b>Index:</b>	See r0752							
<b>Dependency:</b>	Function disabled if analog scaling block programmed to output negative setpoints (see P0757 to P0760).							
<b>Notice:</b>	When monitoring is enabled and a deadband defined (P0761), a fault condition will be generated (F80) if the analog input voltage falls below 50 % of the deadband voltage. It is not possible to select the bipolar voltage for analog input 2.							
<b>Note:</b>	See P0757 to P0760 (analog input scaling). In current mode, if the input exceeds 24mA, the inverter will trip F80/11 for analog input 1 and F80/12 for analog input 2. This will result in channel switching back to voltage mode. Analog input parameter readings for the channel concerned will no longer be updated until the fault (F80) has been reset. Once the fault has been reset then the input will switch back to current mode and normal readings will resume.							
P0757[0...1]	<b>Value x1 of analog input scaling</b>	-20 - 20	0	U, T	-	-	Float	2
	P0757 - P0760 configure the input scaling. x1 is the first value of the two pairs of variants x1 / y1 and x2 / y2 which determine the straight line. The value x2 of analog input scaling P0759 must be greater than the value x1 of analog input scaling P0757.							
<b>Index:</b>	See r0752							
<b>Notice:</b>	<ul style="list-style-type: none"> <li>Analog setpoints represent a [%] of the normalized frequency in P2000.</li> <li>Analog setpoints may be larger than 100 %.</li> <li>ASPmax represents highest analog setpoint (this may be at 10 V or 20 mA).</li> <li>ASPmin represents lowest analog setpoint (this may be at 0 V or 20 mA).</li> <li>Default values provide a scaling of 0 V or 0 mA = 0 %, and 10 V or 20 mA = 100 %.</li> </ul>							
P0758[0...1]	<b>Value y1 of analog input scaling [%]</b>	-99999.9 - 99999.9	0.0	U, T	-	-	Float	2
	Sets value of y1 as described in P0757 (analog input scaling)							
<b>Index:</b>	See r0752							
<b>Dependency:</b>	Affects P2000 to P2003 (reference frequency, voltage, current or torque) depending on which setpoint is to be generated.							
P0759[0...1]	<b>Value x2 of analog input scaling</b>	-20 - 20	10	U, T	-	-	Float	2
	Sets value of x2 as described in P0757 (analog input scaling).							
<b>Index:</b>	See r0752							
<b>Notice:</b>	The value x2 of analog input scaling P0759 must be greater than the value x1 of analog input scaling P0757.							
P0760[0...1]	<b>Value y2 of analog input scaling [%]</b>	-99999.9 - 99999.9	100.0	U, T	-	-	Float	2
	Sets value of y2 as described in P0757 (analog input scaling).							
<b>Index:</b>	See r0752							
<b>Dependency:</b>	See P0758							
P0761[0...1]	<b>Width of analog input deadband</b>	0 - 20	0	U, T	-	-	Float	2
	Defines width of deadband on analog input.							

Parameter	Function	Range	Factory default	Can be changed	Scaling	Data set	Data type	Acc. Level
<b>Example:</b>	<p>The below example produces a 2 to 10 V, 0 to 50 Hz analog input (analog input value 2 to 10 V, 0 to 50 Hz):</p> <ul style="list-style-type: none"> <li>• P2000 = 50 Hz</li> <li>• P0759 = 8 V P0760 = 75 %</li> <li>• P0757 = 2 V P0758 = 0 %</li> <li>• P0761 = 2 V</li> <li>• P0756 = 0 or 1</li> </ul> <p>The below example produces a 0 to 10 V analog input (-50 to +50 Hz) with center zero and a "holding point" 0.2 V wide (0.1 V to each side of center, analog input value 0 to 10 V, -50 to +50 Hz):</p> <ul style="list-style-type: none"> <li>• P2000 = 50 Hz</li> <li>• P0759 = 8.75 V P0760 = 75 %</li> <li>• P0757 = 1.25 V P0758 = -75 %</li> <li>• P0761 = 0.1 V</li> <li>• P0756 = 0 or 1</li> </ul>							
<b>Index:</b>	See r0752							
<b>Notice:</b>	Deadband starts from 0 V to value of P0761, if both values of P0758 and P0760 (y coordinates of analog input scaling) are positive or negative respectively. However, deadband is active in both directions from point of intersection (x axis with analog input scaling curve), if sign of P0758 and P0760 are opposite.							
<b>Note:</b>	P0761[x] = 0: No deadband active. Minimum frequency P1080 should be zero when using center zero setup. There is no hysteresis at the end of the deadband.							
P0762[0...1]	<b>Delay for loss of signal action [ms]</b>	0 - 10000	10	U, T	-	-	U16	3
	Defines time delay between loss of analog setpoint and appearance of fault code F80.							
<b>Index:</b>	See r0752							
<b>Note:</b>	Expert users can choose the desired reaction to F80 (default is OFF2).							
r0770	<b>Number of analog output</b>	-	-	-	-	-	U16	3
	Displays number of analog outputs available.							
P0771[0]	<b>CI: Analog output</b>	0 - 4294967295	21[0]	U, T	-	-	U32	2
	Defines function of the analog output.							
<b>Index:</b>	[0]	Analog output 1 (AO1)						
<b>Setting:</b>	21	CO: Actual frequency (scaled to P2000)						
	24	CO: Actual output frequency (scaled to P2000)						
	25	CO: Actual output voltage (scaled to P2001)						
	26	CO: Actual DC-link voltage (scaled to P2001)						
	27	CO: Actual output current (scaled to P2002)						
P0773[0]	<b>Smooth time analog output [ms]</b>	0 - 1000	2	U, T	-	-	U16	2
	Defines smoothing time for analog output signal. This parameter enables smoothing for analog output using a PT1 filter.							
<b>Index:</b>	See P0771							
<b>Dependency:</b>	P0773 = 0: Deactivates filter.							

7.2 Parameter list

Parameter	Function	Range	Factory default	Can be changed	Scaling	Data set	Data type	Acc. Level
r0774[0]	<b>Actual analog output value [V] or [mA]</b>	-	-	-	-	-	Float	2
	Shows value of analog output after filtering and scaling.							
<b>Index:</b>	See P0771							
<b>Note:</b>	The analog output is only a current output. By connecting an external resistor of 500 Ω to the terminals (4/5) a voltage output with a range of 0 V to 10 V can be created.							
P0775[0]	<b>Permit absolute value</b>	0 - 1	0	T	-	-	U16	2
	Decides if the absolute value of the analog output is used. If enabled, this parameter will take the absolute value to be outputted. If the value was originally negative then the corresponding bit in r0785 is set, otherwise it is cleared.							
<b>Index:</b>	See P0771							
P0777[0]	<b>Value x1 of analog output scaling [%]</b>	-99999 - 99999	0.0	U, T	-	-	Float	2
	Defines x1 output characteristic. Scaling block is responsible for adjustment of output value defined in P0771 (analog output connector input). x1 is the first value of the two pairs of variants x1 / y1 and x2 / y2 which determine the straight line. The two points P1 (x1, y1) and P2 (x2, y2) can be chosen freely.							
<b>Note:</b>	See P0771							
<b>Dependency:</b>	See P0758							
P0778[0]	<b>Value y1 of analog output scaling</b>	0 - 20	0	U, T	-	-	Float	2
	Defines y1 of output characteristic.							
<b>Index:</b>	See P0771							
P0779[0]	<b>Value x2 of analog output scaling [%]</b>	-99999 - 99999	100.0	U, T	-	-	Float	2
	Defines x2 of output characteristic.							
<b>Index:</b>	See P0771							
<b>Dependency:</b>	See P0758							
P0780[0]	<b>Value y2 of analog output scaling</b>	0 - 20	20	U, T	-	-	Float	2
	Defines y2 of output characteristic.							
<b>Index:</b>	See P0771							
P0781[0]	<b>Width of analog output deadband</b>	0 - 20	0	U, T	-	-	Float	2
	Sets width of dead-band for analog output.							
<b>Index:</b>	See P0771							
r0785.0	<b>CO / BO: Status word of analog output</b>	-	-	-	-	-	U16	2
	Displays status of analog output. Bit 0 indicates that the value of analog output 1 is negative.							
	<b>Bit</b>	<b>Signal name</b>			<b>1 signal</b>		<b>0 signal</b>	
	00	Analog output 1 negative			Yes		No	
P0802	<b>Transfer data from EEPROM</b>	0 - 2	0	C(30)	-	-	U16	3
	Transfers values from inverter to External device when none 0. P0010 must be set to 30 for this to be possible.							

Parameter	Function	Range	Factory default	Can be changed	Scaling	Data set	Data type	Acc. Level
	0	Disabled						
	2	Start MMC Transfer						
<b>Note:</b>	Parameter is automatically reset to 0 (default) after transfer. P0010 will be reset to 0 on successful completion. Ensure that enough space exists on the MMC card before transferring data (8kb).							
P0803	<b>Transfer data to EEPROM</b>	0 - 2	0	C(30)	-	-	U16	3
	Transfers values from External to inverter when none 0. P0010 must be set to 30 for this to be possible. See P0802 for parameter values.							
<b>Note:</b>	Parameter is automatically reset to 0 (default) after transfer. P0010 will be reset to 0 on successful completion.							
P0804	<b>Select Clone file</b>	0 - 99	0	C(30)	-	-	U16	3
	Select clone file to up / down load. if P0804 = 0 then file name is clone00.bin if P0804 = 1 then file name is clone01.bin etc.							
P0806	<b>BI: Inhibit panel access</b>	0 - 4294967295	0	U, T	-	-	U32	3
	Binector input to lock control panel access through external client.							
r0807.0	<b>BO: Displays client access</b>	-	-	-	-	-	U16	3
	Binector output to display whether command and setpoint source is connected to an external client.							
	<b>Bit</b>	<b>Signal name</b>			<b>1 signal</b>		<b>0 signal</b>	
	00	Master control active			Yes		No	
P0809[0...2]	<b>Copy command data set (CDS)</b>	0 - 2	[0] 0 [1] 1 [2] 0	T	-	-	U16	2
	Calls 'Copy command data set (CDS)' function. The list of all command data sets (CDS) parameters is shown in "Index" at the end of the manual.							
<b>Example:</b>	Copying of all values from CDS0 to CDS2 can be accomplished by the following procedure: P0809[0] = 0 Copy from CDS0 P0809[1] = 2 Copy to CDS2 P0809[2] = 1 Start copy							
<b>Index:</b>	[0]	Copy from CDS						
	[1]	Copy to CDS						
	[2]	Start copy						
<b>Note:</b>	Start value in index 2 is automatically reset to '0' after execution of function.							
P0810	<b>BI: command data set bit 0 (Hand / Auto)</b>	0 - 4294967295	0	U, T	-	-	U32	2
	Selects command source from which to read Bit 0 for selecting a command data set (CDS). The actual selected CDS is displayed in r0054.15 (CDS bit 0) and r0055.15 (CDS bit 1). The actual active CDS is displayed in r0050.							
<b>Setting:</b>	722.0	Digital input 1 (requires P0701 to be set to 99, BICO)						
	722.1	Digital input 2 (requires P0702 to be set to 99, BICO)						
	722.2	Digital input 3 (requires P0703 to be set to 99, BICO)						

7.2 Parameter list

Parameter	Function	Range	Factory default	Can be changed	Scaling	Data set	Data type	Acc. Level
<b>Note:</b>	P0811 is also relevant for command data set (CDS) selection.							
P0811	<b>BI: command data set bit 1</b>	0 - 4294967295	0	U, T	-	-	U32	2
	Selects command source from which to read Bit 1 for selecting a command data set (see P0810).							
<b>Setting:</b>	See P0810.							
<b>Note:</b>	P0810 is also relevant for command data set (CDS) selection.							
P0819[0...2]	<b>Copy inverter data set (DDS)</b>	0 - 2	[0] 0 [1] 1 [2] 0	T	-	-	U16	2
	Calls 'Copy inverter data set (DDS)' function. The list of all inverter data set (DDS) parameters is shown in "Index" at the end of the manual.							
<b>Example:</b>	Copying of all values from DDS0 to DDS2 can be accomplished by the following procedure: P0819[0] = 0 Copy from DDS0 P0819[1] = 2 Copy to DDS2 P0819[2] = 1 Start copy							
<b>Index:</b>	[0]	Copy from DDS						
	[1]	Copy to DDS						
	[2]	Start copy						
<b>Note:</b>	See P0809							
P0820	<b>BI: inverter data set bit 0</b>	0 - 4294967295	0	T	-	-	U32	3
	Selects command source from which to read Bit 0 for selecting an inverter data set (DDS). The actual selected inverter data set (DDS) is displayed in parameter r0051[0]. The actual active inverter data set (DDS) is displayed in parameter r0051[1].							
<b>Setting:</b>	See P0810							
<b>Note:</b>	P0821 is also relevant for inverter data set (DDS) selection.							
P0821	<b>BI: inverter data set bit 1</b>	0 - 4294967295	0	T	-	-	U32	3
	Selects command source from which Bit 1 for selecting an inverter data set is to be read in (see P0820).							
<b>Setting:</b>	See P0810							
<b>Note:</b>	P0820 is also relevant for inverter data set (DDS) selection.							
P0840[0...2]	<b>BI: ON / OFF1</b>	0 - 4294967295	19.0	T	-	CDS	U32	3
	Allows ON / OFF1 command source to be selected using BICO. The digits in front of the colon show the parameter number of the command source; the digits following the colon denote the bit setting for that parameter.							
<b>Setting:</b>	See P0810							
<b>Dependency:</b>	For digital inputs as command source BICO requires P0700 set to 2 (enable BICO). The default setting (ON right) is digital input 1 (722.0). Alternative source possible only when function of digital input 1 is changed (via P0701) before changing value of P0840.							
P0842[0...2]	<b>BI: ON reverse / OFF1</b>	0 - 4294967295	0	T	-	CDS	U32	3
	Allows ON / OFF1 reverse command source to be selected using BICO. In general a positive frequency setpoint is run up counterclockwise (negative frequency).							
<b>Setting:</b>	See P0810							



Parameter	Function	Range	Factory default	Can be changed	Scaling	Data set	Data type	Acc. Level
P0843[0...2]	BI: ON/OFF2		1	T	-	CDS	U32 / Bin	3
	Allows ON/OFF2 command source to be selected using BICO. The default setting 1.0 will disable this parameter.							
<b>Dependency:</b>	For digital inputs as command source BICO requires P0700 set to 2 (enable BICO). If one of the digital inputs is selected for ON/OFF2, the inverter will not run unless the digital input is active. OFF2 means immediate pulse-disabling; the motor is coasting. OFF2 is low-active, i.e. :0 = Pulse disabling. 1 = Pulses enabled. (As long as there are no other OFF conditions active).							
<b>Note:</b>	ON/OFF2 functionality is not supported in 2/3 wire modes. Do not select ON/OFF2 unless P0727 = 0.							
P0844[0...2]	<b>BI: 1. OFF2</b>	0 - 4294967295	19.1	T	-	CDS	U32	3
	Defines first source of OFF2 when P0719 = 0 (BICO).							
<b>Setting:</b>	See P0810							
<b>Dependency:</b>	If one of the digital inputs is selected for OFF2, the inverter will not run unless the digital input is active.							
<b>Note:</b>	OFF2 means immediate pulse-disabling; the motor is coasting. OFF2 is low-active, i.e.: 0 = Pulse disabling. 1 = Operating condition.							
P0845[0...2]	<b>BI: 2. OFF2</b>	0 - 4294967295	1	T	-	CDS	U32	3
	Defines second source of OFF2.							
<b>Setting:</b>	See P0810							
<b>Dependency:</b>	In contrast to P0844 (first source of OFF2), this parameter is always active, independent of P0719 (selection of command and frequency setpoint). See P0844.							
<b>Note:</b>	See P0844							
P0848[0...2]	<b>BI: 1. OFF3</b>	0 - 4294967295	1	T	-	CDS	U32	3
	Defines first source of OFF3 when P0719 = 0 (BICO).							
<b>Setting:</b>	See P0810							
<b>Dependency:</b>	If one of the digital inputs is selected for OFF3, the inverter will not run unless the digital input is active.							
<b>Note:</b>	OFF3 means quick ramp-down to 0. OFF3 is low-active, i.e. 0 = Quick ramp-down. 1 = Operating condition.							
P0849[0...2]	<b>BI: 2. OFF3</b>	0 - 4294967295	1	T	-	CDS	U32	3
	Defines second source of OFF3.							
<b>Setting:</b>	See P0810							
<b>Dependency:</b>	In contrast to P0848 (first source of OFF3), this parameter is always active, independent of P0719 (selection of command and frequency setpoint). See P0848.							
<b>Note:</b>	See P0848							
P0852[0...2]	<b>BI: Pulse enable</b>	0 - 4294967295	1	T	-	CDS	U32	3
	Defines source of pulse enable / disable signal.							
<b>Setting:</b>	See P0810							

Parameter list

7.2 Parameter list

Parameter	Function	Range	Factory default	Can be changed	Scaling	Data set	Data type	Acc. Level
<b>Dependency:</b>	Active only when P0719 = 0 (Auto selection of command / setpoint source).							
P0881[0...2]	<b>BI: Quick stop source 1</b>	0 - 4294967295	1	T	-	CDS	U32	3
	Allows quick stop source 1 command to be selected using BICO. The signal is expected to be active low (default setting P0886 = 2).							
<b>Setting:</b>	See P0810							
P0882[0...2]	<b>BI: Quick stop source 2</b>	0 - 4294967295	1	T	-	CDS	U32	3
	Allows quick stop source 2 command to be selected using BICO. The signal is expected to be active low (default setting P0886 = 2).							
<b>Setting:</b>	See P0810							
P0883[0...2]	<b>BI: Quick stop override</b>	0 - 4294967295	0	T	-	CDS	U32	3
	Allows quick stop override command source to be selected using BICO. The signal is expected to be active high.							
<b>Setting:</b>	See P0810							
P0886[0...2]	<b>Quick stop input type</b>	0 - 4	2	T	-	CDS	U16	3
	Control Word for selecting the quick stop input type.							
	0	Quick stop not selected						
	1	Quick stop input active high						
	2	Quick stop input active low						
	3	Quick stop input positive edge triggered						
	4	Quick stop input negative edge triggered						
P0927	<b>Parameter changeable via specified interfaces</b>	0 - 15	15	U, T	-	-	U16	2
	Specifies the interfaces which can be used to change parameters. This parameter allows the user to easily protect the inverter from unauthorized modification of parameters. Annotation: P0927 is not password protected.							
	<b>Bit</b>	<b>Signal name</b>			<b>1 signal</b>		<b>0 signal</b>	
	00	Not used			Yes		No	
	01	Not used			Yes		No	
	02	USS on RS232 (reserved)			Yes		No	
	03	USS/MODBUS on RS485			Yes		No	
<b>Example:</b>	Default: All bits are set. The default setting allows parameters to be changed via any interface.							
r0944	<b>Total number of messages</b>	-	-	-	-	-	U16	3
	Displays the total number of messages available.							
r0947[0...63]	<b>CO: Last fault code</b>	-	-	-	-	-	U16	2

Parameter	Function	Range	Factory default	Can be changed	Scaling	Data set	Data type	Acc. Level
	<p>Displays fault history.</p>							
<b>Index:</b>	[0]	Recent fault trip --, fault 1						
	...	...						
	[7]	Recent fault trip --, fault 8						
	[8]	Recent fault trip -1, fault 1						
	...	...						
	[15]	Recent fault trip -1, fault 8						
	[16]	Recent fault trip -2, fault 1						
	...	...						
	[23]	Recent fault trip -2, fault 8						
	...	...						
	[63]	Recent fault trip -7, fault 8						
<b>Notice:</b>	It is possible that this parameter is empty but a fault is still indicated by the inverter. The reason for this is most likely due to a SAFE condition still existing in the system. In this situation the fault is cleared from this parameter and it makes no sense to go back to a READY state. First remove the reason for the SAFE condition and then the inverter will be able to change to a READY state (SAFE condition example is "safety function is activated").							
<b>Note:</b>	The function "inverter status at fault" (Page 281) serves as a snapshot record in time of the relative parameters being monitored at the point of a fault occurring. Some recorded parameters are filtered values. Therefore if a hardware trip occurs, (r0949 = 0), some filtered values may not appear to reflect those values which caused the trip.							
<b>Example:</b>	If a hardware overvoltage trip occurs, (r0947 = 2 and r0949 = 0), the value of the filtered DC link voltage in r0956 may appear to be under the trip limit. In this case, the filtered DC link value had not had enough time to rise to the trip level; however, the actual limit had been exceeded and hence the hardware had tripped to protect itself.							
r0948[0...63]	<b>Fault time</b>	-	-	-	-	-	U32	3
	Time stamp to indicate when a fault has occurred. P0969 (system run time counter) is the possible source of the time stamp.							
<b>Index:</b>	[0]	Recent fault trip --, fault time 1						

Parameter list

7.2 Parameter list

Parameter	Function	Range	Factory default	Can be changed	Scaling	Data set	Data type	Acc. Level
	...	...						
	[7]	Recent fault trip --, fault time 8						
	[8]	Recent fault trip -1, fault time 1						
	...	...						
	[15]	Recent fault trip -1, fault time 8						
	[16]	Recent fault trip -2, fault time 1						
	...	...						
	[23]	Recent fault trip -2, fault time 8						
	...	...						
	[63]	Recent fault trip -7, fault time 8						
r0949[0...63]	<b>CO: Fault value</b>	-	-	-	-	-	U32	3
	Displays inverter fault values. It is for service purposes and indicates the type of fault reported. The values are not documented. They are listed in the code where faults are reported.							
<b>Index:</b>	[0]	Recent fault trip --, fault value 1						
	...	...						
	[7]	Recent fault trip --, fault value 8						
	[8]	Recent fault trip -1, fault value 1						
	...	...						
	[15]	Recent fault trip -1, fault value 8						
	[16]	Recent fault trip -2, fault value 1						
	...	...						
	[23]	Recent fault trip -2, fault value 8						
	...	...						
	[63]	Recent fault trip -7, fault value 8						
P0952	<b>Total number of trips</b>	0 - 65535	0	T	-	-	U16	3
	Displays number of trips stored in r0947 (last fault code).							
<b>Dependency:</b>	Setting 0 resets fault history (changing to 0 also resets r0948 - fault time).							
<b>Note:</b>	If the source of a non-momentary fault remains active before a factory reset, the inverter removes the source first and then places the fault into the fault history during a factory reset. That means P0952 still has a non-zero value after the factory reset. If you want to clear the fault history, you need to perform a second factory reset or set P0952 = 0.							
r0954[0...2]	<b>CO: Freq. setpoint after RFG at fault</b>	-	-	-	-	-	Float	3
	Displays the setpoint after RFG when the first instantaneous fault occurs (see r1170).							
<b>Index:</b>	[0]	Recent trip - Fault information						
	[1]	Recent trip - 1 Fault information						
	[2]	Recent trip - 2 Fault information						
<b>Note:</b>	Only one set of fault information is stored per block of instantaneous faults. r0954[0] corresponds to r0947[0...7], r0954[1] corresponds to r0947[8...15] and r0954[2] corresponds to r0947[16...23].							
r0955[0...2]	<b>CO/BO: Status word 2 at fault</b>	-	-	-	-	-	U16	3
	Displays status word 2 when the first instantaneous fault occurs (see r0053).							
<b>Index:</b>	[0]	Recent trip - Fault information						

Parameter	Function	Range	Factory default	Can be changed	Scaling	Data set	Data type	Acc. Level
	[1]	Recent trip - 1 Fault information						
	[2]	Recent trip - 2 Fault information						
<b>Note:</b>	Only one set of fault information is stored per block of instantaneous faults. r0955[0] corresponds to r0947[0...7], r0955[1] corresponds to r0947[8...15] and r0955[2] corresponds to r0947[16...23].							
r0956[0...2]	<b>CO: DC-link voltage at fault</b>	-	-	-	-	-	Float	3
	Displays the DC link voltage when the first instantaneous fault occurs (see r0026).							
<b>Index:</b>	[0]	Recent trip - Fault information						
	[1]	Recent trip - 1 Fault information						
	[2]	Recent trip - 2 Fault information						
<b>Note:</b>	Only one set of fault information is stored per block of instantaneous faults. r0956[0] corresponds to r0947[0...7], r0956[1] corresponds to r0947[8...15] and r0956[2] corresponds to r0947[16...23].							
r0957[0...2]	<b>CO: Act. output current at fault</b>	-	-	-	-	-	Float	3
	Displays the output current RMS when the first instantaneous fault occurs (see r0027).							
<b>Index:</b>	[0]	Recent trip - Fault information						
	[1]	Recent trip - 1 Fault information						
	[2]	Recent trip - 2 Fault information						
<b>Note:</b>	Only one set of fault information is stored per block of instantaneous faults. r0957[0] corresponds to r0947[0...7], r0957[1] corresponds to r0947[8...15] and r0957[2] corresponds to r0947[16...23].							
r0958[0...2]	<b>CO: Act. output voltage at fault</b>	-	-	-	-	-	Float	3
	Displays the output voltage when the first instantaneous fault occurs (see r0025).							
<b>Index:</b>	[0]	Recent trip - Fault information						
	[1]	Recent trip - 1 Fault information						
	[2]	Recent trip - 2 Fault information						
<b>Note:</b>	Only one set of fault information is stored per block of instantaneous faults. r0958[0] corresponds to r0947[0...7], r0958[1] corresponds to r0947[8...15] and r0958[2] corresponds to r0947[16...23].							
r0964[0...6]	<b>Firmware version data</b>	-	-	-	-	-	U16	3
	Firmware version data.							
<b>Index:</b>	[0]	Company (Siemens = 42)						
	[1]	Product type (V20 = 8001)						
	[2]	Firmware version						
	[3]	Firmware date (year)						
	[4]	Firmware date (day / month)						
	[5]	Number of inverter objects						
	[6]	Firmware version						
r0967	<b>Control word 1</b>	-	-	-	-	-	U16	3
	Displays control word 1. See r0054 for the bit field description.							
r0968	<b>Status word 1</b>	-	-	-	-	-	U16	3
	Displays active status word of inverter (in binary) and can be used to diagnose which commands are active. See r0052 for the bit field description.							

Parameter list

7.2 Parameter list

Parameter	Function	Range	Factory default	Can be changed	Scaling	Data set	Data type	Acc. Level
P0969	<b>Resettable system run time counter</b>	0 - 4294967295	0	T	-	-	U32	3
	Resettable system run time counter.							
P0970	<b>Factory reset</b>	0 - 21	0	C(30)	-	-	U16	1
	P0970 = 1 resets all parameters (not user defaults) to their default values. P0970 = 21 resets all parameters and all user defaults to Factory Reset state.							
	0	Disabled						
	1	Parameter reset						
	21	User Default Parameter Reset						
<b>Dependency:</b>	First set P0010 = 30 (factory settings). Stop inverter (i.e. disable all pulses) before you can reset parameters to default values.							
<b>Note:</b>	<p>The following parameters retain their values after a factory reset:</p> <ul style="list-style-type: none"> <li>• r0039 CO: Energy consumption meter [kWh]</li> <li>• P0014 Store mode</li> <li>• P0100 Europe / North America</li> <li>• P0205 Inverter application</li> <li>• P2010 USS / MODBUS baudrate</li> <li>• P2011 USS address</li> <li>• P2021 MODBUS address</li> <li>• P2023 RS485 protocol selection</li> <li>• P8458 Clone control</li> </ul> <p>When transferring P0970, the inverter uses its processor to carry out internal calculations. Communications are interrupted for the time that it takes to make these calculations.</p>							
P0971	<b>Transfer data from RAM to EEPROM</b>	0 - 21	0	U, T	-	-	U16	3
	Transfers values from RAM to EEPROM when set to 1. Transfers new user default values from RAM to EEPROM when set to 21.							
	0	Disabled						
	1	Start transfer						
	21	Start User Defaults transfer						
<b>Note:</b>	<p>All values in RAM are transferred to EEPROM. Parameter is automatically reset to 0 (default) after successful transfer. The storage from RAM to EEPROM is accomplished via P0971. The communications are reset, if the transfer was successful. During the reset process communications will be interrupted.</p> <ul style="list-style-type: none"> <li>• BOP displays 88888</li> </ul> <p>After completion of the transfer process, the communication between the inverter and external peripherals (BOP, USS or Modbus Master) is automatically re-established.</p>							
r0980[0...99]	<b>List of available parameter numbers</b>	0 - 65535	981	-	-	-	U16	4
	Contains 100 parameter numbers index 0 - 99.							
<b>Index:</b>	[0]	Parameter 1						
	[1]	Parameter 2						

Parameter	Function	Range	Factory default	Can be changed	Scaling	Data set	Data type	Acc. Level
	...	...						
	[98]	Parameter 99						
	[99]	Next parameter list						
<b>Note:</b>	The parameter list array has 2 elements to reduce memory consumption. On each access to an element index 0 - 99, the individual result is determined dynamically by the 'BeforeAccess' function. The last element contains the number of the following parameter array, 0 indicates end of list.							
r0981[0...99]	<b>List of available parameter numbers</b>	0 - 65535	982	-	-	-	U16	4
	Contains 100 parameter numbers index 100 - 199.							
<b>Index:</b>	See r0980							
<b>Note:</b>	See r0980							
r0982[0...99]	<b>List of available parameter numbers</b>	0 - 65535	983	-	-	-	U16	4
	Contains 100 parameter numbers index 200 - 299.							
<b>Index:</b>	See r0980							
<b>Note:</b>	See r0980							
r0983[0...99]	<b>List of available parameter numbers</b>	0 - 65535	984	-	-	-	U16	4
	Contains 100 parameter numbers index 300 - 399.							
<b>Index:</b>	See r0980							
<b>Note:</b>	See r0980							
r0984[0...99]	<b>List of available parameter numbers</b>	0 - 65535	985	-	-	-	U16	4
	Contains 100 parameter numbers index 400 - 499.							
<b>Index:</b>	See r0980							
<b>Note:</b>	See r0980							
r0985[0...99]	<b>List of available parameter numbers</b>	0 - 65535	986	-	-	-	U16	4
	Contains 100 parameter numbers index 500 - 599.							
<b>Index:</b>	See r0980							
<b>Note:</b>	See r0980							
r0986[0...99]	<b>List of available parameter numbers</b>	0 - 65535	987	-	-	-	U16	4
	Contains 100 parameter numbers index 600 - 699.							
<b>Index:</b>	See r0980							
<b>Note:</b>	See r0980							
r0987[0...99]	<b>List of available parameter numbers</b>	0 - 65535	988	-	-	-	U16	4
	Contains 100 parameter numbers index 700 - 799.							
<b>Index:</b>	See r0980							
<b>Note:</b>	See r0980							

7.2 Parameter list

Parameter	Function	Range	Factory default	Can be changed	Scaling	Data set	Data type	Acc. Level
r0988[0...99]	<b>List of available parameter numbers</b>	0 - 65535	989	-	-	-	U16	4
	Contains 100 parameter numbers index 800 - 899.							
<b>Index:</b>	See r0980							
<b>Note:</b>	See r0980							
r0989[0...99]	<b>List of available parameter numbers</b>	0 - 65535	0	-	-	-	U16	4
	Contains 100 parameter numbers index 900 - 999.							
<b>Index:</b>	See r0980							
<b>Note:</b>	See r0980							
P1000[0...2]	<b>Selection of frequency setpoint</b>	0 - 77	1	C, T	-	CDS	U16	1
	<p>Selects frequency setpoint source. The main setpoint is given by the least significant digit (right-hand position) and the additional setpoint is given by the most significant digit (left-hand position). Single digits denote main setpoints that have no additional setpoint.</p> <p>Run command</p>							
	0	No main setpoint						
	1	MOP setpoint						
	2	Analog setpoint						
	3	Fixed frequency						
	5	USS/MODBUS on RS485						
	7	Analog setpoint 2						
	10	No main setpoint + MOP setpoint						
	11	MOP setpoint + MOP setpoint						
	12	Analog setpoint + MOP setpoint						
	13	Fixed frequency + MOP setpoint						
	15	USS/MODBUS on RS485 + MOP setpoint						



Parameter	Function	Range	Factory default	Can be changed	Scaling	Data set	Data type	Acc. Level
	17	Analog setpoint 2 + MOP setpoint						
	20	No main setpoint + Analog setpoint						
	21	MOP setpoint + Analog setpoint						
	22	Analog setpoint + Analog setpoint						
	23	Fixed frequency + Analog setpoint						
	25	USS/MODBUS on RS485 + Analog setpoint						
	27	Analog setpoint 2 + Analog setpoint						
	30	No main setpoint + Fixed frequency						
	31	MOP setpoint + Fixed frequency						
	32	Analog setpoint + Fixed frequency						
	33	Fixed frequency + Fixed frequency						
	35	USS/MODBUS on RS485 + Fixed frequency						
	37	Analog setpoint 2 + Fixed frequency						
	50	No main setpoint + USS/MODBUS on RS485						
	51	MOP setpoint + USS/MODBUS on RS485						
	52	Analog setpoint + USS/MODBUS on RS485						
	53	Fixed frequency + USS/MODBUS on RS485						
	55	USS/MODBUS on RS485 + USS/MODBUS on RS485						
	57	Analog setpoint 2 + USS/MODBUS on RS485						
	70	No main setpoint + Analog setpoint 2						
	71	MOP setpoint + Analog setpoint 2						
	72	Analog setpoint + Analog setpoint 2						
	73	Fixed frequency + Analog setpoint 2						
	75	USS/MODBUS on RS485 + Analog setpoint 2						
	77	Analog setpoint 2 + Analog setpoint 2						
<b>Dependency:</b>	Related parameter: P1074 (BI: Disable additional setpoint)							
<b>Caution:</b>	Changing this parameter sets (to default) all settings on item selected. These are the following parameters: P1070, P1071, P1075, P1076 If P1000 = 1 or 1X, and P1032 (inhibit reverse direction of MOP) = 1, then reverse motor direction will be inhibited.							
<b>Note:</b>	RS485 also supports MODBUS protocol as well as USS. All USS options on RS485 are also applicable to MODBUS. To alter the setpoint using the BOP when the command source P0700 is not set to 1, you must check that P1035 is set to r0019 bit 13 and P1036 is set to r0019 bit 14.							
P1001[0...2]	<b>Fixed frequency 1 [Hz]</b>	-599.00 - 550.00	10.00	U, T	-	DDS	Float	2

Parameter list

7.2 Parameter list

Parameter	Function	Range	Factory default	Can be changed	Scaling	Data set	Data type	Acc. Level
	Defines fixed frequency setpoint 1. There are 2 types of fixed frequencies: <ul style="list-style-type: none"> <li>• Direct selection (P1016 = 1):                             <ul style="list-style-type: none"> <li>– In this mode of operation 1 Fixed Frequency selector (P1020 to P1023) selects 1 fixed frequency.</li> <li>– If several inputs are active together, the selected frequencies are summed. E.g.: FF1 + FF2 + FF3 + FF4.</li> </ul> </li> <li>• Binary coded selection (P1016 = 2):                             <ul style="list-style-type: none"> <li>– Up to 16 different fixed frequency values can be selected using this method.</li> </ul> </li> </ul>							
<b>Dependency:</b>	Select fixed frequency operation (using P1000). Inverter requires ON command to start in the case of direct selection. Therefore r1025 must be connected to P0840 to start.							
<b>Note:</b>	Fixed frequencies can be selected using the digital inputs.							
P1002[0...2]	<b>Fixed frequency 2 [Hz]</b>	-599.00 - 550.00	15.00	U, T	-	DDS	Float	2
	Defines fixed frequency setpoint 2.							
<b>Note:</b>	See P1001							
P1003[0...2]	<b>Fixed frequency 3 [Hz]</b>	-599.00 - 550.00	25.00	U, T	-	DDS	Float	2
	Defines fixed frequency setpoint 3.							
<b>Note:</b>	See P1001							
P1004[0...2]	<b>Fixed frequency 4 [Hz]</b>	-599.00 - 550.00	50.00	U, T	-	DDS	Float	2
	Defines fixed frequency setpoint 4.							
<b>Note:</b>	See P1001							
P1005[0...2]	<b>Fixed frequency 5 [Hz]</b>	-599.00 - 550.00	0.00	U, T	-	DDS	Float	2
	Defines fixed frequency setpoint 5.							
<b>Note:</b>	See P1001							
P1006[0...2]	<b>Fixed frequency 6 [Hz]</b>	-599.00 - 550.00	0.00	U, T	-	DDS	Float	2
	Defines fixed frequency setpoint 6.							
<b>Note:</b>	See P1001							
P1007[0...2]	<b>Fixed frequency 7 [Hz]</b>	-599.00 - 550.00	0.00	U, T	-	DDS	Float	2
	Defines fixed frequency setpoint 7.							
<b>Note:</b>	See P1001							
P1008[0...2]	<b>Fixed frequency 8 [Hz]</b>	-599.00 - 550.00	0.00	U, T	-	DDS	Float	2
	Defines fixed frequency setpoint 8.							
<b>Note:</b>	See P1001							
P1009[0...2]	<b>Fixed frequency 9 [Hz]</b>	-599.00 - 550.00	0.00	U, T	-	DDS	Float	2
	Defines fixed frequency setpoint 9.							
<b>Note:</b>	See P1001							

Parameter	Function	Range	Factory default	Can be changed	Scaling	Data set	Data type	Acc. Level
P1010[0...2]	<b>Fixed frequency 10 [Hz]</b>	-599.00 - 550.00	0.00	U, T	-	DDS	Float	2
	Defines fixed frequency setpoint 10.							
<b>Note:</b>	See P1001							
P1011[0...2]	<b>Fixed frequency 11 [Hz]</b>	-599.00 - 550.00	0.00	U, T	-	DDS	Float	2
	Defines fixed frequency setpoint 11.							
<b>Note:</b>	See P1001							
P1012[0...2]	<b>Fixed frequency 12 [Hz]</b>	-599.00 - 550.00	0.00	U, T	-	DDS	Float	2
	Defines fixed frequency setpoint 12.							
<b>Note:</b>	See P1001							
P1013[0...2]	<b>Fixed frequency 13 [Hz]</b>	-599.00 - 550.00	0.00	U, T	-	DDS	Float	2
	Defines fixed frequency setpoint 13.							
<b>Note:</b>	See P1001							
P1014[0...2]	<b>Fixed frequency 14 [Hz]</b>	-599.00 - 550.00	0.00	U, T	-	DDS	Float	2
	Defines fixed frequency setpoint 14.							
<b>Note:</b>	See P1001							
P1015[0...2]	<b>Fixed frequency 15 [Hz]</b>	-599.00 - 550.00	0.00	U, T	-	DDS	Float	2
	Defines fixed frequency setpoint 15.							
<b>Note:</b>	See P1001							
P1016[0...2]	<b>Fixed frequency mode</b>	1 - 2	1	T	-	DDS	U16	2
	Fixed frequencies can be selected in two different modes. P1016 defines the mode.							
	1	Direct selection						
	2	Binary selection						
<b>Note:</b>	See P1001 for description of how to use fixed frequencies.							
P1020[0...2]	<b>BI: Fixed frequency selection Bit 0</b>	0 - 4294967295	722.3	T	-	CDS	U32	3
	Defines origin of fixed frequency selection.							
<b>Setting:</b>	722.0	Digital input 1 (requires P0701 to be set to 99, BICO)						
	722.1	Digital input 2 (requires P0702 to be set to 99, BICO)						
	722.2	Digital input 3 (requires P0703 to be set to 99, BICO)						
<b>Dependency:</b>	Accessible only if P0701 - P070x = 99 (function of digital inputs = BICO)							
P1021[0...2]	<b>BI: Fixed frequency selection Bit 1</b>	0 - 4294967295	722.4	T	-	CDS	U32	3
	See P1020							
P1022[0...2]	<b>BI: Fixed frequency selection Bit 2</b>	0 - 4294967295	722.5	T	-	CDS	U32	3
	See P1020							

Parameter list

7.2 Parameter list

Parameter	Function	Range	Factory default	Can be changed	Scaling	Data set	Data type	Acc. Level
P1023[0...2]	<b>BI: Fixed frequency selection Bit 3</b>	0 - 4294967295	722.6	T	-	CDS	U32	3
	See P1020							
r1024	<b>CO: Actual fixed frequency [Hz]</b>	-	-	-	-	-	Float	3
	Displays sum total of selected fixed frequencies.							
r1025.0	<b>BO: Fixed frequency status</b>	-	-	-	-	-	U16	3
	Displays the status of fixed frequencies.							
	<b>Bit</b>	<b>Signal name</b>			<b>1 signal</b>		<b>0 signal</b>	
	00	Status of FF			Yes		No	
P1031[0...2]	<b>MOP mode</b>	0 - 3	1	U, T	-	DDS	U16	2
	MOP mode specification.							
	<b>Bit</b>	<b>Signal name</b>			<b>1 signal</b>		<b>0 signal</b>	
	00	Setpoint store active			Yes		No	
	01	No On-state for MOP necessary			Yes		No	
<b>Note:</b>	Defines the operation mode of the motorized potentiometer. See P1040.							
P1032	<b>Inhibit reverse direction of MOP</b>	0 - 1	1	T	-	-	U16	2
	Inhibits reverse setpoint selection of the MOP.							
	0	Reverse direction is allowed						
	1	Reverse direction inhibited						
<b>Note:</b>	It is possible to change motor direction using the motor potentiometer setpoint (increase / decrease frequency). Setting 0 enables a change of motor direction using the motor potentiometer setpoint (increase / decrease frequency). If P1032 = 1 and P1000 = 1 or 1X, then reverse motor direction will be inhibited.							
P1035[0...2]	<b>BI: Enable MOP (UP-command)</b>	0 - 4294967295	19.13	T	-	CDS	U32	3
	Defines source for motor potentiometer setpoint increase frequency.							
<b>Setting:</b>	722.0	Digital input 1 (requires P0701 to be set to 99, BICO)						
	722.1	Digital input 2 (requires P0702 to be set to 99, BICO)						
	722.2	Digital input 3 (requires P0703 to be set to 99, BICO)						
<b>Notice:</b>	If this command is enabled by short pulses of less than 1 second, the frequency is changed in steps of 0.1 Hz. When the signal is enabled longer than 1 second the ramp generator accelerates with the rate of P1047.							
P1036[0...2]	<b>BI: Enable MOP (DOWN-command)</b>	0 - 4294967295	19.14	T	-	CDS	U32	3
	Defines source for motor potentiometer setpoint decrease frequency.							
<b>Setting:</b>	See P1035							
<b>Notice:</b>	If this command is enabled by short pulses of less than 1 second, the frequency is changed in steps of 0.1 Hz. When the signal is enabled longer than 1 second the ramp generator decelerates with the rate of P1048.							

Parameter	Function	Range	Factory default	Can be changed	Scaling	Data set	Data type	Acc. Level
P1040[0...2]	<b>Setpoint of the MOP [Hz]</b>	-599.00 - 550.00	5.00	U, T	-	DDS	Float	2
	Determines setpoint for motor potentiometer control (P1000 = 1).							
<b>Dependency:</b>	Motor potentiometer (P1040) must be chosen as main setpoint or additional setpoint (using P1000).							
<b>Note:</b>	<p>If motor potentiometer setpoint is selected either as main setpoint or additional setpoint, the reverse direction will be inhibited by default of P1032 (inhibit reverse direction of MOP). To re-enable reverse direction, set P1032 = 0.</p> <p>A short press of the 'up' or 'down' keys (e.g.: operator panel) will change the frequency setpoint in steps of 0.1 Hz. A longer press will cause an accelerated frequency setpoint change.</p> <p>The start value gets active (for the MOP output) only at the start of the MOP. P1031 influences the start value behavior as follows:</p> <ul style="list-style-type: none"> <li>• P1031 = 0: Last MOP setpoint not saved in P1040 MOP UP/DOWN requires an ON command to become active.</li> <li>• P1031 = 1: Last MOP setpoint saved in P1040 on every OFF MOP UP/DOWN requires an ON command to become active (default).</li> <li>• P1031 = 2: Last MOP setpoint not saved in P1040 MOP UP/DOWN active without additional ON command.</li> <li>• P1031 = 3: Last MOP setpoint saved in P1040 on powering-up MOP UP/DOWN active without additional ON command.</li> </ul>							
P1041[0...2]	<b>BI: MOP select setpoint automatically / manually</b>	0 - 4294967295	0	T	-	CDS	U32	3
	Sets the signal source to change over from manual to automatic mode. If using the motorized potentiometer in the manual mode the setpoint is changed using two signals for up and down e.g. P1035 and P1036. If using the automatic mode the setpoint must be interconnected via the connector input (P1042). 0: manually 1: automatically							
<b>Notice:</b>	Refer to: P1035, P1036, P1042							
P1042[0...2]	<b>CI: MOP auto setpoint</b>	0 - 4294967295	0	T	-	CDS	U32	3
	Sets the signal source for the setpoint of the motorized potentiometer if automatic mode P1041 is selected.							
<b>Notice:</b>	Refer to: P1041							
P1043[0...2]	<b>BI: MOP accept rampgenerator setpoint</b>	0 - 4294967295	0	T	-	CDS	U32	3
	Sets the signal source for the setting command to accept the setting value for the motorized potentiometer. The value becomes effective for a 0 / 1 edge of the setting command.							
<b>Notice:</b>	Refer to: P1044							
P1044[0...2]	<b>CI: MOP rampgenerator setpoint</b>	0 - 4294967295	0	T	-	CDS	U32	3
	Sets the signal source for the setpoint value for the MOP. The value becomes effective for a 0 / 1 edge of the setting command.							
<b>Notice:</b>	Refer to: P1043							
r1045	<b>CO: MOP input frequency of the RFG [Hz]</b>	-	-	-	-	-	Float	3

Parameter list

7.2 Parameter list

Parameter	Function	Range	Factory default	Can be changed	Scaling	Data set	Data type	Acc. Level
	Displays the motorized potentiometer setpoint before it passed the MOP RFG.							
P1047[0...2]	<b>MOP ramp-up time of the RFG [s]</b>	0.00 - 1000.00	10.00	U, T	-	DDS	Float	2
	Sets the ramp-up time for the internal MOP ramp-function generator. The setpoint is changed from zero up to limit defined in P1082 within this time.							
<b>Notice:</b>	Refer to: P1048, P1082							
P1048[0...2]	<b>MOP ramp-down time of the RFG [s]</b>	0.00 - 1000.0	10.00	U, T	-	DDS	Float	2
	Sets the ramp-down time for the internal MOP ramp-function generator. The setpoint is changed from limit defined in P1082 down to zero within this time.							
<b>Notice:</b>	Refer to: P1047, P1082							
r1050	<b>CO: Actual output freq. of the MOP [Hz]</b>	-	-	-	-	-	Float	2
	Displays output frequency of motor potentiometer setpoint.							
P1055[0...2]	<b>BI: Enable JOG right</b>	0 - 4294967295	19.8	T	-	CDS	U32	3
	Defines source of JOG right when P0719 = 0 (Auto selection of command / setpoint source).							
P1056[0...2]	<b>BI: Enable JOG left</b>	0 - 4294967295	0	T	-	CDS	U32	3
	Defines source of JOG left when P0719 = 0 (Auto selection of command / setpoint source).							
P1057	<b>JOG enable</b>	0 - 1	1	T	-	-	U16	3
	While JOG enable is '0' Jogging (P1056 and P1055) is disabled. When '1' Jogging is enabled.							
P1058[0...2]	<b>JOG frequency [Hz]</b>	0.00 - 550.00	5.00	U, T	-	DDS	Float	2
	Jogging increases the motor speed by small amounts. The JOG mode allows the operator to perform a specific number of revolutions and position the rotor manually. In JOG mode, the RUN button on the operator panel for jogging uses a non-latching switch on one of the digital inputs to control the motor speed. While jogging, P1058 determines the frequency at which the inverter will run. The motor speed is increased as long as 'JOG left' or 'JOG right' are selected and until the left or right JOG frequency is reached.							
<b>Dependency:</b>	P1060 and P1061 set up and down ramp times respectively for jogging. Rounding times (P1130 - P1133), rounding type (P1134) and P2167 will also have influence on the JOG ramp.							
P1059[0...2]	<b>JOG frequency left [Hz]</b>	0.00 - 550.00	5.00	U, T	-	DDS	Float	2
	While JOG left is selected, this parameter determines the frequency at which the inverter will run.							
<b>Dependency:</b>	P1060 and P1061 set up and down ramp times respectively for jogging.							
P1060[0...2]	<b>JOG ramp-up time [s]</b>	0.00 - 650.00	10.00	U, T	-	DDS	Float	2
	Sets jog ramp-up time. This is the time used while jogging is active.							
<b>Dependency:</b>	See also P3350, P3353.							
<b>Notice:</b>	Ramp times will be used as follows: <ul style="list-style-type: none"> <li>• P1060 / P1061 : JOG mode is active</li> <li>• P1120 / P1121 : Normal mode (ON / OFF) is active</li> <li>• P1060 / P1061 : Normal mode (ON / OFF) and P1124 is active</li> </ul> The rounding of P1130 - P1133 also applies to the JOG ramping.							

Parameter	Function	Range	Factory default	Can be changed	Scaling	Data set	Data type	Acc. Level
<b>Note:</b>	If the SuperTorque function is enabled, the inverter will initially ramp using the value in P3353.							
P1061[0...2]	<b>JOG ramp-down time [s]</b>	0.00 - 650.00	10.00	U, T	-	DDS	Float	2
	Sets ramp-down time. This is the time used while jogging is active.							
<b>Dependency:</b>	See also P3350, P3353.							
<b>Note:</b>	See P1060							
P1070[0...2]	<b>CI: Main setpoint</b>	0 - 4294967295	1050[0]	T	-	CDS	U32	3
	Defines source of main setpoint.							
<b>Setting:</b>	755	Analog input 1 setpoint						
	1024	Fixed frequency setpoint						
	1050	Motor potentiometer (MOP) setpoint						
P1071[0...2]	<b>CI: Main setpoint scaling</b>	0 - 4294967295	1	T	4000H	CDS	U32	3
	Defines source of the main setpoint scaling.							
<b>Setting:</b>	See P1070							
P1074[0...2]	<b>BI: Disable additional setpoint</b>	0 - 4294967295	0	U, T	-	CDS	U32	3
	Disables additional setpoint.							
<b>Setting:</b>	See P1070							
P1075[0...2]	<b>CI: Additional setpoint</b>	0 - 4294967295	0	T	-	CDS	U32	3
	Defines source of the additional setpoint (to be added to main setpoint).							
<b>Setting:</b>	See P1070							
P1076[0...2]	<b>CI: Additional setpoint scaling</b>	0 - 4294967295	1	T	4000H	CDS	U32	3
	Defines source of scaling for additional setpoint (to be added to main setpoint).							
<b>Setting:</b>	1	Scaling of 1.0 (100%)						
	755	Analog input 1 setpoint						
	1024	Fixed frequency setpoint						
	1050	MOP setpoint						
r1078	<b>CO: Total frequency setpoint [Hz]</b>	-	-	-	-	-	Float	3
	Displays sum of main and additional setpoints.							
r1079	<b>CO: Selected frequency setpoint [Hz]</b>	-	-	-	-	-	Float	3
	Displays selected frequency setpoint. Following frequency setpoints are displayed: <ul style="list-style-type: none"> <li>• r1078 Total frequency setpoint</li> <li>• P1058 JOG frequency right</li> <li>• P1059 JOG frequency left</li> </ul>							
<b>Dependency:</b>	P1055 (BI: Enable JOG right) or P1056 (BI: Enable JOG left) define command source of JOG right or JOG left respectively.							
<b>Note:</b>	P1055 = 0 and P1056 = 0 ==> Total frequency setpoint is selected.							

Parameter	Function	Range	Factory default	Can be changed	Scaling	Data set	Data type	Acc. Level														
P1080[0...2]	<b>Minimum frequency [Hz]</b>	0.00 - 550.00	0.00	C, U, T	-	DDS	Float	1														
	Sets minimum motor frequency at which motor will run irrespective of frequency setpoint. The minimum frequency P1080 represents a masking frequency of 0 Hz for all frequency target value sources e.g. analog input, MOP, FF, USS with the exception of the JOG target value source (analogous to P1091). Thus the frequency band + / -P1080 is run through in optimum time by means of the acceleration / deceleration ramps. Dwelling in the frequency band is not possible. Furthermore, an overshoot of the actual frequency $f_{act}$ upper minimum frequency P1080 is output by the signal function $ f_{act}  > f_{min}$ .																					
<b>Note:</b>	Value set here is valid both for clockwise and for anticlockwise rotation. Under certain conditions (e.g. ramping, current limiting), motor can run below minimum frequency.																					
P1082[0...2]	<b>Maximum frequency [Hz]</b>	0.00 - 550.00	50.00	C, T	-	DDS	Float	1														
	Sets maximum motor frequency at which motor will run irrespective of the frequency setpoint. The value set here is valid for both clockwise and anticlockwise rotation. Furthermore, the monitoring function $ f_{act}  \geq P1082$ (r0052 bit 10, see example below) is affected by this parameter.																					
<b>Example:</b>	<p>The graph shows the actual frequency <math> f_{act} </math> (top curve) and the state of Bit 10 of r0052 (bottom curve) over time <math>t</math>. The frequency starts at a low value, ramps up to reach the P1082 limit, remains constant at that level for a short duration, then ramps down. Bit 10 is set to 1 (high) during the period where the actual frequency is above the P1082 limit. A horizontal dashed line indicates the P1082 - 3 Hz level.</p>																					
<b>Dependency:</b>	<p>The maximum value of P1082 also depends on the nominal frequency: Max. P1082 = min (15*P0310, 550.0 Hz). As consequence P1082 can be affected if P0310 is changed to a smaller value. The maximum frequency and the pulse frequency depending on each other. The maximum frequency affects the pulse frequency according to the following table.</p> <table border="1" style="width: 100%; text-align: center;"> <thead> <tr> <th rowspan="2"></th> <th colspan="4">P1800</th> </tr> <tr> <th>2 kHz</th> <th>4 kHz</th> <th>6 kHz</th> <th>8 - 16 kHz</th> </tr> </thead> <tbody> <tr> <td><math>f_{max} P1082</math></td> <td>0 - 133.3 Hz</td> <td>0 - 266.6 Hz</td> <td>0 - 400 Hz</td> <td>0 - 550.0 Hz</td> </tr> </tbody> </table> <p><b>Example:</b> If P1082 is set to 350 Hz a pulse frequency from at least 6 kHz is necessary. If P1800 is smaller than 6 kHz the parameter is changed P1800 = 6 kHz. The maximum output frequency of inverter can be exceeded if one of the following is active:</p> <ul style="list-style-type: none"> <li>- P1335 <math>\neq</math> 0 (Slip compensation active):                     <math display="block">f_{max} (P1335) = f_{max} + f_{slip,max} = P1082 + \frac{P1336}{100} \cdot \frac{r0330}{100} \cdot P0310</math> </li> <li>- P1200 <math>\neq</math> 0 (Flying restart active):                     <math display="block">f_{max} (P1200) = f_{max} + 2 \cdot f_{slip,nom} = P1082 + 2 \cdot \frac{r0330}{100} \cdot P0310</math> </li> </ul>									P1800				2 kHz	4 kHz	6 kHz	8 - 16 kHz	$f_{max} P1082$	0 - 133.3 Hz	0 - 266.6 Hz	0 - 400 Hz	0 - 550.0 Hz
	P1800																					
	2 kHz	4 kHz	6 kHz	8 - 16 kHz																		
$f_{max} P1082$	0 - 133.3 Hz	0 - 266.6 Hz	0 - 400 Hz	0 - 550.0 Hz																		



Parameter	Function	Range	Factory default	Can be changed	Scaling	Data set	Data type	Acc. Level
<b>Note:</b>	When using the setpoint source <ul style="list-style-type: none"> <li>Analog Input</li> <li>USS</li> </ul> the setpoint frequency (in Hz) is cyclically calculated using <ul style="list-style-type: none"> <li>a percentage value (e.g. for the analog input r0754)</li> <li>a hexadecimal value (e.g. for the USS r2018[1])</li> <li>and the reference frequency P2000.</li> </ul> If for example P1082 = 80 Hz, P2000 = 50 Hz and the analog input is parameterized with P0757 = 0 V, P0758 = 0 %, P0759 = 10 V, P0760 = 100 %, a setpoint frequency of 50 Hz will be applied at 10 V of the analog input. When Quick Commissioning is carried out P2000 is changed as follows: P2000 = P1082.							
r1084	<b>Resultant maximum frequency [Hz]</b>	-	-	-	-	-	Float	3
	Displays resultant maximum frequency.							
P1091[0...2]	<b>Skip frequency [Hz]</b>	0.00 - 550.00	0.00	U, T	-	DDS	Float	3
	Defines skip frequency 1 which avoids effects of mechanical resonance and suppresses frequencies within + / -P1101 (skip frequency bandwidth).							
<b>Notice:</b>	Stationary operation is not possible within the suppressed frequency range; the range is merely passed through (on the ramp). For example, if P1091 = 10 Hz and P1101 = 2 Hz, it is not possible to operate continuously between 10 Hz + / - 2 Hz (i.e. between 8 and 12 Hz).							
<b>Note:</b>	The function is disabled if P1091 = 0.							
P1092[0...2]	<b>Skip frequency 2 [Hz]</b>	0.00 - 550.00	0.00	U, T	-	DDS	Float	3
	Defines skip frequency 2 which avoids effects of mechanical resonance and suppresses frequencies within + / -P1101 (skip frequency bandwidth).							
<b>Note:</b>	See P1091							
P1093[0...2]	<b>Skip frequency 3 [Hz]</b>	0.00 - 550.00	0.00	U, T	-	DDS	Float	3
	Defines skip frequency 3 which avoids effects of mechanical resonance and suppresses frequencies within + / -P1101 (skip frequency bandwidth).							
<b>Note:</b>	See P1091							
P1094[0...2]	<b>Skip frequency 4 [Hz]</b>	0.00 - 550.00	0.00	U, T	-	DDS	Float	3
	Defines skip frequency 4 which avoids effects of mechanical resonance and suppresses frequencies within + / -P1101 (skip frequency bandwidth).							
<b>Note:</b>	See P1091							
P1101[0...2]	<b>Skip frequency bandwidth [Hz]</b>	0.00 - 10.00	2.00	U, T	-	DDS	Float	3
	Delivers frequency bandwidth to be applied to skip frequencies.							
<b>Note:</b>	See P1091							
P1110[0...2]	<b>BI: Inhibit negative frequency setpoint</b>	0 - 4294967295	0	T	-	CDS	U32	3
	This parameter suppresses negative setpoints. Therefore, modification of the motor direction is inhibited to the set-point channel. If a minimum frequency (P1080) and a negative setpoint are given, the motor is accelerated by a positive value in relationship to the minimum frequency.							
<b>Setting:</b>	0	Disabled						
	1	Enabled						
P1113[0...2]	<b>BI: Reverse</b>	0 - 4294967295	19.11	T	-	CDS	U32	3
	Defines source of reverse command used when P0719 = 0 (Auto selection of command / setpoint source).							

7.2 Parameter list

Parameter	Function	Range	Factory default	Can be changed	Scaling	Data set	Data type	Acc. Level
<b>Setting:</b>	722.0	Digital input 1 (requires P0701 to be set to 99, BICO)						
	722.1	Digital input 2 (requires P0702 to be set to 99, BICO)						
	722.2	Digital input 3 (requires P0703 to be set to 99, BICO)						
r1114	<b>CO: Freq. setpoint after direction control [Hz]</b>	-	-	-	-	-	Float	3
	Displays setpoint frequency after change of direction.							
r1119	<b>CO: Freq. setpoint before RFG [Hz]</b>	-	-	-	-	-	Float	3
	Displays frequency setpoint at the input to the ramp function generator after modification by other functions, e.g.: <ul style="list-style-type: none"> <li>• P1110 BI: Inhibit neg. freq. setpoint,</li> <li>• P1091 - P1094 skip frequencies,</li> <li>• P1080 min. frequency,</li> <li>• P1082 max. frequency,</li> </ul> This value is available filtered (r0020) and unfiltered (r1119).							
P1120[0...2]	<b>Ramp-up time [s]</b>	0.00 - 650.00	10.00	C, U, T	-	DDS	Float	1
	Time taken for motor to accelerate from standstill up to maximum motor frequency (P1082) when no rounding is used. Setting the ramp-up time too short can cause the inverter to trip (overcurrent F1).							
<b>Dependency:</b>	Rounding times (P1130 - P1133) and rounding type (P1134) will also have influence on the ramp. See also P3350, P3353.							
<b>Notice:</b>	Ramp times will be used as follows: <ul style="list-style-type: none"> <li>• P1060 / P1061 : JOG mode is active</li> <li>• P1120 / P1121 : Normal mode (ON / OFF) is active</li> <li>• P1060 / P1061 : Normal mode (ON / OFF) and P1124 is active</li> </ul>							
<b>Note:</b>	If an external frequency setpoint with set ramp rates is used (e.g. from a PLC), the best way to achieve optimum inverter performance is to set ramp times in P1120 and P1121 slightly shorter than those of the PLC. Changes to P1120 will be immediately effective. If the SuperTorque function is enabled, the inverter will initially ramp using the value in P3353.							
P1121[0...2]	<b>Ramp-down time [s]</b>	0.00 - 650.00	10.00	C, U, T	-	DDS	Float	1
	Time taken for motor to decelerate from maximum motor frequency (P1082) down to standstill when no rounding is used.							
<b>Dependency:</b>	See also P3350, P3353.							
<b>Notice:</b>	Setting the ramp-down time too short can cause the inverter to trip (overcurrent F1 / overvoltage F2). See P1120							
<b>Note:</b>	Changes to P1121 will be immediately effective. See P1120							
P1124[0...2]	<b>BI: Enable JOG ramp times</b>	0 - 4294967295	0	T	-	CDS	U32	3
	Defines source for switching between jog ramp times (P1060, P1061) and normal ramp times (P1120, P1121) as applied to the RFG. This parameter is valid for normal mode (ON / OFF) only.							
<b>Dependency:</b>	See also P1175.							
<b>Notice:</b>	P1124 does not have any impact when JOG mode is selected. In this case, jog ramp times (P1060, P1061) will be used all the time. If the Dual Ramp function is selected using P1175, ramp times will switch between normal (P1120, P1121) and JOG (P1060, P1061) ramp times, depending on the settings of P2150, P2157 and P2159. Therefore, it is not recommended that JOG ramp is selected at the same time as Dual Ramp. See P1120.							

Parameter	Function	Range	Factory default	Can be changed	Scaling	Data set	Data type	Acc. Level
P1130[0...2]	<b>Ramp-up initial rounding time [s]</b>	0.00 - 40.00	0.00	U, T	-	DDS	Float	2
	Defines rounding time in seconds at start of ramp-up.							
<b>Notice:</b>	Rounding times are recommended, since they prevent an abrupt response, thus avoiding detrimental effects on the mechanics. Rounding times are not recommended when analog inputs are used, since they would result in overshoot / undershoot in the inverter response.							
<b>Note:</b>	If short or zero ramp times (P1120, P1121 < P1130, P1131, P1132, P1133) are set, the total ramp up time (t <sub>up</sub> ) or ramp down time (t <sub>down</sub> ) will not depend on P1130.							
P1131[0...2]	<b>Ramp-up final rounding time [s]</b>	0.00 - 40.00	0.00	U, T	-	DDS	Float	2
	Defines rounding time at end of ramp-up.							
<b>Notice:</b>	See P1130							
P1132[0...2]	<b>Ramp-down initial rounding time [s]</b>	0.00 - 40.00	0.00	U, T	-	DDS	Float	2
	Defines rounding time at start of ramp-down.							
<b>Notice:</b>	See P1130							
P1133[0...2]	<b>Ramp-down final rounding time [s]</b>	0.00 - 40.00	0.00	U, T	-	DDS	Float	2
	Defines rounding time at end of ramp-down.							
<b>Notice:</b>	See P1130							
P1134[0...2]	<b>Rounding type</b>	0 - 1	0	U, T	-	DDS	U16	2
	Defines the smoothing which is active by setpoint modifications during acceleration or deceleration (e.g. new setpoint, OFF1, OFF3, REV). This smoothing is applied, if the motor is ramped-up or ramped-down and							
	<ul style="list-style-type: none"> <li>• P1134 = 0,</li> <li>• P1132 &gt; 0, P1133 &gt; 0 and</li> <li>• the setpoint is not yet reached.</li> </ul>							
	0	Continuous smoothing						
	1	Discontinuous smoothing						
<b>Dependency:</b>	Effect only when P1130 (Ramp-up initial rounding time) or P1131 (Ramp-up final rounding time) or P1132 (Ramp-down initial rounding time) or P1133 (Ramp-down final rounding time) > 0 s.							
P1135[0...2]	<b>OFF3 ramp-down time [s]</b>	0.00 - 650.00	5.00	C, U, T	-	DDS	Float	2
	Defines ramp-down time from maximum frequency to standstill for OFF3 command. Settings in P1130 and P1134 will have no effect on OFF3 ramp-down characteristic. An initial ramp-down rounding time of approximately 10% of P1135 is however included. For the total OFF3 ramp-down time: t <sub>down,OFF3</sub> = f(P1134) = 1.1 * P1135 * ( f <sub>2</sub>   / P1082)							
<b>Note:</b>	This time may be exceeded if the V <sub>dc_max</sub> level is reached.							
P1140[0...2]	<b>BI: RFG enable</b>	0 - 4294967295	1	T	-	CDS	U32	3
	Defines command source of RFG enable command (RFG: ramp function generator). If binary input is equal to zero then the RFG output will be set immediately to 0.							
P1141[0...2]	<b>BI: RFG start</b>	0 - 4294967295	1	T	-	CDS	U32	3
	Defines command source of RFG start command (RFG: ramp function generator). If binary input is equal to zero then the RFG output is held at its present value.							
P1142[0...2]	<b>BI: RFG enable setpoint</b>	0 - 4294967295	1	T	-	CDS	U32	3

Parameter	Function	Range	Factory default	Can be changed	Scaling	Data set	Data type	Acc. Level
	Defines command source of RFG enable setpoint command (RFG: ramp function generator). If binary input is equal to zero, the RFG input will be set to zero and the RFG output will ramp-down to zero.							
r1170	<b>CO: Frequency setpoint after RFG [Hz]</b>	-	-	-	-	-	Float	3
	Displays overall frequency setpoint after ramp generator.							
P1175[0...2]	<b>BI: Dual ramp enable</b>	0 - 4294967295	0	T	-	CDS	U32	3
	<p>Defines command source of dual ramp enable command. If binary input is equal to one, then the dual ramp will be applied. This works as follows:</p> <ul style="list-style-type: none"> <li>• Ramp-up:                             <ul style="list-style-type: none"> <li>– Inverter starts ramp-up using ramp time from P1120</li> <li>– When <math>f_{act} &gt; P2157</math>, switch to ramp time from P1060</li> </ul> </li> <li>• Ramp-down:                             <ul style="list-style-type: none"> <li>– Inverter starts ramp-down using ramp time from P1061</li> <li>– When <math>f_{act} &lt; P2159</math>, switch to ramp time from P1121</li> </ul> </li> </ul>							
<b>Dependency:</b>	See P2150, P2157, P2159, r2198.							
<b>Note:</b>	The dual ramp algorithm uses r2198 bits 1 and 2 to determine ( $f_{act} > P2157$ ) and ( $f_{act} < P2159$ ). P2150 is used to apply hysteresis to these settings, so the user may wish to change the value of this parameter to make the dual ramp function more responsive. It is not recommended that the dual ramp function is used in conjunction with JOG ramp. See P1124.							
r1199.7...12	<b>CO / BO: RFG status word</b>	-	-	-	-	-	U16	3
	Displays status of ramp function generator (RFG).							
	<b>Bit</b>	<b>Signal name</b>			<b>1 signal</b>		<b>0 signal</b>	
	07	Ramp #0 active			Yes		No	

Parameter	Function	Range	Factory default	Can be changed	Scaling	Data set	Data type	Acc. Level
	08	Ramp #1 active			Yes		No	
	09	Ramping finished			Yes		No	
	10	Direction right / left			Yes		No	
	11	f_act > P2157(f_2)			Yes		No	
	12	f_act < P2159(f_3)			Yes		No	
<b>Note:</b>	See P2157 and P2159.							
P1200	<b>Flying start</b>	0 - 6	0	U, T	-	-	U16	2
	Starts inverter onto a spinning motor by rapidly changing the output frequency of the inverter until the actual motor speed has been found. Then, the motor runs up to setpoint using the normal ramp time.							
	0	Flying start disabled						
	1	Flying start always active; searches in both directions						
	2	Flying start active after power on, fault, OFF2; searches in both directions						
	3	Flying start active after fault, OFF2; searches in both directions						
	4	Flying start always active; searches in direction of setpoint only						
	5	Flying start active after power on, fault, OFF2; searches in direction of setpoint only						
	6	Flying start active after fault, OFF2; searches in direction of setpoint only						
<b>Notice:</b>	Flying start must be used in cases where the motor may still be turning (e.g. after a short mains break) or can be driven by the load. Otherwise, overcurrent trips will occur.							
<b>Note:</b>	Useful for motors with high inertia loads. Settings 1 to 3 search in both directions. Settings 4 to 6 search only in direction of setpoint.							
P1202[0...2]	<b>Motor-current: flying start [%]</b>	10 - 200	100	U, T	-	DDS	U16	3
	Defines search current used for flying start. Value is in [%] based on rated motor current (P0305).							
<b>Note:</b>	Reducing the search current may improve performance for flying start if the inertia of the system is not very high. However, search current settings in P1202 that are below 30% (and sometimes other settings in P1202 and P1203) may cause motor speed to be found prematurely or too late, which can result in F1 or F2 trips.							
P1203[0...2]	<b>Search rate: flying start [%]</b>	10 - 500	100	U, T	-	DDS	U16	3
	Sets factor (in V/f mode only) by which the output frequency changes during flying start to synchronize with turning motor. This value is entered in [%]. It defines the reciprocal initial gradient in the search sequence. P1203 influences the time taken to search for the motor frequency.							
<b>Example:</b>	For a motor with 50 Hz, 1350 rpm, 100 % would produce a maximum search time of 600 ms.							
<b>Note:</b>	A higher value produces a flatter gradient and thus a longer search time. A lower value has the opposite effect.							
r1204	<b>Status word: flying start V/f</b>	-	-	-	-	-	U16	4
	Bit parameter for checking and monitoring states during search.							
	<b>Bit</b>	<b>Signal name</b>			<b>1 signal</b>		<b>0 signal</b>	
	00	Current applied			Yes		No	
	01	Current could not be applied			Yes		No	
	02	Voltage reduced			Yes		No	
	03	Slope-filter started			Yes		No	
	04	Current less threshold			Yes		No	
	05	Current-minimum			Yes		No	
	07	Speed could not be found			Yes		No	

7.2 Parameter list

Parameter	Function	Range	Factory default	Can be changed	Scaling	Data set	Data type	Acc. Level
P1210	<b>Automatic restart</b>	0 - 7	1	U, T	-	-	U16	2
	Configures automatic restart function.							
	0	Disabled						
	1	Trip reset after power on, P1211 disabled						
	2	Restart after mains blackout, P1211 disabled						
	3	Restart after mains brownout or fault, P1211 enabled						
	4	Restart after mains brownout, P1211 enabled						
	5	Restart after mains blackout and fault, P1211 disabled						
	6	Restart after mains brown- /blackout or fault, P1211 enabled						
	7	Restart after mains brown- /blackout or fault, trip when P1211 expires						
<b>Dependency:</b>	Automatic restart requires constant ON command via a digital input wire link.							
<b>Caution:</b>	P1210 > 2 can cause the motor to restart automatically without toggling the ON command!							
<b>Notice:</b>	<p>A "mains brownout" is a very short mains break, where the DC link has not fully collapsed before the power is reapplied.</p> <p>A "mains blackout" is a long mains break, where the DC link has fully collapsed before the power is re-applied.</p> <p>"Delay Time" is the time between attempts of quitting fault. The "Delay Time" of first attempt is 1 second, then it will be doubled every next attempt.</p> <p>The "Number of Restart Attempts" can be set in P1211. This is the number of restarts the inverter will try to quit fault.</p> <p>When faults are quit and after 4 seconds of no fault condition, "Number of Restart Attempts" will be reset to P1211 and "Delay Time" will be reset to 1 second.</p> <p>P1210 = 0: Automatic restart is disabled.</p> <p>P1210 = 1: The inverter will acknowledge (reset) faults i.e. it will reset a fault when the power is re-applied. This means the inverter must be fully powered down, a brownout is not sufficed. The inverter will not run until the ON command has been toggled.</p> <p>P1210 = 2: The inverter will acknowledge the fault F3 at power on after blackout and restarts the inverter. It is necessary that the ON command is wired via a digital input (digital input).</p> <p>P1210 = 3: For these settings it is fundamental that the inverter only restarts if it has been in a RUN state at the time of the faults (F3, etc.). The inverter will acknowledge the fault and restarts the inverter after a brownout. It is necessary that the ON command is wired via a digital input (digital input).</p> <p>P1210 = 4: For these settings it is fundamental that the inverter only restarts if it has been in a RUN state at the time of the fault (F3). The inverter will acknowledge the fault and restarts the inverter after a brownout. It is necessary that the ON command is wired via a digital input (digital input).</p> <p>P1210 = 5: The inverter will acknowledge the faults F3 etc. at power on after blackout and restarts the inverter. It is necessary that the ON command is wired via a digital input (digital input).</p>							

Parameter	Function	Range	Factory default	Can be changed	Scaling	Data set	Data type	Acc. Level
	<p>P1210 = 6: The inverter will acknowledge the faults (F3 etc.) at power on after blackout or brownout and restarts the inverter. It is necessary that the ON command is wired via a digital input (digital input). Setting 6 causes the motor to restart immediately.</p> <p>P1210 = 7: The inverter will acknowledge the faults (F3 etc.) at power on after blackout or brownout and restarts the inverter. It is necessary that the ON command is wired via a digital input (digital input). Setting 7 causes the motor to restart immediately.</p> <p>The difference between this mode and Mode 6 is that the fault status bit (r0052.3) is not set until the number of restarts defined by P1211 have been exhausted.</p> <p>Flying start must be used in cases where the motor may still be turning (e.g. after a short mains break) or can be driven by the load (P1200).</p>							
P1211	<b>Number of restart attempts</b>	0 - 10	3	U, T	-	-	U16	3
	Specifies number of times inverter will attempt to restart if automatic restart P1210 is activated.							
P1215	<b>Holding brake enable</b>	0 - 1	0	C, T	-	-	U16	2
	<p>Enables / disables holding brake function. The motor holding brake (MHB) is controlled via status word 1 r0052 bit 12. This signal can be issued via:</p> <ul style="list-style-type: none"> <li>status word of the serial interface (e.g. USS)</li> <li>digital outputs (e.g. DO1: ==&gt; P0731 = 52.C (r0052 bit 12))</li> </ul>							
	0	Motor holding brake disabled						
	1	Motor holding brake enabled						
<b>Caution:</b>	<p>If the inverter controls the motor holding brake, then a commissioning may not be carried out for potentially hazardous loads (e.g. suspended loads for crane applications) unless the load has been secured.</p> <p>It is not permissible to use the motor holding brake as working brake, as it is generally only designed for a limited number of emergency braking operations.</p>							
P1216	<b>Holding brake release delay[s]</b>	0.0 - 20.0	1.0	C, T	-	-	Float	2
	Defines period during which inverter runs at minimum frequency P1080 before ramping up.							
P1217	<b>Holding time after ramp down [s]</b>	0.0 - 20.0	1.0	C, T	-	-	Float	2
	Defines time for which inverter runs at minimum frequency (P1080) after ramping down.							
<b>Note:</b>	If P1217 > P1227, P1227 will take precedence.							
P1218[0...2]	<b>BI: Motor holding brake override</b>	0 - 4294967295	0	U, T	-	CDS	U32	3
	Enables the motor holding brake output to be overridden, allowing the brake to be opened under separate control.							
P1227[0...2]	<b>Zero speed detection monitoring time [s]</b>	0.0 - 300.0	4.0	U, T	-	DDS	Float	2
	<p>Sets the monitoring time for the standstill identification.</p> <p>When braking with OFF1 or OFF3, standstill is identified after this time has expired, after the setpoint speed has fallen below P2167. After this, the braking signal is started, the system waits for the closing time and then the pulses are cancelled.</p>							

7.2 Parameter list

Parameter	Function	Range	Factory default	Can be changed	Scaling	Data set	Data type	Acc. Level
<b>Note:</b>	P1227 = 300.0: function is deactivated P1227 = 0.0: pulses are locked immediately If P1217 > P1227, P1227 will take precedence.							
P1230[0...2]	<b>BI: Enable DC braking</b>	0 - 429496729 5	0	U, T	-	CDS	U32	3
	Enables DC braking via a signal applied from an external source. Function remains active while external input signal is active. DC braking causes the motor to stop rapidly by applying a DC braking current (current applied also holds shaft stationary).  When the DC braking signal is applied, the inverter output pulses are blocked and the DC current is not applied until the motor has been sufficiently demagnetized. This delay time is set in P0347 (demagnetization time). If this delay is too short, overcurrent trips can occur. The level of DC braking is set in P1232 (DC braking current - relative to the rated motor current) which is set to 100 % by default.							
<b>Caution:</b>	With the DC braking, the kinetic energy of the motor is converted into heat in the motor. The inverter could overheat if it remains in this status for an excessive period of time!							
P1232[0...2]	<b>DC braking current [%]</b>	0 - 250	100	U, T	-	DDS	U16	2
	Defines level of DC current relative to rated motor current (P0305). The DC braking can be issued observing the following dependencies: <ul style="list-style-type: none"> <li>• OFF1 / OFF3 ==&gt; see P1233</li> <li>• BICO ==&gt; see P1230</li> </ul>							
P1233[0...2]	<b>Duration of DC braking [s]</b>	0.00 - 250.00	0.00	U, T	-	DDS	Float	2
	Defines duration for which DC braking is active following an OFF1 or OFF3 command. When an OFF1 or OFF3 command is received by the inverter, the output frequency starts to ramp to 0 Hz. When the output frequency reaches the value set in P1234, the inverter injects a DC braking current P1232 for the time duration set in P1233.							
<b>Caution:</b>	See P1230							
<b>Notice:</b>	The DC braking function causes the motor to stop rapidly by applying a DC braking current. When the DC braking signal is applied, the inverter output pulses are blocked and the DC current not applied until the motor has been sufficiently demagnetized (demagnetization time is calculated automatically from motor data).							
<b>Note:</b>	P1233 = 0 means that DC braking is not activated.							
P1234[0...2]	<b>DC braking start frequency [Hz]</b>	0.00 - 550.00	550.00	U, T	-	DDS	Float	2
	Sets start frequency for DC braking. When an OFF1 or OFF3 command is received by the inverter, the output frequency starts to ramp to 0 Hz. When the output frequency reaches the value set in start frequency of DC braking P1234, the inverter injects a DC braking current P1232 for the time duration set in P1233.							
P1236[0...2]	<b>Compound braking current [%]</b>	0 - 250	0	U, T	-	DDS	U16	2



Parameter	Function	Range	Factory default	Can be changed	Scaling	Data set	Data type	Acc. Level
	<p>Defines DC level superimposed on AC waveform after exceeding DC-link voltage threshold of compound braking. The value is entered in [%] relative to rated motor current (P0305). Compound braking switch-on level (V_DC,Comp):</p> <p>If P1254 = 0 --&gt; <math>V_{DC,Comp} = 1.13 * \sqrt{2} * V_{mains} = 1.13 * \sqrt{2} * P0210</math>  otherwise <math>V_{DC,Comp} = 0.98 * r1242</math></p> <p>The Compound Brake is an overlay of the DC brake function with regenerative braking (effective braking at the ramp) after OFF1 or OFF3. This enables braking with controlled motor frequency and a minimum of energy returned to the motor. Through optimization of the ramp-down time and the compound braking an efficient braking without additional HW components is possible.</p>							
<b>Dependency:</b>	<p>Compound braking depends on the DC link voltage only (see threshold above). This will happen on OFF1, OFF3 and any regenerative condition. It is disabled, when:</p> <ul style="list-style-type: none"> <li>• DC braking is active</li> <li>• Flying start is active</li> </ul>							
<b>Notice:</b>	<p>Increasing the value will generally improve braking performance; however, if you set the value too high, an overcurrent trip may result.</p> <p>If used with dynamic braking enabled as well compound braking will take priority.</p> <p>If used with the Vdc_max controller enabled the inverter behavior when braking may be worsened particularly with high values of compound braking.</p>							
<b>Note:</b>	P1236 = 0 means that compound braking is not activated.							
P1237	<b>Dynamic braking</b>	0 - 5	0	U, T	-	-	U16	2
	<p>Dynamic braking absorbs the braking energy in a chopper resistor.</p> <p>This parameter defines the rated duty cycle of the braking resistor (chopper resistor).</p> <p>Dynamic braking is active when the function is enabled and DC-link voltage exceeds the dynamic braking switch-on level.</p> <p>Dynamic braking switch-on level (V_DC,Chopper) :</p> <p>If P1254 = 0 --&gt; <math>V_{DC,Chopper} = 1.13 * \sqrt{2} * V_{mains} = 1.13 * \sqrt{2} * P0210</math>  otherwise <math>V_{DC,Chopper} = 0.98 * r1242</math></p>							
	0	Disabled						
	1	5 % duty cycle						
	2	10 % duty cycle						
	3	20 % duty cycle						
	4	50 % duty cycle						
	5	100 % duty cycle						
<b>Note:</b>	<p>This parameter is only applicable for inverters of frame size D. For frame sizes A to C, the duty cycle of the braking resistor can be selected with the dynamic braking module (see Appendix "Dynamic braking module (Page 312)").</p>							

Parameter	Function	Range	Factory default	Can be changed	Scaling	Data set	Data type	Acc. Level
<b>Dependency:</b>	<p>If dynamic braking is used with DC braking enabled as well as compound braking, DC braking and compound braking will take priority.</p> <pre> graph TD     Start(( )) --&gt; D1{DC braking P1233 &gt; 0 ?}     D1 -- yes --&gt; DC[DC braking enabled]     D1 -- no --&gt; D2{Compound braking P1236 &gt; 0 ?}     D2 -- yes --&gt; CB[Compound braking enabled]     D2 -- no --&gt; D3{Dynamic braking P1237 &gt; 0 ?}     D3 -- yes --&gt; DB[Dynamic braking enabled]     D3 -- no --&gt; Disabled[Disabled]     </pre>							
<b>Notice:</b>	<p>Initially the brake will operate at a high duty cycle dependant on the DC link level until the thermal limit is approached. The duty cycle specified by this parameter will then be imposed. The resistor should be able to operate at this level indefinitely without overheating.</p> $t_{\text{Chopper, ON}} = \frac{x}{100} \cdot t_{\text{Chopper}}$ $\Delta V = 17.0 \text{ V for } 380 - 480 \text{ V}$ <p>The threshold for the warning A535 is equivalent to 10 seconds running at 95 % duty cycle. The duty cycle will be limited when it was running 12 seconds at 95 % duty cycle.</p>							
P1240[0...2]	<b>Configuration of Vdc controller</b>	0 - 3	1	C, T	-	DDS	U16	3
	Enables / disables Vdc controller. The Vdc controller dynamically controls the DC link voltage to prevent overvoltage trips on high inertia systems.							
	0	Vdc controller disabled						
	1	Vdc_max controller enabled						
	2	Kinetic buffering (Vdc_min controller) enabled						
	3	Vdc_max controller and kinetic buffering (KIB) enabled						
<b>Caution:</b>	If P1245 increased too much, it may interfere with the inverter normal operation.							
<b>Note:</b>	<ul style="list-style-type: none"> <li>Vdc_max controller: Vdc_max controller automatically increases ramp-down times to keep the DC-link voltage (r0026) within limits (r1242).</li> <li>Vdc_min controller: Vdc_min is activated if DC-link voltage falls below the switch on level P1245. The kinetic energy of the motor is then used to buffer the DC-link voltage, thus causing deceleration of the inverter. If the inverter trips with F3 immediately, try increasing the dynamic factor P1247 first. If still tripping with F3 try then increasing the switch on level P1245.</li> </ul>							
r1242	<b>CO: Switch-on level of Vdc_max [V]</b>	-	-	-	-	-	Float	3

Parameter	Function	Range	Factory default	Can be changed	Scaling	Data set	Data type	Acc. Level
	Displays switch-on level of Vdc_max controller. Following equation is only valid, if P1254 = 0: $r1242 = 1.15 * \sqrt{2} * V\_mains = 1.15 * \sqrt{2} * P0210$ otherwise r1242 is internally calculated.							
P1243[0...2]	<b>Dynamic factor of Vdc_max [%]</b>	10 - 200	100	U, T	-	DDS	U16	3
	Defines dynamic factor for DC link controller.							
<b>Dependency:</b>	P1243 = 100 % means P1250, P1251 and P1252 (gain, integration time and differential time) are used as set. Otherwise, these are multiplied by P1243 (dynamic factor of Vdc_max).							
<b>Note:</b>	Vdc controller adjustment is calculated automatically from motor and inverter data.							
P1245[0...2]	<b>Switch on level kinetic buffering [%]</b>	65 - 95	76	U, T	-	DDS	U16	3
	Enter switch-on level for kinetic buffering (KIB) in [%] relative to supply voltage (P0210). $r1246[V] = (P1245[\%] / 100) * \sqrt{2} * P0210$							
<b>Warning:</b>	Increasing the value too much, may interfere with the inverter normal operation.							
<b>Note:</b>	P1254 has no effect on the switch-on-level for kinetic buffering. P1245 default for the single phase variants is 74%.							
r1246[0...2]	<b>CO: Switch-on level kinetic buffering [V]</b>	-	-	-	-	DDS	Float	3
	Displays switch-on level of kinetic buffering (KIB, Vdc_min controller). If the dc-link voltage drops below the value in r1246, kinetic buffering will be activated. That means the motor frequency will be reduced in order to keep Vdc within the valid range. If there is not enough regenerative energy, the inverter trips with undervoltage.							
P1247[0...2]	<b>Dynamic factor of kinetic buffering [%]</b>	10 - 200	100	U, T	-	DDS	U16	3
	Enters dynamic factor for kinetic buffering (KIB, Vdc_min controller). P1247 = 100 % means P1250, P1251 and P1252 (gain, integration time and differential time) are used as set. Otherwise, these are multiplied by P1247 (dynamic factor of Vdc_min).							
<b>Note:</b>	Vdc controller adjustment is calculated automatically from motor and inverter data.							
P1250[0...2]	<b>Gain of Vdc controller</b>	0.00 - 10.00	1.00	U, T	-	DDS	Float	3
	Enters gain for Vdc controller.							
P1251[0...2]	<b>Integration time Vdc controller [ms]</b>	0.1 - 1000.0	40.0	U, T	-	DDS	Float	3
	Enters integral time constant for Vdc controller.							
P1252[0...2]	<b>Differential time Vdc controller [ms]</b>	0.0 - 1000.0	1.0	U, T	-	DDS	Float	3
	Enters differential time constant for Vdc controller.							
P1253[0...2]	<b>Vdc controller output limitation [Hz]</b>	0.00 - 550.00	10.00	U, T	-	DDS	Float	3
	Limits maximum effect of Vdc_max controller.							
<b>Dependency:</b>	This parameter is influenced by automatic calculations defined by P0340.							
<b>Note:</b>	The Factory setting depends on inverter power.							
P1254	<b>Auto detect Vdc switch-on levels</b>	0 - 1	1	C, T	-	-	U16	3
	Enables / disables auto-detection of switch-on levels for Vdc_max controller. For best results, it is recommended to set P1254 = 1 (auto-detection of Vdc switch-on levels enabled). Setting P1254 = 0 is only recommended when there is a high degree of fluctuation of the DC-link when the motor is being driven. Note that the auto detection only works when the inverter has been in standby for over 20s.							
	0	Disabled						
	1	Enabled						

7.2 Parameter list

Parameter	Function	Range	Factory default	Can be changed	Scaling	Data set	Data type	Acc. Level
<b>Dependency:</b>	See P0210							
P1256[0...2]	<b>Reaction of kinetic buffering</b>	0 - 2	0	C, T	-	DDS	U16	3
	Enters reaction for kinetic buffering controller (Vdc_min controller). Depending on the setting selected, the frequency limit defined in P1257 is used to either hold the speed or disable pulses. If not enough regeneration is produced, inverter may trip with undervoltage.							
	0	Maintain DC-link until trip						
	1	Maintain DC-link until trip / stop						
	2	Control stop						
<b>Note:</b>	<p>P1256 = 0: Maintain DC-link voltage until mains is returned or inverter is tripped with undervoltage. The frequency is kept above the frequency limit provided in P1257.</p> <p>P1256 = 1: Maintain DC-link voltage until mains is returned or inverter is tripped with undervoltage or pulses are disabled when frequency falls below the limit in P1257.</p> <p>P1256 = 2: This option ramps down the frequency to standstill even when mains return. If mains do not return, frequency brought down under the control of Vdc_min controller until P1257 limit. Then pulses are disabled or undervoltage has occurred. If mains return, then an OFF1 is active until P1257 limit. Then pulses are disabled.</p>							
P1257[0...2]	<b>Frequency limit for kinetic buffering [Hz]</b>	0.00 - 550.00	2.50	U, T	-	DDS	Float	3
	Frequency which kinetic buffering (KIB) either hold speed or disable pulses depending on P1256.							
P1300[0...2]	<b>Control mode</b>	0 - 19	0	C, T	-	DDS	U16	2
	Parameter to select the control method. Controls relationship between speed of motor and voltage supplied by inverter.							
	0	V/f with linear characteristic						
	1	V/f with FCC						
	2	V/f with quadratic characteristic						
	3	V/f with programmable characteristic						
	4	V/f with linear eco						
	5	V/f for textile applications						
	6	V/f with FCC for textile applications						
	7	V/f with quadratic eco						
	19	V/f control with independent voltage setpoint						
	<p>The graph plots voltage (V) on the vertical axis against frequency (f) on the horizontal axis. The maximum voltage is labeled V<sub>n</sub> and the maximum frequency is labeled f<sub>n</sub>. Two curves are shown: a straight line from the origin to (f<sub>n</sub>, V<sub>n</sub>) labeled 'P1300 = 0', and a curve that starts at the origin and follows a parabolic path below the linear line, also ending at (f<sub>n</sub>, V<sub>n</sub>) labeled 'P1300 = 2'.</p>							

Parameter	Function	Range	Factory default	Can be changed	Scaling	Data set	Data type	Acc. Level																																																																																																																																																																																																																																													
<b>Note:</b>	<p>P1300 = 1: V/f with FCC (flux current control)</p> <ul style="list-style-type: none"> <li>Maintains motor flux current for improved efficiency</li> <li>If FCC is chosen, linear V/f is active at low frequencies</li> </ul> <p>P1300 = 2: V/f with a quadratic characteristic</p> <ul style="list-style-type: none"> <li>Suitable for centrifugal fans / pumps</li> </ul> <p>P1300 = 3: V/f with a programmable characteristic</p> <ul style="list-style-type: none"> <li>User defined characteristic (see P1320)</li> </ul> <p>P1300 = 4: V/f with linear characteristic and Economy Mode</p> <ul style="list-style-type: none"> <li>Linear characteristic with Economy Mode</li> <li>Modifies the output voltage to reduce power consumption</li> </ul> <p>P1300 = 5,6: V/f for textile applications</p> <ul style="list-style-type: none"> <li>Slip compensation disabled.</li> <li>Imax controller modifies the output voltage only.</li> <li>Imax controller does not influence the output frequency.</li> </ul> <p>P1300 = 7: V/f with quadratic characteristic and Economy Mode</p> <ul style="list-style-type: none"> <li>Quadratic characteristic with Economy Mode</li> <li>Modifies the output voltage to reduce power consumption</li> </ul> <p>P1300 = 19: V/f control with independent voltage setpoint</p> <p>The following table presents an overview of control parameters (V/f) that can be modified in relationship to P1300 dependencies:</p> <table border="1"> <thead> <tr> <th rowspan="2">Par No.</th> <th rowspan="2">Parameter name</th> <th rowspan="2">Level</th> <th colspan="7">V/f</th> </tr> <tr> <th colspan="7">P1300 =</th> </tr> <tr> <th></th> <th></th> <th></th> <th>0</th> <th>1</th> <th>2</th> <th>3</th> <th>5</th> <th>6</th> <th>19</th> </tr> </thead> <tbody> <tr> <td>P1300[3]</td> <td>Control mode</td> <td>2</td> <td>x</td> <td>x</td> <td>x</td> <td>x</td> <td>x</td> <td>x</td> <td>x</td> </tr> <tr> <td>P1310[3]</td> <td>Continuous boost</td> <td>2</td> <td>x</td> <td>x</td> <td>x</td> <td>x</td> <td>x</td> <td>x</td> <td>x</td> </tr> <tr> <td>P1311[3]</td> <td>Acceleration boost</td> <td>2</td> <td>x</td> <td>x</td> <td>x</td> <td>x</td> <td>x</td> <td>x</td> <td>x</td> </tr> <tr> <td>P1312[3]</td> <td>Starting boost</td> <td>2</td> <td>x</td> <td>x</td> <td>x</td> <td>x</td> <td>x</td> <td>x</td> <td>x</td> </tr> <tr> <td>P1316[3]</td> <td>Boost end frequency</td> <td>3</td> <td>x</td> <td>x</td> <td>x</td> <td>x</td> <td>x</td> <td>x</td> <td>x</td> </tr> <tr> <td>P1320[3]</td> <td>Programmable V/f freq. coord. 1</td> <td>3</td> <td>-</td> <td>-</td> <td>-</td> <td>x</td> <td>-</td> <td>-</td> <td>-</td> </tr> <tr> <td>P1321[3]</td> <td>Programmable V/f volt. coord. 1</td> <td>3</td> <td>-</td> <td>-</td> <td>-</td> <td>x</td> <td>-</td> <td>-</td> <td>-</td> </tr> <tr> <td>P1322[3]</td> <td>Programmable V/f freq. coord. 2</td> <td>3</td> <td>-</td> <td>-</td> <td>-</td> <td>x</td> <td>-</td> <td>-</td> <td>-</td> </tr> <tr> <td>P1323[3]</td> <td>Programmable V/f volt. coord. 2</td> <td>3</td> <td>-</td> <td>-</td> <td>-</td> <td>x</td> <td>-</td> <td>-</td> <td>-</td> </tr> <tr> <td>P1324[3]</td> <td>Programmable V/f freq. coord. 3</td> <td>3</td> <td>-</td> <td>-</td> <td>-</td> <td>x</td> <td>-</td> <td>-</td> <td>-</td> </tr> <tr> <td>P1325[3]</td> <td>Programmable V/f volt. coord. 3</td> <td>3</td> <td>-</td> <td>-</td> <td>-</td> <td>x</td> <td>-</td> <td>-</td> <td>-</td> </tr> <tr> <td>P1330[3]</td> <td>CI: Voltage setpoint</td> <td>3</td> <td>-</td> <td>-</td> <td>-</td> <td>-</td> <td>-</td> <td>-</td> <td>x</td> </tr> <tr> <td>P1333[3]</td> <td>Start frequency for FCC</td> <td>3</td> <td>-</td> <td>x</td> <td>-</td> <td>-</td> <td>-</td> <td>x</td> <td>-</td> </tr> <tr> <td>P1335[3]</td> <td>Slip compensation</td> <td>2</td> <td>x</td> <td>x</td> <td>x</td> <td>x</td> <td>-</td> <td>-</td> <td>-</td> </tr> <tr> <td>P1336[3]</td> <td>CO: Slip limit</td> <td>2</td> <td>x</td> <td>x</td> <td>x</td> <td>x</td> <td>-</td> <td>-</td> <td>-</td> </tr> <tr> <td>P1338[3]</td> <td>Resonance damping gain V/f</td> <td>3</td> <td>x</td> <td>x</td> <td>x</td> <td>x</td> <td>-</td> <td>-</td> <td>-</td> </tr> <tr> <td>P1340[3]</td> <td>Imax freq. controller prop. gain</td> <td>3</td> <td>x</td> <td>x</td> <td>x</td> <td>x</td> <td>x</td> <td>x</td> <td>x</td> </tr> <tr> <td>P1341[3]</td> <td>Imax controller integral time</td> <td>3</td> <td>x</td> <td>x</td> <td>x</td> <td>x</td> <td>x</td> <td>x</td> <td>x</td> </tr> <tr> <td>P1345[3]</td> <td>Imax controller prop. gain</td> <td>3</td> <td>x</td> <td>x</td> <td>x</td> <td>x</td> <td>x</td> <td>x</td> <td>x</td> </tr> <tr> <td>P1346[3]</td> <td>Imax voltage ctrl. integral time</td> <td>3</td> <td>x</td> <td>x</td> <td>x</td> <td>x</td> <td>x</td> <td>x</td> <td>x</td> </tr> <tr> <td>P1350[3]</td> <td>Voltage soft start</td> <td>3</td> <td>x</td> <td>x</td> <td>x</td> <td>x</td> <td>x</td> <td>x</td> <td>x</td> </tr> </tbody> </table>								Par No.	Parameter name	Level	V/f							P1300 =										0	1	2	3	5	6	19	P1300[3]	Control mode	2	x	x	x	x	x	x	x	P1310[3]	Continuous boost	2	x	x	x	x	x	x	x	P1311[3]	Acceleration boost	2	x	x	x	x	x	x	x	P1312[3]	Starting boost	2	x	x	x	x	x	x	x	P1316[3]	Boost end frequency	3	x	x	x	x	x	x	x	P1320[3]	Programmable V/f freq. coord. 1	3	-	-	-	x	-	-	-	P1321[3]	Programmable V/f volt. coord. 1	3	-	-	-	x	-	-	-	P1322[3]	Programmable V/f freq. coord. 2	3	-	-	-	x	-	-	-	P1323[3]	Programmable V/f volt. coord. 2	3	-	-	-	x	-	-	-	P1324[3]	Programmable V/f freq. coord. 3	3	-	-	-	x	-	-	-	P1325[3]	Programmable V/f volt. coord. 3	3	-	-	-	x	-	-	-	P1330[3]	CI: Voltage setpoint	3	-	-	-	-	-	-	x	P1333[3]	Start frequency for FCC	3	-	x	-	-	-	x	-	P1335[3]	Slip compensation	2	x	x	x	x	-	-	-	P1336[3]	CO: Slip limit	2	x	x	x	x	-	-	-	P1338[3]	Resonance damping gain V/f	3	x	x	x	x	-	-	-	P1340[3]	Imax freq. controller prop. gain	3	x	x	x	x	x	x	x	P1341[3]	Imax controller integral time	3	x	x	x	x	x	x	x	P1345[3]	Imax controller prop. gain	3	x	x	x	x	x	x	x	P1346[3]	Imax voltage ctrl. integral time	3	x	x	x	x	x	x	x	P1350[3]	Voltage soft start	3	x	x	x	x	x	x	x
Par No.	Parameter name	Level	V/f																																																																																																																																																																																																																																																		
			P1300 =																																																																																																																																																																																																																																																		
			0	1	2	3	5	6	19																																																																																																																																																																																																																																												
P1300[3]	Control mode	2	x	x	x	x	x	x	x																																																																																																																																																																																																																																												
P1310[3]	Continuous boost	2	x	x	x	x	x	x	x																																																																																																																																																																																																																																												
P1311[3]	Acceleration boost	2	x	x	x	x	x	x	x																																																																																																																																																																																																																																												
P1312[3]	Starting boost	2	x	x	x	x	x	x	x																																																																																																																																																																																																																																												
P1316[3]	Boost end frequency	3	x	x	x	x	x	x	x																																																																																																																																																																																																																																												
P1320[3]	Programmable V/f freq. coord. 1	3	-	-	-	x	-	-	-																																																																																																																																																																																																																																												
P1321[3]	Programmable V/f volt. coord. 1	3	-	-	-	x	-	-	-																																																																																																																																																																																																																																												
P1322[3]	Programmable V/f freq. coord. 2	3	-	-	-	x	-	-	-																																																																																																																																																																																																																																												
P1323[3]	Programmable V/f volt. coord. 2	3	-	-	-	x	-	-	-																																																																																																																																																																																																																																												
P1324[3]	Programmable V/f freq. coord. 3	3	-	-	-	x	-	-	-																																																																																																																																																																																																																																												
P1325[3]	Programmable V/f volt. coord. 3	3	-	-	-	x	-	-	-																																																																																																																																																																																																																																												
P1330[3]	CI: Voltage setpoint	3	-	-	-	-	-	-	x																																																																																																																																																																																																																																												
P1333[3]	Start frequency for FCC	3	-	x	-	-	-	x	-																																																																																																																																																																																																																																												
P1335[3]	Slip compensation	2	x	x	x	x	-	-	-																																																																																																																																																																																																																																												
P1336[3]	CO: Slip limit	2	x	x	x	x	-	-	-																																																																																																																																																																																																																																												
P1338[3]	Resonance damping gain V/f	3	x	x	x	x	-	-	-																																																																																																																																																																																																																																												
P1340[3]	Imax freq. controller prop. gain	3	x	x	x	x	x	x	x																																																																																																																																																																																																																																												
P1341[3]	Imax controller integral time	3	x	x	x	x	x	x	x																																																																																																																																																																																																																																												
P1345[3]	Imax controller prop. gain	3	x	x	x	x	x	x	x																																																																																																																																																																																																																																												
P1346[3]	Imax voltage ctrl. integral time	3	x	x	x	x	x	x	x																																																																																																																																																																																																																																												
P1350[3]	Voltage soft start	3	x	x	x	x	x	x	x																																																																																																																																																																																																																																												
P1310[0...2]	<b>Continuous boost [%]</b>	0.0 - 250.0	50.0	U, T	PERCENT	DDS	Float	2																																																																																																																																																																																																																																													

7.2 Parameter list

Parameter	Function	Range	Factory default	Can be changed	Scaling	Data set	Data type	Acc. Level
	<p>Defines boost level in [%] relative to P0305 (rated motor current) applicable to both linear and quadratic V/f curves.</p> <p>At low output frequencies the output voltage is low to keep the flux level constant. However, the output voltage may be too low for the following:</p> <ul style="list-style-type: none"> <li>• magnetization the asynchronous motor</li> <li>• hold the load</li> <li>• overcome losses in the system.</li> </ul> <p>The inverter output voltage can be increased via P1310 for the compensation of losses, hold loads at 0 Hz or maintain the magnetization.</p> <p>The magnitude of the boost in Volt at a frequency of zero is defined as follows:  <math>V\_ConBoost,100 = P0305 * Rsadj * (P1310 / 100)</math>                      Where:                      Rsadj = stator resistance adjusted for temperature  <math>Rsadj = (r0395 / 100) * (P0304 / (\sqrt{3} * P0305)) * P0305 * \sqrt{3}</math></p>							
<b>Note:</b>	<p>Increasing the boost levels increases motor heating (especially at standstill).</p> <p>Setting in P0640 (motor overload factor [%]) limits the boost:  <math>sum(V\_Boost) / (P0305 * Rsadj) \leq P1310 / 100</math></p> <p>The boost values are combined when continuous boost (P1310) used in conjunction with other boost parameters (acceleration boost P1311 and starting boost P1312). However priorities are allocated to these parameters as follows:  <math>P1310 &gt; P1311 &gt; P1312</math></p> <p>The total boost is limited by following equation:  <math>sum(V\_Boost) \leq 3 * R\_S * I\_Mot = 3 * P0305 * Rsadj</math></p>							
P1311[0...2]	<b>Acceleration boost [%]</b>	0.0 - 250.0	0.0	U, T	PERCENT	DDS	Float	2
	<p>Applies boost in [%] relative to P0305 (rated motor current) following a positive setpoint change and drops back out once the setpoint is reached.</p> <p>P1311 will only produce boost during ramping, and is therefore useful for additional torque during acceleration and deceleration.</p> <p>As opposed to P1312, which is only active on the first acceleration issued after the ON command, P1311 is always effect during an acceleration and deceleration when issued.</p> <p>The magnitude of the boost in volt at a frequency of zero is defined as follows:  <math>V\_AccBoost,100 = P0305 * Rsadj * (P1311 / 100)</math>                      Where:                      Rsadj = stator resistance adjusted for temperature  <math>Rsadj = (r0395 / 100) * (P0304 / (\sqrt{3} * P0305)) * P0305 * \sqrt{3}</math></p>							
<b>Note:</b>	See P1310							
P1312[0...2]	<b>Starting boost [%]</b>	0.0 - 250.0	0.0	U, T	PERCENT	DDS	Float	2

Parameter	Function	Range	Factory default	Can be changed	Scaling	Data set	Data type	Acc. Level
	<p>Applies a constant linear offset (in [%] relative to P0305 (rated motor current)) to active V/f curve (either linear or quadratic) after an ON command and is active until:</p> <ol style="list-style-type: none"> <li>ramp output reaches setpoint for the first time respectively</li> <li>setpoint is reduced to less than present ramp output</li> </ol> <p>This is useful for starting loads with high inertia. Setting the starting boost (P1312) too high will cause the inverter to limit the current, which will in turn restrict the output frequency to below the setpoint frequency. The magnitude of the boost in volt at a frequency of zero is defined as follows:</p> $V\_StartBoost,100 = P0305 * Rsadj * (P1312 / 100)$ <p>Where:</p> <p>Rsadj = stator resistance adjusted for temperature</p> $Rsadj = (r0395 / 100) * (P0304 / (\sqrt{3} * P0305)) * P0305 * \sqrt{3}$							
<b>Note:</b>	See P1310							
r1315	<b>CO: Total boost voltage [V]</b>	-	-	-	-	-	Float	4
	Displays total value of voltage boost.							
P1316[0...2]	<b>Boost end frequency [%]</b>	0.0 - 100.0	20.0	U, T	PERCENT	DDS	Float	3
	<p>Defines point at which programmed boost reaches 50 % of its value. This value is expressed in [%] relative to P0310 (rated motor frequency). The default frequency is defined as follows:</p> $V\_Boost,min = 2 * (3 + (153 / \sqrt{P\_Motor}))$							
<b>Dependency:</b>	This parameter is influenced by automatic calculations defined by P0340.							
<b>Note:</b>	<p>The expert user may change this value to alter the shape of the curve, e.g. to increase torque at a particular frequency.</p> <p>Default value is depending on inverter type and its rating data.</p>							
P1320[0...2]	<b>Programmable V/f freq. coord. 1 [Hz]</b>	0.00 - 550.00	0.00	T	-	DDS	Float	3
	Sets the frequency of the first point of V/f coordinates (P1320 / 1321 to P1324 / 1325) to define V/f characteristic. These parameter pairs can be used to provide correct torque at correct frequency.							
<b>Dependency:</b>	To set parameter, select P1300 = 3 (V/f with programmable characteristic). The acceleration boost and starting boost defined in P1311 and P1312 are applied to V/f with programmable characteristic.							
<b>Note:</b>	<p>Linear interpolation will be applied between the individual data points.</p> <p>V/f with programmable characteristic (P1300 = 3) has 3 programmable points and 2 non-programmable points. The 2 non-programmable points are:</p> <ul style="list-style-type: none"> <li>Continuous boost P1310 at 0 Hz</li> <li>Rated motor voltage P0304 at rated motor frequency P0310</li> </ul>							
P1321[0...2]	<b>Programmable V/f volt. coord. 1 [V]</b>	0.0 - 3000.0	0.0	U, T	-	DDS	Float	3
	See P1320							
P1322[0...2]	<b>Programmable V/f freq. coord. 2 [Hz]</b>	0.00 - 550.00	0.00	T	-	DDS	Float	3
	See P1320							
P1323[0...2]	<b>Programmable V/f volt. coord. 2 [V]</b>	0.0 - 3000.0	0.0	U, T	-	DDS	Float	3
	See P1320							

Parameter	Function	Range	Factory default	Can be changed	Scaling	Data set	Data type	Acc. Level
P1324[0...2]	<b>Programmable V/f freq. coord. 3 [Hz]</b>	0.00 - 550.00	0.00	T	-	DDS	Float	3
	See P1320							
P1325[0...2]	<b>Programmable V/f volt. coord. 3 [V]</b>	0.0 - 3000.0	0.0	U, T	-	DDS	Float	3
	See P1320							
P1330[0...2]	<b>CI: Voltage setpoint</b>	0 - 4294967295	0	T	-	CDS	U32	3
	BICO parameter for selecting source of voltage setpoint for independent V/f control (P1300 = 19).							
P1333[0...2]	<b>Start frequency for FCC [%]</b>	0.0 - 100.0	10.0	U, T	PERCEN T	DDS	Float	3
	Defines start frequency at which FCC (flux current control) is enabled as [%] of rated motor frequency (P0310).							
<b>Notice:</b>	If this value is too low, the system may become unstable.							
P1334[0...2]	<b>Slip compensation activation range [%]</b>	1.0 - 20.0	6.0	U, T	PERCEN T	DDS	Float	3
	<p>To set the frequency activation range for slip compensation. The percentage value of P1334 refers to the motor rated frequency P0310.</p> <p>The upper threshold will always stay 4 % above P1334.</p> <p>Range of slip compensation:</p>							
<b>Dependency:</b>	Slip compensation (P1335) active.							
<b>Note:</b>	See P1335. The starting frequency of the slip compensation is P1334 * P0310.							
P1335[0...2]	<b>Slip compensation [%]</b>	0.0 - 600.0	0.0	U, T	PERCEN T	DDS	Float	2
	<p>Parameter dynamically adjusts inverter output frequency so that motor speed is kept constant independent of motor load.</p> <p>In the V/f-control, the motor frequency will always be less than the inverter output frequency due to the slip frequency. For a given output frequency, the motor frequency will drop as load is increased. This behavior, typical for induction motors, can be compensated using slip compensation. P1335 can be used to enable and fine-tune the slip compensation.</p>							
<b>Dependency:</b>	Gain adjustment enables fine-tuning of the actual motor speed. P1335 > 0, P1336 > 0, P1337 = 0 if P1300 = 5, 6.							
<b>Notice:</b>	The applied value of the slip compensation (scaled by P1335) is limited by following equation: $f_{Slip\_comp,max} = r0330 * (P1336 / 100)$							



Parameter	Function	Range	Factory default	Can be changed	Scaling	Data set	Data type	Acc. Level
<b>Note:</b>	P1335 = 0 %: Slip compensation disabled. P1335 = 50 % - 70 %: Full slip compensation at cold motor (partial load). P1335 = 100 % (standard setting for warm stator): Full slip compensation at warm motor (full load).							
P1336[0...2]	<b>Slip limit [%]</b>	0 - 600	250	U, T	-	DDS	U16	2
	Compensation slip limit in [%] relative to r0330 (rated motor slip), which is added to frequency setpoint.							
<b>Dependency:</b>	Slip compensation (P1335) active.							
r1337	<b>CO: V/f slip frequency [%]</b>	-	-	-	PERCENT T	-	Float	3
	Displays actual compensated motor slip as [%]. $f\_slip [Hz] = r1337 [\%] * P0310 / 100$							
<b>Dependency:</b>	Slip compensation (P1335) active.							
P1338[0...2]	<b>Resonance damping gain V/f</b>	0.00 - 10.00	0.00	U, T	-	DDS	Float	3
	Defines resonance damping gain for V/f. The di / dt of the active current will be scaled by P1338. If di / dt increases the resonance damping circuit decreases the inverter output frequency.							
<b>Dependency:</b>	This parameter is influenced by automatic calculations defined by P0340.							
<b>Note:</b>	The resonance circuit damps oscillations of the active current which frequently occur during no-load operation. In V / f modes (see P1300), the resonance damping circuit is active in a range from approx. 6 % to 80 % of rated motor frequency (P0310). If the value of P1338 is too high, this will cause instability (forward control effect).							
P1340[0...2]	<b>I<sub>max</sub> controller proportional gain</b>	0.000 - 0.499	0.030	U, T	-	DDS	Float	3
	Proportional gain of the I <sub>max</sub> controller. The I <sub>max</sub> controller reduces inverter current if the output current exceeds the maximum motor current (r0067). In linear V/f, parabolic V/f, FCC, and programmable V/f modes the I <sub>max</sub> controller uses both a frequency controller (see P1340 and P1341) and a voltage controller (see P1345 and P1346). The frequency controller seeks to reduce current by limiting the inverter output frequency (to a minimum of the two times nominal slip frequency). If this action does not successfully remove the overcurrent condition, the inverter output voltage is reduced using the I <sub>max</sub> voltage controller. When the overcurrent condition has been removed successfully, frequency limiting is removed using the ramp-up time set in P1120. In linear V/f for textiles, FCC for textiles, or external V/f modes only the I <sub>max</sub> voltage controller is used to reduce current (see P1345 and P1346).							
<b>Note:</b>	The I <sub>max</sub> controller can be disabled by setting the frequency controller integral time P1341 to zero. This disables both the frequency and voltage controllers. Note that when disabled, the I <sub>max</sub> controller will take no action to reduce current but overcurrent warnings will still be generated, and the inverter will trip in excessive overcurrent or overload conditions.							
P1341[0...2]	<b>I<sub>max</sub> controller integral time [s]</b>	0.000 - 50.000	0.300	U, T	-	DDS	Float	3
	Integral time constant of the I <sub>max</sub> controller. <ul style="list-style-type: none"> <li>• P1341 = 0: I<sub>max</sub> controller disabled</li> <li>• P1340 = 0 and P1341 &gt; 0: frequency controller enhanced integral</li> <li>• P1340 &gt; 0 and P1341 &gt; 0: frequency controller normal PI control</li> </ul>							
<b>Dependency:</b>	This parameter is influenced by automatic calculations defined by P0340.							
<b>Note:</b>	See P1340 for further information. The Factory setting depends on inverter power.							

Parameter list

7.2 Parameter list

Parameter	Function	Range	Factory default	Can be changed	Scaling	Data set	Data type	Acc. Level
r1343	<b>CO: I<sub>max</sub> controller frequency output [Hz]</b>	-	-	-	-	-	Float	3
	Displays effective frequency limitation.							
<b>Dependency:</b>	If I <sub>max</sub> controller not in operation, parameter normally shows maximum frequency P1082.							
r1344	<b>CO: I<sub>max</sub> controller voltage output [V]</b>	-	-	-	-	-	Float	3
	Displays amount by which the I <sub>max</sub> controller is reducing the inverter output voltage.							
P1345[0...2]	<b>I<sub>max</sub> voltage controller proportional gain</b>	0.000 - 5.499	0.250	U, T	-	DDS	Float	3
	If the output current (r0068) exceeds the maximum current (r0067), the inverter is dynamically controlled by reducing the output voltage. This parameter sets the proportional gain of this controller.							
<b>Dependency:</b>	This parameter is influenced by automatic calculations defined by P0340.							
<b>Note:</b>	See P1340 for further information. The Factory setting depends on inverter power.							
P1346[0...2]	<b>I<sub>max</sub> voltage controller integral time [s]</b>	0.000 - 50.000	0.300	U, T	-	DDS	Float	3
	Integral time constant of the I <sub>max</sub> voltage controller. <ul style="list-style-type: none"> <li>• P1341 = 0: I<sub>max</sub> controller disabled</li> <li>• P1345 = 0 and P1346 &gt; 0: I<sub>max</sub> voltage controller enhanced integral</li> <li>• P1345 &gt; 0 and P1346 &gt; 0: I<sub>max</sub> voltage controller normal PI control</li> </ul>							
<b>Dependency:</b>	This parameter is influenced by automatic calculations defined by P0340.							
<b>Note:</b>	See P1340 for further information. The Factory setting depends on inverter power.							
r1348	<b>Economy mode factor [%]</b>	-	-	-	PERCENT	-	Float	2
	Displays the calculated economy mode factor (range 80%-120%) applied to the demanded output volts. Economy mode is used to find the most efficient operating point for a given load. It does this by a continuous method of hill climbing optimization. Hill climbing optimization works by slightly changing the output volts either up or down and monitoring the change in input power. If the input power has decreased, the algorithm changes the output volts in the same direction. If the input power has increased then the algorithm adjusts the output volts in the other direction. Using this algorithm, the software should be able to find the minimum point on the graph between input power and output volts.							
<b>Notice:</b>	If this value is too low, the system may become unstable.							
P1350[0...2]	<b>Voltage soft start</b>	0 - 1	0	U, T	-	DDS	U16	3
	Sets whether voltage is built up smoothly during magnetization time (ON) or whether it simply jumps to boost voltage (OFF).							
	0	OFF						
	1	ON						
<b>Note:</b>	The settings for this parameter bring benefits and drawbacks: <ul style="list-style-type: none"> <li>• P1350 = 0: OFF (jump to boost voltage) <ul style="list-style-type: none"> <li>Benefit: flux is built up quickly</li> <li>Drawback: motor may move</li> </ul> </li> <li>• P1350 = 1: ON (smooth voltage build-up) <ul style="list-style-type: none"> <li>Benefit: motor less likely to move</li> <li>Drawback: flux build-up takes longer</li> </ul> </li> </ul>							

Parameter	Function	Range	Factory default	Can be changed	Scaling	Data set	Data type	Acc. Level
P1780[0...2]	<b>Control word of Rs/Rr-adaption</b>	0 - 1	1	U, T	-	DDS	U16	3
	Enables thermal adaptation of stator and rotor resistance to reduce torque errors in speed / torque regulation with speed sensor, or speed errors in speed / torque regulation without speed sensor.							
	<b>Bit</b>	<b>Signal name</b>			<b>1 signal</b>		<b>0 signal</b>	
	00	Enable thermal Rs/Rr-adapt.			Yes		No	
P1800[0...2]	<b>Pulse frequency [kHz]</b>	2 - 16	4	U, T	-	DDS	U16	2
	Sets pulse frequency of power switches in inverter. The frequency can be changed in steps of 2 kHz.							
<b>Dependency:</b>	The minimum / maximum / default values of the pulse frequency are determined by the used power module. Furthermore the minimum pulse frequency depends on the parameterization of P1082 (maximum frequency) and P0310 (rated motor frequency).							
<b>Note:</b>	If the pulse frequency is increased, maximum inverter current r0209 can be reduced (derating). The derating characteristic depends on the type and power of the inverter. If silent operation is not absolutely necessary, lower pulse frequencies may be selected to reduce inverter losses and radio-frequency emissions. Under certain circumstances, the inverter may reduce the pulse frequency to provide protection against overtemperature (see P0290 and P0291 bit 00).							
r1801[0...1]	<b>CO: Pulse frequency [kHz]</b>	-	-	-	-	-	U16	3
	Displays information about pulse frequency of power switches in inverter. r1801[0] displays the actual inverter pulse frequency. r1801[1] displays the minimum inverter pulse frequency which can be reached when the functions "motor identification" or "inverter overload reaction" are active. If no PM is plugged this parameter is set to 0 kHz.							
<b>Index:</b>	[0]	Actual pulse frequency						
	[1]	Minimum pulse frequency						
<b>Notice:</b>	Under certain conditions (inverter overtemperature, see P0290), this can differ from the values selected in P1800 (pulse frequency).							
P1802	<b>Modulator mode</b>	1 - 3	3	U, T	-	-	U16	3
	Selects inverter modulator mode.							
	1	Asymmetric SVM						
	2	Space vector modulation						
	3	SVM / ASVM controlled mode						
<b>Notice:</b>	<ul style="list-style-type: none"> <li>Asymmetric space vector modulation (ASVM) produces lower switching losses than space vector modulation (SVM), but may cause irregular rotation at very low speeds.</li> <li>Space vector modulation (SVM) with over-modulation may produce current waveform distortion at high output voltages.</li> <li>Space vector modulation (SVM) without over-modulation will reduce maximum output voltage available to motor.</li> </ul>							
P1803[0...2]	<b>Maximum modulation [%]</b>	20.0 - 150.0	106.0	U, T	-	DDS	Float	3
	Sets maximum modulation index.							
<b>Note:</b>	P1803 = 100 %: Limit for over-control (for ideal inverter without switching delay).							
P1810[0...2]	<b>Control word Vdc control</b>	0 - 3	3	U, T	-	-	U16	3
	Configures Vdc filtering and compensation.							

Parameter list

7.2 Parameter list

Parameter	Function	Range	Factory default	Can be changed	Scaling	Data set	Data type	Acc. Level
	<b>Bit</b>	<b>Signal name</b>			<b>1 signal</b>		<b>0 signal</b>	
	00	Enable Vdc average filter			Yes		No	
	01	Enable Vdc compensation			Yes		No	
<b>Index:</b>	[0]	Inverter data set 0 (DDS0)						
	[1]	Inverter data set 1 (DDS1)						
	[2]	Inverter data set 2 (DDS2)						
<b>Note:</b>	P1810 default for the single phase variants is 2.							
P1820[0...2]	<b>Reverse output phase sequence</b>	0 - 1	0	T	-	DDS	U16	2
	Changes sequence of phases without changing setpoint polarity.							
	0	Forward						
	1	Reverse the Motor						
<b>Note:</b>	See P1000							
P1825	<b>On-state voltage of IGBT [V]</b>	0.0 - 20.0	0.9	U, T	-	-	Float	4
	Corrects on-state voltage of the IGBTs.							
P1828	<b>Gating unit dead time [µs]</b>	0.00 - 3.98	0.01	U, T	-	-	Float	4
	Sets compensation time of gating unit interlock.							
P1900	<b>Select motor data identification</b>	0 - 2	0	C, T	-	-	U16	2
	Performs motor data identification.							
	0	Disabled						
	2	Identification of all parameters in standstill						
<b>Dependency:</b>	No measurement if motor data incorrect. P1900 = 2: Calculated value for stator resistance (see P0350) is overwritten.							
<b>Notice:</b>	When the identification is finished P1900 is set to 0. When choosing the setting for measurement, observe the following: The value is actually adopted as P0350 parameter setting and applied to the control as well as being shown in the read-only parameters below. Ensure that the motor holding brake is not active when performing the motor identification.							
<b>Note:</b>	Before selecting motor data identification, "Quick commissioning" has to be performed in advance. Since the cable length of the applications differs in a wide range, the preset resistor P0352 is only a rough estimation. Better results of the motor identification can be achieved by specifying the cable resistor before the start of the motor identification by measuring / calculating. Once enabled (P1900 > 0), A541 generates a warning that the next ON command will initiate measurement of motor parameters. Communications - both via USS as well as via the Modbus - are interrupted for the time that it takes to make internal calculations. These calculations can take up to one minute to complete.							
P1909[0...2]	<b>Control word of motor data identification</b>	0 - 65519	23552	U, T	-	DDS	U16	4
	Control word of motor data identification.							
	<b>Bit</b>	<b>Signal name</b>			<b>1 signal</b>		<b>0 signal</b>	
	00	Estimation of Xs			Yes		No	
	01	Motor ID at 2 kHz			Yes		No	

Parameter	Function	Range	Factory default	Can be changed	Scaling	Data set	Data type	Acc. Level
	02	Estimation of Tr			Yes		No	
	03	Estimation of Lsigma			Yes		No	
	05	Det. Tr meas. with 2 freq.			Yes		No	
	06	Measurement of on voltage			Yes		No	
	07	Deadtime detection from Rs measurement			Yes		No	
	08	MotID with hw deadtime comp activ			Yes		No	
	09	No deadtime detection with 2 freq			Yes		No	
	10	Detect Ls with LsBlock method			Yes		No	
	11	MotID adaption of magnetizing current			Yes		No	
	12	MotID adaption of main reactance			Yes		No	
	13	MotID switch off saturation curve optim.			Yes		No	
	14	MotID saturation curve optim. all framesizes			Yes		No	
	15	MotID saturation curve optim. big framesizes			Yes		No	
P1910	<b>Select motor data identification</b>	0 - 23	0	T	-	-	U16	4
	Performs a motor data identification with extended figures. Performs stator resistance measuring.							
	0	Disabled						
	1	Identification of all parameters with parameter change						
	2	Identification of all parameters without parameter change						
	3	Identification of saturation curve with parameter change						
	4	Identification of saturation curve without parameter change						
	5	Identification of XsigDyn without parameter change						
	6	Identification of Tdead without parameter change						
	7	Identification of Rs without parameter change						
	8	Identification of Xs without parameter change						
	9	Identification of Tr without parameter change						
	10	Identification of Xsigma without parameter change						
	20	Set voltage vector						
	21	Set voltage vector without filtering in r0069						
	22	Set voltage vector rectangle signal						
	23	Set voltage vector triangle signal						
<b>Notice:</b>	<p>Ensure that the motor holding brake is not active when performing the motor identification. P1910 can't be changed while the motor identification with P1900 is active (P1900 = 2 or 3). When the identification is finished P1910 is set to 0. When choosing the setting for measurement, observe the following:</p> <ul style="list-style-type: none"> <li>"with parameter change" means that the value is actually adopted as P0350 parameter setting and applied to the control as well as being shown in the read-only parameters below.</li> <li>"without parameter change" means that the value is only displayed, i.e. shown for checking purposes in the read-only parameter r1912 (identified stator resistance). The value is not applied to the control.</li> </ul>							

7.2 Parameter list

Parameter	Function	Range	Factory default	Can be changed	Scaling	Data set	Data type	Acc. Level
<b>Dependency:</b>	No measurement if motor data incorrect. P1910 = 1: Calculated value for stator resistance (see P0350) is overwritten.							
<b>Note:</b>	See P1900							
r1912[0]	<b>Identified stator re- sistance [Ω]</b>	-	-	-	-	-	Float	4
	Displays measured stator resistance value (line-to-line). This value also includes the cable resistances.							
<b>Index:</b>	[0]	U_phase						
<b>Notice:</b>	If the value identified (Rs = stator resistance) does not lie within the range 0.1 % < Rs [p. u.] < 100 % fault message 41 (motor data identification failure) is issued. P0949 provides further information (fault value = 2 in this case).							
<b>Note:</b>	This value is measured using P1900 = 2.							
r1920[0]	<b>Identified dynamic leak- age inductance</b>	-	-	-	-	-	Float	4
	Displays identified total dynamic leakage inductance.							
<b>Index:</b>	[0]	U_phase						
r1925[0]	<b>Identified on-state voltage [V]</b>	-	-	-	-	-	Float	4
	Displays identified on-state voltage of IGBT.							
<b>Index:</b>	[0]	U_phase						
<b>Notice:</b>	If the identified on-state voltage does not lie within the range 0.0V < 10V fault message 41 (motor data identification failure) is issued. P0949 provides further information (fault value = 20 in this case).							
r1926	<b>Identified gating unit dead time [μs]</b>	-	-	-	-	-	Float	2
	Displays identified dead time of gating unit interlock.							
P2000[0...2]	<b>Reference frequency [Hz]</b>	1.00 - 550.00	50.00	⊤	-	DDS	Float	2
	P2000 represents the reference frequency for frequency values which are displayed / transferred as a percentage or a hexadecimal value. Where: <ul style="list-style-type: none"> <li>hexadecimal 4000 H ==&gt; P2000 (e.g.: USS-PZD)</li> <li>percentage 100 % ==&gt; P2000 (e.g.: analog input)</li> </ul>							
<b>Example:</b>	<p>If a BICO connection is made between two parameters or alternatively using P0719 or P1000, the 'unit' of the parameters (standardized (Hex) or physical (i.e. Hz) values) may differ. SINAMICS implicitly makes an automatic conversion to the target value.</p>							
<b>Dependency:</b>	When Quick Commissioning is carried out, P2000 is changed as follows: P2000 = P1082.							



Parameter	Function	Range	Factory default	Can be changed	Scaling	Data set	Data type	Acc. Level
	Full-scale reference torque used over the serial link (corresponds to 4000H).							
<b>Example:</b>	If a BICO connection is made between two parameters, the 'unit' of the parameters (standardized (Hex) or physical (i.e. Nm) values) may differ. In this case an automatic conversion to the target value is made. $y[\text{Hex}] = \frac{r0080[\text{Nm}]}{P2003[\text{Nm}]} \cdot 4000[\text{Hex}]$							
<b>Dependency:</b>	This parameter is influenced by automatic calculations defined by P0340.							
<b>Note:</b>	Changes to P2003 result in a new calculation of P2004.							
P2004[0...2]	<b>Reference power</b>	0.01 - 2000.0	0.75	T	-	DDS	Float	3
	Full-scale reference power used over the serial link (corresponds to 4000H).							
<b>Example:</b>	If a BICO connection is made between two parameters, the 'unit' of the parameters (standardized (Hex) or physical (i.e. kW / hp) values) may differ. In this case an automatic conversion to the target value is made. $y[\text{Hex}] = \frac{r0032}{P2004} \cdot 4000[\text{Hex}]$							
P2010[0...1]	<b>USS / MODBUS baudrate</b>	6 - 12	6	U, T	-	-	U16	2
	Sets baud rate for USS / MODBUS communication.							
	6	9600 bps						
	7	19200 bps						
	8	38400 bps						
	9	57600 bps						
	10	76800 bps						
	11	93750 bps						
	12	115200 bps						
<b>Index:</b>	[0]	USS / MODBUS on RS485						
	[1]	USS on RS232 (reserved)						
<b>Note:</b>	This parameter, index 0, will alter the baudrate on RS485 regardless of the protocol selected in P2023.							
P2011[0...1]	<b>USS address</b>	0 - 31	0	U, T	-	-	U16	2
	Sets unique address for inverter.							
<b>Index:</b>	[0]	USS / MODBUS on RS485						
	[1]	USS on RS232 (reserved)						
<b>Note:</b>	You can connect up to a further 30 inverters via the serial link (i.e. 31 inverters in total) and control them with the USS serial bus protocol.							
P2012[0...1]	<b>USS PZD length</b>	0 - 8	2	U, T	-	-	U16	3
	Defines the number of 16-bit words in PZD part of USS telegram. In this area, process data (PZD) are continually exchanged between the master and slaves. The PZD part of the USS telegram is used for the main setpoint, and to control the inverter.							
<b>Index:</b>	[0]	USS / MODBUS on RS485						
	[1]	USS on RS232 (reserved)						

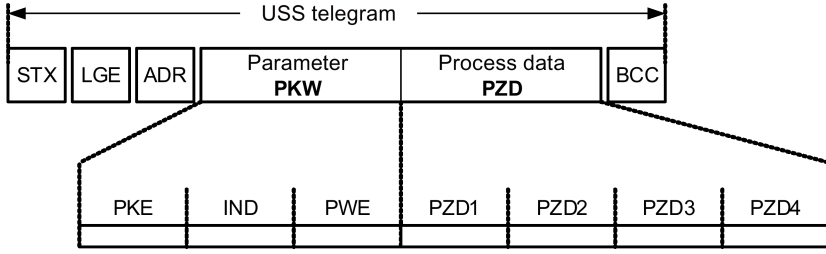
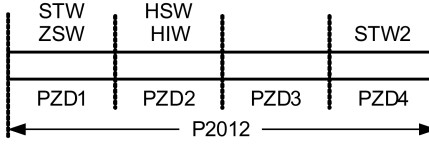

Parameter	Function	Range	Factory default	Can be changed	Scaling	Data set	Data type	Acc. Level
<b>Notice:</b>	<p>USS protocol consists of PZD and PKW which can be changed by the user via P2012 and P2013 respectively.</p>  <p>STX Start of text LGE Length ADR Address PKW Parameter ID value PZD Process data BCC Block check character</p> <p>PKE Parameter ID IND Sub-index PWE Parameter value</p>							
	<p>PZD transmits a control word and setpoint or status word and actual values. The number of PZD-words in a USS-telegram are determined by P2012, where the first two words are either:</p> <p>a) control word and main setpoint or b) status word and actual value.</p> <p>When P2012 is greater or equal to 4 the additional control word is transferred as the 4th PZD-word (default setting).</p>  <p>STW Control word ZSW Status word PZD Process data</p> <p>HSW Main setpoint HIW Main actual value</p>							
P2013[0...1]	<b>USS PKW length</b>	0 - 127	127	U, T	-	-	U16	3
	<p>Defines the number of 16-bit words in PKW part of USS telegram. The PKW area can be varied. Depending on the particular requirement, 3-word, 4-word or variable word lengths can be parameterized. The PKW part of the USS telegram is used to read and write individual parameter values.</p>							
	0	No words						
	3	3 words						
	4	4 words						
	127	Variable						
<b>Example:</b>		Data type						
		U16 (16 Bit)	U32 (32 Bit)		Float (32 Bit)			
	P2013 = 3	X	Parameter access fault		Parameter access fault			
	P2013 = 4	X	X	X		X		
	P2013 = 127	X	X	X		X		
<b>Index:</b>	[0]	USS / MODBUS on RS485						
	[1]	USS on RS232 (reserved)						

Parameter	Function	Range	Factory default	Can be changed	Scaling	Data set	Data type	Acc. Level
<b>Notice:</b>	<p>USS protocol consists of PZD and PKW which can be changed by the user via P2012 and P2013 respectively. P2013 determines the number of PKW-words in a USS-telegram. Setting P2013 to 3 or 4 determines the length of the PKW words (3 = three words and 4 = four words). When P2013 set to 127 automatically adjusts the length of the PKW words are required.</p> <div style="display: flex; flex-direction: column; align-items: center;"> <div style="display: flex; align-items: center; margin-bottom: 10px;"> <div style="margin-right: 10px;">P2013 = 3</div> </div> <div style="display: flex; align-items: center;"> <div style="margin-right: 10px;">P2013 = 4</div> </div> <div style="margin-top: 10px; text-align: center;"> <p>PKE    Parameter ID  IND    Sub-index  PWE    Parameter value</p> </div> </div> <p>If a fixed PKW length is selected only one parameter value can be transferred.  In the case of indexed parameter, you must use the variable PKW length if you wish to have the values of all indices transferred in a single telegram.  In selecting the fixed PKW length, it is important to ensure the value in question can be transferred using this PKW length.  P2013 = 3, fixes PKW length, but does not allow access to many parameter values.  A parameter fault is generated when an out-of-range value is used, the value will not be accepted but the inverter state will not be affected.  Useful for applications where parameters are not changed, but MM3s are also used.  Broadcast mode is not possible with this setting.  P2013 = 4, fixes PKW length.  Allows access to all parameters, but indexed parameters can only be read one index at a time.  Word order for single word values are different to setting 3 or 127, see example below.  P2013 = 127, most useful setting.  PKW reply length varies depending on the amount of information needed.  Can read fault information and all indices of a parameter with a single telegram with this setting.  Example:  Set P0700 to value 5 (P0700 = 2BC (hex))</p>							
		P2013 = 3		P2013 = 4		P2013 = 127		
	Master → SINAMICS	22BC 0000 0006		22BC 0000 0000 0006		22BC 0000 0006 0000		
	SINAMICS → Master	12BC 0000 0006		12BC 0000 0000 0006		12BC 0000 0006		
P2014[0...1]	<b>USS / MODBUS telegram off time [ms]</b>	0 - 65535	2000	T	-	-	U16	3
	<p>Index 0 defines a time T<sub>off</sub> after which a fault will be generated (F72) if no telegram is received via the USS / MODBUS channel RS485.  Index 1 defines a time T<sub>off</sub> after which a fault will be generated (F71) if no telegram is received via the USS channel RS232 (reserved).</p>							
<b>Index:</b>	[0]	USS / MODBUS on RS485						
	[1]	USS on RS232 (reserved)						
<b>Notice:</b>	If time set to 0, no fault is generated (i.e. watchdog disabled).							
<b>Note:</b>	The telegram off time will function on RS485 regardless of the protocol set in P2023.							
r2018[0...7]	<b>CO: PZD from USS/MODBUS on RS485</b>	-	-	-	4000H	-	U16	3
	Displays process data received via USS/MODBUS on RS485.							

Parameter	Function	Range	Factory default	Can be changed	Scaling	Data set	Data type	Acc. Level
	USS on RS485:							
	<p>USS telegram structure:</p> <p>USS telegram: BCC   PZD Process data   PKW Parameter   ADR   LGE   STX</p> <p>USS on RS485: [USS telegram]   [STW Control word]   [HSW Main setpoint]</p> <p><b>PZD mapping to parameter r2018</b></p>							
	<p>BO: CtrlWd1 &lt;- COM</p> <p>r2036</p> <ul style="list-style-type: none"> <li>Bit 00 ON/OFF1</li> <li>Bit 01 OFF2: Electrical stop</li> <li>Bit 02 OFF3: Fast stop</li> <li>Bit 03 Pulse enable</li> <li>Bit 04 RFG enable</li> <li>Bit 05 RFG start</li> <li>Bit 06 Setpoint enable</li> <li>Bit 07 Fault acknowledge</li> <li>Bit 08 JOG right</li> <li>Bit 09 JOG left</li> <li>Bit 10 Control from PLC</li> <li>Bit 11 Reverse (setpoint inversion)</li> <li>Bit 13 Motor potentiometer MOP up</li> <li>Bit 14 Motor potentiometer MOP down</li> <li>Bit 15 CDS Bit 0 (Local/Remote)</li> </ul>							
	<p>BO: CtrlWd2 &lt;- COM</p> <p>r2018</p> <ul style="list-style-type: none"> <li>Bit 00 Fixed frequency Bit 0</li> <li>Bit 01 Fixed frequency Bit 1</li> <li>Bit 02 Fixed frequency Bit 2</li> <li>Bit 03 Fixed frequency Bit 3</li> <li>Bit 04 Drive data set (DDS) Bit 0</li> <li>Bit 05 Drive data set (DDS) Bit 1</li> <li>Bit 08 PID enabled</li> <li>Bit 09 DC brake enabled</li> <li>Bit 11 Droop</li> <li>Bit 12 Torque control</li> <li>Bit 13 External fault 1</li> <li>Bit 15 Command data set (CDS) Bit 1</li> </ul>							
	<p>Note:</p> <p>Bit 10 must be set in the first PZD word of the telegram received via USS so that the converter will accept the process data as being valid. For this reason, the control word 1 must be transferred to the converter in the first PZD word.</p>							

Parameter	Function	Range	Factory default	Can be changed	Scaling	Data set	Data type	Acc. Level
	<p>MODBUS on RS485:</p> <p>HSW (speed setpoint) 40003 or 40101</p> <p>Bit: 0 1 2 3 4 5 6 7 8 9 10 11 12 13 14 15</p> <p>40006 STW0    40004 STW3    40007 STW7    40005 STW11</p> <p>40100 STW</p> <p>MODBUS telegram</p> <p>MODBUS on RS485</p> <p>Mapping to parameter r2018</p> <p>STW (control word):</p> <p>Bit 00  <input checked="" type="checkbox"/> =ON (Pulses can be enabled)                      0 =OFF1 (braking with ramp-function generator, then pulse cancellation and ready-to-power-up)</p> <p>Bit 01                      1=No OFF2 (enable is possible)                      0=OFF2 (immediate pulse cancellation and power-on inhibit)</p> <p>Bit 02                      1=No OFF3 (enable is possible)                      0=OFF3 (braking with the OFF3 ramp p1135, then pulse cancellation and power-on inhibit)</p> <p>Bit 03                      1=Enable operation (pulses can be enabled)                      0=Inhibit operation (cancel pulses)</p> <p>Bit 04                      1=Operation condition (the ramp-function generator can be enabled)                      0=Inhibit ramp-function generator (set the ramp-function generator output to zero)</p> <p>Bit 05                      1=Enable the ramp-function generator                      0=Stop the ramp-function generator (freeze the ramp-function generator output)</p> <p>Bit 06                      1=Enable setpoint                      0=Inhibit setpoint (set the ramp-function generator input to zero)</p> <p>Bit 07  <input checked="" type="checkbox"/> =Acknowledge faults</p> <p>Bit 08 Reserved                      Bit 09 1=Reserved                      Bit 10 1=Control via PLC                      Bit 11 1=Dir of rot reversal                      Bit 12 Reserved                      Bit 13 1=Motorized potentiometer, setpoint, raise                      Bit 14 1=Motorized potentiometer, setpoint, lower                      Bit 15 Reserved</p>							
<b>Index:</b>	[0]	Received word 0						
	[1]	Received word 1						
	...	...						
	[7]	Received word 7						
<b>Note:</b>	<p>Restrictions:</p> <ul style="list-style-type: none"> <li>• If the above serial interface controls the inverter (P0700 or P0719) then the 1st control word must be transferred in the 1st PZD-word.</li> <li>• If the setpoint source is selected via P1000 or P0719, then the main setpoint must be transferred in the 2nd PZD-word.</li> <li>• When P2012 is greater than or equal to 4 the additional control word (2nd control word) must transferred in the 4th PZD-word, if the above serial interface controls the inverter (P0700 or P0719).</li> </ul>							
P2019[0...7]	<b>Ci: PZD to USS / MODBUS on RS485</b>	-	52[0]	T	4000H	-	U32 / I16	3
Displays process data transmitted via USS/MODBUS on RS485.								

Parameter	Function	Range	Factory default	Can be changed	Scaling	Data set	Data type	Acc. Level
	<p>USS on RS485:</p> <ul style="list-style-type: none"> <li>Bit 00 DC brake active</li> <li>Bit 01 Act. freq. r0021 &gt; P2167 (f_off)</li> <li>Bit 02 Act. freq. r0021 &gt; P1080 (f_min)</li> <li>Bit 03 Act. current r0027 &gt;= P2170</li> <li>Bit 04 Act. freq. r0021 &gt;= P2155 (f_1)</li> <li>Bit 05 Act. freq. r0021 &lt; P2155 (f_1)</li> <li>Bit 06 Act. freq. r0021 &gt;= setpoint</li> <li>Bit 07 Act. Vdc r0026 &lt; P2172</li> <li>Bit 08 Act. Vdc r0026 &gt; P2172</li> <li>Bit 09 Ramping finished</li> <li>Bit 10 PID output r2294 == P2292 (PID_min)</li> <li>Bit 11 PID output r2294 == P2291 (PID_max)</li> <li>Bit 14 Download data set 0 from AOP</li> <li>Bit 15 Download data set 1 from AOP</li> </ul>							
	<ul style="list-style-type: none"> <li>Bit 00 Drive ready</li> <li>Bit 01 Drive ready to run</li> <li>Bit 02 Drive running</li> <li>Bit 03 Drive fault active</li> <li>Bit 04 OFF2 active</li> <li>Bit 05 OFF3 active</li> <li>Bit 06 ON inhibit active</li> <li>Bit 07 Drive warning active</li> <li>Bit 08 Deviation setpoint/act. value</li> <li>Bit 09 PZD control</li> <li>Bit 10 Maximum frequency reached</li> <li>Bit 11 Warning: Motor current limit</li> <li>Bit 12 Motor holding brake active</li> <li>Bit 13 Motor overload</li> <li>Bit 14 Motor runs right</li> <li>Bit 15 Inverter overload</li> </ul>							
	<p>CO/BO: Act StatWd1</p> <p>CO: Act. frequency [Hz]</p> <p>r0021</p> <p>CO/BO: Act StatWd2</p> <p>r0053</p> <p>r0053</p> <p>P2019</p> <p>[0]</p> <p>[1]</p> <p>[2]</p> <p>[3]</p> <p>...</p> <p>[7]</p> <p>PZD4</p> <p>PZD3</p> <p>PZD2</p> <p>PZD1</p> <p>ZSW2</p> <p>HIW</p> <p>ZSW1</p> <p>P2012</p> <p>BCC</p> <p>PZD</p> <p>Process data</p> <p>PKW</p> <p>Parameter</p> <p>ADR</p> <p>LGE</p> <p>STX</p> <p>USS telegram</p> <p>PZD mapping from parameter P2019</p> <p>USS on RS485</p>							
	<p>STX Start of text</p> <p>LGE Length</p> <p>ADR Address</p> <p>PKW Parameter ID value</p> <p>PZD Process data</p> <p>BCC Block check character</p> <p>ZSW Status word</p> <p>HIW Main actual value</p> <p>Note: P2019[0] = 52, P2019[1] = 21, P2019[3] = 53 are default settings.</p>							

Parameter	Function	Range	Factory default	Can be changed	Scaling	Data set	Data type	Acc. Level
	<p>MODBUS on RS485:</p> <p>CO/BO: Act StatWd1</p> <p>r0052</p> <p>r0021</p> <p>CO: Act. frequency [Hz]</p> <p>P2019</p> <p>Bit: 0 1 2 3 4 5 6 7 8 9 10 11 12 13 14 15</p> <p>40038 ZSW0</p> <p>40039 ZSW1</p> <p>40035 ZSW2</p> <p>40054 ZSW3</p> <p>40059 ZSW7</p> <p>40037 ZSW9</p> <p>40036 ZSW9</p> <p>40034 ZSW14</p> <p>40110 ZSW</p> <p>MODBUS telegram</p> <p>Mapping from parameter P2019</p> <p>MODBUS on RS485</p> <p>HIW (actual speed)</p> <p>40044 or 40111</p> <p>ZSW (status word):</p> <p>Bit 00 1=Ready to power-up</p> <p>Bit 01 1=Ready to operate (DC link loaded, pulses blocked)</p> <p>Bit 02 1=Operation enabled (drive follows n_set)</p> <p>Bit 03 1=Fault present</p> <p>Bit 04 1=No coast down active (OFF2 inactive)</p> <p>Bit 05 1=No fast stop active (OFF3 inactive)</p> <p>Bit 06 1=Power-on inhibit active</p> <p>Bit 07 1=Alarm present</p> <p>Bit 08 1=Speed setpoint - actual value deviation within tolerance t_off</p> <p>Bit 09 1=Control requested</p> <p>Bit 10 1=f or n comparison value reached/exceeded</p> <p>Bit 11 1=M, or P limit not reached</p> <p>Bit 12 Reserved</p> <p>Bit 13 1=No motor overtemperature alarm</p> <p>Bit 14</p> <p>1=Motor rotates forwards (n_act &gt;= 0)</p> <p>0=Motor rotates backwards (n_act &lt; 0)</p> <p>Bit 15 1=No alarm, thermal overload, power unit</p>							
<b>Index:</b>	[0]	Transmitted word 0						
	[1]	Transmitted word 1						
	...	...						
	[7]	Transmitted word 7						
<b>Note:</b>	If r0052 not indexed, display does not show an index ("0").							
P2021	<b>Modbus address</b>	1 - 247	1	T	-	-	U16	2
	Sets unique address for inverter.							

Parameter	Function	Range	Factory default	Can be changed	Scaling	Data set	Data type	Acc. Level
P2022	<b>Modbus reply timeout [ms]</b>	0 - 10000	1000	U, T	-	-	U16	3
	The time in which the inverter is allowed to respond to the Modbus master. If the forming of a response needs more time than specified in this parameter, the processing is done, but no response is sent.							
P2023	<b>RS485 protocol selection</b>	0 - 2	1	T	-	-	U16	1
	Select the protocol which runs on the RS485 link.							
	0	None						
	1	USS						
	2	Modbus						
<b>Note:</b>	After changing P2023, powercycle the inverter. During the powercycle, wait until LED has gone off or the display has gone blank (may take a few seconds) before re-applying power. If P2023 has been changed via a PLC, make sure the change has been saved to EEPROM via P0971.							
r2024[0...1]	<b>USS / MODBUS error-free telegrams</b>	-	-	-	-	-	U16	3
	Displays number of error-free USS / MODBUS telegrams received.							
<b>Index:</b>	[0]	USS / MODBUS on RS485						
	[1]	USS on RS232 (reserved)						
<b>Note:</b>	The state of the telegram information on RS485 is reported regardless of the protocol set in P2023.							
r2025[0...1]	<b>USS / MODBUS rejected telegrams</b>	-	-	-	-	-	U16	3
	Displays number of USS / MODBUS telegrams rejected.							
<b>Index:</b>	See r2024							
<b>Note:</b>	See r2024							
r2026[0...1]	<b>USS / MODBUS character frame error</b>	-	-	-	-	-	U16	3
	Displays number of USS / MODBUS character frame errors.							
<b>Index:</b>	See r2024							
<b>Note:</b>	See r2024							
r2027[0...1]	<b>USS / MODBUS overrun error</b>	-	-	-	-	-	U16	3
	Displays number of USS / MODBUS with overrun error.							
<b>Index:</b>	See r2024							
<b>Note:</b>	See r2024							
r2028[0...1]	<b>USS / MODBUS parity error</b>	-	-	-	-	-	U16	3
	Displays number of USS / MODBUS telegrams with parity error.							
<b>Index:</b>	See r2024							
<b>Note:</b>	See r2024							
r2029[0...1]	<b>USS start not identified</b>	-	-	-	-	-	U16	3
	Displays number of USS telegrams with unidentified start.							
<b>Index:</b>	See r2024							
<b>Note:</b>	Not used on MODBUS.							
r2030[0...1]	<b>USS / MODBUS BCC / CRC error</b>	-	-	-	-	-	U16	3
	Displays number of USS / MODBUS telegrams with BCC / CRC error.							
<b>Index:</b>	See r2024							
<b>Note:</b>	See r2024							
r2031[0...1]	<b>USS / MODBUS length error</b>	-	-	-	-	-	U16	3

Parameter list

7.2 Parameter list

Parameter	Function	Range	Factory default	Can be changed	Scaling	Data set	Data type	Acc. Level
	Displays number of USS / MODBUS telegrams with incorrect length.							
<b>Index:</b>	See r2024							
<b>Note:</b>	See r2024							
P2034	<b>MODBUS parity on RS485</b>	0 - 2	2	U, T	-	-	U16	2
	Parity of MODBUS telegrams on RS485.							
	0	No parity						
	1	Odd parity						
	2	Even parity						
<b>Note:</b>	Also see P2010 for baudrate and P2035 for stop bit settings. You must set P2034 to 0 if P2035=2.							
P2035	<b>MODBUS stop bits on RS485</b>	1 - 2	1	U, T	-	-	U16	2
	Number of stop bits in MODBUS telegrams on RS485.							
	1	1 stop bit						
	2	2 stop bits						
<b>Note:</b>	Also see P2010 for baudrate and P2034 for parity settings. You must set P2035 to 2 if P2034=0.							
r2036.0...15	<b>BO: CtrlWrd1 from USS / MODBUS on RS485</b>	-	-	-	-	-	U16	3
	Displays control word 1 from USS / MODBUS on RS485 (i.e. word 1 within USS / MODBUS = PZD1). See r0054 for the bit field description.							
<b>Dependency:</b>	See P2012							
r2037.0...15	<b>BO: CtrlWrd2 from USS on RS485 (USS)</b>	-	-	-	-	-	U16	3
	Displays control word 2 from USS on RS485 (i.e. word 4 within USS = PZD4). See r0055 for the bit field description.							
<b>Dependency:</b>	See P2012							
<b>Note:</b>	To enable the external fault (r2037 bit 13) facility via USS, the following parameters must be set: <ul style="list-style-type: none"> <li>• P2012 = 4</li> <li>• P2106 = 1</li> </ul>							
r2067.0...12	<b>CO / BO: Digital input values status</b>	-	-	-	-	-	U16	3
	Displays status of digital inputs.							
	<b>Bit</b>	<b>Signal name</b>			<b>1 signal</b>	<b>0 signal</b>		
	00	Digital input 1			Yes	No		
	01	Digital input 2			Yes	No		
	02	Digital input 3			Yes	No		
	03	Digital input 4			Yes	No		
	11	Digital input AI1			Yes	No		
	12	Digital input AI2			Yes	No		
<b>Note:</b>	This is used for BICO connection without software intervention.							
P2100[0...2]	<b>Alarm number selection</b>	0 - 65535	0	T	-	-	U16	3
	Selects up to 3 faults or warnings for non-default reactions.							
<b>Example:</b>	If, for example, an OFF3 is to be carried out instead of an OFF2 for a fault, the fault number has to be entered in P2100 and the desired reaction selected in P2101 (in this case (OFF3) P2101 = 3).							
<b>Index:</b>	[0]	Fault Number 1						
	[1]	Fault Number 2						
	[2]	Fault Number 3						
<b>Note:</b>	All fault codes have a default reaction to OFF2. Some fault codes caused by hardware trips (e.g. overcurrent) cannot be changed from the default reactions.							



Parameter	Function	Range	Factory default	Can be changed	Scaling	Data set	Data type	Acc. Level
P2101[0...2]	<b>Stop reaction value</b>	0 - 3	0	T	-	-	U16	3
	Sets inverter stop reaction values for faults selected by P2100 (alarm number selection). This indexed parameter specifies the special reaction to the faults / warnings defined in P2100 indices 0 to 2.							
	0	No reaction, no display						
	1	OFF1 stop reaction						
	2	OFF2 stop reaction						
	3	OFF3 stop reaction						
<b>Index:</b>	[0]	Stop reaction value 1						
	[1]	Stop reaction value 2						
	[2]	Stop reaction value 3						
<b>Note:</b>	Settings 1 - 3 are only available for fault codes. Index 0 (P2101) refers to fault / warning in index 0 (P2100).							
P2103[0...2]	<b>BI: 1. Faults acknowledgement</b>	0 - 429496729 5	722.2	T	-	CDS	U32	3
	Defines first source of fault acknowledgement.							
<b>Setting:</b>	722.0	Digital input 1 (requires P0701 to be set to 99, BICO)						
	722.1	Digital input 2 (requires P0702 to be set to 99, BICO)						
	722.2	Digital input 3 (requires P0703 to be set to 99, BICO)						
P2104[0...2]	<b>BI: 2. Faults acknowledgement</b>	0 - 429496729 5	0	T	-	CDS	U32	3
	Selects second source of fault acknowledgement.							
<b>Setting:</b>	See P2103							
P2106[0...2]	<b>BI: External fault</b>	0 - 429496729 5	1	T	-	CDS	U32	3
	Selects source of external faults.							
<b>Setting:</b>	See P2103							
r2110[0...3]	<b>CO: Warning number</b>	-	-	-	-	-	U16	2
	Displays warning information. A maximum of 2 active warnings (indices 0 and 1) and 2 historical warnings (indices 2 and 3) may be viewed.							
<b>Index:</b>	[0]	Recent Warnings --, warning 1						
	[1]	Recent Warnings --, warning 2						
	[2]	Recent Warnings -1, warning 3						
	[3]	Recent Warnings -1, warning 4						
<b>Notice:</b>	Indices 0 and 1 are not stored.							
<b>Note:</b>	The LED indicates the warning status in this case. The keypad will flash while a warning is active.							
P2111	<b>Total number of warnings</b>	0 - 4	0	T	-	-	U16	3
	Displays number of warning (up to 4) since last reset. Set to 0 to reset the warning history.							
P2113[0...2]	<b>Disable inverter warnings</b>	0 - 1	0	T	-	-	U16	3

7.2 Parameter list

Parameter	Function	Range	Factory default	Can be changed	Scaling	Data set	Data type	Acc. Level
	Switches off reporting of inverter warnings. Can be used in conjunction with P0503 as an adjunct to keep-running operation.							
	1	Inverter warnings disabled						
	0	Inverter warnings enabled						
<b>Index:</b>	[0]	Inverter data set 0 (DDS0)						
	[1]	Inverter data set 1 (DDS1)						
	[2]	Inverter data set 2 (DDS2)						
<b>Note:</b>	See also P0503							
r2114[0...1]	<b>Run time counter</b>	-	-	-	-	-	U16	3
	<p>Displays run time counter.</p> <p>It is the total time the inverter has been powered up. When power is switched off, the value is saved, and then restored on powerup. The run time counter will be calculate as followed:</p> <p>Multiply the value in r2114[0] by 65536 and then add it to the value in r2114[1]. The resultant answer will be in seconds. This means that r2114[0] is not days. Total powerup time = 65536 * r2114[0] + r2114[1] seconds.</p>							
<b>Example:</b>	<p>If r2114[0] = 1 and r2114[1] = 20864</p> <p>We get 1 * 65536 + 20864 = 86400 seconds which equals 1 day.</p>							
<b>Index:</b>	[0]	System Time, Seconds, Upper Word						
	[1]	System Time, Seconds, Lower Word						
P2115[0...2]	<b>Real time clock</b>	0 - 65535	257	T	-	-	U16	4
	<p>Displays real time.</p> <p>All inverters require an on-board clock function with which fault conditions may be time-stamped and logged. However, they have no battery backed Real Time Clock (RTC). Inverters may support a software driven RTC which requires synchronization with the RTC supplied via a serial interface.</p> <p>The time is stored in a word array parameter P2115. The time will be set by USS Protocol standard "word array parameter write" telegrams. Once the last word is received in index 2, the software will start running the timer itself using internal running 1 millisecond tic. Hence becoming like RTC.</p> <p>If power-cycle takes place, then the real time must be sent again to the inverter.</p> <p>Time is maintained in a word array parameter and encoded as follows - the same format will be used in fault report logs.</p>							
	Index	High Byte (MSB)			Low Byte (LSB)			
	0	Seconds (0 - 59)			Minutes (0 - 59)			
	1	Hours (0 - 23)			Days (1 - 31)			
	2	Month (1 - 12)			Years (00 - 250)			
	The values are in binary form.							
<b>Index:</b>	[0]	Real Time, Seconds + Minutes						
	[1]	Real Time, Hours + Days						
	[2]	Real Time, Month + Year						
P2120	<b>Indication counter</b>	0 - 65535	0	U, T	-	-	U16	4
	Indicates total number of fault / warning events. This parameter is incremented whenever a fault / warning event occurs.							
P2150[0...2]	<b>Hysteresis frequency f_hys [Hz]</b>	0.00 - 10.00	3.00	U, T	-	DDS	Float	3
	Defines hysteresis level applied for comparing frequency and speed to threshold.							

Parameter	Function	Range	Factory default	Can be changed	Scaling	Data set	Data type	Acc. Level
<b>Dependency:</b>	See P1175.							
<b>Note:</b>	If P1175 is set, P2150 is also used to control the Dual Ramp function.							
P2151[0...2]	<b>Cl: Speed setpoint for messages</b>	0 - 429496729 5	1170[0]	U, T	-	DDS	U32	3
	Selects the source of setpoint frequency, actual frequency is compared with this frequency to detect frequency deviation (see monitoring bit r2197.7).							
P2155[0...2]	<b>Threshold frequency f_1 [Hz]</b>	0.00 - 550.00	30.00	U, T	-	DDS	Float	3
	Sets a threshold for comparing actual speed or frequency to threshold values f_1. This threshold controls status bits 4 and 5 in status word 2 (r0053).							
P2156[0...2]	<b>Delay time of threshold freq f_1 [ms]</b>	0 - 10000	10	U, T	-	DDS	U16	3
	Sets delay time prior to threshold frequency f_1 comparison (P2155).							
P2157[0...2]	<b>Threshold frequency f_2 [Hz]</b>	0.00 - 550.00	30.00	U, T	-	DDS	Float	2
	Threshold_2 for comparing speed or frequency to thresholds.							
<b>Dependency:</b>	See P1175.							
<b>Note:</b>	If P1175 is set, P2157 is also used to control the Dual Ramp function.							
P2158[0...2]	<b>Delay time of threshold freq f_2 [ms]</b>	0 - 10000	10	U, T	-	DDS	U16	2
	When comparing speed or frequency to threshold f_2 (P2157) this is the time delay before status bits are cleared.							
P2159[0...2]	<b>Threshold frequency f_3 [Hz]</b>	0.00 - 550.00	30.00	U, T	-	DDS	Float	2
	Threshold_3 for comparing speed or frequency to thresholds.							
<b>Dependency:</b>	See P1175.							
<b>Note:</b>	If P1175 is set, P2159 is also used to control the Dual Ramp function.							
P2160[0...2]	<b>Delay time of threshold freq f_3 [ms]</b>	0 - 10000	10	U, T	-	DDS	U16	2
	When comparing speed or frequency to threshold f_3 (P2159) this is the time delay before status bits are set.							
P2162[0...2]	<b>Hysteresis freq. for over-speed [Hz]</b>	0.00 - 25.00	3.00	U, T	-	DDS	Float	3
	Hysteresis speed (frequency) for overspeed detection. For V/f control modes the hysteresis acts below the maximum frequency.							
P2164[0...2]	<b>Hysteresis frequency deviation [Hz]</b>	0.00 - 10.00	3.00	U, T	-	DDS	Float	3
	Hysteresis frequency for detecting permitted deviation (from setpoint) or frequency or speed. This frequency controls bit 8 in status word 1 (r0052).							
P2166[0...2]	<b>Delay time ramp up completed [ms]</b>	0 - 10000	10	U, T	-	DDS	U16	3
	Delay time for signal that indicates completion of ramp-up.							
P2167[0...2]	<b>Switch-off frequency f_off [Hz]</b>	0.00 - 10.00	1.00	U, T	-	DDS	Float	3

Parameter	Function	Range	Factory default	Can be changed	Scaling	Data set	Data type	Acc. Level
	Defines the threshold of the monitoring function $ f_{act}  > P2167 (f_{off})$ . P2167 influences following functions: <ul style="list-style-type: none"> <li>• If the actual frequency falls below this threshold and the time delay has expired, bit 1 in status word 2 (r0053) is reset.</li> <li>• If an OFF1 or OFF3 was applied and bit 1 is reset the inverter will disable the pulse (OFF2).</li> </ul>							
P2168[0...2]	<b>Delay time T<sub>off</sub> [ms]</b>	0 - 10000	0	U, T	-	DDS	U16	3
	Defines time for which the inverter may operate below switch-off frequency (P2167) before switch off occurs.							
<b>Dependency:</b>	Active if holding brake (P1215) not parameterized.							
P2170[0...2]	<b>Threshold current I<sub>thresh</sub> [%]</b>	0.00 - 400.0	100.0	U, T	-	DDS	Float	3
	Defines threshold current relative to P0305 (rated motor current) to be used in comparisons of I <sub>act</sub> and I <sub>Thresh</sub> . This threshold controls bit 3 in status word 3 (r0053).							
P2171[0...2]	<b>Delay time current [ms]</b>	0 - 10000	10	U, T	-	DDS	U16	3
	Defines delay time prior to activation of current comparison.							
P2172[0...2]	<b>Threshold DC-link voltage [V]</b>	0 - 2000	800	U, T	-	DDS	U16	3
	Defines DC link voltage to be compared to actual voltage. This voltage controls bits 7 and 8 in status word 3 (r0053).							
P2173[0...2]	<b>Delay time DC-link voltage [ms]</b>	0 - 10000	10	U, T	-	DDS	U16	3
	Defines delay time prior to activation of threshold comparison.							
P2177[0...2]	<b>Delay time for motor is blocked [ms]</b>	0 - 10000	10	U, T	-	DDS	U16	3
	Delay time for identifying that the motor is blocked.							
P2179	<b>Current limit for no load identified [%]</b>	0.00 - 10.0	3.0	U, T	-	-	Float	3
	Threshold current for A922 (no load applied to inverter) relative to P0305 (rated motor current).							
<b>Notice:</b>	If a motor setpoint cannot be entered and the current limit (P2179) is not exceeded, warning A922 (no load applied) is issued when delay time (P2180) expires.							
<b>Note:</b>	It may be that the motor is not connected or a phase could be missing.							
P2180	<b>Delay time for no-load detection [ms]</b>	0 - 10000	2000	U, T	-	-	U16	3
	Delay time for detecting a missing output load.							
P2181[0...2]	<b>Load monitoring mode</b>	0 - 6	0	T	-	DDS	U16	3

Parameter	Function	Range	Factory default	Can be changed	Scaling	Data set	Data type	Acc. Level
	<p>Sets load monitoring mode.</p> <p>This function allows monitoring of mechanical failure of the inverter train, e.g. a broken inverter belt. It can also detect conditions which cause an overload, such as a jam. P2182 -P2190 are set to the following values when this parameter is changed from 0.</p> <p>P2182 = P1080 (Fmin)  P2183 = P1082 (Fmax) * 0.8  P2184 = P1082 (Fmax)  P2185 = r0333 (rated motor torque) * 1.1  P2186 = 0  P2187 = r0333 (rated motor torque) * 1.1  P2188 = 0  P2189 = r0333 (rated motor torque) * 1.1  P2190 = r0333 (rated motor torque) / 2</p> <p>This is achieved by comparing the actual frequency / torque curve with a programmed envelope (see P2182 - P2190). If the curve falls outside the envelope, a warning A952 or trip F452 is generated.</p>							
	0	Load monitoring disabled						
	1	Warning: Low torque / frequency						
	2	Warning: High torque / frequency						
	3	Warning: High / low torque / frequency						
	4	Trip: Low torque / frequency						
	5	Trip: High torque / frequency						
	6	Trip: High / low torque / frequency						
P2182[0...2]	<b>Load monitoring threshold frequency 1 [Hz]</b>	0.00 - 550.00	5.00	U, T	-	DDS	Float	3
	Sets the lower frequency threshold f_1 for defining the area where the load monitoring is effective. The frequency torque envelope is defined by 9 parameters - 3 are frequency parameters (P2182 - P2184), and the other 6 define the low and high torque limits (P2185 - P2190) for each frequency.							
<b>Dependency:</b>	See P2181 for calculated default value.							
<b>Note:</b>	Below the threshold in P2182 and above the threshold in P2184, the load monitoring mode is not active. In this case the values for normal operation with the torque limits given in P1521 and P1520 are valid.							
P2183[0...2]	<b>Load monitoring threshold frequency 2 [Hz]</b>	0.00 - 550.00	30.00	U, T	-	DDS	Float	3
	Sets the frequency threshold f_2 for defining the envelope in which the torque values are valid. See P2182.							
<b>Dependency:</b>	See P2181 for calculated default value.							
P2184[0...2]	<b>Load monitoring threshold frequency 3 [Hz]</b>	0.00 - 550.00	50.00	U, T	-	DDS	Float	3
	Sets the upper frequency threshold f_3 for defining the area where the load monitoring is effective. See P2182.							
<b>Dependency:</b>	See P2181 for calculated default value.							
P2185[0...2]	<b>Upper torque threshold 1 [Nm]</b>	0.0 - 99999.0	Value in r0333	U, T	-	DDS	Float	3
	Upper limit threshold value 1 for comparing actual torque.							

7.2 Parameter list

Parameter	Function	Range	Factory default	Can be changed	Scaling	Data set	Data type	Acc. Level
<b>Dependency:</b>	This parameter is influenced by automatic calculations defined by P0340. See P2181 for calculated default value.							
<b>Note:</b>	The factory setting depends on rating data of Power Module and Motor.							
P2186[0...2]	<b>Lower torque threshold 1 [Nm]</b>	0.0 - 99999.0	0.0	U, T	-	DDS	Float	3
	Lower limit threshold value 1 for comparing actual torque.							
<b>Dependency:</b>	See P2181 for calculated default value.							
P2187[0...2]	<b>Upper torque threshold 2 [Nm]</b>	0.0 - 99999.0	Value in r0333	U, T	-	DDS	Float	3
	Upper limit threshold value 2 for comparing actual torque.							
<b>Dependency:</b>	This parameter is influenced by automatic calculations defined by P0340. See P2181 for calculated default value.							
<b>Note:</b>	See P2185							
P2188[0...2]	<b>Lower torque threshold 2 [Nm]</b>	0.0 - 99999.0	0.0	U, T	-	DDS	Float	3
	Lower limit threshold value 2 for comparing actual torque.							
<b>Dependency:</b>	See P2181 for calculated default value.							
P2189[0...2]	<b>Upper torque threshold 3 [Nm]</b>	0.0 - 99999.0	Value in r0333	U, T	-	DDS	Float	3
	Upper limit threshold value 3 for comparing actual torque.							
<b>Dependency:</b>	This parameter is influenced by automatic calculations defined by P0340. See P2181 for calculated default value.							
<b>Note:</b>	See P2185							
P2190[0...2]	<b>Lower torque threshold 3 [Nm]</b>	0.0 - 99999.0	0.0	U, T	-	DDS	Float	3
	Lower limit threshold value 3 for comparing actual torque.							
<b>Dependency:</b>	See P2181 for calculated default value.							
P2192[0...2]	<b>Load monitoring delay time [s]</b>	0 - 65	10	U, T	-	DDS	U16	3
	P2192 defines a delay before warning / trip becomes active. - It is used to eliminate events caused by transient conditions. - It is used for both methods of fault detection.							
r2197.0...12	<b>CO / BO: Monitoring word 1</b>	-	-	-	-	-	U16	3
	Monitoring word 1 which indicates the state of monitor functions. Each bit represents one monitor function.							
	<b>Bit</b>	<b>Signal name</b>			<b>1 signal</b>	<b>0 signal</b>		
	00	f_act  <= P1080 (f_min)			Yes	No		
	01	f_act  <= P2155 (f_1)			Yes	No		
	02	f_act  > P2155 (f_1)			Yes	No		
	03	f_act >= zero			Yes	No		
	04	f_act >= setp. (f_set)			Yes	No		
	05	f_act  <= P2167 (f_off)			Yes	No		
	06	f_act  >= P1082 (f_max)			Yes	No		

Parameter	Function	Range	Factory default	Can be changed	Scaling	Data set	Data type	Acc. Level
	07	f_act == setp. (f_set)			Yes		No	
	08	Act. current  r0027  >= P2170			Yes		No	
	09	Act. unfilt. Vdc < P2172			Yes		No	
	10	Act. unfilt. Vdc > P2172			Yes		No	
	11	Output load is not present			Yes		No	
	12	f_act  > P1082 with delay			Yes		No	
r2198.0...12	<b>CO / BO: Monitoring word 2</b>	-	-	-	-	-	U16	3
	Monitoring word 2 which indicates the state of monitor functions. Each bit represents one monitor function.							
	<b>Bit</b>	<b>Signal name</b>			<b>1 signal</b>	<b>0 signal</b>		
	00	f_act  <= P2157 (f_2)			Yes	No		
	01	f_act  > P2157 (f_2)			Yes	No		
	02	f_act  <= P2159 (f_3)			Yes	No		
	03	f_act  > P2159 (f_3)			Yes	No		
	04	f_set  < P2161 (f_min_set)			Yes	No		
	05	f_set > 0			Yes	No		
	06	Motor blocked			Yes	No		
	07	Motor pulled out			Yes	No		
	08	I_act  r0068  < P2170			Yes	No		
	09	m_act  > P2174 & setpoint reached			Yes	No		
	10	m_act  > P2174			Yes	No		
	11	Load monitoring signals an alarm			Yes	No		
	12	Load monitoring signals a fault			Yes	No		
P2200[0...2]	<b>BI: Enable PID controller</b>	0 - 429496729 5	0	U, T	-	CDS	U32	2
	Allows user to enable / disable the PID controller. Setting to 1 enables the PID closed-loop controller.							
<b>Dependency:</b>	Setting 1 automatically disables normal ramp times set in P1120 and P1121 and the normal frequency setpoints. Following an OFF1 or OFF3 command, however, the inverter frequency will ramp down to zero using the ramp time set in P1121 (P1135 for OFF3).							
<b>Notice:</b>	The minimum and maximum motor frequencies (P1080 and P1082) as well as the skip frequencies (P1091 to P1094) remain active on the inverter output. However, enabling skip frequencies with PID control can produce instabilities.							
<b>Note:</b>	The PID setpoint source is selected using P2253. The PID setpoint and the PID feedback signal are interpreted as [%] values (not [Hz]). The output of the PID controller is displayed as [%] and then normalized into [Hz] through P2000 (reference frequency) when PID is enabled. The reverse command is not active when PID is active. Attention: P2200 and P2803 are locked parameter against each other. PID and FFB of the same data set cannot be active at same time.							
P2201[0...2]	<b>Fixed PID setpoint 1 [%]</b>	-200.00 - 200.00	10.00	U, T	-	DDS	Float	2

7.2 Parameter list

Parameter	Function	Range	Factory default	Can be changed	Scaling	Data set	Data type	Acc. Level
	Defines fixed PID setpoint 1. There are 2 types of fixed frequencies: 1. Direct selection (P2216 = 1): – In this mode of operation 1 Fixed Frequency selector (P2220 to P2223) selects 1 fixed frequency. – If several inputs are active together, the selected frequencies are summed. E.g.: PID-FF1 + PID-FF2 + PID-FF3 + PID-FF4. 2. Binary coded selection (P2216 = 2): – Up to 16 different fixed frequency values can be selected using this method.							
<b>Dependency:</b>	P2200 = 1 required in user access level 2 to enable setpoint source.							
<b>Note:</b>	You may mix different types of frequencies; however, remember that they will be summed if selected together. P2201 = 100 % corresponds to 4000 hex.							
P2202[0...2]	<b>Fixed PID setpoint 2 [%]</b>	-200.00 - 200.00	20.00	U, T	-	DDS	Float	2
	Defines fixed PID setpoint 2.							
<b>Note:</b>	See P2201							
P2203[0...2]	<b>Fixed PID setpoint 3 [%]</b>	-200.00 - 200.00	50.00	U, T	-	DDS	Float	2
	Defines fixed PID setpoint 3.							
<b>Note:</b>	See P2201							
P2204[0...2]	<b>Fixed PID setpoint 4 [%]</b>	-200.00 - 200.00	100.00	U, T	-	DDS	Float	2
	Defines fixed PID setpoint 4.							
<b>Note:</b>	See P2201							
P2205[0...2]	<b>Fixed PID setpoint 5 [%]</b>	-200.00 - 200.00	0.00	U, T	-	DDS	Float	2
	Defines fixed PID setpoint 5.							
<b>Note:</b>	See P2201							
P2206[0...2]	<b>Fixed PID setpoint 6 [%]</b>	-200.00 - 200.00	0.00	U, T	-	DDS	Float	2
	Defines fixed PID setpoint 6.							
<b>Note:</b>	See P2201							
P2207[0...2]	<b>Fixed PID setpoint 7 [%]</b>	-200.00 - 200.00	0.00	U, T	-	DDS	Float	2
	Defines fixed PID setpoint 7.							
<b>Note:</b>	See P2201							
P2208[0...2]	<b>Fixed PID setpoint 8 [%]</b>	-200.00 - 200.00	0.00	U, T	-	DDS	Float	2
	Defines fixed PID setpoint 8.							
<b>Note:</b>	See P2201							
P2209[0...2]	<b>Fixed PID setpoint 9 [%]</b>	-200.00 - 200.00	0.00	U, T	-	DDS	Float	2
	Defines fixed PID setpoint 9.							
<b>Note:</b>	See P2201							



Parameter	Function	Range	Factory default	Can be changed	Scaling	Data set	Data type	Acc. Level
P2210[0...2]	<b>Fixed PID setpoint 10 [%]</b>	-200.00 - 200.00	0.00	U, T	-	DDS	Float	2
	Defines fixed PID setpoint 10.							
<b>Note:</b>	See P2201							
P2211[0...2]	<b>Fixed PID setpoint 11 [%]</b>	-200.00 - 200.00	0.00	U, T	-	DDS	Float	2
	Defines fixed PID setpoint 11.							
<b>Note:</b>	See P2201							
P2212[0...2]	<b>Fixed PID setpoint 12 [%]</b>	-200.00 - 200.00	0.00	U, T	-	DDS	Float	2
	Defines fixed PID setpoint 12.							
<b>Note:</b>	See P2201							
P2213[0...2]	<b>Fixed PID setpoint 13 [%]</b>	-200.00 - 200.00	0.00	U, T	-	DDS	Float	2
	Defines fixed PID setpoint 13.							
<b>Note:</b>	See P2201							
P2214[0...2]	<b>Fixed PID setpoint 14 [%]</b>	-200.00 - 200.00	0.00	U, T	-	DDS	Float	2
	Defines fixed PID setpoint 14.							
<b>Note:</b>	See P2201							
P2215[0...2]	<b>Fixed PID setpoint 15 [%]</b>	-200.00 - 200.00	0.00	U, T	-	DDS	Float	2
	Defines fixed PID setpoint 15.							
<b>Note:</b>	See P2201							
P2216[0...2]	<b>Fixed PID setpoint mode</b>	1 - 2	1	T	-	DDS	U16	2
	Fixed frequencies for PID setpoint can be selected in two different modes. P2216 defines the mode.							
	1	Direct selection						
	2	Binary selection						
P2220[0...2]	<b>BI: Fixed PID setpoint select bit 0</b>	0 - 429496729 5	722.3	T	-	CDS	U32	3
	Defines command source of fixed PID setpoint selection bit 0.							
P2221[0...2]	<b>BI: Fixed PID setpoint select bit 1</b>	0 - 429496729 5	722.4	T	-	CDS	U32	3
	Defines command source of fixed PID setpoint selection bit 1.							
P2222[0...2]	<b>BI: Fixed PID setpoint select bit 2</b>	0 - 429496729 5	722.5	T	-	CDS	U32	3
	Defines command source of fixed PID setpoint selection bit 2.							
P2223[0...2]	<b>BI: Fixed PID setpoint select bit 3</b>	0 - 429496729 5	722.6	T	-	CDS	U32	3
	Defines command source of fixed PID setpoint selection bit 3.							

Parameter list

7.2 Parameter list

Parameter	Function	Range	Factory default	Can be changed	Scaling	Data set	Data type	Acc. Level
r2224	<b>CO: Actual fixed PID setpoint [%]</b>	-	-	-	-	-	Float	2
	Displays total output of PID fixed setpoint selection.							
<b>Note:</b>	r2224 = 100 % corresponds to 4000 hex.							
r2225.0	<b>BO: PID fixed frequency status</b>	-	-	-	-	-	U16	3
	Displays the status of PID fixed frequencies.							
	<b>Bit</b>	<b>Signal name</b>	<b>1 signal</b>		<b>0 signal</b>			
	00	Status of FF	Yes		No			
P2231[0...2]	<b>PID-MOP mode</b>	0 - 3	0	U, T	-	DDS	U16	2
	PID-MOP mode specification							
	<b>Bit</b>	<b>Signal name</b>	<b>1 signal</b>		<b>0 signal</b>			
	00	Setpoint store active	Yes		No			
	01	No On-state for MOP necessary	Yes		No			
<b>Note:</b>	Defines the operation mode of the motorized potentiometer. See P2240.							
P2232	<b>Inhibit reverse direction of PID-MOP</b>	0 - 1	1	T	-	-	U16	2
	Inhibits reverse setpoint selection of the PID-MOP.							
	0	Reverse direction is allowed						
	1	Reverse direction inhibited						
<b>Note:</b>	Setting 0 enables a change of motor direction using the motor potentiometer setpoint (increase / decrease frequency).							
P2235[0...2]	<b>BI: Enable PID-MOP (UP-cmd)</b>	0 - 429496729 5	0	T	-	CDS	U32	3
	Defines source of UP command.							
<b>Dependency:</b>	To change setpoint: - Configure a digital input as source - Use UP / DOWN key on operator panel.							
<b>Notice:</b>	If this command is enabled by short pulses of less than 1 second, the frequency is changed in steps of 0.2 % (P0310). When the signal is enabled longer than 1 second the ramp generator accelerates with the rate of P2247.							
P2236[0...2]	<b>BI: Enable PID-MOP (DOWN-cmd)</b>	0 - 429496729 5	0	T	-	CDS	U32	3
	Defines source of DOWN command.							
<b>Dependency:</b>	See P2235							
<b>Notice:</b>	If this command is enabled by short pulses of less than 1 second, the frequency is changed in steps of 0.2 % (P0310). When the signal is enabled longer than 1 second the ramp generator decelerates with the rate of P2248.							
P2240[0...2]	<b>Setpoint of PID-MOP [%]</b>	-200.00 - 200.00	10.00	U, T	-	DDS	Float	2
	Setpoint of the motor potentiometer. Allows user to set a digital PID setpoint in [%].							

Parameter	Function	Range	Factory default	Can be changed	Scaling	Data set	Data type	Acc. Level
<b>Note:</b>	<p>P2240 = 100 % corresponds to 4000 hex.</p> <p>The start value gets active (for the MOP output) only at the start of the MOP. P2231 influences the start value behavior as follows:</p> <ul style="list-style-type: none"> <li>• P2231 = 0: P2240 gets immediately active in the OFF-state and when changed in the ON-state, it gets active after the next OFF and ON cycle.</li> <li>• P2231 = 1: The last MOP output before stop is stored as starting value, since storing is selected, so a change of P2240 while in ON-state has no effect. In OFF-state P2240 can be changed.</li> <li>• P2231 = 2: The MOP is active every time, so the change of P2240 affects after the next power-cycle or a change of P2231 to 0.</li> <li>• P2231 = 3: The last MOP output before power down is stored as starting value, since the MOP is active independent from the ON-command, a change of P2240 has only effect in the case of a change of P2231.</li> </ul>							
P2241[0...2]	<b>BI: PID-MOP select setpoint auto / manu</b>	0 - 429496729 5	0	T	-	CDS	U32	3
	<p>Sets the signal source to change over from manual to automatic mode. If using the motorized potentiometer in the manual mode the setpoint is changed using two signals for up and down, e.g. P2235 and P2236. If using the automatic mode the setpoint must be interconnected via the connector input (P2242).</p> <p>0: manually 1: automatically</p>							
<b>Notice:</b>	Refer to: P2235, P1036, P2242							
P2242[0...2]	<b>CI: PID-MOP auto setpoint</b>	0 - 429496729 5	0	T	-	CDS	U32	3
	Sets the signal source for the setpoint of the motorized potentiometer if automatic mode P2241 is selected.							
<b>Notice:</b>	Refer to: P2241							
P2243[0...2]	<b>BI: PID-MOP accept rampgenerator setpoint</b>	0 - 429496729 5	0	T	-	CDS	U32	3
	Sets the signal source for the setting command to accept the setting value for the motorized potentiometer. The value becomes effective for a 0/1 edge of the setting command.							
<b>Notice:</b>	Refer to: P2244							
P2244[0...2]	<b>CI: PID-MOP rampgenerator setpoint</b>	0 - 429496729 5	0	T	-	CDS	U32	3
	Sets the signal source for the setpoint value for the MOP. The value becomes effective for a 0/1 edge of the setting command.							
<b>Notice:</b>	Refer to: P2243							
r2245	<b>CO: PID-MOP input frequency of the RFG [%]</b>	-	-	-	-	-	Float	3

Parameter list

7.2 Parameter list

Parameter	Function	Range	Factory default	Can be changed	Scaling	Data set	Data type	Acc. Level
	Displays the motorized potentiometer setpoint before it passed the PID-MOP RFG.							
P2247[0...2]	<b>PID-MOP ramp-up time of the RFG [s]</b>	0.00 - 1000.0	10.00	U, T	-	DDS	Float	2
	Sets the ramp-up time for the internal PID-MOP ramp-function generator. The setpoint is changed from zero up to limit defined in P1082 within this time.							
<b>Notice:</b>	Refer to: P2248, P1082							
P2248[0...2]	<b>PID-MOP ramp-down time of the RFG [s]</b>	0.00 - 1000.0	10.00	U, T	-	DDS	Float	2
	Sets the ramp-down time for the internal PID-MOP ramp-function generator. The setpoint is changed from limit defined in P1082 down to zero within this time.							
<b>Notice:</b>	Refer to: P2247, P1082							
r2250	<b>CO: Output setpoint of PID-MOP [%]</b>	-	-	-	PERCENT	-	Float	2
	Displays output setpoint of motor potentiometer.							
P2251	<b>PID mode</b>	0 - 1	0	T	-	-	U16	3
	Enables function of PID controller.							
	0	PID as setpoint						
	1	PID as trim						
<b>Dependency:</b>	Active when PID loop is enabled (see P2200).							
P2253[0...2]	<b>CI: PID setpoint</b>	0 - 429496729 5	0	U, T	4000H	CDS	U32	2
	Defines setpoint source for PID setpoint input. This parameter allows the user to select the source of the PID setpoint. Normally, a digital setpoint is selected either using a fixed PID setpoint or an active setpoint.							
P2254[0...2]	<b>CI: PID trim source</b>	0 - 429496729 5	0	U, T	4000H	CDS	U32	3
	Selects trim source for PID setpoint. This signal is multiplied by the trim gain and added to the PID setpoint.							
<b>Setting:</b>	755	Analog input 1						
	2224	Fixed PI setpoint (see P2201 to P2207)						
	2250	Active PI setpoint (see P2240)						
P2255	<b>PID setpoint gain factor</b>	0.00 - 100.00	100.00	U, T	-	-	Float	3
	Gain factor for PID setpoint. The PID setpoint input is multiplied by this gain factor to produce a suitable ratio between setpoint and trim.							
P2256	<b>PID trim gain factor</b>	0.00 - 100.00	100.00	U, T	-	-	Float	3
	Gain factor for PID trim. This gain factor scales the trim signal, which is added to the main PID setpoint.							
P2257	<b>Ramp-up time for PID setpoint [s]</b>	0.00 - 650.00	1.00	U, T	-	-	Float	2
	Sets the ramp-up time for the PID setpoint.							
<b>Dependency:</b>	P2200 = 1 (PID control is enabled) disable normal ramp-up time (P1120). PID ramp time effective only on PID setpoint and only active when PID setpoint is changed or when RUN command is given (when PID setpoint uses this ramp to reach its value from 0 %).							

Parameter	Function	Range	Factory default	Can be changed	Scaling	Data set	Data type	Acc. Level
<b>Notice:</b>	Setting the ramp-up time too short may cause the inverter to trip, on overcurrent for example.							
P2258	<b>Ramp-down time for PID setpoint [s]</b>	0.00 - 650.00	1.00	U, T	-	-	Float	2
	Sets ramp-down time for PID setpoint.							
<b>Dependency:</b>	P2200 = 1 (PID control is enabled) disables normal ramp-down time (P1121). PID setpoint ramp effective only on PID setpoint changes. P1121 (ramp-down time) and P1135 (OFF3 ramp-down time) define the ramp times used after OFF1 and OFF3 respectively.							
<b>Notice:</b>	Setting the ramp-down time too short can cause the inverter to trip on overvoltage F2 / overcurrent F1.							
r2260	<b>CO: PID setpoint after PID-RFG [%]</b>	-	-	-	-	-	Float	2
	Displays total active PID setpoint after PID-RFG.							
<b>Note:</b>	r2260 = 100 % corresponds to 4000 hex.							
P2261	<b>PID setpoint filter time constant [s]</b>	0.00 - 60.00	0.00	U, T	-	-	Float	3
	Sets a time constant for smoothing the PID setpoint.							
<b>Note:</b>	P2261 = 0 = no smoothing.							
r2262	<b>CO: Filtered PID setpoint after RFG [%]</b>	-	-	-	-	-	Float	3
	Displays filtered PID setpoint after PID-RFG. r2262 is the result of the value in r2260, filtered with PT1-Filter and the time constant given in P2261.							
<b>Note:</b>	r2262 = 100 % corresponds to 4000 hex.							
P2263	<b>PID controller type</b>	0 - 1	0	T	-	-	U16	3
	Sets the PID controller type.							
	0	D component on feedback signal						
	1	D component on error signal						
P2264[0...2]	<b>CI: PID feedback</b>	0 - 429496729 5	0	U, T	4000H	CDS	U32	2
	Selects the source of the PID feedback signal.							
<b>Setting:</b>	See P2254							
<b>Note:</b>	When analog input is selected, offset and gain can be implemented using P0756 to P0760 (analog input scaling).							
P2265	<b>PID feedback filter time constant [s]</b>	0.00 - 60.00	0.00	U, T	-	-	Float	2
	Defines time constant for PID feedback filter.							
r2266	<b>CO: PID filtered feedback [%]</b>	-	-	-	-	-	Float	2
	Displays PID feedback signal.							
<b>Note:</b>	r2266 = 100 % corresponds to 4000 hex.							
P2267	<b>Maximum value for PID feedback [%]</b>	-200.00 - 200.00	100.00	U, T	-	-	Float	3
	Sets the upper limit for the value of the feedback signal.							
<b>Notice:</b>	When PID is enabled (P2200 = 1) and the signal rises above this value, the inverter will trip with F222.							
<b>Note:</b>	P2267 = 100 % corresponds to 4000 hex.							

Parameter list

7.2 Parameter list

Parameter	Function	Range	Factory default	Can be changed	Scaling	Data set	Data type	Acc. Level
P2268	<b>Minimum value for PID feedback [%]</b>	-200.00 - 200.00	0.00	U, T	-	-	Float	3
	Sets lower limit for value of feedback signal.							
<b>Notice:</b>	When PID is enabled (P2200 = 1) and the signal drops below this value, the inverter will trip with F221.							
<b>Note:</b>	P2268 = 100 % corresponds to 4000 hex.							
P2269	<b>Gain applied to PID feedback</b>	0.00 - 500.00	100.00	U, T	-	-	Float	3
	Allows the user to scale the PID feedback as a percentage value. A gain of 100.0 % means that feedback signal has not changed from its default value.							
P2270	<b>PID feedback function selector</b>	0 - 3	0	U, T	-	-	U16	3
	Applies mathematical functions to the PID feedback signal, allowing multiplication of the result by P2269.							
	0	Disabled						
	1	Square root (root(x))						
	2	Square (x*x)						
	3	Cube (x*x*x)						
P2271	<b>PID transducer type</b>	0 - 1	0	U, T	-	-	U16	2
	Allows the user to select the transducer type for the PID feedback signal.							
	0	Disabled						
	1	Inversion of PID feedback signal						
<b>Notice:</b>	It is essential that you select the correct transducer type. If you are unsure whether 0 or 1 is applicable, you can determine the correct type as follows: 1. Disable the PID function (P2200 = 0). 2. Increase the motor frequency while measuring the feedback signal. 3. If the feedback signal increases with an increase in motor frequency, the PID transducer type should be 0. 4. If the feedback signal decreases with an increase in motor frequency the PID transducer type should be set to 1.							
r2272	<b>CO: PID scaled feedback [%]</b>	-	-	-	-	-	Float	2
	Displays PID scaled feedback signal.							
<b>Note:</b>	r2272 = 100 % corresponds to 4000 hex.							
r2273	<b>CO: PID error [%]</b>	-	-	-	-	-	Float	2
	Displays PID error (difference) signal between setpoint and feedback signals.							
<b>Note:</b>	r2273 = 100 % corresponds to 4000 hex.							
P2274	<b>PID derivative time [s]</b>	0.000 - 60.000	0.000	U, T	-	-	Float	2
	Sets PID derivative time. P2274 = 0: The derivative term does not have any effect (it applies a gain of 1).							

Parameter	Function	Range	Factory default	Can be changed	Scaling	Data set	Data type	Acc. Level
P2280	<b>PID proportional gain</b>	0.000 - 65.000	3.000	U, T	-	-	Float	2
	Allows user to set proportional gain for PID controller. The PID controller is implemented using the standard model. For best results, enable both P and I terms.							
<b>Dependency:</b>	P2280 = 0 (P term of PID = 0): The I term acts on the square of the error signal. P2285 = 0 (I term of PID = 0): PID controller acts as a P or PD controller respectively.							
<b>Note:</b>	If the system is prone to sudden step changes in the feedback signal, P term should normally be set to a small value (0.5) with a faster I term for optimum performance.							
P2285	<b>PID integral time [s]</b>	0.000 - 60.000	0.000	U, T	-	-	Float	2
	Sets integral time constant for PID controller.							
<b>Note:</b>	See P2280							
P2291	<b>PID output upper limit [%]</b>	-200.00 - 200.00	100.00	U, T	-	-	Float	2
	Sets upper limit for PID controller output							
<b>Dependency:</b>	If f_max (P1082) is greater than P2000 (reference frequency), either P2000 or P2291 (PID output upper limit) must be changed to achieve f_max.							
<b>Note:</b>	P2291 = 100 % corresponds to 4000 hex (as defined by P2000 (reference frequency)).							
P2292	<b>PID output lower limit [%]</b>	-200.00 - 200.00	0.00	U, T	-	-	Float	2
	Sets lower limit for the PID controller output.							
<b>Dependency:</b>	A negative value allows bipolar operation of PID controller.							
<b>Note:</b>	P2292 = 100 % corresponds to 4000 hex.							
P2293	<b>Ramp-up / -down time of PID limit [s]</b>	0.00 - 100.00	1.00	U, T	-	-	Float	3
	Sets maximum ramp rate on output of PID. When PI is enabled, the output limits are ramped up from 0 to the limits set in P2291 (PID output upper limit) and P2292 (PID output lower limit). Limits prevent large step changes appearing on the output of the PID when the inverter is started. Once the limits have been reached, the PID controller output is instantaneous. These ramp times are used whenever a RUN command is issued.							
<b>Note:</b>	If an OFF1 or OFF 3 are issued, the inverter output frequency ramps down as set in P1121 (ramp-down time) or P1135 (OFF3 ramp-down time).							
r2294	<b>CO: Actual PID output [%]</b>	-	-	-	-	-	Float	2
	Displays PID output.							
<b>Note:</b>	r2294 = 100 % corresponds to 4000 hex.							
P2295	<b>Gain applied to PID output</b>	-100.00 - 100.00	100.00	U, T	-	-	Float	3
	Allows the user to scale the PID output as a percentage value. A gain of 100.0 % means that output signal has not changed from its default value.							
<b>Note:</b>	The ramp rate applied by the PID controller is clamped to a rate of 0.1s / 100% to protect the inverter.							

7.2 Parameter list

Parameter	Function	Range	Factory default	Can be changed	Scaling	Data set	Data type	Acc. Level
P2350	<b>PID autotune enable</b>	0 - 4	0	U, T	-	-	U16	2
	Enables autotune function of PID controller.							
	0	PID autotuning disabled						
	1	PID autotuning via Ziegler Nichols (ZN) standard						
	2	PID autotuning as 1 plus some overshoot (O/S)						
	3	PID autotuning as 2 little or no overshoot (O/S)						
	4	PID autotuning PI only, quarter damped response						
<b>Dependency:</b>	Active when PID loop is enabled (see P2200).							
<b>Note:</b>	<ul style="list-style-type: none"> <li>• P2350 = 1 This is the standard Ziegler Nichols (ZN) tuning which should be a quarter damped response to a step.</li> <li>• P2350 = 2 This tuning will give some overshoot (O/S) but should be faster than option 1.</li> <li>• P2350 = 3 This tuning should give little or no overshoot but will not be as fast as option 2.</li> <li>• P2350 = 4 This tuning only changes values of P and I and should be a quarter damped response.</li> </ul> <p>The option to be selected depends on the application but broadly speaking option 1 will give a good response, whereas if a faster response is desired option 2 should be selected.</p> <p>If no overshoot is desired then option 3 is the choice. For cases where no D term is wanted then option 4 can be selected.</p> <p>The tuning procedure is the same for all options. It is just the calculation of P and D values that is different. After autotune this parameter is set to zero (autotune completed).</p>							
P2354	<b>PID tuning timeout length [s]</b>	60 - 65000	240	U, T	-	-	U16	3
	This parameter determines the time that the autotuning code will wait before aborting a tuning run if no oscillation has been obtained.							
P2355	<b>PID tuning offset [%]</b>	0.00 - 20.00	5.00	U, T	-	-	Float	3
	Sets applied offset and deviation for PID autotuning.							
<b>Note:</b>	This can be varied depending on plant conditions e.g. a very long system time constant might require a larger value.							
P2360[0...2]	<b>Enable cavitation protection</b>	0 - 2	0	U, T	-	DDS	U16	2



Parameter	Function	Range	Factory default	Can be changed	Scaling	Data set	Data type	Acc. Level
	<p>Cavitation protection enabled. Will generate a fault / warning when cavitation conditions are deemed to be present.</p> <p><b>Cavitation Protection Logic Diagram</b></p>							
	0	Disable						
	1	Fault						
	2	Warn						
P2361[0...2]	<b>Cavitation threshold [%]</b>	0.00 - 200.00	40.00	U, T	-	DDS	Float	2
	Feedback threshold over which a fault / warning is triggered, as a percentage (%).							
P2362[0...2]	<b>Cavitation protection time [s]</b>	0 - 65000	30	U, T	-	DDS	U16	2
	The time for which cavitation conditions have to be present before a fault / warning is triggered.							
P2365[0...2]	<b>Hibernation enable / disable</b>	0 - 1	0	U, T	-	DDS	U16	2
	Enable or disable the hibernation functionality. 0 = disabled 1 = enabled							
P2366[0...2]	<b>Delay before stopping motor [s]</b>	0 - 254	5	U, T	-	DDS	U16	3

7.2 Parameter list

Parameter	Function	Range	Factory default	Can be changed	Scaling	Data set	Data type	Acc. Level
	With hibernation enabled. If the frequency demand drops below the threshold there is a delay of P2366 seconds before the inverter is stopped.							
P2367[0...2]	<b>Delay before starting motor [s]</b>	0 - 254	2	U, T	-	DDS	U16	3
	With hibernation enabled. If pulses have been disabled by the unit going into hibernation, and the frequency demand has increased to above the hibernation threshold, there will be a delay of P2367 seconds before the inverter restarts.							
P2370[0...2]	<b>Motor staging stop mode</b>	0 - 1	0	T	-	DDS	U16	3
	Selects stop mode for external motors when motor staging is in use.							
	0	Normal stop						
	1	Sequence stop						
P2371[0...2]	<b>Motor staging configuration</b>	0 - 3	0	T	-	DDS	U16	3
	Selects configuration of external motors (M1, M2) used for motor staging feature.							
	0	Motor staging disabled						
	1	M1 = 1 x MV, M2 = Not fitted						
	2	M1 = 1 x MV, M2 = 1 x MV						
	3	M1 = 1 x MV, M2 = 2 x MV						
<b>Caution:</b>	For this kind of motor application it is mandatory to disable negative frequency setpoint!							
<b>Note:</b>	<p>Motor staging allows the control of up to 2 additional staged pumps or fans, based on a PID control system.</p> <p>The complete system consists of one pump controlled by the inverter with up to 2 further pumps / fans controlled from contactors or motor starters.</p> <p>The contactors or motor starter are controlled by outputs from the inverter.</p> <p>The diagram below shows a typical pumping system.</p> <p>A similar system could be set up using fans and air ducts, instead of pumps and pipes.</p> <p>Mains</p>							

Parameter	Function	Range	Factory default	Can be changed	Scaling	Data set	Data type	Acc. Level																																																																																
	<p>By default the motor states are controlled from digital outputs.</p> <p>In the text below, the following terminology will be used:</p> <p>MV - Variable speed (Inverter controlled motor)</p> <p>M1 - Motor switched with digital output 1</p> <p>M2 - Motor switched with digital output 2</p> <p>Staging: The process of starting one of the fixed speed motors.</p> <p>De-staging: The process of stopping one of the fixed speed motors.</p> <p>When the inverter is running at maximum frequency, and the PID feedback indicates that a higher speed is required, the inverter switches on (stages) one of the digital output controlled motors M1 and M2.</p> <p>At the same time, to keep the controlled variable as constant as possible, the inverter must ramp down to minimum frequency.</p> <p>Therefore, during the staging process, PID control must be suspended (see P2378 and diagram below)</p> <p><b>Staging of external motors (M1, M2)</b></p> <div style="text-align: right; margin-right: 20px;">Switch-on</div> <table style="margin-left: auto; margin-right: auto;"> <tr> <td>P2371 =</td> <td>0</td> <td>-</td> <td>-</td> <td>-</td> <td>-</td> <td>-</td> <td>-</td> <td>-</td> <td>-</td> </tr> <tr> <td>1</td> <td>-</td> <td>M1</td> <td>M1</td> <td>M1</td> <td>M1</td> <td>M1</td> <td>M1</td> <td>M1</td> <td>M1</td> </tr> <tr> <td>2</td> <td>-</td> <td>M1</td> <td>M1+M2</td> <td>M1+M2</td> <td>M1+M2</td> <td>M1+M2</td> <td>M1+M2</td> <td>M1+M2</td> <td>M1+M2</td> </tr> <tr> <td>3</td> <td>-</td> <td>M1</td> <td>M2</td> <td>M1+M2</td> <td>M1+M2</td> <td>M1+M2</td> <td>M1+M2</td> <td>M1+M2</td> <td>M1+M2</td> </tr> </table> <p>When the inverter is running at minimum frequency, and the PID feedback indicates that a lower speed is required, the inverter switches off (de-stages) one of the digital output controlled motors M1 and M2.</p> <p>In this case, the inverter must ramp from minimum frequency to maximum frequency outside of PID control (see P2378 and diagram below).</p> <p><b>Destaging of external motors (M1, M2)</b></p> <div style="text-align: right; margin-right: 20px;">Switch-off</div> <table style="margin-left: auto; margin-right: auto;"> <tr> <td>P2371 =</td> <td>0</td> <td>-</td> <td>-</td> <td>-</td> <td>-</td> <td>-</td> <td>-</td> <td>-</td> <td>-</td> </tr> <tr> <td>1</td> <td>M1</td> <td>-</td> <td>-</td> <td>-</td> <td>-</td> <td>-</td> <td>-</td> <td>-</td> <td>-</td> </tr> <tr> <td>2</td> <td>M1+M2</td> <td>M1</td> <td>-</td> <td>-</td> <td>-</td> <td>-</td> <td>-</td> <td>-</td> <td>-</td> </tr> <tr> <td>3</td> <td>M1+M2</td> <td>M2</td> <td>M1</td> <td>-</td> <td>-</td> <td>-</td> <td>-</td> <td>-</td> <td>-</td> </tr> </table>								P2371 =	0	-	-	-	-	-	-	-	-	1	-	M1	M1	M1	M1	M1	M1	M1	M1	2	-	M1	M1+M2	M1+M2	M1+M2	M1+M2	M1+M2	M1+M2	M1+M2	3	-	M1	M2	M1+M2	M1+M2	M1+M2	M1+M2	M1+M2	M1+M2	P2371 =	0	-	-	-	-	-	-	-	-	1	M1	-	-	-	-	-	-	-	-	2	M1+M2	M1	-	-	-	-	-	-	-	3	M1+M2	M2	M1	-	-	-	-	-	-
P2371 =	0	-	-	-	-	-	-	-	-																																																																															
1	-	M1	M1	M1	M1	M1	M1	M1	M1																																																																															
2	-	M1	M1+M2	M1+M2	M1+M2	M1+M2	M1+M2	M1+M2	M1+M2																																																																															
3	-	M1	M2	M1+M2	M1+M2	M1+M2	M1+M2	M1+M2	M1+M2																																																																															
P2371 =	0	-	-	-	-	-	-	-	-																																																																															
1	M1	-	-	-	-	-	-	-	-																																																																															
2	M1+M2	M1	-	-	-	-	-	-	-																																																																															
3	M1+M2	M2	M1	-	-	-	-	-	-																																																																															
P2372[0...2]	<b>Motor staging cycling</b>	0 - 1	0	T	-	DDS	U16	3																																																																																
	<p>Enables motor cycling for the motor staging feature.</p> <p>When enabled, the motor selected for staging / destaging is based on the hours run counter P2380. When staging, the motor with the least hours is switched on. When destaging, the motor with most hours is switched off.</p> <p>If staged motors are different sizes the choice of motor is first based on required motor size, and then if there is still a choice, on hours run.</p>																																																																																							
	0	Disabled																																																																																						
	1	Enabled																																																																																						
P2373[0...2]	<b>Motor staging hysteresis [%]</b>	0.0 - 200.0	20.0	U, T	PERCENT	DDS	Float	3																																																																																
	P2373 as a percentage of PID setpoint that PID error P2273 must be exceeded before staging delay starts.																																																																																							
<b>Note:</b>	The value of this parameter must always be smaller than delay override lockout timer P2377.																																																																																							
P2374[0...2]	<b>Motor staging delay [s]</b>	0 - 650	30	U, T	-	DDS	U16	3																																																																																
	Time that PID error P2273 must exceed motor staging hysteresis P2373 before staging occurs.																																																																																							

Parameter	Function	Range	Factory default	Can be changed	Scaling	Data set	Data type	Acc. Level
P2375[0...2]	<b>Motor destaging delay [s]</b>	0 - 650	30	U, T	-	DDS	U16	3
	Time that PID error P2273 must exceed motor staging hysteresis P2373 before destaging occurs.							
P2376[0...2]	<b>Motor staging delay override [%]</b>	0.0 - 200.0	25.0	U, T	PERCENT	DDS	Float	3
	P2376 as a percentage of PID setpoint. When the PID error P2273 exceeds this value, a motor is staged / destaged irrespective of the delay timers.							
<b>Note:</b>	The value of this parameter must always be larger than staging hysteresis P2373.							
P2377[0...2]	<b>Motor staging lockout timer [s]</b>	0 - 650	30	U, T	-	DDS	U16	3
	Time for which delay override is prevented after a motor has been staged or destaged. This prevents a second staging event immediately after a first, being caused by the transient conditions after the first staging event.							
P2378[0...2]	<b>CO: Motor staging frequency f<sub>st</sub> [%]</b>	0.0 - 120.0	50.0	U, T	PERCENT	DDS	Float	3
	<p>The frequency as a percentage of maximum frequency. During a (de) staging event, as the inverter ramps from maximum to minimum frequency (or vice versa) this is the frequency at which the digital output is switched.</p> <p>This is illustrated by the following diagrams.</p> <p><b>Staging:</b></p> <p>Condition for staging:</p> <ul style="list-style-type: none"> <li>Ⓐ <math>f_{act} \geq P1082</math></li> <li>Ⓑ <math>\Delta_{PID} \geq P2373</math></li> <li>Ⓒ <math>t_{\text{Ⓐ}\text{Ⓑ}} &gt; P2374</math></li> </ul> $t_y = \left(1 - \frac{P2378}{100}\right) \cdot P1121$							

Parameter	Function	Range	Factory default	Can be changed	Scaling	Data set	Data type	Acc. Level
	<p><b>Destaging:</b></p> <p>Condition for destaging:</p> <p>Ⓐ <math>f_{act} \leq P1080</math>  Ⓑ <math>\Delta_{PID} \leq -P2373</math>  Ⓒ <math>t_{(a)(b)} &gt; P2375</math></p> $t_x = \left( \frac{P2378}{100} - \frac{P1080}{P1082} \right) \cdot P1120$							
r2379.0...1	<b>CO / BO: Motor staging status word</b>	-	-	-	-	-	U16	3
	Output word from the motor staging feature that allows external connections to be made.							
	<b>Bit</b>	<b>Signal name</b>	<b>1 signal</b>		<b>0 signal</b>			
	00	Start motor 1	Yes		No			
	01	Start motor 2	Yes		No			
P2380[0...2]	<b>Motor staging hours run [h]</b>	0.0 - 429496720.0	0.0	U, T	-	-	Float	3
	Displays hours run for external motors. To reset the running hours, set the value to zero, any other value is ignored.							
<b>Example:</b>	P2380 = 0.1 ==> 6 min 60 min = 1 h							
<b>Index:</b>	[0]	Motor 1 hrs run						
	[1]	Motor 2 hrs run						
	[2]	Not used						
P2800	<b>Enable FFBs</b>	0 - 1	0	U, T	-	-	U16	3
	Free function blocks (FFB) are enabled in two steps: 1. P2800 enables all free function blocks (P2800 = 1). 2. P2801 and P2802 respectively, enable each free function block individually. Additionally fast free function blocks can be enabled via P2803 = 1.							

Parameter	Function	Range	Factory default	Can be changed	Scaling	Data set	Data type	Acc. Level
	0	Disable						
	1	Enable						
<b>Dependency:</b>	All active function blocks will be calculated in every 128 ms, fast free function blocks in every 8 ms.							
P2801[0...16]	<b>Activate FFBs</b>	0 - 6	0	U, T	-	-	U16	3
	<p>P2801 and P2802 respectively, enable each free function block individually (P2801[x] &gt; 0 or P2802[x] &gt; 0). In addition, P2801 and P2802 determine the chronological order of each function block by setting the level in which the free function block will work.</p> <p>The following table shows that the priority decreases from right to left and from top to bottom.</p>							
	0	Not Active						
	1	Level 1						
	2	Level 2						
	...	...						
	6	Level 6						
<b>Example:</b>	P2801[3] = 2, P2801[4] = 2, P2802[3] = 3, P2802[4] = 2 FFBs will be calculated in following order: P2802[3], P2801[3], P2801[4], P2802[4]							
<b>Index:</b>	[0]	Enable AND 1						
	[1]	Enable AND 2						
	[2]	Enable AND 3						
	[3]	Enable OR 1						
	[4]	Enable OR 2						
	[5]	Enable OR 3						
	[6]	Enable XOR 1						
	[7]	Enable XOR 2						
	[8]	Enable XOR 3						
	[9]	Enable NOT 1						
	[10]	Enable NOT 2						

Parameter	Function	Range	Factory default	Can be changed	Scaling	Data set	Data type	Acc. Level
	[11]	Enable NOT 3						
	[12]	Enable D-FF 1						
	[13]	Enable D-FF 2						
	[14]	Enable RS-FF 1						
	[15]	Enable RS-FF 2						
	[16]	Enable RS-FF 3						
<b>Dependency:</b>	Set P2800 to 1 to enable function blocks. All active function blocks will be calculated in every 128 ms, if set to level 1 to 3. Fast free function blocks (level 4 to 6) will be calculated in every 8 ms.							
P2802[0...13]	<b>Activate FFBs</b>	0 - 3	0	U, T	-	-	U16	3
	Enables free function blocks (FFB) and determines the chronological order of each function block. See P2801.							
	0	Not Active						
	1	Level 1						
	2	Level 2						
	3	Level 3						
<b>Index:</b>	[0]	Enable timer 1						
	[1]	Enable timer 2						
	[2]	Enable timer 3						
	[3]	Enable timer 4						
	[4]	Enable ADD 1						
	[5]	Enable ADD 2						
	[6]	Enable SUB 1						
	[7]	Enable SUB 2						
	[8]	Enable MUL 1						
	[9]	Enable MUL 2						
	[10]	Enable DIV 1						
	[11]	Enable DIV 2						
	[12]	Enable CMP 1						
	[13]	Enable CMP 2						
<b>Dependency:</b>	Set P2800 to 1 to enable function blocks. All active function blocks, enabled with P2802, will be calculated in every 128 ms.							
P2803[0...2]	<b>Enable Fast FFBs</b>	0 - 1	0	U, T	-	CDS	U16	3
	Fast free function blocks (FFB) are enabled in two steps: 1. P2803 enables the use of fast free function blocks (P2803 = 1). 2. P2801 enables each fast free function block individually and determines the chronological order (P2801[x] = 4 to 6).							
	0	Disable						
	1	Enable						
<b>Dependency:</b>	All active fast function blocks will be calculated in every 8 ms.							
<b>Note:</b>	Attention: P2200 and P2803 are locked parameter against each other. PID and FFB of the same data set cannot be active at same time.							
P2810[0...1]	<b>BI: AND 1</b>	0 - 4294967295	0	U, T	-	-	U32	3

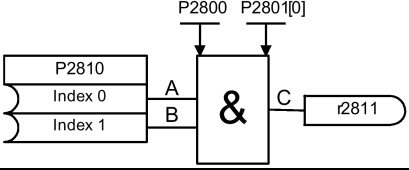
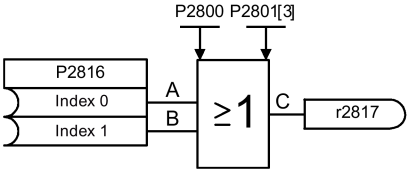
Parameter	Function	Range	Factory default	Can be changed	Scaling	Data set	Data type	Acc. Level																
	P2810[0], P2810[1] define inputs of AND 1 element, output is r2811. <div style="display: flex; align-items: center; justify-content: center;">  <table border="1" style="margin-left: 20px;"> <thead> <tr> <th>A</th> <th>B</th> <th>C</th> </tr> </thead> <tbody> <tr><td>0</td><td>0</td><td>0</td></tr> <tr><td>0</td><td>1</td><td>0</td></tr> <tr><td>1</td><td>0</td><td>0</td></tr> <tr><td>1</td><td>1</td><td>1</td></tr> </tbody> </table> </div>									A	B	C	0	0	0	0	1	0	1	0	0	1	1	1
A	B	C																						
0	0	0																						
0	1	0																						
1	0	0																						
1	1	1																						
<b>Index:</b>	[0]	Binector input 0 (BI 0)																						
	[1]	Binector input 1 (BI 1)																						
<b>Dependency:</b>	P2801[0] assigns the AND element to the processing sequence.																							
r2811.0	<b>BO: AND 1</b>	-	-	-	-	-	U16	3																
	Output of AND 1 element. Displays and logic of bits defined in P2810[0], P2810[1].																							
	<b>Bit</b>	<b>Signal name</b>			<b>1 signal</b>		<b>0 signal</b>																	
	00	Output of BO			Yes		No																	
<b>Dependency:</b>	See P2810																							
P2812[0...1]	<b>BI: AND 2</b>	0 - 4294967295	0	U, T	-	-	U32	3																
	P2812[0], 2812[1] define inputs of AND 2 element, output is r2813.																							
<b>Index:</b>	See P2810																							
<b>Dependency:</b>	P2801[1] assigns the AND element to the processing sequence.																							
r2813.0	<b>BO: AND 2</b>	-	-	-	-	-	U16	3																
	Output of AND 2 element. Displays and logic of bits defined in P2812[0], P2812[1]. See r2811 for the bit field description.																							
<b>Dependency:</b>	See P2812																							
P2814[0...1]	<b>BI: AND 3</b>	0 - 4294967295	0	U, T	-	-	U32	3																
	P2814[0], P2814[1] define inputs of AND 3 element, output is r2815.																							
<b>Index:</b>	See P2810																							
<b>Dependency:</b>	P2801[2] assigns the AND element to the processing sequence.																							
r2815.0	<b>BO: AND 3</b>	-	-	-	-	-	U16	3																
	Output of AND 3 element. Displays and logic of bits defined in P2814[0], P2814[1]. See r2811 for the bit field description.																							
<b>Dependency:</b>	See P2814																							
P2816[0...1]	<b>BI: OR 1</b>	0 - 4294967295	0	U, T	-	-	U32	3																
	P2816[0], P2816[1] define inputs of OR 1 element, output is r2817. <div style="display: flex; align-items: center; justify-content: center;">  <table border="1" style="margin-left: 20px;"> <thead> <tr> <th>A</th> <th>B</th> <th>C</th> </tr> </thead> <tbody> <tr><td>0</td><td>0</td><td>0</td></tr> <tr><td>0</td><td>1</td><td>1</td></tr> <tr><td>1</td><td>0</td><td>1</td></tr> <tr><td>1</td><td>1</td><td>1</td></tr> </tbody> </table> </div>									A	B	C	0	0	0	0	1	1	1	0	1	1	1	1
A	B	C																						
0	0	0																						
0	1	1																						
1	0	1																						
1	1	1																						
<b>Index:</b>	See P2810																							
<b>Dependency:</b>	P2801[3] assigns the OR element to the processing sequence.																							
r2817.0	<b>BO: OR 1</b>	-	-	-	-	-	U16	3																
	Output of OR 1 element. Displays or logic of bits defined in P2816[0], P2816[1]. See r2811 for the bit field description.																							
<b>Dependency:</b>	See P2816																							

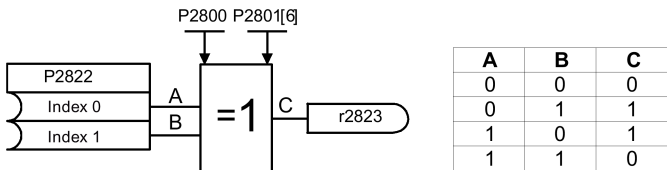

Parameter	Function	Range	Factory default	Can be changed	Scaling	Data set	Data type	Acc. Level															
P2818[0...1]	<b>BI: OR 2</b>	0 - 4294967295	0	U, T	-	-	U32	3															
	P2818[0], P2818[1] define inputs of OR 2 element, output is r2819.																						
<b>Index:</b>	See P2810																						
<b>Dependency:</b>	P2801[4] assigns the OR element to the processing sequence.																						
r2819.0	<b>BO: OR 2</b>	-	-	-	-	-	U16	3															
	Output of OR 2 element. Displays or logic of bits defined in P2818[0], P2818[1]. See r2811 for the bit field description.																						
<b>Dependency:</b>	See P2818																						
P2820[0...1]	<b>BI: OR 3</b>	0 - 4294967295	0	U, T	-	-	U32	3															
	P2820[0], P2820[1] define inputs of OR 3 element, output is r2821.																						
<b>Index:</b>	See P2810																						
<b>Dependency:</b>	P2801[5] assigns the OR element to the processing sequence.																						
r2821.0	<b>BO: OR 3</b>	-	-	-	-	-	U16	3															
	Output of OR 3 element. Displays or logic of bits defined in P2820[0], P2820[1]. See r2811 for the bit field description.																						
<b>Dependency:</b>	See P2820																						
P2822[0...1]	<b>BI: XOR 1</b>	0 - 4294967295	0	U, T	-	-	U32	3															
	P2822[0], P2822[1] define inputs of XOR 1 element, output is r2823.																						
	 <p>The diagram shows an XOR gate with inputs A and B, and output C. The inputs are labeled P2822[Index 0] and P2822[Index 1]. The output is labeled r2823. The truth table is as follows:</p> <table border="1" style="display: inline-table; vertical-align: middle;"> <thead> <tr> <th>A</th> <th>B</th> <th>C</th> </tr> </thead> <tbody> <tr> <td>0</td> <td>0</td> <td>0</td> </tr> <tr> <td>0</td> <td>1</td> <td>1</td> </tr> <tr> <td>1</td> <td>0</td> <td>1</td> </tr> <tr> <td>1</td> <td>1</td> <td>0</td> </tr> </tbody> </table>								A	B	C	0	0	0	0	1	1	1	0	1	1	1	0
A	B	C																					
0	0	0																					
0	1	1																					
1	0	1																					
1	1	0																					
<b>Index:</b>	See P2810																						
<b>Dependency:</b>	P2801[6] assigns the XOR element to the processing sequence.																						
r2823.0	<b>BO: XOR 1</b>	-	-	-	-	-	U16	3															
	Output of XOR 1 element. Displays exclusive-or logic of bits defined in P2822[0], P2822[1]. See r2811 for the bit field description.																						
<b>Dependency:</b>	See P2822																						
P2824[0...1]	<b>BI: XOR 2</b>	0 - 4294967295	0	U, T	-	-	U32	3															
	P2824[0], P2824[1] define inputs of XOR 2 element, output is r2825.																						
<b>Index:</b>	See P2810																						
<b>Dependency:</b>	P2801[7] assigns the XOR element to the processing sequence.																						
r2825.0	<b>BO: XOR 2</b>	-	-	-	-	-	U16	3															
	Output of XOR 2 element. Displays exclusive-or logic of bits defined in P2824[0], P2824[1]. See r2811 for the bit field description.																						
<b>Dependency:</b>	See P2824																						
P2826[0...1]	<b>BI: XOR 3</b>	0 - 4294967295	0	U, T	-	-	U32	3															
	P2826[0], P2826[1] define inputs of XOR 3 element, output is r2827.																						
<b>Index:</b>	See P2810																						
<b>Dependency:</b>	P2801[8] assigns the XOR element to the processing sequence.																						

7.2 Parameter list

Parameter	Function	Range	Factory default	Can be changed	Scaling	Data set	Data type	Acc. Level						
r2827.0	<b>BO: XOR 3</b>	-	-	-	-	-	U16	3						
	Output of XOR 3 element. Displays exclusive-or logic of bits defined in P2826[0], P2826[1]. See r2811 for the bit field description.													
<b>Dependency:</b>	See P2826													
P2828	<b>BI: NOT 1</b>	0 - 429496729 5	0	U, T	-	-	U32	3						
	P2828 defines input of NOT 1 element, output is r2829.													
	<table border="1" style="display: inline-table; margin-left: 20px;"> <thead> <tr> <th>A</th> <th>C</th> </tr> </thead> <tbody> <tr> <td>0</td> <td>1</td> </tr> <tr> <td>1</td> <td>0</td> </tr> </tbody> </table>								A	C	0	1	1	0
A	C													
0	1													
1	0													
<b>Dependency:</b>	P2801[9] assigns the NOT element to the processing sequence.													
r2829.0	<b>BO: NOT 1</b>	-	-	-	-	-	U16	3						
	Output of NOT 1 element. Displays not logic of bit defined in P2828. See r2811 for the bit field description.													
<b>Dependency:</b>	See P2828													
P2830	<b>BI: NOT 2</b>	0 - 429496729 5	0	U, T	-	-	U32	3						
	P2830 defines input of NOT 2 element, output is r2831.													
<b>Dependency:</b>	P2801[10] assigns the NOT element to the processing sequence.													
r2831.0	<b>BO: NOT 2</b>	-	-	-	-	-	U16	3						
	Output of NOT 2 element. Displays not logic of bit defined in P2830. See r2811 for the bit field description.													
<b>Dependency:</b>	See P2830													
P2832	<b>BI: NOT 3</b>	0 - 429496729 5	0	U, T	-	-	U32	3						
	P2832 defines input of NOT 3 element, output is r2833.													
<b>Dependency:</b>	P2801[11] assigns the NOT element to the processing sequence.													
r2833.0	<b>BO: NOT 3</b>	-	-	-	-	-	U16	3						
	Output of NOT 3 element. Displays not logic of bit defined in P2832. See r2811 for the bit field description.													
<b>Dependency:</b>	See P2832													
P2834[0...3]	<b>BI: D-FF 1</b>	0 - 429496729 5	0	U, T	-	-	U32	3						

Parameter	Function	Range	Factory default	Can be changed	Scaling	Data set	Data type	Acc. Level																																										
	<p>P2834[0], P2834[1], P2834[2], P2834[3] define inputs of D-FlipFlop 1, outputs are r2835, r2836.</p> <table border="1"> <thead> <tr> <th>SET</th> <th>RESET</th> <th>D</th> <th>STORE</th> <th>Q</th> <th><math>\bar{Q}</math></th> </tr> </thead> <tbody> <tr> <td>1</td> <td>0</td> <td>x</td> <td>x</td> <td>1</td> <td>0</td> </tr> <tr> <td>0</td> <td>1</td> <td>x</td> <td>x</td> <td>0</td> <td>1</td> </tr> <tr> <td>1</td> <td>1</td> <td>x</td> <td>x</td> <td><math>Q_{n-1}</math></td> <td><math>\bar{Q}_{n-1}</math></td> </tr> <tr> <td>0</td> <td>0</td> <td>1</td> <td><math>\uparrow</math></td> <td>1</td> <td>0</td> </tr> <tr> <td>0</td> <td>0</td> <td>0</td> <td><math>\uparrow</math></td> <td>0</td> <td>1</td> </tr> <tr> <td colspan="4">POWER-ON</td> <td>0</td> <td>1</td> </tr> </tbody> </table>								SET	RESET	D	STORE	Q	$\bar{Q}$	1	0	x	x	1	0	0	1	x	x	0	1	1	1	x	x	$Q_{n-1}$	$\bar{Q}_{n-1}$	0	0	1	$\uparrow$	1	0	0	0	0	$\uparrow$	0	1	POWER-ON				0	1
SET	RESET	D	STORE	Q	$\bar{Q}$																																													
1	0	x	x	1	0																																													
0	1	x	x	0	1																																													
1	1	x	x	$Q_{n-1}$	$\bar{Q}_{n-1}$																																													
0	0	1	$\uparrow$	1	0																																													
0	0	0	$\uparrow$	0	1																																													
POWER-ON				0	1																																													
<b>Index:</b>	[0]	Binector input: Set																																																
	[1]	Binector input: D input																																																
	[2]	Binector input: Store pulse																																																
	[3]	Binector input: Reset																																																
<b>Dependency:</b>	P2801[12] assigns the D-FlipFlop to the processing sequence.																																																	
r2835.0	<b>BO: Q D-FF 1</b>	-	-	-	-	-	U16	3																																										
	Displays output of D-FlipFlop 1, inputs are defined in P2834[0], P2834[1], P2834[2], P2834[3]. See r2811 for the bit field description.																																																	
<b>Dependency:</b>	See P2834																																																	
r2836.0	<b>BO: NOT-Q D-FF 1</b>	-	-	-	-	-	U16	3																																										
	Displays Not-output of D-FlipFlop 1, inputs are defined in P2834[0], P2834[1], P2834[2], P2834[3]. See r2811 for the bit field description.																																																	
<b>Dependency:</b>	See P2834																																																	
P2837[0...3]	<b>BI: D-FF 2</b>	0 - 429496729 5	0	U, T	-	-	U32	3																																										
	P2837[0], P2837[1], P2837[2], P2837[3] define inputs of D-FlipFlop 2, outputs are r2838, r2839.																																																	
<b>Index:</b>	See P2834																																																	
<b>Dependency:</b>	P2801[13] assigns the D-FlipFlop to the processing sequence.																																																	
r2838.0	<b>BO: Q D-FF 2</b>	-	-	-	-	-	U16	3																																										
	Displays output of D-FlipFlop 2, inputs are defined in P2837[0], P2837[1], P2837[2], P2837[3]. See r2811 for the bit field description.																																																	
<b>Dependency:</b>	See P2837																																																	
r2839.0	<b>BO: NOT-Q D-FF 2</b>	-	-	-	-	-	U16	3																																										
	Displays Not-output of D-FlipFlop 2, inputs are defined in P2837[0], P2837[1], P2837[2], P2837[3]. See r2811 for the bit field description.																																																	
<b>Dependency:</b>	See P2837																																																	

Parameter	Function	Range	Factory default	Can be changed	Scaling	Data set	Data type	Acc. Level																								
P2840[0...1]	<b>BI: RS-FF 1</b>	0 - 429496729 5	0	U, T	-	-	U32	3																								
<p>P2840[0], P2840[1] define inputs of RS-FlipFlop 1, outputs are r2841, r2842.</p> <table border="1" style="float: right;"> <thead> <tr> <th>SET</th> <th>RESET</th> <th>Q</th> <th><math>\bar{Q}</math></th> </tr> </thead> <tbody> <tr> <td>0</td> <td>0</td> <td><math>Q_{n-1}</math></td> <td><math>\bar{Q}_{n-1}</math></td> </tr> <tr> <td>0</td> <td>1</td> <td>0</td> <td>1</td> </tr> <tr> <td>1</td> <td>0</td> <td>1</td> <td>0</td> </tr> <tr> <td>1</td> <td>1</td> <td><math>Q_{n-1}</math></td> <td><math>\bar{Q}_{n-1}</math></td> </tr> <tr> <td>POWER-ON</td> <td>0</td> <td>1</td> <td></td> </tr> </tbody> </table>									SET	RESET	Q	$\bar{Q}$	0	0	$Q_{n-1}$	$\bar{Q}_{n-1}$	0	1	0	1	1	0	1	0	1	1	$Q_{n-1}$	$\bar{Q}_{n-1}$	POWER-ON	0	1	
SET	RESET	Q	$\bar{Q}$																													
0	0	$Q_{n-1}$	$\bar{Q}_{n-1}$																													
0	1	0	1																													
1	0	1	0																													
1	1	$Q_{n-1}$	$\bar{Q}_{n-1}$																													
POWER-ON	0	1																														
<b>Index:</b>	[0]	Binector input: Set																														
	[1]	Binector input: Reset																														
<b>Dependency:</b>	P2801[14] assigns the RS-FlipFlop to the processing sequence.																															
r2841.0	<b>BO: Q RS-FF 1</b>	-	-	-	-	-	U16	3																								
Displays output of RS-FlipFlop 1, inputs are defined in P2840[0], P2840[1]. See r2811 for the bit field description.																																
<b>Dependency:</b>	See P2840																															
r2842.0	<b>BO: NOT-Q RS-FF 1</b>	-	-	-	-	-	U16	3																								
Displays Not-output of RS-FlipFlop 1, inputs are defined in P2840[0], P2840[1]. See r2811 for the bit field description.																																
<b>Dependency:</b>	See P2840																															
P2843[0...1]	<b>BI: RS-FF 2</b>	0 - 429496729 5	0	U, T	-	-	U32	3																								
P2843[0], P2843[1] define inputs of RS-FlipFlop 2, outputs are r2844, r2845.																																
<b>Index:</b>	See P2840																															
<b>Dependency:</b>	P2801[15] assigns the RS-FlipFlop to the processing sequence.																															
r2844.0	<b>BO: Q RS-FF 2</b>	-	-	-	-	-	U16	3																								
Displays output of RS-FlipFlop 2, inputs are defined in P2843[0], P2843[1]. See r2811 for the bit field description.																																
<b>Dependency:</b>	See P2843																															
r2845.0	<b>BO: NOT-Q RS-FF 2</b>	-	-	-	-	-	U16	3																								
Displays Not-output of RS-FlipFlop 2, inputs are defined in P2843[0], P2843[1]. See r2811 for the bit field description.																																
<b>Dependency:</b>	See P2843																															
P2846[0...1]	<b>BI: RS-FF 3</b>	0 - 429496729 5	0	U, T	-	-	U32	3																								
P2846[0], P2846[1] define inputs of RS-FlipFlop 3, outputs are r2847, r2848.																																
<b>Index:</b>	See P2840																															
<b>Dependency:</b>	P2801[16] assigns the RS-FlipFlop to the processing sequence.																															
r2847.0	<b>BO: Q RS-FF 3</b>	-	-	-	-	-	U16	3																								
Displays output of RS-FlipFlop 3, inputs are defined in P2846[0], P2846[1]. See r2811 for the bit field description.																																
<b>Dependency:</b>	See P2846																															
r2848.0	<b>BO: NOT-Q RS-FF 3</b>	-	-	-	-	-	U16	3																								

Parameter	Function	Range	Factory default	Can be changed	Scaling	Data set	Data type	Acc. Level
	Displays Not-output of RS-FlipFlop 3, inputs are defined in P2846[0], P2846[1]. See r2811 for the bit field description.							
<b>Dependency:</b>	See P2846							
P2849	<b>BI: Timer 1</b>	0 - 429496729 5	0	U, T	-	-	U32	3

Define input signal of timer 1. P2849, P2850, P2851 are the inputs of the timer, outputs are r2852, r2853.

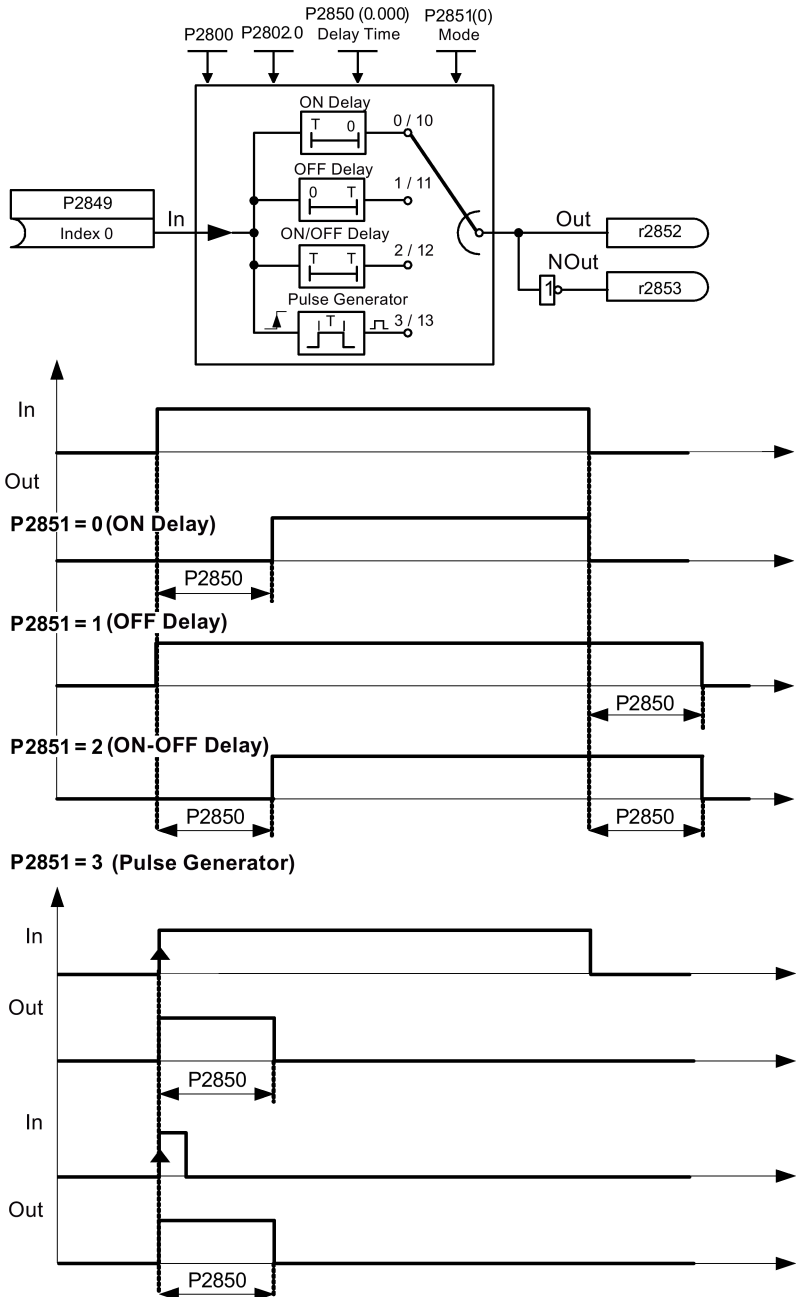

Parameter list

7.2 Parameter list

Parameter	Function	Range	Factory default	Can be changed	Scaling	Data set	Data type	Acc. Level
<b>Dependency:</b>	P2802[0] assigns the timer to the processing sequence.							
P2850	<b>Delay time of timer 1 [s]</b>	0.0 - 9999.9	0.0	U, T	-	-	Float	3
	Defines delay time of timer 1. P2849, P2850, P2851 are the inputs of the timer, outputs are r2852, r2853.							
<b>Dependency:</b>	See P2849							
P2851	<b>Mode timer 1</b>	0 - 13	0	U, T	-	-	U16	3
	Selects mode of timer 1. P2849, P2850, P2851 are the inputs of the timer, outputs are r2852, r2853.							
	0	ON delay (seconds)						
	1	OFF delay (seconds)						
	2	ON / OFF delay (seconds)						
	3	Pulse generator (seconds)						
	10	ON delay (minutes)						
	11	OFF delay (minutes)						
	12	ON / OFF delay (minutes)						
	13	Pulse generator (minutes)						
<b>Dependency:</b>	See P2849							
r2852.0	<b>BO: Timer 1</b>	-	-	-	-	-	U16	3
	Displays output of timer 1. P2849, P2850, P2851 are the inputs of the timer, outputs are r2852, r2853. See r2811 for the bit field description.							
<b>Dependency:</b>	See P2849							
r2853.0	<b>BO: Nout timer 1</b>	-	-	-	-	-	U16	3
	Displays Not-output of timer 1. P2849, P2850, P2851 are the inputs of the timer, outputs are r2852, r2853. See r2811 for the bit field description.							
<b>Dependency:</b>	See P2849							
P2854	<b>BI: Timer 2</b>	0 - 429496729 5	0	U, T	-	-	U32	3
	Define input signal of timer 2. P2854, P2855, P2856 are the inputs of the timer, outputs are r2857, r2858.							
<b>Dependency:</b>	P2802[1] assigns the timer to the processing sequence.							
P2855	<b>Delay time of timer 2 [s]</b>	0.0 - 9999.9	0.0	U, T	-	-	Float	3
	Defines delay time of timer 2. P2854, P2855, P2856 are the inputs of the timer, outputs are r2857, r2858.							
<b>Dependency:</b>	See P2854							
P2856	<b>Mode timer 2</b>	0 - 13	0	U, T	-	-	U16	3
	Selects mode of timer 2. P2854, P2855, P2856 are the inputs of the timer, outputs are r2857, r2858. See P2851 for value description.							
<b>Dependency:</b>	See P2854							
r2857.0	<b>BO: Timer 2</b>	-	-	-	-	-	U16	3
	Displays output of timer 2. P2854, P2855, P2856 are the inputs of the timer, outputs are r2857, r2858. See r2811 for the bit field description.							
<b>Dependency:</b>	See P2854							
r2858.0	<b>BO: Nout timer 2</b>	-	-	-	-	-	U16	3
	Displays Not-output of timer 2 P2854, P2855, P2856 are the inputs of the timer, outputs are r2857, r2858. See r2811 for the bit field description.							
<b>Dependency:</b>	See P2854							

Parameter	Function	Range	Factory default	Can be changed	Scaling	Data set	Data type	Acc. Level
P2859	<b>BI: Timer 3</b>	0 - 429496729 5	0	U, T	-	-	U32	3
	Define input signal of timer 3. P2859, P2860, P2861 are the inputs of the timer, outputs are r2862, r2863.							
<b>Dependency:</b>	P2802[2] assigns the timer to the processing sequence.							
P2860	<b>Delay time of timer 3 [s]</b>	0.0 - 9999.9	0.0	U, T	-	-	Float	3
	Defines delay time of timer 3. P2859, P2860, P2861 are the inputs of the timer, outputs are r2862, r2863.							
<b>Dependency:</b>	See P2859							
P2861	<b>Mode timer 3</b>	0 - 13	0	U, T	-	-	U16	3
	Selects mode of timer 3. P2859, P2860, P2861 are the inputs of the timer, outputs are r2862, r2863. See P2851 for value description.							
<b>Dependency:</b>	See P2859							
r2862.0	<b>BO: Timer 3</b>	-	-	-	-	-	U16	3
	Displays output of timer 3. P2859, P2860, P2861 are the inputs of the timer, outputs are r2862, r2863. See r2811 for the bit field description.							
<b>Dependency:</b>	See P2859							
r2863.0	<b>BO: Nout timer 3</b>	-	-	-	-	-	U16	3
	Displays Not-output of timer 3. P2859, P2860, P2861 are the inputs of the timer, outputs are r2862, r2863. See r2811 for the bit field description.							
<b>Dependency:</b>	See P2859							
P2864	<b>BI: Timer 4</b>	0 - 429496729 5	0	U, T	-	-	U32	3
	Define input signal of timer 4. P2864, P2865, P2866 are the inputs of the timer, outputs are P2867, P2868.							
<b>Dependency:</b>	P2802[3] assigns the timer to the processing sequence.							
P2865	<b>Delay time of timer 4 [s]</b>	0.0 - 9999.9	0.0	U, T	-	-	Float	3
	Defines delay time of timer 4. P2864, P2865, P2866 are the inputs of the timer, outputs are r2867, r2868.							
<b>Dependency:</b>	See P2864							
P2866	<b>Mode timer 4</b>	0 - 13	0	U, T	-	-	U16	3
	Selects mode of timer 4. P2864, P2865, P2866 are the inputs of the timer, outputs are r2867, r2868. See P2851 for value description.							
<b>Dependency:</b>	See P2864							
r2867.0	<b>BO: Timer 4</b>	-	-	-	-	-	U16	3
	Displays output of timer 4. P2864, P2865, P2866 are the inputs of the timer, outputs are r2867, r2868. See r2811 for the bit field description.							
<b>Dependency:</b>	See P2864							
r2868.0	<b>BO: Nout timer 4</b>	-	-	-	-	-	U16	3
	Displays Not-output of timer 4. P2864, P2865, P2866 are the inputs of the timer, outputs are r2867, r2868. See r2811 for the bit field description.							
<b>Dependency:</b>	See P2864							
P2869[0...1]	<b>CI: ADD 1</b>	0 - 429496729 5	0	U, T	4000H	-	U32	3

7.2 Parameter list

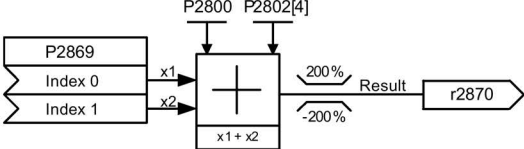
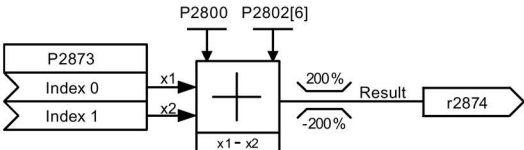
Parameter	Function	Range	Factory default	Can be changed	Scaling	Data set	Data type	Acc. Level	
	Define inputs of Adder 1, result is in r2870.  <p><b>Result = <math>x1 + x2</math></b>                      If: <math>x1 + x2 &gt; 200\% \rightarrow</math> Result = 200%  <math>x1 + x2 &lt; -200\% \rightarrow</math> Result = -200%</p>								
<b>Index:</b>	[0]	Connector input 0 (CI 0)							
	[1]	Connector input 1 (CI 1)							
<b>Dependency:</b>	P2802[4] assigns the Adder to the processing sequence.								
r2870	<b>CO: ADD 1</b>	-	-	-	-	-	Float	3	
	Result of Adder 1.								
<b>Dependency:</b>	See P2869								
P2871[0...1]	<b>CI: ADD 2</b>	0 - 429496729 5	0	U, T	4000H	-	U32	3	
	Define inputs of Adder 2, result is in r2872.								
<b>Index:</b>	See P2869								
<b>Dependency:</b>	P2802[5] assigns the Adder to the processing sequence.								
r2872	<b>CO: ADD 2</b>	-	-	-	-	-	Float	3	
	Result of Adder 2.								
<b>Dependency:</b>	See P2871								
P2873[0...1]	<b>CI: SUB 1</b>	0 - 429496729 5	0	U, T	4000H	-	U32	3	
	Define inputs of Subtractor 1, result is in r2874.								
	 <p><b>Result = <math>x1 - x2</math></b>                      If: <math>x1 - x2 &gt; 200\% \rightarrow</math> Result = 200%  <math>x1 - x2 &lt; -200\% \rightarrow</math> Result = -200%</p>								
<b>Index:</b>	See P2869								
<b>Dependency:</b>	P2802[6] assigns the Subtractor to the processing sequence.								
r2874	<b>CO: SUB 1</b>	-	-	-	-	-	Float	3	
	Result of Subtractor 1.								
<b>Dependency:</b>	See P2873								
P2875[0...1]	<b>CI: SUB 2</b>	0 - 429496729 5	0	U, T	4000H	-	U32	3	
	Define inputs of Subtractor 2, result is in r2876.								
<b>Index:</b>	See P2869								
<b>Dependency:</b>	P2802[7] assigns the Subtractor to the processing sequence.								
r2876	<b>CO: SUB 2</b>	-	-	-	-	-	Float	3	

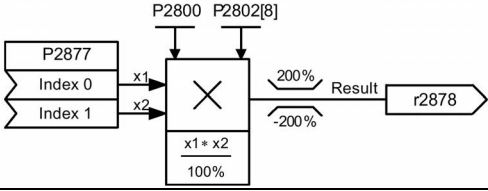
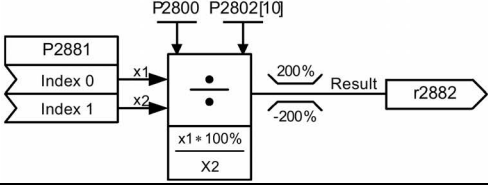

Parameter	Function	Range	Factory default	Can be changed	Scaling	Data set	Data type	Acc. Level
	Result of Subtractor 2.							
<b>Dependency:</b>	See P2875							
P2877[0...1]	<b>CI: MUL 1</b>	0 - 429496729 5	0	U, T	4000H	-	U32	3
	Define inputs of Multiplier 1, result is in r2878.  $\text{Result} = \frac{x1 * x2}{100\%}$ <p>If: <math>\frac{x1 * x2}{100\%} &gt; 200\% \rightarrow \text{Result} = 200\%</math>  <math>\frac{x1 * x2}{100\%} &lt; -200\% \rightarrow \text{Result} = -200\%</math></p>							
<b>Index:</b>	See P2869							
<b>Dependency:</b>	P2802[8] assigns the Multiplier to the processing sequence.							
r2878	<b>CO: MUL 1</b>	-	-	-	-	-	Float	3
	Result of Multiplier 1.							
<b>Dependency:</b>	See P2877							
P2879[0...1]	<b>CI: MUL 2</b>	0 - 429496729 5	0	U, T	4000H	-	U32	3
	Define inputs of Multiplier 2, result is in r2880.							
<b>Index:</b>	See P2869							
<b>Dependency:</b>	P2802[9] assigns the Multiplier to the processing sequence.							
r2880	<b>CO: MUL 2</b>	-	-	-	-	-	Float	3
	Result of Multiplier 2.							
<b>Dependency:</b>	See P2879							
P2881[0...1]	<b>CI: DIV 1</b>	0 - 429496729 5	0	U, T	4000H	-	U32	3
	Define inputs of Divider 1, result is in r2882.  $\text{Result} = \frac{x1 * 100\%}{x2}$ <p>If: <math>\frac{x1 * 100\%}{x2} &gt; 200\% \rightarrow \text{Result} = 200\%</math>  <math>\frac{x1 * 100\%}{x2} &lt; -200\% \rightarrow \text{Result} = -200\%</math></p>							
<b>Index:</b>	See P2869							
<b>Dependency:</b>	P2802[10] assigns the Divider to the processing sequence.							
r2882	<b>CO: DIV 1</b>	-	-	-	-	-	Float	3
	Result of Divider 1.							
<b>Dependency:</b>	See P2881							
P2883[0...1]	<b>CI: DIV 2</b>	0 - 429496729 5	0	U, T	4000H	-	U32	3
	Define inputs of Divider 2, result is in r2884.							
<b>Index:</b>	See P2869							
<b>Dependency:</b>	P2802[11] assigns the Divider to the processing sequence.							

Parameter list

7.2 Parameter list

Parameter	Function	Range	Factory default	Can be changed	Scaling	Data set	Data type	Acc. Level
r2884	<b>CO: DIV 2</b>	-	-	-	-	-	Float	3
	Result of Divider 2.							
<b>Dependency:</b>	See P2883							
P2885[0...1]	<b>CI: CMP 1</b>	0 - 429496729 5	0	U, T	4000H	-	U32	3
	Defines inputs of Comparator 1, output is r2886.							
<b>Index:</b>	See P2869							
<b>Dependency:</b>	P2802[12] assigns the Comparator to the processing sequence.							
r2886.0	<b>BO: CMP 1</b>	-	-	-	-	-	Float	3
	Displays result bit of Comparator 1. See r2811 for the bit field description.							
<b>Dependency:</b>	See P2885							
P2887[0...1]	<b>CI: CMP 2</b>	0 - 429496729 5	0	U, T	4000H	-	U32	3
	Defines inputs of Comparator 2, output is r2888.							
<b>Index:</b>	See P2869							
<b>Dependency:</b>	P2802[13] assigns the Comparator to the processing sequence.							
r2888.0	<b>BO: CMP 2</b>	-	-	-	-	-	U16	3
	Displays result bit of Comparator 2. See r2811 for the bit field description.							
<b>Dependency:</b>	See P2887							
P2889	<b>CO: Fixed setpoint 1 in [%]</b>	-200.00 - 200.00	0.00	U, T	-	-	Float	3
	Fixed percent setting 1. <p>Connector Setting in %</p> <p>Range: -200% to 200%</p>							
P2890	<b>CO: Fixed setpoint 2 in [%]</b>	-200.00 - 200.00	0.00	U, T	-	-	Float	3
	Fixed percent setting 2.							
P2940	<b>BI: Release wobble function</b>	0 - 429496729 5	0.0	T	-	-	U32	2
	Defines the source to release the wobble function.							
P2945	<b>Wobble signal frequency [Hz]</b>	0.001 - 10.000	1.000	T	-	-	Float	2
	Sets the frequency of the wobble signal.							

Parameter	Function	Range	Factory default	Can be changed	Scaling	Data set	Data type	Acc. Level
P2946	<b>Wobble signal amplitude [%]</b>	0.000 - 0.200	0.000	T	-	-	Float	2
	Sets the value for the amplitude of the wobble-signal as a proportion of the present ramp function generator (RFG) output. The value of P2946 is multiplied by the output value of the RFG then added to RFG output. For example, if the RFG output is 10 Hz, and P2946 has a value of 0.100, the wobble signal amplitude will be $0.100 * 10 = 1$ Hz. This means that the RFG output will therefore wobble between 9 Hz and 11 Hz.							
P2947	<b>Wobble signal decrement step</b>	0.000 - 1.000	0.000	T	-	-	Float	2
	Sets the value for decrement step at the end of the positive signal period. The amplitude of the step is dependant upon the signal amplitude as follows: Amplitude of signal decrement step = $P2947 * P2946$							
P2948	<b>Wobble signal increment step</b>	0.000 - 1.000	0.000	T	-	-	Float	2
	Sets the value for the increment step at the end of the negative signal period. The amplitude of the increment step is dependant upon the signal amplitude as follows: Amplitude of signal increment step = $P2948 * P2946$							
P2949	<b>Wobble signal pulse width [%]</b>	0 - 100	50	T	-	-	U16	2
	Sets the relative widths of the rising and falling pulses. The value in P2949 sets the proportion of the wobble period (determined by P2945) allocated to the rising pulse, the remainder of the time is allocation to the falling pulse. A value of 60% in P2949 means that 60% of the wobble period the wobble output will be rising. For the remaining 40% of the wobble period the wobble output will be falling.							
r2955	<b>CO: Wobble signal output [%]</b>	-	-	-	-	-	Float	2
	Displays the output of the wobble function.							
r3113.0...15	<b>CO / BO: Fault bit array</b>	-	-	-	-	-	U16	1
	Gives information about actual fault.							
	<b>Bit</b>	<b>Signal name</b>			<b>1 signal</b>		<b>0 signal</b>	
	00	Inverter error			Yes		No	
	01	Power line failure			Yes		No	
	02	Intermediate circuit power voltage			Yes		No	
	03	Error power electronics			Yes		No	
	04	Inverter overtemperature			Yes		No	
	05	Earth leakage			Yes		No	
	06	Motor overload			Yes		No	
	07	Bus fault			Yes		No	
	09	Reserved			Yes		No	
	10	Fault internal communication			Yes		No	
	11	Motor current limit			Yes		No	
	12	Supply failure			Yes		No	
	13	Reserved			Yes		No	
	14	Reserved			Yes		No	

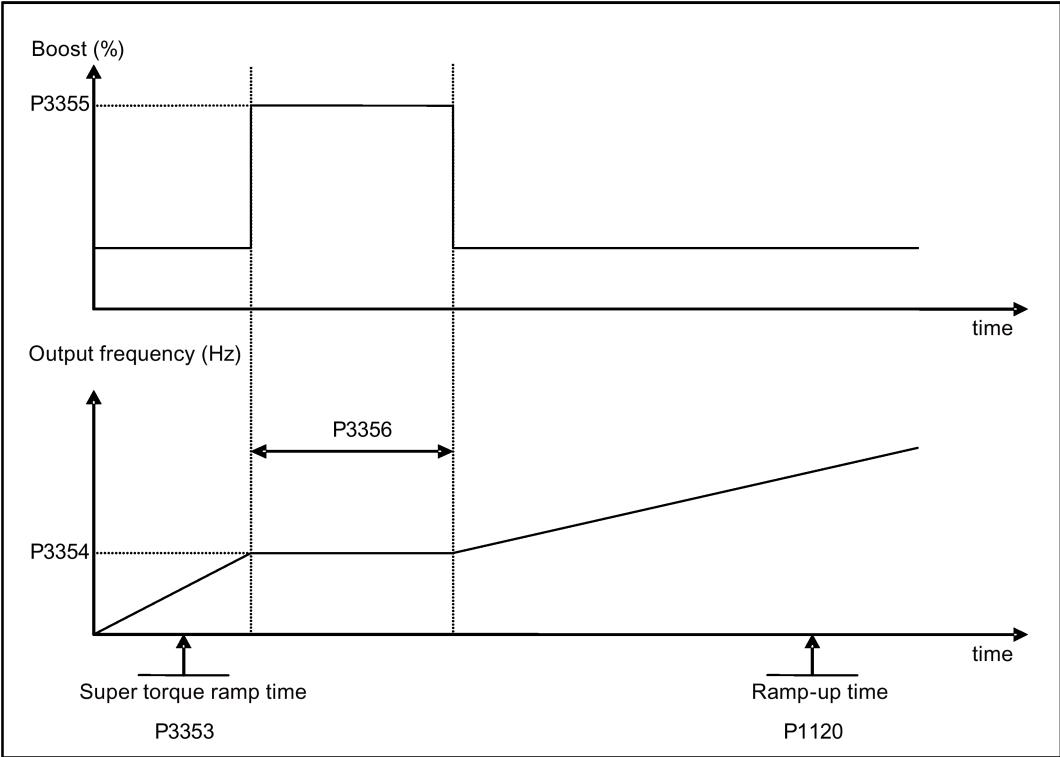
Parameter	Function	Range	Factory default	Can be changed	Scaling	Data set	Data type	Acc. Level	
	15	Other error				Yes	No		
r3237[0...1]	<b>CO: Calculated rms DC ripple voltage [V]</b>	-	0	-	-	-	Float	4	
	Displays calculated rms dc-link ripple voltage.								
<b>Index:</b>	[0]	Ripple Volts							
	[1]	Unfiltered Volts							
P3350[0...2]	<b>Super torque modes</b>	0 - 3	0	T	-	-	U16	2	
	<p>Selects the super torque function. Three different super torque modes are available:</p> <ul style="list-style-type: none"> <li>• Super Torque - applies a pulse of torque for a given time to help start the motor</li> <li>• Hammer Start - applies a sequence of torque pulses to help start the motor</li> <li>• Blockage Clearing - performs a reverse-forward operation to clear a pump blockage</li> </ul> <p><b>Super Torque Operation:</b></p> 								

Parameter	Function	Range	Factory default	Can be changed	Scaling	Data set	Data type	Acc. Level
	<p><b>Hammer Start Operation:</b></p> <p>The figure consists of two vertically aligned graphs sharing a common time axis.</p> <p>The top graph plots Boost (%) on the y-axis against time on the x-axis. It shows a series of rectangular pulses. The peak level of the pulses is indicated by a horizontal dotted line labeled P3357. The width of each pulse is indicated by a double-headed arrow labeled P3359. The time interval between the start of one pulse and the start of the next is indicated by a double-headed arrow labeled P3360.</p> <p>The bottom graph plots Output frequency (Hz) on the y-axis against time on the x-axis. It shows a frequency ramp that starts at zero, increases linearly to a level P3354, remains constant for a duration labeled 'No. of hammer cycles' (P3358), and then continues to increase linearly. The initial linear ramp is labeled 'Super torque ramp time' (P3353). The total time from the start of the ramp to the end of the constant frequency section is labeled 'Ramp-up time' (P1120).</p>							

Parameter	Function	Range	Factory default	Can be changed	Scaling	Data set	Data type	Acc. Level
<p><b>Blockage Clearing Operation:</b></p> <p>The graph shows the output frequency (Hz) over time (t) during a blockage clearing operation. The y-axis represents Output frequency (Hz) and the x-axis represents time (t). The setpoint is shown as a solid line for positive and a dashed line for negative. The frequency starts at a positive setpoint, ramps down to zero (P3353), then ramps up to a negative setpoint (P1120 Ramp-up time). This cycle repeats for a specified number of cycles (e.g., P3364 = 2). The blockage clearing reverse time is also indicated.</p>								
	0	Super torque modes disabled						
	1	Super torque enabled						
	2	Hammer start enabled						
	3	Blockage clearing enabled						
<b>Index:</b>	[0]	Inverter data set 0 (DDS0)						
	[1]	Inverter data set 1 (DDS1)						
	[2]	Inverter data set 2 (DDS2)						
<b>Note:</b>	<p>When the value of P3350 is changed, the value of P3353 is changed as follows:</p> <ul style="list-style-type: none"> <li>• P3350 = 2: P3353 = 0.0s</li> <li>• P3350 ≠ 2: P3353 = default</li> </ul> <p>The ramp time of 0s gives an additional 'kicking' effect when hammer start is in use. This setting can be overridden by the operator.</p> <p>If blockage clearing mode is enabled (P3350 = 3), make sure that reverse direction is not inhibited, i.e. P1032 = P1110 = 0.</p>							
P3351[0...2]	<b>BI: Super torque enable</b>	0 - 4294967295	0	T	-	CDS	U32	2
	Defines source of the super torque enable when P3352 = 2.							
<b>Dependency:</b>	Applies only when P3352 = 2.							
P3352[0...2]	<b>Super torque startup mode</b>	0 - 2	1	T	-	-	U16	2

Parameter	Function	Range	Factory default	Can be changed	Scaling	Data set	Data type	Acc. Level
	Defines when the super torque function becomes active.							
	0	Enabled on first run after power-up						
	1	Enabled on every run						
	2	Enabled by digital input						
<b>Index:</b>	See P3350							
<b>Dependency:</b>	If P3352 = 2, enable source is defined by P3351							
P3353[0...2]	<b>Super torque ramp time [s]</b>	0.0 - 650.0	5.0	T	-	-	Float	2
	Defines the ramp time to be used for all super torque functions. Overrides the P1120 / P1060 when inverter is ramping to super torque / hammer start frequency (P3354) or the blockage clearing frequency (P3361).							
<b>Index:</b>	See P3350							
<b>Dependency:</b>	The value of this parameter is changed by the setting of P3350. See the description of P3350.							
P3354[0...2]	<b>Super torque frequency [Hz]</b>	0.0 - 550.0	5.0	T	-	-	Float	2
	Defines the frequency at which the additional boost is applied for super torque and hammer start modes.							
<b>Index:</b>	See P3350							
P3355[0...2]	<b>Super torque boost level [%]</b>	0.0 - 200.0	150.0	T	PERCENT	-	Float	2
	The magnitude of the Super Torque boost is calculated as follows: $V_{ST} = P0305 * Rsadj * (P3355 / 100)$ Note: Rsadj = stator resistance adjusted for temperature $Rsadj = (r0395 / 100) * (P0304 / (\sqrt{3} * P0305)) * P0305 * \sqrt{3}$							
<b>Index:</b>	See P3350							
<b>Dependency:</b>	Up to 200% of rated motor current (P0305) or limit of inverter.							
<b>Note:</b>	The Super Torque boost is calculated in the same way as Continuous Boost (P1310). As the stator resistance is used, the calculated voltage is only accurate at 0 Hz. Thereafter, it will vary in the same way as Continuous Boost. Setting in P0640 (motor overload factor [%]) limits the boost.							
P3356[0...2]	<b>Super torque boost time [s]</b>	0.0 - 20.0	5.0	T	-	-	Float	2
	Sets the time for which the additional boost will be applied, when the output frequency is held at P3354 Hz.							
<b>Index:</b>	See P3350							
P3357[0...2]	<b>Hammer start boost level [%]</b>	0.0 - 200.0	150.0	T	PERCENT	-	Float	2
	The magnitude of the Hammer Start boost is calculated as follows: $V_{HS} = P0305 * Rsadj * (P3357 / 100)$ Note: Rsadj = stator resistance adjusted for temperature $Rsadj = (r0395 / 100) * (P0304 / (\sqrt{3} * P0305)) * P0305 * \sqrt{3}$							
<b>Index:</b>	See P3350							
<b>Dependency:</b>	Up to 200% of rated motor current (P0305) or limit of inverter.							

Parameter list

7.2 Parameter list

Parameter	Function	Range	Factory default	Can be changed	Scaling	Data set	Data type	Acc. Level
<b>Note:</b>	The Hammer Start boost is calculated in the same way as Continuous Boost (P1310). As the stator resistance is used, the calculated voltage is only accurate at 0Hz. Thereafter, it will vary in the same way as Continuous Boost. Setting in P0640 (motor overload factor [%]) limits the boost.							
P3358[0...2]	<b>Number of hammer cycles</b>	1 - 10	5	C, T	-	-	U16	2
	The number of times the hammer start boost level (P3357) is applied.							
<b>Index:</b>	See P3350							
P3359[0...2]	<b>Hammer on time [ms]</b>	0 - 1000	300	T	-	-	U16	2
	Time for which the additional boost is applied for each repetition.							
<b>Index:</b>	See P3350							
<b>Dependency:</b>	The time must be at least 3 x motor magnetization time (P0346).							
P3360[0...2]	<b>Hammer off Time [ms]</b>	0 - 1000	100	T	-	-	U16	2
	Time for which the additional boost is removed for each repetition.							
<b>Index:</b>	See P3350							
<b>Note:</b>	During this time, the boost level drops to the level defined by P1310 (continuous boost).							
P3361[0...2]	<b>Blockage clearing frequency [Hz]</b>	0.0 - 550.0	5.0	T	-	-	Float	2
	Defines the frequency at which the inverter runs in the opposite direction to the setpoint during the blockage clearing reverse sequence.							
<b>Index:</b>	See P3350							
P3362[0...2]	<b>Blockage clearing reverse time [s]</b>	0.0 - 20.0	5.0	T	-	-	Float	2
	Sets the time for which the inverter runs in the opposite direction to the setpoint during the reverse sequence.							
<b>Index:</b>	See P3350							
P3363[0...2]	<b>Enable rapid ramp</b>	0 - 1	0	T	-	-	U16	2
	Selects whether the inverter ramps to, or starts directly from, the blockage clearing frequency (P3361).							
	0	Disable rapid ramp for blockage clearing						
	1	Enable rapid ramp for blockage clearing						
<b>Index:</b>	See P3350							
<b>Note:</b>	If P3363 = 1, the output jumps to the reverse frequency - this introduces a "kicking" effect which helps to clear the blockage.							
P3364[0...2]	<b>Number of blockage clearing cycles</b>	1 - 10	1	T	-	-	U16	2
	The number of times the blockage clearing reversing cycle is repeated.							
<b>Index:</b>	See P3350							
r3365	<b>CO/BO: Status word: super torque</b>	-	-	-	-	-	U16	2
	Shows the operational status of the Super Torque function, while active.							
	<b>Bit</b>	<b>Signal name</b>			<b>1 signal</b>		<b>0 signal</b>	
	00	Super Torque Active			Yes		No	
	01	Super Torque Ramping			Yes		No	
	02	Super Torque Boost On			Yes		No	



Parameter	Function	Range	Factory default	Can be changed	Scaling	Data set	Data type	Acc. Level
	03	Super Torque Boost Off			Yes		No	
	04	Blockage Clearing Reverse On			Yes		No	
	05	Blockage Clearing Reverse Off			Yes		No	
P3852[0...2]	<b>BI: Enable frost protection</b>	0 - 4294967295	0	U, T	-	CDS	U32	2
	<p>Defines command source of protection enable command. If binary input is equal to one, then protection will be initiated. If inverter is stopped and protection signal becomes active, protection measure is applied as follows:</p> <ul style="list-style-type: none"> <li>• If P3853 <math>\neq</math> 0, frost protection is applied by applying the given frequency to the motor</li> <li>• If P3853 = 0, and P3854 <math>\neq</math> 0, condensation protection is applied by applying the given current to the motor</li> </ul>							
<b>Note:</b>	<p>The protection function may be overridden under the following circumstances:</p> <ul style="list-style-type: none"> <li>• If inverter is running and protection signal becomes active, signal is ignored</li> <li>• If inverter is turning motor due to active protection signal and a RUN command is received, RUN command overrides frost signal</li> <li>• Issuing an OFF command while protection is active will stop the motor</li> </ul>							
P3853[0...2]	<b>Frost protection frequency [Hz]</b>	0.00 - 550.00	5.00	U, T	-	DDS	Float	2
	The frequency applied to the motor when frost protection is active.							
<b>Dependency:</b>	See also P3852.							
P3854[0...2]	<b>Condensation protection current [%]</b>	0 - 250	100	U, T	-	DDS	U16	2
	The DC current (as a percentage of nominal current) which is applied to the motor when condensation protection is active.							
<b>Dependency:</b>	See also P3852.							
P3900	<b>End of quick commissioning</b>	0 - 3	0	C(1)	-	-	U16	1
	Performs calculations necessary for optimized motor operation. After completion of calculation, P3900 and P0010 (parameter groups for commissioning) are automatically reset to their original value 0.							
	0	No quick commissioning						
	1	End quick commissioning with factory reset						
	2	End quick commissioning						
	3	End quick commissioning only for motor data						
<b>Dependency:</b>	Changeable only when P0010 = 1 (quick commissioning).							

7.2 Parameter list

Parameter	Function	Range	Factory default	Can be changed	Scaling	Data set	Data type	Acc. Level
<b>Note:</b>	<p>P3900 = 1: When setting 1 is selected, only the parameter settings carried out via the commissioning menu "Quick commissioning" are retained; all other parameter changes, including the I/O settings, are lost. Motor calculations are also performed.</p> <p>P3900 = 2: When setting 2 is selected, only those parameters, which depend on the parameters in the commissioning menu "Quick commissioning" (P0010 = 1) are calculated. The I/O settings are also reset to default and the motor calculations performed.</p> <p>P3900 = 3: When setting 3 is selected, only the motor and controller calculations are performed. Exiting quick commissioning with this setting saves time (for example, if only motor rating plate data have been changed). Calculates a variety of motor parameters, overwriting previous values. These include P0344 (motor weight), P0350 (stator resistance), P2000 (reference frequency), P2002 (reference current). When transferring P3900, the inverter uses its processor to carry out internal calculations. Communications - both via USS as well as via the Fieldbus - are interrupted for the time that it takes to make these calculations. This can result in the following error messages at the connected SIMATIC S7 control (communications via Fieldbus):</p> <ul style="list-style-type: none"> <li>• Parameter fault 30</li> <li>• Inverter fault 70</li> <li>• Inverter fault 75</li> </ul>							
r3930[0...4]	<b>Inverter data version</b>	-	-	-	-	-	U16	3
	Displays the A5E number and the inverter data versions.							
<b>Index:</b>	[0]	A5E 1st 4 digits						
	[1]	A5E 2nd 4 digits						
	[2]	Logistic Version						
	[3]	Fixed Data Version						
	[4]	Calib Data Version						
P3950	<b>Access of hidden parameters</b>	0 - 255	0	U, T	-	-	U16	4
	Accesses special parameters for development (expert only) and factory functionality (calibration parameter).							
r3954[0...12]	<b>CM info and GUI ID</b>	-	-	-	-	-	U16	4
	Used to classify firmware (only for SIEMENS internal purposes).							
<b>Index:</b>	[0]	CM label (increment / branch)						
	[1]	CM label (counter)						
	[2]	CM label						
	[3...10]	GUI ID						
	[11]	GUI ID major release						
	[12]	GUI ID minor release						
r3978	<b>BICO counter</b>	-	-	-	-	-	U32	4
	Counts the number of changed BICO links.							
P3981	<b>Reset active fault</b>	0 - 1	0	T	-	-	U16	4
	Resets active faults when changed from 0 to 1.							

Parameter	Function	Range	Factory default	Can be changed	Scaling	Data set	Data type	Acc. Level
	0	No fault reset						
	1	Reset fault						
<b>Note:</b>	See P0947 (last fault code) Automatically reset to 0.							
P3984	<b>Client telegram off time [ms]</b>	100 - 10000	1000	T	-	-	U16	3
	Defines time after which a fault will be generated (F73) if no telegram is received from the client.							
<b>Dependency:</b>	Setting 0 = watchdog disabled							
r3986[0...1]	<b>Number of parameters</b>	-	-	-	-	-	U16	4
	Number of parameters on the inverter.							
<b>Index:</b>	[0]	Read only						
	[1]	Read & write						
P7844	<b>Acceptance Test, Confirmation</b>	0 - 2	0	T	-	-	U16	3
	After an automatic download from MMC at startup, this parameter will be automatically set to 1. Also a fault F395 will be set. With setting to P7844 = 0 you quit F395 and confirm the parameter settings. Setting this parameter to 2 is only possible if an automatic download has been performed at startup. In this case the download will be undone and the previously stored parameters will be enabled.							
	0	Acceptance Test / Confirmation ok.						
	1	Acceptance Test / Confirmation is pending						
	2	Undo Clone						
<b>Note:</b>	If no automatic download from MMC has been performed during startup the setting 2 is not possible.							
P8458	<b>Clone control</b>	0 - 2	2	C, T	-	-	U16	3
	This parameter specifies whether a cloning at startup will be performed. The File clone00.bin will be used. If no MMC is inserted there will be a normal startup.							
	0	No Startup Clone						
	1	Once Startup Clone						
	2	Always Startup Clone						
<b>Note:</b>	Default value is 2. After first cloning the parameter is set to 0. If a MMC is inserted without a valid file the inverter will set a fault F61 / F63 / F64 which can only be cleared by a power-cycle. The fault is signaled by a flashing RUN LED (Commissioning). The SF LED is not activated. P8458 will not be changed by performing a factory reset.							
P8553	<b>Menu type</b>	0 - 1	0	U, T	-	-	U16	1
	Selects whether to have menus with no text or menus with some text on the BOP.							
	0	Menus with no text						
	1	Menus with some text						



# Faults and alarms

---

## Note







If there are multiple active faults and alarms, the BOP first displays all faults one after another. Once all faults are displayed, it displays all alarms in succession.

---

## 8.1 Faults

Immediately when a fault occurs the fault icon  shows and the display transitions to the faults screen. The faults screen displays the fault number preceded by "F".

### Acknowledging/clearing faults

- To navigate through the current list of faults, press  or .
- To view the inverter status at fault, press  (> 2 s); to return to the fault code display, press  (< 2 s).
- To clear/acknowledge the fault, press  or acknowledge externally if the inverter has been set up so; to ignore the fault, press .

After you acknowledge or ignore the fault, the screen returns to the previous display. The fault icon remains active until the fault is cleared/acknowledged.

---

## Note

Under the following circumstances, the faults screen displays again:

- If the fault has not been cleared and the  button is pressed, the faults screen displays again.
- If there is no key press for 60 seconds.

If a fault is active and there has been no key press for 60 seconds, the backlight (P0070) flashes.

---

Viewing inverter status at fault

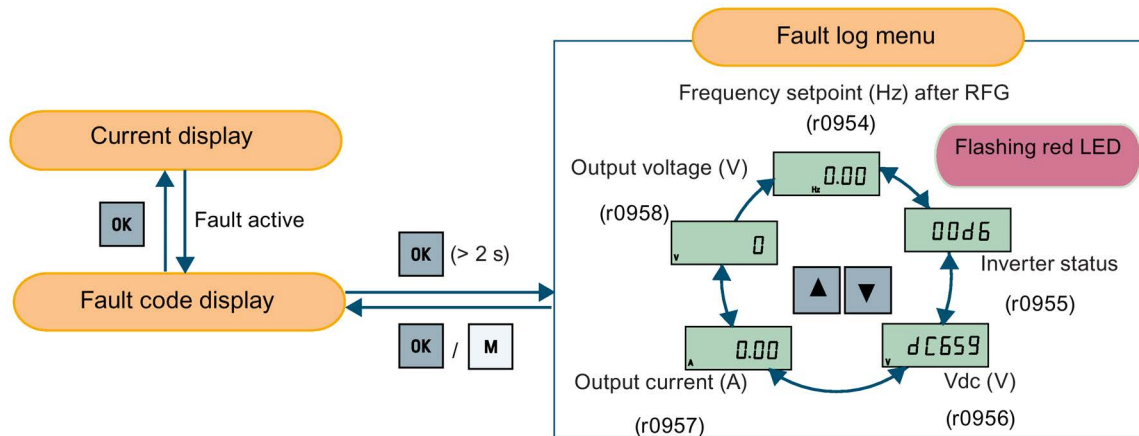

Fault code list

Fault	Cause	Remedy
<p><b>F1</b> Overcurrent</p>	<ul style="list-style-type: none"> <li>Motor power (P0307) does not correspond to the inverter power (r0206).</li> <li>Motor lead short circuit</li> <li>Earth faults</li> </ul> <p>r0949 = 0: Hardware reported                      r0949 = 1: Software reported                      r0949 = 22: Hardware reported</p>	<p>Check the following:</p> <ul style="list-style-type: none"> <li>Motor power (P0307) must correspond to inverter power (r0206).</li> <li>Cable length limits must not be exceeded.</li> <li>Motor cable and motor must have no short-circuits or earth faults.</li> <li>Motor parameters must match the motor in use.</li> <li>Value of stator resistance (P0350) must be correct.</li> <li>Motor must not be obstructed or overloaded.</li> <li>Increase ramp-up time (P1120)</li> <li>Reduce starting boost level (P1312)</li> </ul>
<p><b>F2</b> Overvoltage</p>	<ul style="list-style-type: none"> <li>Main supply voltage too high</li> <li>Motor is in regenerative mode</li> </ul> <p>r0949 = 0: Hardware reported                      r0949 = 1 or 2: Software reported</p>	<p>Check the following:</p> <ul style="list-style-type: none"> <li>Supply voltage (P0210) must lie within limits indicated on rating plate.</li> <li>Ramp-down time (P1121) must match inertia of load.</li> <li>Required braking power must lie within specified limits.</li> <li>Vdc controller must be enabled (P1240) and parameterized properly.</li> </ul> <p><b>Note:</b>                      Regenerative mode can be caused by fast ramp downs or if the motor is driven by an active load. Higher inertia requires longer ramp times; otherwise, apply braking resistor.</p>

Fault	Cause	Remedy
<b>F3</b> Undervoltage	<ul style="list-style-type: none"> <li>Main supply failed.</li> <li>Shock load outside specified limits.</li> </ul> r0949 = 0: Hardware reported r0949 = 1 or 2: Software reported	Check supply voltage.
<b>F4</b> Inverter overtemperature	<ul style="list-style-type: none"> <li>Inverter overloaded</li> <li>Ventilation inadequate</li> <li>Pulse frequency too high</li> <li>Surrounding temperature too high</li> <li>Fan inoperative</li> </ul>	Check the following: <ul style="list-style-type: none"> <li>Load or load cycle too high?</li> <li>Motor power (P0307) must match inverter power (r0206)</li> <li>Pulse frequency must be set to default value</li> <li>Surrounding temperature too high?</li> <li>Fan must turn when inverter is running</li> </ul>
<b>F5</b> Inverter I <sup>2</sup> t	<ul style="list-style-type: none"> <li>Inverter overloaded.</li> <li>Load cycle too demanding.</li> <li>Motor power (P0307) exceeds inverter power capability (r0206).</li> </ul>	Check the following: <ul style="list-style-type: none"> <li>Load cycle must lie within specified limits.</li> <li>Motor power (P0307) must match inverter power (r0206)</li> </ul> <b>Note:</b> F5 cannot be cleared until the inverter overload utilization (r0036) is lower than the inverter I <sup>2</sup> t warning (P0294).
<b>F6</b> Chip temperature rise exceeds critical levels	<ul style="list-style-type: none"> <li>Load at start-up is too high</li> <li>Load step is too high</li> <li>Ramp-up rate is too fast</li> </ul>	Check the following: <ul style="list-style-type: none"> <li>Load or load step too high?</li> <li>Increase ramp-up time (P1120).</li> <li>Motor power (P0307) must match inverter power (r0206).</li> <li>Use setting P0290 = 0 or 2 for preventing F6.</li> </ul>
<b>F11</b> Motor overtemperature	<ul style="list-style-type: none"> <li>Motor overloaded</li> </ul>	Check the following: <ul style="list-style-type: none"> <li>Load or load step too high?</li> <li>Motor nominal overtemperatures (P0626 - P0628) must be correct</li> <li>Motor temperature warning level (P0604) must match</li> </ul>
	<ul style="list-style-type: none"> <li>This fault may occur if small motors (<math>\leq 250</math> W, 4- or 2-pole) are used and run at a frequency below 15 Hz, even though the motor temperature is within limits.</li> </ul>	Check the following: <ul style="list-style-type: none"> <li>Motor current is not in excess of the motor nominal current as indicated by the motor rating plate</li> <li>Physical temperature of the motor lies within limits</li> </ul> If these two conditions are satisfied, then set parameter P0335 = 1.
<b>F12</b> Inverter temperature signal lost	Wire breakage of inverter temperature (heat sink) sensor.	

8.1 Faults

Fault	Cause	Remedy
<b>F20</b> DC ripple too high	The calculated DC ripple level has exceeded the safe threshold. This is commonly caused by loss of one of the mains input phases.	Check the mains supply wiring.
<b>F35</b> Maximum number of auto restart attempts exceeded	Auto restart attempts exceed value of P1211.	
<b>F41</b> Motor data identification failure	Motor data identification failed. <ul style="list-style-type: none"> <li>• r0949 = 0: No load applied</li> <li>• r0949 = 1: Current limit level reached during identification.</li> <li>• r0949 = 2: Identified stator resistance less than 0.1% or greater than 100%.</li> <li>• r0949 = 30: Current controller at voltage limit</li> <li>• r0949 = 40: Inconsistency of identified dataset, at least one identification failed</li> </ul> Percentage values based on the impedance $Z_b = V_{mot,nom} / \sqrt{3} / I_{mot,nom}$	Check the following: <ul style="list-style-type: none"> <li>• r0949 = 0: is the motor connected to the inverter?</li> <li>• r0949 = 1 - 49: are the motor data in P0304 - P0311 correct?</li> <li>• Check what type of motor wiring is required (star, delta).</li> </ul>
<b>F51</b> Parameter EEPROM fault	Read or write failure while access to EEPROM. This can also be caused by the EEPROM being full, too many parameters have been changed.	<ul style="list-style-type: none"> <li>• Must be power-cycled to cancel this bug as some parameters may not be read correct.</li> <li>• Factory reset and new parameterization, if power-cycle does not remove fault.</li> <li>• Change some parameters back to default values if the EEPROM is full, then power-cycle.</li> <li>• Change inverter.</li> </ul> <b>Note:</b> <ul style="list-style-type: none"> <li>• r0949 = 1: EEPROM full</li> <li>• r0949 = 1000 + block No: reading data block failed</li> <li>• r0949 = 2000 + block No: reading data block timeout</li> <li>• r0949 = 3000 + block No: reading data block CRC failed</li> <li>• r0949 = 4000 + block No: writing data block failed</li> <li>• r0949 = 5000 + block No: writing data block timeout</li> <li>• r0949 = 6000 + block No: writing data block verify failed</li> </ul>



Fault	Cause	Remedy
F51 (continued)		<ul style="list-style-type: none"> <li>• r0949 = 7000 + block No: reading data block at wrong time</li> <li>• r0949 = 8000 + block No: writing data block at wrong time</li> <li>• r0949 = 9000 + block No: factory reset did not work because restart or power failure</li> </ul>
F52 Inverter software fault	Read failure for inverter information or invalid data.	<p><b>Note:</b></p> <ul style="list-style-type: none"> <li>• r0949 = 1: Failed reading inverter identity</li> <li>• r0949 = 2: Inverter identity wrong</li> <li>• r0949 = 3: Failed reading inverter version</li> <li>• r0949 = 4: Inverter version wrong</li> <li>• r0949 = 5: Start of Part 1 inverter data wrong</li> <li>• r0949 = 6: Inverter number of temperature sensor wrong</li> <li>• r0949 = 7: Inverter number of application wrong</li> <li>• r0949 = 8: Start of Part 3 inverter data wrong</li> <li>• r0949 = 9: Reading inverter data string wrong</li> <li>• r0949 = 10: Inverter CRC failed</li> <li>• r0949 = 11: Inverter is blank</li> <li>• r0949 = 15: Failed CRC of inverter block 0</li> <li>• r0949 = 16: Failed CRC of inverter block 1</li> <li>• r0949 = 17: Failed CRC of inverter block 2</li> <li>• r0949 = 20: Inverter invalid</li> <li>• r0949 = 30: Directory size wrong</li> <li>• r0949 = 31: Directory ID wrong</li> <li>• r0949 = 32: Invalid block</li> <li>• r0949 = 33: File size wrong</li> <li>• r0949 = 34: Data section size wrong</li> <li>• r0949 = 35: Block section size wrong</li> <li>• r0949 = 36: RAM size exceeded</li> <li>• r0949 = 37: Parameter size wrong</li> <li>• r0949 = 38: Device header wrong</li> <li>• r0949 = 39: Invalid file pointer</li> <li>• r0949 = 40: Scaling block version wrong</li> <li>• r0949 = 41: Calibration block version wrong</li> <li>• r0949 = 50: Wrong serial number format</li> <li>• r0949 = 51: Wrong serial number format start</li> <li>• r0949 = 52: Wrong serial number format end</li> <li>• r0949 = 53: Wrong serial number format month</li> </ul>

8.1 Faults

Fault	Cause	Remedy
F52 (continued)		<ul style="list-style-type: none"> <li>• r0949 = 54: Wrong serial number format day</li> <li>• r0949 = 1000 + addr: Inverter read data failed</li> <li>• r0949 = 2000 + addr: Inverter write data failed</li> <li>• r0949 = 3000 + addr: Inverter read data wrong time</li> <li>• r0949 = 4000 + addr: Inverter write data wrong time</li> <li>• r0949 = 5000 + addr: Inverter read data invalid</li> <li>• r0949 = 6000 + addr: Inverter write data invalid</li> <li>• Power-cycle inverter</li> <li>• Contact service department or change inverter</li> </ul>
F60 Asic timeout	Internal communications failure.	<p>Check inverter. Fault appears sporadically:</p> <p><b>Note:</b></p> <ul style="list-style-type: none"> <li>• r0949 = 0: Hardware reported link fail</li> <li>• r0949 = 1: Software reported link fail</li> <li>• r0949 = 6: Feedback is not disabled for reading inverter data</li> <li>• r0949 = 7: During inverter download, message didn't transmit to disable feedback</li> <li>• Communication failure due to EMC problems</li> <li>• Check - and if necessary - improve EMC</li> <li>• Use EMC filter</li> </ul>
F61 MMC/SD card parameter cloning failed	<p>Parameter cloning failed.</p> <ul style="list-style-type: none"> <li>• r0949 = 0: MMC/SD card not connected or incorrect card type or the card failed to initialize for automatic cloning</li> <li>• r0949 = 1: Inverter data cannot write to the card.</li> <li>• r0949 = 2: Parameter cloning file not available</li> <li>• r0949 = 3: The MMC/SD card cannot read the file</li> <li>• r0949 = 4: Reading data from the clone file failed (e.g., reading failed, data or checksum wrong)</li> </ul>	<ul style="list-style-type: none"> <li>• r0949 = 0: Use an MMC/SD card with FAT16 or FAT32 format , or fit an MMC/SD card to the inverter.</li> <li>• r0949 = 1: Check the MMC/SD card (e.g., is the card memory full?) - format the card again to FAT16 or FAT32.</li> <li>• r0949 = 2: Put the correct named file in the correct directory /USER/SINAMICS/DATA.</li> <li>• r0949 = 3: Make sure file is accessible - recreate file if possible.</li> <li>• r0949 = 4: File has been changed - recreate file.</li> </ul>
F62 Parameter cloning contents invalid	File exists but the contents are not valid control word corruption.	Recopy and ensure operation completes.
F63 Parameter cloning contents incompatible	File exists but was not the correct inverter type.	Ensure clone from compatible inverter type.

Fault	Cause	Remedy
<b>F64</b> Inverter attempted to do an automatic clone during startup	No Clone00.bin file in the correct directory /USER/SINAMICS/DATA.	If an automatic clone is required: <ul style="list-style-type: none"> <li>• Insert the MMC/SD card with correct file and power-cycle.</li> </ul> If no automatic clone is required: <ul style="list-style-type: none"> <li>• Remove the card if not needed and power-cycle.</li> <li>• Reset P8458 = 0 and power-cycle.</li> </ul> <b>Note:</b> Fault can only be cleared by a power-cycle.
<b>F71</b> USS setpoint fault	No setpoint values from USS during telegram off time	Check USS master
<b>F72</b> USS/MODBUS setpoint fault	No setpoint values from USS/MODBUS during telegram off time	Check USS/MODBUS master
<b>F80</b> Signal lost on analog input	<ul style="list-style-type: none"> <li>• Broken wire</li> <li>• Signal out of limits</li> </ul>	
<b>F85</b> External fault	External fault triggered via command input via control word 2, bit 13.	<ul style="list-style-type: none"> <li>• Check P2106.</li> <li>• Disable control word 2 bit 13 as command source.</li> <li>• Disable terminal input for fault trigger.</li> </ul>
<b>F100</b> Watchdog reset	Software Error	Contact service department or change inverter.
<b>F101</b> Stack overflow	Software error or processor failure.	Contact service department or change inverter.
<b>F221</b> PID feedback below minimum value	PID feedback below minimum value P2268.	<ul style="list-style-type: none"> <li>• Change value of P2268.</li> <li>• Adjust feedback gain.</li> </ul>
<b>F222</b> PID feedback above maximum value	PID feedback above maximum value P2267.	<ul style="list-style-type: none"> <li>• Change value of P2267.</li> <li>• Adjust feedback gain.</li> </ul>
<b>F350</b> Configuration vector for the inverter failed	<p>During startup the inverter checks if the configuration vector (SZL vector) has been programmed correctly and if hardware matches the programmed vector. If not the inverter will trip.</p> <ul style="list-style-type: none"> <li>• r0949 = 1: Internal failure - no hardware configuration vector available.</li> <li>• r0949 = 2: Internal failure - no software configuration vector available.</li> <li>• r0949 = 11: Internal failure - inverter code not supported.</li> <li>• r0949 = 12: Internal failure - software vector not possible.</li> </ul>	<p>Internal failures cannot be fixed.</p> <p>r0949 = 13 - Make sure the right power module is fitted.</p> <b>Note:</b> Fault needs power-cycle to be acknowledged.

8.1 Faults

Fault	Cause	Remedy
<p><b>F350 (continued)</b></p>	<ul style="list-style-type: none"> <li>• r0949 = 13: Wrong power module fitted.</li> <li>• r0949 &gt; 1000: Internal failure - wrong I/O board fitted.</li> </ul>	
<p><b>F395</b> Acceptance test/confirmation pending</p>	<p>This fault occurs after a startup clone. It can also be caused by a faulty read from the EEPROM, see F51 for more details.</p> <p>A startup clone could have changed and might not match the application. This parameter set needs to be checked before the inverter can start a motor.</p> <ul style="list-style-type: none"> <li>• r0949 = 3/4: Inverter data change</li> <li>• r0949 = 5: Startup clone via an MMC/SD card has been performed</li> <li>• r0949 = 10: Previous startup clone was aborted</li> </ul>	<p>The current parameter set needs to be checked and confirmed by clearing the fault.</p>
<p><b>F410</b> Cavitation protection failure</p>	<p>Conditions exist for cavitation damage. Cavitation damage is damage caused to a pump in pumping systems when the fluid is not flowing sufficiently. This can lead to heat build up and subsequent damage to the pump.</p>	<p>If cavitation is not occurring, reduce the cavitation threshold P2361, or increase the cavitation protection delay. Ensure sensor feedback is working.</p>
<p><b>F452</b> Load monitoring trip</p>	<p>Load conditions on motor indicate belt failure or mechanical fault.</p> <ul style="list-style-type: none"> <li>• r0949 = 0: trip low torque / speed</li> <li>• r0949 = 1: trip high torque / speed</li> </ul>	<p>Check the following:</p> <ul style="list-style-type: none"> <li>• No breakage, seizure or obstruction of inverter train.</li> <li>• Apply lubrication if required.</li> </ul> <p>If using an external speed sensor, check the following parameters for correct function:</p> <ul style="list-style-type: none"> <li>- P2192 (delay time for permitted deviation)</li> <li>- P2182 (threshold frequency f1)</li> <li>- P2183 (threshold frequency f2)</li> <li>- P2184 (threshold frequency f3)</li> </ul> <p>If using a specific torque / speed range, check parameters:</p> <ul style="list-style-type: none"> <li>- P2182 (threshold frequency 1)</li> <li>- P2183 (threshold frequency 2)</li> <li>- P2184 (threshold frequency 3)</li> <li>- P2185 (upper torque threshold 1)</li> <li>- P2186 (lower torque threshold 1)</li> <li>- P2187 (upper torque threshold 2)</li> <li>- P2188 (lower torque threshold 2)</li> <li>- P2189 (upper torque threshold 3)</li> <li>- P2190 (lower torque threshold 3)</li> <li>- P2192 (delay time for permitted deviation)</li> </ul>

## 8.2 Alarms

If an alarm is activated the alarm icon ▲ shows immediately and then the display shows the alarm code preceded by "A".

### Note

Note that alarms cannot be acknowledged. They are cleared automatically once the warning has been rectified.

### Alarm code list

Alarm	Cause	Remedy
<b>A501</b> Current limit	<ul style="list-style-type: none"> <li>Motor power does not correspond to the inverter power</li> <li>Motor leads are too long</li> <li>Earth faults</li> </ul>	See F1.
	<ul style="list-style-type: none"> <li>Small motors (120 W) under FCC and light load may cause a high current</li> </ul>	Use V/f operation for very small motors
<b>A502</b> Overvoltage limit	Overvoltage limit is reached. This warning can occur during ramp down, if the Vdc controller is disabled (P1240 = 0).	If this warning is displayed permanently, check inverter input voltage.
<b>A503</b> Undervoltage limit	<ul style="list-style-type: none"> <li>Main supply failed.</li> <li>Main supply and consequently DC-link voltage (r0026) below specified limit.</li> </ul>	Check main supply voltage.
<b>A504</b> Inverter overtemperature	Warning level of inverter heat sink temperature, warning level of chip junction temperature, or allowed change in temperature on chip junction is exceeded, resulting in pulse frequency reduction and / or output frequency reduction (depending on parameterization in P0290).	<b>Note:</b> r0037[0]: Heat sink temperature r0037[1]: Chip junction temperature (includes heat sink) Check the following: <ul style="list-style-type: none"> <li>Surrounding temperature must lie within specified limits</li> <li>Load conditions and load steps must be appropriate</li> <li>Fan must turn when inverter is running</li> </ul>
<b>A505</b> Inverter I <sup>2</sup> t	Warning level exceeded, current will be reduced if parameterized (P0610 = 1).	Check that load cycle lies within specified limits.
<b>A506</b> IGBT junction temperature rise warning	Overload warning. Difference between heat sink and IGBT junction temperature exceeds warning limits.	Check that load steps and shock loads lie within specified limits.
<b>A507</b> Inverter temperature signal lost	Inverter heat sink temperature signal loss. Possible sensor fallen off.	Contact service department or change inverter.

8.2 Alarms

Alarm	Cause	Remedy
<b>A511</b> Motor overtemperature $I^2t$	<ul style="list-style-type: none"> <li>Motor overloaded.</li> <li>Load cycles or load steps too high.</li> </ul>	Independently of the kind of temperature determination check: <ul style="list-style-type: none"> <li>P0604 motor temperature warning threshold</li> <li>P0625 motor surrounding temperature</li> <li>Check if name plate data is correct. If not, perform quick commissioning. Accurate equivalent circuit data can be found by performing motor identification (P1900 = 2).</li> <li>Check if motor weight (P0344) is reasonable. Change if necessary.</li> <li>With P0626, P0627, and P0628 the standard overtemperature can be changed, If the motor is not a SIEMENS standard motor.</li> </ul>
<b>A535</b> Braking resistor over-load	The braking energy is too large. The braking resistor is not suited for the application.	Reduce the braking energy. Use a braking resistor with a higher rating.
<b>A541</b> Motor data identification active	Motor data identification (P1900) selected or running.	
<b>A600</b> RTOS overrun warning	Internal time slice overrun	Contact service department.
<b>A910</b> Vdc_max controller deactivated	Occurs <ul style="list-style-type: none"> <li>if main supply voltage (P0210) is permanently too high.</li> <li>if motor is driven by an active load, causing motor to go into regenerative mode.</li> <li>at very high load inertias, when ramping down.</li> </ul> If warning A910 occurs while the inverter is in standby (output pulses disabled) and an ON command is subsequently given, the Vdc_max controller (A911) will not be activated unless warning A910 is rectified.	Check the following: <ul style="list-style-type: none"> <li>Input voltage must lie within range.</li> <li>Load must be match.</li> <li>In certain cases apply braking resistor.</li> </ul>
<b>A911</b> Vdc_max controller active	The Vdc_max controller works to keep the DC-link voltage (r0026) below the level specified in r1242.	Check the following: <ul style="list-style-type: none"> <li>Supply voltage must lie within limits indicated on rating plate.</li> <li>Ramp-down time (P1121) must match inertia of load.</li> </ul> <b>Note:</b> Higher inertia requires longer ramp times; otherwise, apply braking resistor.

Alarm	Cause	Remedy
<b>A912</b> Vdc_min controller active	The Vdc_min controller will be activated if the DC-link voltage (r0026) falls below the level specified in r1246.  The kinetic energy of the motor is used to buffer the DC-link voltage, thus causing deceleration of the inverter! So short mains failures do not necessarily lead to an undervoltage trip.  Note that this warning may also occur on fast ramp-ups.	
<b>A921</b> Analog output parameters not set properly	Analog output parameters (P0777 and P0779) should not be set to identical values, since this would produce illogical results.	Check the following: <ul style="list-style-type: none"> <li>• Parameter settings for output identical</li> <li>• Parameter settings for input identical</li> <li>• Parameter settings for output do not correspond to analog output type</li> </ul> Set P0777 and P0779 to different values.
<b>A922</b> No load applied to inverter	No Load is applied to the inverter.  As a result, some functions may not work as under normal load conditions.	Check that motor is connected to inverter.
<b>A923</b> Both JOG left and JOG right are requested	Both JOG right and JOG left (P1055 / P1056) have been requested. This freezes the RFG output frequency at its current value.	Do not press JOG right and left simultaneously.
<b>A930</b> Cavitation protection warn	Conditions exist for possible cavitation damage.	See F410.
<b>A936</b> PID autotuning active	PID autotuning (P2350) selected or running	Warning disappears when PID autotuning has finished.
<b>A952</b> Load monitoring warning	Load conditions on motor indicate belt failure or mechanical fault.	See F452.





## Technical specifications

### Electrical specifications

#### Line supply characteristics

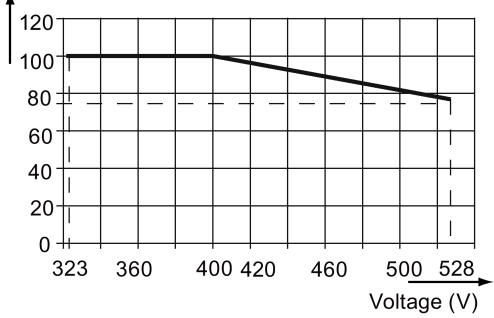
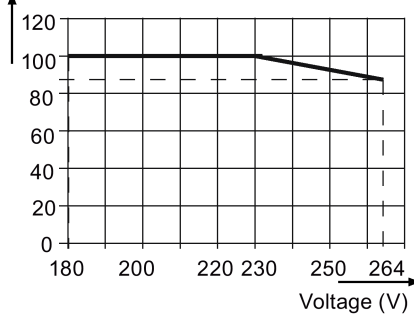
	Three phase AC 400 V inverters	Single phase AC 230 V inverters
Voltage range	380 V to 480 V AC (tolerance: -15% to +10%) 47 Hz to 63 Hz Current derating at high input voltages: Output current [%] 	200 V to 240 V AC (tolerance: -10% to +10%) 47 Hz to 63 Hz Current derating at high input voltages: Output current [%] 
	<b>Note:</b> For the current derating at 480 V at the default 4 kHz switching frequency and 40 °C surrounding air temperature, refer to the table in Section "Components of the inverter system (Page 21)".	
Overvoltage category	EN 60664-1 Category III	EN 60664-1 Category III
Permissible supply configuration	TN, TT, IT <sup>1)</sup> , TT earthed line	TN, TT
Supply environment	Second environment (private power network)	Second environment (private power network)

<sup>1)</sup> Note that only unfiltered variants can be operated on IT power system; to operate FSE filtered variant on IT power supply, make sure you remove the screw for the EMC filter.

#### Overload capability

Power rating (kW)	Average output current	Overload current	Maximum overload cycle
0.12 to 15	100% rated	150% rated for 60 seconds	150% rated for 60 seconds followed by 94.5% rated for 240 seconds
18.5 (HO)/22 (HO)			
22 (LO)/30 (LO)		110% rated for 60 seconds	110% rated for 60 seconds followed by more than 98% rated for 240 seconds

## EMC requirements

### Note

Install all inverters in accordance with the manufacturer's guidelines and in accordance with good EMC practices.

Use copper screened cable. For the maximum motor cable lengths, refer to Section "Terminal description (Page 40)".

Do not exceed the default switching frequency.

	Three phase AC 400 V inverters	Single phase AC 230 V inverters
ESD	EN 61800-3 Category C3	EN 61800-3 Category C3
Radiated immunity		
Burst		
Surge		
Conducted immunity		
Voltage distortion immunity		
Conducted emissions	Three phase AC 400 V filtered inverters:	Single phase AC 230 V filtered inverters:
Radiated emissions	EN 61800-3 Category C3	EN 61800-3 Category C2

## Maximum power losses

Three phase AC 400 V inverters																
Frame size	FSA						FSB		FS C	FSD			FSE		FSE	
Power rating (kW)	0.37	0.55	0.75	1.1	1.5	2.2	3.0	4.0	5.5	7.5	11	15	18.5		22	
													(H O)	(LO )	(H O)	(LO )
Maximum power loss (w) 1)	25	28	33	43	54	68	82	100	145	180	276	338	38 7	475	45 7	626
Single phase AC 230 V inverters																
Frame size	FSA						FSB		FSC							
Power rating (kW)	0.12	0.25	0.37	0.55	0.75	1.1	1.5	2.2	3.0							
Maximum power loss (w) 1)	14	22	29	39	48	72	95	138	177							

1) With I/O fully loaded

### Note

Power losses are given for nominal supply voltage, default switching frequency, and rated output current. Changing these factors may result in increased power losses.

## Harmonic currents

Single phase AC 230 V inverters	Typical harmonic current (% of rated input current) at U <sub>k</sub> 1%										
	3rd	5th	7th	9th	11th	13th	17th	19th	23rd	25th	29th
Frame size A	42	40	37	33	29	24	15	11	4	2	1
Frame size B	49	44	37	29	21	13	2	1	2	2	0
Frame size C	54	44	31	17	6	2	7	6	2	0	0

### Note

Units installed within the category C2 (domestic) environment require supply authority acceptance for connection to the public low-voltage power supply network. Please contact your local supply network provider.

## Output current deratings at different PWM frequencies and surrounding air temperatures

Three phase AC 400 V inverters													
Frame size	Power rating [kW]	Current rating [A] at PWM frequency PWM frequency range: 2 kHz to 16 kHz (default: 4 kHz)											
		2 kHz			4 kHz			6 kHz			8 kHz		
		40 °C	50 °C	60 °C	40 °C	50 °C	60 °C	40 °C	50 °C	60 °C	40 °C	50 °C	60 °C
A	0.37	1.3	1.0	0.7	<b>1.3</b>	1.0	0.7	1.1	0.8	0.5	0.9	0.7	0.5
A	0.55	1.7	1.3	0.9	<b>1.7</b>	1.3	0.9	1.4	1.0	0.7	1.2	0.9	0.6
A	0.75	2.2	1.8	1.1	<b>2.2</b>	1.8	1.1	1.9	1.3	0.9	1.5	1.1	0.8
A	1.1	3.1	2.6	1.6	<b>3.1</b>	2.6	1.6	2.6	1.9	1.3	2.2	1.6	1.1
A	1.5	4.1	3.4	2.1	<b>4.1</b>	3.4	2.1	3.5	2.5	1.7	2.9	2.1	1.4
A	2.2	5.6	4.6	2.8	<b>5.6</b>	4.6	2.8	4.8	3.4	2.4	3.9	2.8	2.0
B	3.0	7.3	6.3	3.7	<b>7.3</b>	6.3	3.7	6.2	4.4	3.1	5.1	3.7	2.6
B	4.0	8.8	8.2	4.4	<b>8.8</b>	8.2	4.4	7.5	5.3	3.7	6.2	4.4	3.1
C	5.5	12.5	10.8	6.3	<b>12.5</b>	10.8	6.3	10.6	7.5	5.3	8.8	6.3	4.4
D	7.5	16.5	14.5	8.3	<b>16.5</b>	14.5	8.3	14.0	9.9	6.9	11.6	8.3	5.8
D	11	25.0	21.0	12.5	<b>25.0</b>	21.0	12.5	21.3	15.0	10.5	17.5	12.5	8.8
D	15	31.0	28.0	15.5	<b>31.0</b>	28.0	15.5	26.4	18.6	13.0	21.7	15.5	10.9
E	18.5 (HO)	38.0	34.5	19.0	<b>38.0</b>	34.5	19.0	32.3	22.8	16.0	26.6	19.0	13.3
E	22 (LO)	45.0	40.5	22.5	<b>45.0</b>	40.5	22.5	38.3	27.0	18.9	31.5	22.5	15.8
E	22 (HO)	45.0	40.5	22.5	<b>45.0</b>	40.5	22.5	38.3	27.0	18.9	31.5	22.5	15.8
E	30 (LO)	60.0	53.0	30.0	<b>60.0</b>	53.0	30.0	51.0	36.0	25.2	42.0	30.0	21.0
		10 kHz			12 kHz			14 kHz			16 kHz		
		40 °C	50 °C	60 °C	40 °C	50 °C	60 °C	40 °C	50 °C	60 °C	40 °C	50 °C	60 °C
A	0.37	0.8	0.5	0.4	0.7	0.5	0.3	0.6	0.4	0.3	0.5	0.4	0.3
A	0.55	1.0	0.7	0.5	0.9	0.6	0.4	0.8	0.5	0.4	0.7	0.5	0.3
A	0.75	1.3	0.9	0.7	1.1	0.8	0.6	1.0	0.7	0.5	0.9	0.6	0.4
A	1.1	1.9	1.3	0.9	1.6	1.1	0.8	1.4	1.0	0.7	1.2	0.9	0.6
A	1.5	2.5	1.7	1.2	2.1	1.4	1.0	1.8	1.3	0.9	1.6	1.1	0.8
A	2.2	3.4	2.4	1.7	2.8	2.0	1.4	2.5	1.7	1.2	2.2	1.6	1.1
B	3.0	4.4	3.1	2.2	3.7	2.6	1.8	3.3	2.3	1.6	2.9	2.0	1.5

Three phase AC 400 V inverters													
Frame size	Power rating [kW]	Current rating [A] at PWM frequency											
		PWM frequency range: 2 kHz to 16 kHz (default: 4 kHz)											
B	4.0	5.3	3.7	2.6	4.4	3.1	2.2	4.0	2.7	1.9	3.5	2.5	1.8
C	5.5	7.5	5.3	3.8	6.3	4.4	3.1	5.6	3.9	2.8	5.0	3.5	2.5
D	7.5	9.9	6.9	5.0	8.3	5.8	4.1	7.4	5.1	3.6	6.6	4.6	3.3
D	11	15.0	10.5	7.5	12.5	8.8	6.3	11.3	7.8	5.5	10.0	7.0	5.0
D	15	18.6	13.0	9.3	15.5	10.9	7.8	14.0	9.6	6.8	12.4	8.7	6.2
E	18.5 (HO)	22.8	16.0	11.4	19.0	13.3	9.5	17.1	11.8	8.4	15.2	10.6	7.6
E	22 (LO)	27.0	18.9	13.5	22.5	15.8	11.3	20.3	14.0	9.9	18.0	12.6	9.0
E	22 (HO)	27.0	18.9	13.5	22.5	15.8	11.3	20.3	14.0	9.9	18.0	12.6	9.0
E	30 (LO)	36.0	25.2	18.0	30.0	21.0	15.0	27.0	18.6	13.2	24.0	16.8	12.0

Single phase AC 230 V inverters													
Frame size	Power rating [kW]	Current rating [A] at PWM frequency											
		PWM frequency range: 2 kHz to 16 kHz (default: 8 kHz)											
		2 kHz			4 kHz			6 kHz			8 kHz		
		40 °C	50 °C	60 °C	40 °C	50 °C	60 °C	40 °C	50 °C	60 °C	40 °C	50 °C	60 °C
A	0.12	0.9	0.6	0.5	0.9	0.6	0.5	0.9	0.6	0.5	0.9	0.6	0.5
A	0.25	1.7	1.2	0.9	1.7	1.2	0.9	1.7	1.2	0.9	1.7	1.2	0.9
A	0.37	2.3	1.6	1.2	2.3	1.6	1.2	2.3	1.6	1.2	2.3	1.6	1.2
A	0.55	3.2	2.2	1.6	3.2	2.2	1.6	3.2	2.2	1.6	3.2	2.2	1.6
A	0.75	3.9	2.7	2.0	3.9	2.7	2.0	3.9	2.7	2.0	3.9	2.7	2.0
A	0.75*	4.2	2.9	2.1	4.2	2.9	2.1	4.2	2.9	2.1	4.2	2.9	2.1
B	1.1	6.0	4.2	3.0	6.0	4.2	3.0	6.0	4.2	3.0	6.0	4.2	3.0
B	1.5	7.9	5.5	4.0	7.9	5.5	4.0	7.9	5.5	4.0	7.9	5.5	4.0
C	2.2	11	7.7	5.5	11	7.7	5.5	11	7.7	5.5	11	7.7	5.5
C	3.0	13.6	9.5	6.8	13.6	9.5	6.8	13.6	9.5	6.8	13.6	9.5	6.8
		10 kHz			12 kHz			14 kHz			16 kHz		
		40 °C	50 °C	60 °C	40 °C	50 °C	60 °C	40 °C	50 °C	60 °C	40 °C	50 °C	60 °C
A	0.12	0.8	0.6	0.4	0.8	0.5	0.4	0.7	0.5	0.3	0.6	0.5	0.3
A	0.25	1.6	1.1	0.8	1.4	1.0	0.7	1.3	0.9	0.6	1.2	0.9	0.6
A	0.37	2.1	1.5	1.1	2.0	1.4	1.0	1.7	1.2	0.9	1.6	1.2	0.8
A	0.55	2.9	2.0	1.5	2.7	1.9	1.3	2.4	1.7	1.2	2.2	1.6	1.1
A	0.75	3.6	2.5	1.8	3.3	2.3	1.6	2.9	2.0	1.4	2.7	2.0	1.4
A	0.75*	3.9	2.7	1.9	3.6	2.5	1.8	3.2	2.2	1.6	2.9	2.1	1.5
B	1.1	5.5	3.8	2.8	5.1	3.6	2.5	4.5	3.1	2.2	4.2	3.0	2.1
B	1.5	7.3	5.1	3.6	6.7	4.7	3.3	5.9	4.1	2.9	5.5	4.0	2.8
C	2.2	10.1	7.0	5.1	9.4	6.6	4.6	8.3	5.7	4.1	7.7	5.5	3.9
C	3.0	12.5	8.7	6.3	11.6	8.2	5.7	10.2	7.1	5.0	9.5	6.8	4.8

\* 230 V inverter frame size A with fan

## Motor control

Control methods	Linear V/F, quadratic V/F, multi-point V/F, V/F with FCC	
Output frequency range	Default range: 0 Hz to 550 Hz Resolution: 0.01 Hz	
Maximum over-load cycle	Rated power 0.12 kW to 15 kW	150 % rated for 60 seconds followed by 94.5 % rated for 240 seconds
	Rated power 18.5 kW (HO)/22 kW (HO)	
	Rated power 22 kW (LO)/30 kW (LO)	110% rated for 60 seconds followed by more than 98% rated for 240 seconds

## Mechanical specifications

		Frame size A		Frame size B	Frame size C	Frame size D <sup>1)</sup>	Frame size E
		with fan	without fan				
Outline dimensions (mm)	W	90	90	140	184	240	245
	H	166	150	160	182	206.5	264.5
	D	145.5	145.5 (114.5 <sup>2)</sup> )	164.5	169	172.5	209
Mounting methods		<ul style="list-style-type: none"> <li>Cabinet panel mounting (frame sizes A to E)</li> <li>Push-through mounting (frame sizes B to E)</li> </ul>					

1) Available for three phase AC 400 V inverters only.

2) Depth of Flat Plate inverter (400 V 0.75 kW variant only).





Frame size		Net weight (kg)		Gross weight (kg)	
		unfiltered	filtered	unfiltered	filtered
Three phase AC 400 V inverters					
A	with fan	1.0	1.1	1.4	1.4
	without fan	0.9	1.0 (0.9 <sup>1)</sup> )	1.3	1.4 (1.3 <sup>1)</sup> )
B		1.6	1.8	2.1	2.3
C		2.4	2.6	3.1	3.3
D	7.5 kW	3.7	4.0	4.3	4.6
	11 kW	3.7	4.1	4.5	4.8
	15 kW	3.9	4.3	4.6	4.9
E	18.5 kW	6.2	6.8	6.9	7.5
	22 kW	6.4	7.0	7.1	7.7
Single phase AC 230 V inverters					
A	with fan	1.1	1.2	1.4	1.5
	without fan	1.0	1.1	1.3	1.4
B		1.6	1.8	2.0	2.1
C		2.5	2.8	3.0	3.2

1) Weight of Flat Plate inverter (400 V 0.75 kW variant only).

**Environmental conditions**

Surrounding air temperature	0 °C to 40 °C: without derating 40 °C to 60 °C: with derating (UL/cUL-compliant: 40 °C to 50 °C: with derating)																					
Storage temperature	- 40 °C to + 70 °C																					
Protection class	IP 20																					
Maximum humidity level	95% (non-condensing)																					
Shock and vibration	Long-term storage in the transport packaging according to EN 60721-3-1 Class 1M2																					
	Transport in the transport packaging according to EN 60721-3-2 Class 2M3																					
	Vibration during operation according to EN 60721-3-3 Class 3M2																					
Operating altitude	Up to 4000 m above sea level 1000 m to 4000 m: output current derating 2000 m to 4000 m: input voltage derating																					
	<div style="display: flex; justify-content: space-around;"> <div style="text-align: center;"> <p>Permissible output current [%]</p> <table border="1"> <caption>Data for Permissible output current [%]</caption> <thead> <tr> <th>Installation altitude [m]</th> <th>Permissible output current [%]</th> </tr> </thead> <tbody> <tr><td>0</td><td>100</td></tr> <tr><td>1000</td><td>100</td></tr> <tr><td>2000</td><td>95</td></tr> <tr><td>3000</td><td>90</td></tr> <tr><td>4000</td><td>80</td></tr> </tbody> </table> </div> <div style="text-align: center;"> <p>Permissible input voltage [%]</p> <table border="1"> <caption>Data for Permissible input voltage [%]</caption> <thead> <tr> <th>Installation altitude [m]</th> <th>Permissible input voltage [%]</th> </tr> </thead> <tbody> <tr><td>0</td><td>100</td></tr> <tr><td>2000</td><td>100</td></tr> <tr><td>3000</td><td>85</td></tr> <tr><td>4000</td><td>77</td></tr> </tbody> </table> </div> </div>	Installation altitude [m]	Permissible output current [%]	0	100	1000	100	2000	95	3000	90	4000	80	Installation altitude [m]	Permissible input voltage [%]	0	100	2000	100	3000	85	4000
Installation altitude [m]	Permissible output current [%]																					
0	100																					
1000	100																					
2000	95																					
3000	90																					
4000	80																					
Installation altitude [m]	Permissible input voltage [%]																					
0	100																					
2000	100																					
3000	85																					
4000	77																					
Environmental classes	Pollution degree: 2 Solid particles: class 3S2 Chemical gases: class 3C2 (SO <sub>2</sub> , H <sub>2</sub> S) Climate class: 3K3																					
Minimum mounting clearance	Top: 100 mm Bottom: 100 mm (85 mm for fan-cooled frame size A) Side: 0 mm																					

## Standards

	<p><b>European Low Voltage Directive</b></p> <p>The SINAMICS V20 product range complies with the requirements of the Low Voltage Directive 2006/95/EC as amended by Directive 98/68/EEC. The units are certified for compliance with the following standards: EN 61800-5-1 — Semiconductor inverters – General requirements and line commutated inverters</p> <p><b>European EMC Directive</b></p> <p>When installed according to the recommendations described in this manual, the SINAMICS V20 fulfills all requirements of the EMC Directive as defined by the EMC Product Standard for Power Drive Systems EN 61800-3.</p>
	<p>UL certification (UL508C)/cUL (CSA C22.2 NO-14-10)</p>
	<p>The SINAMICS V20 complies with the appropriate C-tick EMC standard.</p>
	<p>The SINAMICS V20 complies with the appropriate EAC standard.</p>
	<p>The SINAMICS V20 complies with the Korean standards.</p> <p>For sellers or users, please keep in mind that this device is an A-grade electromagnetic wave device. This device is intended to be used in areas other than home.</p> <p><b>EMC limit values in South Korea</b></p> <p>The EMC limit values to be complied with for South Korea correspond to the limit values of the EMC product standard for variable-speed electric drives EN 61800-3, Category C2 or limit value class A, Group 1 according to EN55011. By applying suitable supplementary measures, the limit values according to Category C2 or according to limit value class A, Group 1 are maintained. Further, additional measures may be required, for instance, using an additional radio interference suppression filter (EMC filter). The measures for EMC-compliant design of the system are described in detail in this manual.</p> <p>Please note that the final statement on compliance with the standard is given by the respective label attached to the individual unit.</p>
<p>ISO 9001</p>	<p>Siemens plc operates a quality management system, which complies with the requirements of ISO 9001.</p>

Certificates can be downloaded from the internet under the following link:

Website for certificates

<http://support.automation.siemens.com/WW/view/en/60668840/134200>)





## Options and spare parts

### B.1 Options

For more information about recommended cable cross-sections and screw tightening torques, see the table "Recommended cable cross-sections and screw tightening torques" in Section "Terminal description (Page 40)".

---

#### Note

In order to gain access to the expansion port to fit the Parameter Loader or Bop Interface Module, remove the detachable transparent cover gently using just finger pressure. It is recommended to keep the cover in a safe place and refit it when the expansion port is not in use.

---

#### B.1.1 Parameter Loader

Order number: 6SL3255-0VE00-0UA0

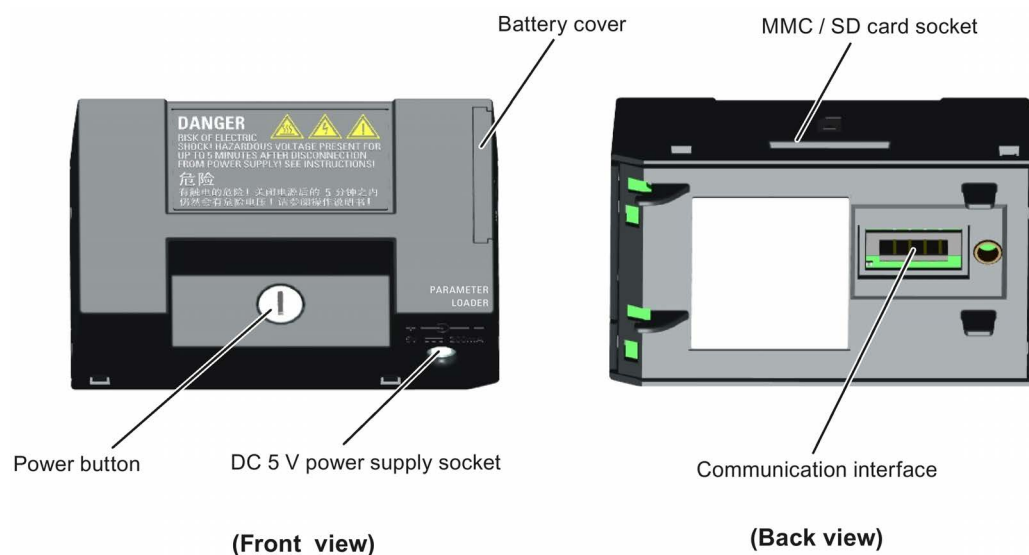

### Outline dimensions (mm)



### Functionality

The Parameter Loader provides the ability to upload/download parameter sets between the inverter and an MMC / SD card. It is only a commissioning tool and has to be removed during normal operation.

---

#### Note

To clone saved parameter settings from one inverter to another, a Parameter Loader is required. For detailed information about clone steps, see the data transferring steps described in this section.

During parameter cloning, make sure you either connect the PE terminal to earth or observe ESD protective measures.

---

#### MMC / SD card socket

The Parameter Loader contains an MMC/ SD card socket which is connected directly to the expansion port on the inverter.

#### Battery power supply

In addition to the memory card interface, the Parameter Loader can hold two batteries (consumer grade, non-rechargeable carbon-zinc or alkaline AA size batteries only) which allow the inverter to be powered directly from this option module when the mains power is not available. If the inverter can be supplied from the mains power, it is not necessary to power the Parameter Loader from the batteries.

#### DC 5 V power supply socket

The Parameter Loader contains a 5 V DC power supply socket for connection to an external Class 2 DC power supply. When mains power is not available to the inverter, it is possible to power the Parameter Loader from this DC supply rather than using batteries.

## Fitting the Parameter Loader to the inverter

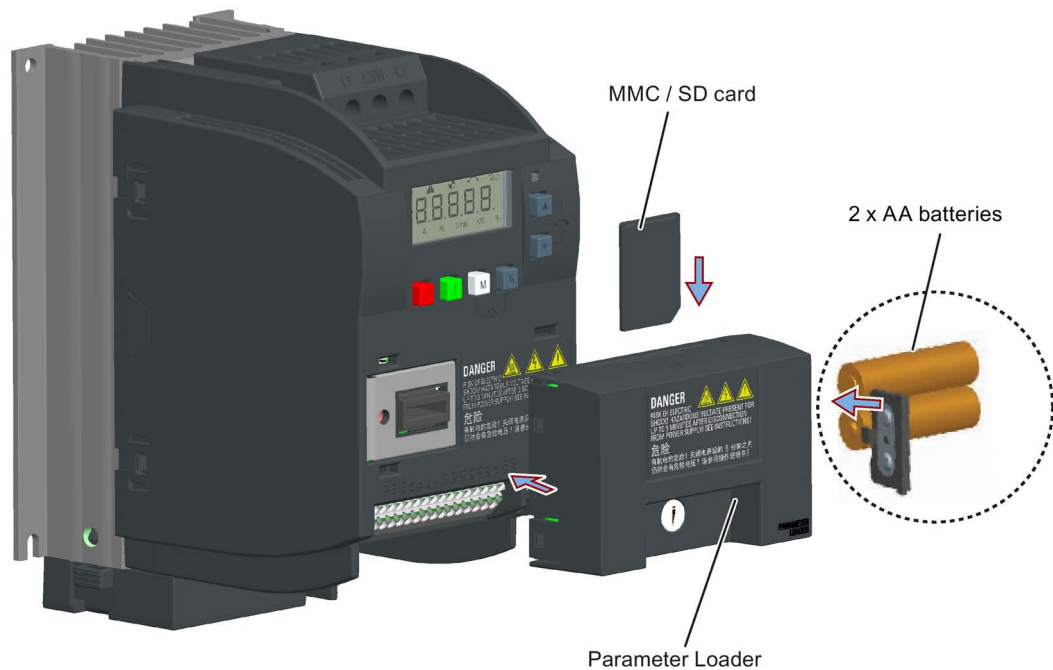

### Recommended MMC / SD cards

The following MMC / SD cards are recommended:

- MMC card (order number: 6SL3254-0AM00-0AA0)
- SD card (order number: 6SL3054-4AG00-2AA0)

### Using memory cards from other manufacturers

Requirements for MMC / SD cards:

- Supported file format: FAT16 and FAT 32
- Maximum card capacity: 2 GB
- Minimum card space for parameter transfer: 8 KB

---

#### Note

You use memory cards from other manufacturers at your own risk. Depending on the card manufacturer, not all functions are supported (e.g. download).

---

### Methods to power on the inverter

Use one of the following methods to power on the inverter for downloading / uploading parameters:

- Power on from the mains supply.
- Power on from the built-in battery power supply. Press the power button on the Parameter Loader and the inverter is powered on.
- Power on from an external DC 5 V power supply that is connected to the Parameter Loader. Press the power button on the Parameter Loader and the inverter is powered on.

### Transferring data from inverter to MMC / SD card

1. Fit the option module to the inverter.
2. Power on the inverter.
3. Insert the card into the option module.
4. Set P0003 (user access level) = 3.
5. Set P0010 (commissioning parameter) = 30.
6. Set P0804 (select clone file). This step is necessary only when the card contains the data files that you do not desire to be overwritten.

P0804 = 0 (default): file name is clone00.bin

P0804 = 1: file name is clone01.bin

...

P0804 = 99: file name is clone99.bin

7. Set P0802 (transfer data from inverter to card) = 2.

The inverter displays "8 8 8 8" during transfer and the LED is lit up orange and flashes at 1 Hz. After a successful transfer, both P0010 and P0802 are automatically reset to 0. If any faults occur during the transfer, see Chapter "Faults and alarms (Page 281)" for possible reasons and remedies.

### Transferring data from MMC / SD card to inverter

There are two ways to perform a data transfer.

#### Method 1:

**(Precondition: Inverter is to be powered up after inserting the card)**

1. Fit the option module to the inverter.
2. Insert the card into the option module. Make sure the card contains the file "clone00.bin".
3. Power on the inverter.

Data transfer starts automatically. Then the fault code F395 displays which means "Cloning has occurred. Do you want to keep the clone edits?".

4. To save the clone edits, press **OK** and the fault code is cleared. When the clone file is written to EEPROM, the LED is lit up orange and flashes at 1Hz.

If you do not wish to keep the clone edits, remove the card or the option module and restart the inverter. The inverter will power up with the fault code F395 and r0949 = 10 indicating that the previous cloning was aborted. To clear the fault code, press **OK**.

#### **Method 2:**

**(Precondition: Inverter is powered up before inserting the card)**

1. Fit the option module to the powered inverter.
2. Insert the card into the option module.
3. Set P0003 (user access level) = 3.
4. Set P0010 (commissioning parameter) = 30.
5. Set P0804 (select clone file). This step is necessary only when the card does not contain the file "clone00.bin". The inverter copies by default the file "clone00.bin" from the card.
6. Set P0803 (transfer data from card to inverter) = 2.

The inverter displays "8 8 8 8" during transfer and the LED is lit up orange and flashes at 1 Hz. After a successful transfer, both P0010 and P0803 are automatically reset to 0.

Note that fault code F395 only occurs with power-up cloning.

## **B.1.2 External BOP and BOP Interface Module**

### **External BOP**

Order number: 6SL3255-0VA00-4BA0

The external BOP is used for remote control of the inverter operation. When mounted on a suitable cabinet door, the external BOP can achieve a UL/cUL Type 1 enclosure rating.

#### **Components**

- External BOP unit
- 4 x M3 screws

### Rating plate

The rating plate for the external BOP is located on the back side of the BOP.

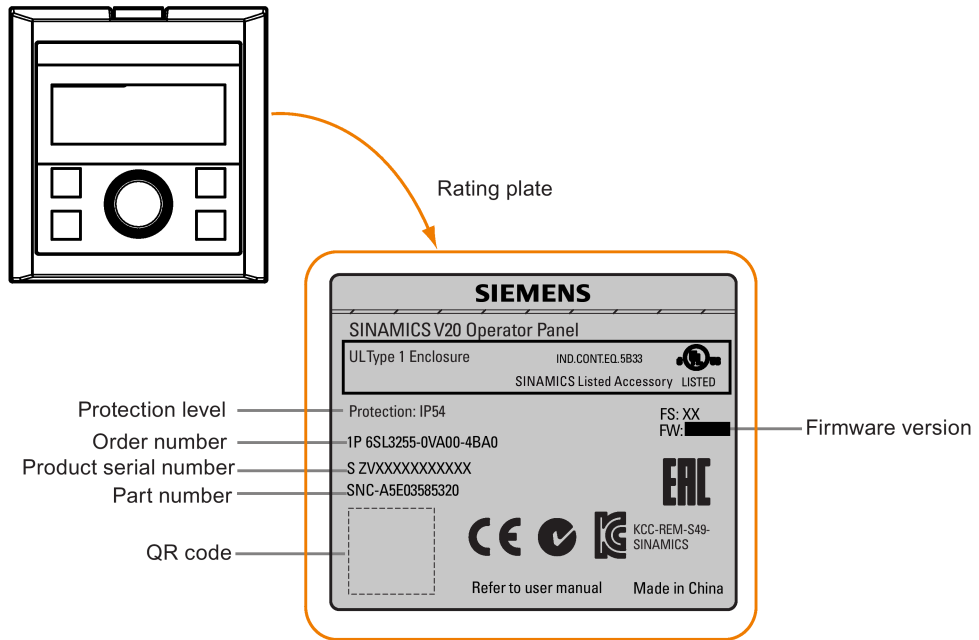





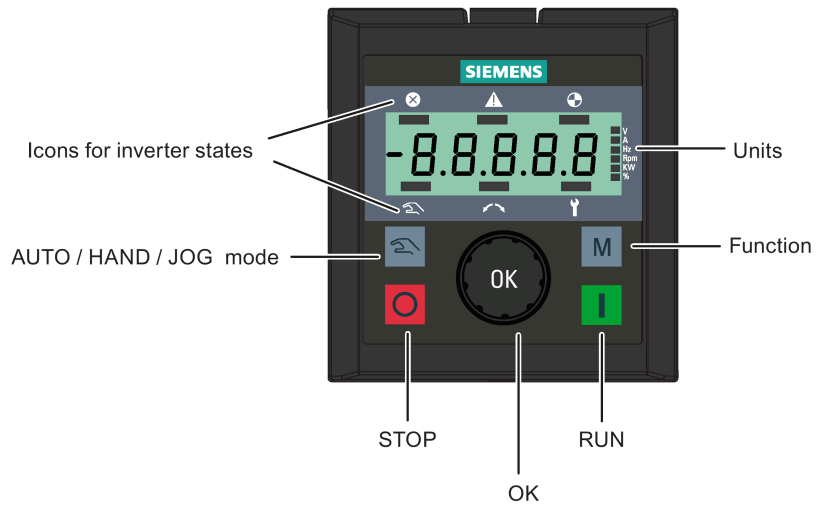









### Panel layout







The SINAMICS V20 supports an external BOP for remote control of inverter operation. The external BOP connects to the inverter through an optional BOP Interface Module.



### Button functions

Button	Description
	<b>Stops the inverter</b> Button functions the same as the  button on the built-in BOP.
	<b>Starts the inverter</b> Button functions the same as the  button on the built-in BOP.
	<b>Multi-function button</b> Button functions the same as the  button on the built-in BOP.
	<b>Pressing the button:</b> Button functions the same as the  button on the built-in BOP. <b>Turning clockwise:</b> Button functions the same as the  button on the built-in BOP. Fast turning functions the same as long press of the  button on the built-in BOP. <b>Turning counter-clockwise:</b> Button functions the same as the  button on the built-in BOP. Fast turning functions the same as long press of the  button on the built-in BOP.
	Button functions the same as the  +  buttons on the built-in BOP.

### Inverter status icons

	These icons have the same meaning as the corresponding icons on the built-in BOP.
	
	
	
	
	Commissioning icon. The inverter is in commissioning mode (P0010 = 1).

### Screen display

The display of the external BOP is identical to the built-in BOP, except that the external BOP has a commissioning icon  which is used to indicate that the inverter is in commissioning mode.

On inverter power-up, the inverter-connected external BOP first displays "BOP.20" (BOP for the SINAMICS V20) and then the firmware version of the BOP. After that it detects and displays the baudrate and the USS communication address of the inverter automatically.

See the following table for settable baudrate and address values. To change the baudrate, set P2010[0]. To change the USS communication address, set P2011[0].

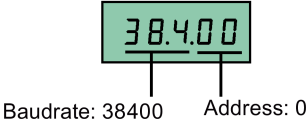
Baudrate (bps)	Communication address	Display example
9600	0 ... 31	
19200	0 ... 31	
38400	0 ... 31	
57600	0 ... 31	
76800	0 ... 31	
93750	0 ... 31	
115200	0 ... 31	

In case of any communication errors, the screen displays "noCon" which means that no communication connection has been detected. The inverter then automatically restarts baudrate and address detection. In this case, check that the cable is correctly connected.

**Mounting dimensions of the external BOP**

The outline dimensions, drill pattern and cut-out dimensions of the external BOP are shown below:

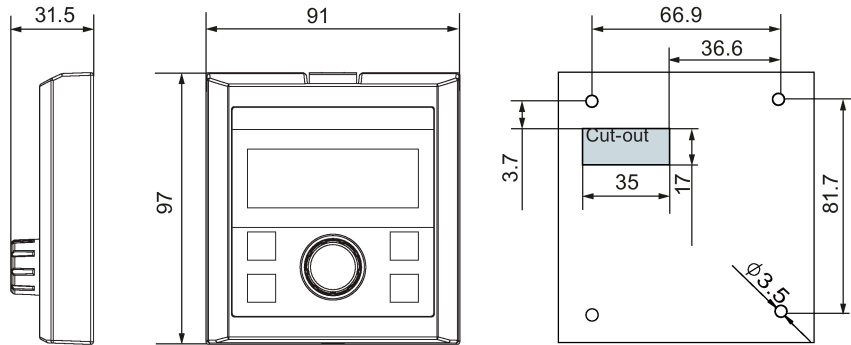

Unit: mm

Fixings:  
 4 x M3 screws (length: 12 mm to 18 mm)  
 Tightening torque: 0.8 Nm ± 10%



## BOP Interface Module

Order number: 6SL3255-0VA00-2AA0

### Functionality

This module can be used as an interface module for the external BOP, thus realizing the remote control over the inverter by the external BOP.

The module contains a communication interface for connecting the external BOP to the inverter and a plug connector for connection to the expansion port on the inverter.

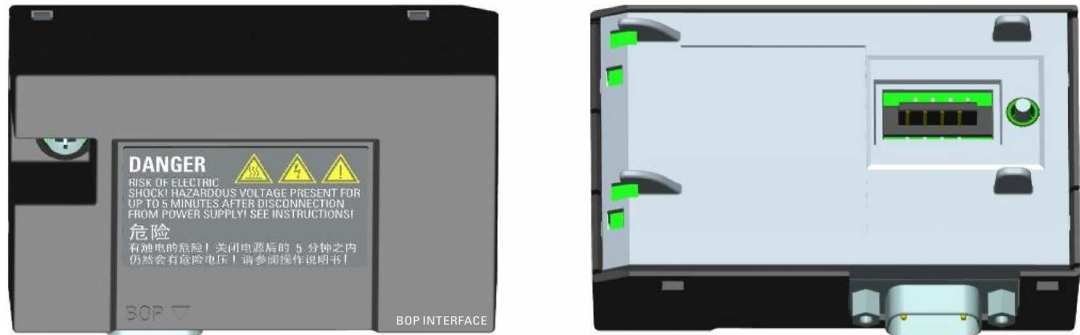

### Outline dimensions (mm)

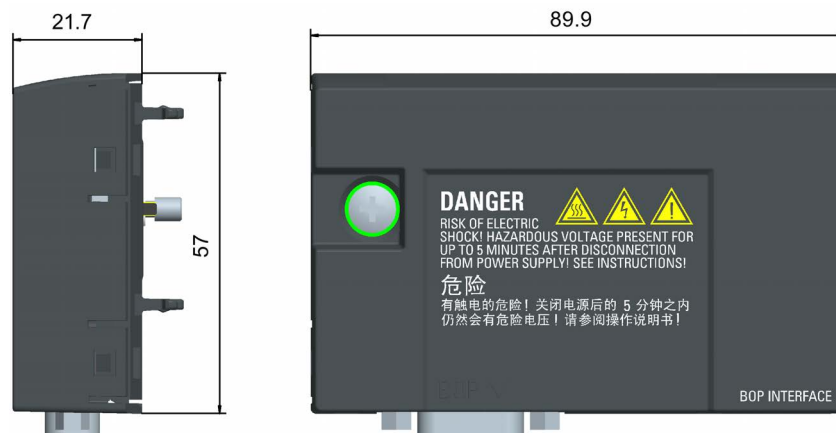

### Mounting (SINAMICS V20 + BOP Interface Module + external BOP)

#### Note

Connecting the BOP Interface Module to the external BOP is required only when you desire to control the inverter operation remotely with the external BOP. The BOP Interface Module needs to be screwed to the inverter with a tightening torque of 1.5 Nm (tolerance:  $\pm 10\%$ ).

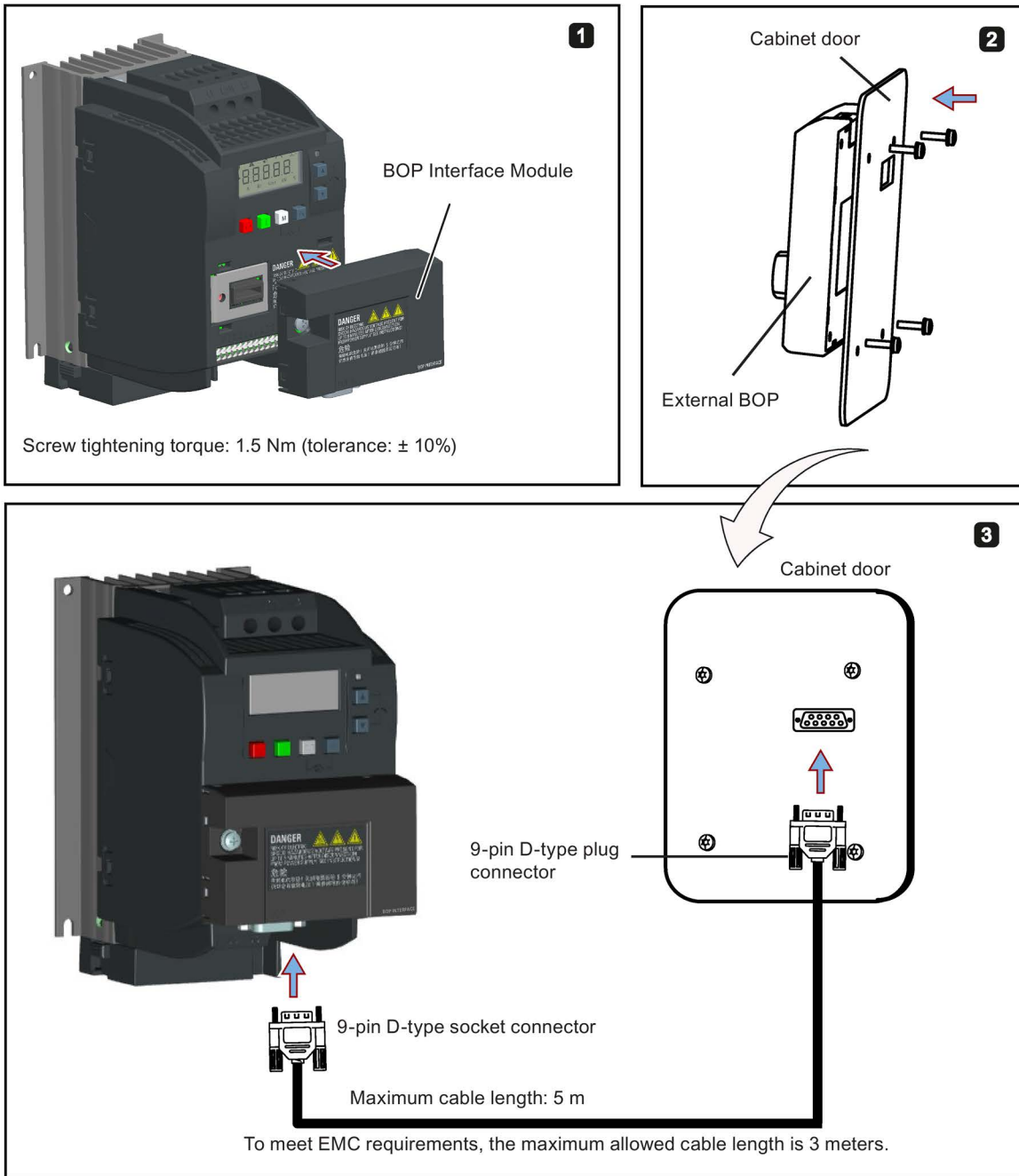

### B.1.3 Connecting cable (external BOP to BOP Interface Module)

Order number: 6SL3256-0VP00-0VA0

To: BOP Interface Module

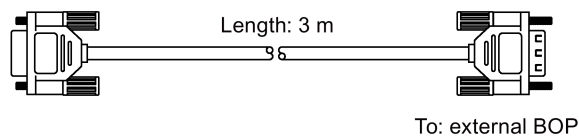

### Connecting the external BOP to the BOP interface module

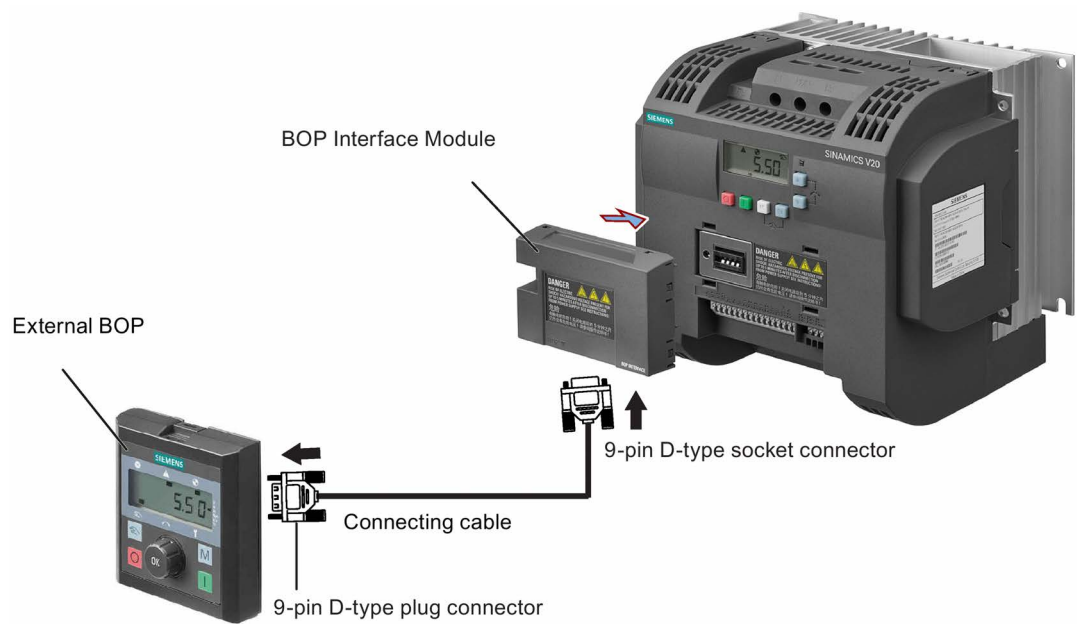

### B.1.4 Dynamic braking module

Order number: 6SL3201-2AD20-8VA0

---

#### Note

This module is applicable for frame sizes A to C only.

---

#### Functionality

The dynamic braking module is typically used in applications in which dynamic motor behavior is required at different speed or continuous direction changes, for example, for conveyor drives or hoisting gear.

Dynamic braking converts the regenerative energy, which is released when the motor brakes, into heat. Dynamic braking activity is limited by the duty cycle selected with the control knob.

#### Mounting orientation

The dynamic braking module must be installed in the orientation as shown in the following diagram. That is, the open slots must always point directly upwards to ensure adequate cooling.

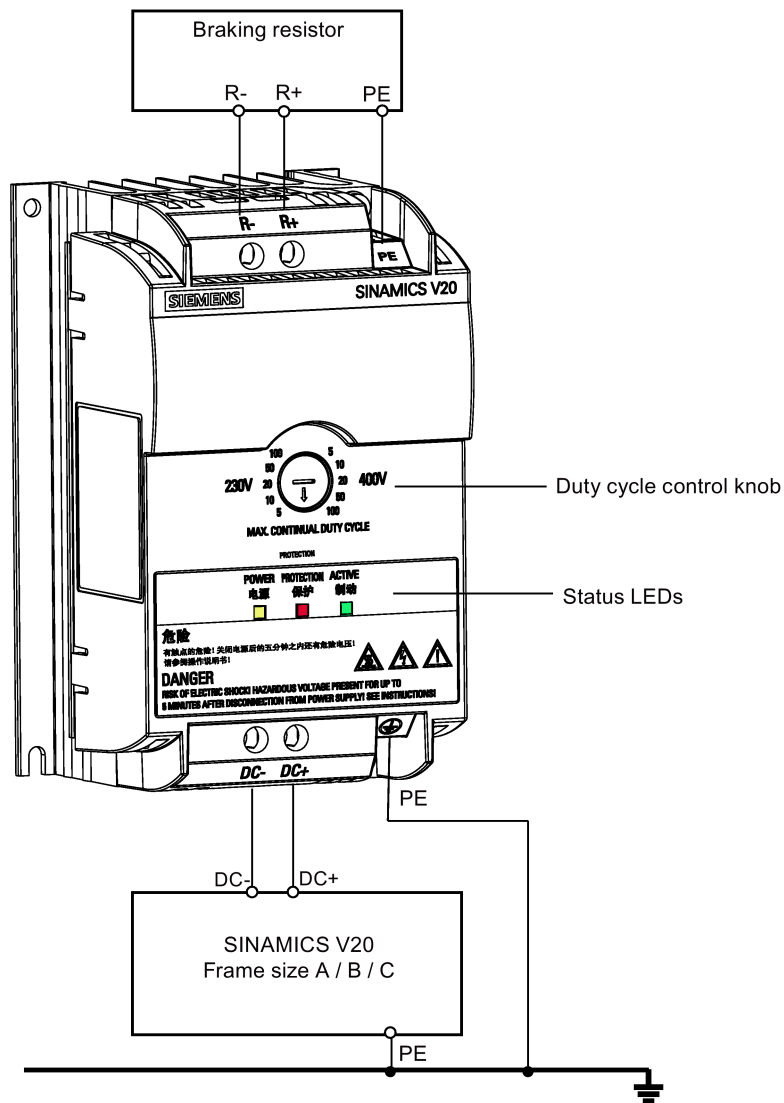

## Drill pattern (mm)

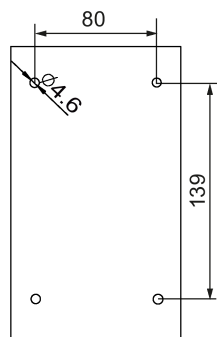

## Recommended cable cross-sections

Inverter frame size	Rated output power	Cable cross-sections for DC terminals (DC-, DC+)
230 V		
FSA	0.12 ... 0.75 kW	1.0 mm <sup>2</sup>
FSB	1.1 ... 1.5 kW	2.5 mm <sup>2</sup>
FSC	2.2 ... 3.0 kW	4.0 mm <sup>2</sup>
400 V		
FSA	0.37 ... 0.75 kW	1.0 mm <sup>2</sup>
	1.1 ... 2.2 kW	1.5 mm <sup>2</sup>
FSB	3.0 ... 4.0 kW	2.5 mm <sup>2</sup>
FSC	5.5 kW	4.0 mm <sup>2</sup>

Note: Do not use the cables with cross-sections less than 0.3 mm<sup>2</sup> (for inverter frame size A) / 0.5 mm<sup>2</sup> (for inverter frame sizes B and C). Use a screw tightening torque of 1.0 Nm (tolerance: ±10%).

 <b>WARNING</b>
<b>Destruction of device</b>
It is extremely important to ensure that the polarity of the DC link connections between the inverter and the dynamic braking module is correct. If the polarity of the DC terminals' connections is reversed, it could result in the destruction of the inverter and the module.

## Status LEDs

LED	Color	Description
POWER	Yellow	Module is powered up.
STATUS	Red	Module is in protection mode.
ACTIVE	Green	Module is releasing regenerative energy produced when the motor brakes into heat.

## Duty cycle selection

<b>NOTICE</b>
<b>Damage to the braking resistor</b>
Incorrect setting for the duty cycle / voltage could damage the attached braking resistor.

Use the control knob to select the rated duty cycle of the braking resistor.

Value labels on the module have the following meanings:

Label	Meaning
230 V	Duty cycle values labeled are for 230 V inverters
400 V	Duty cycle values labeled are for 400 V inverters
5	5% duty cycle
10	10% duty cycle
20	20% duty cycle
50	50% duty cycle
100	100% duty cycle

## Technical specifications

	One phase AC 230 V inverters	Three phase AC 400 V inverters
Peak power rating	3.0 kW	5.5 kW
RMS current at peak power	8.0 A	7.0 A
Maximum continuous power rating	3.0 kW	4.0 kW
Maximum continuous current rating	8.0 A	5.2 A
Maximum continuous power rating (side-by-side mounted)	1.5 kW	2.75 kW
Maximum continuous current rating (side-by-side mounted)	4.0 A	3.5 A
Surrounding air temperature	0 °C to 50 °C: without derating	0 °C to 40 °C: without derating 40 °C to 50 °C: with derating
Maximum continuous current rating at 50 °C surrounding air temperature	8.0 A	1.5 A
Outline dimensions (L x W x D)	150 x 90 x 88 (mm)	
Mounting	Cabinet panel mounting (4 x M4 screws)	
Maximum duty cycle	100%	
Protection functions	Short-circuit protection, over-temperature protection	
Maximum cable length	<ul style="list-style-type: none"> <li>Braking module to inverter: 1 m</li> <li>Braking module to braking resistor: 10 m</li> </ul>	

### B.1.5 Braking resistor

 <b>WARNING</b>
<b>Operation conditions</b> Make sure that the resistor to be fitted to the SINAMICS V20 is adequately rated to handle the required level of power dissipation. All applicable installation, usage and safety regulations regarding high voltage installations must be complied with. If the inverter is already in use, disconnect the prime power and wait at least five minutes for the capacitors to discharge before commencing installation. This equipment must be earthed.
<b>Extreme heat</b> Braking resistors get hot during operation. Do not touch the braking resistor during operation. Using an incorrect braking resistor can cause severe damage to the associated inverter and may result in fire. A thermal cut-out circuit (see diagram below) must be incorporated to protect the equipment from overheating.

<b>NOTICE</b>
<b>Minimum resistance values</b> A braking resistor with a resistance lower than the following minimum resistance values can damage the attached inverter or braking module: <ul style="list-style-type: none"><li>• 400 V inverter frame sizes A to C: 56 Ω</li><li>• 400 V inverter frame size D/E: 27 Ω</li><li>• 230 V inverter frame sizes A to C: 39 Ω</li></ul>

### Functionality

An external braking resistor can be used to "dump" the regenerative energy produced by the motor, thus giving greatly improved braking and deceleration capabilities.

A braking resistor which is required for dynamic braking can be used with all frame sizes of inverters. Frame size D is designed with an internal braking chopper, allowing you to connect the braking resistor directly to the inverter; however, for frame sizes A to C, an additional dynamic braking module is required for connecting the braking resistor to the inverter.



## Ordering data

Frame size	Inverter power rating	Resistor order number	Continuous power	Peak power (5% duty cycle)	Resistance $\pm$ 10%	DC voltage rating
<b>Three phase AC 400 V inverters</b>						
FSA	0.37 kW	6SL3201-0BE14-3AA0	75 W	1.5 kW	370 $\Omega$	840 V +10%
	0.55 kW					
	0.75 kW					
	1.1 kW					
	1.5 kW					
	2.2 kW	6SL3201-0BE21-0AA0	200 W	4.0 kW	140 $\Omega$	840 V +10%
FSB	3 kW	6SL3201-0BE21-8AA0	375 W	7.5 kW	75 $\Omega$	840 V +10%
	4 kW					
FSC	5.5 kW	6SL3201-0BE21-8AA0	375 W	7.5 kW	75 $\Omega$	840 V +10%
FSD	7.5 kW	6SL3201-0BE23-8AA0	925 W	18.5 kW	30 $\Omega$	840 V +10%
	11 kW					
	15 kW					
FSE	18.5 kW	6SE6400-4BD21-2DA0	1200 W	24 kW	27 $\Omega$	900 V
	22 kW					
<b>Single phase AC 230 V inverters</b>						
FSA	0.12 kW	6SE6400-4BC05-0AA0	50 W	1.0 kW	180 $\Omega$	450 V
	0.25 kW					
	0.37 kW					
	0.55 kW					
	0.75 kW					
FSB	1.1 kW	6SE6400-4BC11-2BA0	120 W	2.4 kW	68 $\Omega$	450 V
	1.5 kW					
FSC	2.2 kW	6SE6400-4BC12-5CA0	250 W	4.5 kW	39 $\Omega$	450 V
	3 kW					

\* All the above resistors are rated for a maximum duty cycle of 5%.

## Technical data

Surrounding operating temperature:	-10° C to +50° C
Storage/transport temperature:	-40° C to +70° C
Degree of protection:	IP20
Humidity:	0% to 95% (non-condensing)
cURus file number:	E221095 (Gino) E219022 (Block)

**Installation**

**For three phase AC 400 V inverters FSA to FSD**

The resistors can be installed in a vertical or horizontal position and secured to a heat resistant surface. The required minimum clearance distances are shown below:

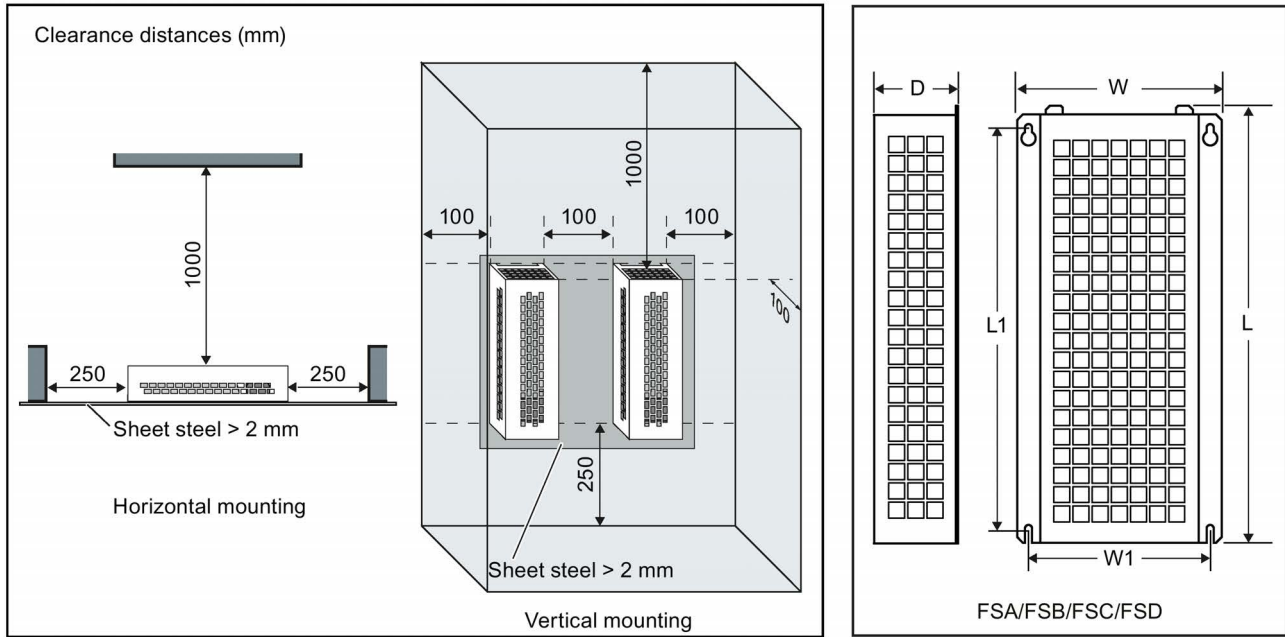

**For single phase AC 230 V inverters and three phase AC 400 V inverter FSE**

The resistors must be installed in a vertical position and secured to a heat resistant surface. At least 100 mm must be left above, below and to the side of the resistor to allow an unimpeded airflow.

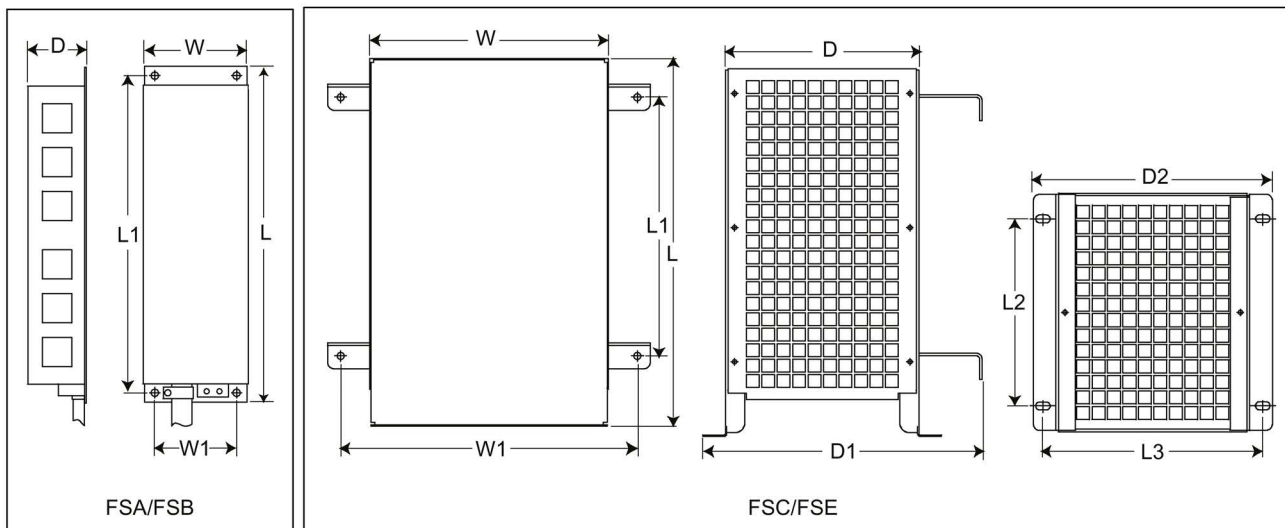

## Mounting dimensions

Resistor order number	Dimensions (mm)									Weight (kg)
	L	L1	L2	L3	D	D1	D2	W	W1	
<b>Three phase AC 400 V inverters</b>										
6SL3201-0BE14-3AA0	295	266	-	-	100	-	-	105	72	1.48
6SL3201-0BE21-0AA0	345	316	-	-	100	-	-	105	72	1.80
6SL3201-0BE21-8AA0	345	316	-	-	100	-	-	175	142	2.73
6SL3201-0BE23-8AA0	490	460	-	-	140	-	-	250	217	6.20
6SE6400-4BD21-2DA0	515	350	205	195	175	242	210	270	315	7.4
<b>Single phase AC 230 V inverters</b>										
<b>6SE6400-...</b>										
4BC05-0AA0	230	217	-	-	43.5	-	-	72	56	1.0
4BC11-2BA0	239	226	-	-	43.5	-	-	149	133	1.6
4BC12-5CA0	285	200	145	170	150	217	185	185	230	3.8

## Connection

The mains supply to the inverter can be provided through a contactor which disconnects the supply if the resistor overheats. Protection is provided by a thermal cut-out switch (supplied with each resistor). The cut-out switch can be wired in-series with the coil supply for the main contactor (see diagram below). The thermal switch contacts close again when the resistor temperature falls; after which the inverter starts automatically (P1210 = 1). A fault message is generated with this parameter setting.

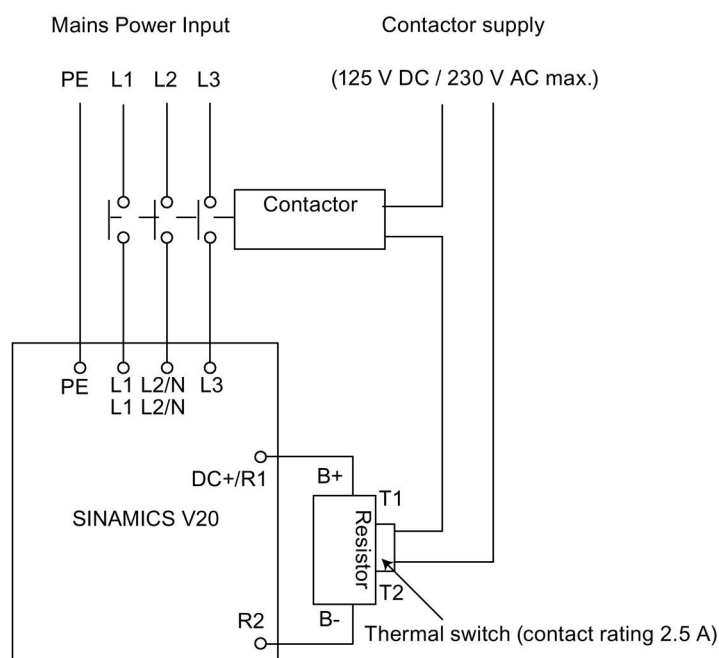

### Commissioning

The braking resistors are designed to operate on a 5% duty cycle. For inverter frame size D, set P1237 = 1 to enable the braking resistor function. For other frame sizes, use the dynamic braking module to select the 5% duty cycle.

---

**Note**

**Additional PE terminal**

Some resistors have an additional PE connection available on the resistor housing.

---

### B.1.6 Line reactor

 <b>WARNING</b>
<b>Heat during operation</b> The line reactors get hot during operation. Do not touch. Provide adequate clearance and ventilation. When operating the larger line reactors in an environment with a surrounding air temperature in excess of 40° C, the wiring of the terminal connections must be accomplished using 75° C copper wire only.

 <b>WARNING</b>
<b>Risk of equipment damage and electric shocks</b> Some of the line reactors in the table below have pin crimps for the connection to the inverter's mains terminals. Use of these pin crimps can cause damage to the equipment and even electric shocks. For safety reasons, replace the pin crimps using UL/cUL-certified fork crimps or stranded cables.

 <b>CAUTION</b>
<b>Protection rating</b> The line reactors have a protection rating of IP20 in accordance with EN 60529 and are designed to be mounted inside a cabinet.

### Functionality

The line reactors are used to smooth voltage peaks or to bridge commutating dips. They also can reduce the effects of harmonics on the inverter and the line supply.

The larger line reactors for the 230 V variants of inverters have side mounting brackets to allow side-by-side mounting (see diagram below).

## Ordering data

Frame size	Inverter power rating	Line reactor					
		Order number	Voltage	Current			
<b>Three phase AC 400 V inverters</b>							
FSA	0.37 kW	6SL3203-0CE13-2AA0	380 V to 480 V	4.0 A			
	0.55 kW						
	0.75 kW						
	1.1 kW						
	1.5 kW						
FSB	3 kW	6SL3203-0CE21-0AA0	380 V to 480 V	11.3 A			
	4 kW						
FSC	5.5 kW	6SL3203-0CE21-8AA0	380 V to 480 V	22.3 A			
FSD	7.5 kW	6SL3203-0CE23-8AA0	380 V to 480 V	47.0 A			
	11 kW						
	15 kW						
FSE	18.5 kW	6SE6400-3CC05-2DD0	200 V to 480 V	53.6 A			
	22 kW	6SE6400-3CC08-3ED0	380 V to 600 V	86.9 A			
<b>Single phase AC 230 V inverters</b>							
FSA	0.12 kW	6SE6400-3CC00-4AB3	200 V to 240 V	3.4 A			
	0.25 kW						
	0.37 kW				6SE6400-3CC01-0AB3	200 V to 240 V	8.1 A
	0.55 kW						
	0.75 kW						
FSB	1.1 kW	6SE6400-3CC02-6BB3	200 V to 240 V	22.8 A			
	1.5 kW						
FSC	2.2 kW	6SE6400-3CC03-5CB3	200 V to 240 V	29.5 A			
	3 kW						

### Connecting the line reactor to the inverter

The following illustration takes the line reactors for the 230 V variants of inverters as an example.

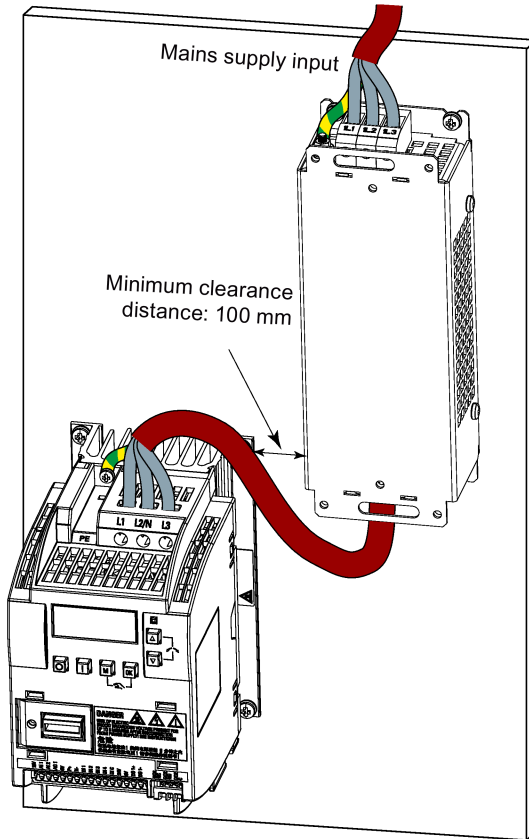

## Mounting dimensions

For three phase AC 400 V inverters FSA to FSD

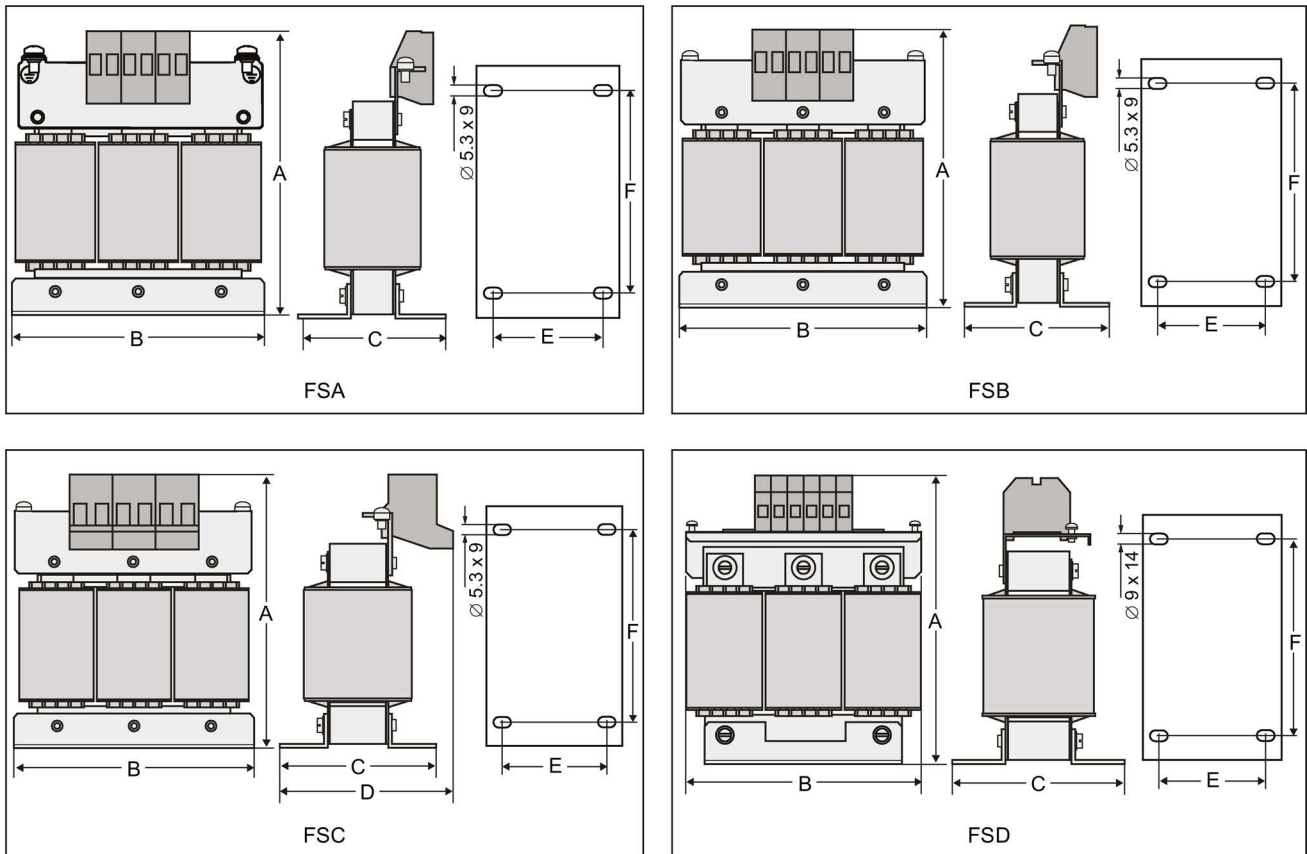

Order number 6SL3203-...	Dimensions (mm)						Weight (kg)	Fixing screw		Cable cross section (mm <sup>2</sup> )
	A	B	C	D	E	F		Size	Tightening torque (Nm)	
0CE13-2AA0	120	125	71	-	55	100	1.10	M4 (4)	3.0	2.5
0CE21-0AA0	140	125	71	-	55	100	2.10	M4 (4)	3.0	2.5
0CE21-8AA0	145	125	81	91	65	100	2.95	M5 (4)	5.0	6.0
0CE23-8AA0	220	190	91	-	68	170	7.80	M5 (4)	5.0	16.0

For three phase AC 400 V inverter FSE

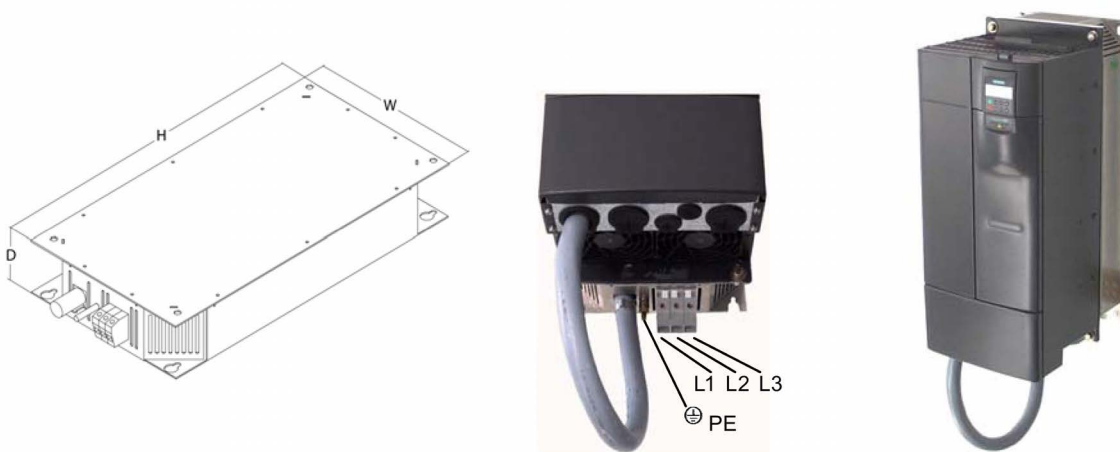

Order number 6SL6400- ...	Electrical characteristics			Overall dimensions (mm)						Fixing dimensions (mm)		Fixing screw	Weight (kg)
				Line reactor			Drive envelope						
	Voltage (V)	Current (A)	Torque (Nm)	H	W	D	H	W	D	H	W		
3CC05-2DD0	200 to 480	53.6	2.0 to 2.3	520	275	85	520	275	330	486	235	M8 (13 Nm+13 %)	9.5
3CC08-3ED0	380 to 600	86.9	6.0 to 8.0	650	275	95	650	275	340	616.4	235	M8 (13 Nm+13 %)	17.0

For single phase AC 230 V inverters

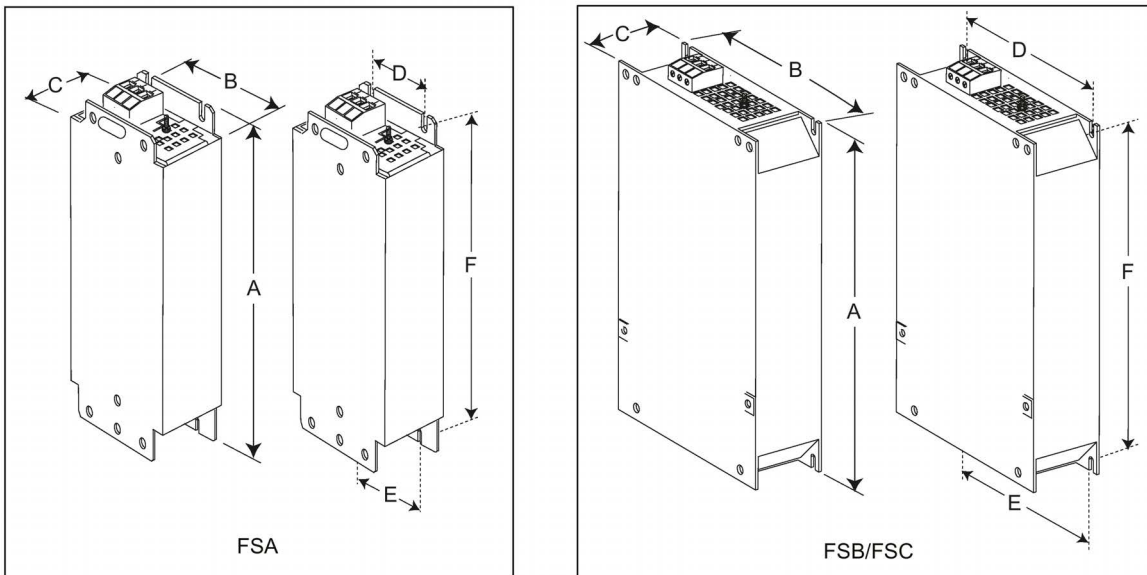



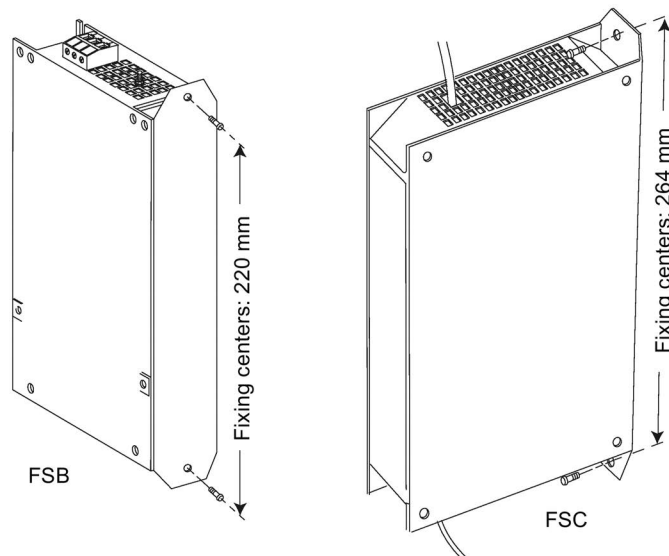

Order number 6SE6400-...	Dimensions (mm)						Weight (kg)	Fixing screw		Cable cross section (mm <sup>2</sup> )	
	A	B	C	D	E	F		Size	Tightening torque (Nm)	Min.	Max.
3CC00-4AB3	200	75.5	50	56	56	187	0.5	M4 (2)	1.1	1.0	2.5
3CC01-0AB3	200	75.5	50	56	56	187	0.5	M4 (2)			
3CC02-6BB3	213 (233*)	150	50	138	120	200	1.2	M4 (4)	1.5	1.5	6.0
3CC03-5CB3	245 (280*)	185	50 (50/80*)	174	156	230	1.0	M5 (4)	2.25	2.5	10

\* Height with side-mounting bracket

### B.1.7 Output reactor

**⚠ CAUTION**

**Pulse frequency restriction**

The output reactor works only at 4kHz switching frequency. Before the output reactor is used, parameters P1800 and P0290 must be modified as follows: P1800 = 4 and P0290 = 0 or 1.

#### Functionality

The output reactors reduce the voltage stress on the motor windings. At the same time, the capacitive charging / discharging currents, which place an additional load on the inverter output when long motor cables are used, are reduced.

Make sure you use a shielded cable (maximum length: 100 m) to connect the output reactor.

#### Ordering data

Frame size	Inverter power rating	Output reactor		
		Order number	Voltage	Current
<b>Three phase AC 400 V inverters</b>				
FSA	0.37 kW	6SL3202-0AE16-1CA0	380 V to 480 V	6.1 A
	0.55 kW			
	0.75 kW			
	1.1 kW			
	1.5 kW			
	2.2 kW	6SL3202-0AE18-8CA0	380 V to 480 V	9.0 A
FSB	3 kW	6SL3202-0AE21-8CA0	380 V to 480 V	18.5 A
	4 kW			
FSC	5.5 kW	6SL3202-0AE23-8CA0	380 V to 480 V	39.0 A
FSD	7.5 kW			
	11 kW			
FSE	15 kW	6SE6400-3TC05-4DD0	200 V to 480 V	54.0 A
	18.5 kW			
	22 kW			
<b>Single phase AC 230 V inverters</b>				
FSA	0.12 kW	6SE6400-3TC00-4AD3	200 V to 240 V	4.0 A
	0.25 kW			
	0.37 kW			
	0.55 kW			
	0.75 kW			
	1.1 kW	6SE6400-3TC01-0BD3	200 V to 480 V	10.4 A
FSB	1.5 kW	6SE6400-3TC03-2CD3	200 V to 480 V	26.0 A
FSC	2.2 kW			
	3 kW			

## Connecting the output reactor to the inverter

The following illustration takes the output reactors for the 230 V variants of inverters as an example.

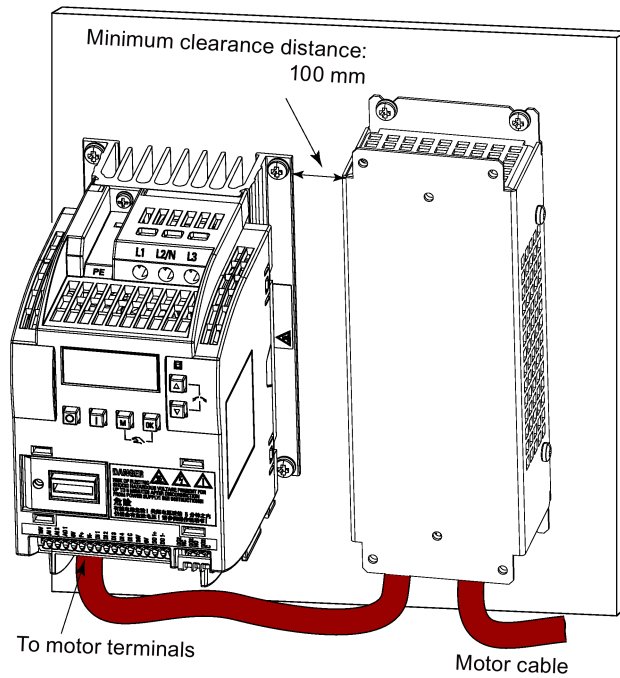

Mounting dimensions

For three phase AC 400 V inverters FSA to FSD

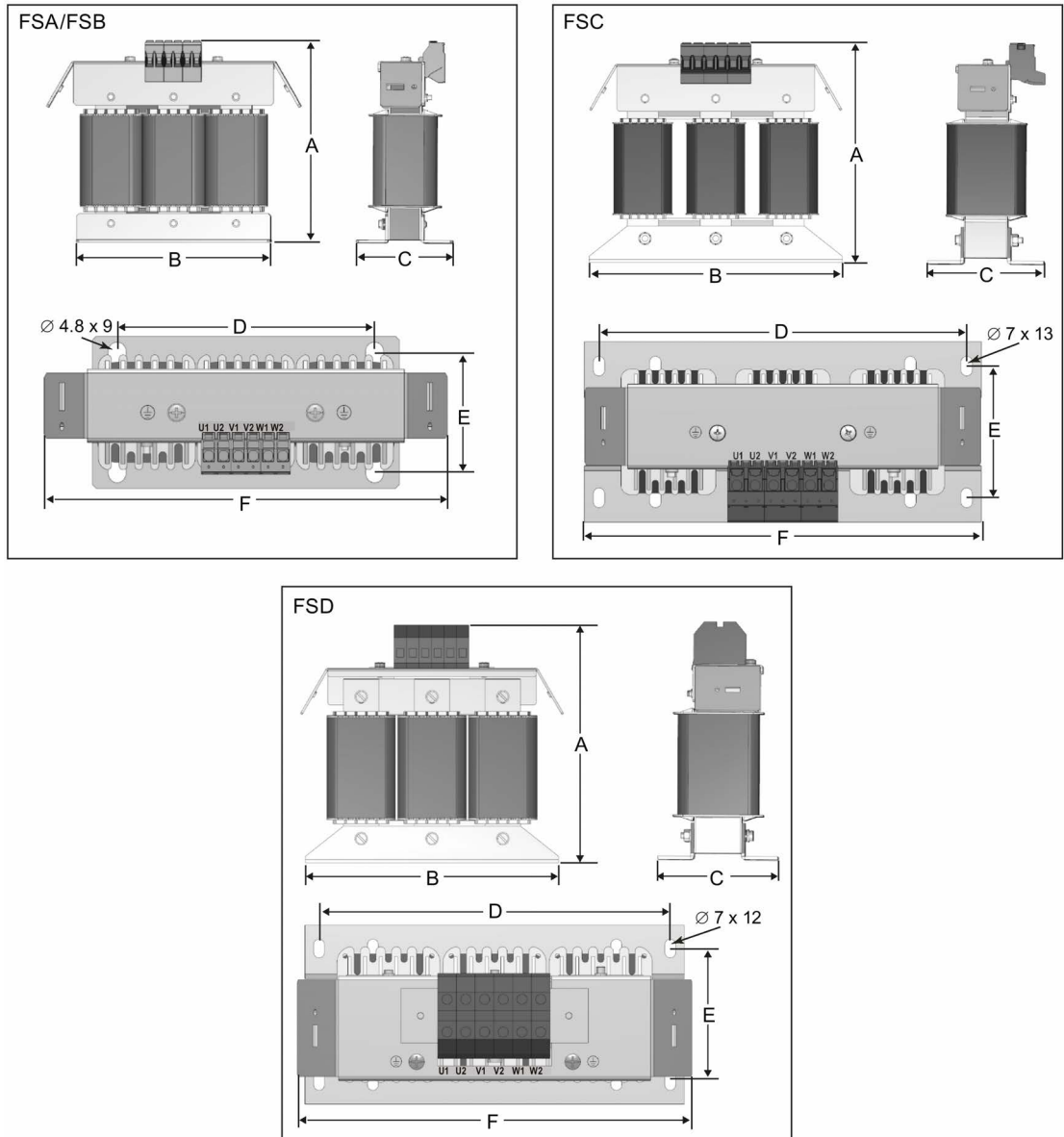

Order number 6SL3202-...	Dimensions (mm)						Weight (kg)	Fixing screw		Cable cross section (mm <sup>2</sup> )
	A	B	C	D	E	F		Size	Tightening torque (Nm)	
0AE16-1CA0	175	178	72.5	166	56.5	207	3.4	M4 (4)	3.0	4.0
0AE18-8CA0	180	178	72.5	166	56.5	207	3.9	M4 (4)	3.0	4.0
0AE21-8CA0	215	243	100	225	80.5	247	10.1	M5 (4)	5.0	10.0
0AE23-8CA0	235	243	114.7	225	84.7	257	11.2	M5 (4)	5.0	16.0

## For three phase AC 400 V inverter FSE

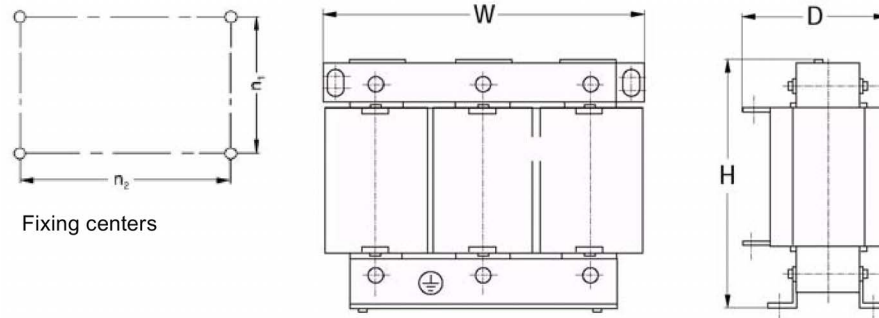

Order number	Electrical characteristics			Connecting bolt	Overall dimensions (mm)			Fixing dimensions (mm)		Fixing screw	Weight (kg)
	Voltage (V)	Current (A)	Torque (Nm)		H	W	D	n1	n2		
6SE6400-											
3TC05-4DD0	200 to 480	54	3.5 to 4.0	M5	210	225	150	70	176	M6	10.7

## For single phase AC 230 V inverters

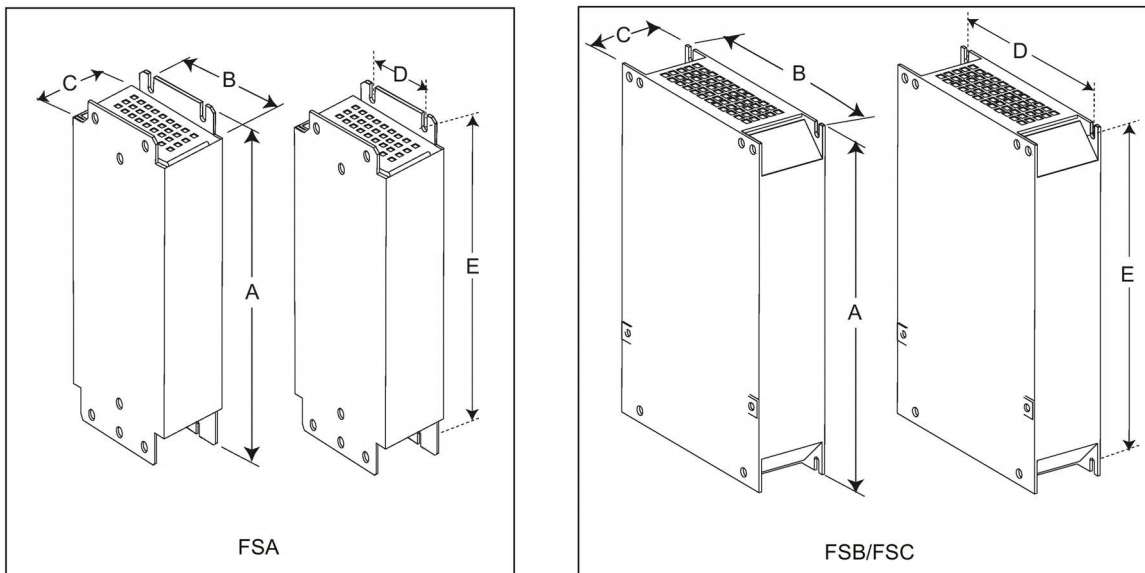

Order number	Dimensions (mm)					Weight (kg)	Fixing screw		Cable cross section (mm <sup>2</sup> )	
	A	B	C	D	E		Size	Tightening torque (Nm)	Min.	Max.
6SE6400-...										
3TC00-4AD3	200	75.5	50	56	187	1.3	M4 (4)	1.1	1.0	2.5
3TC01-0BD3	213	150	80	120	200	4.1	M4 (4)	1.5	1.5	6.0
3TC03-2CD3	245	185	80	156	232	6.6	M4 (4)	2.25	2.5	10

### B.1.8 External EMC filter class B

**⚠ WARNING**

**Risk of equipment damage and electric shocks**

Some of the EMC filters in the table below have pin crimps for the connection to the inverter's PE and mains terminals.

Use of these pin crimps can cause damage to the equipment and even electric shocks.

For safety reasons, replace the pin crimps using appropriately sized UL/cUL-certified fork or ring crimps for PE terminal connection, and using UL/cUL-certified fork crimps or stranded cables for mains terminal connection.

**Note**

The EMC filter with an order number of 6SE6400-2FL02-6BB0 in the following table has two DC terminals (DC+, DC-) that are not used and should not be connected. The cables of these terminals need to be cut back and suitably insulated (for example, with heat shrink shroud).

#### Functionality

In order to achieve EN61800-3 Category C2 Radiated and Conducted Emission, the external EMC filters shown below are required for the SINAMICS V20 inverters (400 V filtered and unfiltered variants, as well as 230 V unfiltered variants). In this case, only a screened output cable can be used, and the maximum cable length is 25 m for the 400 V variants or 5 m for the 230 V variants.

#### Ordering data

Frame size	Inverter power rating	EMC filter class B		
		Order number	Voltage	Current
<b>Three phase AC 400 V inverters</b>				
FSA	0.37 kW	6SL3203-0BE17-7BA0	380 V to 480 V	11.4 A
	0.55 kW			
	0.75 kW			
	1.1 kW			
	1.5 kW			
	2.2 kW			
FSB	3 kW	6SL3203-0BE21-8BA0	380 V to 480 V	23.5 A
	4 kW			
FSC	5.5 kW	6SL3203-0BE23-8BA0	380 V to 480 V	49.4 A
FSD	7.5 kW			
	11 kW			
FSE	15 kW	6SL3203-0BE27-5BA0	380 V to 480 V	72 A
	18.5 kW			
	22 kW			

Frame size	Inverter power rating	EMC filter class B		
		Order number	Voltage	Current
<b>Single phase AC 230 V inverters</b>				
FSA	0.12 kW	6SE6400-2FL01-0AB0	200 V to 240 V	10 A
	0.25 kW			
	0.37 kW			
	0.55 kW			
	0.75 kW			
FSB	1.1 kW	6SE6400-2FL02-6BB0	200 V to 240 V	26 A
	1.5 kW			
FSC	2.2 kW	Siemens recommends you to use the EMC filter of Type "EPCOS B84113H000 G136" or equivalent.		
	3 kW			

## Installation

For the EMC-compliant installation of the external EMC filters, refer to Section "EMC-compliant installation (Page 45)".

### Connecting the EMC filter to the inverter

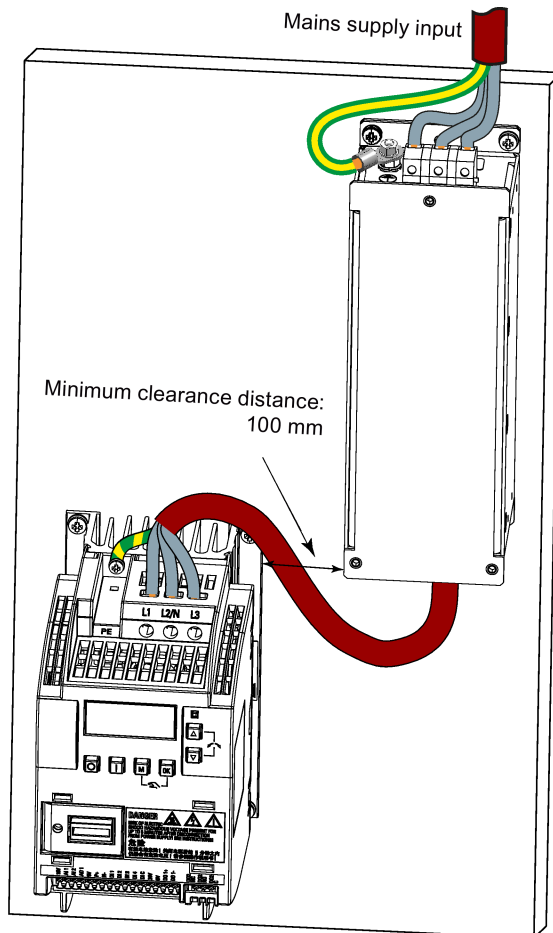

Mounting dimensions

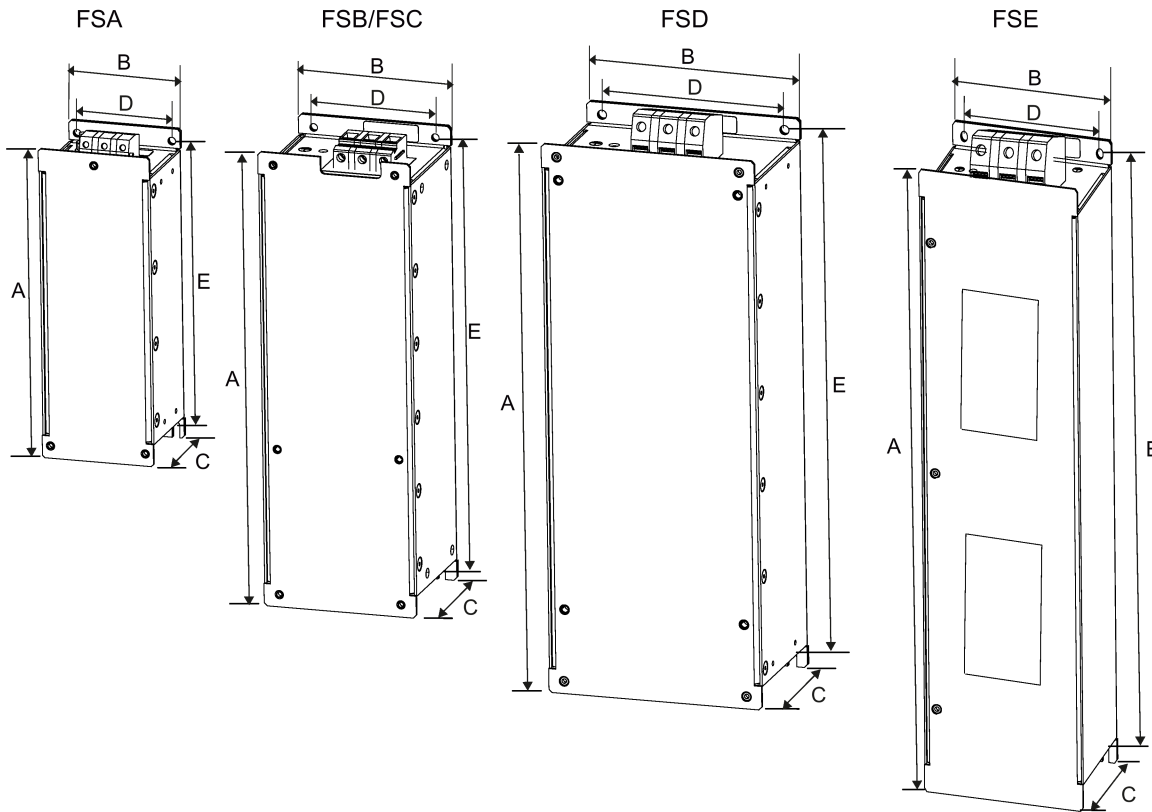

Order number	Dimensions (mm)					Weight (kg)	Fixing screw		Cable cross section (mm <sup>2</sup> )	
	A	B	C	D	E		Size	Tightening torque (Nm)	Min.	Max.
<b>Three phase AC 400 V inverters</b>										
6SL3203-0BE17-7BA0	202	73	65	36.5	186	1.75	M4 (4)	0.6 to 0.8	1.0	2.5
6SL3203-0BE21-8BA0	297	100	85	80	281	4.0	M4 (4)	1.5 to 1.8	1.5	6.0
6SL3203-0BE23-8BA0	359	140	95	120	343	7.3	M4 (4)	2.0 to 2.3	6.0	16.0
6SL3203-0BE27-5BA0	400	100	140	75	385	7.6	M6 (4)	3.0	16.0	50.0
<b>Single phase AC 230 V inverters</b>										
6SE6400-2FL01-0AB0	200	73	43.5	56	187	0.5	M5 (4)	1.1	1.0	2.5
6SE6400-2FL02-6BB0	213	149	50.5	120	200	1.0	M5 (4)	1.5	1.5	6.0
6SE6400-2FS03-5CB0	245	185	55	156	232	1.5	M5 (4)	2.25	2.5	10



## B.1.9 Shield connection kits

### Functionality

The shield connection kit is supplied as an option for each frame size. It allows easy and efficient connection of the necessary shield to achieve EMC-compliant installation of the inverter (see Section "EMC-compliant installation (Page 45)" for details).

### Components

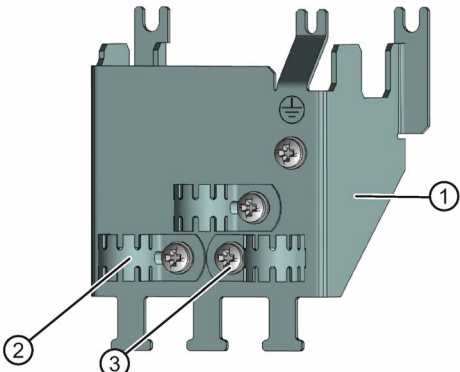
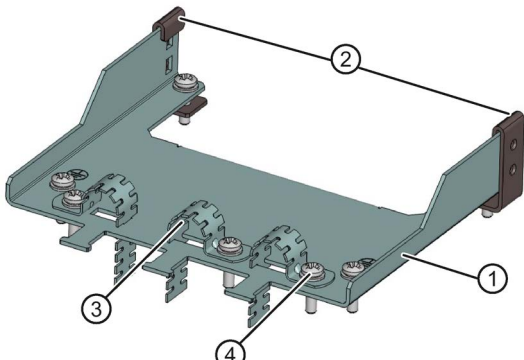
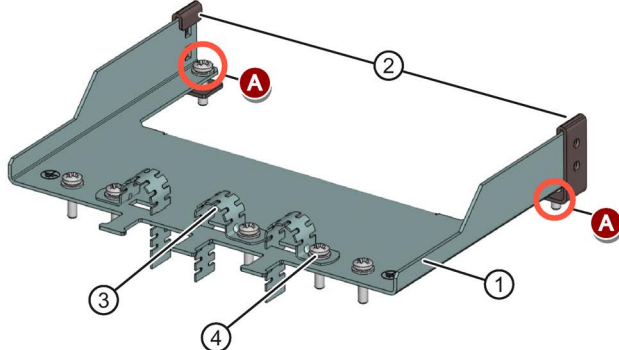
Inverter variant	Shield connection kit	
	Illustration	Components
FSA	Order number: 6SL3266-1AA00-0VA0 	① Shielding plate ② 3 × cable shield clamps ③ 4 × M4 screws (tightening torque: 1.8 Nm ± 10%)
FSB	Order number: 6SL3266-1AB00-0VA0 	① Shielding plate ② 2 × clips <sup>1)</sup> ③ 3 × cable shield clamps ④ 7 × M4 screws (tightening torque: 1.8 Nm ± 10%)
FSC	Order number: 6SL3266-1AC00-0VA0 	① Shielding plate ② 2 × clips <sup>1)</sup> ③ 3 × cable shield clamps ④ 7 × M4 screws (tightening torque: 1.8 Nm ± 10%) <sup>2)</sup>

Inverter variant	Shield connection kit	
	Illustration	Components
FSD/FSE	Order number: 6SL3266-1AD00-0VA0 (FSD) Order number: 6SL3266-1AE00-0VA0 (FSE)	① Shielding plate ② 2 × clips <sup>1)</sup> ③ 4 × cable shield clamps ④ 8 × M4 screws (tightening torque: 1.8 Nm ± 10%) <sup>2)</sup>

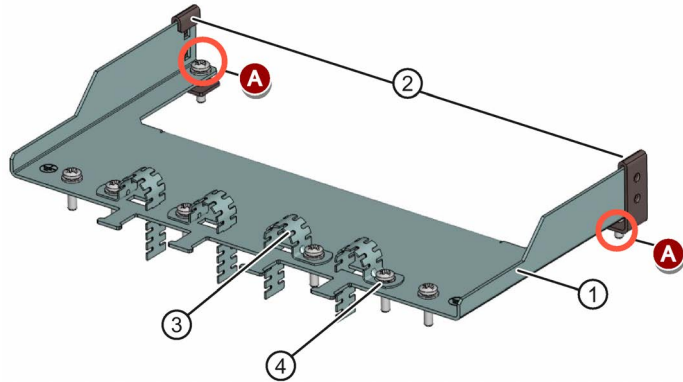

- 1) The clips are required only when fixing the shielding plate to the cabinet panel-mounted inverter.
- 2) For "push-through" applications, you must use two M5 screws and nuts (tightening torque: 2.5 Nm ± 10%) rather than two M4 screws ("A" in the illustration) to fix the shielding plate to the inverter.

Outline dimensions (mm)

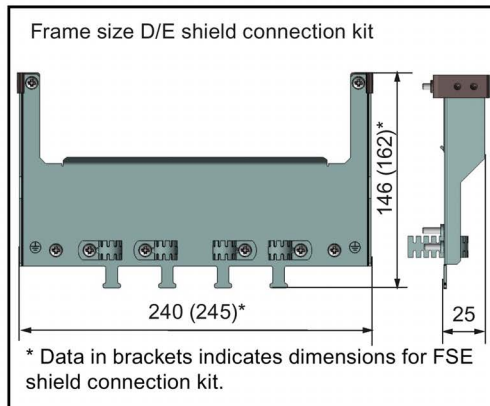
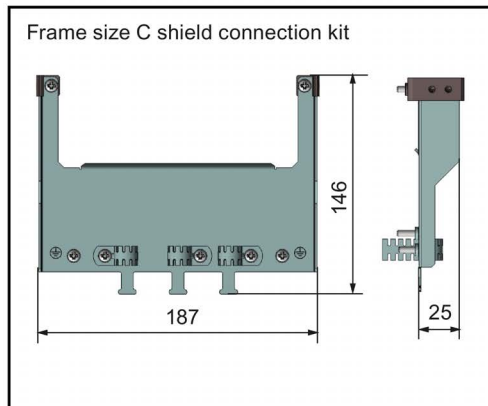
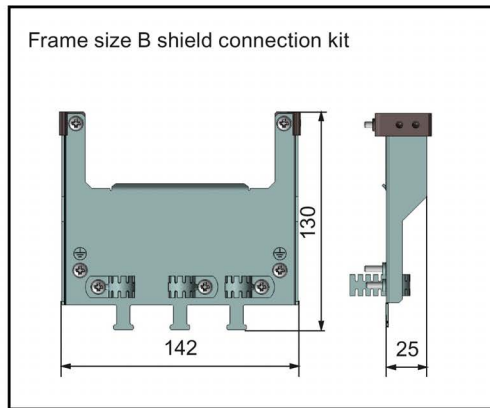
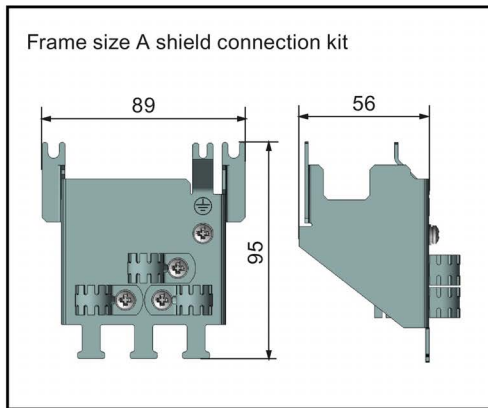

\* Data in brackets indicates dimensions for FSE shield connection kit.

## Fixing the shield connection kit to the inverter

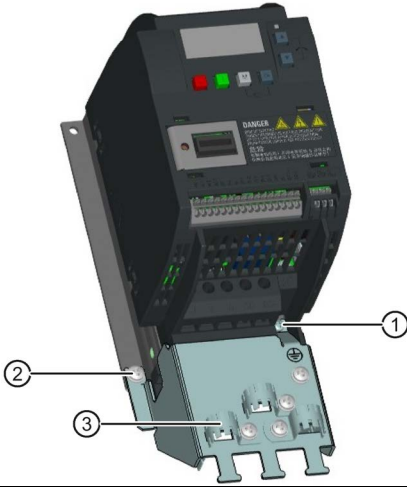
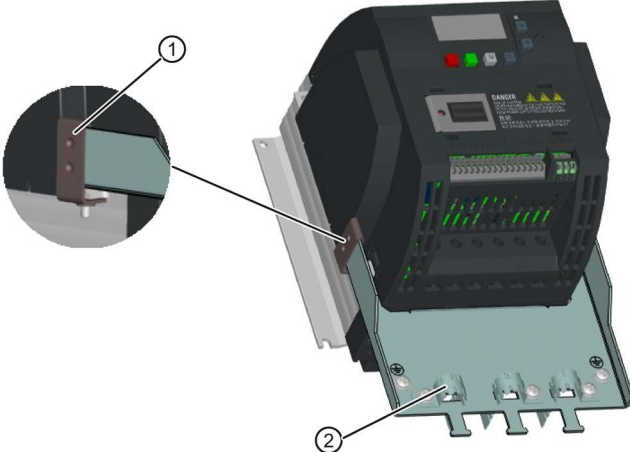
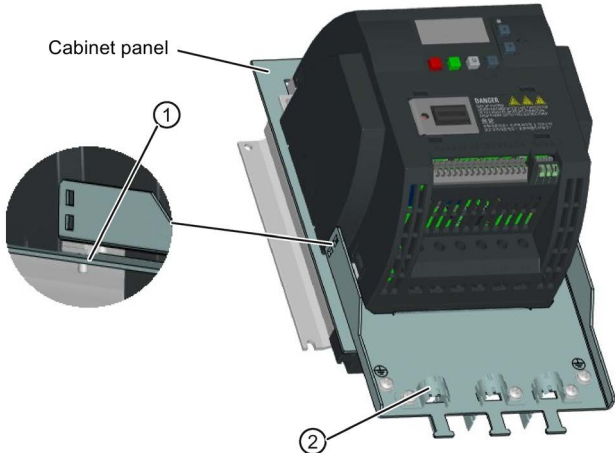
<p><b>If the inverter applies cabinet-panel mounting mode:</b></p>	
<p>Fixing to FSA</p> 	<ol style="list-style-type: none"> <li>① Loosen the PE screw and slide the shielding plate from below, then retighten the screw to 1.8 Nm (tolerance: <math>\pm 10\%</math>).</li> <li>② Clamp the heatsink between the shielding plate and the cabinet panel and tighten the screws and nuts to 1.8 Nm (tolerance: <math>\pm 10\%</math>).</li> <li>③ Fold the cable shield clamp to suit the cable diameter during inverter installation.</li> </ol>
<p>Fixing to FSB/FSC/FSD/FSE</p> 	<ol style="list-style-type: none"> <li>① Clamp the heatsink between the clip and the shielding plate and tighten the screw to 1.8 Nm (tolerance: <math>\pm 10\%</math>).</li> <li>② Fold the cable shield clamp to suit the cable diameter during inverter installation.</li> </ol>
<p><b>If the inverter applies push-through mounting mode:</b></p>	
<p>Fixing to FSB/FSC/FSD/FSE</p> <p>Cabinet panel</p> 	<p>Note that the clips are not required in this case.</p> <ol style="list-style-type: none"> <li>① Clamp the heatsink between the shielding plate and the cabinet panel, and use two mating nuts instead of the clips to tighten the screws (M4 screws if frame size B or M5 screws if frame size C or D) from the back of the cabinet panel. Screw tightening torque: M4 = 1.8 Nm <math>\pm 10\%</math>; M5 = 2.5 Nm <math>\pm 10\%</math></li> <li>② Fold the cable shield clamp to suit the cable diameter during inverter installation.</li> </ol>

### B.1.10 Memory card

#### Functionality

A memory card can be used on the Parameter Loader and allows you to upload / download parameter sets to / from the inverter. For detailed use of the memory card, refer to Appendix "Parameter Loader (Page 301)".

#### Order number

The MMC / SD cards with the following order numbers are recommended.

- MMC card: 6SL3254-0AM00-0AA0
- SD card: 6SL3054-4AG00-2AA0

### B.1.11 RS485 termination resistor

An RS485 termination resistor is used to terminate the bus for the RS485 communication between the SINAMICS V20 and SIEMENS PLCs. For detailed use of the termination resistor, refer to Section "Communicating with the PLC (Page 133)".

Order number: 6SL3255-0VC00-0HA0

### B.1.12 DIN rail mounting kits

#### DIN rail mounting kits (for frame sizes A and B only)

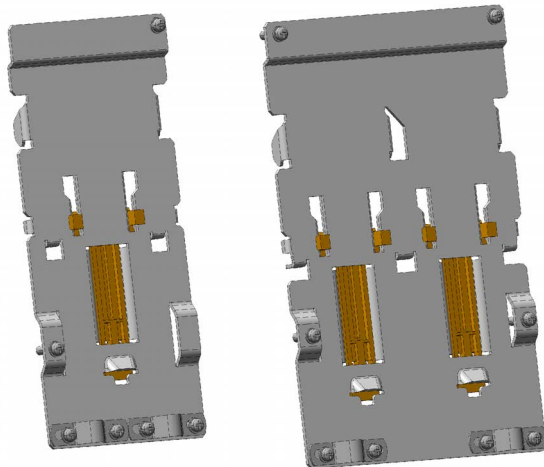

DIN rail kit for frame size A

Din rail kit for frame size B

Order numbers:

- 6SL3261-1BA00-0AA0 (for frame size A)
- 6SL3261-1BB00-0AA0 (for frame size B)

## **B.1.13 User documentation**

### **Operating Instructions (Chinese version)**

Order number: 6SL3298-0AV02-0FP0

## **B.2 Spare parts - replacement fans**

### **Order numbers**

Replacement fan for frame size A: 6SL3200-0UF01-0AA0

Replacement fan for frame size B: 6SL3200-0UF02-0AA0

Replacement fan for frame size C: 6SL3200-0UF03-0AA0

Replacement fan for frame size D: 6SL3200-0UF04-0AA0

Replacement fan for frame size E: 6SL3200-0UF05-0AA0

### **Replacing fans**

Proceed through the steps as illustrated below to remove the fan from the inverter. To re-assemble the fan, proceed in reverse order. When re-assembling the fan, make sure that the arrow symbol ("A" in the illustration) on the fan points to the inverter rather than the fan housing, the position for the fan cable exit point ("B") as well as the mounting orientation and position of the cable connector ("C") are sufficient for connecting the fan cable to the inverter.

### Replacing the fan from FSA

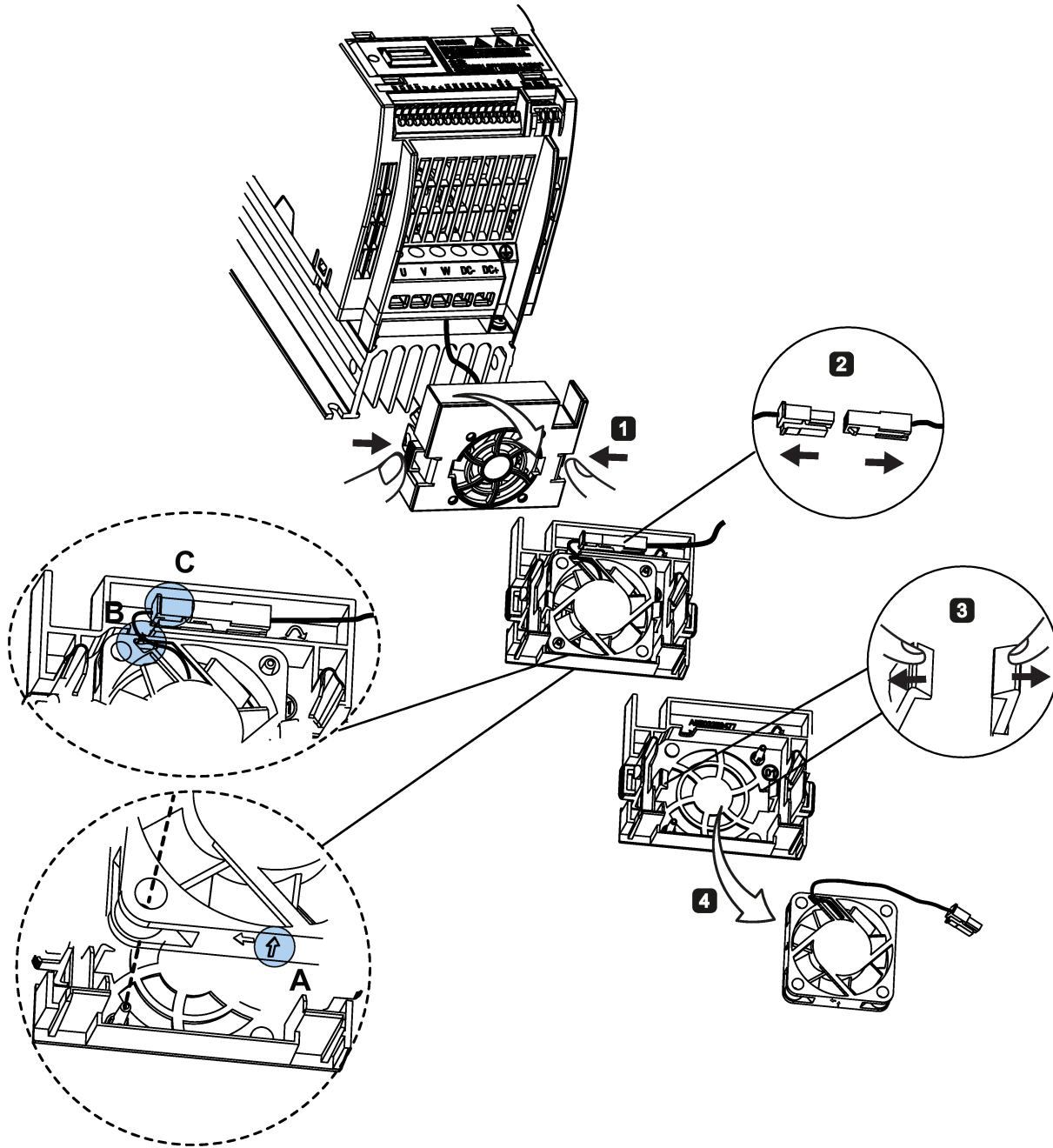

Replacing the fan(s) from FSB, FSC or FSD

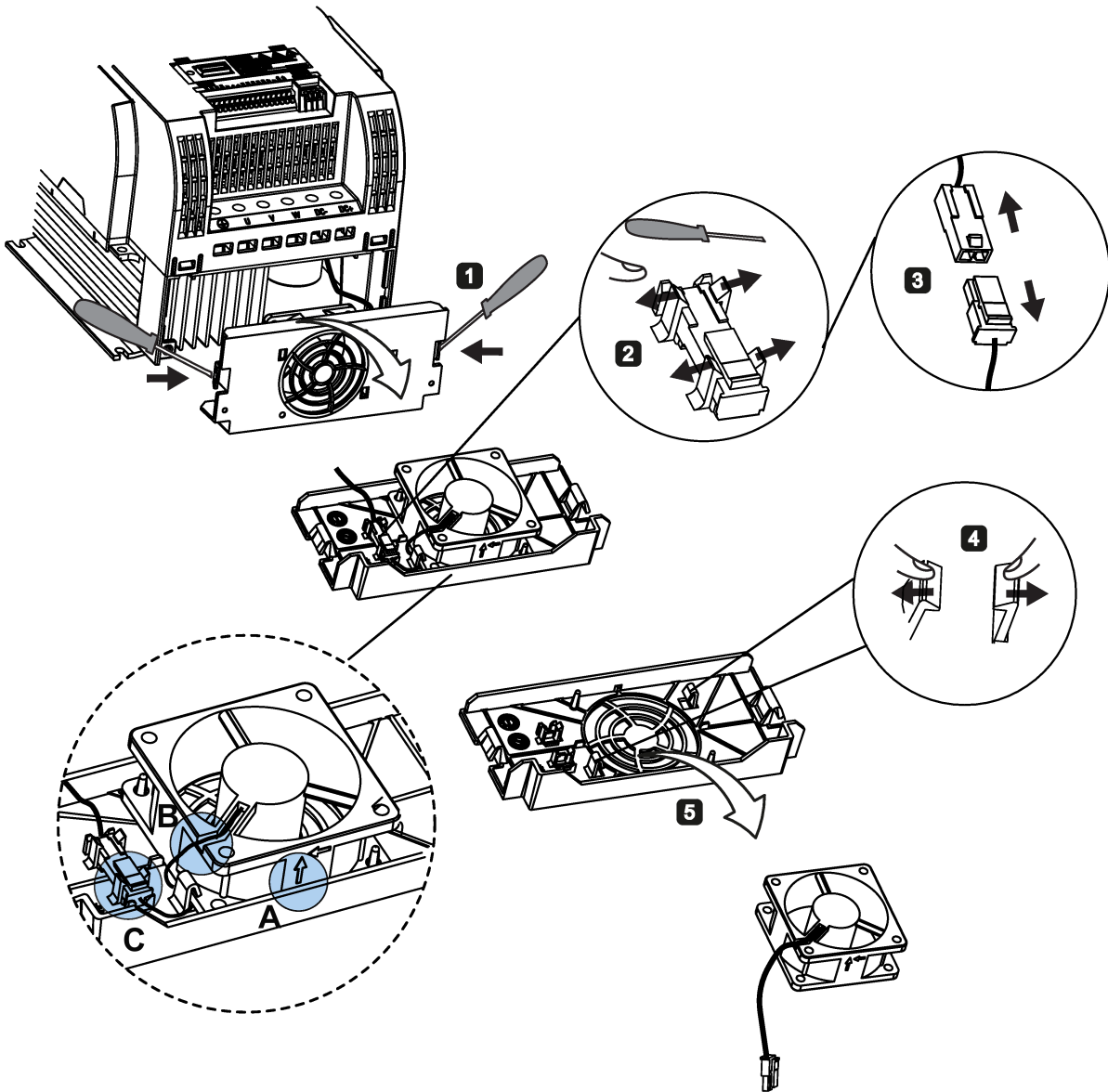

Replacing the fans from FSE

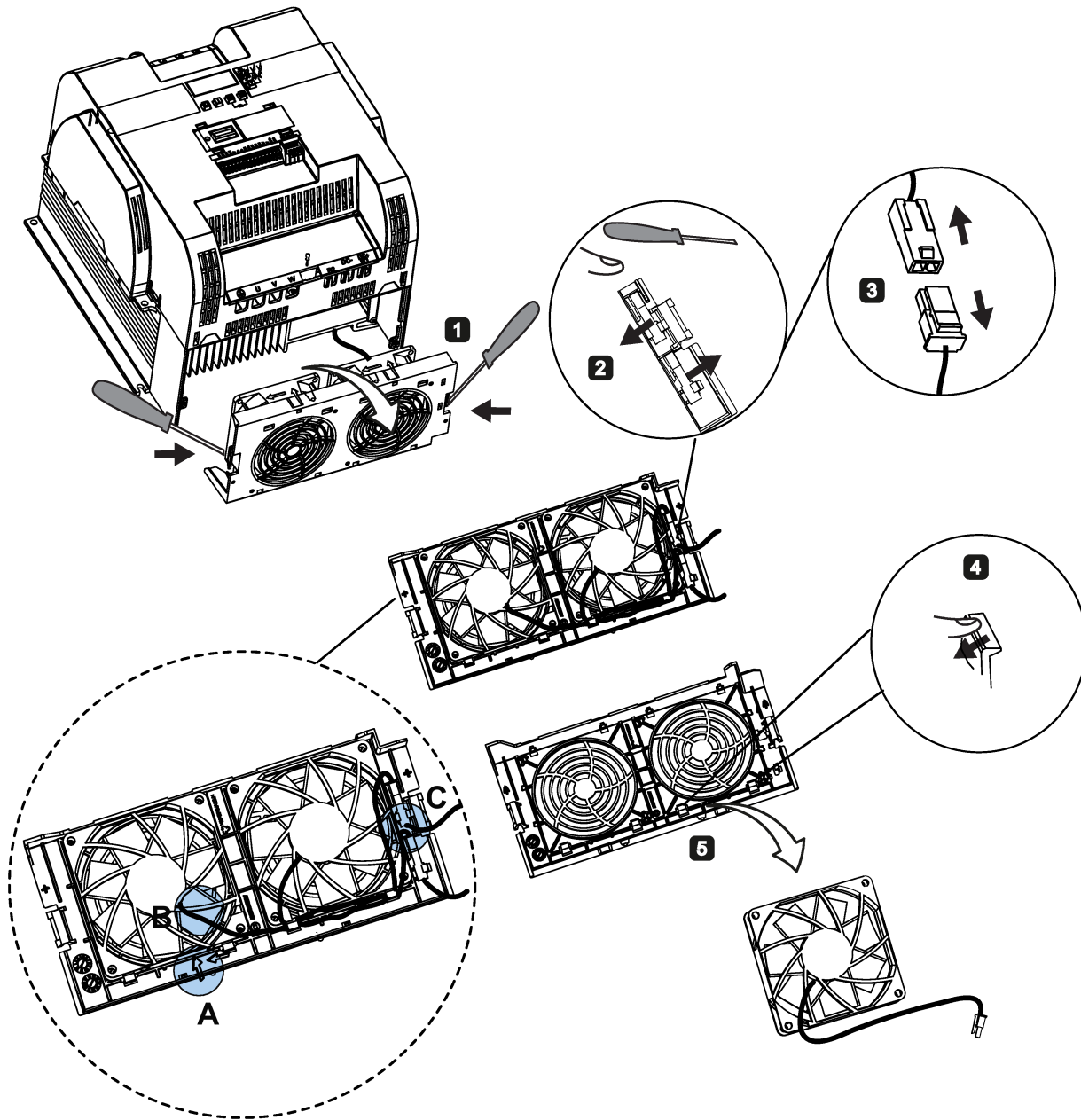



# Index

## A

### Advanced functions

- Automatic restart, 117
- Blockage clearing, 111
- Cavitation protection, 125
- Condensation protection, 119
- Dual ramp function, 127
- Economy mode, 113
- Flying start, 116
- Free functions blocks (FFBs), 115
- Frost protection, 118
- Hammer start, 109
- High/low overload (HO/LO) mode, 131
- Motor staging, 122
- Sleep mode, 120
- Super torque, 107
- UL508C-compliant motor overheat protection, 114
- User default parameter set, 126
- Wobble function, 121

### Alarm code list, 289

## B

### Basic functions

- Boost functions, 87
- Braking functions, 91
- I<sub>max</sub> controller, 102
- JOG function, 86
- Load torque monitoring, 105
- OFF functions, 83
- PID controller, 89
- Ramp time, 100
- V<sub>dc</sub> controller, 104

### BI

- P0731[0...2], 182
- P0732[0...2], 182
- P0806, 187
- P0810, 187
- P0811, 188
- P0820, 188
- P0821, 188
- P0840[0...2], 188
- P0842[0...2], 188
- P0843[0...2], 189
- P0844[0...2], 189

- P0845[0...2], 189
- P0848[0...2], 189
- P0849[0...2], 189
- P0852[0...2], 189
- P0881[0...2], 190
- P0882[0...2], 190
- P0883[0...2], 190
- P1020[0...2], 199
- P1021[0...2], 199
- P1022[0...2], 199
- P1023[0...2], 200
- P1035[0...2], 200
- P1036[0...2], 200
- P1041[0...2], 201
- P1043[0...2], 201
- P1055[0...2], 202
- P1056[0...2], 202
- P1074[0...2], 203
- P1110[0...2], 205
- P1113[0...2], 205
- P1124[0...2], 206
- P1140[0...2], 207
- P1141[0...2], 207
- P1142[0...2], 207
- P1175[0...2], 208
- P1218[0...2], 211
- P1230[0...2], 212
- P2103[0...2], 237
- P2104[0...2], 237
- P2106[0...2], 237
- P2200[0...2], 243
- P2220[0...2], 245
- P2221[0...2], 245
- P2222[0...2], 245
- P2223[0...2], 245
- P2235[0...2], 246
- P2236[0...2], 246
- P2241[0...2], 247
- P2243[0...2], 247
- P2810[0...1], 259
- P2812[0...1], 260
- P2814[0...1], 260
- P2816[0...1], 260
- P2818[0...1], 261

P2820[0...1], 261  
 P2822[0...1], 261  
 P2824[0...1], 261  
 P2826[0...1], 261  
 P2828, 262  
 P2830, 262  
 P2832, 262  
 P2834[0...3], 262  
 P2837[0...3], 263  
 P2840[0...1], 264  
 P2843[0...1], 264  
 P2846[0...1], 264  
 P2849, 265  
 P2854, 266  
 P2859, 267  
 P2864, 267  
 P2940, 270  
 P3351[0...2], 274  
 P3852[0...2], 277

BO

r0807.0, 187  
 r1025.0, 200  
 r2036.0...15, 236  
 r2037.0...15, 236  
 r2225.0, 246  
 r2811.0, 260  
 r2813.0, 260  
 r2815.0, 260  
 r2817.0, 260  
 r2819.0, 261  
 r2821.0, 261  
 r2823.0, 261  
 r2825.0, 261  
 r2827.0, 262  
 r2829.0, 262  
 r2831.0, 262  
 r2833.0, 262  
 r2835.0, 263  
 r2836.0, 263  
 r2838.0, 263  
 r2839.0, 263  
 r2841.0, 264  
 r2842.0, 264  
 r2844.0, 264  
 r2845.0, 264  
 r2847.0, 264  
 r2848.0, 264  
 r2852.0, 266  
 r2853.0, 266  
 r2857.0, 266  
 r2858.0, 266  
 r2862.0, 267

r2863.0, 267  
 r2867.0, 267  
 r2868.0, 267  
 r2886.0, 270  
 r2888.0, 270

Built-in BOP

button functions, 50  
 operating modes Hand/Jog/Auto, 50  
 screen displays, 56  
 status icons, 51  
 status LEDs, 58

C

CDS

P0700[0...2], 176  
 P0701[0...2], 177  
 P0702[0...2], 177  
 P0703[0...2], 177  
 P0704[0...2], 178  
 P0712[0...2], 178  
 P0713[0...2], 178  
 P0719[0...2], 178  
 P0727[0...2], 179  
 P0731[0...2], 182  
 P0732[0...2], 182  
 P0840[0...2], 188  
 P0842[0...2], 188  
 P0843[0...2], 189  
 P0844[0...2], 189  
 P0845[0...2], 189  
 P0848[0...2], 189  
 P0849[0...2], 189  
 P0852[0...2], 189  
 P0881[0...2], 190  
 P0882[0...2], 190  
 P0883[0...2], 190  
 P0886[0...2], 190  
 P1000[0...2], 196  
 P1020[0...2], 199  
 P1021[0...2], 199  
 P1022[0...2], 199  
 P1023[0...2], 200  
 P1035[0...2], 200  
 P1036[0...2], 200  
 P1041[0...2], 201  
 P1042[0...2], 201  
 P1043[0...2], 201  
 P1044[0...2], 201  
 P1055[0...2], 202  
 P1056[0...2], 202  
 P1070[0...2], 203

- P1071[0...2], 203  
 P1074[0...2], 203  
 P1075[0...2], 203  
 P1076[0...2], 203  
 P1110[0...2], 205  
 P1113[0...2], 205  
 P1124[0...2], 206  
 P1140[0...2], 207  
 P1141[0...2], 207  
 P1142[0...2], 207  
 P1175[0...2], 208  
 P1218[0...2], 211  
 P1230[0...2], 212  
 P1330[0...2], 220  
 P2103[0...2], 237  
 P2104[0...2], 237  
 P2106[0...2], 237  
 P2200[0...2], 243  
 P2220[0...2], 245  
 P2221[0...2], 245  
 P2222[0...2], 245  
 P2223[0...2], 245  
 P2235[0...2], 246  
 P2236[0...2], 246  
 P2241[0...2], 247  
 P2242[0...2], 247  
 P2243[0...2], 247  
 P2244[0...2], 247  
 P2253[0...2], 248  
 P2254[0...2], 248  
 P2264[0...2], 249  
 P2803[0...2], 259  
 P3351[0...2], 274  
 P3852[0...2], 277
- CI
- P0095[0...9], 161  
 P0771[0], 185  
 P1042[0...2], 201  
 P1044[0...2], 201  
 P1070[0...2], 203  
 P1071[0...2], 203  
 P1075[0...2], 203  
 P1076[0...2], 203  
 P1330[0...2], 220  
 P2019[0...7], 232  
 P2151[0...2], 239  
 P2242[0...2], 247  
 P2244[0...2], 247  
 P2253[0...2], 248  
 P2254[0...2], 248  
 P2264[0...2], 249  
 P2869[0...1], 267
- P2871[0...1], 268  
 P2873[0...1], 268  
 P2875[0...1], 268  
 P2877[0...1], 269  
 P2879[0...1], 269  
 P2881[0...1], 269  
 P2883[0...1], 269  
 P2885[0...1], 270  
 P2887[0...1], 270
- Clone saved parameter settings, 302
- CO
- P2378, 256  
 P2889, 270  
 P2890, 270  
 r0020, 154  
 r0021, 155  
 r0024, 155  
 r0025, 155  
 r0026[0], 155  
 r0027, 155  
 r0028, 155  
 r0031, 155  
 r0032, 155  
 r0035[0...2], 155  
 r0036, 155  
 r0037[0...1], 156  
 r0038, 156  
 r0039, 156  
 r0051[0...1], 157  
 r0066, 159  
 r0067, 159  
 r0068, 160  
 r0069[0...5], 160  
 r0070, 160  
 r0071, 160  
 r0072, 160  
 r0074, 160  
 r0078, 160  
 r0080, 161  
 r0084, 161  
 r0085, 161  
 r0086, 161  
 r0087, 161  
 r0395, 173  
 r0512, 174  
 r0623[0...2], 175  
 r0630[0...2], 176  
 r0631[0...2], 176  
 r0632[0...2], 176  
 r0633[0...2], 176  
 r0755[0...1], 183  
 r0947[0...63], 190

r0949[0...63], 192  
 r0954[0...2], 192  
 r0956[0...2], 193  
 r0957[0...2], 193  
 r0958[0...2], 193  
 r1024, 200  
 r1045, 201  
 r1050, 202  
 r1078, 203  
 r1079, 203  
 r1114, 206  
 r1119, 206  
 r1170, 208  
 r1242, 214  
 r1246[0...2], 215  
 r1315, 219  
 r1337, 221  
 r1343, 222  
 r1344, 222  
 r1801[0...1], 223  
 r2018[0...7], 230  
 r2110[0...3], 237  
 r2224, 246  
 r2245, 247  
 r2250, 248  
 r2260, 249  
 r2262, 249  
 r2266, 249  
 r2272, 250  
 r2273, 250  
 r2294, 251  
 r2870, 268  
 r2872, 268  
 r2874, 268  
 r2876, 268  
 r2878, 269  
 r2880, 269  
 r2882, 269  
 r2884, 270  
 r2955, 271  
 r3237.0...1, 272  
**CO/BO**  
 r0019.0...14, 154  
 r0050, 156  
 r0052.0...15, 157  
 r0053.0...15, 157  
 r0054.0...15, 158  
 r0055.0...15, 158  
 r0056.0...15, 159  
 r0722.0...12, 179  
 r0747.0...1, 182  
 r0751.0...9, 182

r0785.0, 186  
 r0955[0...2], 192  
 r1199.7...12, 208  
 r2067.0...12, 236  
 r2197.0...12, 242  
 r2198.0...12, 243  
 r2379.0...2, 257  
 r3113.0...15, 271  
 r3365, 276

**Communication**

MODBUS communication, 138  
 USS communication, 133

**Connecting**

EMC-compliant cabinet design, 47  
 EMC-compliant installation, 45  
 recommended fuses, motor controllers and circuit breakers, 38  
 terminal layout, 40  
 typical system connections, 37  
 wiring diagram, 39

**D**

**DDS**

P0291[0...2], 166  
 P0304[0...2], 167  
 P0305[0...2], 168  
 P0307[0...2], 168  
 P0308[0...2], 168  
 P0309[0...2], 169  
 P0310[0...2], 169  
 P0311[0...2], 169  
 P0314[0...2], 169  
 P0320[0...2], 169  
 P0335[0...2], 170  
 P0340[0...2], 170  
 P0341[0...2], 171  
 P0342[0...2], 171  
 P0344[0...2], 171  
 P0346[0...2], 171  
 P0347[0...2], 172  
 P0350[0...2], 172  
 P0352[0...2], 172  
 P0354[0...2], 172  
 P0356[0...2], 172  
 P0358[0...2], 172  
 P0360[0...2], 173  
 P0604[0...2], 174  
 P0610[0...2], 175  
 P0622[0...2], 175  
 P0625[0...2], 175  
 P0626[0...2], 176

P0627[0...2], 176	P1251[0...2], 215
P0628[0...2], 176	P1252[0...2], 215
P0640[0...2], 176	P1253[0...2], 215
P1001[0...2], 197	P1256[0...2], 216
P1002[0...2], 198	P1257[0...2], 216
P1003[0...2], 198	P1300[0...2], 216
P1004[0...2], 198	P1310[0...2], 217
P1005[0...2], 198	P1311[0...2], 218
P1006[0...2], 198	P1312[0...2], 218
P1007[0...2], 198	P1316[0...2], 219
P1008[0...2], 198	P1320[0...2], 219
P1009[0...2], 198	P1321[0...2], 219
P1010[0...2], 199	P1322[0...2], 219
P1011[0...2], 199	P1323[0...2], 219
P1012[0...2], 199	P1324[0...2], 220
P1013[0...2], 199	P1325[0...2], 220
P1014[0...2], 199	P1333[0...2], 220
P1015[0...2], 199	P1334[0...2], 220
P1016[0...2], 199	P1335[0...2], 220
P1031[0...2], 200	P1336[0...2], 221
P1040[0...2], 201	P1338[0...2], 221
P1047[0...2], 202	P1340[0...2], 221
P1048[0...2], 202	P1341[0...2], 221
P1058[0...2], 202	P1345[0...2], 222
P1060[0...2], 202	P1346[0...2], 222
P1061[0...2], 203	P1350[0...2], 222
P1080[0...2], 204	P1780[0...2], 223
P1082[0...2], 204	P1800[0...2], 223
P1091[0...2], 205	P1803[0...2], 223
P1092[0...2], 205	P1810[0...2], 223
P1093[0...2], 205	P1820[0...2], 224
P1094[0...2], 205	P1909[0...2], 224
P1101[0...2], 205	P2000[0...2], 226
P1120[0...2], 206	P2001[0...2], 227
P1121[0...2], 206	P2002[0...2], 227
P1130[0...2], 207	P2003[0...2], 227
P1131[0...2], 207	P2004[0...2], 228
P1132[0...2], 207	P2150[0...2], 238
P1133[0...2], 207	P2151[0...2], 239
P1134[0...2], 207	P2155[0...2], 239
P1135[0...2], 207	P2156[0...2], 239
P1202[0...2], 209	P2157[0...2], 239
P1227[0...2], 211	P2158[0...2], 239
P1232[0...2], 212	P2159[0...2], 239
P1233[0...2], 212	P2160[0...2], 239
P1234[0...2], 212	P2162[0...2], 239
P1236[0...2], 212	P2164[0...2], 239
P1240[0...2], 214	P2166[0...2], 239
P1243[0...2], 215	P2167[0...2], 239
P1245[0...2], 215	P2168[0...2], 240
P1247[0...2], 215	P2170[0...2], 240
P1250[0...2], 215	P2171[0...2], 240

- P2172[0...2], 240
- P2173[0...2], 240
- P2177[0...2], 240
- P2181[0...2], 240
- P2182[0...2], 241
- P2183[0...2], 241
- P2184[0...2], 241
- P2185[0...2], 241
- P2186[0...2], 242
- P2187[0...2], 242
- P2188[0...2], 242
- P2189[0...2], 242
- P2190[0...2], 242
- P2192[0...2], 242
- P2201[0...2], 243
- P2202[0...2], 244
- P2203[0...2], 244
- P2204[0...2], 244
- P2205[0...2], 244
- P2206[0...2], 244
- P2207[0...2], 244
- P2208[0...2], 244
- P2209[0...2], 244
- P2210[0...2], 245
- P2211[0...2], 245
- P2212[0...2], 245
- P2213[0...2], 245
- P2214[0...2], 245
- P2215[0...2], 245
- P2216[0...2], 245
- P2231[0...2], 246
- P2240[0...2], 246
- P2247[0...2], 248
- P2248[0...2], 248
- P2360[0...2], 252
- P2361[0...2], 253
- P2362[0...2], 253
- P2365[0...2], 253
- P2366[0...2], 253
- P2367[0...2], 254
- P2370[0...2], 254
- P2371[0...2], 254
- P2372[0...2], 255
- P2373[0...2], 255
- P2374[0...2], 255
- P2375[0...2], 256
- P2376[0...2], 256
- P2377[0...2], 256
- P2378[0...2], 256
- P3853[0...2], 277
- P3854[0...2], 277
- r0035[0...2], 155
- r0313[0...2], 169
- r0330[0...2], 169
- r0331[0...2], 170
- r0332[0...2], 170
- r0333[0...2], 170
- r0345[0...2], 171
- r0370[0...2], 173
- r0372[0...2], 173
- r0373[0...2], 173
- r0374[0...2], 173
- r0376[0...2], 173
- r0377[0...2], 173
- r0382[0...2], 173
- r0384[0...2], 173
- r0386[0...2], 173
- r0623[0...2], 175
- r0630[0...2], 176
- r0631[0...2], 176
- r0632[0...2], 176
- r0633[0...2], 176
- r1246[0...2], 215

## F

Fault code list, 282

## I

Inverter functions, 81

Inverter menu structure

- 50/60 Hz selection menu, 59

- Display menu, 53

- Main menu, 51

- Parameter menu, 51, 79

- Setup menu, 61

- Setup menu: application macros sub-menu,

- Setup menu: common parameters sub-menu,

- Setup menu: connection macros sub-menu,

- Setup menu: motor data sub-menu,

Inverter status at fault, 282

## L

List of modified parameters, 82

## M

Macros

- application macros, 75

- connection macros, 64

Mounting

- cabinet panel mounting, 26
- push-through mounting, 30

Mounting orientation and clearance, 25

**O**

Order numbers of inverters, 21

**P**

Parameter resets, 132

Parameters

- access levels, 150
- BICO parameters, 148
- C, C(1), C(30),U, T, 151
- data set, 147
- Digit-by-digit editing, 55
- Normal editing of parameters, 54
- Parameter types, 53
- scaling, 151

**Q**

Quick commissioning

- through the parameter menu, 79
- through the setup menu, 60

**T**

Technical support, 4

Text menu

- for common parameters, 78
- for motor parameters, 62

**U**

User documentation components, 3

