

Industrial Controls

Soft starters and solid-state switching devices 3RW44 soft starters



Equipment Manual

<u>Important notes</u>	1
<u>Introduction</u>	2
<u>Configuration instructions</u>	3
<u>Installation, connection and feeder configuration</u>	4
<u>Display, controls and device interfaces</u>	5
<u>Commissioning</u>	6
<u>Device functions</u>	7
<u>Diagnostics and messages</u>	8
<u>PROFIBUS DP communication module</u>	9
<u>Typical circuit diagrams</u>	10
<u>General technical data</u>	11
<u>Appendix</u>	A

Legal information

Warning notice system

This manual contains notices you have to observe in order to ensure your personal safety, as well as to prevent damage to property. The notices referring to your personal safety are highlighted in the manual by a safety alert symbol, notices referring only to property damage have no safety alert symbol. These notices shown below are graded according to the degree of danger.

 DANGER
indicates that death or severe personal injury will result if proper precautions are not taken.
 WARNING
indicates that death or severe personal injury may result if proper precautions are not taken.
 CAUTION
indicates that minor personal injury can result if proper precautions are not taken.
NOTICE
indicates that property damage can result if proper precautions are not taken.

If more than one degree of danger is present, the warning notice representing the highest degree of danger will be used. A notice warning of injury to persons with a safety alert symbol may also include a warning relating to property damage.

Qualified Personnel

The product/system described in this documentation may be operated only by **personnel qualified** for the specific task in accordance with the relevant documentation, in particular its warning notices and safety instructions. Qualified personnel are those who, based on their training and experience, are capable of identifying risks and avoiding potential hazards when working with these products/systems.

Proper use of Siemens products

Note the following:

 WARNING
Siemens products may only be used for the applications described in the catalog and in the relevant technical documentation. If products and components from other manufacturers are used, these must be recommended or approved by Siemens. Proper transport, storage, installation, assembly, commissioning, operation and maintenance are required to ensure that the products operate safely and without any problems. The permissible ambient conditions must be complied with. The information in the relevant documentation must be observed.

Trademarks

All names identified by ® are registered trademarks of Siemens AG. The remaining trademarks in this publication may be trademarks whose use by third parties for their own purposes could violate the rights of the owner.

Disclaimer of Liability

We have reviewed the contents of this publication to ensure consistency with the hardware and software described. Since variance cannot be precluded entirely, we cannot guarantee full consistency. However, the information in this publication is reviewed regularly and any necessary corrections are included in subsequent editions.

Table of contents

1	Important notes	9
1.1	Support Request.....	10
1.2	Security information	11
2	Introduction	13
2.1	Basic physical principles of the three-phase asynchronous motor and operating principle of the soft starter	13
2.1.1	Three-phase asynchronous motor	13
2.1.2	Principle of operation of the 3RW44 electronic soft starter	16
2.2	Application and use.....	19
2.3	Marginal conditions for storage and operation	20
3	Configuration instructions	21
3.1	Configuration.....	21
3.1.1	RS 232 serial PC interface and Soft Starter ES parameterizing and operating software	21
3.1.2	Simulation Tool for Soft Starters (STS)	21
3.2	Startup class	22
3.2.1	Application examples for normal starting (CLASS 10)	23
3.2.2	Application examples for heavy starting (CLASS 20).....	24
3.2.3	Application examples for very heavy starting (CLASS 30).....	25
3.3	ON time and switching frequency	26
3.4	Installation altitude and ambient temperature.....	27
3.5	Factory settings.....	28
3.6	Article number system for SIRIUS 3RW44 soft starters	29
4	Installation, connection and feeder configuration	31
4.1	Installing the soft starter.....	31
4.1.1	Unpacking	31
4.1.2	Mounting position.....	31
4.1.3	Installation requirements.....	32
4.1.4	Mounting dimensions and clearances	33
4.2	Design of the feeder.....	34
4.2.1	General information	34
4.2.2	Soft starters in standard circuits	35
4.2.3	Soft starters in inside-delta circuits	36
4.2.4	Soft starter with contactor disconnecter (main contactor)	39
4.3	Protection of the soft starter against short-circuits (type of assignment 2).....	41
4.4	Capacitors for improving the power factor	43
4.5	Generator operation with three-phase asynchronous motor	43

4.6	Electrical connection	44
4.6.1	Control and auxiliary circuit connection	44
4.6.2	Main circuit connection	44
4.6.3	Conductor cross-sections	46
5	Display, controls and device interfaces.....	49
5.1	Display and controls.....	49
5.2	Device interfaces.....	51
5.2.1	Local device interface	51
5.2.2	PROFIBUS/PROFINET interface (optional)	51
5.3	External display and control module (optional).....	51
6	Commissioning	53
6.1	Menu structure, navigation, changing parameters.....	53
6.1.1	Menu structure and navigation.....	53
6.1.2	Changing parameters: for example motor data	54
6.2	Switching on for the first time.....	55
6.2.1	Recommended procedure for commissioning 3RW44	55
6.2.2	Quick start menu, when switching on for the first time	56
6.2.3	Problems that can occur	58
6.2.4	Quick Start menu	61
6.3	User-specific commissioning	63
6.3.1	Settings main menu item	64
6.4	Making settings in the selected parameter set	65
6.4.1	Selecting the parameter set.....	65
6.4.2	Entering the motor data	66
6.4.3	Specifying the startup mode	68
6.4.4	Specifying the coasting method	80
6.4.5	Setting slow speed parameters.....	91
6.4.6	Specifying current limit values	93
6.4.7	Parameterizing the inputs	94
6.4.8	Parameterizing the outputs	97
6.4.9	Selecting motor protection settings.....	99
6.4.10	Selecting display settings.....	102
6.4.11	Specifying the behavior of the protective functions	103
6.4.12	Specifying the names on the device display	105
6.4.13	Activating the fieldbus interface (PROFIBUS DP/PROFINET IO).....	106
6.4.14	Saving options.....	107
6.5	Other device functions	112
6.5.1	Measured values display	112
6.5.2	Status display.....	114
6.5.3	Motor control (assigning control priority).....	115
6.5.4	Statistics	117
6.5.5	Safety (specifying the user level, parameterization protection)	123

7	Device functions.....	125
7.1	Various parameter sets.....	125
7.1.1	Various parameter sets.....	125
7.2	Startup modes.....	126
7.2.1	Voltage ramp.....	126
7.2.2	Torque control.....	128
7.2.3	Breakaway pulse in combination with the voltage ramp or torque control startup mode	130
7.2.4	Current limitation in combination with the voltage ramp or torque control startup mode	132
7.2.5	Direct startup mode.....	134
7.2.6	Motor heating startup mode.....	134
7.3	Coasting methods	135
7.3.1	Coasting down	136
7.3.2	Torque control and pump stop.....	136
7.3.3	DC braking/combined braking	138
7.4	Slow speed function.....	141
7.5	Current limits for load monitoring.....	143
7.6	Motor protection functions	143
7.7	Intrinsic device protection	147
7.7.1	Intrinsic device protection	147
8	Diagnostics and messages	149
8.1	Diagnostics and messages.....	149
8.1.1	Status messages	149
8.1.2	Warnings and group faults	150
8.1.3	Device fault	156
9	PROFIBUS DP communication module.....	159
9.1	Introduction	159
9.1.1	Definitions	161
9.2	Data transfer	162
9.2.1	Options for data transfer	162
9.2.2	Communication principle	163
9.3	Installing the PROFIBUS DP communication module.....	164
9.3.1	Inserting the PROFIBUS DP communication module (fieldbus interface).....	164
9.4	Activating the PROFIBUS DP communication module (fieldbus interface) and setting the station address.....	166
9.4.1	Introduction	166
9.4.2	Activating the PROFIBUS DP communication module via the display, setting the station address and saving the settings.....	167
9.4.3	Activating the PROFIBUS DP communication module (fieldbus interface) and setting the station address via the device interface using the "Soft Starter ES Premium" or the "Soft Starter ES Smart + SP1" software	170

9.5	Configuring soft starters	172
9.5.1	Introduction	172
9.5.2	Configuring with the GSD file	173
9.5.3	Configuring with the Soft Starter ES Professional software	174
9.5.4	Diagnostics package	174
9.5.5	Soft Starter ES parameterization software	174
9.6	PROFIBUS DP commissioning using the GSD file in STEP 7 (example)	175
9.6.1	Introduction	175
9.6.2	Configuration using the Device Master Data (GSD) in STEP 7	176
9.6.3	Integration into the user program	178
9.6.4	Switching on	179
9.6.5	Flow diagram: PROFIBUS DP starting the soft starter	180
9.7	Process data and process images	181
9.8	Diagnosis via LED display	182
9.9	Diagnosis with STEP 7	183
9.9.1	Reading out the diagnostic data	183
9.9.2	Options for reading diagnostic data	183
9.9.3	Structure of the slave diagnostics	184
9.9.4	Station status 1 to 3	185
9.9.5	Master PROFIBUS address	187
9.9.6	Manufacturer ID	187
9.9.7	ID-related diagnostics	188
9.9.8	Module status	189
9.9.9	Channel-related diagnostics	190
9.10	Data formats and data sets	192
9.10.1	Properties	192
9.11	Identification number (ID No.), error codes	196
9.11.1	Identification number (ID No.)	196
9.11.2	Error codes for negative data set acknowledgement	196
9.12	Data sets (BS)	198
9.12.1	Data set 68 - Reading/writing the process image of the outputs	199
9.12.2	Data set 69 - Reading the process image of the inputs	200
9.12.3	Data set 72 - Logbook - Reading device errors	201
9.12.4	Data set 73 - Logbook - Reading the trips	202
9.12.5	Data set 75 - Logbook - Reading events	204
9.12.6	Data set 81 - Reading the basic settings of data set 131	205
9.12.7	Data set 82 - Reading the basic settings of data set 132	205
9.12.8	Data set 83 - Reading the basic settings of data set 133	206
9.12.9	Data set 92 - Reading device diagnostics	206
9.12.10	Data set 93 - Writing a command	212
9.12.11	Data set 94 - Reading measured values	213
9.12.12	Data set 95 - Reading statistical data	214
9.12.13	Data set 96 - Reading the maximum pointer	215
9.12.14	Data set 100 - Reading the device identification	217
9.12.15	Data sets 131, 141, 151 - Technology parameters 2: Reading/writing sets 1, 2, 3	219
9.12.16	Data sets 132, 142, 152 - Technology parameters 3: Reading/writing sets 1, 2, 3	224
9.12.17	Data set 133 - Technology parameters 4: HMI module	225
9.12.18	Data set 160 - Reading/writing communication parameters	226
9.12.19	Data set 165 - Reading/writing comments	227

10	Typical circuit diagrams	229
10.1	Connection examples for main and control circuits	229
10.1.1	3RW44 in a standard circuit with control via keys	229
10.1.2	3RW44 in a standard circuit with line contactor and control via PLC	231
10.1.3	3RW44 in a standard circuit and DC braking stopping function for device types 3RW44 22 to 3RW44 25	232
10.1.4	3RW44 in a standard circuit and DC braking stopping function for device types 3RW44 26 to 3RW44 66	233
10.1.5	3RW44 in an inside-delta circuit	234
10.1.6	3RW44 in a standard circuit and control like a contactor	236
10.1.7	3RW44 in a standard circuit with soft start/stop and additional slow speed function in both directions of rotation with one parameter set.....	237
10.1.8	Control via @PROFIBUS with switchover to manual local operation (e.g. on the control cabinet)	239
10.1.9	3RW44 in a standard circuit and reversing operation via main contactors with one parameter set without soft stopping.....	240
10.1.10	Reversing operation with soft stopping.....	242
10.1.11	Soft starter for pole-changing motor with separate windings and 2 parameter sets	243
10.1.12	Soft starter for Dahlander motors with 2 parameter sets	245
10.1.13	Parallel starting of 3 motors	247
10.1.14	Soft starter for serial starting with 3 parameter sets	249
10.1.15	Soft starter for serial starting with 3 parameter sets (deactivate soft stop and 3RW44 motor protection).....	251
10.1.16	Soft starter for activation of a motor with a magnetic fixing brake	252
10.1.17	Safe disconnection according to IEC 62061 (SIL) and/or ISO 13849-1 (PL)	253
10.1.18	Soft starter with direct-on-line starting (DOL) as emergency start	254
10.1.19	Soft starter with star-delta starter as emergency start (3RW44 in a standard circuit)	255
10.1.20	Soft starter and frequency converter on one motor	256
11	General technical data	257
11.1	Menu structure	257
11.2	Transport and storage conditions	267
11.3	Technical data.....	268
11.3.1	Selection and ordering data	268
11.3.2	Technical data of the power unit.....	274
11.3.3	Technical data of the control section	279
11.3.4	Conductor cross-sections	283
11.3.5	Electromagnetic compatibility	285
11.3.6	Feeder component layout (standard circuit)	286
11.3.7	Feeder component layout (inside-delta circuit).....	291
11.3.8	Accessories.....	293
11.3.9	Spare parts	296
11.4	Tripping characteristics	297
11.4.1	Motor protection tripping characteristics: 3RW44 with symmetry.....	297
11.4.2	Motor protection tripping characteristics: 3RW44 with asymmetry.....	298
11.5	Dimension drawings.....	299
11.5.1	Dimension drawings.....	299

A	Appendix	305
	Index	307

Important notes

Purpose of this manual

This manual contains fundamental information and practical tips for using SIRIUS 3RW44 soft starters. The SIRIUS 3RW44 soft starter is an electronic motor control device that enables optimized starting and stopping of three-phase asynchronous motors. This manual describes all the functions of the SIRIUS 3RW44 soft starter.

Target group

This manual is intended for any user involved in

- Commissioning
- Servicing and maintenance
- Planning and configuring systems

Basic knowledge required

A general knowledge of the field of electrical engineering is required to understand this manual.

Validity

This manual is valid for SIRIUS 3RW44 soft starters. It contains a description of the components that are valid at the time of publication of this manual. SIEMENS reserves the right to include updated information about new components or new versions of components in a Product Information.

Definitions

Where the short form 3RW44 is used in the text, it refers to the SIRIUS 3RW44 soft starter.

Standards and approvals

The SIRIUS 3RW44 soft starter is based on IEC/EN 60947-4-2.

1.1 Support Request

Disclaimer of liability

The manufacturer of the system or machine is responsible for ensuring the correct overall functioning. SIEMENS AG, its regional offices, and associated companies (hereinafter referred to as "SIEMENS") cannot guarantee all the properties of a system or machine not designed by SIEMENS.

Nor can Siemens assume liability for recommendations given or implied by the following description. No new guarantee, warranty, or liability claims beyond the scope of the SIEMENS general terms and conditions of supply are to be derived or inferred from the following description.

Access aids

To facilitate and speed up access to special information, the manual contains the following aids:

- At the beginning of the manual you will find a table of contents.
- The individual chapters contain subheadings that provide an overview of the contents of the section.
- At the end of the manual, there is an extensive index to enable you to quickly access the required information.

Up-to-the-minute information at all times

Your regional contacts for communication-capable low-voltage controls will be pleased to assist you with any queries you have regarding the motor starters. A list of contacts and the latest version of the manual are available on the Internet (<http://www.siemens.com/softstarter>).

1.1 Support Request

Use the Support Request online form to send your question directly to Technical Support:

Support Request:	Internet (https://support.industry.siemens.com/My/ww/en/requests)
------------------	--

1.2 Security information

Siemens provides products and solutions with industrial security functions that support the secure operation of plants, systems, machines and networks.

In order to protect plants, systems, machines and networks against cyber threats, it is necessary to implement – and continuously maintain – a holistic, state-of-the-art industrial security concept. Siemens' products and solutions constitute one element of such a concept.

Customers are responsible for preventing unauthorized access to their plants, systems, machines and networks. Such systems, machines and components should only be connected to an enterprise network or the internet if and to the extent such a connection is necessary and only when appropriate security measures (e.g. firewalls and/or network segmentation) are in place.

For additional information on industrial security measures that may be implemented, please visit

<https://www.siemens.com/industrialsecurity>.

Siemens' products and solutions undergo continuous development to make them more secure. Siemens strongly recommends that product updates are applied as soon as they are available and that the latest product versions are used. Use of product versions that are no longer supported, and failure to apply the latest updates may increase customer's exposure to cyber threats.

To stay informed about product updates, subscribe to the Siemens Industrial Security RSS Feed under

<https://www.siemens.com/industrialsecurity>.

Introduction

2.1 Basic physical principles of the three-phase asynchronous motor and operating principle of the soft starter

2.1.1 Three-phase asynchronous motor

Application areas of the three-phase asynchronous motor

Three-phase asynchronous motors are used in a wide range of applications in commerce, industry and trade owing to their simple, rugged design and their low-maintenance operation.

Problem

If a three-phase asynchronous motor is started directly, its typical current and torque characteristics can cause disturbances in the supply system and the load machine.

Starting current

Three-phase asynchronous motors have a high direct starting current $I_{(startup)}$. Depending on the motor version it can amount to between three times and fifteen times the rated operational current. Seven to eight times the rated motor current can be taken as a typical value.

Disadvantage

This results in the following disadvantage:

- Higher load on the electrical supply system. This means that the supply system must be dimensioned for this higher output during the motor startup.



Figure 2-1 Typical starting current characteristic of a three-phase asynchronous motor

Locked-rotor torque

The starting torque and the breakdown torque can usually be assumed to be between two and four times the rated torque. For the load machine this means that the starting and acceleration forces in relation to rated operation give rise to a higher mechanical load on the machine and the conveyed material.

Disadvantages

This results in the following disadvantages

- A higher load is placed on the machine's mechanical components
- Higher costs for replacing worn parts and maintaining the application

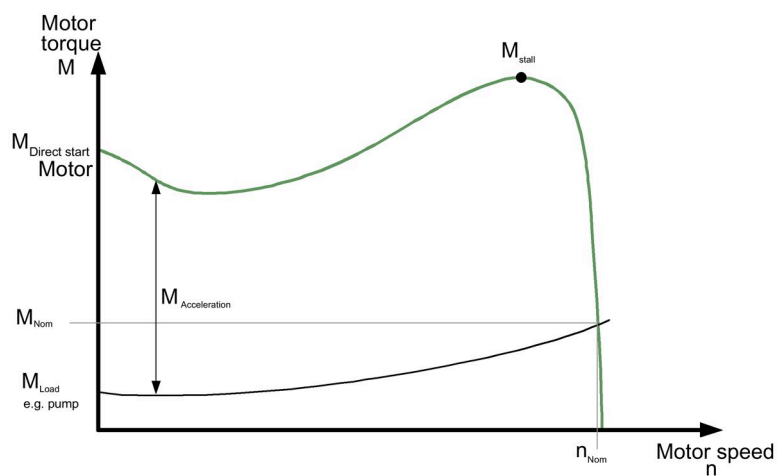

Figure 2-2 Typical starting torque characteristic of a three-phase asynchronous motor

Solution

The SIRIUS 3RW44 electronic soft starter allows the current and torque characteristics during startup to be optimally adapted to the requirements of each application.

2.1.2 Principle of operation of the 3RW44 electronic soft starter

The 3RW44 soft starter features two antiparallel thyristors in each of the phases. There is one thyristor for the positive and one thyristor for the negative half-wave.

The rms value of the motor voltage is increased (from an adjustable starting voltage or starting torque) to the rated motor voltage within a definable starting time by means of the leading-edge phase. This is achieved using various control methods.

The motor current changes in proportion to the voltage applied to the motor. The starting current is thus reduced by the factor of the voltage applied to the motor.

The torque changes in squared proportion to the voltage applied to the motor. The starting torque is thus reduced in squared proportion to the voltage applied to the motor.

Example

SIEMENS 1LG4253AA motor (55 kW)

Rated data at 400 V

P_e :	55 kW
I_e :	100 A
$I_{\text{direct starting}}$:	approx. 700 A
M_e :	355 Nm

Example:

$$M_e = 9,55 \times 55 \text{ kW} \times \frac{1000}{1480 \text{ min}^{-1}}$$

n_e :	1480 rpm
$M_{\text{direct starting}}$:	approx. 700 Nm
Set starting voltage:	50 % ($\frac{1}{2}$ of line voltage)

=> I_{starting} $\frac{1}{2}$ of direct-on-line starting switch-on current (approx. 350 A)

=> M_{starting} $\frac{1}{4}$ of direct-on-line starting torque (approx. 175 Nm)

2.1 Basic physical principles of the three-phase asynchronous motor and operating principle of the soft starter

The diagrams below show the starting current and torque characteristics for a three-phase asynchronous motor in combination with a soft starter:

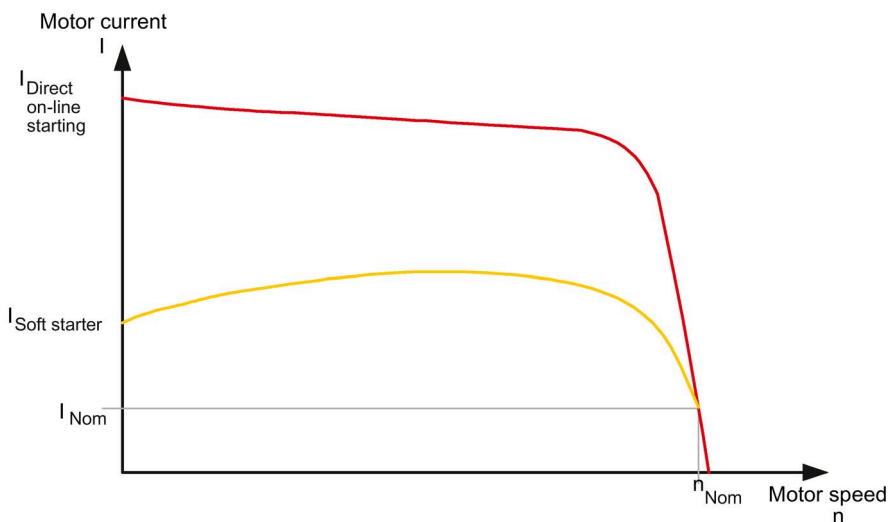

Figure 2-3 Reduced current characteristic of a three-phase asynchronous motor during startup with a SIRIUS 3RW44 soft starter

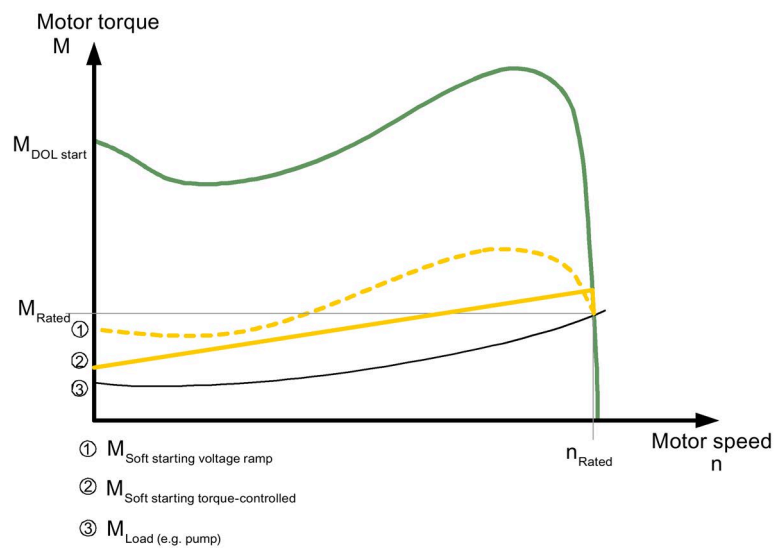

Figure 2-4 Reduced torque characteristic of a three-phase asynchronous motor during startup with a SIRIUS 3RW44 soft starter

Startup

This means that, since the motor voltage is controlled by the electronic soft starter during the startup process, the consumed starting current and the starting torque generated in the motor are also controlled.

The same principle is applied during the stopping process. This way the torque generated in the motor is slowly reduced, thus enabling a smooth ramp-down of the application.

The frequency remains constant during this process and corresponds to the line frequency, in contrast to frequency-controlled startup and stopping of a frequency converter.

Once the motor has started up correctly, the thyristors are fully utilized, meaning that the complete line voltage is applied to the motor terminals. As the motor voltage does not have to be controlled during operation, the thyristors are bridged by integrated bypass contacts. This minimizes the waste heat generated during continuous operation (which is caused by the thyristor's power loss). Therefore the area around the switching devices heats up less.

The diagram below shows the method of operation of the 3RW44 soft starter:

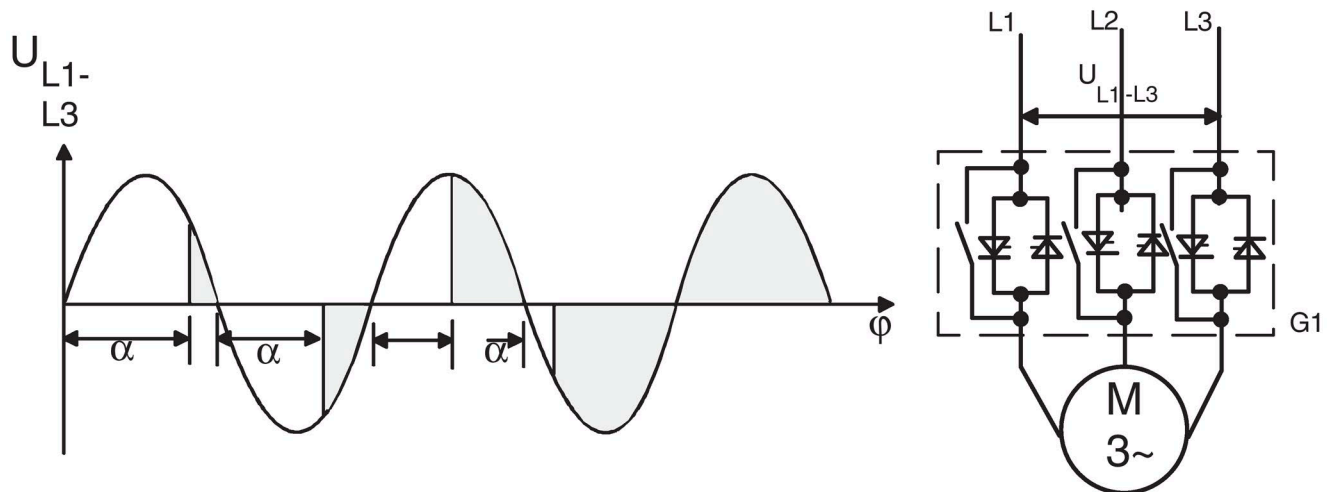

Figure 2-5 Phase angle control and schematic diagram of a soft starter with internal bypass contacts

2.2 Application and use

Applications and selection criteria

3RW44 soft starters can be used as an alternative to star-delta (wye-delta) starters and frequency converters.

Their main benefits are their ability to perform soft starting, soft stops, and uninterrupted changeover without current peaks that put a strain on the system, as well as their compact dimensions.

Many drives that could previously only be operated with frequency converters can be changed over to soft starter operation using the 3RW44 soft starter, provided no speed control, no particularly high starting torque, or startup with close to rated current, is required.

Applications

Typical applications include:

- Conveyor belts
- Roller conveyors
- Compressor
- Ventilators, fans
- Pump
- Hydraulic pumps
- Stirrers
- Centrifuges
- Milling machines
- Mills
- Crushers
- Circular saws/bandsaws
- ...

Advantages

Conveyor belts, conveyor systems:

- Smooth starting
- Smooth braking

Rotary pumps, piston pumps:

- No pressure surges
- Increased service life of the pipe system

Agitators, mixers:

- Reduced starting current

Fans:

- Reduced stress on gearbox and V belt

2.3 Marginal conditions for storage and operation

Permissible ambient temperature for	
- Storage	-25 °C ... +80 °C
- Operation	0 °C ... +60 °C, from 40 °C with derating (refer to chapter Technical data (Page 268))
Permissible relative humidity	10 ... 95 %
Permissible maximum installation altitude	5000 m, from 1000 m with derating

NOTICE

Risk of property damage.

Make sure no liquids, dust, or conductive objects can get inside the soft starter.

Configuration instructions

3.1 Configuration

The 3RW44 electronic soft starters are designed for normal starting. In case of heavy starting or increased starting frequency, a larger unit may have to be selected.

For long starting times it is recommended to have a PTC sensor in the motor. This also applies to soft stop, pump stop and DC braking coasting methods because, during the coast-down time in these modes, an additional current loading applies in contrast to coasting down.

The motor feeder between the soft starter and motor must not contain any capacitive elements (such as compensation systems). Active filters must not be operated in combination with soft starters.

All elements of the main circuit (such as fuses and switching devices) should be dimensioned for direct-on-line starting, following the local short-circuit conditions, and must be ordered separately.

The harmonic component load for starting currents must be taken into consideration for the selection of motor starter protectors (selection of trip unit).

3.1.1 RS 232 serial PC interface and Soft Starter ES parameterizing and operating software

The electronic 3RW44 soft starters have a PC interface for communicating with the Soft Starter ES smart software and an operating and monitoring module (display).

3.1.2 Simulation Tool for Soft Starters (STS)

With this software, you can simulate and select all Siemens soft starters, taking into account various parameters such as line conditions, motor and load data, and special application requirements, etc.

The Simulation Tool for Soft Starters (STS) can be downloaded from the Internet (<https://support.industry.siemens.com/cs/ww/en/view/101494917>).

3.2 Startup class

To achieve the optimum soft starter design, it is important to know and take into account the starting time (startup class) of the application. Long starting times mean a higher thermal load on the thyristors of the soft starter. 3RW44 soft starters are designed for continuous operation under normal starting conditions (CLASS 10), an ambient temperature of 40 °C, and a fixed switching frequency. You will also find these values in chapter Technical data of the power unit (Page 274). If deviations from this data occurs, the starters may need to be overdimensioned.

Selection criteria

Note

You must select the size of your SIRIUS 3RW44 soft starters according to the rated motor current (rated current_{soft starter} ≥ rated motor current).

Note

For the correct dimensioning of soft starters for motors with high starting current ratios (typically $I/I_e \geq 8$), we recommend our Simulation Tool for Soft Starters (STS).

3.2.1 Application examples for normal starting (CLASS 10)

Normal starting CLASS 10 (up to 20 s with 350 % $I_{n \text{ motor}}$)

The soft starter rating can be selected to be as high as the rating of the motor implemented.

Application	Conveyor belts	Roller conveyors	Compressor	Small fans	Pump	Hydraulic pumps
Starting parameters						
Voltage ramp and current limiting						
• Starting voltage %	70	60	50	30	30	30
• Starting time s	10	10	10	10	10	10
• Current limiting value	Deactivated	Deactivated	4 x I_M	4 x I_M	Deactivated	Deactivated
Torque ramp						
• Starting torque	60	50	40	20	10	10
• End torque	150	150	150	150	150	150
• Starting time	10	10	10	10	10	10
Breakaway pulse	Deactivated (0 ms)	Deactivated (0 ms)	Deactivated (0 ms)	Deactivated (0 ms)	Deactivated (0 ms)	Deactivated (0 ms)
Coasting method	Soft stop	Soft stop	Coasting down	Coasting down	Pump stop	Coasting down

3.2 Startup class

3.2.2 Application examples for heavy starting (CLASS 20)

Heavy starting CLASS 20 (up to 40 s with 350 % $I_{n \text{ motor}}$)

The soft starter has to be selected one power class higher than that of the implemented motor.

Application	Stirrers	Centrifuges	Milling machines
Starting parameters			
Voltage ramp and current limiting			
• Starting voltage %	30	30	30
• Starting time s	30	30	30
• Current limiting value	4 x I_M	4 x I_M	4 x I_M
Torque ramp			
• Starting torque	30	30	30
• End torque	150	150	150
• Starting time	30	30	30
Breakaway pulse	Deactivated (0 ms)	Deactivated (0 ms)	Deactivated (0 ms)
Coasting method	Coasting down	Coasting down	Coasting down or DC braking

3.2.3 Application examples for very heavy starting (CLASS 30)

Heavy starting CLASS 30 (up to 60 s with 350 % I_n motor)

The soft starter has to be selected two power classes higher than that of the implemented motor.

Application	Large fans	Mills	Crushers	Circular saws/bandsaws
Starting parameters				
Voltage ramp and current limiting				
• Starting voltage %	30	50	50	30
• Starting time s	60	60	60	60
• Current limiting value	4 x I_M	4 x I_M	4 x I_M	4 x I_M
Torque ramp				
• Starting torque	20	50	50	20
• End torque	150	150	150	150
• Starting time	60	60	60	60
Breakaway pulse	Deactivated (0 ms)	80 %; 300 ms	80 %; 300 ms	Deactivated (0 ms)
Coasting method	Coasting down	Coasting down	Coasting down	Coasting down

Note

The settings and device dimensions indicated in these tables are examples only; they are merely provided for information purposes and are not binding. Set values depend on the application in question and must be optimized during commissioning.

3.3 ON time and switching frequency

Based on the rated motor current and the startup class, the 3RW44 soft starters are dimensioned for a maximum permissible switching frequency in combination with a relative ON time. See also Chapter Technical data of the power unit (Page 274). A larger soft starter may have to be selected if these values are exceeded.

ON time motor OT

The relative ON time in % is the ratio between the load duration and the cycle duration for loads that are frequently switched on and off.

The ON time OT can be calculated using the following formula:

$$OT = \frac{t_s + t_b}{t_s + t_b + t_p}$$

Explanation of the formula:

OT = ON time [%]

t_s = starting time [s]

t_b = operating time [s]

t_p = idle time [s]

The following diagram illustrates this process.

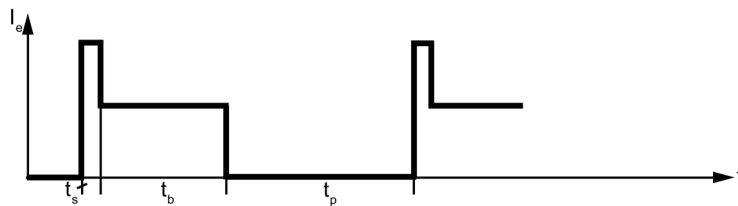

Figure 3-1 ON time motor OT

Switching frequency

The maximum permissible switching frequency must not be exceeded because the devices could be damaged due to thermal overloading.

3.4 Installation altitude and ambient temperature

The permissible installation altitude must not exceed 5000 m above sea level (above 5000 m on request).

If the installation altitude exceeds 1000 m, the rated operational current must be reduced for thermal reasons.

If the installation altitude exceeds 2000 m, the rated voltage must also be reduced owing to the limited dielectric strength. A maximum permissible rated voltage of ≤ 480 V applies at installation altitudes between 2000 m and 5000 m above sea level.

The following diagram shows the reduction in the rated device current as a function of the installation altitude:

The rated operational current I_e must be reduced at altitudes higher than 1000 m above sea level.

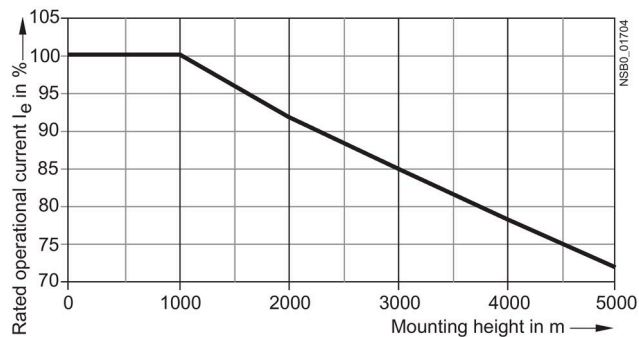

Figure 3-2 Reduction as a function of the installation altitude

Ambient temperature

3RW44 soft starters are designed for operation with rated current at an ambient temperature of 40 °C. If this temperature is exceeded, e.g. owing to an impermissible temperature rise in the control cabinet, other loads, or a general increase in the ambient temperature, the resulting deterioration in the soft starter's performance must be taken into account when the device is dimensioned (see chapter Technical data of the power unit (Page 274)).

3.5 Factory settings

Reset to the factory settings (default)

- if parameter settings are incorrect
- if continued use is to be made of already parameterized SIRIUS 3RW44 soft starters in other systems.

Note

Otherwise, drives could break away in certain circumstances due to existing parameter assignments.

Soft starters already parameterized by users can be reset to the factory settings without the need for additional tools.

For details of how to reset a soft starter to the factory settings, see "Restoring the delivery condition (factory settings)" in chapter Saving options (Page 107).

3.6 Article number system for SIRIUS 3RW44 soft starters

3RW4*	4*	22	-	6	B*	C*	4	4
I	II	III		IV	V	VI	VII	VIII

* Fields are not configurable

I	Identifier of the basic unit AC semiconductor motor control device (soft starter)						
II	Device version: 4 High-End soft starter						
II	Rated operational power P_e (at U_e 400 V)						
I	Rated operational current I_e (for utilization category AC-53a) (at 40°C ambient temperature)						
		P_e	I_e		P_e	I_e	
	22	15 kW	29 A		45	160 kW	313 A
	23	18.5 kW	36 A		46	200 kW	356 A
	24	22 kW	47 A		47	250 kW	432 A
	25	30 kW	57 A		53	315 kW	551 A
	26	37 kW	77 A		54	355 kW	615 A
	27	45 kW	93 A		55	400 kW	693 A
	34	55 kW	113 A		56	450 kW	780 A
	35	75 kW	134 A		57	500 kW	880 A
	36	90 kW	162 A		58	560 kW	970 A
	43	110 kW	203 A		65	630 kW	1076 A
	44	132 kW	250 A		66	710 kW	1214 A

IV	Type of connection	
	1	Standard screwed connection (main/auxiliary conductor connection) (for units \leq 3RW4427)
	2	Main conductors: busbar connection/auxiliary conductors: Spring-loaded terminal (for units $>$ 3RW4427)
	3	Main conductors: screwed connection/auxiliary conductors: Spring-loaded terminal (for units \leq 3RW4427)
	6	Main conductors: busbar connection/auxiliary conductors: Screw terminal (for units $>$ 3RW4427)

3.6 Article number system for SIRIUS 3RW44 soft starters

V	Special function	
	B	With bypass
VI	Number of controlled phases	
	C	All 3 phases controlled
VII	Rated control supply voltage U_s:	
	3	115 V AC
	4	230 V AC
VIII	Rated control supply voltage U_e:	
	4	200 to 460 V
	5	400 to 600 V
	6	400 to 690 V

Installation, connection and feeder configuration

4.1 Installing the soft starter

4.1.1 Unpacking

NOTICE

Do not lift the device by the cover when unpacking it as this could lead to damage.

4.1.2 Mounting position

The soft starter is mounted vertically on vertical, level surfaces.

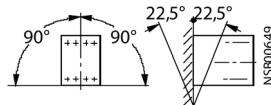

Figure 4-1 Mounting position

4.1 Installing the soft starter

4.1.3 Installation requirements

Degree of protection IP00

3RW44 soft starters conform to IP00 degree of protection.

The devices must be installed in control cabinets with IP54 degree of protection (pollution degree 2), taking account of the ambient conditions.

Make sure no liquids, dust or conductive objects can get inside the soft starter. The soft starter produces waste heat (power loss) while it is operating (refer to chapter General technical data (Page 257)).

NOTICE
Overheating of the switching device
Provide adequate cooling at the place of installation to prevent the switching device from overheating.

Note

Coated circuit boards

All 3RW44 soft starters with a production date G/150206 onwards are equipped as standard with coated printed circuit boards to improve protection of the device against tough ambient conditions such as dust, moisture or other harmful influences.

4.1.4 Mounting dimensions and clearances

The minimum clearances to other devices must be complied with to ensure unobstructed cooling as well as the free supply and discharge of air to and from the heat sink.

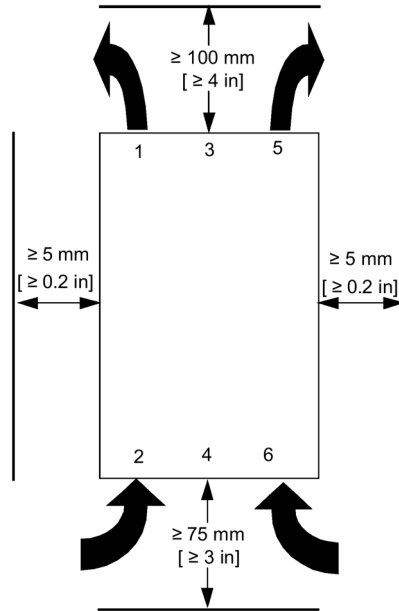

Figure 4-2 Clearance to other devices

NOTICE

Allow sufficient clearances for the cooling air to circulate freely. The device is ventilated from bottom to top.

4.2 Design of the feeder

4.2.1 General information

 **WARNING**

Automatic restart

Can result in death, serious injury, or property damage.

The automatic reset mode must not be used in applications where there is a risk of serious injury to persons or substantial damage to property if the motor starts up again unexpectedly.

The start command (e.g. issued by the PLC) must be reset prior to issuing a reset command, because the motor attempts to restart again automatically if a start command is still active following this reset command. This particularly applies if the motor protection has tripped. For safety reasons, you are advised to integrate the group fault output (terminals 95 and 96) in the controller.

General information

A motor feeder comprises at least a **disconnecter**, a **contact element**, and a **motor**.

Line protection against short-circuits must be implemented, together with overload protection for the line and motor.

Disconnecter

The isolating function with line protection against overload and short-circuits can be achieved with a motor starter protector or a fuse disconnecter, for instance.

(For details of fuse and circuit breaker assignment, refer to chapter Feeder component layout (standard circuit) (Page 286) and chapter Feeder component layout (inside-delta circuit) (Page 291).

Contact element

The 3RW44 soft starter performs the functions of the contact element and motor protection.

 **DANGER**

Hazardous voltage.

Danger to life or risk of serious injury.

If line voltage is present at the input terminals of the soft starter, hazardous voltage may still be present at the soft starter output even if a start command has not been issued. This voltage must be isolated by means of a disconnecter (open isolating distance, e.g. with an open switch disconnecter) whenever work is carried out on the feeder.

4.2.2 Soft starters in standard circuits

The SIRIUS 3RW44 soft starter is connected into the motor feeder between the disconnecter or motor starter protector and the motor.

The 3RW44 soft starter automatically detects the type of connection of the soft starter, meaning that this does not have to be explicitly set on the device. The detected connection type can be read on the starter in the "Status display/Type of connection" menu item. In this case, the display reads "Star/delta". If the circuitry is faulty or the motor is not connected, the display shows "Unknown".

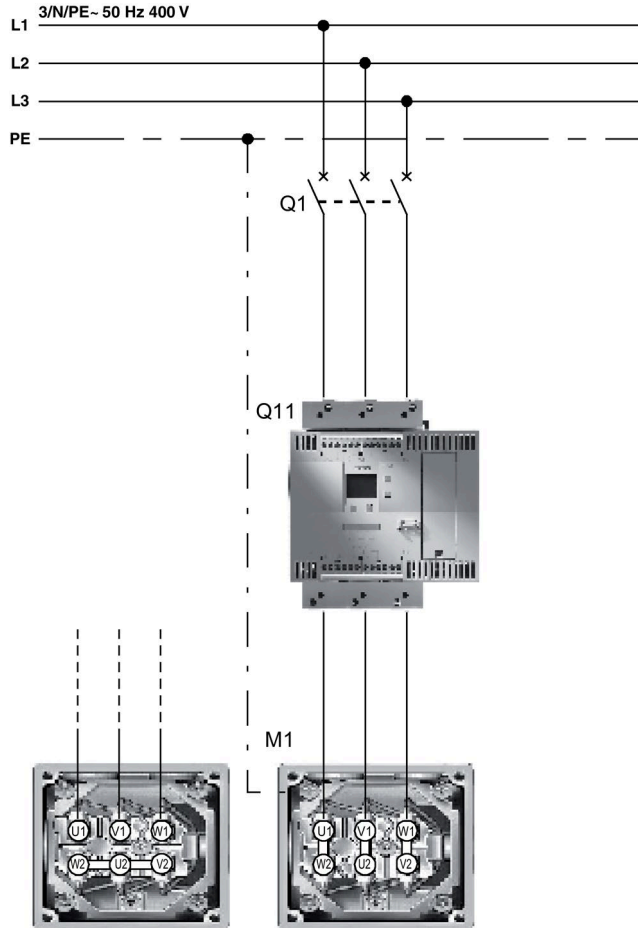

Figure 4-3 Block diagram of 3RW44 soft starters in standard circuits

<p>NOTICE</p> <p>Error message due to delayed switching of the contactor</p> <p>If a main or line contactor is connected between the soft starter and the motor or in the return line between the motor and the soft starter, steps must be taken to ensure that this contactor is connected within 100 ms of activation of the start command for the 3RW44.</p> <p>If the contactor is not connected within 100 ms of activation of the start command for the 3RW44, the soft starter no longer recognizes the current circuit variant (standard circuit or inside-delta circuit). A "Missing load phase 1-3" error message is generated.</p>
--

4.2.3 Soft starters in inside-delta circuits

Requirements

A motor whose windings can be connected in a delta circuit where a line voltage prevails.

Example

Line voltage:	400 V
Rated motor current:	40.5 A
Current via soft starter in inside-delta circuit:	approx. 24 A
Selected soft starter in inside-delta circuit:	3RW44 22

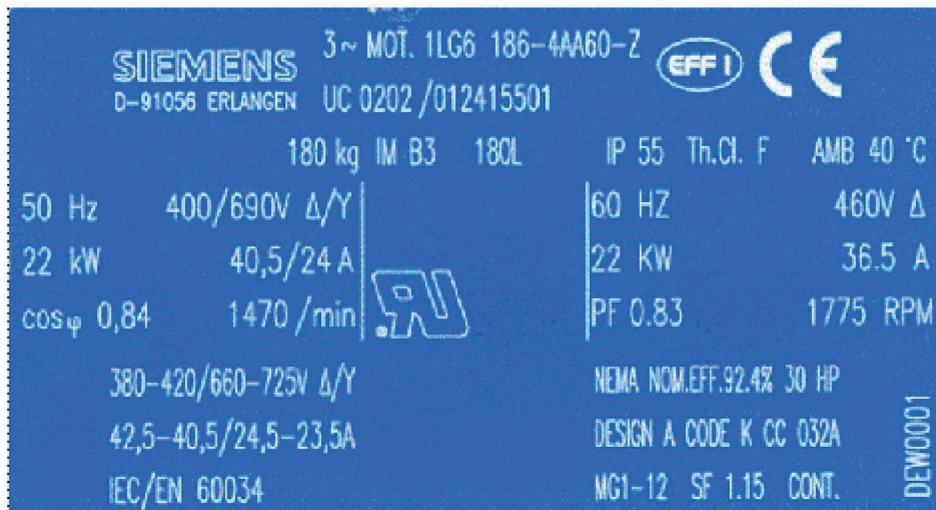

Figure 4-4 Nameplate of a 22 kW motor

The SIRIUS 3RW44 soft starter can be dimensioned to match the current flowing in the motor section (58 % of the conductor current) by connecting it to the delta winding of the motor. This requires at least 6 motor lines.

The 3RW44 soft starter automatically detects how it is connected, meaning that the connection type does not have to be explicitly set on the device. The detected connection type can be read on the starter in the "Status display/Type of connection" menu item. In this case, the display reads "Inside-delta circuit". If the circuitry is faulty or the motor is not connected, the display shows "Unknown".

NOTICE

The rated motor current given on the nameplate must always be set in the quick start menu or in the motor adjustment menu item. This setting is independent of the soft starter's type of connection.
Value to be set in the above example for a line voltage of 400 V, e.g. 40.5 A.

NOTICE

The DC braking and combined braking device functions are no longer available for inside-delta circuits.
To ensure proper functioning of the soft starter, the electrical connection of the main voltage (line and motor side) must be made according to the given circuit examples (see chapter Connection examples for main and control circuits (Page 229)).

4.2 Design of the feeder

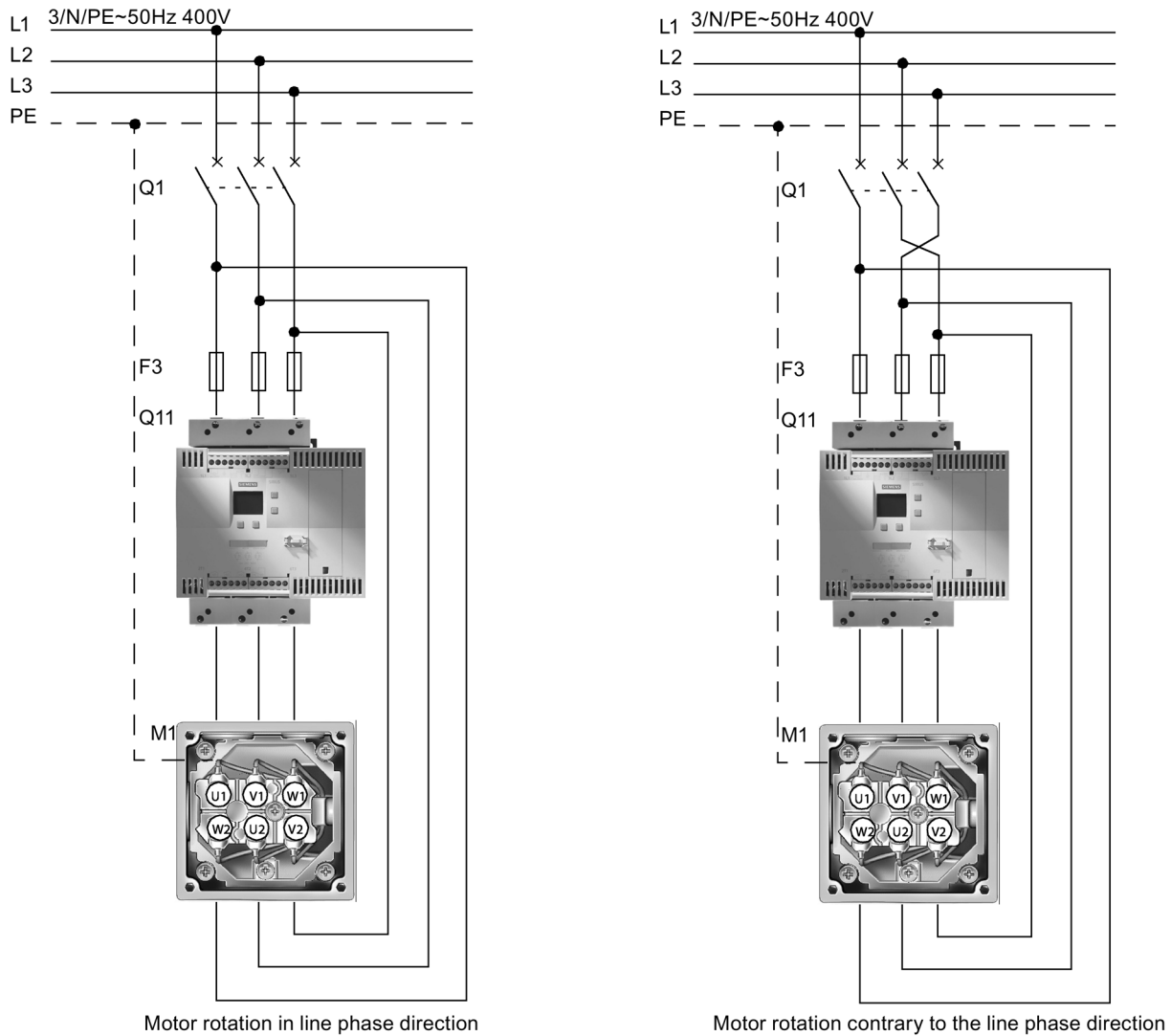

Figure 4-5 Block diagram of 3RW44 soft starters in inside-delta circuits

NOTICE

Error message due to delayed switching of the contactor

If a main or line contactor is connected between the soft starter and the motor or in the return line between the motor and the soft starter, steps must be taken to ensure that this contactor is connected within 100 ms of activation of the start command for the 3RW44.

If the contactor is not connected within 100 ms of activation of the start command for the 3RW44, the soft starter no longer recognizes the current circuit variant (standard circuit or inside-delta circuit). A "Missing load phase 1-3" error message is generated.

4.2.4 Soft starter with contactor disconnector (main contactor)

If electrical isolation is specified, you can install a motor contactor between the soft starter and the motor starter protector or you can use a fault output relay. (For contactor assignments, refer to chapter Technical data (Page 268).

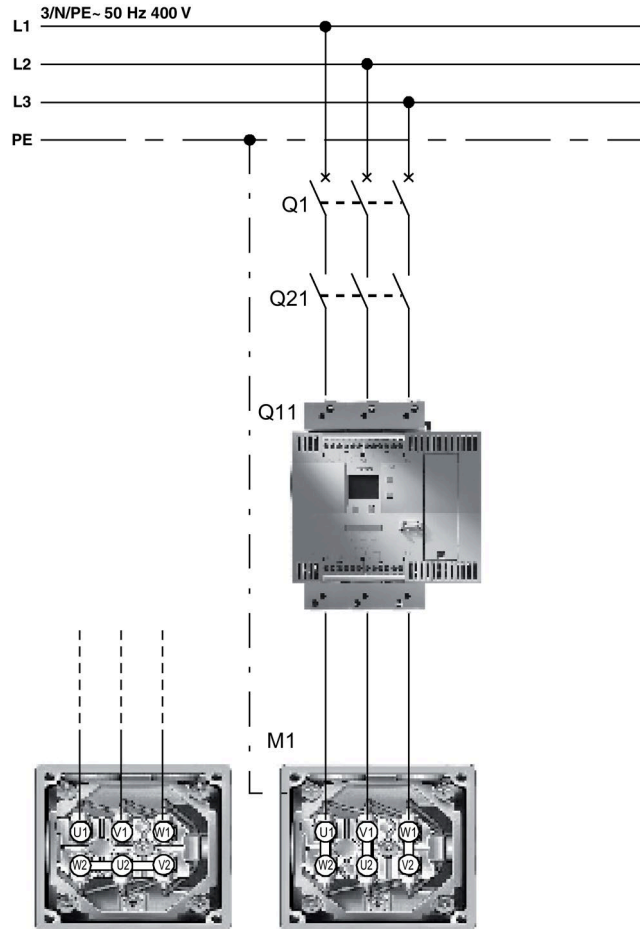

Figure 4-6 Block diagram of a feeder with an optional main contactor / contactor disconnector

NOTICE

Error message due to delayed switching of the contactor

If a main or line contactor is connected between the soft starter and the motor or in the return line between the motor and the soft starter, steps must be taken to ensure that this contactor is connected within 100 ms of activation of the start command for the 3RW44.

If the contactor is not connected within 100 ms of activation of the start command for the 3RW44, the soft starter no longer recognizes the current circuit variant (standard circuit or inside-delta circuit). A "Missing load phase 1-3" error message is generated.

NOTICE

In the case of 3RW44 product version *E08* (FWV 1.9.0) the simultaneous and/or premature switch-off of the main contactor and removal of the ON command at the soft starter may lead to direct-on-line starting behavior of the motor when restarting. Include a tripping delay of 1 s for the main contactor or control the main contactor via an output with parameterized "ON time" function as described in chapter 3RW44 in a standard circuit with line contactor and control via PLC (Page 231).

4.3 Protection of the soft starter against short-circuits (type of assignment 2)

The soft starter has internal protection to prevent overloading of the thyristors. This internal thyristor protection function is not sufficient in the event of a defect in the motor windings or a short-circuit in the motor's power supply cable, for example. Special semiconductor fuses, e.g. SITOR fuses from SIEMENS, must be used for this purpose.

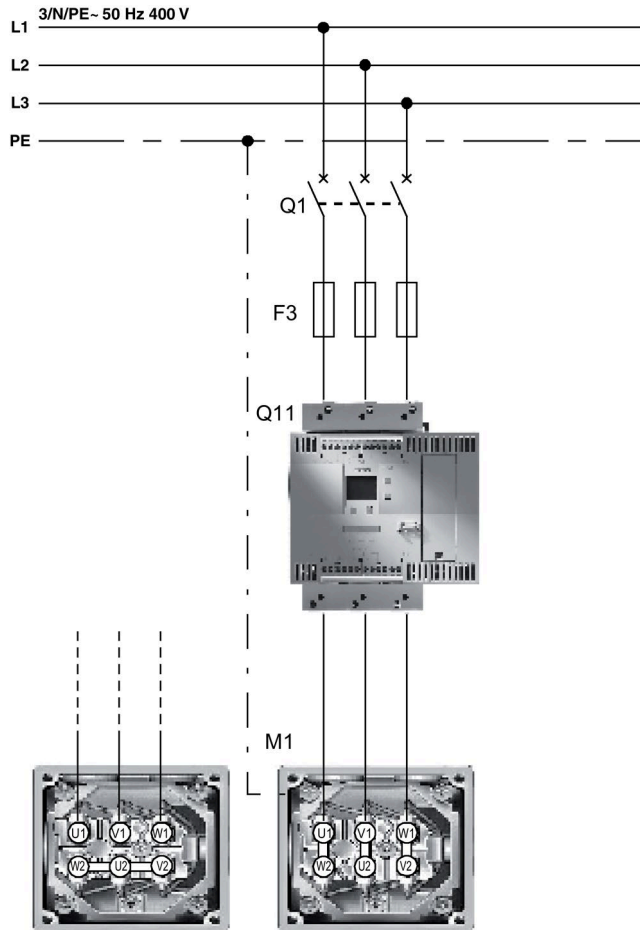

Figure 4-7 Block diagram of a feeder with semiconductor fuses

4.3 Protection of the soft starter against short-circuits (type of assignment 2)

Note

There are two possibilities of protecting against a short-circuit:

Protecting against short-circuits in accordance with type of coordination 1:

the device may be defective after a short-circuit and must be replaced. Chapter Feeder component layout (standard circuit) (Page 286) contains details of fuses/circuit breakers for short-circuit protection in accordance with type of coordination 1.

Protecting against short-circuits in accordance with type of coordination 2:

the device is not damaged by a short-circuit. Type of coordination 2 is recommended for high plant availability. The soft starter has internal protection to prevent overloading of the thyristors during normal operation. This internal thyristor protection function is not sufficient, however, in the event of a defect in the motor windings or a short-circuit in the motor's power supply cable, for example. Special semiconductor fuses, e.g. SITOR fuses from SIEMENS, must be used for this purpose.

NOTICE

Risk of property damage

Type of coordination 1 in accordance with IEC 60947-4-1: The device is defective following a short-circuit failure and therefore unsuitable for further use (personnel and equipment must not be put at risk). Type of coordination 2 in accordance with IEC 60947-4-1: The device is suitable for further use following a short-circuit failure (personnel and equipment must not be put at risk). The type of coordination only refers to soft starters in conjunction with the stipulated protective device (motor starter protector/fuse), not to additional components in the feeder.
--

4.4 Capacitors for improving the power factor

NOTICE
Capacitors must not be connected to the output terminals of the soft starter. If so, the soft starter will be damaged. Active filters, e.g. for power factor correction, must not be operated parallel to the motor control device.

If capacitors are to be used to correct the power factor, they must be connected on the device's line side. If a contactor disconnect or main contactor are used together with the electronic soft starter, the capacitors must be disconnected from the soft starter when the contactor is open.

4.5 Generator operation with three-phase asynchronous motor

The 3RW44 soft starters are suitable for generator operation.

Note

The direction of power flow is also irrelevant for the overload relay integrated in the 3RW44 soft starters. This means that motor protection is guaranteed in all cases, regardless of whether motor or generator operation is concerned.

4.6 Electrical connection

4.6.1 Control and auxiliary circuit connection

The SIRIUS 3RW44 soft starter is supplied with two different connection systems:

- Screw connections
- Spring-loaded connections

Two control voltage versions are available:

- 115 V AC
- 230 V AC

4.6.2 Main circuit connection

All soft starters have busbar connections for the main circuit connection.

Size 3RW44 2.

An additional box terminal for direct cable connection is supplied as standard with size 3RW44 2.

Sizes 3RW44 3. and 3RW44 4.

For size 3RW44 3. and 3RW44 4. devices, it is possible to retrofit box terminals as optional accessories (see chapter Accessories (Page 293)).

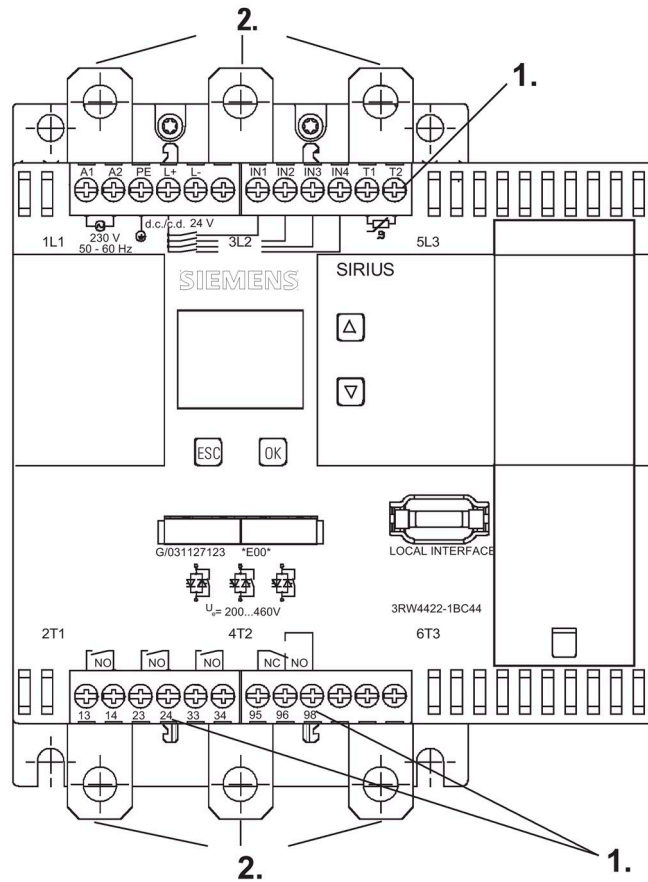

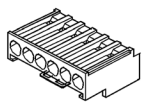
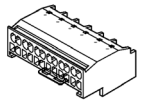



Figure 4-8 Connections

















1.	A1, A2, PE, L+, L-, IN1, IN2, IN3, IN4, T1, T2, 13, 14, 23, 24, 33, 34, 95, 96, 98: Control/auxiliary circuit
2.	L1/L2/L3 Main circuit infeed
3.	T1/T2/T3 Main circuit outgoing feeder load

Figure 3-8: Connections

NOTICE
It is not permitted to connect the 3-phase line infeed to terminals T1/T2/T3.

4.6.3 Conductor cross-sections

A1, A2, PE, L+, L-, IN1, IN2, IN3, IN4, T1, T2, 13, 14, 23, 24, 33, 34, 95, 96, 98		
	3RW44..-1.... 3RW44..-6....	3RW44..-2.... 3RW44..-3....
		
 Ø 5...6 mm/PZ2	0.8...1.2 Nm 7 to 10.3 lb.in	-
	1 x 0.5...4.0 mm ² 2 x 0.5...2.5 mm ²	2 x 0.25...1.5 mm ²
	2 x 0.5...1.5 mm ² 1 x 0.5...2.5 mm ²	2 x 0.25...1.5 mm ²
	-	2 x 0.25...1.5 mm ²
AWG	2 x 20...14	2 x 24...16

L1, L2, L3; T1, T2, T3							
3RW44 2.-...		3RW44 3.-...		3RW44 4.-...		3RW44 5.-... / 3RW44 6.-...	
	4...6 Nm 36...53 lb.in	M8x25	10...14 Nm 89...124 lb.in	M10x30	14...24 Nm 124...210 lb.in	M12x40	20...35 Nm 177...310 lb.in
	2 x 10...70 mm ² 2 x AWG 7...1/0		2 x 25...120 mm ² 2 x AWG 4...250 kcmil		2 x 70...240 mm ² 2 x AWG 2/0...500 kcmil		2 x 70...240 mm ² 2 x AWG 2/0...500 kcmil
	2 x 10...50 mm ² 2 x AWG 7...1/0		2 x 16...95 mm ² 2 x AWG 6...3/0		2 x 50...240 mm ² 2 x AWG 2/0...500 kcmil		2 x 50...240 mm ² 2 x AWG 2/0...500 kcmil
	min. 2 x 3 x 0.8 max. 10 x 15.5 0.8		b ≤ 17 mm		b ≤ 25 mm		b ≤ 60 mm
	2 x 2.5...16 mm ²	--	--	--	--	--	--
	2 x 2.5...35 mm ² 1 x 2.5...50 mm ²	--	--	--	--	--	--
	2 x 10...50 mm ² 1 x 10...70 mm ² 2 x AWG 10...1/0 1 x AWG 10...2/0	--	--	--	--	--	--

Display, controls and device interfaces

5.1 Display and controls

Graphic display

There is a graphic display on the front of the device from which the functions and states of the soft starter can be read in plain text and with the help of symbols when control voltage is applied.

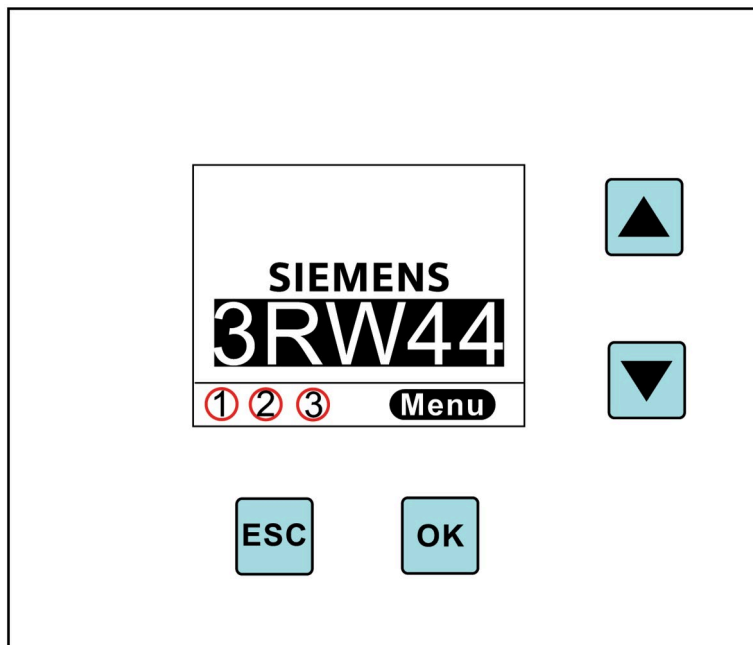

① Shows the operator panel that currently has control priority and is thus issuing the control commands for the motor.		② Indicates the user level setting		③ Indicates the current motor status	
	Display with keys		Customer read only		No motor
	Serial interface		Customer write		Startup
	Control inputs				Motor is running
	PLC via PROFIBUS/ PROFINET				Run down
	PC via bus				Motor ready to start
	No control device				

Operator controls

There are four keys for operating and adjusting the soft starter:



The current function, depending on the menu item, is shown as text on the display above this key (e.g. select menu, change value or save settings).



The current function, depending on the menu item, is shown as text on the display above this key (e.g. select menu, change value or save settings).



The ESC key is used to quit the current menu item and to jump back to the higher-level menu item.

5.2 Device interfaces

5.2.1 Local device interface

A local device interface on the front side of the starter is provided as standard. This interface can be used to connect either an optional external operating and display module, or the "Soft Starter ES" operating, monitoring and parameterizing software (see chapter Accessories (Page 293)) using a PC and a connecting cable.

5.2.2 PROFIBUS/PROFINET interface (optional)

The SIRIUS 3RW44 soft starter can be equipped with an optional PROFIBUS module (only available for products delivered after 04/2006) or with an optional PROFINET module (only available for products delivered after 06/2013). The soft starter can be connected to PROFIBUS/PROFINET, operated and parameterized via the interface. The "Soft Starter ES" operating, monitoring and parameterizing software (see chapter Accessories (Page 293)) can also be connected to this interface using a PC and a connecting cable.

Simultaneous operation of a 3RW44 with a PROFIBUS/PROFINET interface is not possible in networks where one line conductor is grounded.

5.3 External display and control module (optional)

When de-energized, the external display and control module can be connected to the local device interface via a special connecting cable.

After switching on, the SIRIUS 3RW44 soft starter automatically recognizes that the external display and control module has been connected. The 3RW44 display will be inverted and the display and control module's display will be shown normally.

The control keys of the 3RW44 will be inactive, meaning that normal handling is only possible via the external display and control module.

Refer to chapter General technical data (Page 257) for ordering data.

Commissioning

6.1 Menu structure, navigation, changing parameters

The 3RW44 functions (parameterization, diagnostics and motor control) can be executed using the four control keys. The menu has various sub-levels, which must be handled in different ways but are self-explanatory.

6.1.1 Menu structure and navigation

Menu structure

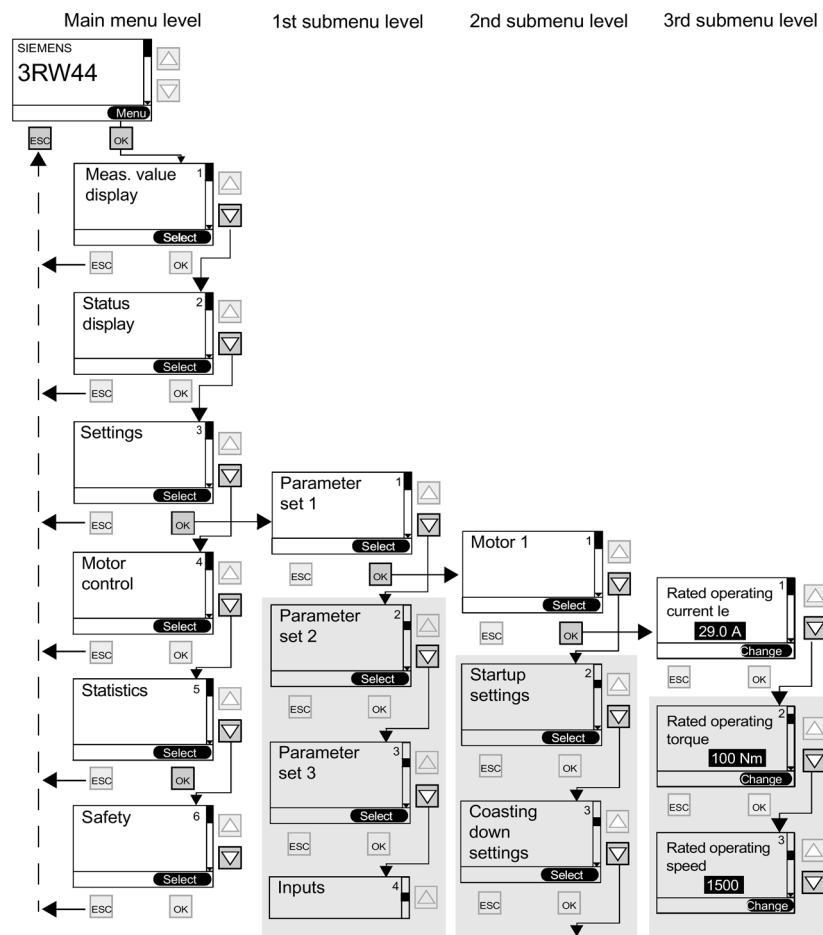

6.1.2 Changing parameters: for example motor data

Changing values, e.g. adjusting motor data

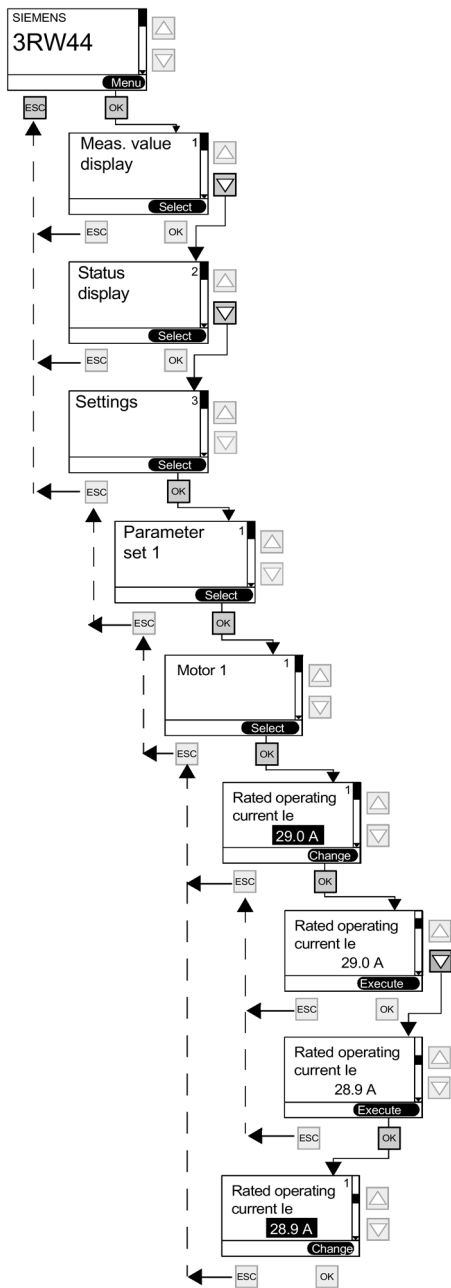

6.2 Switching on for the first time

WARNING

Before switching the device on for the first time, verify that the main/control side is wired properly. Make sure that the line and control voltages comply with the device-specific requirements (refer to chapter Technical data (Page 268)).

6.2.1 Recommended procedure for commissioning 3RW44

Suggested setting	Startup parameters				Stopping parameters		
	Startup mode: voltage ramp and current limiting (U+ current limiting)				Coasting method	Parameters	
	Starting voltage %	Starting time s	Current limiting value	Breakaway pulse		Coast-down time s	Stopping torque %
Application							
Conveyor belts	70	10	Deactivated	Deactivated (0 ms)	Torque control	10	10
Roller conveyors	60	10	Deactivated	Deactivated (0 ms)	Torque control	10	10
Compressor	50	10	4 x I _e	Deactivated (0 ms)	Coasting down	X	X
Small fans	30	10	4 x I _e	Deactivated (0 ms)	Coasting down	X	X
Pump	30	10	4 x I _e	Deactivated (0 ms)	Pump stop	10	10
Hydraulic pumps	30	10	4 x I _e	Deactivated (0 ms)	Coasting down	X	X
Stirrers	30	30	4 x I _e	Deactivated (0 ms)	Coasting down	X	X
Centrifuges	30	30	4 x I _e	Deactivated (0 ms)	Coasting down	X	X
Milling machines	30	30	4 x I _e	Deactivated (0 ms)	Coasting down	X	X
Large fans	30	60	4 x I _e	Deactivated (0 ms)	Coasting down	X	X
Mills	50	60	4 x I _e	80 %/300 ms	Coasting down	X	X
Crushers	50	60	4 x I _e	80 %/300 ms	Coasting down	X	X
Circular saws/ band saws	30	60	4 x I _e	Deactivated (0 ms)	Coasting down	X	X

Note

This table provides example settings. They are intended for information purposes only and are not binding. Set values depend on the application in question and must be optimized during commissioning.

6.2.2 Quick start menu, when switching on for the first time

Quick commissioning of the soft starter

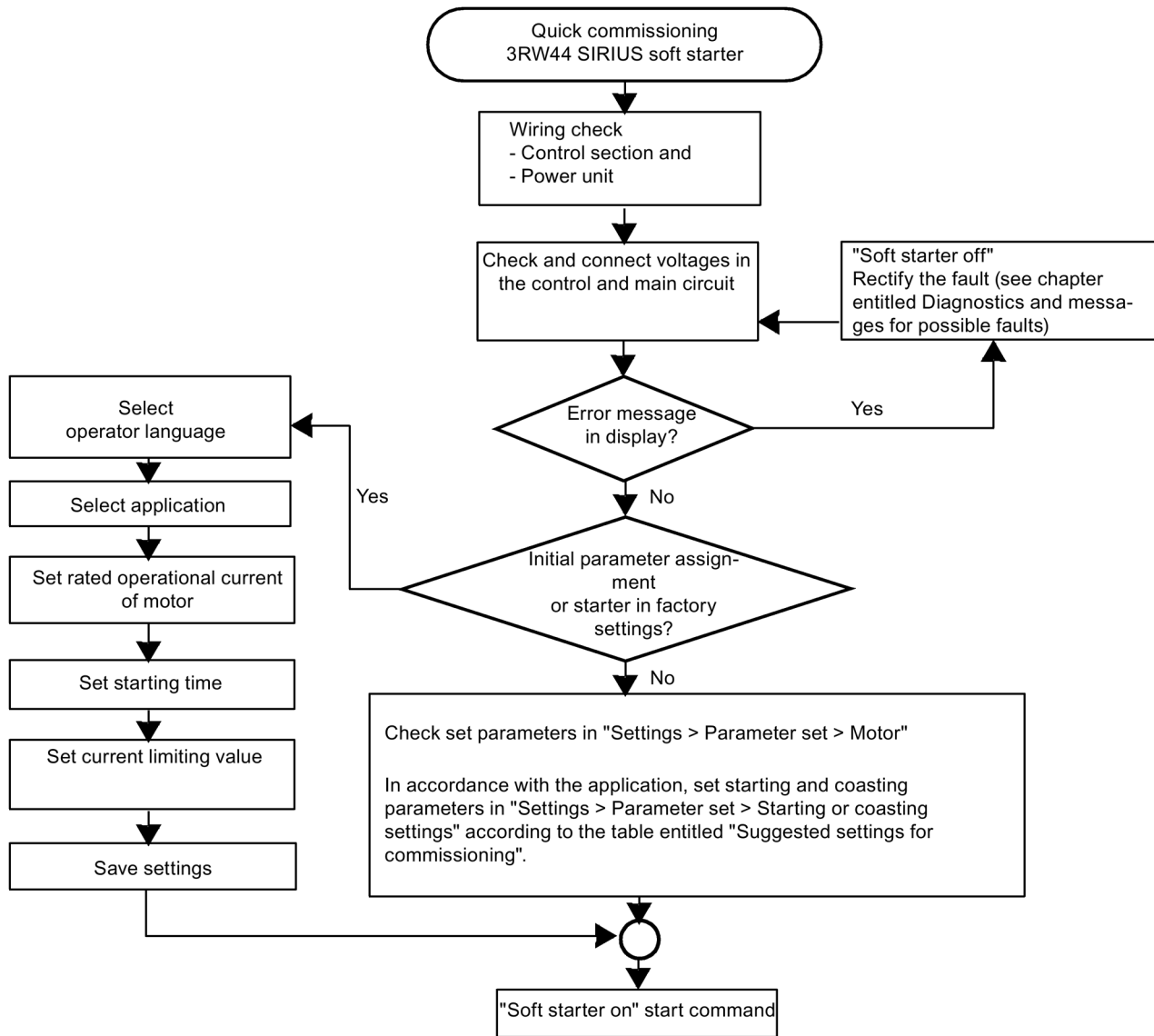

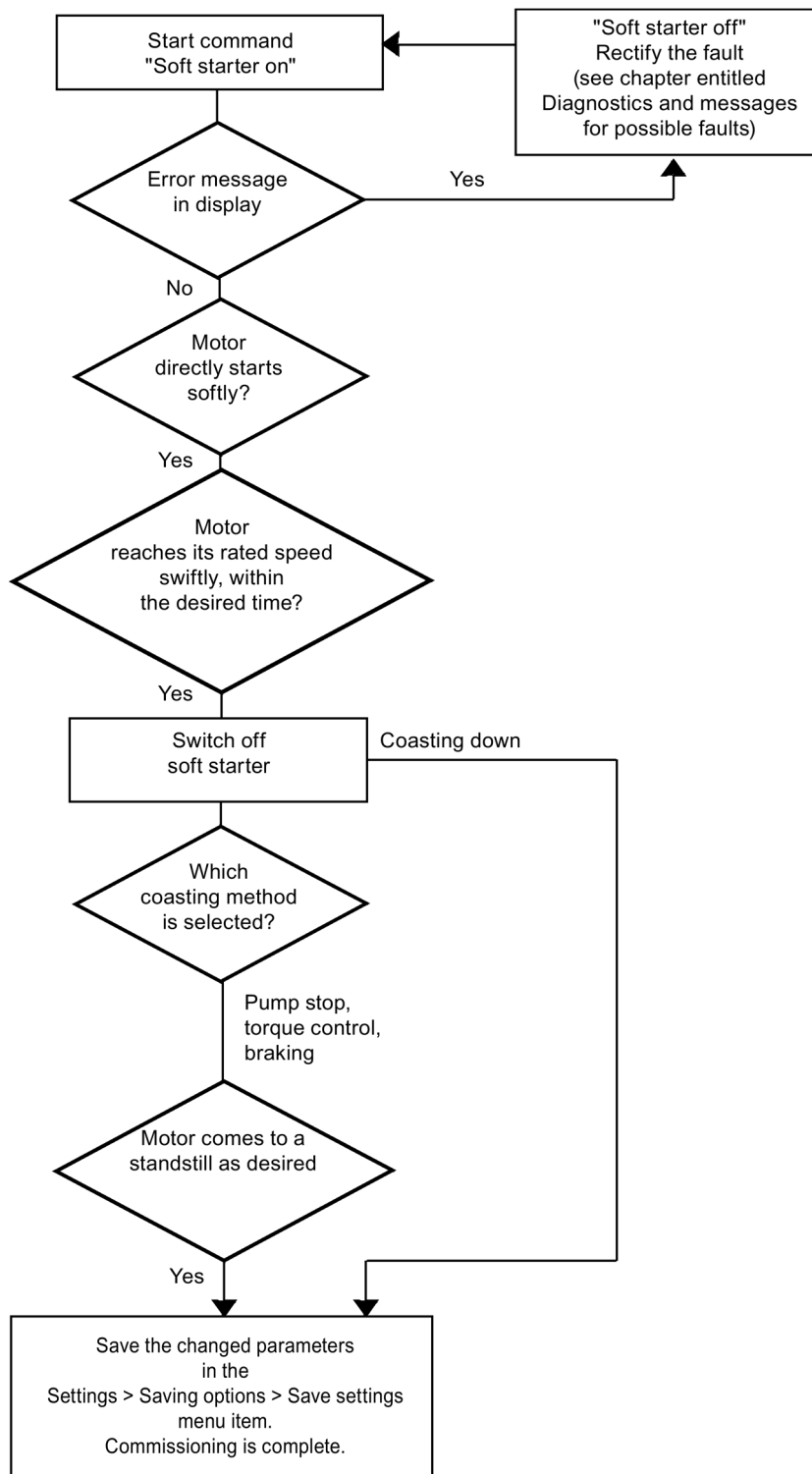

6.2.3 Problems that can occur

The motor does not directly start smoothly

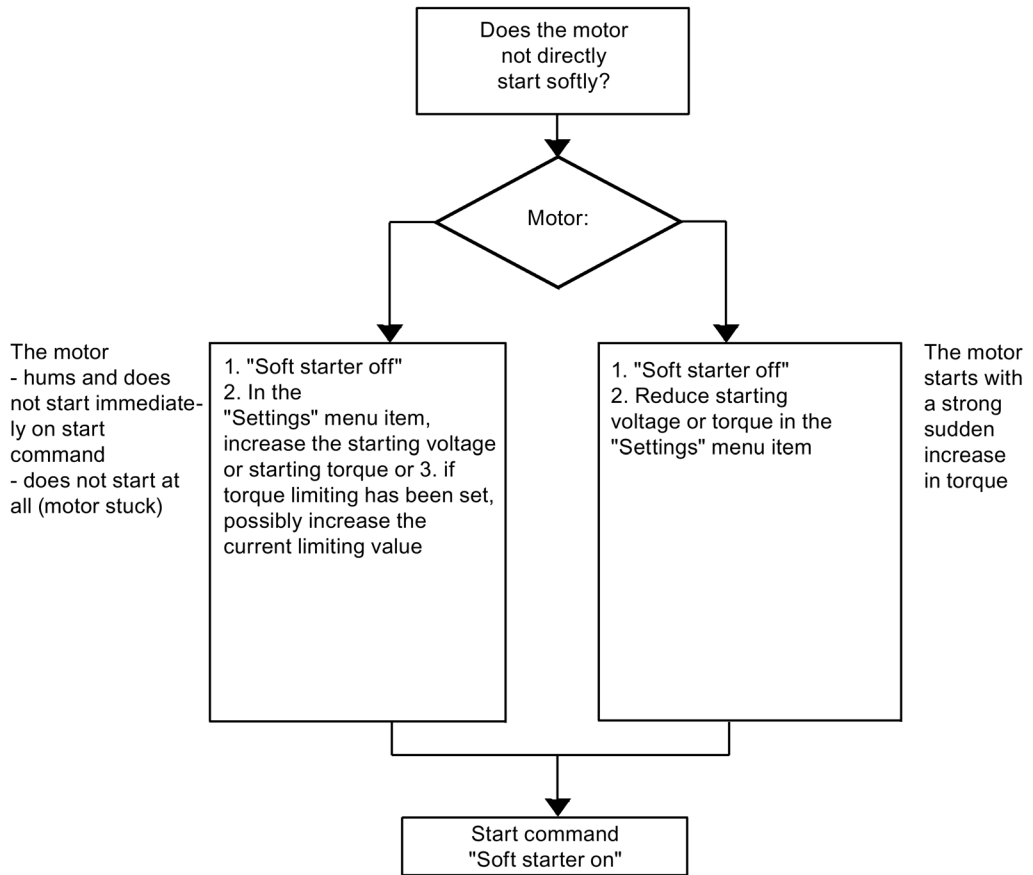

The motor does not swiftly reach its nominal rotational speed in the desired time

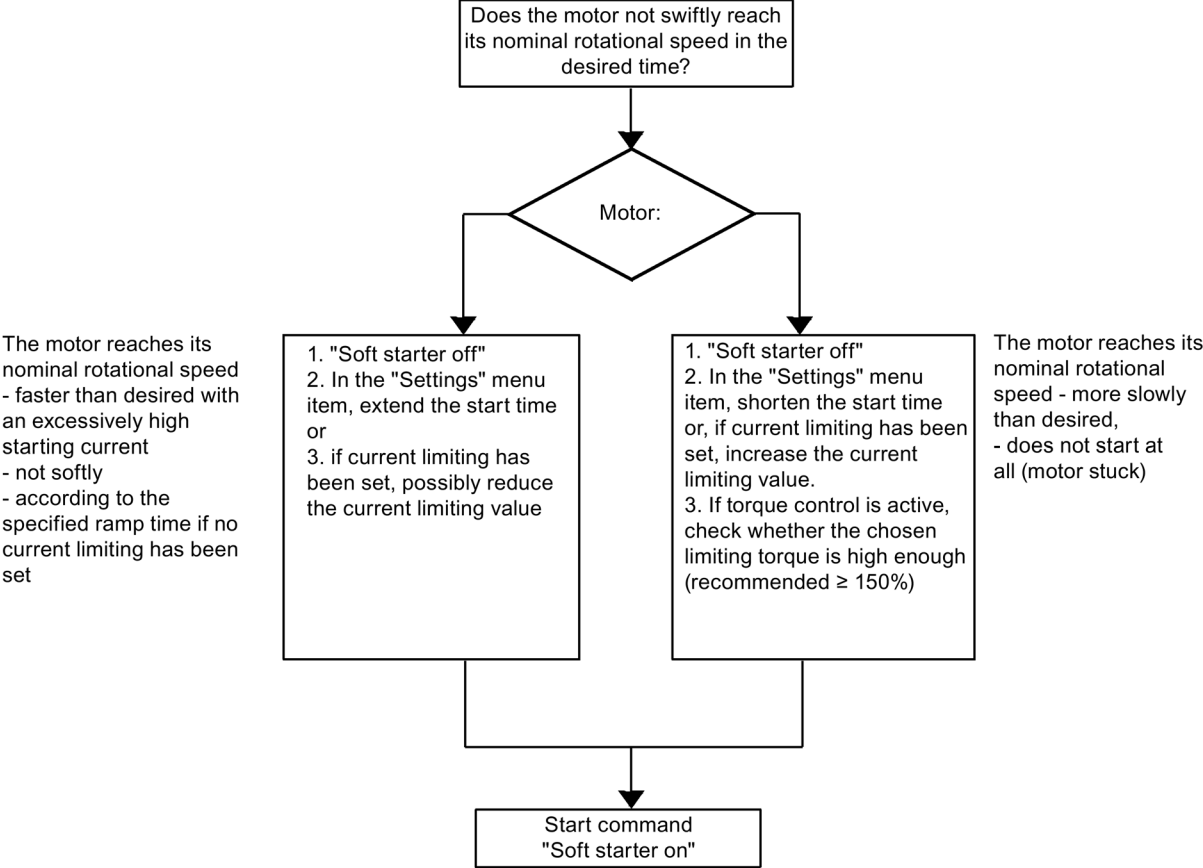

The motor does not reach zero speed as desired

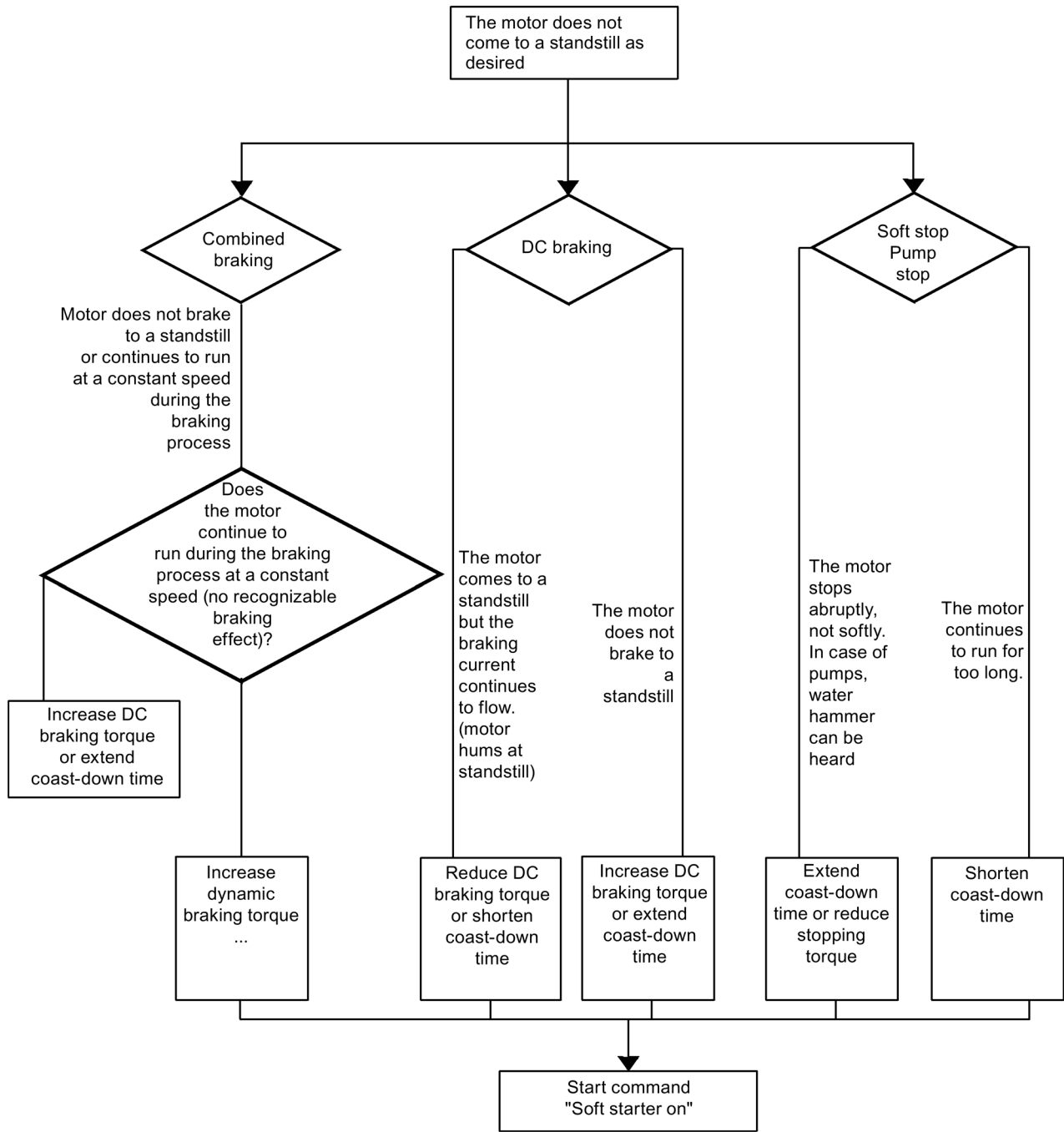

6.2.4 Quick Start menu

Note

After applying the control supply voltage for the first time, you will automatically be in the quick start menu, which you must go through once to commission the soft starter for the first time.

In the quick start menu, you need to enter the information needed to preset the most important parameters of the soft starter for your application. Starting parameters for typical types of applications are stored in the device parameters.

To achieve optimum motor starting, these parameters may need to be optimized on the basis of the connected load using the "Settings" menu item, as described in chapter Specifying the startup mode (Page 68).

If your particular load is not listed, select any load and optimize the defined parameters, if necessary, using the "Settings" menu item as described in chapter Specifying the startup mode (Page 68). The values of the basic factory settings of the parameters, and the predefined assignment of the control inputs and outputs, are listed in chapter Technical data (Page 268).

Note

If you confirm the last item "Save settings - execute?" by entering "Yes" in the quick start menu, you can only return to this menu by resetting the device to its basic factory settings (refer to "Restoring the factory settings" in chapter Saving options (Page 107)). This overwrites all settings made up to that point.

Quick Start menu

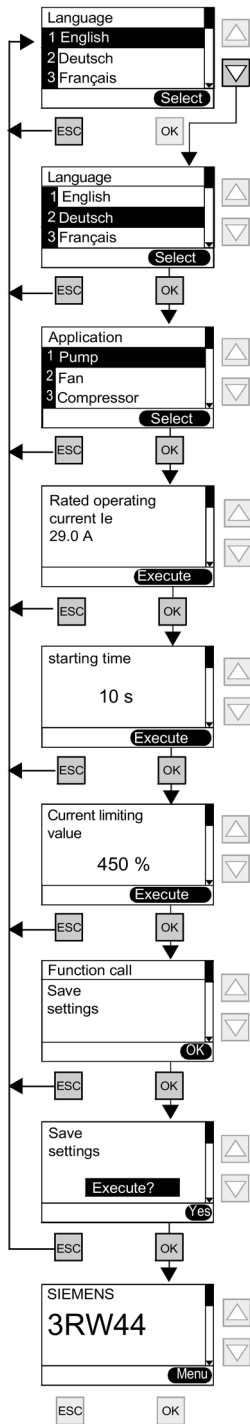

6.3 User-specific commissioning

If values are required that differ from the defined parameters in the Quick Start menu or in the factory settings of the 3RW44, please proceed as follows:

Under the "Settings" menu item, select (refer to chapter Settings main menu item (Page 64)).

1. Selecting the parameter set
2. Set motor data
3. Set startup mode and parameters
4. Set coasting method and parameters
5. Set inputs and outputs
6. Check motor protection settings
7. Saving settings

NOTICE

The setting is buffered in a Flash EPROM memory as soon as you change a setting in the menu and execute it using the "OK" button. It is then active in the soft starter as from this moment onwards. When the control supply voltage is switched off, this value will be canceled and the previous value restored. To permanently save the settings made in the soft starter, you must save the data as described in chapter Settings main menu item (Page 64) and chapter Saving options (Page 107).

6.3.1 Settings main menu item

Settings main menu item

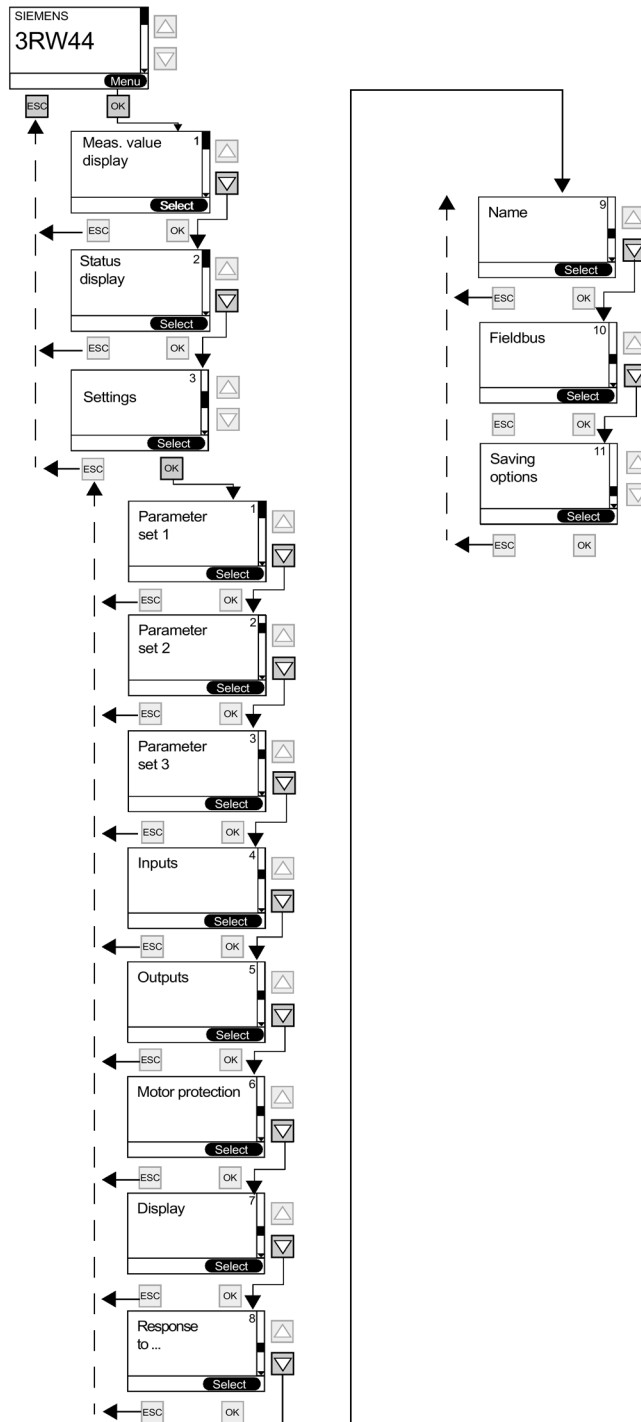

6.4 Making settings in the selected parameter set

6.4.1 Selecting the parameter set

Selecting the parameter set

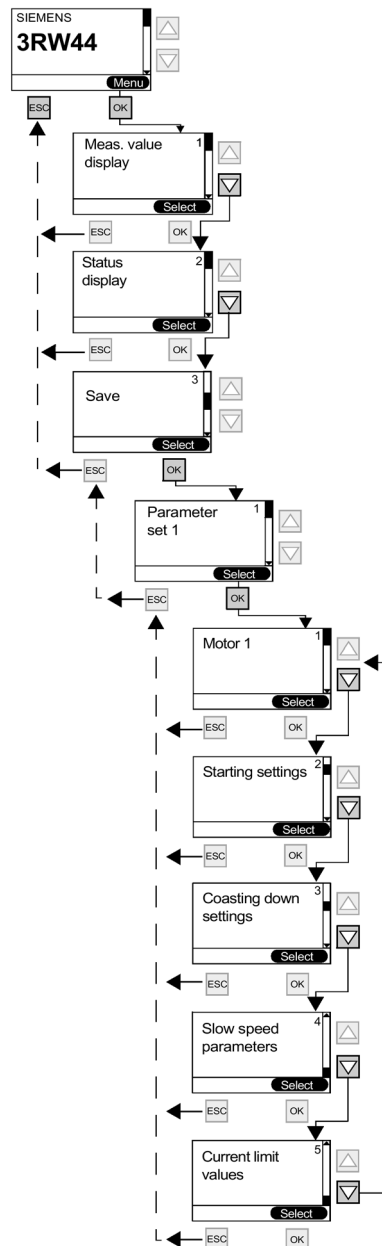

6.4.2 Entering the motor data

Entering the motor data and nameplate

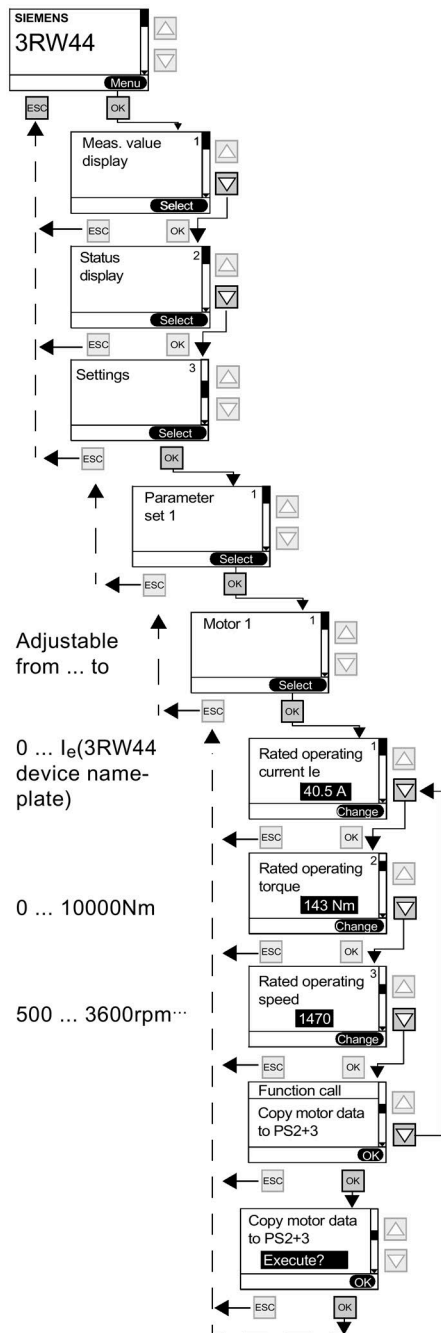

Adjustable from ... to

0 ... I_e(3RW44 device name-plate)

0 ... 10000Nm

500 ... 3600rpm...

Rated operational current I_e

Note

Always set the rated operating current of the motor stated on the motor nameplate based on the prevailing line voltage. This setting is independent of the type of connection of the soft starter (soft starter in standard or inside-delta circuit). Value to be set in the above example for a line voltage of 400 V, e.g. 40.5 A.

The motor current of the connected drive should be set to ensure proper functioning of the soft starter during starting and stopping, as well as with regard to motor protection.

Rated torque

If the motor's rated torque is not indicated on the nameplate, it can be calculated using the following formula:

$$M = 9.55 \times P \times \frac{1000}{n}$$

Example

$$9.55 \times 22 \text{ kW} \times \frac{1000}{1470 \text{ min}^{-1}} = 143 \text{ Nm}$$

If no value is specified, the value of the basic factory setting is active (0 Nm).

When the start command is given and the motor is connected, the soft starter automatically calculates the required value once.

Note

If a motor with rated data (current, speed, torque) that differs from the values already entered is connected to the soft starter (e.g. for testing purposes), this rated data must be adapted to the new motor. If 0 Nm is entered as the rated torque, the value is automatically calculated once by the soft starter.

6.4.3 Specifying the startup mode

Specifying the startup mode

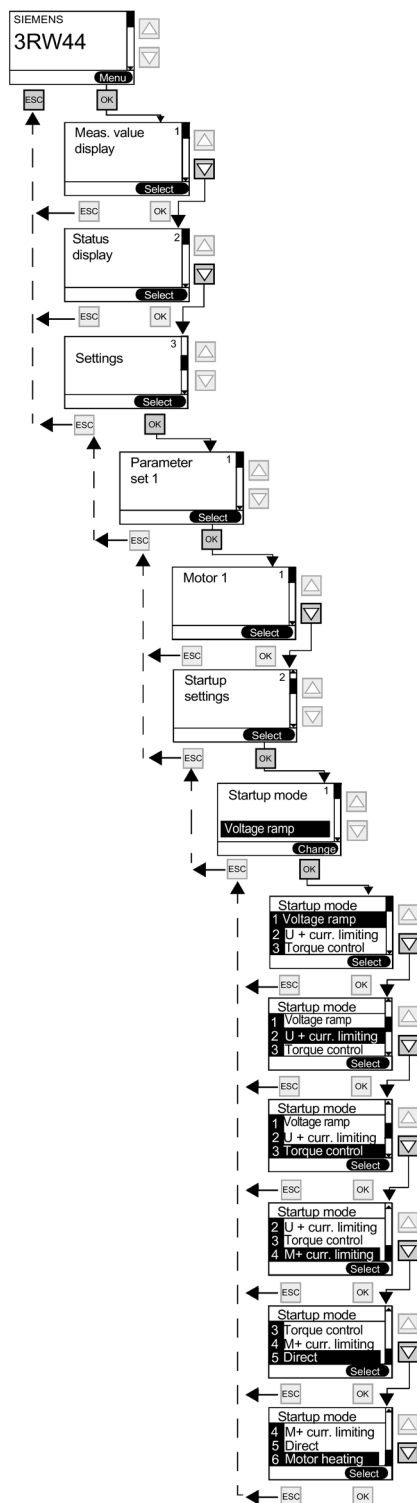

"Voltage ramp" startup mode

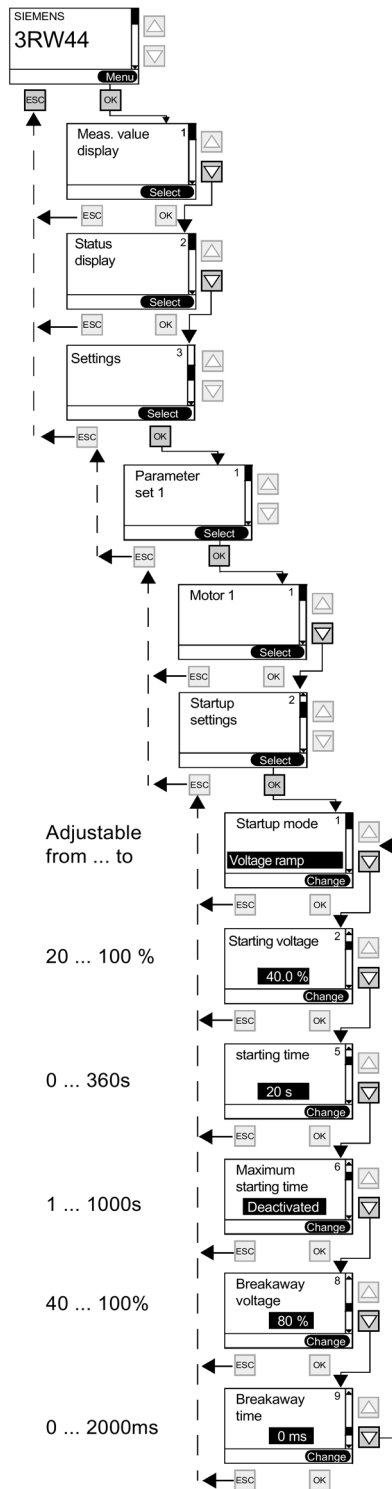

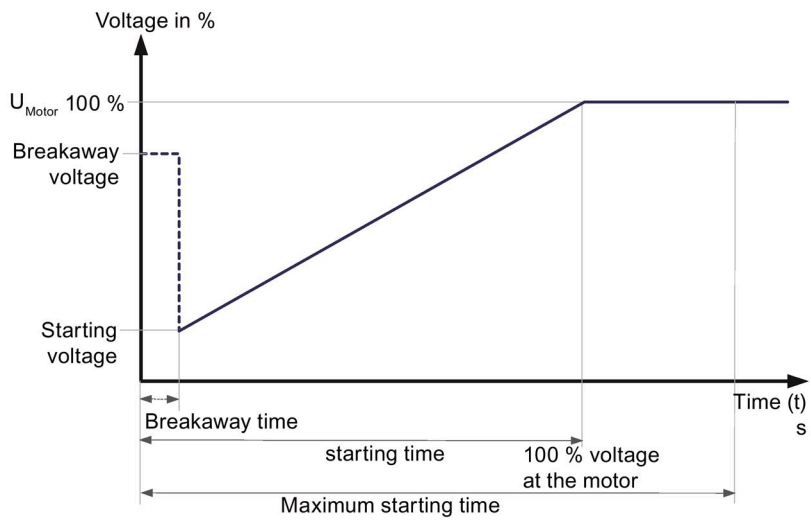

"Voltage ramp with current limiting" startup mode

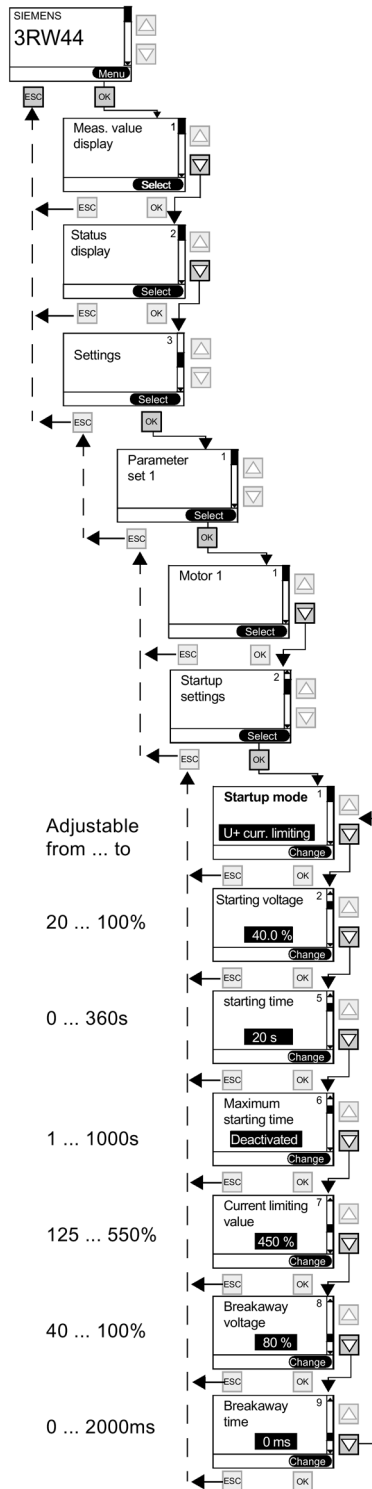

6.4 Making settings in the selected parameter set

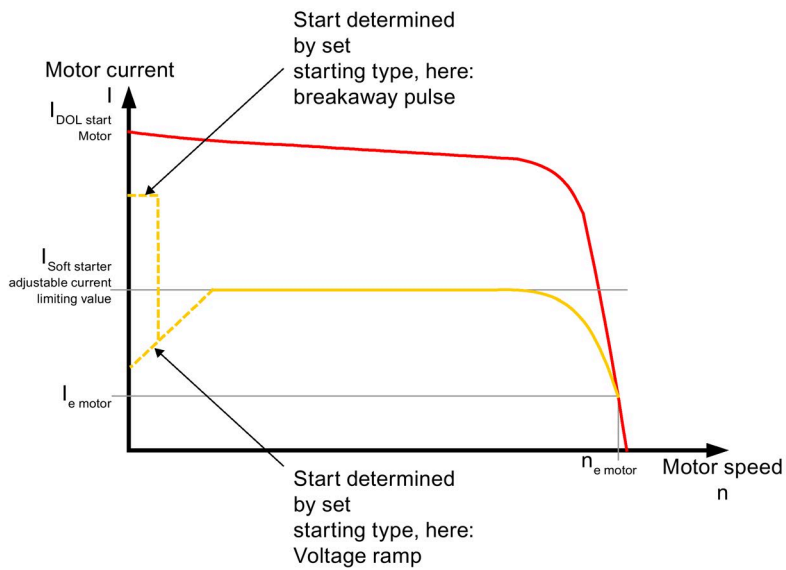
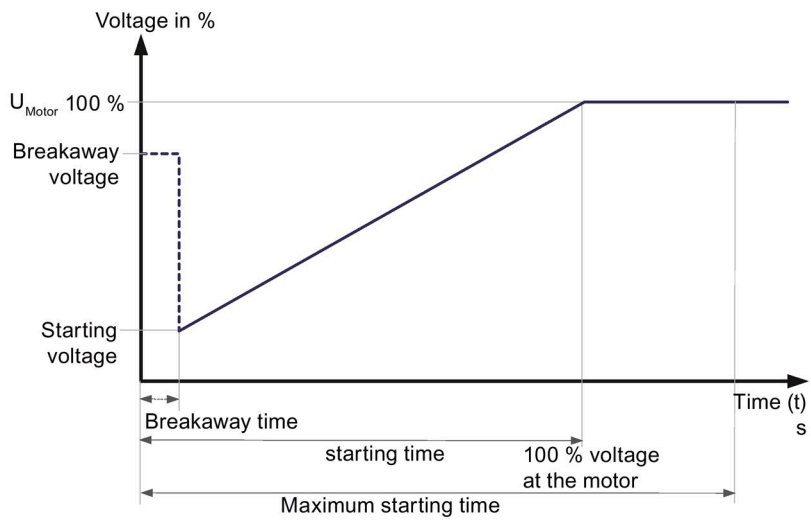

"Torque control" startup mode

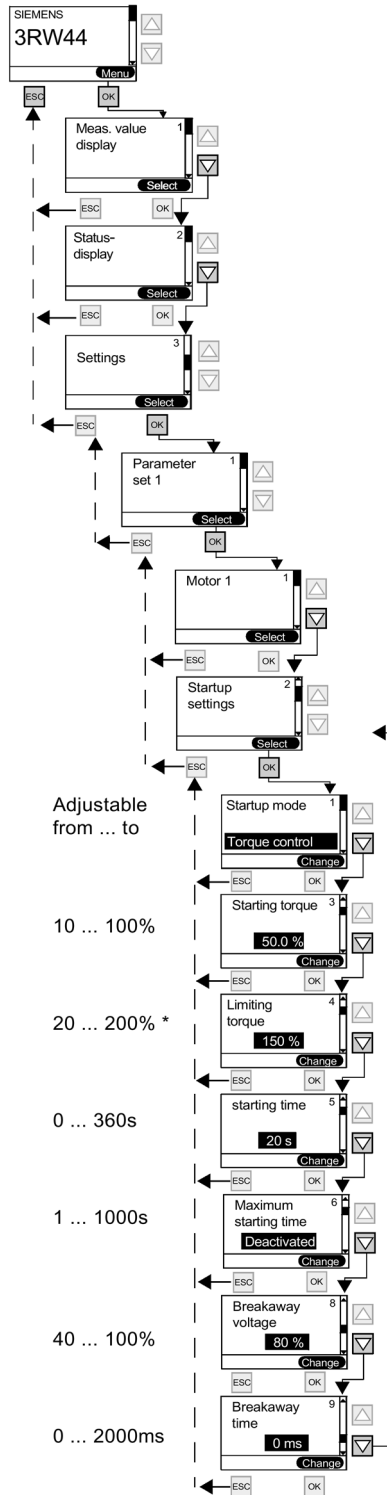

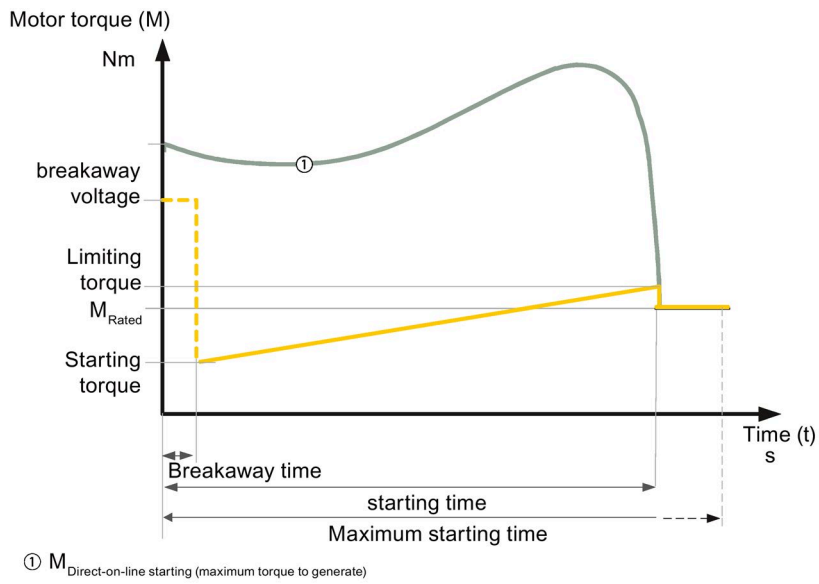

Limiting torque

NOTICE
* The parameter value should be set to approx. 150 % to start the motor. It should be high enough to ensure that the motor does not become stuck during run-up. This ensures that enough acceleration torque is generated throughout the motor run-up phase.

"Torque control with current limiting" startup mode

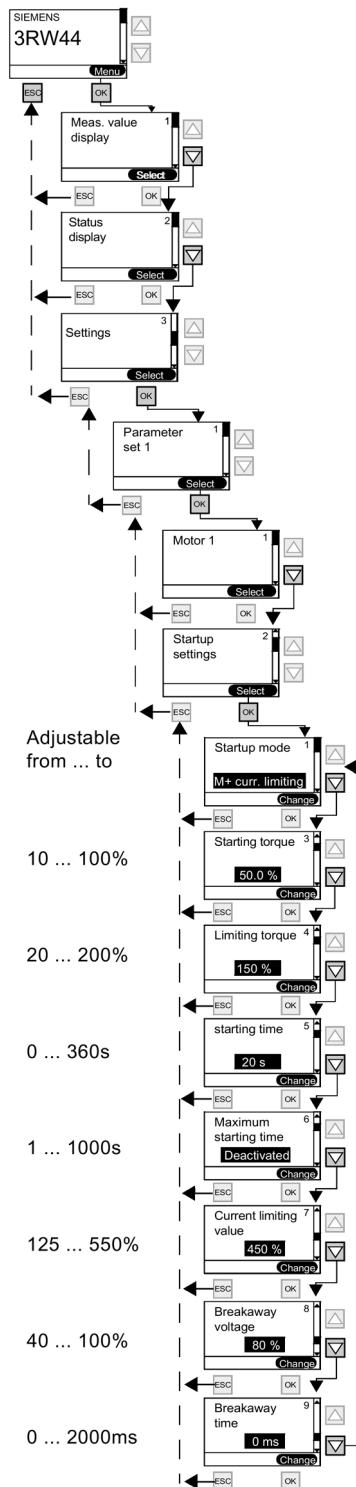

6.4 Making settings in the selected parameter set

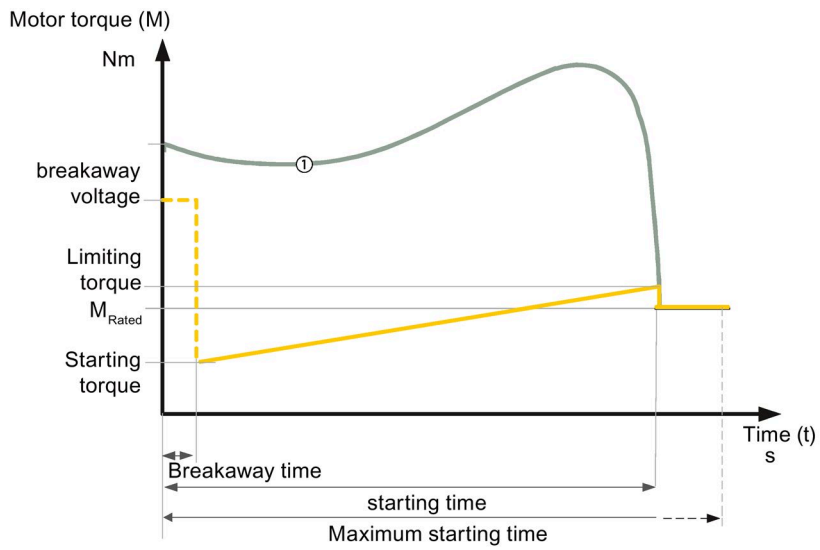

① M Direct-on-line starting (maximum torque to generate)

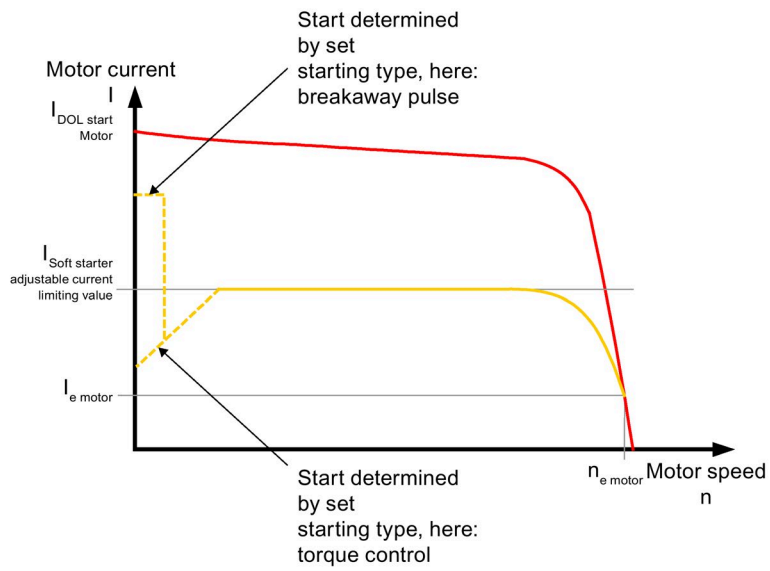

"Direct on-line starting" mode

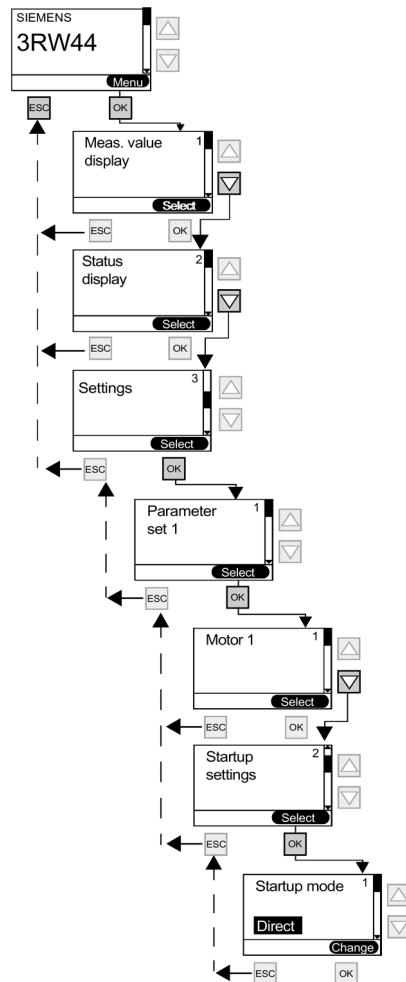

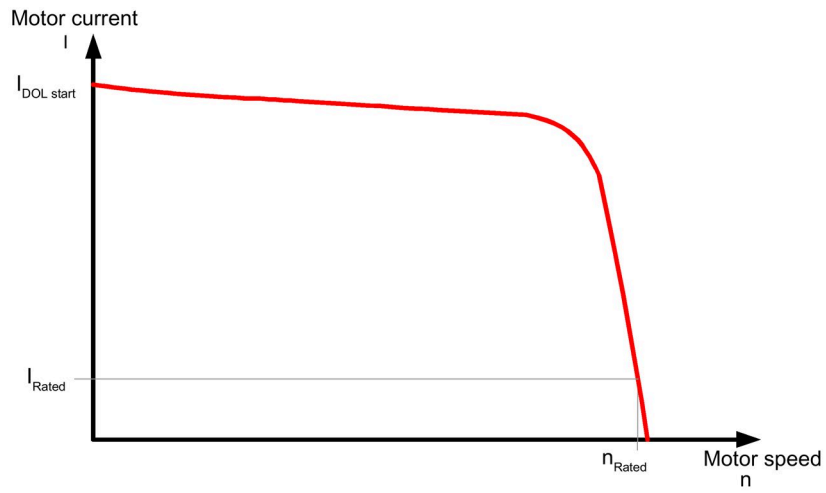
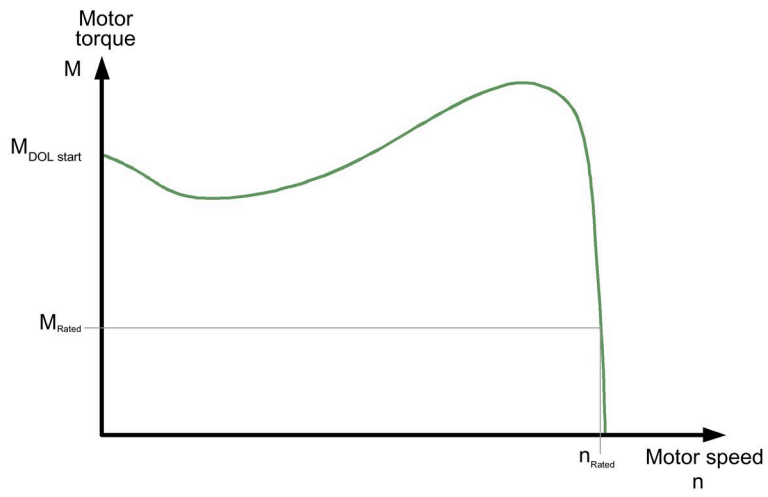

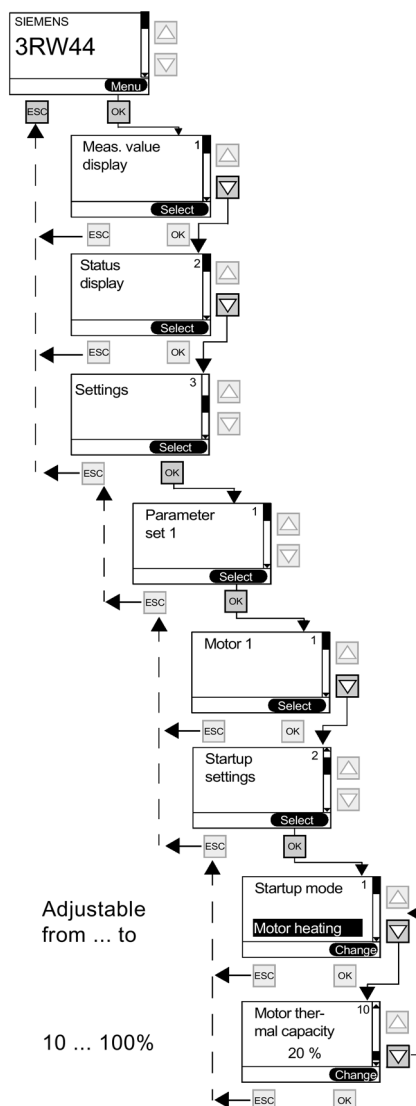
"Motor heating" startup mode**Motor thermal capacity****⚠ CAUTION**

May lead to damage to property.

The "Motor heating" startup mode is not a continuous operating mode. The motor must be equipped with a temperature sensor (Thermoclick/PTC) to ensure motor protection. The motor model with integrated electronic motor overload protection is not suitable for this kind of operation.

6.4.4 Specifying the coasting method

Specifying the coasting method

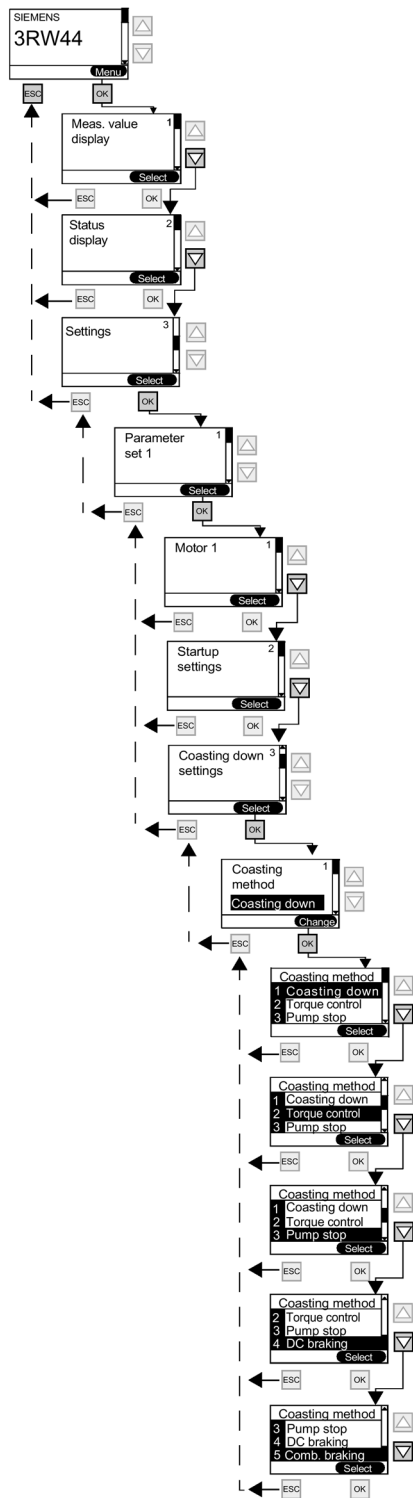

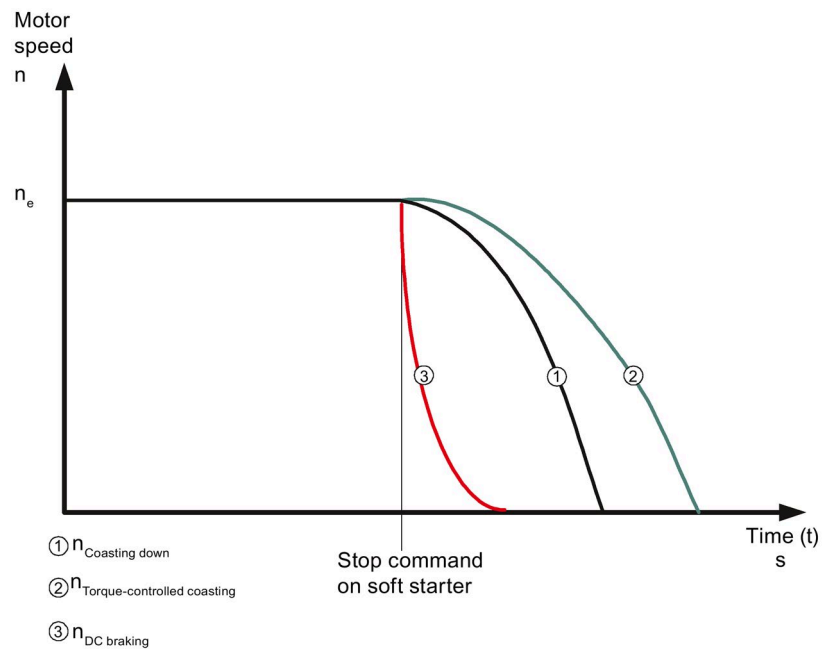

"Coasting down" coasting method

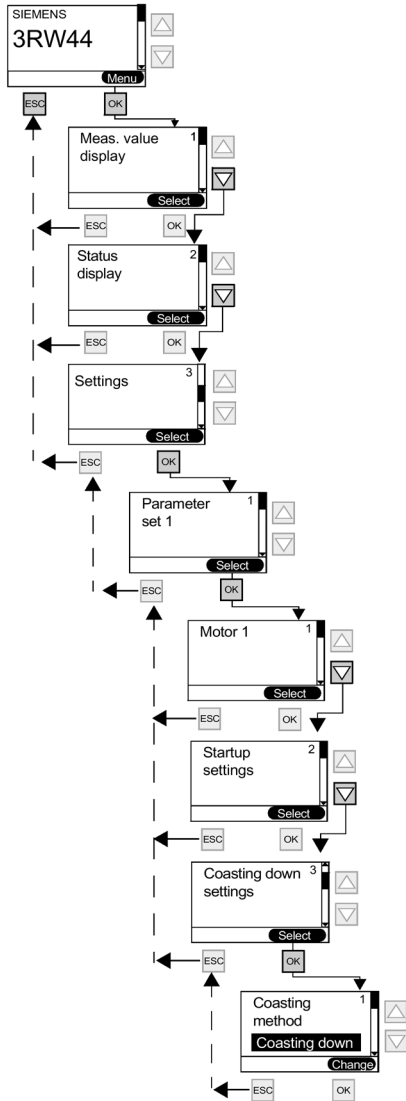

"Torque control" coasting method (soft stop)

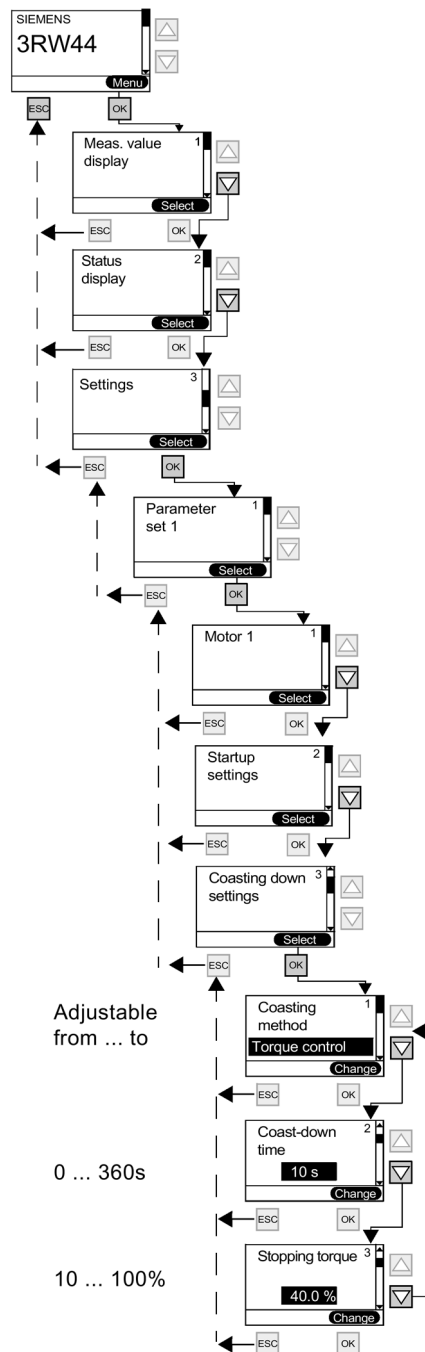

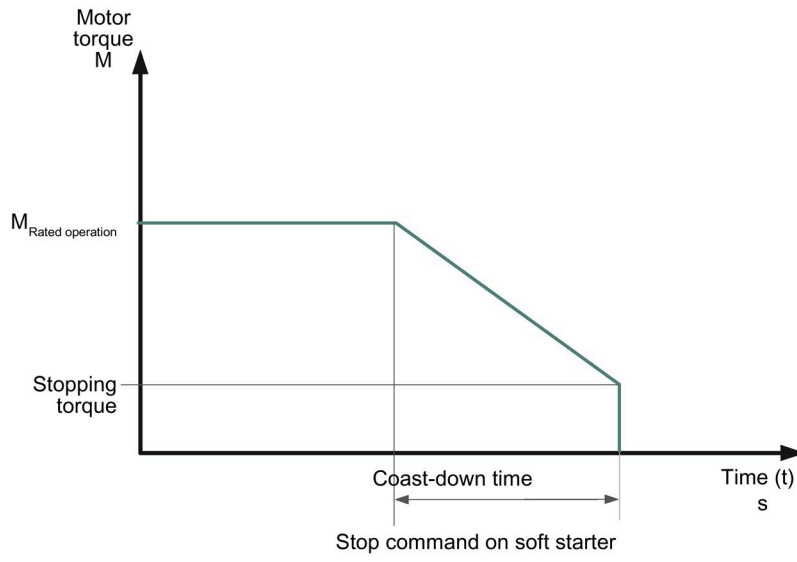

"Pump stop" coasting method

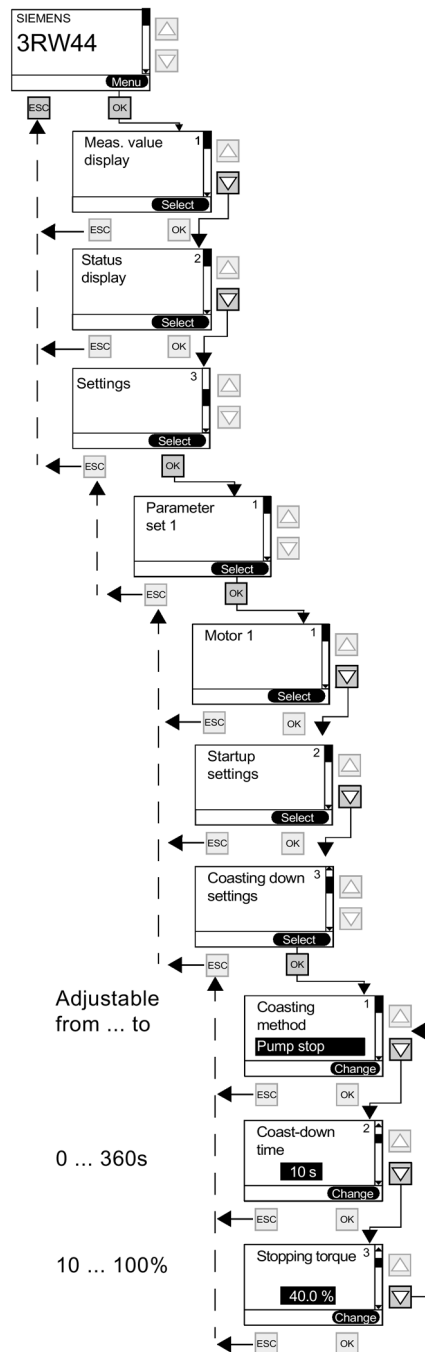

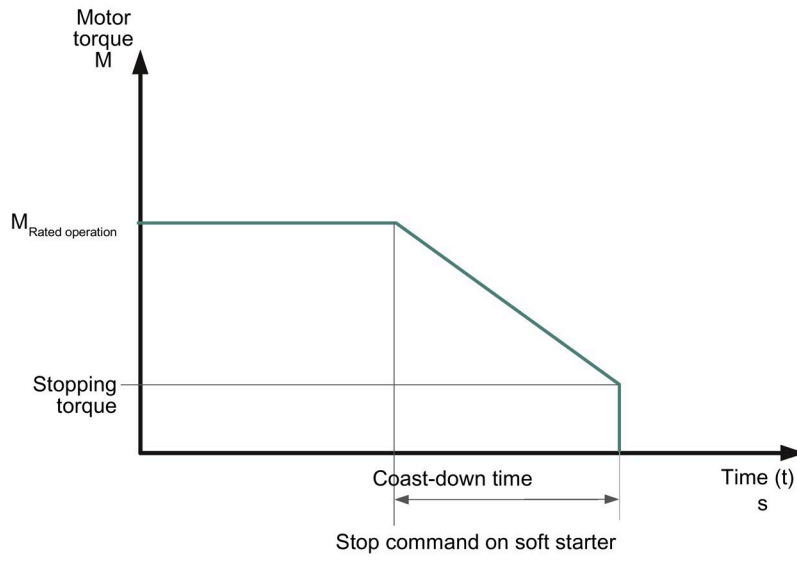

"DC braking" coasting method

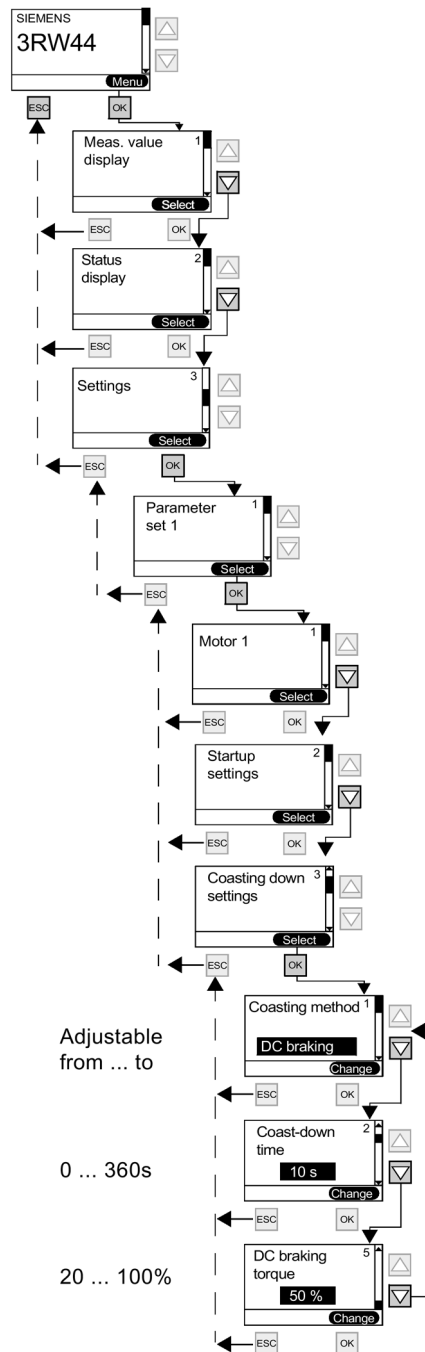

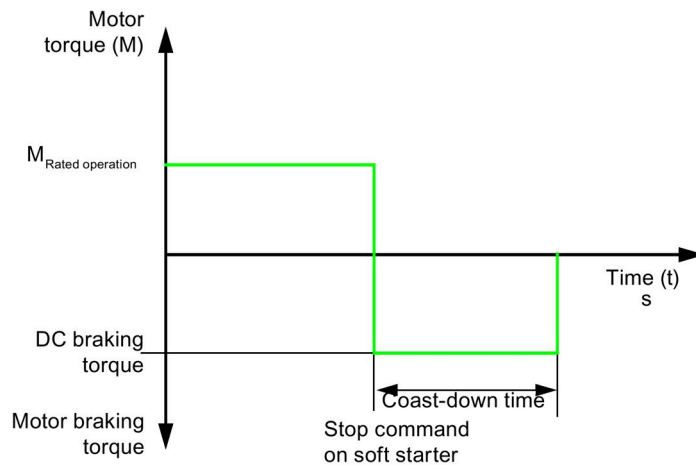

NOTICE

The DC braking/combined braking stopping function is not possible in inside-delta circuits.

Note

If the "DC braking" function is selected, the "DC braking contactor" function must be assigned to one output of the soft starter. This output must be used to control an external braking contactor.

"Combined braking" coasting method

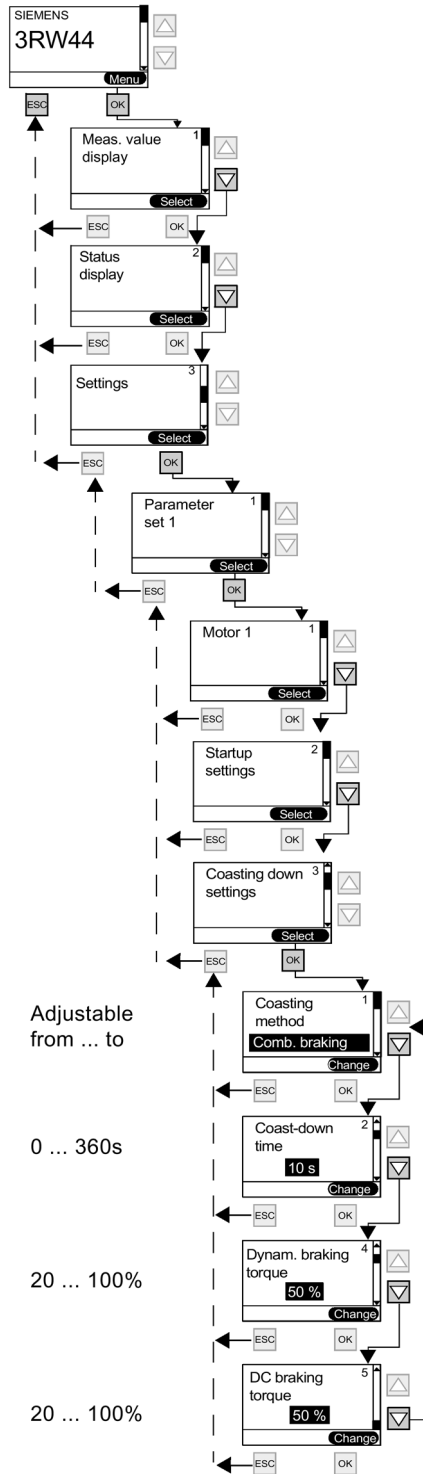

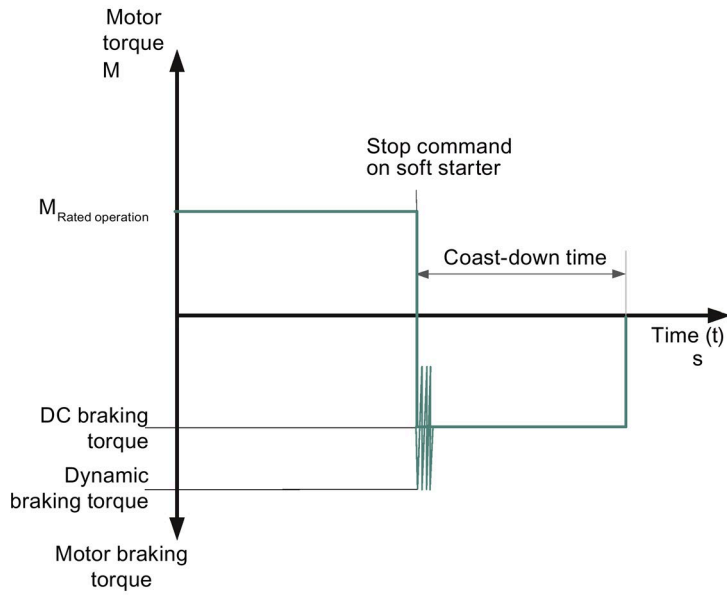

NOTICE

The DC braking/combined braking stopping function is not possible in inside-delta circuits.

6.4.5 Setting slow speed parameters

Setting slow speed parameters

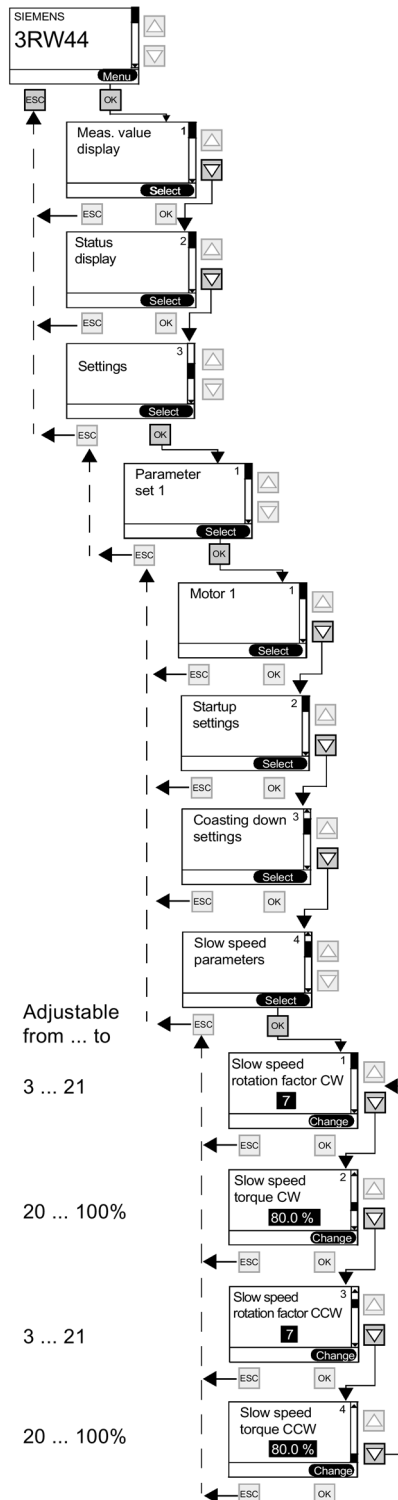

Slow speed parameters

Note

For operation of the motor with the specified slow speed parameters, the "Slow speed" function must be assigned to one control input, and the "Motor CW PS1/2/3" or "Motor CCW PS1/2/3" function must at the same time be assigned to the other. See also Chapter 3RW44 in a standard circuit with soft start/stop and additional slow speed function in both directions of rotation with one parameter set (Page 237).

Directions of rotation:

- Right (CW): rotation in line phase direction
- Left (CCW): rotation opposite to the line phase direction

6.4.6 Specifying current limit values

Specifying current limit values

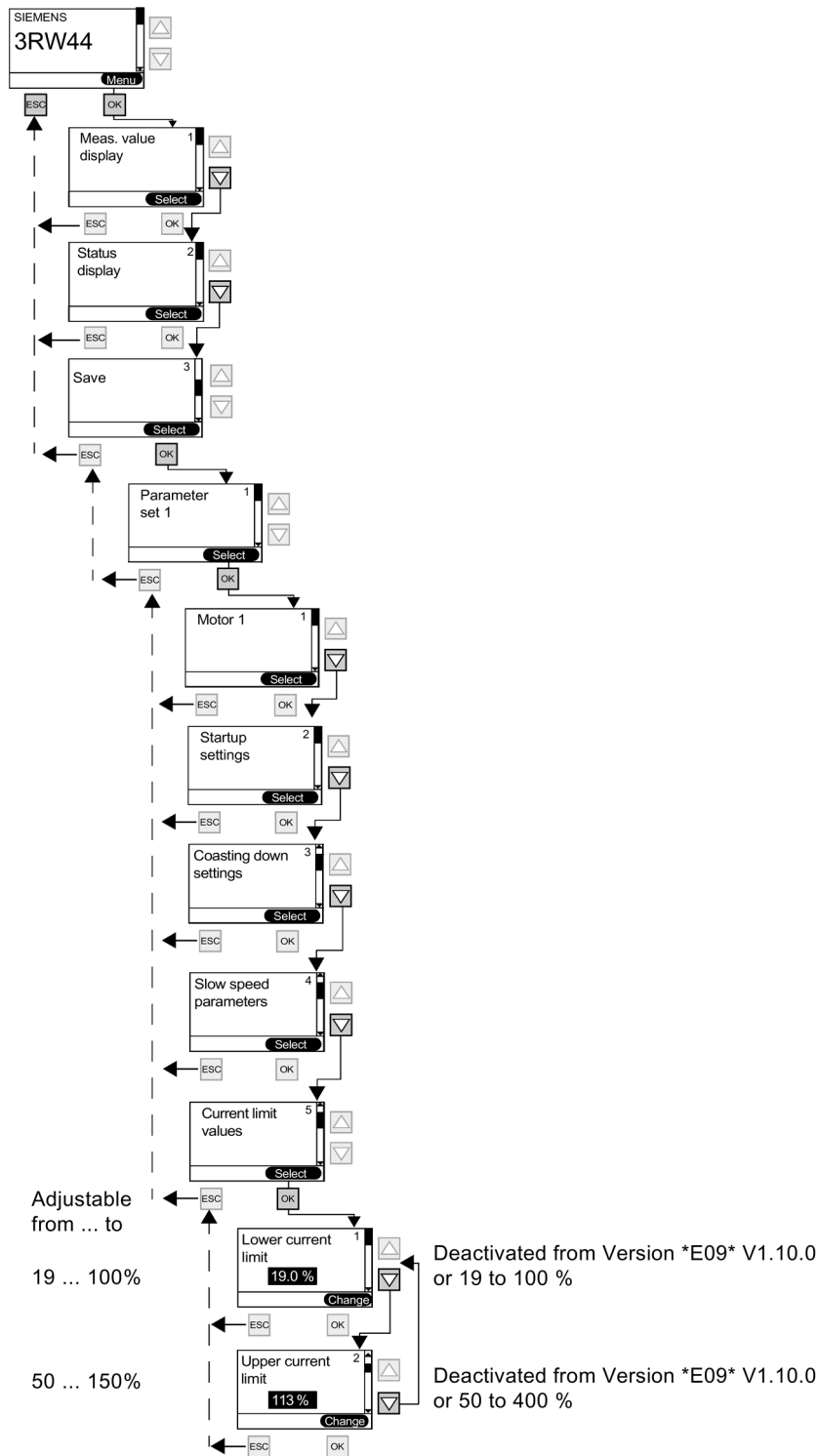

6.4.7 Parameterizing the inputs

Parameterizing the inputs

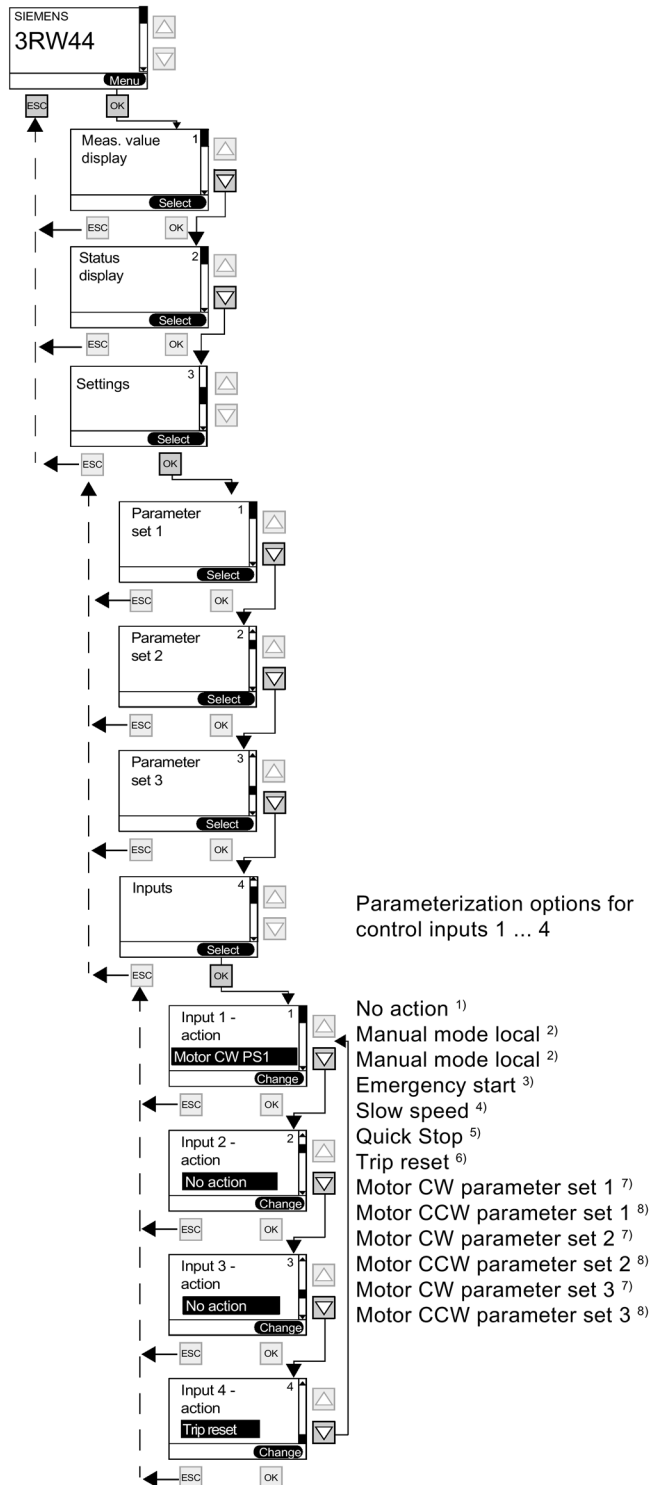

Note

An input action can only be modified when the relevant input is not active.

NOTICE

If the same action is assigned to two different inputs, both of the inputs must also be controlled to carry out the selected function (e.g. to obtain logical "AND" linking for a start command, assign the "Motor CW PS1" function to both inputs 1 and 2. A start command is accepted only if both inputs are active).

NOTICE

If the soft starter is switched off via a motor protection or inherent device protection tripping, the action cannot be acknowledged using the "Trip Reset" function until the displayed cooling time has expired.

Explanation of the possible parameters:

- 1) **No action:** Input has no function.
- 2) **Manual mode local:** During operation with PROFIBUS/PROFINET, control of the soft starter can be transferred to the inputs by activating input control. The control function via PROFIBUS/PROFINET is deactivated during this time.
- 3) **Emergency start:** Error: current unbalance exceeded, thermal motor model overload, temperature sensor open circuit, temperature sensor short circuit, temperature sensor overload, maximum starting time exceeded, I_e exceeded/undershot, ground fault detected, inadmissible I_e class setting: In the case of these faults, the motor can be started via the emergency start function despite a pending group fault. An emergency start action is assigned to one input, and, for example, "Motor CW > parameter set 1" to another. The emergency start is active as long as the input is activated. It can also be activated during operation.
- 4) **Slow speed:** The motor starts with the values set in the "Slow speed parameters" menu item when the "Slow speed" input and the "Motor CW/CCW parameter set 1/2/3" inputs are activated at the same time.
- 5) **Quick stop:** If the input is activated, normal tripping with the currently set stopping function is executed (no group fault appears). The quick stop is executed independently of the control priority.
- 6) **Trip reset:** Pending faults can be acknowledged after rectification.
- 7) **Motor CW parameter set 1/2/3:** The motor starts (with rotation in line phase direction) and stops with the values stored in the respective parameter set.

⁸⁾ **Motor CCW parameter set 1/2/3:** This function is active only when the "Slow speed" parameter is active at the same time. The motor starts with the values stored in the "Slow speed parameters" menu item (with rotation opposite to the line phase direction).

Note

The "Trip Reset" input is edge-controlled. The level change from 0 to 24 V DC is evaluated at the input. All other input functions are evaluated at the already pending 24 V DC level.

6.4.8 Parameterizing the outputs

Parameterizing the outputs

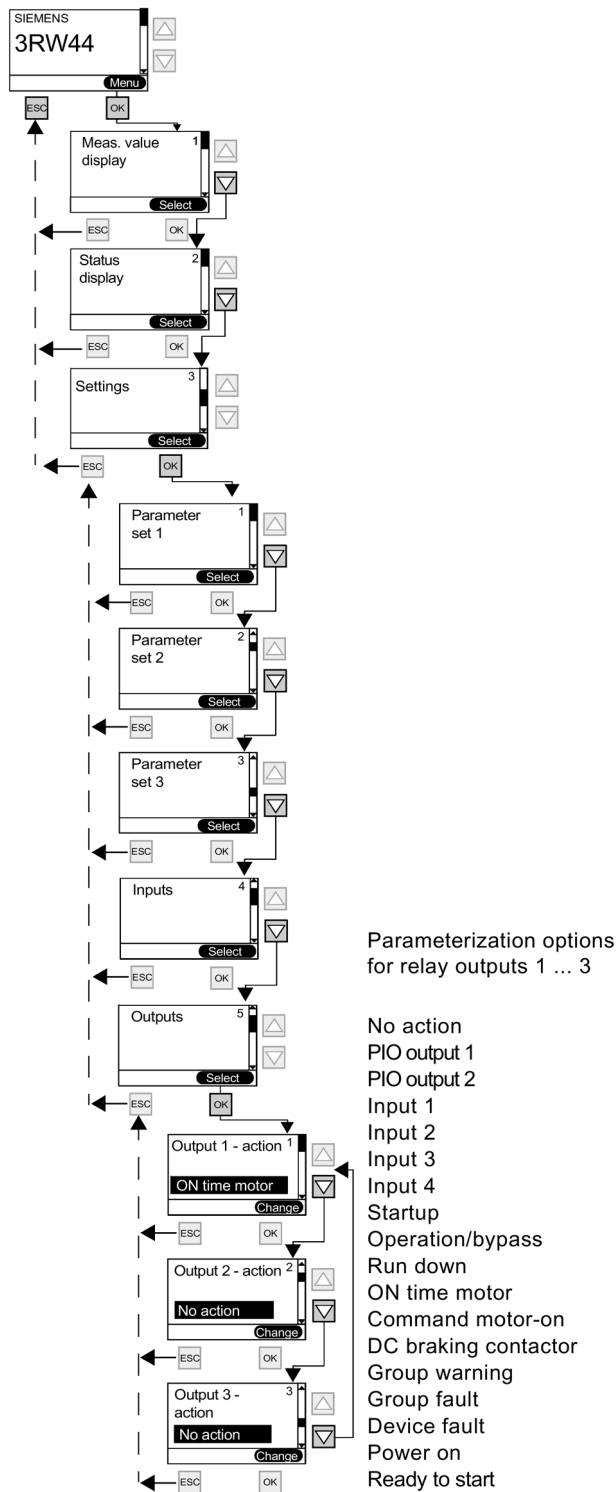

State diagram of the outputs

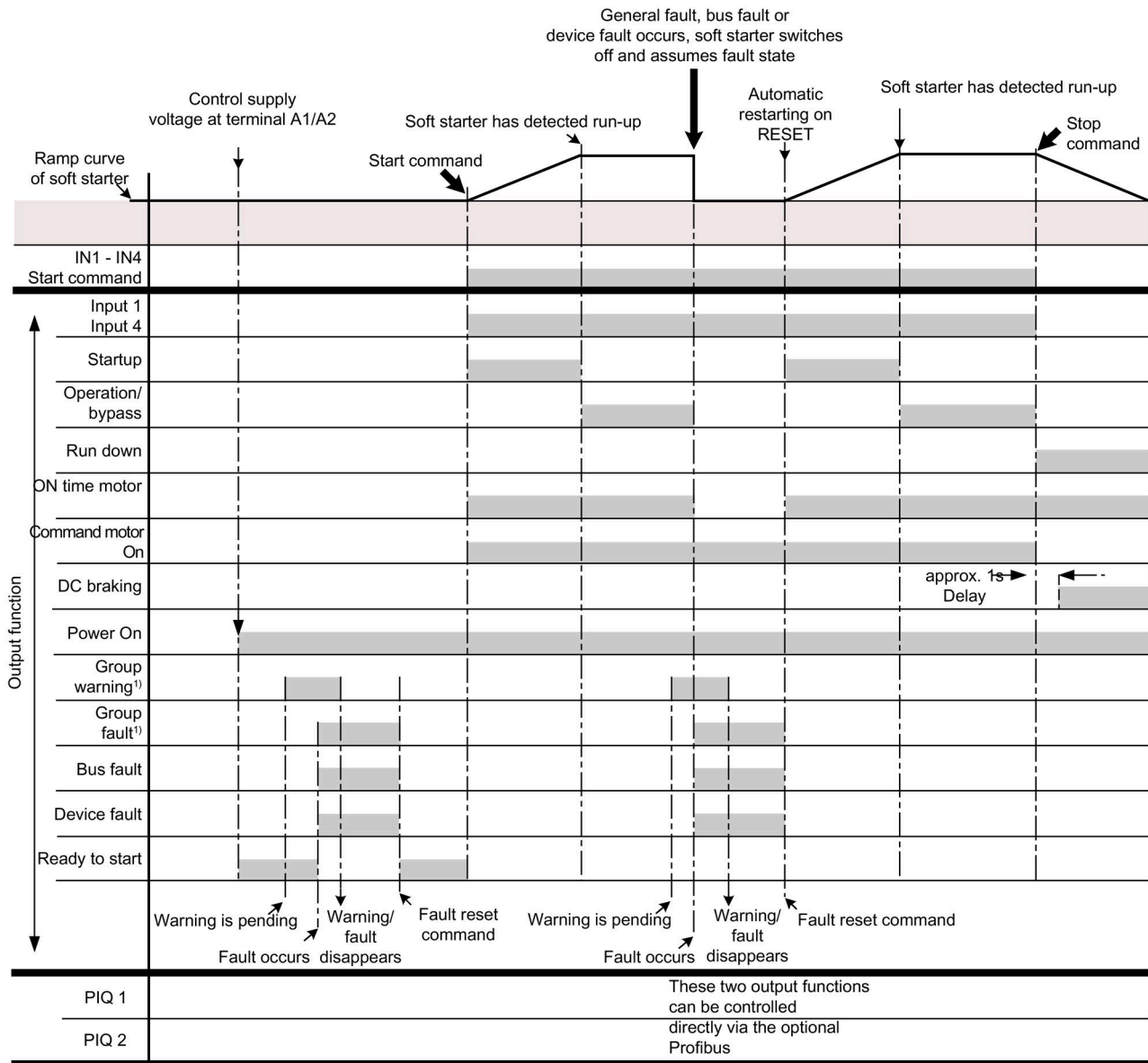

Note

¹⁾ For possible group warnings/group faults, see chapter Warnings and group faults (Page 150).

Note

For switching delay times of the output functions, see chapter Technical data of the control section (Page 279).

6.4.9 Selecting motor protection settings

Selecting motor protection settings

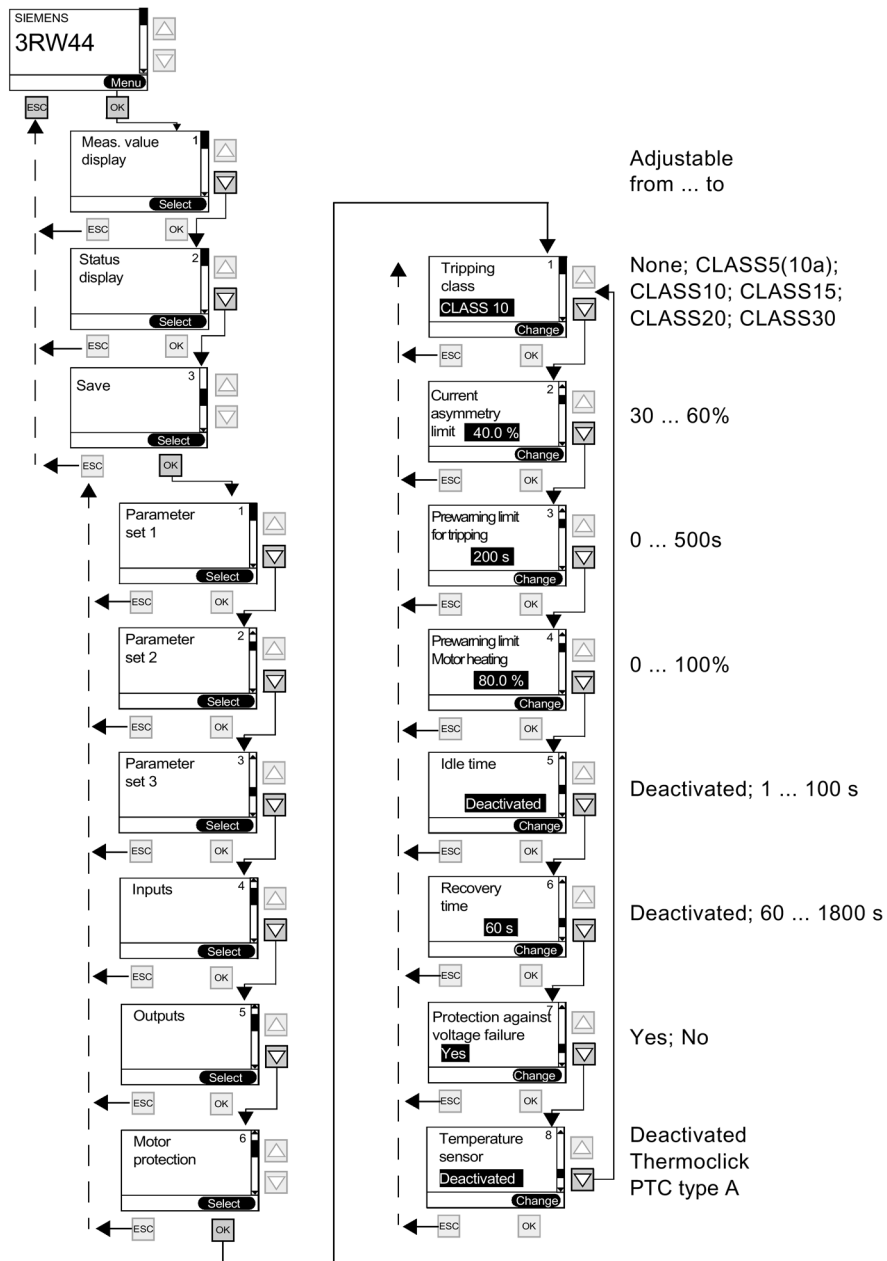

NOTICE

In the case of heavy starting and set values of tripping class \geq CLASS 20, we recommend setting the "Prewarning limit tripping reserve" parameter value to 0 s (deactivated) and increasing the "Prewarning limit motor heating" parameter to 95 %. Otherwise, a motor protection warning will be issued when starting.

NOTICE

If a CLASS setting other than 5(10a) or 10 is selected, it may be necessary to check and adjust the set values for the rated operating current I_e of the motor (chapter Entering the motor data (Page 66)) in all 3 parameter sets, since otherwise the "Impermissible I_e /CLASS settings" error message may be issued.

For the maximum permissible set value for the rated operating current I_e of the motor based on the CLASS settings, refer to chapter Technical data of the power unit (Page 274).

NOTICE

Use of the 3RW44 to operate motors in hazardous areas:

The 3RW44 does not have ATEX certification. When an ATEX-certified overload relay is used (e.g. 3RB2 from Siemens) that affects an additional switching element (e.g. contactor), the 3RW44 can be installed in series with this overload relay, meaning that the ATEX requirements are met.

NOTICE

The internal motor overload protection of the SIRIUS 3RW44 soft starter must be deactivated for this kind of installation! (Set value in the "Motor protection/Tripping class" menu item: "None" and Motor protection/Temperature sensor: "Deactivated")

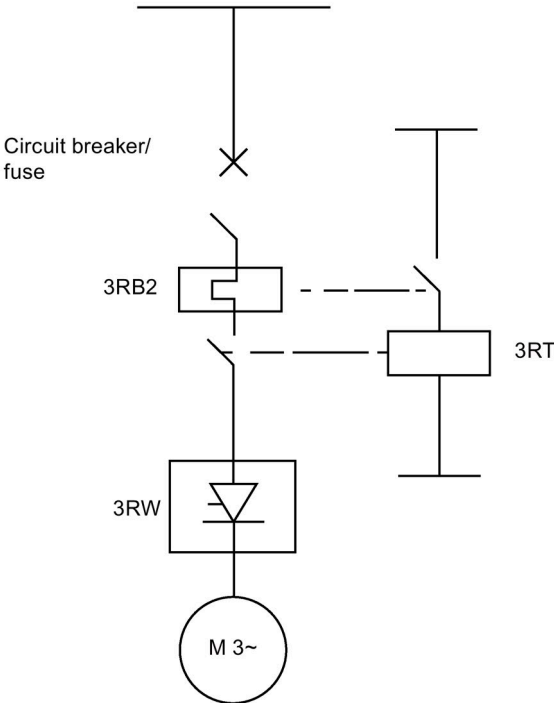

6.4.10 Selecting display settings

Selecting display settings

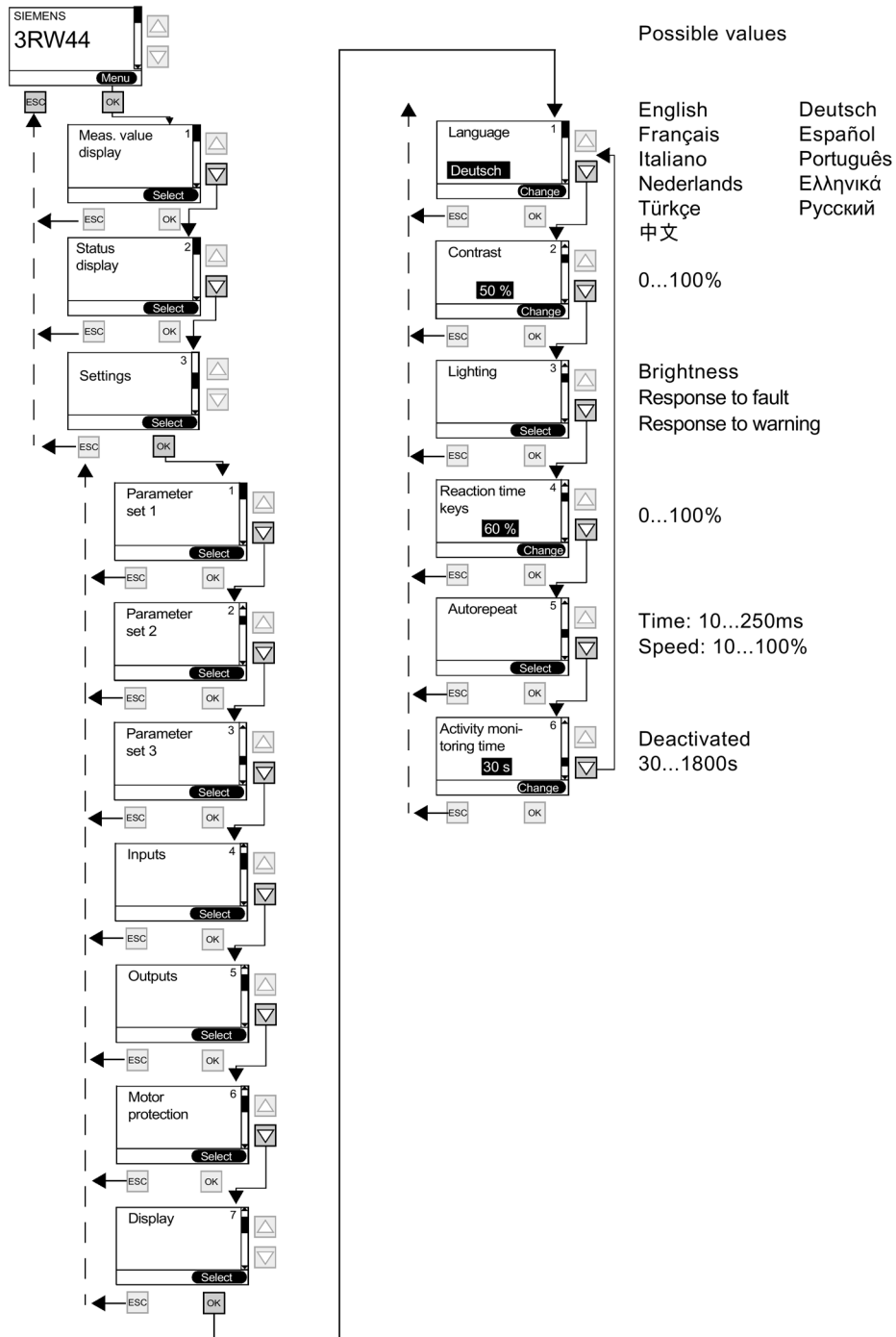

6.4.11 Specifying the behavior of the protective functions

Specifying the behavior of the protective functions

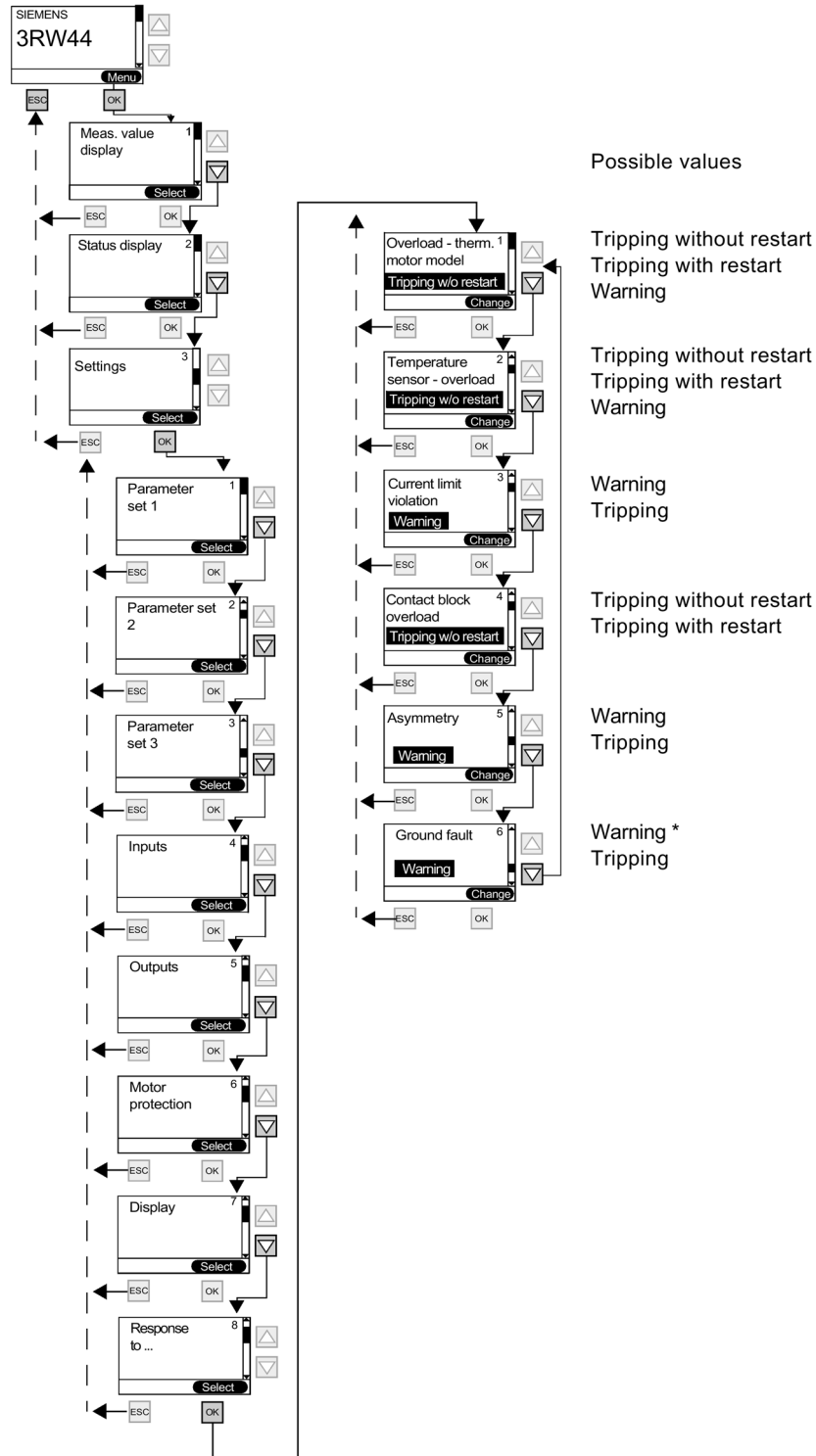

Note

* The ground fault function is only active after completion of run-up, not during startup.

6.4.12 Specifying the names on the device display

Specifying the names on the device display

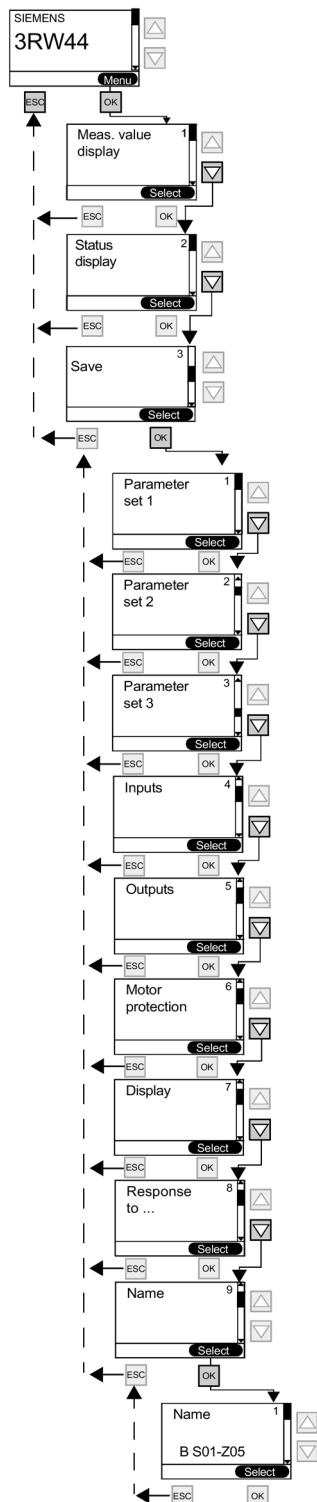

6.4.13 Activating the fieldbus interface (PROFIBUS DP/PROFINET IO)

For activation of the fieldbus interface, see chapter Activating the PROFIBUS DP communication module (fieldbus interface) and setting the station address (Page 166).

PROFIBUS DP is shown in the example:

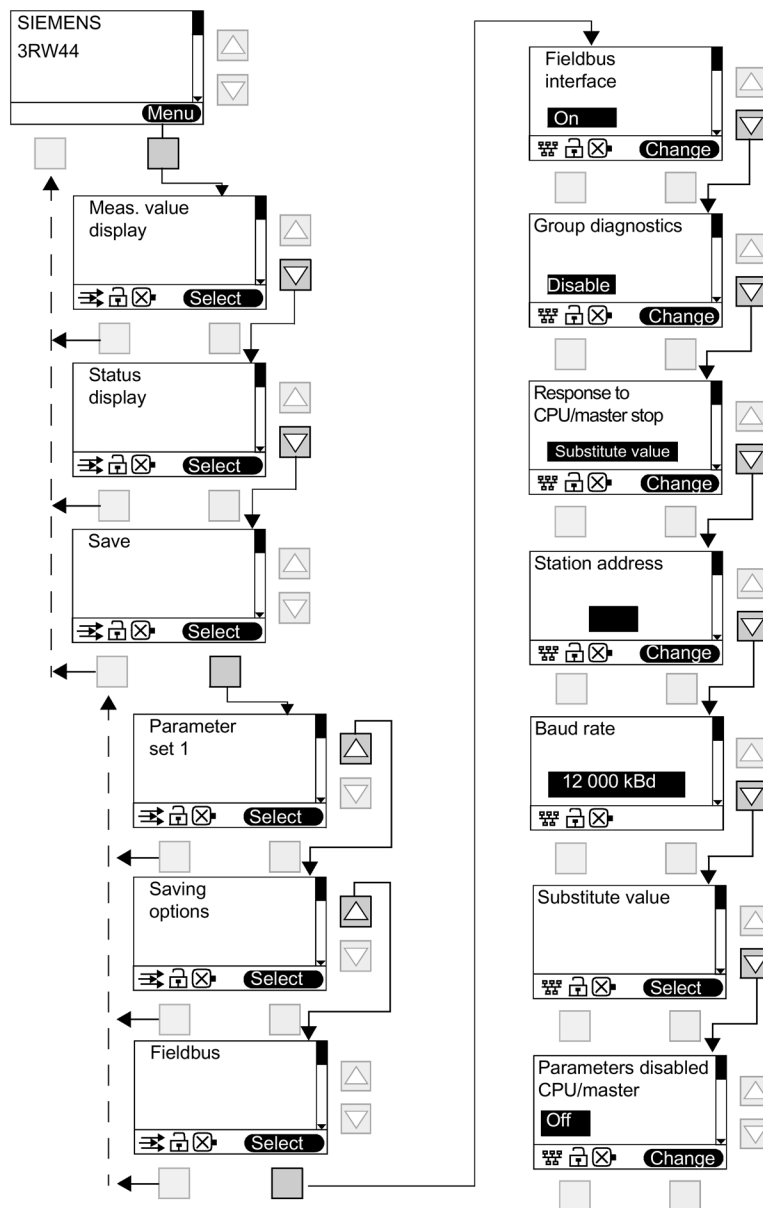

Note

If the "Parameters disabled CPU/Master" parameter is set to "Off" (factory setting), the parameters set on the soft starter will be overwritten with the values stored in the GSD file or in the OM when the bus is started. If this is not desired, the parameter must be set to "On".

6.4.14 Saving options

Specifying the saving options

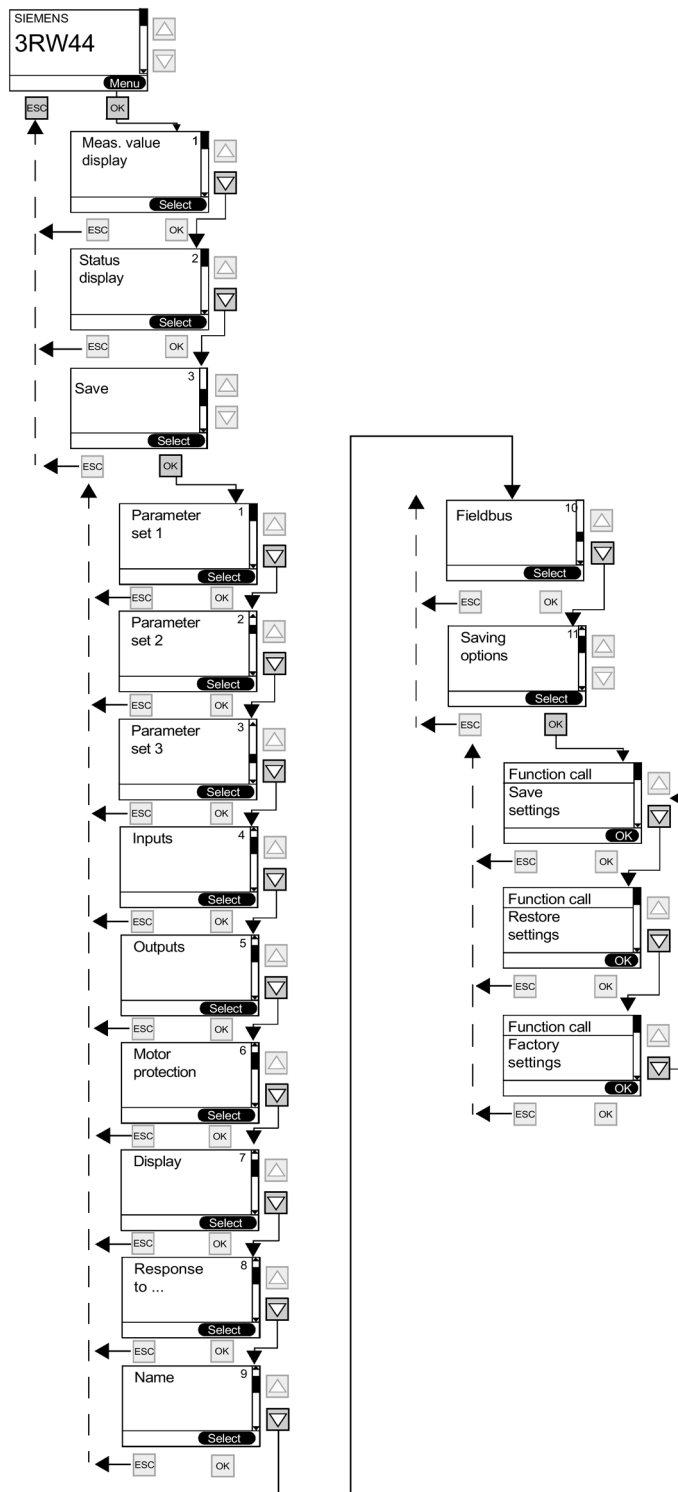

NOTICE

As long as the connected drive is controlled by the soft starter, no parameter changes carried out at the same time can be saved by means of the "Saving options" menu item. This is only possible after the motor has been shut off by the soft starter.

Saving settings

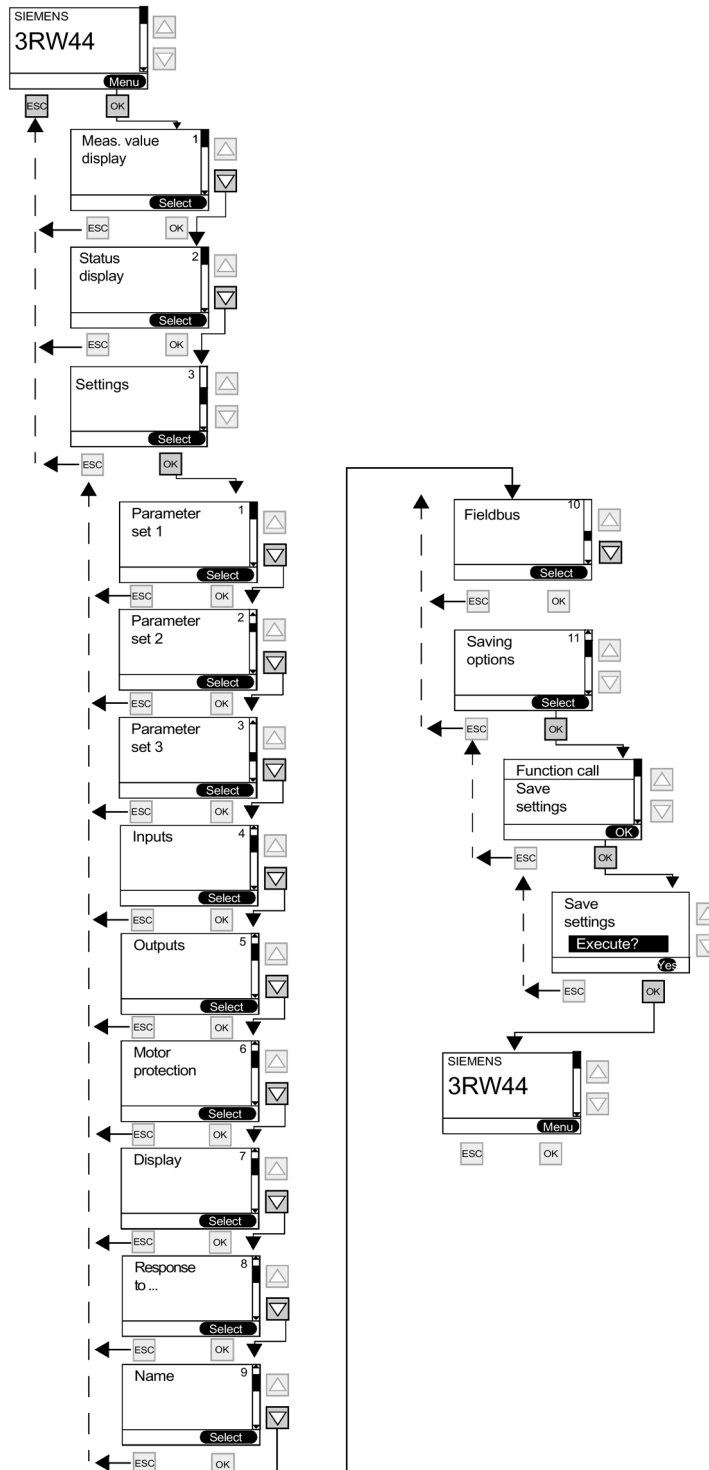

Restoring settings

Selected settings that have not been saved will be discarded and the previously saved settings will be restored.

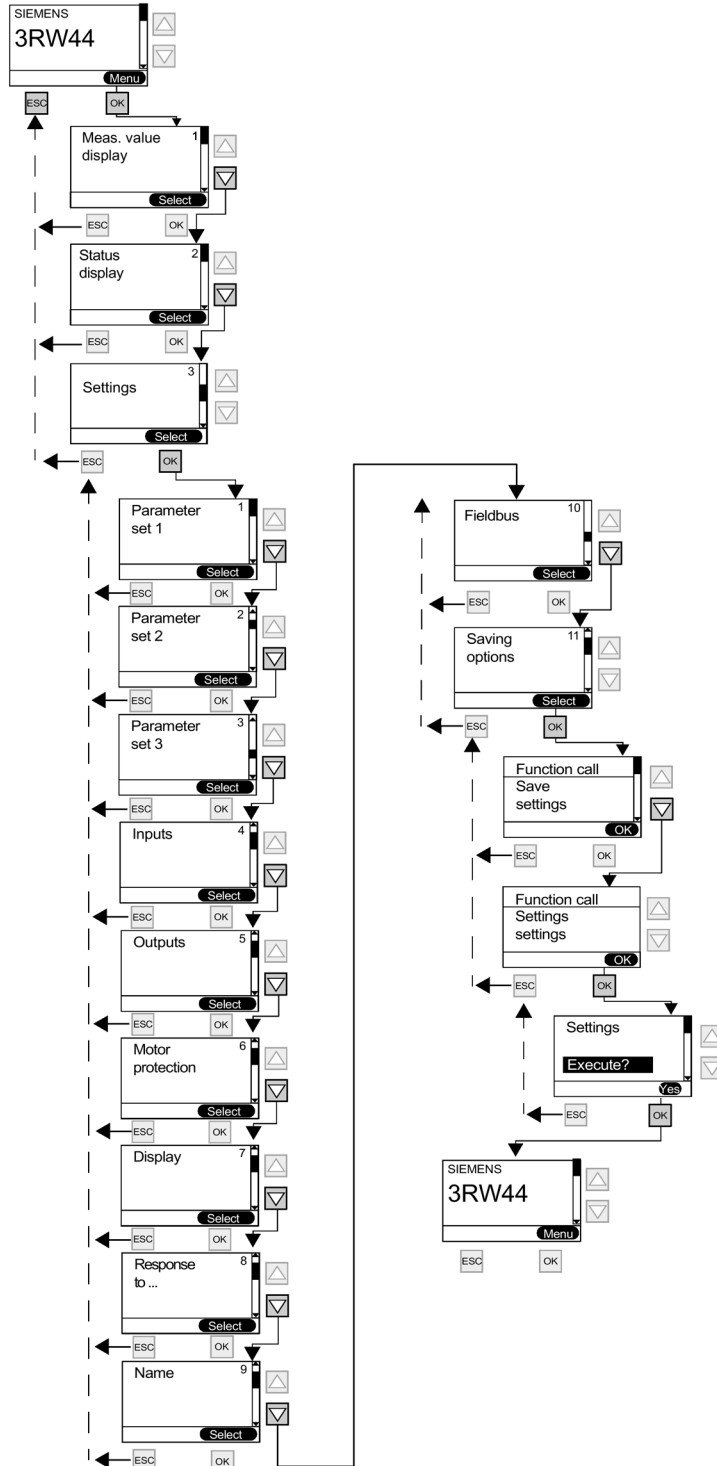

Restoring the factory settings

All settings made or saved so far will be discarded and the device will be reset to the basic factory settings (master reset). The quick start menu must be executed once again.

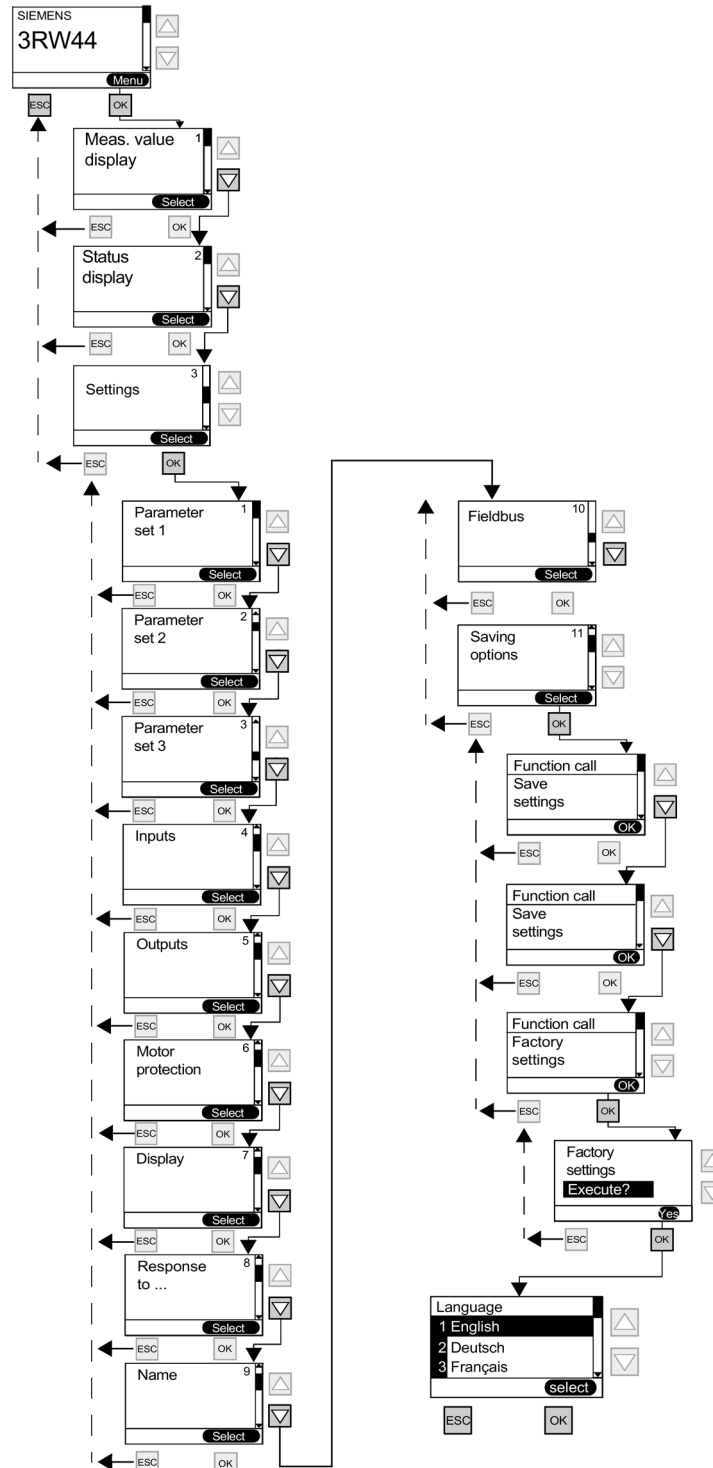

6.5 Other device functions

6.5.1 Measured values display

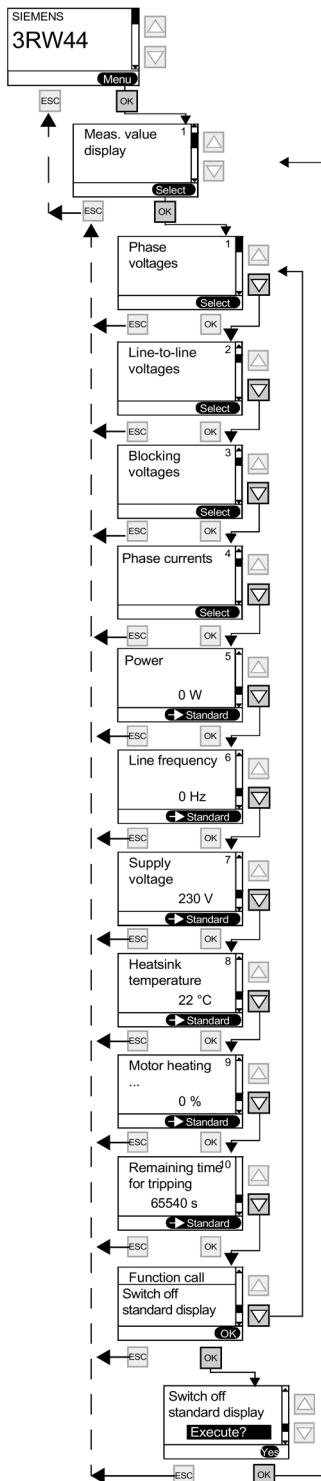

Note

When using the 3RW44 soft starter in an IT system with ground fault monitoring: 3RW44, product version < *E06* and the PROFIBUS DP communication module must not be used in this network configuration. 3RW44 soft starters from product version *E07* onwards can be used in combination with the PROFIBUS DP communication module. However, the phase voltage values (UL-N) and phase-to-phase voltage values (UL-L) may be displayed incorrectly on the measured value display of the 3RW44.

Note

PROFINET communication modules can only be used with a product version of *E12* or later.

Note

The "Phase currents" display always shows the currents in the supply cable. This means that, if the soft starter is operated in the "Inside-delta circuit" circuit type, the currents measured internally by the soft starter are extrapolated to the supply cable current (phase current) by a factor of 1.73 and are displayed.

Due to unbalance, the phase currents displayed in the inside-delta circuit may deviate from the currents that are actually running through the supply cables.

6.5.2 Status display

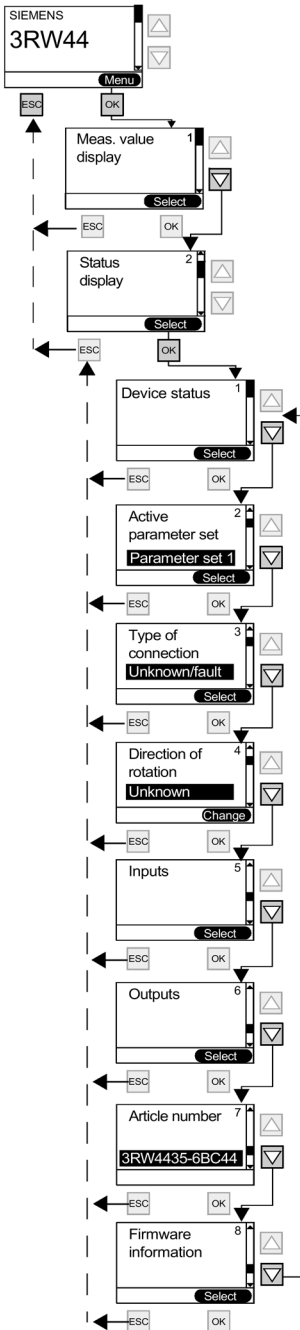

Explanation of the messages:

Unknown/fault: No connected motor detected.
 Star/delta: Soft starter connected in a standard circuit.
 Inside-delta: Soft starter connected in an inside-delta circuit.

Unknown: No line phase direction of the main voltage detected at terminals L1-L2-L3.
 Right (CW): clockwise line phase direction of the main voltage detected at terminals L1-L2-L3.
 Left (CCW): Counter-clockwise line phase direction of the main voltage detected at terminals L1-L2-L3.

Outputs 1 - 3: Function corresponds to parameterization
 Output 4: Group fault
 Output 5: Internal bypass contactor connected
 Output 6: Device fan activated

6.5.3 Motor control (assigning control priority)

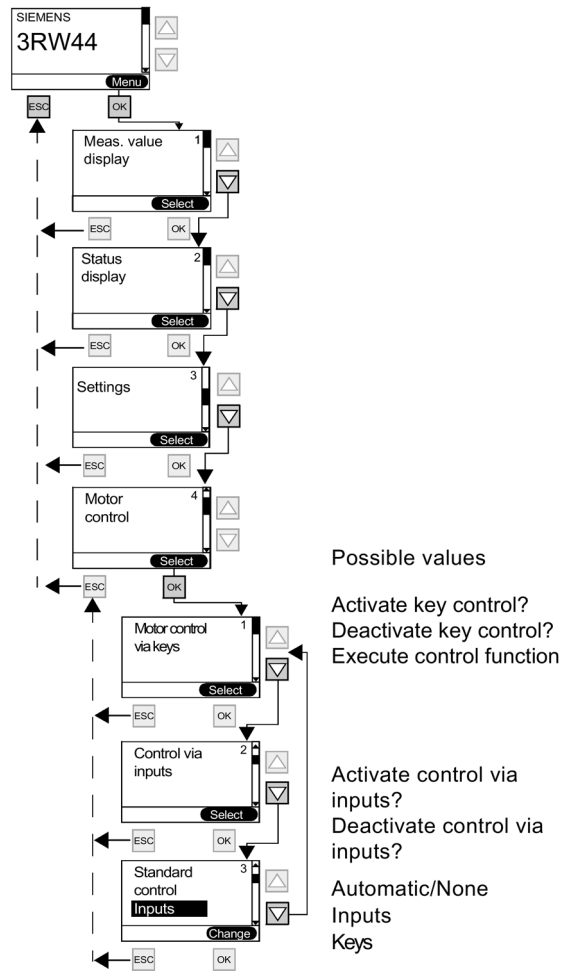

Figure 6-1 Motor control

NOTICE

The "Standard control" menu item specifies which control device should be given control priority when the control supply voltage is applied.

When the PROFIBUS/PROFINET communication module is activated, the setting is changed to "Automatic/None".

Control device priority

Only a higher-priority control device can assume and hand over the control priority (0 = lowest).

- - 0: Automatic operation (input control through PLC via PROFIBUS/PROFINET)
- - 1: PC via PROFIBUS/PROFINET (Soft Starter ES professional software required)
- - 2: Inputs
- - 3: Via display keys
- - 4: PC via serial interface (Soft Starter ES smart software required)

6.5.4 Statistics

Statistics

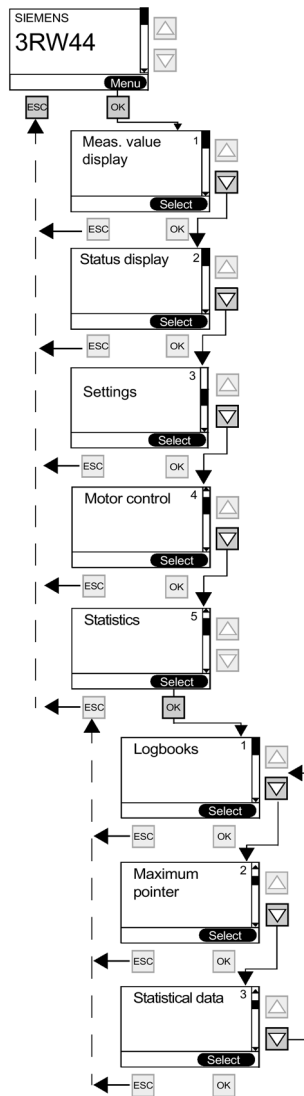

NOTICE

The "Statistics" menu item is available for devices with firmware product version *E04* or higher. The firmware product version is listed on the front of the device below the petrol-colored labeling field. The "Logbooks" sub-item can only be used in combination with "Soft Starter ES" parameterizing and diagnostics software. This menu item will be available in the device display from 04/2006.

Logbooks

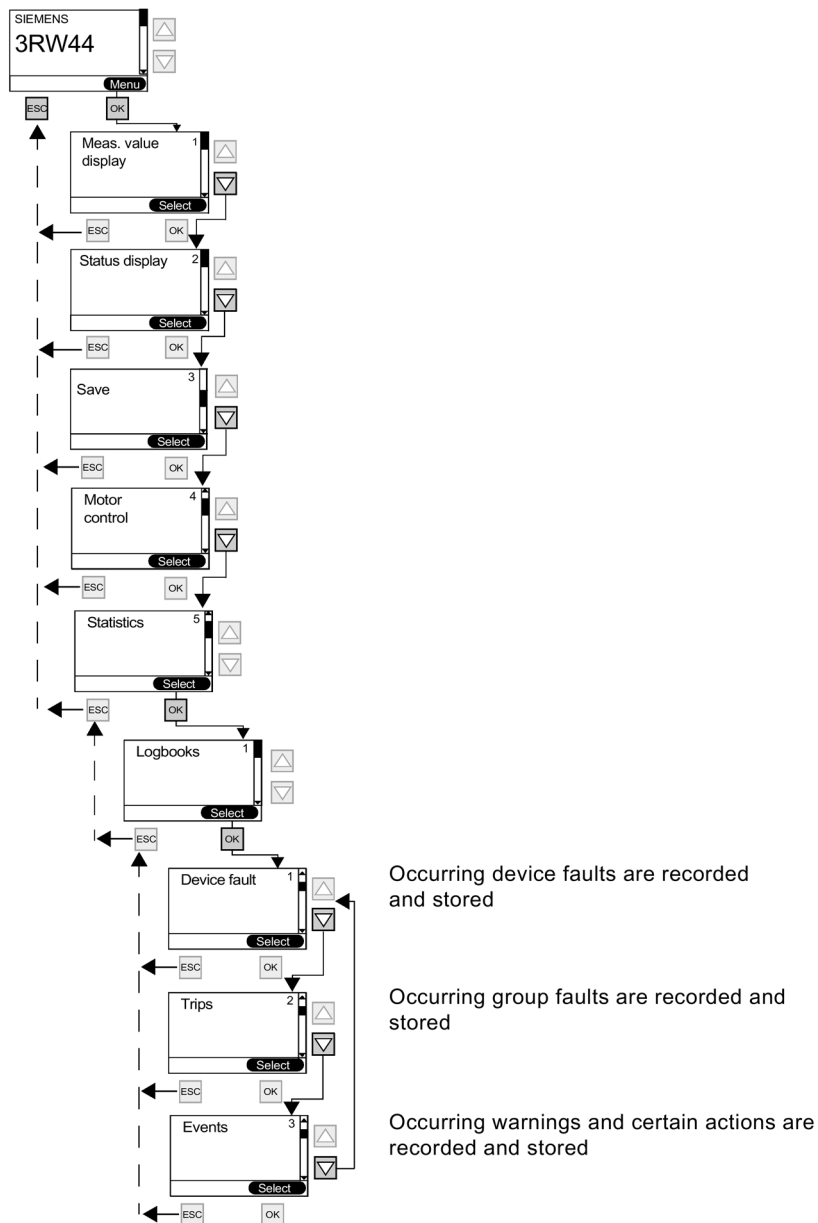

Note

The "Statistics" menu item is available for devices with firmware product version *E04* or higher. The firmware product version is listed on the front of the device below the petrol-colored labeling field. The "Logbooks" sub-item can only be used in combination with "Soft Starter ES" parameterizing and diagnostics software. This menu item will be available in the device display from 04/2006.

Note

Logbooks cannot be deleted while the motor is running.

Maximum pointer (minimum and maximum measured values are stored and displayed)

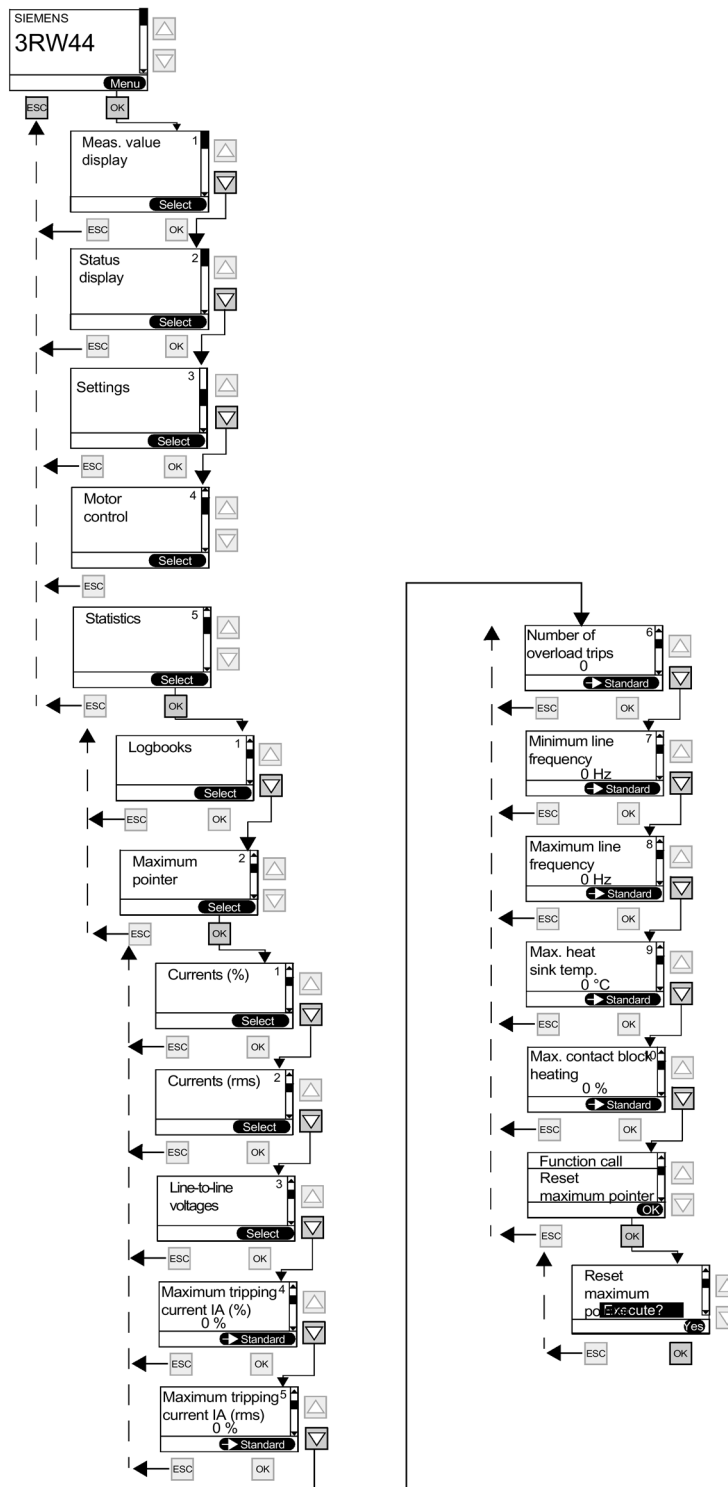

NOTICE

The "Statistics" menu item is available for devices with firmware product version *E04* or higher. The firmware product version is listed on the front of the device below the petrol-colored labeling field. The "Logbooks" sub-item can only be used in combination with "Soft Starter ES" parameterizing and diagnostics software.

Statistical data

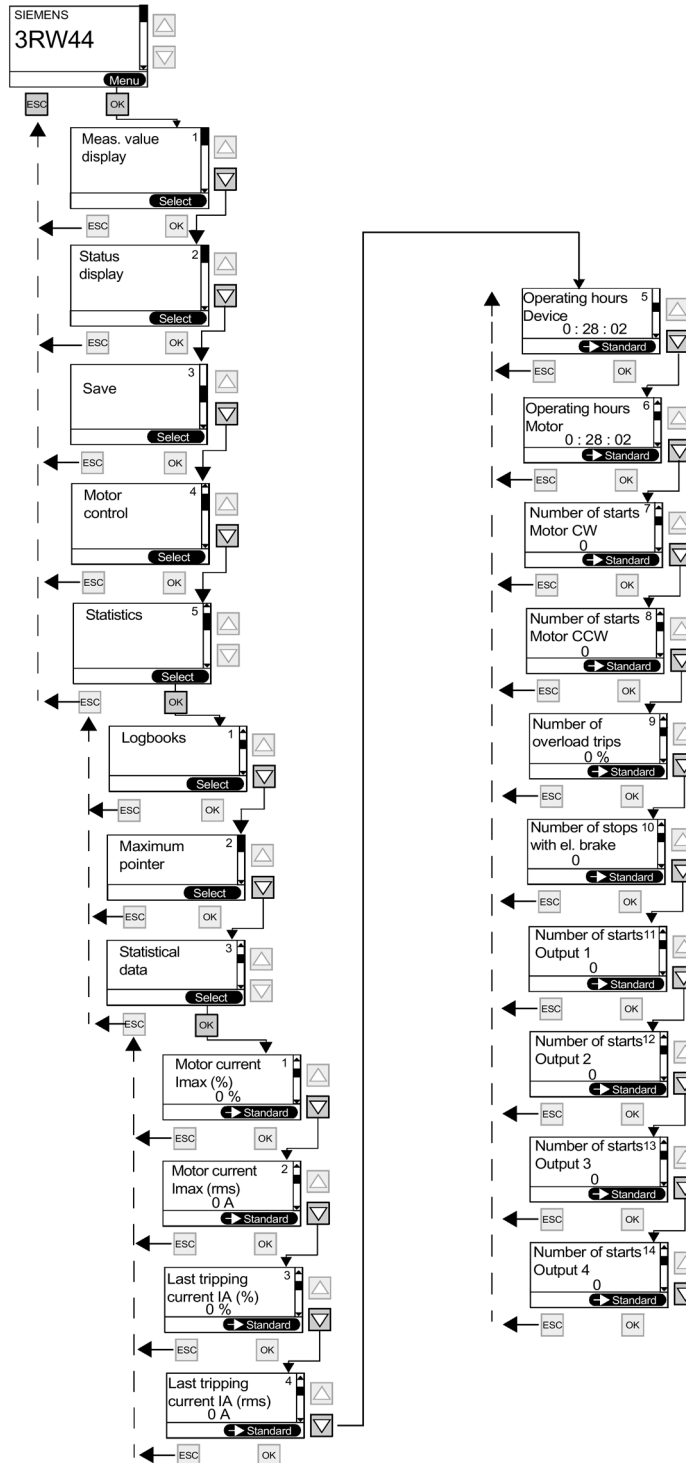

NOTICE
The "Statistics" menu item is available for devices with firmware product version *E04* or higher. The firmware product version is listed on the front of the device below the petrol-colored labeling field. The "Logbooks" sub-item can only be used in combination with "Soft Starter ES" parameterizing and diagnostics software.

Note

Number of starts motor CCW, only possible in combination with slow speed.

Note

Number of stops with el. brake: The value is incremented by 1 when braking has been chosen as the coasting method.

Note

The value is incremented by 1 each time the output is set.

Note

The operating hours counter is activated as soon as control voltage is applied to the soft starter. Maximum value displayed: 99999:59:59 hours

6.5.5 Safety (specifying the user level, parameterization protection)

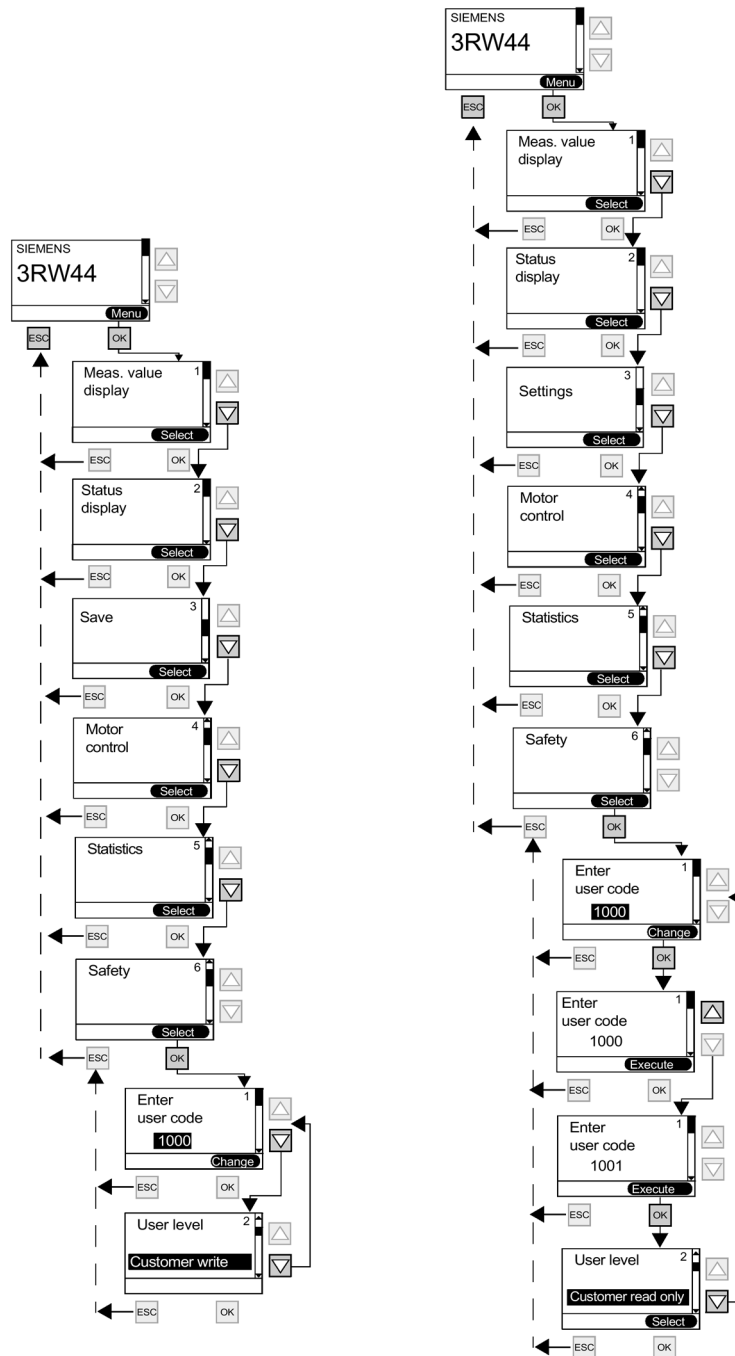

Device functions

7.1 Various parameter sets

7.1.1 Various parameter sets

The soft starter provides three individually adjustable parameter sets. One startup mode and one coasting method can be selectively determined for each parameter set.

Applications

- Starting Dahlander motors (variable-speed drive).
- Starting an application with different load conditions (e.g. empty or full conveyor belt).
- Separate starting of up to three drives with different run-up behavior (e.g. compressor and pump).

7.2 Startup modes

Different starting functions can be selected thanks to the large number of applications for which the SIRIUS 3RW44 soft starter can be used. The motor start can be optimally adapted to each particular application.

7.2.1 Voltage ramp

The simplest type of soft start with the SIRIUS 3RW44 soft starter is achieved using a voltage ramp. The motor's terminal voltage is raised during an adjustable starting time from a parameterizable starting voltage to the line voltage. This startup mode is preset in the quick start menu.

Starting voltage

The starting voltage determines the starting torque of the motor. A lower starting voltage results in a lower tightening torque and a lower starting current. The starting voltage should be selected such that the motor starts up immediately and smoothly once the start command goes to the soft starter.

Starting time

The length of the starting time determines the time during which the motor voltage is increased from the parameterized starting voltage to the supply voltage. This has an influence on the motor's acceleration moment, which drives the load during the ramp-up operation. A longer starting time has a smaller acceleration moment throughout the motor ramp-up. The latter is therefore longer and smoother. The length of the starting time should be selected so that the motor reaches its rated speed within this period. If the time selected is too short, in other words if the starting time ends before the motor has started up successfully, a very high starting current that equals the direct starting current at the same speed occurs at this instant. The soft starter can, in this case, switch itself off via the internal overload protection function and go into fault mode.

Maximum starting time

The "Maximum starting time" parameter can be used to determine the time after which the drive must have completed its run-up. If the drive is not operating under rated service conditions after the specified interval has expired, the startup procedure is interrupted and a fault message is generated.

Internal run-up recognition

The soft starter features internal run-up recognition. If the device recognizes a completed motor run-up, the internal bypass contacts close and the thyristors are bridged. If this run-up recognition is performed before the set starting time is completed, the ramp is canceled and the motor voltage is immediately increased to 100 % of the line voltage before the internal bypass contacts are closed.

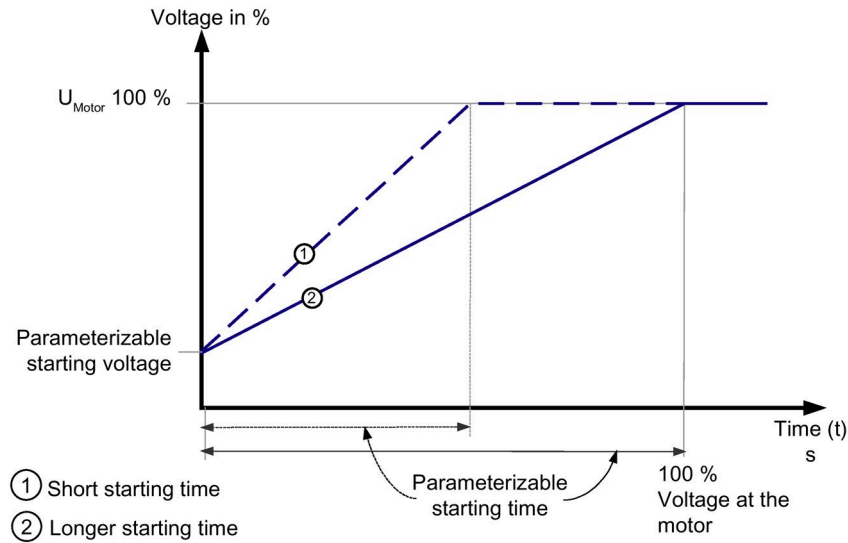

Figure 7-1 Function principle of the voltage ramp

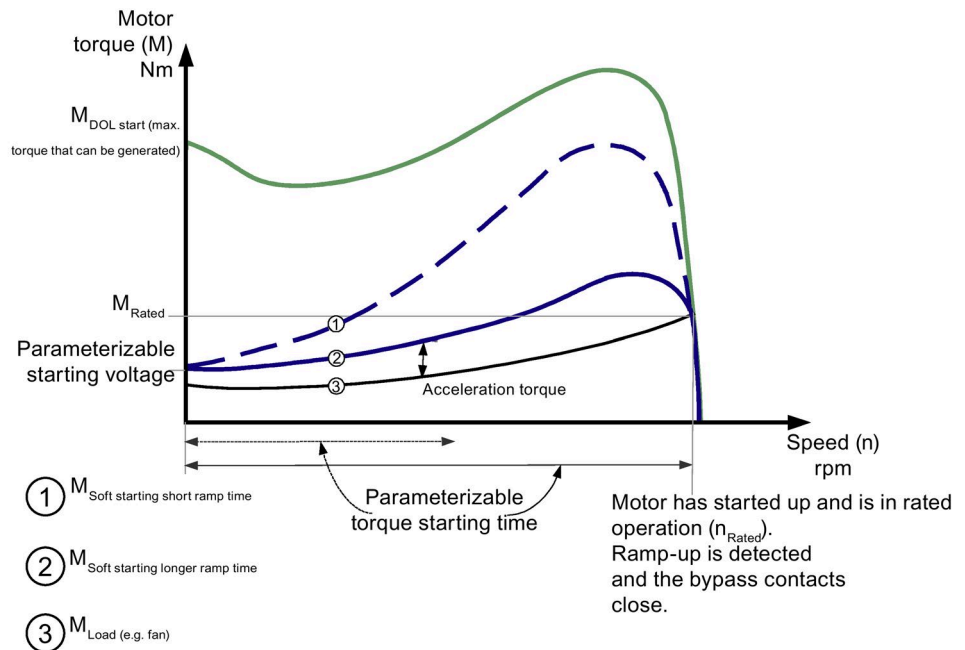

Figure 7-2 Principle of the voltage ramp for the torque characteristic

Typical applications for voltage ramps

The voltage ramp function principle is suitable for all types of application. If test runs with the application are carried out using motors that are smaller than those to be used in the actual system, we recommend using the "Voltage ramp" startup mode. For machines requiring a breakaway pulse (inverse load response, e.g. in mills or crushers), the breakaway pulse must be set as described in chapter Breakaway pulse in combination with the voltage ramp or torque control startup mode (Page 130). The "Voltage ramp+current limiting (U+current limiting)" startup mode is recommended for heavy starting.

7.2.2 Torque control

The motor speed and torque are calculated using the voltage and current rms values, as well as the associated phase information between the line voltage and the motor current ($= \cos \phi$) = sensorless control), and the motor voltage is controlled accordingly.

Torque control means that the torque generated in the motor is linearly increased from a parameterizable starting torque up to a parameterizable end torque within an adjustable starting time.

The advantage over the voltage ramp is the improved mechanical run-up behavior of the machine.

The soft starter controls the torque generated at the motor continuously and linearly according to the set parameters until the motor has completely run up.

For optimum torque control during the starting procedure, the motor data of the motor connected to the soft starter should be entered in the selected parameter set using the "Setting" menu item.

Starting torque

The starting torque determines the switch-on torque of the motor. A lower starting torque results in a lower locked-rotor torque and a lower starting current. The starting torque selected must be sufficiently high to ensure that the motor starts straight away and smoothly when the start command is issued to the soft starter.

Limiting torque

The limiting torque value specifies the maximum torque to be generated in the motor during startup. This value also functions as an adjustable torque limit, for example.

The parameter value should be set to approx. 150 % to start the motor. It should be high enough to ensure that the motor does not become stuck during run-up. This ensures that enough acceleration torque is generated throughout the motor run-up phase.

Typical applications for torque control

Torque control is suitable for all applications, especially in cases where uniform and smooth startup is required. For machines requiring a breakaway pulse (inverse load response, e.g. in mills or crushers), the breakaway pulse must be set as described in chapter Breakaway pulse in combination with the voltage ramp or torque control startup mode (Page 130). The "Torque control+current limiting (M+current limiting)" startup mode is recommended for heavy starting (refer to chapter Current limitation in combination with the voltage ramp or torque control startup mode (Page 132)).

7.2.3 Breakaway pulse in combination with the voltage ramp or torque control startup mode

This function is required for load machines with inverse torque behavior. Typical applications are mills, crushers or drives with plain bearings. In such cases, it may be necessary to create a breakaway pulse at the beginning of the machine's start process. The breakaway pulse is set via the breakaway voltage and the breakaway time. Using the breakaway pulse, the high limiting friction of the load can be overcome and the machine can be set into motion.

The breakaway pulse is used in conjunction with the start type of the voltage ramp, the torque control, or the current limitation and overlays this during the set breakaway time.

Breakaway voltage

The breakaway voltage is used to set the breakaway torque to be generated. The breakaway torque can be up to 100% of the locked-rotor torque generated during direct-on-line starting. The pulse must be high enough to ensure that the motor starts rotating as soon as the start command is issued to the soft starter.

Breakaway time

The breakaway time determines the period during which the breakaway voltage is to be present. Once the breakaway time has expired, the soft starter ends its run-up procedure with the selected startup mode, e.g. the voltage ramp or torque control. The selected breakaway time should be at least long enough so that, after the set time has elapsed, the motor does not remain stationary again but rather directly continues to accelerate in the selected startup mode

If 0 ms is set as the breakaway time (default), the breakaway pulse function is deactivated.

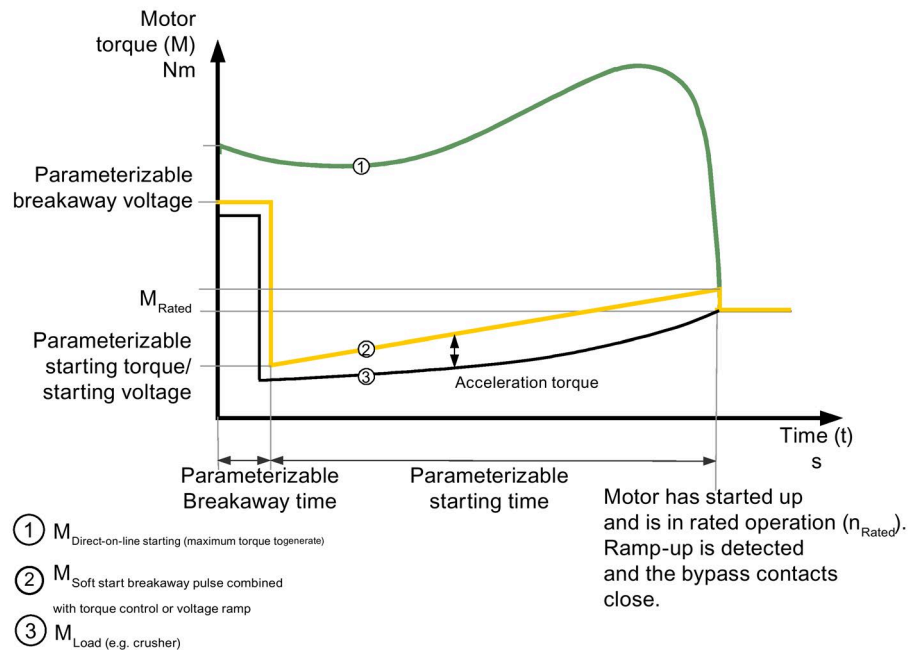

Figure 7-4 Function principle of torque control breakaway pulse

Typical applications for breakaway pulses

Typical applications for breakaway pulses are load machines with inverse torque behavior, e.g. crushers and mills.

Note

A breakaway pulse that is set too high may lead to the "Current measurement range exceeded" error message.

Remedy: use a larger starter dimension or a lower breakaway voltage.

Set the breakaway pulse only when it is really required (e.g. for mills and crushers).

A wrongly set breakaway pulse, e.g. for pumps, may lead to the "Incorrect start conditions" error message.

7.2.4 Current limitation in combination with the voltage ramp or torque control startup mode

The starter measures the phase current (motor current) continuously with the help of integrated current transformers.

A current limiting value can be set on the soft starter while the motor is starting up.

Current limiting can be activated when "voltage ramp + current limiting" or "torque control + current limiting" has been selected as the startup mode and a value has been entered in the applicable parameter.

During starting, the phase current is limited to the set value until this value is undershot. A set breakaway pulse is superimposed on the current limitation during the breakaway time.

Current limiting value

The current limiting value is set as a factor of the rated motor current to the maximum current required during startup. Once the selected current limiting value has been reached, the motor voltage is reduced or controlled by the soft starter to prevent the current from exceeding the set current limiting value. The set current limiting value must be high enough to ensure that the torque generated in the motor is sufficient to accelerate the motor to nominal speed. Three to four times the value of the motor's rated operational current (I_e) can be assumed as typical here.

Ramp-up detection

The soft starter features internal run-up recognition. If it detects a motor ramp-up, the motor voltage is immediately increased to 100% of the line voltage. The internal bypass contacts close and the thyristors are bridged.

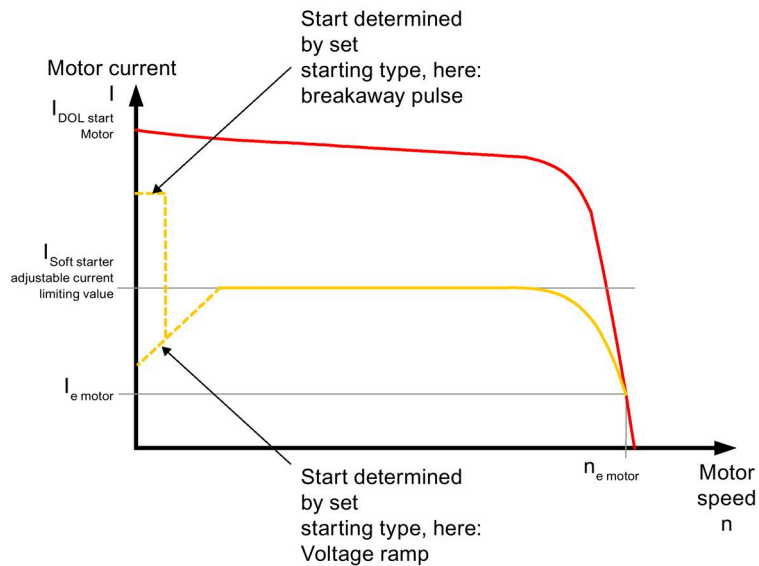

Figure 7-5 Current limiting with soft starter

Typical applications for current limiting

Current limiting is used for applications with a large centrifugal mass (mass inertia) and therefore long starting times, e.g. large fans, to reduce the load on the power supply system.

7.2.5 Direct startup mode

If the "Direct" startup mode is set, the motor voltage is increased immediately to the level of the supply voltage once the start command has been issued. This is equivalent to the start behavior with a contactor, i.e. no limitation of the starting current and the starting torque.

Note

Due to the motor's high starting current, the "current limit exceeded" fault can occur in the case of the "direct" startup mode. It may be necessary to select a larger soft starter.

Ramp-up detection

The soft starter features internal ramp-up detection. If a completed motor ramp-up is detected, the internal bypass contacts close and the thyristors are bridged.

7.2.6 Motor heating startup mode

If IP54 motors are used outdoors, condensation forms in the motor when it cools down (e.g. overnight or in the winter). This can result in leakage currents or short-circuits when the motor is switched on.

To heat the motor winding, a pulsating direct current is injected into it.

When the "motor heating" startup mode is selected, a heating power can be entered in the settings. This should be selected so that the motor is not damaged. The heating power setting range is from 10 - 100 %. This corresponds to a comparable motor current of about 5 - 30 % of the rated motor current.

Typical applications for motor heating

For example, used for drives outdoors to minimize condensation inside the motor.



CAUTION

May lead to damage to property.

The motor heating startup mode is not a continuous operating mode. The motor must be equipped with a temperature sensor (Thermoclick/PTC) to ensure motor protection. The motor model with integrated electronic motor overload protection is not suitable for this kind of operation.

7.3 Coasting methods

Different coasting methods can be selected thanks to the large number of applications for which the SIRIUS 3RW44 soft starter can be used. The motor stop can be optimally adapted to each particular application.

If a start command is issued during the stop process, the process is interrupted and the motor is started again with the set startup mode.

Note

If you select a controlled stop (soft stop or pump stop or braking) as the coasting method, the feeder (soft starter, cables, feeder protective devices, and motor) may need to be dimensioned for higher values because the current exceeds the rated motor current during the stop process.

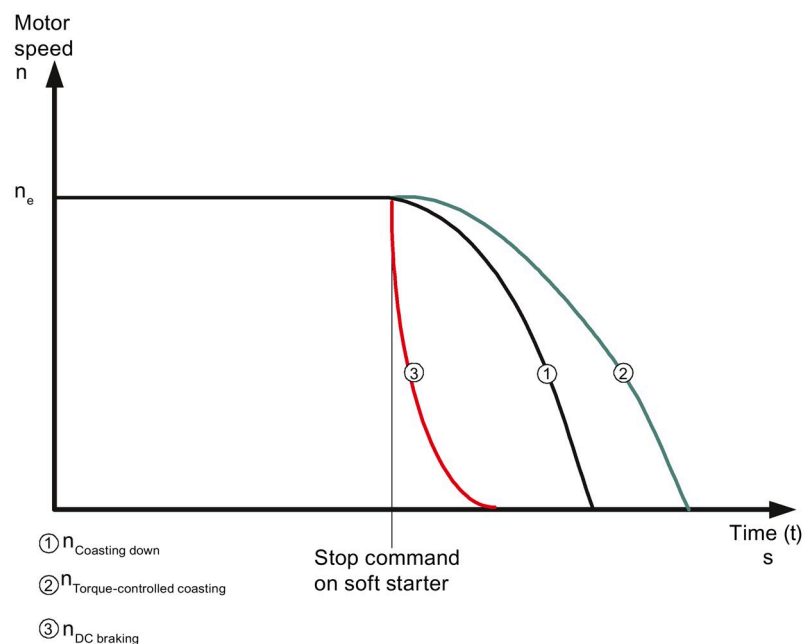

Figure 7-6 Coasting methods (general)

7.3.1 Coasting down

"Coasting down" means the power supplied to the motor via the soft starter is interrupted when the ON command is removed from the starter. The motor will coast down freely, driven only by the mass inertia (centrifugal mass) of the rotor and load. This is also referred to as a natural run-down. A large centrifugal mass means a longer stop time without load.

Typical applications for coasting down

Coasting down is used for loads that place no special demands on the stopping behavior, e.g. large fans.

7.3.2 Torque control and pump stop

In the case of "torque-controlled stop" and "pump stop", coasting down or the natural run-down of the load is decelerated. This function is set if there is a need to prevent the load from being stopped abruptly. Applications involving small mass inertia values or high counter-torques are typical examples.

For optimum torque control during the stopping procedure, enter the motor data of the motor connected to the soft starter in the selected parameter set using the "Setting" menu item.

Coast-down time and stopping torque

The "Coast-down time" parameter on the soft starter allows you to specify how long power should still be supplied to the motor after the ON command is removed. Within this coast-down time, the torque produced in the motor is continuously and linearly reduced to the set stopping torque, and the application is smoothly stopped.

Pump stop

In pump applications, so-called water hammers can occur if the drive is stopped abruptly without using pump stop. Water hammers are caused by the sudden stall and the accompanying pressure deviations in the pump. They cause noise and mechanical impacts on the piping system, as well as on any flaps and valves installed there.

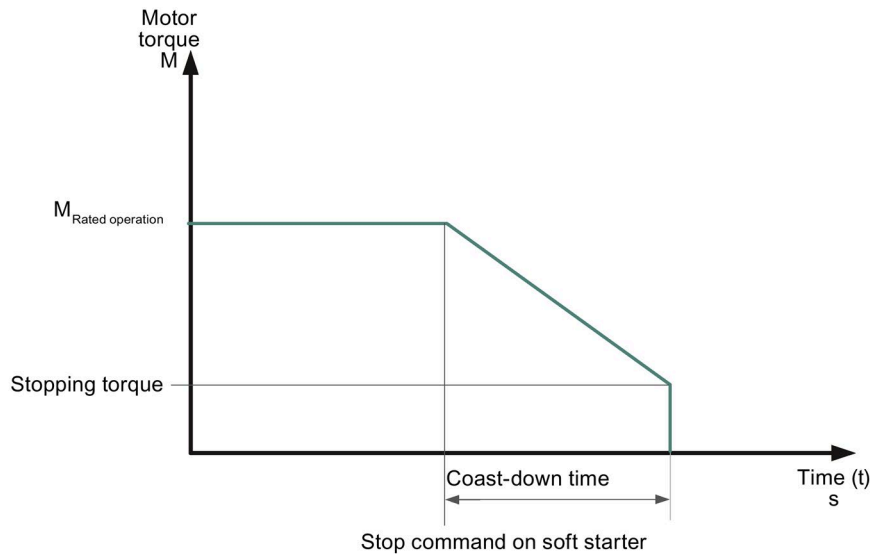

Figure 7-7 Soft stop/pump stop

Typical applications for soft stop/pump stop

Use soft stop/pump stop

- in pumps to prevent water hammer.
- in conveyor belts to prevent the conveyed materials from toppling.

⚠ CAUTION

Risk of property damage

For optimum motor protection, use the combination of electronic motor overload protection and evaluation of a temperature sensor installed in the motor.

7.3.3 DC braking/combined braking

In the case of DC braking or combined braking, coasting down or the natural run-down of the load is shortened.

The soft starter imposes a (pulsating) direct current in phases L1 and L3 on the motor stator. This current generates a permanent magnetic field in the stator. Since the rotor is still rotating due to its mass inertia, currents are induced in the short-circuited rotor winding that generate a DC braking torque.

Note

The DC braking/combined braking stopping function is not possible in inside-delta circuits.

Note

The pulsating direct current loads the system asymmetrically and the motor and the feeder must be designed for the higher current load during the stopping procedure. It may be necessary to overdimension the soft starter.

Note

Two braking variants are available:

Combined braking:

Use the combined braking function if applications with small mass inertias (centrifugal masses) are to be stopped ($J_{load} \leq J_{motor}$). The real coast-down time can vary during braking operations when the combined braking function is applied. Use the DC braking function if a uniformly long braking time is to be achieved.

DC braking:

Use the DC braking function if applications with small mass inertias (centrifugal masses) are to be stopped ($J_{load} \leq 5 \times J_{motor}$). An external braking contactor is required for the DC braking function.

 **CAUTION****Risk of property damage.**

For optimum motor protection, the combination of electronic motor overload protection and evaluation of a temperature sensor installed in the motor is recommended.

Combined braking coasting method

When the combined braking coasting method is chosen, the dynamic braking torque, DC braking torque and coast-down time can be set on the starter.

Dynamic braking torque

The dynamic braking torque determines the braking effect at the start of the braking process to reduce the speed of the motor. The braking process is then continued automatically using the DC braking function.

DC braking torque

The motor's brake force can be set with the amount of the DC braking torque. The dynamic braking torque must be increased if the motor is to accelerate again during DC braking.

Coast-down time

The coast-down time specifies the period during which the DC braking torque is to be generated on the motor. The chosen braking time should be long enough to bring the load to a standstill. To achieve an adequate braking effect down to standstill, the centrifugal mass (J) of the load should not exceed that of the motor. The length of the coast-down time should be chosen so that the motor comes to a standstill. Standstill detection does not take place in the soft starter and, if required, must be realized by means of external measures.

Note

The real coast-down time can vary during braking operations when the combined braking function is applied.

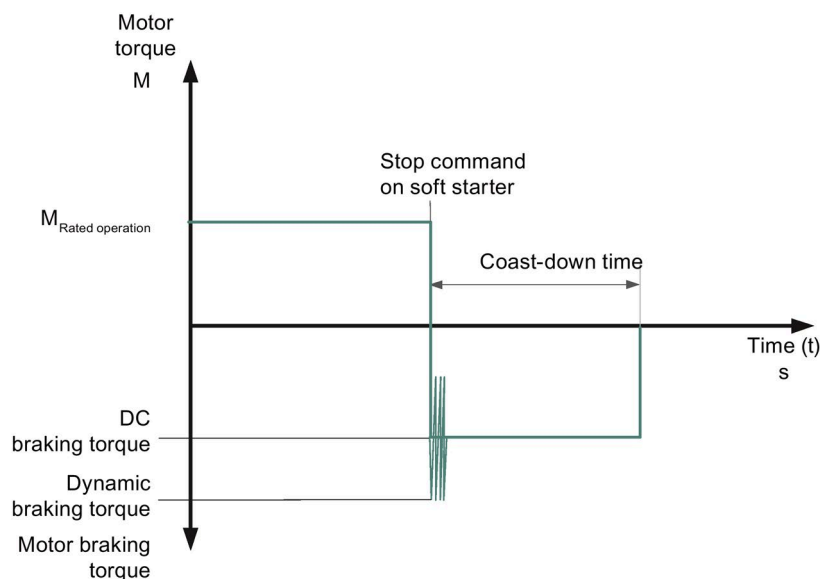

Figure 7-8 Combined braking

DC braking coasting method

When the DC braking function is selected, the coast-down time and DC braking torque can be set on the starter. In this braking variant, one output of the soft starter must be changed over to DC braking, through which an external braking contactor is controlled. You will find suggested circuits in chapter Typical circuit diagrams (Page 229).

The ideal parameters must be set on the machine under applicable load conditions.

DC braking torque

The motor's brake force can be set with the amount of the DC braking torque.

Coast-down time

The coast-down time specifies the period during which the DC braking torque is to be generated on the motor. The chosen braking time should be long enough to bring the load to a standstill.

To achieve an adequate braking effect down to standstill, the load's moment of inertia should not exceed a maximum of 5 times that of the motor. ($J_{load} \leq 5 \times J_{motor}$).

Standstill detection does not take place in the soft starter and, if required, must be realized by means of external measures.

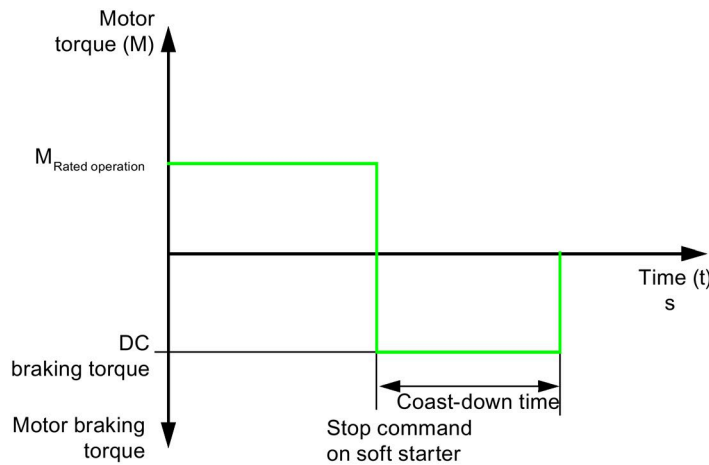

Figure 7-9 DC braking

Typical applications for DC braking

Use "DC braking" in lathes (e.g. for tool change) or circular saws.

7.4 Slow speed function

This function enables an induction motor to be operated temporarily in both directions at a lower speed than the rated speed.

The motor's rated speed n_{Motor} is determined by means of the line frequency (f) and the number of pole pairs (p) of the motor.

$$n_{\text{Motor}} = f \times \frac{60}{p}$$

A resulting slow speed frequency is stipulated for the motor by a specific thyristor control. However, it is necessary for this function that only a reduced torque can be generated in the motor. Due to possible heat rise of the motor, this function is not suitable for continuous operation.

The slow speed factor and the slow speed torque can be entered individually for both directions of rotation.

Slow speed factor

When the slow speed factor is set, the motor can be controlled with a lower speed ($n_{\text{slow speed}}$) than the rated speed either in or against the line phase direction.

$$n_{\text{Slow speed}} = \frac{n_{\text{Rated}}}{\text{Slow speed factor}}$$

Slow speed torque

The torque generated in the motor can be influenced with the slow speed torque. The maximum torque that can be generated depends on the selected slow speed. 100% slow speed torque can be equivalent to approximately 30% of the rated motor torque.

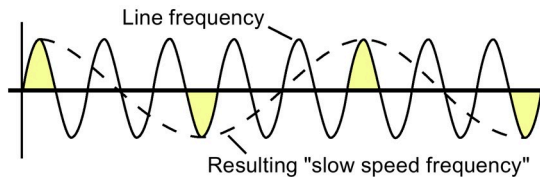

Figure 7-10 Slow speed function

Typical applications for the slow speed function

This function is suitable for applications **with a low counter-torque**, e.g. positioning of machine tools.

Note

In addition to the set parameters, motor-specific characteristics and the connected load influence the speed resulting from the slow speed function and the slow speed torque generated in the motor.

Note

For operation of the motor with the specified slow speed parameters, the "slow speed" function must be assigned to one control input, and the "Motor CW PS1/2/3" or "Motor CCW PS1/2/3" function must at the same time be assigned to the other. See also the circuit suggestion in chapter Typical circuit diagrams (Page 229).

Directions of rotation:

Right (CW): Rotation in line phase direction

Left (CCW): Rotation contrary to the line phase direction

Note

Due to the reduced motor speed and the related reduced self-cooling of the motor, this mode is not recommended for continuous operation.

CAUTION

Risk of property damage

For optimum motor protection, use the combination of electronic motor overload protection and evaluation of a temperature sensor installed in the motor.

7.5 Current limits for load monitoring

Low and high current limits can be set so that a message can be issued if they are exceeded or undershot.

Lower current limit

The lower current limit could be used, for example, to indicate tearing of a V belt and the associated no-load current of the motor or if the filter of the fan is clogged.

Upper current limit

The upper current limit can be used to determine increased power loss in the application, for example caused by bearing damage.

7.6 Motor protection functions

The motor overload protection function is implemented on the basis of the winding temperature. This indicates whether the motor is overloaded or is functioning in the normal operating range.

The winding temperature can either be calculated with the help of the integrated, electronic motor overload function or measured with a connected motor thermistor.

The two types of protection must be combined (= activated) to achieve full motor protection. This combination is recommended for optimum motor protection.

Motor overload protection

The current flow during motor operation is measured by measuring the current with transformers integrated in the soft starter. The temperature rise in the winding is calculated based on the rated operational current set for the motor.

A warning or trip is generated by the soft starter when the characteristic curve is reached, depending on the tripping class (CLASS setting) and protection parameters.

Tripping class (electronic overload protection)

The tripping class (CLASS) specifies the maximum time within which a protective device must trip from a cold state at 7.2 x the rated operational current (motor protection to IEC 60947). The tripping characteristics present this time as a function of the tripping current (refer to chapter Tripping characteristics (Page 297)).

You can set different CLASS characteristics according to the startup class.

Note

The rated data of the soft starters refers to normal starting (CLASS 10). The starters may need to be calculated with a size allowance for heavy-duty starting (> CLASS 10).

Current asymmetry limit value

Three-phase asynchronous motors respond to slight asymmetries in the line voltage with a higher asymmetrical current consumption. As a result, the temperature in the stator and rotor windings increases.

The asymmetry limit is a percentage value by which the motor current is allowed to deviate in each phase.

The maximum deviation from the mean value of the three phases is the reference value for evaluation.

Asymmetry is considered to exist if the deviation from the mean value is greater than 40 %.

Prewarning limit - remaining time for tripping

A message can be issued when the set prewarning limit time, referred to the calculated time up to tripping of the motor by the motor protection function, is reached.

Prewarning limit - motor heating

A message can be issued when the motor's set thermal prewarning limit is reached. Motor protection is activated at 100%.

Idle time

The idle time is a time defined for cooling of the motor model following an operational shutdown, i.e. not after overload trips.

After this time, the "thermal motor model" of the motor starter is set to 50 % when motor heat rise is still > 50 %, otherwise it is set to 0 %. Frequent starts (inching mode) are also possible as a result. These lead to tripping where motor protection in accordance with IEC 60947 is used, depending on the CLASS setting.

The following schematic diagram shows the cooling behavior with and without idle time.

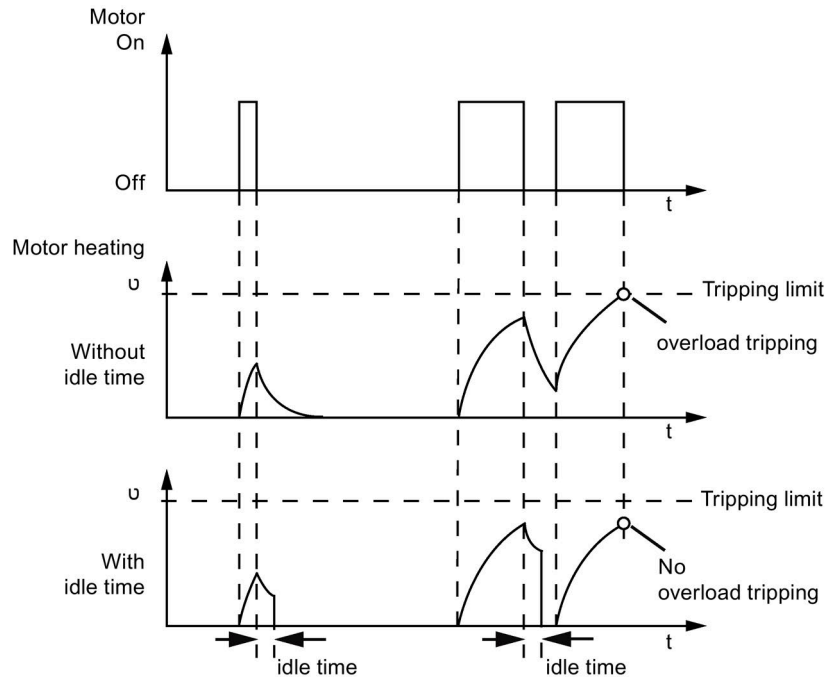

Figure 7-11 Idle time

The idle time can be set between 1 and 100 s.

⚠ CAUTION

Risk of property damage

Motor protection in accordance with IEC 60947 (CLASS 10A, 10, 15, 20, 30) is no longer provided if the idle time is changed (0 = deactivated). This means that there will be no system protection in such cases. Parallel protective measures are recommended.

⚠ CAUTION

Risk of property damage

The motor must be designed for such inching operation as otherwise permanent damage may arise due to overload.

Recovery time

A recovery time, during which the motor cools down and cannot be restarted, starts if the thermal motor model is tripped.

Protection against voltage failure

If protection against voltage failure is activated, and the control supply voltage fails during a trip, the current tripping state of the thermal motor model and the current recovery time are stored in the soft starter. When the control supply voltage is restored, the current tripping state of the thermal motor model prior to the power failure is likewise automatically restored.

Temperature sensor

This motor protection function measures the motor's stator winding temperature directly with the help of a sensor installed in the motor, in other words the motor must have a sensor wound into the stator winding.

You can choose between two different sensor types for the evaluation.

1. PTC thermistors Type A ("type A sensors")
2. Thermoclick sensors

The wiring and the sensors are checked for wire breakage and short-circuits.

Note

If the soft starter is switched off via a motor protection or inherent device protection tripping, the action cannot be acknowledged using the "Trip Reset" function until the displayed cooling time has expired.

7.7 Intrinsic device protection

7.7.1 Intrinsic device protection

The soft starter has integrated intrinsic device protection that prevents thermal overloading of the thyristors.

This is realized on the one hand by current measurement using transformers in the three phases and additionally by temperature measurement using thermal sensors on the thyristor heat sink.

A message is generated on the soft starter if a permanently set warning threshold is exceeded. If the internal permanently set switch-off value is exceeded, the soft starter will switch off automatically.

After tripping, a fixed 30 s recovery time must be observed before the starter can be started again.

If protection against voltage failure is activated, and the control supply voltage fails during a trip, the current tripping state of the thermal motor model and the current recovery time are stored in the soft starter. When the control supply voltage is restored, the current tripping state of the thermal intrinsic device protection prior to the power failure are likewise automatically restored.

SITOR semiconductor fuses must be connected upstream to protect the thyristors against short-circuits (e.g. in case of cable damage or an interturn fault in the motor). You will find applicable selection tables in chapter Feeder component layout (standard circuit) (Page 286) and in chapter Feeder component layout (inside-delta circuit) (Page 291).

Note

If the soft starter is switched off via a motor protection or inherent device protection tripping, the action cannot be acknowledged using the "Trip Reset" function until the displayed cooling time has expired.

Diagnostics and messages

8.1 Diagnostics and messages

8.1.1 Status messages

Message	Cause/solution
Check voltage	The main voltage is not yet applied.
Check the line phases	Option 1: Main voltage is applied, but the motor is not yet connected or is not yet connected correctly. Option 2: The motor is connected correctly, but there is no phase voltage.
Ready to start	Device is ready (main voltage is applied and motor is connected correctly). The motor starts as soon as a start command is issued.
Starting active	Motor is started with the selected startup mode.
Motor running	Device is in bypass mode (bypass contactor). Start-up completed.
Coast down active	Motor is stopped with the selected coasting method.
Motor cooling time active (for devices with product version < *E06*)	After an overload trip of the thermal motor model, starting of the motor is not possible for a certain period of time (parameter: recovery time), to ensure that the motor can cool down.
Switching element cooling time (for devices with product version < *E06*)	After the device's intrinsic protection mechanism has tripped because of an overload, the motor cannot be started for 30 s to allow the device to cool down.
Emergency start active	The emergency start function is activated.
Quick stop active	The quick stop function is activated.

8.1.2 Warnings and group faults

- ① Warning
- ② Fault without restart
- ③ Fault with restart

Message	①	②	③	Cause/solution
No supply voltage		x		<p>1. Start command has been issued although the main voltage is not yet applied.</p> <p>Remedy: Switch on the supply voltage.</p> <p>2. If the message occurs in the bypass mode, it may have been generated erroneously by a too frequently generated "Prewarning limit - motor heating", "Remaining time for tripping" or "I_e limit exceeded/undershot" warning (can also be traced via the entries in the logbook/events).</p> <p>Remedy: See description of applicable messages</p> <p>3. Main voltage is removed simultaneously with the ON command, although run down (not "Coasting down") is parameterized.</p> <p>Remedy: Activate line contactor by means of output parameterized to ON time or parameterize "Coasting down".</p>
<p>Incorrect starting conditions (for devices with product version < *E04*)</p> <p>Phase angle control faults (for devices with product version ≥ *E04*)</p>		x		<p>1. Fault occurs without motor starting.</p> <p>Cause:</p> <ul style="list-style-type: none"> - Motor has not been connected correctly. - Inside-delta circuit is wrongly configured. - There is a ground fault. <p>Remedy: Check and correct wiring (see circuit suggestions for inside-delta circuit).</p> <p>2. Fault occurs during starting.</p> <p>Cause:</p> <ul style="list-style-type: none"> - Chosen starting voltage too high - Breakaway pulse (wrongly) set: Motor starting becomes unstable <p>(set the breakaway pulse only when it is really required. In the case of pumps, for example, a breakaway pulse often leads to misfiring.) If there is an idle time < 5 s since the last start, the 3RW44 starts with a higher starting voltage. In combination with a set breakaway pulse, this can lead to "incorrect starting conditions".</p> <p>Remedy: Adjust parameters or extend idle time.</p>

Message	①	②	③	Cause/solution
Phase failure L1		x		<p>Option 1: Phase L1 is missing or fails or drops while the motor is running. Tripped as a result of a dip in the permissible rated operational voltage > 15 % for > 100 ms during the startup process or > 200 ms in bypass mode. Remedy: Connect L1 or rectify the voltage dip.</p> <p>Option 2: The motor that is connected is too small and the fault occurs as soon as it is switched to bypass mode. Remedy: Set the correct rated operational current for the connected motor or set it to the minimum value (if the motor current is less than 10 % of the set I_e, the motor cannot be operated with this starter).</p> <p>Option 3: Starter used in IT system with ground-fault monitoring: 3RW44, product version < *E06* and the PROFIBUS DP communication module must not be used in this network configuration. Remedy: Replace starter with 3RW44, product version \geq *E07*. Here, use in combination with the PROFIBUS DP communication module is admissible. However, the phase voltage values (UL-N) and phase-to-phase voltage values (UL-L) may be displayed incorrectly on the measured value display of the 3RW44.</p>
Phase failure L2		x		<p>Option 1: Phase L2 is missing or fails or drops while the motor is running. Tripped as a result of a dip in the permissible rated operational voltage > 15 % for > 100 ms during the startup process or > 200 ms in bypass mode. Remedy: Connect L2 or rectify the voltage dip.</p> <p>Option 2: A motor that is not powerful enough is connected and the fault occurs as soon as a switchover is made to bypass mode. Remedy: Set the correct rated operational current for the connected motor or set it to the minimum value (if the motor current is less than 10 % of the set I_e, the motor cannot be operated with this starter).</p> <p>Option 3: Starter used in IT system with ground-fault monitoring 3RW44, product version < *E06* and the PROFIBUS DP communication module must not be used in this network configuration. Remedy: Replace starter with 3RW44, product version \geq *E07*. Here, use in combination with the PROFIBUS DP communication module is admissible. However, the phase voltage values (UL-N) and phase-to-phase voltage values (UL-L) may be displayed incorrectly on the measured value display of the 3RW44.</p>

8.1 Diagnosics and messages

Message	①	②	③	Cause/solution
Phase failure L3		x		<p>Option 1: Phase L3 is missing or fails/collapses when the motor is in operation. Tripped as a result of a dip in the permissible rated operational voltage > 15 % for > 100 ms during the startup process or > 200 ms in bypass mode. Remedy: Connect L3 or rectify the voltage dip.</p> <p>Option 2: A motor that is not powerful enough is connected and the fault occurs as soon as a switchover is made to bypass mode. Remedy: Set the correct rated operational current for the connected motor or set it to the minimum value (if the motor current is less than 10 % of the set I_e, the motor cannot be operated with this starter).</p> <p>Option 3: Starter used in IT system with ground-fault monitoring 3RW44, product version < *E06* and the PROFIBUS DP communication module must not be used in this network configuration. Remedy: Replace starter with 3RW44, product version \geq *E07*. Here, use in combination with the PROFIBUS DP communication module is admissible. However, the phase voltage values (UL-N) and phase-to-phase voltage values (UL-L) may be displayed incorrectly on the measured value display of the 3RW44.</p>
Missing load phase T1		x		<p>Motor phase T1 is not connected. Remedy: Connect the motor properly.</p>
Missing load phase T2		x		<p>Motor phase T2 is not connected. Remedy: Connect the motor properly.</p>
Missing load phase T3		x		<p>Motor phase T3 is not connected. Remedy: Connect the motor properly.</p>
Supply voltage below 75 %		x		<p>Control supply voltage is less than 75% of the required rated voltage for more than 100 ms (voltage failure, voltage dip, incorrect control supply voltage). Remedy: Check the control supply voltage.</p>
Supply voltage below 85%		x		<p>Control supply voltage is less than 85 % of the required rated voltage for more than 2 s (voltage failure, voltage dip). Remedy: Check the control supply voltage.</p>
Supply voltage above 110%		x		<p>Control supply voltage is more than 110 % of the required rated voltage for more than 2 s (voltage peaks, incorrect control supply voltage). Remedy: Check the control supply voltage.</p>
Current unbalance exceeded	x	x		<p>The phase currents are asymmetrical (unbalanced load). Message is output when the asymmetry is greater than the set limit (parameter: Current asymmetry limit value). Remedy: Check the load or modify the parameter value.</p>

Message	①	②	③	Cause/solution
Thermal motor model overload	x	x	x	The thermal motor model has tripped. After an overload trip, restarting is inhibited until the recovery time has elapsed. Remedy in the event of unwanted tripping: <ul style="list-style-type: none"> • Check whether the motor's rated operational current I_e is set correctly, or • Change the CLASS setting, or • Possibly reduce the switching frequency, or • Deactivate the motor protection (CLASS OFF)
Prewarning limit - motor heating	x			Motor heating is greater than the set parameter value: Prewarning limit - motor heating. The thermal motor model approaches an overload trip depending on the set value. For heavy starting and set values of tripping class \geq CLASS 20, we recommend increasing the "Prewarning limit motor heating" parameter to 95 %.
Remaining time for tripping undershot	x			Time up to overload trip of the thermal motor model is shorter than the set "Prewarning limit - remaining time for tripping" parameter. In the case of heavy starting and set values of tripping class \geq CLASS 20, we recommend setting the "Prewarning limit - remaining time for tripping" parameter value to 0 s (deactivated).
Line overvoltage (for devices with product version < *E04*) Line voltage too high (for devices with product version \geq *E04*)		x		Applied 3-phase line voltage is not suitable for the device or prolonged voltage peaks arise. Tripping is caused by exceeding of the permissible rated control supply voltage of >10 % >500 ms. As from product version *E02*, the internal threshold for tripping has been increased to >18 % >2000 ms. Remedy: Apply the correct voltage.
Current measuring range overshoot		x		1. A very high current has occurred (above the measuring range of the current transformers integrated in the soft starter). This can occur in the event of: direct-on-line starting, breakaway pulse or combined braking. Remedy: In the case of the "Voltage ramp" start type, extend the set ramp time and reduce the breakaway voltage or the braking torque. The soft starter is possibly dimensioned too small for the motor. 2. If the message occurs during starting, it may have been generated erroneously by a too-frequently generated "Prewarning limit - motor heating", "Remaining time for tripping" or " I_e limit exceeded/undershot" warning (can also be traced via the entries in the logbook/events). Remedy: See description of applicable messages.
Trip - motor blocked (devices with product version <*E07* only)		x		A very high current suddenly arises in bypass mode, e.g. if the motor blocks ($I > 4 \times I_{eMotor}$ over 100 ms). Remedy: Check the motor.
Current range exceeded		x		More than 6 times the device's rated operational current flowed for a prolonged period. Remedy: Activate current limiting or check dimensioning (device and motor).

8.1 Diagnostics and messages

Message	①	②	③	Cause/solution
Power unit overheated		x	x	Overload trip of the thermal model for the power unit Remedy: Wait until the device has cooled down again, possibly set lower current limiting for starting, or reduce the switching frequency (too many consecutive starts). Check whether the motor is blocked or whether the ambient temperature in the soft starter's environment is too high (derating as from 40 °C; see chapter Technical data (Page 268)).
Power unit overtemperature	x			Temperature of the thermal model for the power unit is above the allowed continuous operating temperature. Remedy: Check the motor's operational current or check whether the ambient temperature in the soft starter's environment is too high (derating as from 40 °C; see chapter Technical data (Page 268)).
Temperature sensor short-circuit	x	x	x	Temperature sensor at terminals T1/T2 has short-circuited. Remedy: Check the temperature sensor.
Temperature sensor wire break	x	x	x	Temperature sensor at terminals T1/T2 is defective, a cable is not connected or no sensor is connected. Remedy: Check the temperature sensor or if no sensor is connected: deactivate the temperature sensor.
Temperature sensor overload	x	x	x	Temperature sensor at terminals T1/T2 has tripped. The motor is overheated. Remedy: Wait until the motor has cooled down and check the motor if necessary.
Maximum starting time exceeded		x		The set maximum starting time is shorter than the motor's actual ramp-up time. Remedy: Extend the "max. starting time" parameter, increase the current limiting value or check the load connected to the motor to determine whether there is a mechanical defect.
I _e limit value exceeded/undershot	x	x		Set current limit has been exceeded or undershot, e.g. due to a clogged fan filter or by the motor stalling. Remedy: Check the cause of current limit violation on the motor/load or adjust the limits according to the existing load conditions.
Ground fault detected	x	x		One phase is connected to ground (only possible in bypass mode) Remedy: Check connections and wiring.
Manual mode local connection break	x			The connection to the PC has been interrupted (if control via PC) or no key has been pressed (if the motor is key-controlled) for a prolonged time (see Settings > Display > Activity monitoring time in chapter Selecting display settings (Page 102)). Control is handed over to the inputs if these have requested control priority. Remedy: Connect the PC again or increase the activity monitoring time and press a key at regular intervals.

Message	①	②	③	Cause/solution
Impermissible I _e /CLASS setting		x		<p>The rated operational current I_e set for the motor (chapter Entering the motor data (Page 66)) in at least one of the three parameter sets exceeds the associated, maximum permissible setting current referred to the selected CLASS setting (chapter Selecting motor protection settings (Page 99)). In the case of devices with product version ≥ *E07*, the corresponding parameter set (PS) in which the incorrect value is to be found is displayed.</p> <p>For the maximum permissible settings, see chapter Technical data (Page 268).</p> <p>If the soft starter is connected in an inside-delta circuit, the motor feeder may have been incorrectly wired (chapter 3RW44 in an inside-delta circuit (Page 234)); as a result, the "Status display/Connection type" menu item (chapter Status display (Page 114)) contains "Unkn./Fault".</p> <p>Remedy: Check the rated operational current set for the motor in all three parameter sets, select a lower CLASS setting, or calculate the soft starter with a size allowance. In the case of an inside-delta circuit, check that the wiring of the motor feeder corresponds to the specified circuit diagrams.</p> <p>As long as the motor is not activated, it is only a status message. However, the message becomes a fault without restart if a start command is issued.</p>
No external starting parameters received (devices with product version ≥ *E06*)		x		<p>Occurs only during operation with PROFIBUS DP. Incorrect or impermissible parameter values have been sent by the PLC.</p> <p>Remedy: The Soft Starter ES software can be used to read the incorrect parameter and to change it to a permissible value.</p>
PIO error (devices with product version ≥ *E06*)			x	<p>PIO error (faulty process image of the outputs) appears</p> <ul style="list-style-type: none"> • If Motor CW and Motor CCW have been selected simultaneously (cause 1) or • If Parameter set 4 has been selected via the PLC (cause 2). <p>Remedy:</p> <ul style="list-style-type: none"> • Automatically reset if Motor CW and Motor CCW are deactivated again (in response to cause 1) or • If a valid parameter set (PS 1 - 3) is set again (in response to cause 2).
Bypass element protective tripping (devices with product version ≥ *E07*)		x		<p>A very high current occurs in bypass mode. The tripping operation depends on the duration of the current and strength of the current. Fault can only be reset after 30 s (for cooling down).</p> <p>Remedy: Check the motor and check soft starter dimensioning.</p>

8.1.3 Device fault

Message	Cause/solution
Switching element defective (for devices with product version ≥ *E04*)	At least one bypass element has welded and/or at least one thyristor has fused. This message is generated when the control supply voltage is applied and current flow is being measured (via the soft starter) when no start command has been issued. ¹⁾ Remedy: Contact your SIEMENS partner or create a support request (see Chapter Support Request (Page 10)).
Contact 1 failed	Thyristor in phase L1 failed (This message is issued when the start command is issued.) ¹⁾ Remedy: Contact your SIEMENS partner or create a support request (see Chapter Support Request (Page 10)).
Contact 2 failed	Thyristor in phase L2 failed (This message is issued when the start command is issued.) ¹⁾ Remedy: Contact your SIEMENS partner or create a support request (see Chapter Support Request (Page 10)).
Contact 3 failed	Thyristor in phase L3 failed (This message is issued when the start command is issued.) ¹⁾ Remedy: Contact your SIEMENS partner or create a support request (see Chapter Support Request (Page 10)).
Flash memory error	The device memory is faulty. Remedy: Contact your SIEMENS partner or create a support request (see Chapter Support Request (Page 10)).
Device not named	Device not named, still has to receive naming data. Remedy: Contact your SIEMENS partner or create a support request (see Chapter Support Request (Page 10)).
Incorrect name version	The naming and firmware versions do not match. Remedy: Contact your SIEMENS partner or create a support request (see Chapter Support Request (Page 10)).
Bypass element defective	The bypass contactor is welded or defective. Remedy: Contact your SIEMENS partner or create a support request (see Chapter Support Request (Page 10)).

Message	Cause/solution
Heatsink temperature sensor wire break	<p>Option 1: The temperature sensor on the heatsink of the starter is not connected or defective.</p> <p>Option 2: 3RW4465 and 3RW4466 may have a defective fan on the front of the starter.</p> <p>Remedy: Only in the case of 3RW4465 and 3RW4466: After about 30 to 60 minutes cooling time, try to rectify the fault by switching the control supply voltage off and then on again. If this was successful, check whether the fan on the front of the soft starter is running when the start command is issued. If not, it may be necessary to replace the fan. (The fan on the front of the starter and also the fans on the bottom of the unit both be running simultaneously in fault-free operation).</p> <p>For all 3RW44 starters: If it was not possible to reset the fault message by switching the control supply voltage off and on again, contact your SIEMENS partner or create a support request (see Chapter Support Request (Page 10)).</p>
Heatsink sensor short-circuit	<p>The temperature sensor on the heatsink of the starter is not connected or defective.</p> <p>Remedy: Contact your SIEMENS partner or create a support request (see Chapter Support Request (Page 10)).</p>

1) Possible ohmic value for a defective thyristor: <2 kOhm (L-T).

Note

In certain circumstances, some fault messages may be incorrect (e.g. phase failure L1 although L2 is missing).

Note

When using the 3RW44 soft starter in an IT system with ground fault monitoring: 3RW44, product version ≤ *E06* and the PROFIBUS DP communication module must not be used in this network configuration. 3RW44 soft starters from product version *E07* onwards can be used in combination with the PROFIBUS DP communication module. However, the phase voltage values (UL-N) and phase-to-phase voltage values (UL-L) may be displayed incorrectly on the measured value display of the 3RW44.

Note

PROFINET communication modules can only be used with a product version of *E12* or later.

PROFIBUS DP communication module

9.1 Introduction

Using the communication module (PROFIBUS or PROFINET), the 3RW44 soft starter and its all its functionality can be integrated in the automation level.

You will find the manual for the PROFINET communication module on the Internet (<https://support.industry.siemens.com/cs/ww/en/view/85225796>).

Requirements

- You have configured an infeed module with integrated S7 station, e.g. with CPU315-2 DP.
- STEP 7 (V 5.1 or higher + hotfix 2) is fully installed on your PC or programming device.
- You are proficient in STEP 7.

NOTICE

The PROFIBUS DP communication module can only be operated on 3RW44 devices with product version "E06" or higher, implemented on devices from production date 130601 onwards.

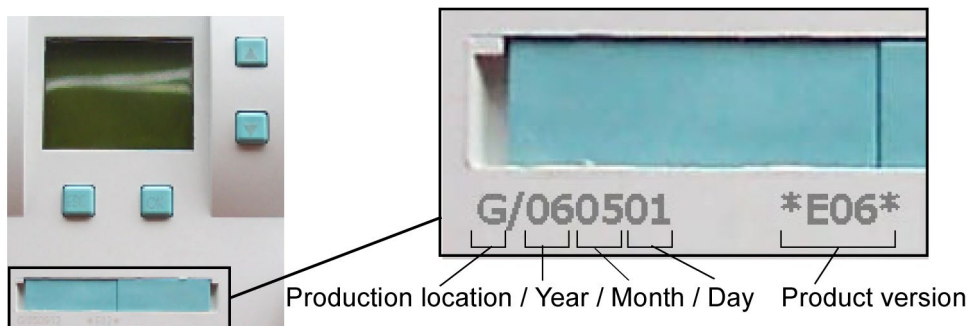

NOTICE

IT systems with ground-fault monitoring:

3RW44, product version \leq *E06* and the PROFIBUS DP communication module must not be used in this network configuration. 3RW44 soft starters from product version *E07* onwards can be used in combination with the communication module. However, the phase voltage values (UL-N) and phase-to-phase voltage values (UL-L) may be displayed incorrectly on the measured value display of the 3RW44.

NOTICE

For 3RW44 PROFIBUS DP communication module with product version < *E03*:
use of the 3RW44 with PROFIBUS on redundant controllers and Y-Link:
The 3RW44 acts like a DPV0 slave on Y-link. Parameter assignment is only possible via the GSD file and only cyclic data is transmitted, no data sets or alarms.

For 3RW44 PROFIBUS DP communication module, product version *E04* or higher:
As from this version, DPV1 operation (read/write data sets and alarms) is also possible downstream from a Y-link.

Further documentation on the subject of PROFIBUS DP

SIRIUS PROFIBUS communication module for 3RW44 soft starter
(<https://support.industry.siemens.com/cs/ww/en/view/23071380>) operating instructions with the article number 3ZX1012-0RW44-0KA0.

Further documentation on the subject of PROFINET IO

SIRIUS PROFINET communication module for 3RW44 soft starter
(<https://support.industry.siemens.com/cs/ww/en/view/85261694>) operating instructions with the article number 3ZX1012-0RW40-0NA1.

9.1.1 Definitions

S7 slave

An S7 slave is a slave that is fully integrated into STEP 7. It is embedded via OM Soft Starter ES Professional. It supports the S7 model (diagnostic interrupts).

Writing data

Writing data means that data is transmitted to the soft starter.

Reading data

Reading data means that data is transmitted from the soft starter.

GSD

Device master data (GSD) contains DP slave descriptions in a standardized format. The use of device master data simplifies the configuration of the DP master and the DP slave. See Chapter Configuring with the GSD file (Page 173).

9.2 Data transfer

9.2.1 Options for data transfer

The following figure shows the data transfer options:

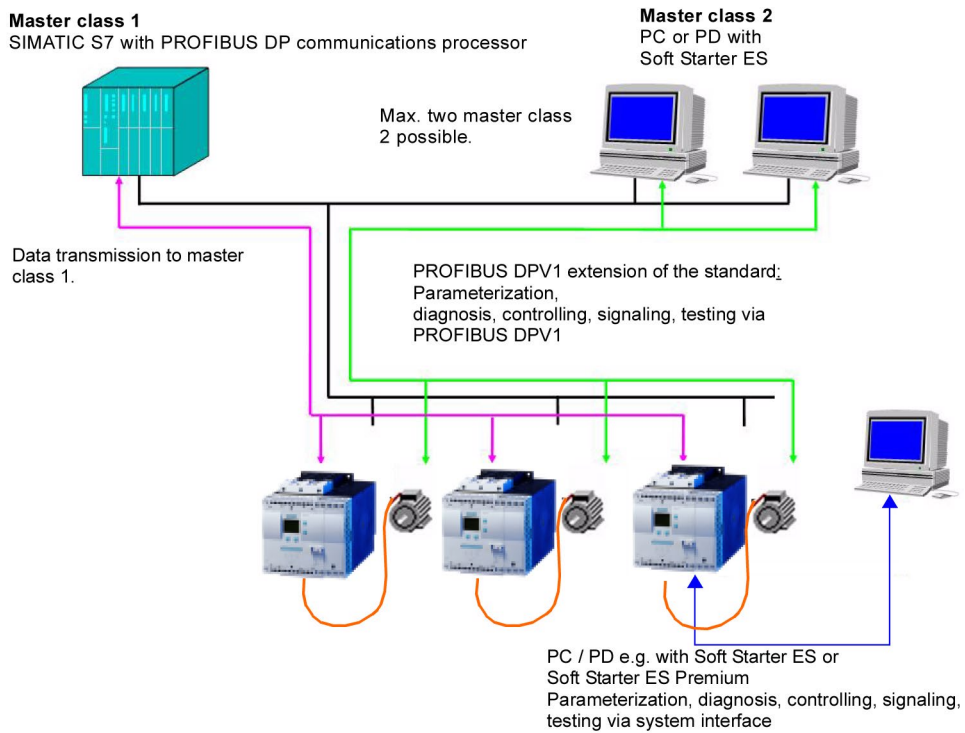

Figure 9-1 Options for data transfer

9.2.2 Communication principle

The following figure shows the communication principle and the way data is transmitted depending on the master and slave operating modes:

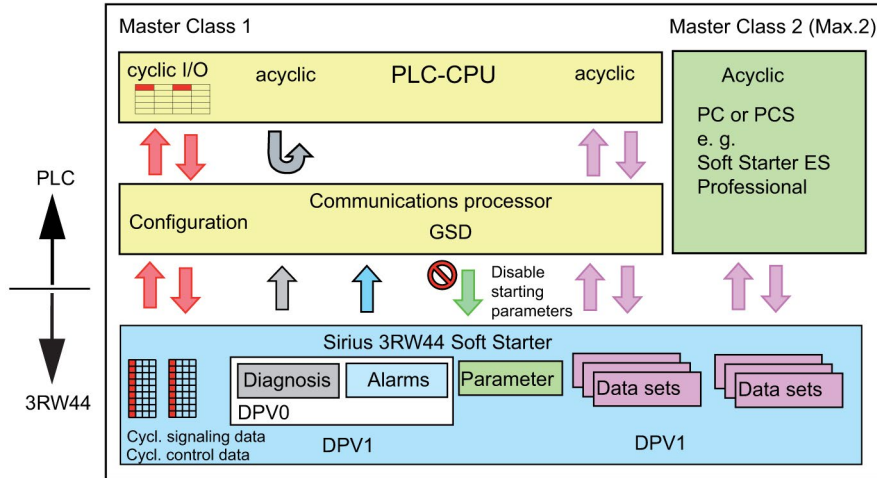

Figure 9-2 Communication principle

9.3 Installing the PROFIBUS DP communication module

⚠ WARNING
Hazardous voltage!
Can cause electric shock and burns. Turn off and lock out all power supplying the system and device before working on the device.

Read the information in the SIRIUS PROFIBUS communication module for 3RW44 soft starter (<https://support.industry.siemens.com/cs/ww/en/view/23071380>) operating instructions with the article number 3ZX1012-0RW44-0KA0.

9.3.1 Inserting the PROFIBUS DP communication module (fieldbus interface)

NOTICE
Risk of property damage.
Before inserting the PROFIBUS DP communication module, disconnect the power to the 3RW44 soft starter.

Note

The PROFIBUS DP communication module can only be operated on 3RW44 devices with product version "E06" or higher, implemented on devices from production date 060501 onwards.

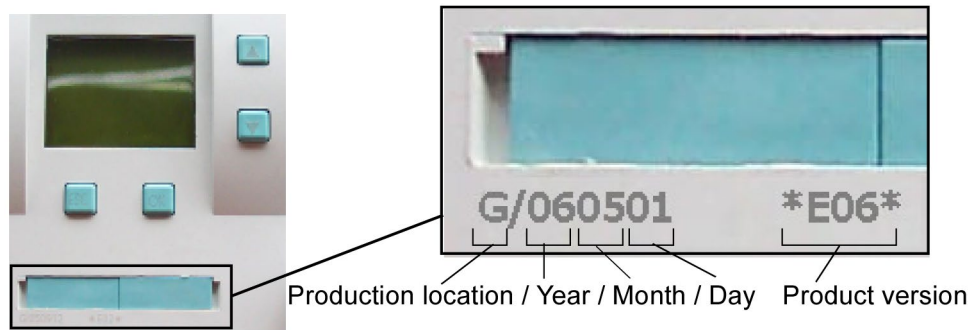

Proceed as follows:

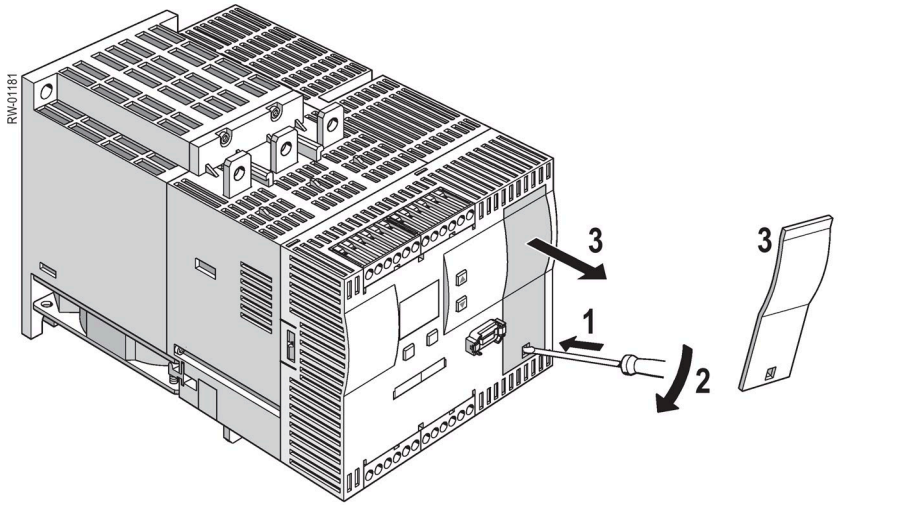
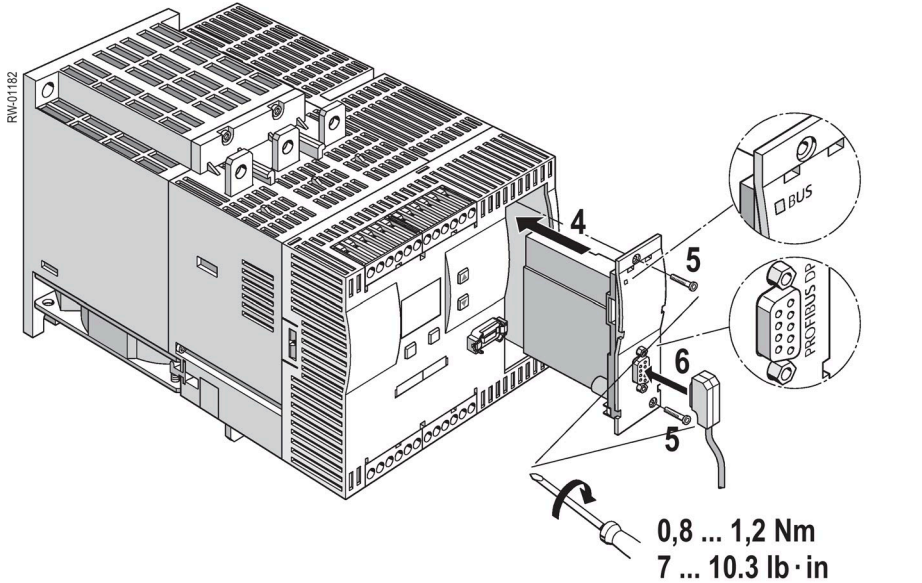
Step	Description
	<p>Slide a small screwdriver into the opening of the cover of the 3RW44 soft starter (1). Gently press the screwdriver downwards (2) and remove the cover (3).</p>
 <p>0,8 ... 1,2 Nm 7 ... 10.3 lb·in</p>	<p>Insert the PROFIBUS DP communication module into the device (4).</p> <p>Screw the PROFIBUS DP communication module into place using screws included in the scope of supply (5).</p> <p>Insert the PROFIBUS DP connecting cable into the socket of the communication module (6). Screw the PROFIBUS connecting cable firmly into place.</p> <p>Switch on the power supply. The "BUS" LED flashes yellow. This means that the communication module has been inserted correctly, but has not yet been activated.</p>

9.4 Activating the PROFIBUS DP communication module (fieldbus interface) and setting the station address

9.4.1 Introduction

Activate the PROFIBUS DP communication module ("Fieldbus" device function) and set the station address either via the display or the device interface using the "Soft Starter ES Premium" or "Soft Starter ES + SP1" software.

Note

After the communication module has been activated, the default control priority automatically switches from the inputs to the PROFIBUS DP communication module.
If an input with the "Manual mode local" function is active, the control priority does not change (refer to chapter Parameterizing the inputs (Page 94)).

The soft starters are pre-set to station address 126 as the factory default.

9.4.2 Activating the PROFIBUS DP communication module via the display, setting the station address and saving the settings

1. During first commissioning of the soft starter, you must run through the Quick Start menu (refer to chapter Switching on for the first time (Page 55)). See also SIRIUS 3RW442/443/444/445/446 soft starter operating instructions (<https://support.industry.siemens.com/cs/ww/en/view/21189750>) (article number: 3ZX1012-0RW44-0AA0).
2. Press the designated button on the device.

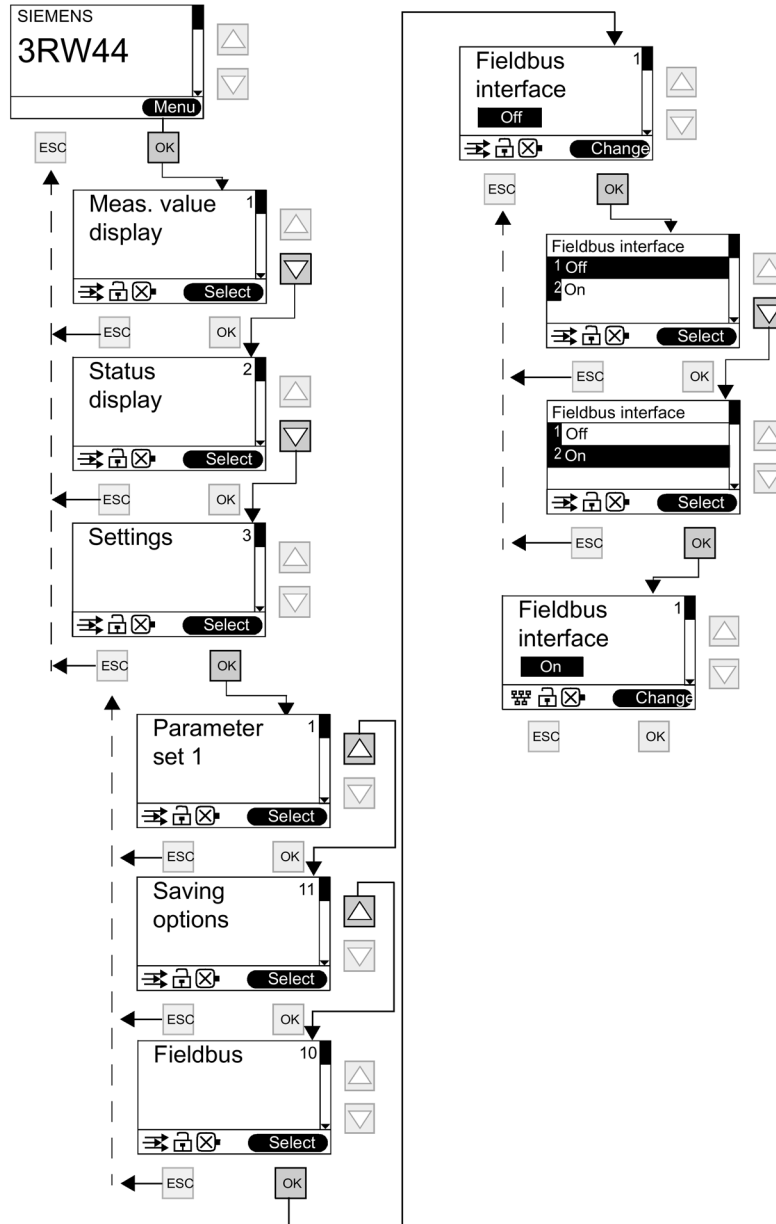

3. The "BUS" LED flashes red.

- The PROFIBUS DP communication module has been successfully activated if the PROFIBUS icon appears on the display.
The next step is to assign the desired station address for the 3RW44 as a PROFIBUS slave.
In this example, the station address "23" has been selected.

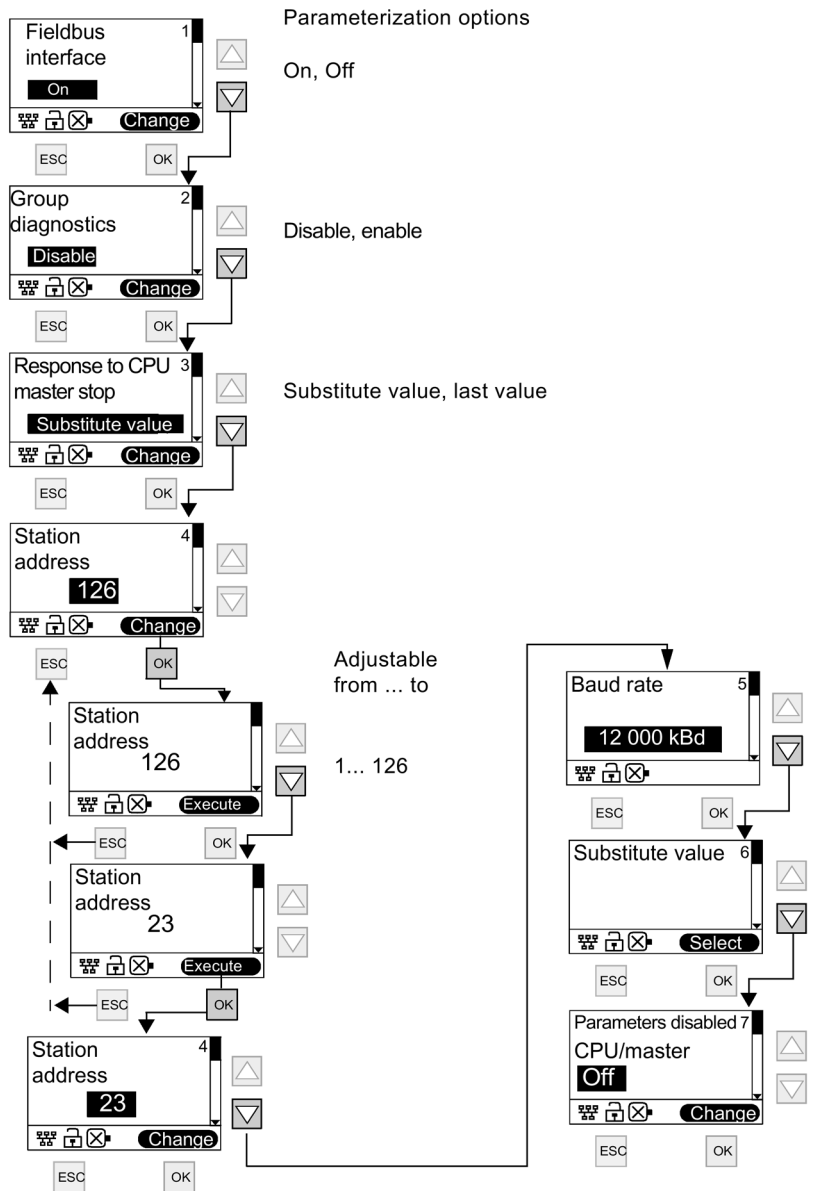

Note

If the "Parameters disabled CPU/Master" parameter is set to "Off" (factory setting), the parameters set on the soft starter will be overwritten with the values stored in the GSD file or in the OM when the bus is started. If this is not desired, the parameter must be set to "On".

5. In order to permanently save the settings, proceed as follows:

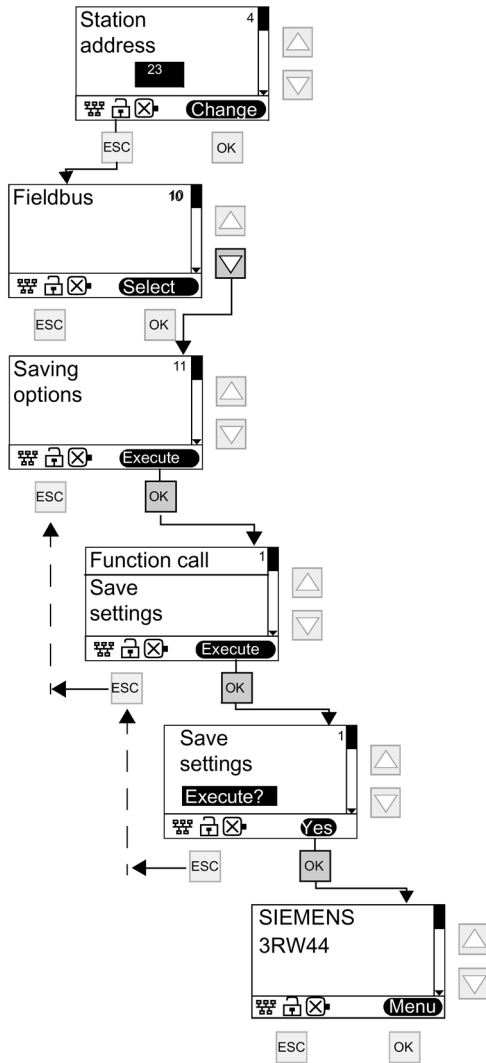

Note

If the "Parameters disabled CPU/Master" parameter is set to "Off" (factory setting) in the "Fieldbus" menu, the parameters set on the soft starter will be overwritten with the values stored in the GSD file or in the OM when the bus is started. If this is not desired, the parameter must be set to "On".

9.4.3 Activating the PROFIBUS DP communication module (fieldbus interface) and setting the station address via the device interface using the "Soft Starter ES Premium" or the "Soft Starter ES Smart + SP1" software

Perform the following steps in order to activate the communication module:

1. Connect the 3RW44 soft starter via the interface cable to a PC on which the "Soft Starter ES Professional" or "Soft Starter ES Smart + Service Pack 1" software is installed.
2. Start the "Soft Starter ES Professional" or "Soft Starter ES Smart + Service Pack 1" software.
3. Select "Switching device > Open online" in the menu.
4. Select the "Local device interface" option in the "Open online" dialog and select the desired COM port under "interface".
5. Click "OK".
6. Select "Device configuration" on the left side of the window.
7. Select the "Fieldbus interface" check box on the right side of the window.

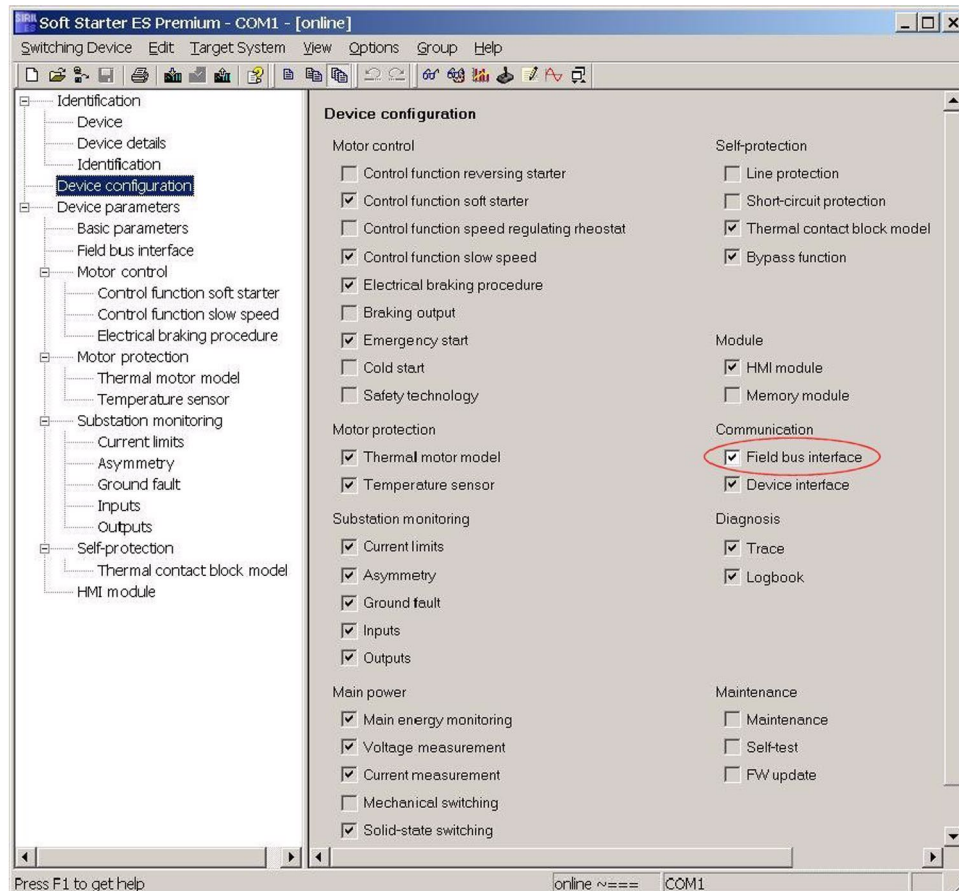

9.4 Activating the PROFIBUS DP communication module (fieldbus interface) and setting the station address

8. Select "Device parameters > Fieldbus" on the left side of the window.
9. Select the "Load to switching device" icon in the toolbar.

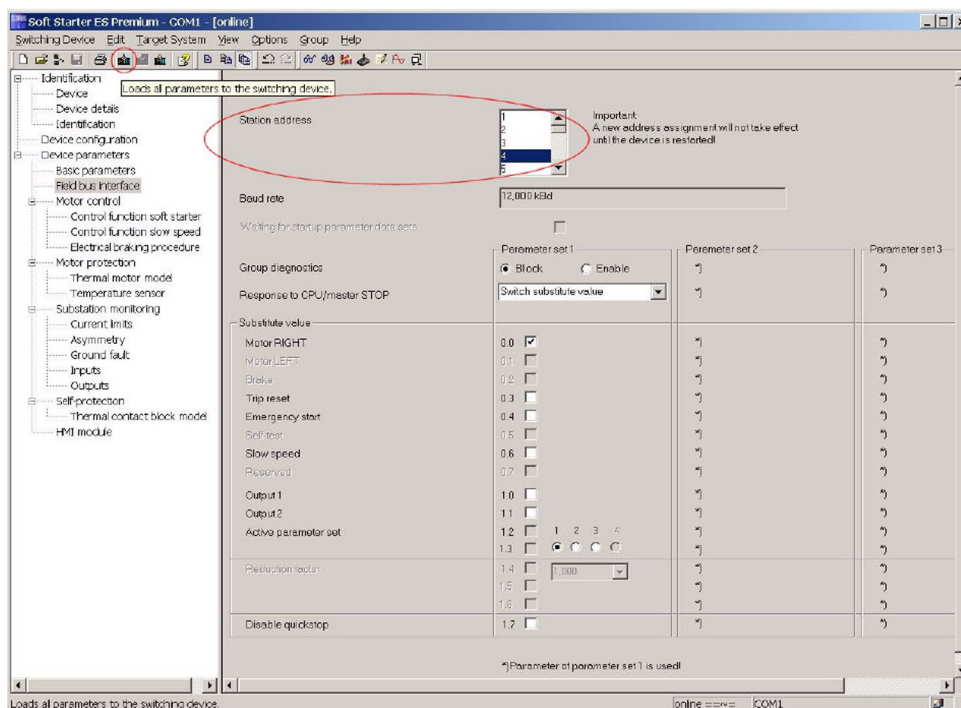

10. Acknowledge the changed station address with "OK".
11. Acknowledge activation of the PROFIBUS DP communication module with "OK".
The PROFIBUS DP communication module is activated.
12. If the "BUS" LED on the communication module flashes red and the PROFIBUS icon  appears in the display, the communication module has been successfully activated.

Note

The soft starter only reads the station address automatically and saves it permanently when the soft starter's supply voltage is activated (see chapter Flow diagram: PROFIBUS DP starting the soft starter (Page 180)) or when the "Restart" command is issued.

9.5 Configuring soft starters

9.5.1 Introduction

This section refers to the configuring and parameterization of soft starters

- Configuring: systematic arrangement of individual soft starters (configuration).
- Parameterization: assigning parameters using the configuring software.
You can find additional information on parameters in chapter Data formats and data sets (Page 192).

STEP 7

- The "Diagnose hardware" function is possible with STEP 7 V5.1, correction K5.1.2.0 or higher.
- Reading back the configuration is not supported by STEP 7 (Target system → Load to PG).
- Reading out diagnostics via the CPU 315-2 DP (with the "Diagnose hardware" function in STEP 7) is not possible up to Article No. 6ES7315-2AF02.

9.5.2 Configuring with the GSD file

Definition of the GSD

Device master data (GSD) contains DP slave descriptions in a standardized format. The use of device master data simplifies the configuration of the DP master and the DP slave.

Configuring with the GSD file

You configure the soft starter using the GSD file. The soft starter is integrated into your system as a standard slave by means of the GSD file.

You can download the GSD file from the Internet (<https://support.industry.siemens.com/cs/ww/en/view/113630>).

The following GSD files are available:

- SIEM80DE.GSG (German)
- SIEM80DE.GSE (English)
- SIEM80DE.GSF (French)
- SIEM80DE.GSI (Italian)
- SIEM80DE.GSS (Spanish)

NOTICE
Your configuration tool must support GSD files - Rev.3, for example STEP 7 V5.1+Service Pack 2 and higher.

Note

Only the values for parameter set 1 (PS1) (and those that are independent of the parameter set anyway, for example motor protection) can be set with the GSD file.

The default values are used for PS2 and PS3.

9.5.3 Configuring with the Soft Starter ES Professional software

You can also configure SIRIUS 3RW44 soft starters using the Soft Starter ES Premium software.

There are two possibilities when using PROFIBUS DP:

- Stand-alone program on PC or programming device with PROFIBUS DP connection
- Integration with the object manager (OM) in STEP 7
You can find detailed information about "Soft Starter ES" in the online help of the program.

9.5.4 Diagnostics package

Diagnostics package

A free diagnostics package is available for 3RW44 soft starters. It contains HMI diagnostics screens for a touch panel. The diagnostics package is available in English and German. You can download the diagnostics package (<https://support.industry.siemens.com/cs/ww/en/view/28557893>) from the Internet:

9.5.5 Soft Starter ES parameterization software

Soft Starter ES is the central software for commissioning, operating, and diagnostics of the SIRIUS 3RW44 High Feature soft starter series. You can download the Soft Starter ES parameterization software (<https://support.industry.siemens.com/cs/ww/en/view/28323168>) from the Internet. This is a free, 14-day test version.

9.6 PROFIBUS DP commissioning using the GSD file in STEP 7 (example)

9.6.1 Introduction

The following example shows you how to commission the PROFIBUS DP communication module.

- Installation and activation of the PROFIBUS DP communication module (fieldbus interface)
- Configuration with STEP 7 using the GSD file
- Integration into the user program
- Switching on

Components needed

- 3RW44 soft starter
- 3RW49 00-0KC00 communication module

General requirements

- You have configured an infeed module with integrated S7 station,
- e. g. with CPU315-2 DP.
- You are proficient in STEP 7.
- The programming device is connected to the DP master.

Software requirements

Table 9- 1 Software requirements for commissioning

Configuration software used	Version	Explanations
STEP 7	From version V5.1+SP2 onwards	You have integrated the GSD file of the soft starter into STEP 7.
Configuration software for the other DP master used		You have integrated the GSD file of the soft starter into the applicable configuration tool.

Requirements for commissioning

Table 9- 2 Requirements for commissioning

Prior activity	For more information, see ...
1. Soft starter has been installed	Chapter Installation, connection and feeder configuration (Page 31).
2. PROFIBUS DP communication module has been installed	Chapter Installing the PROFIBUS DP communication module (Page 164).
3. The station address has been set on the soft starter	Chapter Activating the PROFIBUS DP communication module (fieldbus interface) and setting the station address via the device interface using the "Soft Starter ES Premium" or the "Soft Starter ES Smart + SP1" software (Page 170).
4. The soft starter has been configured (configured and parameterized)	Chapter Configuring soft starters (Page 172).
5. The supply voltage for the DP master is switched on	DP master manual
6. The DP master is switched to the RUN operating state	DP master manual

9.6.2 Configuration using the Device Master Data (GSD) in STEP 7

Table 9- 3 Commissioning

Step	Description
1	Activate the PROFIBUS DP communication module as described in chapter Activating the PROFIBUS DP communication module (fieldbus interface) and setting the station address (Page 166).
2	Set the required station address as described in chapter Activating the PROFIBUS DP communication module (fieldbus interface) and setting the station address (Page 166).
3	Switch on the supply voltage for the DP master CPU 315-2 DP at the infeed module.
4	Observe the status LEDs of the DP master CPU 315-2 DP on the infeed module: 5 V DC: Lights up SF DP: Off BUSF: Flashing
5	Start the SIMATIC Manager and create a new project with a DP master (e.g. CPU315-2 DP with DI 16 x DC 24 V and DO 16 x DC 24 V). Generate OB1 and OB82 for the project.

9.6 PROFIBUS DP commissioning using the GSD file in STEP 7 (example)

Step	Description												
6	<p>In HW Config, call up the Extras > Install new GSD file menu command, and integrate the GSD file of the soft starter into the configuration tool of the DP master used. For the CPU315-2 used in the example, you can optionally install</p> <ul style="list-style-type: none"> • the German GSD file SIEM80DE.GSG, • the English GSD file SIEM80DE.GSE, • the French GSD file SIEM80DE.GSF, • the Spanish GSD file SIEM80DE.GSS, • the Italian GSD file SIEM80DE.GSI <p>in the STEP 7 SIMATIC Manager.</p>												
7	Generate the PROFIBUS DP subnet.												
8	Add the soft starter from the hardware catalog to the PROFIBUS under PROFIBUS DP > Additional field devices > Switching devices > Motor starters > Direct soft starters > SIRIUS 3RW44.												
9	Set the station address for the soft starter to 3 (or higher).												
10	<p>Drag a module from the selection list of the drop-down menu to slot 1 of the SIRIUS 3RW44:</p> <table border="1" style="margin-left: 40px;"> <thead> <tr> <th>Slot</th> <th>Module/ DP ID</th> <th>Order number</th> <th>I addr.</th> <th>O addr.</th> <th>Comment</th> </tr> </thead> <tbody> <tr> <td>1</td> <td>192</td> <td>3RW4422-*BC**</td> <td>2...3¹⁾</td> <td>2...3¹⁾</td> <td></td> </tr> </tbody> </table> <p>¹⁾ Depending on the structure Double-click to open the "Properties DP slave" dialog.</p>	Slot	Module/ DP ID	Order number	I addr.	O addr.	Comment	1	192	3RW4422-*BC**	2...3 ¹⁾	2...3 ¹⁾	
Slot	Module/ DP ID	Order number	I addr.	O addr.	Comment								
1	192	3RW4422-*BC**	2...3 ¹⁾	2...3 ¹⁾									
11	<p>Click on "Parameterize". Set the parameters, **), e.g.</p> <p>:</p> <p>Rated operational current</p> <p>:</p> <p>Click on OK. This completes the configuration.</p>												
12	Save the configuration.												

Note

During parameterization with the GSD file, it is possible to select values that are dependent on each other, but are not permissible in combination. The respective parameter is reported as an "Incorrect parameter value" in data set 92.

9.6 PROFIBUS DP commissioning using the GSD file in STEP 7 (example)

The following table shows which parameters are mutually dependent and how they must be set:

Table 9- 4 Interdependent parameter settings

Parameters		Settings
Rated operational current I _e	Depends on	Tripping class CLASS (refer to chapter Technical data of the power unit (Page 274))
Upper current limit	Greater than	Lower current limit, chapter Specifying current limit values (Page 93)
Maximum starting time	Greater than	Starting time, chapter Specifying the startup mode (Page 68)
Limiting torque	Greater than	Starting torque, chapter Specifying the startup mode (Page 68), torque control and torque control with current limiting.

9.6.3 Integration into the user program

Table 9- 5 Integration into the user program

Step	Description
1	<p>Create the user program in the LAD/STL/CSF editor in OB1. Example: reading an input and controlling an output:</p> <pre> OB1 : Title: Comment: Network 1: Title: Cyclically copy the central DIs (switches) to the decentralized motor starter (=PAA). Cyclically output the PAE of the motor starter to the central DOs (LED). L EB 0 // PAA: read in switches 0-7 (DI 16 x 24 V DC) T AB 2 // y emitir al arrancador de motor // EB0.0 Motor - RIGHT // EB0.1 Motor - LEFT // EB0.2 0 L EB 2 // Read in the motor starter PAE T AB 0 // and output to D016xDC24V </pre>
2	Save the project in SIMATIC Manager.
3	Load the configuration to the DP master.

9.6.4 Switching on

Table 9- 6 Switching on

Step	Description
1	Switch on the voltage supply for the soft starter.
2	Observe the status LEDs on the DP master CPU315-2 DP: 5 V DC: Lights up SF DP: Off BUSF: Off
3	Observe the status LEDs on the PROFIBUS module: LED BUS: Lights up green

9.6.5 Flow diagram: PROFIBUS DP starting the soft starter

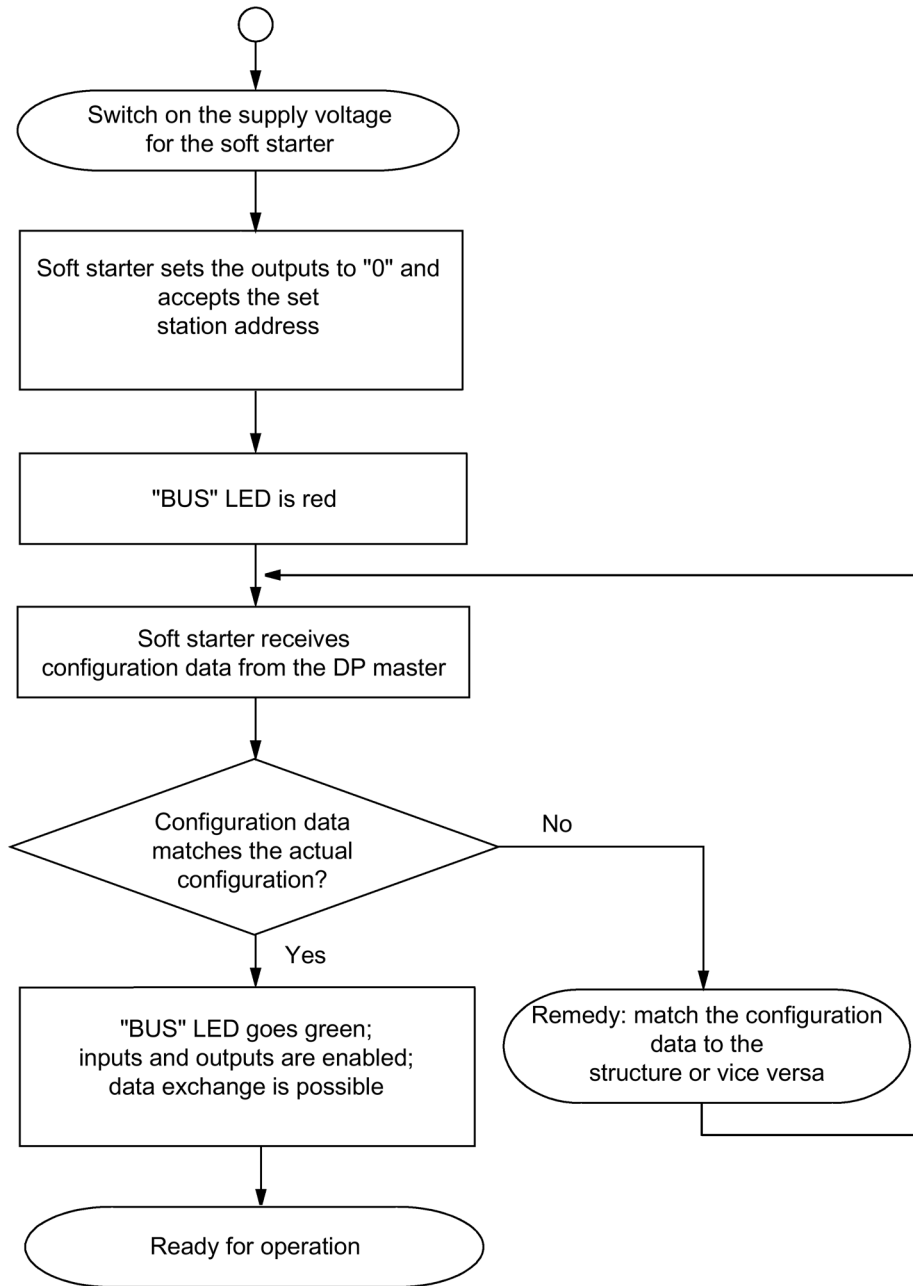

Figure 9-3 PROFIBUS DP starting of the soft starter

9.7 Process data and process images

Definition of process image

The process image is part of the system memory of the DP master. At the start of the cyclic program, the signal states of the inputs are transferred to the process image of the inputs. At the end of the cyclic program, the process image of the outputs is transferred to the DP slave as a signal status.

For soft starters with PROFIBUS DP, the following process image is available:

- Process image with 2 bytes of outputs/2 bytes of inputs (16 O/16 I)

Table 9- 7 Process data and process images

Process data		Process image: (16 O, DO 0.0 to DO 1.7) (16 I, DI 0.0 to DI 1.7)
DO-0.	0	Motor CW
	1	Motor CCW
	2	Not used
	3	Trip reset
	4	Emergency start
	5	Available
	6	Slow speed
	7	Not used
DO-1.	0	Output 1
	1	Output 2
	2	Parameter set bit 0 ^{*)}
	3	Parameter set bit 1 ^{*)}
	4	Not used
	5	Not used
	6	Not used
	7	Disable quick stop
Inputs		
DI-0.	0	Ready (automatic)
	1	Motor ON
	2	Group fault
	3	Group warning
	4	Input 1
	5	Input 2
	6	Input 3
	7	Input 4

Process data		Process image: (16 O, DO 0.0 to DO 1.7) (16 I, DI 0.0 to DI 1.7)
DI-1.	0	Motor current $I_{act-bit0}$
	1	Motor current $I_{act-bit1}$
	3	Motor current $I_{act-bit2}$
	4	Motor current $I_{act-bit3}$
	5	Motor current $I_{act-bit4}$
	6	Manual mode local
	7	Ramp operation

) See the table below

Process image error	Parameter set 3	Parameter set 2	Parameter set 1
	PS3	PS2	PS1
1	0	1	0
1	1	0	0

9.8 Diagnosis via LED display

Table 9- 8 Diagnosis via LED display

	LED	Description
BUS	Red	Bus fault
	Red blinking	Parameterization error
	Red flickering	Basic factory settings restored (red flickering for 5 sec)
	Red-green toggling*)	Parameter error while starting S7
	Green	Device exchanging data
	Yellow	Device not initialized and bus error! (Send in device!)
	Yellow-green blinking	Device not initialized and parameter error! (Send in device!)
	Off	Device not exchanging data!
Specifications		
Error:	BF = bus fault	
Frequency specifications:	Blinking:	0.5 Hz
	Flickering:	8 to 10 Hz
	*) Toggling:	2 to 10 Hz

9.9 Diagnosis with STEP 7

9.9.1 Reading out the diagnostic data

Length of the diagnostics message frame

The maximum message frame length is 32 bytes.

9.9.2 Options for reading diagnostic data

Table 9- 9 Reading out the diagnostics information with STEP 7

Automation system with DP master	Blocks or registers in STEP 7	Application	See ...
SIMATIC S7/M7	SFC 13 "DP NRM_DG"	Reading slave diagnostic data (stored in the data area of the user program)	Chapter Structure of the slave diagnostics (Page 184); for SFC, see online help in STEP 7

Example of reading out S7 diagnostics using SFC 13 "DP NRM_DG"

This is an example of how to use the SFC 13 to read out the slave diagnostics for a DP slave in the STEP 7 user program.

Assumptions

The following assumptions apply for this STEP 7 user program:

- Diagnostics address is 1022 (3FEH).
- Slave diagnostic data must be stored in DB82: from address 0.0, length 32 bytes.
- The slave diagnostic data has a length of 32 bytes.

STEP 7 user program

STL	Explanation
CALL SFC 13	
REQ :=TRUE	Read request
LADDR :=W#16#3FE	Diagnostic address
RET_VAL :=MW0	RET_VAL of SFC 13
RECORD :=P#DB82.DBX 0.0 BYTE 32	Mailbox for diagnostic data in DB82
BUSY :=M2.0	Read process runs over several OB1 cycles

9.9.3 Structure of the slave diagnostics

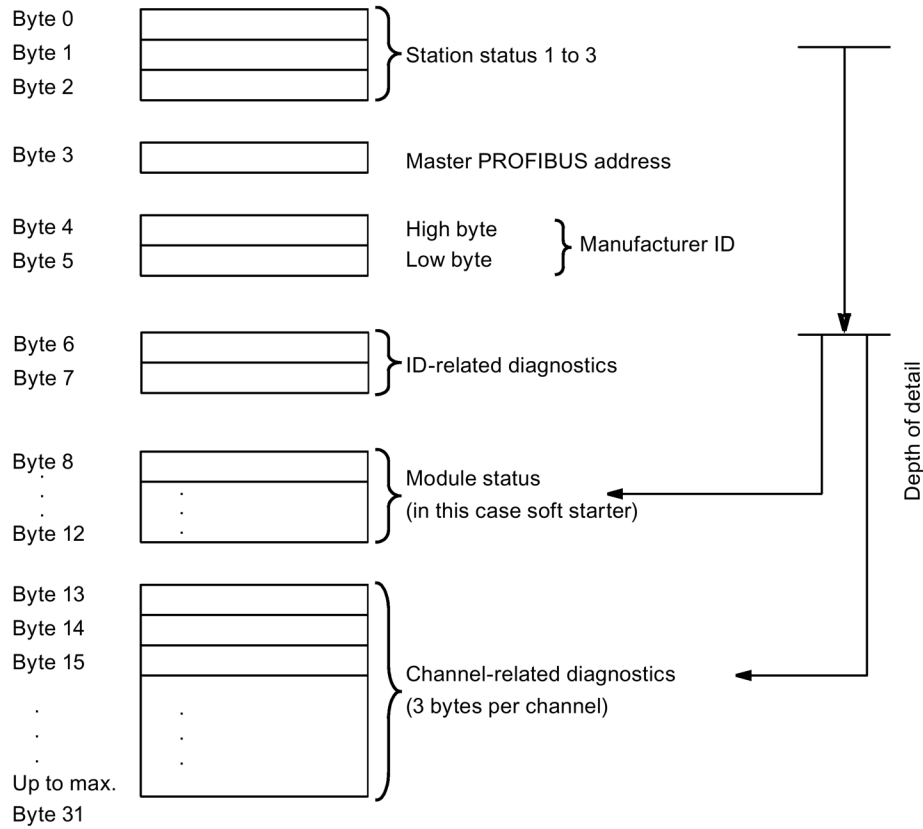

Figure 9-4 Structure of the slave diagnostics

Note

The length of the diagnostics message frame varies between 13 and 32 bytes. The length of the diagnostics message frame last received can be seen in STEP 7 from the RET_VAL parameter of SFC 13.

9.9.4 Station status 1 to 3

Definition

The station status 1 to 3 provides an overview of the status of a DP slave.

Table 9- 10 Structure of station status 1 (byte 0)

Bit	Meaning	Cause/remedy
0	1: The DP master cannot address the DP slave.	<ul style="list-style-type: none"> • Correct station address set on the DP slave? • Is the bus connector in place? • Voltage at the DP slave? • Is the RS 485 repeater set correctly? • Reset triggered on the DP Slave?
1	1: The DP slave is not yet ready for the data transfer.	<ul style="list-style-type: none"> • Wait, the DP slave is currently starting up.
2	1: The configuration data transferred from the DP master to the DP slave does not match the DP slave configuration.	<ul style="list-style-type: none"> • Verify the station type or DP slave configuration in the configuration software.
3	1: External diagnostics information is pending (group diagnostics indication)	<ul style="list-style-type: none"> • Evaluate the ID-specific and/or channel-specific diagnostic information, and the module status. As soon as all errors are remedied the bit 3 is reset. The bit will be set again when there is a new diagnostics message in the bytes of the aforementioned diagnostics.
4	1: The required function is not supported by the DP slave (for example, changing the station address by means of software).	<ul style="list-style-type: none"> • Check the configuration.
5	1: The DP master cannot interpret the response of the DP slave.	<ul style="list-style-type: none"> • Check the bus configuration.
6	1: The DP slave type does not match the software configuration.	<ul style="list-style-type: none"> • Has the correct station type been entered in the configuration software?
7	1: The DP slave has been parameterized by another DP master (not by the DP master that has access to the DP slave at the moment).	<ul style="list-style-type: none"> • The bit is always 1, for example, if you access the DP slave with the PG or another DP master. The "Master PROFIBUS address" diagnostic byte contains the station address of the DP master that assigned parameters to the DP slave.

Station status 2

Table 9- 11 Structure of station status 2 (byte 1)

Bit		Meaning
0	1:	The DP slave must be parameterized again.
1	1:	A diagnostic message is pending. The DP slave will not work until the fault is rectified (static diagnostic message).
2	1:	The bit is always "1" when the DP slave with this station address is configured.
3	1:	Response monitoring is enabled for this DP slave.
4	1:	The DP slave has received the "FREEZE" control command. ¹⁾
5	1:	The DP slave has received the "SYNC" control command. ¹⁾
6	0:	Bit is always "0".
7	1:	The DP slave is deactivated, i.e. it is decoupled from the current processing.

¹⁾ The bit is only updated if another diagnostics message also changes.

Station status 3

Table 9- 12 Structure of station status 3 (byte 2)

Bit		Meaning
0 to 6	0:	Bits are always "0".
7	1:	<ul style="list-style-type: none"> • There are more diagnostics messages pending than the DP slave is able to store. • The DP master cannot enter all the diagnostics messages sent by the DP slave in its diagnostics buffer (channel-specific diagnostics).

9.9.5 Master PROFIBUS address

The master PROFIBUS address diagnostics byte contains the station address of the DP master:

- that has parameterized the DP slave and
- has read and write access to the DP slave.

The master PROFIBUS address is stored in byte 3 of the slave diagnostics.

9.9.6 Manufacturer ID

Definition

The manufacturer's ID contains a code specifying the DP slave type.

Table 9- 13 Structure of the manufacturer ID

Byte 4	Byte 5	Manufacturer ID for
80 _H	DE _H	Soft starter

9.9.7 ID-related diagnostics

Definition

Identifier-related diagnostic data indicates whether soft starters are faulty or not. Identifier-related diagnostics begins at byte 6 and is 2 bytes long.

ID-related diagnostics

Identifier-related diagnostics for soft starters is structured as follows:

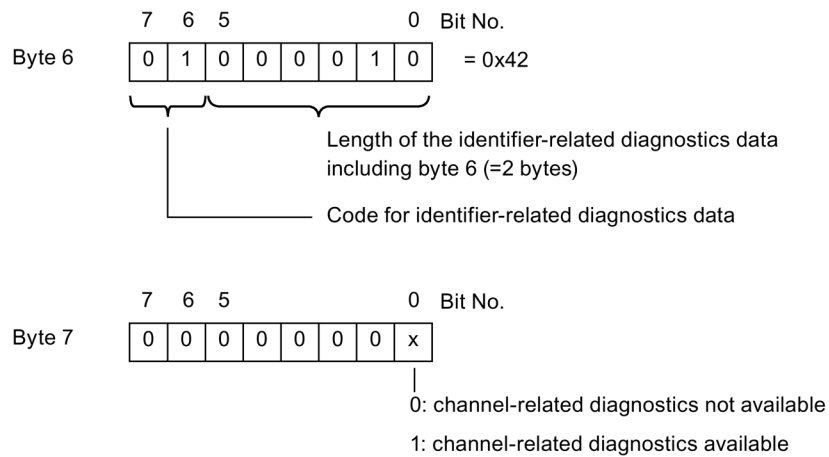

Figure 9-5 Configuration of identifier-related diagnostics

9.9.8 Module status

Definition

The module status represents the status of the configured modules (in this case: soft starters) and provides details of the identifier-related diagnostics. The module status starts after the identifier-related diagnostics and consists of 5 bytes.

Structure of the module status

The module status is structured as follows:

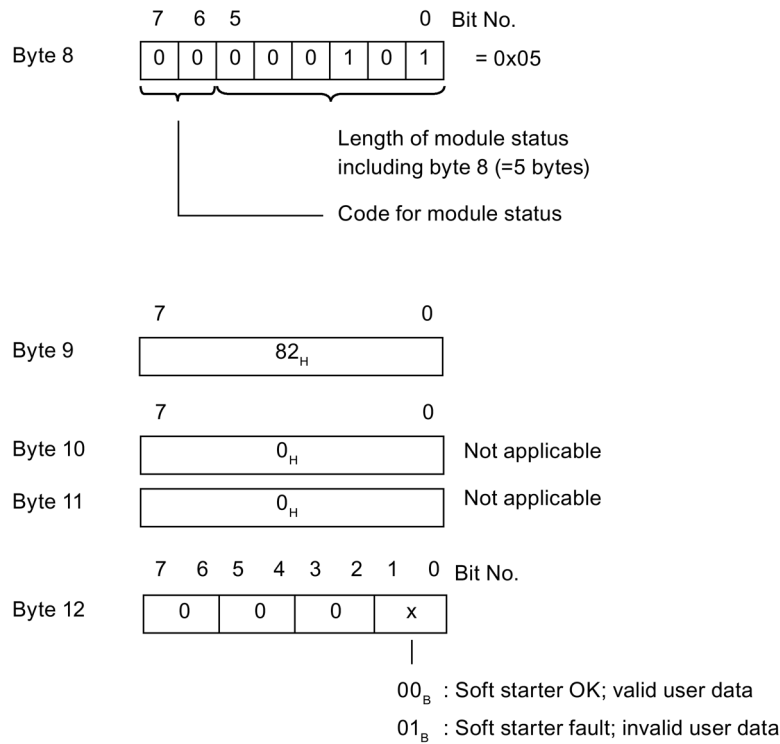

Figure 9-6 Structure of the module status

9.9.9 Channel-related diagnostics

Definition

Channel-related diagnostics provides information about channel faults in modules (in this case: soft starters) and provides details of the identifier-related diagnostics. Channel-related diagnostics begins after the module status. The maximum length is limited by the maximum total length of slave diagnostics amounting to 31 bytes. Channel-related diagnostics does not affect the module status.

Up to 9 channel-related diagnostics messages are possible (see also station status 3, bit 7).

Channel-related diagnostics

Channel-related diagnostics is configured as follows:

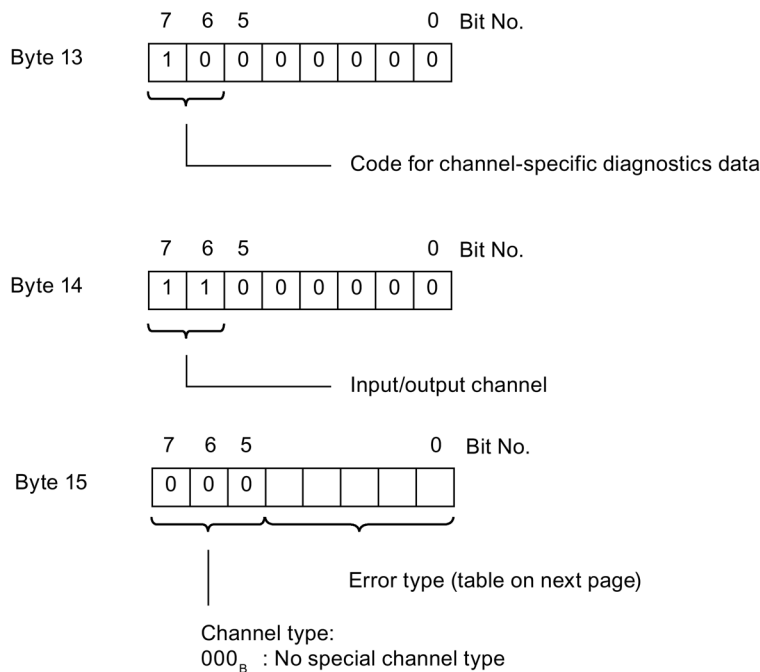

Byte 16 to 18: Next channel-specific diagnostic message (same assignments as bytes 13 to 15)
 Up to 31 max.

Figure 9-7 Configuration of the channel-related diagnostics

Note

Channel-related diagnostics is always updated up to the current diagnostics message in the diagnostics message frame. Subsequent, older diagnostics messages are not deleted.

Remedy: Evaluate the valid, current length of the diagnostics message frame:

- STEP 7 from the parameter RET_VAL of SFC 13.

Fault types

The diagnostics alarm is signaled on channel 0.

Table 9- 14 Fault types

Fault No.	Fault type	Meaning/cause	Delete alarm bit/acknowledgement
F1	00001: Short-circuit	<ul style="list-style-type: none"> Short-circuit of the temperature sensor 	Alarm bit is automatically deleted when the cause of the fault has been removed and acknowledged with "trip reset".
F4	00100: Overload	<ul style="list-style-type: none"> Overload of the temperature sensor Overload of the thermal motor model 	Alarm bit is updated continually.
F5	00101: Overtemperature	<ul style="list-style-type: none"> Overload of the contact block 	Alarm bit is automatically deleted when the cause of the fault has been removed and acknowledged with "trip reset".
F6	00110: Wire break	<ul style="list-style-type: none"> Wire break of the temperature sensor 	Alarm bit is updated continually.
F7	00111: Maximum limit value exceeded	<ul style="list-style-type: none"> I_e limit value overshoot 	
F8	01000: Minimum limit value undershot	<ul style="list-style-type: none"> I_e limit value undershot 	
F9	01001: Error	<ul style="list-style-type: none"> Internal error/device error Contact block defective 	Alarm bit can be deleted when the cause of the error has been eliminated by <ul style="list-style-type: none"> Switching the supply voltage On and Off "Restart" command if possible
F16	10000: Parameterization error	<ul style="list-style-type: none"> Invalid parameter value 	Alarm bit is always deleted when acknowledged with "trip reset".
F17	10001: No sensor or load voltage	<ul style="list-style-type: none"> Electronics supply voltage too low No contact block supply voltage No supply voltage 	Alarm bit is deleted when the cause of tripping has been eliminated or automatically acknowledged.
F24	11000: Actuator tripping	<ul style="list-style-type: none"> Tripping due to overload Tripping due to zero current Tripping due to asymmetry Tripping due to ground fault 	Alarm bit is always deleted when acknowledged with "trip reset". Additional acknowledgment in combination with another error.
F26	11010: External fault	<ul style="list-style-type: none"> Overload of the sensor supply Process image error 	Alarm bit is always deleted when acknowledged with "trip reset".

9.10 Data formats and data sets

9.10.1 Properties

The soft starter evaluates a large amount of operating, diagnostic, and statistical data.

Control data

Data that is transferred to the soft starter, e.g. motor CCW switching command, trip reset, etc.

Data format: Bit

Messages

Data that is transferred from the soft starter and indicates the current operating status, e.g., Motor CCW, etc.

Data format: Bit

Diagnostics

Data that is transferred from the soft starter and indicates the current operating status, e.g., Overload fault, etc.

Data format: Bit

Current values

Current values are coded in different current formats, namely in

- 6-bit current format,
- 8-bit current format, and
- 9-bit current format:

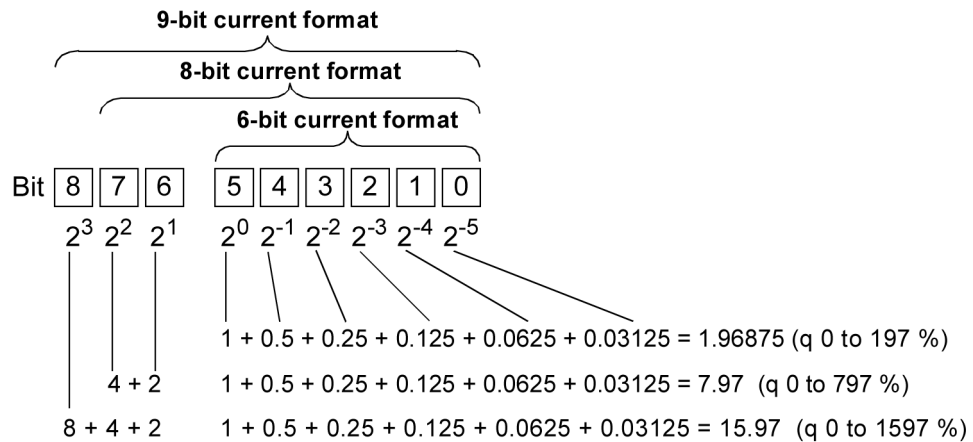

Figure 9-8 Current formats

Current values are

- Motor current I_{max} (6-bit current format)
- Phase currents I_{L1max} , I_{L2max} , I_{L3max} (8-bit current format)
- Last trigger current (9-bit current format)
- Maximum tripping current (9-bit current format)

Statistical data on device service life

- Operating hours

The soft starter records 2 operating hour values:

- Motor operating hours

Specifies for how long the motor was switched on

- Operating hours of the device (soft starter)

This indicates how long the 115 V AC or 230 V AC voltage supply of the soft starter was switched on.

Both operating hour values are recorded in data set 95 - "Read statistics". They are entered in the "Operating hours" data field at 1-second intervals. The operating hours are recorded in the range from 0 to 232 seconds in 1-second increments.

- Number of overload trips

The soft starter counts the number of overload trips in the range from 0 to 65535.

- Number of starts motor CW/CCW

The soft starter counts the number of starts in the range from 0 to 232

Example: if current flows in the main circuit after the "Motor ON" command, the value is incremented by 1.

- Number of starts, outputs 1 to 4

- Motor current I_{max}

The soft starter measures the current in all 3 phases and displays the current of the highest loaded phase as a percentage [%] of the set current I_e .

Data format: 1 byte, 8-bit current format

Example: Set current $I_e = 60$ A

Displayed motor current 110 %

then corresponds to $60 \text{ A} \times 1.1 = 66 \text{ A}$

All 3 phase currents are available in data block 94

- Last trip current

The soft starter measures the current in all 3 phases and displays the current that is flowing in the highest loaded phase when tripping occurs as a percentage [%] of the set current I_e and in amperes [A]

Data format: 2 byte, 9-bit current format

Example: Set current $I_e = 60$ A

Indicated motor current 455 % then corresponds to $60 \text{ A} \times 4.55 = 273 \text{ A}$

Statistics data of the maximum pointer

Maximum pointers are used for preventive diagnostics:

- The maximum measured value is stored in the device.
- The higher-level PLC can retrieve the measured value at any time.
- The higher-level PLC can reset the measured value at any time.

The following data is available as a maximum pointer:

- Number of overload trips.
- Phase current I_{L1max} to I_{L3max} and I_{L1min} to I_{L3min} . Maximum and minimum phase current as a percentage [%] of set current I_e and in amperes [A]

Data format: 1 byte each, 8-bit current format

Both the measured maximum and minimum phase currents in bypass operation are stored per phase.

- Minimum and maximum phase-to-phase voltages $U_{Lx} - U_{Ly}$ as RMS values in 0.1 V. Minimum and maximum line frequency in 0.5 Hz resolution.

9.11 Identification number (ID No.), error codes

9.11.1 Identification number (ID No.)

The identification number (ID No.) is used for unique identification of all the information available in the motor starter (parameters, control commands, diagnostics, commands, etc.). It is located in the left-hand column of the data set tables.

9.11.2 Error codes for negative data set acknowledgement

Description

If a data set is rejected, an error code is sent with the negative acknowledgment, both via the device interface and via the bus interface. This provides information about the reason for the negative acknowledgment.

The error codes comply with the PROFIBUS-DPV1 standard in as far as it applies to the soft starter.

Evaluation via local device interface with Soft Starter ES

The error codes are evaluated by the Soft Starter ES parameterization and diagnostic software and output in plain text. More information on this can be found in the online help of Soft Starter ES.

Evaluation via PROFIBUS DP

The error codes are output via PROFIBUS DP Layer 2. More information can be found in the relevant manuals for the PROFIBUS DP protocol description.

Error codes

The following error codes are generated by the soft starter:

Table 9- 15 Error codes

Error codes		Error message	Cause
Byte			
High	Low		
00H	00H	No error	
Communication interface			
80H	A0H	Negative acknowledgement for "Read data set"	<ul style="list-style-type: none"> Data set write-only
80H	A1H	Negative acknowledgement for "Write data set"	<ul style="list-style-type: none"> Data set read-only
80H	A2H	Protocol error	<ul style="list-style-type: none"> Layer 2 (fieldbus) Device interface Incorrect coordination
80H	A9H	This function is not supported	<ul style="list-style-type: none"> DPV1 service does not support Read/write data set
Access to technology			
80H	B0H	Unknown data set number	<ul style="list-style-type: none"> Data set number not known in the soft starter
80H	B1H	Incorrect data set length when writing	<ul style="list-style-type: none"> Data set length and specified data set length different
80H	B2H	Incorrect slot number	<ul style="list-style-type: none"> Slot not 1 or 4
80H	B6H	Communication partner declined data acceptance!	<ul style="list-style-type: none"> Incorrect operating mode (automatic, manual bus, manual mode local) Data set is read-only Parameters cannot be changed in ON state
80H	B8H	Invalid parameter	<ul style="list-style-type: none"> Invalid parameter value
Device resources			
80H	C2H	Temporary lack of resources in the device!	<ul style="list-style-type: none"> No free receive buffer The data set is currently being updated The data set request is currently active on another interface.

9.12 Data sets (BS)

Reading/writing data sets with STEP 7

You can access the data sets of the soft starter from the user program.

- Writing data sets:
 S7-DPV1 master: By calling up SFB 53 "WR_REC" or SFC 58
 S7 master: by calling up SFC 58
- Reading data sets:
 S7-DPV1 master: by calling up SFB 52 "RD_REC" or SFC 59
 S7 master: by calling up SFC 59

Further information

You can find additional information about the SFBs

- in the reference manual "System Software for S7-300/400, System and Standard Functions" (<https://support.industry.siemens.com/cs/ww/en/view/1214574>)
- in the STEP 7 online help

Byte arrangements

When data longer than one byte is stored, the bytes are arranged as follows ("big endian"):

Byte arrangement		Data type
Byte 0	High byte	High word
Byte 1	Low byte	
Byte 2	High byte	Low word
Byte 3	Low byte	
Byte 0	High byte	Word
Byte 1	Low byte	
Byte 0	Byte 0	Byte
Byte 1	Byte 1	

Figure 9-9 Byte arrangement in "big endian" format

9.12.1 Data set 68 - Reading/writing the process image of the outputs

Note

Note that data set 68 is overwritten by the cyclic process image in automatic mode!

Byte	Meaning
	Header
0	Writing coordination 0x20 via channel C1 (PLC) Writing 0x30 via channel C2 (PC) Writing 0x40 via device interface (PC)
1 - 3	Reserved = 0
	Process image of the outputs
4	Process data DO-0.0 to DO-0.7, table below
5	Process data DO-1.0 to DO-1.7, table below
6	Reserved = 0
7	Reserved = 0

Table 9- 16 Data set 68 - Reading/writing the process image of the outputs

ID No.	Process data		Process image (16 O (outputs), DO 0.0 to DO 1.7)
	DO-0.		
1001	DO-0.	0	Motor CW
1002		1	Motor CCW
1003		2	Not used
1004		3	Trip reset
1005		4	Emergency start
1006		5	Not used
1007		6	Slow speed
1008		7	Not used
1009	DO-1.	0	Output 1
1010		1	Output 2
1011		2	Parameter set bit 0
1012		3	Parameter set bit 1
1013		4	Not used
1014		5	Not used
1015		6	Not used
1016		7	Disable quick stop

In the "Automatic mode", the PLC specifies the process image of the outputs. In this case, reading of data set 68 at the local device interface returns the process image of the outputs as transmitted by the PLC.

9.12.2 Data set 69 - Reading the process image of the inputs

Byte	Meaning
	Process image of the inputs
0	Process data DI-0.0 to DI-0.7, table below
1	Process data DI-1.0 to DI-1.7, table below
2	Reserved = 0
3	Reserved = 0

Table 9- 17 Data set 69 - Reading the process image of the inputs

ID No.	Process data	Process image: (16 I (inputs), DI 0.0 to DI 1.7)
1101	DI-0.	0 Ready (automatic)
1102		1 Motor ON
1103		2 Group fault
1104		3 Group warning
1105		4 Input 1
1106		5 Input 2
1107		6 Input 3
1108		7 Input 4
1109	DI-1.	0 Motor current $I_{act-bit0}$
1110		1 Motor current $I_{act-bit1}$
1111		2 Motor current $I_{act-bit2}$
1112		3 Motor current $I_{act-bit3}$
1113		4 Motor current $I_{act-bit4}$
1114		5 Motor current $I_{act-bit5}$
1115		6 Manual mode local
1116		7 Ramp operation

9.12.3 Data set 72 - Logbook - Reading device errors

Table 9- 18 Data set 72 - Logbook - Reading device errors

Byte	Meaning	Value range	Increment	Note
0 - 3	Operating hours - device	1 ... 2^{32} s	1 second	Oldest entry
4 - 5	ID number of the device error	0 ... ± 32767 s	1	
6 - 9	Operating hours - device	1 ... 2^{32} s	1 second	Second oldest entry
10 - 11	ID number of the device error	0 ... ± 32767 s	1	
etc.				
120 - 123	Operating hours - device	1 ... 2^{32} s	1 second	Last, newest entry
124 - 125	ID number of tripping operation	0 ... ± 32767 s	1	

This data set can accommodate 21 entries. When all locations have been written, the first entry is overwritten again.

Note

The newest entry is entered at the end of the data set. The remaining entries are moved up one entry.

The following messages can be entered:

ID No.	Device fault - messages
452	Heatsink - thermistor defective
1466	Contact 1 failed
1467	Contact 2 failed
1468	Contact 3 failed
1417	Bypass element defective

9.12.4 Data set 73 - Logbook – Reading the trips

Table 9- 19 Data set 73 - Logbook – Reading the trips

Byte	Meaning	Value range	Increment	Note
0 - 3	Operating hours - device	1 ... 2^{32} s	1 second	Oldest entry
4 - 5	ID number of the device error	0 ... ± 32767	1	
6 - 9	Operating hours - device	1 ... 2^{32} s	1 second	Second oldest entry
10 - 11	ID number of the device error	0 ... ± 32767	1	
etc.				
120 - 123	Operating hours - device	1 ... 2^{32} s	1 second	Last, newest entry
124 - 125	ID number of tripping operation	0 ... ± 32767	1	

This data set can accommodate 21 entries. When all locations have been written, the first entry is overwritten again.

Note

The newest entry is entered at the end of the data set. The remaining entries are moved up one entry.

The following messages can be entered:

Table 9- 20 Messages in the logbook - Reading the trips

ID No.	Trips - messages
309	Contact block overload
317	Electronics supply voltage too low
319	No supply voltage
324	Temperature sensor overload
325	Temperature sensor wire break
326	Temperature sensor short-circuit
327	Thermal motor model overload
334	I _e limit value overshoot
335	I _e limit value undershoot
339	Motor stalled - switched off
341	Asymmetry tripping
343	Ground fault tripping
355	Process image error
365	Invalid parameter value
ID No. of incorrect parameter	
1407	Electronics supply voltage too high
1408	No load
1409	Phase failure L1
1410	Phase failure L2
1411	Phase failure L3
1421	Impermissible I _e /CLASS setting
1479	Phase angle control failure
1481	System voltage too high
1482	Current measuring range overshoot

9.12.5 Data set 75 - Logbook - Reading events

Table 9- 21 Data set 75 - Logbook - Reading events

Byte	Meaning	Value range	Increment	Note
0 - 3	Operating hours - device	1 ... 2 ³² s	1 second	Oldest entry
4 - 5	ID number of the device error	0 ... ± 32767 ⁾	1	
6 - 9	Operating hours - device	1 ... 2 ³² s	1 second	Second oldest entry
10 - 11	ID number of the device error	0 ... ± 32767 ⁾	1	
etc.				
120 - 123	Operating hours - device	1 ... 2 ³² s	1 second	Last, newest entry
124 - 125	ID number of tripping operation	0 ... ± 32767 ⁾	1	

⁾ + incoming event, - outgoing event

This data set can accommodate 21 entries. When all locations have been written, the first entry is overwritten again.

Note

The newest entry is entered at the end of the data set. The remaining entries are moved up one entry.

The following messages can be entered:

Table 9- 22 Messages in the logbook - Reading events

ID No.	Events - messages	Note
Warnings		
324	Temperature sensor overload	± (coming/going event)
325	Temperature sensor wire break	± (coming/going event)
326	Temperature sensor short-circuit	± (coming/going event)
327	Thermal motor model overload	± (coming/going event)
334	I _e current limit exceeded	± (coming/going event)
335	I _e current limit undershot	± (coming/going event)
340	Asymmetry detected	± (coming/going event)
342	Ground fault detected	± (coming/going event)
Actions		
310	Emergency start active	± (coming/going event)
357	Automatic mode	+ (coming event only)
358	Manual bus mode	+ (coming event only)
359	Manual mode local	+ (coming event only)
360	Connection abort in manual mode	+ (coming event only)
363	Maximum pointer deleted	+ (coming event only)
365	Invalid parameter value	+ (coming event only)
ID No. of incorrect parameter		
366	Parameters cannot be changed in ON state	+ (coming event only)
ID No. of incorrect parameter		
368	Parameters disabled CPU/master active	± (coming/going event)
369	Factory settings restored	+ (coming event only)
1302	Logbook - trips deleted	+ (coming event only)
1303	Logbook - events deleted	+ (coming event only)

9.12.6 Data set 81 - Reading the basic settings of data set 131

Data set 81 corresponds in structure and content to data set 131. Data set 81 supplies the default values for all parameters of data set 131.

9.12.7 Data set 82 - Reading the basic settings of data set 132

Data set 82 corresponds in structure and content to data set 132. Data set 82 supplies the default values for all parameters of data set 132.

9.12.8 Data set 83 - Reading the basic settings of data set 133

Data set 83 corresponds in structure and content to data set 133. Data set 83 supplies the default values for all parameters of data set 133.

9.12.9 Data set 92 - Reading device diagnostics

Table 9- 23 Data set 92 - Reading device diagnostics

ID No.	Byte ^{Bit}	Alarm bit	Error No. ^{*)}	Meaning/acknowledgment
Switching/controlling				
301	0 ⁰	Ready (automatic)	-	Device is ready for operation via host (e.g. PLC), alarm bit is updated continually.
306	0 ¹	Motor CW	-	Contact block 1 is switched on, alarm bit is updated continually.
307	0 ²	Motor CCW	-	Contact block 2 is switched on, alarm bit is updated continually.
309	0 ³	Contact block overload	F5, F24	e.g. power semiconductor too hot, causing motor to trip. Alarm bit is automatically deleted when the cause of the fault has been removed and acknowledged with "trip reset".
308	0 ⁴	Contact block defective	F9	e.g. contactor is fusion-welded/jammed or power semiconductor has fused. Alarm bit can only be deleted by switching the supply voltage on and off once the cause of the error has been eliminated.
310	0 ⁵	Emergency start active	-	Alarm bit is deleted when emergency start is deactivated.
302	0 ⁶	Group fault	-	At least 1 error that generates an E No. is set. Alarm bit is deleted when the cause of tripping has been eliminated and acknowledged with "trip reset, auto reset, OFF command"
304	0 ⁷	Group warning	-	At least 1 warning is pending, alarm bit is updated continually.
	1 ⁰	Reserved = 0	-	
319	1 ¹	No supply voltage	F17, F24	Alarm bit is automatically deleted when the cause of the fault has been removed and acknowledged with "trip reset".
	1 ²	Reserved = 0	-	
312	1 ³	Starting active	-	Alarm bit is updated continually.
313	1 ⁴	Coast down active	-	
	1 ⁵	Reserved = 0	-	
316	1 ⁶	Electrical braking active	-	Brake output is switched on by the soft starter, alarm bit is updated continually.
314	1 ⁷	Slow speed active	-	Alarm bit is updated continually.

ID No.	Byte ^{Bit}	Alarm bit	Error No. ^{*)}	Meaning/acknowledgment
Protective function: Motor/cable/ short-circuit				
324	2 ⁰	Temperature sensor overload	F4	Overload detected, alarm bit is updated continually.
325	2 ¹	Temperature sensor wire break	F6	Thermistor circuit interrupted, alarm bit is updated continually.
326	2 ²	Temperature sensor short-circuit	F1	Short-circuit in thermistor circuit, alarm bit is updated continually.
327	2 ³	Thermal motor model overload	F4	Overload detected, alarm bit is updated continually.
328	2 ⁴	Overload tripping	F24	Motor is tripped due to a detected overload. Alarm bit is automatically deleted when the cause of the fault has been removed and acknowledged with "trip reset"/"auto reset".
329	2 ⁵	Idle time active	-	Alarm bit is updated continually.
330	2 ⁶	Cooling time active	-	Alarm bit is updated continually.
	2 ⁷	Reserved = 0	-	
	3 ⁰⁻⁶	Reserved = 0	-	
352	3 ⁷	Input control	-	Device receives control commands via the inputs, alarm bit is updated continually.
340	4 ⁰	Asymmetry detected	-	Asymmetry is present, alarm bit is updated continually.
341	4 ¹	Asymmetry tripping	F24	Tripping of the motor due to asymmetry. Alarm bit is automatically deleted when the cause of the fault has been removed and acknowledged with "trip reset".
334	4 ²	I _e limit value overshoot	F7	Limit exceeded, alarm bit is updated continually.
335	4 ³	I _e limit value undershot	F8	Limit undershot, alarm bit is updated continually.
336	4 ⁴	I _e current limit tripping	F24	Alarm bit is automatically deleted when the cause of the fault has been removed and acknowledged with "trip reset".
	4 ⁵	Reserved = 0	-	
	4 ⁶	Reserved = 0	-	
339	4 ⁷	Motor stalled - switched off	F24	Trip, stalling current detected for longer than the permitted stalling time. Alarm bit is automatically deleted when the cause of the fault has been removed and acknowledged with "trip reset".
344	5 ⁰	Input 1	-	States of the inputs "1" = active, HIGH level is present "0" = inactive, LOW level is present Alarm bit is updated continually.
345	5 ¹	Input 2	-	
346	5 ²	Input 3	-	
347	5 ³	Input 4	-	
	5 ⁴⁻⁷	Reserved = 0	-	
342	6 ⁰	Ground fault detected	-	Ground fault is present, alarm bit is updated continually.
343	6 ¹	Ground fault tripping	F24	Tripping of the motor due to ground fault. Alarm bit is automatically deleted when the cause of the fault has been removed and acknowledged with "trip reset".

9.12 Data sets (BS)

ID No.	Byte ^{Bit}	Alarm bit	Error No. ^{*)}	Meaning/acknowledgment
353	6 ²	Quick stop active	F26, F24	Tripping of the motor due to quick stop. Alarm bit is automatically deleted when the cause of the fault has been removed and acknowledged with "trip reset".
	6 ³	Reserved = 0	-	
361	6 ⁴	Trip reset successful	-	Alarm bit is deleted by an update or by a "Trip Reset" in ready for operation status.
362	6 ⁵	Trip reset not possible	-	Tripping cause is still present. Alarm bit is deleted by an update (new "Trip Reset") or by a "Trip Reset" in ready for operation status.
363	6 ⁶	Maximum pointer deleted	-	Alarm bit is always deleted when acknowledged with "trip reset".
317	6 ⁷	Electronics supply voltage too low	-	Alarm bit is deleted automatically when the cause of tripping has been eliminated.
Communication				
303	7 ⁰	Bus fault	-	Watchdog timer of DP interface has elapsed, alarm bit is updated continually.
356	7 ¹	CPU/Master STOP	-	PLC program is no longer being executed, alarm bit is updated continually.
357	7 ²	Automatic mode	-	Automatic (PLC controlled), alarm bit is updated continually.
358	7 ³	Manual bus mode	-	Manual mode via fieldbus (HMI controls), alarm bit is updated continually.
359	7 ⁴	Manual mode local	-	Manual mode via local device interface, (HMI controls), alarm bit is updated continually.
	7 ⁵	Reserved = 0	-	
360	7 ⁶	Connection abort in manual mode local	-	During manual mode, the related communication connection was interrupted, alarm bit is updated continually.
355	7 ⁷	Process image error	F26, F24	Process image of the outputs contains an impermissible bit combination. Alarm bit is deleted automatically when the cause of tripping has been eliminated.
Parameters				
364	8 ⁰	Parameter assignment active	-	Alarm bit is updated continually.
365	8 ¹	Invalid parameter value	F16	Alarm bit is always deleted when acknowledged with "Trip Reset" or valid parameters have been received.
366	8 ²	Parameters cannot be changed in ON state	-	Attempted parameter change while motor is running or during relevant device function, which has caused the trip. Alarm bit is always deleted when acknowledged with "Trip Reset" or valid parameters have been received.
368	8 ³	Parameters disabled CPU/master active	-	Alarm bit is updated continually, soft starter ignores parameters from the PLC.
	8 ⁴⁻⁷	Reserved = 0	-	

ID No.	Byte ^{Bit}	Alarm bit	Error No. ^{*)}	Meaning/acknowledgment
Device functions				
	9 ⁰⁻²	Reserved = 0	-	
369	9 ³	Factory settings restored	-	Alarm bit is always deleted when acknowledged with "trip reset".
	9 ⁴⁻⁷	Reserved = 0	-	
367	10	Incorrect parameter number (low byte)	-	In conjunction with bytes 81 and 82, specifies the ID No. of the first parameter not accepted.
	11	Incorrect parameter number (high byte)	-	Alarm bit is always deleted when acknowledged with "trip reset".
	12 ⁰⁻¹	Reserved = 0	-	
1421	12 ²	Impermissible I _e /CLASS setting	-	
	12 ³⁻⁷	Reserved = 0	-	
1449	13 ⁰	Parameter set 1 active	-	
1450	13 ¹	Parameter set 2 active	-	
1451	13 ²	Parameter set 3 active	-	
	13 ³	Reserved = 0	-	
1453	13 ⁴	Parameter set change impermissible	-	
	13 ⁵⁻⁷	Reserved = 0	-	
	14 ⁰⁻¹	Reserved = 0	-	
1404	14 ²	Motor heating active	-	
1402	14 ³	DC braking active	-	
1403	14 ⁴	Dynamic DC braking active	-	
1471	14 ⁵	Star/delta motor connection	-	
1472	14 ⁶	Inside-delta motor connection	-	
1473	14 ⁷	Motor connection type unknown	-	
1408	15 ⁰	No load	-	
	15 ¹	Reserved = 0	-	
1409	15 ²	Phase failure L1	-	
1410	15 ³	Phase failure L2	-	
1411	15 ⁴	Phase failure L3	-	
1412	15 ⁵	Rotational direction of line frequency right	-	
1413	15 ⁶	Rotational direction of line frequency left	-	
	15 ⁷	Reserved = 0	-	
	16	Reserved = 0	-	
1435	17 ⁰	Output 1 active	-	
1436	17 ¹	Output 2 active	-	
1437	17 ²	Output 3 active	-	
1438	17 ³	Output 4 active	-	
	17 ⁴⁻⁷	Reserved = 0	-	
	18	Reserved = 0	-	

9.12 Data sets (BS)

ID No.	Byte ^{Bit}	Alarm bit	Error No. ^{*)}	Meaning/acknowledgment
Switching/controlling				
1407	19 ⁰	Electronics supply voltage too high		
1470	19 ¹	Ready to start ON for motor		
1414	19 ²	Contact block short-circuited		
1417	19 ³	Bypass element defective		
1418	19 ⁴	Reserved = 0		
1466	19 ⁵	Contact 1 failed		
1467	19 ⁶	Contact 2 failed		
1468	19 ⁷	Contact 3 failed		
Protection function				
1422	20 ⁰	Thermal motor model deactivated		
	20 ¹⁻²	Reserved = 0		
1479	20 ³	Phase angle control failure		
	20 ⁴⁻⁷	Reserved = 0		
1415	21 ⁰	Contact block cooling time active		
1416	21 ¹	Contact block too hot for start		
1482	21 ²	Current measuring range overshoot		
	21 ³⁻⁷	Reserved = 0		
Communication				
357	22 ⁰	Automatic mode (redundant to bit 7.2)		
358	22 ¹	Manual bus mode (redundant to bit 7.3)		
1443	22 ²	Manual bus - PC controls		
359	22 ³	Manual mode local (redundant to bit 7.4)		
1444	22 ⁴	Manual mode local - input controls		
1445	22 ⁵	Manual mode local - HMI controls		
1446	22 ⁶	Manual mode local - PC controls		
	22 ⁷	Reserved = 0		
	23	Reserved = 0		

ID No.	Byte ^{Bit}	Alarm bit	Error No. ^{*)}	Meaning/acknowledgment
Prewarnings				
	24 ⁰⁻¹	Reserved = 0		
1419	24 ²	Prewarning limit - remaining time for tripping undershot		
1420	24 ³	Prewarning limit - motor heating exceeded		
	24 ⁴⁻⁷	Reserved = 0		
	25	Reserved = 0		
	26	Reserved = 0		
	27	Reserved = 0		
	28	Reserved = 0		
	29	Reserved = 0		

*) PROFIBUS DP error numbers

9.12.10 Data set 93 - Writing a command

Structure of the command data set

Byte	Meaning	Note
Header		
0	Coordination	0x20 Writing via C1 channel (PLC) 0x30 Writing via C2 channel (PC) 0x40 Writing 0x40 via device interface (PC)
1 - 3	Reserved	
Command		
4	Number of commands	Value range 1 ... 5 Number of subsequent valid commands
5	Command 1	Sequential No., see table below
6	Command 2	Optional (see table below for coding)
7	Command 3	Optional (see table below for coding)
8	Command 4	Optional (see table below for coding)
9	Command 5	Optional (see table below for coding)

Table 9- 24 Data set 93 - Writing a command

ID No.	Coding	Command	Meaning
1-byte commands			
0	0	Reserved	No function
703	1	Trip reset	Resetting and acknowledging of error messages
713	2	Emergency start ON	Switch on emergency start
714	3	Emergency start OFF	Switch off emergency start
701	6	Factory settings	Restore the basic factory settings of the parameters.
704	7	Reset maximum pointer	The measured values for preventive diagnostics are deleted (= 0).
705	13	Logbook - delete trips	Delete logbook of recorded error causes.
706	14	Logbook - delete events	Delete logbook of recorded alarms and specific actions.
702	9	Restart	Initiate a restart (same as after power ON), e.g., after reassignment of the station address.
707	10	Parameters disabled CPU/master ON	Parameterization by parameterizing master not possible, or its parameters are ignored.
708	11	Parameters disabled CPU/master OFF	Parameterization by parameterizing master is possible.

9.12.11 Data set 94 - Reading measured values

Table 9- 25 Data set 94 - Reading measured values

ID No.	Byte ^{Bit}	Meaning	Value range/[coding]	Increment	Note
Measured values					
504	0	Phase current I_{L1} (%)	0 ... 797 % / [0 ... 255]	3.125%	8-bit current format
505	1	Phase current I_{L2} (%)	0 ... 797 % / [0 ... 255]	3.125%	
506	2	Phase current I_{L3} (%)	0 ... 797 % / [0 ... 255]	3.125%	
507	3	Reserved = 0			
501	4 - 5	Remaining motor cooling time	0 ... 1 800 s / [0 ... 18 000]	0.1 s	
502	6 ⁰⁻⁶	Motor heating	0 ... 200 % / [0 ... 100]	2 %	
	6 ⁷	Asymmetry $\geq 40\%$	No asymmetry [0] Asymmetry ($\geq 40\%$) [1]		
503	7	Asymmetry	0 ... 100 % / [0 ... 100]	1 %	
	8	Reserved = 0			
	10	Reserved = 0			
	11	Reserved = 0			
	12 - 13	Reserved = 0			
	14	Reserved = 0			
508	16	Output frequency	0 ... 100 Hz / [0 ... 200]	0.5 Hz	
	17	Reserved = 0			
	18	Reserved = 0			
	19	Reserved = 0			
509	20	Line frequency	0 ... 100 Hz / [0 ... 200]	0.5 Hz	
	21	Reserved = 0			
510	22 - 23	Line-to-line voltage U_{L1-L2} (rms)	0 ... 1500 V / [0 ... 15000]	0.1 V	
511	24 - 25	Line-to-line voltage U_{L2-L3} (rms)	0 ... 1500 V / [0 ... 15000]	0.1 V	
512	26 - 27	Line-to-line voltage U_{L3-L1} (rms)	0 ... 1500 V / [0 ... 15000]	0.1 V	
513	28 - 31	Phase current I_{L1} (rms)	0 ... 20000 A / [0 ... 2000000]	0.01 A	
514	32 - 35	Phase current I_{L2} (rms)	0 ... 20000 A / [0 ... 2000000]	0.01 A	
515	36 - 39	Phase current I_{L3} (rms)	0 ... 20000 A / [0 ... 2000000]	0.01 A	
516	40 - 41	Electronics supply voltage	0 ... 1500 V / [0 ... 15000]	0.1 V	
517	42	Heatsink temperature	-40 ... 127 °C / [-40 ... 127]	1 °C	
518	43	Contact block heating	0 ... 250 °C / [0 ... 250]	1 °C	
519	44 - 45	Remaining cooling time of contact block	0 ... 1800 s / [0 ... 18000]	0.1 s	
520	46 - 47	Remaining time for tripping of thermal motor model	0 ... 10000 s / [0 ... 10000]	1 s	
521	48 - 51	Output power	0 ... 2147483 W / [0 ... 21474830]	0.1 W	
522	52 - 63	Reserved = 0			

9.12.12 Data set 95 - Reading statistical data

Table 9- 26 Data set 95 - Reading statistical data

ID No.	Byte ^{Bit}	Meaning	Value range/[coding]	Increment	Note
Statistics					
609	0	Motor current I_{max}	0 ... 797 % / [0 ... 255]	3.125%	8-bit current format
	1	Reserved = 0			
608	2	Last tripping current I_A (%)	0 ... 1 000 % / [0 ... 320]	3.125%	
	4	Operating hours - device	0 ... $2^{32}-1$ s / [0 ... $2^{32}-1$]	1 s	
603	8 - 11	Number of starts - motor CW	0 ... $2^{32}-1$ / [0 ... $2^{32}-1$]	1	
604	12 - 15	Number of starts - motor CCW	0 ... $2^{32}-1$ / [0 ... $2^{32}-1$]	1	
605	16 - 17	Number of overload trips	0 ... 65 535 / [0 ... 65 535]	1	
	18	Reserved = 0			
	19	Reserved = 0			
607	20	Motor current I_{max} (rms)	0 ... 20 000 A / [0 ... 2 000 000]	0.01 A	
606	24	Last tripping current I_A (rms)	0 ... 20 000 A / [0 ... 2 000 000]	0.01 A	
602	28	Operating hours - motor	0 ... $2^{32}-1$ s / [0 ... $2^{32}-1$]	1 s	
611	32	Operating hours - motor current 18 ... 49.9 % x $I_{e(max)}$	0 ... $2^{32}-1$ s / [0 ... $2^{32}-1$]	1 s	
612	36	Operating hours - motor current 50 ... 89.9 % x $I_{e(max)}$	0 ... $2^{32}-1$ s / [0 ... $2^{32}-1$]	1 s	
613	40	Operating hours - motor current 90 ... 119.9 % x $I_{e(max)}$	0 ... $2^{32}-1$ s / [0 ... $2^{32}-1$]	1 s	
614	44	Operating hours - motor current 120 ... 1000 % x $I_{e(max)}$	0 ... $2^{32}-1$ s / [0 ... $2^{32}-1$]	1 s	
615	48	Reserved = 0			
616	50	Number of contact block overload trips	0 ... $2^{32}-1$ s / [0 ... $2^{32}-1$]	1	
617	52	Reserved = 0			
618	54	Reserved = 0			
619	56	Reserved = 0			
620	60	Number of electrical braking stops	0 ... $2^{32}-1$ s / [0 ... $2^{32}-1$]	1	
621	64	Number of starts - output 1	0 ... $2^{32}-1$ s / [0 ... $2^{32}-1$]	1	
622	68	Number of starts - output 2	0 ... $2^{32}-1$ s / [0 ... $2^{32}-1$]	1	
623	72	Number of starts - output 3	0 ... $2^{32}-1$ s / [0 ... $2^{32}-1$]	1	
624	76	Number of starts - output 4	0 ... $2^{32}-1$ s / [0 ... $2^{32}-1$]	1	
	80	Reserved = 0			
	84	Reserved = 0			
	88	Reserved = 0			
	89	Reserved = 0			

9.12.13 Data set 96 - Reading the maximum pointer

Table 9- 27 Data set 96 - Reading the maximum pointer

ID No.	Byte ^{Bit}	Meaning	Value range/[coding]	Increment	Note
Maximum pointer					
656	4	Phase current $I_{L1 \min}$ (%)	0 ... 797 % / [0 ... 255]	3.125%	In bypass operation
657	5	Phase current $I_{L2 \min}$ (%)	0 ... 797 % / [0 ... 255]	3.125%	
658	6	Phase current $I_{L3 \min}$ (%)	0 ... 797 % / [0 ... 255]	3.125%	
	7	Reserved = 0			
653	8	Phase current $I_{L1 \max}$ (%)	0 ... 797 % / [0 ... 255]	3.125%	
654	9	Phase current $I_{L2 \max}$ (%)	0 ... 797 % / [0 ... 255]	3.125%	
655	10	Phase current $I_{L3 \max}$ (%)	0 ... 797 % / [0 ... 255]	3.125%	
	11	Reserved = 0			
652	12	Maximum tripping current $I_{A \max}$ (%)	0 ... 1000 % / [0 ... 320]	3.125%	Current during switch-off due to error
651	14	Number of motor overload trips	0 ... 65 535 / [0 ... 65 535]	1	Motor protection, temperature sensor, stalling
659	16	Maximum tripping current $I_{A \max}$ (rms)	0 ... 20 000 A / [0 ... 2 000 000]	0.01 A	Current during switch-off due to error
660	20	Phase current $I_{L1 \min}$ (rms)	0 ... 20 000 A / [0 ... 2 000 000]	0.01 A	In bypass operation
661	24	Phase current $I_{L2 \min}$ (rms)	0 ... 20 000 A / [0 ... 2 000 000]	0.01 A	
662	28	Phase current $I_{L3 \min}$ (rms)	0 ... 20 000 A / [0 ... 2 000 000]	0.01 A	
663	32	Phase current $I_{L1 \max}$ (rms)	0 ... 20 000 A / [0 ... 2 000 000]	0.01 A	
664	36	Phase current $I_{L2 \max}$ (rms)	0 ... 20 000 A / [0 ... 2 000 000]	0.01 A	
665	40	Phase current $I_{L3 \max}$ (rms)	0 ... 20 000 A / [0 ... 2 000 000]	0.01 A	
666	44	Line-to-line voltage $U_{L1 - L2 \min}$ (rms)	0 ... 1500 V / [0 ... 15 000]	0.1 V	Reset to 0 in the event of phase failure or switch-off of main voltage.
667	46	Line-to-line voltage $U_{L2 - L3 \min}$ (rms)	0 ... 1500 V / [0 ... 15 000]	0.1 V	
668	48	Line-to-line voltage $U_{L3 - L1 \min}$ (rms)	0 ... 1500 V / [0 ... 15 000]	0.1 V	
669	50	Line-to-line voltage $U_{L1 - L2 \max}$ (rms)	0 ... 1500 V / [0 ... 15 000]	0.1 V	
670	52	Line-to-line voltage $U_{L2 - L3 \max}$ (rms)	0 ... 1500 V / [0 ... 15 000]	0.1 V	
671	54	Line-to-line voltage $U_{L3 - L1 \max}$ (rms)	0 ... 1500 V / [0 ... 15 000]	0.1 V	
672	56	Electronics supply voltage $U_{NS \min}$ (rms)	0 ... 1500 V / [0 ... 15 000]	0.1 V	Reset to zero at "Power on"
673	58	Electronics supply voltage $U_{NS \max}$ (rms)	0 ... 1500 V / [0 ... 15 000]	0.1 V	
674	60	Maximum heatsink temperature	1 ... -40 °C / [-40 ... 127]	1 °C	
675	61	Maximum contact block heating	0 ... 250 % / [0 ... 250]	1 %	
676	62	Minimum line frequency	0 ... 100 Hz / [0 ... 200]	0.5 Hz	During line failure or phase failure = 0
677	63	Maximum line frequency	0 ... 100 Hz / [0 ... 200]	0.5 Hz	

9.12 Data sets (BS)

ID No.	Byte ^{Bit}	Meaning	Value range/[coding]	Increment	Note
678	64	Operating hours - motor current = 18 ... 49.9 x I _e	0 ... 2 ³² -1 s / [0 ... 2 ³² -1]	1 s	
679	68	Operating hours - motor current = 50 ... 89.9 x I _e	0 ... 2 ³² -1 s [0 ... 2 ³² -1]	1 s	
680	72	Operating hours - motor current = 90 ... 119.9 x I _e	0 ... 2 ³² -1 s [0 ... 2 ³² -1]	1 s	
681	76	Operating hours - motor current = 120 ... 1000 % x I _e		1 s	
682	80	Operating hours - device	0 ... 2 ³² -1 s / [0 ... 2 ³² -1]	1 s	
	84	Reserved = 0			
	85	Reserved = 0			

9.12.14 Data set 100 - Reading the device identification

Table 9- 28 Data set 100 - Reading the device identification

ID No.	Byte ^{Bit}	Value	Note
Header			
	0	Coordination	0x20 Writing via C1 channel (PLC) 0x30 Writing via C2 channel (PC) 0x40 Writing 0x40 via device interface (PC)
	1 - 3	Reserved = 0	
Device identification (TF)			
901	4 - 11	...	Time stamp ^{*)}
902	12 - 31	Siemens AG	Vendor
903	32 - 55		MLFB number
904	56	0x01	Device family: Load feeder
905	57	0x01	Device subfamily: Soft starter
906	58	0x01	Device class: e.g. direct-on-line starter
907	59	0x03	System: SIRIUS 3RW44
908	60	0x46	Function group
909	61	0x00	Reserved = 0
910	62 - 77		Product order code
911	78 - 81	e.g. E001	Hardware version (byte 0 ... byte 3)
912	82	0x00	Ident number (byte 0) (3RW44)
	83	0x00	Ident number (byte 1) (3RW44)
	84	0x80	Ident number (byte 2) (3RW44)
	85	0xDE	Ident number (byte 3) (3RW44)
915	86 - 87	0x00	Reserved = 0
	88 - 95	...	Service number:
	96	0x00	Reserved = 0
	97	0x00	Reserved = 0
	98	0x00	Reserved = 0
	99	0x00	Reserved = 0

^{*)} Time stamp: Time of initialization to factory settings

Table 9- 29 Coding for time stamp

Object name	Id_date								
Object length	8 bytes								
Bits	8	7	6	5	4	3	2	1	
Octet									
1	2 ¹⁵	2 ¹⁴	2 ¹³	2 ¹²	2 ¹¹	2 ¹⁰	2 ⁹	2 ⁸	0 to 59999 milliseconds
2	2 ⁷	2 ⁶	2 ⁵	2 ⁴	2 ³	2 ²	2 ¹	2 ⁰	
3	Res	Res	2 ⁵	2 ⁴	2 ³	2 ²	2 ¹	2 ⁰	0 to 59 minutes
4	SU	Res	Res	2 ⁴	2 ³	2 ²	2 ¹	2 ⁰	0 to 23 hours SU: 0: Normal time; 1: Daylight saving time
5	2 ²	2 ¹	2 ⁰						1 to 7; 1 = Monday, 7 = Sunday
				2 ⁴	2 ³	2 ²	2 ¹	2 ⁰	1 to 31 days
6	Res	Res	2 ⁵	2 ⁴	2 ³	2 ²	2 ¹	2 ⁰	1 to 12 months
7	Res	2 ⁶	2 ⁵	2 ⁴	2 ³	2 ²	2 ¹	2 ⁰	0 to 99 years; 0 = 2000
8	Res	Res	Res	Res	Res	Res	Res	Res	Reserved

9.12.15 Data sets 131, 141, 151 - Technology parameters 2: Reading/writing sets 1, 2, 3

Byte ^{Bit}	Value	Note
Header		
0	Coordination	0x20 Writing via C1 channel (PLC) 0x30 Writing via C2 channel (PC) 0x40 Writing 0x40 via device interface (PC)
1 ... 3	Reserved = 0	

Table 9- 30 Data sets 131, 141, 151 - Technology parameters 2: Reading/writing sets 1, 2, 3

ID No.	Byte ^{Bit}	Meaning	Only in data set 131	Value range/[coding]	Factor
120	4 ... 7	Device functions_2	X		
1	8 ... 11	Device functions_1	X		
130	12	Rated operational current I _e		0 ... 2 000 A [0 ... 200 000]	0.01 A
3	16 ⁰	Load type	X	3-phase [0]	
4	16 ¹	Protection against voltage failure	X	<ul style="list-style-type: none"> • No [0] • Yes [1] 	
	16 ^{2...7}	Reserved = 0			
136	17	Prewarning limit - motor heating	X	0 ... 95 % [0 ... 19]	5 %
5	18 ^{0...2}	Response to overload - thermal motor model	X	<ul style="list-style-type: none"> • Tripping without restart [0] • Tripping with restart [1] • Warning [2] 	
	18 ^{3...7}	Reserved = 0			
6	19 ^{0...4}	Tripping class	X	<ul style="list-style-type: none"> • CLASS 5 (10a) [3] • CLASS 10 [0] • CLASS 15 [4] • CLASS 20 [1] • CLASS 30 [2] • CLASS OFF [15] 	
	19 ^{5...7}	Reserved = 0			
7	20	Recovery time	X	60 ... 1 800 s [2 ... 60]	30 s
8	21	Idle time	X	0 ... 255 s [0 ... 255]	1 s
137	22...23	Prewarning limit - remaining time for tripping	X	0 ... 500 s [0 ... 500]	1 s
10	24 ^{0...1}	Response to overload - temperature sensor	X	<ul style="list-style-type: none"> • Tripping without restart [0] • Tripping with restart [1] • Warning [2] 	
	24 ^{2...3}	Reserved = 0			

9.12 Data sets (BS)

ID No.	Byte ^{Bit}	Meaning	Only in data set 131	Value range/[coding]	Factor
9	24 ^{4...6}	Temperature sensor	X	<ul style="list-style-type: none"> Deactivated [0] Thermoclick [1] PTC type A [2] 	
12	24 ⁷	Temperature sensor monitoring	X	<ul style="list-style-type: none"> No [0] Yes [1] 	
	25...26	Reserved = 0			
15	28	Lower current limit		18.75 ... 100 % [6 ... 32]	3.125%
16	29	Upper current limit		50 ... 150 % [16 ... 48]	3.125%
	30...31	Reserved = 0			
	32 ^{0...5}	Reserved = 0			
14	32 ⁶	Response to current limit violation	X	<ul style="list-style-type: none"> Warning [0] Tripping [1] 	
	32 ⁷	Reserved = 0			
	33 ^{0...1}	Reserved = 0			
140	33 ²	Response to overload - contact block	X	<ul style="list-style-type: none"> Tripping without restart [0] Tripping with restart [1] 	
	33 ^{4...7}	Reserved = 0			
21	34 ^{0...2}	Asymmetry limit value	X	30 ... 60 % [3 ... 6]	10 %
	34 ^{3...5}	Reserved = 0			
20	34 ⁶	Response to asymmetry	X	<ul style="list-style-type: none"> Warning [0] Tripping [1] 	
22	34 ⁷	Response to ground fault	X	<ul style="list-style-type: none"> Warning [0] Tripping [1] 	
	35...44	Reserved = 0			
47	45	Braking torque		20 ... 100 % [4 ... 20]	5 %
	46...47	Reserved = 0			
40	48	Starting voltage		20 ... 100 % [4 ... 20]	5 %
	49	Reserved = 0			
42	50	Current limiting value		<ul style="list-style-type: none"> 3RW44 2, 3, 4: 125 ... 550 % [4 ... 176] 3RW44 5: 125 ... 500 % [40 ... 160] 3RW44 6: 125 ... 450 % [40 ... 144] 	3.125 %
167	51 ^{0...3}	Startup mode		<ul style="list-style-type: none"> Direct [0] Voltage ramp [1] Torque control [2] Motor heating [3] Voltage ramp + current limiting [5] Torque control + current limiting [6] 	

ID No.	Byte ^{Bit}	Meaning	Only in data set 131	Value range/[coding]	Factor
168	51 ^{4...7}	Coasting method		<ul style="list-style-type: none"> Coasting down [0] Voltage ramp [1] Torque control [2] Pump stop [3] DC braking [4] Combined braking [5] 	
35	52...53	Substitute value	X	<p>The "Substitute value" parameter is only relevant if the "Response to CPU/master STOP" parameter has been set to "Switch substitute value", see Process data and process images (Page 181)</p> <ul style="list-style-type: none"> Motor CW 52 [0] Motor CCW (only if 52 [6] active) 52 [1] Trip reset 52 [3] Emergency start 52 [4] Slow speed 52 [6] Output 1 53 [0] Output 2 53 [1] Parameter set bit 0 53 [2] Parameter set bit 1 53 [3] 	
	54...55	Reserved = 0			
	56 ^{0...5}	Reserved = 0			
36	56 ⁶	Group diagnostics	X	<ul style="list-style-type: none"> Disable [0] Enable [1] 	
34	56 ⁷	Response to CPU/master STOP	X	<ul style="list-style-type: none"> Switch substitute value [0] Hold last value [1] 	
	57...75	Reserved = 0			
26	76	Input 1 - action	X	<ul style="list-style-type: none"> No action (default) [0] Manual mode local [6] Emergency start [7] Slow speed [10] Quick stop [11] Trip reset [12] Motor CW with PS1 [16] Motor CCW with PS1 [17] Motor CW with PS2 [18] Motor CCW with PS2 [19] Motor CW with PS3 [20] Motor CCW with PS3 [21] 	

9.12 Data sets (BS)

ID No.	Byte ^{Bit}	Meaning	Only in data set 131	Value range/[coding]	Factor
28	77	Input 2 - (see Input 1 - action)	X		
30	78	Input 3 - (see Input 1 - action)	X		
32	79	Input 4 - (see Input 1 - action)	X		
	80...95	Reserved = 0			
163	96	Output 1 - action	X	<ul style="list-style-type: none"> • No action (default) [0] • Control source PIO DO 1.0 output 1 [1] • Control source PAA-DO 1.1 output 2 [2] • Control source input 1 [6] • Control source input 2 [7] • Control source input 3 [8] • Control source input 4 [9] • Run-up [10] • Operation/bypass [11] • Coasting down [12] • ON time motor [13] • Control command motor ON [14] • Fan [15] • DC brake contactor [16] • Device ON [18] • Group warning [31] • Group fault [32] • Bus fault [33] • Device fault [34] • Ready to start ON for motor [38] 	
164	97	Output 2 - action (see Output 1 - action)	X		
165	98	Output 3 - action (see Output 1 - action)	X		
166	99	Output 4 - action			
	100...111	Reserved = 0			
116	112	Breakaway time		0 ... 2 s [0 ... 200]	0.01 s
117	113	Breakaway voltage		40 ... 100 % [8 ... 20]	5 %
169	114...115	Maximum starting time		0 ... 1 000 s [0 ... 10 000]	0.1 s
170	116...117	Starting time		0 ... 360 s [0 ... 3 600]	0.1 s
171	118...119	Coast-down time		0 ... 360 s [0 ... 3 600]	0.1 s
172	120	Starting torque		10 ... 100 % [2 ... 20]	5 %
118	121	Limiting torque		20 ... 200 % [4 ... 40]	5 %
173	122	Stopping torque		10 ... 100 % [2 ... 20]	5 %
	123	Reserved = 0			
	124	Reserved = 0			

ID No.	Byte ^{Bit}	Meaning	Only in data set 131	Value range/[coding]	Factor
119	125	Motor thermal capacity		1 ... 100 % [1 ... 100]	1 %
	126...129	Reserved = 0			
178	130	Dynamic braking torque		20 ... 100 % [4 ... 20]	5 %
43	131	Slow speed rotation factor: CW		3 ... 21 [3 ... 21]	1
198	132	Slow speed rotation factor: CCW		3 ... 21 [3 ... 21]	1
44	133	Slow speed torque CW		20 ... 100 % [4 ... 20]	5 %
199	134	Slow speed torque CCW		20 ... 100 % [4 ... 20]	5 %
	135...137	Reserved = 0			

Dependencies

- Upper current limit > lower current limit
- DC braking can only be selected when the "DC braking contactor" function is assigned to an output.
- Maximum starting time \geq starting time
- Limiting torque > starting torque

9.12.16 Data sets 132, 142, 152 - Technology parameters 3: Reading/writing sets 1, 2, 3

Byte ^{Bit}	Value	Note
Header		
0	Coordination	0x20 Writing via C1 channel (PLC) 0x30 Writing via C2 channel (PC) 0x40 Writing 0x40 via device interface (PC)
1 - 3	Reserved = 0	

Table 9- 31 Data sets 132, 142, 152 - Technology parameters 3: Reading/writing sets 1, 2, 3

ID No.	ByteBit	Meaning	Value range [coding]	Factor
	4 - 9	Reserved = 0		
104	10 - 11	Rated speed	500 ... 3 600 rpm [500 ... 3 600]	1 rpm
	12 - 18	Reserved = 0		
113	19 - 20	Rated torque	0 ... 65 535 Nm [0 ... 65 535]	1 Nm
	21 - 63	Reserved = 0		

9.12.17 Data set 133 - Technology parameters 4: HMI module

Byte ^{Bit}	Value	Note
Header		
0	Coordination	0x20 Writing via C1 channel (PLC) 0x30 Writing via C2 channel (PC) 0x40 Writing 0x40 via device interface (PC)
1 - 3	Reserved = 0	

Table 9- 32 Data set 133 - Technology parameters 4: HMI module

ID No.	Byte ^{Bit}	Meaning	Value range [coding]	Factor
	4	Reserved = 0		
179	8 ⁰⁻³	Language	<ul style="list-style-type: none"> • English [0] • German [1] • French [2] • Spanish [3] • Italian [4] • Portuguese [5] 	
181	8 ⁴⁻⁷	Lighting brightness	<ul style="list-style-type: none"> • Normal [0] • Delay off [4] • Off [5] 	
180	9	Contrast display	0 ... 100 % [0 ... 20]	5 %
182	10 ⁰⁻³	Response of LEDs to fault	<ul style="list-style-type: none"> • Unchanged [0] • On (1) • Flashing [2] • Flickering [3] 	
183	10 ⁴⁻⁷	Response of LEDs to warning	<ul style="list-style-type: none"> • Unchanged [0] • On (1) • Flashing [2] • Flickering [3] 	
	11	Reserved = 0		
184	12	Reaction time keys	10 ... 100 % [2 ... 20]	5 %
185	13	Auto repeat speed	10 ... 100 % [2 ... 20]	5 %
186	14	Auto repeat time	10 ... 250 ms [2 ... 20]	5 ms
187	15	HMI keys - activity monitoring time	0 ... 1800 s [0 ... 60]	30 s
	16 - 19	Reserved = 0		

9.12.18 Data set 160 - Reading/writing communication parameters

This data set is meant only for devices with direct access to the fieldbus (e.g. PROFIBUS DP) for assignment of communication parameters.

Table 9- 33 Data set 160 - Reading/writing communication parameters

ID No.	Byte ^{Bit}	Communication parameters	Value range [coding]	Increment	Default setting
Header					
200	0	Coordination	0x20 Writing via C1 channel (PLC) 0x30 Writing via C2 channel (PC) 0x40 Writing 0x40 via device interface (PC)		
	1	Reserved1			
	2-3	Reserved2			
Communication					
210	4	Station address	1 ... 126	1	126
211	5	Baud rate	12 000 kBd [0] 6 000 kBd [1] 3 000 kBd [2] 1 500 kBd [3] 500 kBd [4] 187.5 kBd [5] 93.75 kBd [6] 45.45 kBd [7] 19.2 kBd [8] 9.6 kBd [9] Not used [10..14] Automatic baud rate detection [15]		
	6-11	Reserved = 0			

Note

3RW44 soft starters signal the current baud rate while reading. During writing, the value entered is ignored, as the baud rate is always automatically detected by the soft starter.

9.12.19 Data set 165 - Reading/writing comments

You can save any text containing up to 121 characters (max. 121 bytes) in the soft starter, e.g. for system documentation.

Table 9- 34 Data set 165 - Reading/writing comments

Byte ^{Bit}	Communication parameters	Value range [coding]
Header		
0	Coordination	0x20 Writing via C1 channel (PLC) 0x30 Writing via C2 channel (PC) 0x40 Writing 0x40 via device interface (PC)
1	Reserved1	
2 - 3	Reserved2	
Comment		
4 - 124	Comment data	

Typical circuit diagrams

10.1 Connection examples for main and control circuits

10.1.1 3RW44 in a standard circuit with control via keys

3RW44 in a standard circuit with control via keys

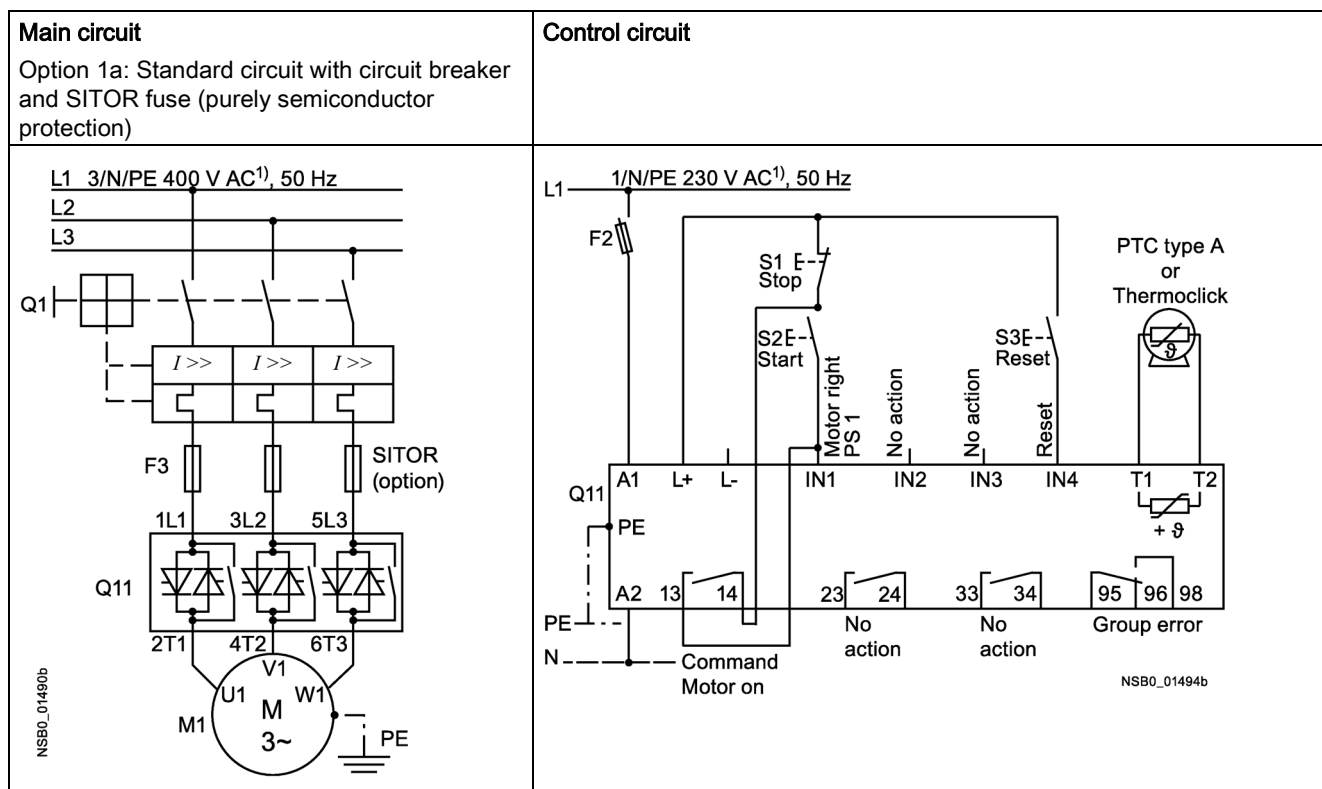

Alternative feeder configuration in the standard circuit

<p>Main circuit</p> <p>Option 1b: standard circuit with full-range fuse (conductor protection and semiconductor protection).</p>	<p>Option 1c:</p> <p>standard circuit with line fuse and SITOR fuse (purely semiconductor protection).</p>

1) For permissible main and control voltage values, refer to chapter Technical data of the power unit (Page 274).

10.1.2 3RW44 in a standard circuit with line contactor and control via PLC

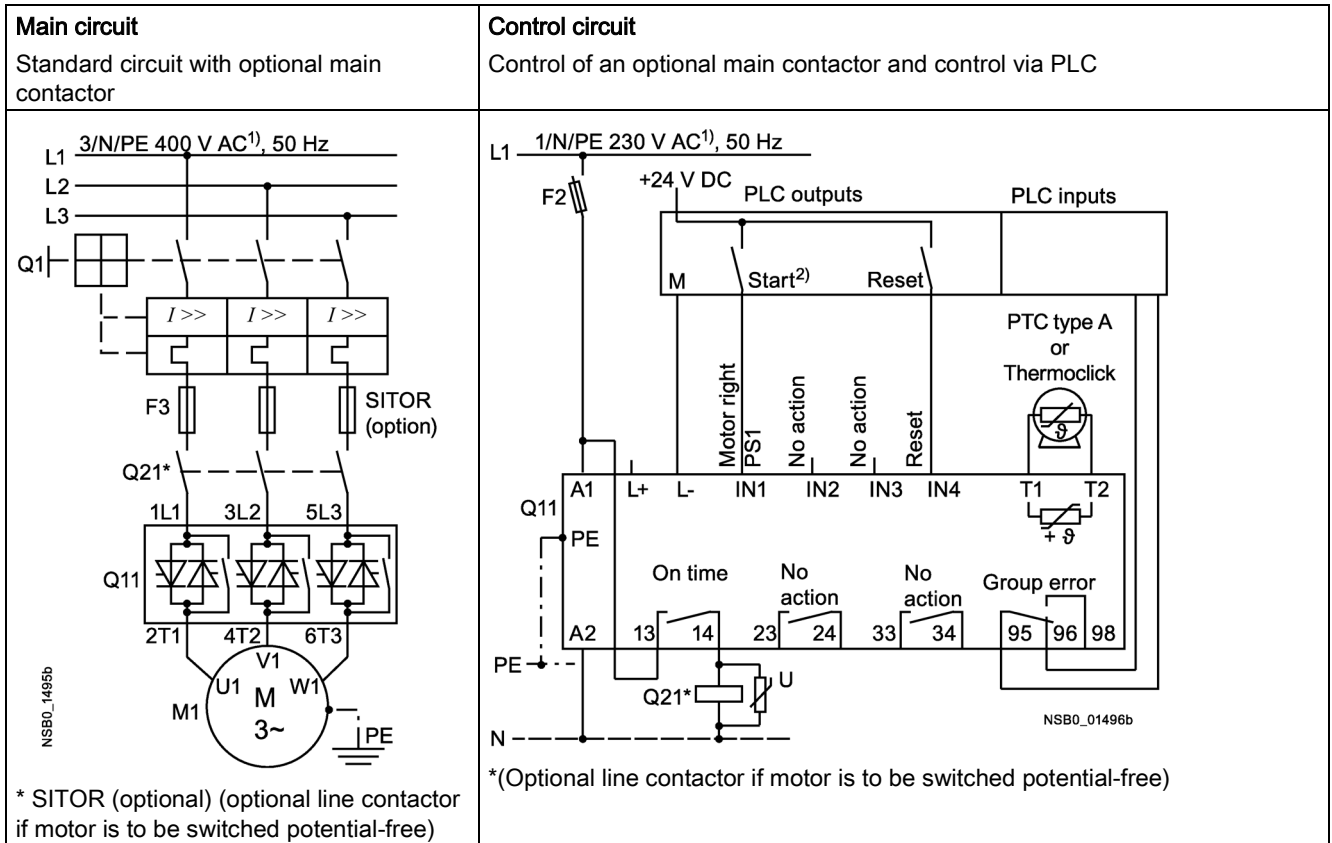

1) For permissible main and control voltage values, refer to chapter Technical data of the power unit (Page 274).

Note

2) Risk of restart

The start command (e.g. issued by the PLC) must be reset when a group fault occurs, because the motor attempts to restart again automatically if a start command is still active following this reset command. This particularly applies to motor protection tripping. For safety reasons, you are advised to integrate the group fault output (terminals 95 and 96) in the controller.

10.1.3 3RW44 in a standard circuit and DC braking stopping function for device types 3RW44 22 to 3RW44 25

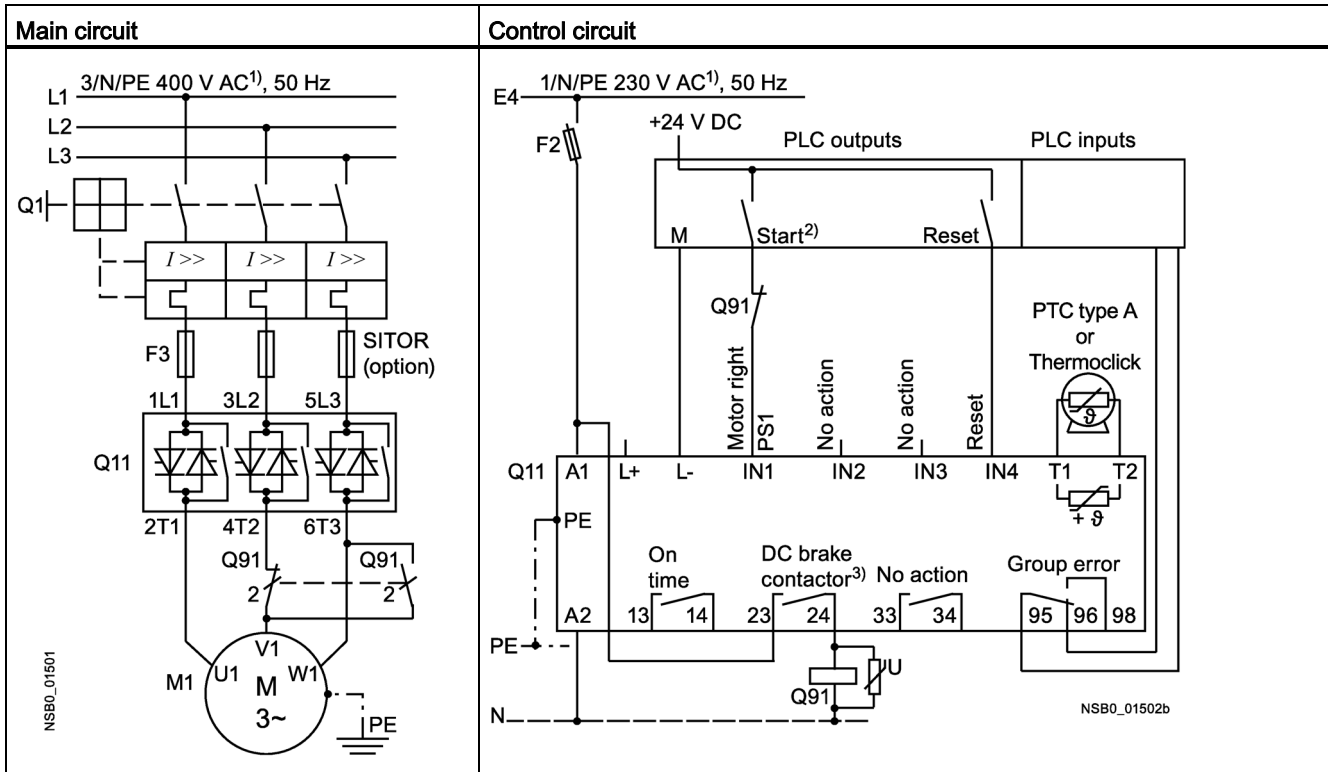

1) For permissible main and control voltage values, refer to chapter Technical data of the power unit (Page 274).

Note

2) Risk of restart

The start command (e.g. issued by the PLC) must be reset prior to issuing a reset command, because the motor attempts to restart again automatically if a start command is still active following this reset command. This particularly applies if the motor protection has tripped. For safety reasons, you are advised to integrate the group fault output (terminals 95 and 96) in the controller.

3) If the "combined braking" stopping function is selected, a braking contactor is not required. A braking contactor must be additionally used if the "DC braking" function is selected.

◆ For types, refer to the "Feeder component layout (standard circuit)" table in chapter Feeder component layout (standard circuit) (Page 286).

The "DC braking" function is recommended for applications with larger centrifugal masses ($J_{load} > J_{motor}$).

Output 2 must be set to "DC braking contactor".

10.1.4 3RW44 in a standard circuit and DC braking stopping function for device types 3RW44 26 to 3RW44 66

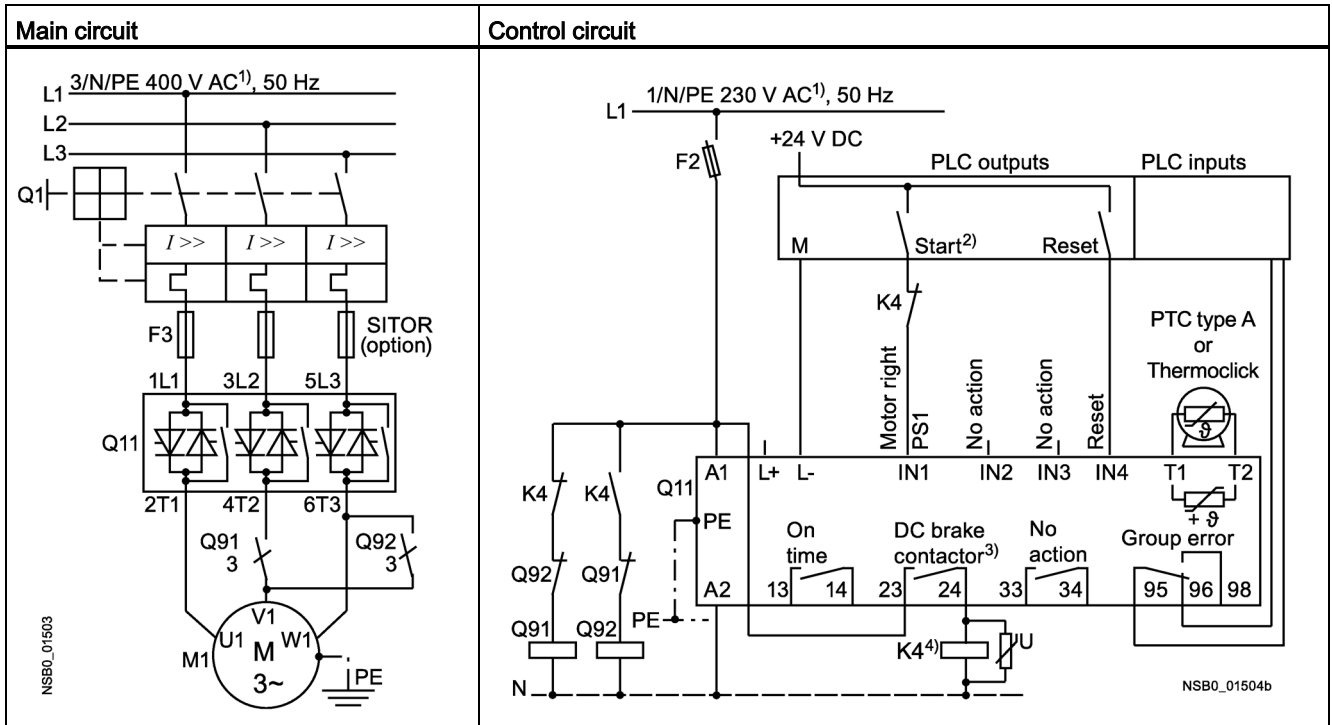

¹⁾ For permissible main and control voltage values, refer to chapter Technical data of the power unit (Page 274).

Note

²⁾ Risk of restart

The start command (e.g. issued by the PLC) must be reset prior to issuing a reset command, because the motor attempts to restart again automatically if a start command is still active following this reset command. This particularly applies if the motor protection has tripped. For safety reasons, you are advised to integrate the group fault output (terminals 95 and 96) in the controller.

³⁾ If the "combined braking" stopping function is selected, a braking contactor is not required. A braking contactor must be additionally used if the "DC braking" function is selected. For types, refer to the "Feeder component layout (standard circuit)" table in chapter Feeder component layout (standard circuit) (Page 286).

The "DC braking" function is recommended for applications with larger centrifugal masses ($J_{load} > J_{motor}$).

Output 2 must be set to "DC braking contactor".

⁴⁾ Auxiliary relay K4, e.g.:

LZS:RT4A4T30 (230 V AC rated control supply voltage),

LZS:RT4A4S15 (115 V AC rated control supply voltage).

10.1.5 3RW44 in an inside-delta circuit

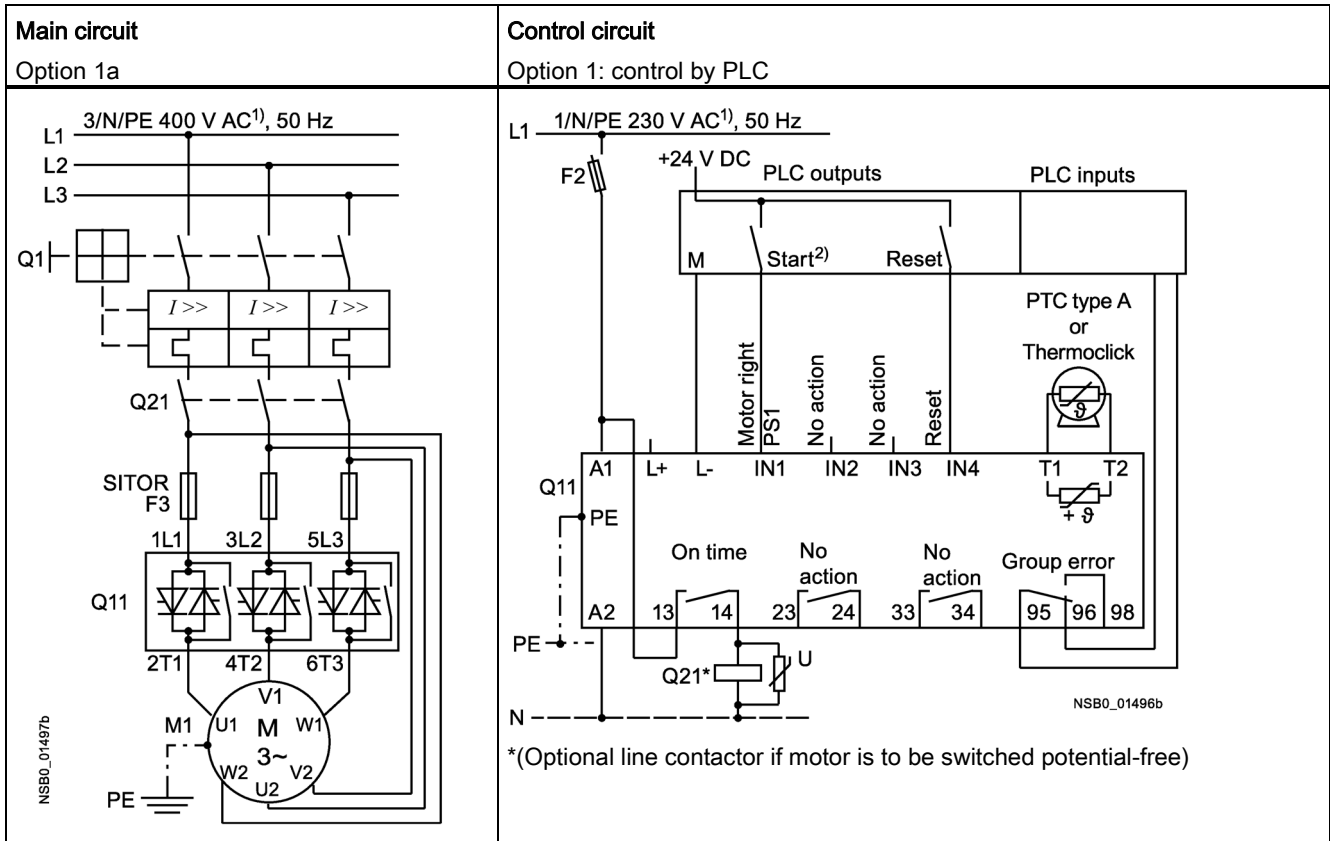

Direction of rotation change in inside-delta circuit

Main circuit

Option 1b

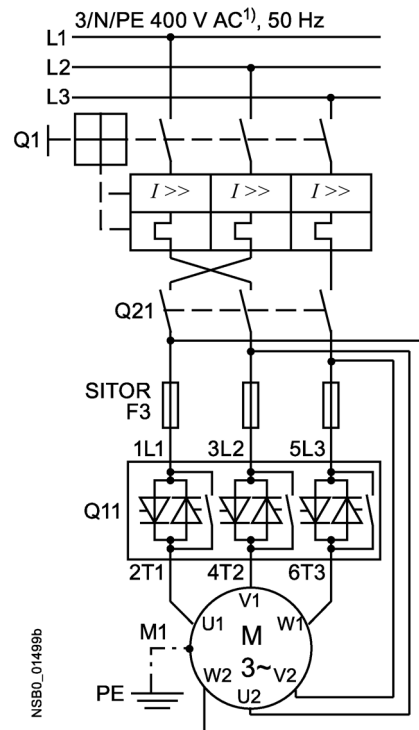

¹⁾ For permissible main and control voltage values, refer to chapter Technical data of the power unit (Page 274).

Note

Please note the wiring suggestions for the inside-delta circuit on the main circuit side. Incorrect connection can result in faults.

Note

Risk of restart

The start command (e.g. issued by the PLC) must be reset prior to issuing a reset command, because the motor attempts to restart again automatically if a start command is still active following this reset command. This particularly applies if the motor protection has tripped.

For safety reasons, you are advised to integrate the group fault output (terminals 95 and 96) in the controller.

10.1.6 3RW44 in a standard circuit and control like a contactor

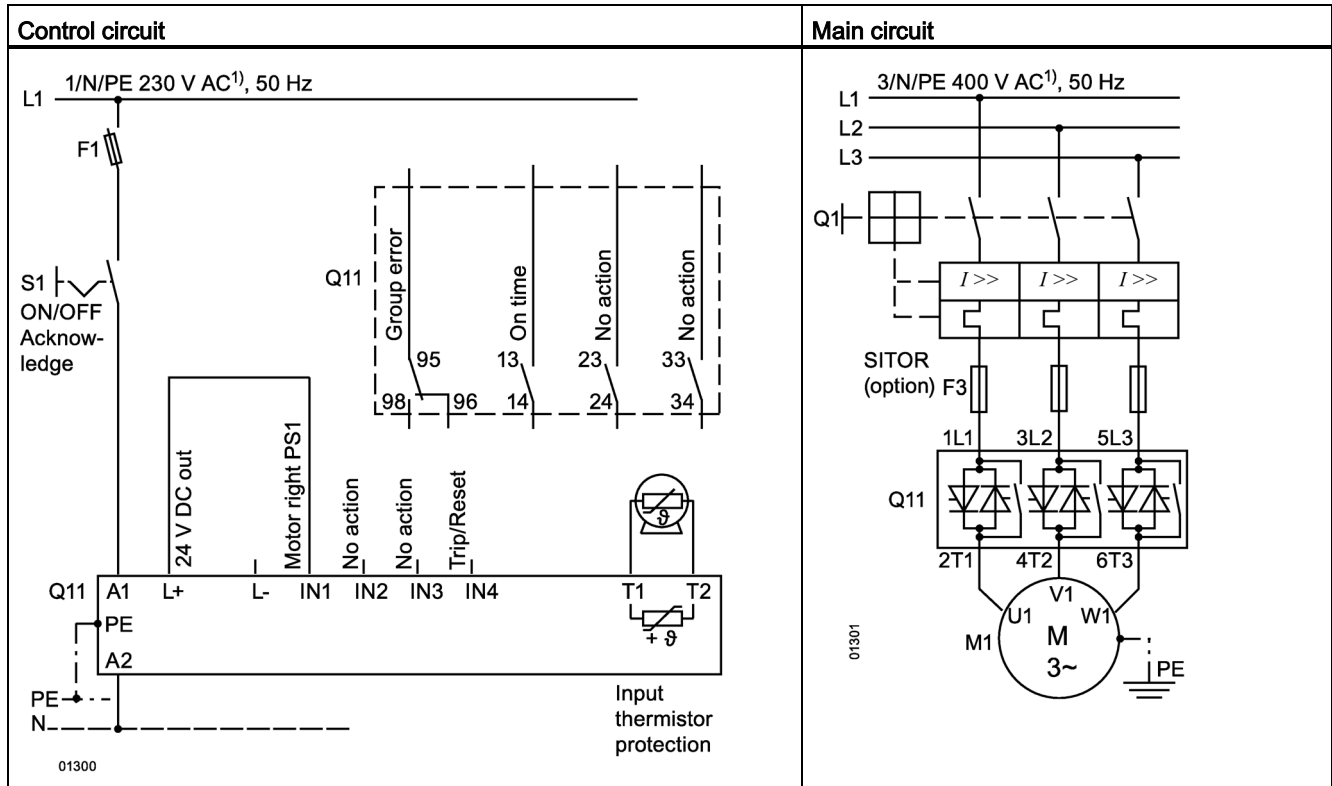

1) For permissible main and control voltage values, refer to chapter Technical data of the power unit (Page 274).

Note

With this circuit type, motor starting may be delayed by up to 5 s after the start command, due to the internal run times of the soft starter. Coasting down is the only possible coasting method.

Note

After the control supply voltage has been switched off and before restarting, the device must be allowed to cool down for at least 30 s, as this influences the effectiveness of the inherent protection of the soft starter.

This type of circuit is not recommended for higher switching frequencies as the integrated fan cannot idle after the soft starter has been switched off, thus reducing the switching frequency specified in the technical data.

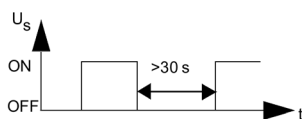

10.1.7 3RW44 in a standard circuit with soft start/stop and additional slow speed function in both directions of rotation with one parameter set

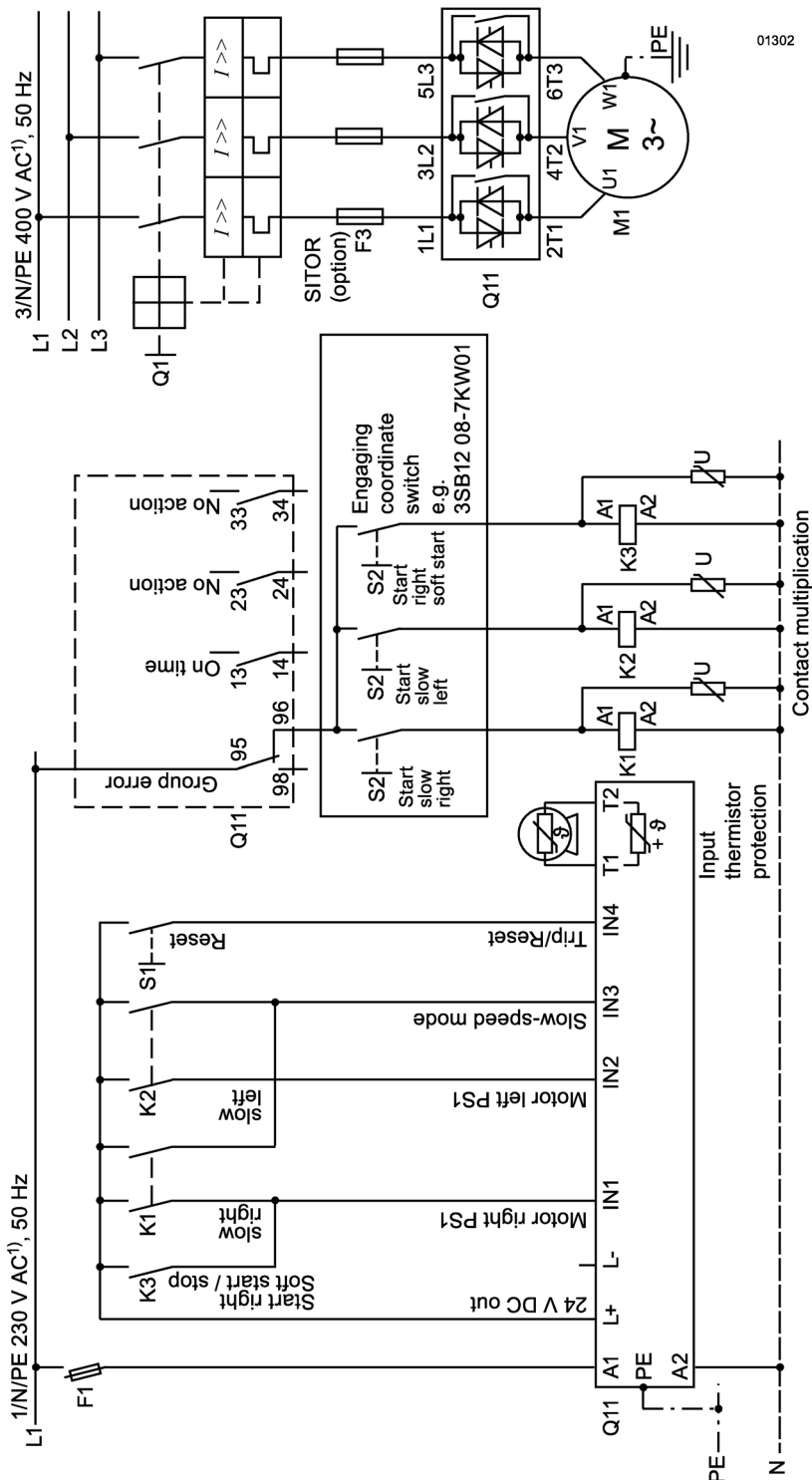

¹⁾ For permissible main and control voltage values, refer to chapter Technical data of the power unit (Page 274).

Note

Parameter assignment

Set the control input functions to::

IN1: Motor CW PS1

IN2: Motor CCW PS1

IN3: Slow-speed mode

IN4: Trip/reset (factory default)

The slow-speed parameters in parameter set 1 must be set. Motor CW means rotation in line phase direction, motor CCW means rotation against the line phase direction.

Note

The slow-speed function is not suitable for continuous operation. The motor can heat up to an inadmissible extent during continuous operation at slow speed.

Note

Risk of restart

The start command must be reset prior to issuing a reset command, because the motor attempts to restart again automatically if a start command is still active following this reset command. This particularly applies if the motor protection has tripped.

K1, K2, K3 = relays for contact multiplication, e.g. for 230 V AC operation: 3RS 1800-1BP00

10.1.8 Control via @PROFIBUS with switchover to manual local operation (e.g. on the control cabinet)

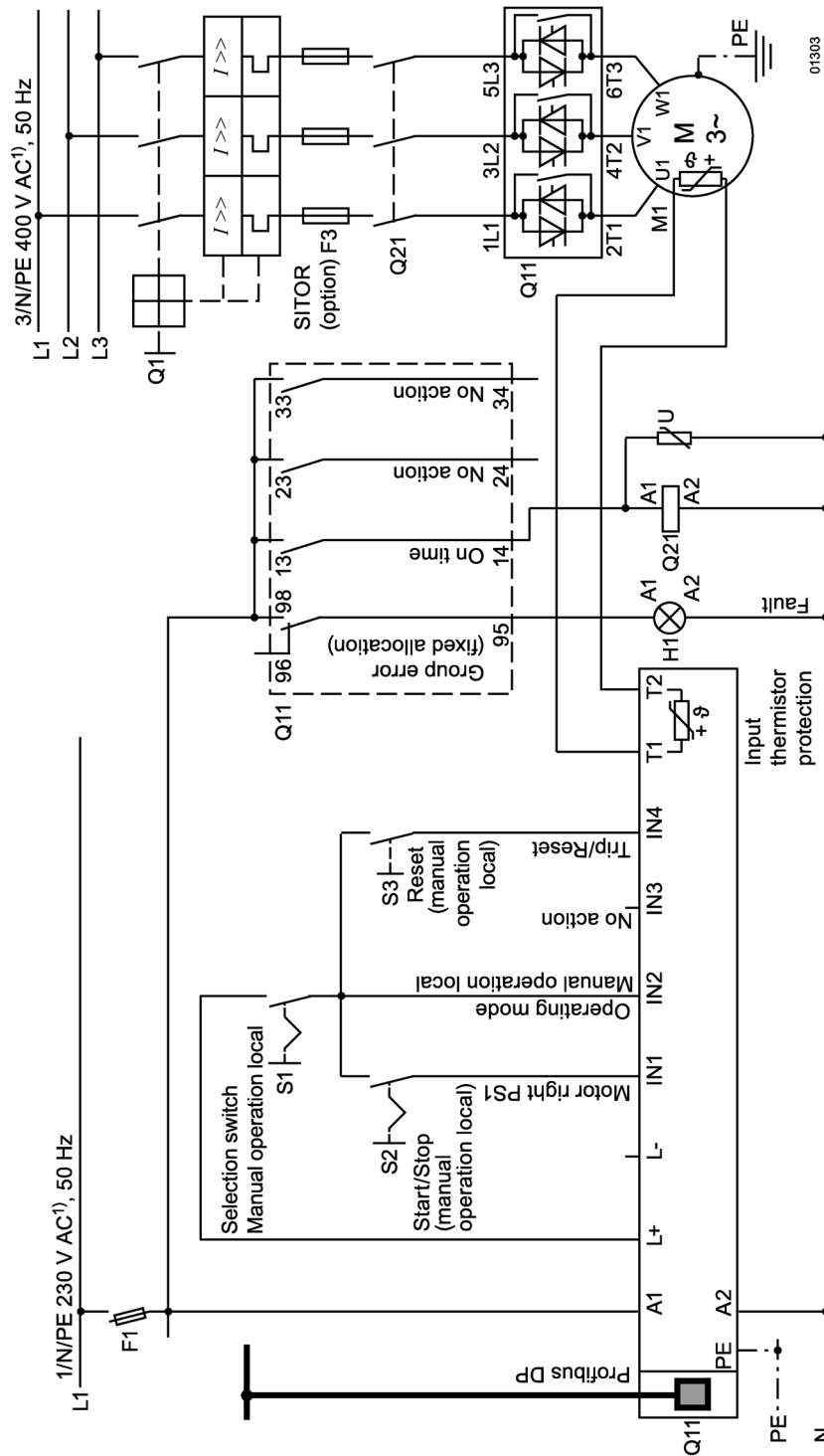

1) For permissible main and control voltage values, refer to chapter Technical data of the power unit (Page 274).

10.1.9 3RW44 in a standard circuit and reversing operation via main contactors with one parameter set without soft stopping

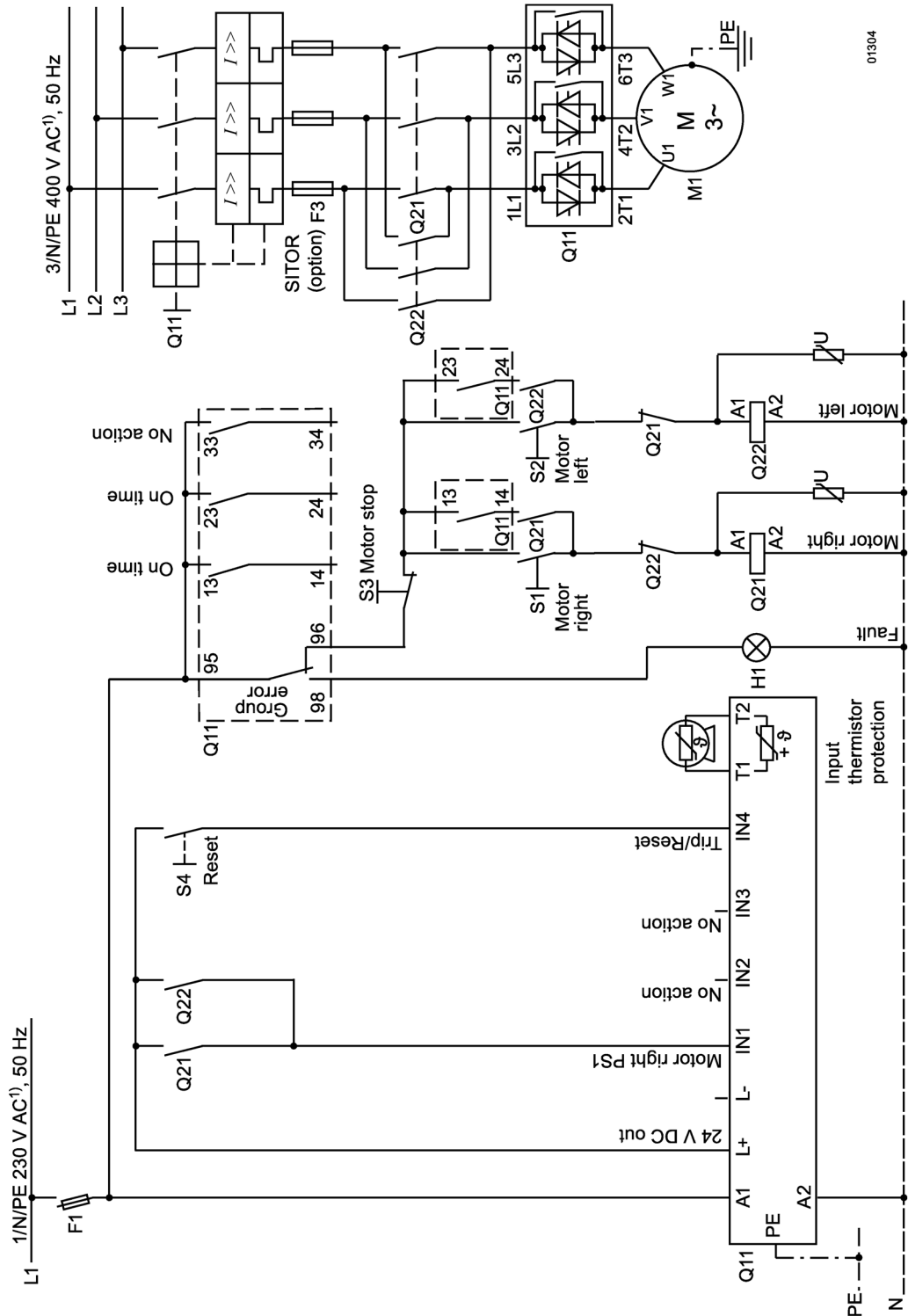

01304

1) For permissible main and control voltage values, refer to chapter Technical data of the power unit (Page 274).

Note

The "Coasting down" coasting method must be set on the 3RW44.

10.1.10 Reversing operation with soft stopping

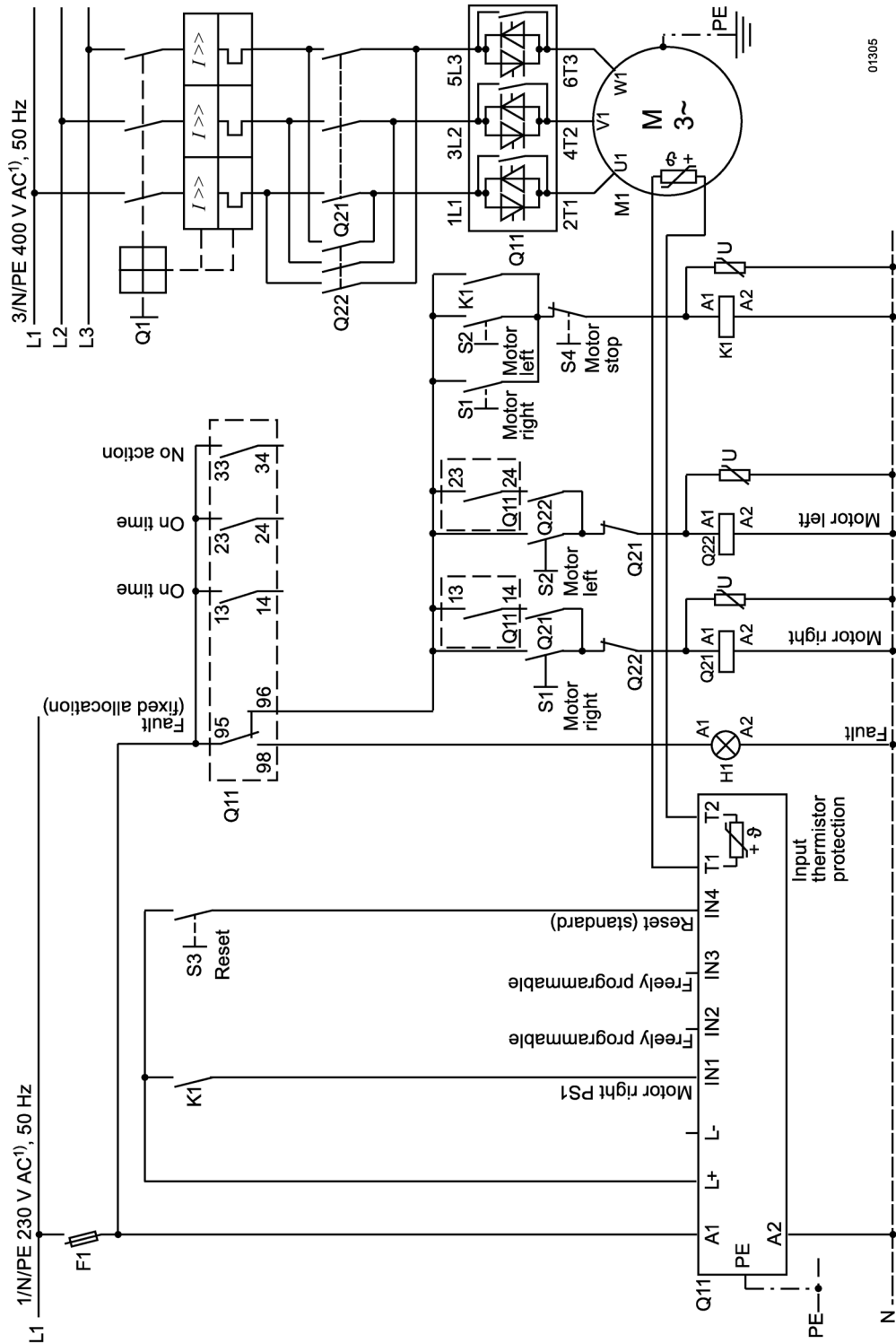

01305

1) For permissible main and control voltage values, refer to chapter Technical data of the power unit (Page 274).

10.1.11 Soft starter for pole-changing motor with separate windings and 2 parameter sets

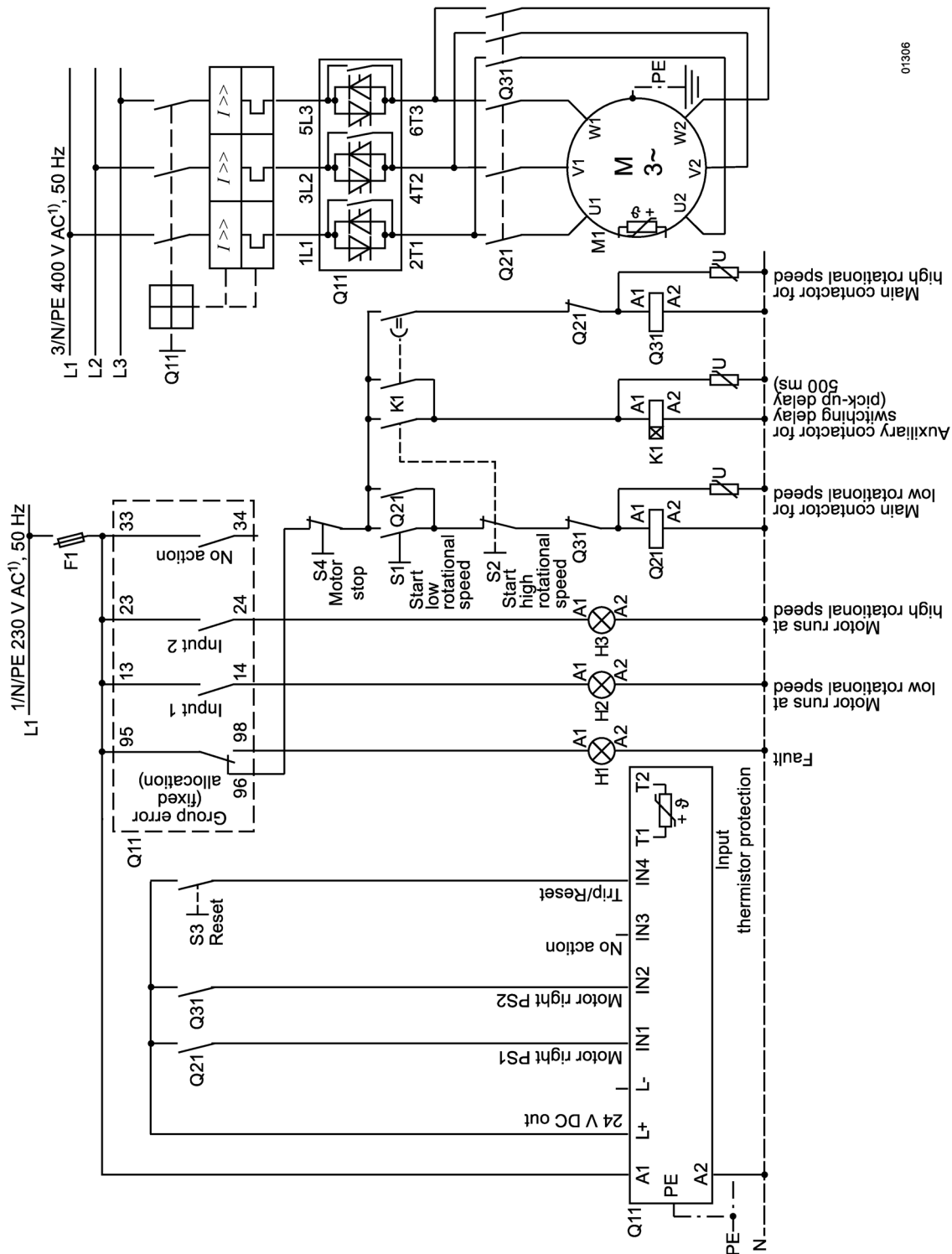

01306

¹⁾ For permissible main and control voltage values, refer to chapter Technical data (Page 268).

Note

The "Coasting down" coasting method must be set on the 3RW44.

10.1.12 Soft starter for Dahlander motors with 2 parameter sets

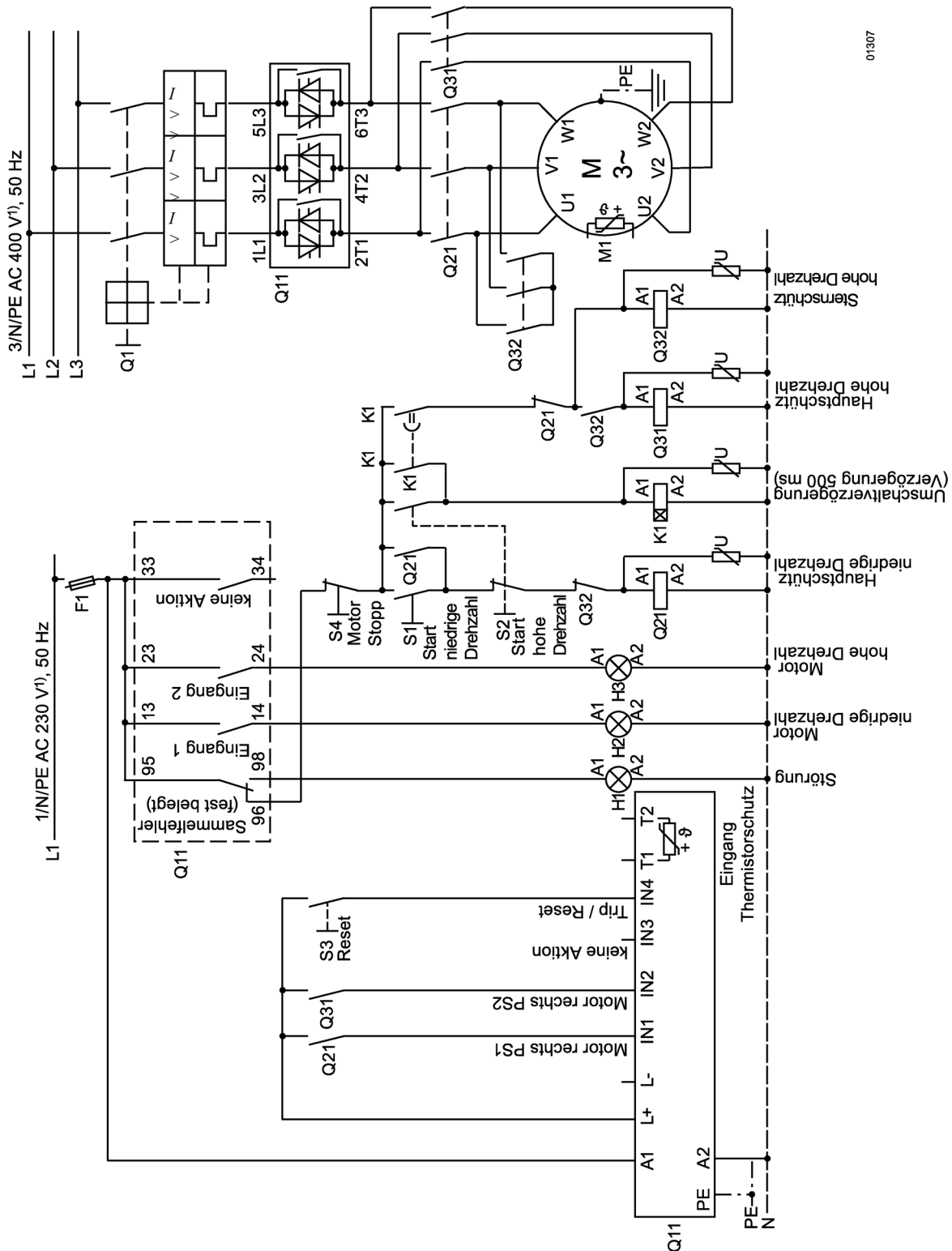

01307

1) For permissible main and control voltage values, refer to chapter Technical data of the power unit (Page 274).

Note

The "Coasting down" coasting method must be set on the 3RW44.

10.1.13 Parallel starting of 3 motors

Control circuit

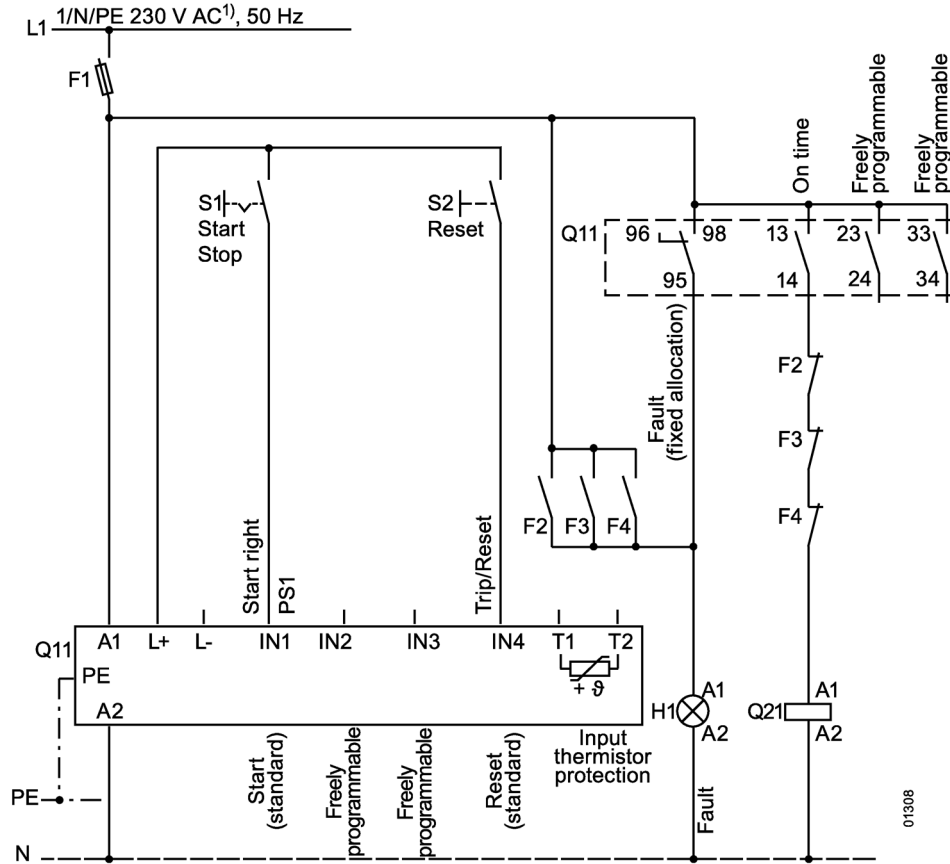

¹⁾ For permissible main and control voltage values, refer to chapter Technical data of the power unit (Page 274).

Note

The rated output of the 3RW44 to be configured must be at least as high as the sum of the motor's rated outputs.

The loads should have similar mass moments of inertia and torque curves.

Parallel starting of 3 motors

Main circuit

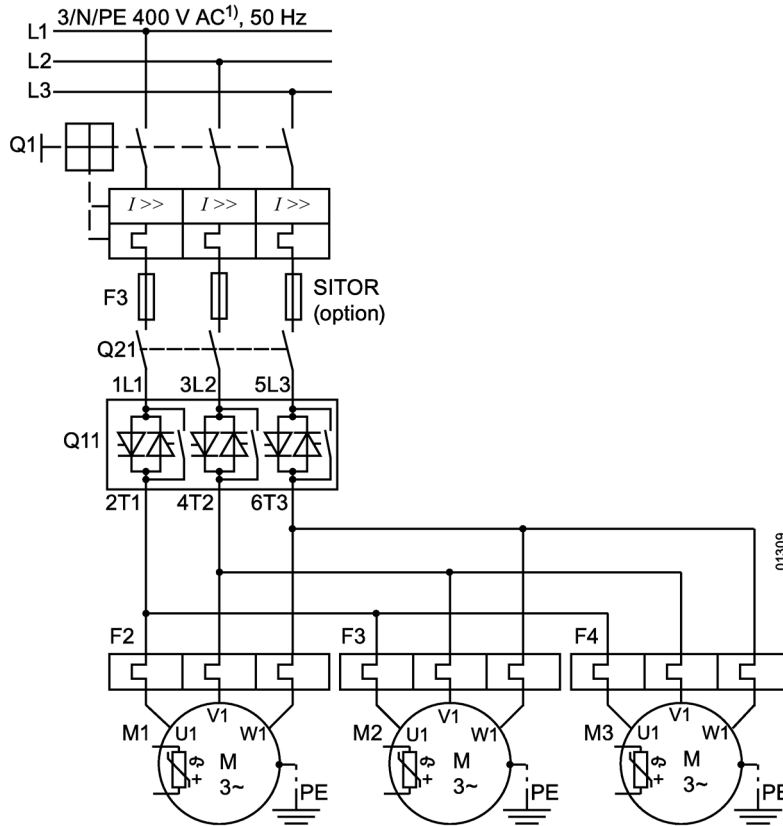

1) For permissible main and control voltage values, refer to chapter Technical data of the power unit (Page 274).

Note

The rated output of the 3RW44 to be configured must be at least as high as the sum of the motor's rated outputs.

The loads should have similar mass moments of inertia and torque curves.

10.1.14 Soft starter for serial starting with 3 parameter sets

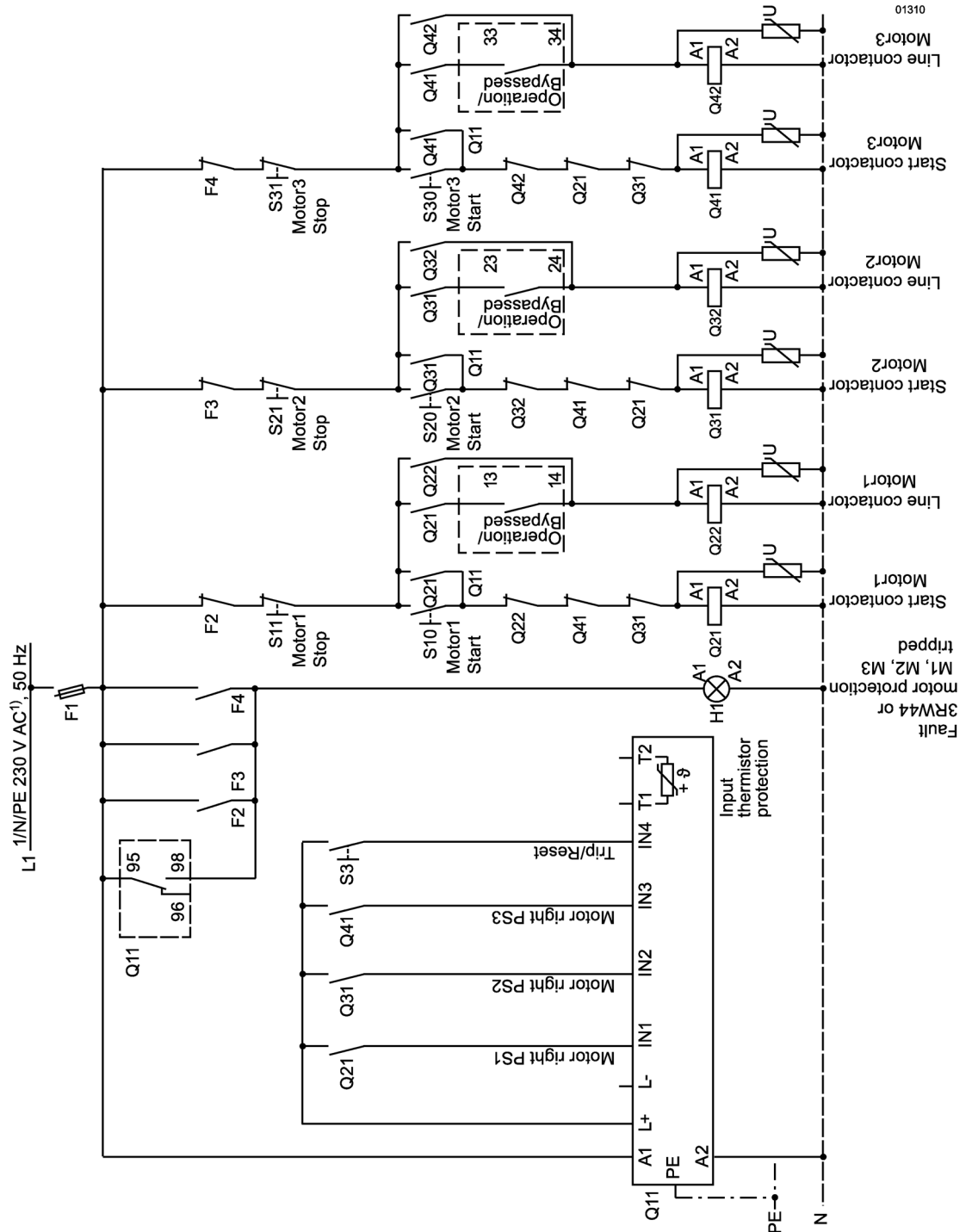

1) For permissible main and control voltage values, refer to chapter Technical data of the power unit (Page 274).

Note

The "Coasting down" coasting method must be set on the 3RW44.

Note

In the case of increased operating sequences, the 3RW44 should be dimensioned at least one capacity level higher than the highest connected motor output.

10.1.15 Soft starter for serial starting with 3 parameter sets (deactivate soft stop and 3RW44 motor protection)

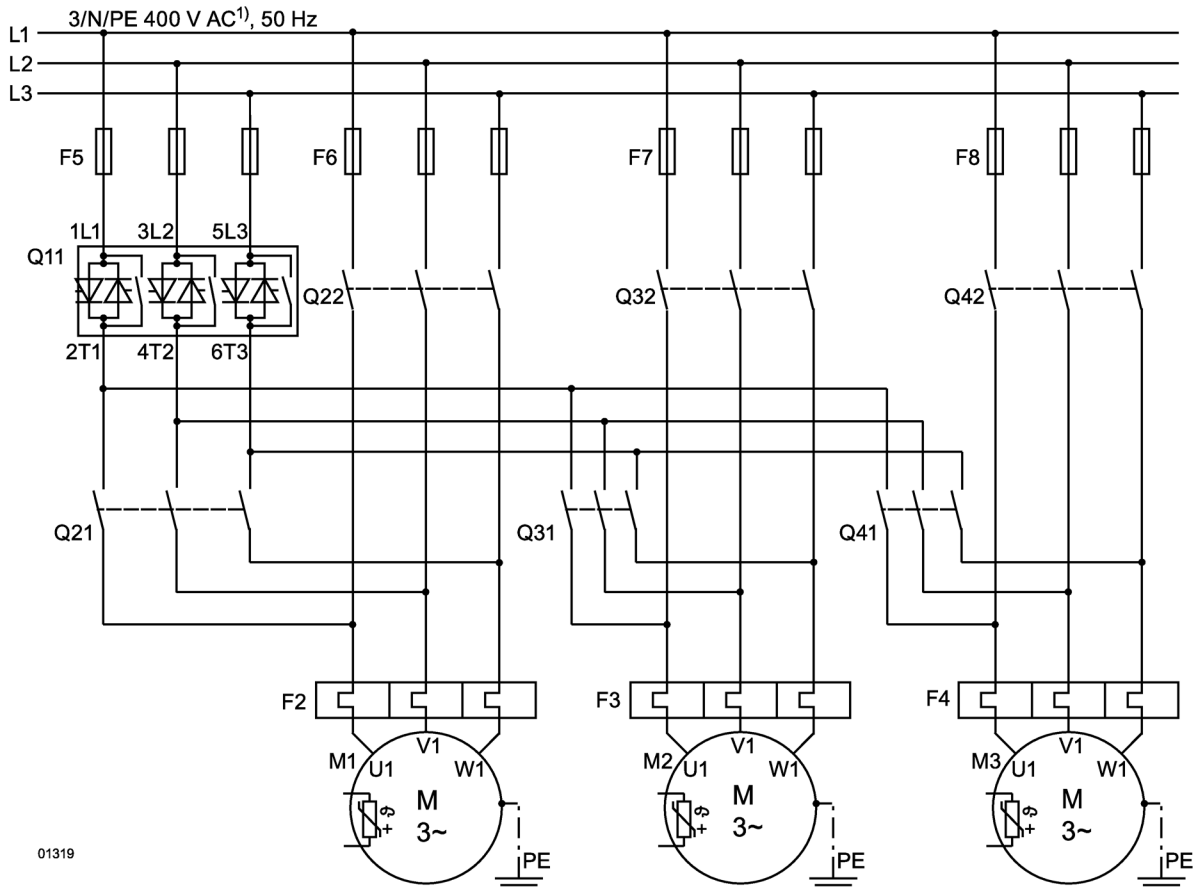

¹⁾ For permissible main and control voltage values, refer to chapter Technical data of the power unit (Page 274).

Note

In the case of increased operating sequences, the 3RW44 should be dimensioned at least one capacity level higher than the highest connected motor output.

Note

The "Coasting down" coasting method must be set on the 3RW44.

10.1.16 Soft starter for activation of a motor with a magnetic fixing brake

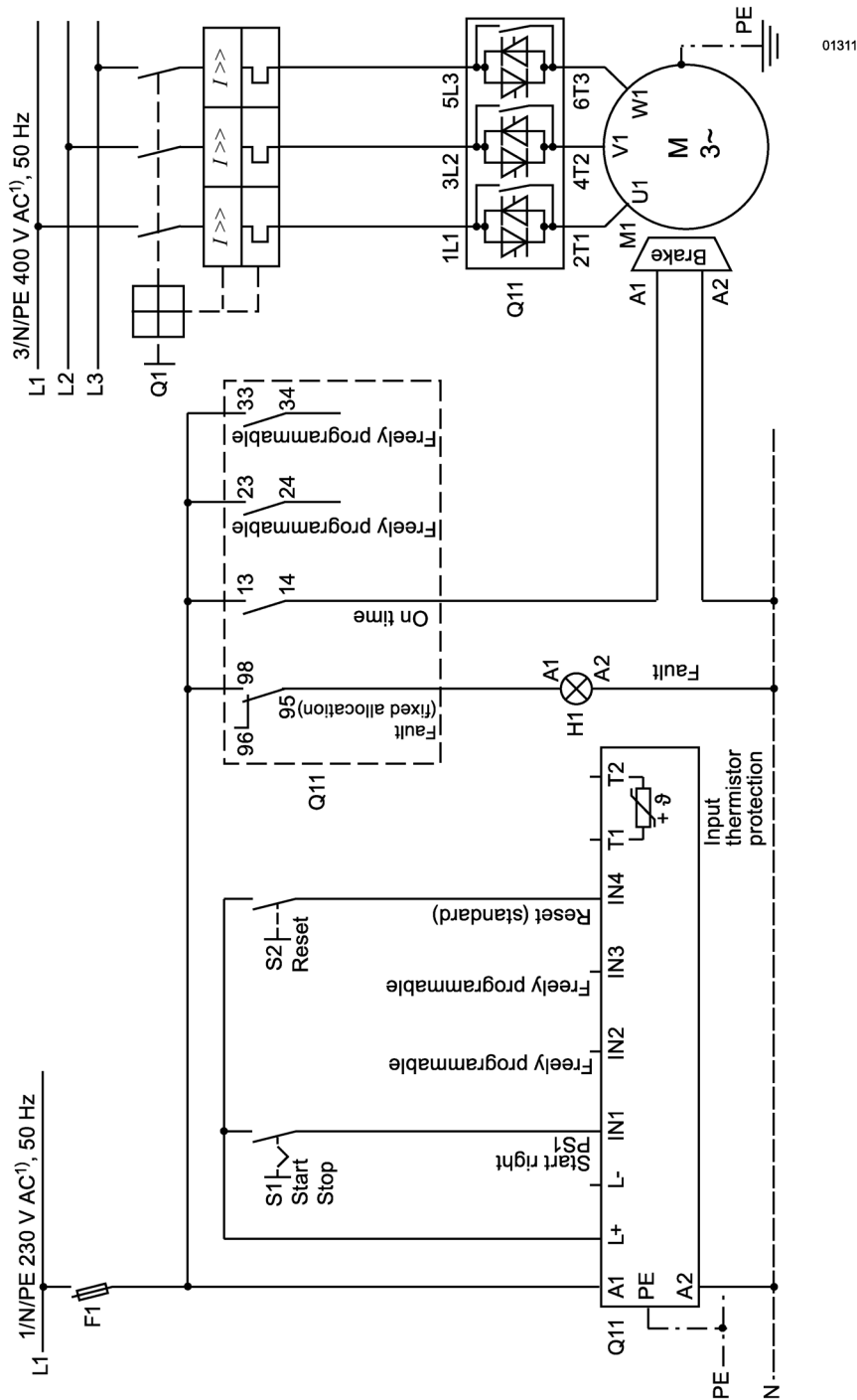

1) For permissible main and control voltage values, refer to chapter Technical data of the power unit (Page 274).

10.1.17 Safe disconnection according to IEC 62061 (SIL) and/or ISO 13849-1 (PL)

The 3RW soft starter is used for functional switching. Safe disconnection can also be realized, for example, with a 3SK1 safety relay and power contactors.

The examples given in the FAQ

(<https://support.industry.siemens.com/cs/ww/en/view/67474130>) describe possible configurations based on various safety requirements.

10.1.18 Soft starter with direct-on-line starting (DOL) as emergency start

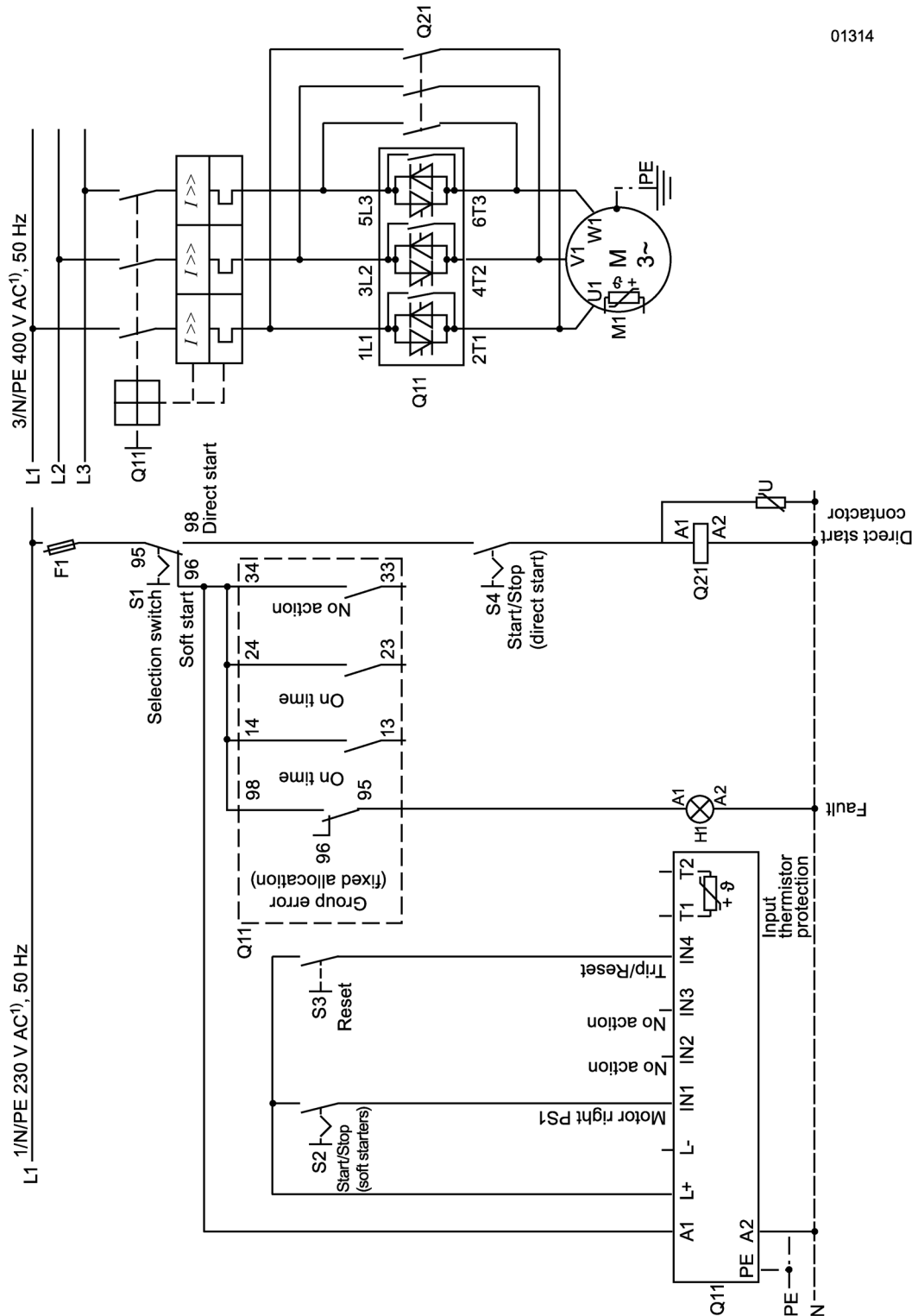

01314

1) For permissible main and control voltage values, refer to chapter Technical data of the power unit (Page 274).

10.1.19 Soft starter with star-delta starter as emergency start (3RW44 in a standard circuit)

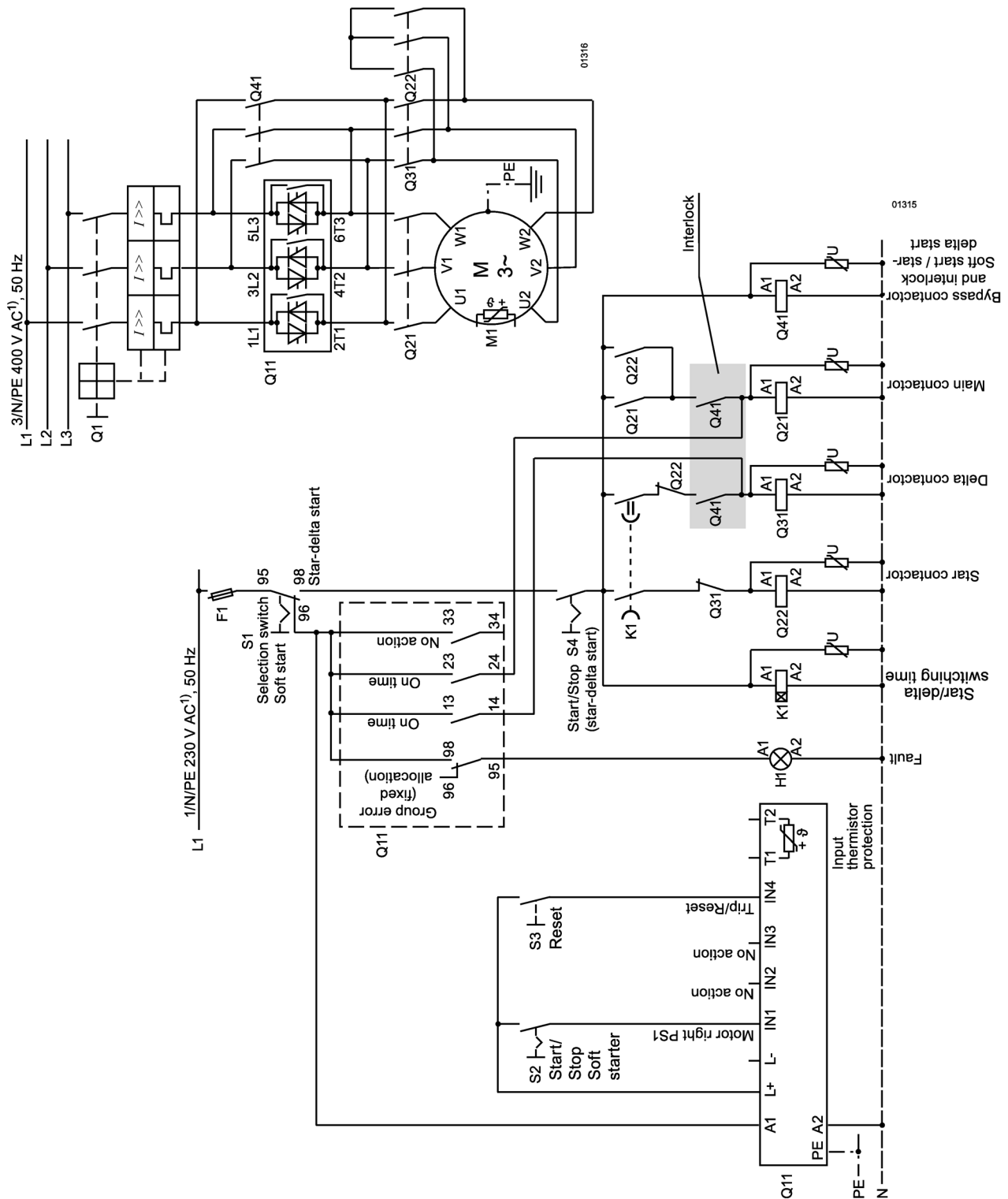

1) For permissible main and control voltage values, refer to chapter Technical data of the power unit (Page 274).

10.1.20 Soft starter and frequency converter on one motor

01318

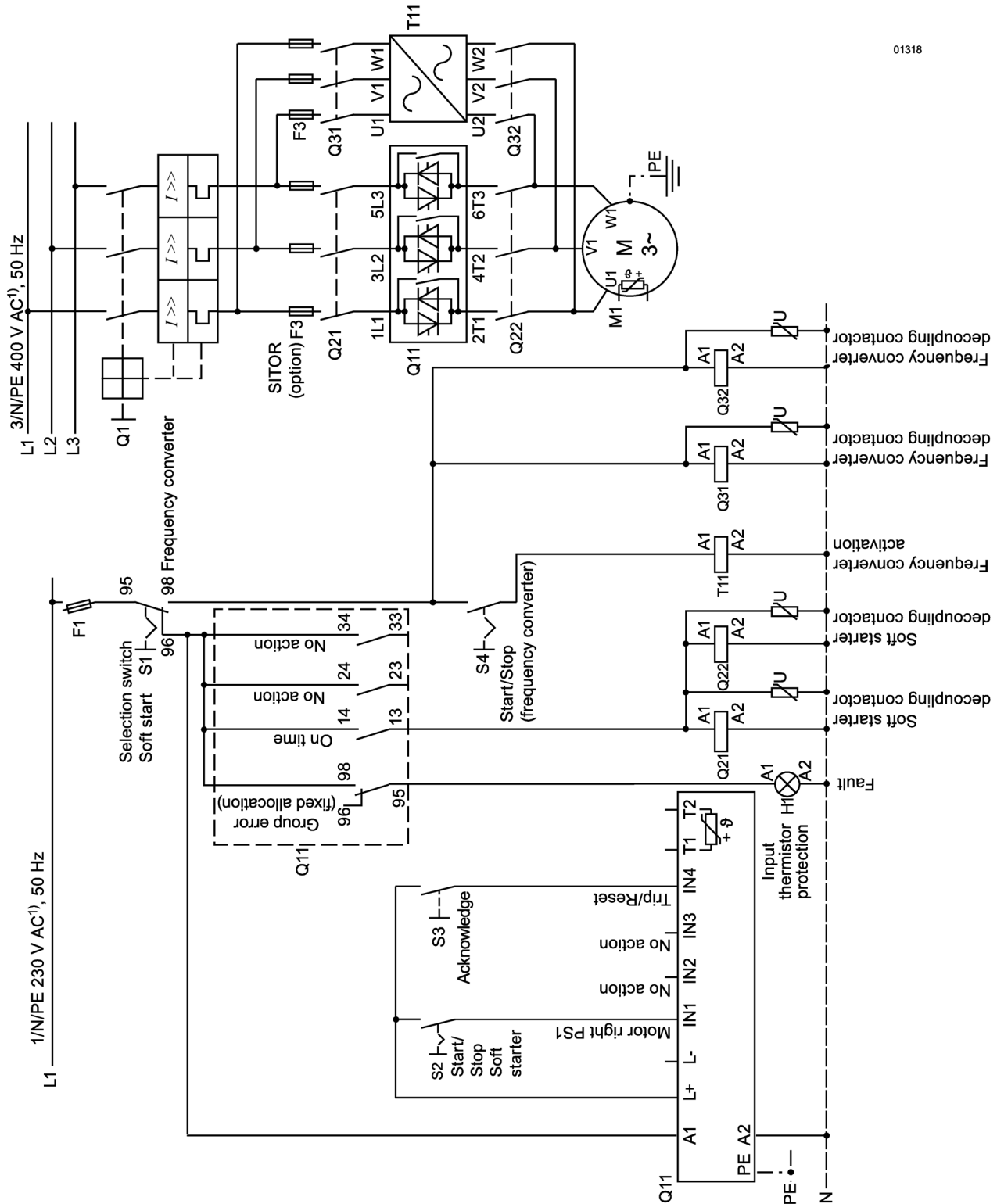

1) For permissible main and control voltage values, refer to chapter Technical data of the power unit (Page 274).

General technical data

11.1 Menu structure

Menu: measured values display	
Phase voltages	UL1N
	UL2N
	UL3N
Line-to-line voltages	UL1-L2
	UL2-L3
	UL3-L1
Blocking voltages	ULT1
	ULT2
	ULT3
Phase currents	IL1
	IL2
	IL3
Power	
Line frequency	
Supply voltage	
Heatsink temperature	
Motor heating	
Remaining time for tripping	
Standard display off	

Menu: status display			
Device status			
Active parameter set	Parameter set 1		
	Parameter set 2		
	Parameter set 3		
Type of connection	Unknown/defective		
	Wye / delta		
	Inside-delta		
Direction of rotation	Unknown		
	CW		
	CCW		
Inputs	Status - inputs		
	Input 1 - action	No action	
		Manual mode local	
		Emergency start	
		Slow speed	
		Quick stop	
		Trip reset	
		Motor CW PS1	
		Motor CCW PS1 ^{*)}	
		Motor CW PS2	
		Motor CCW PS2 ^{*)}	
	Motor CW PS3		
	Motor CCW PS3 ^{*)}		
	Input 2 - action [...]		
Input 3 - action [...]			
Input 4 - action [...]			

Menu: status display		
Device status		
Outputs	Status - outputs	
	Output 1 - action	No action
		PIQ output 1
		PIQ output 2
		Input 1
		Input 2
		Input 3
		Input 4
		Startup
		Operation/bypass
		Run down
		ON time
		Command motor On
		DC braking contactor
		Group warning
	Group fault	
	Bus fault	
Device fault		
Power on		
Ready to start		
	Output 2 - action [...]	
	Output 3 - action [...]	
	Output 4 - action [...]	
Article number		
Firmware information	Version	
	Date	

*) Only possible in combination with slow speed

Menu: Settings		Factory settings	Customer settings
Parameter set 1			
Motor 1	Rated operational current I_e		MLFB-dependent
	Rated torque		0
	Rated speed		1500
	Copy motor data to PS2 + 3		
Starting settings	Startup mode	Voltage ramp	
		U + current limiting	x
		Torque control	
		M + current limiting	
		Direct	
	Motor heating		
	Starting voltage		30 %
	Starting torque		10 %
	Limiting torque		150 %
	Starting time		10 s
	Maximum starting time		0/deactivated
	Current limiting value		400 %
	Breakaway voltage		40 %
	Breakaway time		0 ms
Motor thermal capacity		20 %	
Coasting settings	Coasting method	Coasting down	x
		Torque control	
		Pump stop	
		DC braking	
		Combined braking	
	Coast-down time		10 s
	Stopping torque		10 %
	Dynamic braking torque		50 %
	DC braking torque		50 %
Slow speed parameters	Slow speed factor CW		7
	Slow torque CW		50 %
	Slow speed factor CCW		
	Slow torque CCW		50 %
Current limits	Lower current limit		18.75 %
	Upper current limit		112.50 %

Menu: Settings		Factory settings	Customer settings
Parameter set 2 [...]			
Parameter set 3 [...]			
Inputs			
Input 1 - action	No action		
	Manual mode local		
	Emergency start		
	Slow speed		
	Quick Stop		
	Trip reset		
	Motor CW PS1		x
	Motor CCW PS1 ^{*)}		
	Motor CW PS2		
	Motor CCW PS2 ^{*)}		
	Motor CW PS3		
Motor CCW PS3 ^{*)}			
Input 2 - action [...]		No action	
Input 3 - action [...]		No action	
Input 4 - action [...]		Trip reset	
Outputs			
Output 1 - action	No action		
	PIQ output 1		
	PIQ output 2		
	Input 1		
	Input 2		
	Input 3		
	Input 4		
	Startup		
	Operation/bypass		
	Run down		
	ON time		x
	Command motor On		
	DC braking contactor		
	Group warning		
	Group fault		
	Bus fault		
	Device fault		
Power on			
Ready to start			
Output 2 - action [...]		No action	
Output 3 - action [...]		No action	

11.1 Menu structure

Menu: Settings		Factory settings	Customer settings
Motor protection			
Tripping class	None		
	CLASS 5 (10a)		
	CLASS 10	x	
	CLASS 15		
	CLASS 20		
	CLASS 30		
Current asymmetry limit value		40 %	
Prewarning limit - remaining time for tripping		0 s	
Prewarning limit - motor heating		80 %	
Idle time		0 s	
Recovery time		60 s	
Protection against voltage failure	No		
	Yes	x	
Temperature sensor	Deactivated	x	
	Thermoclick		
	PTC type A		
Display			
Language	English	x	
	Deutsch		
	Français		
	Español		
	Italiano		
	Português		
	Nederlands		
	Ελληνικά		
	Türkçe		
	Русский		
	中文		
Contrast		50 %	
Lighting	Brightness	Lighting on	x
		Time delayed off	
		Lighting off	
	Response to fault	Unchanged	
		On	
		Flashing	
		Flicker	x
	Response to warning	Unchanged	
		On	
		Flashing	x
Flicker			

Menu: Settings			Factory settings	Customer settings
Reaction time keys			60 %	
Autorepeat	Time		80 ms	
	Velocity		80 %	
Activity monitoring time			30 s	
Response to ...				
Overload - therm. motor model	Tripping without restart		x	
	Tripping with restart			
	Warning			
Overload - temperature sensor	Tripping without restart		x	
	Tripping with restart			
	Warning			
Current limit violation	Warning		x	
	Tripping			
Overload - contact block	Tripping without restart		x	
	Tripping with restart			
Asymmetry	Warning			
	Tripping		x	
Ground fault	Warning		x	
	Tripping			
Name				
Name				
Fieldbus				
Fieldbus interface	Off		x	
	On			
Group diagnostics	Disable		x	
	Enable			
Response to CPU/master STOP	Substitute value		x	
	Last value			
Station address			126	
Baud rate				

11.1 Menu structure

Menu: Settings		Factory settings	Customer settings
Substitute value	Motor CW		
	Motor CCW		
	Slow speed		
	Emergency start		
	Output 1		
	Output 2		
	Parameter set 1		
	Parameter set 2		
	Parameter set 3		
	Disable quick stop		
Parameters disabled CPU/Master	Off	x	
	On		
Saving options			
Save settings			
Restoring settings			
Factory settings			

*) Only possible in combination with slow speed

Menu: Motor control		
Keys control motor	Key control	Activate
		Deactivate
	Selecting the parameter set	Parameter set 1
		Parameter set 2
		Parameter set 3
	Execute control function	Motor CW
		Motor CCW ^{*)}
		Slow speed
		Emergency start
		Output 1
Output 2		
Control via inputs	Control inputs	Activate
		Deactivate
Standard control	Automatic/None	
	Inputs	
	Keys	

*) Only possible in combination with slow speed

Menu: Statistics		
Logbooks	Device fault	
	Trips	
	Events	
Maximum pointer	Currents (%)	Phase current L1 min
		Phase current L2 min
		Phase current L3 min
		Phase current L1 max
		Phase current L2 max
		Phase current L3 max
	Currents (rms)	Phase current L1 min
		Phase current L2 min
		Phase current L3 min
		Phase current L1 max
		Phase current L2 max
		Phase current L3 max
	Line-to-line voltages	UL1 - L2 min (rms)
		UL2 - L3 min (rms)
		UL3 - L1 min (rms)
		UL1 - L2 max (rms)
		UL2 - L3 max (rms)
		UL3 - L1 max (rms)
	Maximum operating current I_A (%)	
	Maximum operating current I_A (rms)	
	Number of overload trips	
Minimum line frequency		
Maximum line frequency		
Max. heat sink temperature		
Max. contact block heating		
Reset maximum pointer		

Menu: Statistics		
Statistical data	Motor current I_{max} (%)	
	Motor current I_{max} (rms)	
	Last tripping current I_A (%)	
	Last tripping current I_A (rms)	
	Operating hours - device	
	Operating hours - motor	
	Number of starts motor CW	
	Number of starts motor CCW	
	Number of overload trips	
	Number of stops with electrical braking	
	Number of starts output 1	
	Number of starts output 2	
	Number of starts output 3	
	Number of starts output 4	

Menu: Safety			
		Factory settings	Customer settings
Enter user code		1000	
User level	Customer read only (> 1000)		
	Customer write (1000)		

11.2 Transport and storage conditions

Transport and storage conditions

The soft starters comply with the requirements of DIN IEC 721-3-1/HD478.3.1 S1 for transport and storage conditions. The following information applies to modules transported and stored in the original packaging.

Type of condition	Permissible range
Temperature	-25°C to +80°C
Atmospheric pressure	700 to 1060 hPa
Relative humidity	10 to 95 %

11.3 Technical data

11.3.1 Selection and ordering data

Table 11- 1 Normal starting (CLASS 10) in inline circuit - Part 1/3

Rated operational voltage U _e	Ambient temperature 40 °C					Ambient temperature 50 °C					Article No.
	Rated operational current I _e	Rated power of three-phase motors at rated operational voltage U _e				Rated operational current I _e	Rated power of three-phase motors at rated operational voltage U _e				
V	A	230 V kW	400 V kW	500 V kW	690 V kW	A	200 V HP	230 V HP	460 V HP	575 V HP	
200 ... 460	29	5.5	15	-	-	26	7.5	7.5	15	-	3RW44 22-x ¹ BCx ² 4
	36	7.5	18.5	-	-	32	10	10	20	-	3RW44 23-x ¹ BCx ² 4
	47	11	22	-	-	42	10	15	25	-	3RW44 24-x ¹ BCx ² 4
	57	15	30	-	-	51	15	15	30	-	3RW44 25-x ¹ BCx ² 4
	77	18.5	37	-	-	68	20	20	50	-	3RW44 26-x ¹ BCx ² 4
	93	22	45	-	-	82	25	25	60	-	3RW44 27-x ¹ BCx ² 4
400 ... 600	29	-	15	18.5	-	26	-	-	15	20	3RW44 22-x ¹ BCx ² 5
	36	-	18.5	22	-	32	-	-	20	25	3RW44 23-x ¹ BCx ² 5
	47	-	22	30	-	42	-	-	25	30	3RW44 24-x ¹ BCx ² 5
	57	-	30	37	-	51	-	-	30	40	3RW44 25-x ¹ BCx ² 5
	77	-	37	45	-	68	-	-	50	50	3RW44 26-x ¹ BCx ² 5
	93	-	45	55	-	82	-	-	60	75	3RW44 27-x ¹ BCx ² 5
400 ... 690	29	-	15	18.5	30	26	-	-	15	20	3RW44 22-x ¹ BCx ² 6
	36	-	18.5	22	37	32	-	-	20	25	3RW44 23-x ¹ BCx ² 6
	47	-	22	30	45	42	-	-	25	30	3RW44 24-x ¹ BCx ² 6
	57	-	30	37	55	51	-	-	30	40	3RW44 25-x ¹ BCx ² 6
	77	-	37	45	75	68	-	-	50	50	3RW44 26-x ¹ BCx ² 6
	93	-	45	55	90	82	-	-	60	75	3RW44 27-x ¹ BCx ² 6

x¹ 1 = screw-type terminals, 3 = spring-loaded terminals

Table 11- 2 Normal starting (CLASS 10) in inline circuit - Part 2/3

Rated operational voltage U _e	Ambient temperature 40 °C					Ambient temperature 50 °C					Article No.
	Rated operational current I _e	Rated power of three-phase motors at rated operational voltage U _e				Rated operational current I _e	Rated power of three-phase motors at rated operational voltage U _e				
		230 V kW	400 V kW	500 V kW	690 V kW		200 V HP	230 V HP	460 V HP	575 V HP	
V	A					A					
200 ... 460	113	30	55	-	-	100	30	30	75	-	3RW44 34-x ¹ BCx ² 4
	134	37	75	-	-	117	30	40	75	-	3RW44 35-x ¹ BCx ² 4
	162	45	90	-	-	145	40	50	100	-	3RW44 36-x ¹ BCx ² 4
	203	55	110	-	-	180	50	60	125	-	3RW44 43-x ¹ BCx ² 4
	250	75	132	-	-	215	60	75	150	-	3RW44 44-x ¹ BCx ² 4
	313	90	160	-	-	280	75	100	200	-	3RW44 45-x ¹ BCx ² 4
	356	110	200	-	-	315	100	125	250	-	3RW44 46-x ¹ BCx ² 4
	432	132	250	-	-	385	125	150	300	-	3RW44 47-x ¹ BCx ² 4
	551	160	315	-	-	494	150	200	400	-	3RW44 53-x ¹ BCx ² 4
	615	200	355	-	-	551	150	200	450	-	3RW44 54-x ¹ BCx ² 4
	693	200	400	-	-	615	200	250	500	-	3RW44 55-x ¹ BCx ² 4
	780	250	450	-	-	693	200	250	600	-	3RW44 56-x ¹ BCx ² 4
	880	250	500	-	-	780	250	300	700	-	3RW44 57-x ¹ BCx ² 4
	970	315	560	-	-	850	300	350	750	-	3RW44 58-x ¹ BCx ² 4
1076	355	630	-	-	970	350	400	850	-	3RW44 65-x ¹ BCx ² 4	
1214	400	710	-	-	1076	350	450	950	-	3RW44 66-x ¹ BCx ² 4	
400 ... 600	113	-	55	75	-	100	-	-	75	75	3RW44 34-x ¹ BCx ² 5
	134	-	75	90	-	117	-	-	75	100	3RW44 35-x ¹ BCx ² 5
	162	-	90	110	-	145	-	-	100	125	3RW44 36-x ¹ BCx ² 5
	203	-	110	132	-	180	-	-	125	150	3RW44 43-x ¹ BCx ² 5
	250	-	132	160	-	215	-	-	150	200	3RW44 44-x ¹ BCx ² 5
	313	-	160	200	-	280	-	-	200	250	3RW44 45-x ¹ BCx ² 5
	356	-	200	250	-	315	-	-	250	300	3RW44 46-x ¹ BCx ² 5
	432	-	250	315	-	385	-	-	300	400	3RW44 47-x ¹ BCx ² 5
	551	-	315	355	-	494	-	-	400	500	3RW44 53-x ¹ BCx ² 5
	615	-	355	400	-	551	-	-	450	600	3RW44 54-x ¹ BCx ² 5
	693	-	400	500	-	615	-	-	500	700	3RW44 55-x ¹ BCx ² 5
	780	-	450	560	-	693	-	-	600	750	3RW44 56-x ¹ BCx ² 5
	880	-	500	630	-	780	-	-	700	850	3RW44 57-x ¹ BCx ² 5
	970	-	560	710	-	850	-	-	750	900	3RW44 58-x ¹ BCx ² 5
1076	-	630	800	-	970	-	-	850	1100	3RW44 65-x ¹ BCx ² 5	
1214		710	900		1076	-	-	950	1200	3RW44 66-x ¹ BCx ² 5	

x¹ 2 = screw-type terminals, 6 = spring-loaded terminalsx² 3 = 115 V AC, 4 = 230 V AC

11.3 Technical data

Table 11- 3 Normal starting (CLASS 10) in inline circuit - Part 3/3

Rated operational voltage U _e	Ambient temperature 40 °C					Ambient temperature 50 °C					Article No.
	Rated operational current I _e	Rated power of three-phase motors at rated operational voltage U _e				Rated operational current I _e	Rated power of three-phase motors at rated operational voltage U _e				
V	A	230 V kW	400 V kW	500 V kW	690 V kW	A	200 V HP	230 V HP	460 V HP	575 V HP	
400 ... 690	113	-	55	75	110	100	-	-	75	75	3RW44 34-x ¹ BCx ² 6
	134	-	75	90	132	117	-	-	75	100	3RW44 35-x ¹ BCx ² 6
	162	-	90	110	160	145	-	-	100	125	3RW44 36-x ¹ BCx ² 6
	203	-	110	132	200	180	-	-	125	150	3RW44 43-x ¹ BCx ² 6
	250	-	132	160	250	215	-	-	150	200	3RW44 44-x ¹ BCx ² 6
	313	-	160	200	315	280	-	-	200	250	3RW44 45-x ¹ BCx ² 6
	356	-	200	250	355	315	-	-	250	300	3RW44 46-x ¹ BCx ² 6
	432	-	250	315	400	385	-	-	300	400	3RW44 47-x ¹ BCx ² 6
	551	-	315	355	560	494	-	-	400	500	3RW44 53-x ¹ BCx ² 6
	615	-	355	400	630	551	-	-	450	600	3RW44 54-x ¹ BCx ² 6
	693	-	400	500	710	615	-	-	500	700	3RW44 55-x ¹ BCx ² 6
	780	-	450	560	800	693	-	-	600	750	3RW44 56-x ¹ BCx ² 6
	880	-	500	630	900	780	-	-	700	850	3RW44 57-x ¹ BCx ² 6
	970	-	560	710	1000	850	-	-	750	900	3RW44 58-x ¹ BCx ² 6
1076	-	630	800	1100	970	-	-	850	1100	3RW44 65-x ¹ BCx ² 6	
1214	-	710	900	1200	1076	-	-	950	1200	3RW44 66-x ¹ BCx ² 6	

x¹ 2 = screw-type terminals, 6 = spring-loaded terminals

x² 3 = 115 V AC, 4 = 230 V AC

Table 11-4 Normal starting (CLASS 10) in inside-delta circuit - Part 1/2

Rated operational voltage U _e	Ambient temperature 40 °C					Ambient temperature 50 °C					Article No.
	Rated operational current I _e	Rated power of three-phase motors at rated operational voltage U _e				Rated operational current I _e	Rated power of three-phase motors at rated operational voltage U _e				
V	A	230 V kW	400 V kW	500 V kW	690 V kW	A	200 V HP	230 V HP	460 V HP	575 V HP	
200 ... 460	50	15	22	-	-	45	10	15	30	-	3RW44 22-x ¹ BCx ² 4
	62	18.5	30	-	-	55	15	20	40	-	3RW44 23-x ¹ BCx ² 4
	81	22	45	-	-	73	20	25	50	-	3RW44 24-x ¹ BCx ² 4
	99	30	55	-	-	88	25	30	60	-	3RW44 25-x ¹ BCx ² 4
	133	37	75	-	-	118	30	40	75	-	3RW44 26-x ¹ BCx ² 4
	161	45	90	-	-	142	40	50	100	-	3RW44 27-x ¹ BCx ² 4
400 ... 600	50	-	22	30	-	45	-	-	30	40	3RW44 22-x ¹ BCx ² 5
	62	-	30	37	-	55	-	-	40	50	3RW44 23-x ¹ BCx ² 5
	81	-	45	45	-	73	-	-	50	60	3RW44 24-x ¹ BCx ² 5
	99	-	55	55	-	88	-	-	60	75	3RW44 25-x ¹ BCx ² 5
	133	-	75	90	-	118	-	-	75	100	3RW44 26-x ¹ BCx ² 5
	161	-	90	110	-	142	-	-	100	125	3RW44 27-x ¹ BCx ² 5

x¹ 1 = screw-type terminals, 3 = spring-loaded terminals

11.3 Technical data

Table 11- 5 Normal starting (CLASS 10) in inside-delta circuit - Part 2/2

Rated operational voltage U _e	Ambient temperature 40 °C					Ambient temperature 50 °C					Article No.
	Rated operational current I _e	Rated power of three-phase motors at rated operational voltage U _e				Rated operational current I _e	Rated power of three-phase motors at rated operational voltage U _e				
		230 V kW	400 V kW	500 V kW	690 V kW		200 V HP	230 V HP	460 V HP	575 V HP	
V	A					A					
200 ... 460	196	55	110	-	-	173	50	60	125	-	3RW44 34-x ¹ BCx ² 4
	232	75	132	-	-	203	60	75	150	-	3RW44 35-x ¹ BCx ² 4
	281	90	160	-	-	251	75	100	200	-	3RW44 36-x ¹ BCx ² 4
	352	110	200	-	-	312	100	125	250	-	3RW44 43-x ¹ BCx ² 4
	433	132	250	-	-	372	125	150	300	-	3RW44 44-x ¹ BCx ² 4
	542	160	315	-	-	485	150	200	400	-	3RW44 45-x ¹ BCx ² 4
	617	200	355	-	-	546	150	200	450	-	3RW44 46-x ¹ BCx ² 4
	748	250	400	-	-	667	200	250	600	-	3RW44 47-x ¹ BCx ² 4
	954	315	560	-	-	856	300	350	750	-	3RW44 53-x ¹ BCx ² 4
	1065	355	630	-	-	954	350	400	850	-	3RW44 54-x ¹ BCx ² 4
	1200	400	710	-	-	1065	350	450	950	-	3RW44 55-x ¹ BCx ² 4
	1351	450	800	-	-	1200	450	500	1050	-	3RW44 56-x ¹ BCx ² 4
	1524	500	900	-	-	1351	450	600	1200	-	3RW44 57-x ¹ BCx ² 4
	1680	560	1000	-	-	1472	550	650	1300	-	3RW44 58-x ¹ BCx ² 4
1864	630	1100	-	-	1680	650	750	1500	-	3RW44 65-x ¹ BCx ² 4	
2103	710	1200	-	-	1864	700	850	1700	-	3RW44 66-x ¹ BCx ² 4	
400 ... 600	196	-	110	132	-	173	-	-	125	150	3RW44 34-x ¹ BCx ² 5
	232	-	132	160	-	203	-	-	150	200	3RW44 35-x ¹ BCx ² 5
	281	-	160	200	-	251	-	-	200	250	3RW44 36-x ¹ BCx ² 5
	352	-	200	250	-	312	-	-	250	300	3RW44 43-x ¹ BCx ² 5
	433	-	250	315	-	372	-	-	300	350	3RW44 44-x ¹ BCx ² 5
	542	-	315	355	-	485	-	-	400	500	3RW44 45-x ¹ BCx ² 5
	617	-	355	450	-	546	-	-	450	600	3RW44 46-x ¹ BCx ² 5
	748	-	400	500	-	667	-	-	600	750	3RW44 47-x ¹ BCx ² 5
	954	-	560	630	-	856	-	-	750	950	3RW44 53-x ¹ BCx ² 5
	1065	-	630	710	-	954	-	-	850	1050	3RW44 54-x ¹ BCx ² 5
	1200	-	710	800	-	1065	-	-	950	1200	3RW44 55-x ¹ BCx ² 5
	1351	-	800	900	-	1200	-	-	1050	1350	3RW44 56-x ¹ BCx ² 5
	1524	-	900	1000	-	1351	-	-	1200	1500	3RW44 57-x ¹ BCx ² 5
	1680	-	1000	1200	-	1472	-	-	1300	1650	3RW44 58-x ¹ BCx ² 5
1864	-	1100	1350	-	1680	-	-	1500	1900	3RW44 65-x ¹ BCx ² 5	
2103	-	1200	1500	-	1864	-	-	1700	2100	3RW44 66-x ¹ BCx ² 5	

x¹ 2 = screw-type terminals, 6 = spring-loaded terminals

x² 3 = 115 V AC, 4 = 230 V AC

General supplementary conditions	
Maximum starting time:	10 s
Current limiting	300 %
Starts/hour	5
ON time	30%
Assembly type	Stand-alone installation
Installation altitude	Max. 1000 m/3280 ft
Ambient temperature	<ul style="list-style-type: none"> • kW: 40 °C/104 °F • hp: 50 °C/122 °F

The listed motor ratings are only approximate values. The soft starter should always be designed on the basis of the motor current (rated operational current). A larger model may need to be selected for different conditions.

Motor output ratings are based on DIN 42973 (kW) and NEC 96/UL508 (hp).

Design with Simulation Tool for Soft Starters (STS)

For dimensioning soft starters under other supplementary conditions, also for heavy starting up to CLASS 30, we recommend our Simulation Tool for Soft Starters (STS ([https://support.industry.siemens.com/cs/document/101494917/simulation-tool-for-soft-starters-\(sts\)?dti=0&lc=en-VW](https://support.industry.siemens.com/cs/document/101494917/simulation-tool-for-soft-starters-(sts)?dti=0&lc=en-VW))).

11.3.2 Technical data of the power unit

Type		3RW44 ...-BC.4	3RW44 ...-BC.5	3RW44 ...-BC.6
Power electronics				
Rated operational voltage for standard circuit	V	200 ... 460 AC	400 ... 600 AC	400 ... 690 AC
Tolerance	%	-15 / +10	-15 / +10	-15 / +10
Rated operational voltage for inside delta circuit	V	200 ... 460 AC	400 ... 600 AC	400 ... 600 AC
Tolerance	%	-15 / +10	-15 / +10	-15 / +10
Maximum blocking voltage thyristor	V	1400	1800	1800
Rated frequency	Hz	50 ... 60		
Tolerance	%	±10		
Continuous operation at 40 °C (% of I _S)	%	115		
Minimum load (% of set motor current I _M)	%	8		
Maximum cable length between soft starter and motor	m	500 ^{a)}		
Permissible installation height	m	5000 (for derating above 1000, see characteristic curves); higher on request		
Permissible mounting position and installation type (stand-alone installation)				
Permissible ambient temperature				
Operation	°C	0 ... +60; (derating above +40)		
Storage	°C	-25 ... +80		
Degree of protection		IP00		

^{a)} During configuration, the voltage drop on the motor line must be taken into consideration up to the motor connection. It may be necessary to select a larger dimensioned soft starter with regard to the rated operational voltage and/or the rated operating current.

	3RW44...-BC.4	3RW44...-BC.5	3RW44...-BC.6
Rated insulation voltage U _i	460 V	600 V	690 V
Rate impulse voltage U _{imp}	6 kV		

Type		3RW44 22	3RW44 23	3RW44 24	3RW44 25	3RW44 26	3RW44 27
Power electronics							
Rated operating current I_e		29	36	47	57	77	93
Carrying capacity, rated operating current I_e							
• According to IEC and UL / CSA ¹⁾ , for single mounting, AC-53a							
- At 40 / 50 / 60 °C	A	29 / 26 / 23	36 / 32 / 29	47 / 42 / 37	57 / 51 / 45	77 / 68 / 59	93 / 82 / 72
Minimum selectable nominal motor current I_M for motor overload protection	A	5	7	9	11	15	18
Power loss							
• Uninterrupted rated operating current after run up (40 / 50 / 60 °C) approx.							
	W	8 / 7.5 / 7	10 / 9 / 8.5	32 / 31 / 29	36 / 34 / 31	45 / 41 / 37	55 / 51 / 47
• When starting with current limiting set at 350 % I_M (40 / 50 / 60 °C)							
	W	400 / 345 / 290	470 / 410 / 355	600 / 515 / 440	725 / 630 / 525	940 / 790 / 660	1160 / 980 / 830
Permitted rated motor current and starts per hour							
• For normal starting (CLASS 5)							
- Rated motor current $I_M^{(2)}$, run-up time 5 s	A	29 / 26 / 23	36 / 32.5 / 29	47 / 42 / 37	57 / 51 / 45	77 / 68 / 59	93 / 82 / 72
- Starts per hour ³⁾	1/h	41	34	41	41	41	41
- Rated motor current $I_M^{(2)}$, run-up time 10 s	A	29 / 26 / 23	36 / 32.5 / 29	47 / 42 / 37	57 / 51 / 45	77 / 68 / 59	93 / 82 / 72
- Starts per hour ³⁾	1/h	20	15	20	20	20	20
• For normal starting (CLASS 10)							
- Rated motor current $I_M^{(2)}$, run-up time 10 s	A	29 / 26 / 23	36 / 32.5 / 29	47 / 42 / 37	57 / 51 / 45	77 / 68 / 59	93 / 82 / 72
- Starts per hour ³⁾	1/h	20	15	20	20	20	20
- Rated motor current $I_M^{(2)}$, run-up time 20 s	A	29 / 26 / 23	36 / 32.5 / 29	47 / 42 / 37	57 / 51 / 45	77 / 68 / 59	93 / 82 / 72
- Starts per hour ³⁾	1/h	10	6	10	10	8	8
• For normal starting (CLASS 15)							
- Rated motor current $I_M^{(2)}$, run-up time 15 s	A	29 / 26 / 23	36 / 32.5 / 29	47 / 42 / 37	57 / 51 / 45	77 / 68 / 59	93 / 82 / 72
- Starts per hour ³⁾	1/h	13	9	13	13	13	13
- Rated motor current $I_M^{(2)}$, run-up time 30 s	A	29 / 26 / 23	36 / 32.5 / 29	47 / 42 / 37	57 / 51 / 45	77 / 68 / 59	93 / 82 / 72
- Starts per hour ³⁾	1/h	6	4	6	6	6	6
• For heavy starting (CLASS 20)							
- Rated motor current $I_M^{(2)}$, run-up time 20 s	A	29 / 26 / 23	36 / 32.5 / 29	47 / 42 / 37	57 / 51 / 45	77 / 68 / 59	88 / 80 / 72
- Starts per hour ³⁾	1/h	10	6	10	10	10	10
- Rated motor current $I_M^{(2)}$, run-up time 40 s	A	29 / 26 / 23	36 / 32.5 / 29	47 / 42 / 37	57 / 51 / 45	77 / 68 / 59	88 / 80 / 72
- Starts per hour ³⁾	1/h	4	2	4	5	1.8	0.8
• For very heavy starting (CLASS 30)							
- Rated motor current $I_M^{(2)}$, run-up time 30 s	A	29 / 26 / 23	36 / 32.5 / 29	47 / 42 / 37	57 / 51 / 45	65 / 60 / 54	77 / 70 / 63
- Starts per hour ³⁾	1/h	6	4	6	6	6	6
- Rated motor current $I_M^{(2)}$, run-up time 60 s	A	29 / 26 / 23	36 / 32.5 / 29	47 / 42 / 37	57 / 51 / 45	65 / 60 / 54	77 / 70 / 63
- Starts per hour ³⁾	1/h	1.8	0.8	3.3	1.5	2	1

1) Measurement at 60 °C not required according to UL/CSA.

2) Current limiting on soft starter set at 350 % I_M ; on-time OT = 70 %.
Maximum selectable rated motor current I_M , depending on the CLASS settings.

3) During intermittent duty S4 with on-time OT = 70 %, $T_U = 40 / 50 / 60$ °C, vertical stand-alone installation. The listed switching frequencies do not apply to automatic operation.

11.3 Technical data

Type		3RW44 34	3RW44 35	3RW44 36
Power electronics				
Rated operating current I_e		113	134	162
Carrying capacity, rated operating current I_e				
• According to IEC and UL / CSA ¹⁾ , for single mounting, AC-53a				
- At 40 °C	A	113	134	162
- At 50 °C	A	100	117	145
- At 60 °C	A	88	100	125
Minimum selectable nominal motor current I_M For motor overload protection	A	22	26	32
Power loss				
• Uninterrupted rated operating current after run up (40 / 50 / 60 °C) approx.	W	64 / 58 / 53	76 / 67 / 58	95 / 83 / 71
• When starting with current limiting set at 350 % I_M (40 / 50 / 60 °C)	W	1350 / 1140 / 970	1700 / 1400 / 1140	2460 / 1980 / 1620
Permitted rated motor current and starts per hour				
• For normal starting (CLASS 5)				
- Rated motor current $I_M^{(2)}$, run-up time 5 s	A	113 / 100 / 88	134 / 117 / 100	162 / 145 / 125
- Starts per hour ³⁾	1/h	41	39	41
- Rated motor current $I_M^{(2)}$, run-up time 10 s	A	113 / 100 / 88	134 / 117 / 100	162 / 145 / 125
- Starts per hour ³⁾	1/h	20	15	20
• For normal starting (CLASS 10)				
- Rated motor current $I_M^{(2)}$, run-up time 10 s	A	113 / 100 / 88	134 / 117 / 100	162 / 145 / 125
- Starts per hour ³⁾	1/h	20	15	20
- Rated motor current $I_M^{(2)}$, run-up time 20 s	A	113 / 100 / 88	134 / 117 / 100	162 / 145 / 125
- Starts per hour ³⁾	1/h	9	6	7
• For normal starting (CLASS 15)				
- Rated motor current $I_M^{(2)}$, run-up time 15 s	A	113 / 100 / 88	134 / 117 / 100	162 / 145 / 125
- Starts per hour ³⁾	1/h	13	9	12
- Rated motor current $I_M^{(2)}$, run-up time 30 s	A	113 / 100 / 88	134 / 117 / 100	162 / 145 / 125
- Starts per hour ³⁾	1/h	6	6	1
• For heavy starting (CLASS 20)				
- Rated motor current $I_M^{(2)}$, run-up time 20 s	A	106 / 97 / 88	125 / 113 / 100	147 / 134 / 122
- Starts per hour ³⁾	1/h	9	9	10
- Rated motor current $I_M^{(2)}$, run-up time 40 s	A	106 / 97 / 88	125 / 113 / 100	147 / 134 / 122
- Starts per hour ³⁾	1/h	1.5	2	1
• For very heavy starting (CLASS 30)				
- Rated motor current $I_M^{(2)}$, run-up time 30 s	A	91 / 84 / 76	110 / 100 / 90	120 / 110 / 100
- Starts per hour ³⁾	1/h	6	6	6
- Rated motor current $I_M^{(2)}$, run-up time 60 s	A	91 / 84 / 76	110 / 100 / 90	120 / 110 / 100
- Starts per hour ³⁾	1/h	2	2	2

1) Measurement at 60 °C not required according to UL/CSA.

2) Current limiting on soft starter set at 350 % I_M ; on-time OT = 70 %.
Maximum selectable rated motor current I_M , depending on the CLASS settings.

3) During intermittent duty S4 with on-time OT = 70 %, $T_u = 40/50/60$ °C, vertical stand-alone installation. The listed switching frequencies do not apply to automatic operation.

Type		3RW44 43	3RW44 44	3RW44 45	3RW44 46	3RW44 47
Power electronics						
Rated operating current I_e		203	250	313	356	432
Carrying capacity, rated operating current I_e						
• According to IEC and UL / CSA ¹⁾ , for single mounting, AC-53a						
- At 40 °C	A	203	250	313	356	432
- At 50 °C	A	180	215	280	315	385
- At 60 °C	A	156	185	250	280	335
Minimum selectable nominal motor current I_M For motor overload protection	A	40	50	62	71	86
Power loss						
• Uninterrupted rated operating current after run up (40 / 50 / 60 °C) approx.	W	89 / 81 / 73	110 / 94 / 83	145 / 126 / 110	174 / 147 / 126	232 / 194 / 159
• When starting with current limiting set at 350 % I_M (40 / 50 / 60 °C)	W	3350 / 2600 / 2150	4000 / 2900 / 2350	4470 / 4000 / 3400	5350 / 4050 / 3500	5860 / 5020 / 4200
Permitted rated motor current and starts per hour						
• For normal starting (CLASS 5)						
- Rated motor current $I_M^{(2)}$, run-up time 5 s	A	203 / 180 / 156	250 / 215 / 185	313 / 280 / 250	356 / 315 / 280	432 / 385 / 335
- Starts per hour ³⁾	1/h	41	41	41	41	39
- Rated motor current $I_M^{(2)}$, run-up time 10 s	A	203 / 180 / 156	250 / 215 / 185	313 / 280 / 250	356 / 315 / 280	432 / 385 / 335
- Starts per hour ³⁾	1/h	20	20	19	17	16
• For normal starting (CLASS 10)						
- Rated motor current $I_M^{(2)}$, run-up time 10 s	A	203 / 180 / 156	250 / 215 / 185	313 / 280 / 250	356 / 315 / 280	432 / 385 / 335
- Starts per hour ³⁾	1/h	20	20	19	17	16
- Rated motor current $I_M^{(2)}$, run-up time 20 s	A	203 / 180 / 156	250 / 215 / 185	313 / 280 / 250	356 / 315 / 280	432 / 385 / 335
- Starts per hour ³⁾	1/h	9	10	6	4	5
• For normal starting (CLASS 15)						
- Rated motor current $I_M^{(2)}$, run-up time 15 s	A	203 / 180 / 156	240 / 215 / 185	313 / 280 / 250	325 / 295 / 265	402 / 385 / 335
- Starts per hour ³⁾	1/h	13	13	10	13	11
- Rated motor current $I_M^{(2)}$, run-up time 30 s	A	203 / 180 / 156	240 / 215 / 185	313 / 280 / 250	325 / 295 / 265	402 / 385 / 335
- Starts per hour ³⁾	1/h	3	6	1	2	1
• For heavy starting (CLASS 20)						
- Rated motor current $I_M^{(2)}$, run-up time 20 s	A	195 / 175 / 155	215 / 195 / 180	275 / 243 / 221	285 / 263 / 240	356 / 326 / 295
- Starts per hour ³⁾	1/h	10	10	10	10	10
- Rated motor current $I_M^{(2)}$, run-up time 40 s	A	195 / 175 / 155	215 / 195 / 180	275 / 243 / 221	285 / 263 / 240	356 / 326 / 295
- Starts per hour ³⁾	1/h	1	5	1	3	1
• For very heavy starting (CLASS 30)						
- Rated motor current $I_M^{(2)}$, run-up time 30 s	A	162 / 148 / 134	180 / 165 / 150	220 / 201 / 182	240 / 223 / 202	285 / 260 / 235
- Starts per hour ³⁾	1/h	6	6	6	6	6
- Rated motor current $I_M^{(2)}$, run-up time 60 s	A	162 / 148 / 134	180 / 165 / 150	220 / 201 / 182	240 / 223 / 202	285 / 260 / 235
- Starts per hour ³⁾	1/h	3	3	3	2	1

1) Measurement at 60 °C not required according to UL/CSA.

2) Current limiting on soft starter set at 350 % I_M ; on-time OT = 70 %.
Maximum selectable rated motor current I_M , depending on the CLASS settings.

3) During intermittent duty S4 with on-time OT = 70 %, $T_U = 40/50/60$ °C, vertical stand-alone installation. The listed switching frequencies do not apply to automatic operation.

11.3 Technical data

Type		3RW44 53	3RW44 54	3RW44 55	3RW44 56	3RW44 57	3RW44 58	3RW44 65	3RW44 66
Power electronics									
Carrying capacity, rated operating current I_e									
• According to IEC and UL / CSA ¹⁾ , for single mounting, AC-53a, at 40 °C	A	551	615	693	780	880	970	1076	1214
• According to IEC and UL / CSA ¹⁾ , for single mounting, AC-53a, at 50 °C	A	494	551	615	693	780	850	970	1076
• According to IEC and UL / CSA ¹⁾ , for single mounting, AC-53a, at 60 °C	A	438	489	551	615	693	760	880	970
Minimum selectable nominal motor current I_M for motor overload protection	A	110	123	138	156	176	194	215	242
Power loss									
• Uninterrupted rated operating current after run up (40 °C) approx.	W	159	186	220	214	250	270	510	630
• Uninterrupted rated operating current after run up (50 °C) approx.	W	135	156	181	176	204	215	420	510
• Uninterrupted rated operating current after run up (60 °C) approx.	W	113	130	152	146	168	179	360	420
• When starting with current limiting set at 350 % I_M (40 °C)	W	7020	8100	9500	11100	13100	15000	15000	17500
• When starting with current limiting set at 350 % I_M (50 °C)	W	6111	7020	8100	9500	11000	12500	13000	15000
• When starting with current limiting set at 350 % I_M (60 °C)	W	5263	5996	7020	8100	8100	10700	11500	13000
Permitted rated motor current and starts per hour									
• For normal starting (CLASS 5)									
- Rated motor current $I_M^{(2)}$, run-up time 5 s, at 40 °C	A	551	615	693	780	880	970	1076	1214
- Rated motor current $I_M^{(2)}$, run-up time 5 s, at 50 °C	A	494	551	615	693	780	850	970	1076
- Rated motor current $I_M^{(2)}$, run-up time 5 s, at 60 °C	A	438	489	551	615	693	760	880	970
- Starts per hour ³⁾	1/h	41	41	37	33	22	17	30	20
- Rated motor current $I_M^{(2)}$, run-up time 10 s, at 40 °C	A	551	615	693	780	880	970	1076	1214
- Rated motor current $I_M^{(2)}$, run-up time 10 s, at 50 °C	A	494	551	615	693	780	850	970	1076
- Rated motor current $I_M^{(2)}$, run-up time 10 s, at 60 °C	A	438	489	551	615	693	760	880	970
- Starts per hour ³⁾	1/h	20	20	16	13	8	5	10	6
• For normal starting (CLASS 10)									
- Rated motor current $I_M^{(2)}$, run-up time 10 s, at 40 °C	A	551	615	693	780	880	970	1076	1214
- Rated motor current $I_M^{(2)}$, run-up time 10 s, at 50 °C	A	494	551	615	693	780	850	970	1076
- Rated motor current $I_M^{(2)}$, run-up time 10 s, at 60 °C	A	438	489	551	615	693	760	880	970
- Starts per hour ³⁾	1/h	20	20	16	13	8	5	11	6
- Rated motor current $I_M^{(2)}$, run-up time 20 s, at 40 °C	A	551	615	693	780	880	970	1076	1214
- Rated motor current $I_M^{(2)}$, run-up time 20 s, at 50 °C	A	494	551	615	693	780	850	970	1076
- Rated motor current $I_M^{(2)}$, run-up time 20 s, at 60 °C	A	438	489	551	615	693	760	880	970
- Starts per hour ³⁾	1/h	10	9	6	4	0.3	0.3	3	0.5
• For normal starting (CLASS 15)									
- Rated motor current $I_M^{(2)}$, run-up time 15 s, at 40 °C	A	551	615	666	723	780	821	1020	1090
- Rated motor current $I_M^{(2)}$, run-up time 15 s, at 50 °C	A	494	551	615	693	710	755	950	1000
- Rated motor current $I_M^{(2)}$, run-up time 15 s, at 60 °C	A	438	489	551	615	650	693	850	920
- Starts per hour ³⁾	1/h	13	13	11	9	8	8	7	5
- Rated motor current $I_M^{(2)}$, run-up time 30 s, at 40 °C	A	551	615	666	723	780	821	1020	1090
- Rated motor current $I_M^{(2)}$, run-up time 30 s, at 50 °C	A	494	551	615	693	710	755	950	1000
- Rated motor current $I_M^{(2)}$, run-up time 30 s, at 60 °C	A	438	489	551	615	650	693	850	920
- Starts per hour ³⁾	1/h	6	4	3	1	0.4	0.5	1	1
• For heavy starting (CLASS 20)									
- Rated motor current $I_M^{(2)}$, run-up time 20 s, at 40 °C	A	551	591	633	670	710	740	970	1030
- Rated motor current $I_M^{(2)}$, run-up time 20 s, at 50 °C	A	494	551	615	634	650	685	880	940
- Rated motor current $I_M^{(2)}$, run-up time 20 s, at 60 °C	A	438	489	551	576	590	630	810	860
- Starts per hour ³⁾	1/h	10	10	7	8	8	9	7	5
- Rated motor current $I_M^{(2)}$, run-up time 40 s, at 40 °C	A	551	591	633	670	710	740	970	1030
- Rated motor current $I_M^{(2)}$, run-up time 40 s, at 50 °C	A	494	551	615	634	650	685	880	940
- Rated motor current $I_M^{(2)}$, run-up time 40 s, at 60 °C	A	438	489	551	576	590	630	810	860
- Starts per hour ³⁾	1/h	4	2	1	1	0.4	1	1	1
• For very heavy starting (CLASS 30)									
- Rated motor current $I_M^{(2)}$, run-up time 30 s, at 40 °C	A	500	525	551	575	600	630	880	920
- Rated motor current $I_M^{(2)}$, run-up time 30 s, at 50 °C	A	480	489	520	540	550	580	810	850
- Rated motor current $I_M^{(2)}$, run-up time 30 s, at 60 °C	A	438	455	480	490	500	530	740	780
- Starts per hour ³⁾	1/h	6	6	6	6	6	6	6	6
- Rated motor current $I_M^{(2)}$, run-up time 60 s, at 40 °C	A	500	525	551	575	600	630	880	920
- Rated motor current $I_M^{(2)}$, run-up time 60 s, at 50 °C	A	480	489	520	540	550	580	810	850
- Rated motor current $I_M^{(2)}$, run-up time 60 s, at 60 °C	A	438	455	480	490	500	530	740	780
- Starts per hour ³⁾	1/h	2	1	1	1	1.5	1	1	1

1) Measurement at 60 °C not required according to UL / CSA.
 2) Current limiting on soft starter set at 350 % I_M , on-time OT = 70 %.
 Maximum selectable rated motor current I_M depending on the CLASS settings.
 3) During intermittent duty S4 with on-time OT = 70 %, $T_u = 40 / 50 / 60$ °C, vertical stand-alone installation. The listed switching frequencies do not apply to automatic operation.

11.3.3 Technical data of the control section

Type	Terminal		3RW44 ...BC3.	3RW44 ...BC4.
Control unit				
Rated values				
Rated control supply voltage	A1 / A2 / PE	V	115 AC	230 AC
• Tolerance		%	-15 / +10	-15 / +10
Rated control supply current STANDBY		mA	30	20
Rated control supply current ON				
• 3RW44 2.		mA	300	170
• 3RW44 3.		mA	500	250
• 3RW44 4.		mA	750	400
• 3RW44 5.		mA	450	200
• 3RW44 6.		mA	650	300
Maximum current (pickup bypass)				
• 3RW44 2.		mA	1000	500
• 3RW44 3.		mA	2500	1250
• 3RW44 4.		mA	6000	3000
• 3RW44 5.		mA	4500	2500
• 3RW44 6.		mA	4500	2500
Rated frequency		Hz	50 ... 60	50 ... 60
• Tolerance		%	±10	±10
Inrush current			< 15 A / 300 µs	
Control unit				
Type	Terminal		3RW44 ..	Factory setting
Control inputs				
Input 1	IN1		Approx. 10 per input according to DIN 19240 Internal voltage: 24 V DC from internal supply via terminal L+ to IN1 ... IN4. Maximum load at L+ approx. 55 mA External voltage: DC externalvoltage (according to DIN 19240) via terminals L- and IN1 ... IN4 (min. 12 V DC, max. 30 V DC)	Start motor right parameter set 1 No Action No Action Trip Reset
Input 2	IN2			
Input 3	IN3			
Input 4	IN4			
Supply	L+ / L-		Approx. 10 per input according to DIN 19240 Internal voltage: 24 V DC from internal supply via terminal L+ to IN1 ... IN4. Maximum load at L+ approx. 55 mA External voltage: DC externalvoltage (according to DIN 19240) via terminals L- and IN1 ... IN4 (min. 12 V DC, max. 30 V DC)	
• Rated operating current		mA		
• Rated operational voltage	L+			
	L-			
Thermistor motor protection input				
Input	T1/T2		PTC type A or Thermo click	deactivated
Relay outputs (floating auxiliary contacts)				
Output 1	13/14		Protection using varistor via relaycontact 4 A utilization category gL/gG; 6 A quick (fuse not included in scope of delivery)	On-time motor No Action No Action Group error
Output 2	23/24			
Output 3	33/34			
Output 4	95/96/98			
Switching capacity of the relay outputs				
230 V / AC-15		A	3 at 240 V	
24 V / DC-13		A	1 at 24 V	
Overvoltage protection			Protection using varistor via relaycontact 4 A utilization category gL/gG; 6 A quick (fuse not included in scope of delivery)	
Short-circuit protection				
Protective functions				
Motor protection functions				
Tripping when			motor is thermally overloaded	10
Tripping class according to IEC 60947-4-1		CLASS	5 / 10 / 15 / 20 / 30	
Phase loss sensitivity		%	>40	
Overload warning			Yes	Manual Manual 1
Reset and recovery			Manual / automatic	
Reset option after trip			Manual / automatic	
Pre-charge time		Min.	1 ... 30	
Device protection functions				
Tripping when			thyristors thermally overloaded	Manual
Reset option after trip			Manual / automatic	
Pre-charge time		Min.	0.5	
Bypass protection functions				
Tripping when			bypass contacts thermally overloaded	Manual 1
Reset option after trip			Manual	
Pre-charge time		Min.	1	

11.3 Technical data

Type		3RW44 ..	Factory setting
Control times and parameters			
Control times			
Switch-on delay (when control voltage applied)	ms	< 50	
Switch-on delay (automatic operation)	ms	< 4000	
Pre-charge time (ON command with active stopping mode)	ms	< 100	
Network failure bridging time			
Control supply voltage	ms	100	
Network failure reaction time			
Load circuit	ms	100	
Reclosing lockout after overload trip			
Motor protection tripping	Min.	1 ... 30	1
Device protection tripping	s	30	
Setting options for starting			
Voltage ramp start voltage	%	20 ... 100	30
Start torque control	%	10 ... 100	10
Limiting torque control	%	20 ... 200	150
Starting time	s	0 ... 360	20
Maximum starting time	s	1 ... 1000	deactivated
Current limiting value	%	125 ... 550 ¹⁾	450
Breakaway voltage	%	40 ... 100	80
Breakaway time	s	0 ... 2	deactivated
Motor thermal capacity	%	1 ... 100	20
Slow speed mode counter-clockwise / clockwise			
Speed factor in relation to nominal operating speed ($n = n_{\text{nominal}}/\text{factor}$)		3 ... 21	7
Slow speed torque ²⁾	%	20 ... 100	50
Setting options for stopping			
Stopping torque control	%	10 ... 100	10
Stopping time	s	0 ... 360	10
Dynamic braking torque	%	20 ... 100	50
DC braking torque	%	20 ... 100	50
Operating messages			
		Checking voltage	
		Checking line phases	
		Ready to start	
		Start mode active	
		Motor running	
		Stopping mode active	
		Emergency start active	
Warnings / error messages			
		No line voltage	
		Phase angle control failure	
		Phase loss	
		• L1 / L2 / L3	
		Missing load phase	
		• T1 / T2 / T3	
		Failure	
		• Switching element 1 (thyristor) / switching element 2 (thyristor) / switching	
		Flash memory error	
		Supply voltage	
		• below 75 %	
		• below 85 %	
		• above 110 %	
		Current unbalance exceeded	
		Thermal motor model overload	
		Prewarning limit exceeded	
		• Motor heat build-up	
		• Remaining time for tripping	
		Bypass element fault	
		Line voltage too high	
		Device not identified	
		Versions not matching	
		Current range exceeded	
		Bypass element protective tripping	
		Overcurrent	
		Motor stalling – tripping	
		Current limit exceeded	
		Power unit	
		• Overheated	
		• Overtemperature	







3RW44 22 - 3RW44 47: 550 %
 3RW44 53 - 3RW44 57: 500 %
¹⁾ max. current limiting value: 3RW44 58 - 3RW44 66: 450 %
²⁾ Reference quantity depends on motor used, but in any case lower than the rated motor torque

Type	3RW44 ..	Factory setting
Control times and parameters		
Warnings / error messages (continued)	<ul style="list-style-type: none"> Temperature sensor <ul style="list-style-type: none"> • Overload • Wire breakage • Short-circuit Ground fault <ul style="list-style-type: none"> • Detected • Tripping Connection break in manual operating mode Max. number of starts exceeded I_e limit value over / undershot Cool-down time <ul style="list-style-type: none"> • Motor active • Contact block active Heatsink thermistor <ul style="list-style-type: none"> • Wire breakage • Short-circuit Quick stop active Contact block defective Impermissible I_e / CLASS settings No external start parameters received PIO error 	
Control inputs Input 1 Input 2 Input 3 Input 4 Parameterization options for control inputs 1 ... 4	<ul style="list-style-type: none"> No Action Manual operation local operating mode Emergency start Slow speed Quick stop Trip Reset Motor right parameter set 1 Motor left parameter set 1 ¹⁾ Motor right parameter set 2 Motor left parameter set 2 ¹⁾ Motor right parameter set 3 Motor left parameter set 3 ¹⁾ 	<ul style="list-style-type: none"> Motor right parameter set 1 No Action No Action Trip Reset
Relay outputs Output 1 Output 2 Output 3 Output 4 Parameterization options for relay inputs 1 ... 3	<ul style="list-style-type: none"> No Action PIO Output 1 PIO Output 2 Input 1 Input 2 Input 3 Input 4 Run up Bypass operation Coasting down On-time motor Command motor-on Fans DC braking contactor Group warning Group error Bus error Device errors Power on Ready to start 	<ul style="list-style-type: none"> On-time motor No Action No Action Group error
Motor temperature sensor	<ul style="list-style-type: none"> deactivated Thermo click PTC type A 	deactivated

Thermistor motor protection (PTC binary)

Summation cold resistance	≤ 1.5 kOhm	
Response value	3.4 kOhm to 3.8 kOhm	
Return value	1.5 kOhm - 1.65 kOhm	
Cable lengths (single), conductor cross sections:	Cross section:	Length:
	2.5 mm ²	250 m
	1.5 mm ²	150 m
	0.5 mm ²	50 m

11.3.4 Conductor cross-sections

Type		3RW44 2.	3RW44 3.	3RW44 4.	3RW44 5. 3RW44 6.
Conductor cross-sections					
Screw-type terminals	Main conductor:				
With box terminal			3RT19 55-4G (55 kW)	3RT19 66-4G	—
Front terminal connected	<ul style="list-style-type: none"> Finely stranded with cable end sleeve Finely stranded without cable end sleeve Solid Stranded Ribbon cable (number x width x thickness) AWG conductors, solid or stranded 	mm ² 2.5 ... 35 mm ² 4 ... 50 mm ² 2.5 ... 16 mm ² 4 ... 70 mm 6 x 9 x 0.8 AWG 10 ... 2/0	16 ... 70 16 ... 70 — 16 ... 70 min. 3 x 9 x 0.8, max. 6 x 15.5 x 0.8 6 ... 2/0	70 ... 240 70 ... 240 — 95 ... 300 min. 6 x 9 x 0.8 max. 20 x 24 x 0.5 3/0 ... 600 kcmil	— — — — — —
 NSB00479					
Rear terminal connected	<ul style="list-style-type: none"> Finely stranded with cable end sleeve Finely stranded without cable end sleeve Solid Stranded Ribbon cable (number x width x thickness) AWG conductors, solid or stranded 	mm ² 2.5 ... 50 mm ² 10 ... 50 mm ² 2.5 ... 16 mm ² 10 ... 70 mm 6 x 9 x 0.8 AWG 10 ... 2/0	16 ... 70 16 ... 70 — 16 ... 70 min. 3 x 9 x 0.8, max. 6 x 15.5 x 0.8 6 ... 2/0	120 ... 185 120 ... 185 — 120 ... 240 min. 6 x 9 x 0.8 max. 20 x 24 x 0.5 250 ... 500 kcmil	— — — — — —
 NSB00480					
Both terminals connected	<ul style="list-style-type: none"> Finely stranded with cable end sleeve Finely stranded without cable end sleeve Solid Stranded Ribbon cable (number x width x thickness) AWG conductors, solid or stranded Connecting screws - Tightening torque 	mm ² 2 x (2.5 ... 35) mm ² 2 x (4 ... 35) mm ² 2 x (2.5 ... 16) mm ² 2 x (4 ... 50) mm 2 x (6 x 9 x 0.8) AWG 2 x (10 ... 1/0) Nm 4 ... 6 lbf.in 36 ... 53	max. 1 x 50, 1 x 70 max. 1 x 50, 1 x 70 — max. 2 x 70 max. 2 x (6 x 15.5 x 0.8) max. 2 x 1/0 M6 (hexagon socket, A/ F4)	min. 2 x 50; max. 2 x 185 min. 2 x 50; max. 2 x 185 — min. 2 x 70; max. 2 x 240 max. 2 x (20 x 24 x 0.5) min. 2 x 2/0; max. 2 x 500 kcmil M12 (hexagon socket, A/F5)	— — — — — — — — — —
 NSB00481					
Screw-type terminals	Main conductor:				
With box terminal			3RT19 56-4G	—	—
Front or rear terminal connected	<ul style="list-style-type: none"> Finely stranded with cable end sleeve Finely stranded without cable end sleeve Stranded Ribbon cable (number x width x thickness) AWG conductors, solid or stranded 	mm ² — mm ² — mm ² — mm — AWG —	16 ... 120 16 ... 120 16 ... 120 min. 3 x 9 x 0.8 max. 6 x 15.5 x 0.8 6 ... 250 kcmil	— — — — —	— — — — —
 NSB00479	 NSB00480				
Both terminals connected	<ul style="list-style-type: none"> Finely stranded with cable end sleeve Finely stranded without cable end sleeve Stranded Ribbon cable (number x width x thickness) AWG conductors, solid or stranded 	mm ² — mm ² — mm ² — mm — AWG —	max. 1 x 95, 1 x 120 max. 1 x 95, 1 x 120 max. 2 x 120 max. 2 x (10 x 15.5 x 0.8) max. 2 x 3/0	— — — — —	— — — — —
 NSB00481					
Screw-type terminals	Main conductor:				
	<u>Without box terminal / busbar connections</u>				
	<ul style="list-style-type: none"> Finely stranded with cable lug Stranded with cable lug AWG conductors, solid or stranded Connecting bar (max. width) Connecting screws - Tightening torque 	mm ² — mm ² — AWG — mm — Nm — lbf.in —	16 ... 95 ¹⁾ 25 ... 120 ¹⁾ 4 ... 250 kcmil 17 M8 x 25 (A/F13) 10 ... 14 89 ... 124	50 ... 240 ²⁾ 70 ... 240 ²⁾ 2/0 ... 500 kcmil 25 M10 x 30 (A/F17) 14 ... 24 124 ... 210	50 ... 240 ²⁾ 70 ... 240 ²⁾ 2/0 ... 500 kcmil 60 M12 x 40 20 ... 35 177 ... 310

1) When connecting cable lugs according to DIN 46235 from a conductor cross-section of 95 mm², the 3RT19 56-4EA1 terminal cover is required to ensure phase clearance.2) When connecting cable lugs according to DIN 46234 from a conductor cross-section of 240 mm² as well as DIN 46235 from a conductor cross-section of 185 mm², the 3RT19 66-4EA1 terminal cover is required to ensure phase clearance.

11.3 Technical data



Soft starters	Type	3RW44 ..	
Conductor cross-sections			
Auxiliary conductor (1 or 2 conductors can be connected):			
Screw-type terminals			
• Solid	mm ²	2 x (0.5 ... 2.5)	
• Finely stranded with cable end sleeve	mm ²	2 x (0.5 ... 1.5)	
• AWG conductors	AWG	2 x (20 ... 14)	
- solid or stranded	AWG	2 x (20 ... 16)	
- Finely stranded with cable end sleeve			
• Connecting screws	Nm	0.8 ... 1.2	
- Tightening torque	lbf.in	7 ... 10.3	
Spring-type terminals			
• Solid	mm ²	2 x (0.25 ... 1.5)	
• Finely stranded with cable end sleeve	mm ²	2 x (0.25 ... 1.5)	
• AWG conductors, solid or stranded	AWG	2 x (24 ... 16)	

11.3.5 Electromagnetic compatibility

	Standard	Parameter
Electromagnetic Compatibility according to EN 60947-4-2		
<i>EMC interference immunity</i>		
Electrostatic discharge (ESD)	EN 61000-4-2	±4 kV contact discharge, ±8 kV air discharge
Electromagnetic HF fields	EN 61000-4-3	Frequency range: 80 ... 1000 MHz with 80 % at 1 kHz Severity 3, 10 V/m
Conducted HF interference	EN 61000-4-6	Frequency range: 150 kHz ... 80 MHz with 80 % at 1 kHz Interference 10 V
HF voltages and HF currents on conductors		
• Burst	EN 61000-4-4	±2 kV/5 kHz
• Surge	EN 61000-4-5	±1 kV line to line ±2 kV line to ground
<i>EMC emission</i>		
EMC radio interference field strength	EN 55011	Limit value of Class A at 30 ... 1000 MHz
Radio interference voltage	EN 55011	Limit value of Class A at 0.15 ... 30 MHz
<i>Is a radio interference suppression filter required?</i>		
Radio interference suppression A (industrial application)		No

Types of coordination

The DIN EN 60947-4-1 (VDE 0660 Part 102) or IEC 60947-4-1 standard distinguishes between two types of coordination, referred to as coordination type "1" and coordination type "2". The short circuit that needs to be dealt with is cleared reliably and safely with both types of coordination; the only differences are in the extent of the damage sustained by the device following a short circuit.

Type of coordination 1	Type of coordination 2
	
The fuseless load feeder may be non-operational after a short circuit has been cleared. Damage to the contactor or to the overload release is permissible. For 3RA1 load feeders, the circuit breaker itself always achieves type 2 coordination.	There must be no damage to the overload release or to any other components after a short circuit has been cleared. The 3RA1 fuseless load feeder can resume operation without needing to be renewed. At most, welding of the contactor contacts is permissible if they can be disconnected easily without any significant deformation.

11.3.6 Feeder component layout (standard circuit)

Fuse assignment

The type of coordination according to which the motor feeder with soft starter is mounted depends on the application-specific requirements. Normally, fuseless mounting (combination of motor starter protector and soft starter) is sufficient. If type of coordination 2 is to be fulfilled, semiconductor fuses must be fitted in the motor feeder.

Standard circuit fuseless design

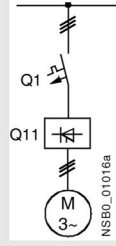

Soft starters Q11 Type	Nominal current A	Circuit breaker ¹⁾	
		400 V +10 % Q1 Type	Rated current A
Utilization class 1: 3RW44 22 and 3RW44 23: I _q = 42 kA; 3WR44 24 ... 3RW44 27: I _q = 32 kA; 3RW44 34 and 3RW44 35: I _q = 16 kA; 3RW44 36 ... 3RW44 66: I _q = 65 kA			
3RW4422	29	3RV2021-4EA10	32
3RW4423	36	3RV2021-4FA10	40
3RW4424	47	3RV2031-4WA10	52
3RW4425	57	3RV2031-4JA10	65
3RW4426	77	3RV2031-4RA10	80
3RW4427	93	3RV1042-4MA10	100
3RW4434	113	3VL1716-2DD36	160
3RW4435	134	3VL1716-2DD36	160
3RW4436	162	3VL3725-2DC36	250
3RW4443	203	3VL4731-3DC36	315
3RW4444	250	3VL4731-3DC36	315
3RW4445	313	3VL4740-3DC36	400
3RW4446	356	3VL4740-3DC36	400
3RW4447	432	3VL5750-3DC36	500
3RW4453	551	3VL6780-3SB36	800
3RW4454	615	3VL6780-3SB36	800
3RW4455	693	3VL6780-3SB36	800
3RW4456	780	3VL7710-3SB36	1000
3RW4457	880	3VL7710-3SB36	1000
3RW4458	970	3VL7712-3SB36	1250
3RW4465	1 076	3VL7712-3SB36	1 250
3RW4466	1 214	3VL7712-3SB36	1 250

1) The rated motor current must be taken into consideration during device selection.

Standard circuit fused design (line protection only)

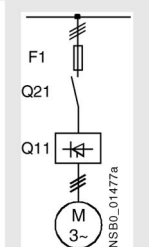

Soft starters Q11 Type	Nominal current A	Line fuse, maximum 690 V +5 %			Line contactor up to 400 V (option) Q21 Type	Braking contactor ¹⁾²⁾	
		E1 Type	Rated current A	Size		Q91 Type	Q92 Type
Utilization class 1 ³⁾ : $I_q = 65 \text{ kA}$							
3RW4422	29	3NA3820-6	50	00	3RT2027	3RT2526	--
3RW4423	36	3NA3822-6	63	00	3RT2028	3RT2526	--
3RW4424	47	3NA3824-6	80	00	3RT2036	3RT2535	--
3RW4425	57	3NA3830-6	100	00	3RT2037	3RT2535	--
3RW4426	77	3NA3132-6	125	1	3RT2038	3RT2024	3RT2035
3RW4427	93	3NA3136-6	160	1	3RT2046	3RT2025	3RT2036
3RW4434	113	3NA3244-6	250	2	3RT1054	3RT2027	3RT2037
3RW4435	134	3NA3244-6	250	2	3RT1055	3RT2036	3RT2038
3RW4436	162	3NA3365-6	500	3	3RT1056	3RT2037	3RT2038
3RW4443	203	2 x 3NA3354-6	2 x 355	3	3RT1064	3RT2037	3RT1054
3RW4444	250	2 x 3NA3354-6	2 x 355	3	3RT1065	3RT2037	3RT1055
3RW4445	313	2 x 3NA3365-6	2 x 500	3	3RT1075	3RT1054	3RT1056
3RW4446	356	2 x 3NA3365-6	2 x 500	3	3RT1075	3RT1054	3RT1056
3RW4447	432	2 x 3NA3365-6	2 x 500	3	3RT1076	3RT1055	3RT1064
3RW4453	551	2 x 3NA3365-6	2 x 500	3	3TF68	3RT1064	3RT1066
3RW4454	615	2 x 3NA3365-6	2 x 500	3	3TF68	3RT1064	3RT1075
3RW4455	693	2 x 3NA3365-6	2 x 500	3	3TF69	3RT1065	3RT1075
3RW4456	780	2 x 3NA3365-6	2 x 500	3	3TF69	3RT1065	3RT1075
3RW4457	880	2 x 3NA3365-6	2 x 500	3		3RT1075	3RT1076
3RW4458	970	3 x 3NA3365-6	3 x 500	3		3RT1075	3RT1076
3RW4465	1 076	3 x 3NA3365-6	3 x 500	3		3RT1075	3TF68
3RW4466	1 214	3 x 3NA3365-6	3 x 500	3		3RT1076	3TF68

- 1) If the "Combined braking" stopping function is selected, no braking contactor is required.
If the "DC braking" function is selected, a braking contactor must be additionally used (for type, see table).
The "DC braking" function is recommended for applications with larger centrifugal masses ($J_{load} > J_{motor}$).
- 2) Additional K4 auxiliary relay:
LZX:RT4A4T30 (3RW44 soft starter with 230 V AC rated control supply voltage),
LZX:RT4A4S15 (3RW44 soft starter with 115 V AC rated control supply voltage).
- 3) "Utilization class 1" refers to the soft starter in combination with the protective device listed (circuit breaker/fuse), not to other components in the branch.

11.3 Technical data

Standard circuit fused design with SITOR 3NE1 all-range fuse (semiconductor and line protection)

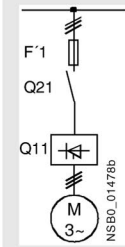

For suitable fuse bases, see LV1 catalog at "SETRON Switching and Protection Devices for Power Distribution" -> "Switch Disconnectors" and ET B1 Catalog at "BETA Protecting" -> "SITOR Semiconductor Fuses" and/or at www.siemens.com/sitor > SITOR Semiconductor Fuses

Soft starters Q11 Type	Nominal current A	All-range fuse				Line contactor up to 400 V (option) Q21 Type	Braking contactor ¹⁾²⁾	
		E1 Type	Rated current A	Voltage V	Size		Q91 Type	Q92 Type
Utilization class 2 ³⁾ : $I_q = 65 \text{ kA}$								
3RW4422	29	3NE1020-2	80	690 +5 %	00	3RT2027	3RT2526	--
3RW4423	36	3NE1020-2	80	690 +5 %	00	3RT2028	3RT2526	--
3RW4424	47	3NE1021-2	100	690 +5 %	00	3RT2036	3RT2535	--
3RW4425	57	3NE1022-2	125	690 +5 %	00	3RT2037	3RT2535	--
3RW4426	77	3NE1022-2	125	690 +5 %	00	3RT2038	3RT2024	3RT2035
3RW4427	93	3NE1224-2	160	690 +5 %	1	3RT2046	3RT2025	3RT2036
3RW4434	113	3NE1225-2	200	690 +5 %	1	3RT1054	3RT2027	3RT2037
3RW4435	134	3NE1227-2	250	690 +5 %	1	3RT1055	3RT2036	3RT2038
3RW4436	162	3NE1227-2	250	690 +5 %	1	3RT1056	3RT2037	3RT2038
3RW4443	203	3NE1230-2	315	600 +10 %	1	3RT1064	3RT2037	3RT1054
3RW4444	250	3NE1331-2	350	460 +10 %	2	3RT1065	3RT2037	3RT1055
3RW4445	313	3NE1333-2	450	690 +5 %	2	3RT1075	3RT1054	3RT1056
3RW4446	356	3NE1334-2	500	690 +5 %	2	3RT1075	3RT1054	3RT1056
3RW4447	432	3NE1435-2	560	690 +5 %	3	3RT1076	3RT1055	3RT1064
3RW4453	551	2 x 3NE1334-2	500	690 +10 %	2	3TF68	3RT1064	3RT1066
3RW4454	615	2 x 3NE1334-2	500	690 +10 %	2	3TF68	3RT1064	3RT1075
3RW4455	693	2 x 3NE1334-2	500	690 +10 %	2	3TF69	3RT1065	3RT1075
3RW4456	780	2 x 3NE1435-2	560	690 +10 %	3	3TF69	3RT1065	3RT1075
3RW4457	880	2 x 3NE1435-2	560	690 +10 %	3		3RT1075	3RT1076
3RW4458	970	2 x 3NE1435-2	560	690 +10 %	3		3RT1075	3RT1076
3RW4465	1 076	3 x 3NE1334-2	500	690 +10 %	2		3RT1075	3TF68
3RW4466	1 214	3 x 3NE1435-2	560	690 +10 %	3		3RT1076	3TF68

- 1) If the "Combined braking" stopping function is selected, no braking contactor is required.
If the "DC braking" function is selected, a braking contactor must be additionally used (for type, see table).
The "DC braking" function is recommended for applications with larger centrifugal masses ($J_{load} > J_{motor}$).
- 2) Additional K4 auxiliary relay:
LZX:RT4A4T30
(3RW44 soft starter with 230 V AC rated control supply voltage),
LZX:RT4A4S15
(3RW44 soft starter with 115 V AC rated control supply voltage).
- 3) "Utilization class 2" refers to the soft starter in combination with the protective device listed (circuit breaker/fuse), not to other components in the branch.

Standard circuit fused design with SITOR 3NE or 3NC semiconductor fuse
(semiconductor protection using fuse, line and overload protection using circuit breaker)

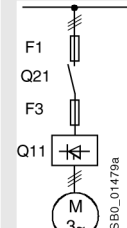
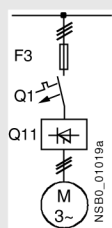

For suitable fuse bases, see LV1 catalog at "SENTRON Switching and Protection Devices for Power Distribution" -> "Switch Disconnectors" and ET B1 Catalog at "BETA Protecting" -> "SITOR Semiconductor Fuses" and/or at www.siemens.com/sitor > SITOR Semiconductor Fuses

Soft starters ToC 2 Q11 Type	Nominal current A	Semiconductor fuse minimum			Semiconductor fuse (cylinder)		
		690 V +10 % E3 Type	Rated current A	Size	E3 Type	Rated current A	Size
Utilization class 2¹⁾; I_q = 65 kA							
3RW44 22	29	3NE4 120	80	0	3NC2 280	80	22 x 58
3RW44 23	36	3NE4 121	100	0	3NC2 200	100	22 x 58
3RW44 24	47	3NE4 121	100	0	3NC2 200	100	22 x 58
3RW44 25	57	3NE4 122	125	0			
3RW44 26	77	3NE4 124	160	0			
3RW44 27	93	3NE3 224	160	1			
3RW44 34	113	3NE3 225	200	1			
3RW44 35	134	3NE3 225	200	1			
3RW44 36	162	3NE3 227	250	1			
3RW44 43	203	3NE3 230-0B	315	1			
3RW44 44	250	3NE3 230-0B	315	1			
3RW44 45	313	3NE3 233	450	1			
3RW44 46	356	3NE3 333	450	2			
3RW44 47	432	3NE3 335	560	2			
3RW44 53	551	2 x 3NE3 335	560	2			
3RW44 54	615	2 x 3NE3 335	560	2			
3RW44 55	693	2 x 3NE3 335	560	2			
3RW44 56	780	2 x 3NE3 336	630	2			
3RW44 57	880	2 x 3NE3 336	630	2			
3RW44 58	970	2 x 3NE3 336	630	2			
3RW44 65	1076	2 x 3NE3 340-8	900	2			
3RW44 66	1214	2 x 3NE3 340-8	900	2			

1) "Utilization class 2" refers to the soft starter in combination with the protective device listed (circuit breaker/fuse), not to other components in the branch.

11.3 Technical data

Soft starters T _{AC} 2	Nominal current	Line contactor up to 400 V (option)	Braking contactor ¹⁾²⁾		Circuit breaker		Line fuse, maximum			
			Q11 Type	Q21 Type	Q91 Type	Q92 Type	400 V +10 %	Rated current	690 V +5 %	Rated current
Utilization class 2 ³⁾ : I _n = 65 kA										
3RW4422	29	3RT2027	3RT2526	--	3RV2021-4EA10	32	3NA3820-6	50	00	
3RW4423	36	3RT2028	3RT2526	--	3RV2021-4FA10	40	3NA3822-6	63	00	
3RW4424	47	3RT2036	3RT2535	--	3RV2031-4WA10	52	3NA3824-6	80	00	
3RW4425	57	3RT2037	3RT2535	--	3RV2031-4JA10	65	3NA3830-6	100	00	
3RW4426	77	3RT2038	3RT2024	3RT2035	3RV2031-4RA10	80	3NA3132-6	125	1	
3RW4427	93	3RT2046	3RT2025	3RT2036	3RV1042-4MA10	100	3NA3136-6	160	1	
3RW4434	113	3RT1054	3RT2027	3RT2037	3VL1716	160	3NA3244-6	250	2	
3RW4435	134	3RT1055	3RT2036	3RT2038	3VL1716	160	3NA3244-6	250	2	
3RW4436	162	3RT1056	3RT2037	3RT2038	3VL3725	250	3NA3365-6	500	3	
3RW4443	203	3RT1064	3RT2037	3RT1054	3VL4731	315	2 x 3NA3354-6	2 x 355	3	
3RW4444	250	3RT1065	3RT2037	3RT1055	3VL4731	315	2 x 3NA3354-6	2 x 355	3	
3RW4445	313	3RT1075	3RT1054	3RT1056	3VL4740	400	2 x 3NA3365-6	2 x 500	3	
3RW4446	356	3RT1075	3RT1054	3RT1056	3VL4740	400	2 x 3NA3365-6	2 x 500	3	
3RW4447	432	3RT1076	3RT1055	3RT1064	3VL5750	500	2 x 3NA3365-6	2 x 500	3	
3RW4453	551	3TF68	3RT1064	3RT1066	3VL6780	800	2 x 3NA3365-6	2 x 500	3	
3RW4454	615	3TF68	3RT1064	3RT1075	3VL6780	800	2 x 3NA3365-6	2 x 500	3	
3RW4455	693	3TF69	3RT1065	3RT1075	3VL6780	800	2 x 3NA3365-6	2 x 500	3	
3RW4456	780	3TF69	3RT1065	3RT1075	3VL7710	1000	2 x 3NA3365-6	2 x 500	3	
3RW4457	880		3RT1075	3RT1076	3VL7710	1000	2 x 3NA3365-6	2 x 500	3	
3RW4458	970		3RT1075	3RT1076	3VL7712	1250	3 x 3NA3365-6	3 x 500	3	
3RW4465	1076		3RT1075	3TF68	3VL7712	1250	3 x 3NA3365-6	3 x 500	3	
3RW4466	1214		3RT1076	3TF68	3VL7712	1250	3 x 3NA3365-6	3 x 500	3	

- 1) If the "Combined braking" stopping function is selected, no braking contactor is required.
If the "DC braking" function is selected, a braking contactor must be additionally used (for type, see table).
The "DC braking" function is recommended for applications with larger centrifugal masses ($J_{load} > J_{motor}$).
- 2) Additional K4 auxiliary relay:
LZX:RT4A4T30 (3RW44 soft starter with 230 V AC rated control supply voltage),
LZX:RT4A4S15 (3RW44 soft starter with 115 V AC rated control supply voltage).
- 3) "Utilization class 2" refers to the soft starter in combination with the protective device listed (circuit breaker/fuse), not to other components in the branch.

11.3.7 Feeder component layout (inside-delta circuit)

Inside delta circuit fused design with SITOR 3NE or 3NC fuses (semiconductor protection using fuse, line and overload protection using circuit breaker)

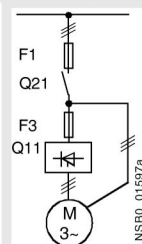
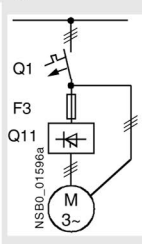

For suitable fuse bases, see LV1 catalog at "SENTRON Switching and Protection Devices for Power Distribution" -> "Switch Disconnectors" and ET B1 Catalog at "BETA Protecting" -> "SITOR Semiconductor Fuses" and/or at www.siemens.com/sitor > SITOR Semiconductor Fuses

Soft starters ToC 2	Nominal current A	Semiconductor fuse minimum			Semiconductor fuse (cylinder)		
		690 V +10 % E3 Type	Rated current A	Size	E3 Type	Rated current A	Size
Q11 Type							
Utilization class 2 ¹⁾							
3RW44 22	50	3NE4 120	80	0	3NC2 280	80	22 x 58
3RW44 23	62	3NE4 121	100	0	3NC2 200	100	22 x 58
3RW44 24	81	3NE4 121	100	0	3NC2 200	100	22 x 58
3RW44 25	99	3NE4 122	125	0			
3RW44 26	133	3NE4 124	160	0			
3RW44 27	161	3NE3 224	160	1			
3RW44 34	196	3NE3 225	200	1			
3RW44 35	232	3NE3 225	200	1			
3RW44 36	281	3NE3 227	250	1			
3RW44 43	352	3NE3 230-0B	315	1			
3RW44 44	433	3NE3 230-0B	315	1			
3RW44 45	542	3NE3 233	450	1			
3RW44 46	617	3NE3 333	450	2			
3RW44 47	748	3NE3 335	560	2			
3RW44 53	954	2 x 3NE3 335	560	2			
3RW44 54	1065	2 x 3NE3 335	560	2			
3RW44 55	1200	2 x 3NE3 335	560	2			
3RW44 56	1351	2 x 3NE3 336	630	2			
3RW44 57	1524	2 x 3NE3 336	630	2			
3RW44 58	1680	2 x 3NE3 336	630	2			
3RW44 65	1864	2 x 3NE3 340-8	900	2			
3RW44 66	2103	2 x 3NE3 340-8	900	2			

Note



If the F3 semiconductor fuse is not used, the type of coordination "2" is reduced to type of coordination "1" for soft starters in combination with the stipulated protective device.





11.3 Technical data

Soft starters Q11 Type	Nominal current A	Line contactor up to 400 V (option) Q21 Type	Circuit breaker 400 V +10 %		Line fuse, maximum 690 V +5 %		
			Rated current A	Q1 Type	Rated current A	E1 Type	Size
Utilization class 2¹⁾							
3RW4422	50	3RT2036-1AP04	3RV1042-4KA10	75	3NA3824-6	80	00
3RW4423	62	3RT2037-1AP04	3RV1042-4LA10	90	3NA3830-6	100	00
3RW4424	81	3RT2038-1AP04	3RV1042-4MA10	100	3NA3132-6	125	1
3RW4425	99	3RT1054-1AP36	3VL2716	160	3NA3136-6	160	1
3RW4426	133	3RT1055-6AP36	3VL2716	160	3NA3240-6	200	2
3RW4427	161	3RT1056-6AP36	3VL3720	200	3NA3244-6	250	2
3RW4434	196	3RT1064-6AP36	3VL3725	250	3NA3360-6	400	3
3RW4435	232	3RT1065-6AP36	3VL4731	315	3NA3360-6	400	3
3RW4436	281	3RT1066-6AP36	3VL4740	400	2 x 3NA3360-6	2 x 400	3
3RW4443	352	3RT1075-6AP36	3VL4740	400	2 x 3NA3365-6	2 x 500	3
3RW4444	433	3RT1076-6AP36	3VL5750	500	2 x 3NA3365-6	2 x 500	3
3RW4445	542	3TF6844-0CM7	3VL5763	630	3 x 3NA3365-6	3 x 500	3
3RW4446	617	3TF6844-0CM7	3VL6780	800	3 x 3NA3365-6	3 x 500	3
3RW4447	748	3TF69	3VL6780	800	3 x 3NA3365-6	3 x 500	3
3RW4453	954		3VL7710	1000	3 x 3NA3365-6	3 x 500	3
3RW4454	1065		3VL7712	1250	3 x 3NA3365-6	3 x 500	3
3RW4455	1200		3VL8716	1600	3 x 3NA3365-6	3 x 500	3
3RW4456	1351		3VL8716	1600	3 x 3NA3372	3 x 630	3
3RW4457	1524		3VL8716	1600	3 x 3NA3372	3 x 630	3
3RW4458	1680		3WL1220	2000	2 x 3NA3480	2 x 1000	4
3RW4465	1864		3WL1225	2500	2 x 3NA3482	2 x 1250	4
3RW4466	2103		3WL1225	2500	2 x 3NA3482	2 x 1250	4

1) "Utilization class 2" refers to the soft starter in combination with the protective device listed (circuit breaker/fuse), not to other components in the branch.

11.3.8 Accessories

	Version	DT	Article No.
Soft Starter ES 2007 Basic 3ZS1313-4CC10-0YA5 Floating			
 3ZS1313-4CC10-0YA5	Floating License for one user Engineering software in limited-function version for diagnostics purposes, software and documentation on CD, 3 languages (German/English/French), communication through system interface		
	<ul style="list-style-type: none"> License key on USB stick, Class A, including CD 	B	3ZS1313-4CC10-0YA5
	<ul style="list-style-type: none"> License key download, Class A, without CD 		3ZS1313-4CE10-0YB5
Soft Starter ES 2007 Standard			
 3ZS1313-5CC10-0YA5	Floating License for one user Engineering software, software and documentation on CD, 3 languages (German/English/French), communication through system interface		
	<ul style="list-style-type: none"> License key on USB stick, Class A, including CD 	B	3ZS1313-5CC10-0YA5
	<ul style="list-style-type: none"> License key download, Class A, without CD 		3ZS1313-5CE10-0YB5
	Upgrade for Soft Starter ES 2006 Floating license for one user, engineering software, software and documentation on CD, license key on USB stick, Class A, 3 languages (German/English/French), communication through the system interface	B	3ZS1313-5CC10-0YE5
	Powerpack for Soft Starter ES 2007 Basic Floating license for one user, engineering software, license key on USB stick, Class A, 3 languages (German/English/French), communication through the system interface	B	3ZS1313-5CC10-0YD5
	Software Update Service For 1 year with automatic extension, assuming the current software version is in use, engineering software, software and documentation on CD, communication through the system interface		3ZS1313-5CC10-0YL5
Optional accessories			
 3UF7941-0AA00-0	USB PC cable For connecting to the USB interface of a PC/PG, for communication with Soft Starter ES through the system interface		3UF7941-0AA00-0
	Optional communication module for SIRIUS 3RW44		
	<ul style="list-style-type: none"> PROFIBUS 		3RW4900-0KC00
<ul style="list-style-type: none"> PROFINET 		3RW4900-0NC00	

	Version	DT	Article No.	
Communication modules				
 <p>3RW4900-0KC00</p>	<p>PROFIBUS communication module</p> <p>For 3RW44 soft starter integration in the PROFIBUS network with DPV1 slave functionality. With firmware version E04 and higher (or date of manufacture May 1, 2009 and later) of the module, DPV1 operation of the soft starter on a Y-link is also possible (only DPV0 operation possible with < E04).</p>		3RW4900-0KC00	
	 <p>3RW4900-0NC00</p>	<p>PROFINET communication module</p> <p>For 3RW44 soft starter integration in the PROFINET network, suitable for devices with firmware version E12 or higher</p>		3RW4900-0NC00
External display and operator module				
 <p>3RW4900-0AC00</p>	<p>For indicating and operating the functions provided by the soft starter using an externally mounted display and operator module in IP54 degree of protection (e.g. in the control cabinet door)</p>			
	<p>Connecting cable</p> <p>From the device interface (serial) of the 3RW44 soft starter to the external display and operator module</p>			
	<p>Length 0.5 m, flat</p>		3UF7932-0AA00-0	
	<p>Length 0.5 m, round</p>		3UF7932-0BA00-0	
	<p>Length 1.0 m, round</p>		3UF7937-0BA00-0	
<p>Length 2.5 m, round</p>		3UF7933-0BA00-0		
Box terminal block for soft starters				
 <p>3RT19</p>	<p>Box terminal block</p> <p>(2 units required per device)</p>			
	3RW442.	Included in the scope of supply		
	3RW443.	<ul style="list-style-type: none"> Max. 70 mm² 		3RT1955-4G
		<ul style="list-style-type: none"> Up to 120 mm² 		3RT1956-4G
		<p>Auxiliary conductor connection for box terminals</p>	B	3TX7500-0A
3RW444.	<ul style="list-style-type: none"> Max. 240 mm² (with auxiliary conductor connection) 		3RT1966-4G	

	Version	DT	Article No.
Covers for soft starters			
	Terminal covers for box terminals Additional touch protection to be fitted at the box terminals (2 units required per device)		
	3RW442. and 3RW443.		3RT1956-4EA2
	3RW444.		3RT1966-4EA2
 3RT19.6-4EA1	Terminal covers for cable lugs and busbar connections		
	3RW442. and 3RW443.	For complying with the voltage clearances and as touch protection (2 units required per contactor)	3RT1956-4EA1
	3RW444.	Also fits on mounted box terminals	3RT1966-4EA1
SIRIUS 3RW44 Soft Starter Manual			
	The SIRIUS 3RW44 Soft Starter Manual (https://support.industry.siemens.com/cs/ww/en/view/21772518) is available at the Industry Online Support portal as a free PDF download.		

The SIRIUS 3RW442/443/444/445/446 soft starter operating instructions (<https://support.industry.siemens.com/cs/ww/en/view/21189750>) (article number 3ZX1012-0RW44-0AA0) are included in the scope of supply of the soft starter, or are available (like the manual) as a PDF download at the Industry Online Support Portal.

11.3.9 Spare parts

For soft starters	Version	DT	Article No.
Type			
Fans			
 3RW49	Fans		
	3RW442. and 3RW443.	115 V AC 230 V AC	▶ 3RW4936-8VX30 ▶ 3RW4936-8VX40
	3RW444.	115 V AC 230 V AC	▶ 3RW4947-8VX30 ▶ 3RW4947-8VX40
	3RW445. and 3RW446. ¹⁾	115 V AC 230 V AC	▶ 3RW4957-8VX30 ▶ 3RW4957-8VX40
	3RW446. ²⁾	115 V AC 230 V AC	▶ 3RW4966-8VX30 ▶ 3RW4966-8VX40

1) 3RW446. mounting on output side.
2) For mounting on front side.

Note
3RW4422 and 3RW4423

The 3RW4422 and 3RW4423 soft starters do not need fans. These devices are adequately designed for natural convection.

11.4 Tripping characteristics

11.4.1 Motor protection tripping characteristics: 3RW44 with symmetry

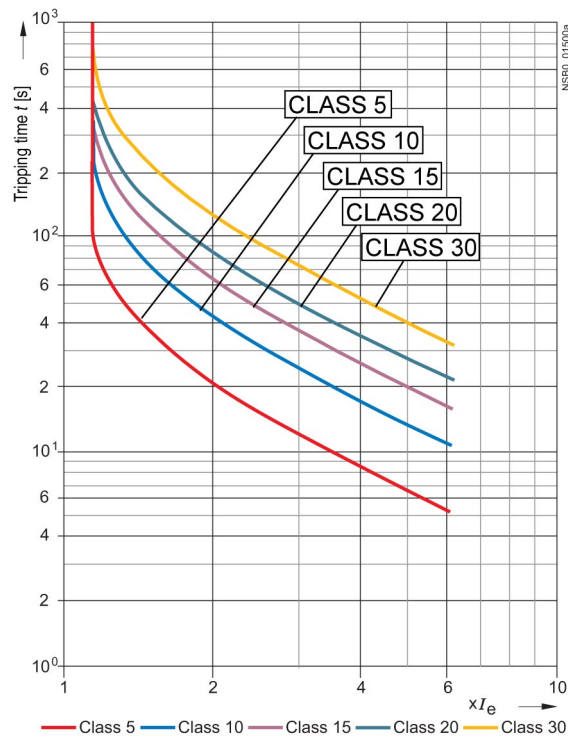

11.4.2 Motor protection tripping characteristics: 3RW44 with asymmetry

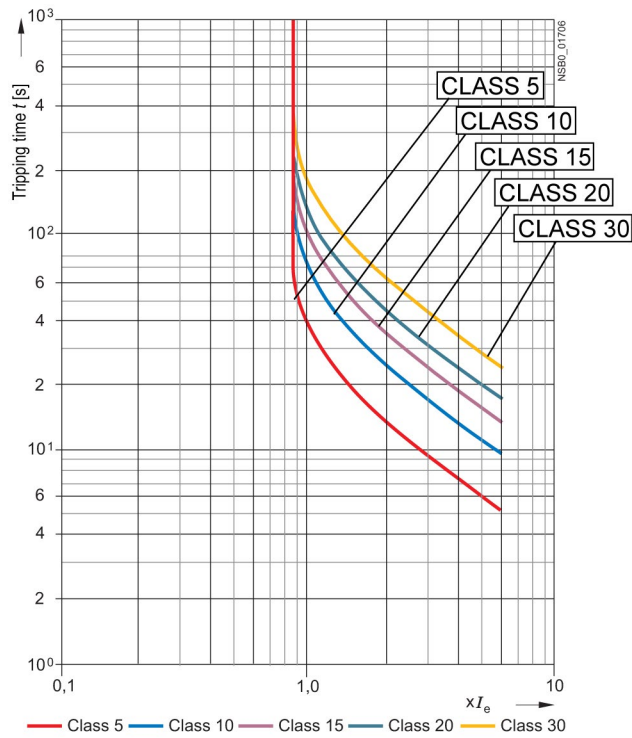

11.5 Dimension drawings

11.5.1 Dimension drawings

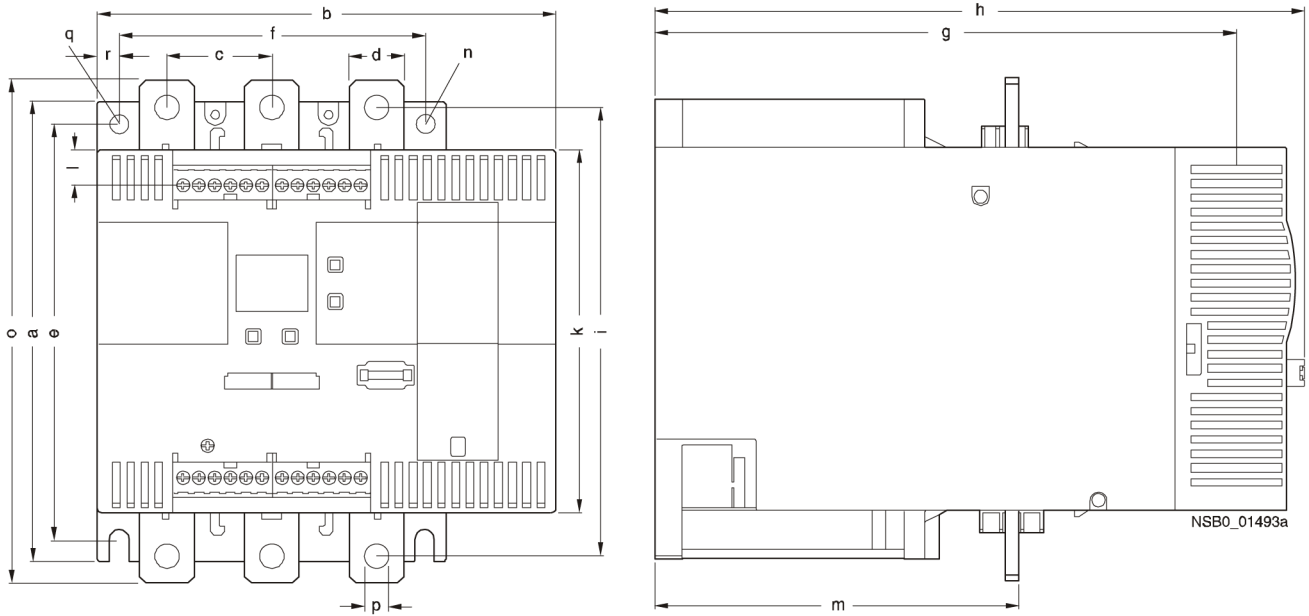

Figure 11-1 3RW44 2, 3RW44 3, 3RW44 4

	3RW44 2	3RW44 3	3RW44 4
a	180 mm (7.09 in)	180 mm (7.09 in)	210 mm (8.27 in)
b	170 mm (6.69 in)	170 mm (6.69 in)	210 mm (8.27 in)
c	37 mm (1.46 in)	37 mm (1.46 in)	48 mm (1.89 in)
d	11 mm (0.43 in)	17 mm (0.67 in)	25 mm (0.98 in)
e	167 mm (6.57 in)	167 mm (6.57 in)	190 mm (7.48 in)
f	100 mm (3.94 in)	100 mm (3.94 in)	140 mm (5.51 in)
g	240 mm (9.45 in)	240 mm (9.45 in)	269 mm (10.59 in)
h	270 mm (10.63 in)	270 mm (10.63 in)	298 mm (11.73 in)
i	174 mm (6.85 in)	174 mm (6.85 in)	205 mm (8.07 in)
k	148 mm (5.83 in)	148 mm (5.83 in)	166 mm (6.54 in)
l	7.5 mm (0.30 in)	7.5 mm (0.30 in)	16 mm (0.63 in)
m	153 mm (6.02 in)	153 mm (6.02 in)	166 mm (6.54 in)
n	7 mm (0.28 in)	7 mm (0.28 in)	9 mm (0.35 in)
o	184 mm (7.24 in)	198 mm (7.80 in)	230 mm (9.06 in)
p	6.6 mm (0.26 in)	9 mm (0.35 in)	11 mm (0.43 in)
q	M6 10 Nm (89 lbf.in)	M6 10 Nm (89 lbf.in)	M8 15 Nm (134 lbf.in)
r	10 mm (0.39 in)	10 mm (0.39 in)	10 mm (0.39 in)
Weight	6.5 kg	7.9 kg	11.5 kg

11.5 Dimension drawings

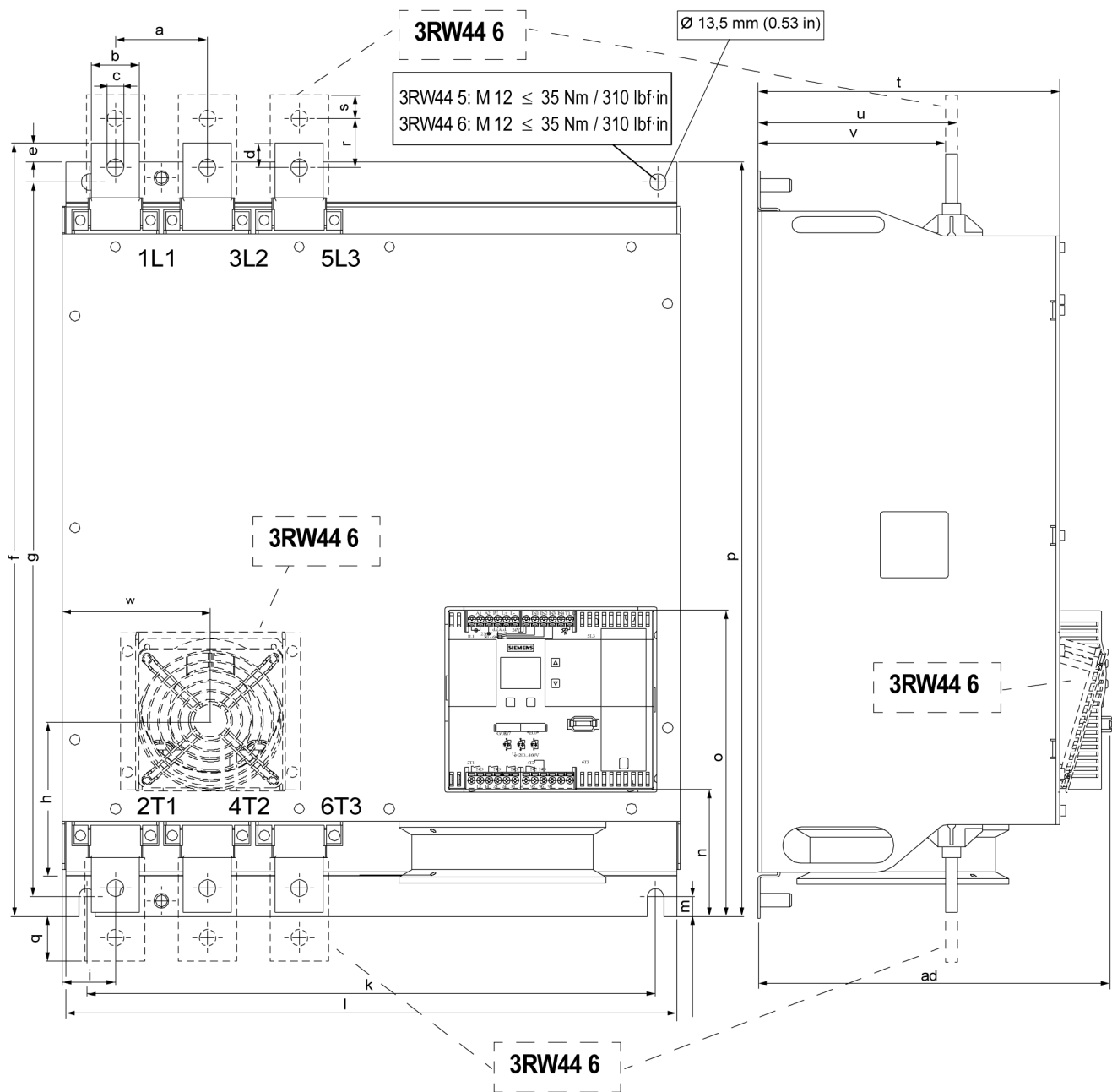

Figure 11-2 3RW44 5/3RW44 6

	3RW44 5	3RW44 6
a	76 mm (3 in)	85 mm (3.35 in)
b	40 mm (1.6 in)	50 mm (1.97 in)
c	14 mm (0.6 in)	14 mm (0.6 in)
d	20 mm (0.8 in)	-
e	15.5 mm (0.7 in)	-
f	638.5 mm (25.2 in)	667 mm (26.3 in)
g	590 mm (9.45 in)	660 mm (26 in)
h	-	160 mm (6.3 in)
i	44 mm (1.8 in)	37.5 mm (1.48 in)
k	470mm (18 in)	535 mm (21 in)
l	510 mm (20 in)	576 mm (22.7 in)
m	16.5 mm (0.7 in)	16.5 mm (0.7 in)
n	105 mm (4.1 in)	103 mm (4.06 in)
o	253 mm (10 in)	251 mm (9.88 in)
p	623 mm (24.6 in)	693 mm (27.3 in)
q	-	43.5 mm (1.71 in)
r	-	40 mm (1.6 in)
s	-	20 mm (0.78 in)
t	249 mm (9.8 in)	249 mm (9.8 in)
u	162 mm (6.4 in)	162 mm (6.4 in)
v	152 mm (5.9 in)	151.4 mm (5.96 in)
w	-	123 mm (4.84 in)
ad	290 mm	290 mm
Weight	50.0 kg	78.0 kg

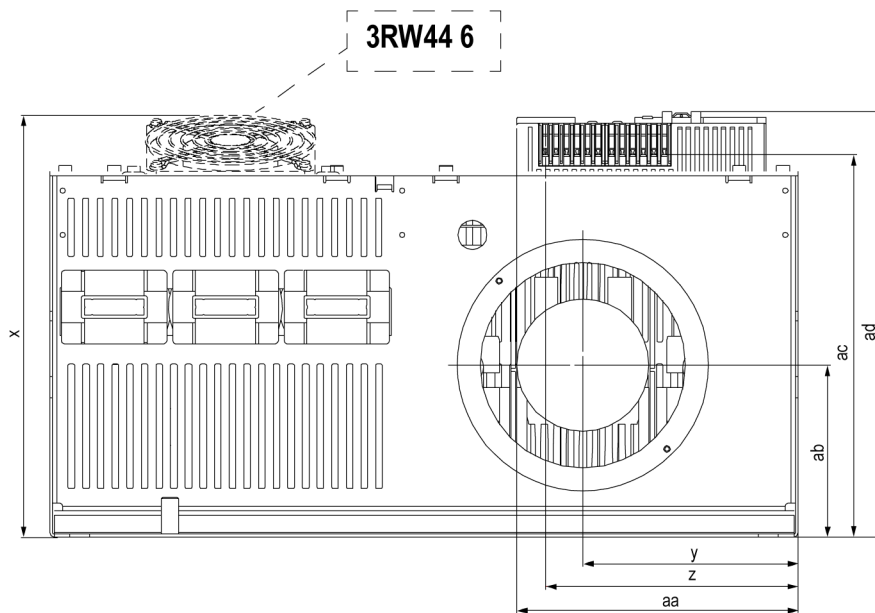
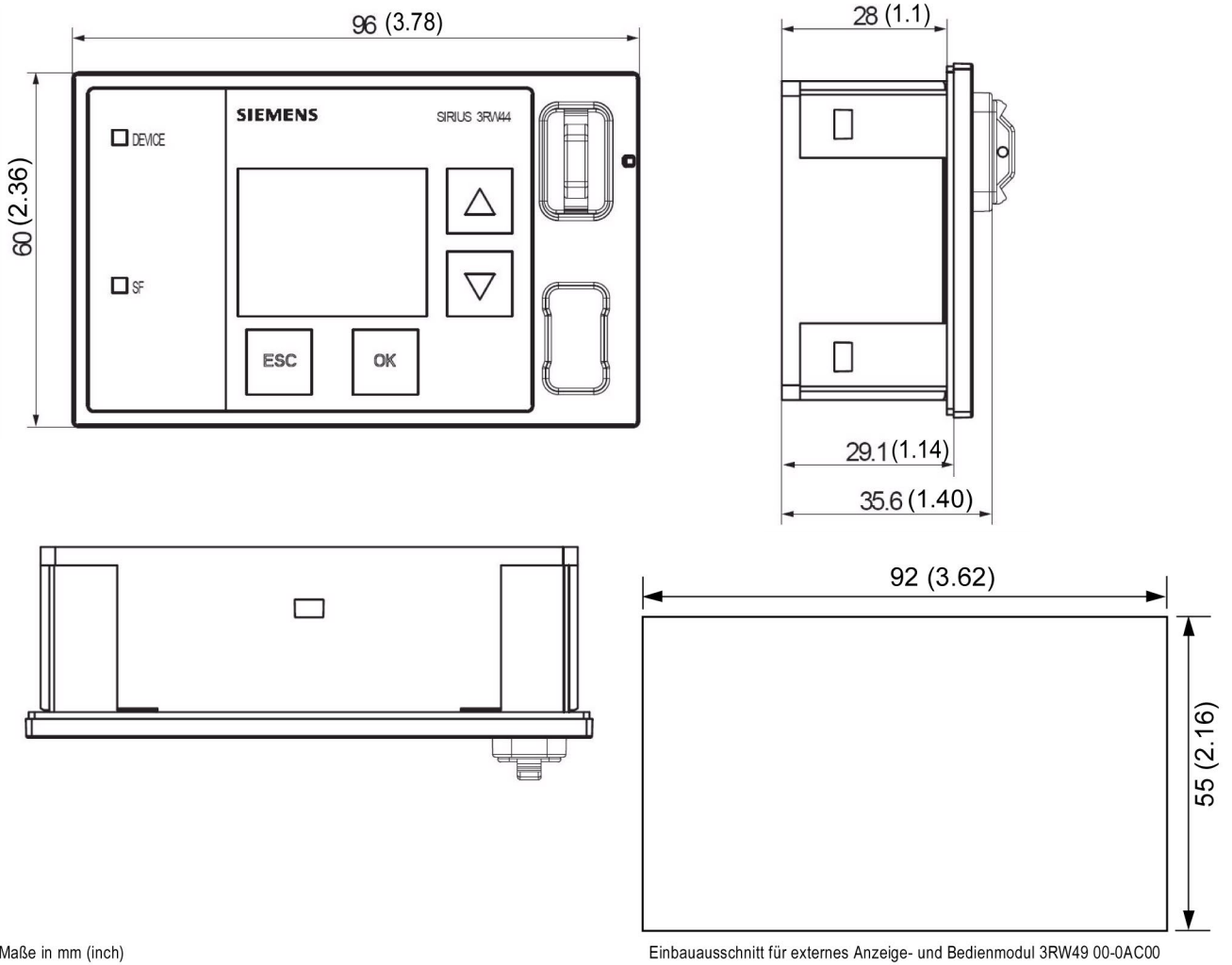

Figure 11-3 3RW44 6

	3RW44 5	3RW44 6
x	290 mm (11.4 in)	289.5 mm (11.4 in)
y	147 mm (5.7 in)	175 mm (6.9 in)
z	173 mm (6.9 in)	173 mm (6.8 in)
aa	195 mm (7.7 in)	-
ab	118 mm (4.6 in)	118 mm (4.65 in)
ac	261 mm (10.2 in)	261 mm (10.28 in)
ad	290 mm (11.5 in)	290 mm (11.42 in)



Maße in mm (inch)

Einbauausschnitt für externes Anzeige- und Bedienmodul 3RW49 00-0AC00

Figure 11-4 External display and operator module 3RW49 00-0AC00

Appendix

A

Configuration data

1. Motor data

Siemens motor?	
Rated power:	kW
Rated voltage:	V
Line frequency:	Hz
Rated current:	A
Starting current:	A
Rated speed:	rpm
Rated torque:	Nm
Breakdown torque:	Nm
Mass moment of inertia:	kg*m2

Speed/torque characteristic curve

(The speed increments of the value pairs do not have to be equal)

n _M 1/m													"n _{syn} "
M _M %													

Speed/current characteristic curve

(The speed increments of the value pairs do not have to be equal)

n _M 1/m													"n _{syn} "
I _M %													

2. Load data

Load type (e.g. pump, mill, etc.):	
Rated speed:	rpm
Rated torque or rated output	Nm or kW
Mass moment of inertia (load-specific)	kg*m ²
Mass moment of inertia (motor-specific)	kg*m ²

Speed/torque characteristic curve

(The speed increments of the value pairs do not have to be equal)

n _L 1/m													"n _{syn} "
M _L %													

3. Start conditions

Starting frequency		Starts
Switching cycles:	Ramp-up time	
	Operating time	
	Idle time	
	Coast-down time	
Ambient temperature		°C

	Yes	Value
Starting current limitation?	<input type="checkbox"/>
Acceleration torque limitation?	<input type="checkbox"/>
Maximum starting time?	<input type="checkbox"/>

4. Personal details

Last name, first name:.....

Company:

Department:

Street:

Zip code, town/city:

Country:

Phone:

Fax:

E-mail:

Index

A

Ambient temperature, 27
Application examples, 22
Applications, 19, 125, 130
Asymmetry, 144
Asymmetry limit value, 144

B

Breakaway pulse, 130
Breakaway time, 131
Breakaway voltage, 130
Byte arrangements, 198

C

Capacitor, 43
CLASS 10, 22, 145
CLASS 10A, 145
CLASS setting, 143, 145, 155
Coast-down time, 136, 139, 140, 140
Coasting down, 136
Coasting methods, 135
Combined braking, 139
Configuration, 21
Configuring with GSD, 173
Contact element, 34
Control voltage versions, 44
Current asymmetry limit value, 144
Current limiting, 133
Current limiting value, 132
Current limits, 143

D

Data sets, 198
DC braking, 138, 140
DC braking torque, 139, 140
Degree of protection, 32
Diagnostics, 149
Disconnecter, 34
Dynamic braking torque, 139

F

Factory settings, 28

G

Ground fault, 154
GSD file, 173

I

Idle time, 145, 145
Inchnig, 145
Installation altitude, 27
Internal run-up recognition, 127, 129
Intrinsic device protection, 147

L

Limiting torque, 128
Locked-rotor torque, 15, 126, 128, 130

M

Maximum pointer, 195
Maximum starting time, 126
Messages, 149
Motor heating, 134, 144
Motor overload protection, 143
Motor protection function, 143

O

ON time motor, 26
Overtemperature, 154

P

Parameter sets, 125
PC Interface, 21
Phase failure, 151
PLC, 34, 155, 155, 199, 199, 208
Prewarning limit, 144
Profibus, 51

PROFIBUS DP communication
module, 151, 152, 157, 160, 160, 164, 165, 166, 168,
171, 175, 176, 176
Protection against voltage failure, 146
PTC thermistors, 146
Pump stop, 136, 137

R

Ramp-up detection, 133, 134
Rated speed, 141
Reduced starting current, 15
Run-up recognition, 127, 129

S

Screw connections, 44
See display for details of the operating and monitoring
module, 21
See operating and monitoring module for details of the
display, 21
Selection criteria, 19
Semiconductor fuse, 41, 147
SITOR, 41, 147
SITOR fuses, 41
SITOR semiconductor fuse, 147
Size
 3RW44 2., 44
 3RW44 3., 45
 3RW44 4., 45
Slow speed factor, 141
Slow speed torque, 141
Software, 21, 51
Spring-loaded connections, 44
Starting current, 14
Starting time, 126, 129
Starting torque, 128
Starting voltage, 126
Startup, 18, 19
Startup class, 22
Stopping torque, 136
Supply voltage, 152
Switching frequency, 26

T

Temperature sensor, 146
Thermoclick sensors, 146
Three-phase asynchronous motors, 144
Torque control, 128
Tripping class, 143, 144

V

Very heavy starting, 25
Voltage ramp, 126, 128

W

Water hammer, 137